

16-S-32 FOR FENDL-3.1 FROM TENDL-2010 WITH NJOY2012.50+

Principal cross sections

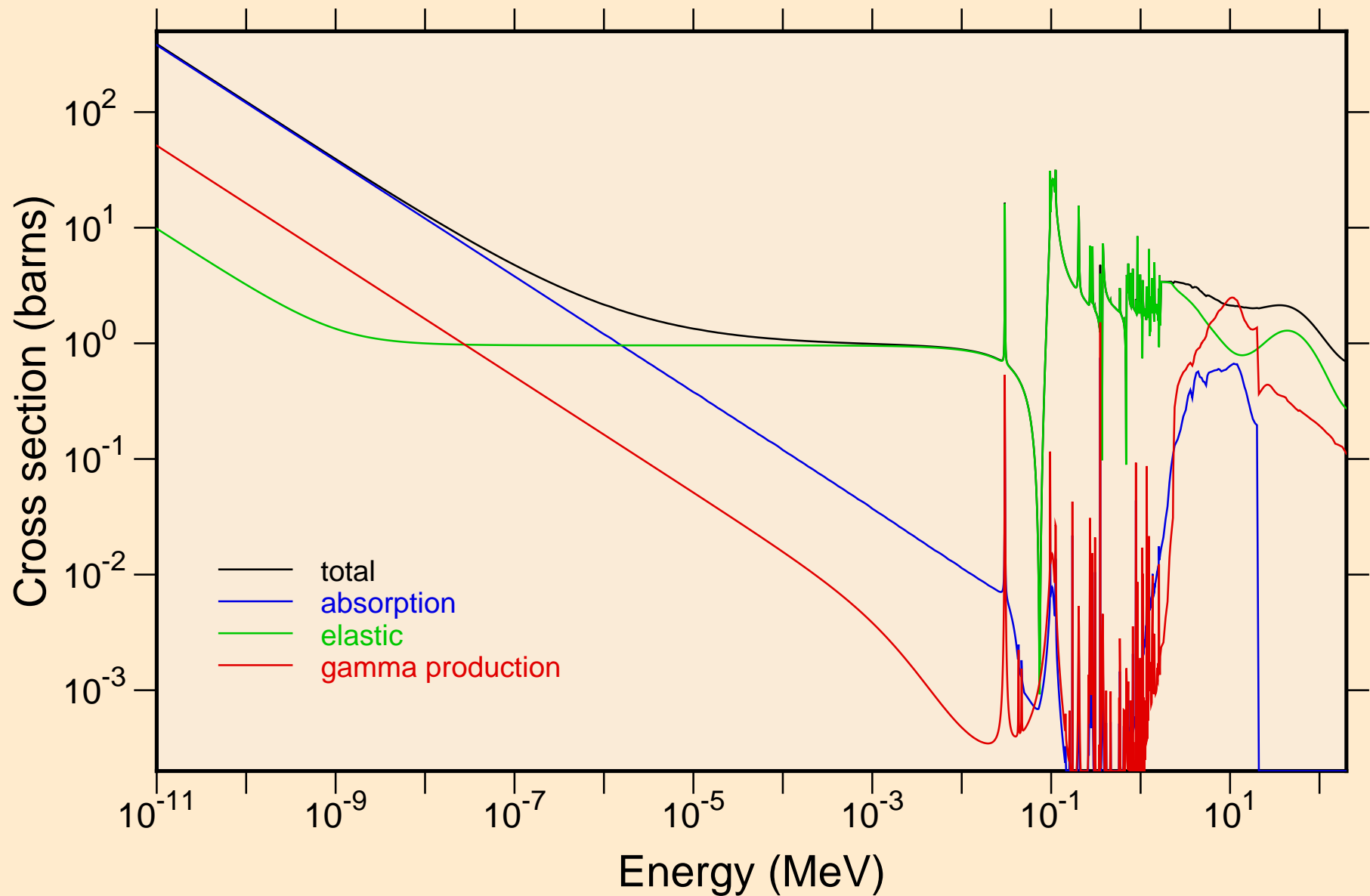

16-S-32 FOR FENDL-3.1 FROM TENDL-2010 WITH NJOY2012.50+
resonance total cross section

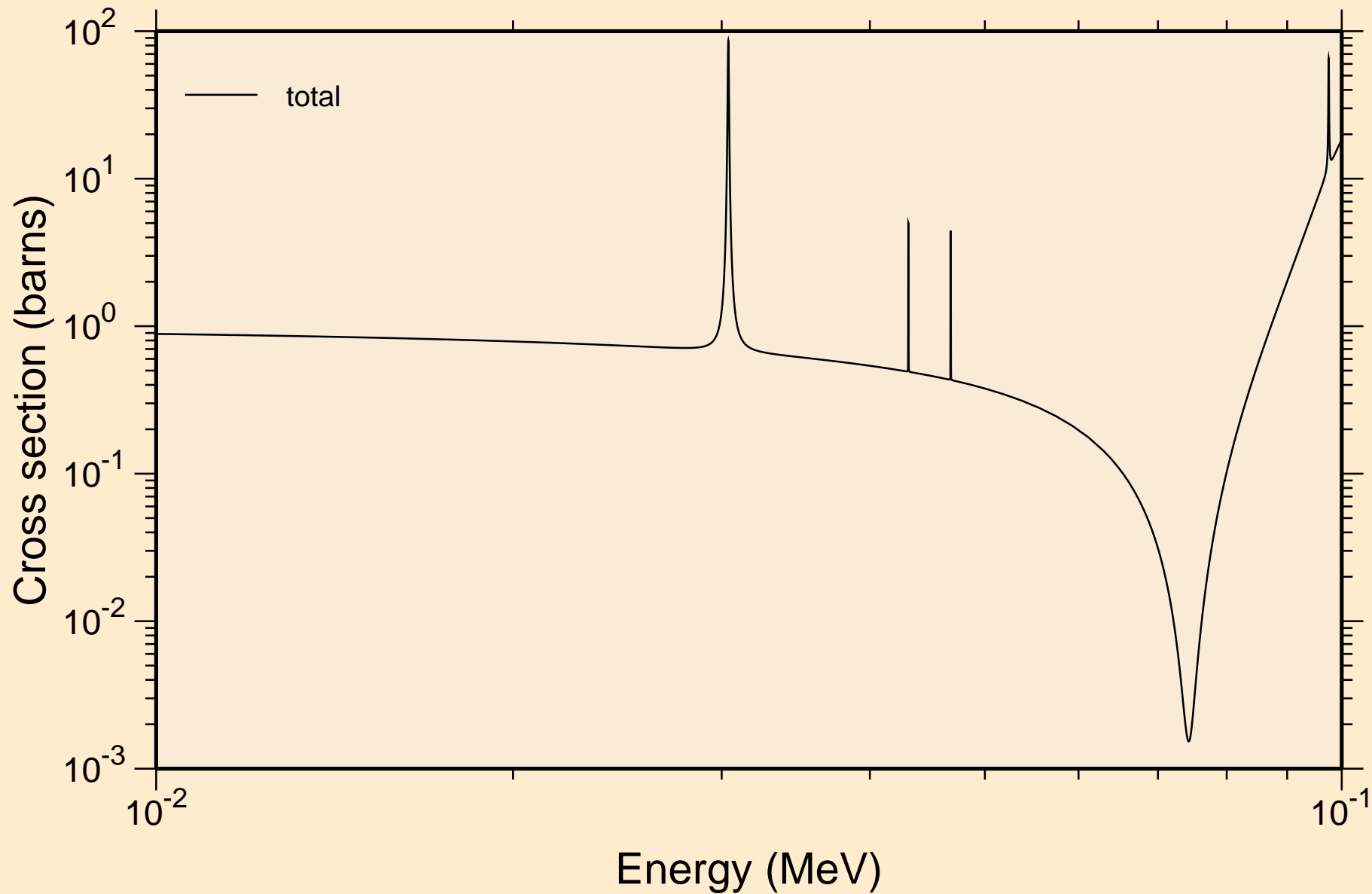

16-S-32 FOR FENDL-3.1 FROM TENDL-2010 WITH NJOY2012.50+
resonance total cross section

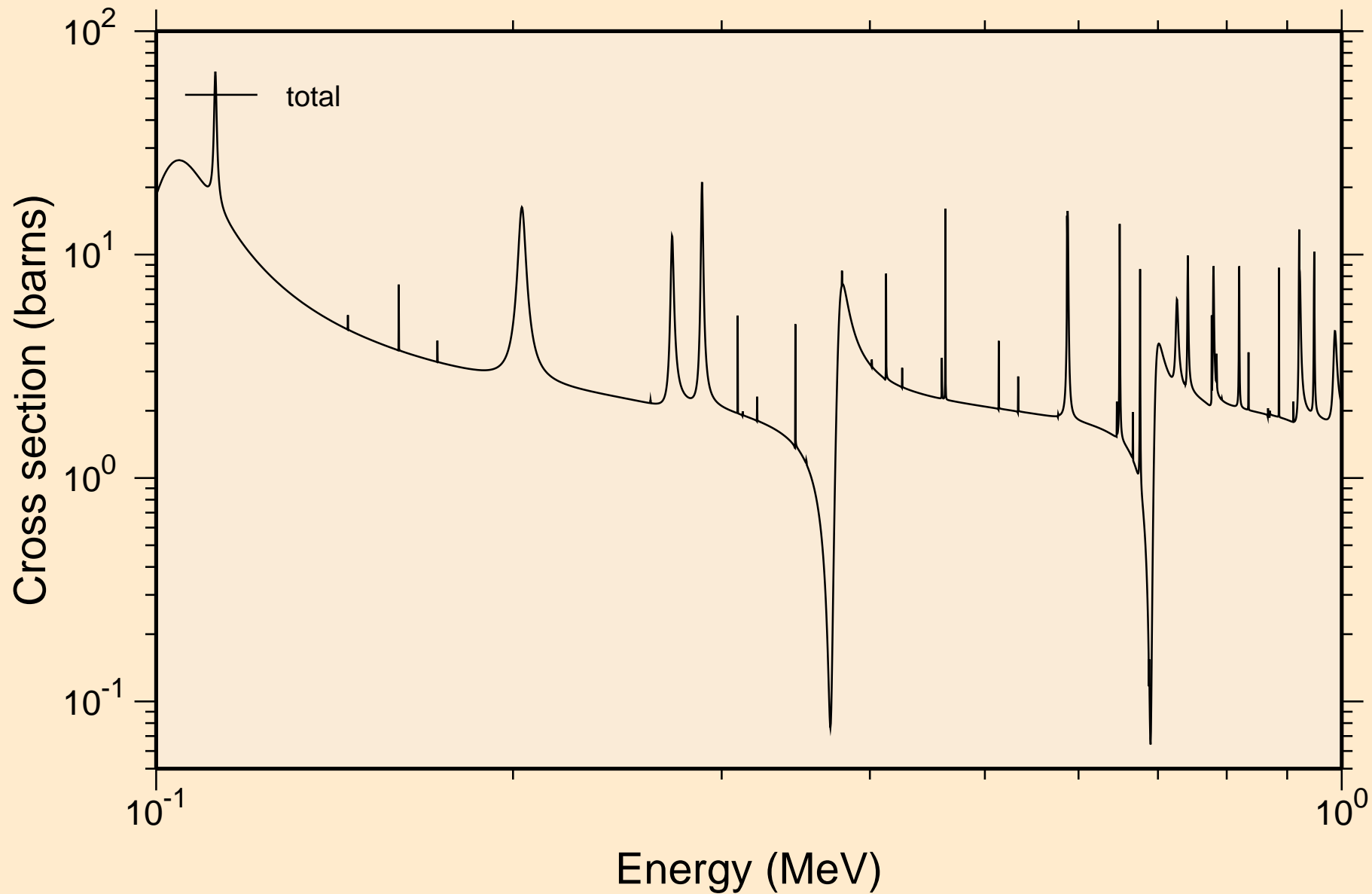

16-S-32 FOR FENDL-3.1 FROM TENDL-2010 WITH NJOY2012.50+
resonance total cross section

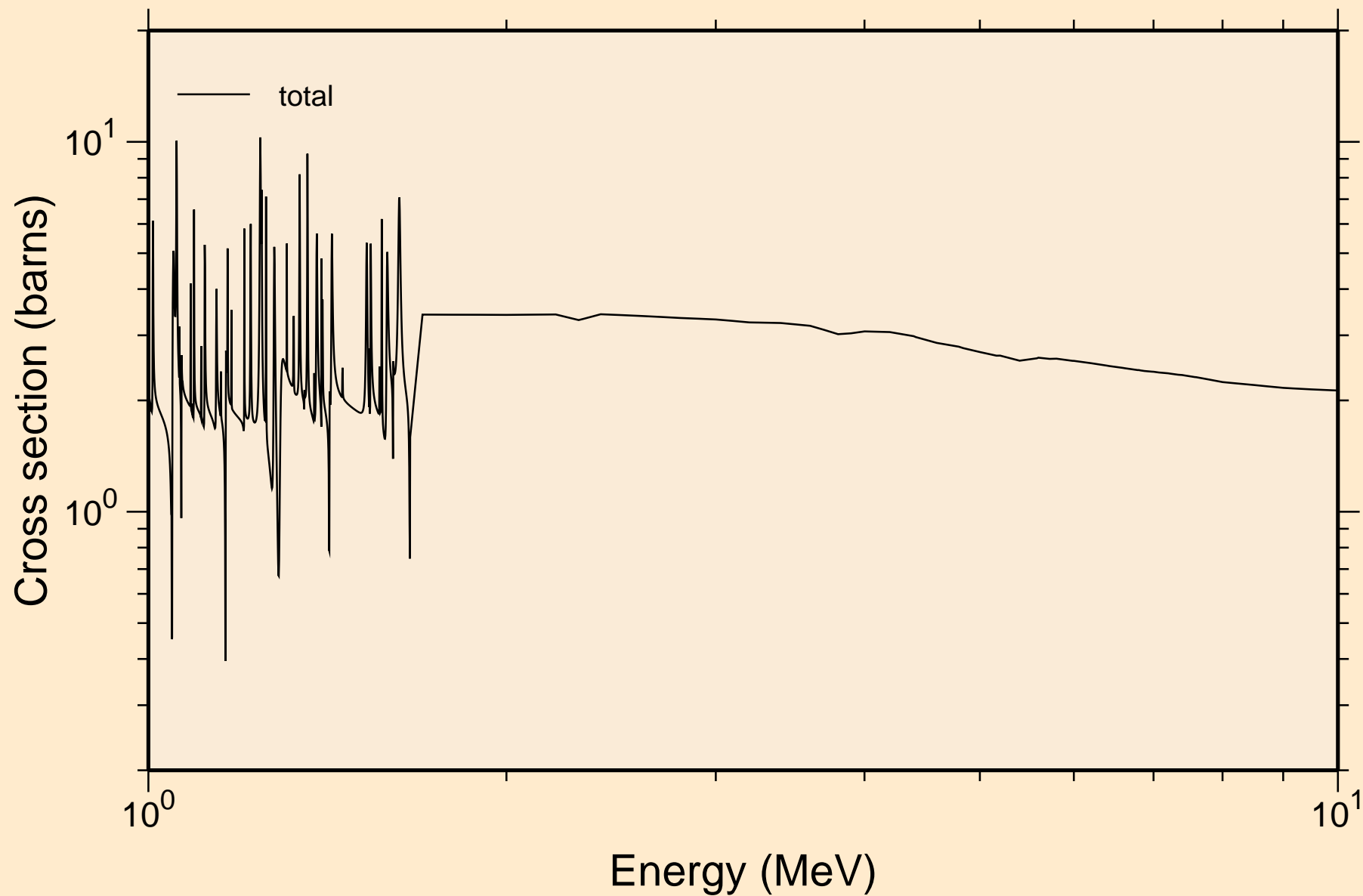

16-S-32 FOR FENDL-3.1 FROM TENDL-2010 WITH NJOY2012.50+
resonance absorption cross sections

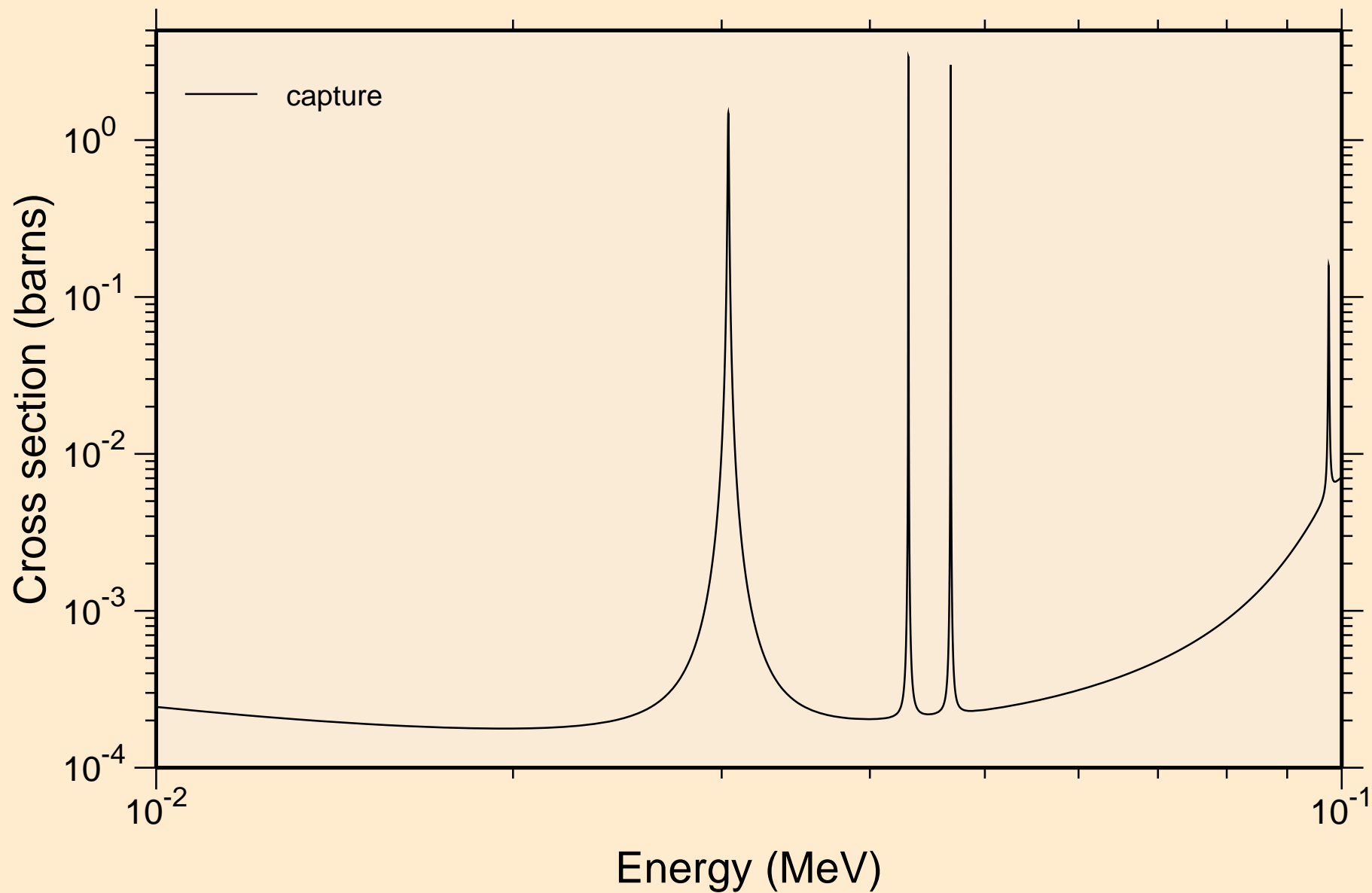

16-S-32 FOR FENDL-3.1 FROM TENDL-2010 WITH NJOY2012.50+
resonance absorption cross sections

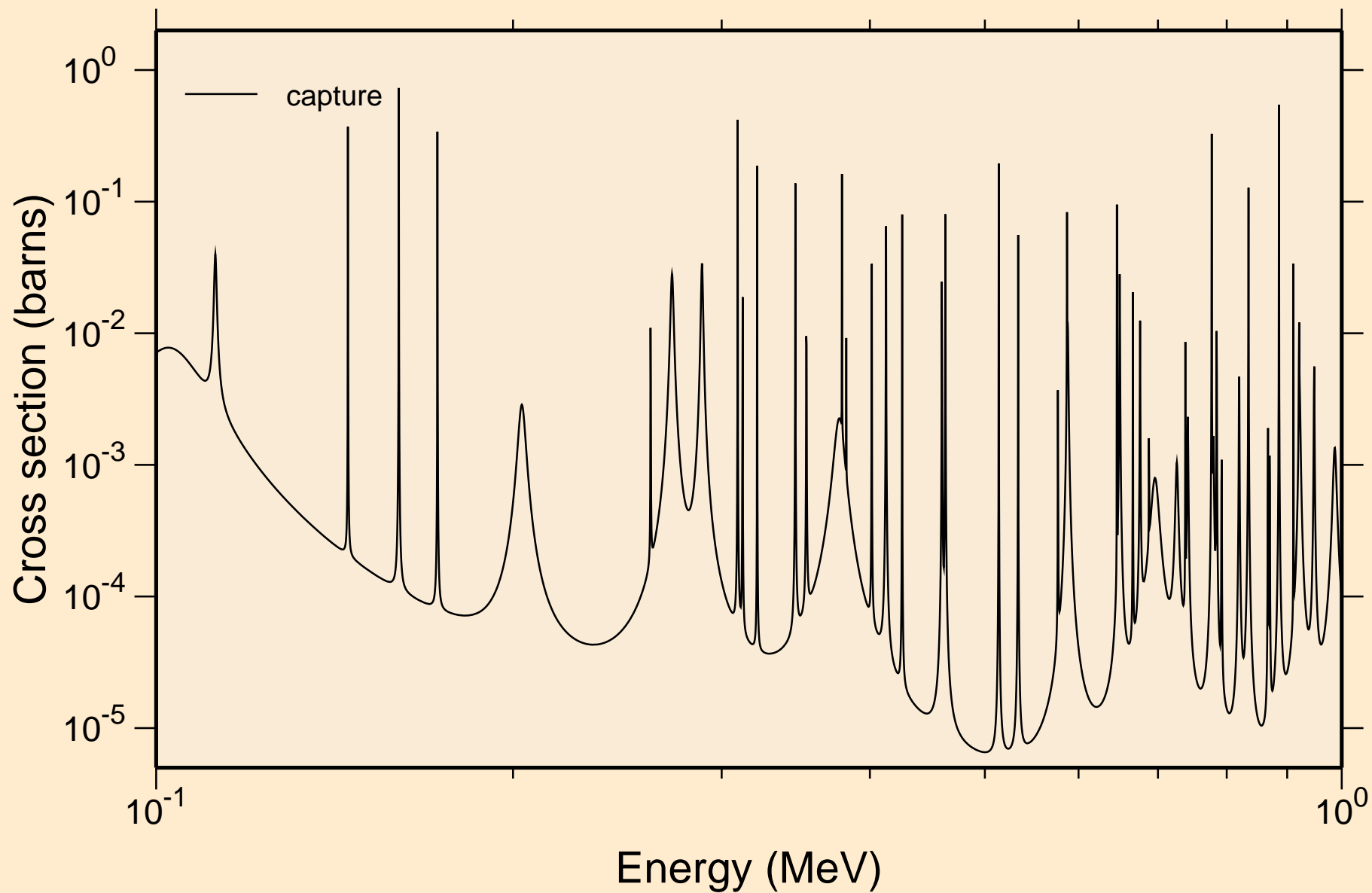

16-S-32 FOR FENDL-3.1 FROM TENDL-2010 WITH NJOY2012.50+
resonance absorption cross sections

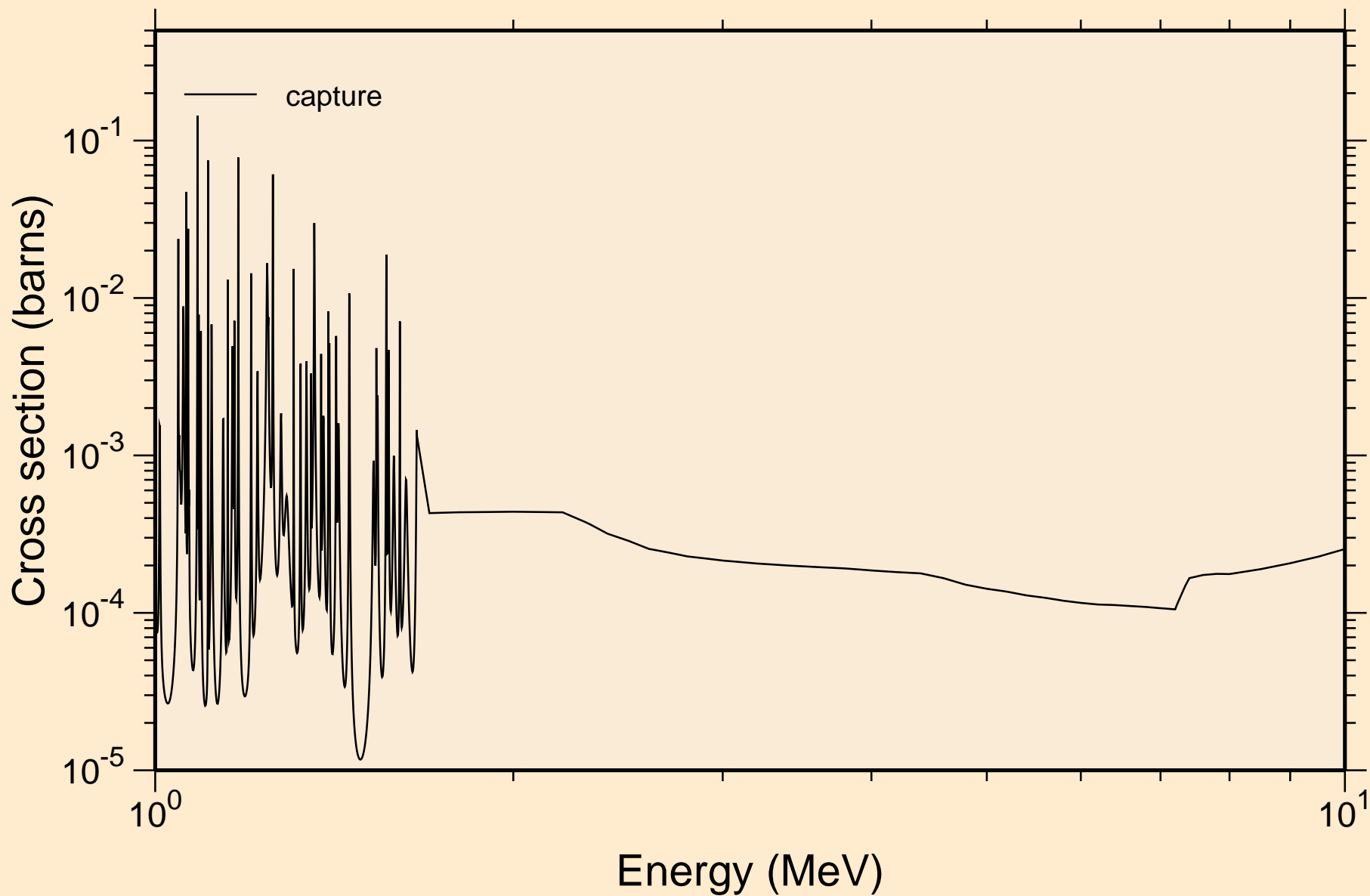

16-S-32 FOR FENDL-3.1 FROM TENDL-2010 WITH NJOY2012.50+ Heating

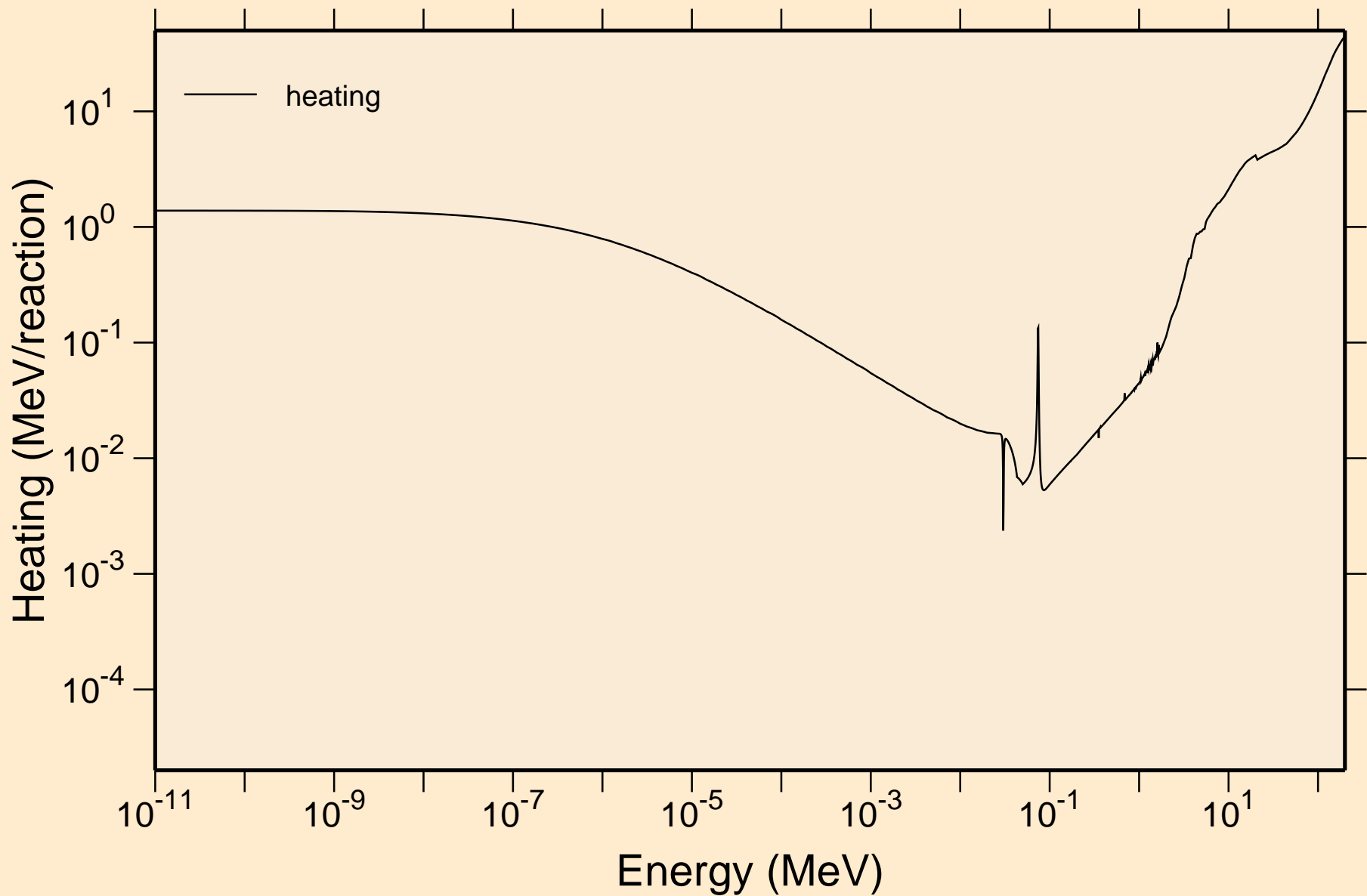

16-S-32 FOR FENDL-3.1 FROM TENDL-2010 WITH NJOY2012.50+ Damage

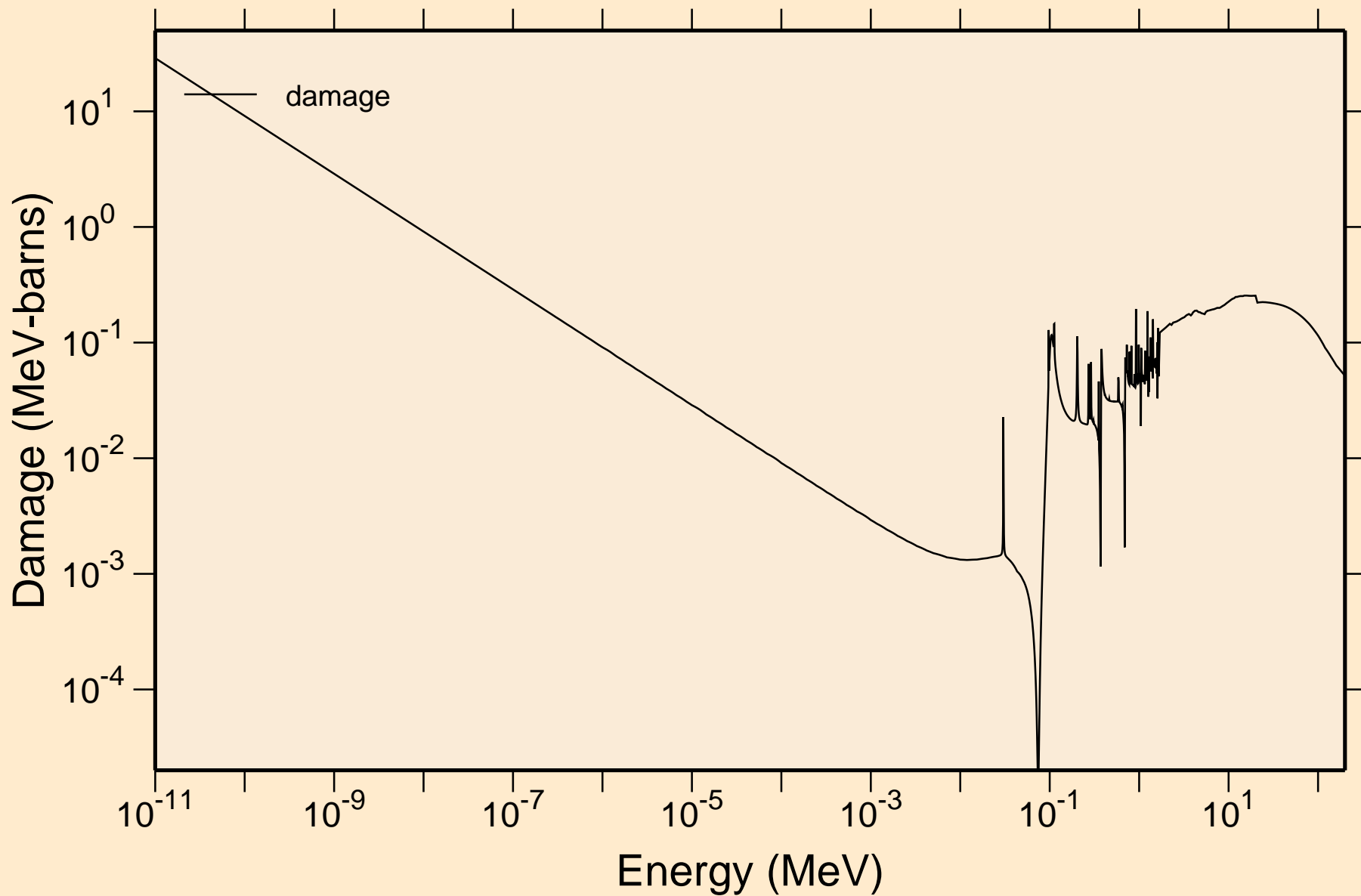

16-S-32 FOR FENDL-3.1 FROM TENDL-2010 WITH NJOY2012.50+

Non-threshold reactions

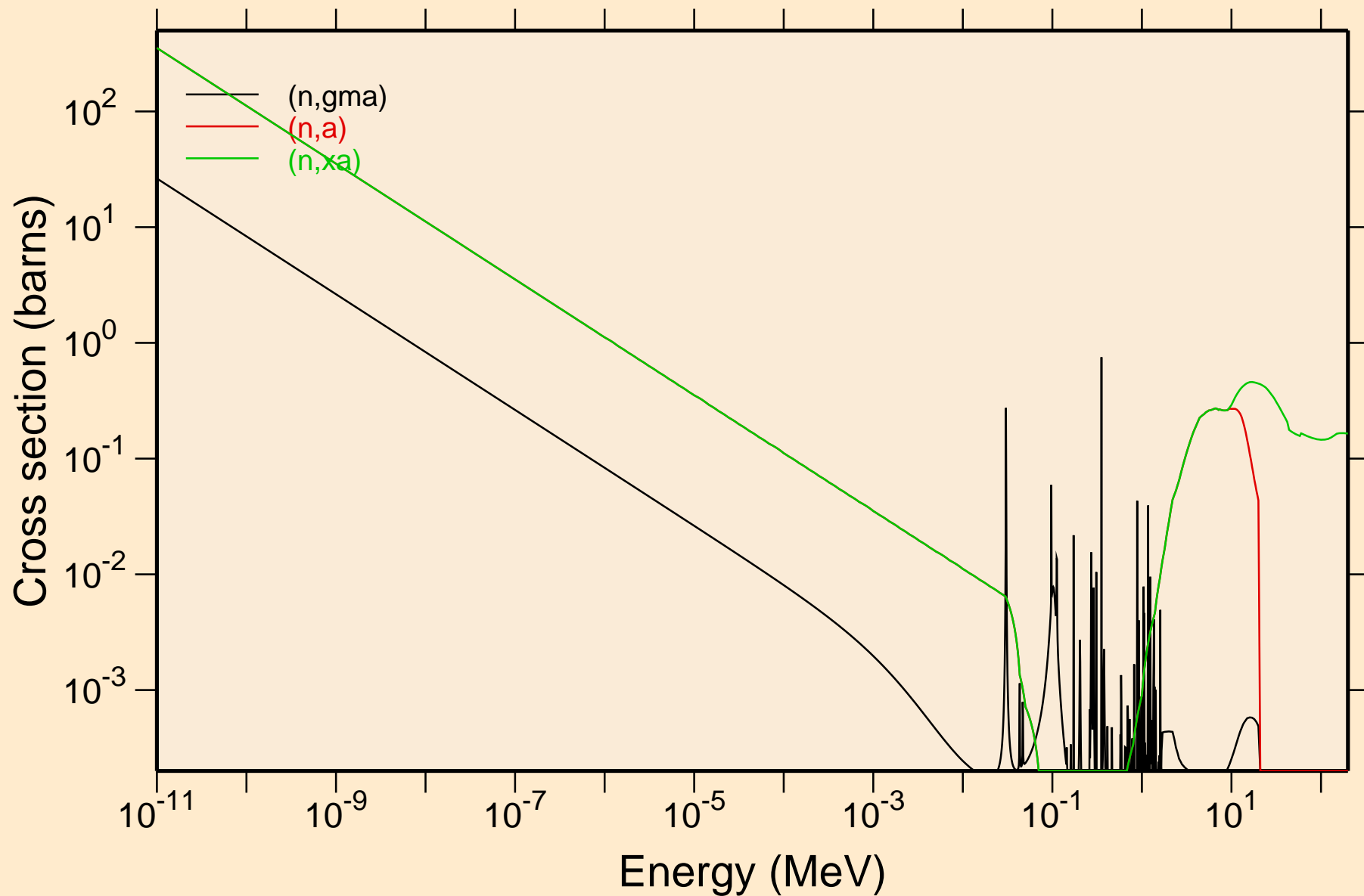

16-S-32 FOR FENDL-3.1 FROM TENDL-2010 WITH NJOY2012.50+

Principal cross sections

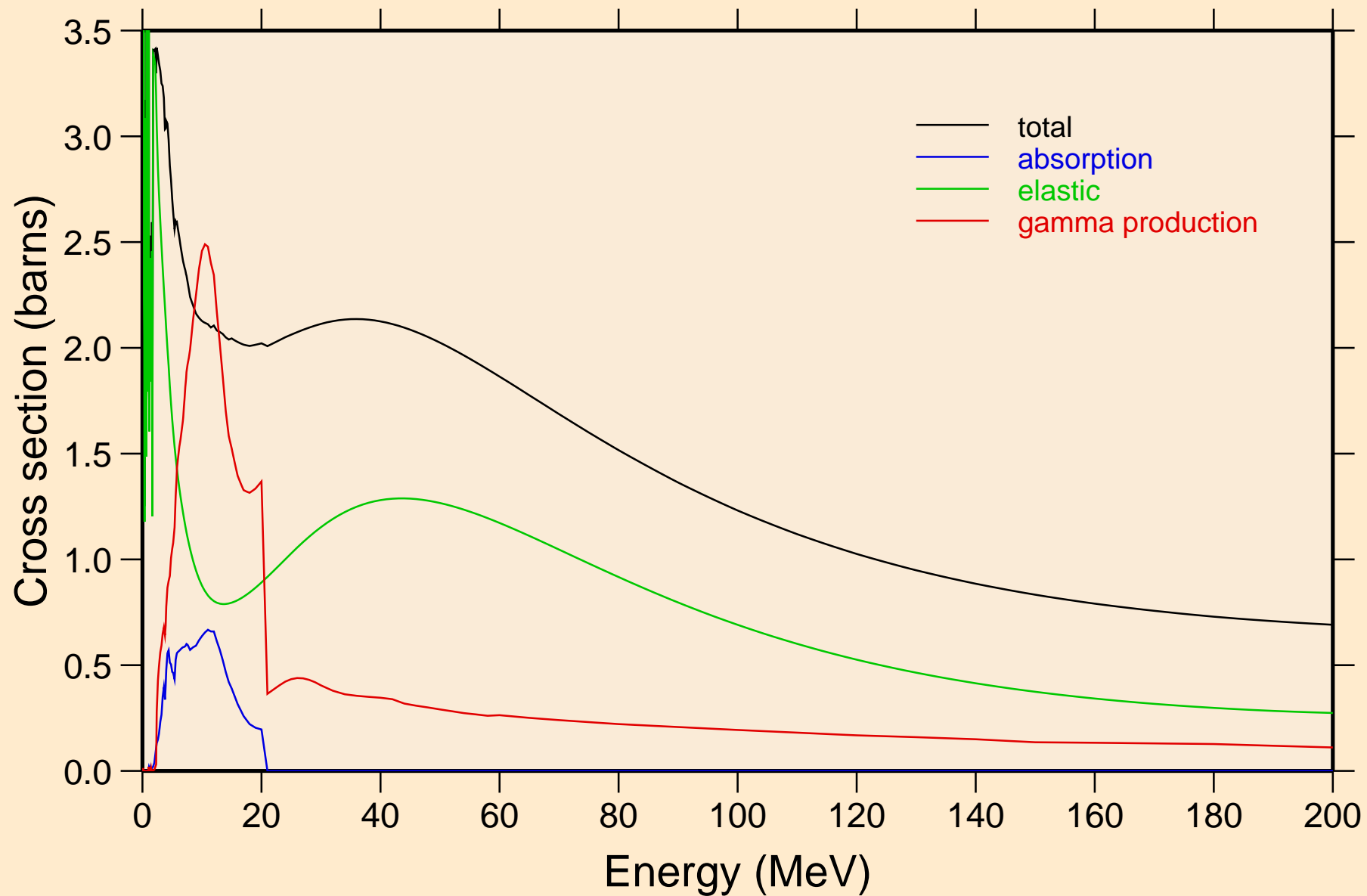

16-S-32 FOR FENDL-3.1 FROM TENDL-2010 WITH NJOY2012.50+ Heating

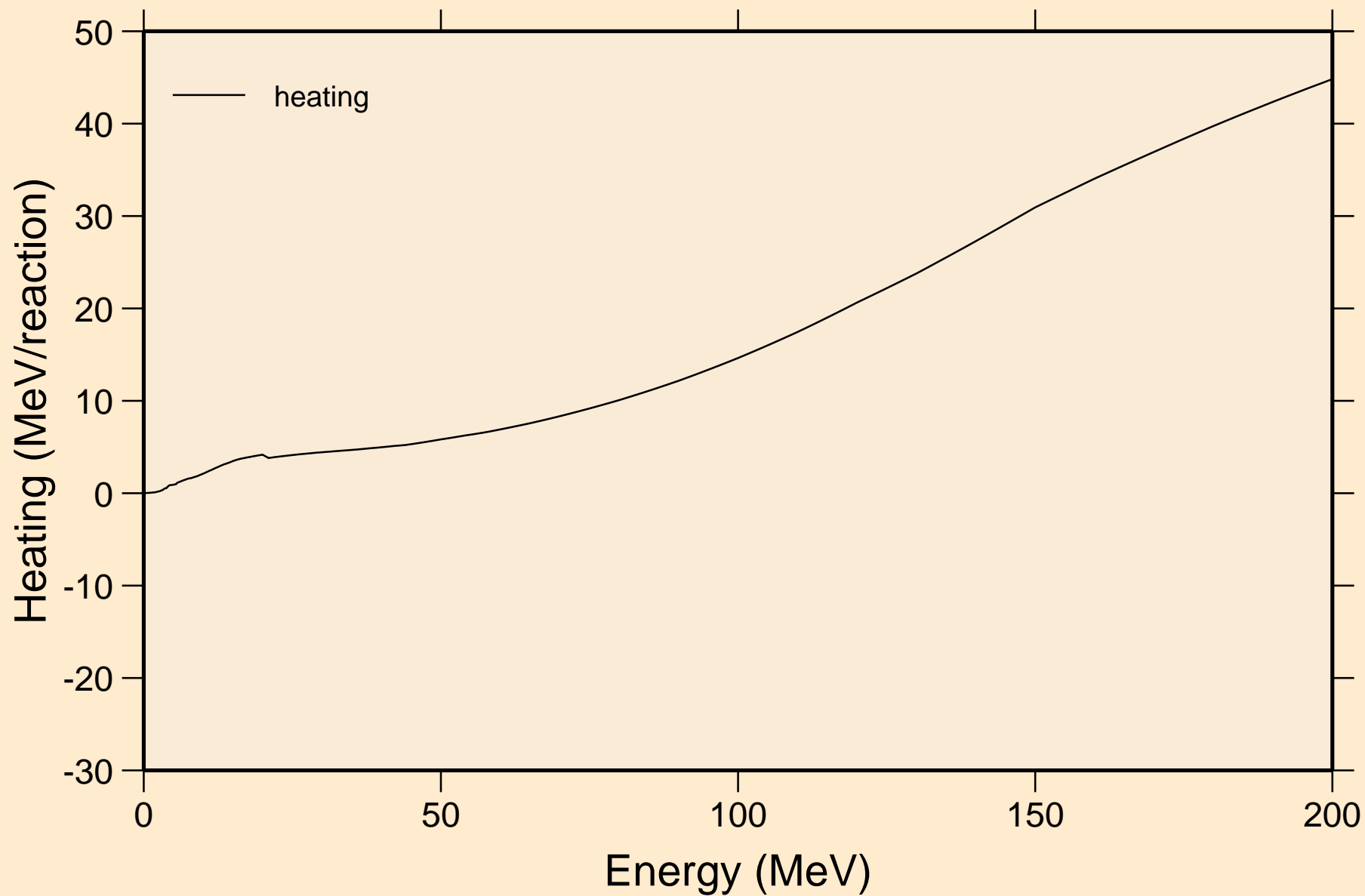

16-S-32 FOR FENDL-3.1 FROM TENDL-2010 WITH NJOY2012.50+ Damage

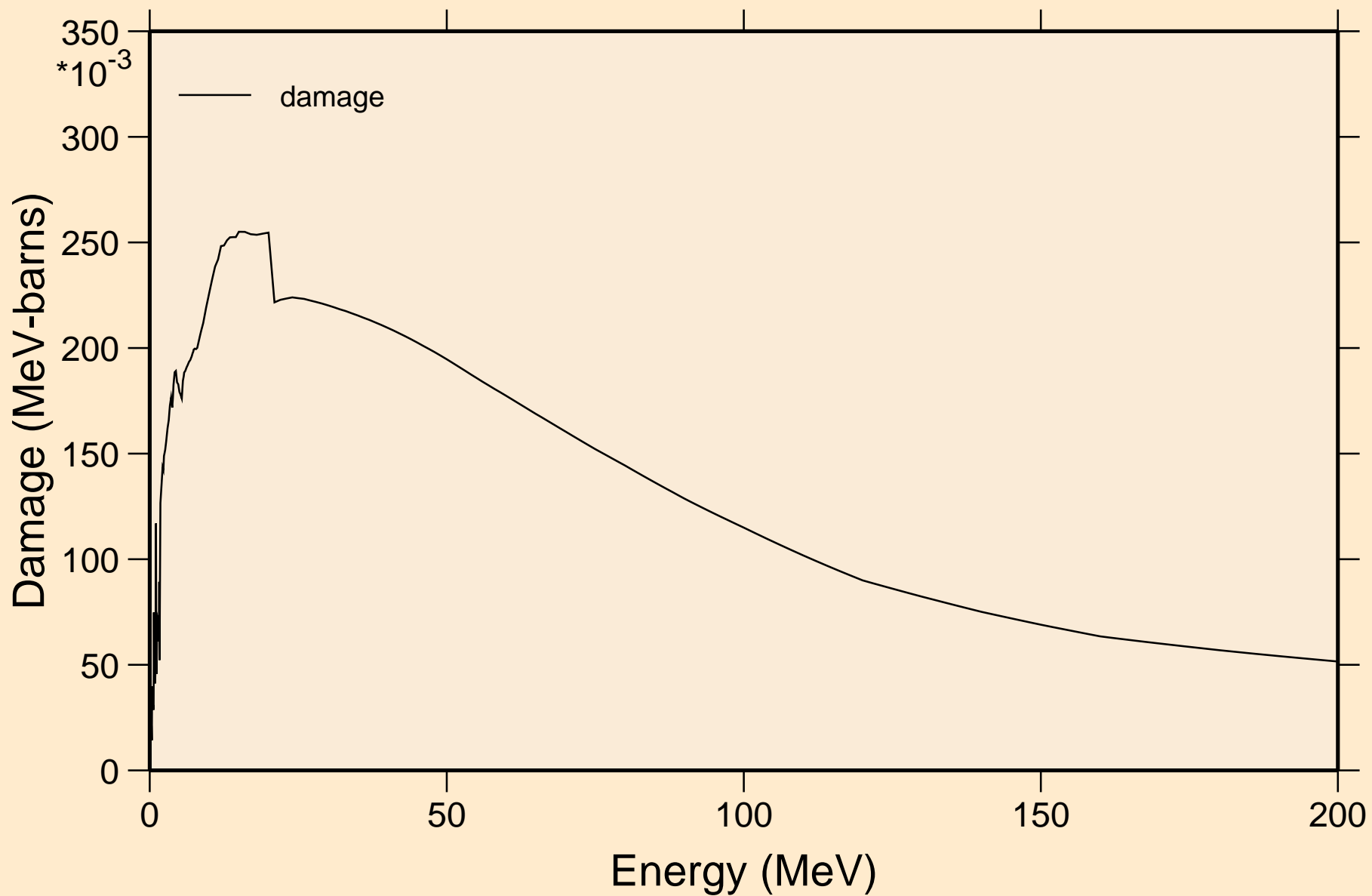

16-S-32 FOR FENDL-3.1 FROM TENDL-2010 WITH NJOY2012.50+
Non-threshold reactions

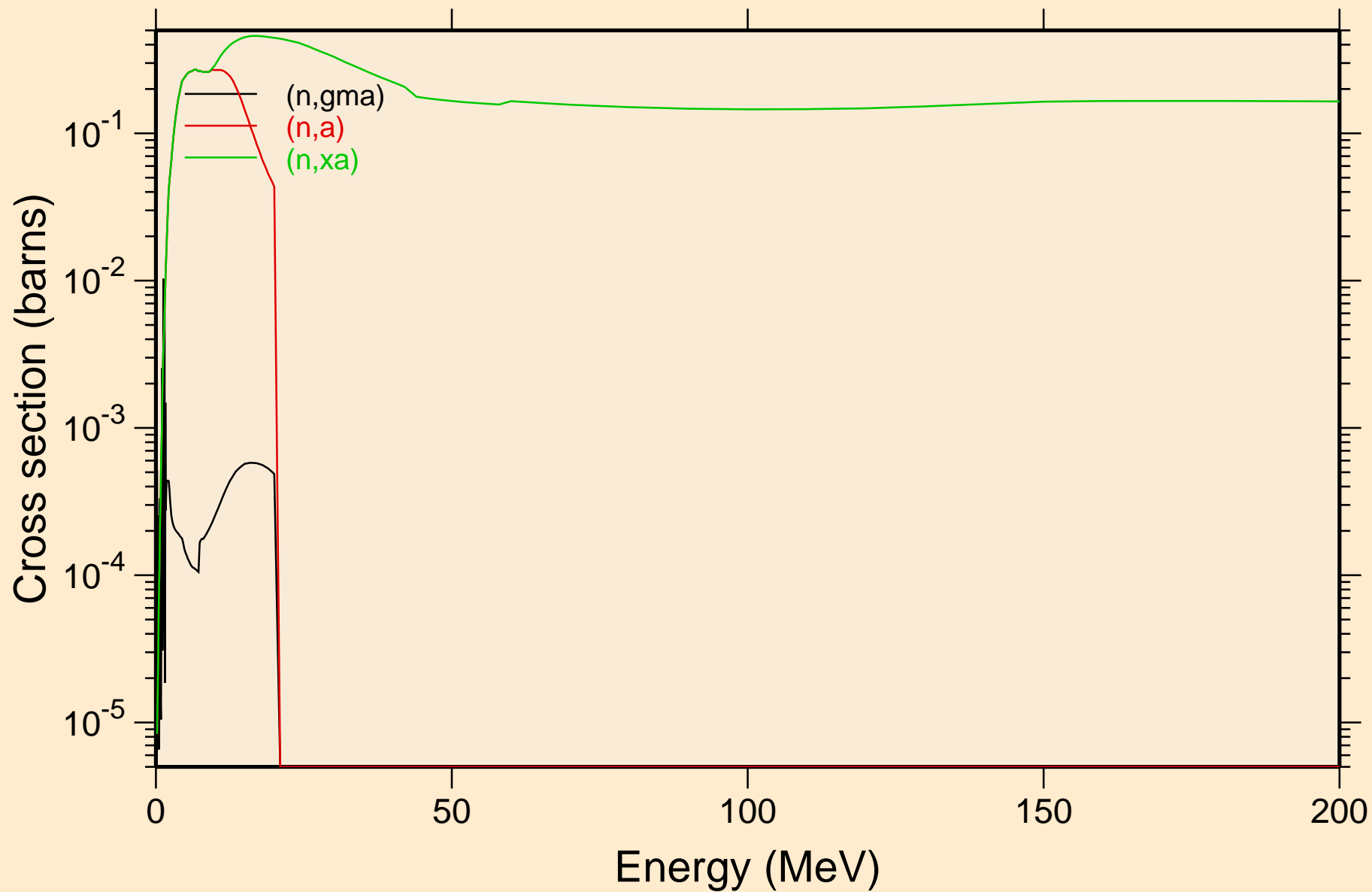

16-S-32 FOR FENDL-3.1 FROM TENDL-2010 WITH NJOY2012.50+

Inelastic levels

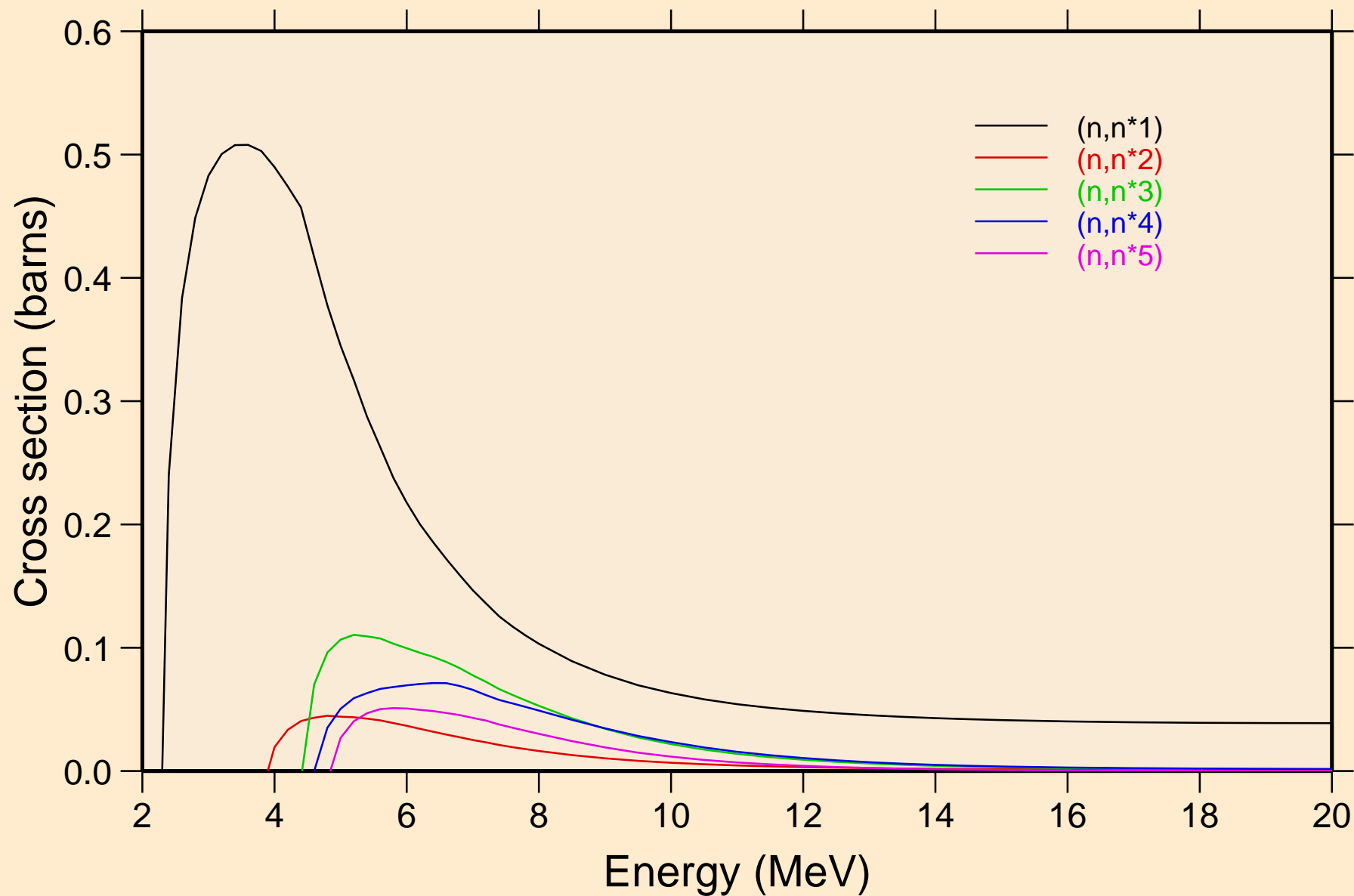

16-S-32 FOR FENDL-3.1 FROM TENDL-2010 WITH NJOY2012.50+ Inelastic levels

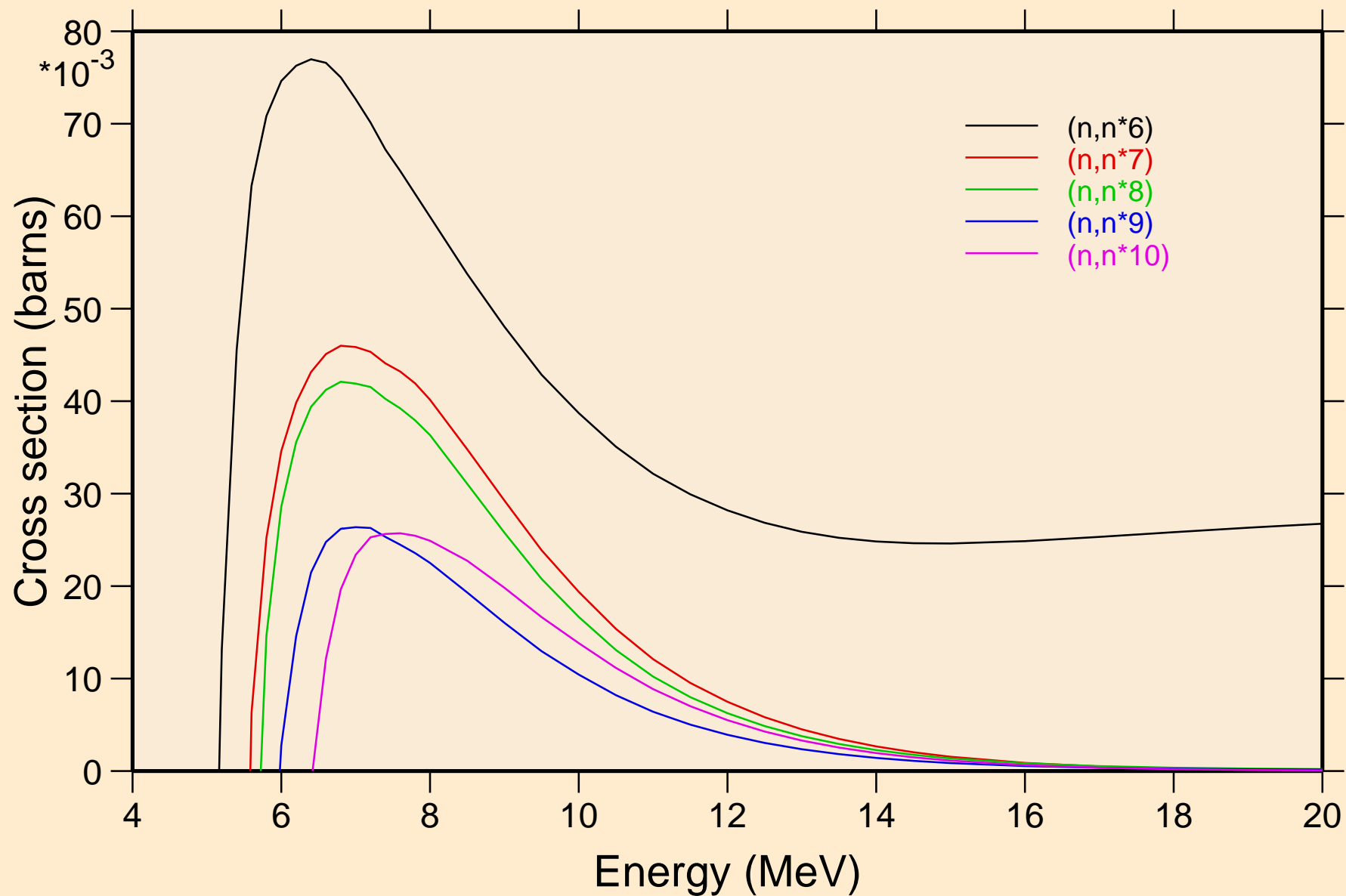

16-S-32 FOR FENDL-3.1 FROM TENDL-2010 WITH NJOY2012.50+ Inelastic levels

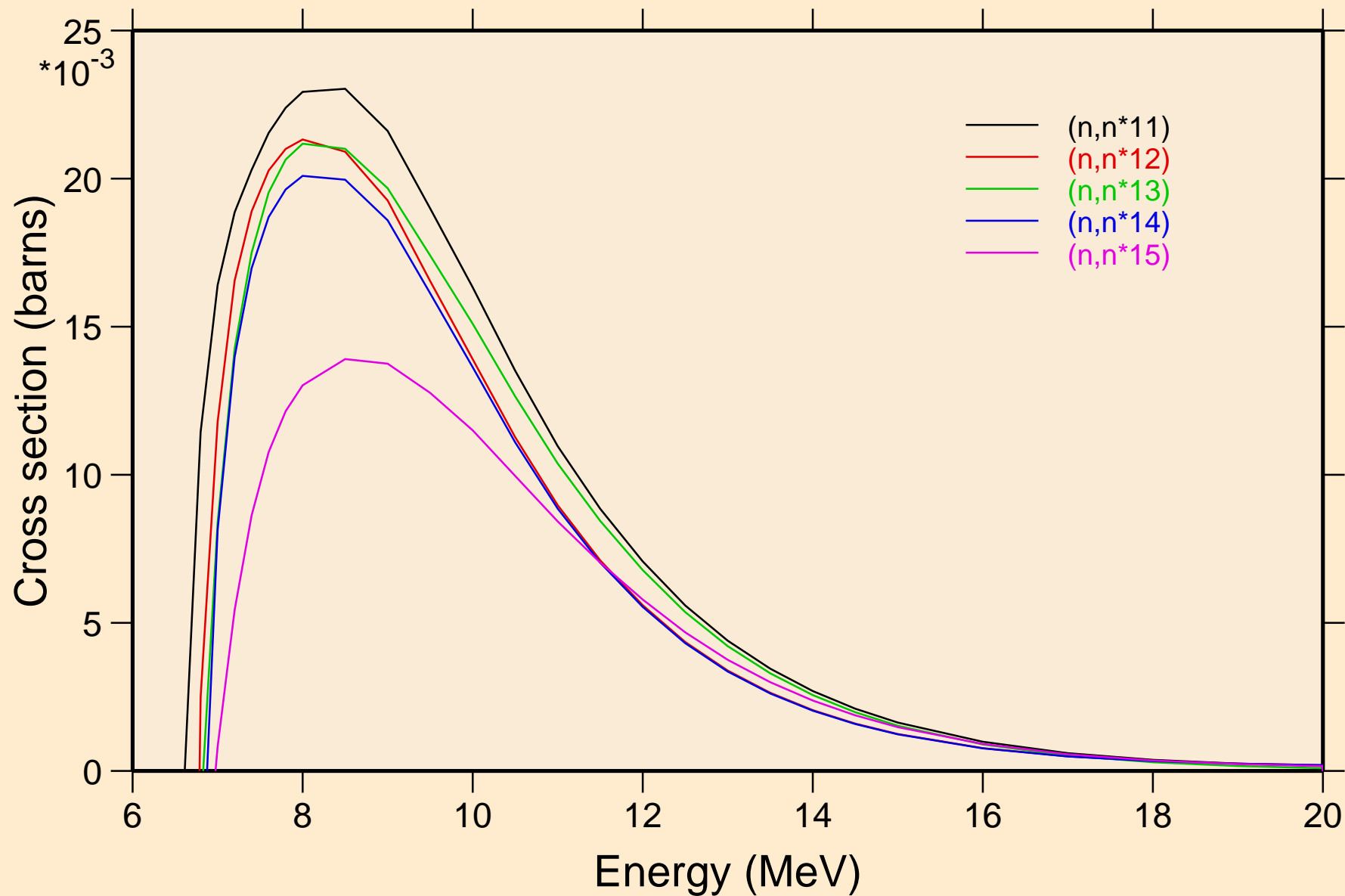

16-S-32 FOR FENDL-3.1 FROM TENDL-2010 WITH NJOY2012.50+ Inelastic levels

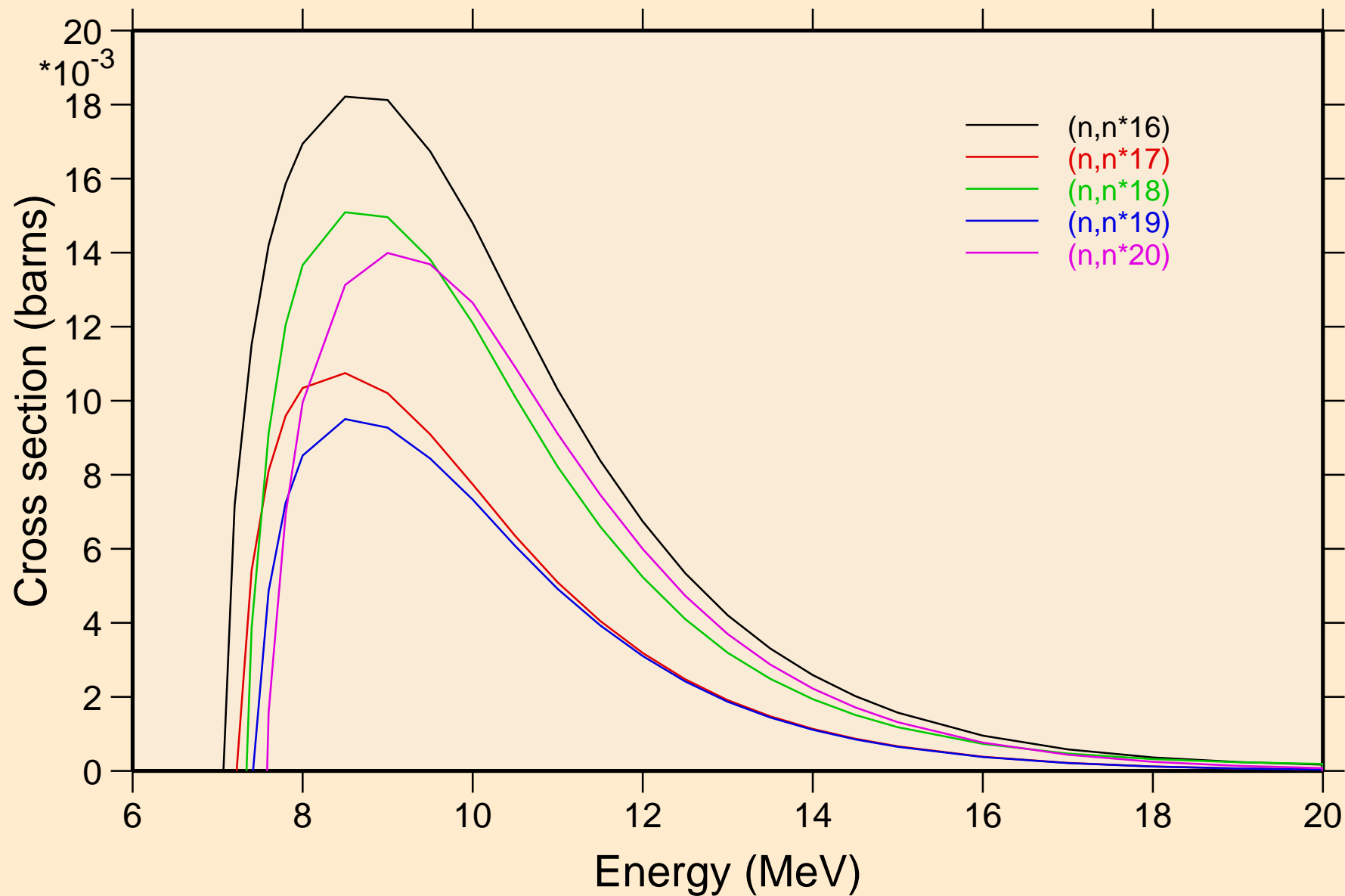

16-S-32 FOR FENDL-3.1 FROM TENDL-2010 WITH NJOY2012.50+

Threshold reactions

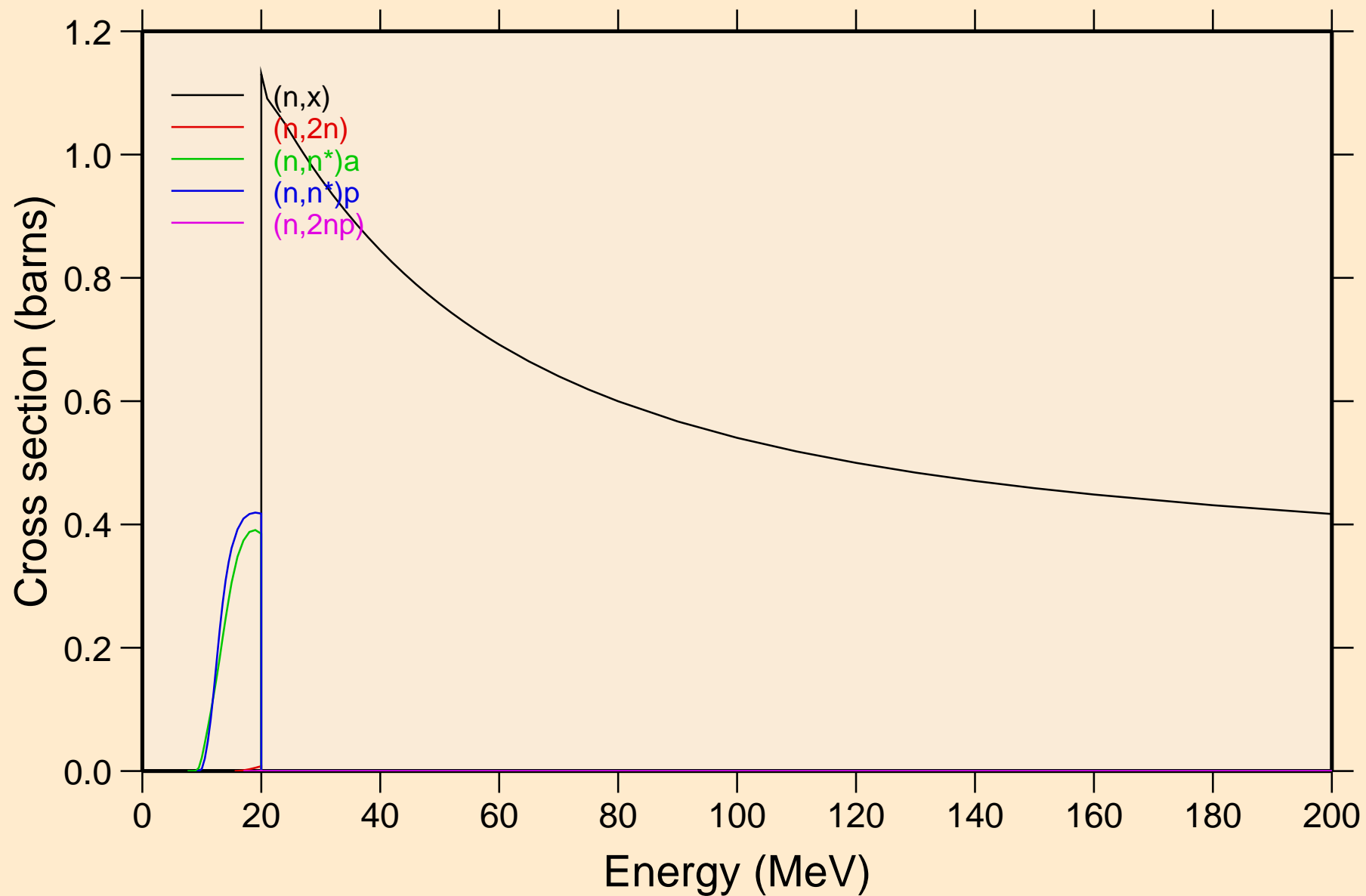

16-S-32 FOR FENDL-3.1 FROM TENDL-2010 WITH NJOY2012.50+

Threshold reactions

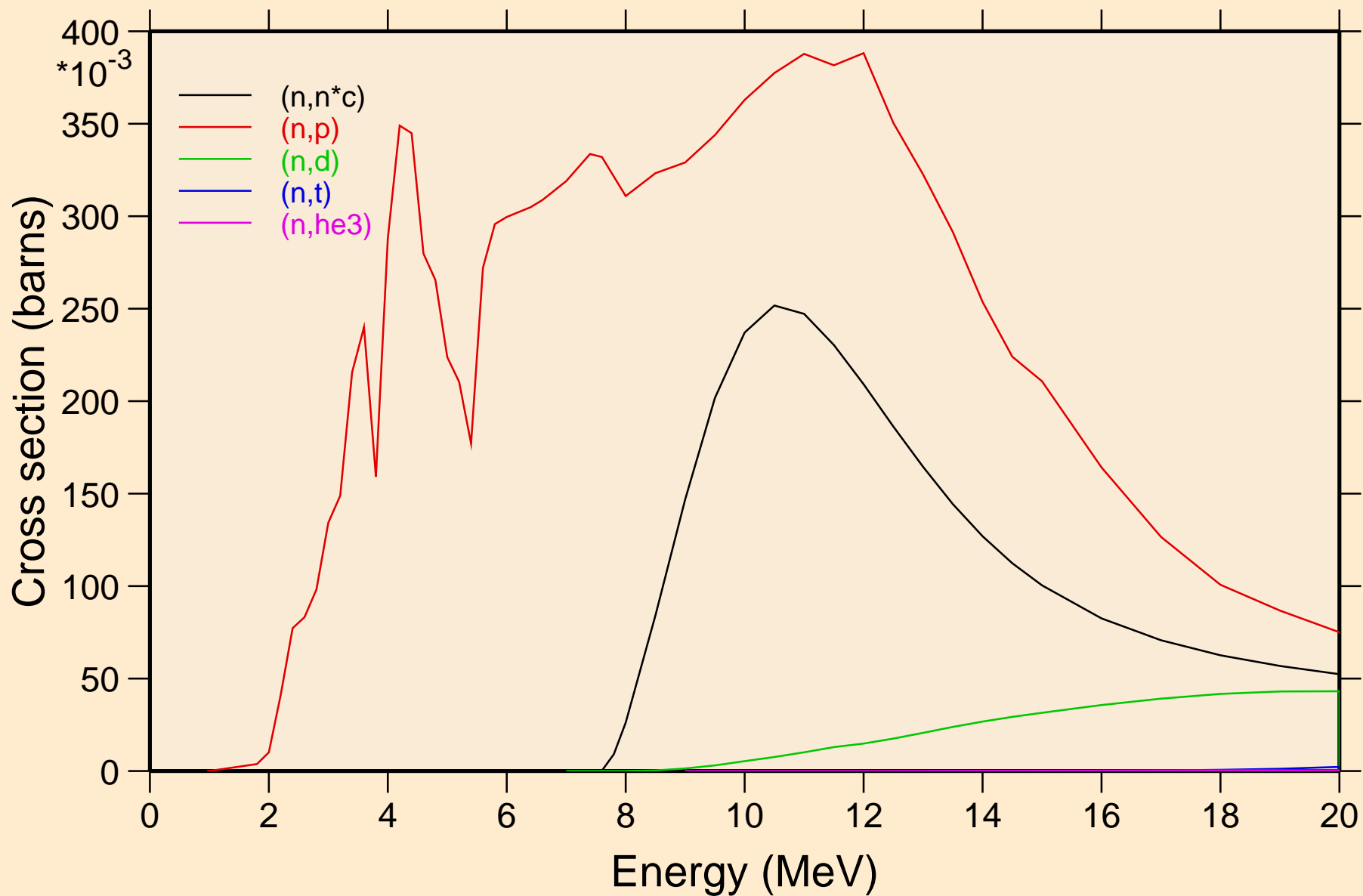

16-S-32 FOR FENDL-3.1 FROM TENDL-2010 WITH NJOY2012.50+ Threshold reactions

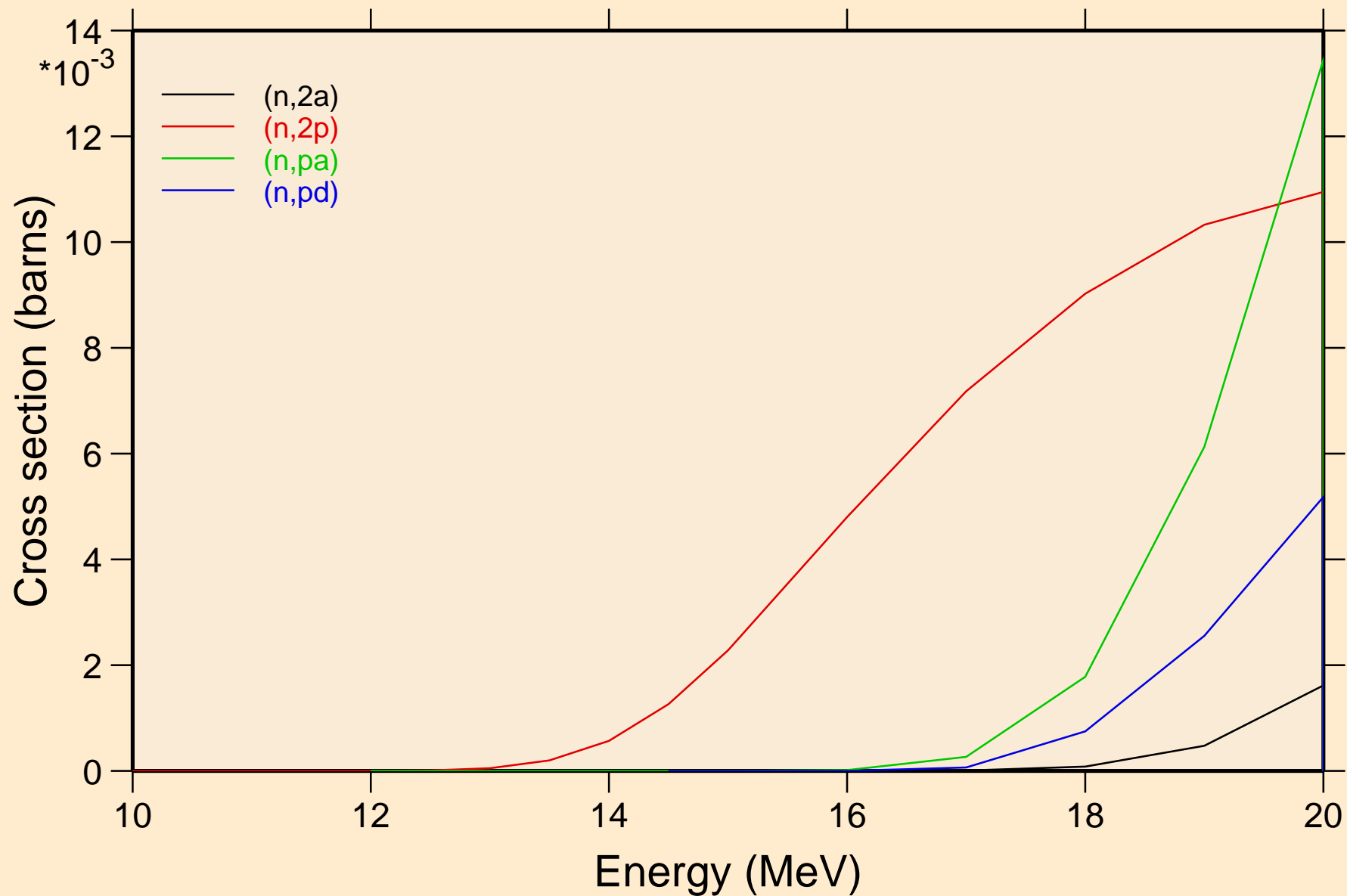

16-S-32 FOR FENDL-3.1 FROM TENDL-2010 WITH NJOY2012.50+

Threshold reactions

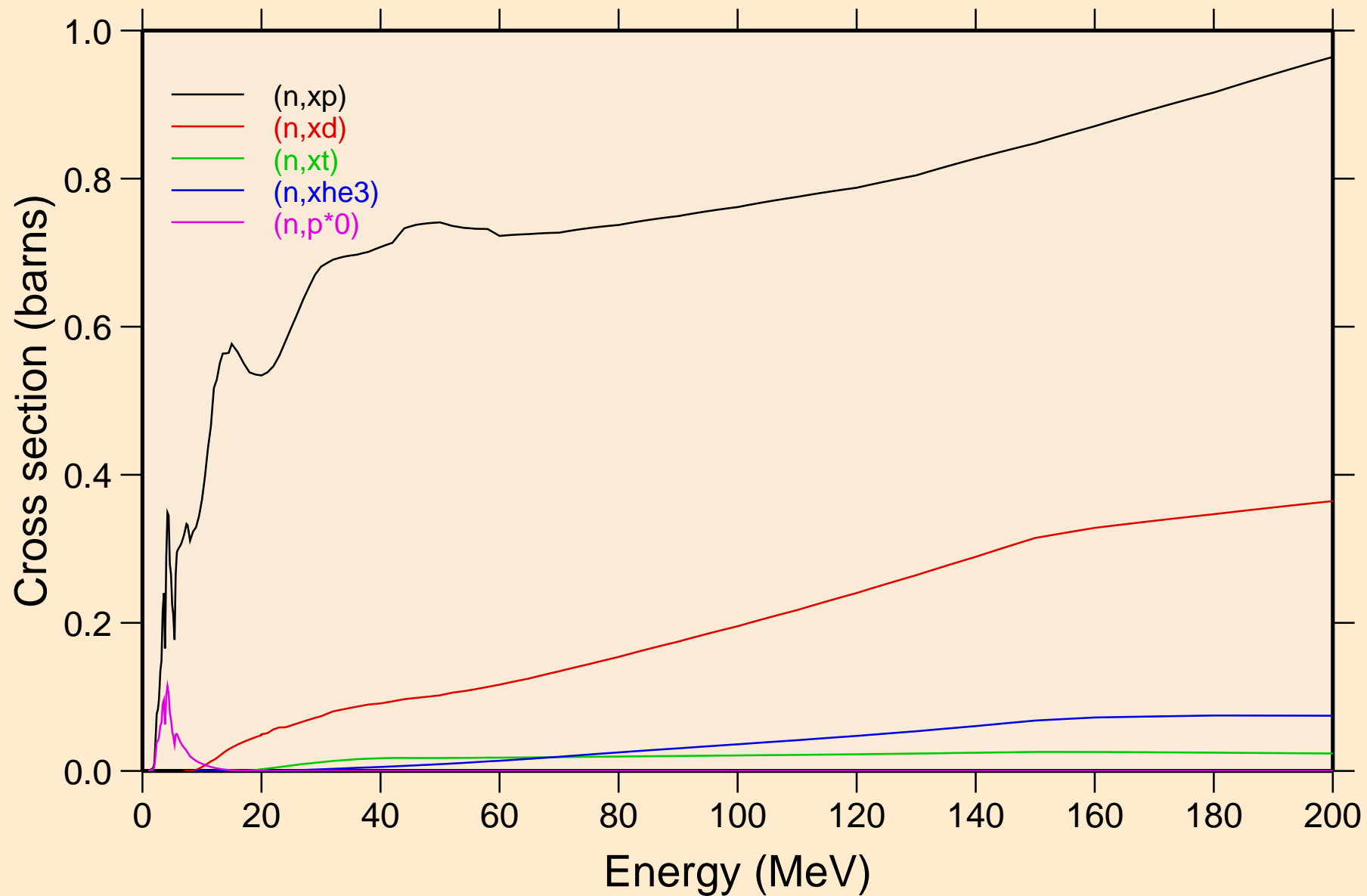

16-S-32 FOR FENDL-3.1 FROM TENDL-2010 WITH NJOY2012.50+

Threshold reactions

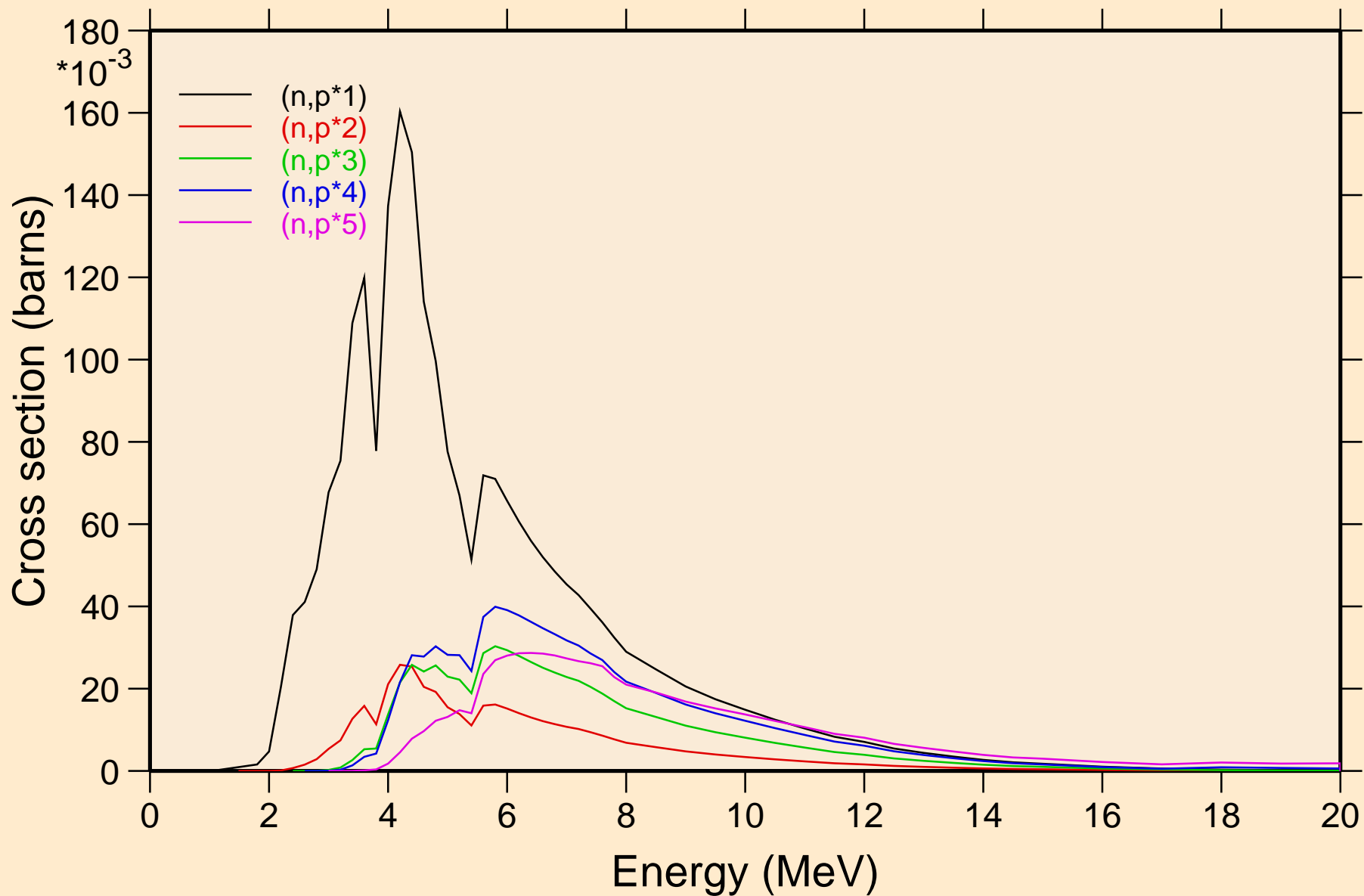

16-S-32 FOR FENDL-3.1 FROM TENDL-2010 WITH NJOY2012.50+ Threshold reactions

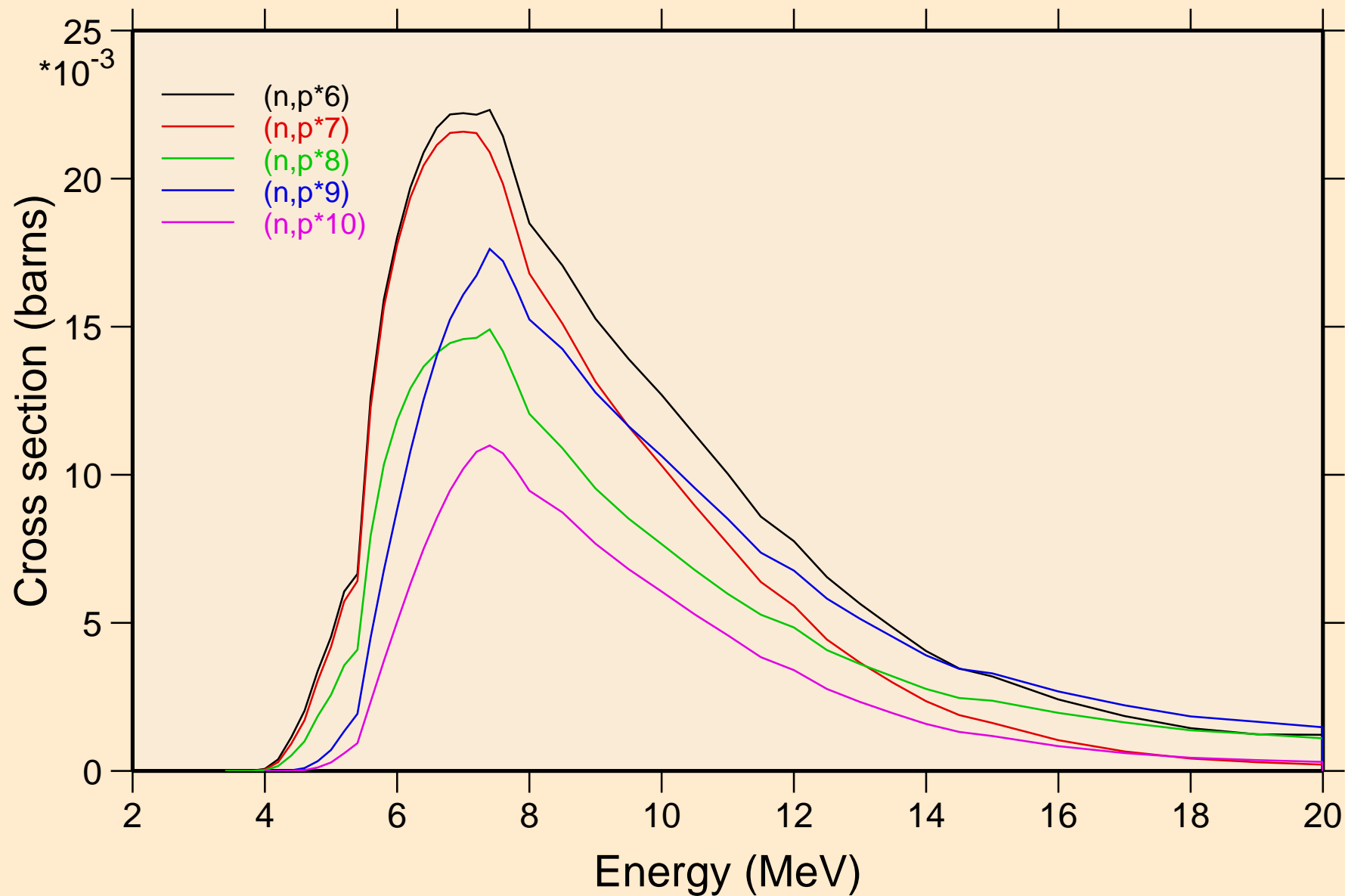

16-S-32 FOR FENDL-3.1 FROM TENDL-2010 WITH NJOY2012.50+
Threshold reactions

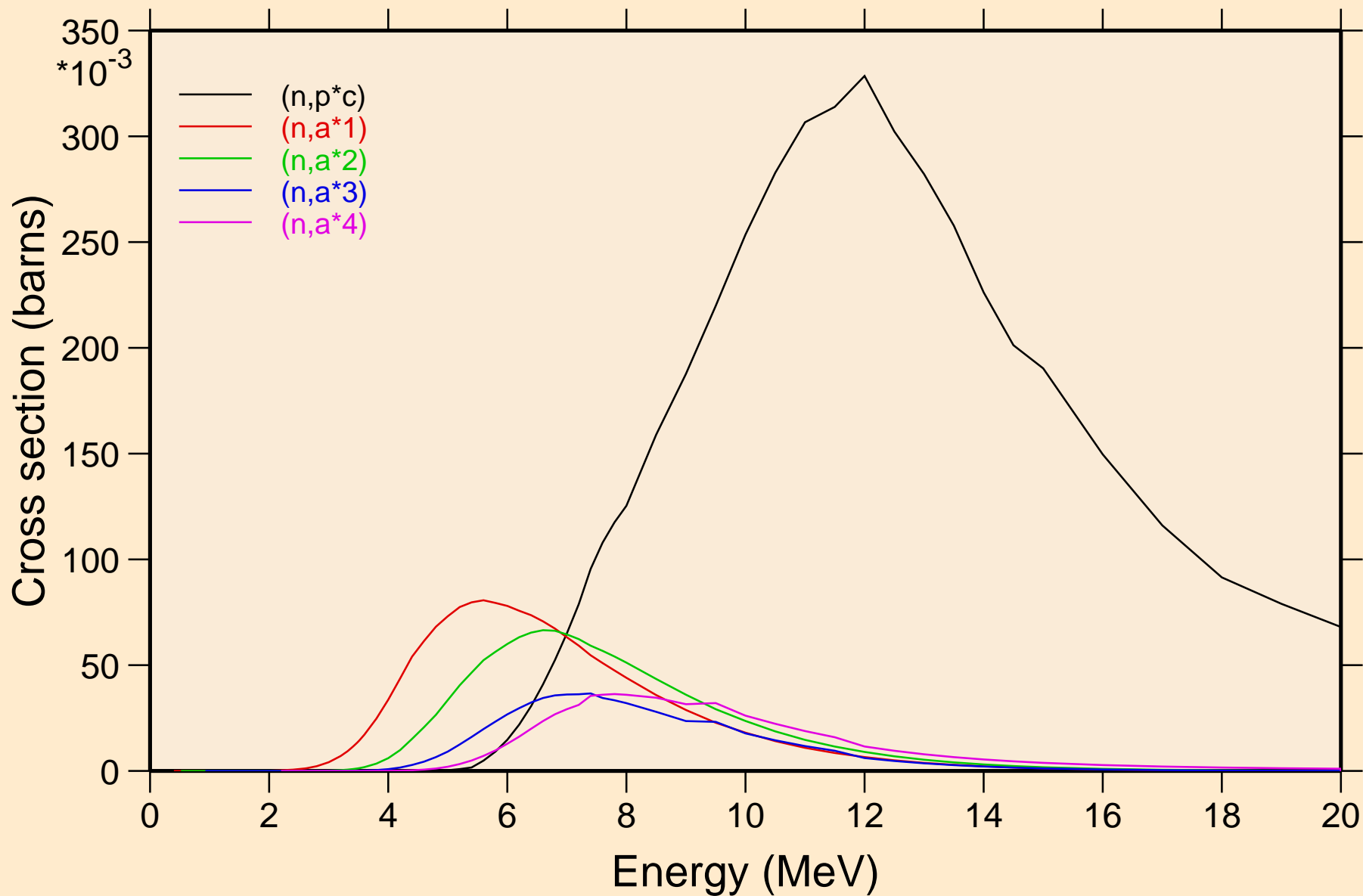

16-S-32 FOR FENDL-3.1 FROM TENDL-2010 WITH NJOY2012.50+

Threshold reactions

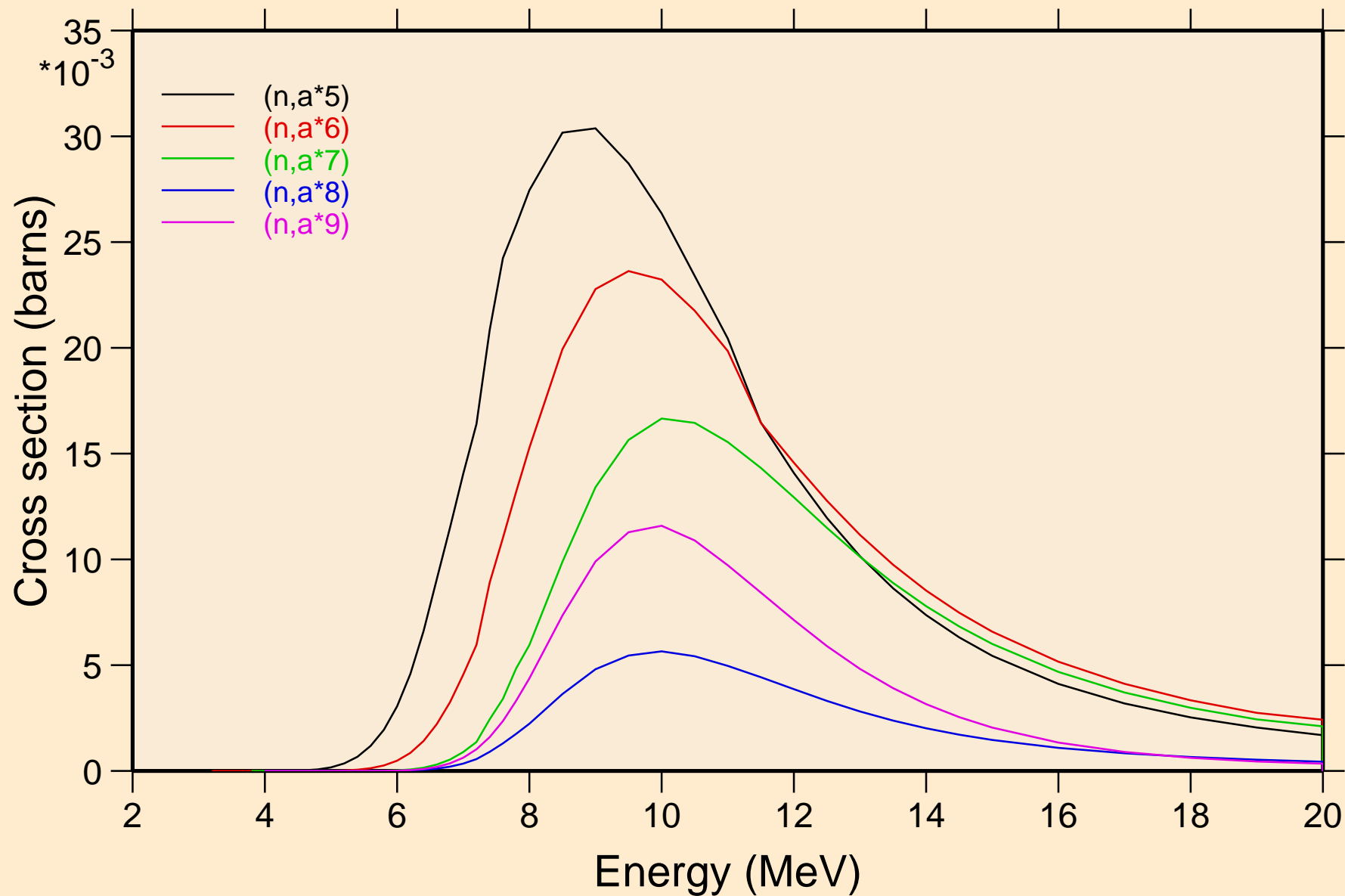

16-S-32 FOR FENDL-3.1 FROM TENDL-2010 WITH NJOY2012.50+
Threshold reactions

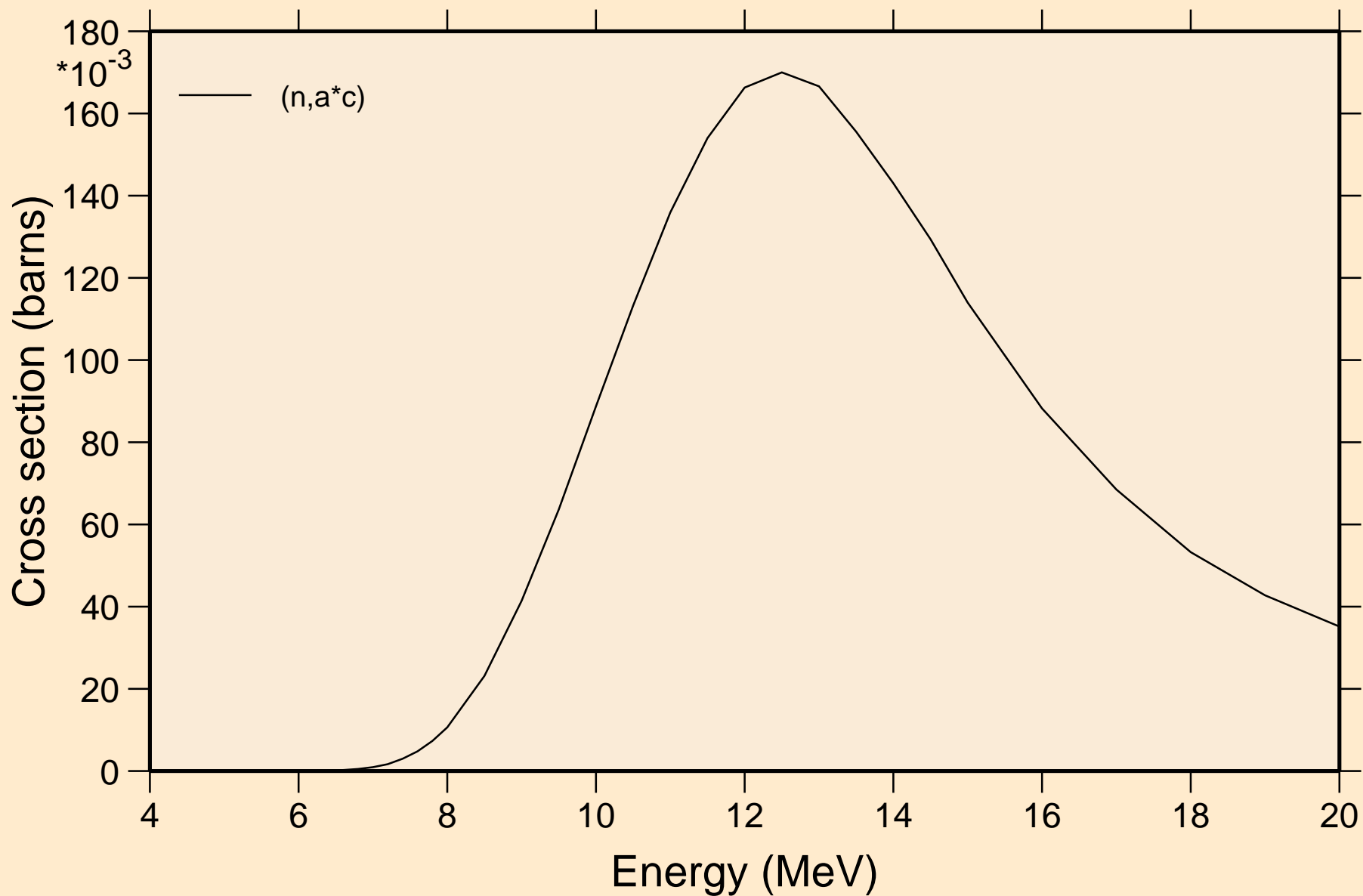

16-S-32 FOR FENDL-3.1 FROM TENDL-2010 WITH NJOY2012.50+
angular distribution for elastic

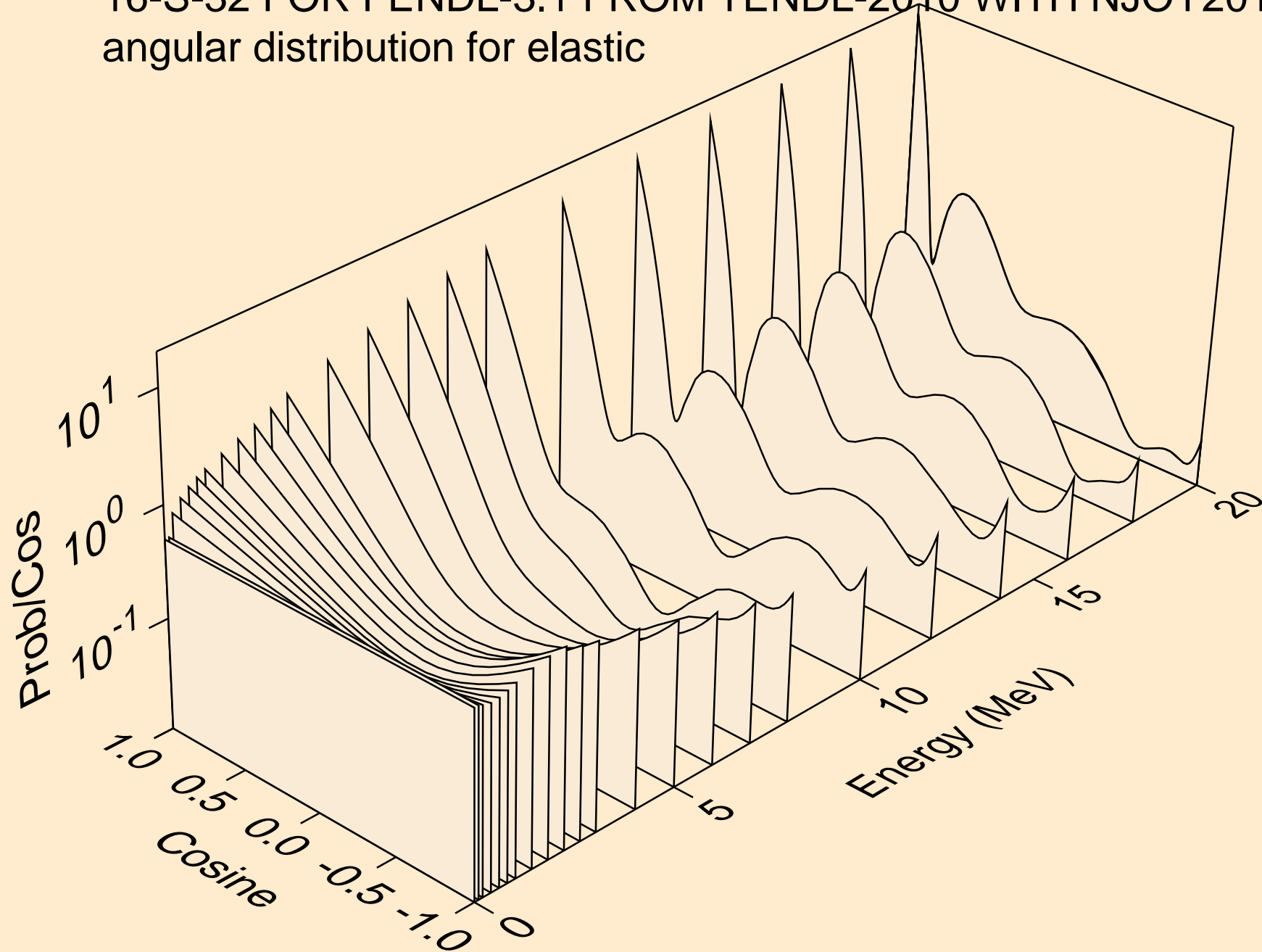

16-S-32 FOR FENDL-3.1 FROM TENDL-2010 WITH NJOY2012.50+
angular distribution for elastic

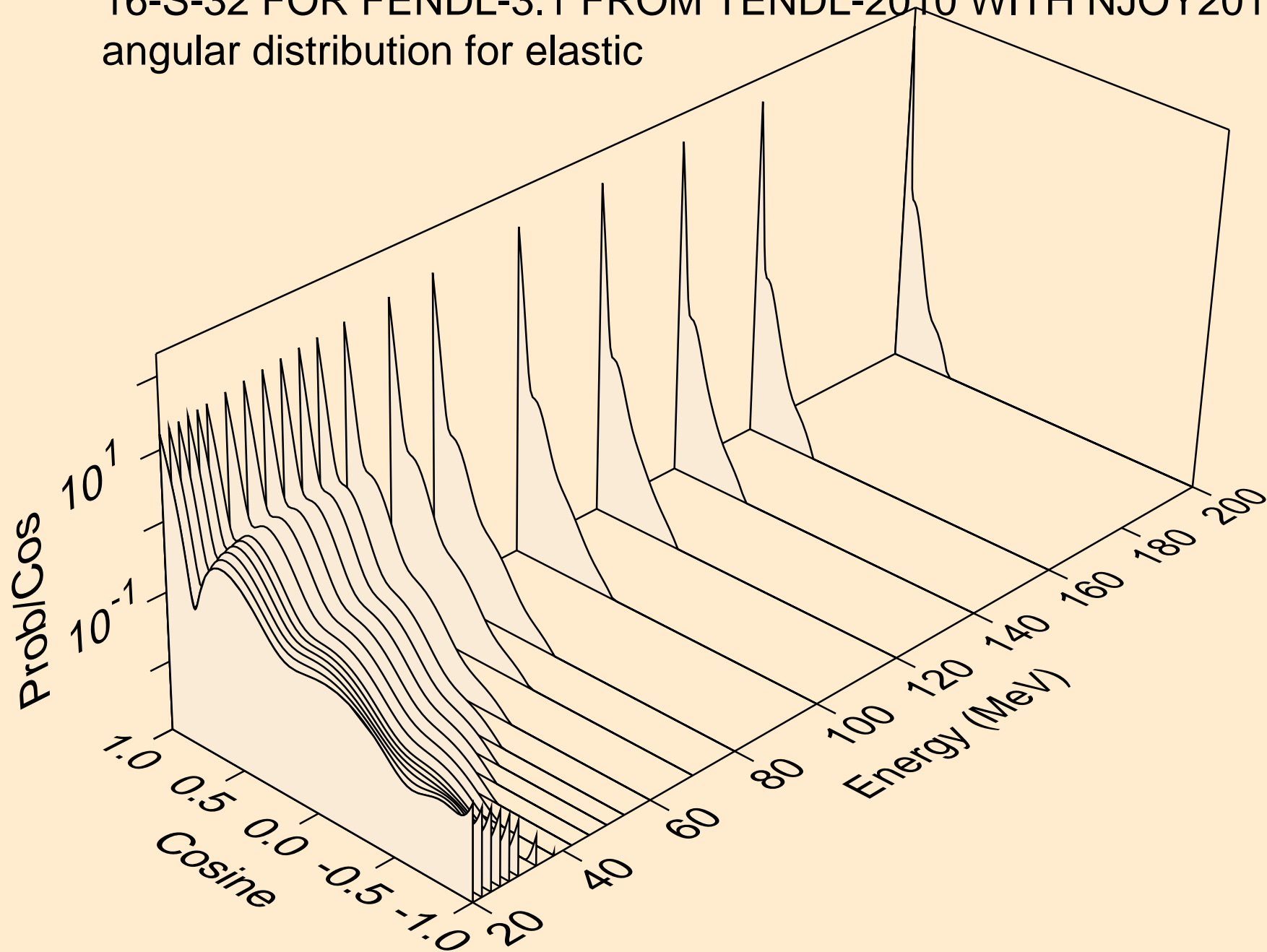

16-S-32 FOR FENDL-3.1 FROM TENDL-2010 WITH NJOY2012.50+
angular distribution for (n,n*1)

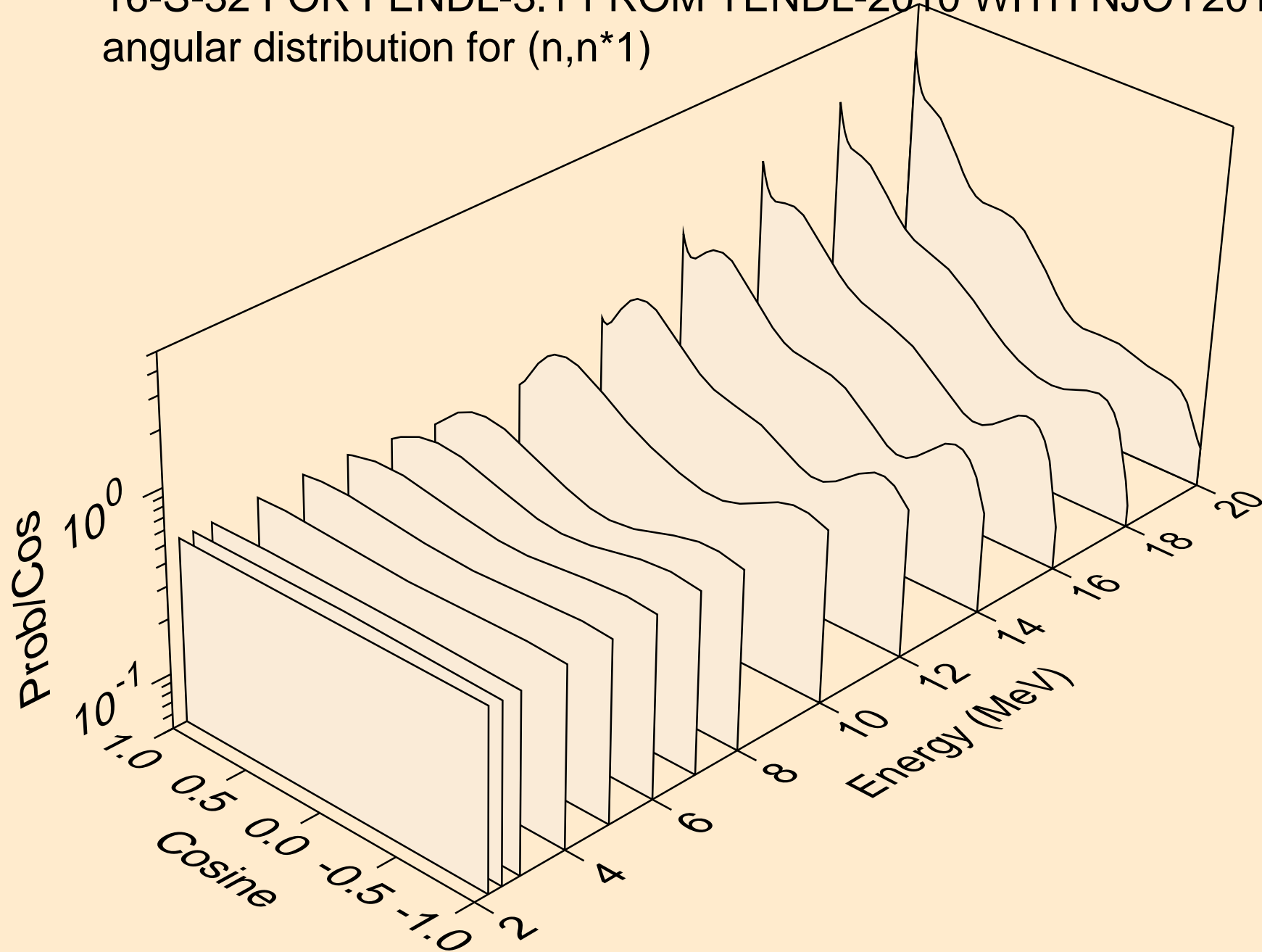

16-S-32 FOR FENDL-3.1 FROM TENDL-2010 WITH NJOY2012.50+
angular distribution for (n,n*2)

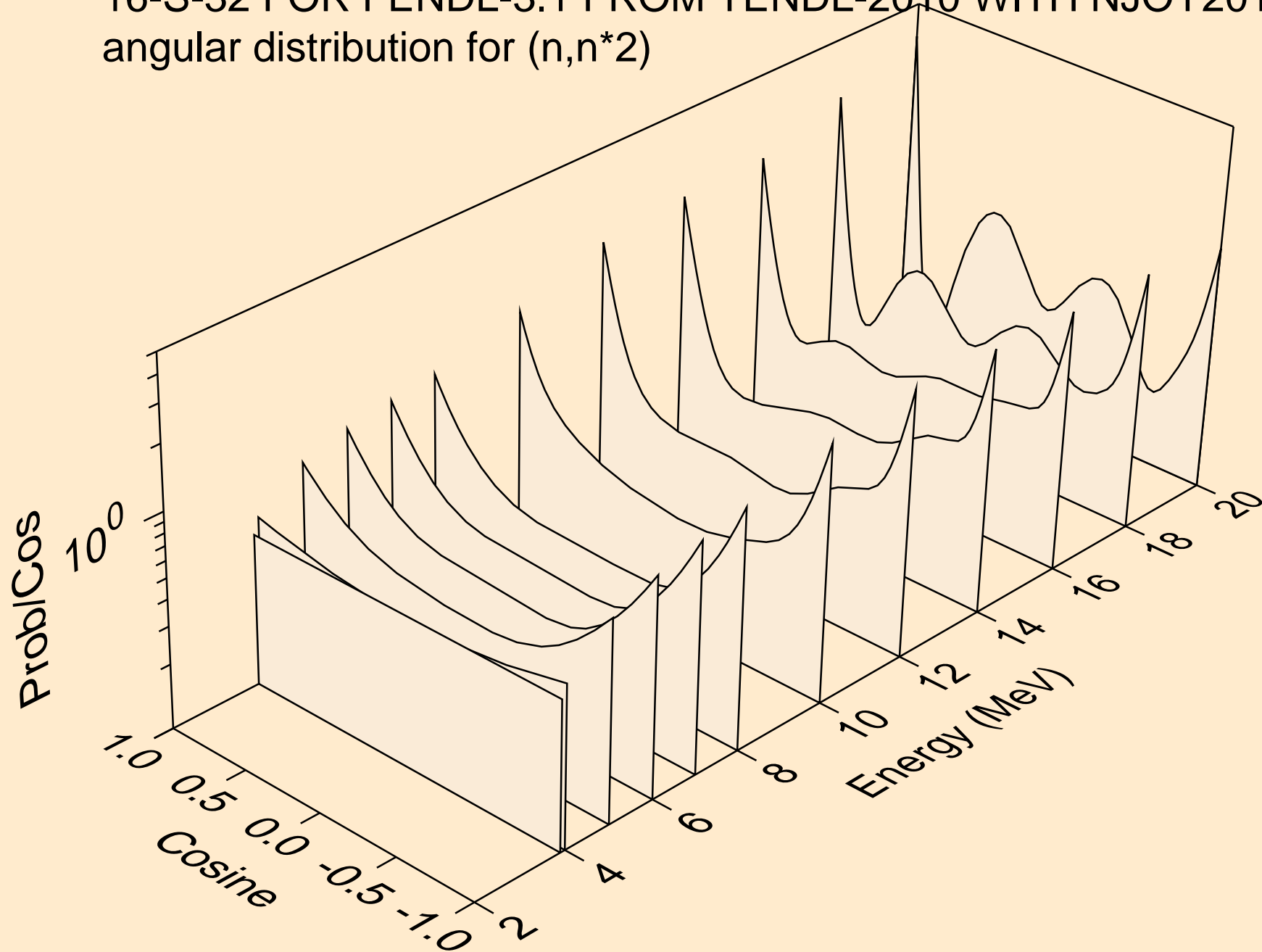

16-S-32 FOR FENDL-3.1 FROM TENDL-2010 WITH NJOY2012.50+
angular distribution for (n,n*3)

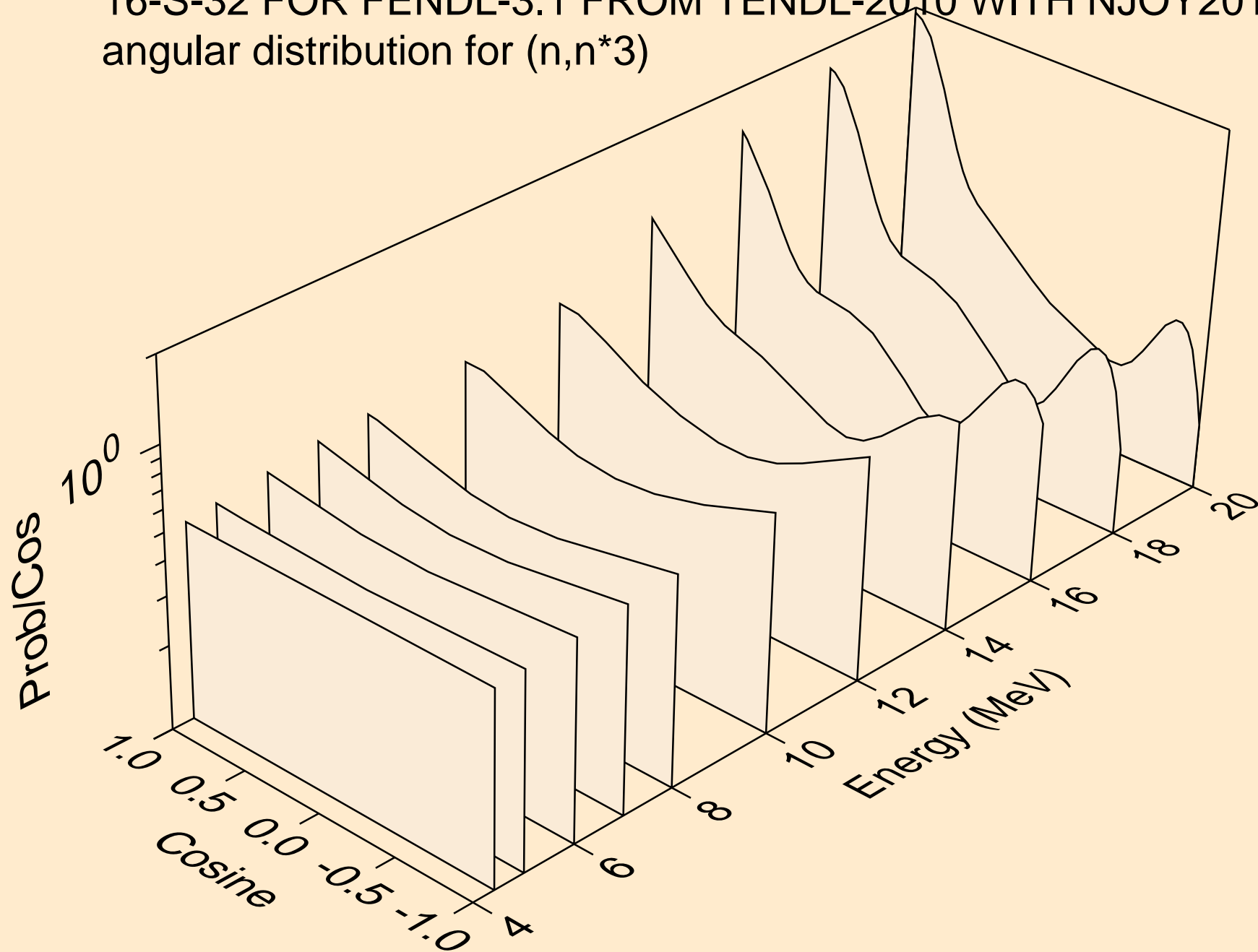

16-S-32 FOR FENDL-3.1 FROM TENDL-2010 WITH NJOY2012.50+
angular distribution for (n,n*4)

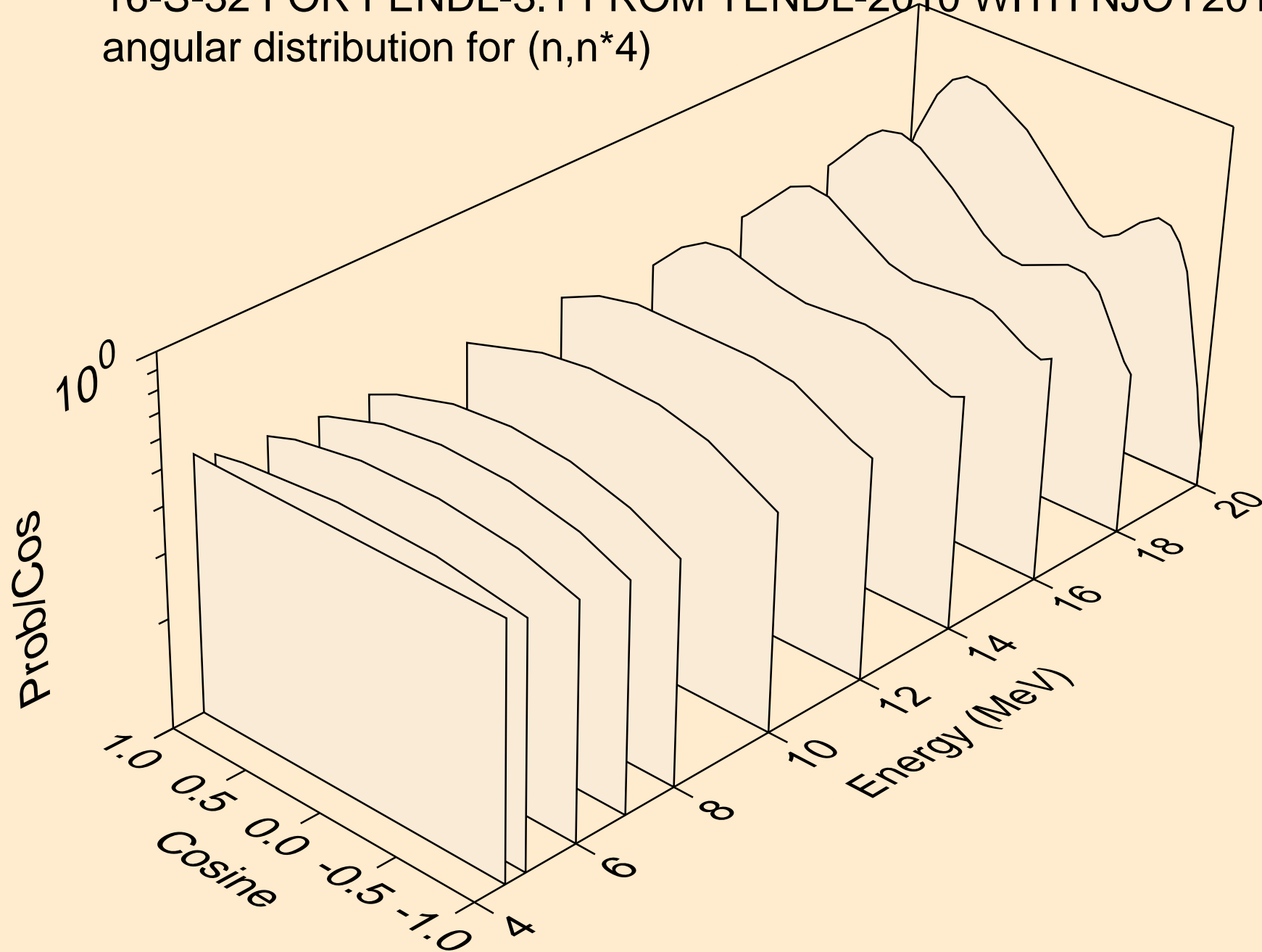

16-S-32 FOR FENDL-3.1 FROM TENDL-2010 WITH NJOY2012.50+
angular distribution for (n,n*5)

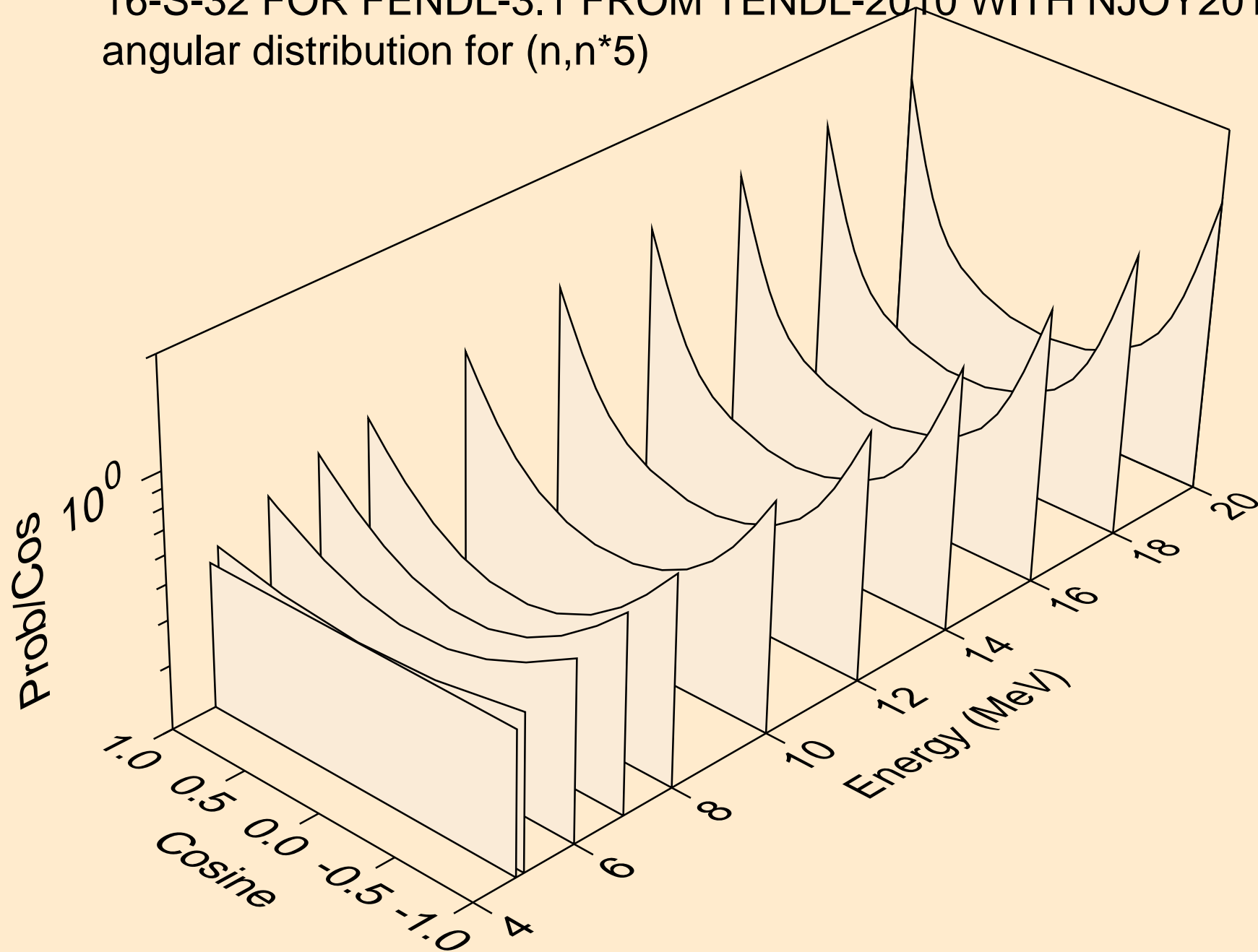

16-S-32 FOR FENDL-3.1 FROM TENDL-2010 WITH NJOY2012.50+
angular distribution for (n,n*6)

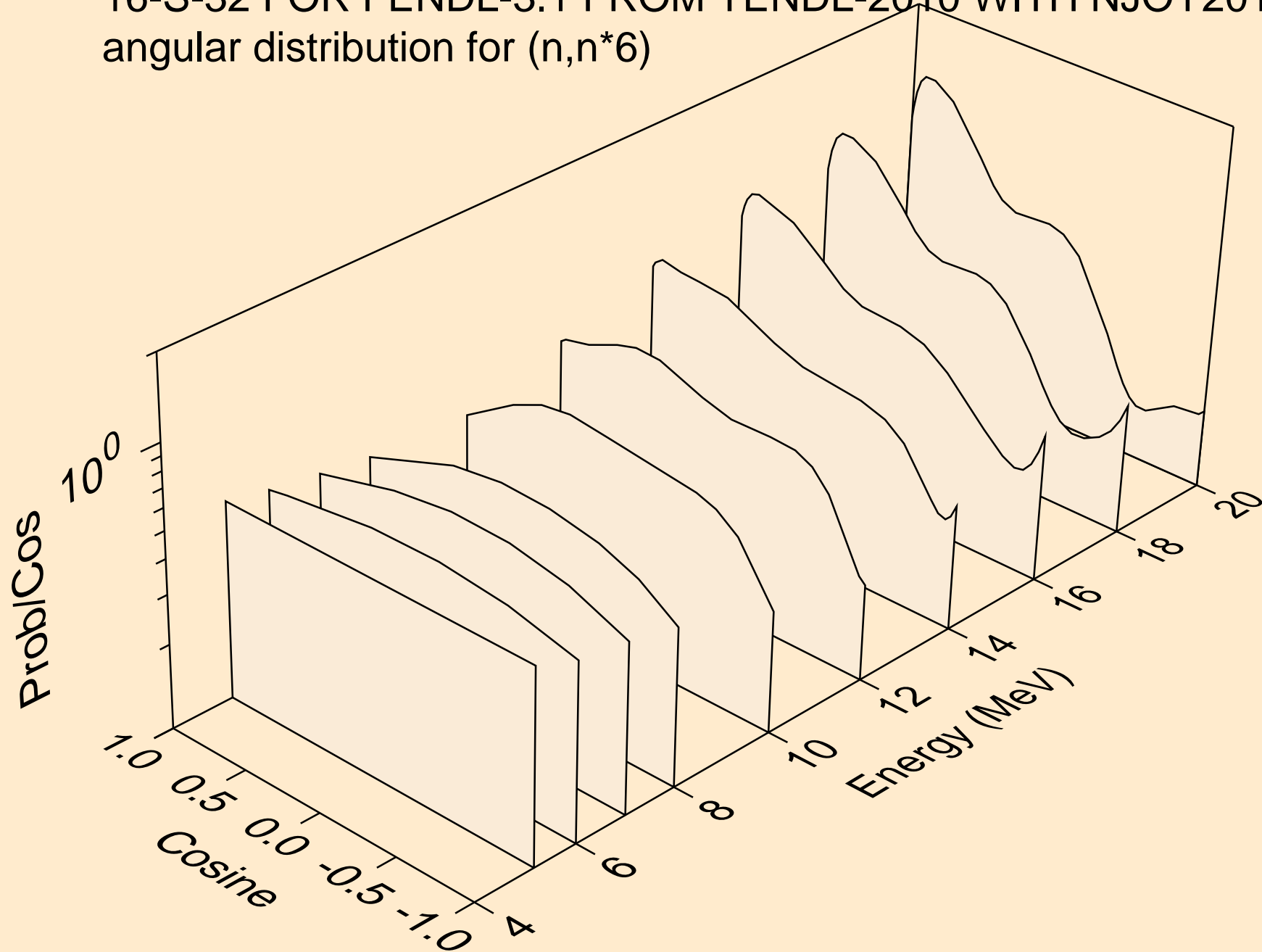

16-S-32 FOR FENDL-3.1 FROM TENDL-2010 WITH NJOY2012.50+
angular distribution for (n,n*7)

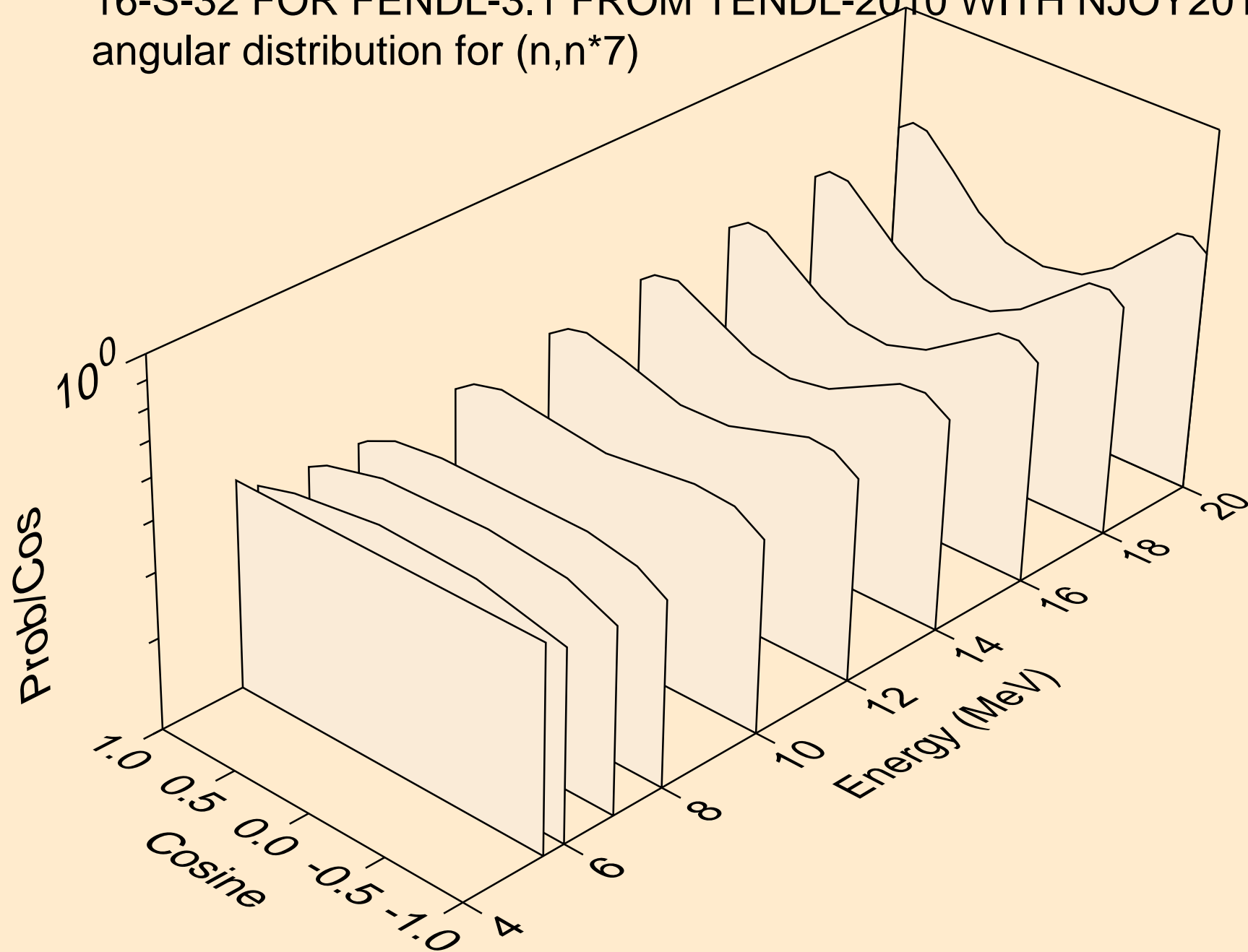

16-S-32 FOR FENDL-3.1 FROM TENDL-2010 WITH NJOY2012.50+
angular distribution for (n,n*8)

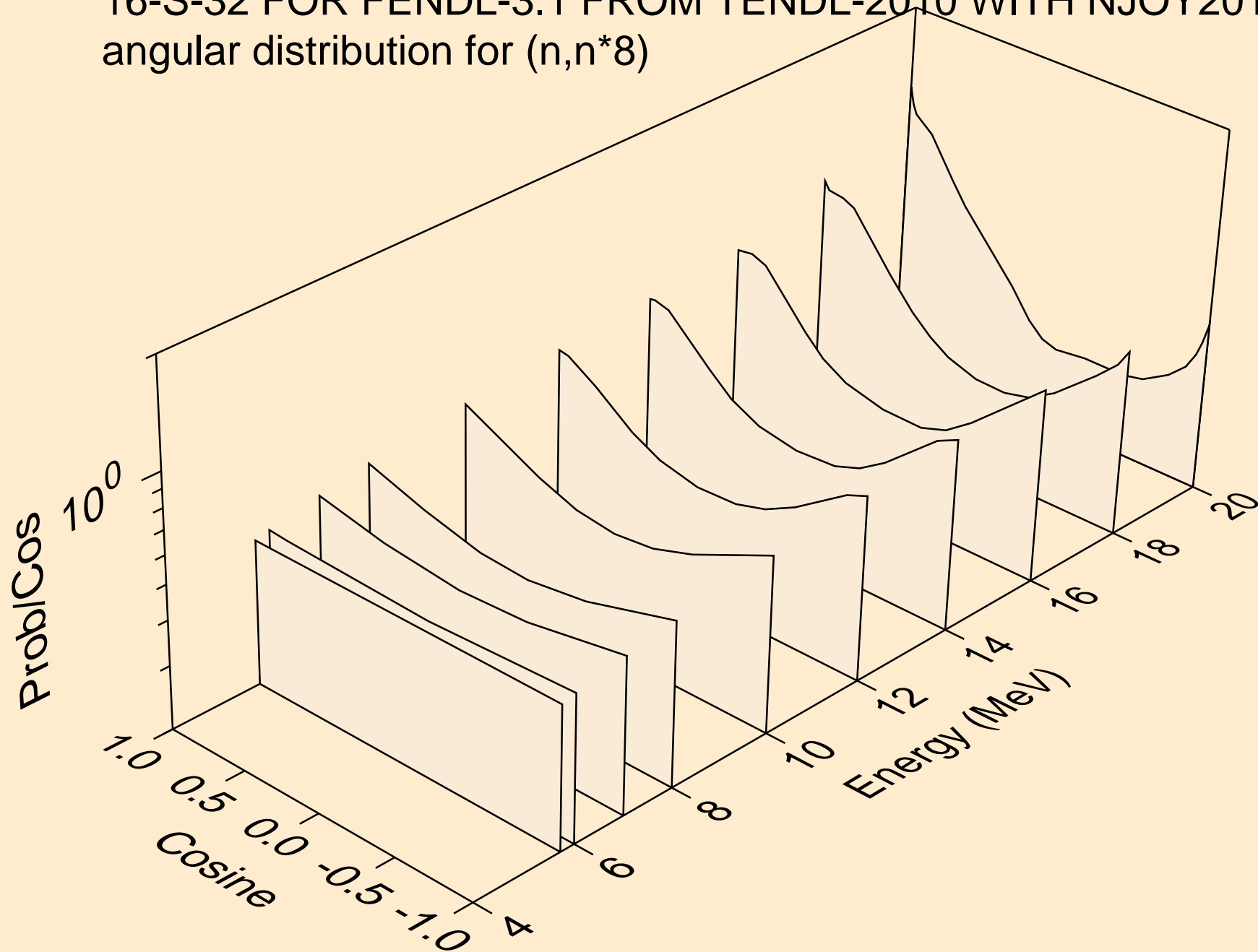

16-S-32 FOR FENDL-3.1 FROM TENDL-2010 WITH NJOY2012.50+
angular distribution for (n,n*9)

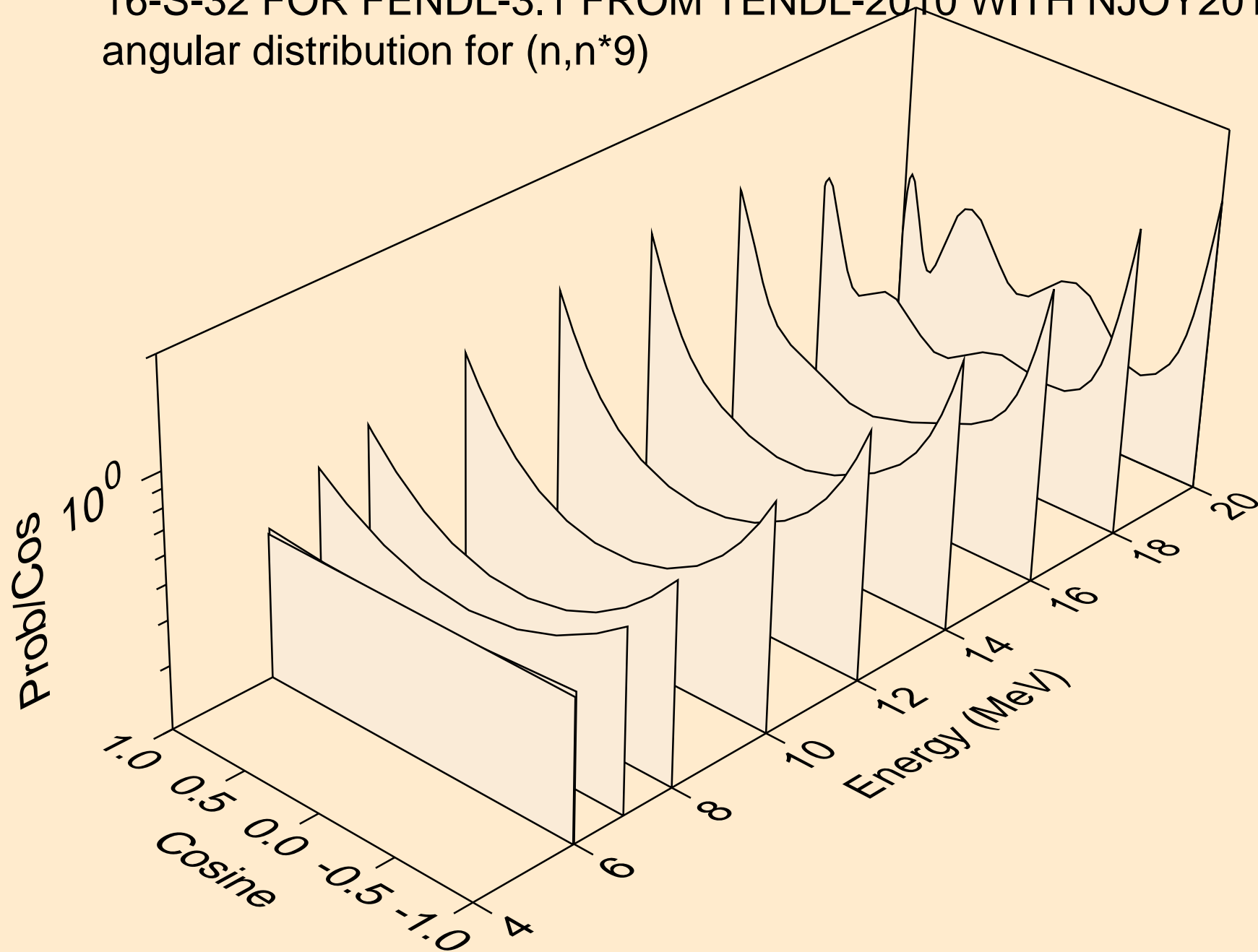

16-S-32 FOR FENDL-3.1 FROM TENDL-2010 WITH NJOY2012.50+
angular distribution for (n,n*10)

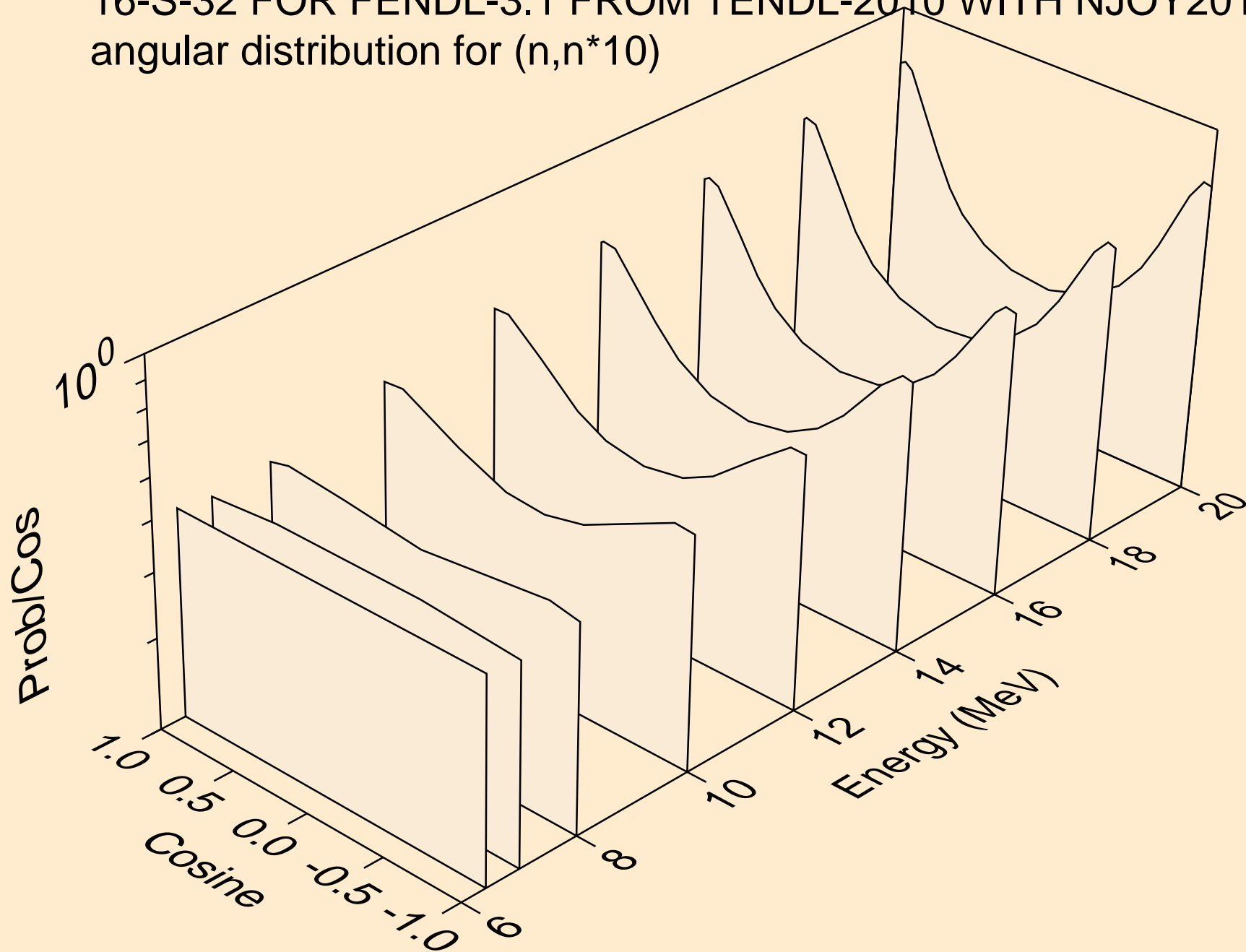

16-S-32 FOR FENDL-3.1 FROM TENDL-2010 WITH NJOY2012.50+
angular distribution for (n,n*11)

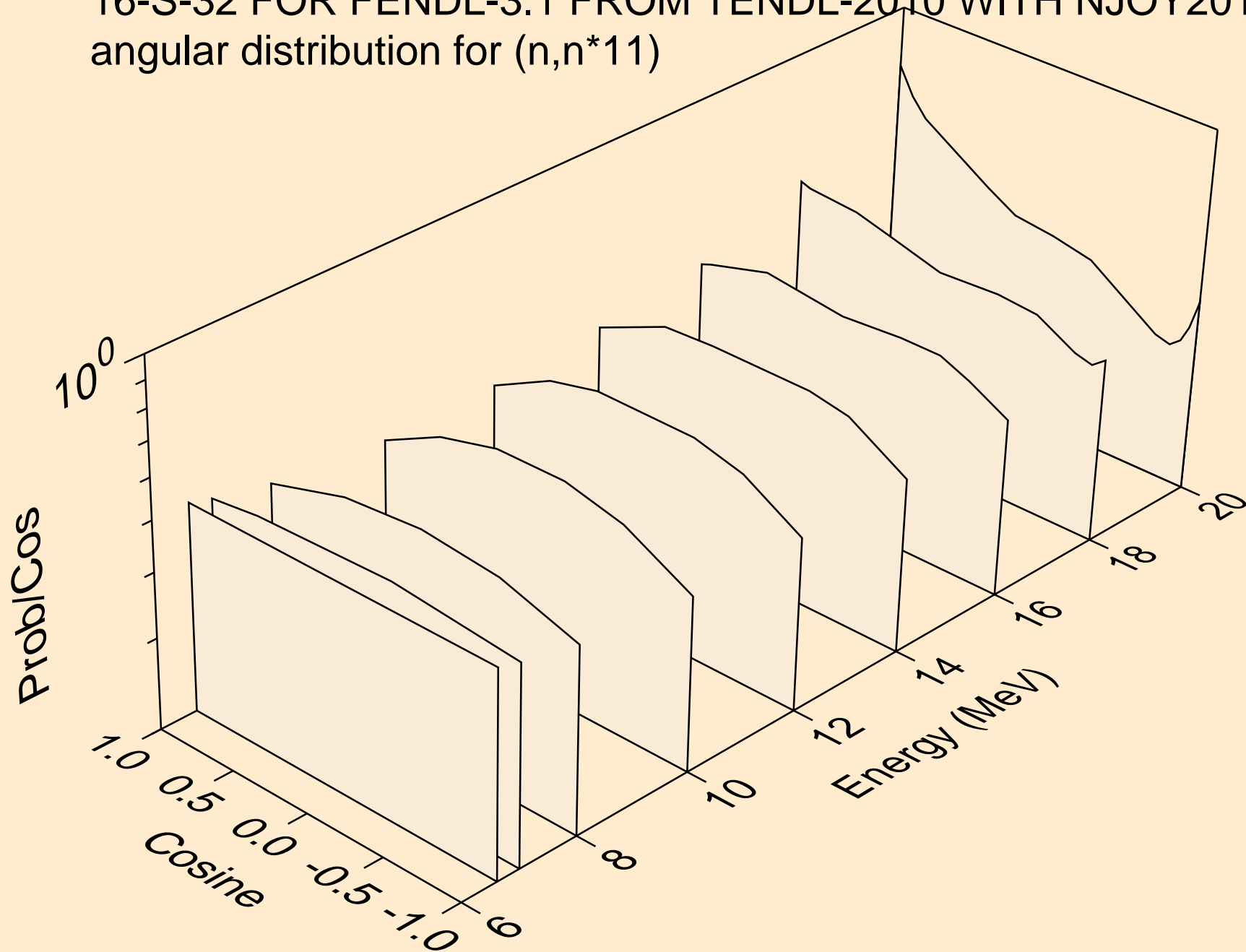

16-S-32 FOR FENDL-3.1 FROM TENDL-2010 WITH NJOY2012.50+
angular distribution for (n,n*12)

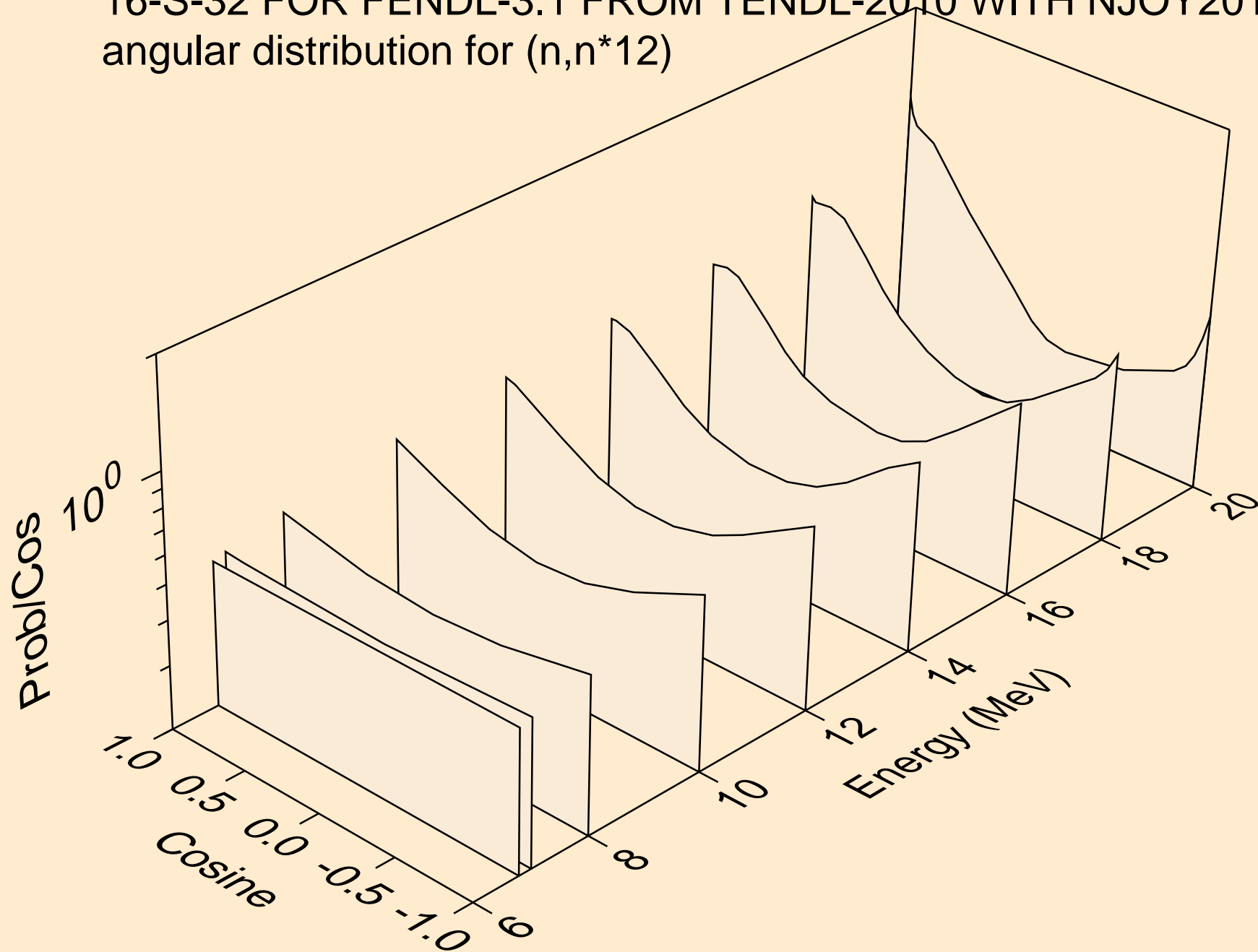

16-S-32 FOR FENDL-3.1 FROM TENDL-2010 WITH NJOY2012.50+
angular distribution for (n,n*13)

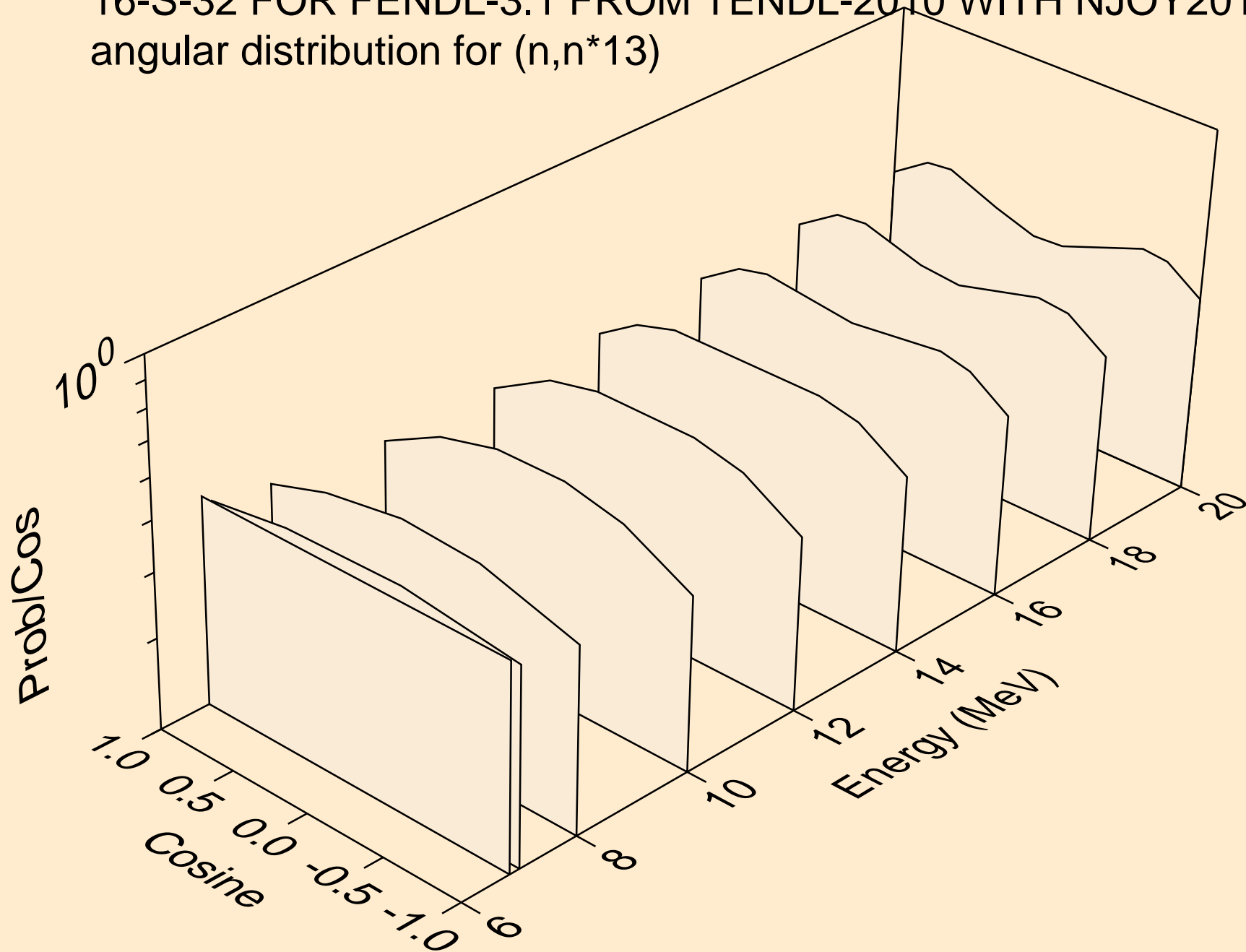

16-S-32 FOR FENDL-3.1 FROM TENDL-2010 WITH NJOY2012.50+
angular distribution for (n,n*14)

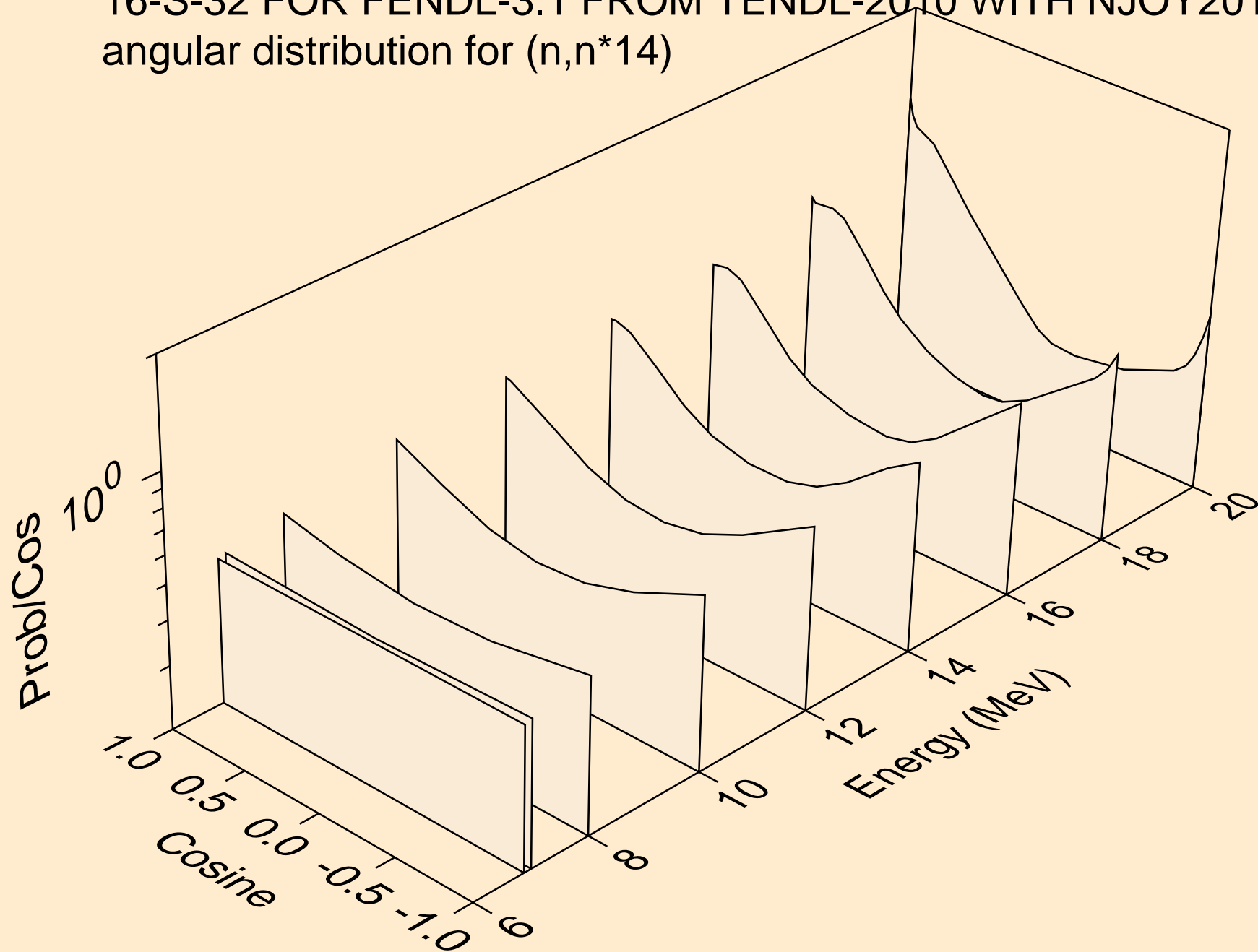

16-S-32 FOR FENDL-3.1 FROM TENDL-2010 WITH NJOY2012.50+
angular distribution for (n,n*15)

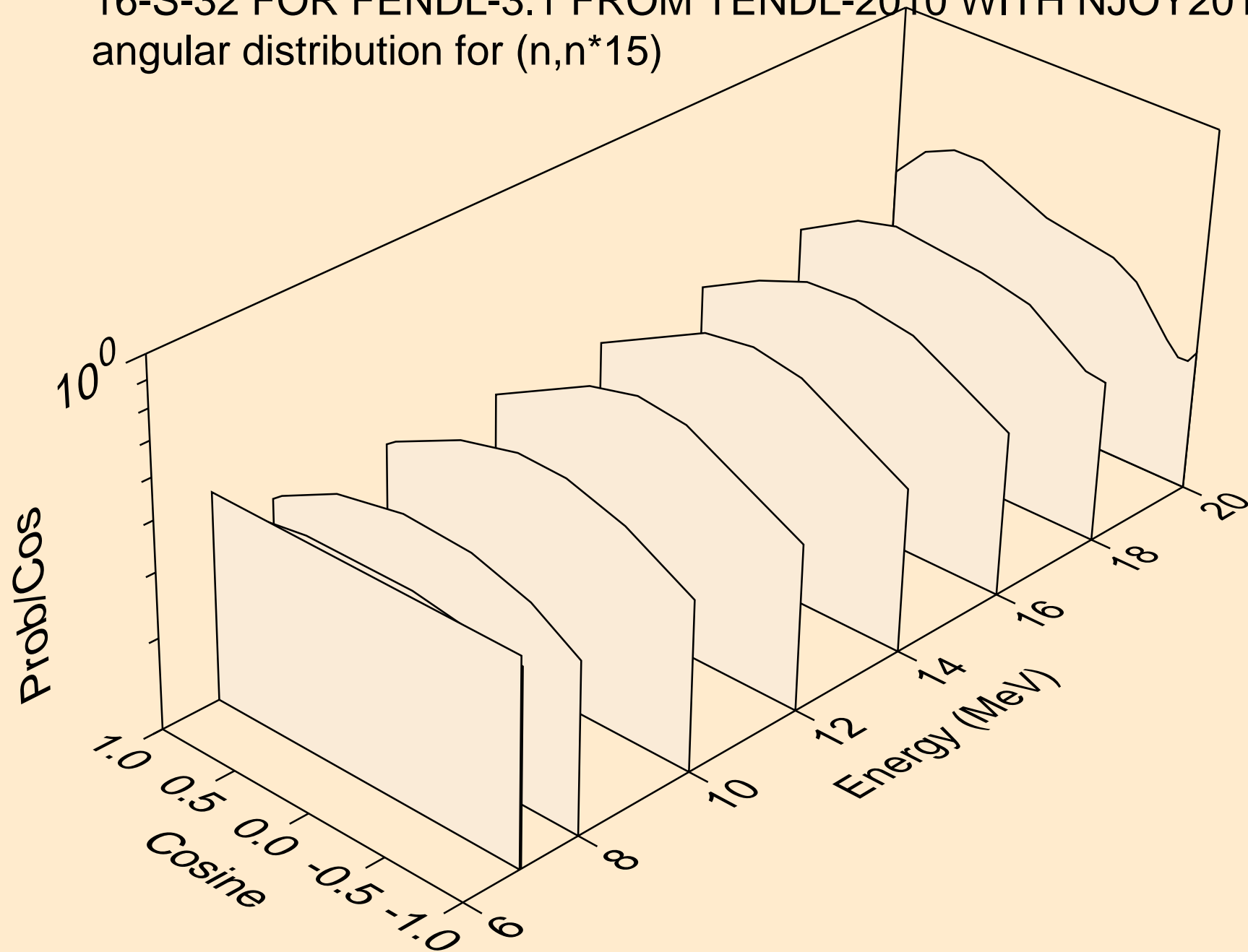

16-S-32 FOR FENDL-3.1 FROM TENDL-2010 WITH NJOY2012.50+
angular distribution for (n,n*16)

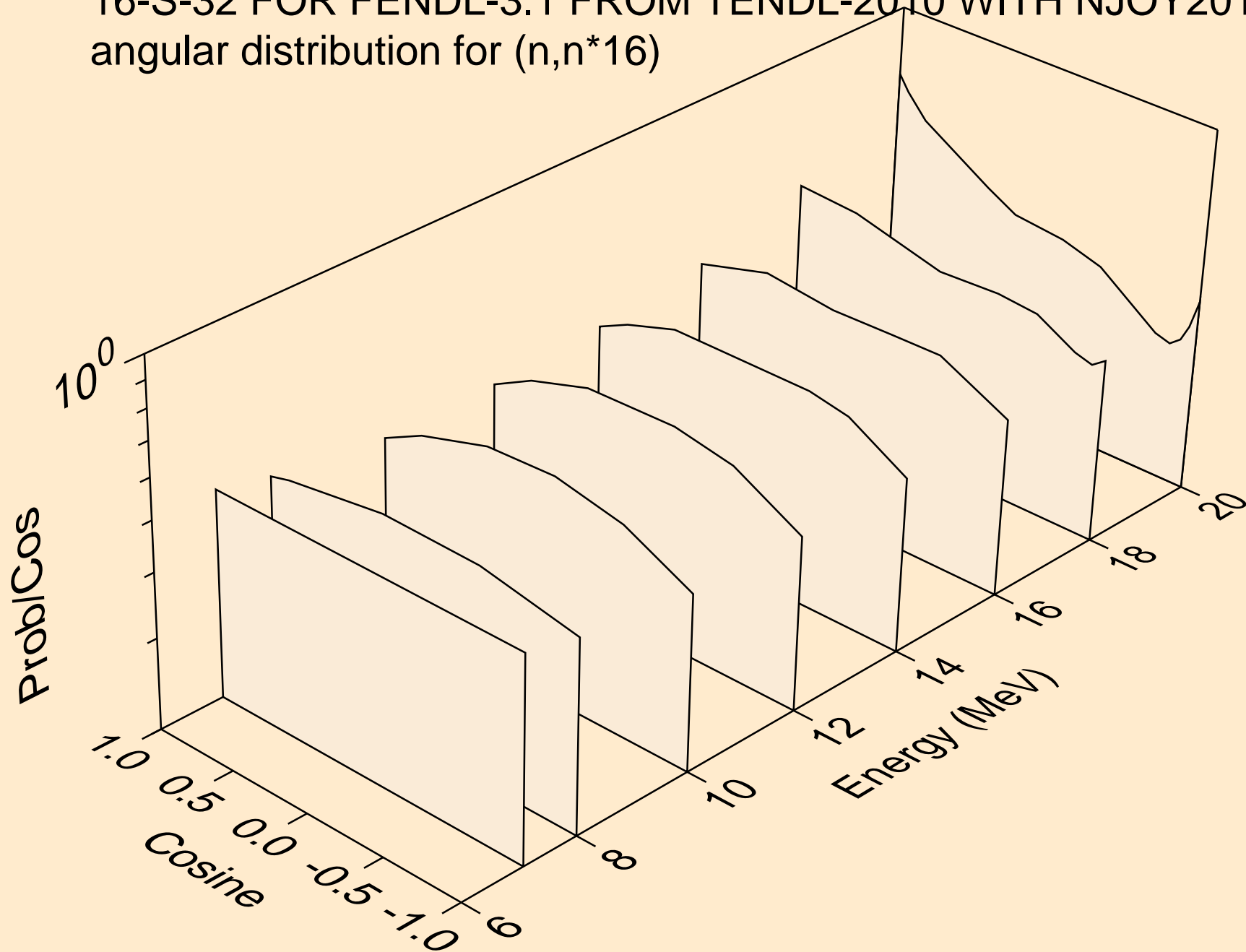

16-S-32 FOR FENDL-3.1 FROM TENDL-2010 WITH NJOY2012.50+
angular distribution for (n,n*17)

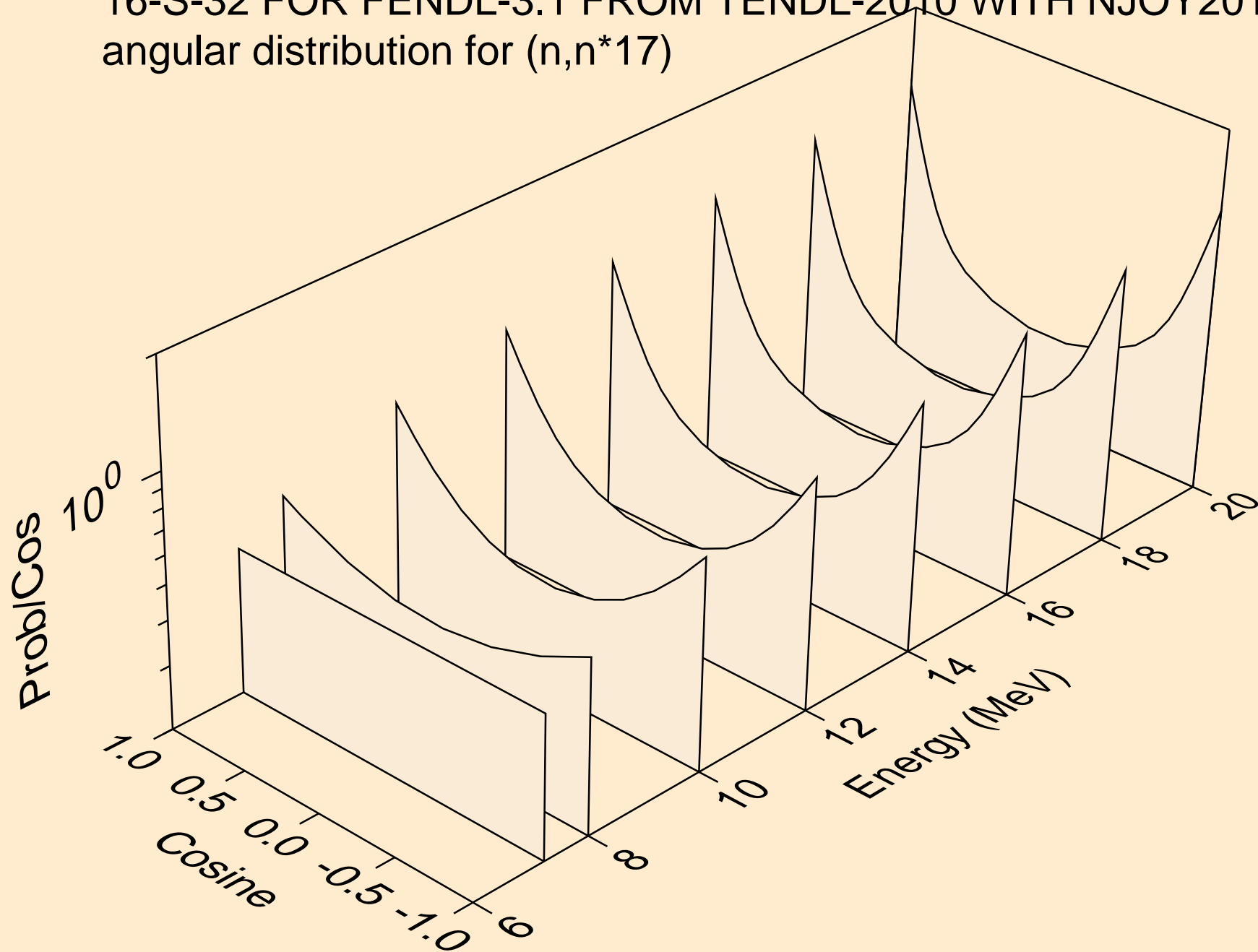

16-S-32 FOR FENDL-3.1 FROM TENDL-2010 WITH NJOY2012.50+
angular distribution for (n,n*18)

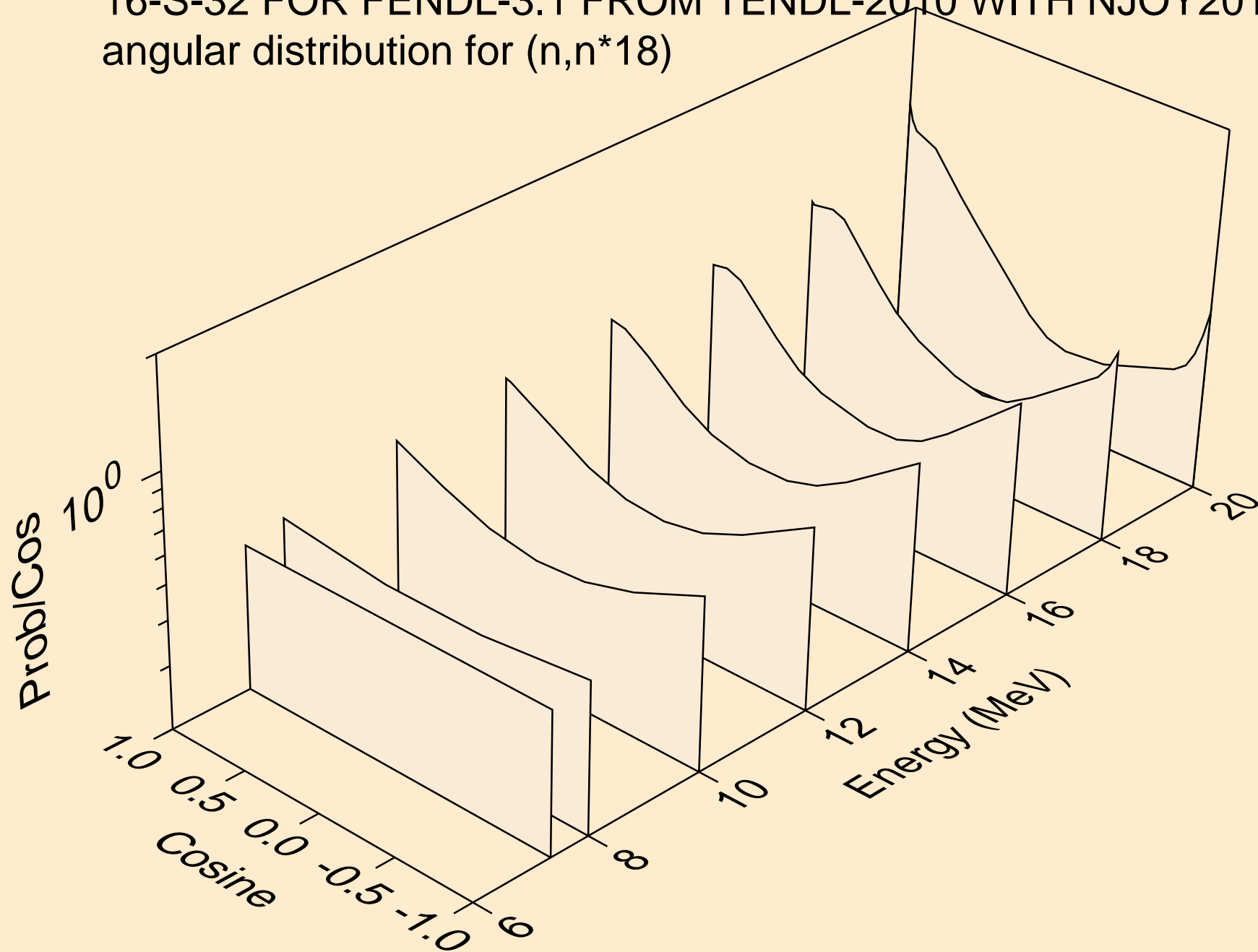

16-S-32 FOR FENDL-3.1 FROM TENDL-2010 WITH NJOY2012.50+
angular distribution for (n,n*19)

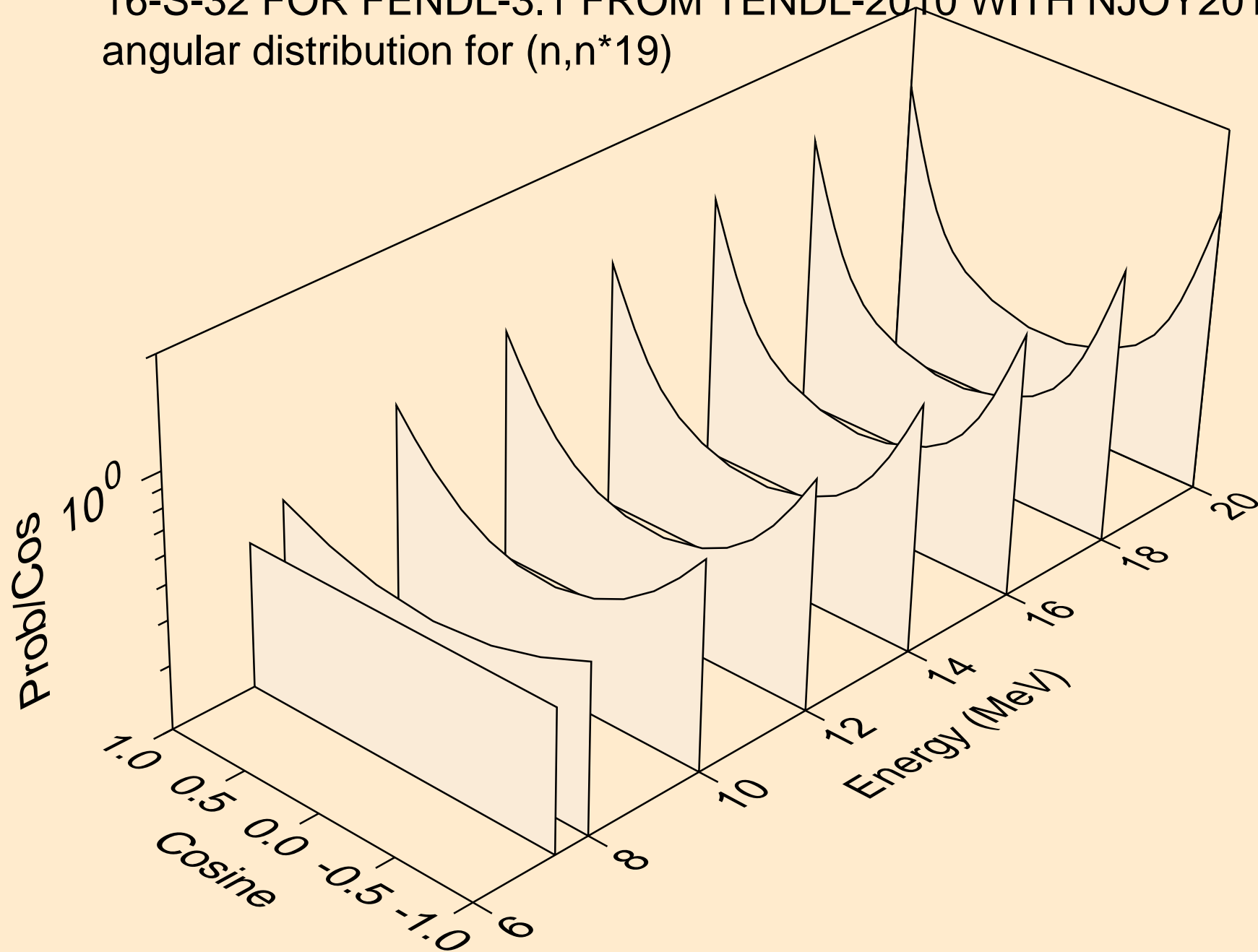

16-S-32 FOR FENDL-3.1 FROM TENDL-2010 WITH NJOY2012.50+
angular distribution for (n,n*20)

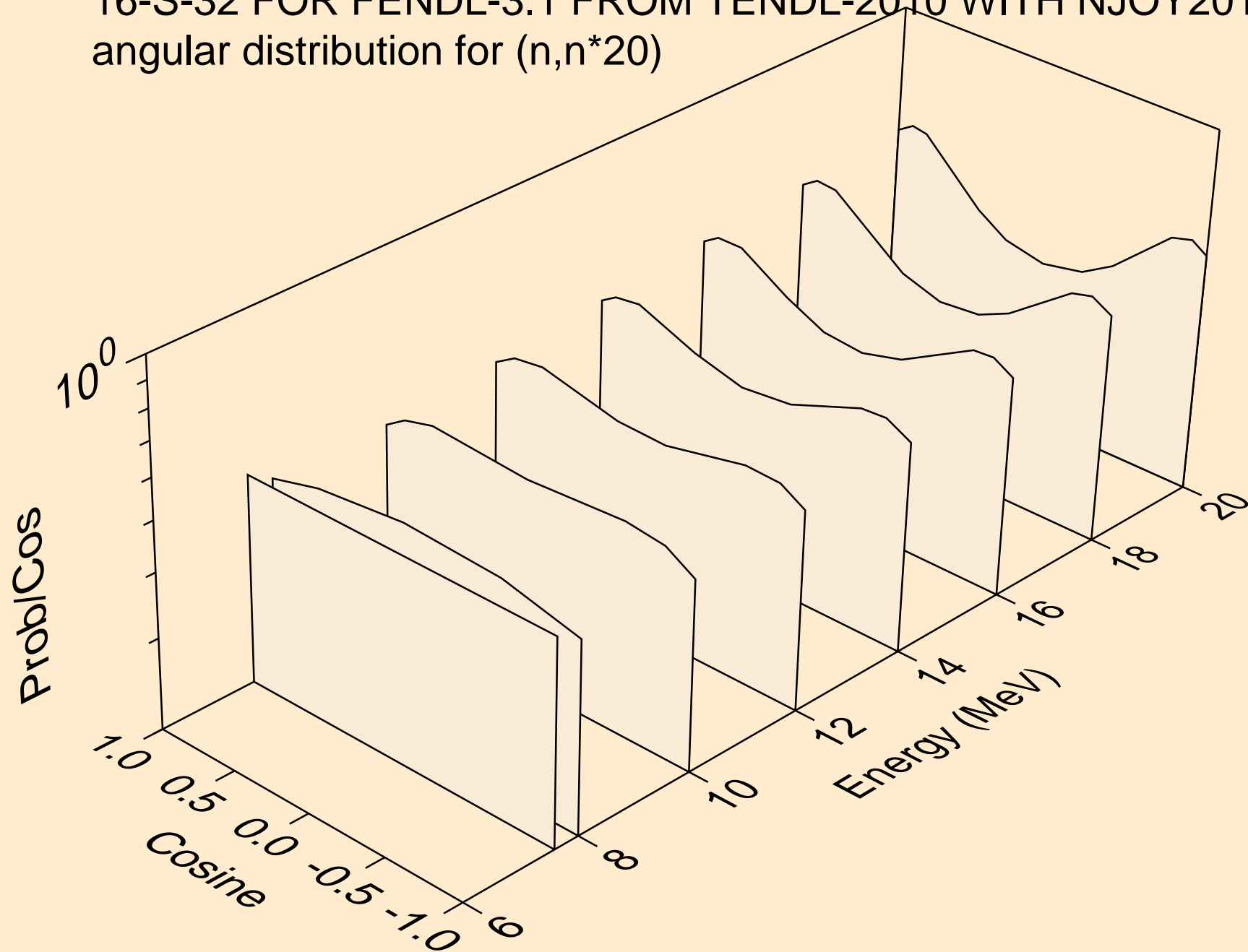

16-S-32 FOR FENDL-3.1 FROM TENDL-2010 WITH NJOY2012.50+
Neutron emission for (n,x)

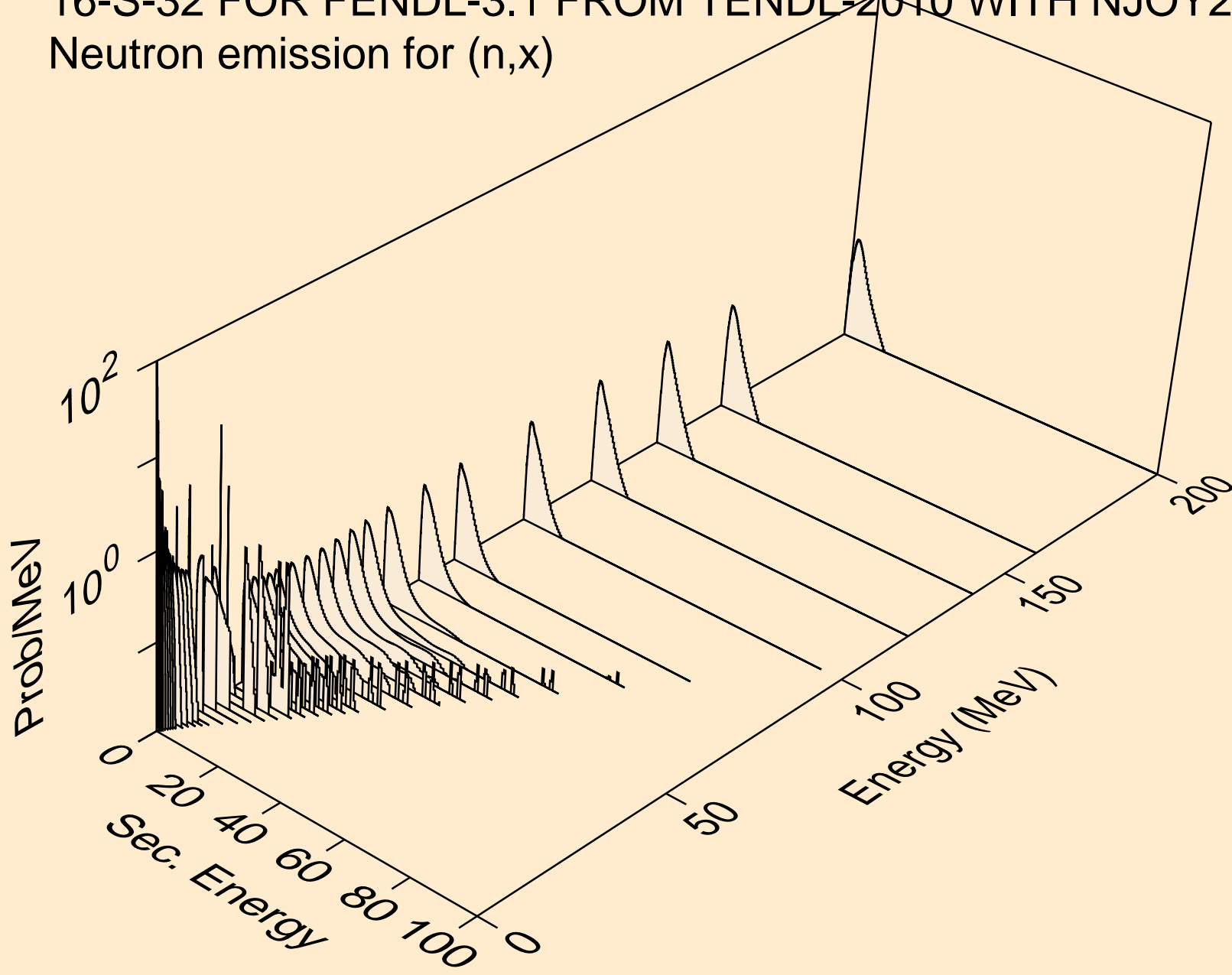

16-S-32 FOR FENDL-3.1 FROM TENDL-2010 WITH NJOY2012.50+
Neutron emission for (n,2n)

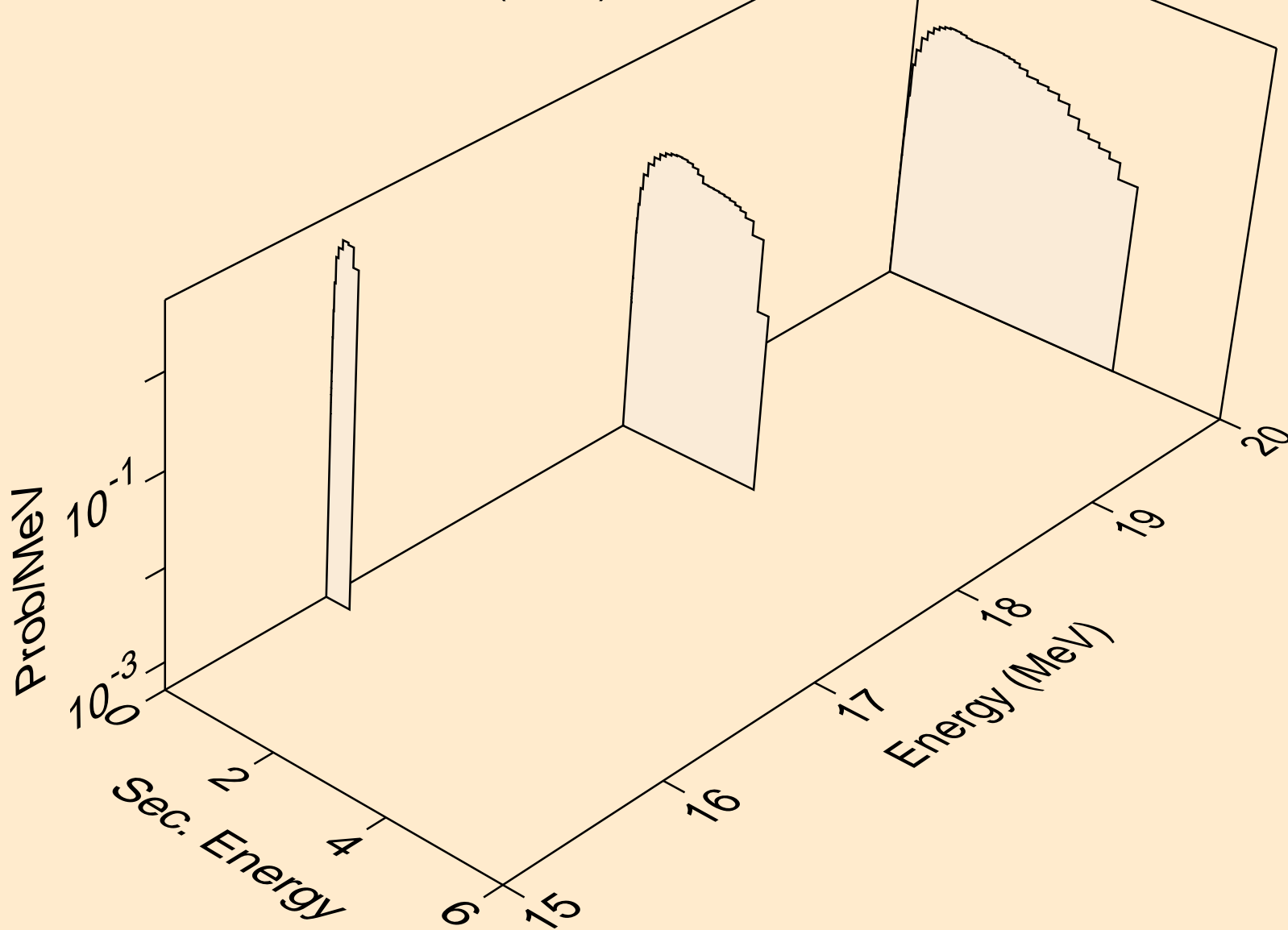

16-S-32 FOR FENDL-3.1 FROM TENDL-2010 WITH NJOY2012.50+
Neutron emission for (n,n*)a

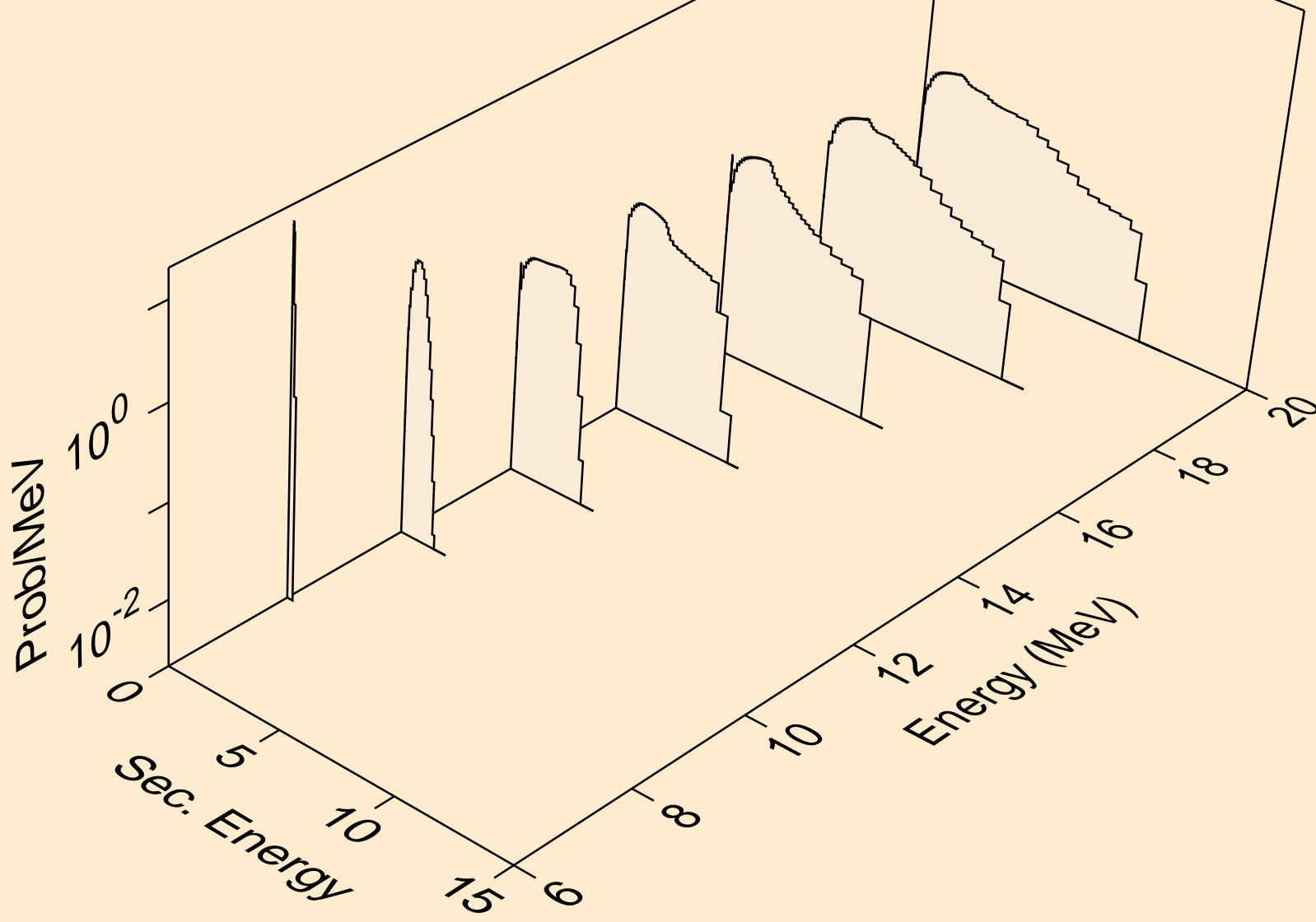

16-S-32 FOR FENDL-3.1 FROM TENDL-2010 WITH NJOY2012.50+
Neutron emission for (n,n*)p

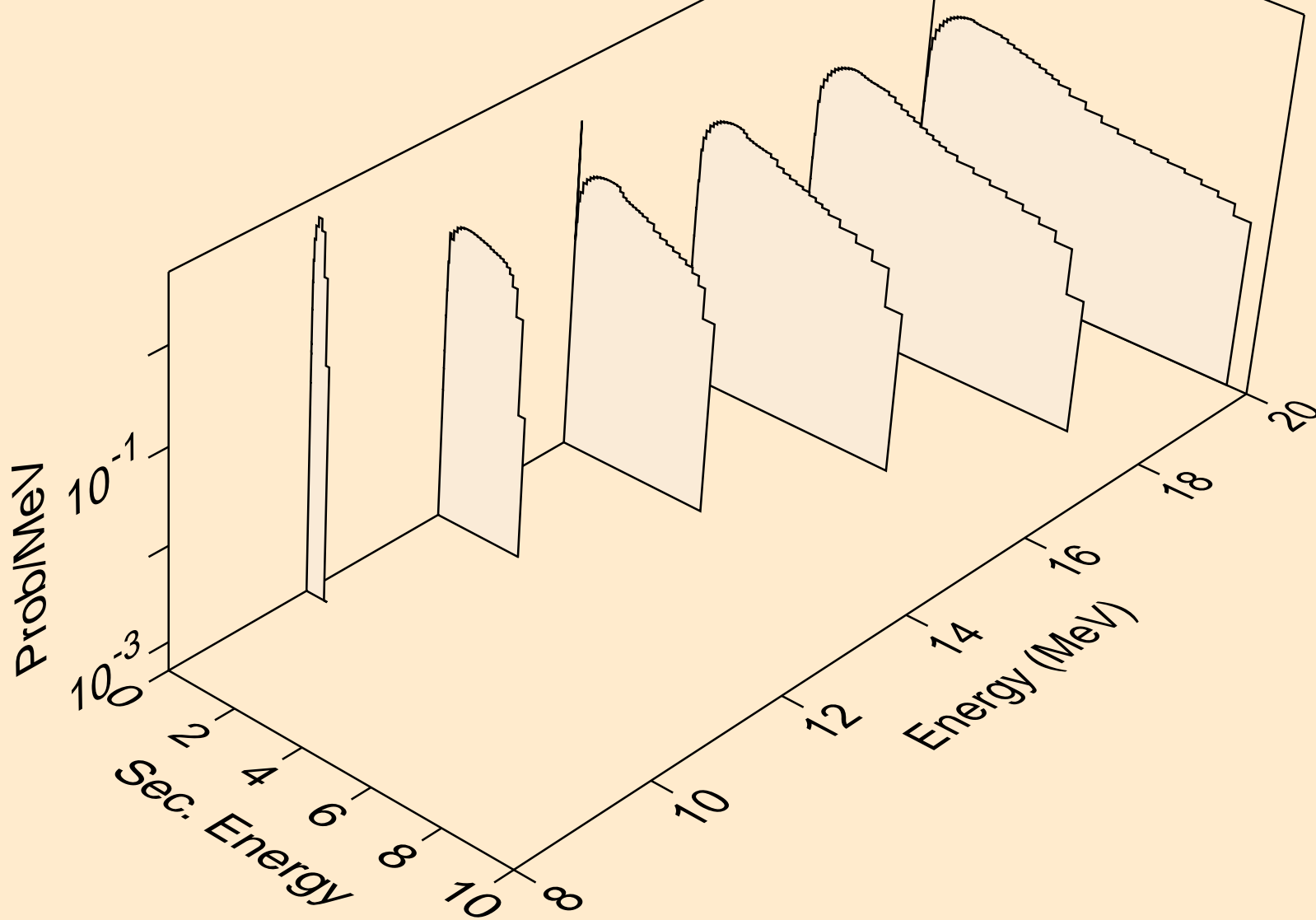

16-S-32 FOR FENDL-3.1 FROM TENDL-2010 WITH NJOY2012.50+
Neutron emission for (n,2np)

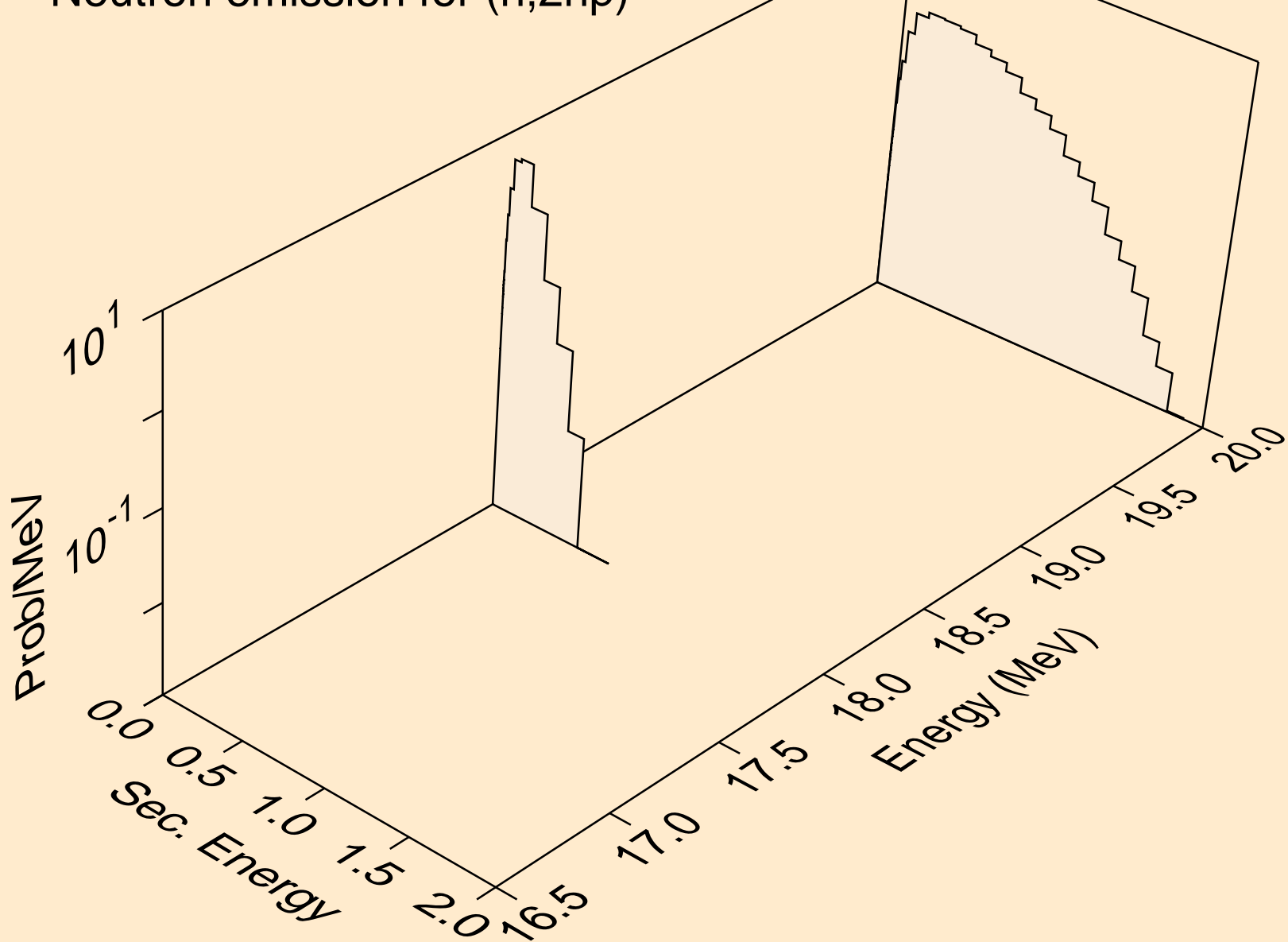

16-S-32 FOR FENDL-3.1 FROM TENDL-2010 WITH NJOY2012.50+
Neutron emission for (n,n*c)

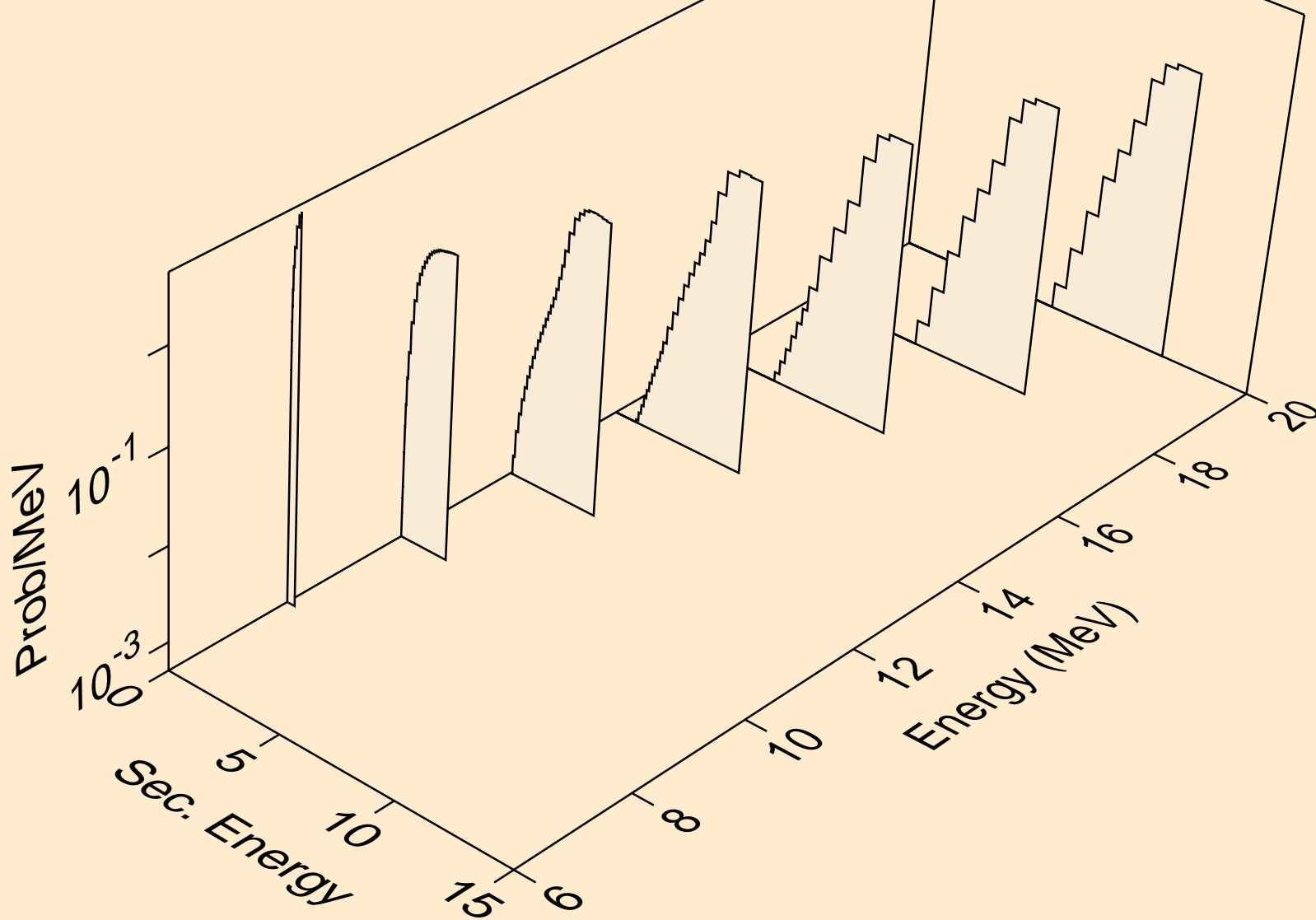

16-S-32 FOR FENDL-3.1 FROM TENDL-2010 WITH NJOY2012.50+
Photon emission for (n,x)

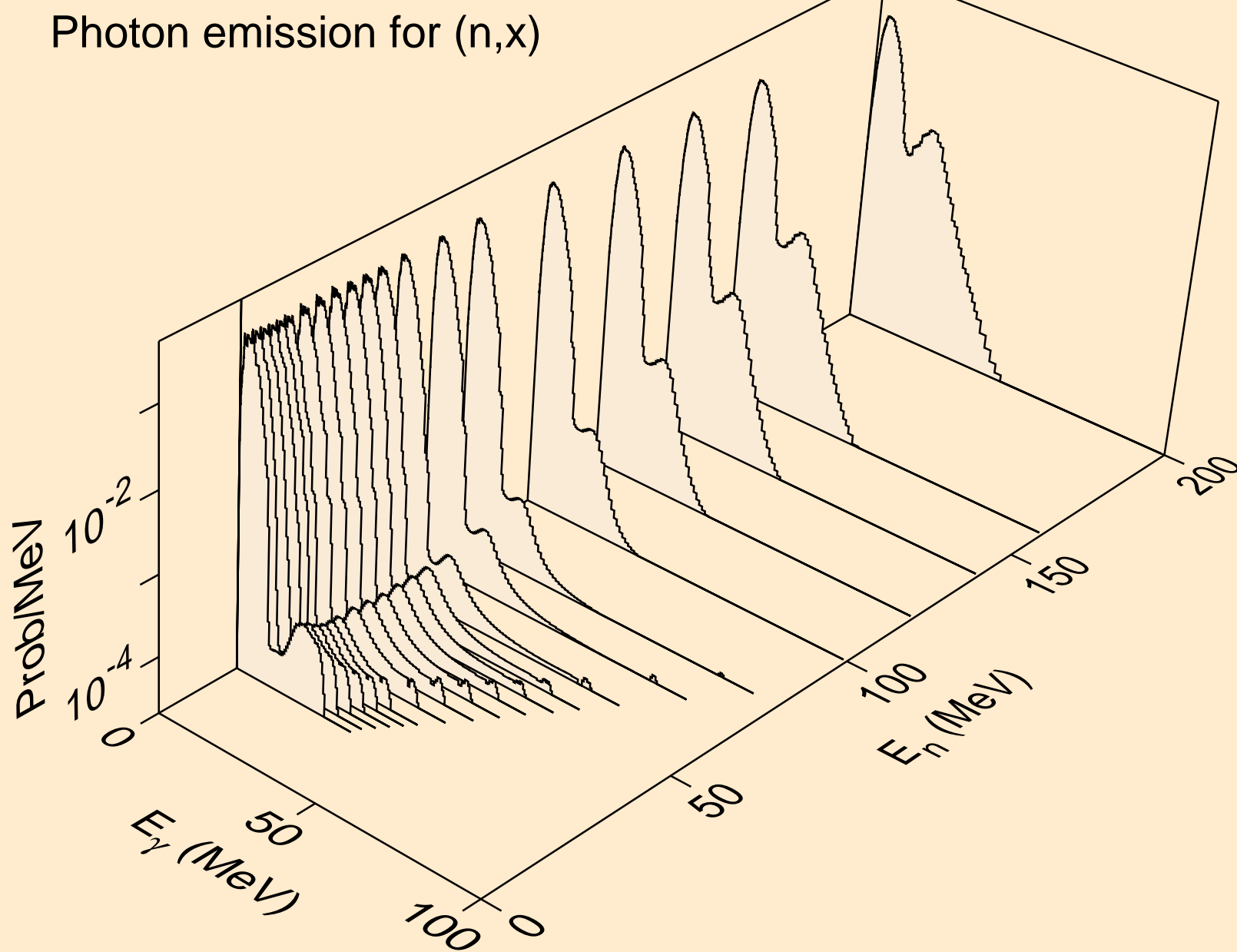

16-S-32 FOR FENDL-3.1 FROM TENDL-2010 WITH NJOY2012.50+
Photon emission for (n,2n)

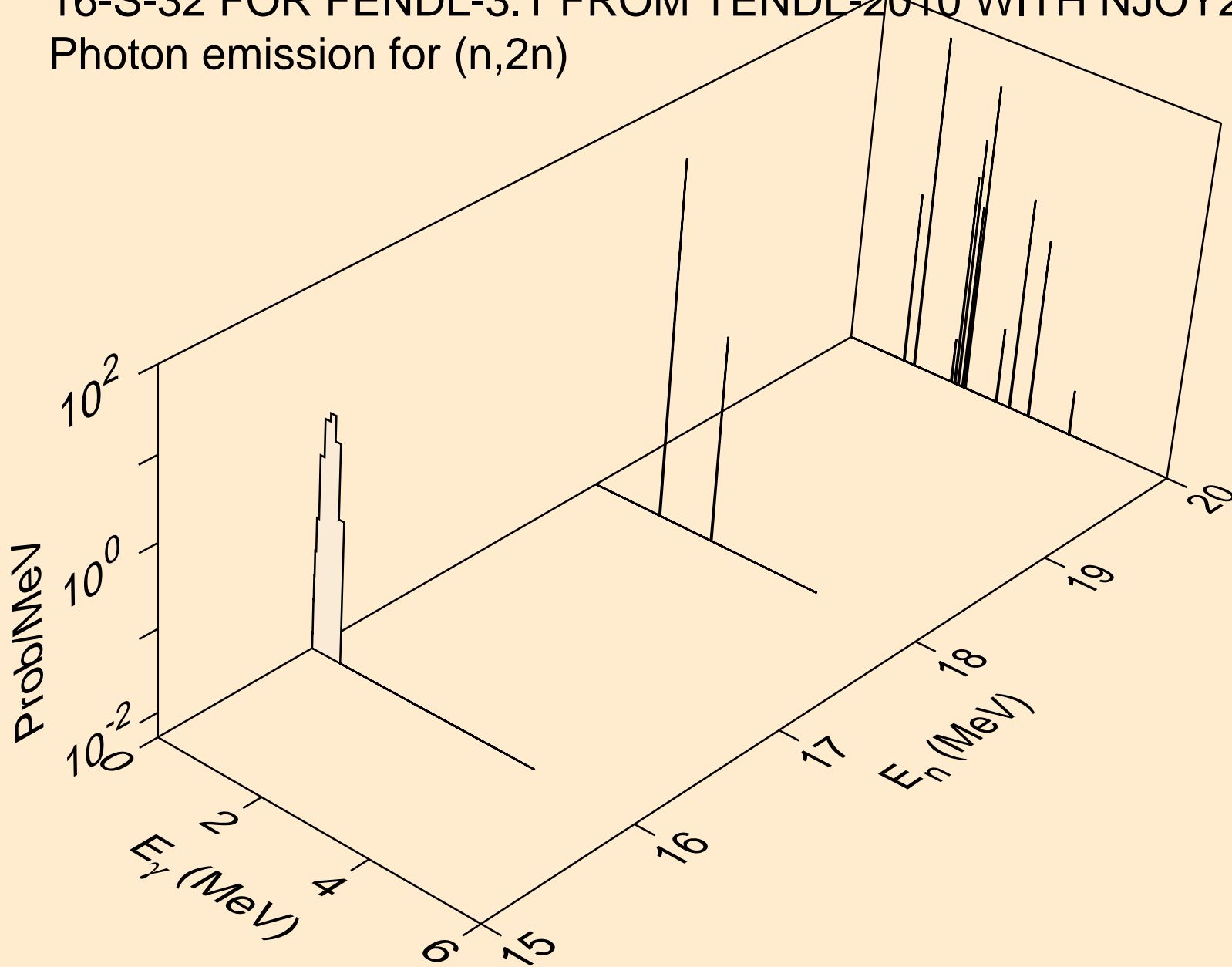

16-S-32 FOR FENDL-3.1 FROM TENDL-2010 WITH NJOY2012.50+
Photon emission for (n,n*)a

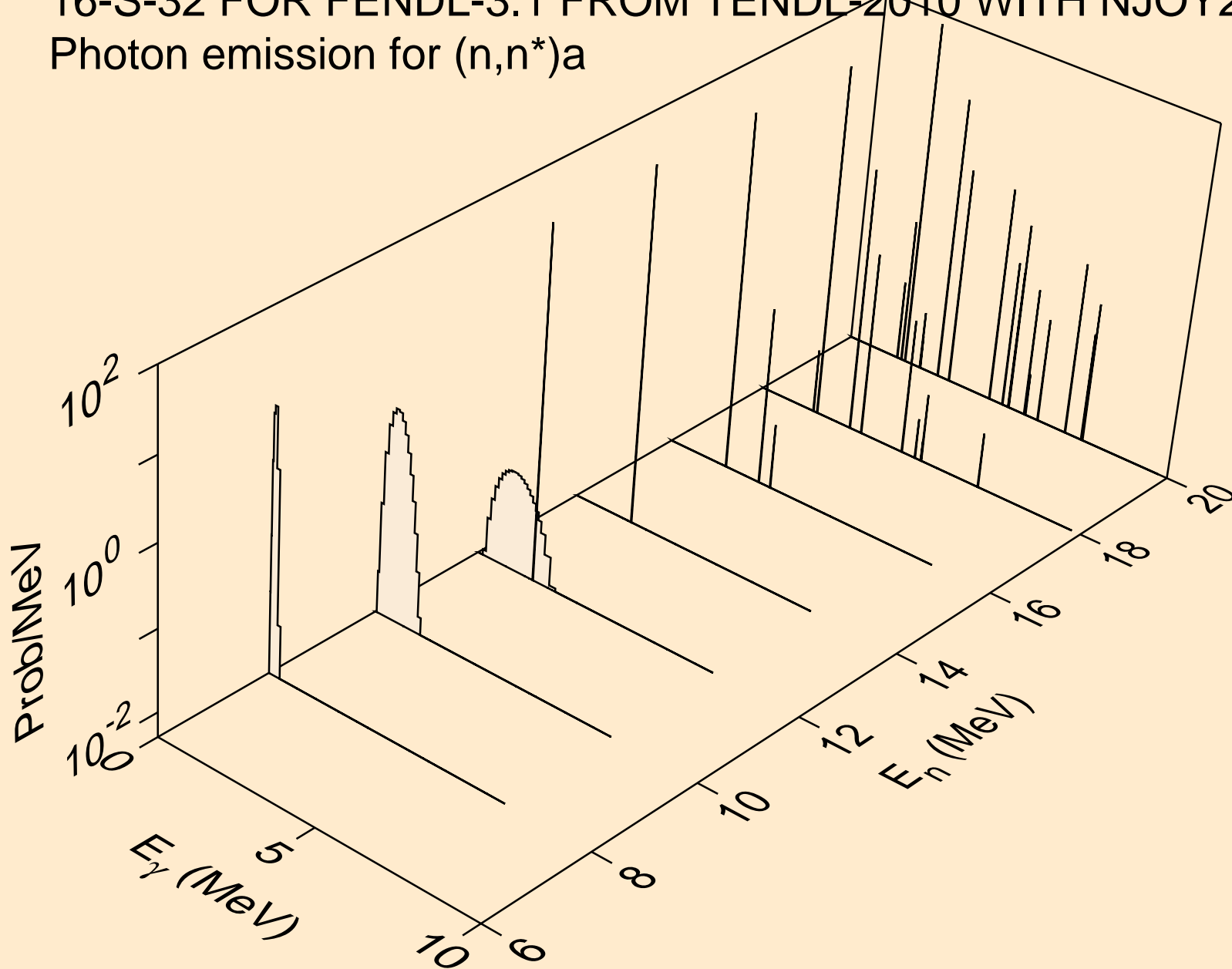

16-S-32 FOR FENDL-3.1 FROM TENDL-2010 WITH NJOY2012.50+
Photon emission for (n,n*)p

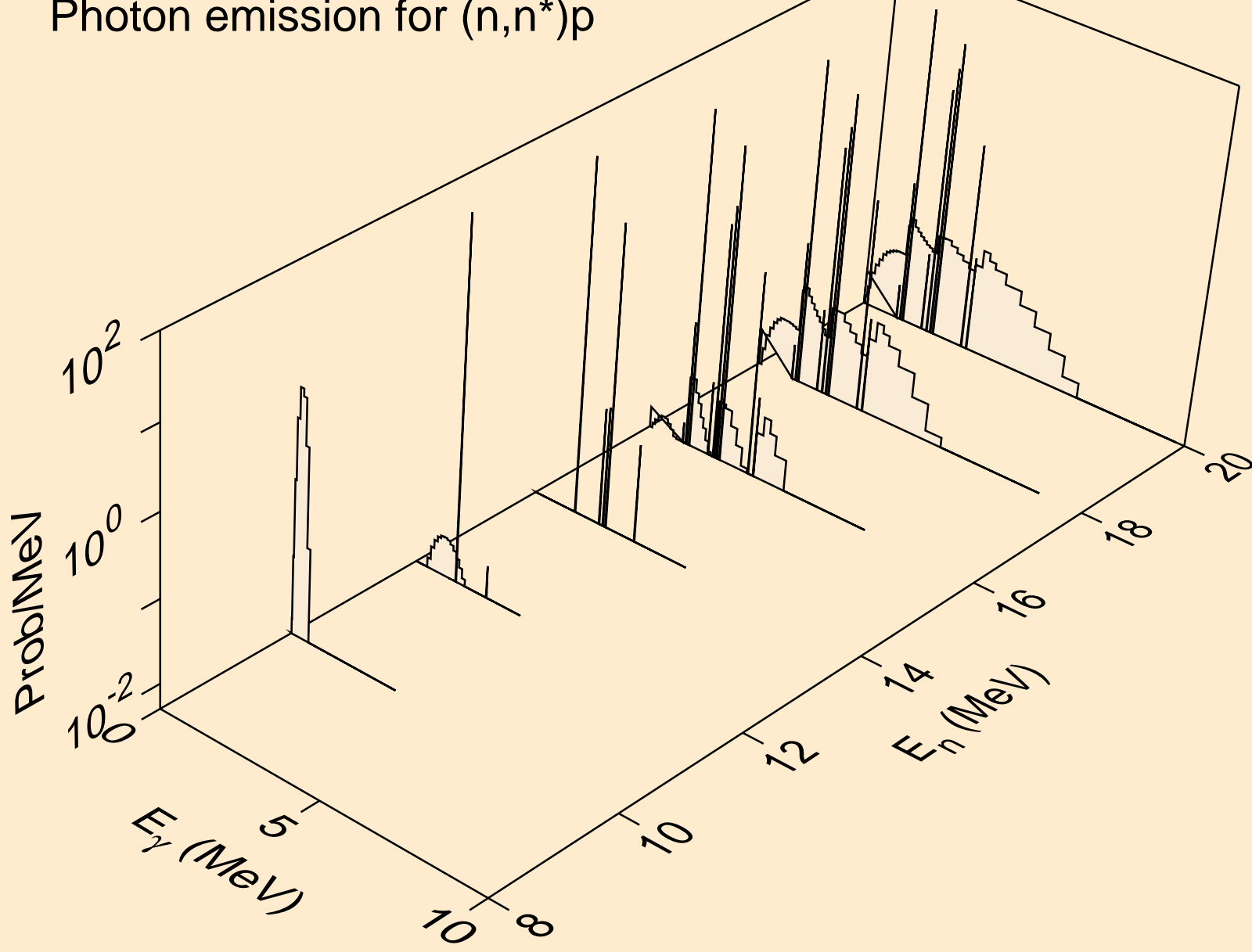

16-S-32 FOR FENDL-3.1 FROM TENDL-2010 WITH NJOY2012.50+
Photon emission for (n,2np)

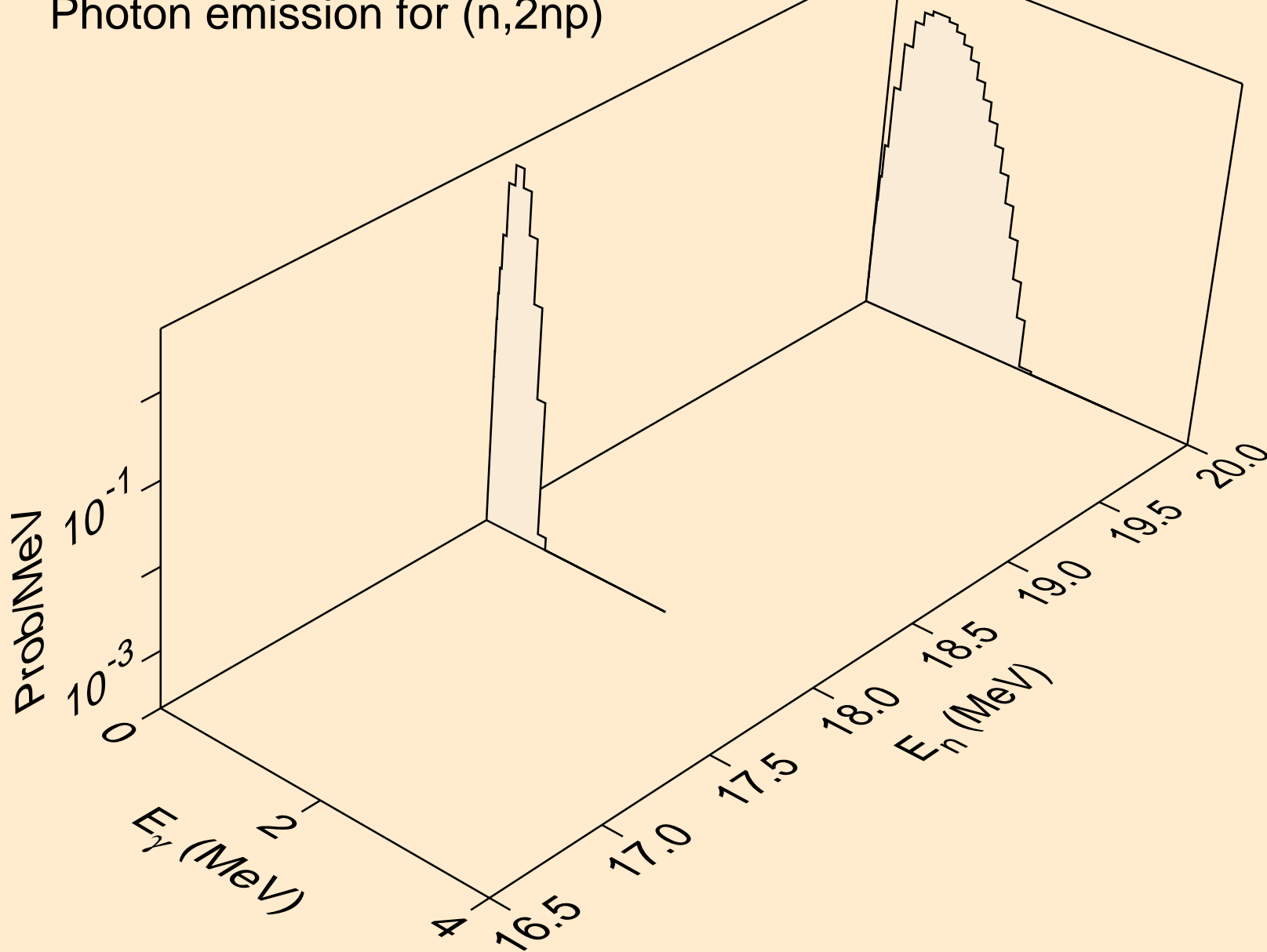

16-S-32 FOR FENDL-3.1 FROM TENDL-2010 WITH NJOY2012.50+
Photon emission for (n,n*c)

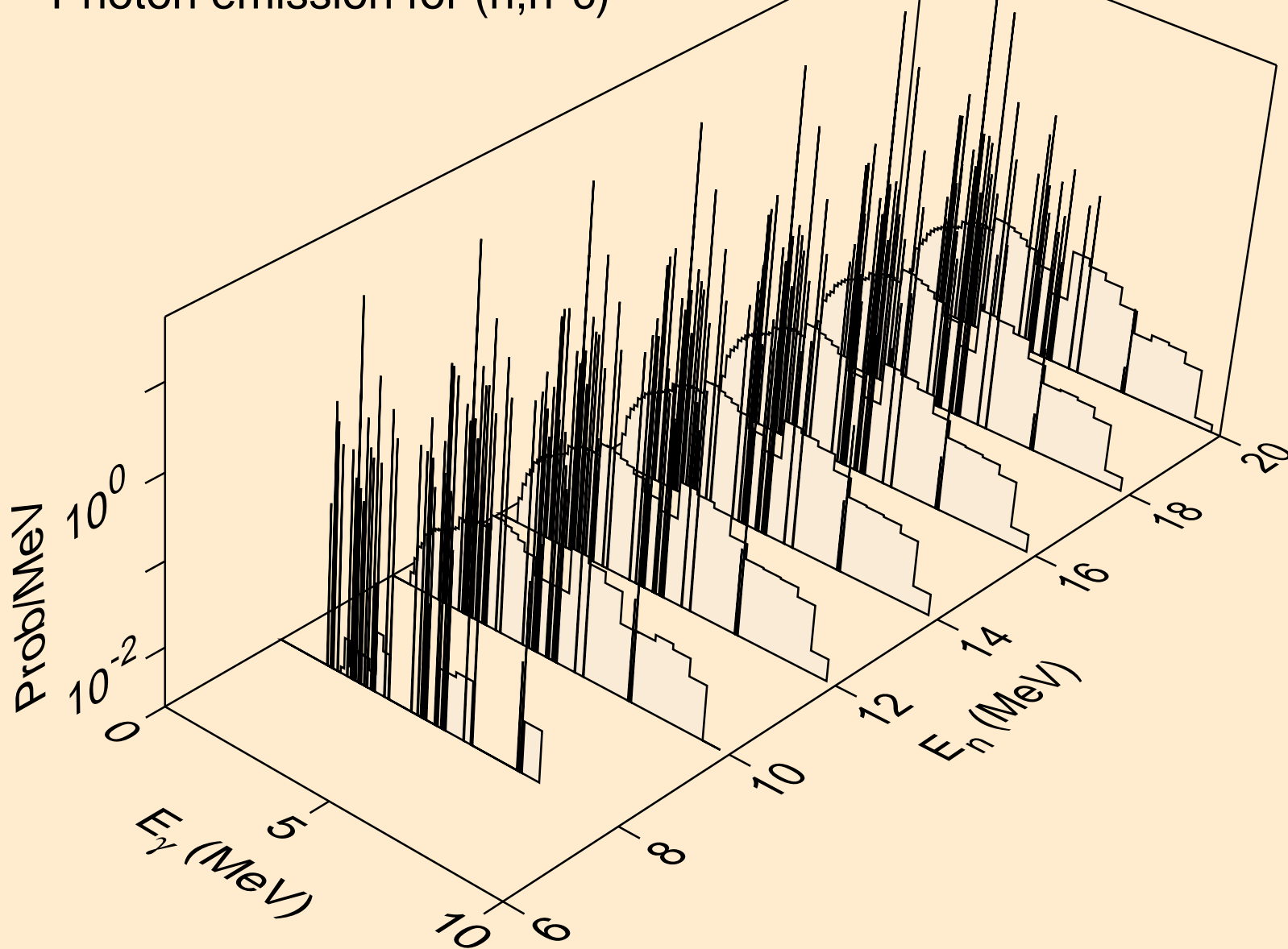

16-S-32 FOR FENDL-3.1 FROM TENDL-2010 WITH NJOY2012.50+
Photon emission for (n,gma)

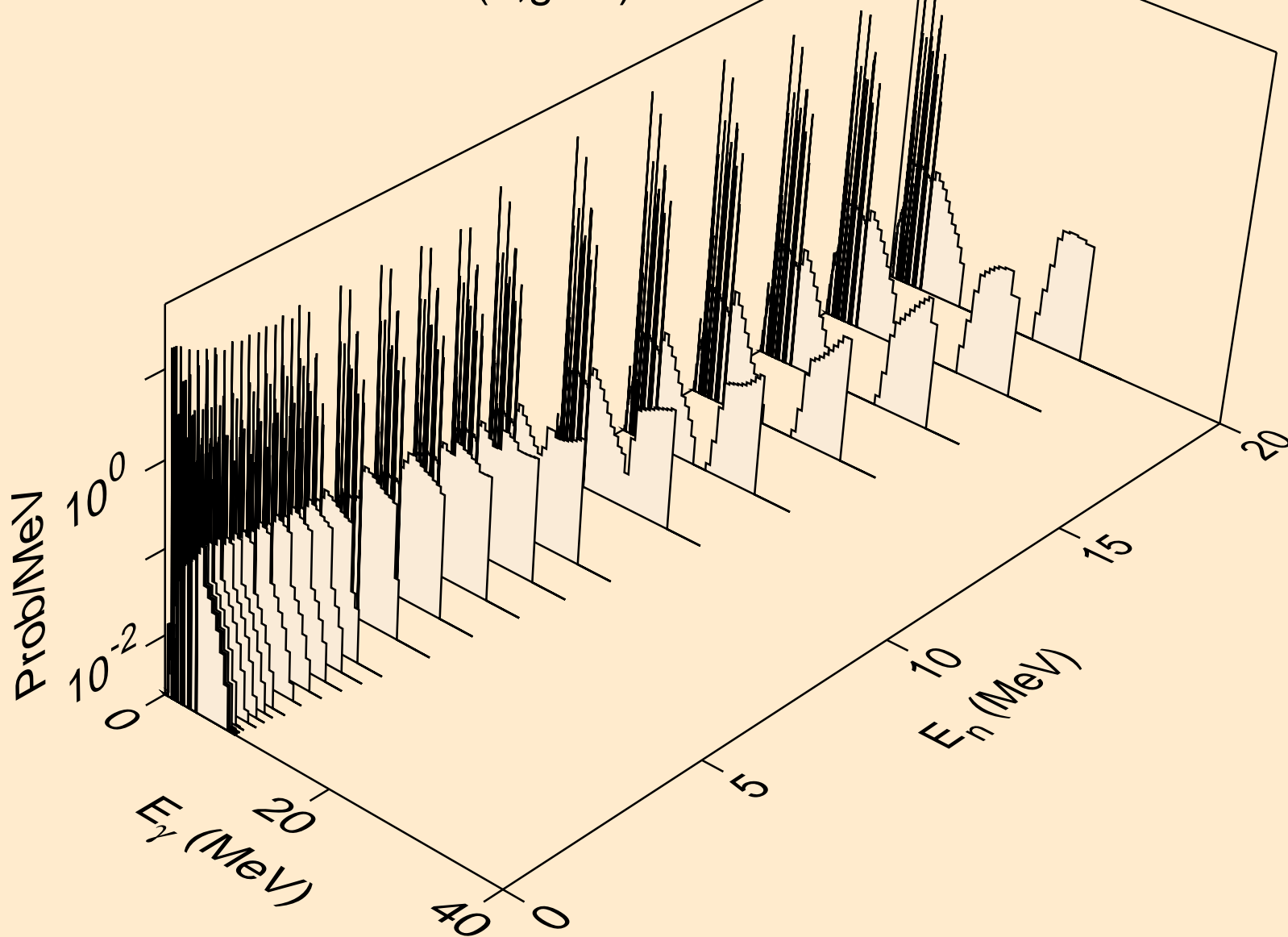

16-S-32 FOR FENDL-3.1 FROM TENDL-2010 WITH NJOY2012.50+
Photon emission for (n,2a)

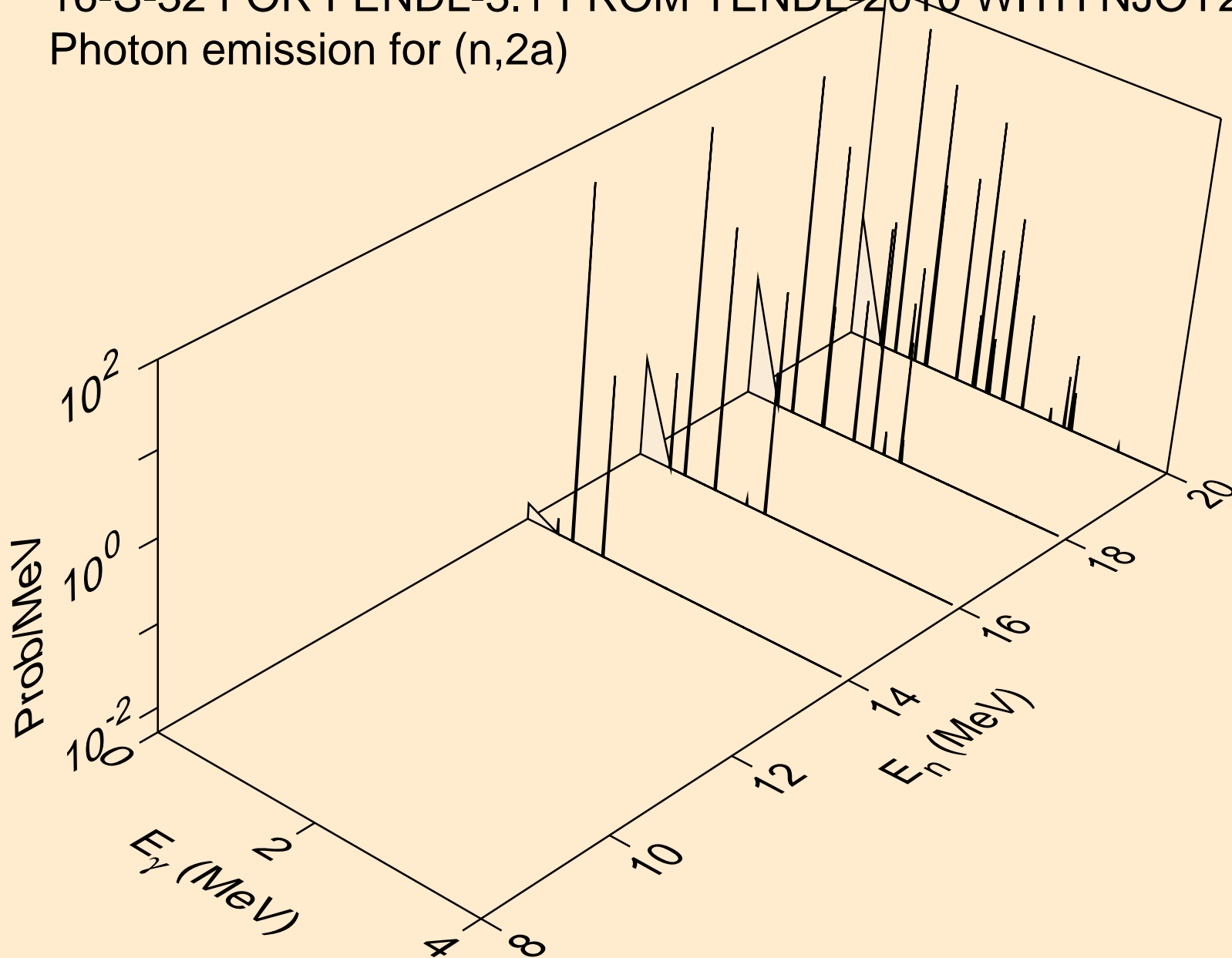

16-S-32 FOR FENDL-3.1 FROM TENDL-2010 WITH NJOY2012.50+
Photon emission for (n,2p)

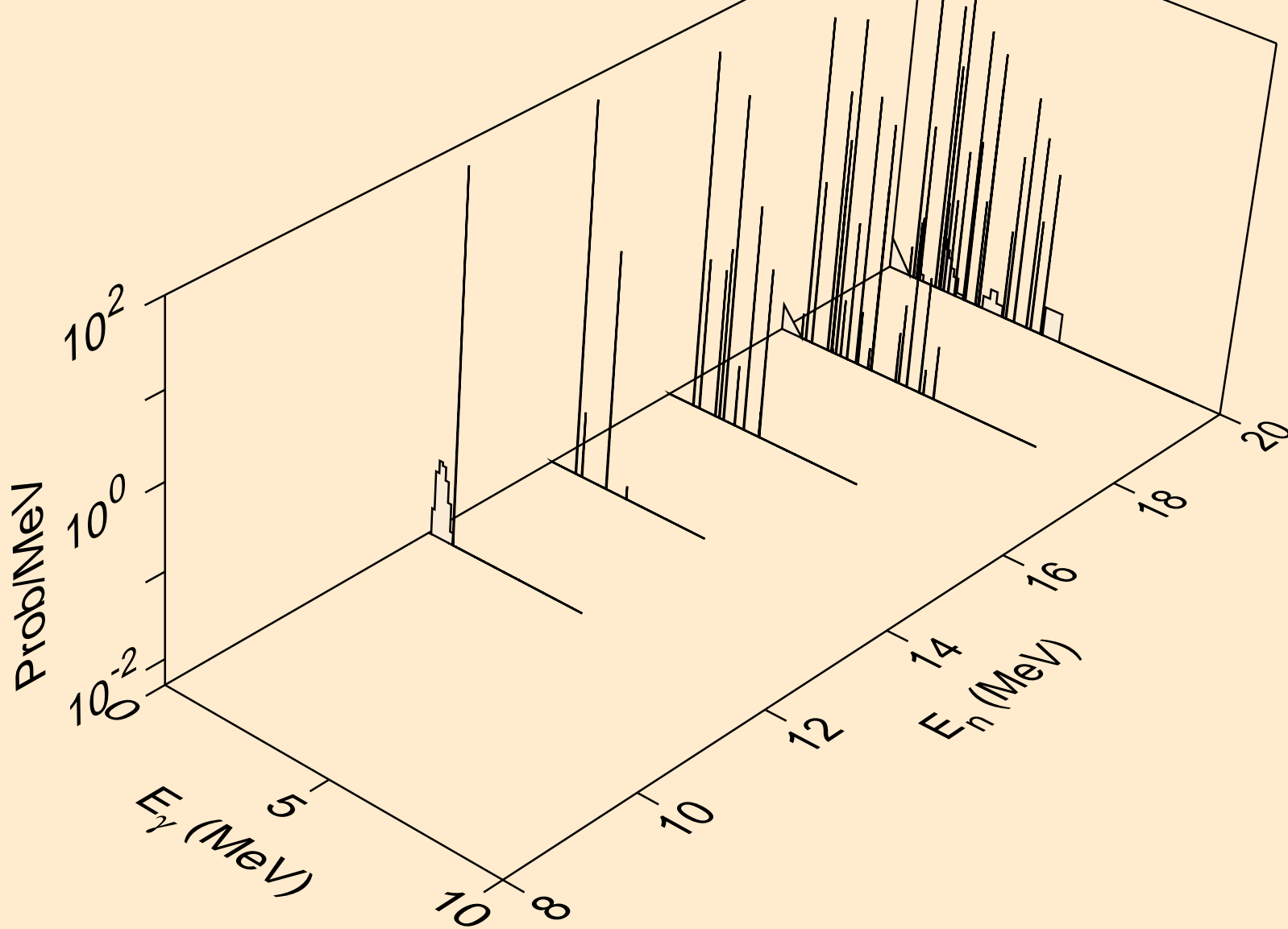

16-S-32 FOR FENDL-3.1 FROM TENDL-2010 WITH NJOY2012.50+
Photon emission for (n,pa)

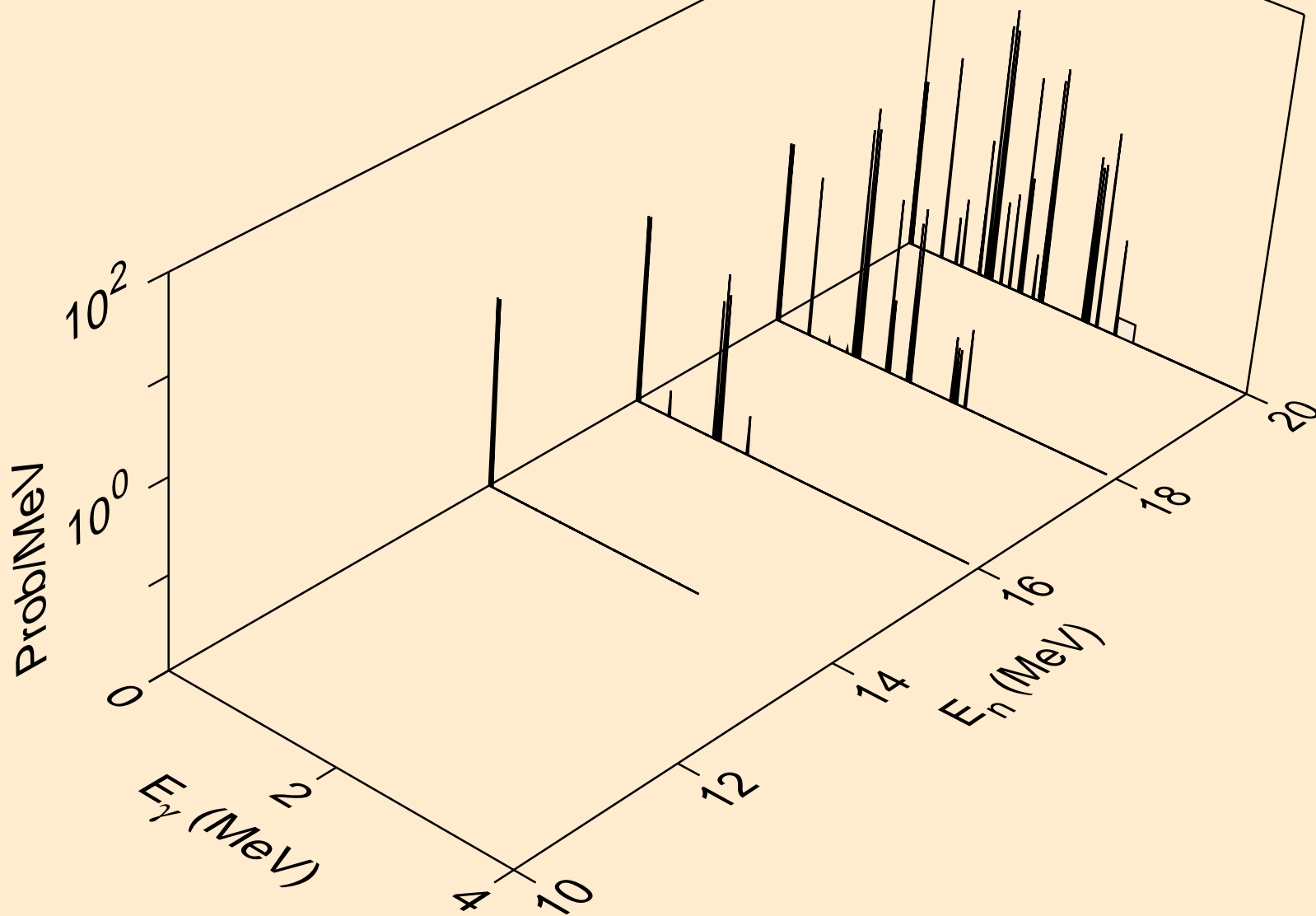

16-S-32 FOR FENDL-3.1 FROM TENDL-2010 WITH NJOY2012.50+
Photon emission for (n,pd)

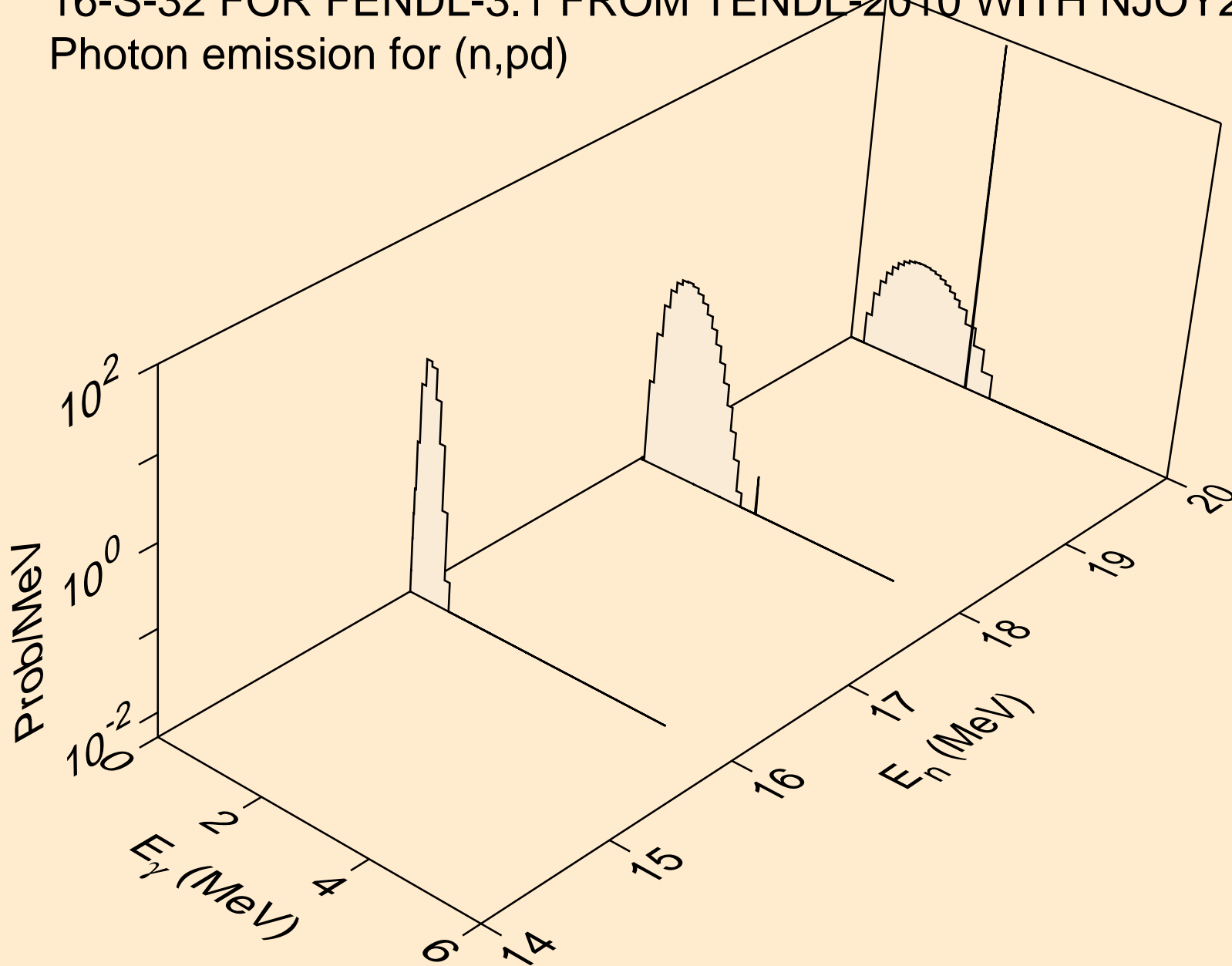

16-S-32 FOR FENDL-3.1 FROM TENDL-2010 WITH NJOY2012.50+
Photon emission for (n,p*c)

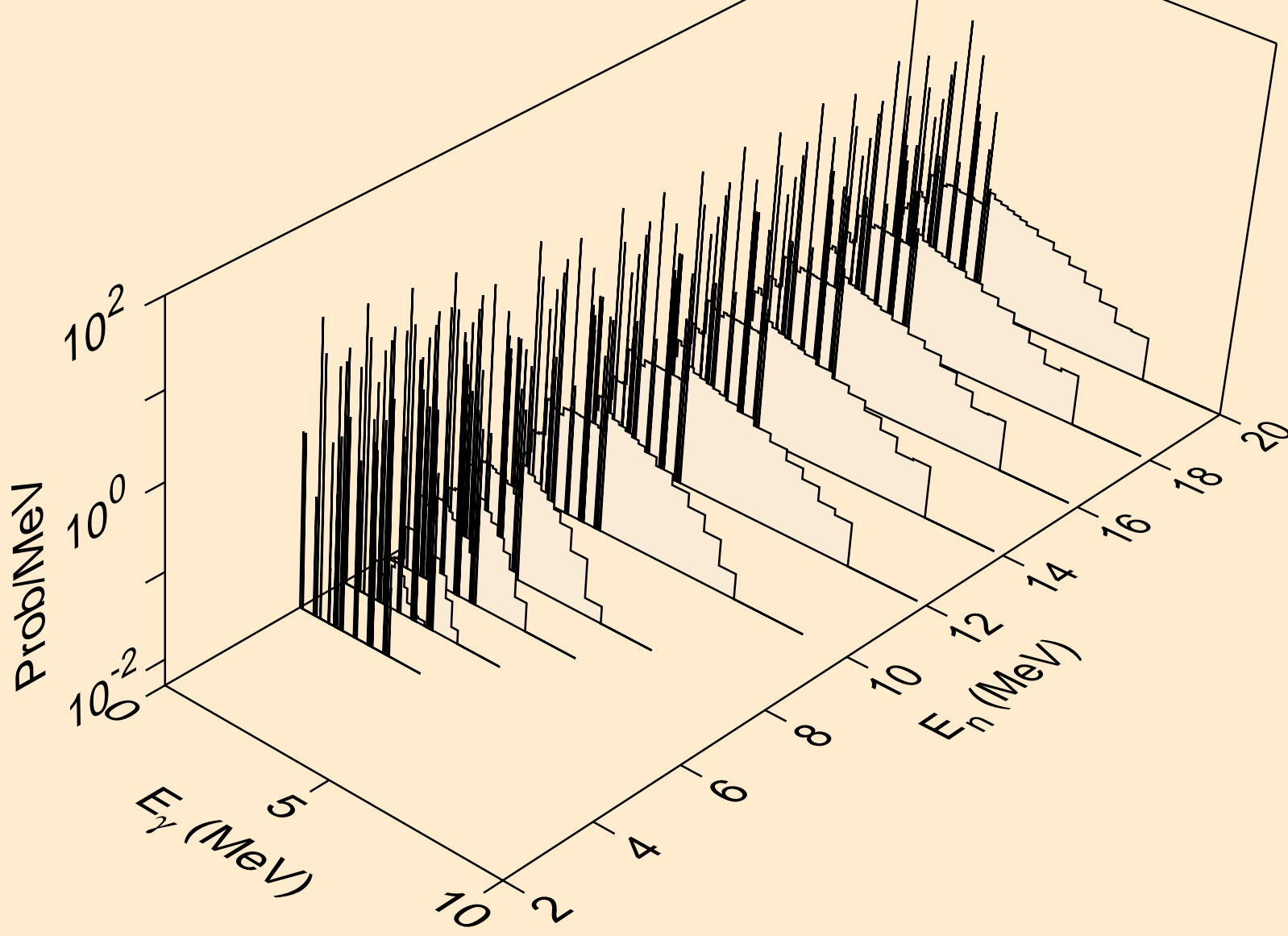

16-S-32 FOR FENDL-3.1 FROM TENDL-2010 WITH NJOY2012.50+
Photon emission for (n,a*c)

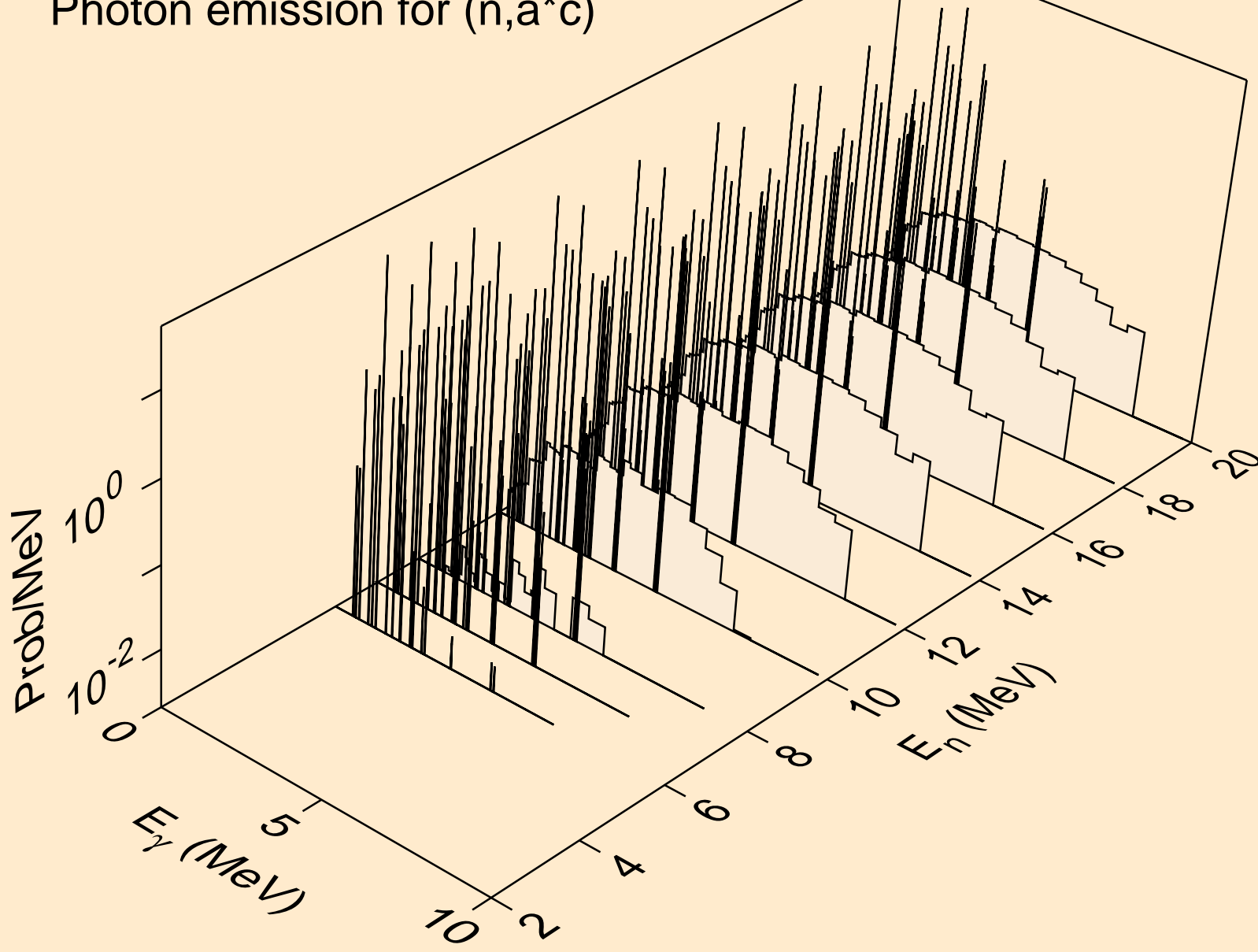

16-S-32 FOR FENDL-3.1 FROM TENDL-2010 WITH NJOY2012.50+
thermal capture photon spectrum

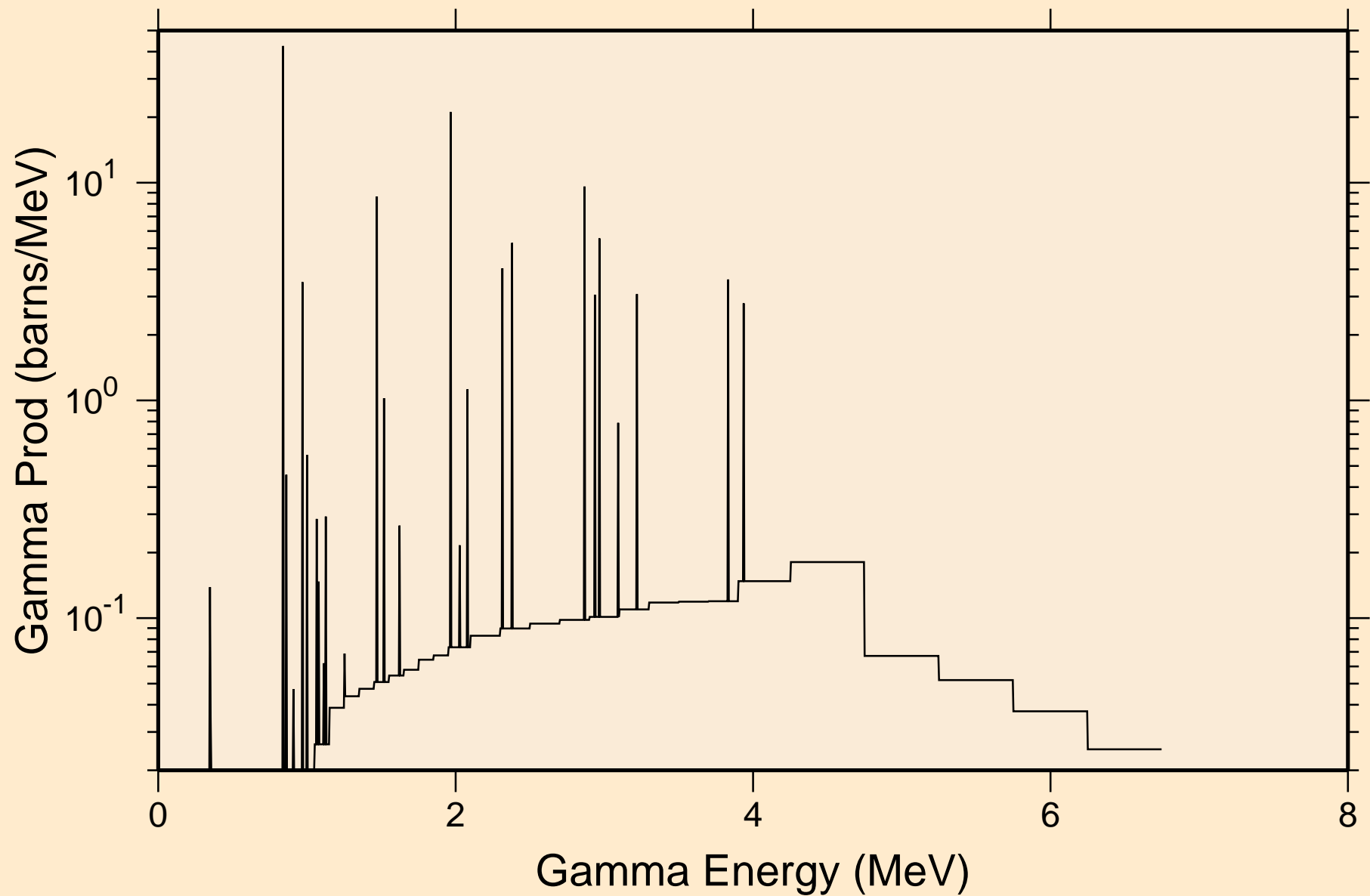

16-S-32 FOR FENDL-3.1 FROM TENDL-2010 WITH NJOY2012.50+
14 MeV photon spectrum

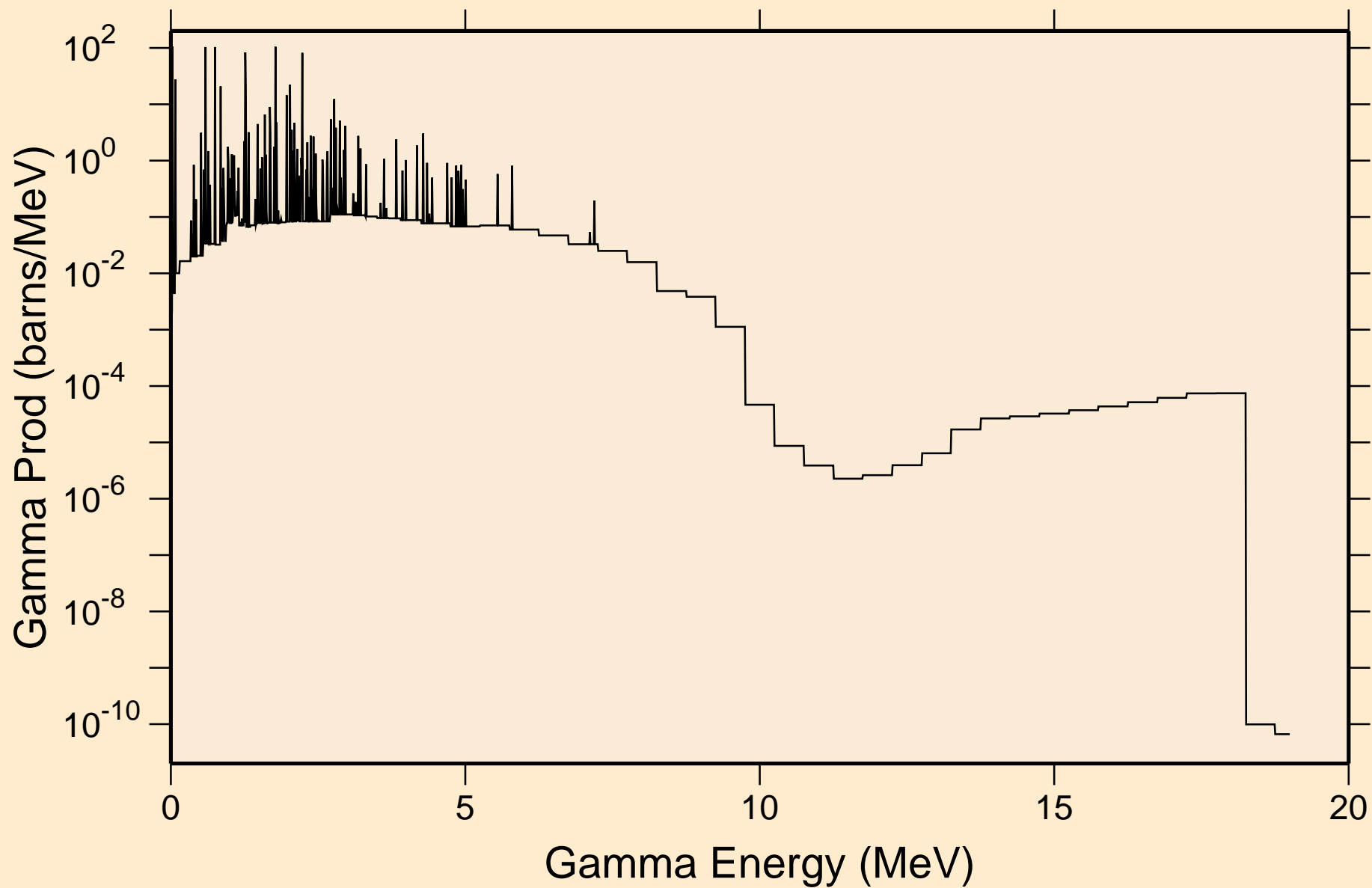

16-S-32 FOR FENDL-3.1 FROM TENDL-2010 WITH NJOY2012.50+

Particle heating contributions

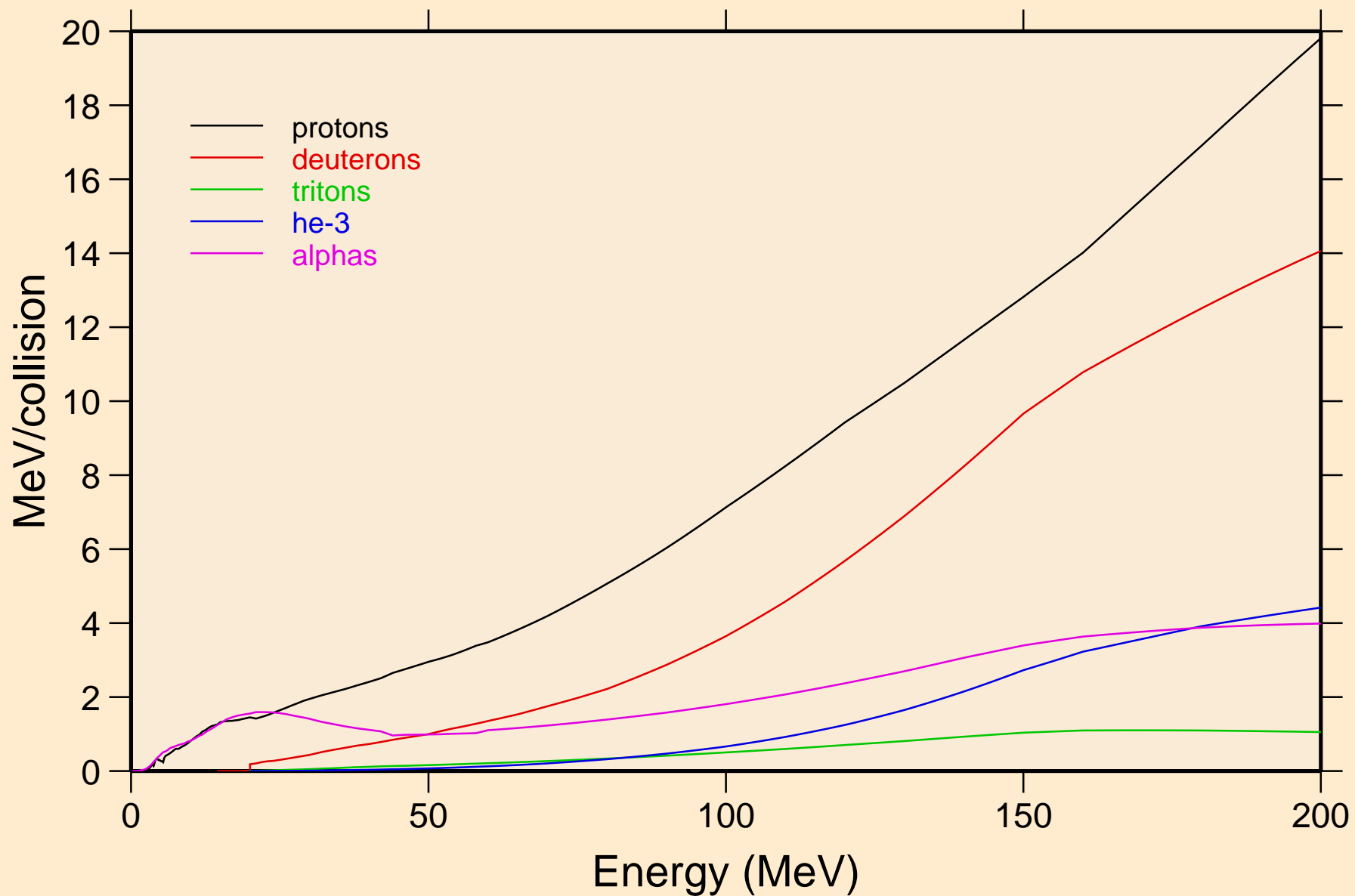

16-S-32 FOR FENDL-3.1 FROM TENDL-2010 WITH NJOY2012.50+

Recoil Heating

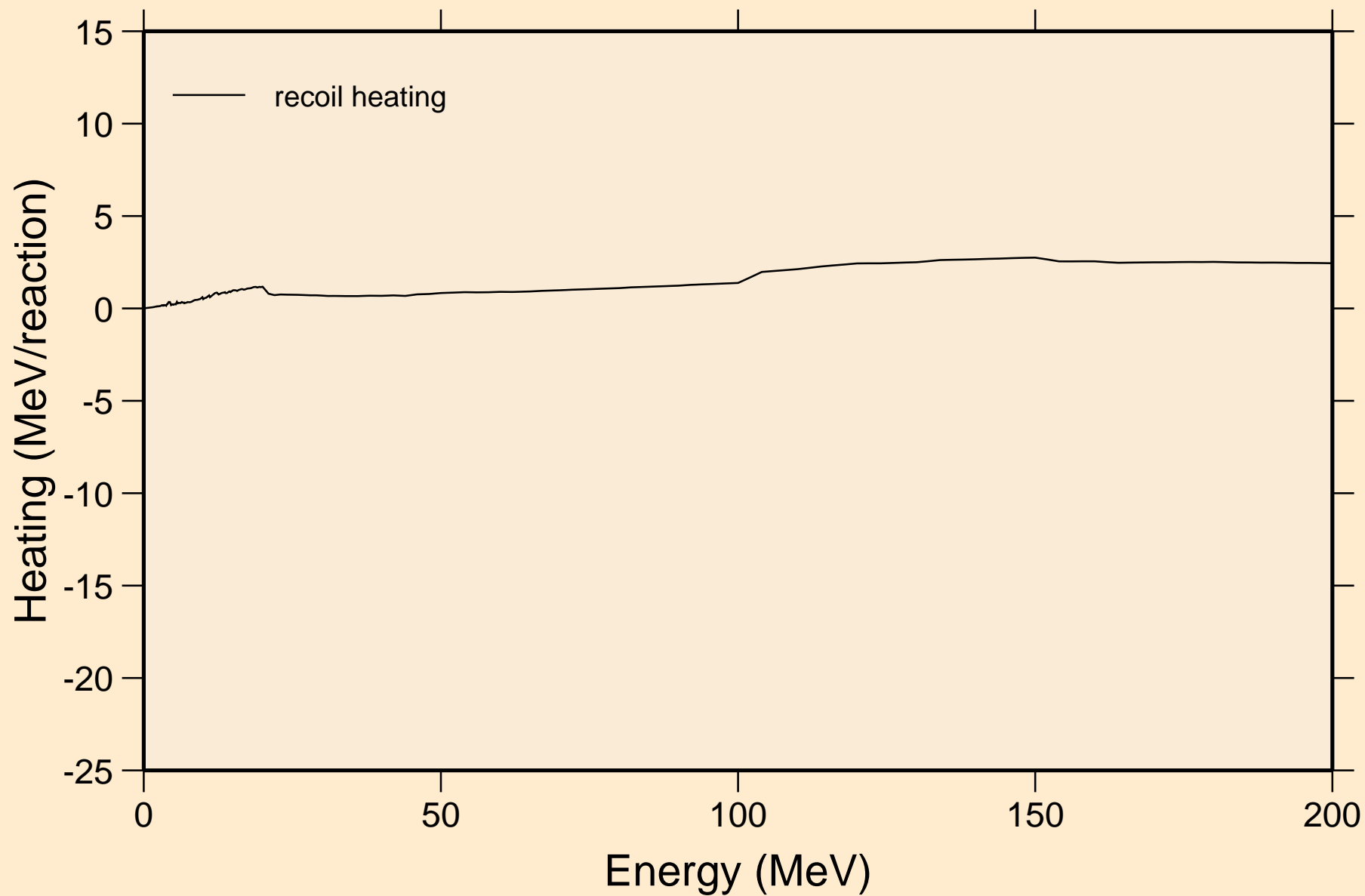

16-S-32 FOR FENDL-3.1 FROM TENDL-2010 WITH NJOY2012.50+

Particle production cross sections

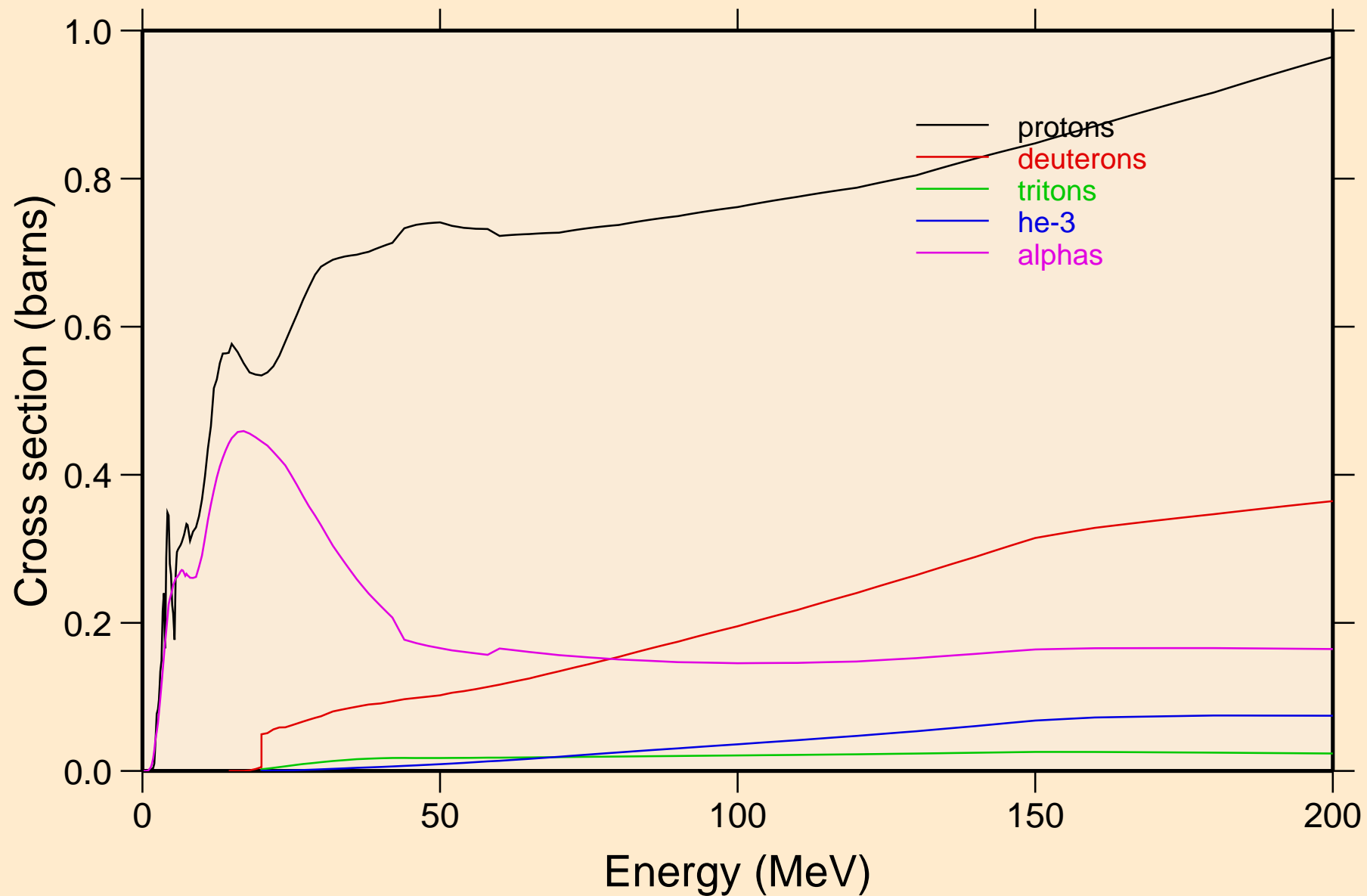

16-S-32 FOR FENDL-3.1 FROM TENDL-2010 WITH NJOY2012.50+
protons from (n,x)

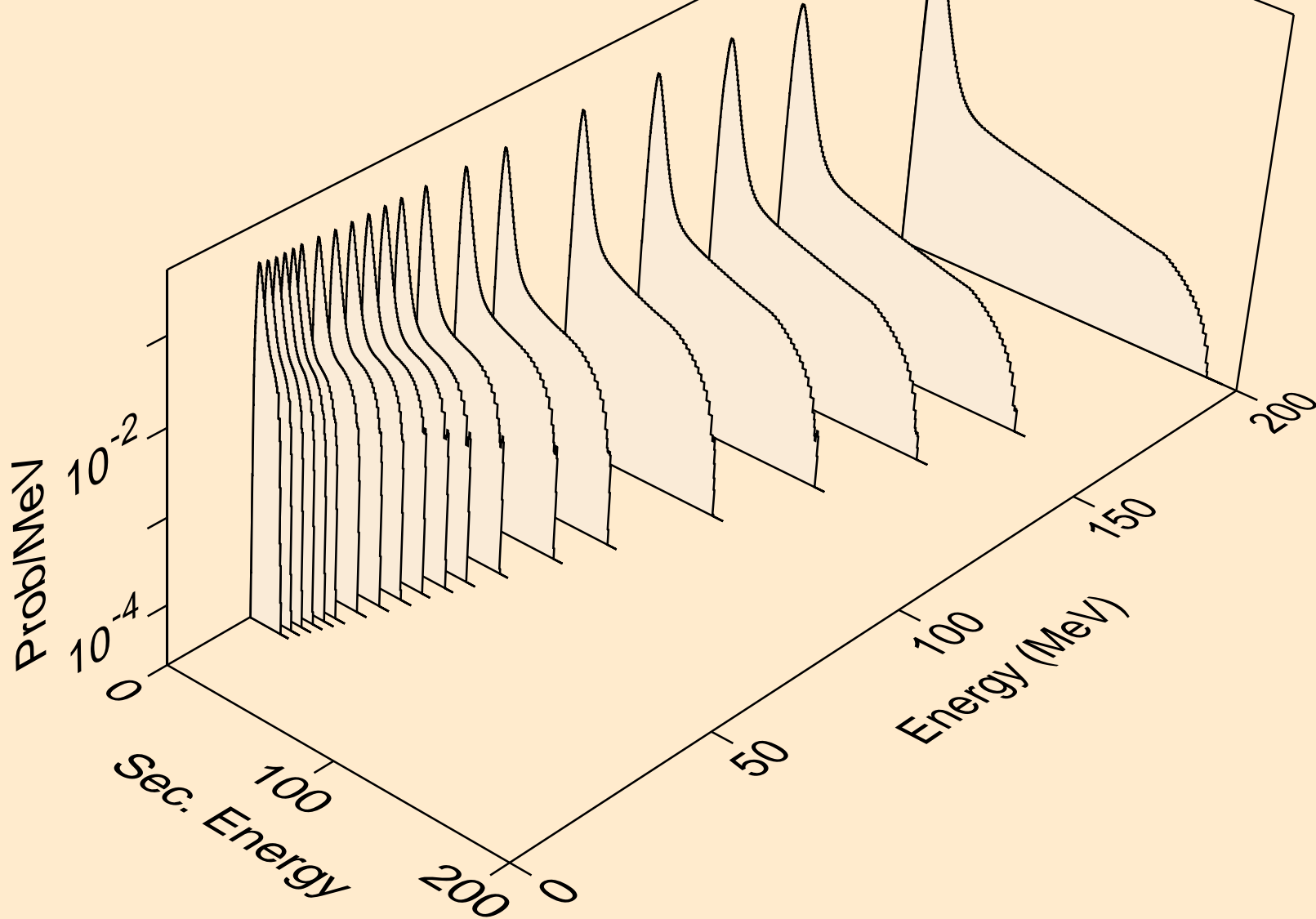

16-S-32 FOR FENDL-3.1 FROM TENDL-2010 WITH NJOY2012.50+
protons from (n,n*)p

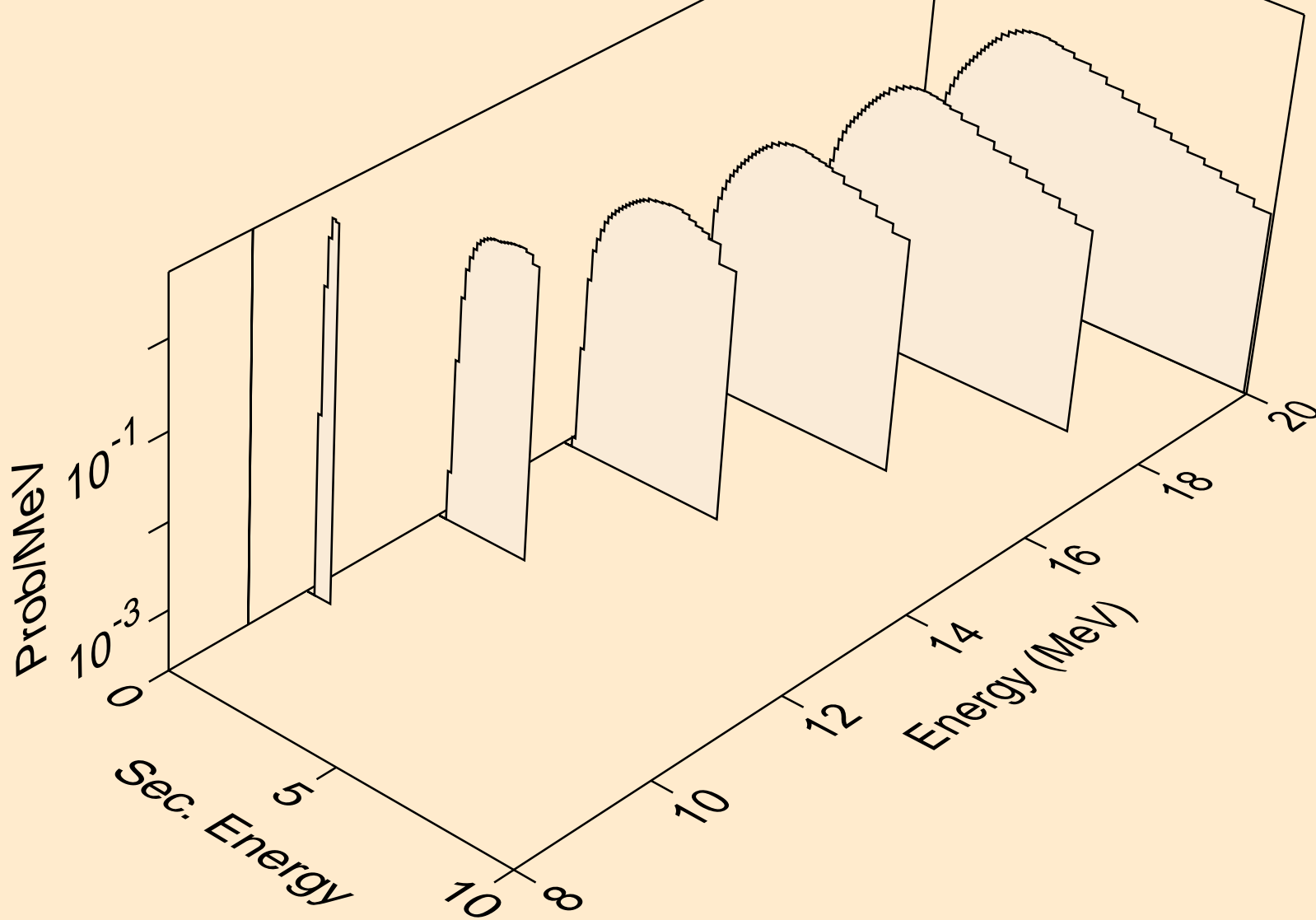

16-S-32 FOR FENDL-3.1 FROM TENDL-2010 WITH NJOY2012.50+
protons from (n,2np)

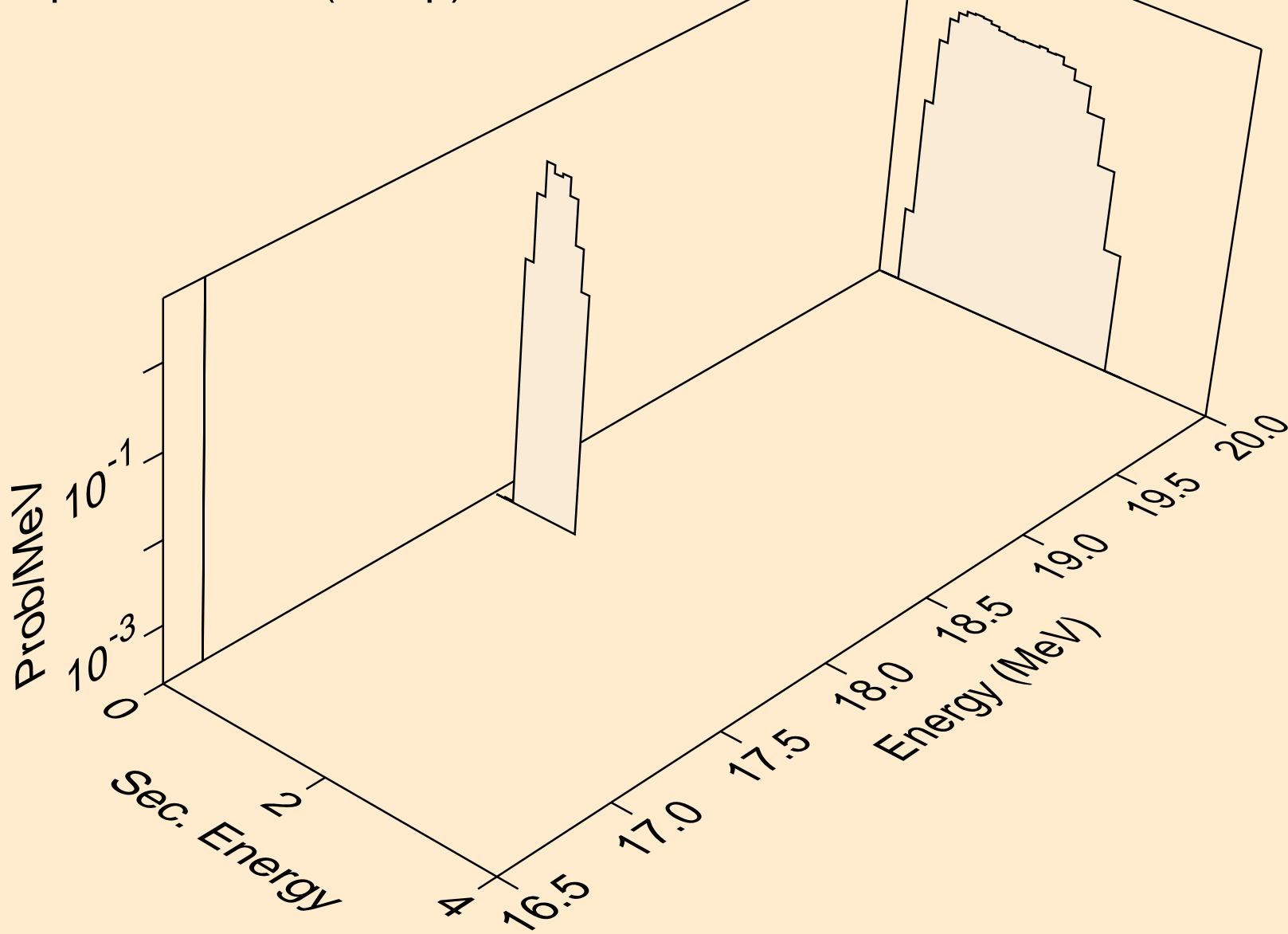

16-S-32 FOR FENDL-3.1 FROM TENDL-2010 WITH NJOY2012.50+
protons from (n,2p)

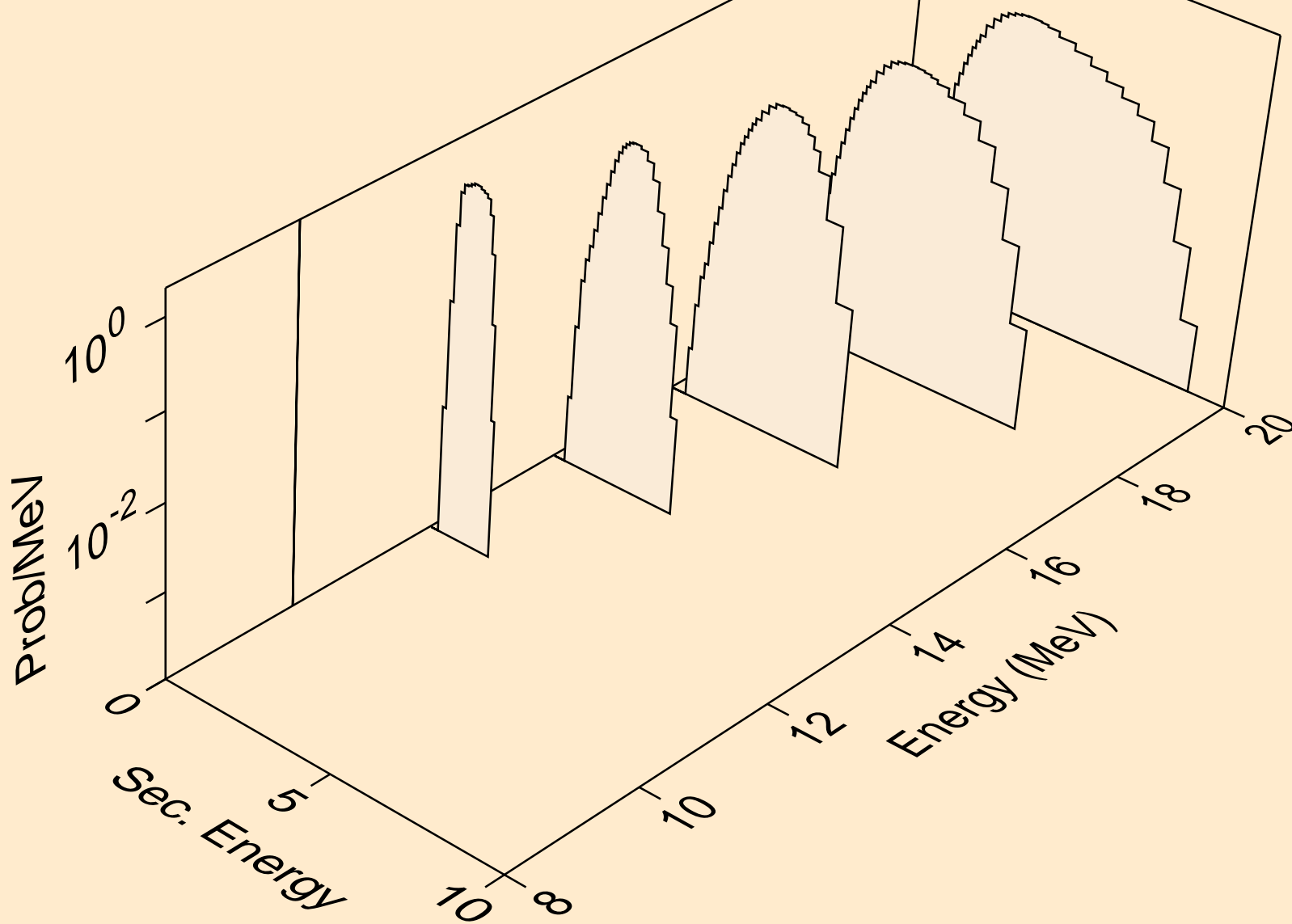

16-S-32 FOR FENDL-3.1 FROM TENDL-2010 WITH NJOY2012.50+
protons from (n,pa)

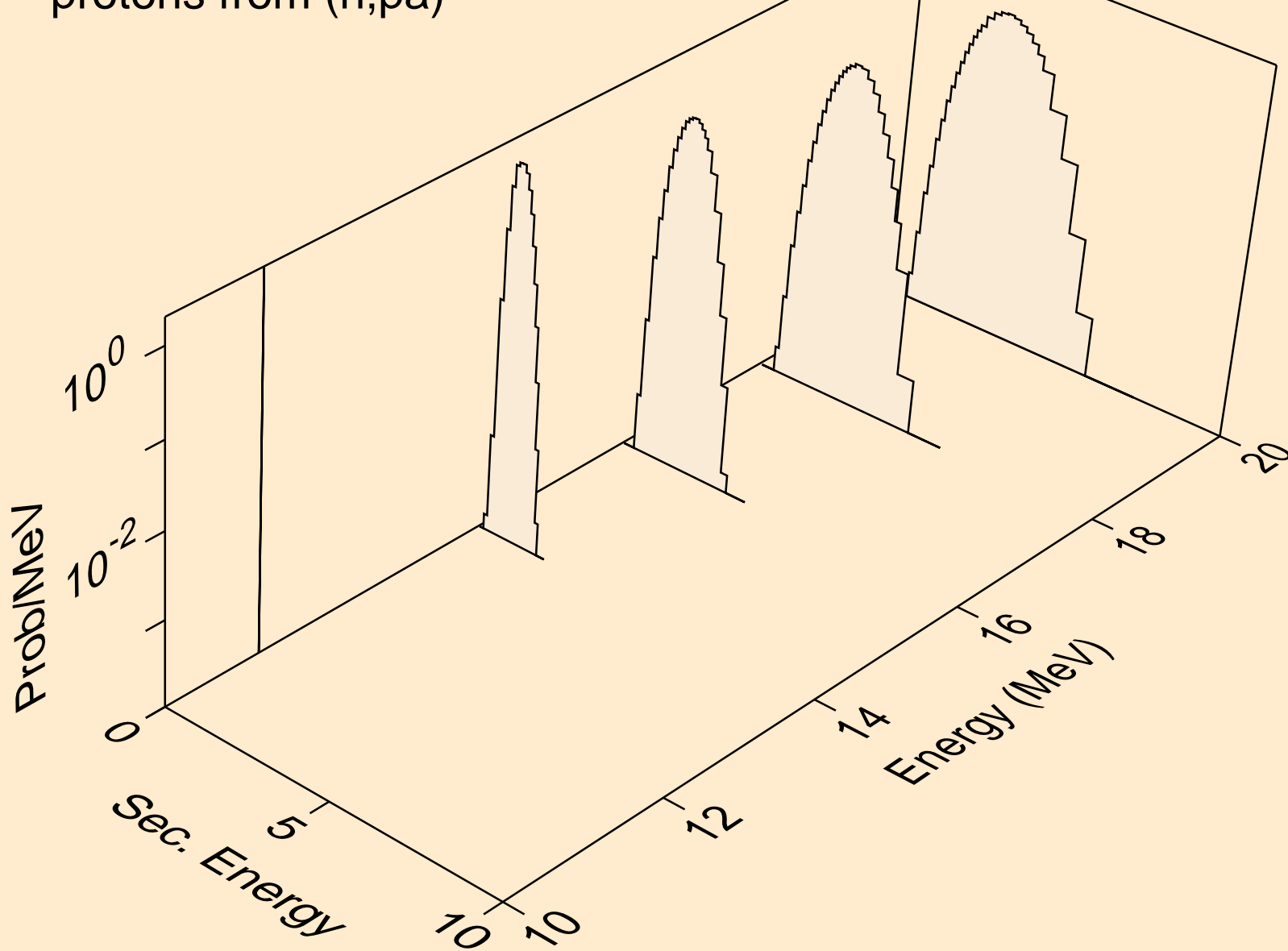

16-S-32 FOR FENDL-3.1 FROM TENDL-2010 WITH NJOY2012.50+
protons from (n,pd)

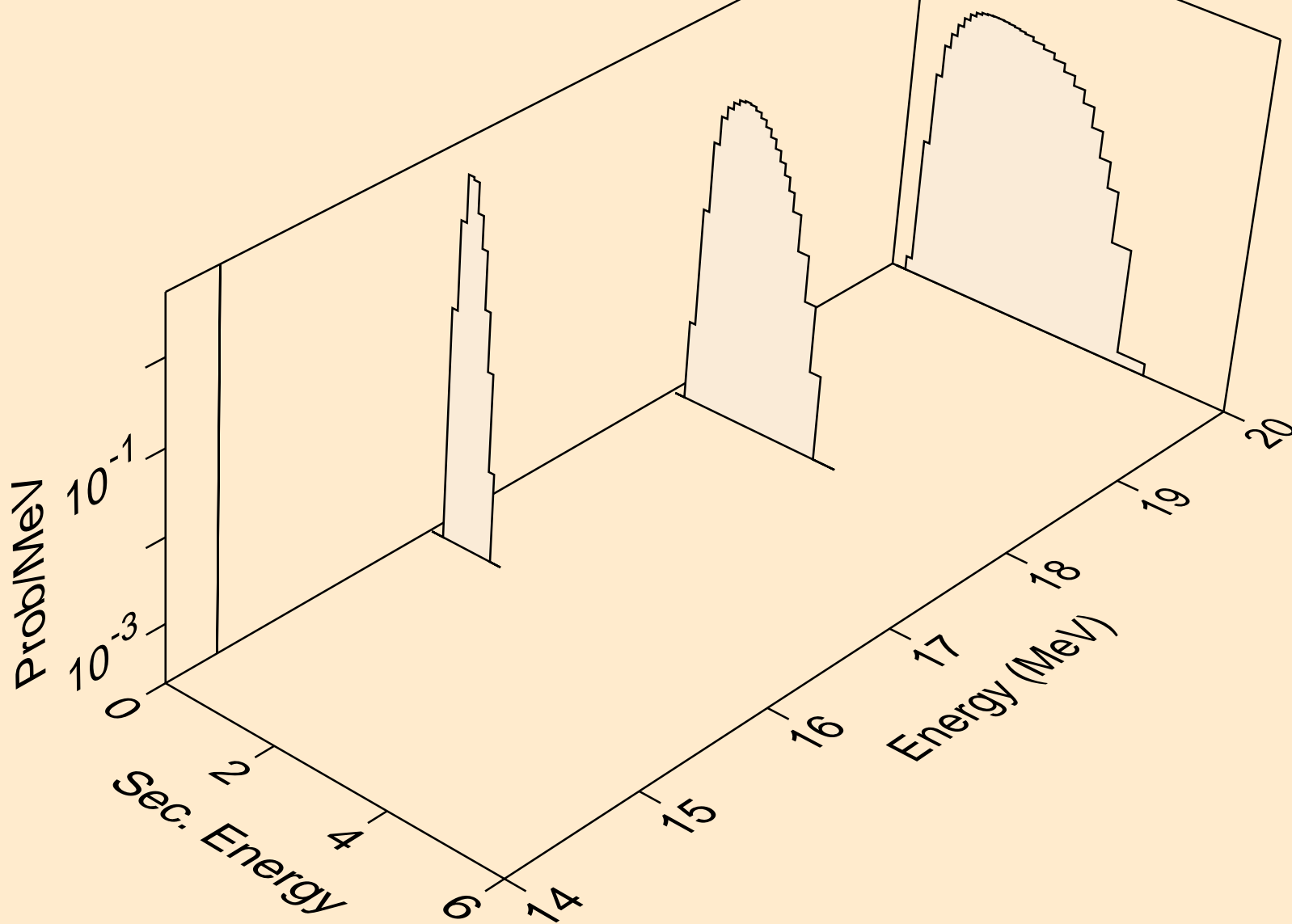

16-S-32 FOR FENDL-3.1 FROM TENDL-2010 WITH NJOY2012.50+
angular distribution for (n,p*0) proton

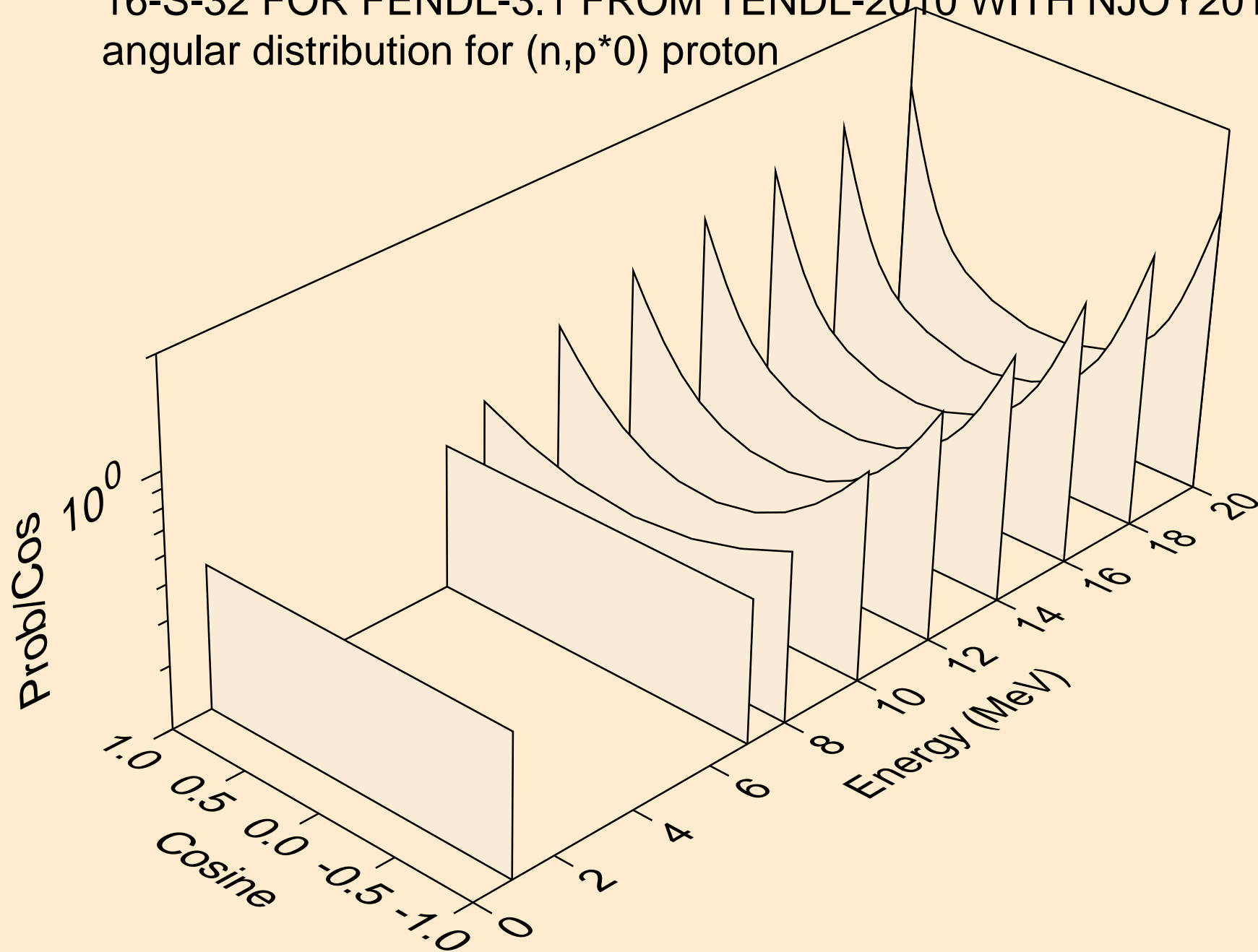

16-S-32 FOR FENDL-3.1 FROM TENDL-2010 WITH NJOY2012.50+
angular distribution for (n,p*1) proton

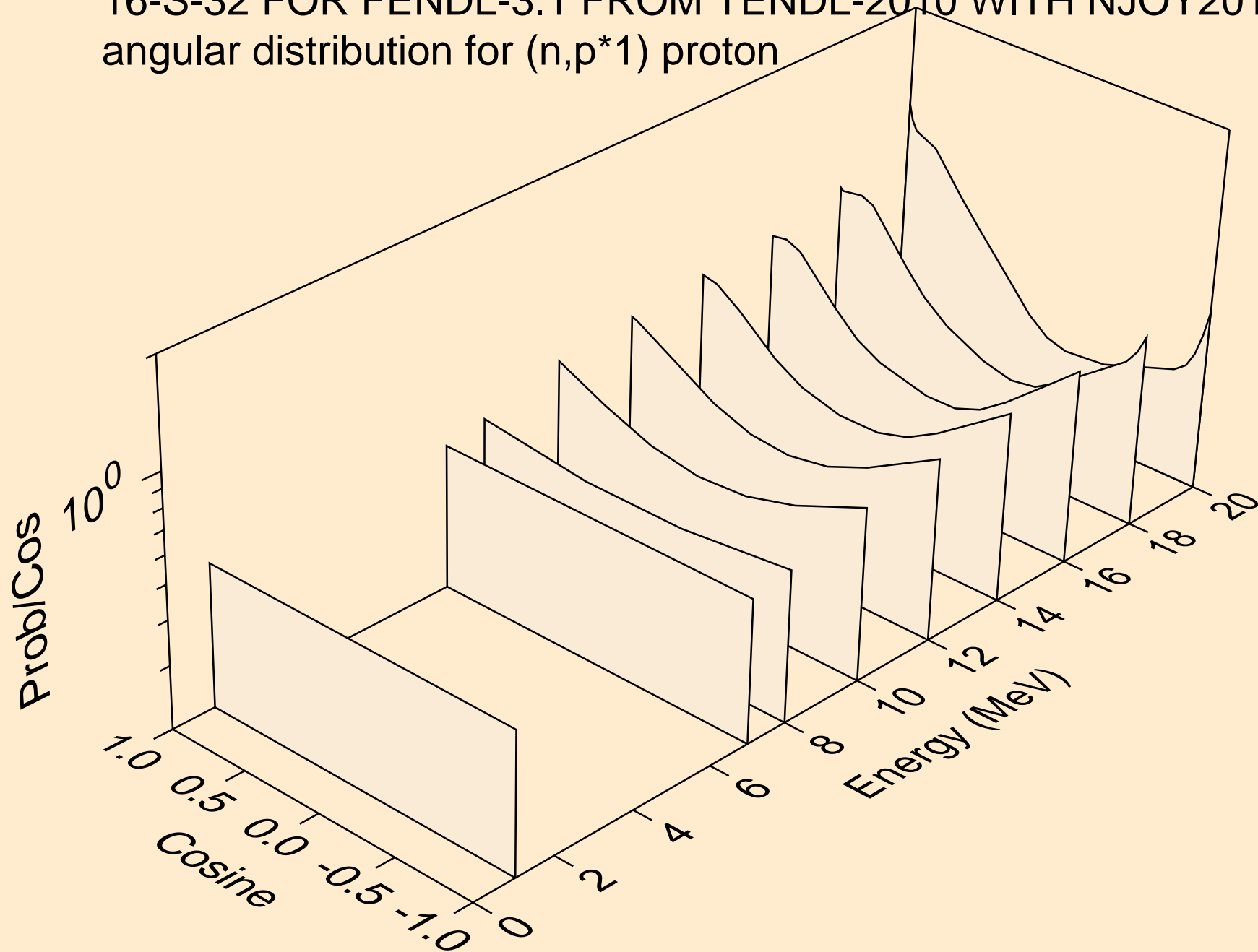

16-S-32 FOR FENDL-3.1 FROM TENDL-2010 WITH NJOY2012.50+
angular distribution for (n,p*2) proton

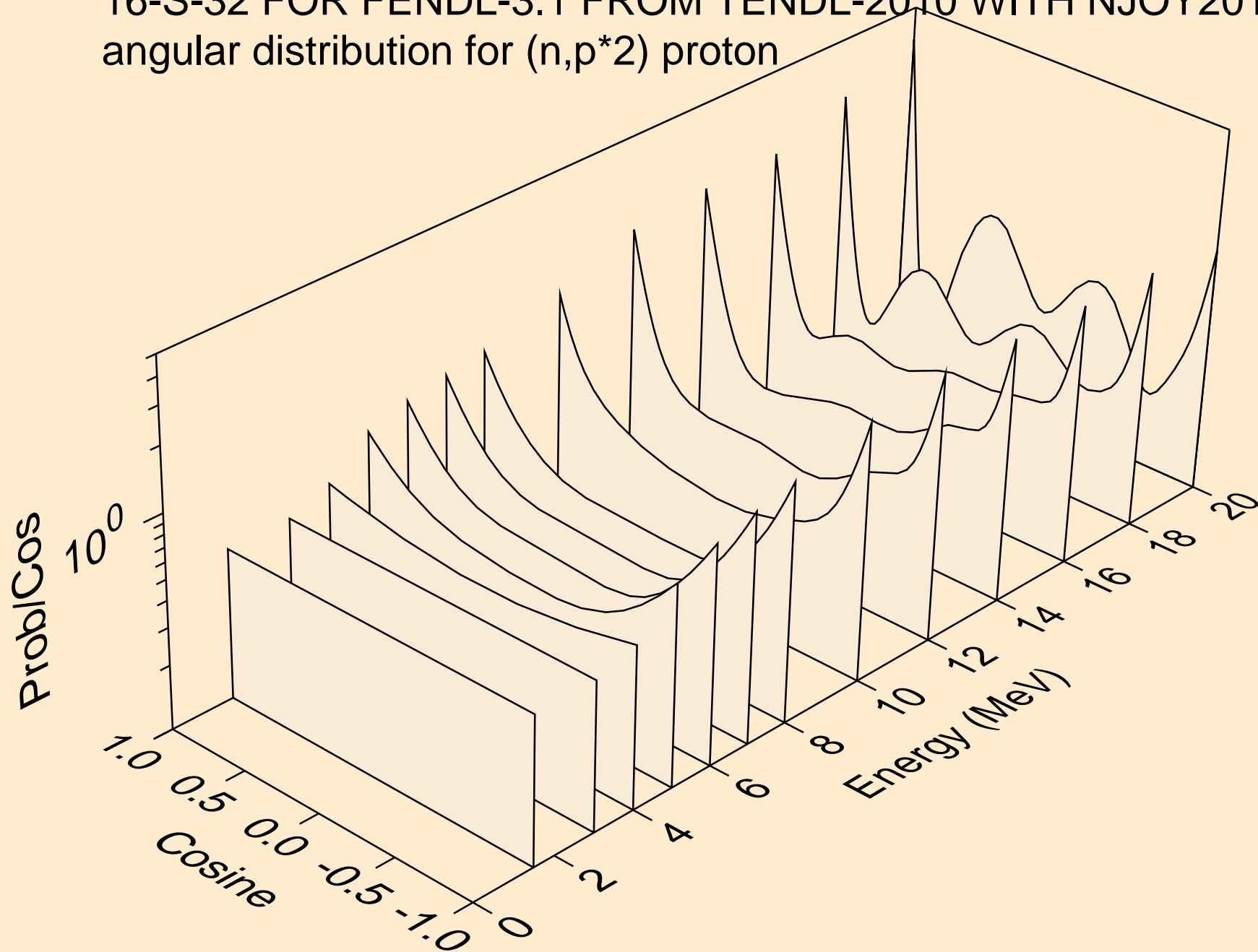

16-S-32 FOR FENDL-3.1 FROM TENDL-2010 WITH NJOY2012.50+
angular distribution for (n,p*3) proton

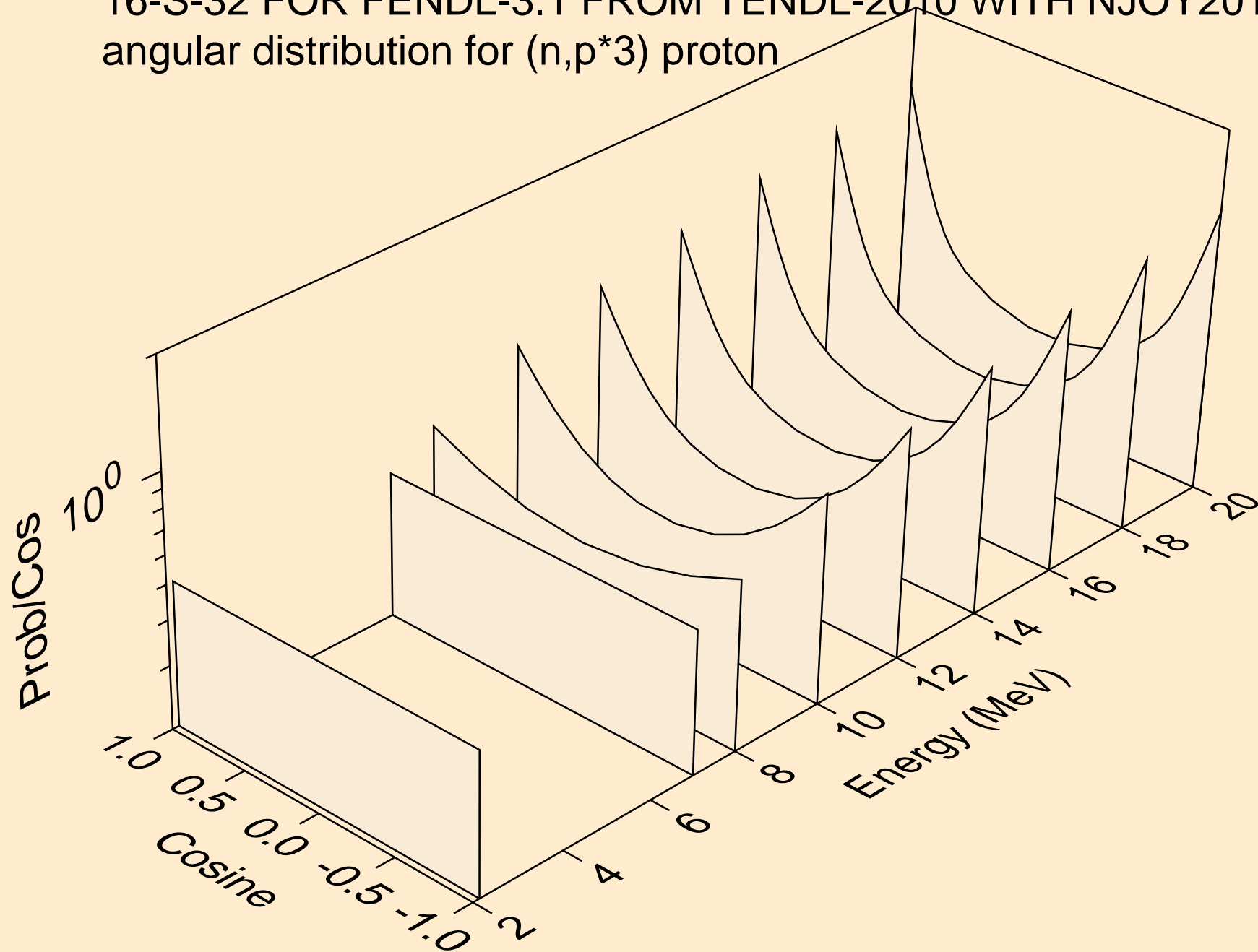

16-S-32 FOR FENDL-3.1 FROM TENDL-2010 WITH NJOY2012.50+
angular distribution for (n,p*4) proton

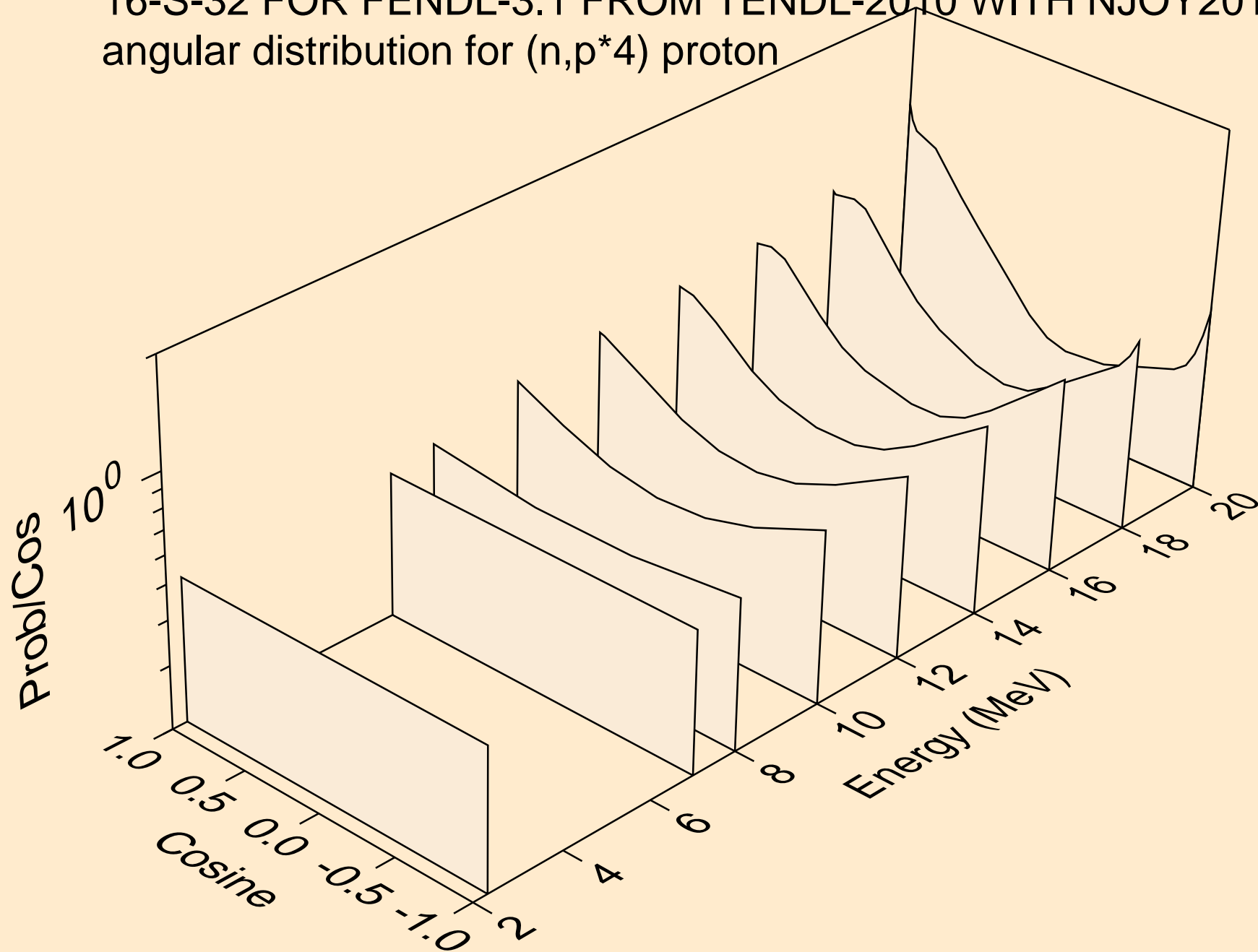

16-S-32 FOR FENDL-3.1 FROM TENDL-2010 WITH NJOY2012.50+
angular distribution for (n,p*5) proton

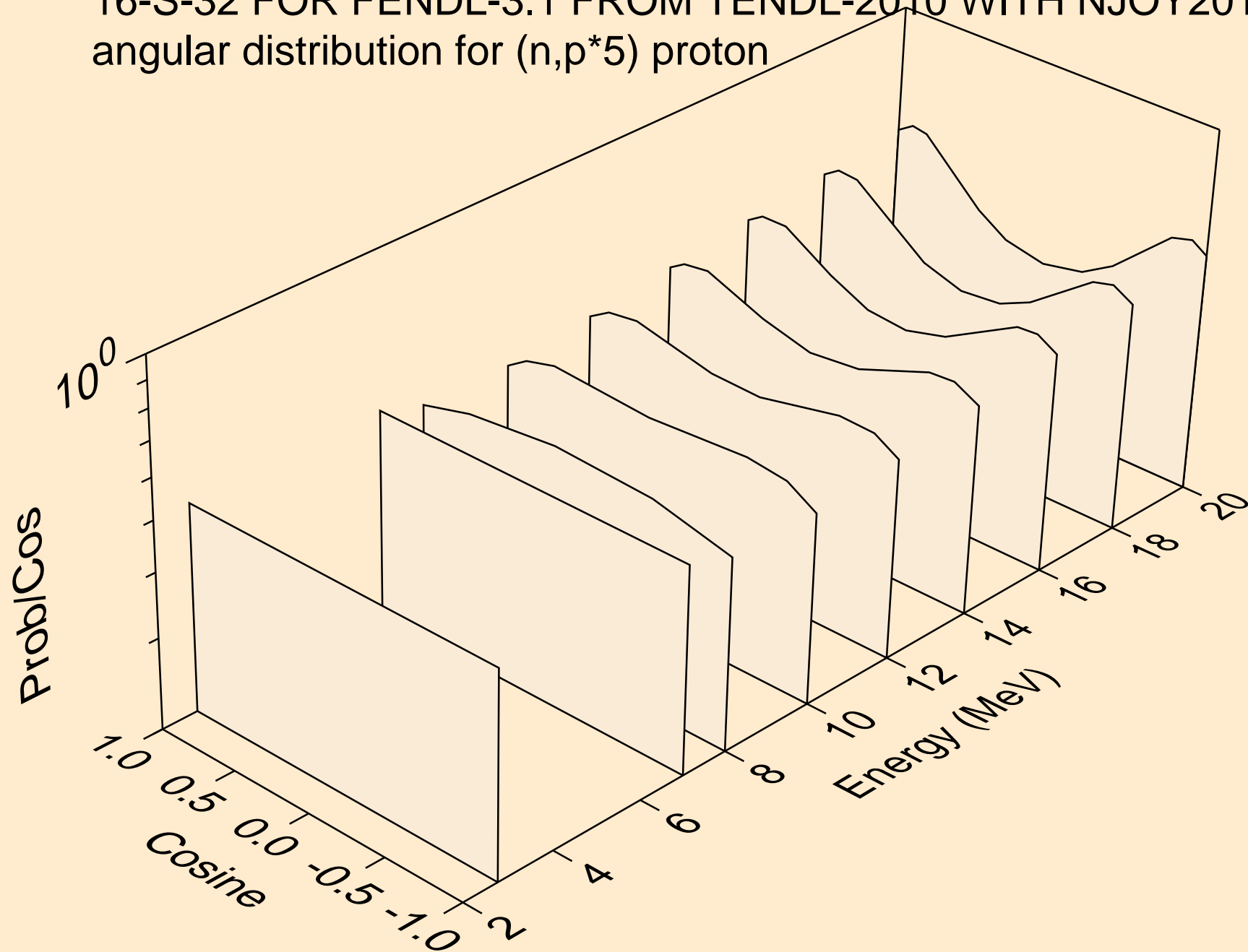

16-S-32 FOR FENDL-3.1 FROM TENDL-2010 WITH NJOY2012.50+
angular distribution for (n,p*6) proton

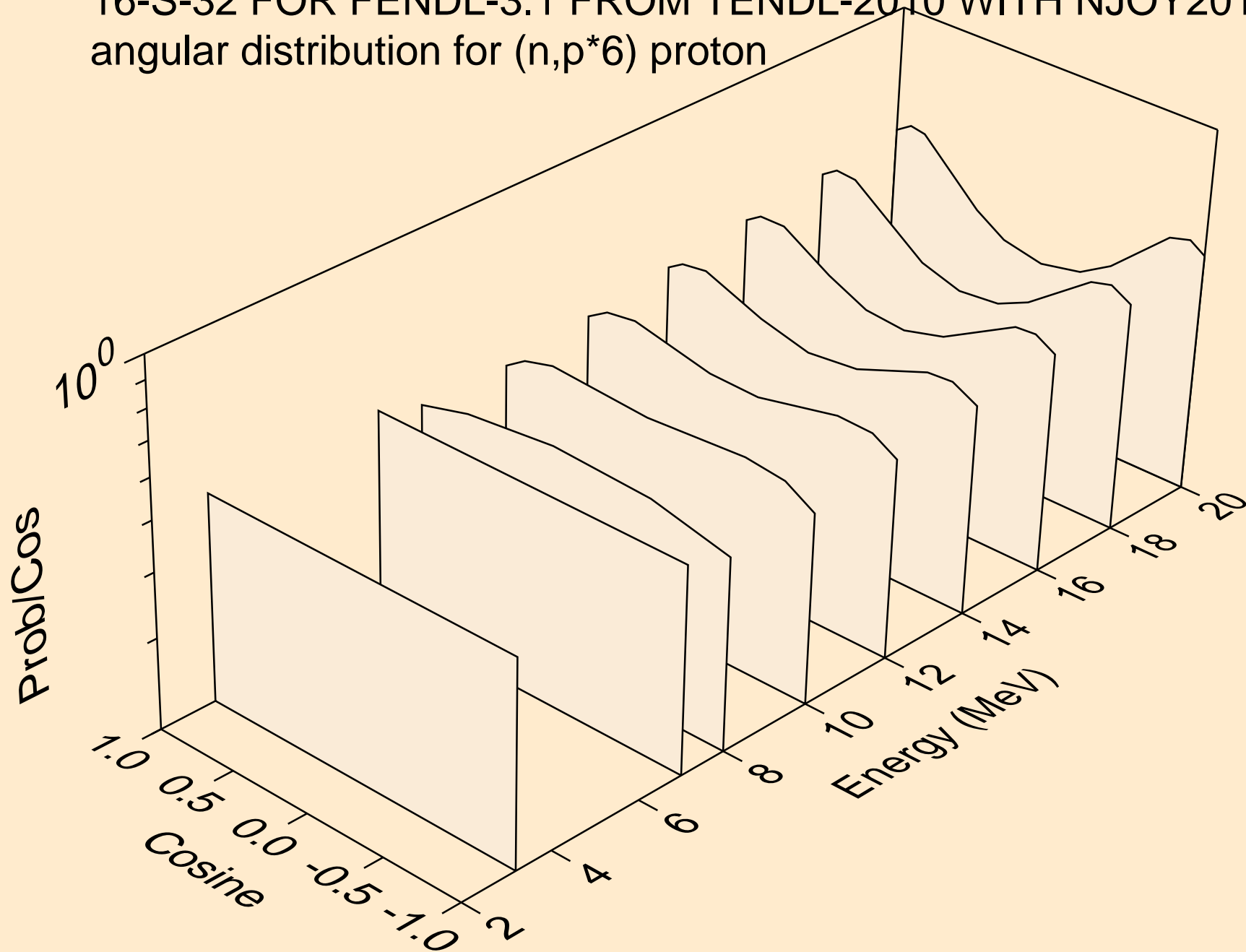

16-S-32 FOR FENDL-3.1 FROM TENDL-2010 WITH NJOY2012.50+
angular distribution for (n,p*7) proton

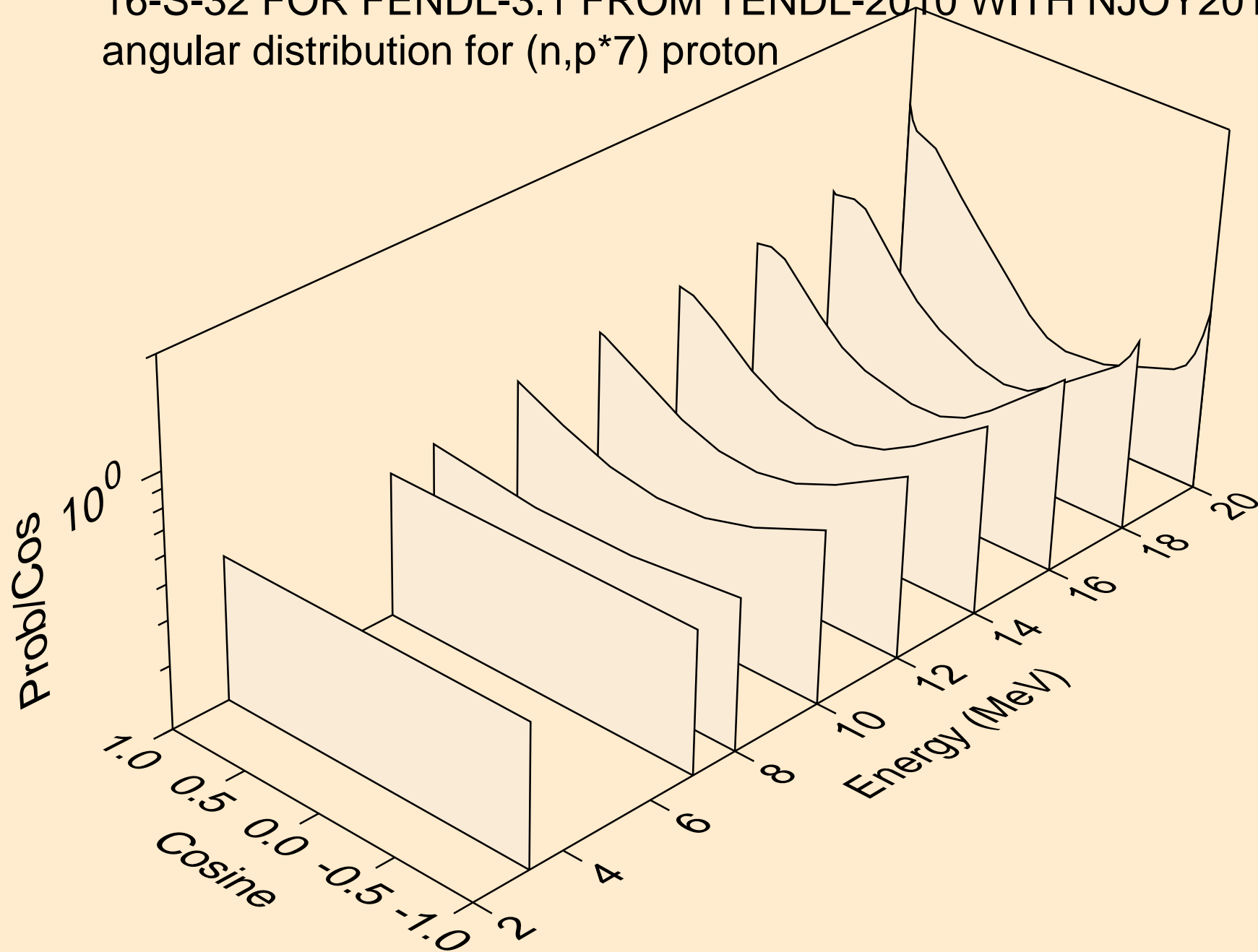

16-S-32 FOR FENDL-3.1 FROM TENDL-2010 WITH NJOY2012.50+
angular distribution for (n,p*8) proton

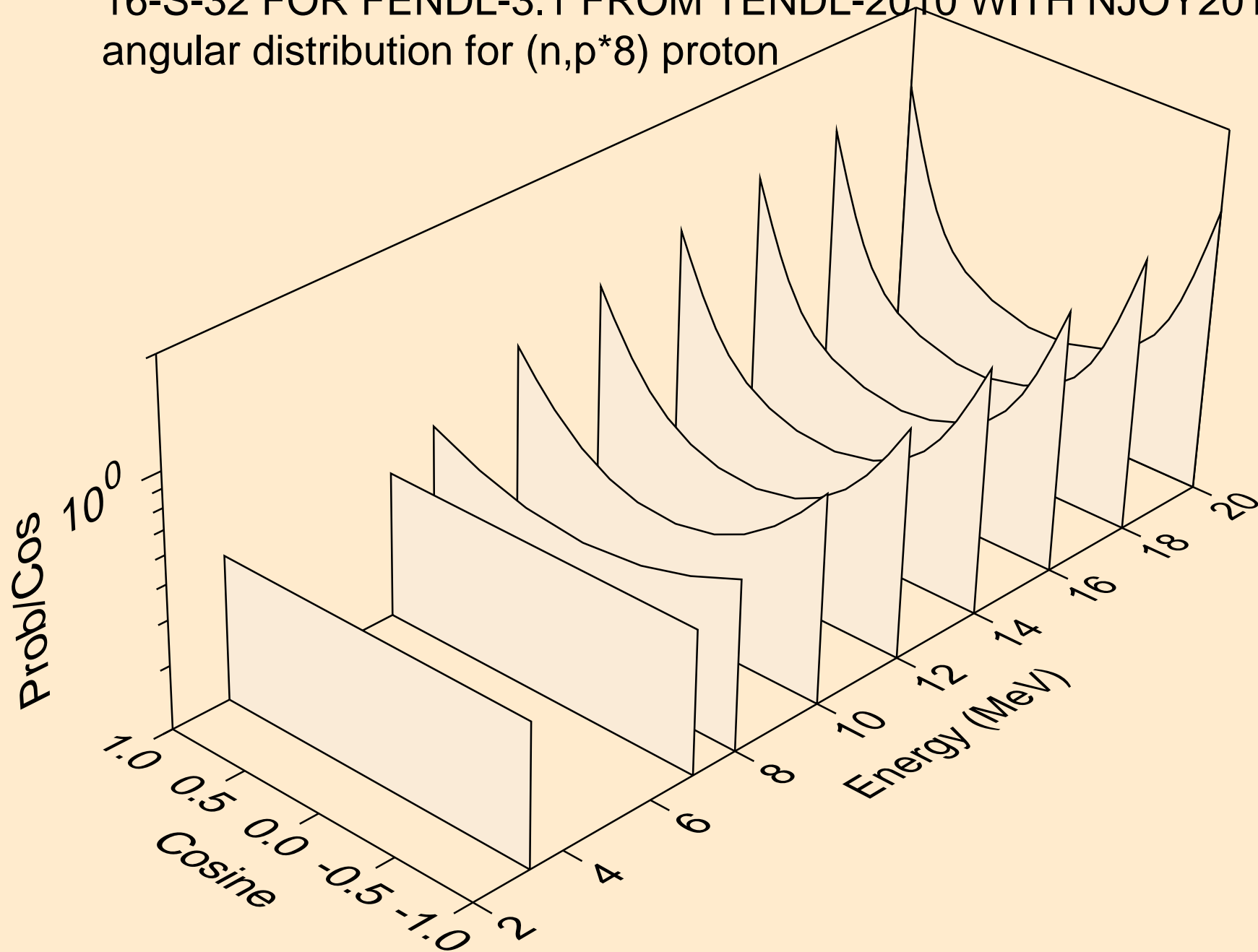

16-S-32 FOR FENDL-3.1 FROM TENDL-2010 WITH NJOY2012.50+
angular distribution for (n,p*9) proton

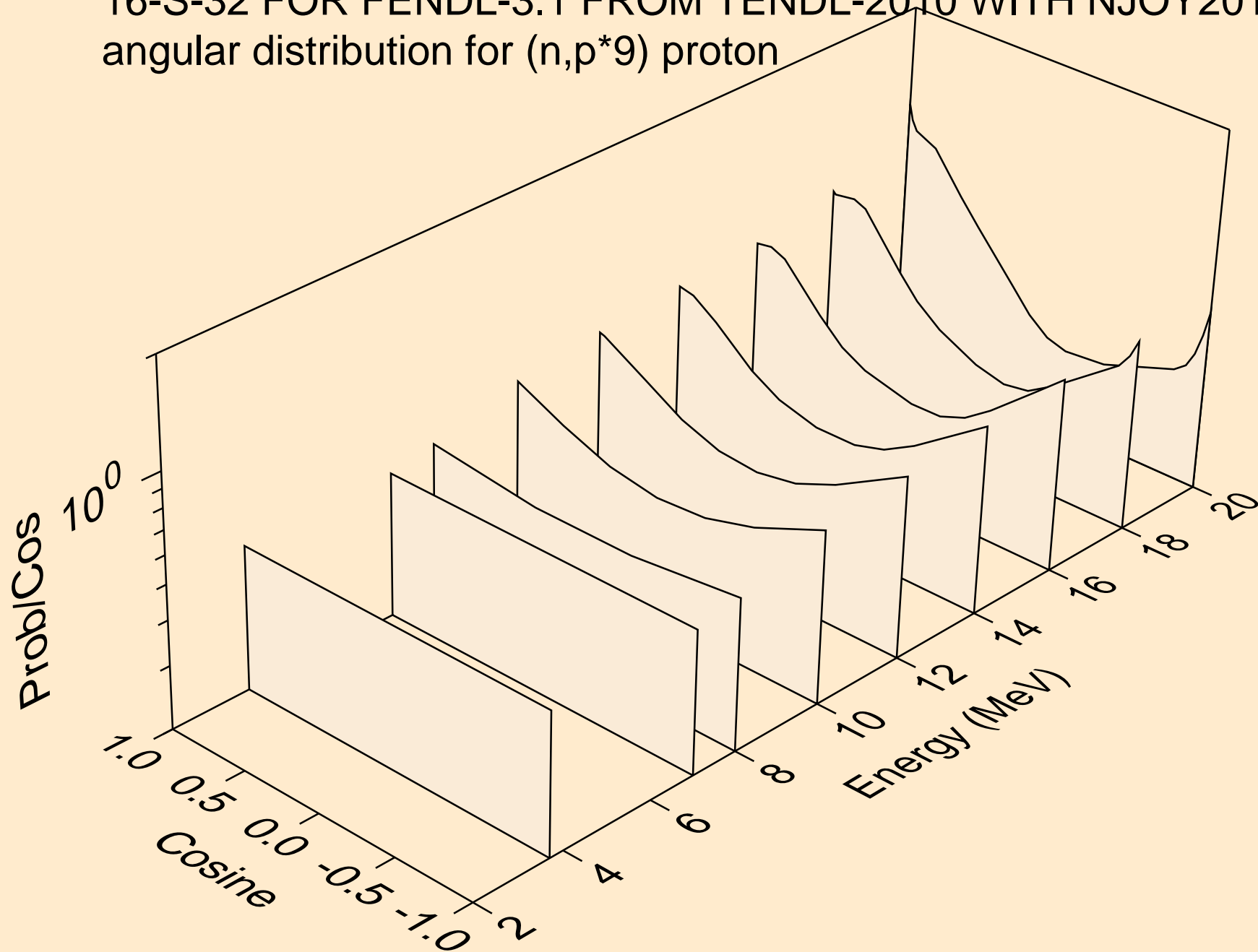

16-S-32 FOR FENDL-3.1 FROM TENDL-2010 WITH NJOY2012.50+
angular distribution for (n,p*10) proton

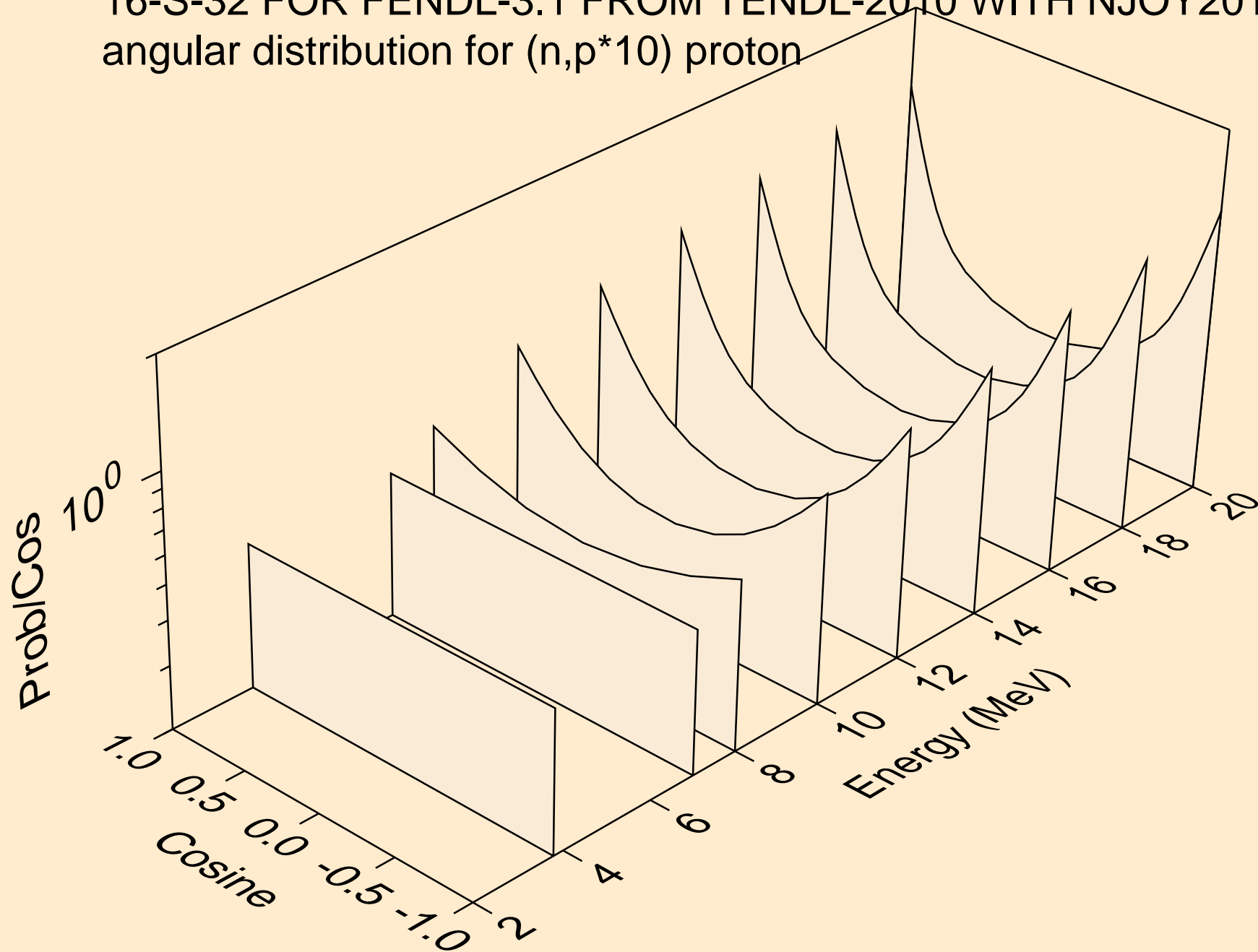

16-S-32 FOR FENDL-3.1 FROM TENDL-2010 WITH NJOY2012.50+
protons from (n,p*c)

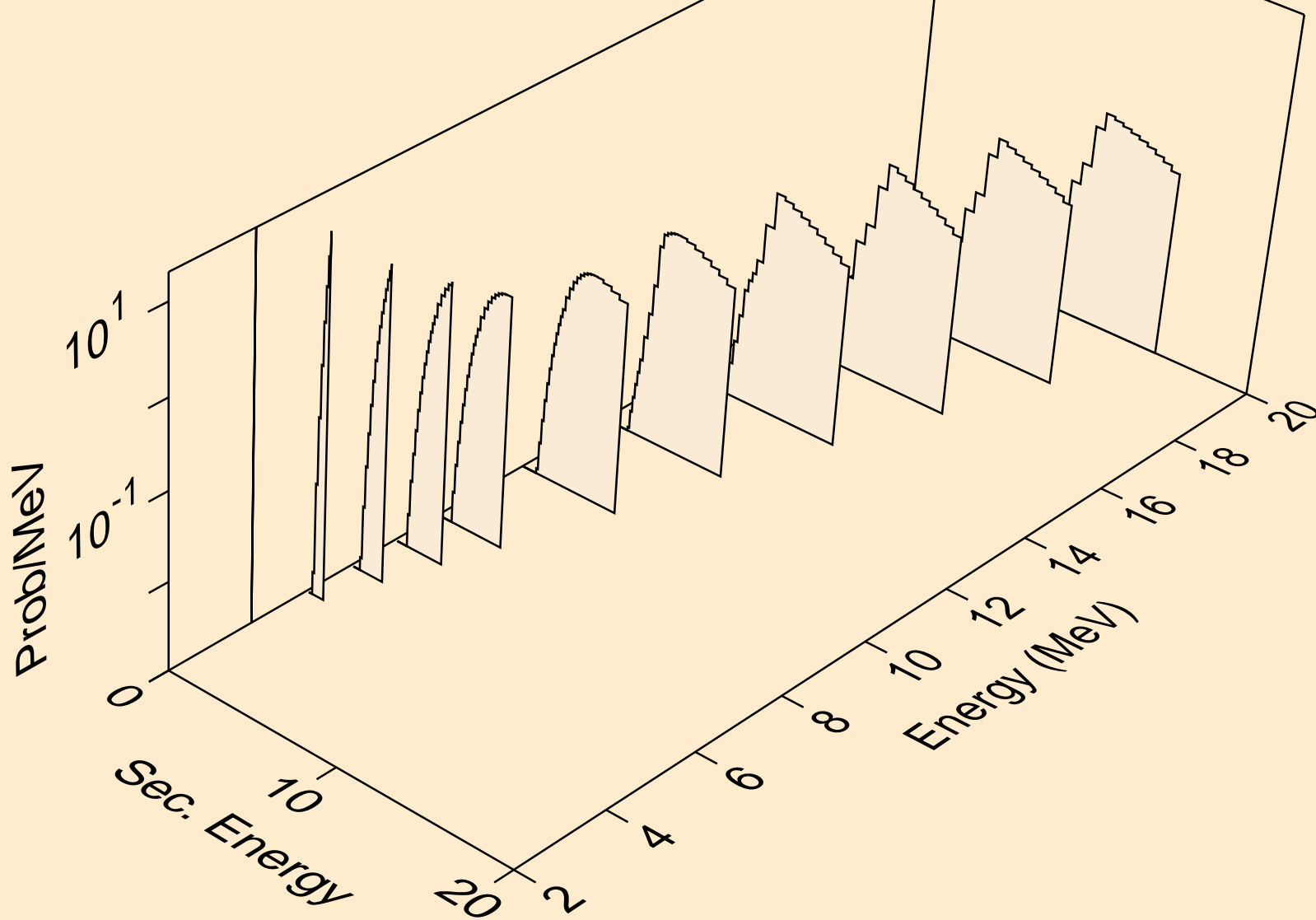

16-S-32 FOR FENDL-3.1 FROM TENDL-2010 WITH NJOY2012.50+
deuterons from (n,x)

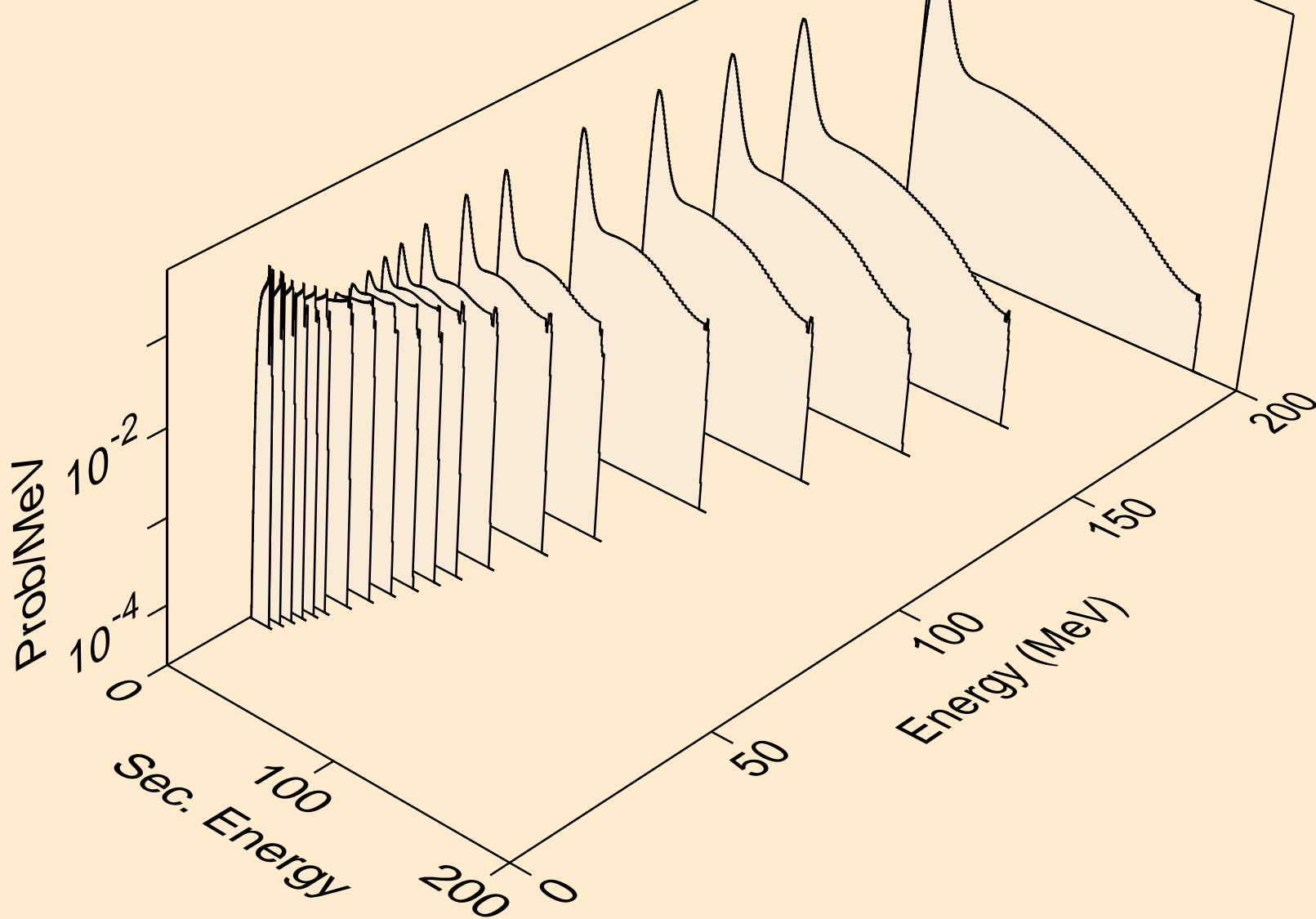

16-S-32 FOR FENDL-3.1 FROM TENDL-2010 WITH NJOY2012.50+
deuterons from (n,pd)

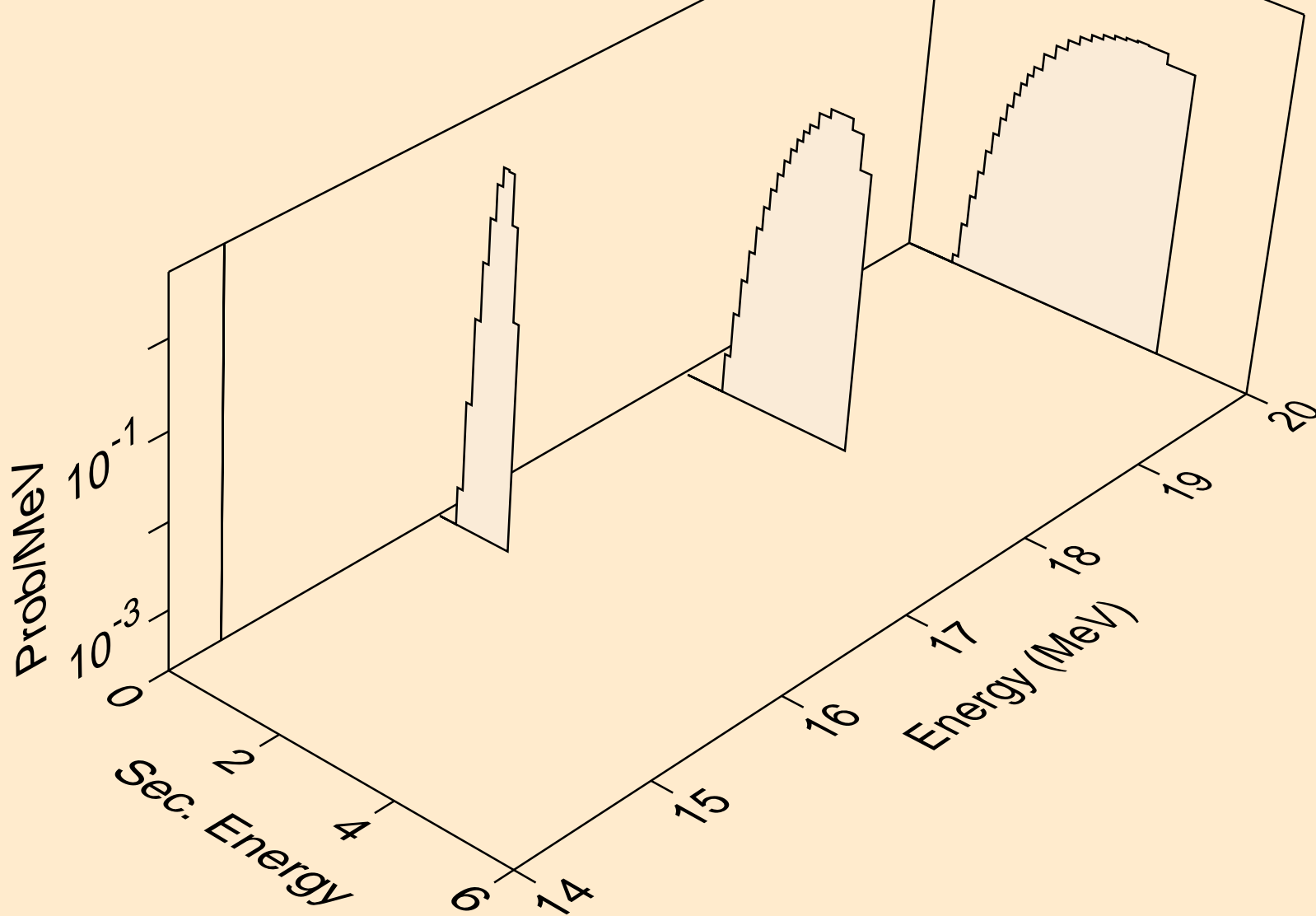

16-S-32 FOR FENDL-3.1 FROM TENDL-2010 WITH NJOY2012.50+
tritons from (n,x)

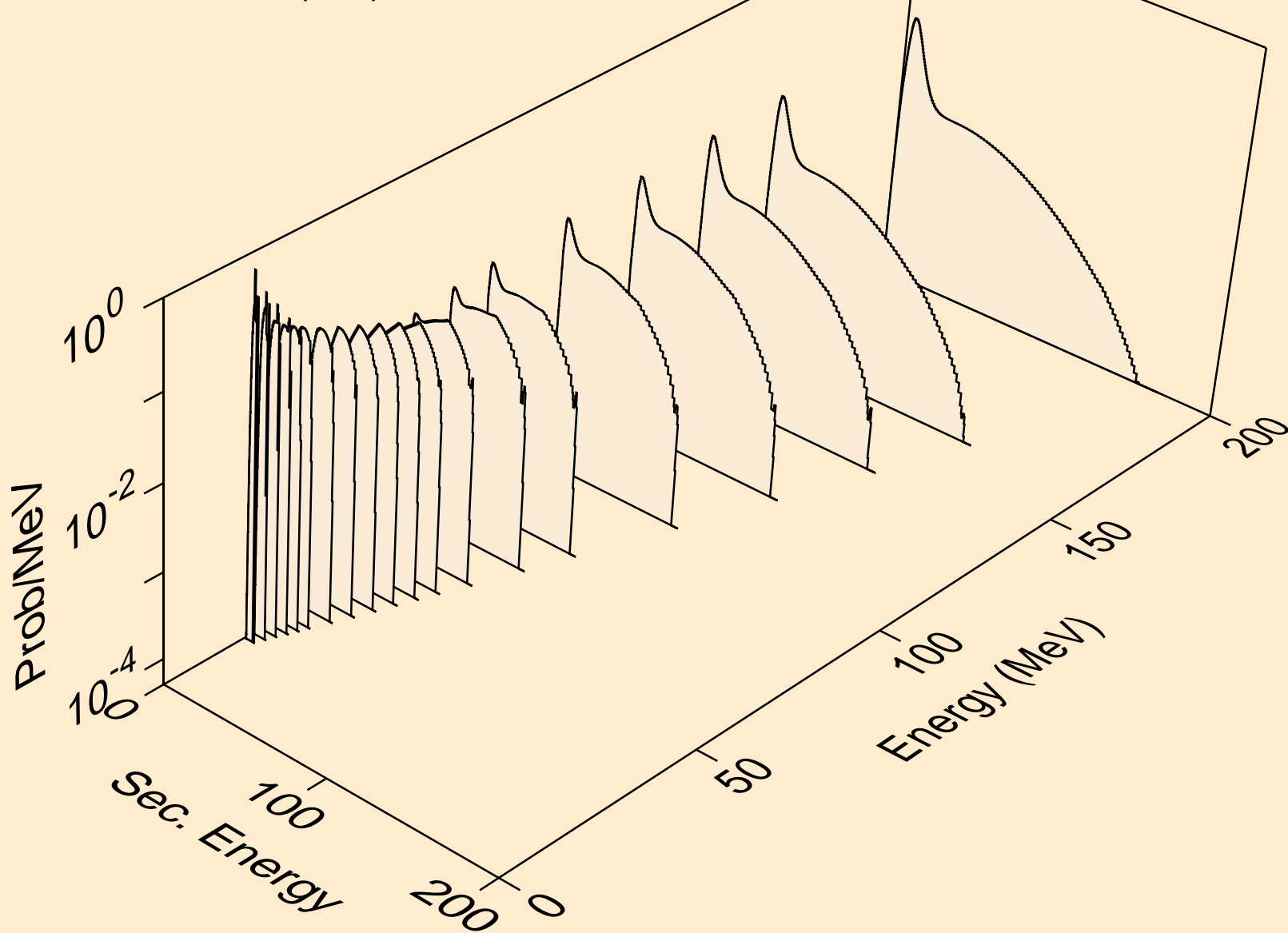

16-S-32 FOR FENDL-3.1 FROM TENDL-2010 WITH NJOY2012.50+
he3s from (n,x)

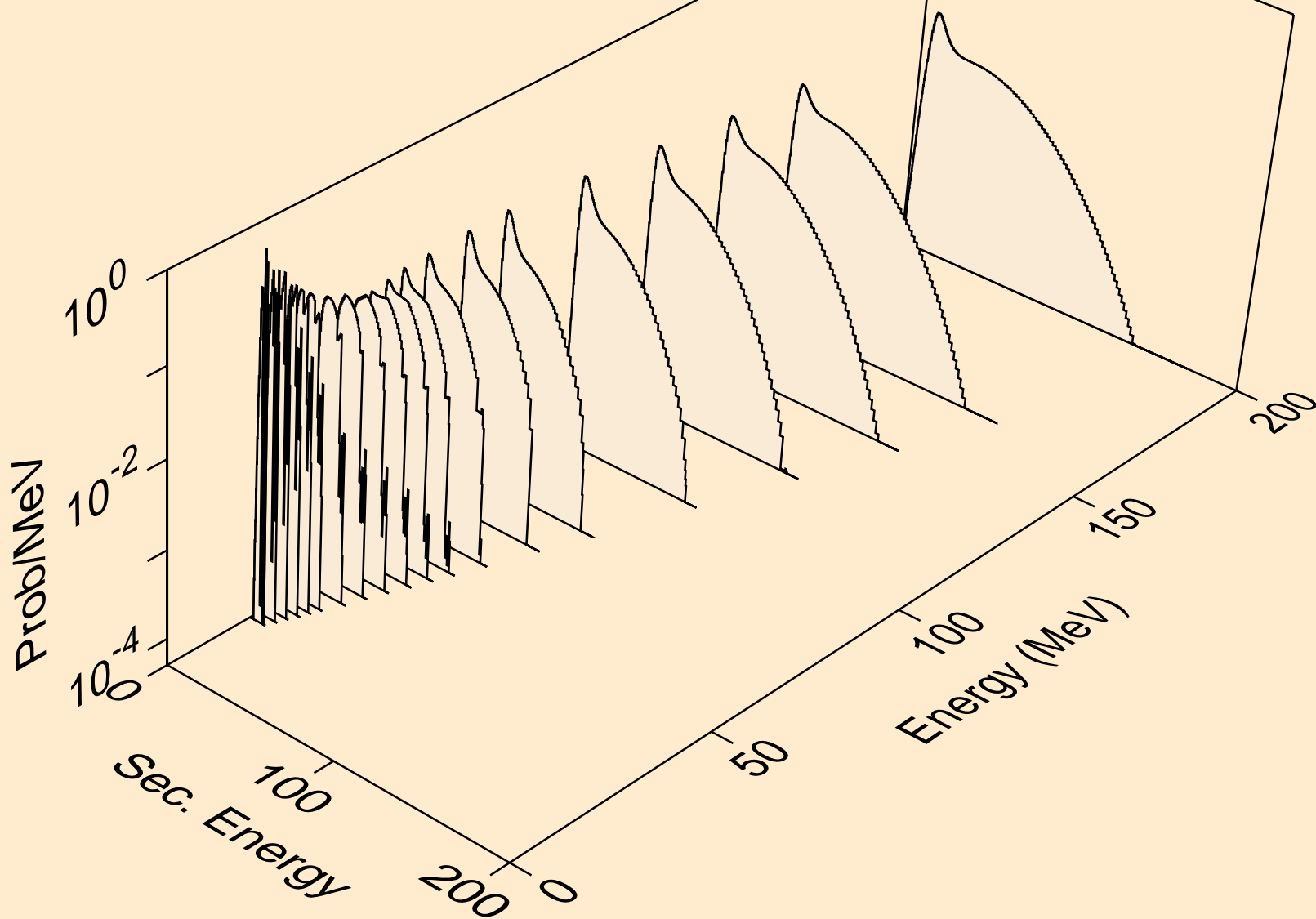

16-S-32 FOR FENDL-3.1 FROM TENDL-2010 WITH NJOY2012.50+
alphas from (n,x)

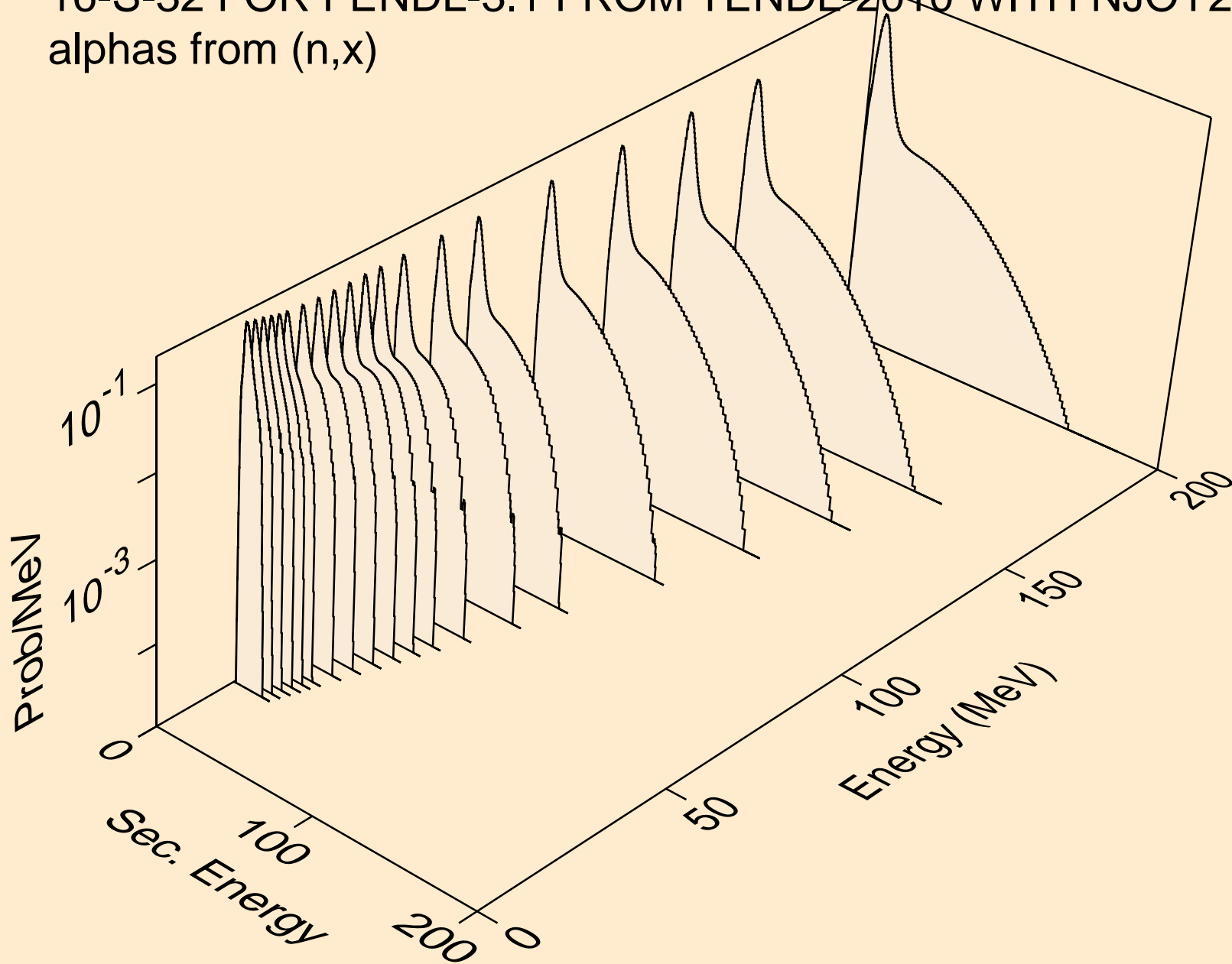

16-S-32 FOR FENDL-3.1 FROM TENDL-2010 WITH NJOY2012.50+
alphas from (n,n*)a

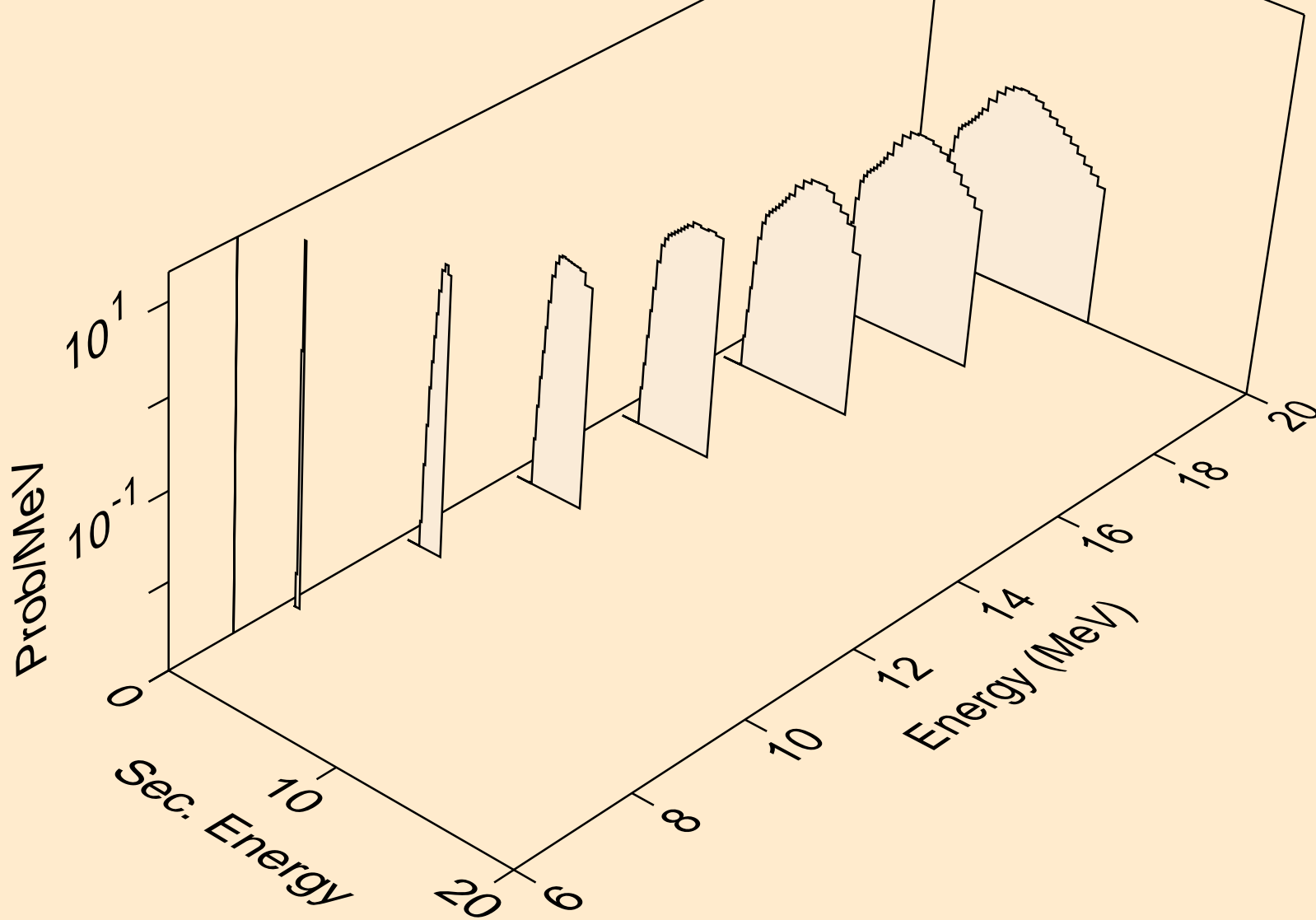

16-S-32 FOR FENDL-3.1 FROM TENDL-2010 WITH NJOY2012.50+
alphas from (n,2a)

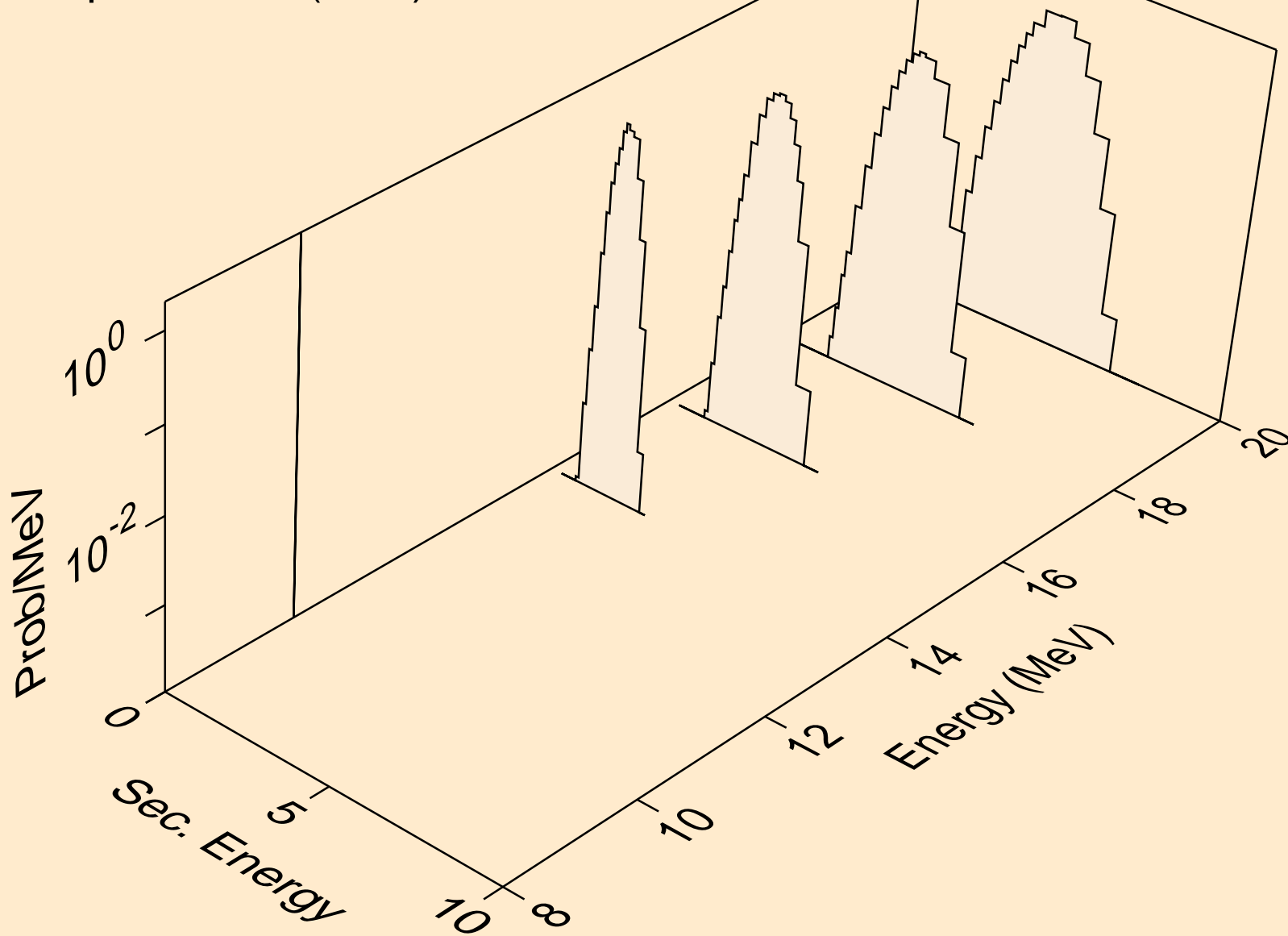

16-S-32 FOR FENDL-3.1 FROM TENDL-2010 WITH NJOY2012.50+
alphas from (n,pa)

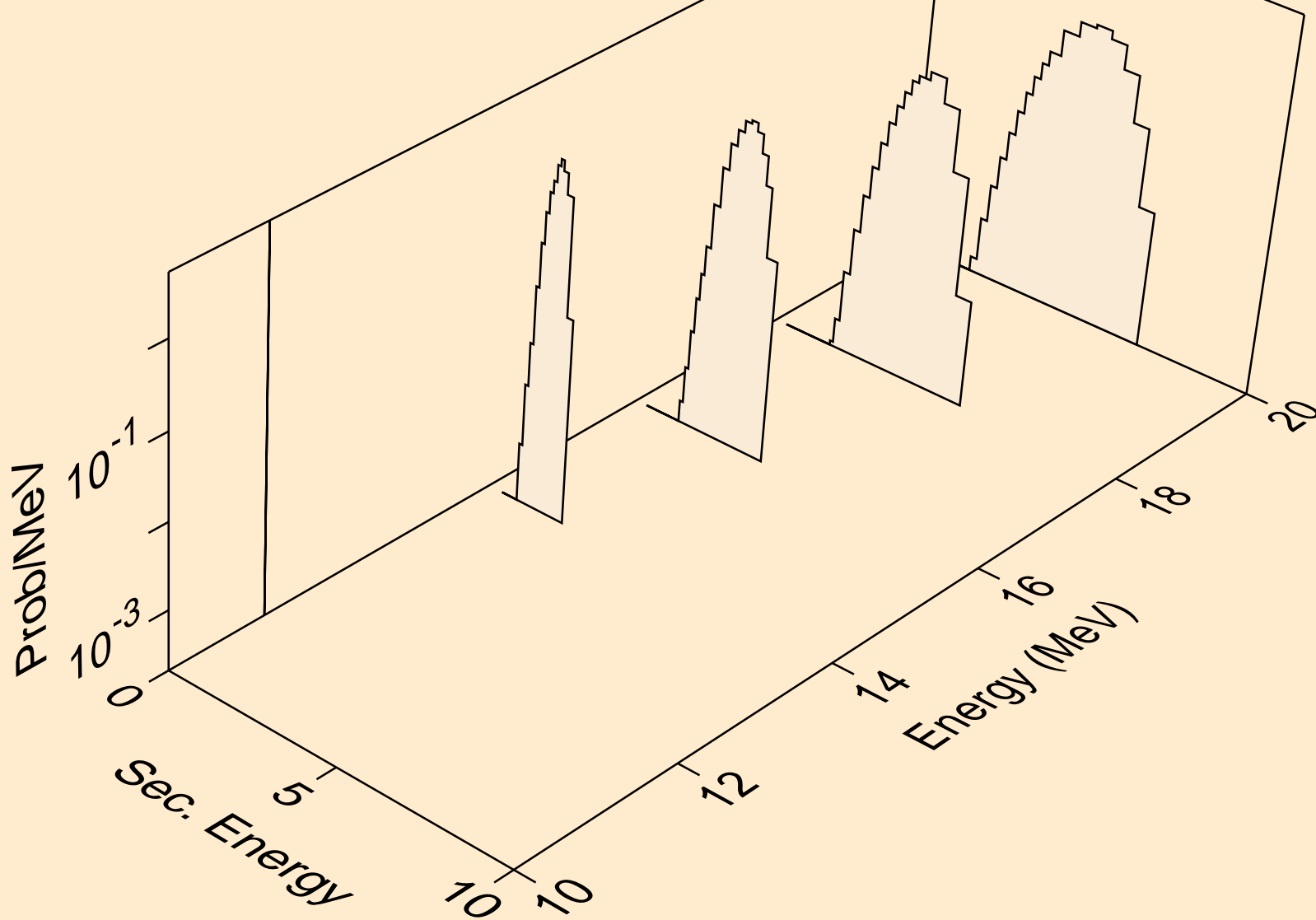

16-S-32 FOR FENDL-3.1 FROM TENDL-2010 WITH NJOY2012.50+
angular distribution for (n,a*0) alpha

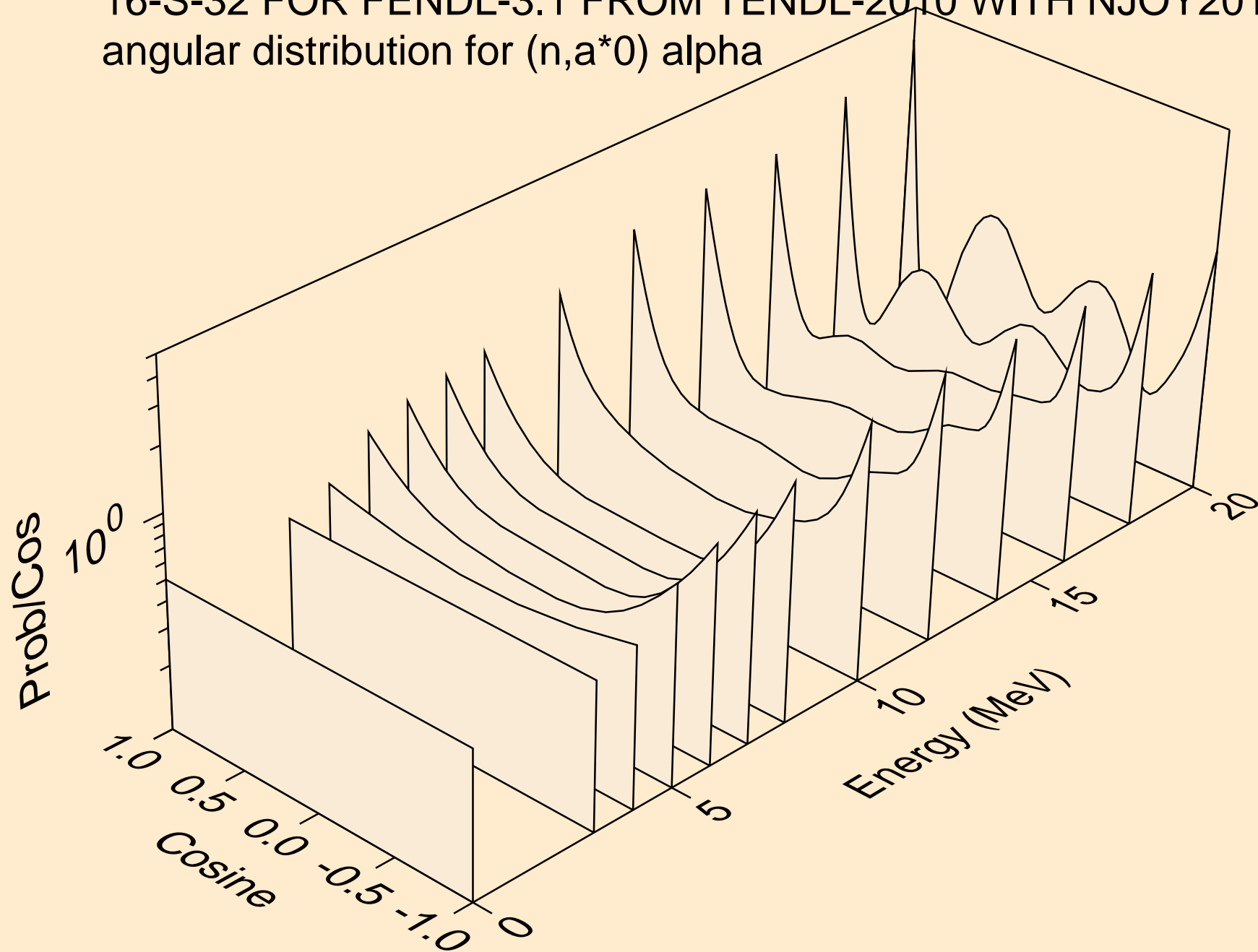

16-S-32 FOR FENDL-3.1 FROM TENDL-2010 WITH NJOY2012.50+
angular distribution for (n,a*1) alpha

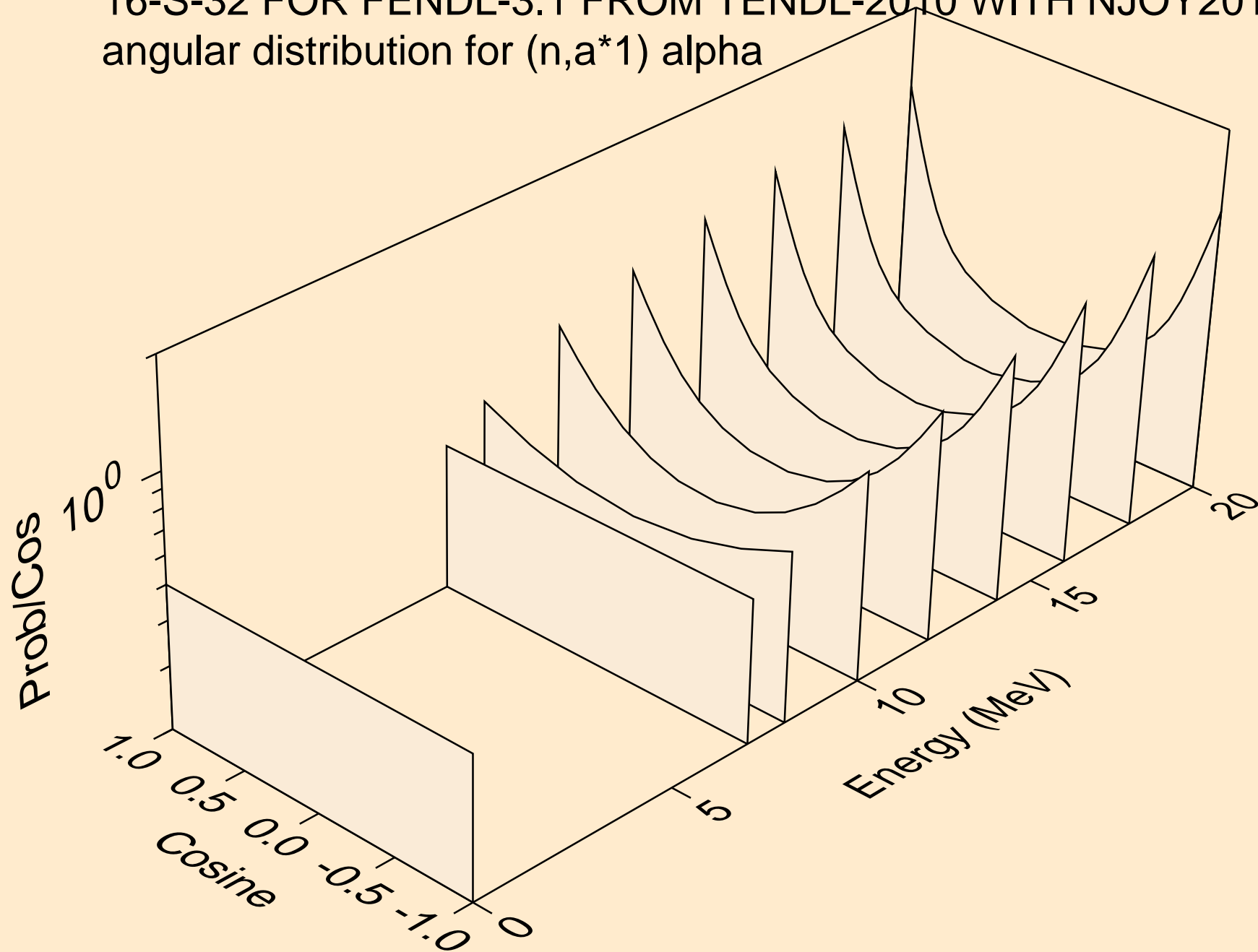

16-S-32 FOR FENDL-3.1 FROM TENDL-2010 WITH NJOY2012.50+
angular distribution for (n,a*2) alpha

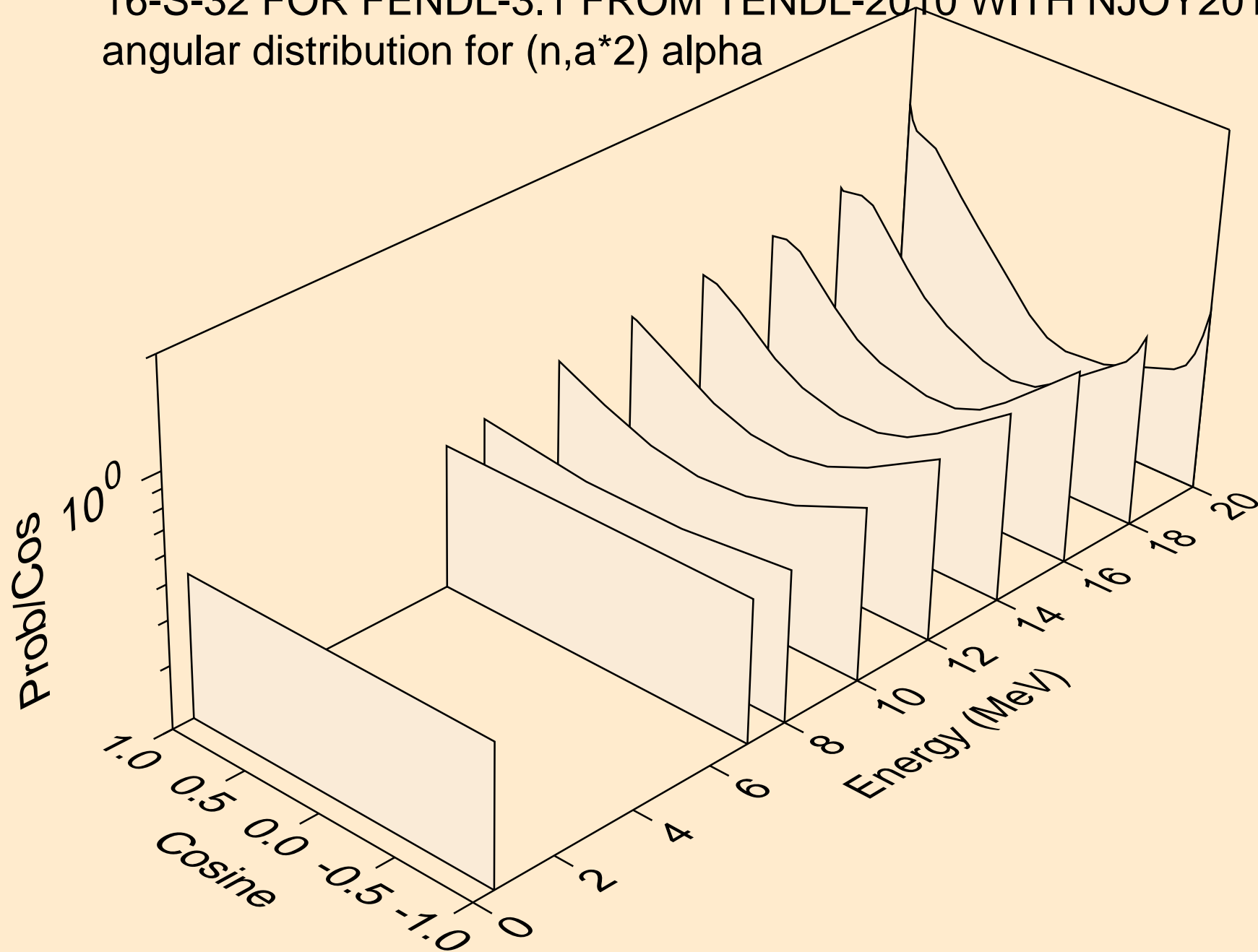

16-S-32 FOR FENDL-3.1 FROM TENDL-2010 WITH NJOY2012.50+
angular distribution for (n,a*3) alpha

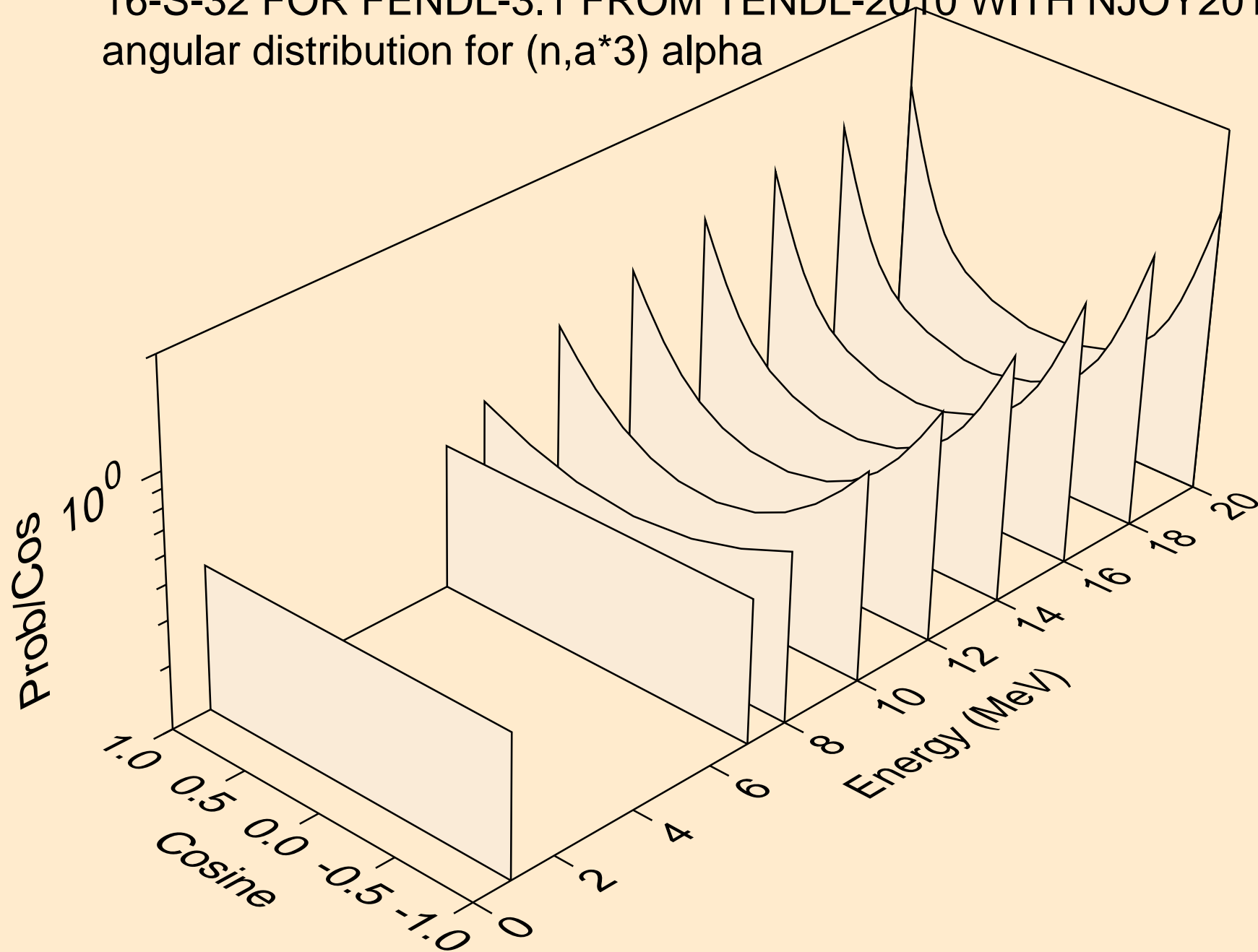

16-S-32 FOR FENDL-3.1 FROM TENDL-2010 WITH NJOY2012.50+
angular distribution for (n,a*4) alpha

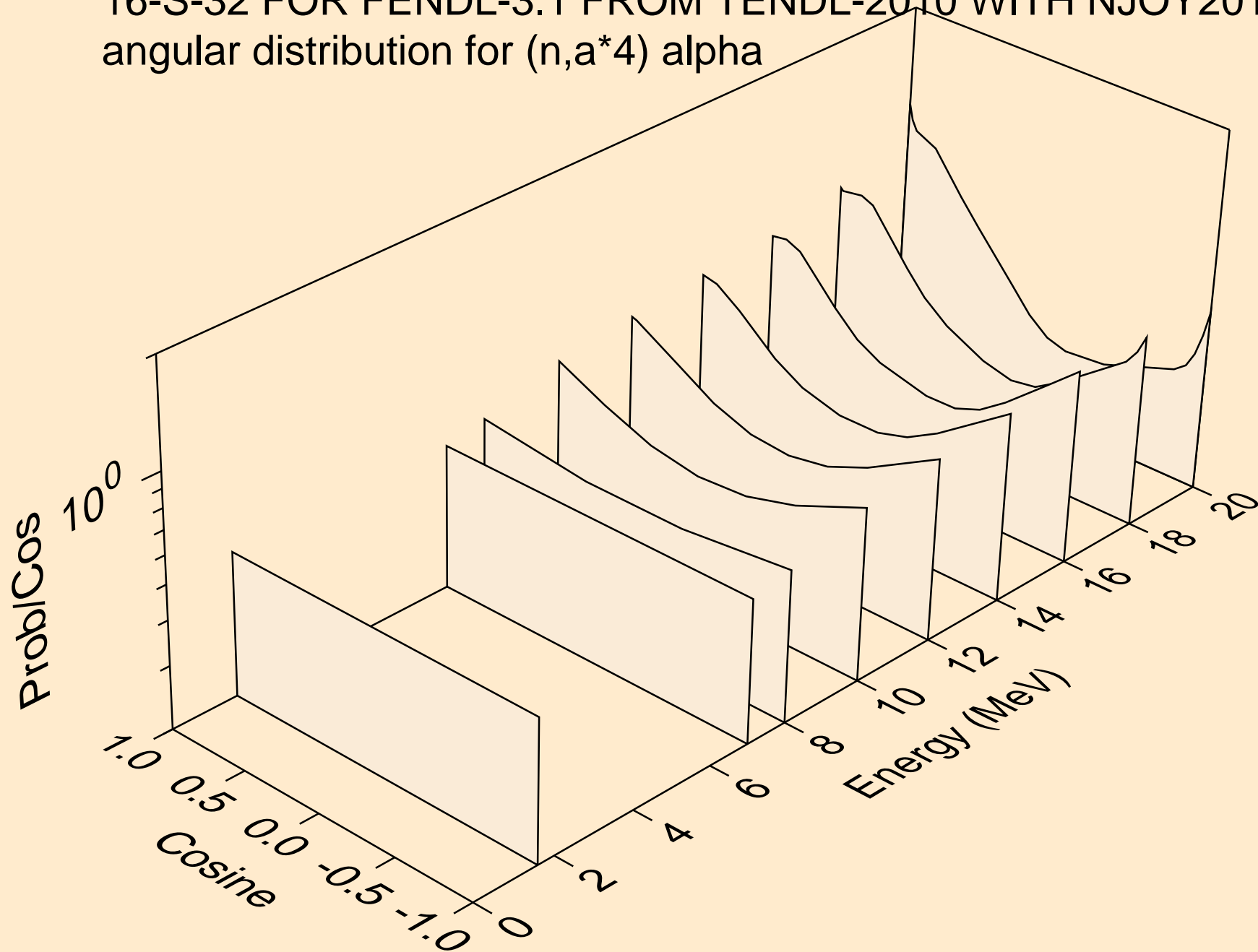

16-S-32 FOR FENDL-3.1 FROM TENDL-2010 WITH NJOY2012.50+
angular distribution for (n,a*5) alpha

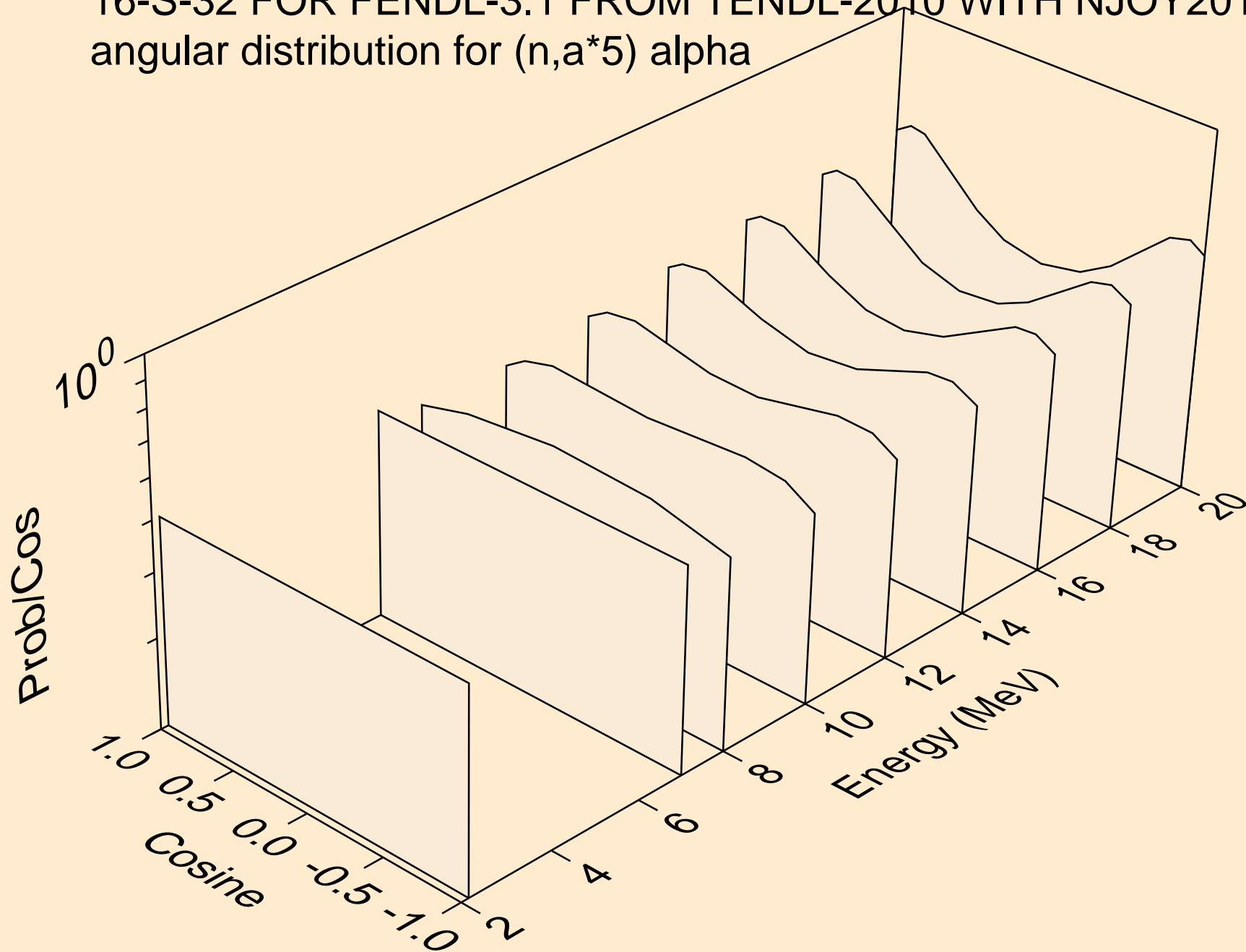

16-S-32 FOR FENDL-3.1 FROM TENDL-2010 WITH NJOY2012.50+
angular distribution for (n,a*6) alpha

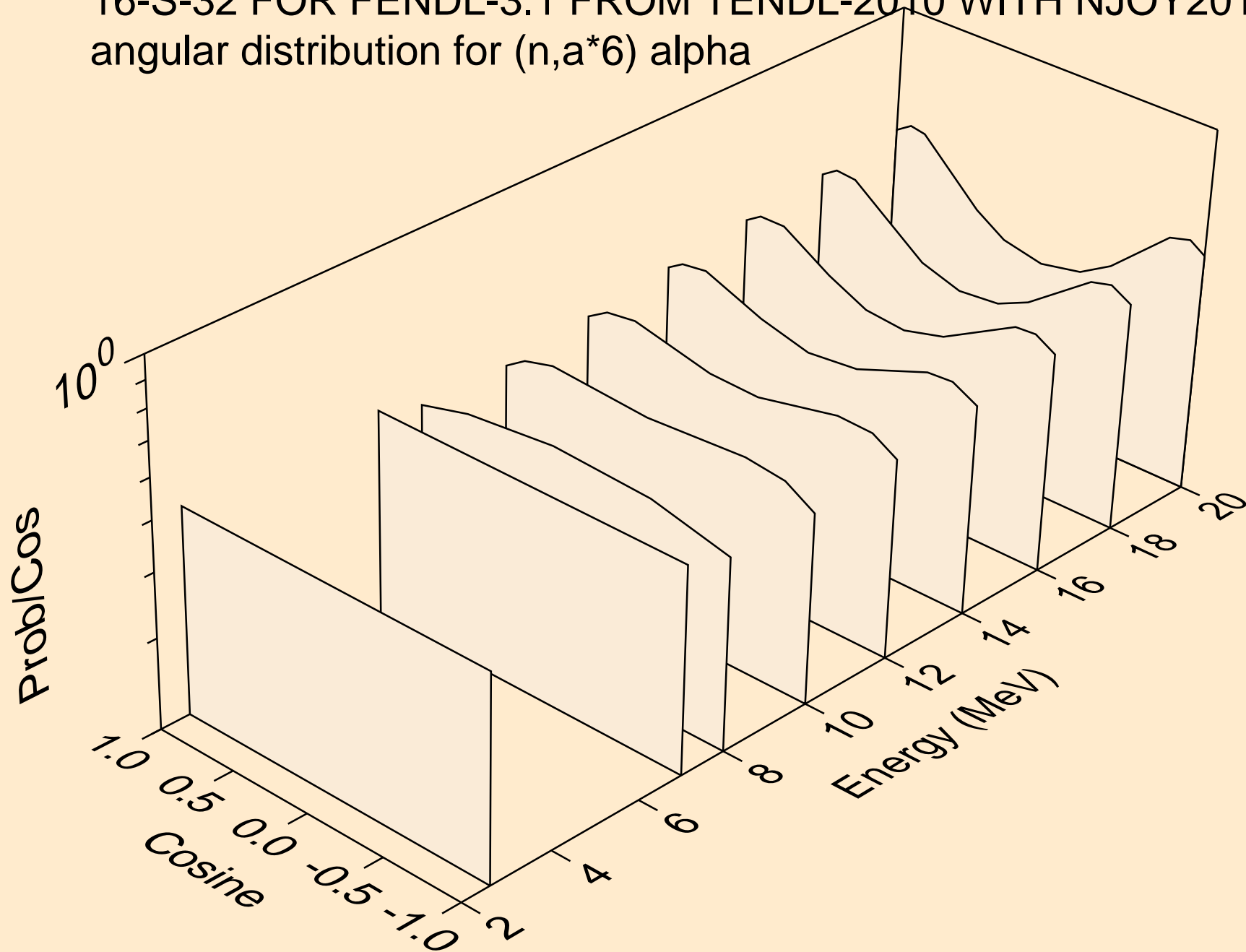

16-S-32 FOR FENDL-3.1 FROM TENDL-2010 WITH NJOY2012.50+
angular distribution for (n,a*7) alpha

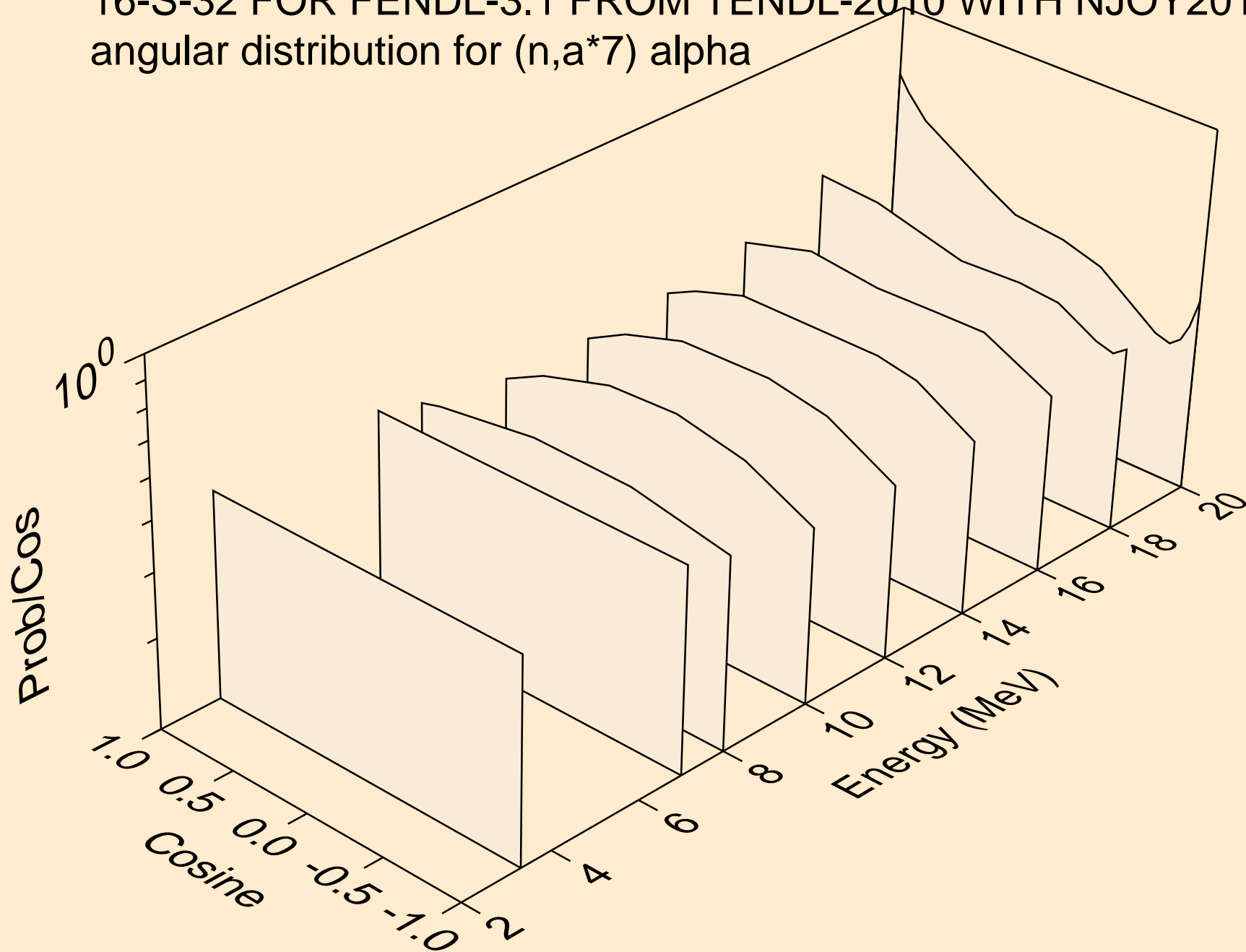

16-S-32 FOR FENDL-3.1 FROM TENDL-2010 WITH NJOY2012.50+
angular distribution for (n,a*8) alpha

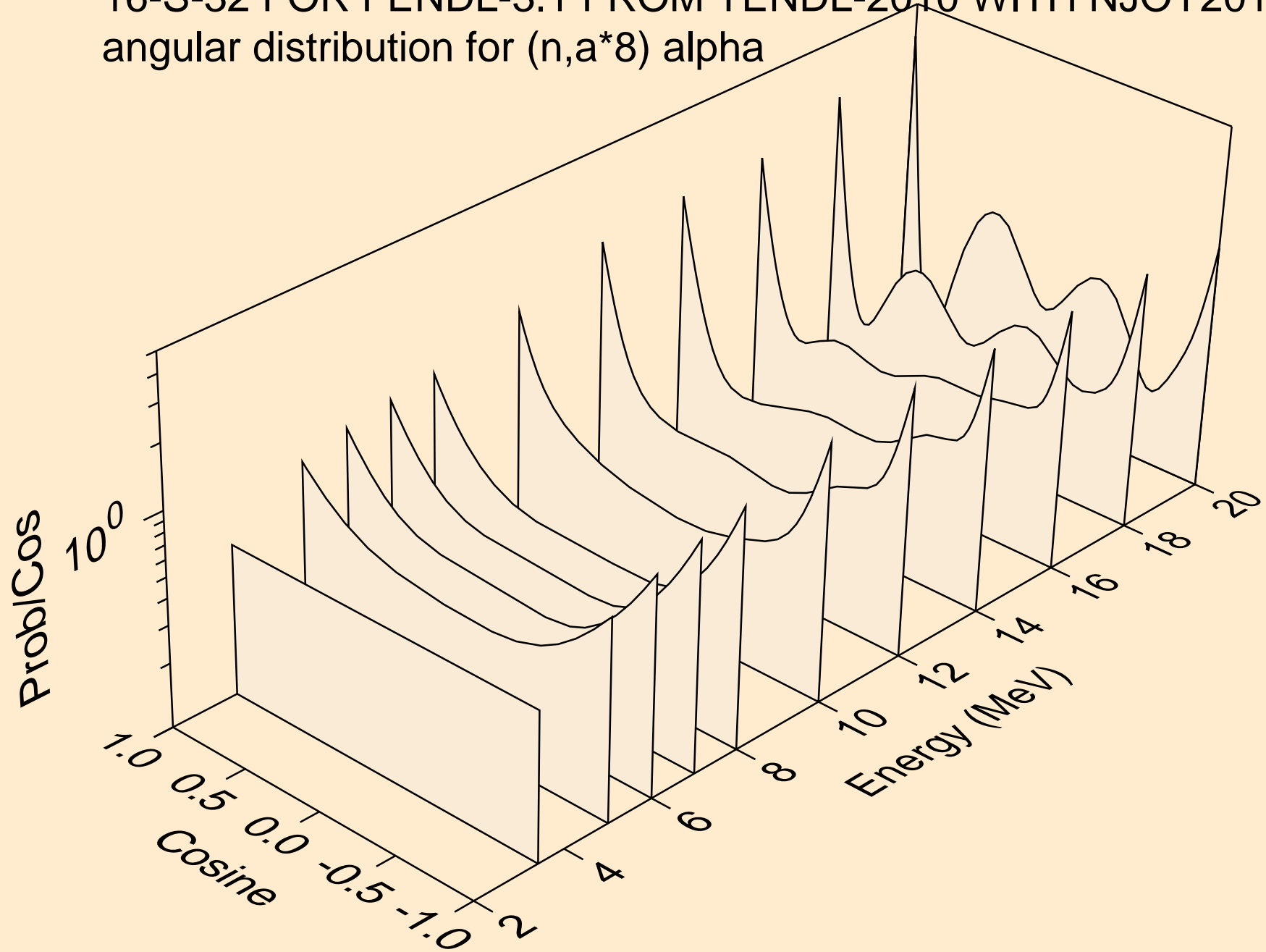

16-S-32 FOR FENDL-3.1 FROM TENDL-2010 WITH NJOY2012.50+
angular distribution for (n,a*9) alpha

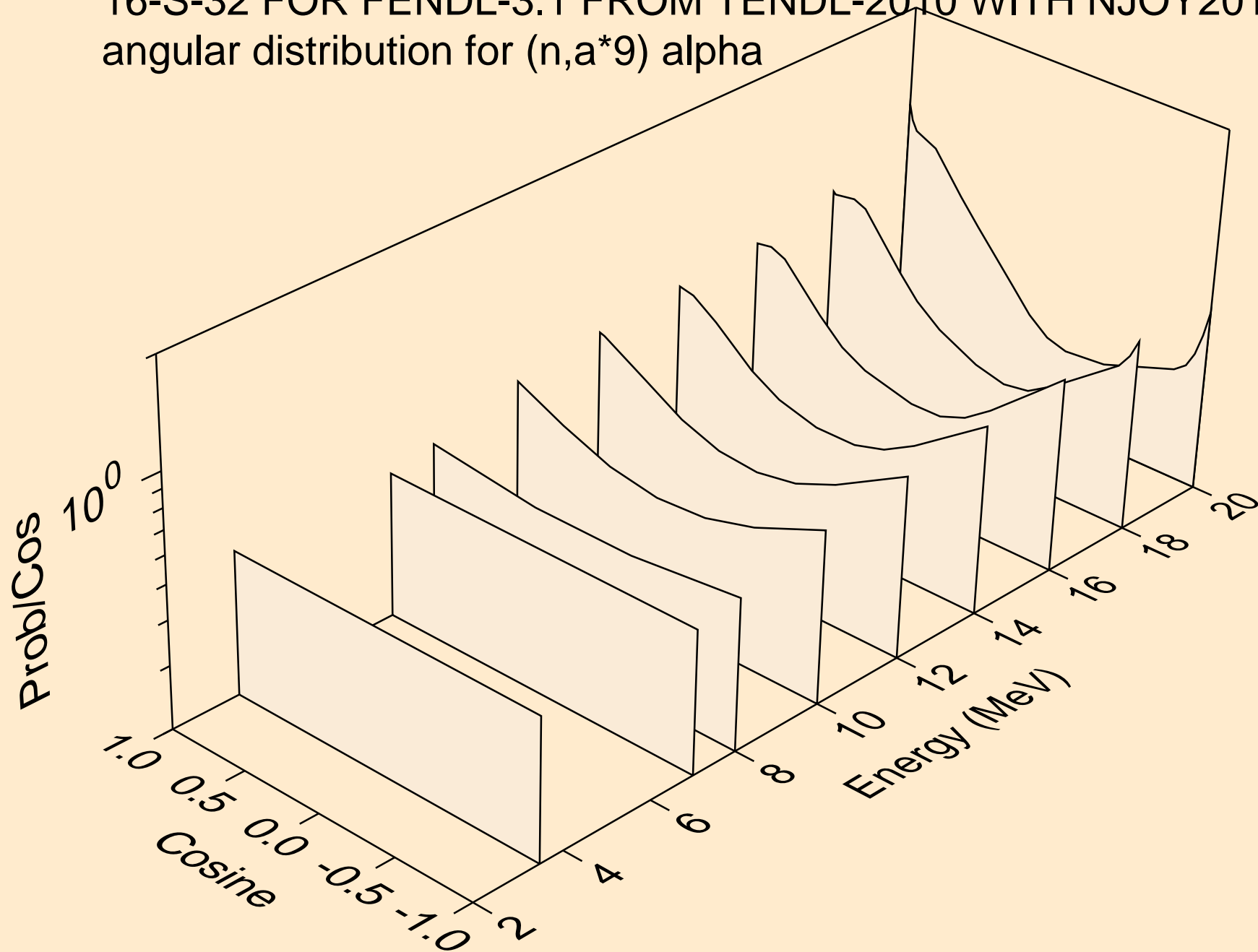

16-S-32 FOR FENDL-3.1 FROM TENDL-2010 WITH NJOY2012.50+
alphas from (n,a*c)

