

16-S-34 FOR FENDL-3.1 FROM TENDL-2010 WITH NJOY2012.50+

Principal cross sections

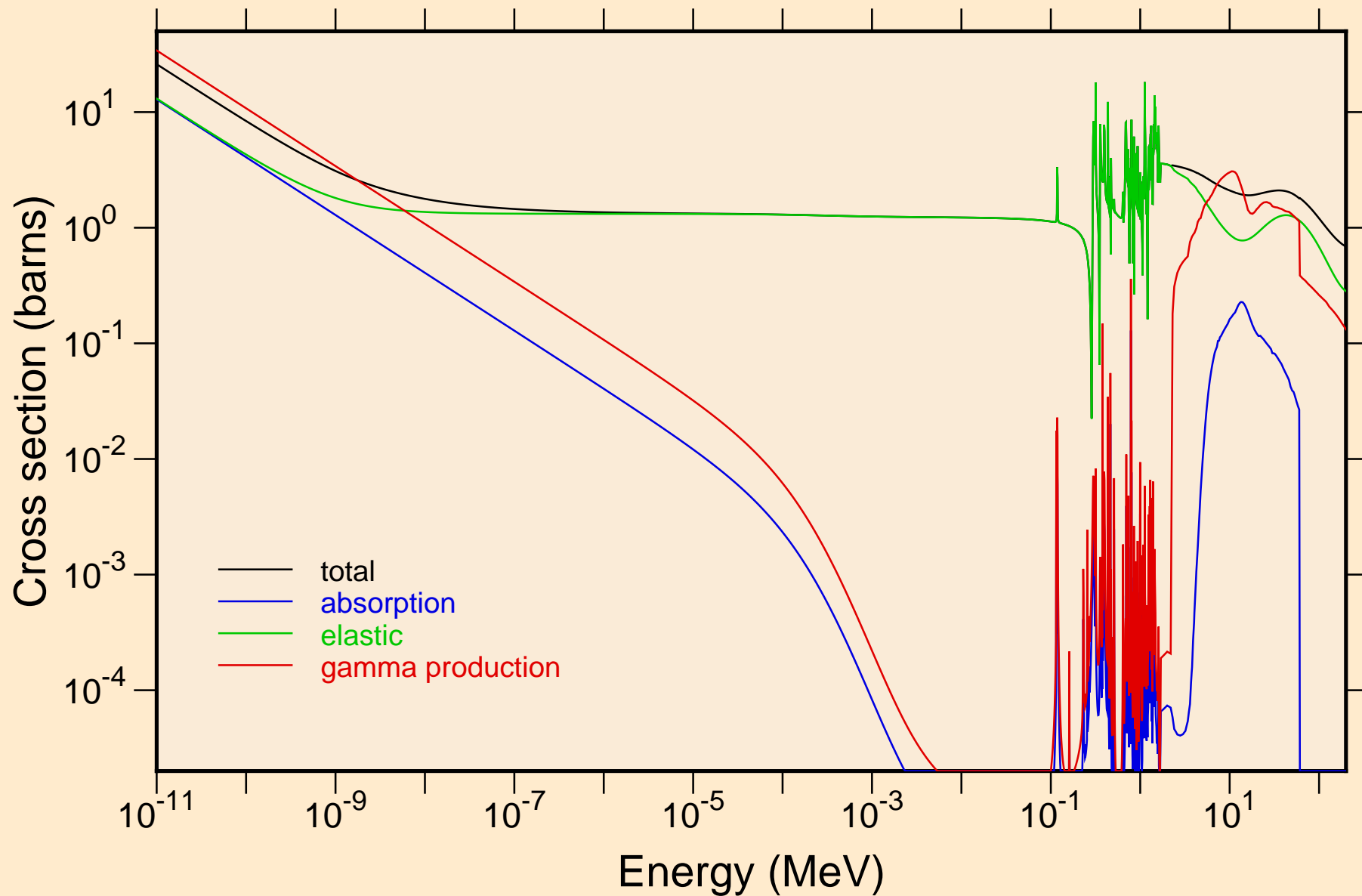

16-S-34 FOR FENDL-3.1 FROM TENDL-2010 WITH NJOY2012.50+
resonance total cross section

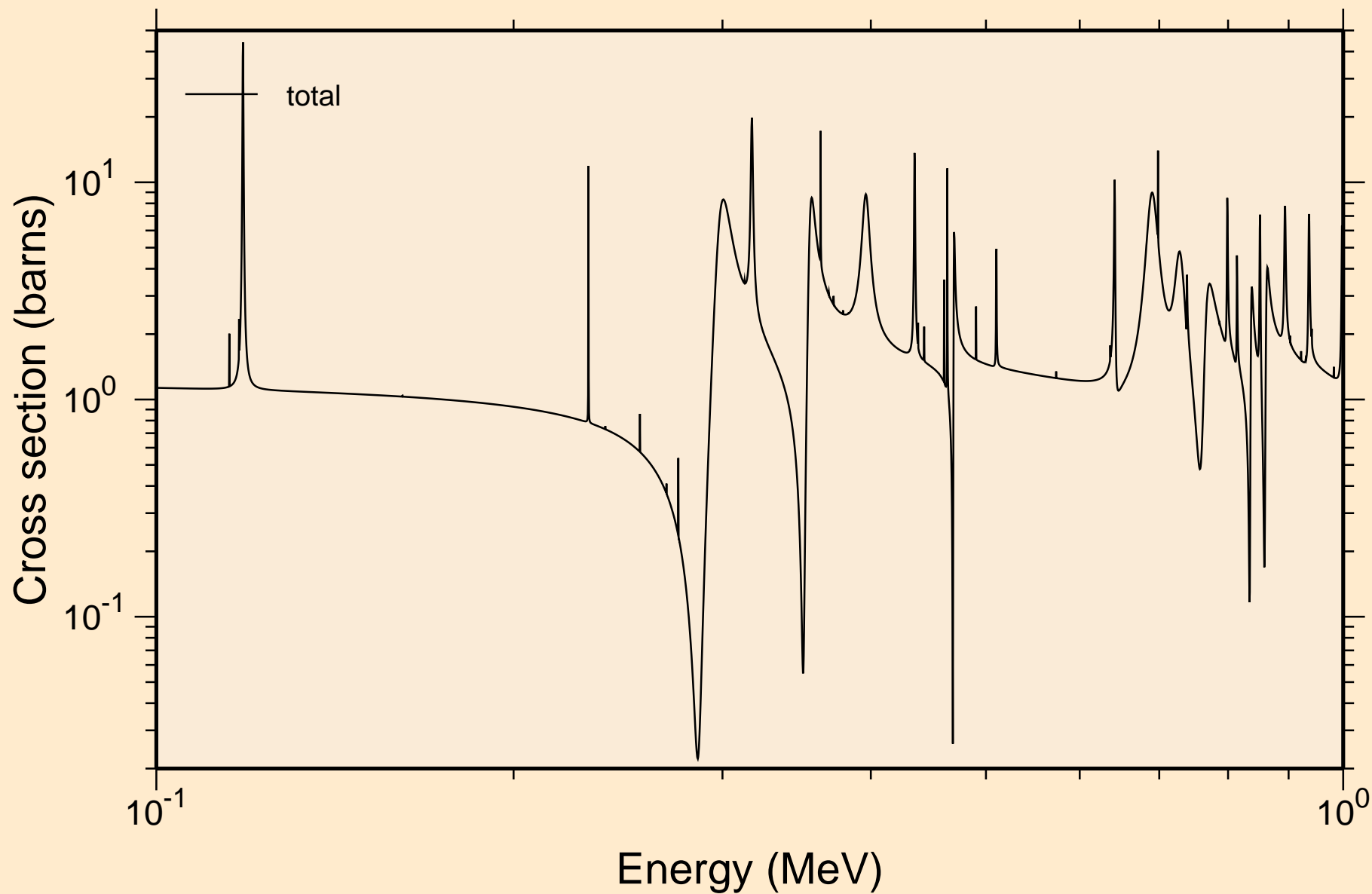

16-S-34 FOR FENDL-3.1 FROM TENDL-2010 WITH NJOY2012.50+
resonance total cross section

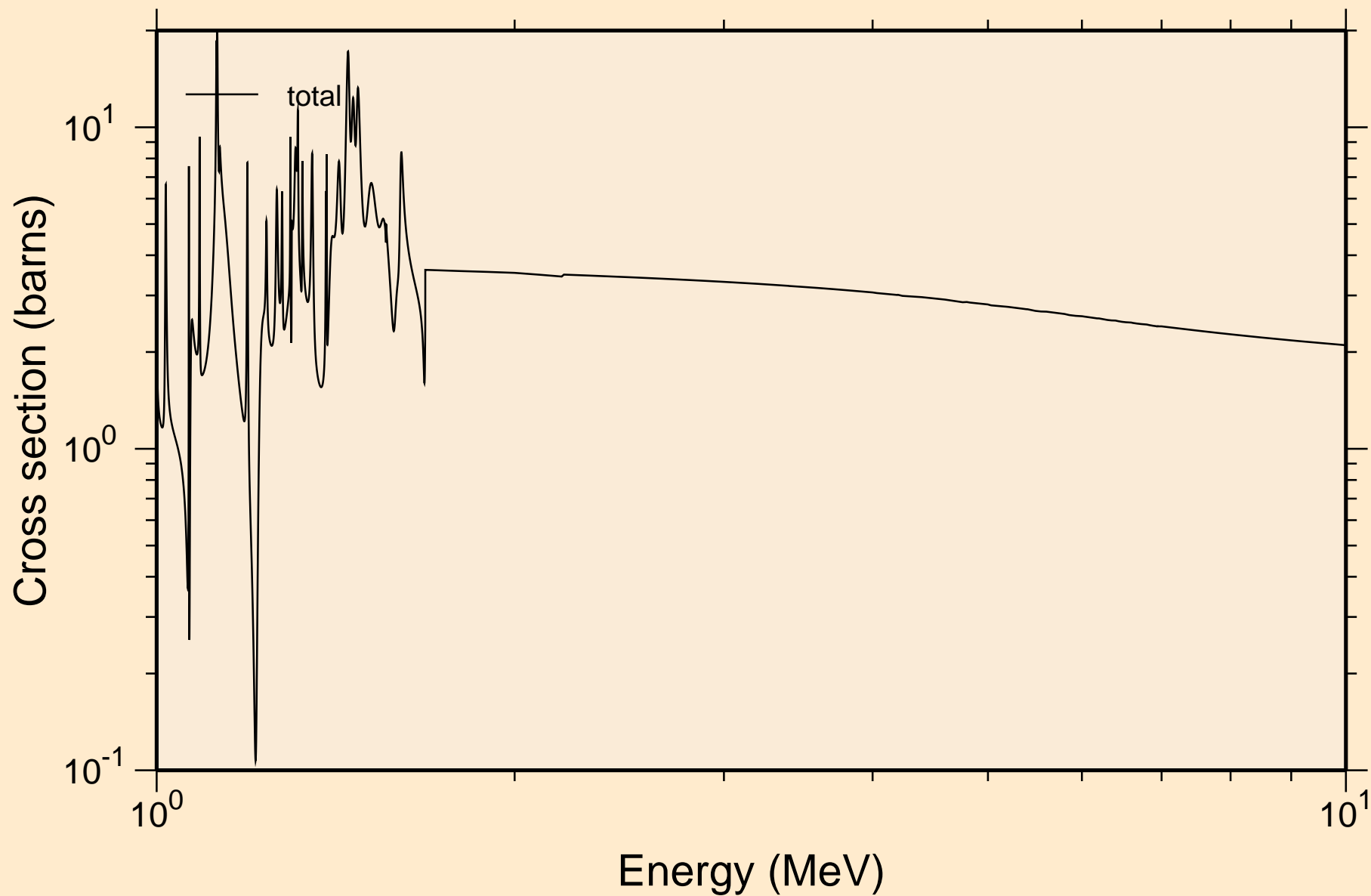

16-S-34 FOR FENDL-3.1 FROM TENDL-2010 WITH NJOY2012.50+ resonance absorption cross sections

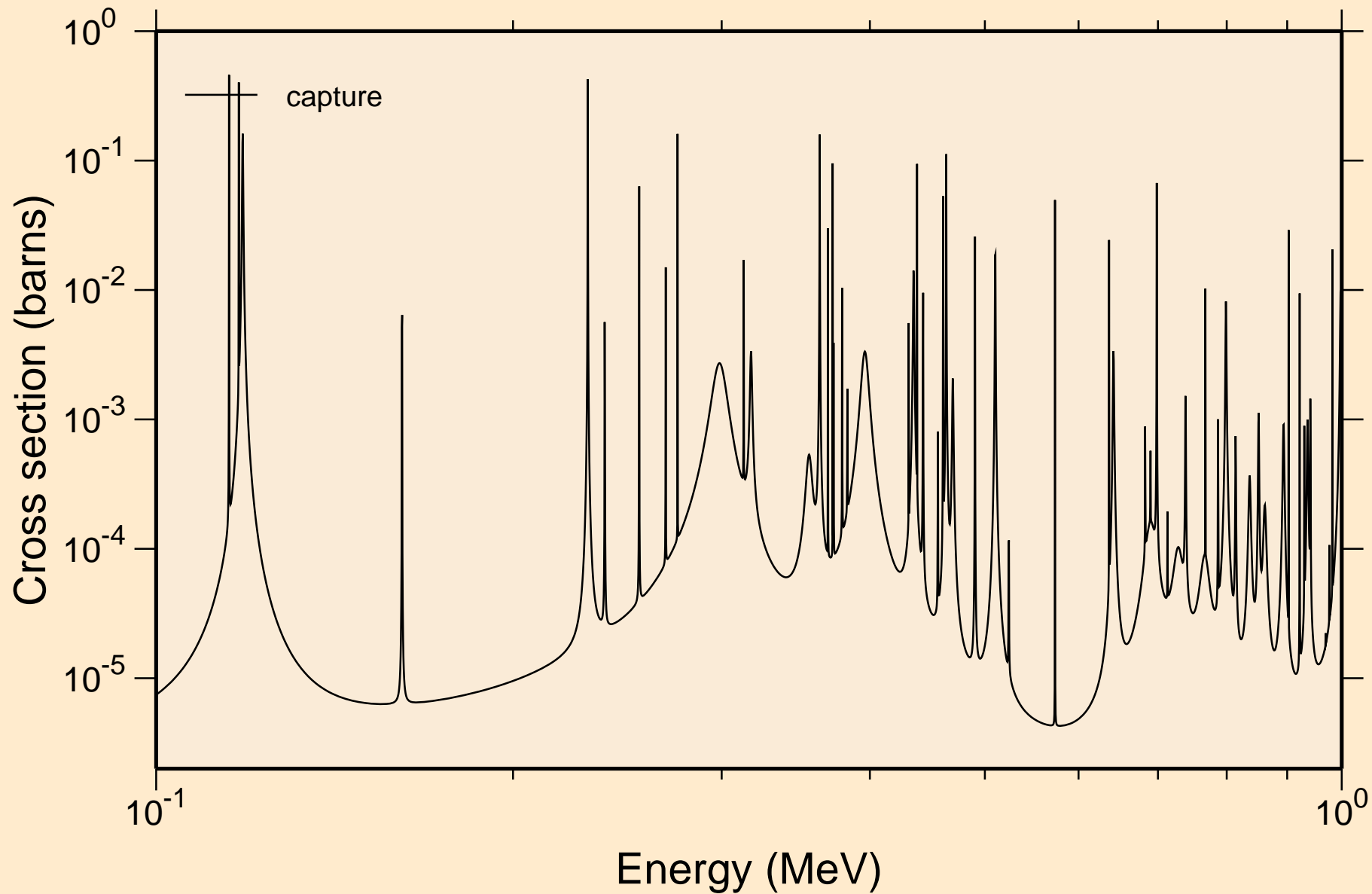

16-S-34 FOR FENDL-3.1 FROM TENDL-2010 WITH NJOY2012.50+
resonance absorption cross sections

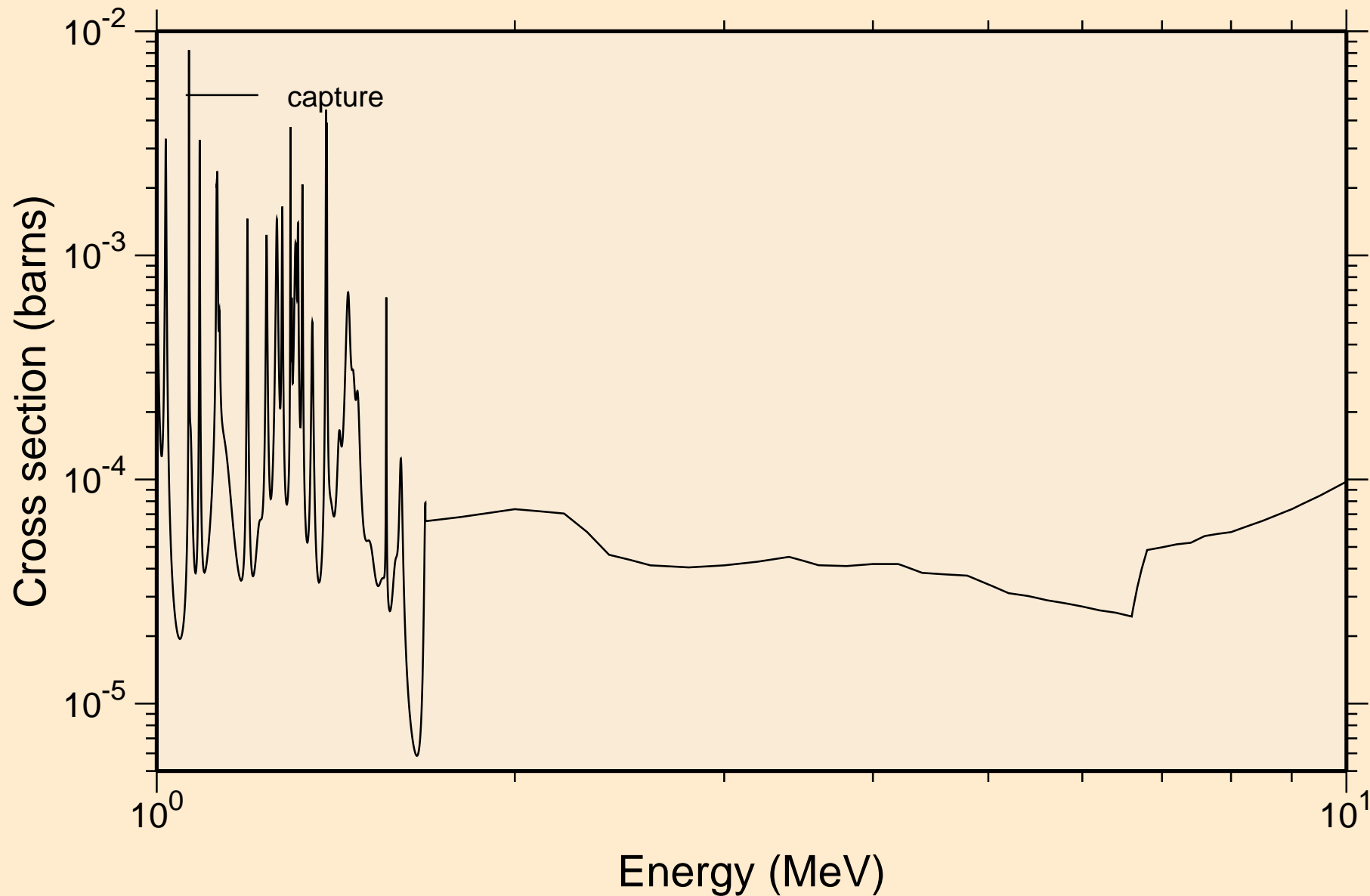

16-S-34 FOR FENDL-3.1 FROM TENDL-2010 WITH NJOY2012.50+
UR total cross section

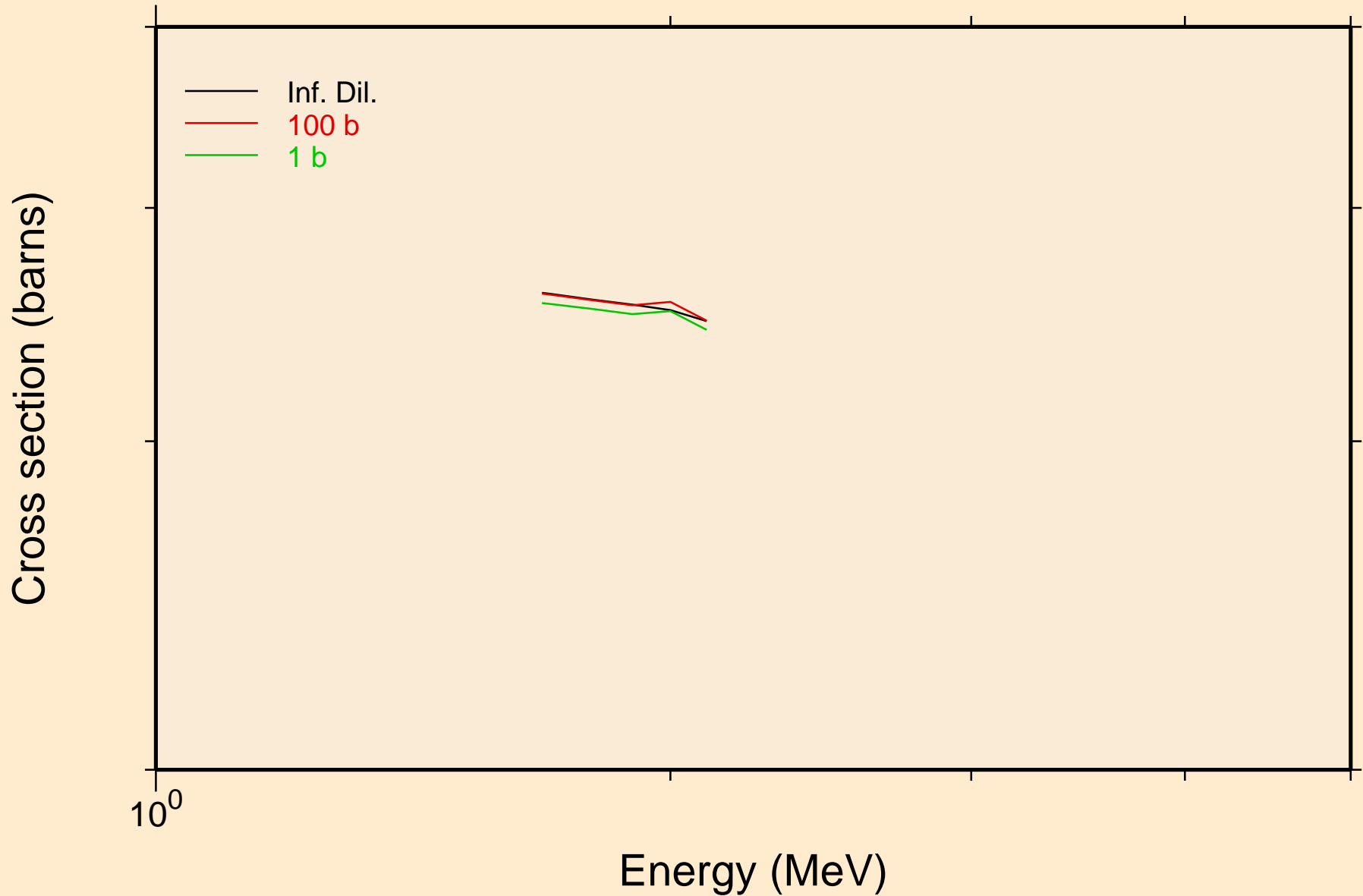

16-S-34 FOR FENDL-3.1 FROM TENDL-2010 WITH NJOY2012.50+
UR elastic cross section

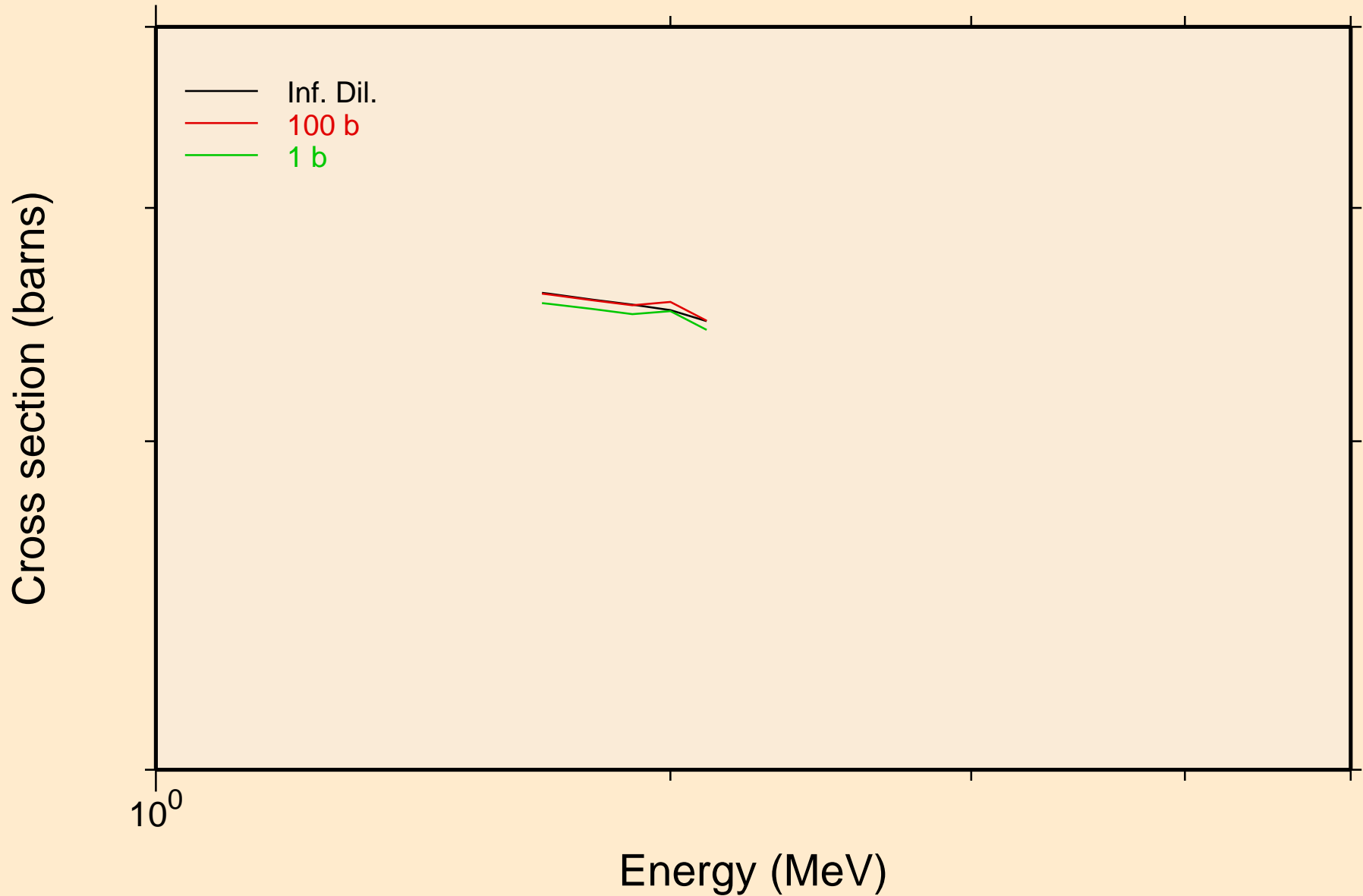

16-S-34 FOR FENDL-3.1 FROM TENDL-2010 WITH NJOY2012.50+
UR capture cross section

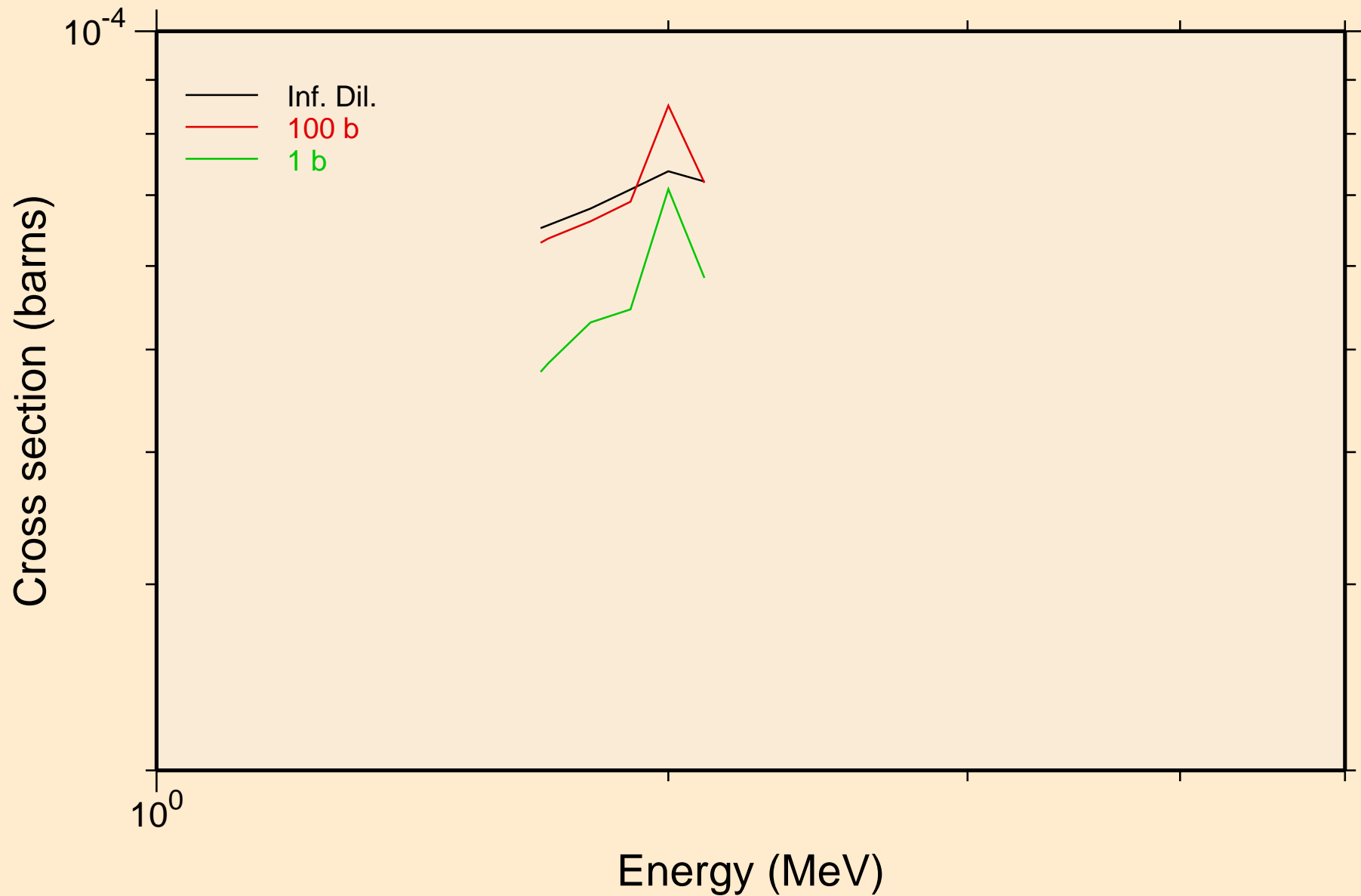

16-S-34 FOR FENDL-3.1 FROM TENDL-2010 WITH NJOY2012.50+ Heating

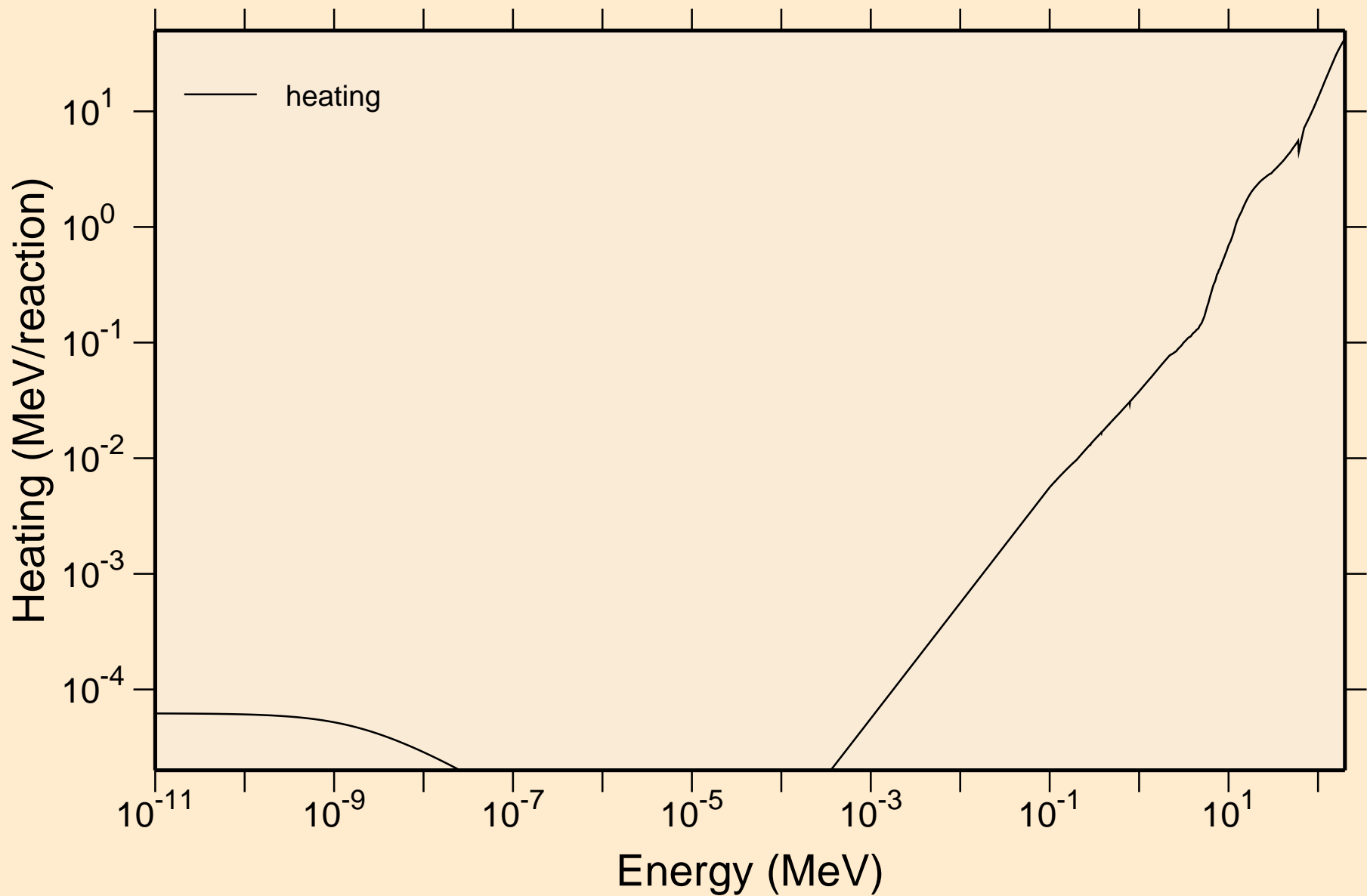

16-S-34 FOR FENDL-3.1 FROM TENDL-2010 WITH NJOY2012.50+ Damage

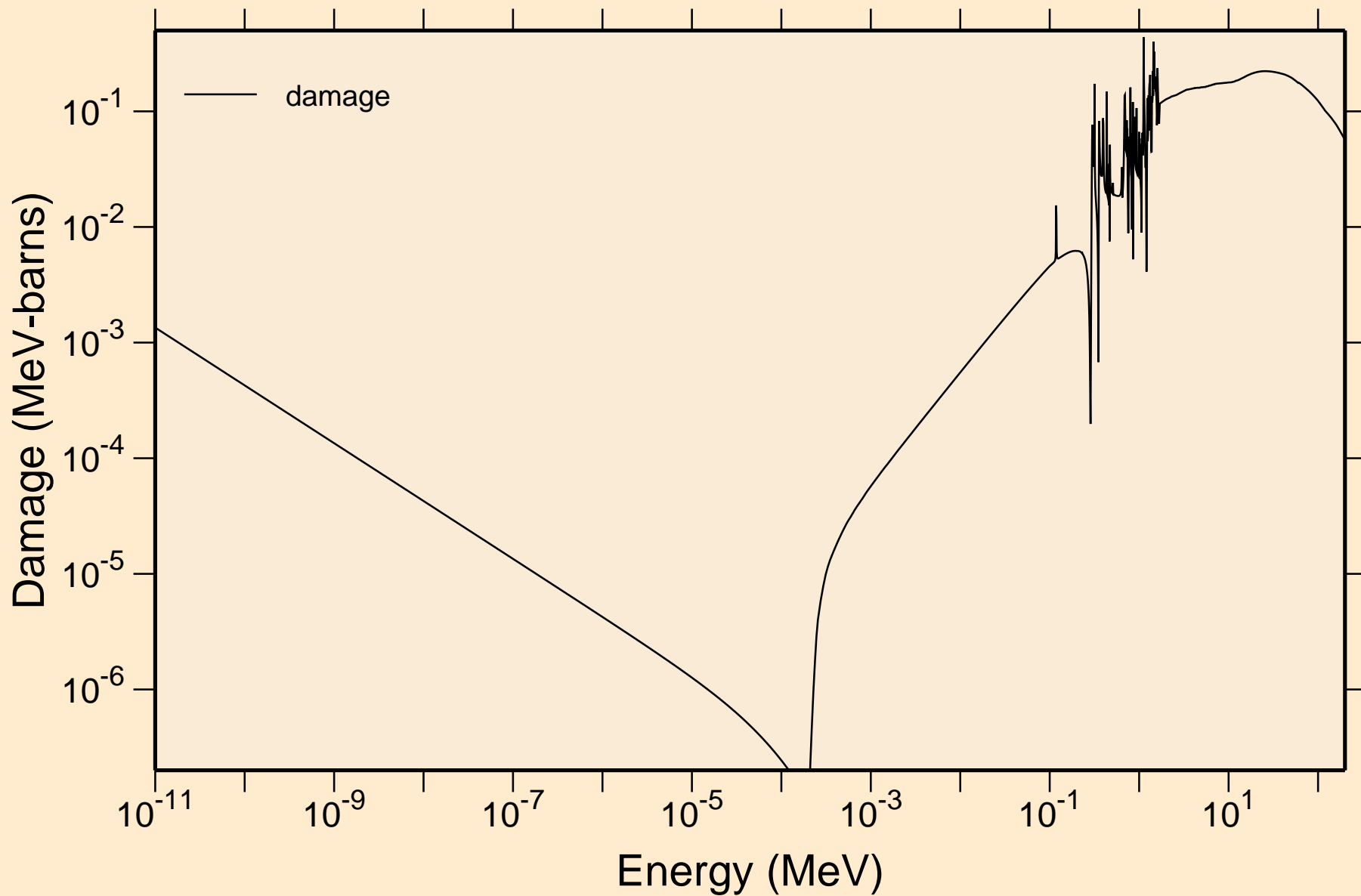

16-S-34 FOR FENDL-3.1 FROM TENDL-2010 WITH NJOY2012.50+
Non-threshold reactions

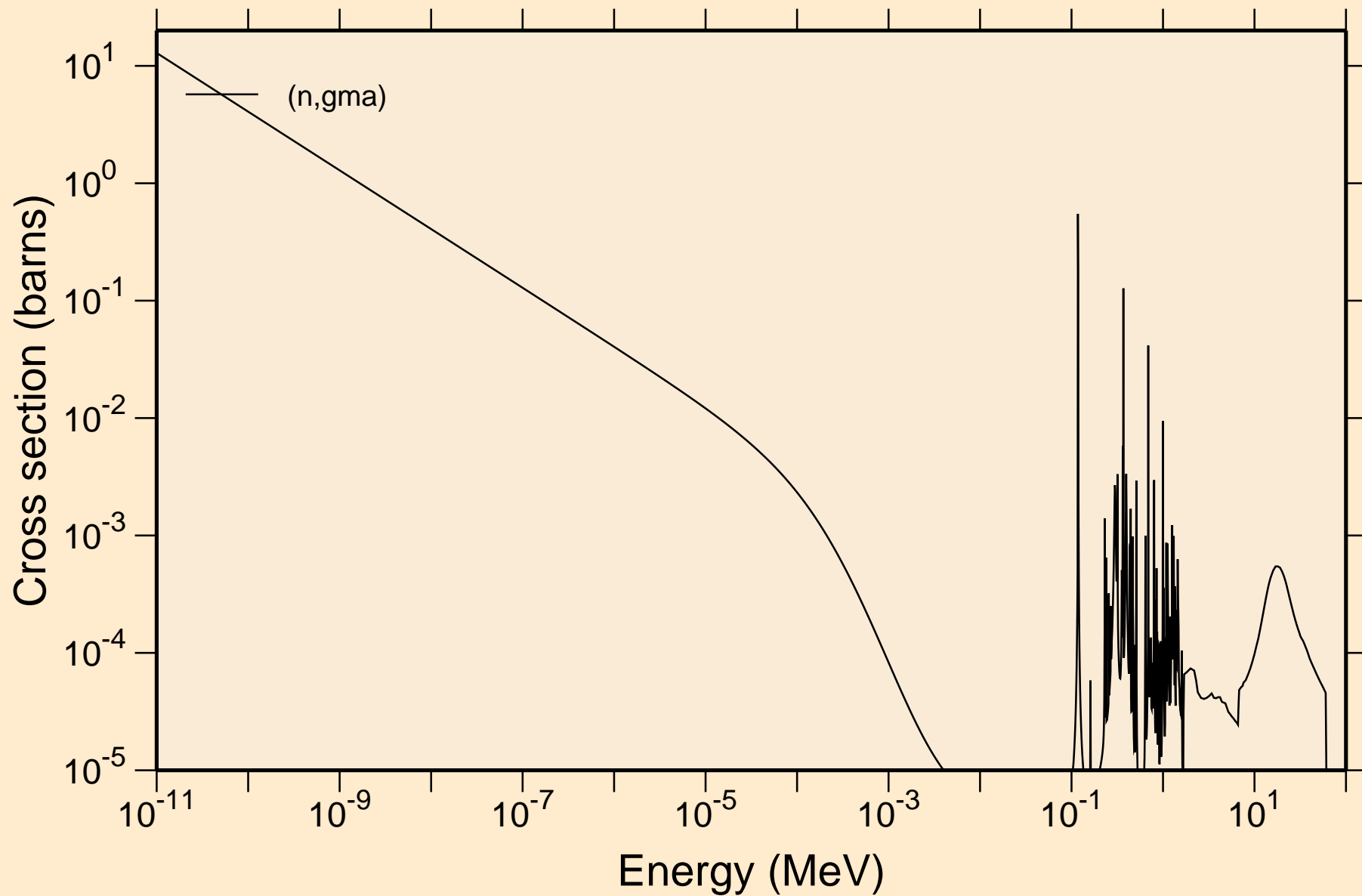

16-S-34 FOR FENDL-3.1 FROM TENDL-2010 WITH NJOY2012.50+

Principal cross sections

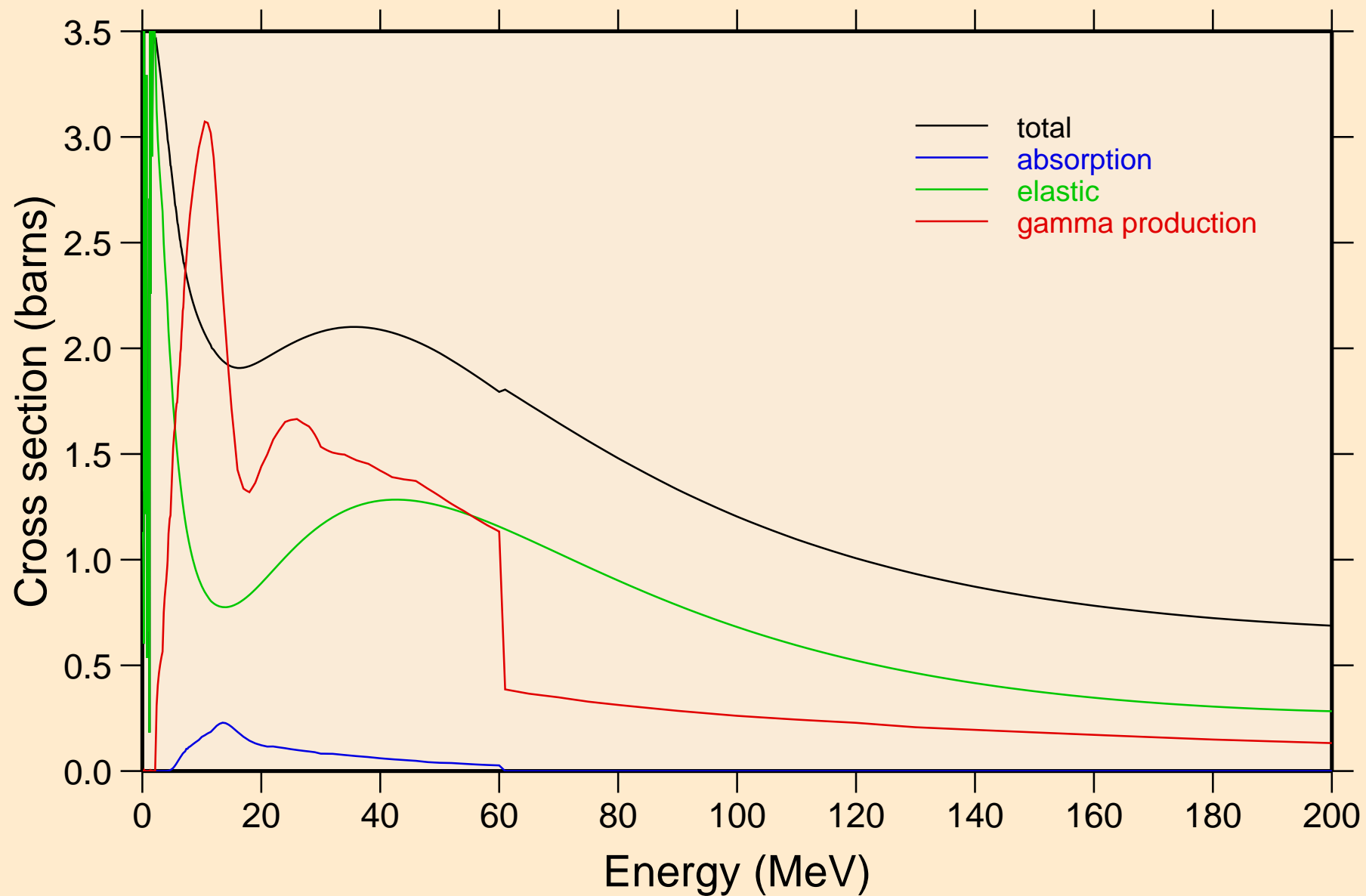

16-S-34 FOR FENDL-3.1 FROM TENDL-2010 WITH NJOY2012.50+ Heating

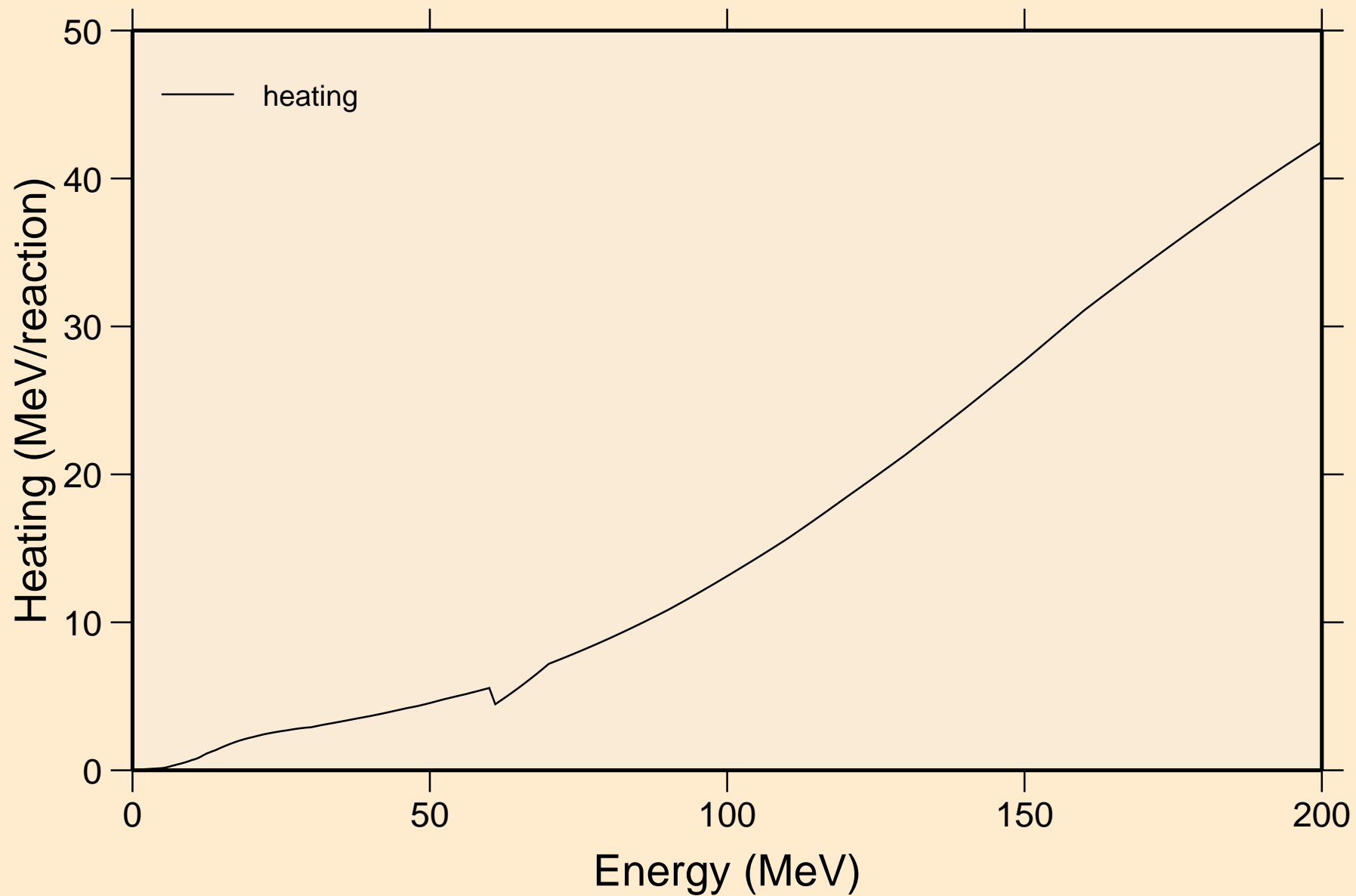

16-S-34 FOR FENDL-3.1 FROM TENDL-2010 WITH NJOY2012.50+ Damage

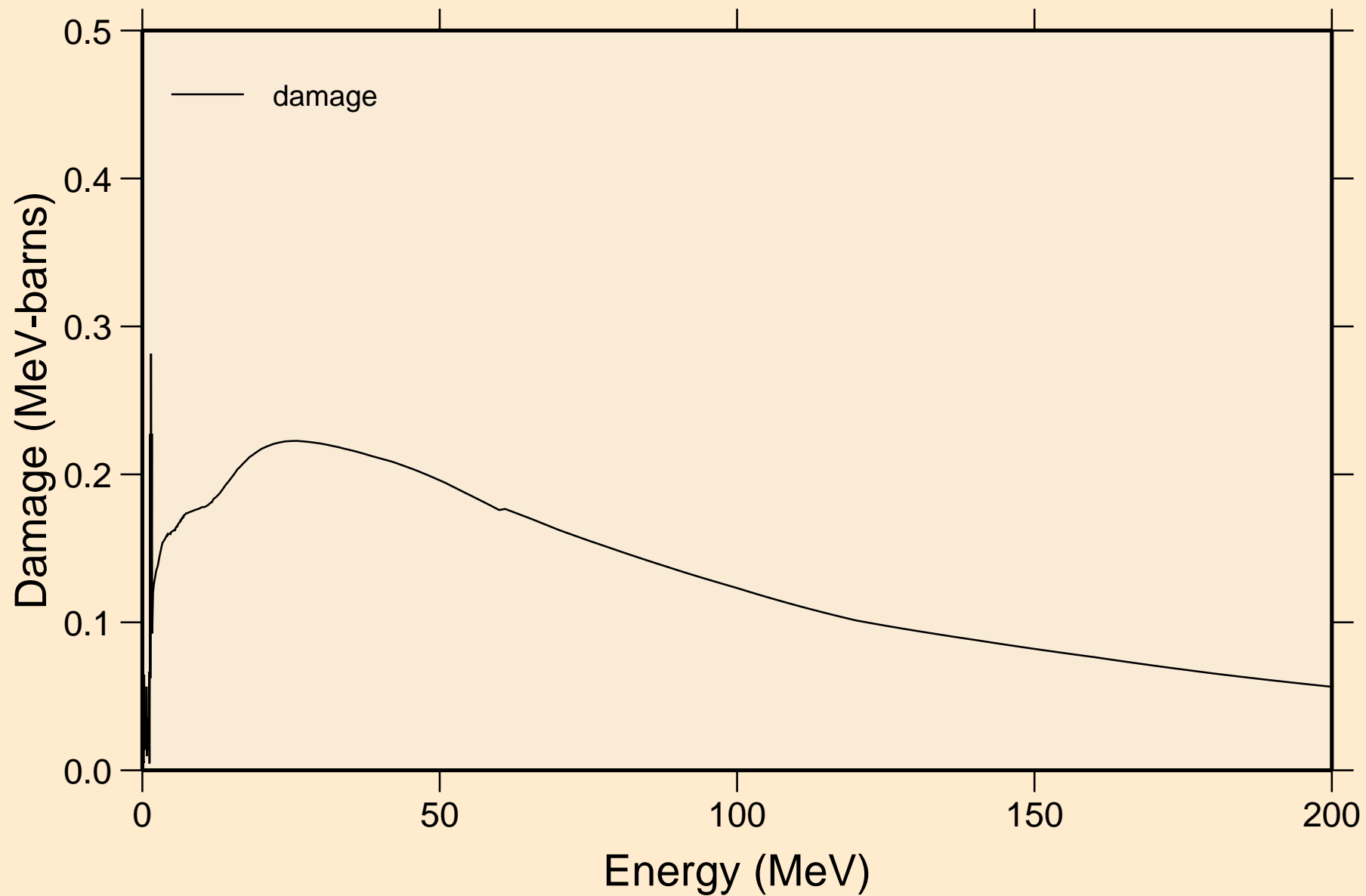

16-S-34 FOR FENDL-3.1 FROM TENDL-2010 WITH NJOY2012.50+
Non-threshold reactions

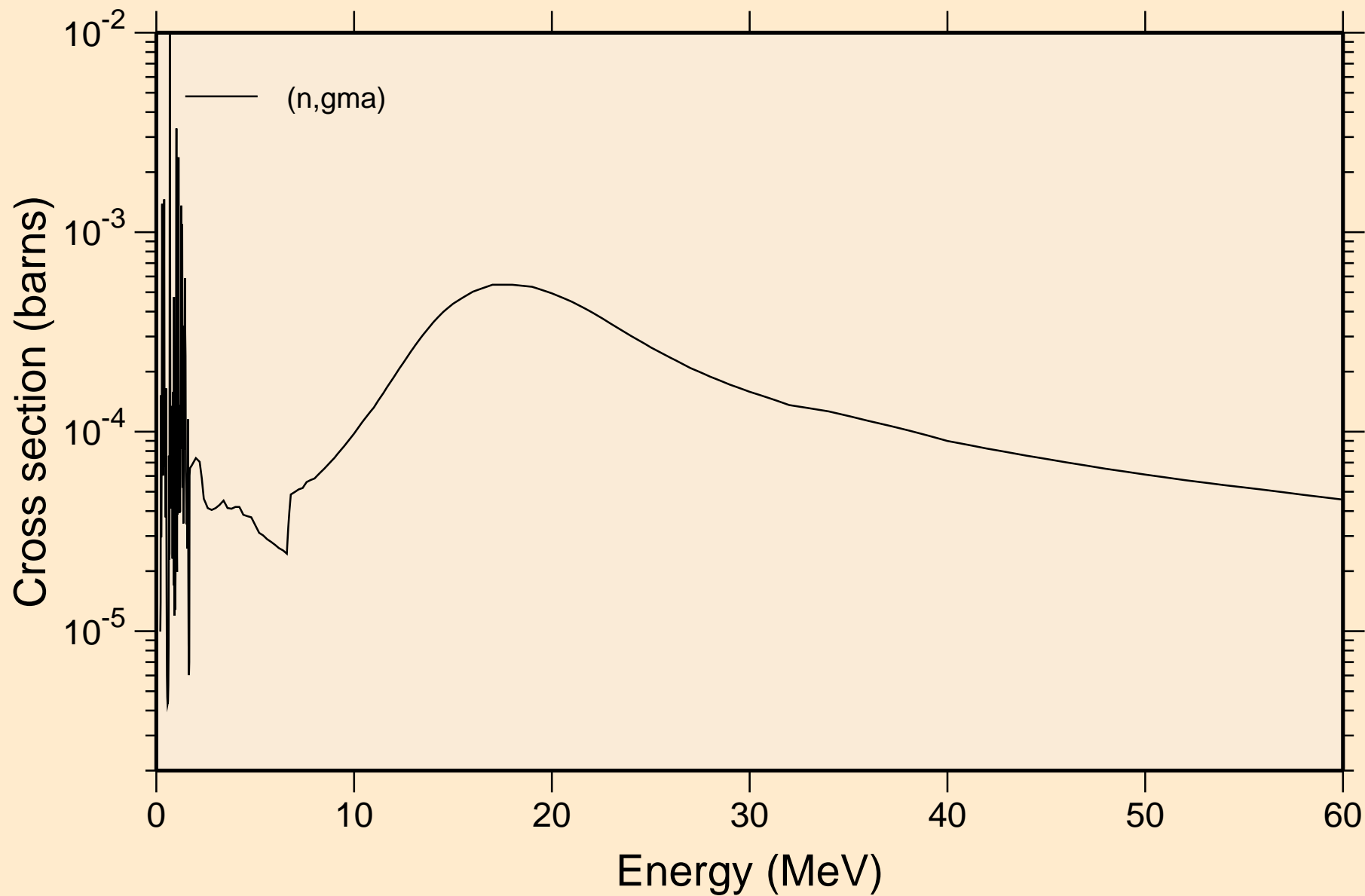

16-S-34 FOR FENDL-3.1 FROM TENDL-2010 WITH NJOY2012.50+

Inelastic levels

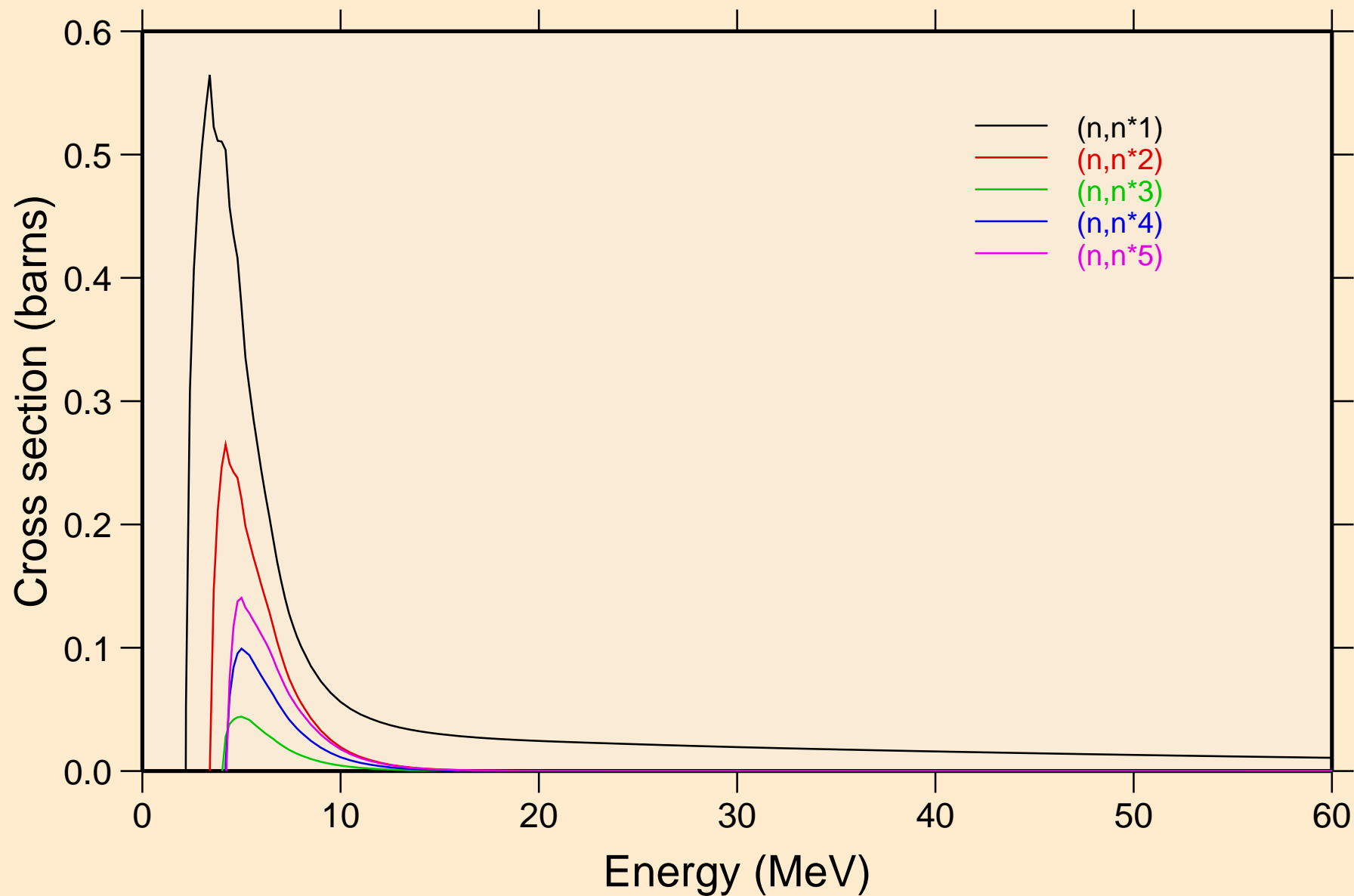

16-S-34 FOR FENDL-3.1 FROM TENDL-2010 WITH NJOY2012.50+

Inelastic levels

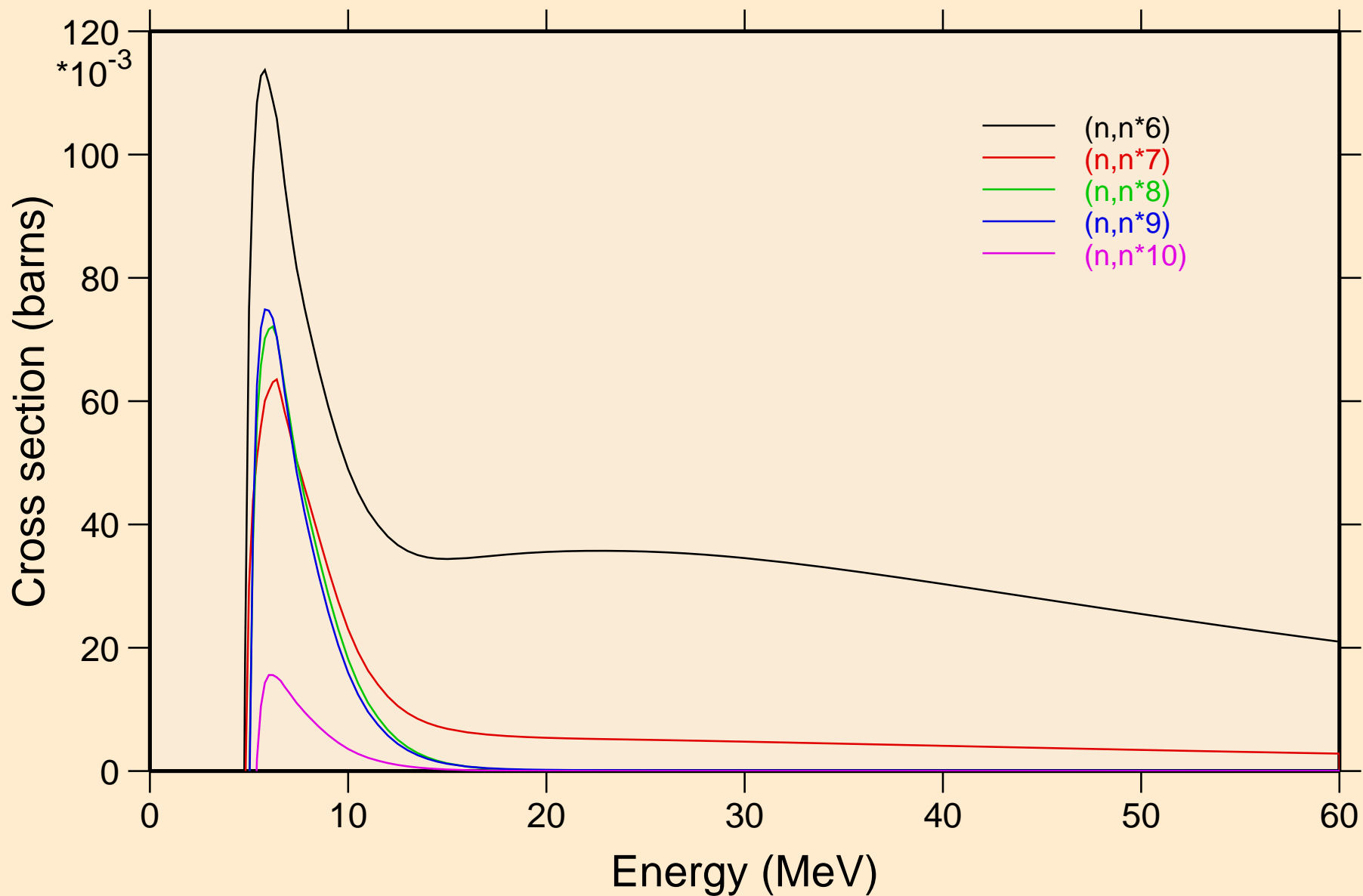

16-S-34 FOR FENDL-3.1 FROM TENDL-2010 WITH NJOY2012.50+

Inelastic levels

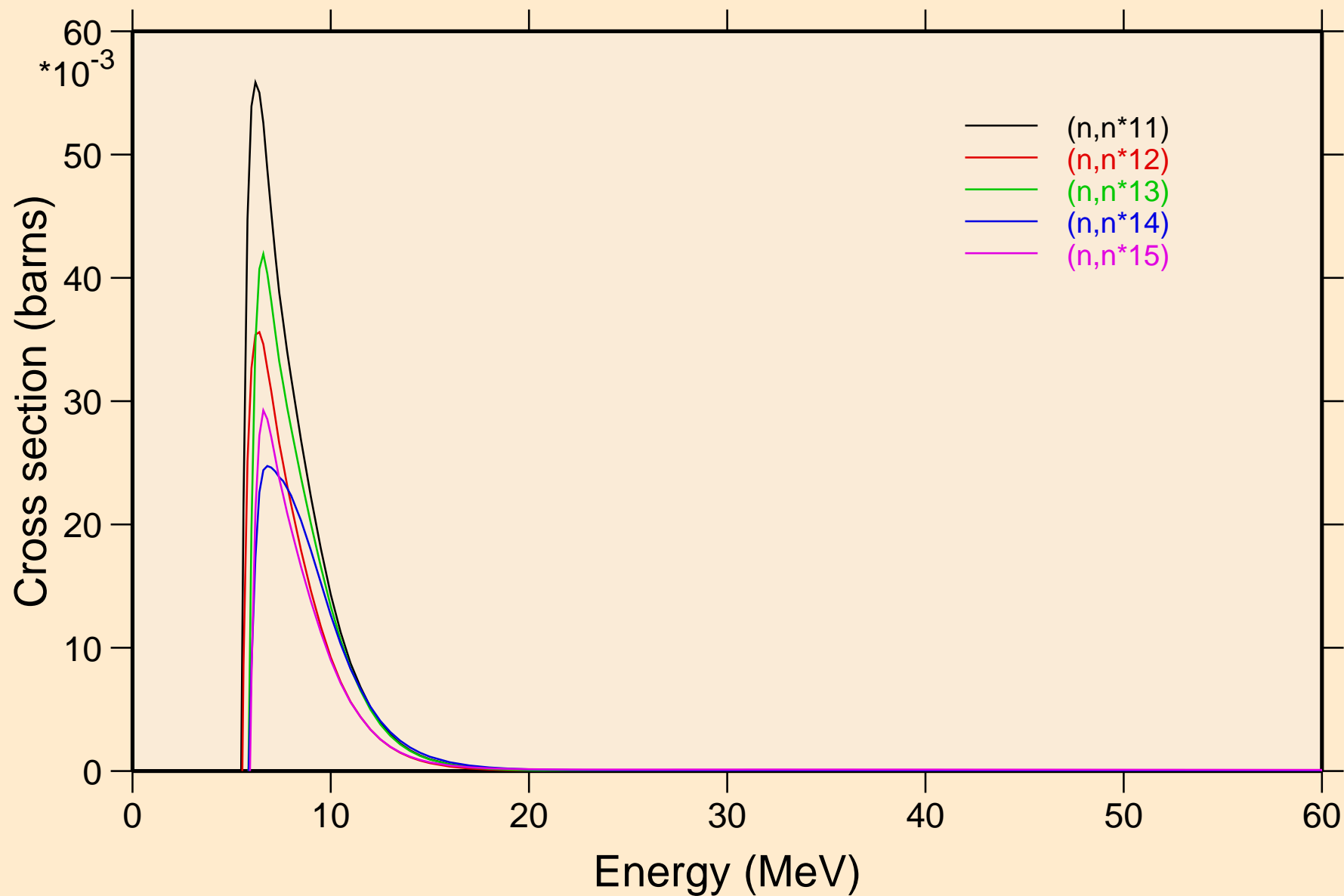

16-S-34 FOR FENDL-3.1 FROM TENDL-2010 WITH NJOY2012.50+

Inelastic levels

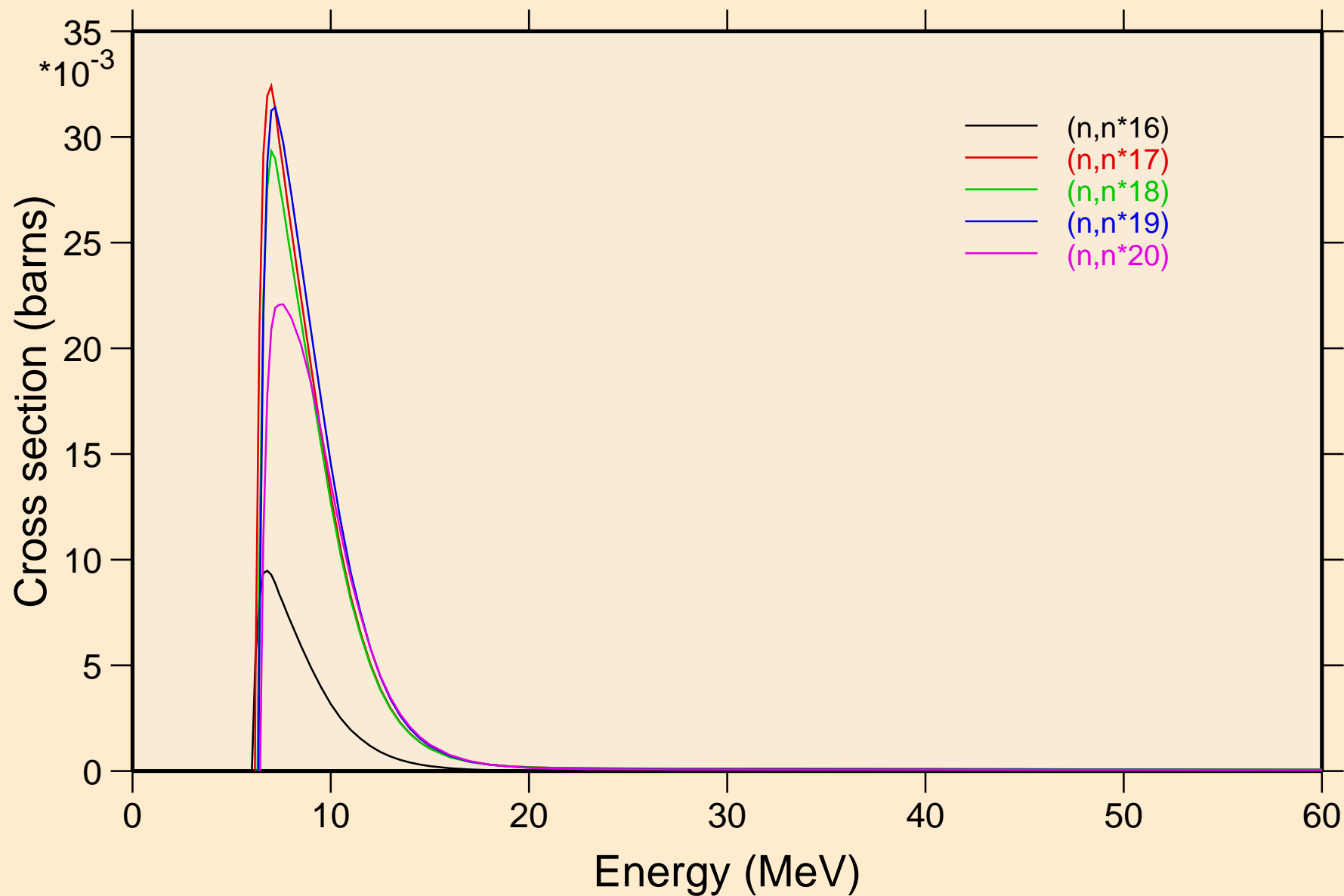

16-S-34 FOR FENDL-3.1 FROM TENDL-2010 WITH NJOY2012.50+

Inelastic levels

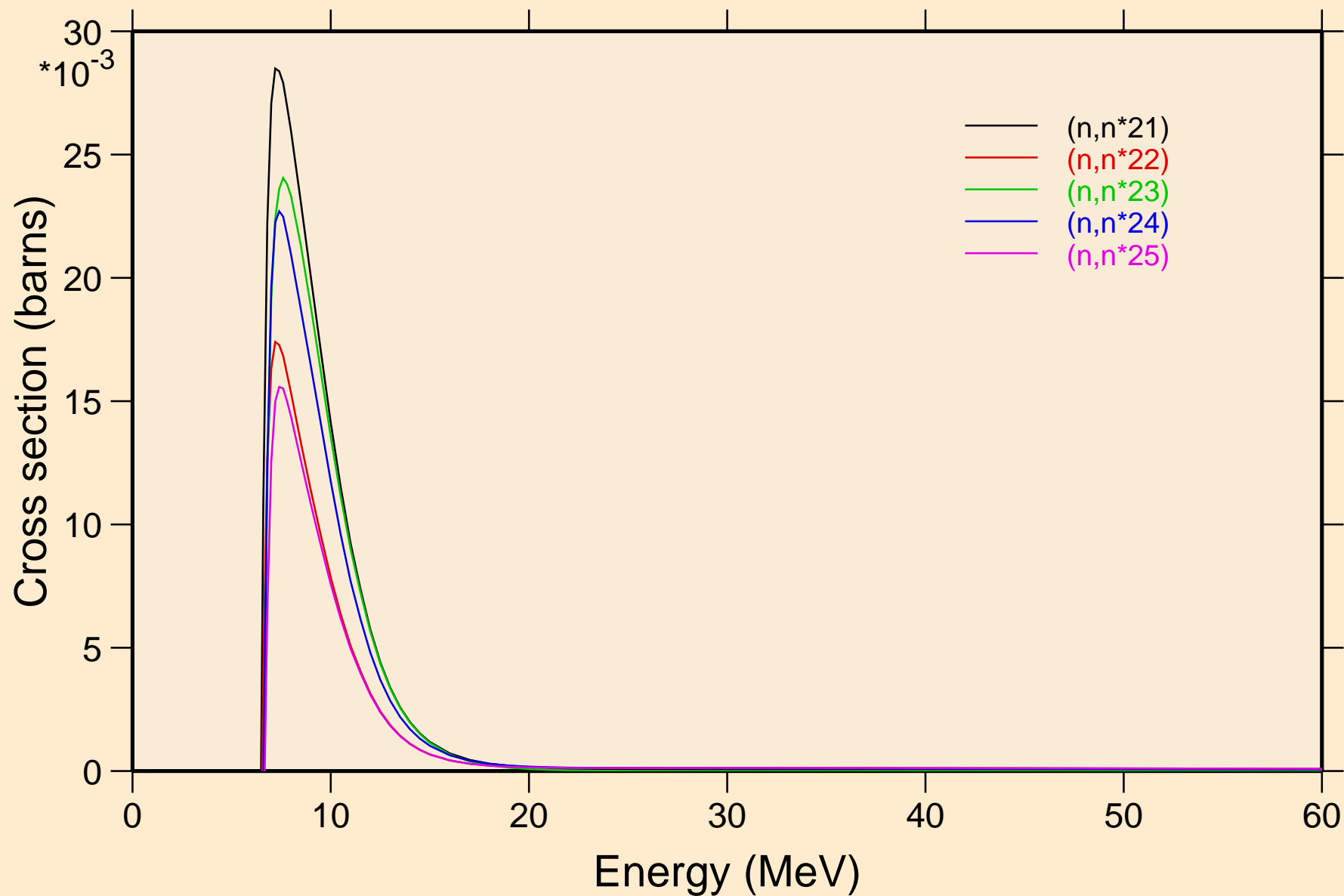

16-S-34 FOR FENDL-3.1 FROM TENDL-2010 WITH NJOY2012.50+

Inelastic levels

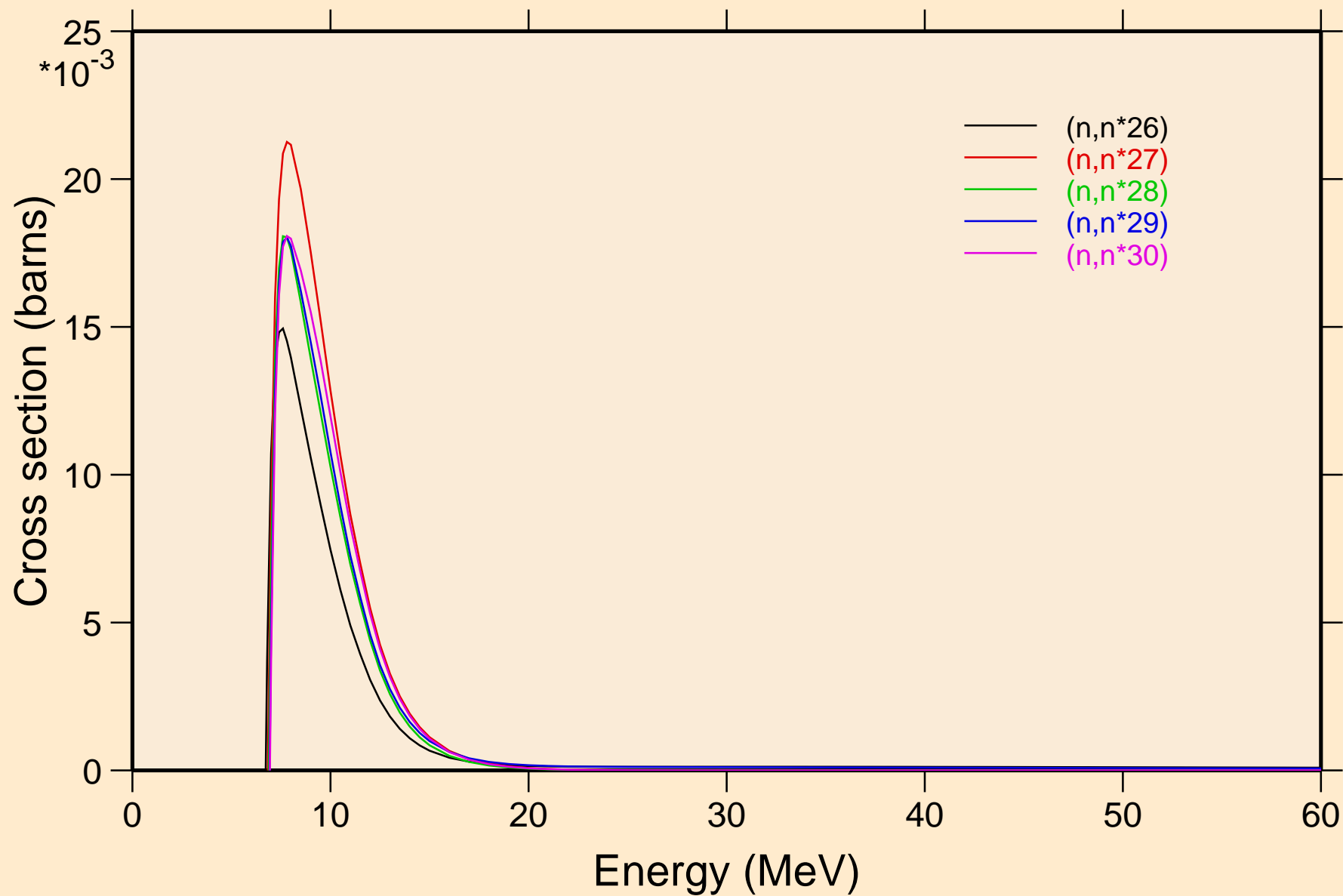

16-S-34 FOR FENDL-3.1 FROM TENDL-2010 WITH NJOY2012.50+

Threshold reactions

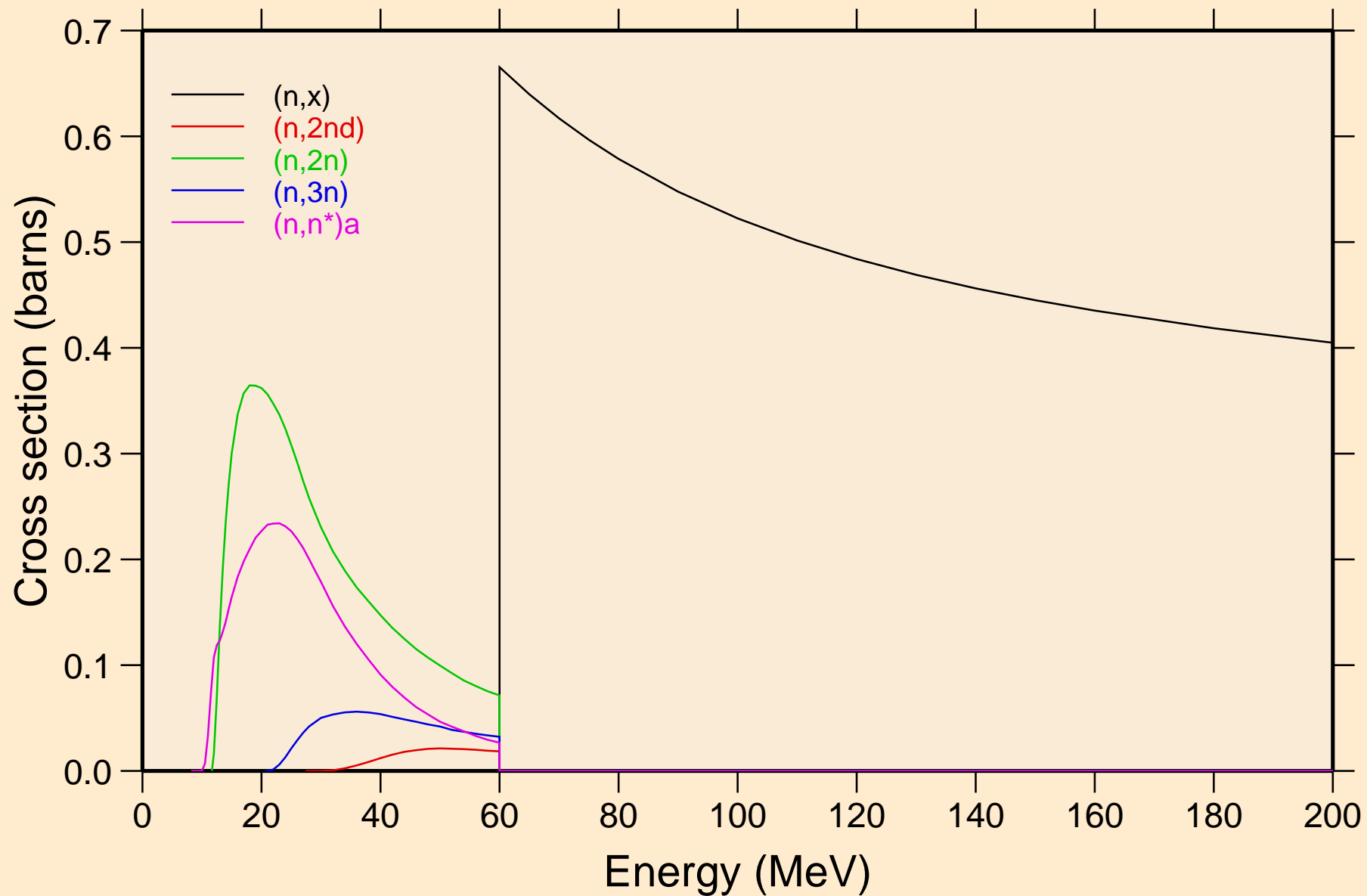

16-S-34 FOR FENDL-3.1 FROM TENDL-2010 WITH NJOY2012.50+

Threshold reactions

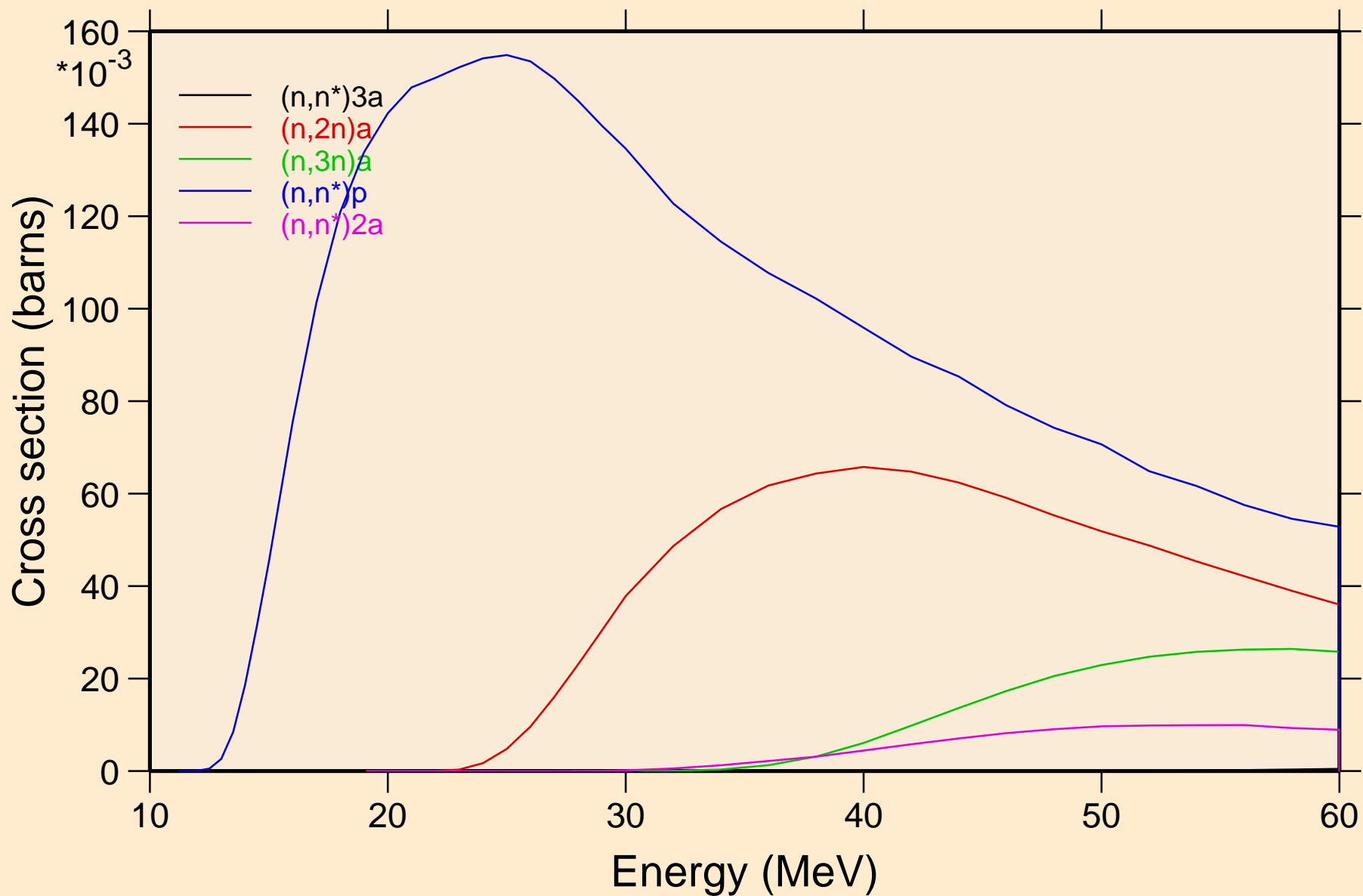

16-S-34 FOR FENDL-3.1 FROM TENDL-2010 WITH NJOY2012.50+

Threshold reactions

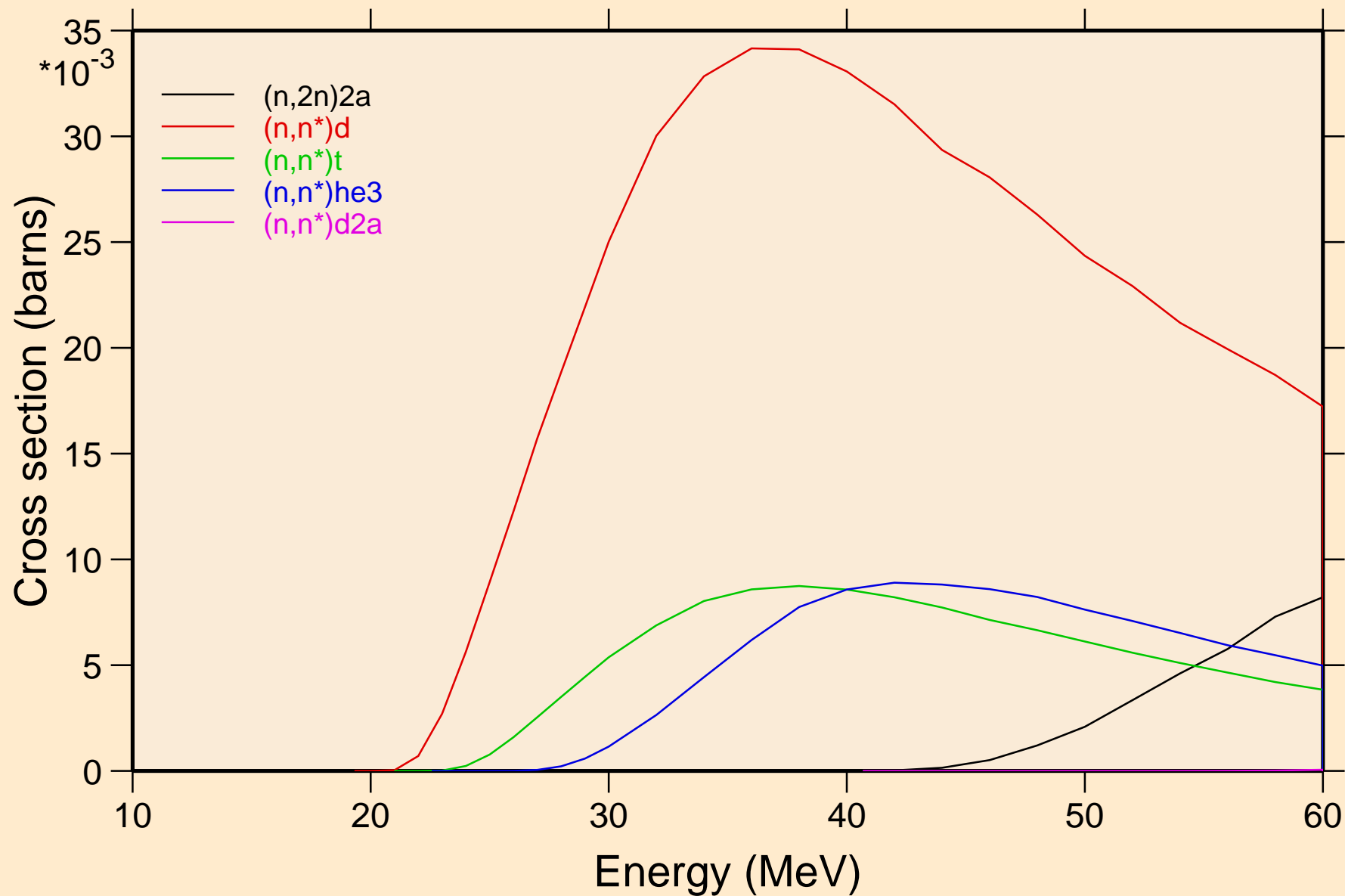

16-S-34 FOR FENDL-3.1 FROM TENDL-2010 WITH NJOY2012.50+

Threshold reactions

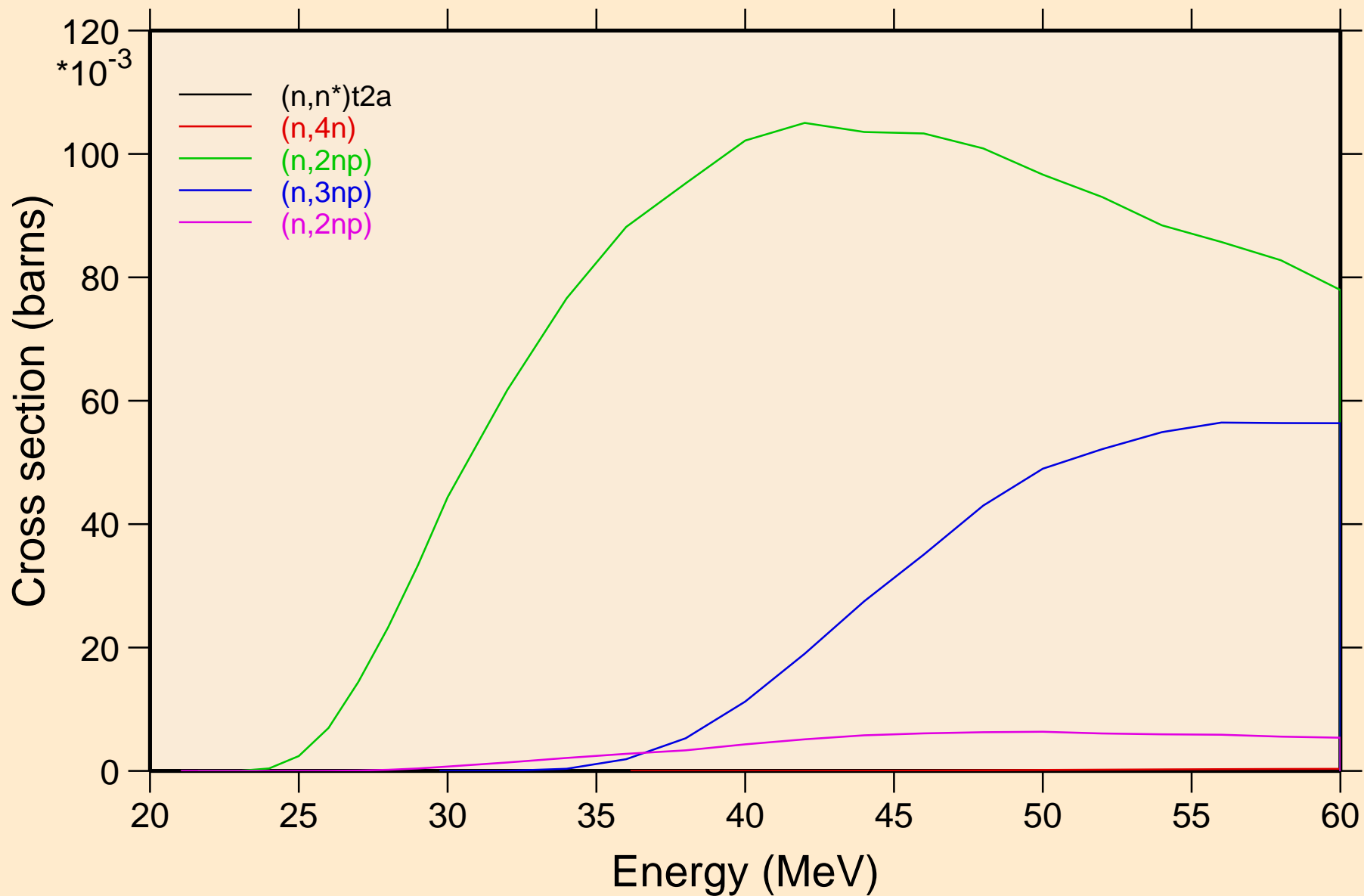

16-S-34 FOR FENDL-3.1 FROM TENDL-2010 WITH NJOY2012.50+

Threshold reactions

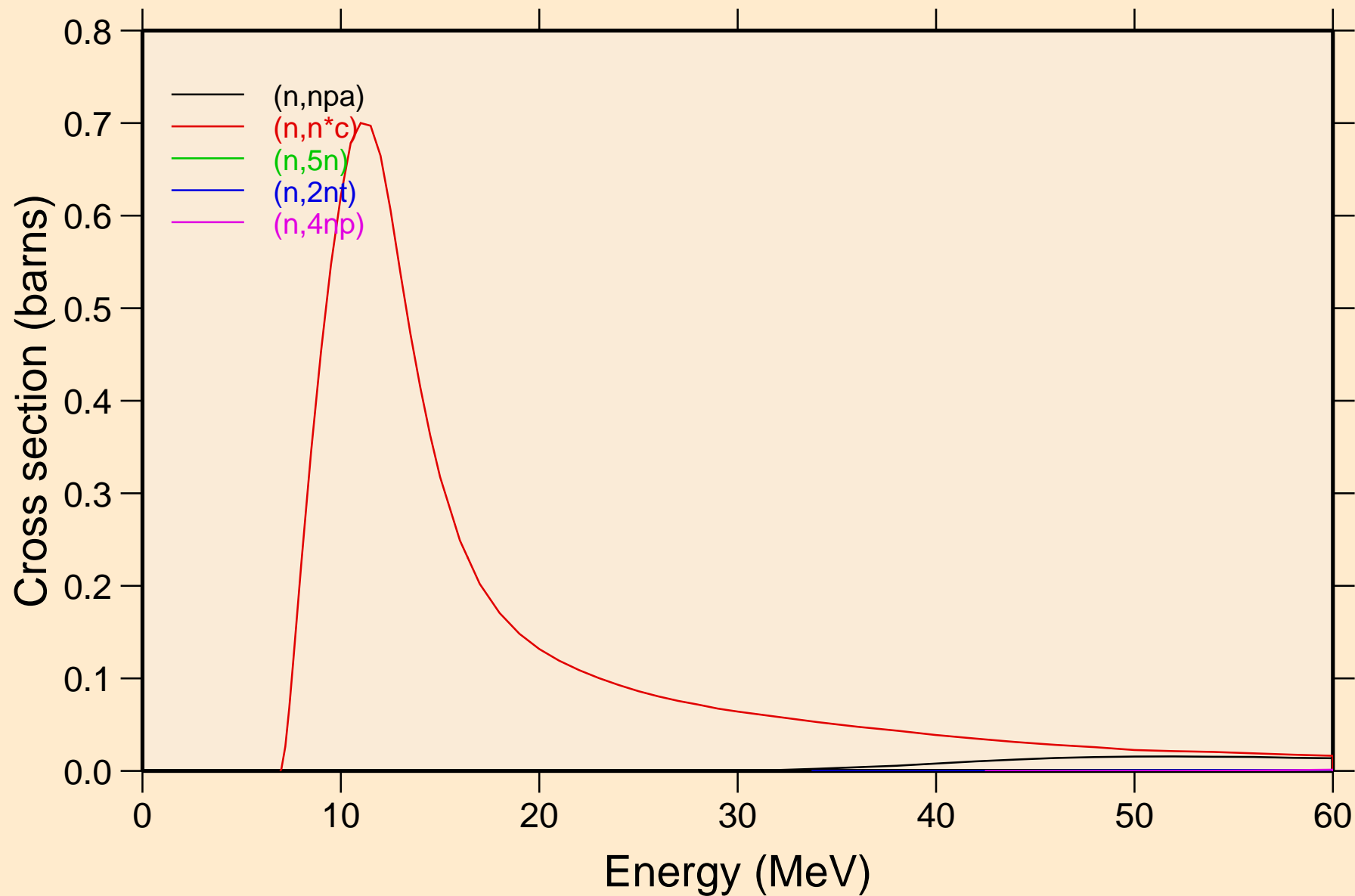

16-S-34 FOR FENDL-3.1 FROM TENDL-2010 WITH NJOY2012.50+

Threshold reactions

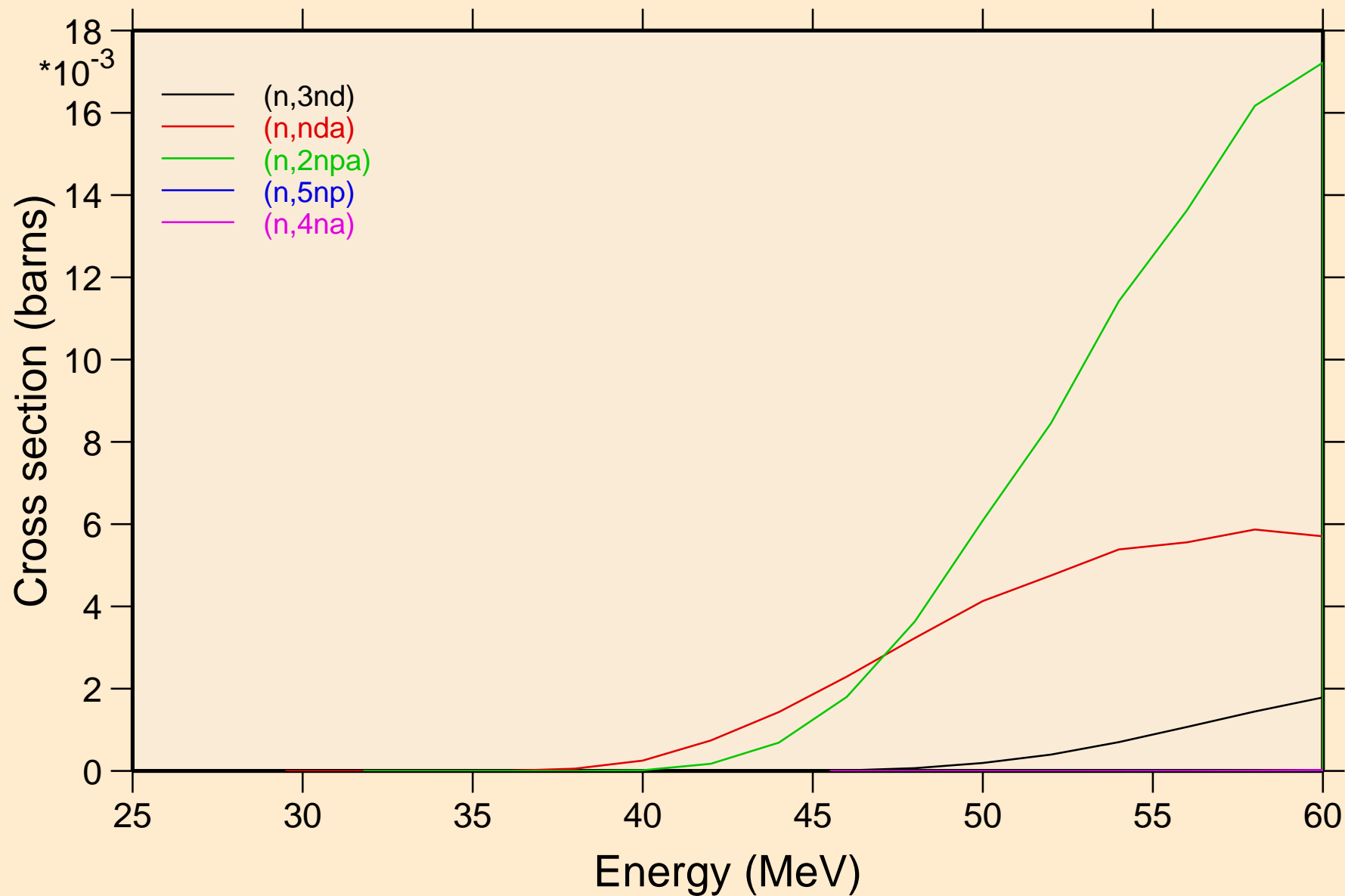

16-S-34 FOR FENDL-3.1 FROM TENDL-2010 WITH NJOY2012.50+

Threshold reactions

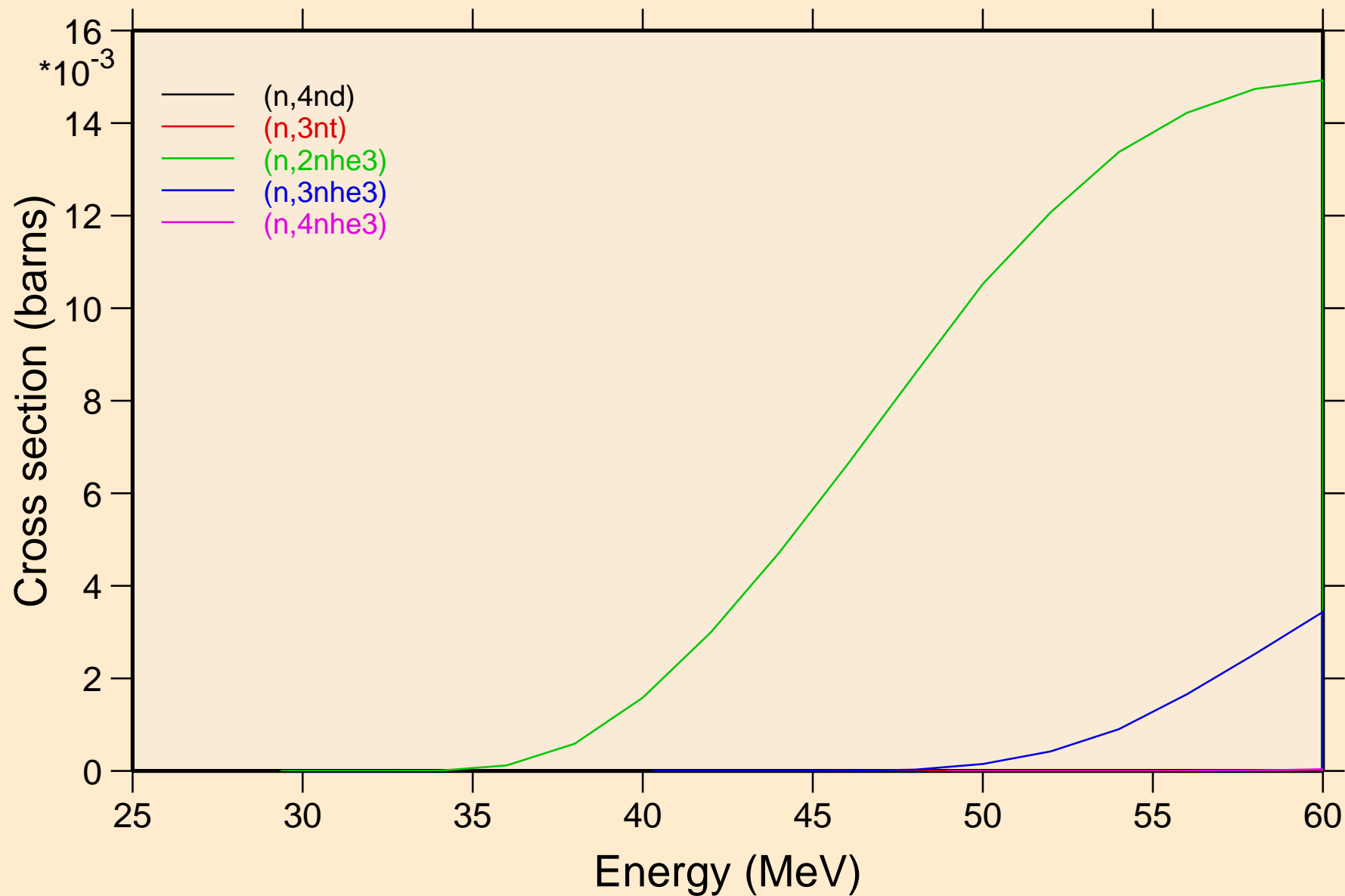

16-S-34 FOR FENDL-3.1 FROM TENDL-2010 WITH NJOY2012.50+ Threshold reactions

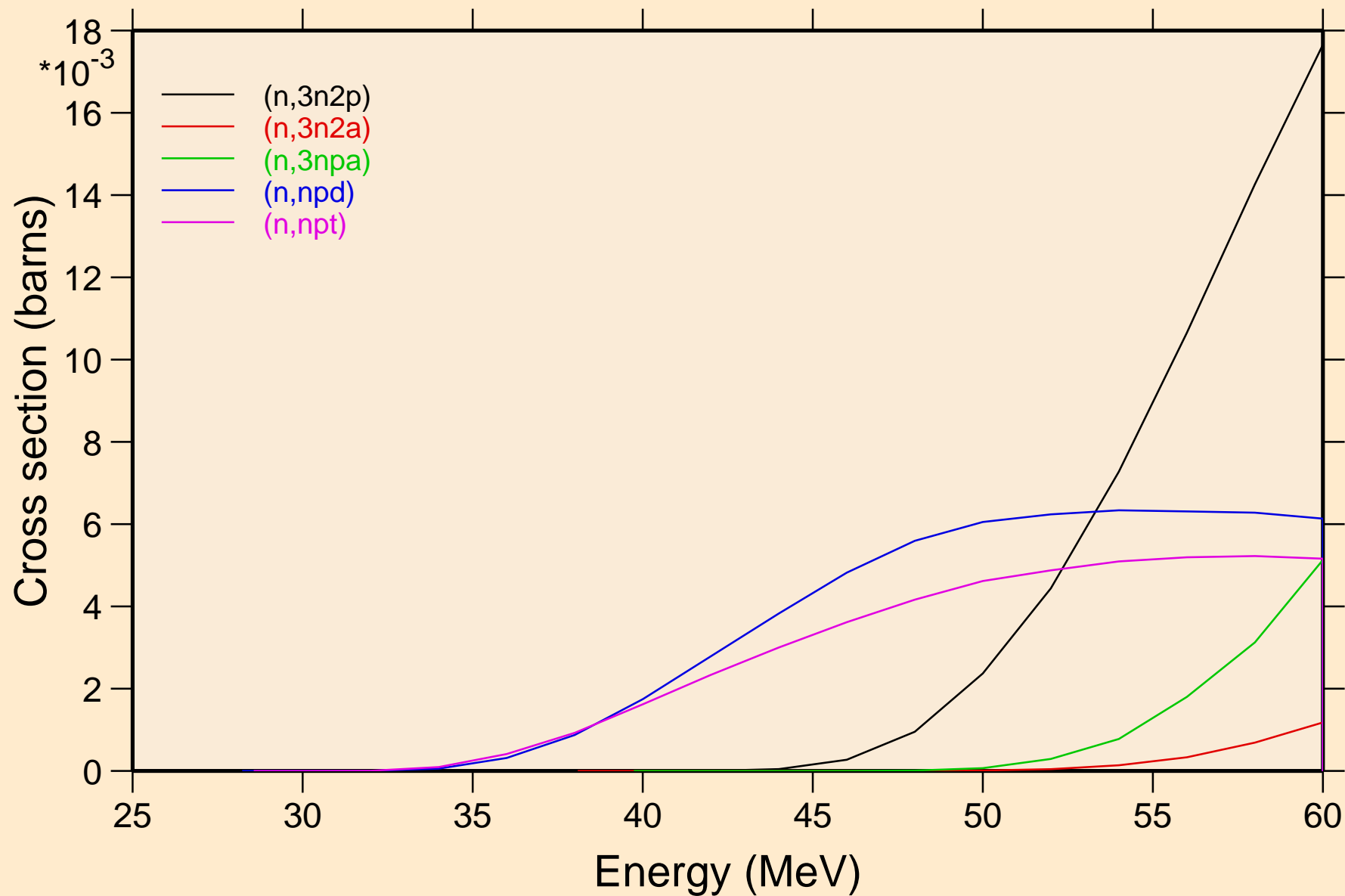

16-S-34 FOR FENDL-3.1 FROM TENDL-2010 WITH NJOY2012.50+ Threshold reactions

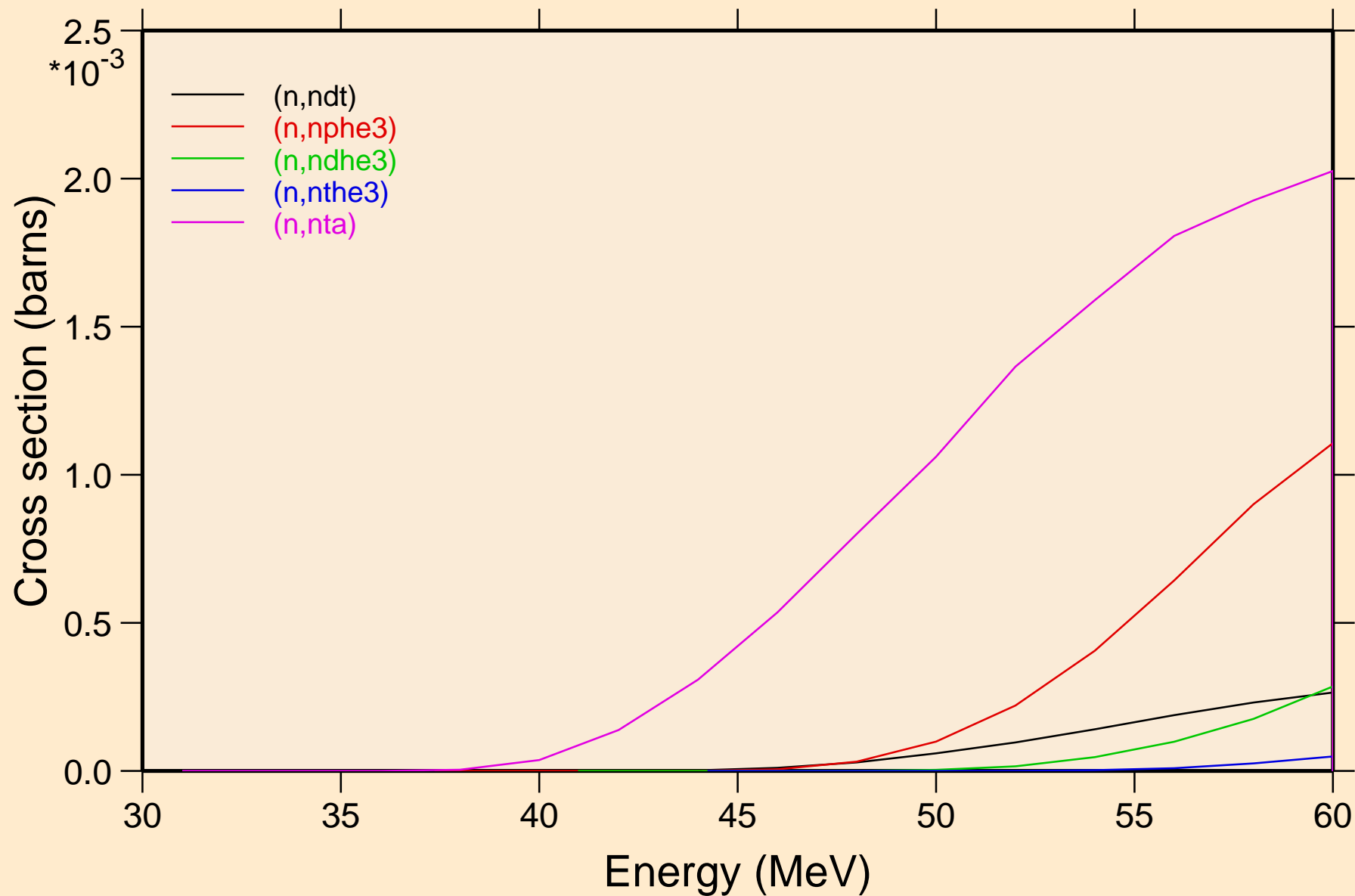

16-S-34 FOR FENDL-3.1 FROM TENDL-2010 WITH NJOY2012.50+

Threshold reactions

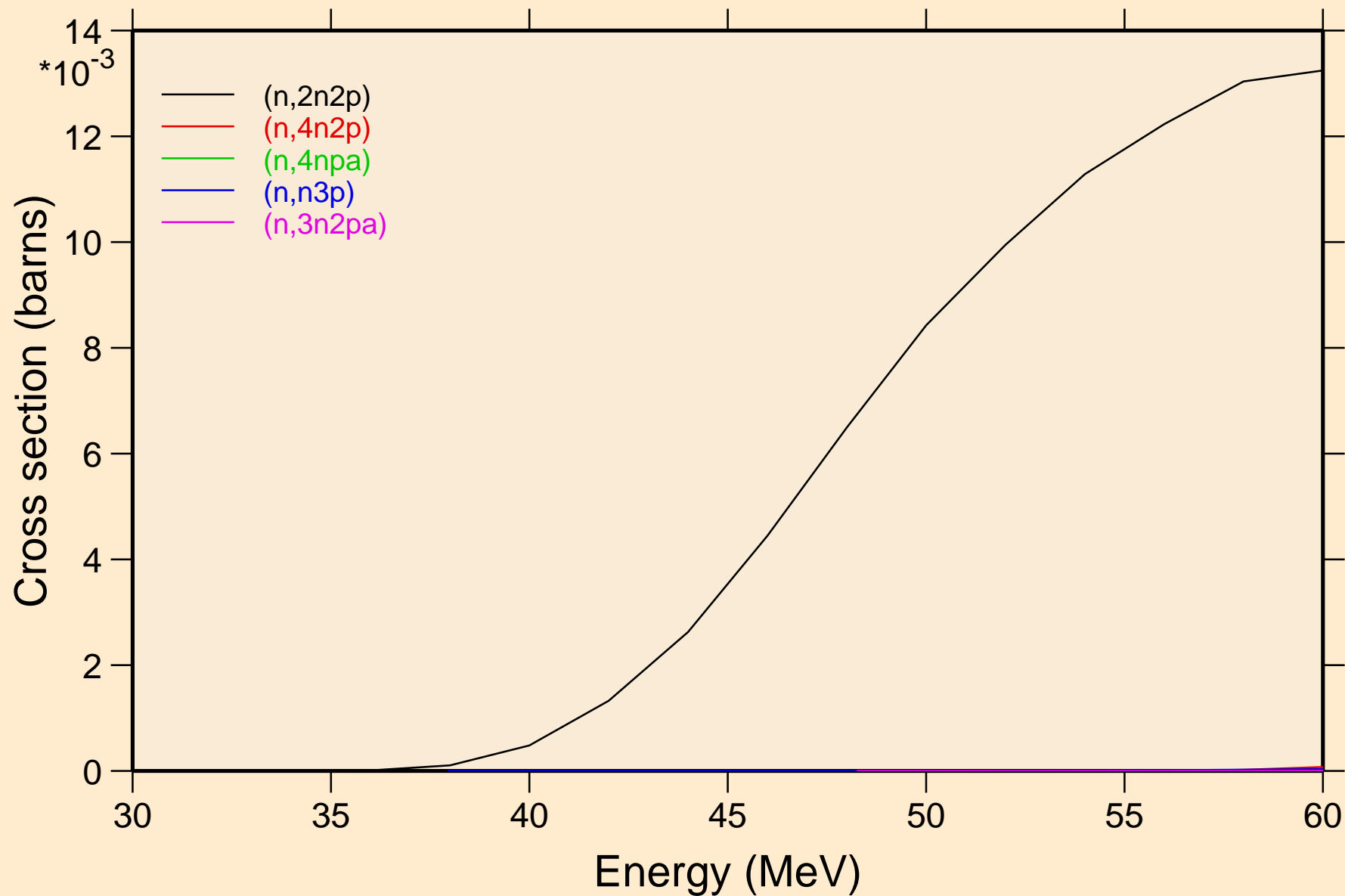

16-S-34 FOR FENDL-3.1 FROM TENDL-2010 WITH NJOY2012.50+ Threshold reactions

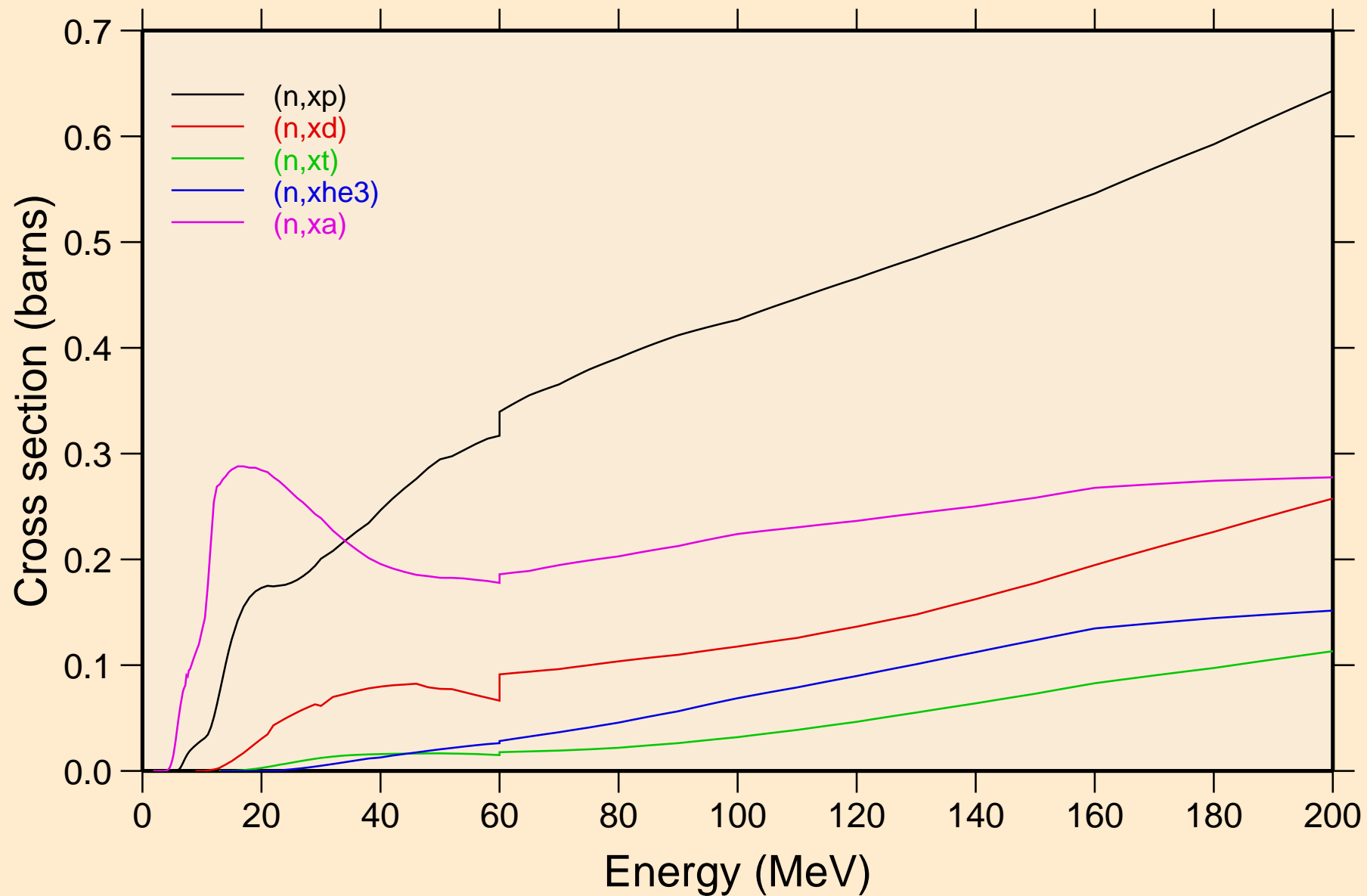

16-S-34 FOR FENDL-3.1 FROM TENDL-2010 WITH NJOY2012.50+
angular distribution for elastic

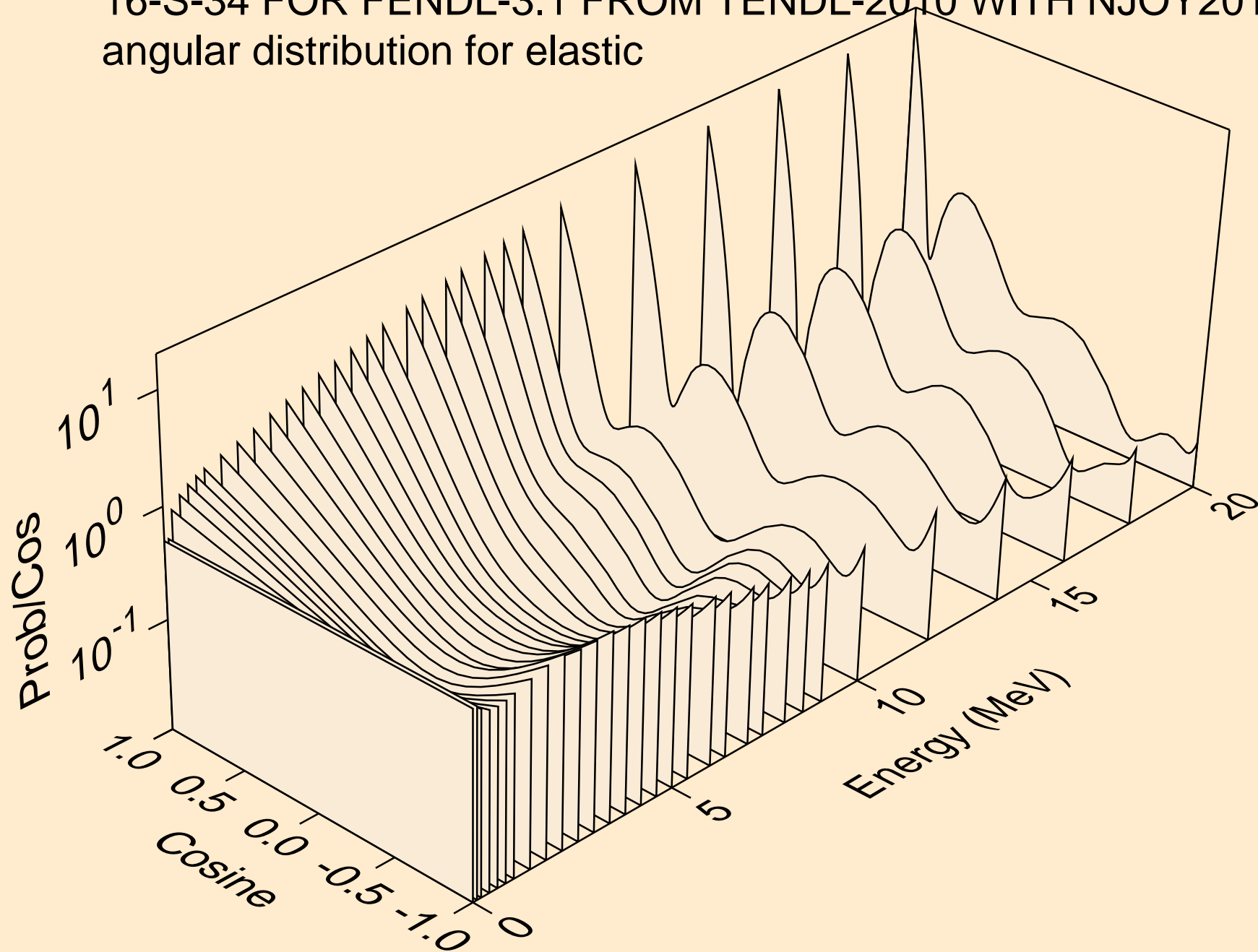

16-S-34 FOR FENDL-3.1 FROM TENDL-2010 WITH NJOY2012.50+
angular distribution for elastic

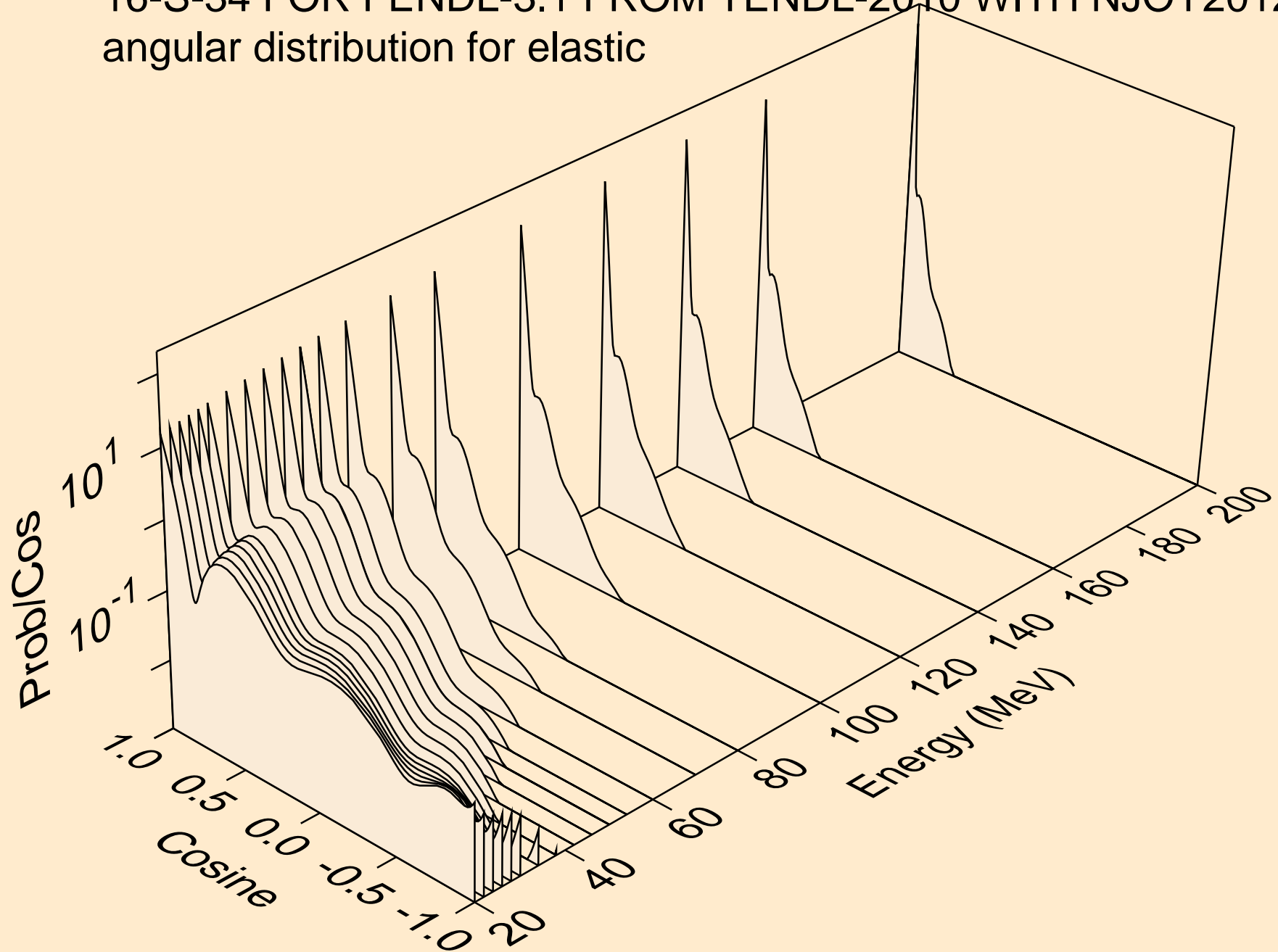

16-S-34 FOR FENDL-3.1 FROM TENDL-2010 WITH NJOY2012.50+
angular distribution for (n,n*1)

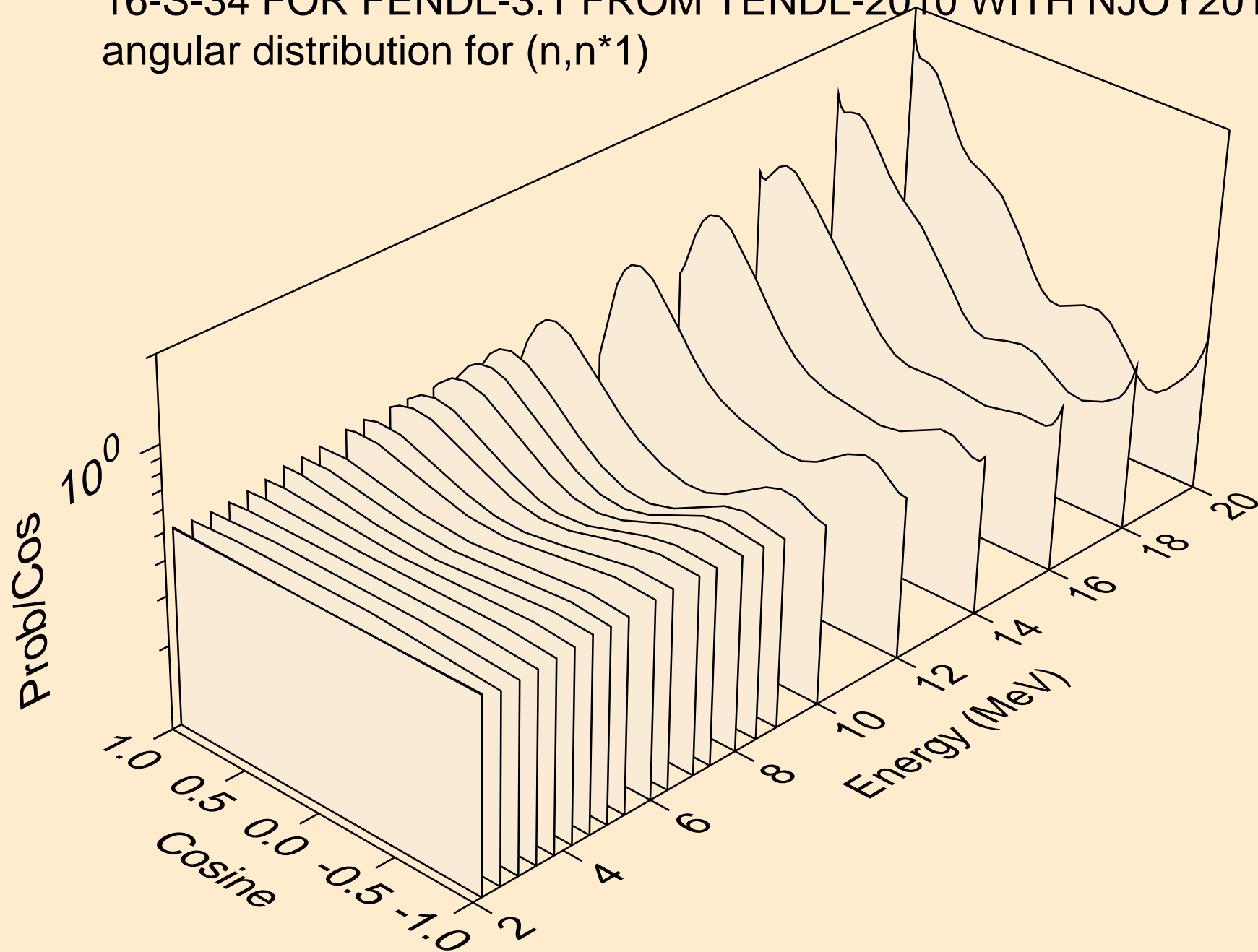

16-S-34 FOR FENDL-3.1 FROM TENDL-2010 WITH NJOY2012.50+
angular distribution for (n,n*1)

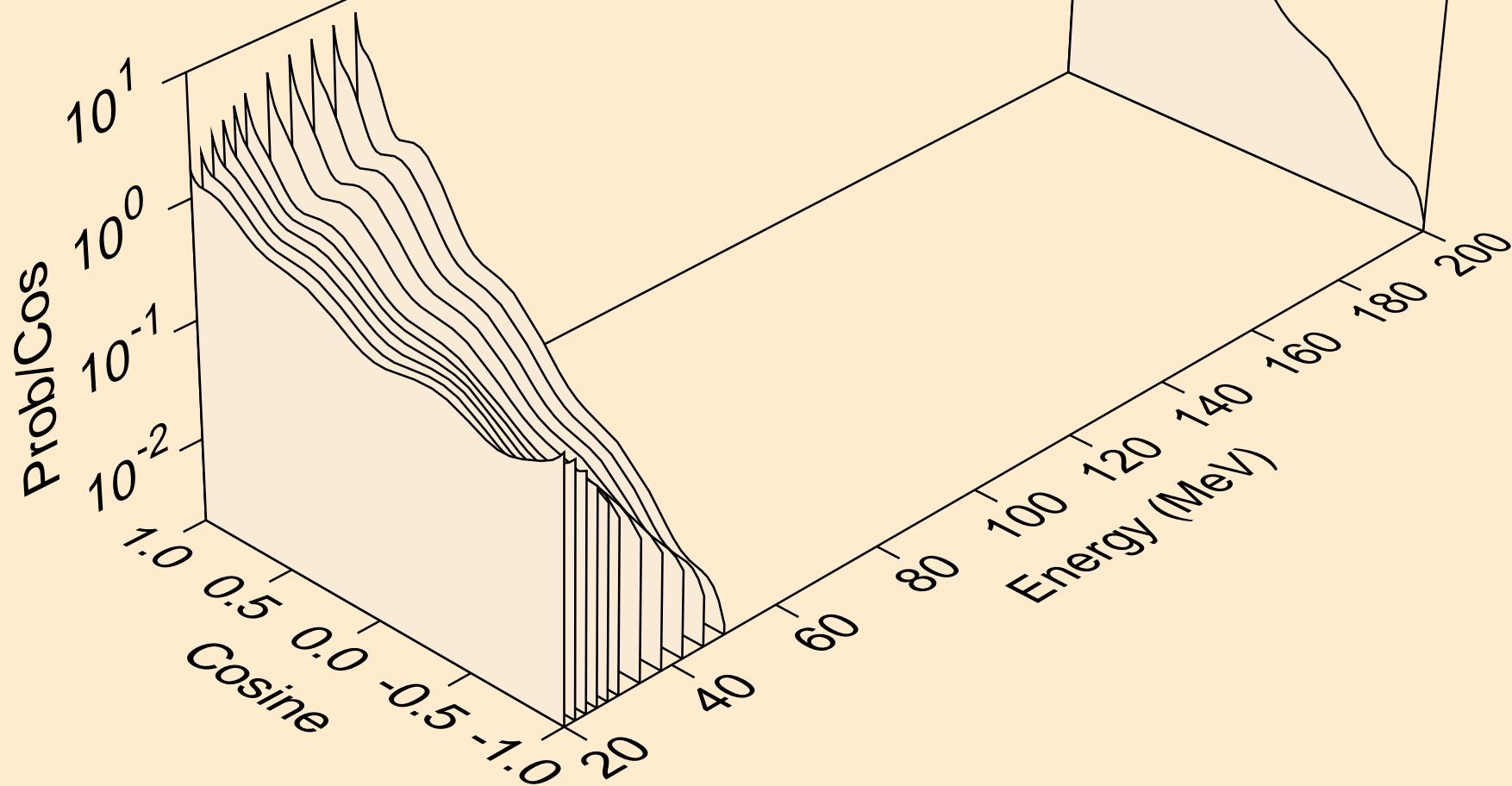

16-S-34 FOR FENDL-3.1 FROM TENDL-2010 WITH NJOY2012.50+
angular distribution for (n,n*2)

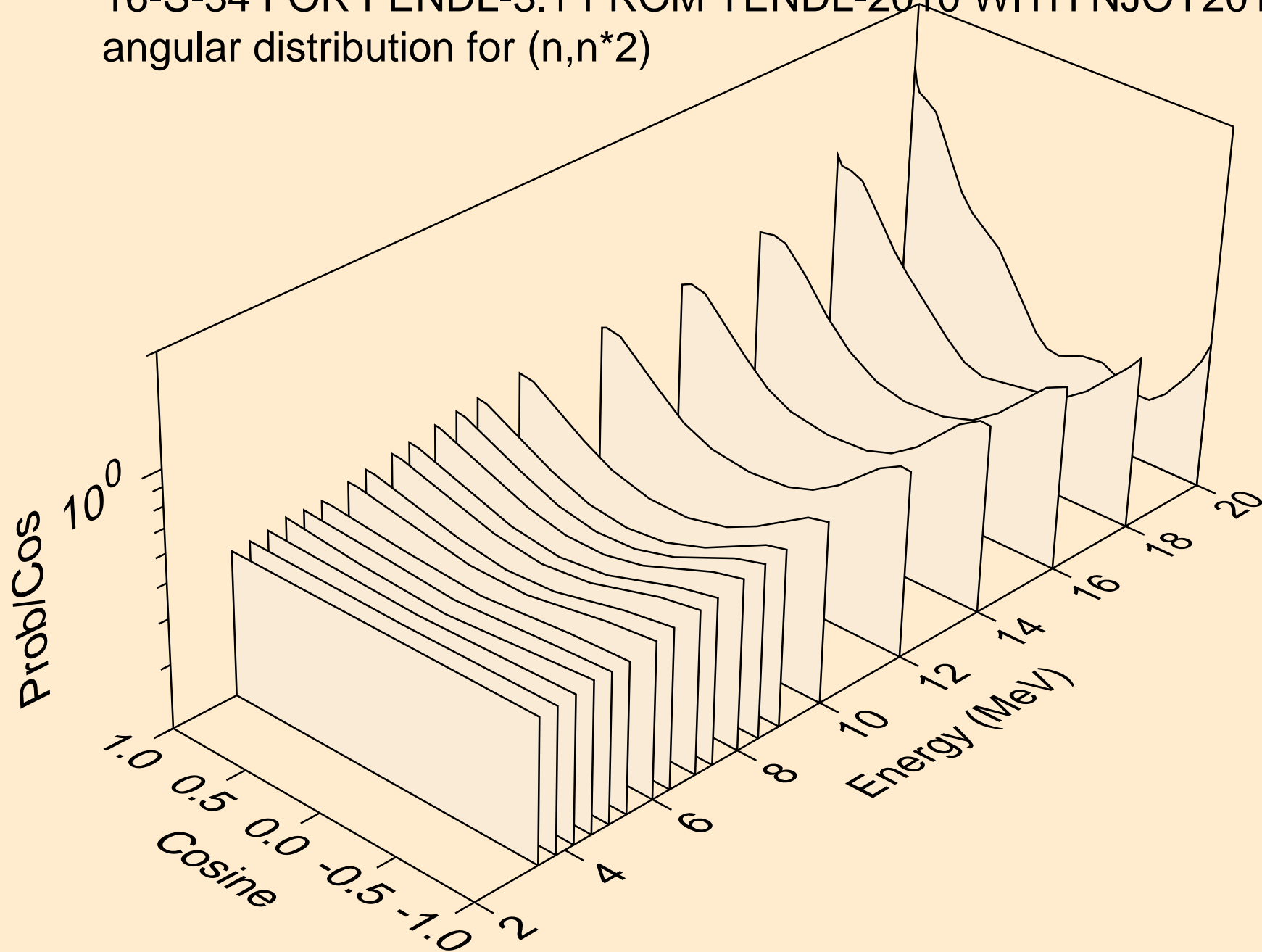

16-S-34 FOR FENDL-3.1 FROM TENDL-2010 WITH NJOY2012.50+
angular distribution for (n,n*2)

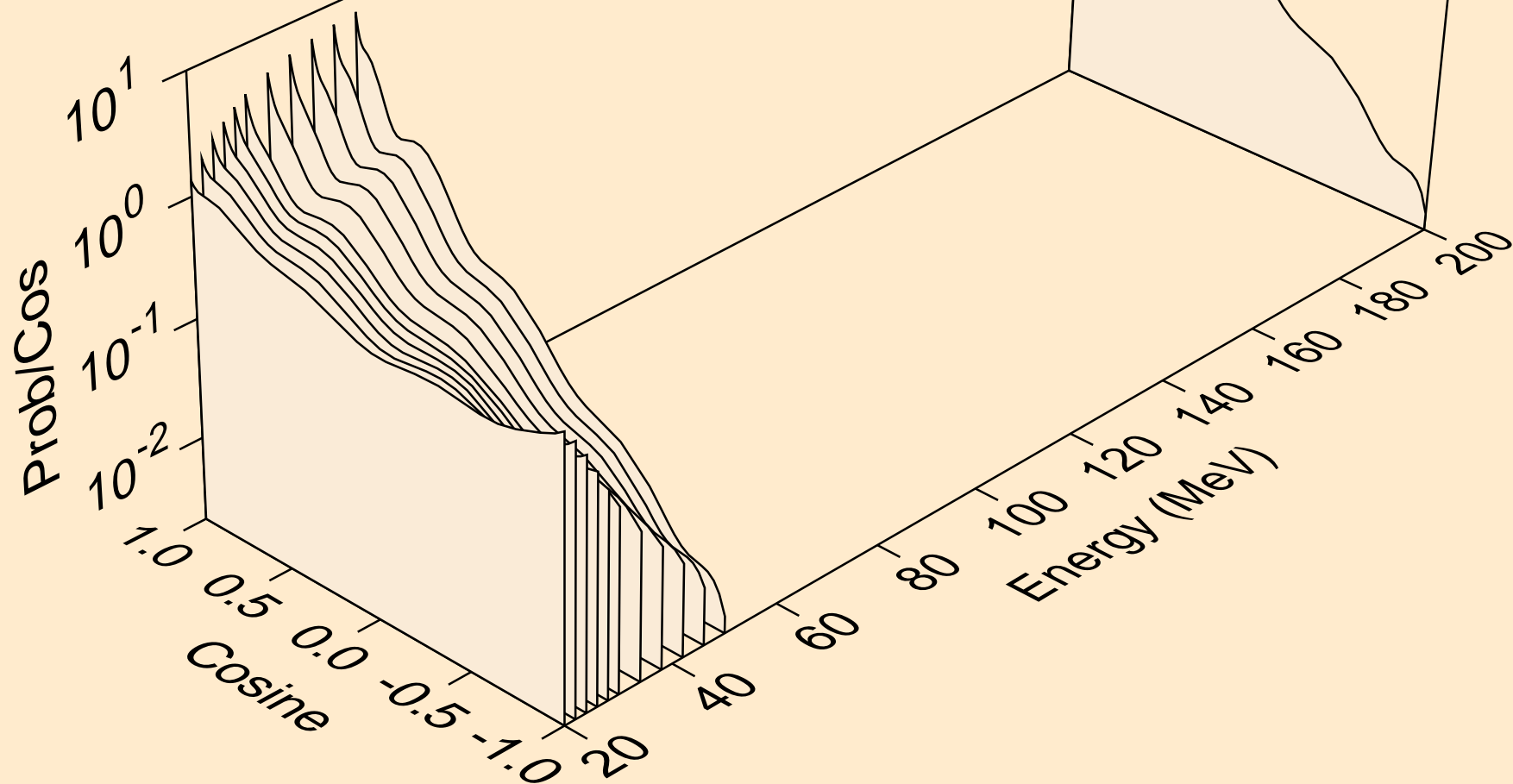

16-S-34 FOR FENDL-3.1 FROM TENDL-2010 WITH NJOY2012.50+
angular distribution for (n,n*3)

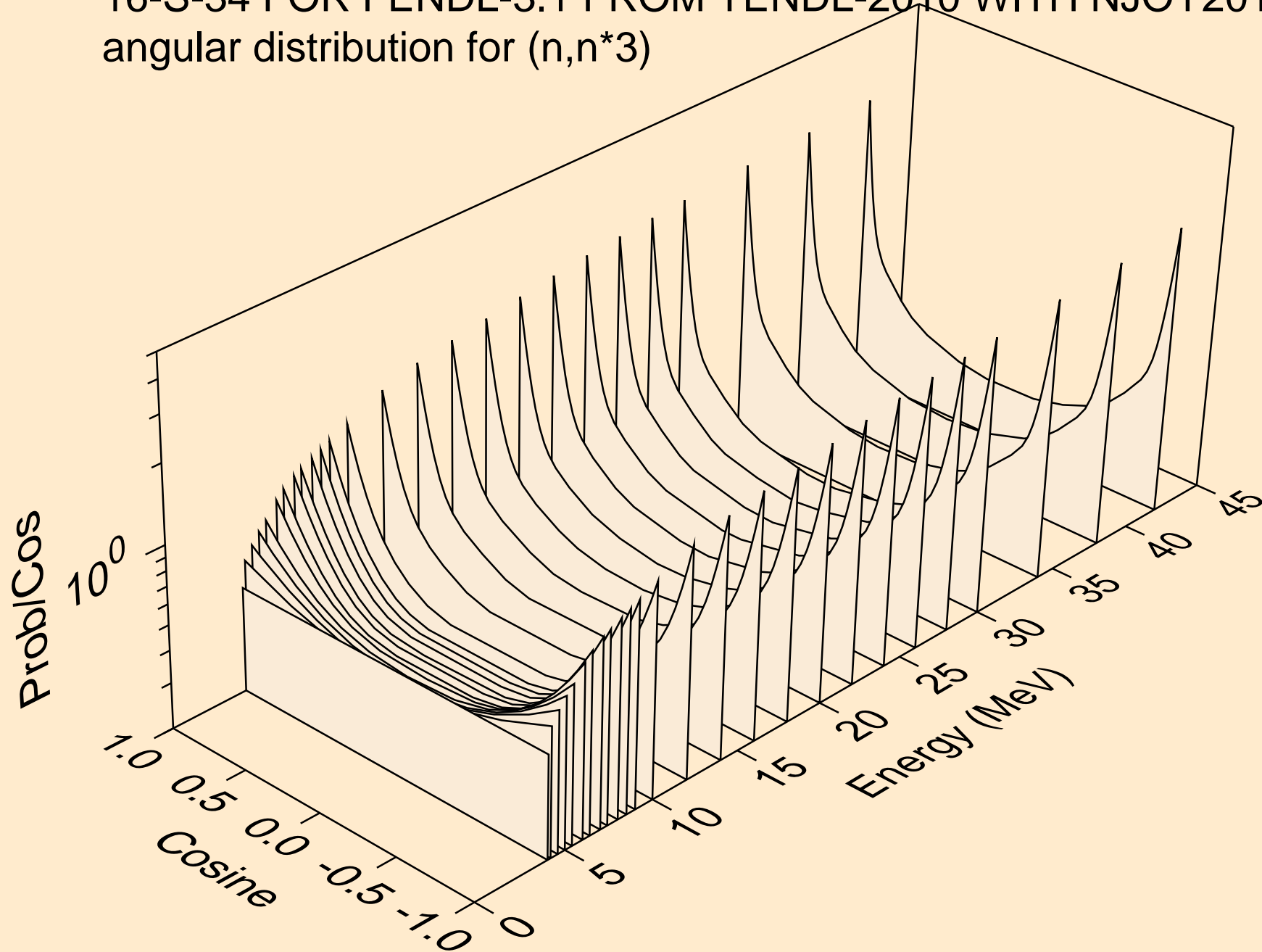

16-S-34 FOR FENDL-3.1 FROM TENDL-2010 WITH NJOY2012.50+
angular distribution for (n,n*4)

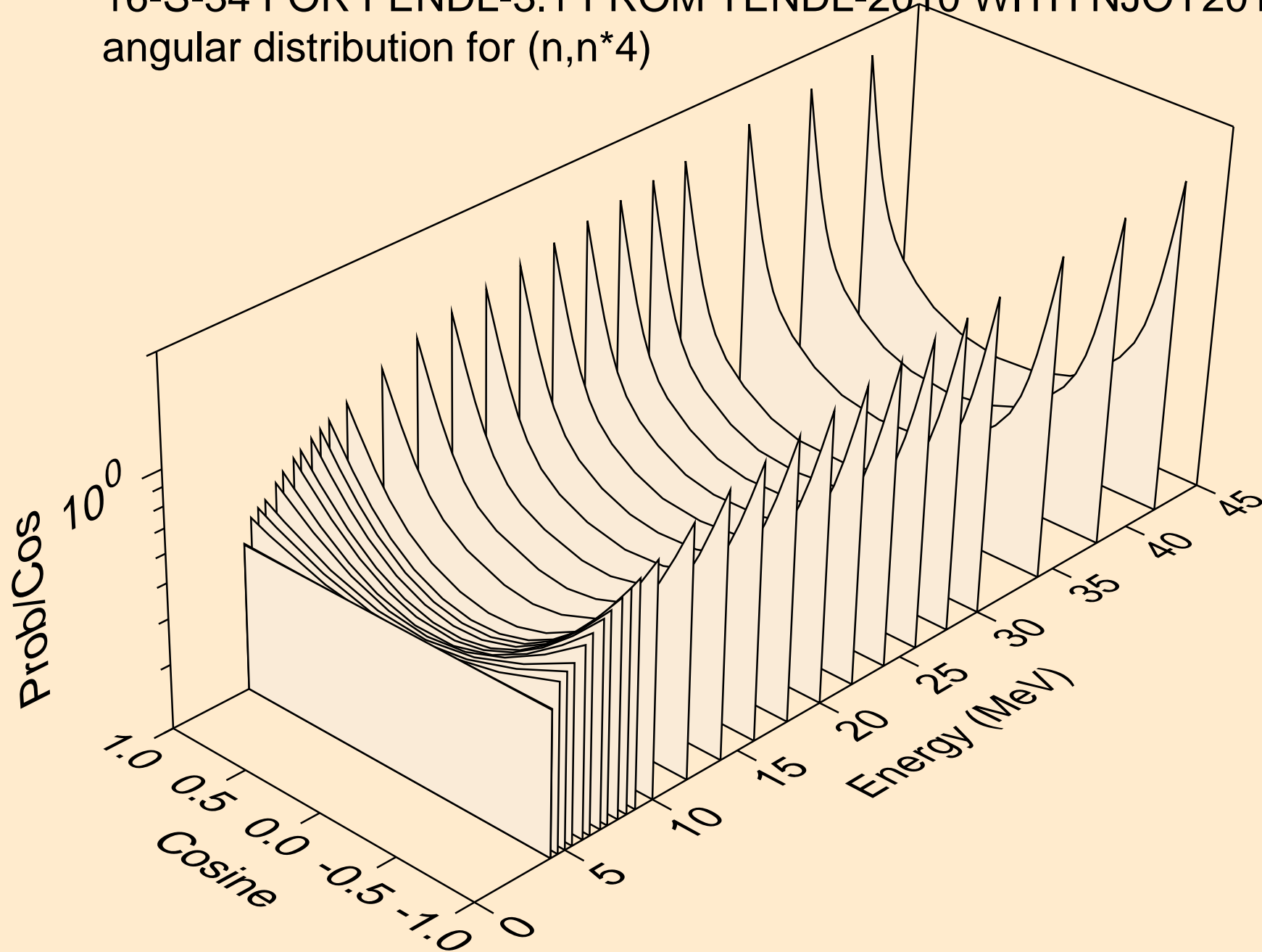

16-S-34 FOR FENDL-3.1 FROM TENDL-2010 WITH NJOY2012.50+
angular distribution for (n,n*5)

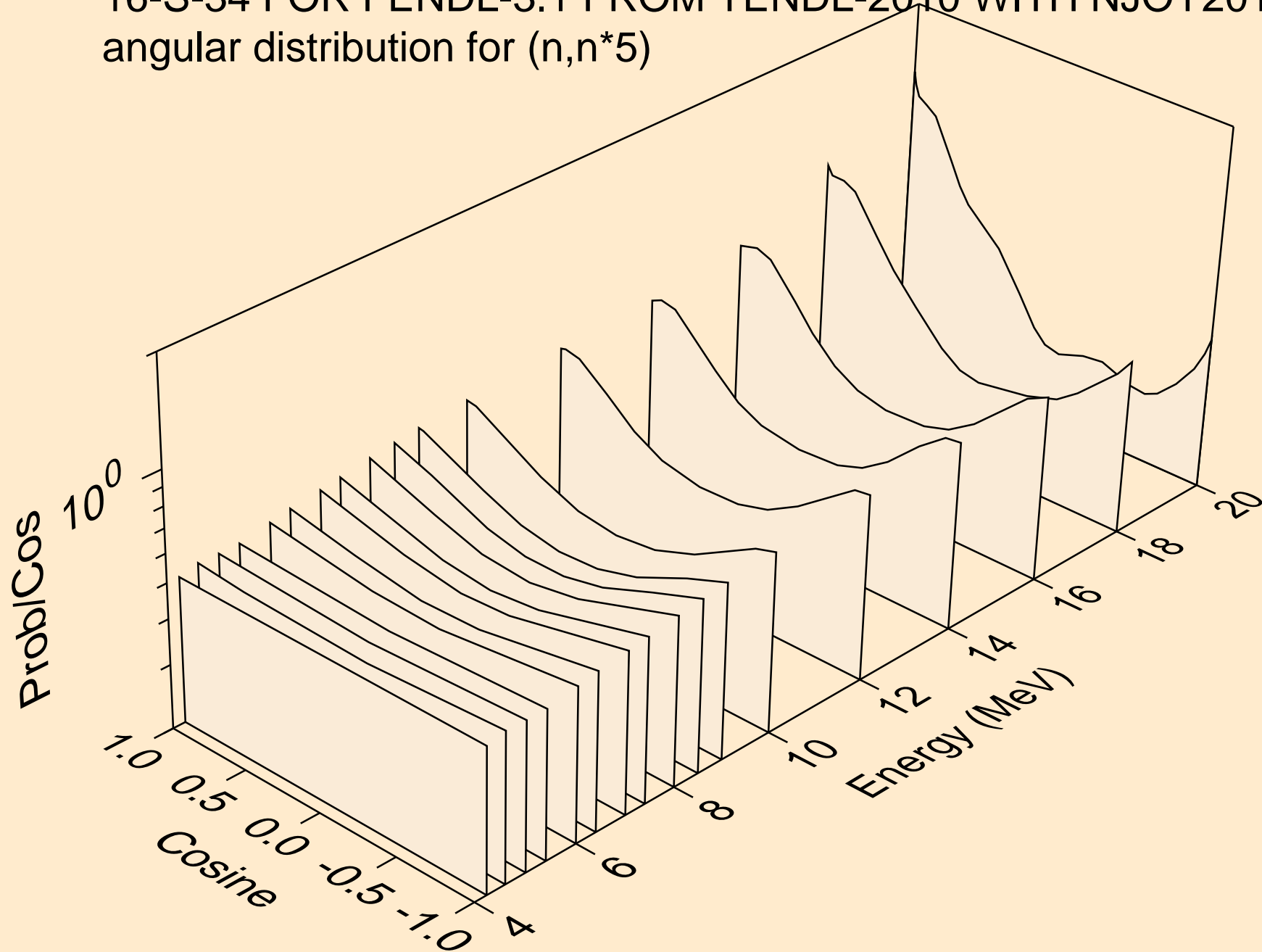

16-S-34 FOR FENDL-3.1 FROM TENDL-2010 WITH NJOY2012.50+
angular distribution for (n,n*5)

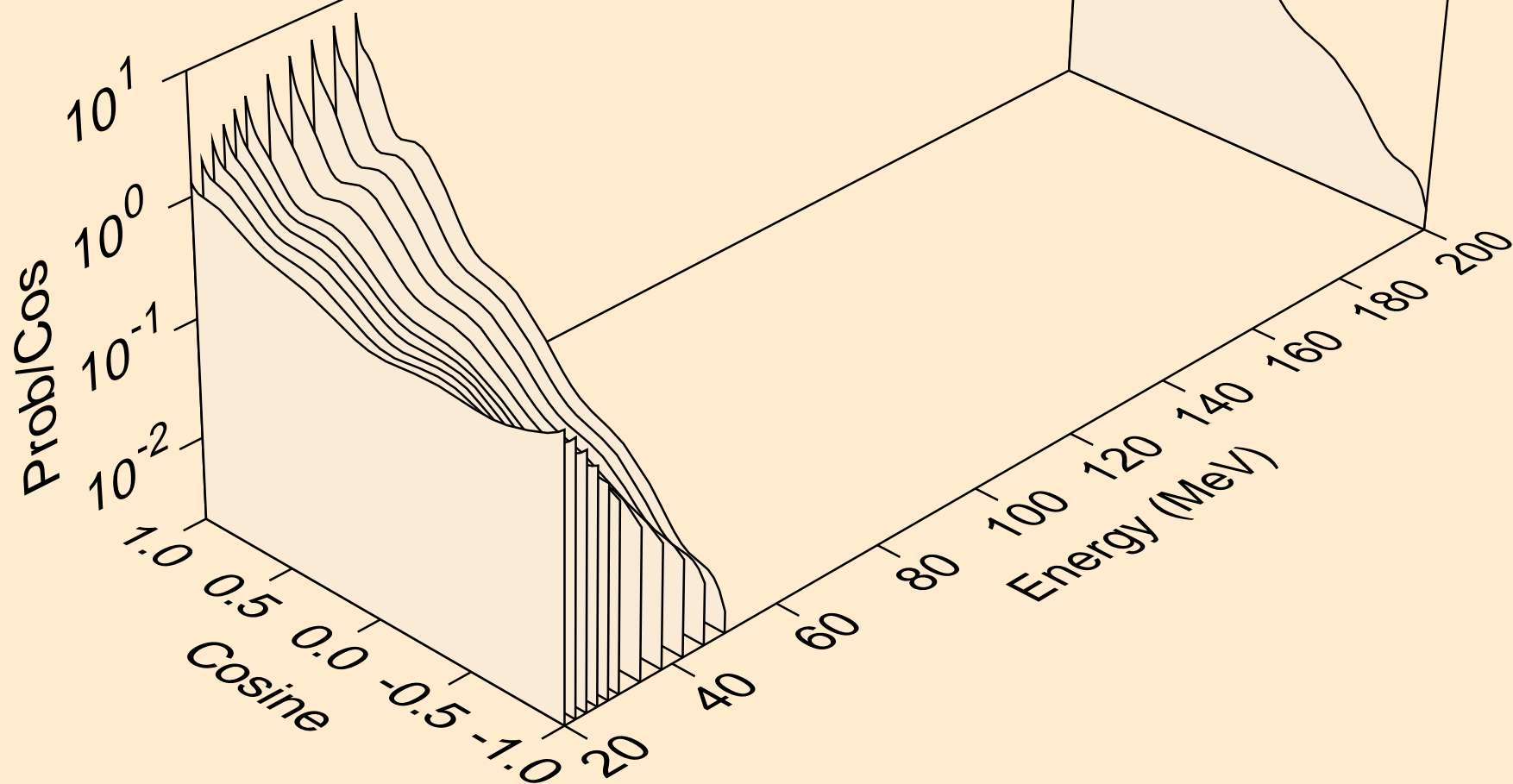

16-S-34 FOR FENDL-3.1 FROM TENDL-2010 WITH NJOY2012.50+
angular distribution for (n,n*6)

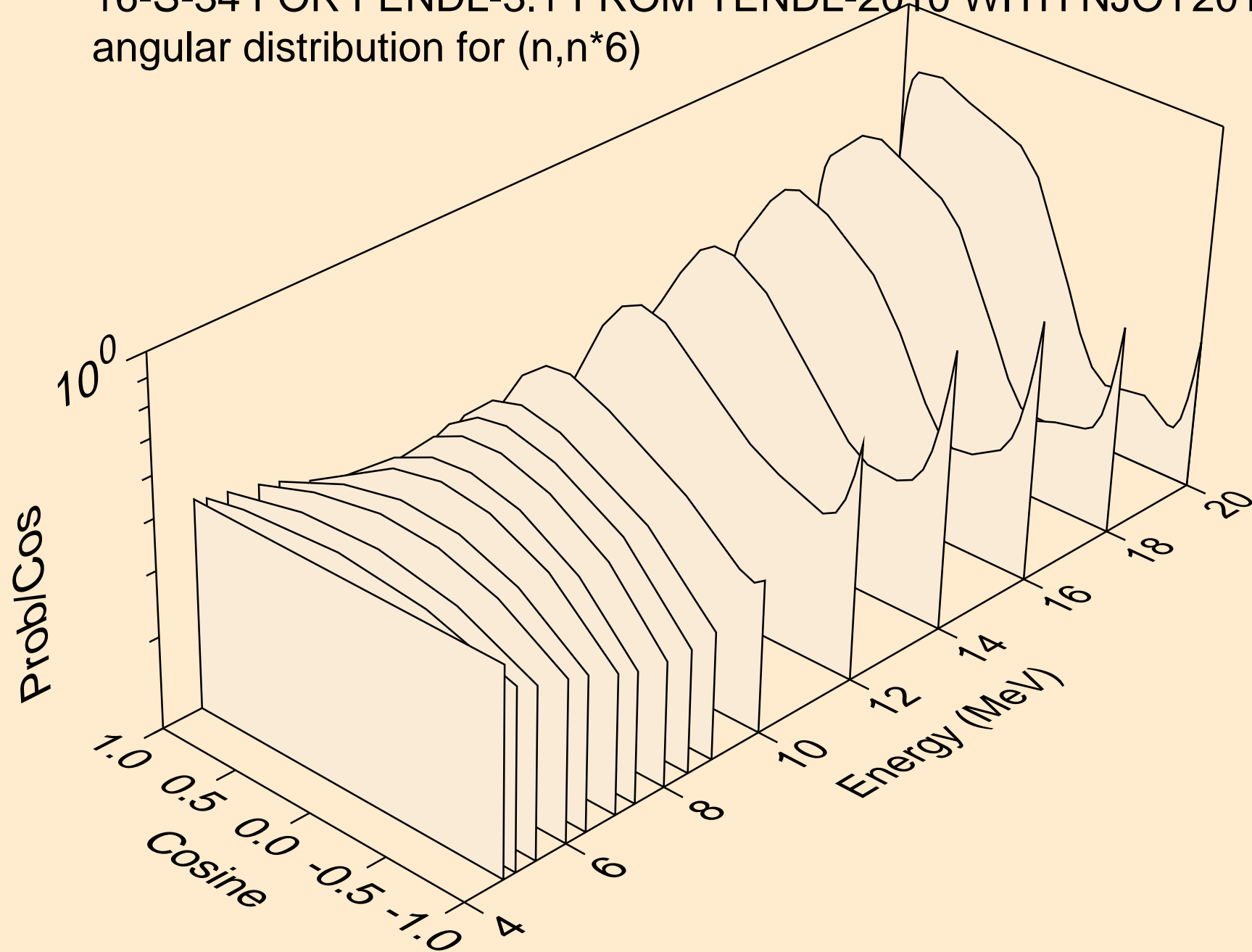

16-S-34 FOR FENDL-3.1 FROM TENDL-2010 WITH NJOY2012.50+
angular distribution for (n,n*6)

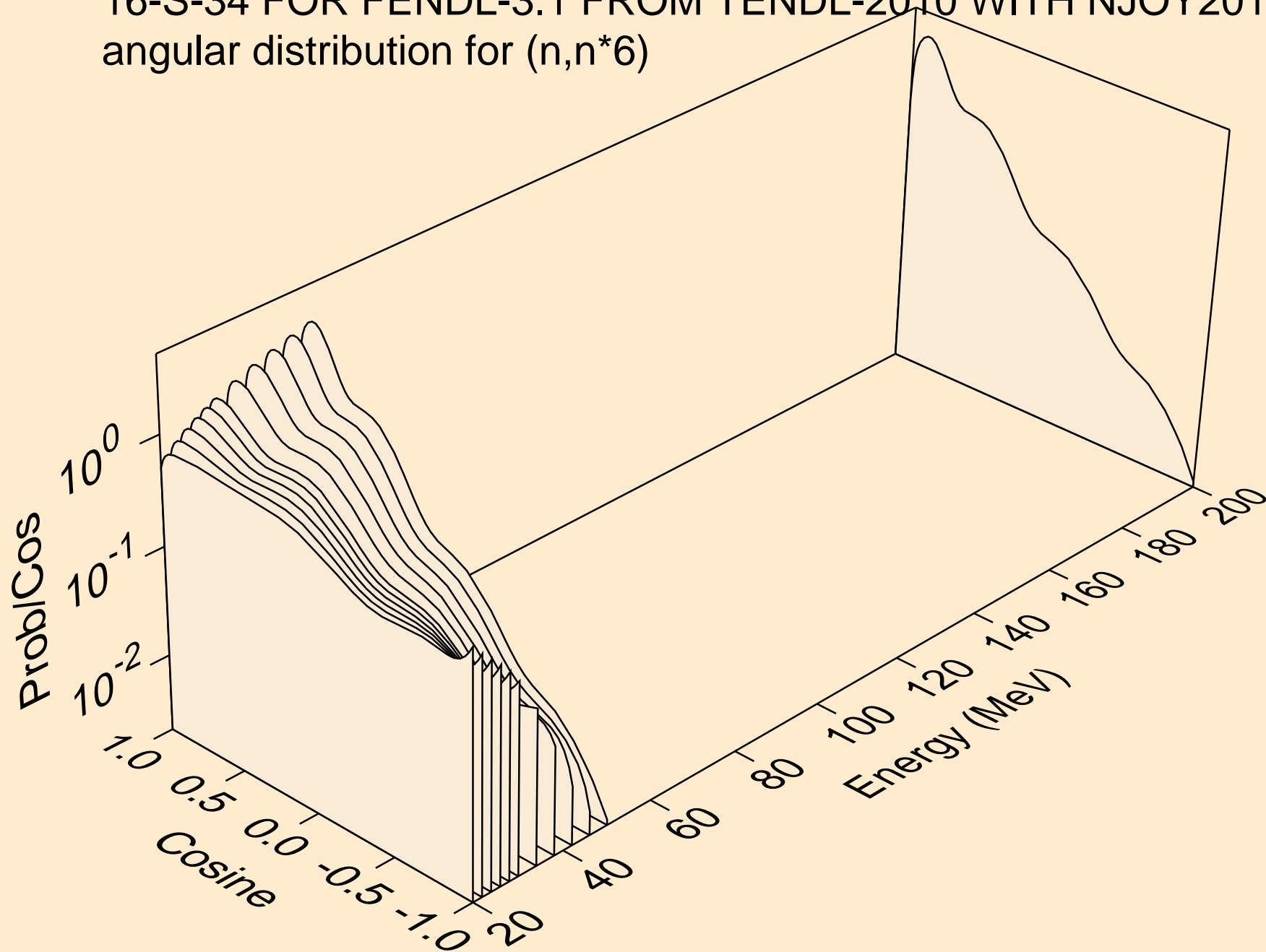

16-S-34 FOR FENDL-3.1 FROM TENDL-2010 WITH NJOY2012.50+
angular distribution for (n,n*7)

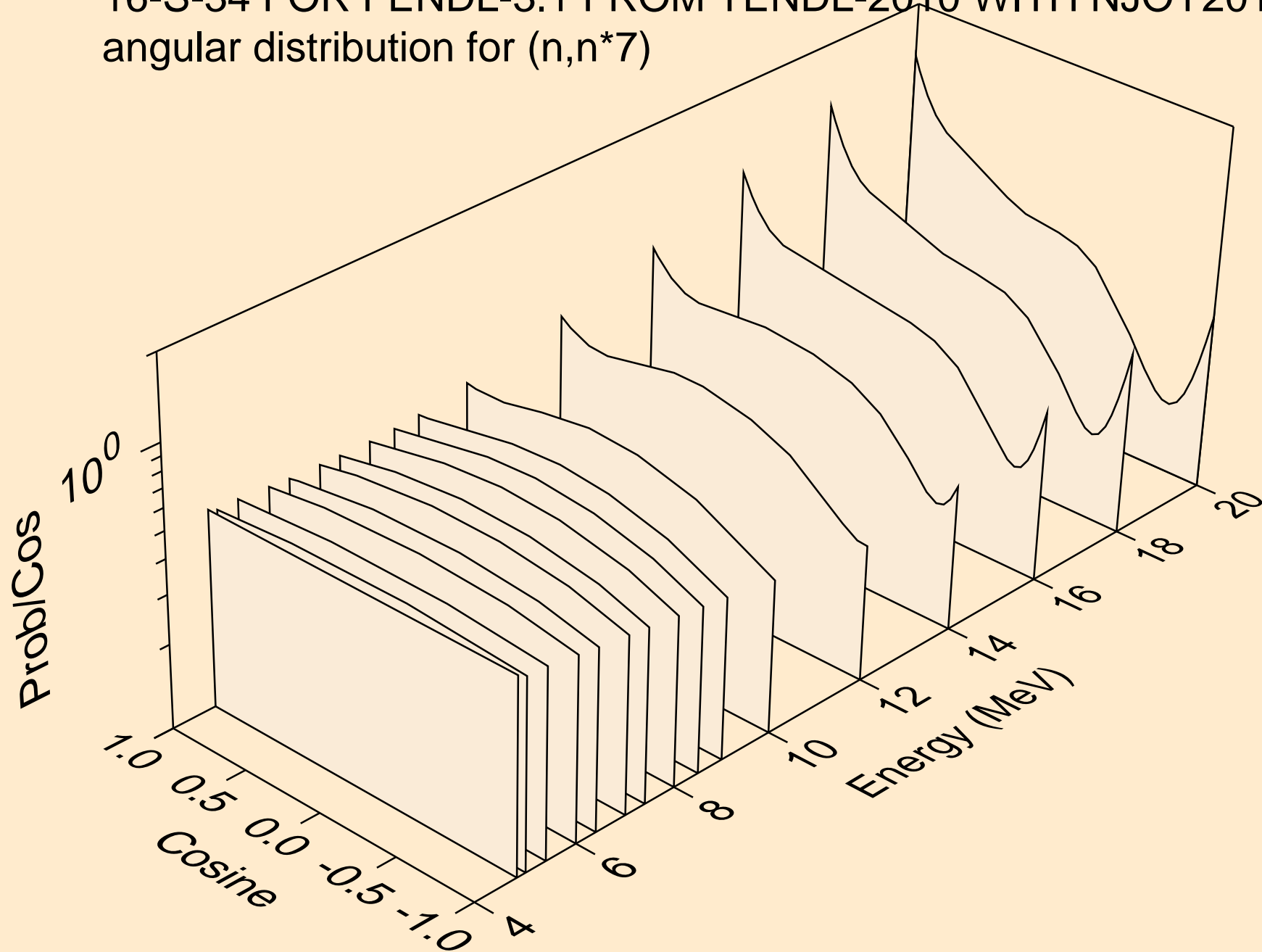

16-S-34 FOR FENDL-3.1 FROM TENDL-2010 WITH NJOY2012.50+
angular distribution for (n,n*7)

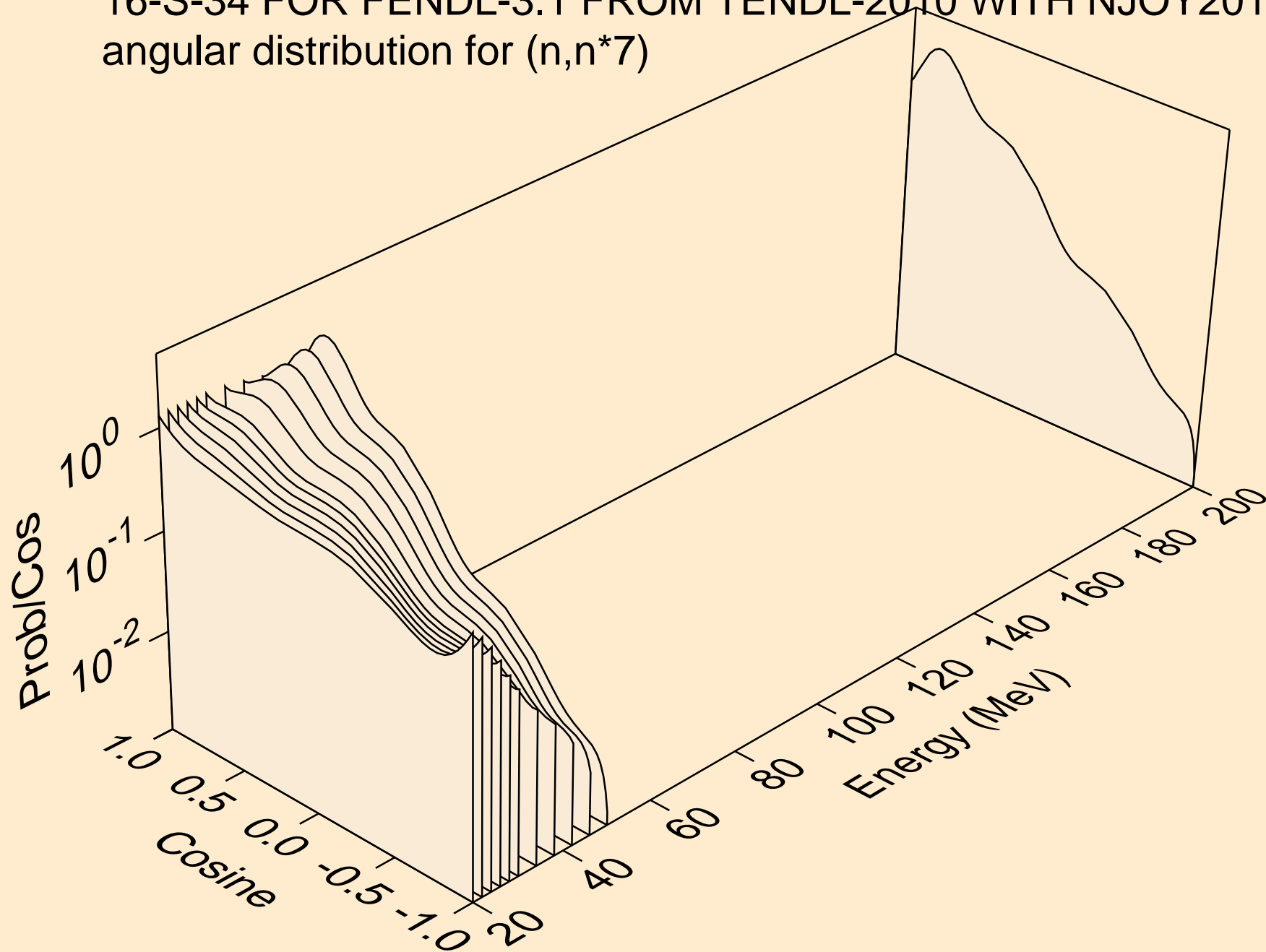

16-S-34 FOR FENDL-3.1 FROM TENDL-2010 WITH NJOY2012.50+
angular distribution for (n,n*8)

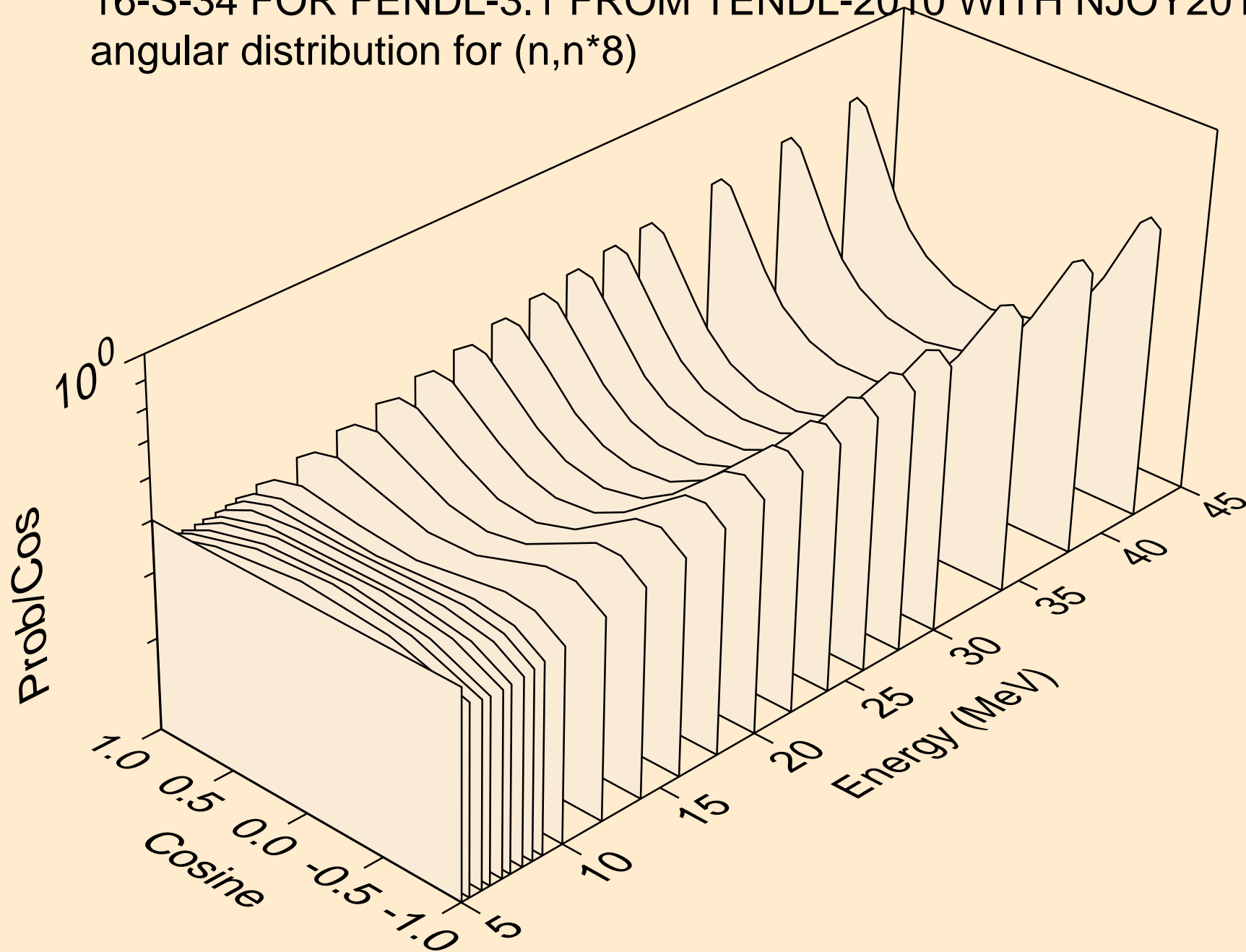

16-S-34 FOR FENDL-3.1 FROM TENDL-2010 WITH NJOY2012.50+
angular distribution for (n,n*9)

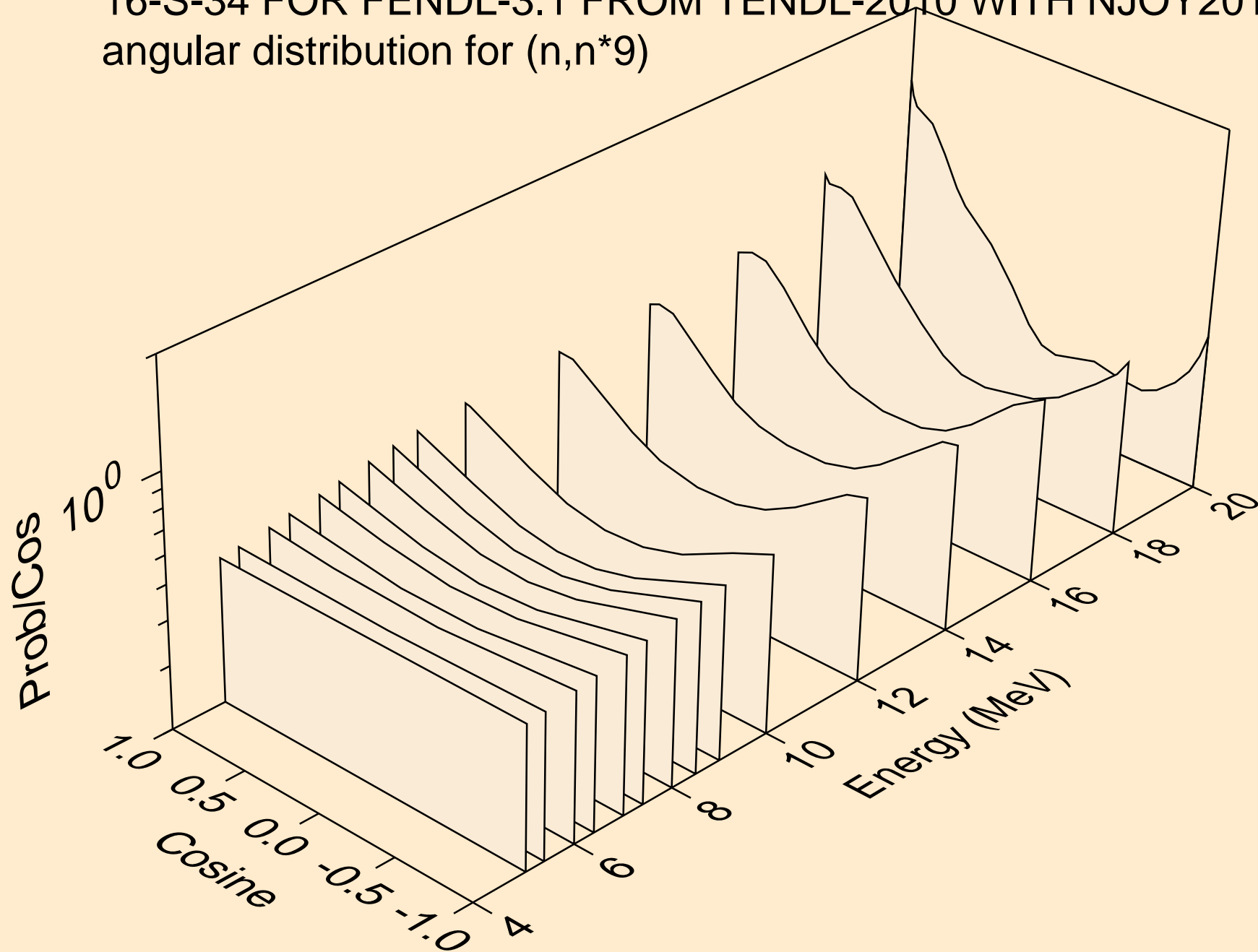

16-S-34 FOR FENDL-3.1 FROM TENDL-2010 WITH NJOY2012.50+
angular distribution for (n,n*9)

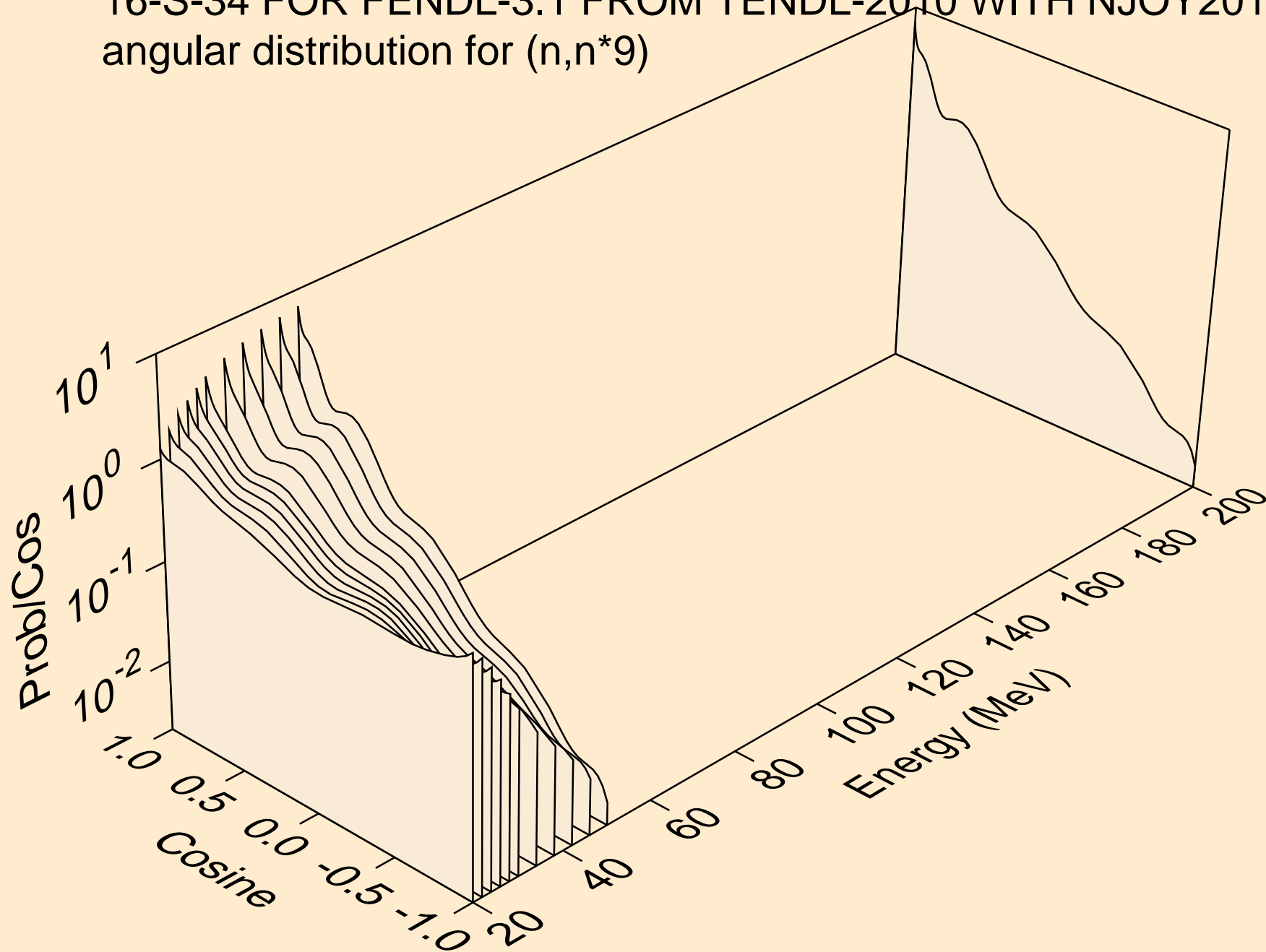

16-S-34 FOR FENDL-3.1 FROM TENDL-2010 WITH NJOY2012.50+
angular distribution for (n,n*10)

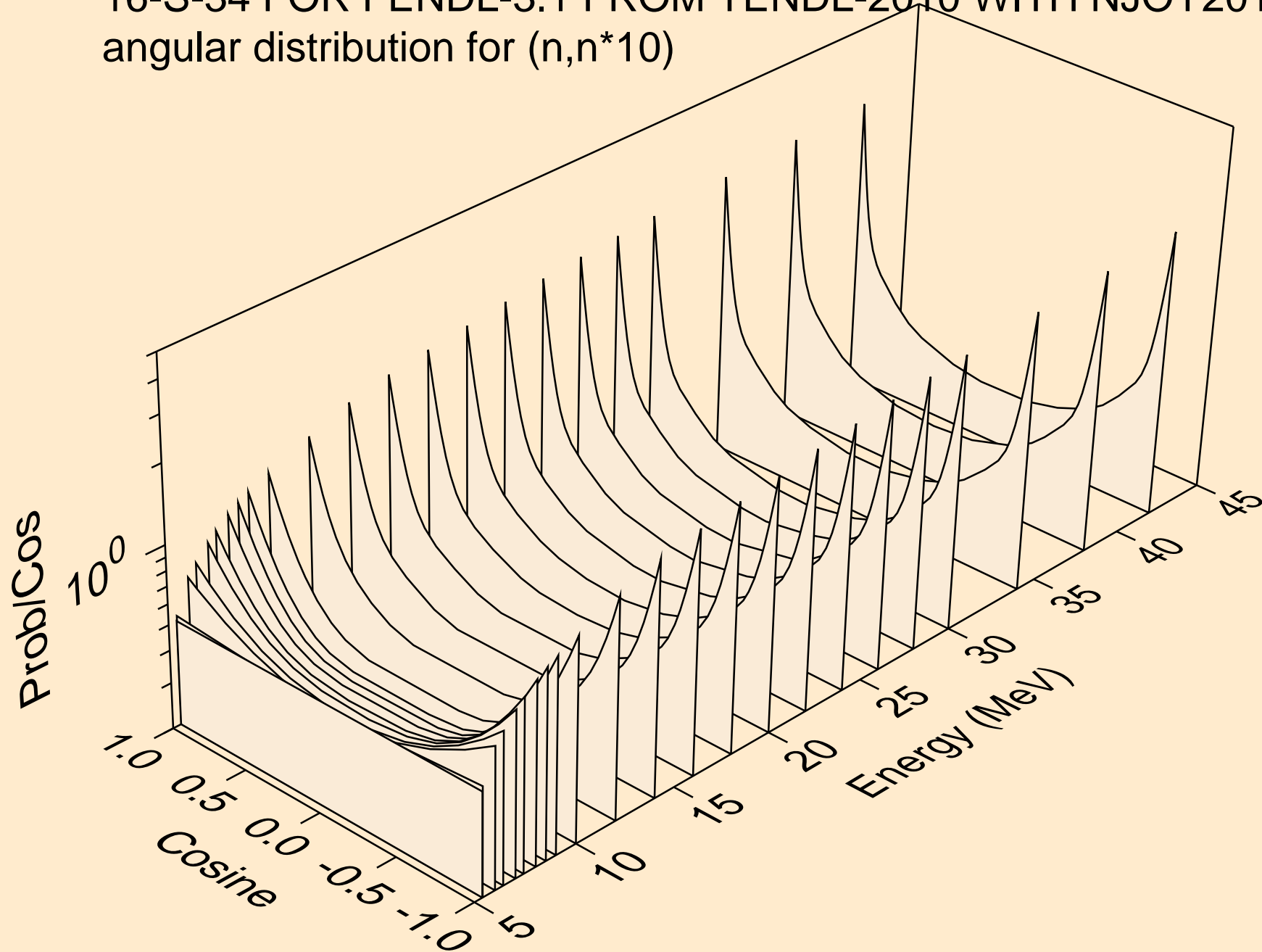

16-S-34 FOR FENDL-3.1 FROM TENDL-2010 WITH NJOY2012.50+
angular distribution for (n,n*11)

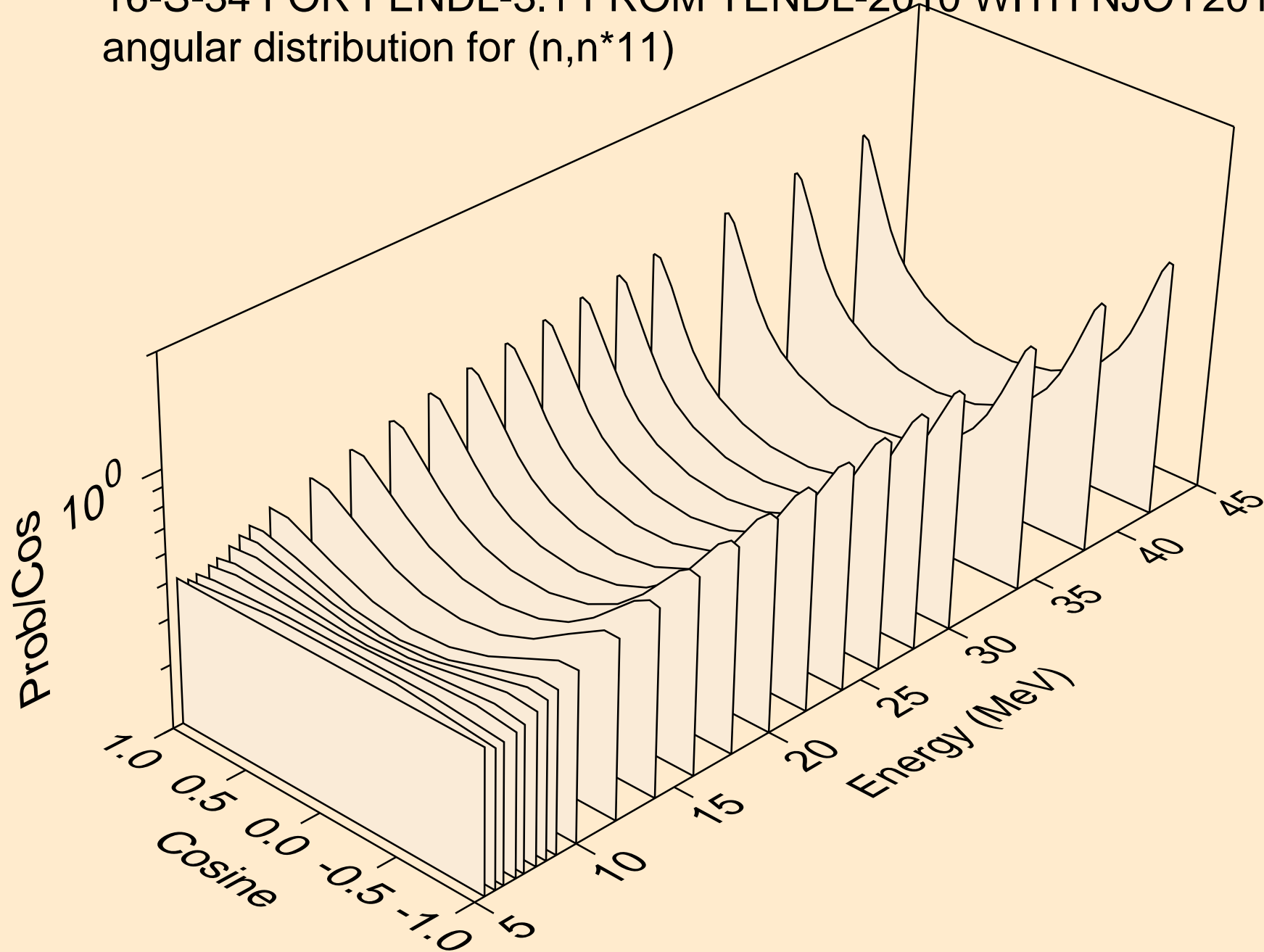

16-S-34 FOR FENDL-3.1 FROM TENDL-2010 WITH NJOY2012.50+
angular distribution for (n,n*12)

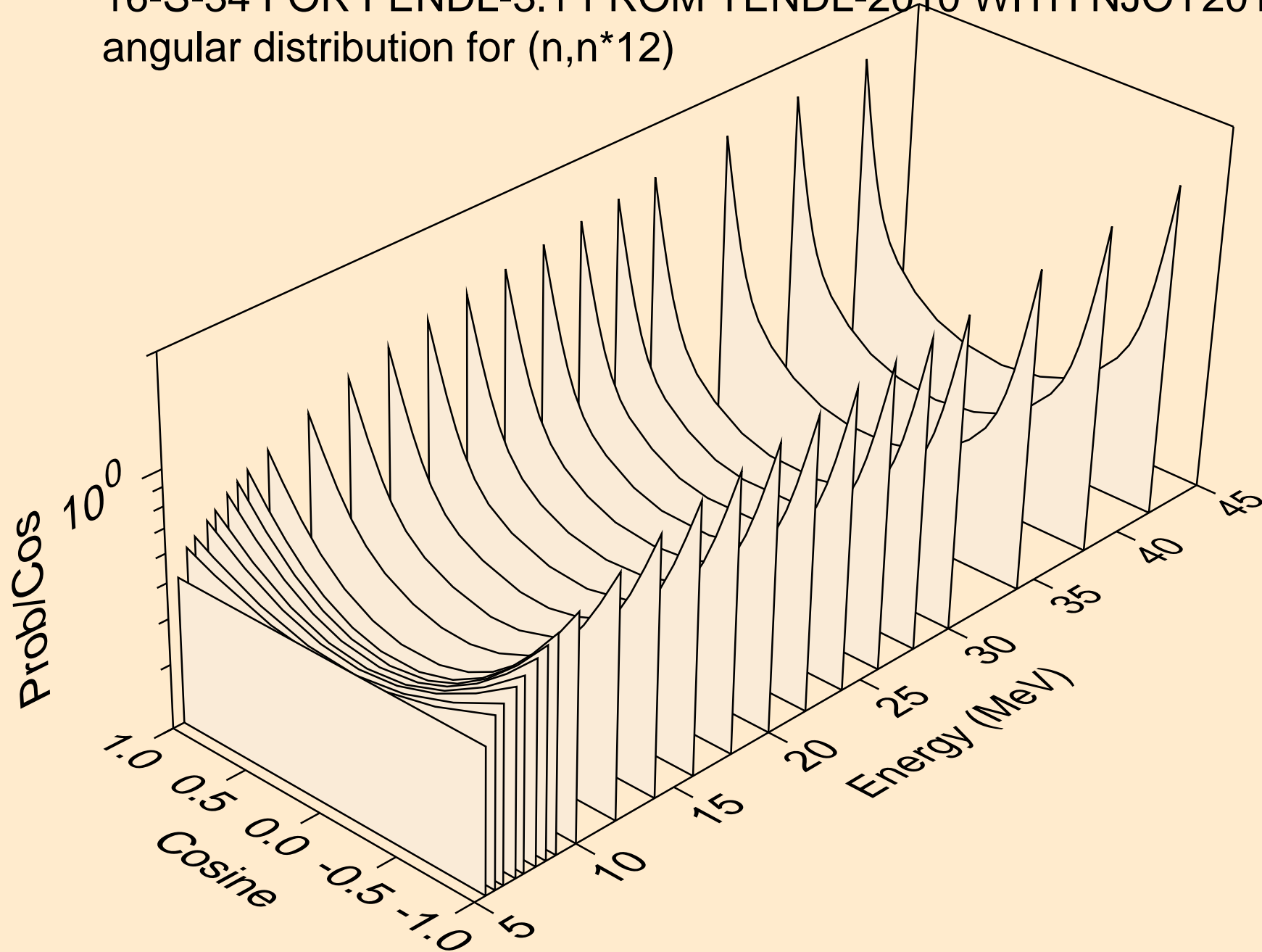

16-S-34 FOR FENDL-3.1 FROM TENDL-2010 WITH NJOY2012.50+
angular distribution for (n,n*13)

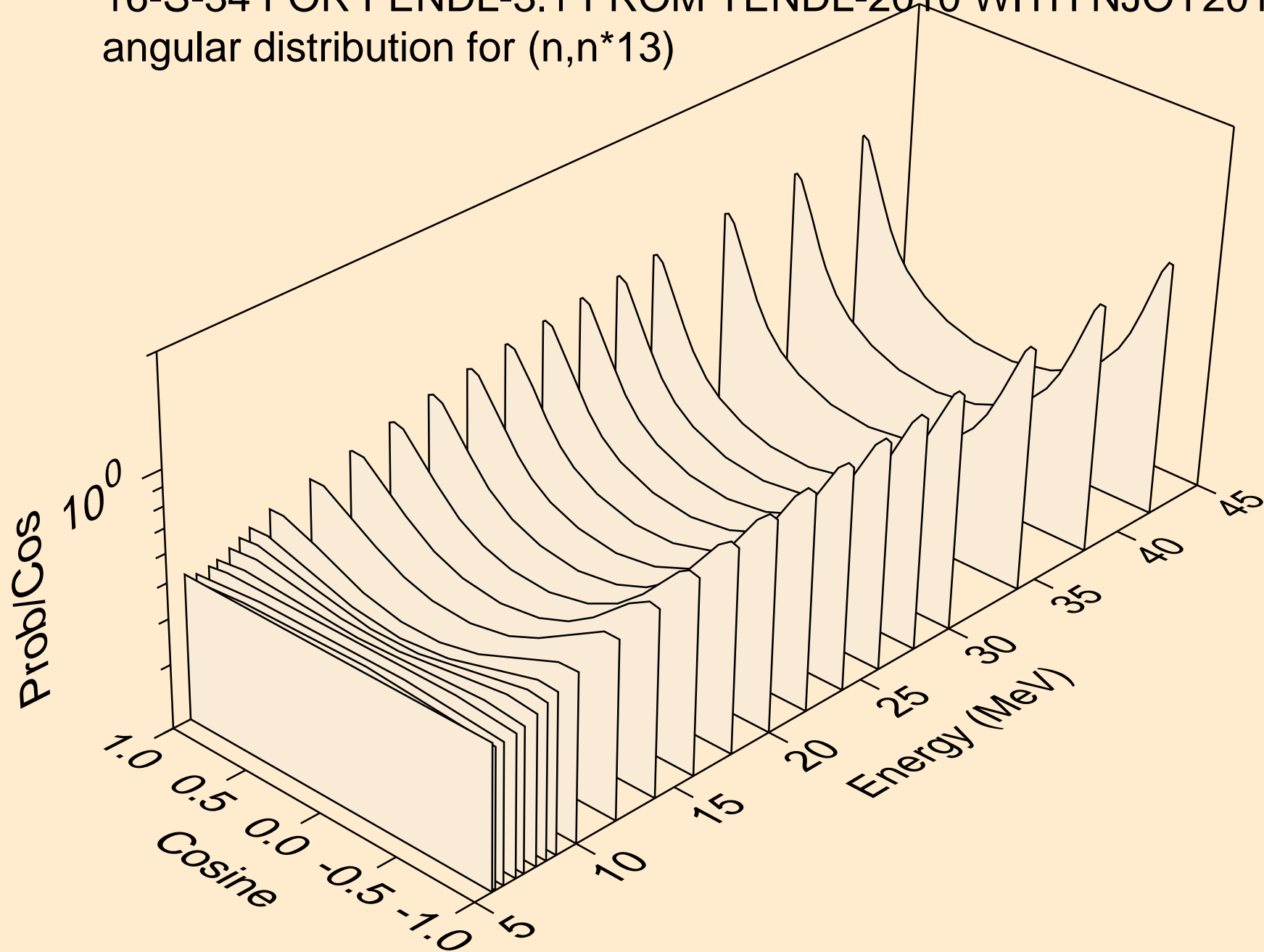

16-S-34 FOR FENDL-3.1 FROM TENDL-2010 WITH NJOY2012.50+
angular distribution for (n,n*14)

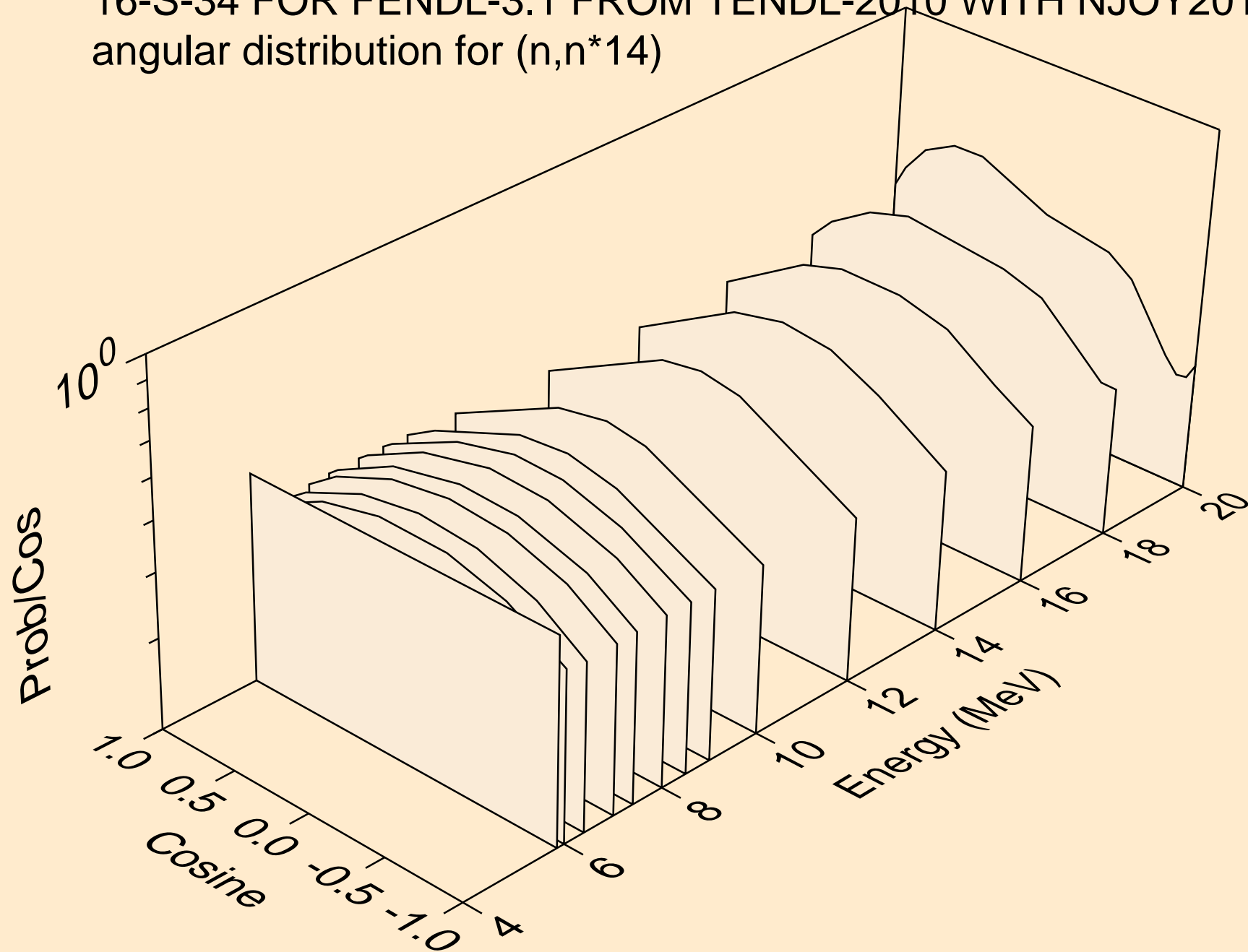

16-S-34 FOR FENDL-3.1 FROM TENDL-2010 WITH NJOY2012.50+
angular distribution for (n,n*14)

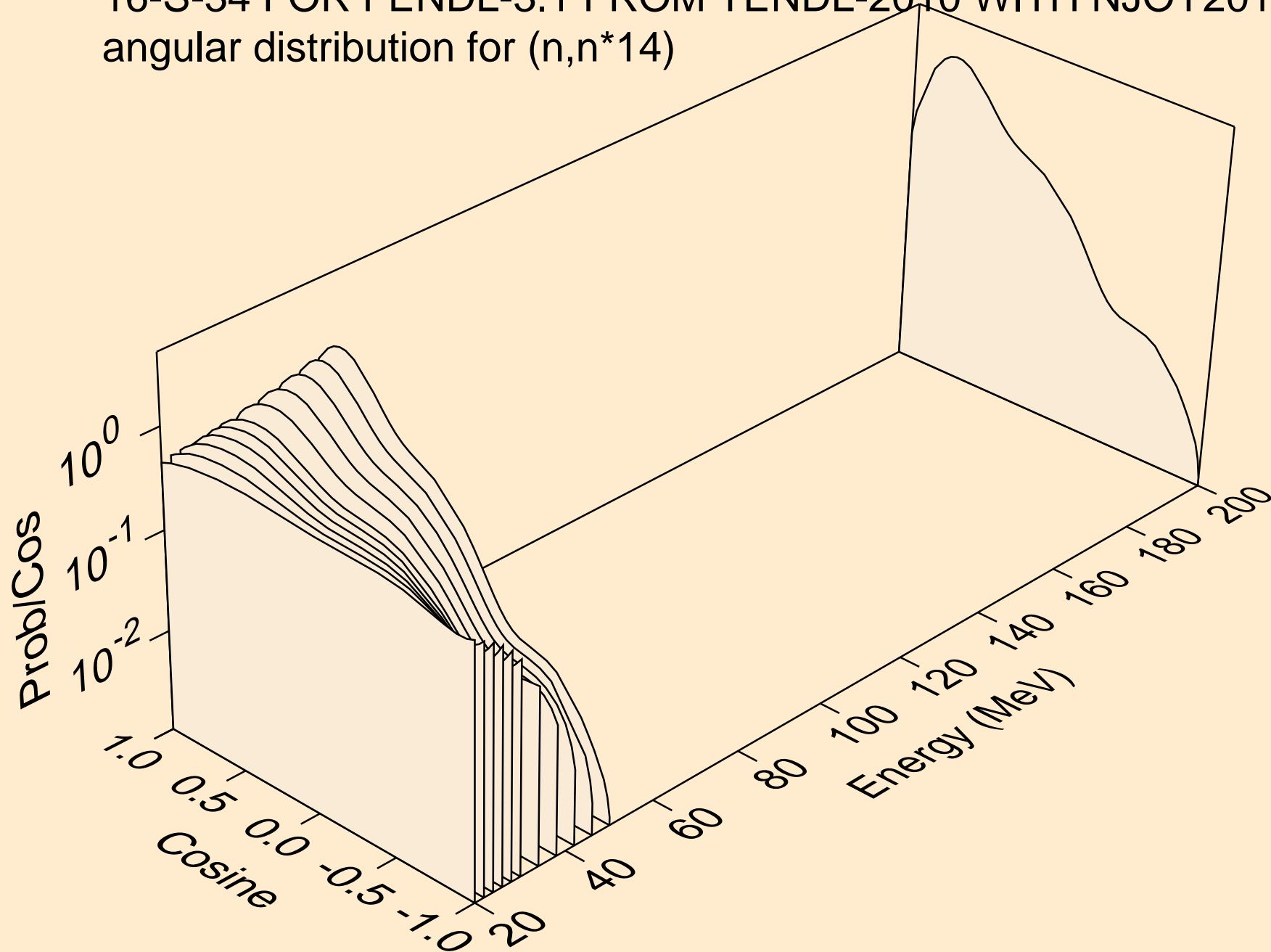

16-S-34 FOR FENDL-3.1 FROM TENDL-2010 WITH NJOY2012.50+
angular distribution for (n,n*15)

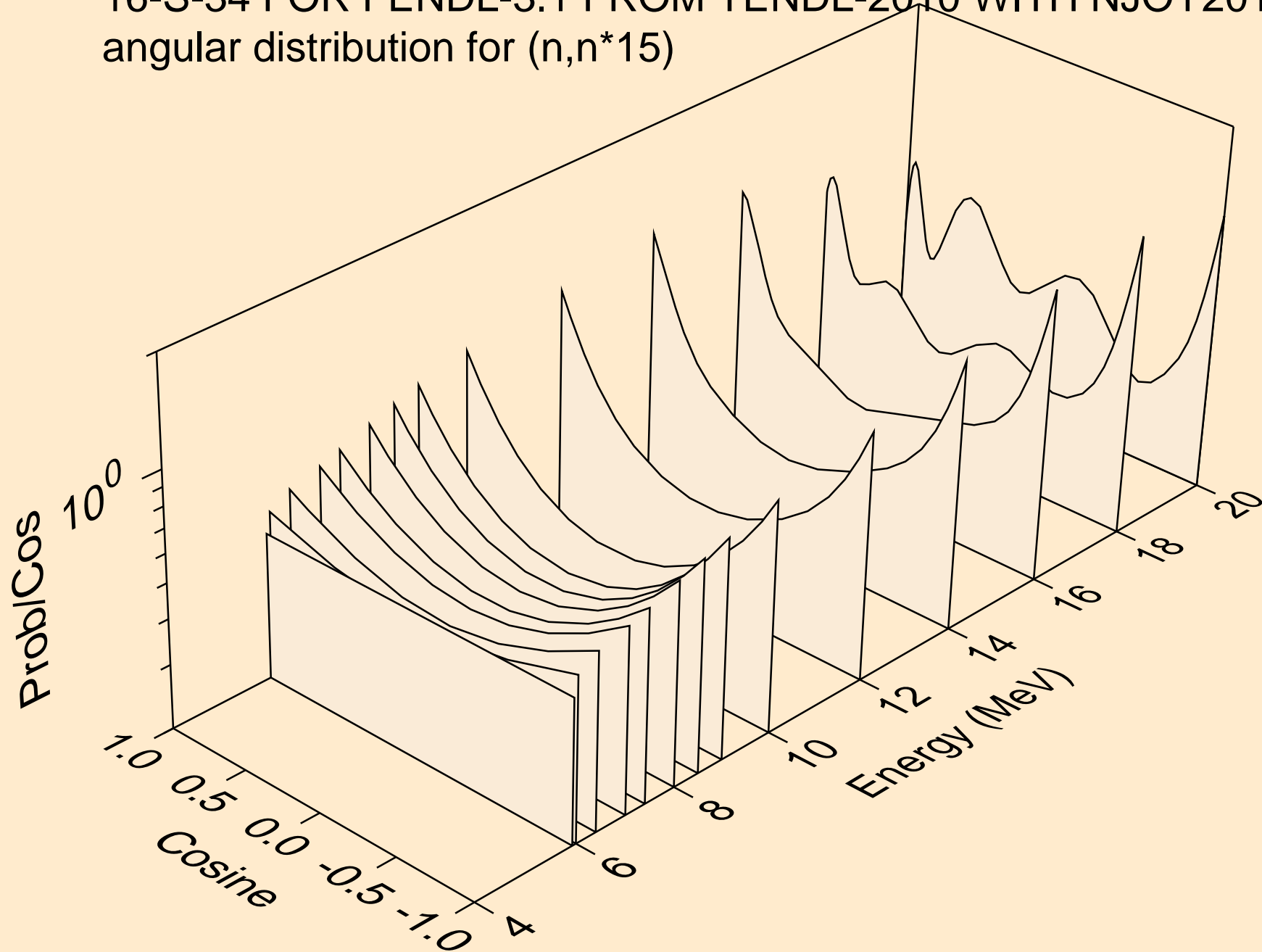

16-S-34 FOR FENDL-3.1 FROM TENDL-2010 WITH NJOY2012.50+
angular distribution for (n,n*15)

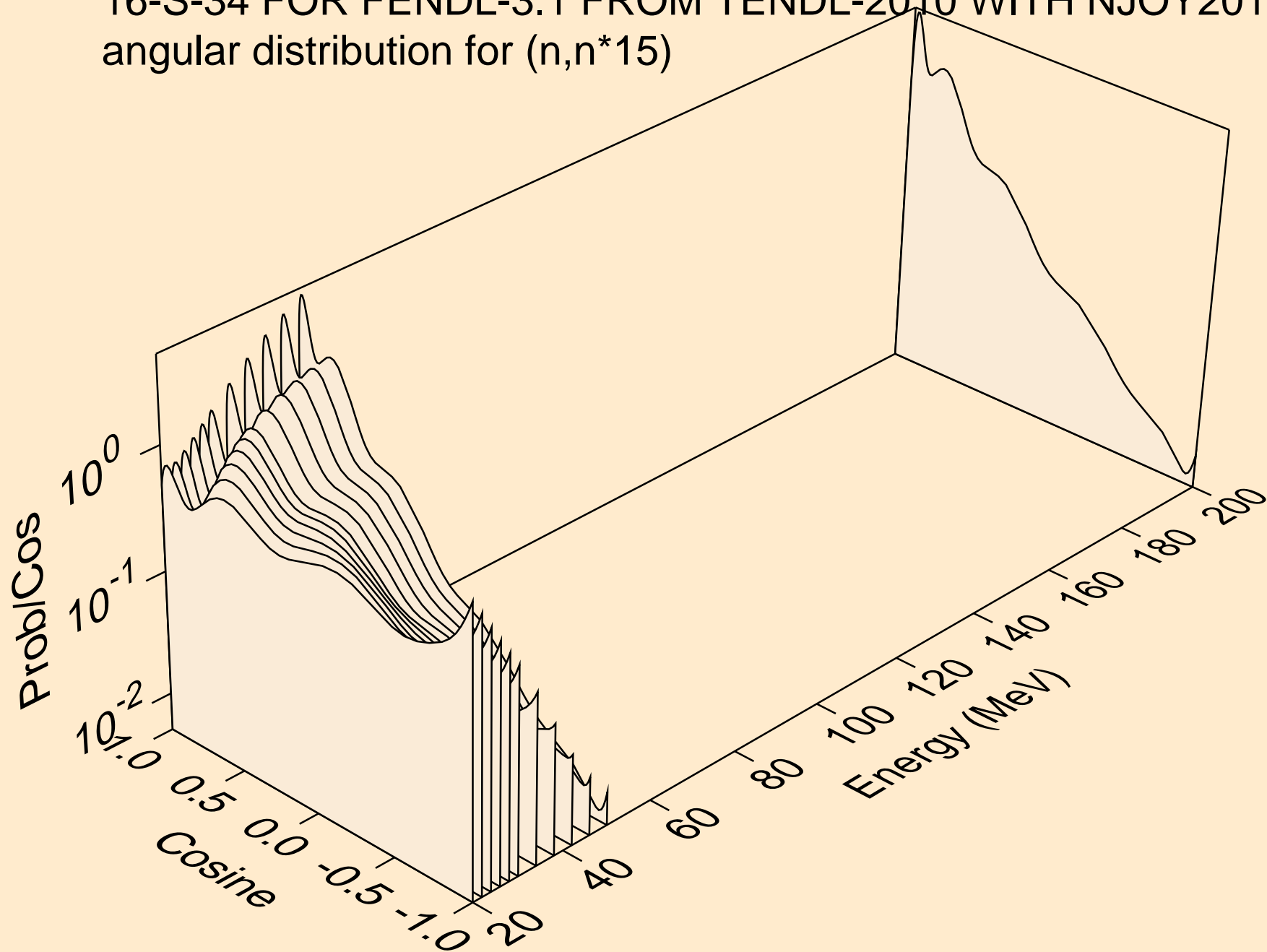

16-S-34 FOR FENDL-3.1 FROM TENDL-2010 WITH NJOY2012.50+
angular distribution for (n,n*16)

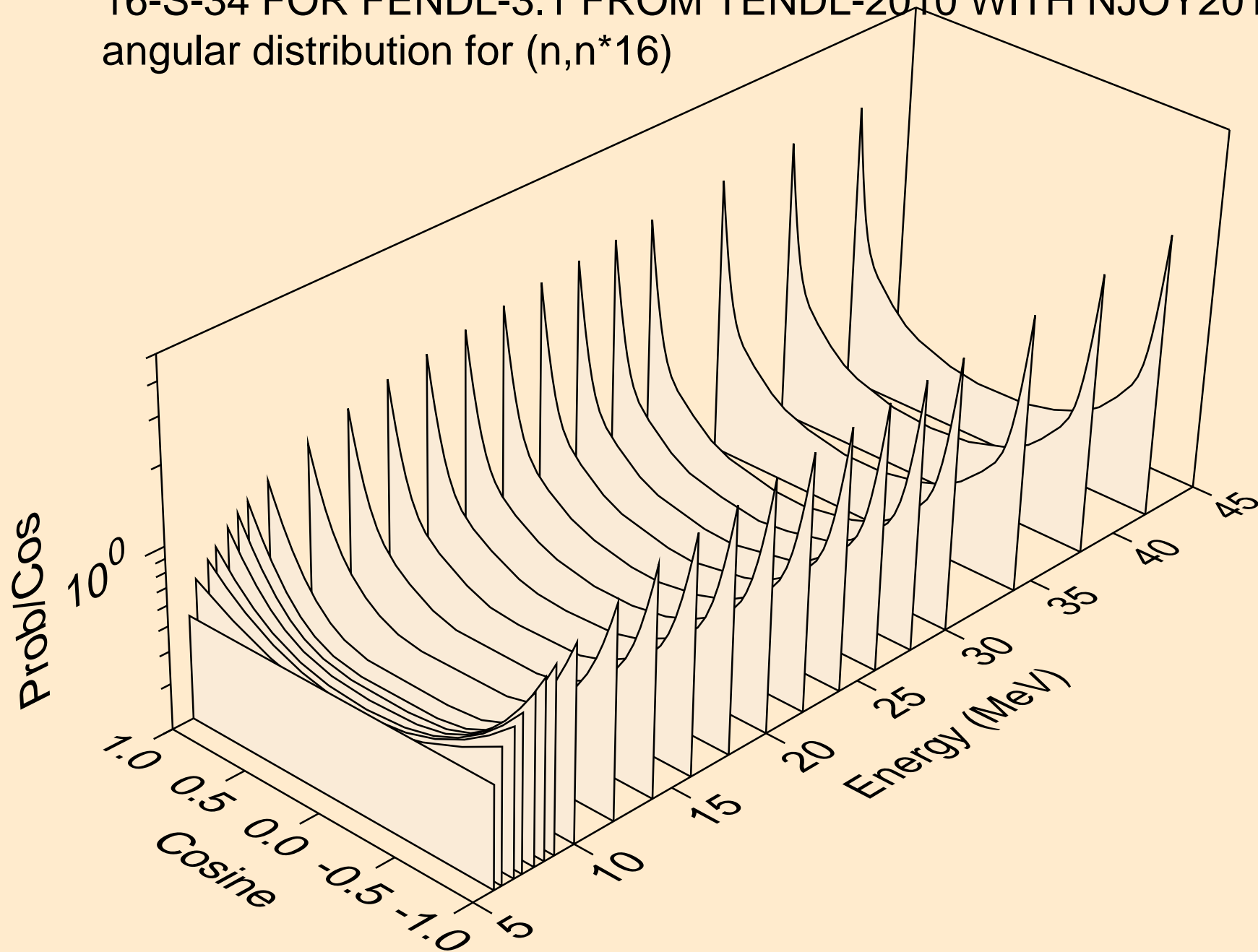

16-S-34 FOR FENDL-3.1 FROM TENDL-2010 WITH NJOY2012.50+
angular distribution for (n,n*17)

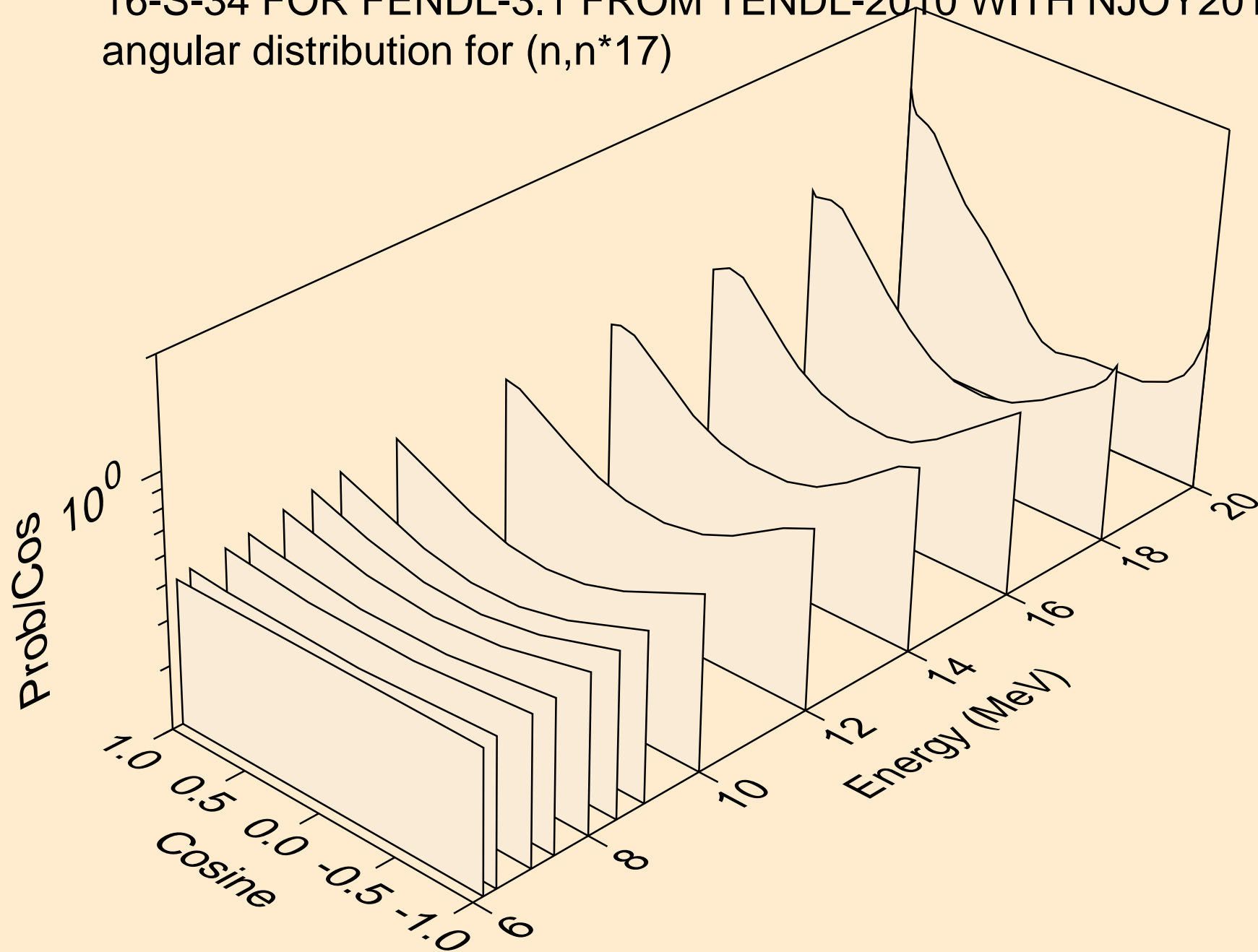

16-S-34 FOR FENDL-3.1 FROM TENDL-2010 WITH NJOY2012.50+
angular distribution for (n,n*17)

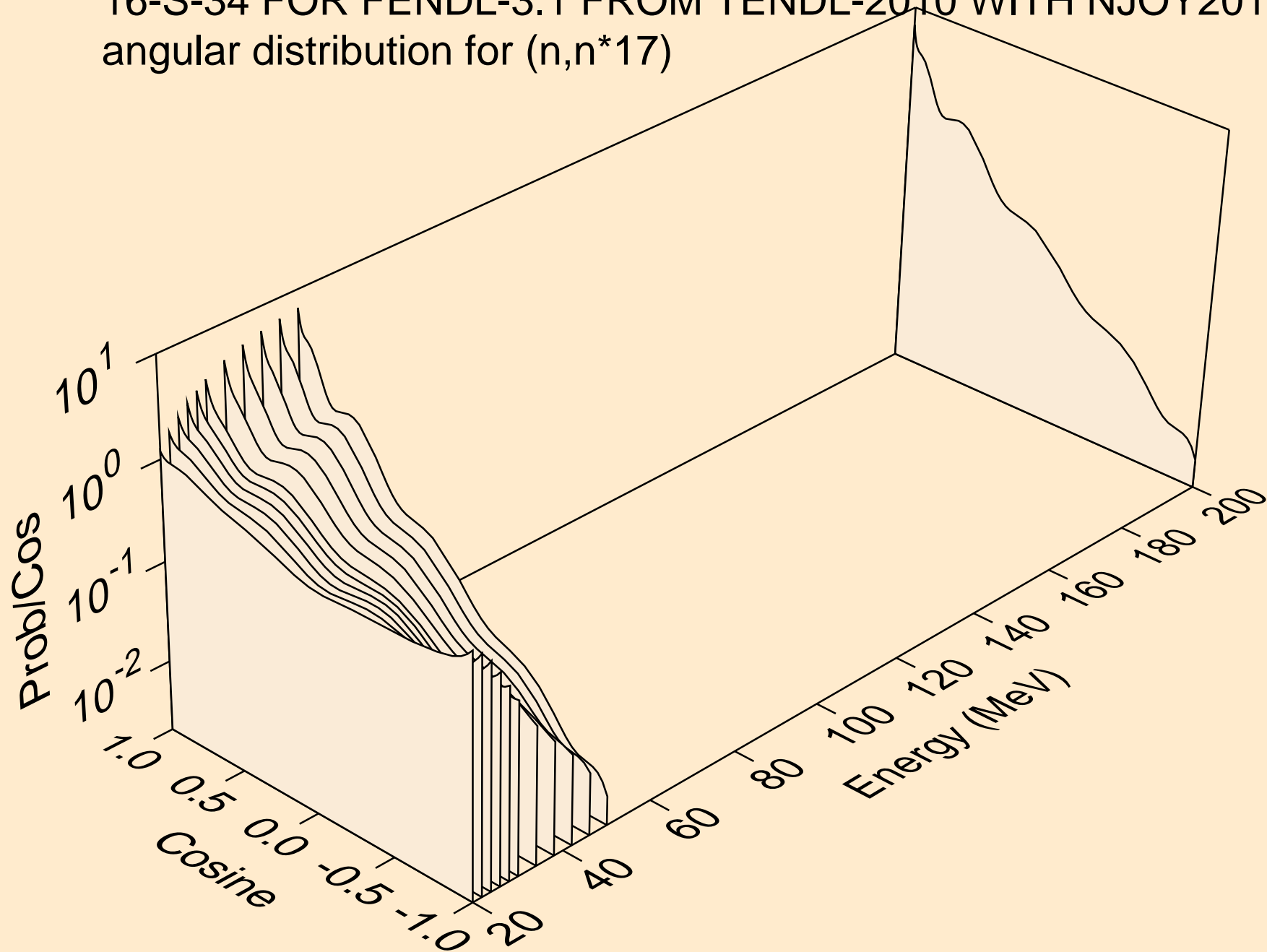

16-S-34 FOR FENDL-3.1 FROM TENDL-2010 WITH NJOY2012.50+
angular distribution for (n,n*18)

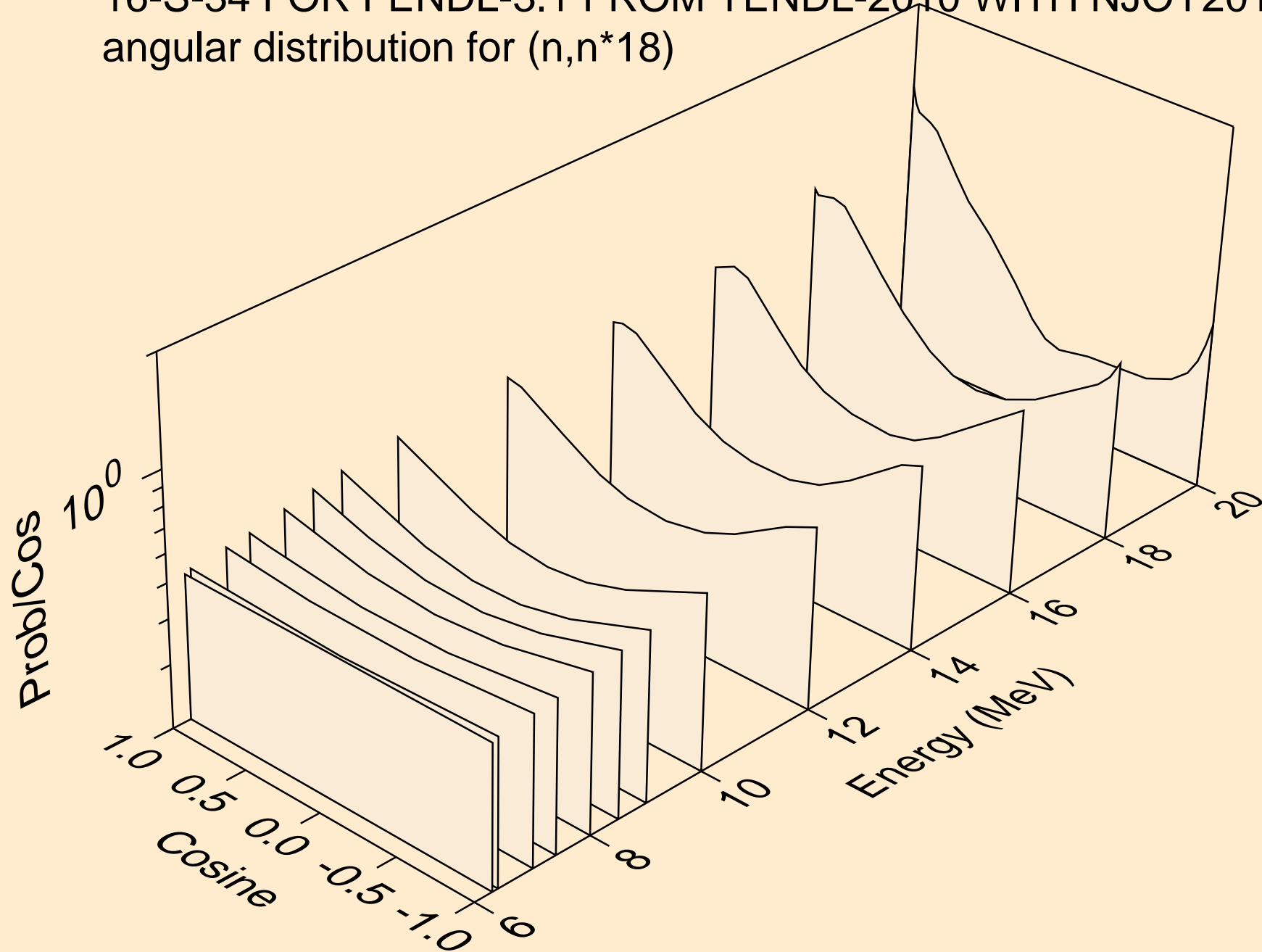

16-S-34 FOR FENDL-3.1 FROM TENDL-2010 WITH NJOY2012.50+
angular distribution for (n,n*18)

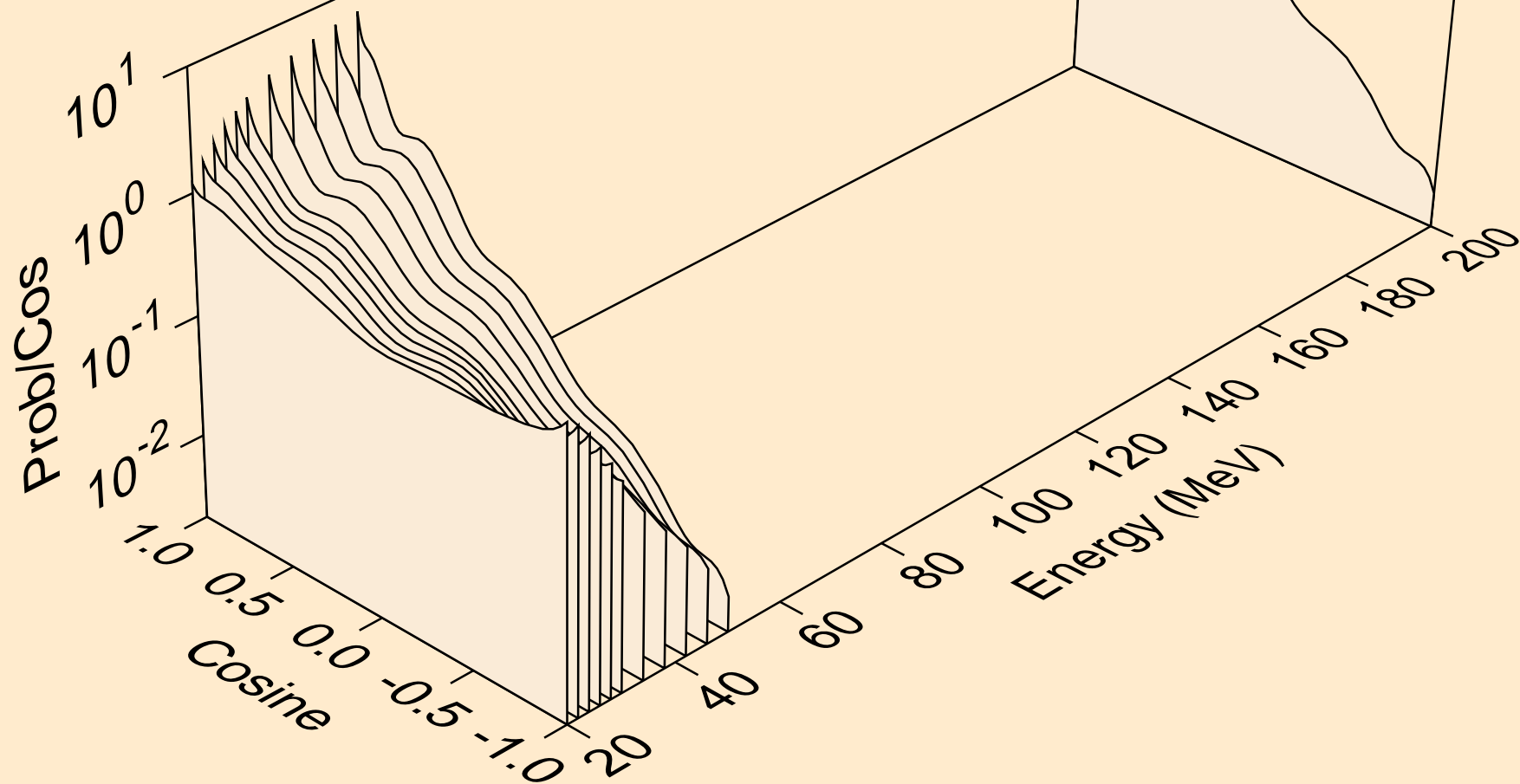

16-S-34 FOR FENDL-3.1 FROM TENDL-2010 WITH NJOY2012.50+
angular distribution for (n,n*19)

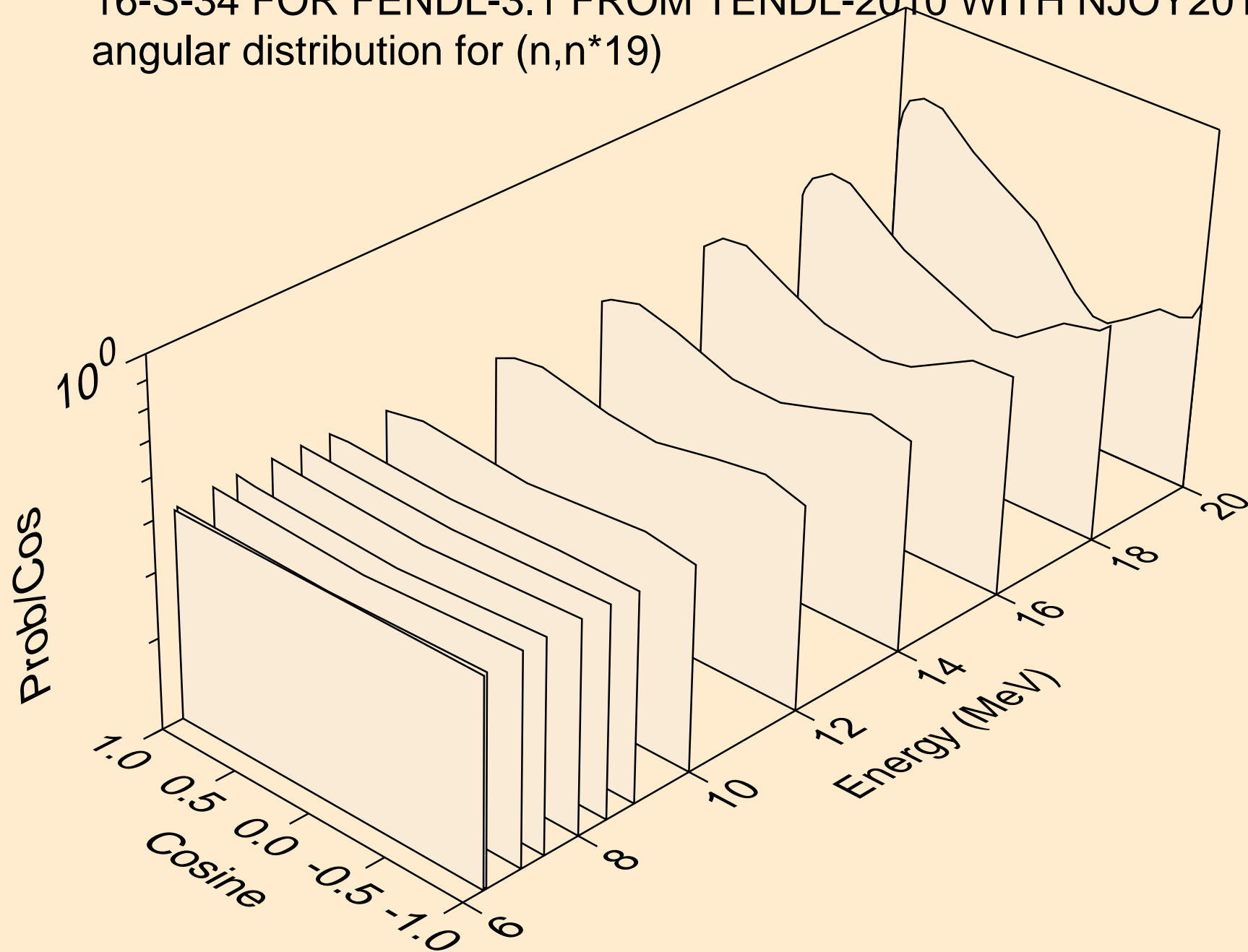

16-S-34 FOR FENDL-3.1 FROM TENDL-2010 WITH NJOY2012.50+
angular distribution for (n,n*19)

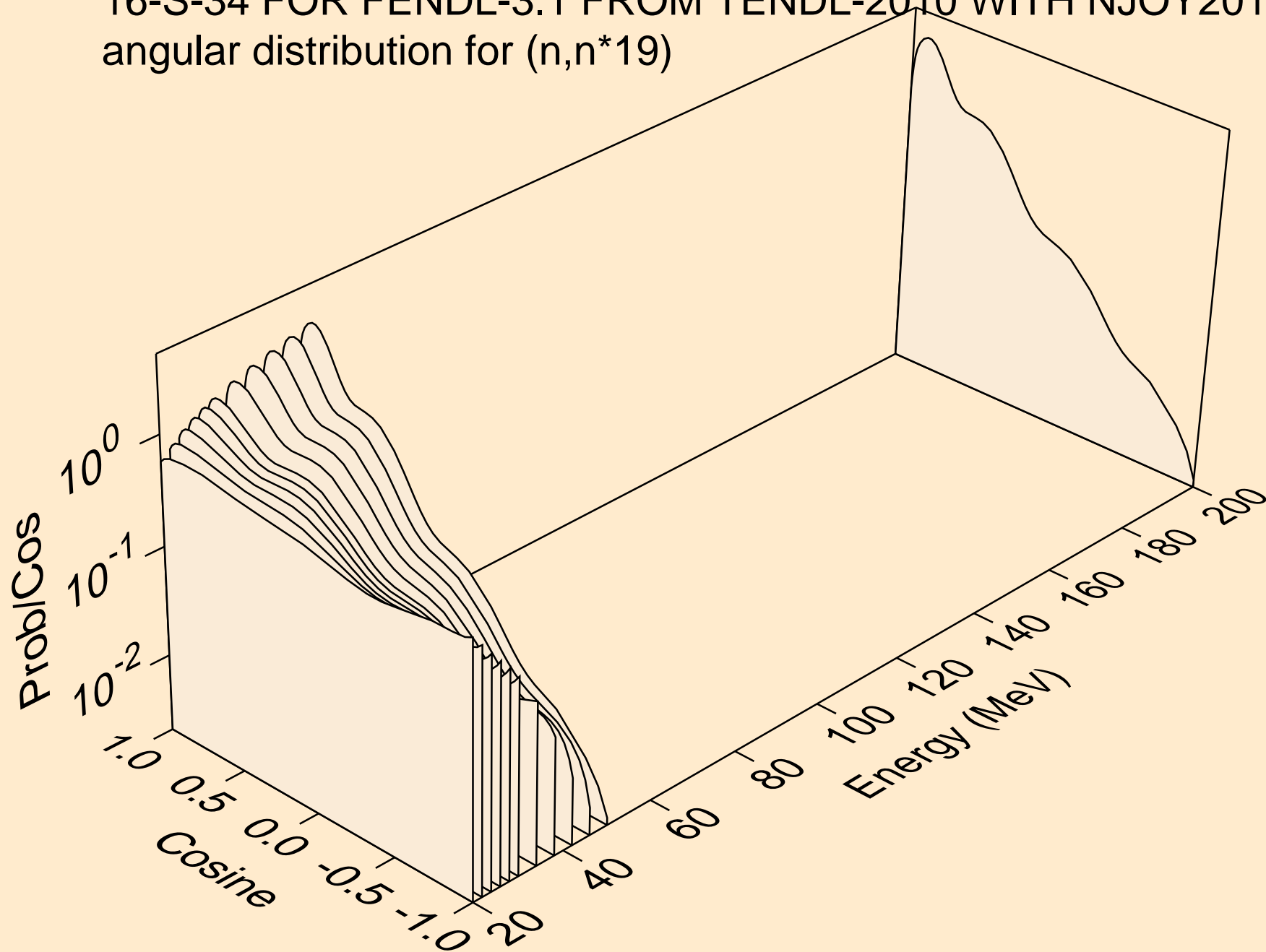

16-S-34 FOR FENDL-3.1 FROM TENDL-2010 WITH NJOY2012.50+
angular distribution for (n,n*20)

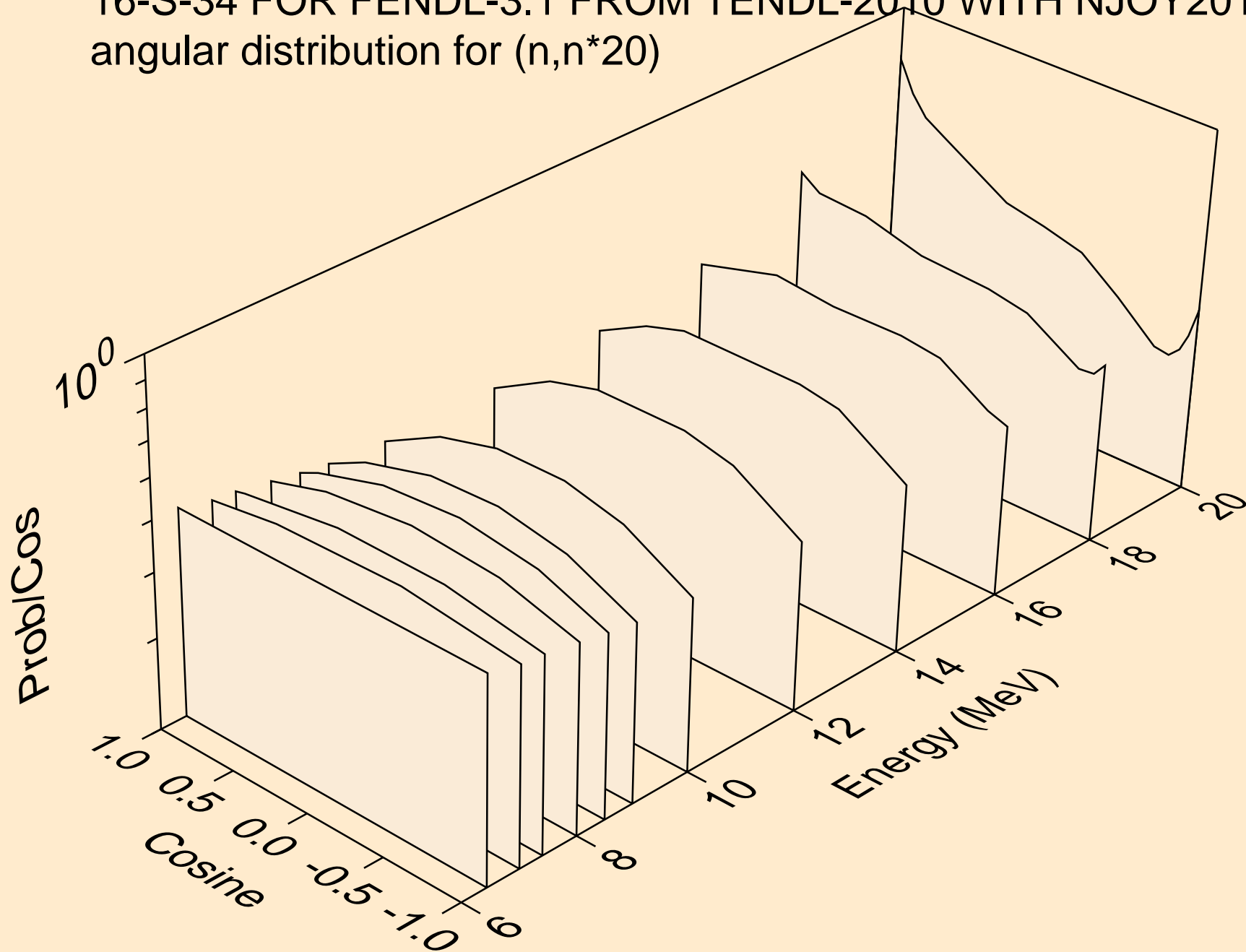

16-S-34 FOR FENDL-3.1 FROM TENDL-2010 WITH NJOY2012.50+
angular distribution for (n,n*20)

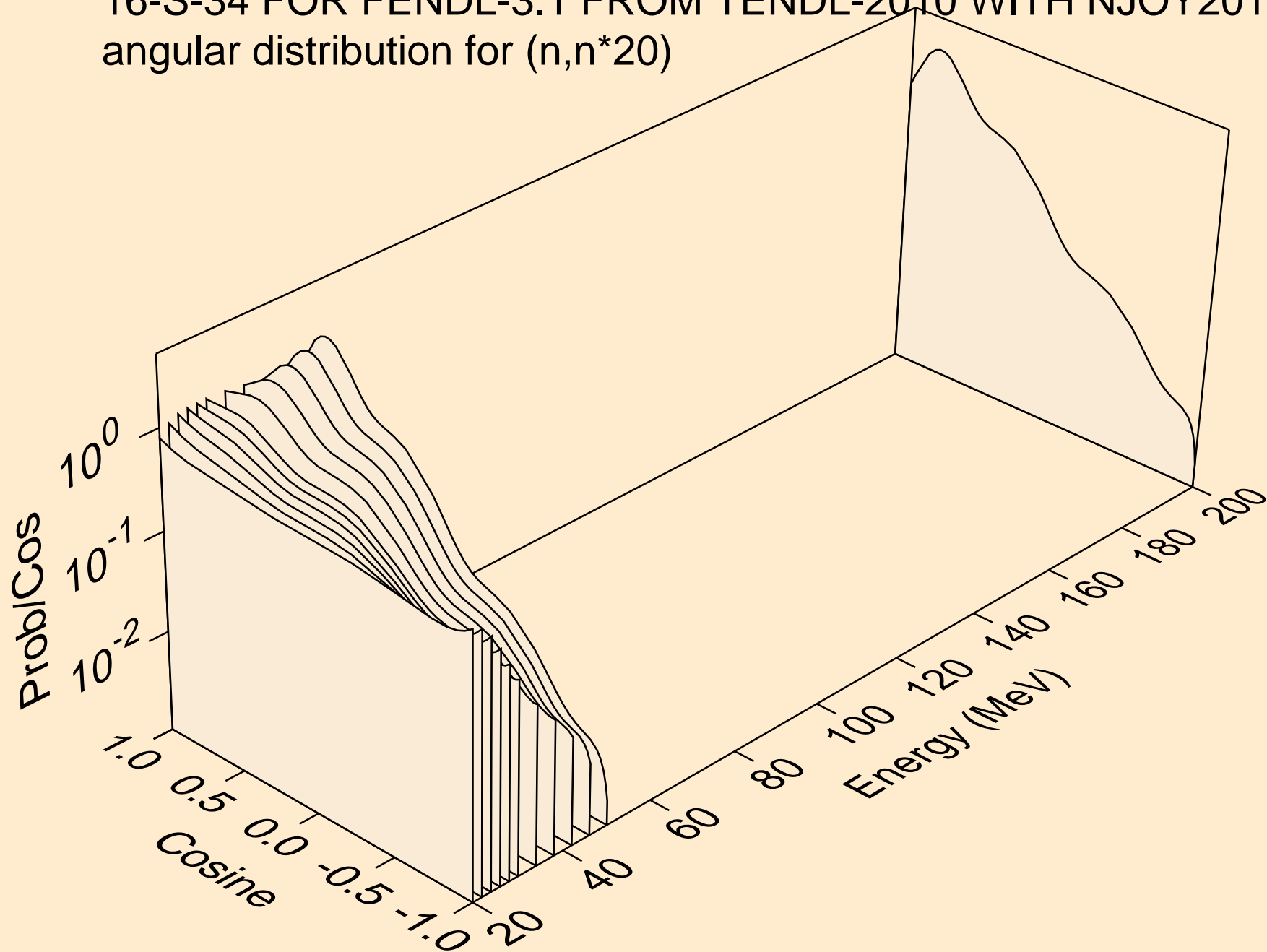

16-S-34 FOR FENDL-3.1 FROM TENDL-2010 WITH NJOY2012.50+
angular distribution for (n,n*21)

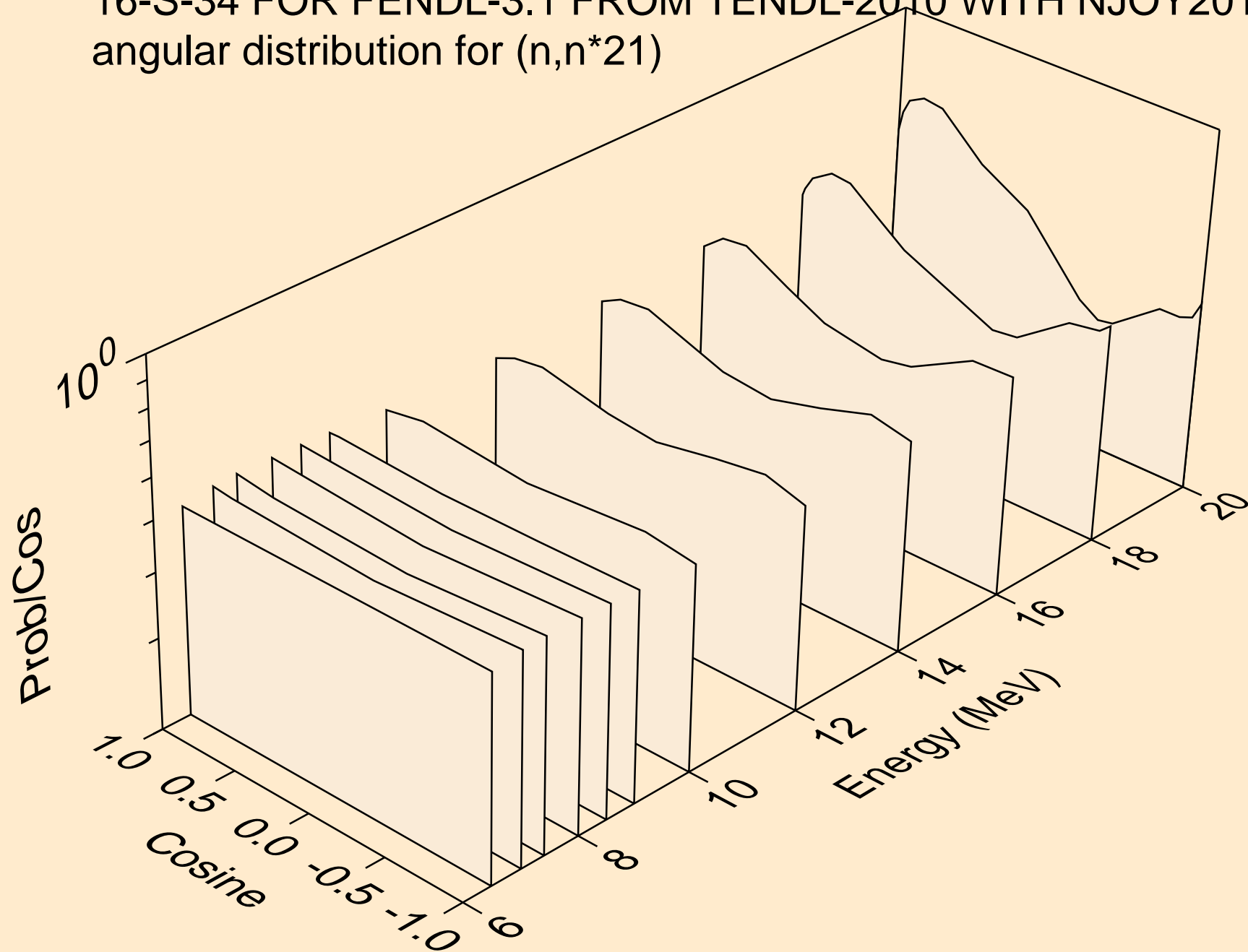

16-S-34 FOR FENDL-3.1 FROM TENDL-2010 WITH NJOY2012.50+
angular distribution for (n,n*21)

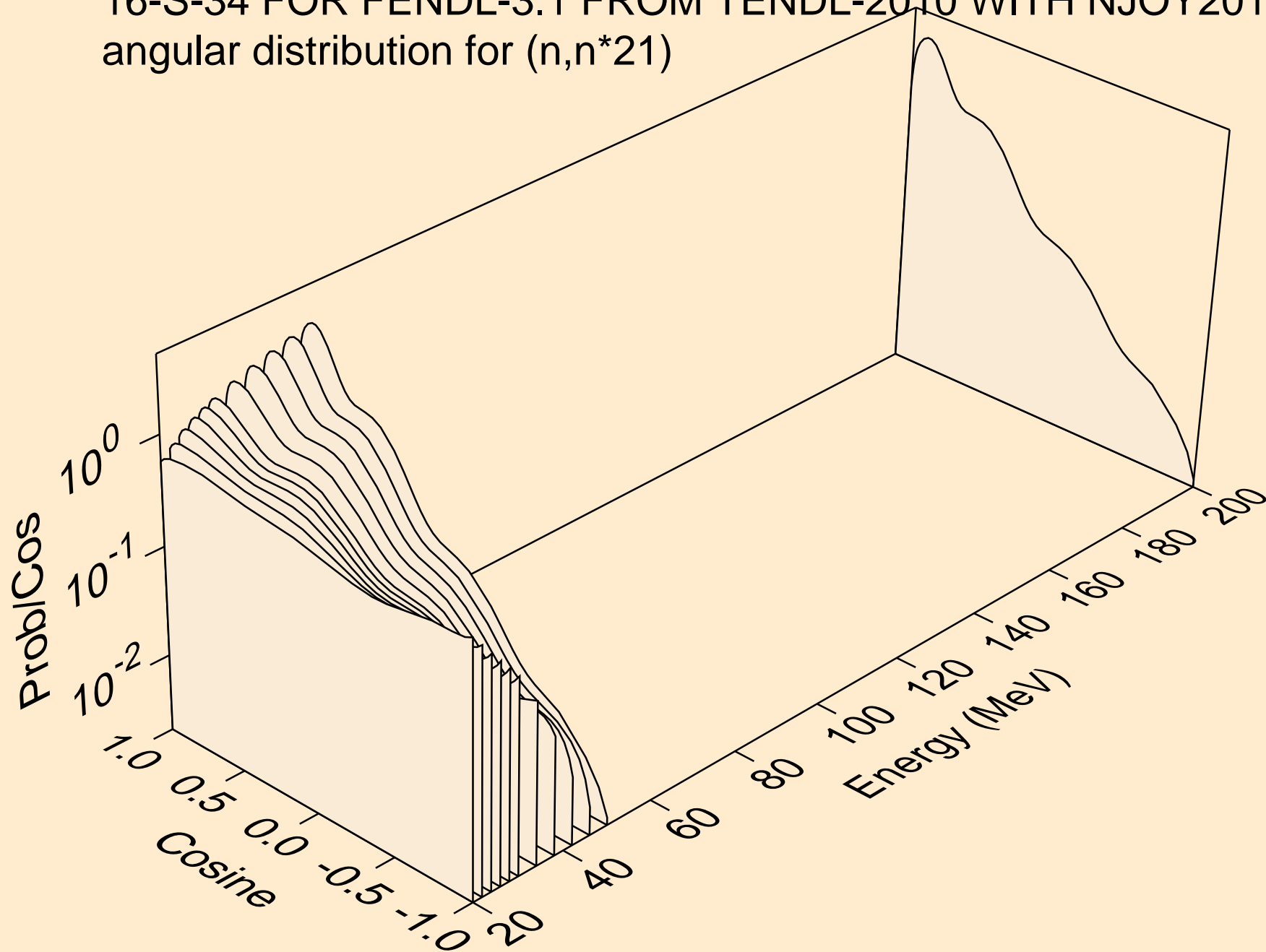

16-S-34 FOR FENDL-3.1 FROM TENDL-2010 WITH NJOY2012.50+
angular distribution for (n,n*22)

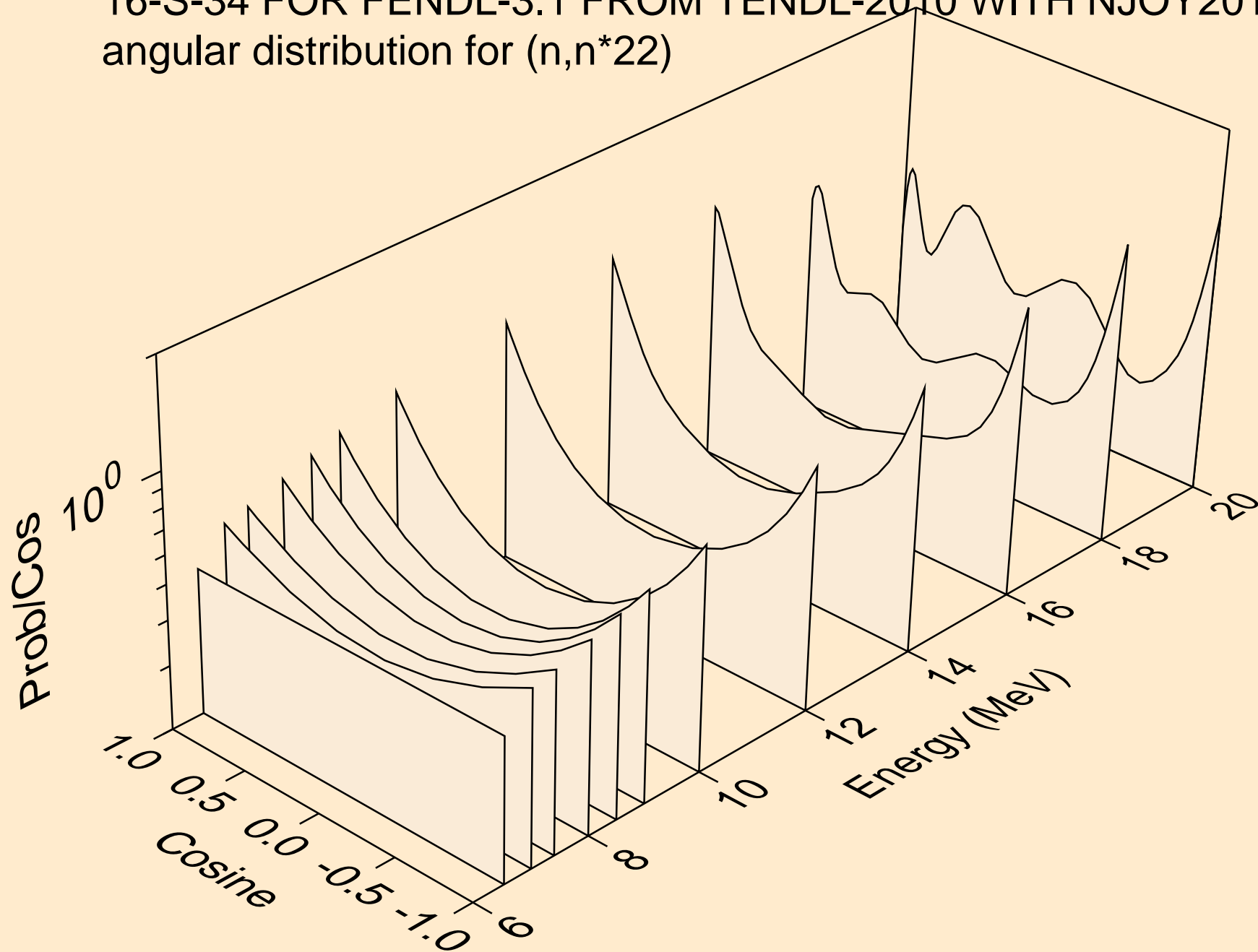

16-S-34 FOR FENDL-3.1 FROM TENDL-2010 WITH NJOY2012.50+
angular distribution for (n,n*22)

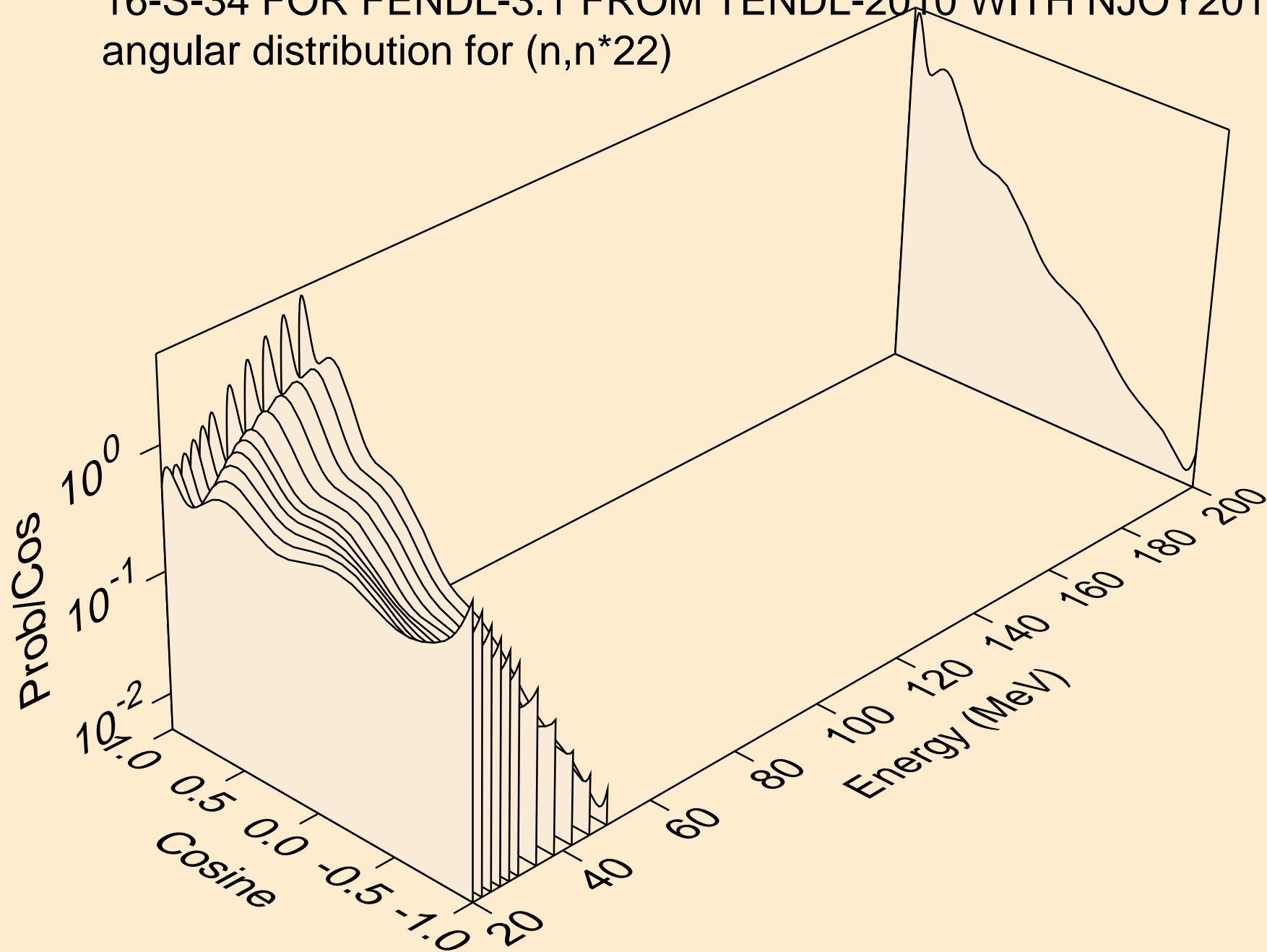

16-S-34 FOR FENDL-3.1 FROM TENDL-2010 WITH NJOY2012.50+
angular distribution for (n,n*23)

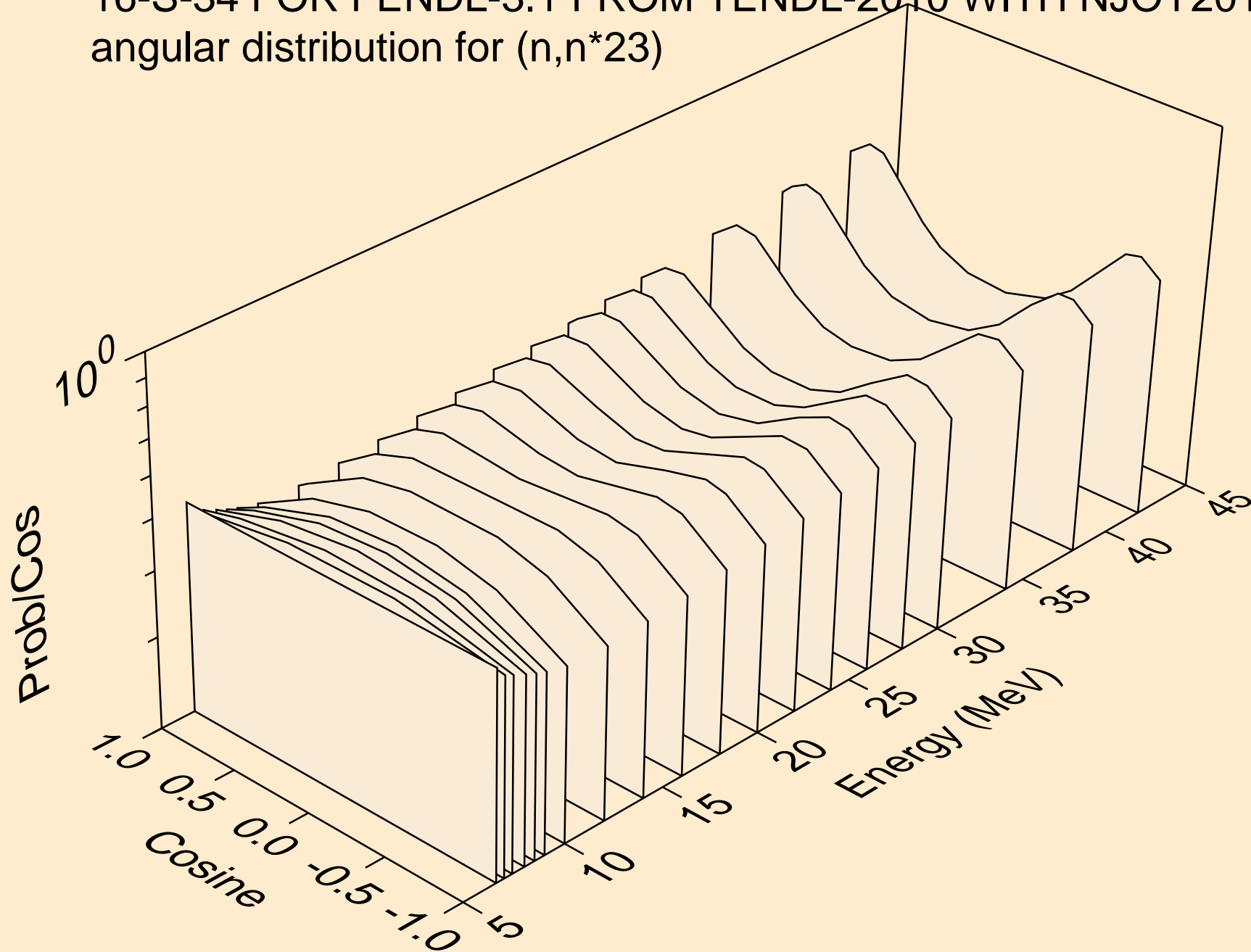

16-S-34 FOR FENDL-3.1 FROM TENDL-2010 WITH NJOY2012.50+
angular distribution for (n,n*24)

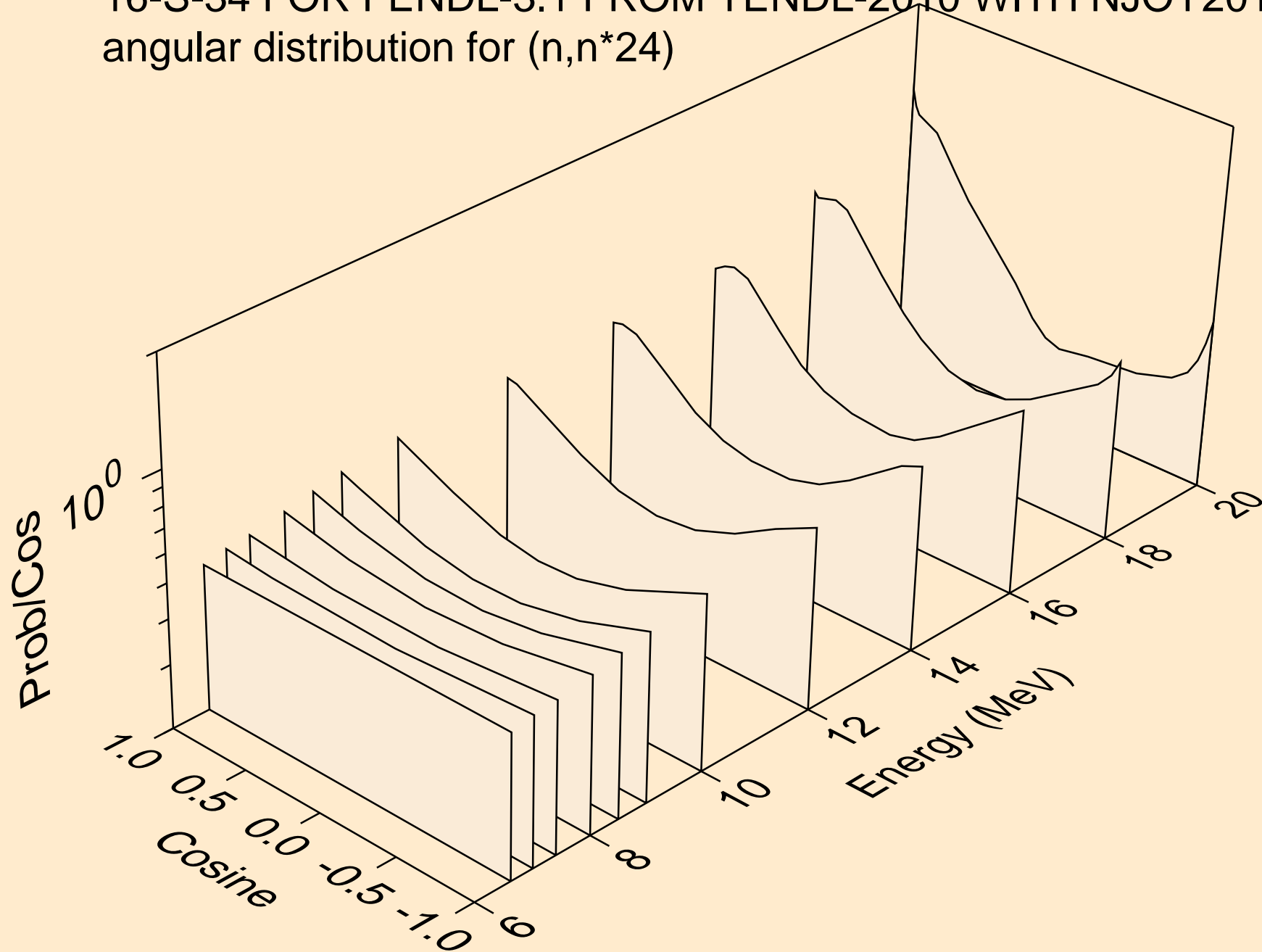

16-S-34 FOR FENDL-3.1 FROM TENDL-2010 WITH NJOY2012.50+
angular distribution for (n,n*24)

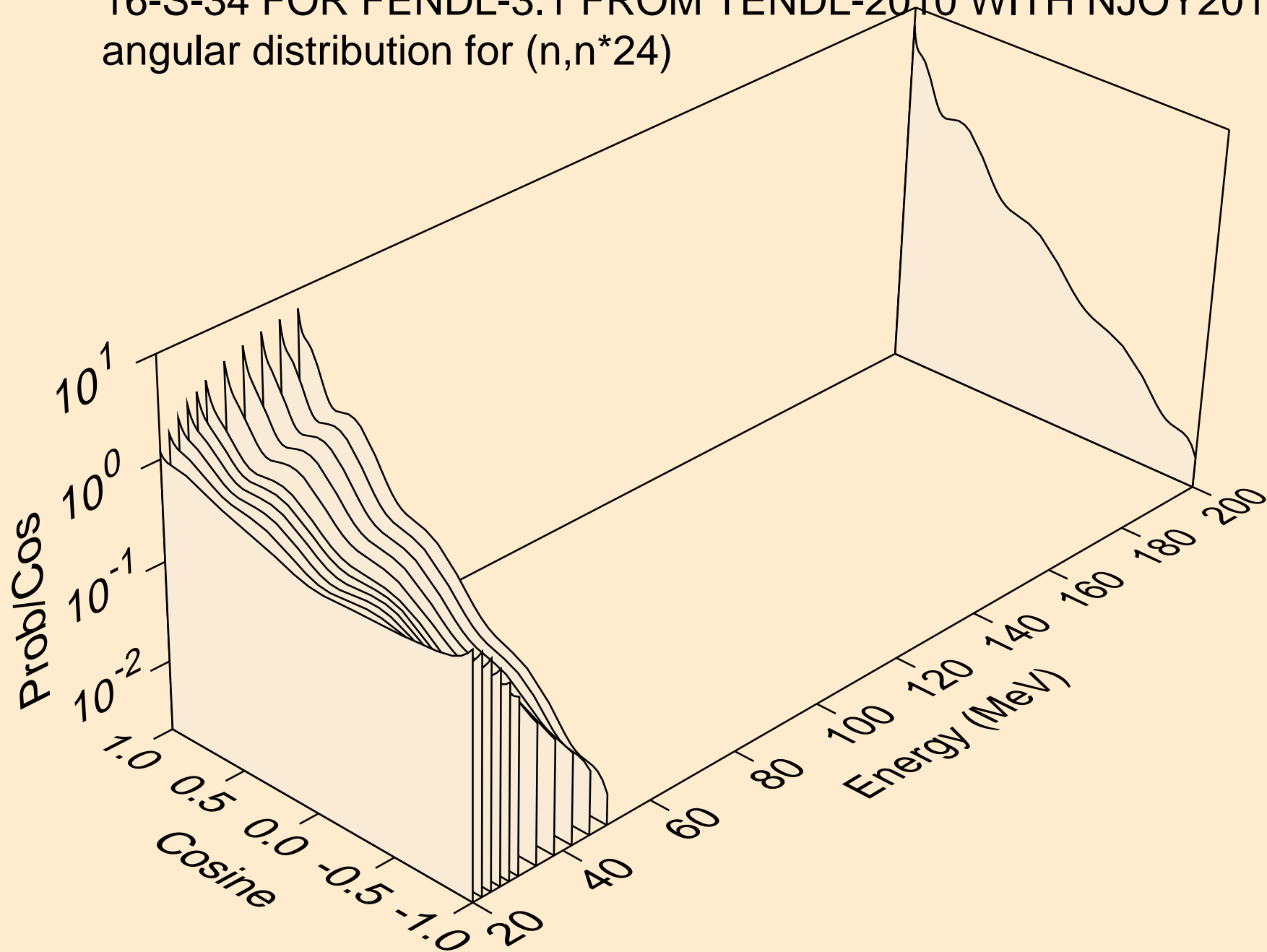

16-S-34 FOR FENDL-3.1 FROM TENDL-2010 WITH NJOY2012.50+
angular distribution for (n,n*25)

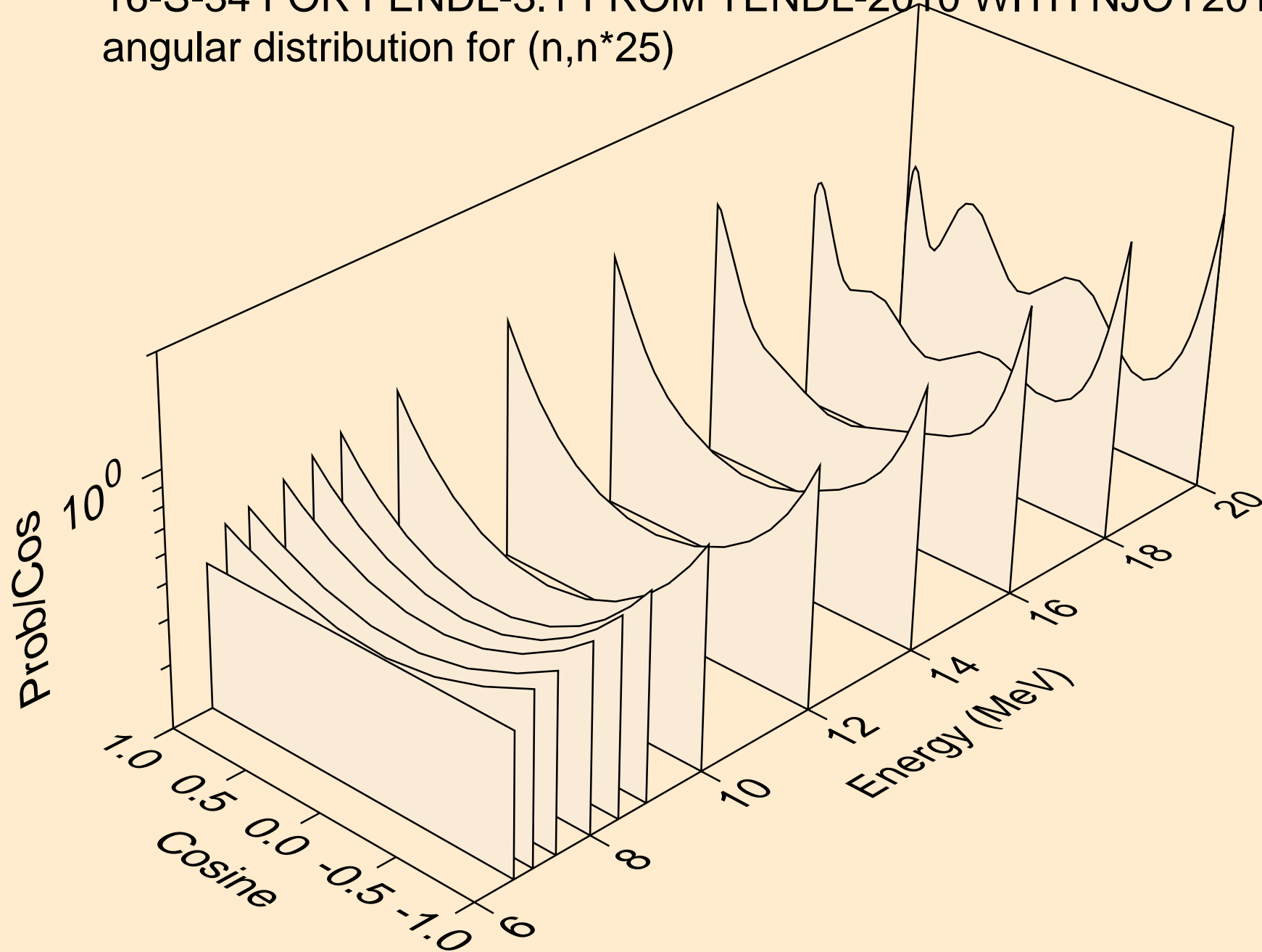

16-S-34 FOR FENDL-3.1 FROM TENDL-2010 WITH NJOY2012.50+
angular distribution for (n,n*25)

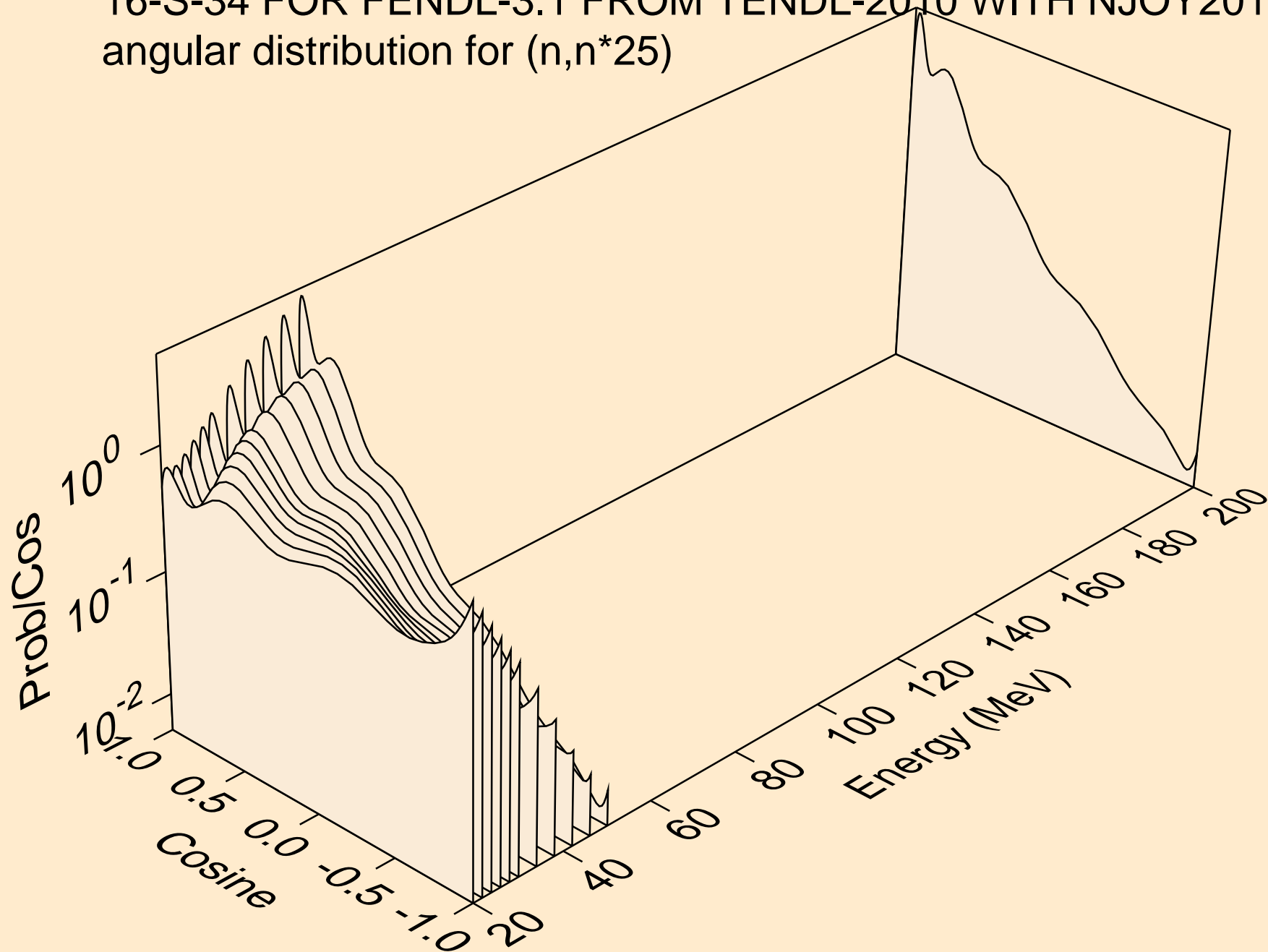

16-S-34 FOR FENDL-3.1 FROM TENDL-2010 WITH NJOY2012.50+
angular distribution for (n,n*26)

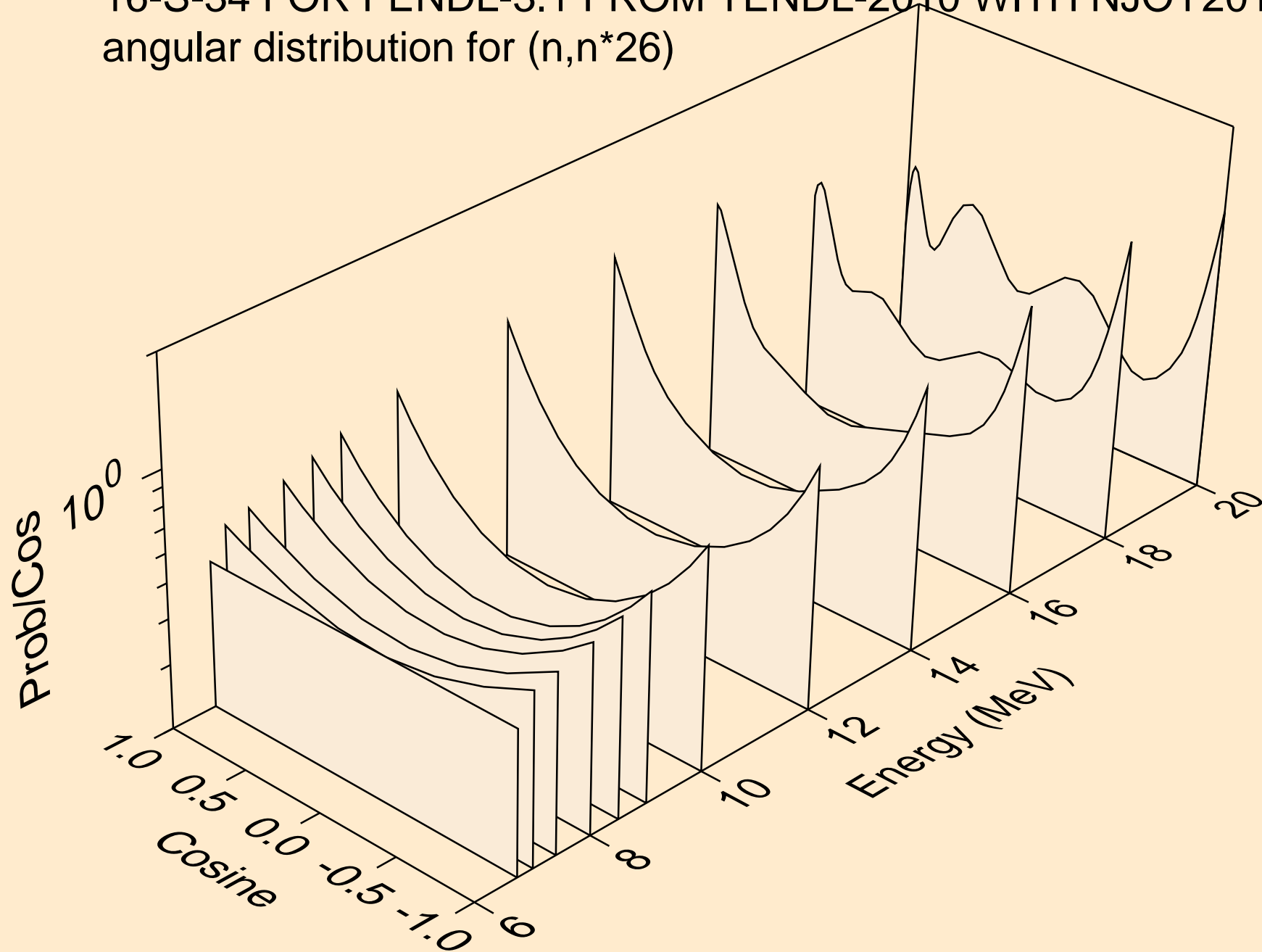

16-S-34 FOR FENDL-3.1 FROM TENDL-2010 WITH NJOY2012.50+
angular distribution for (n,n*26)

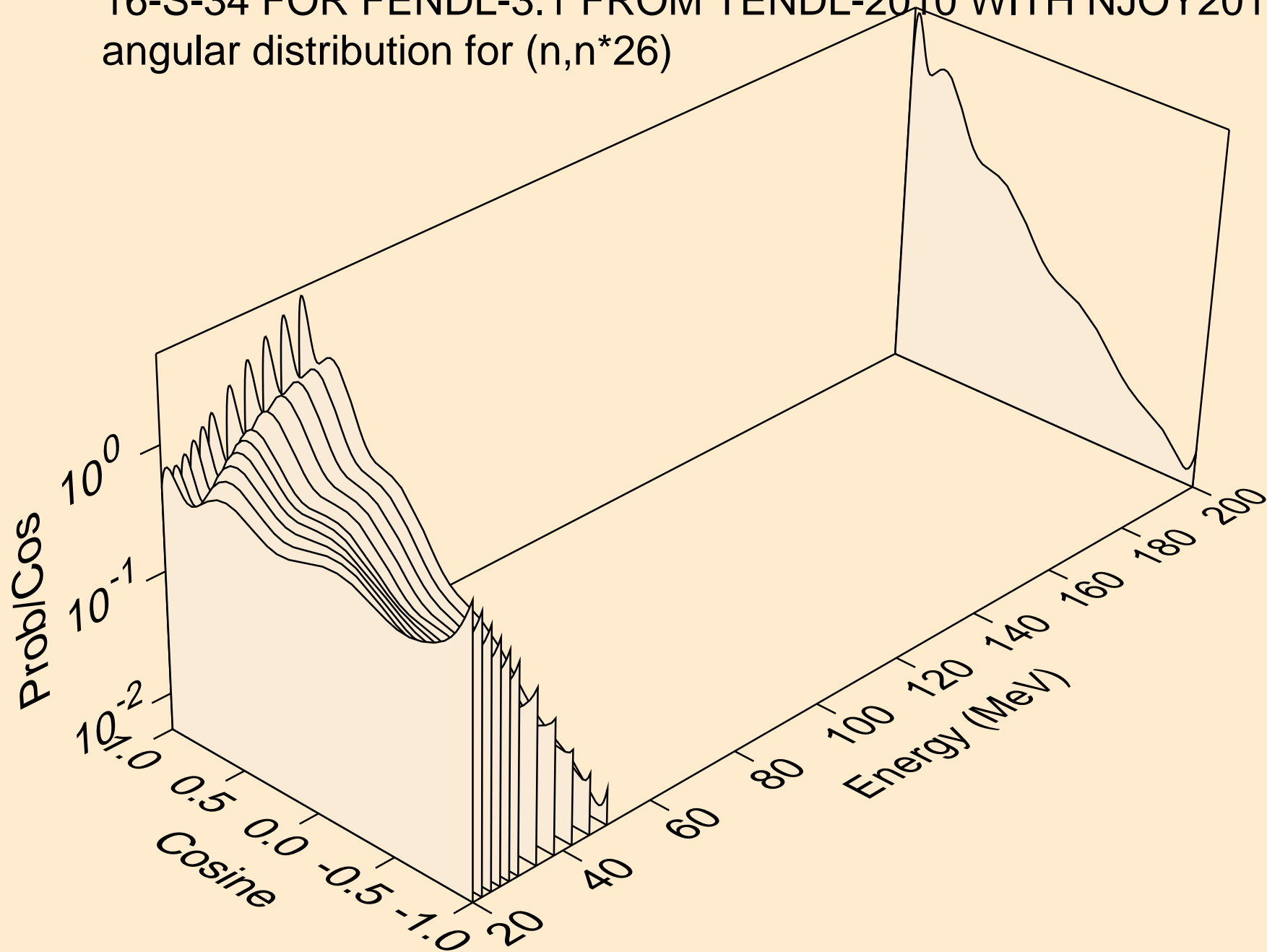

16-S-34 FOR FENDL-3.1 FROM TENDL-2010 WITH NJOY2012.50+
angular distribution for (n,n*27)

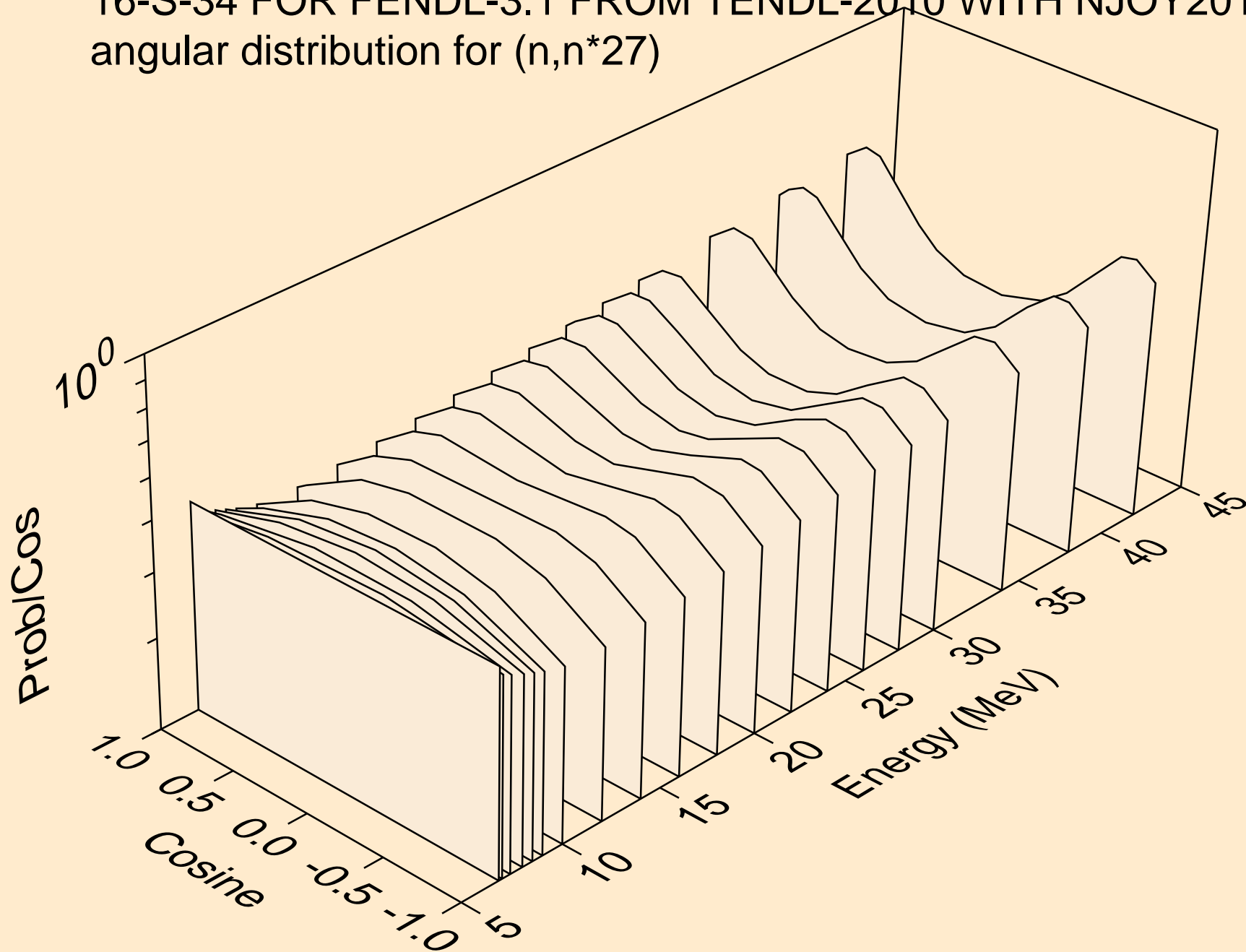

16-S-34 FOR FENDL-3.1 FROM TENDL-2010 WITH NJOY2012.50+
angular distribution for (n,n*28)

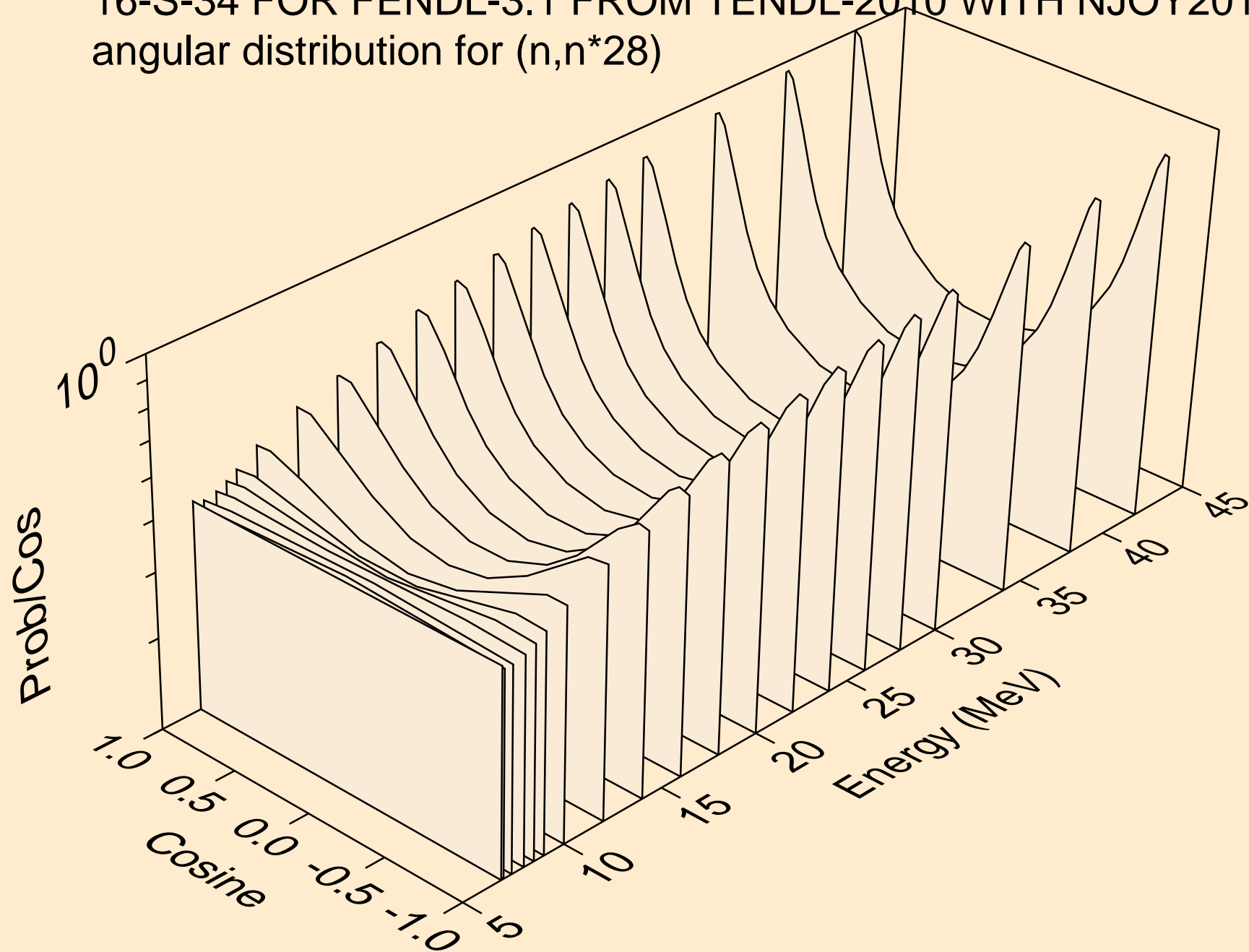

16-S-34 FOR FENDL-3.1 FROM TENDL-2010 WITH NJOY2012.50+
angular distribution for (n,n*29)

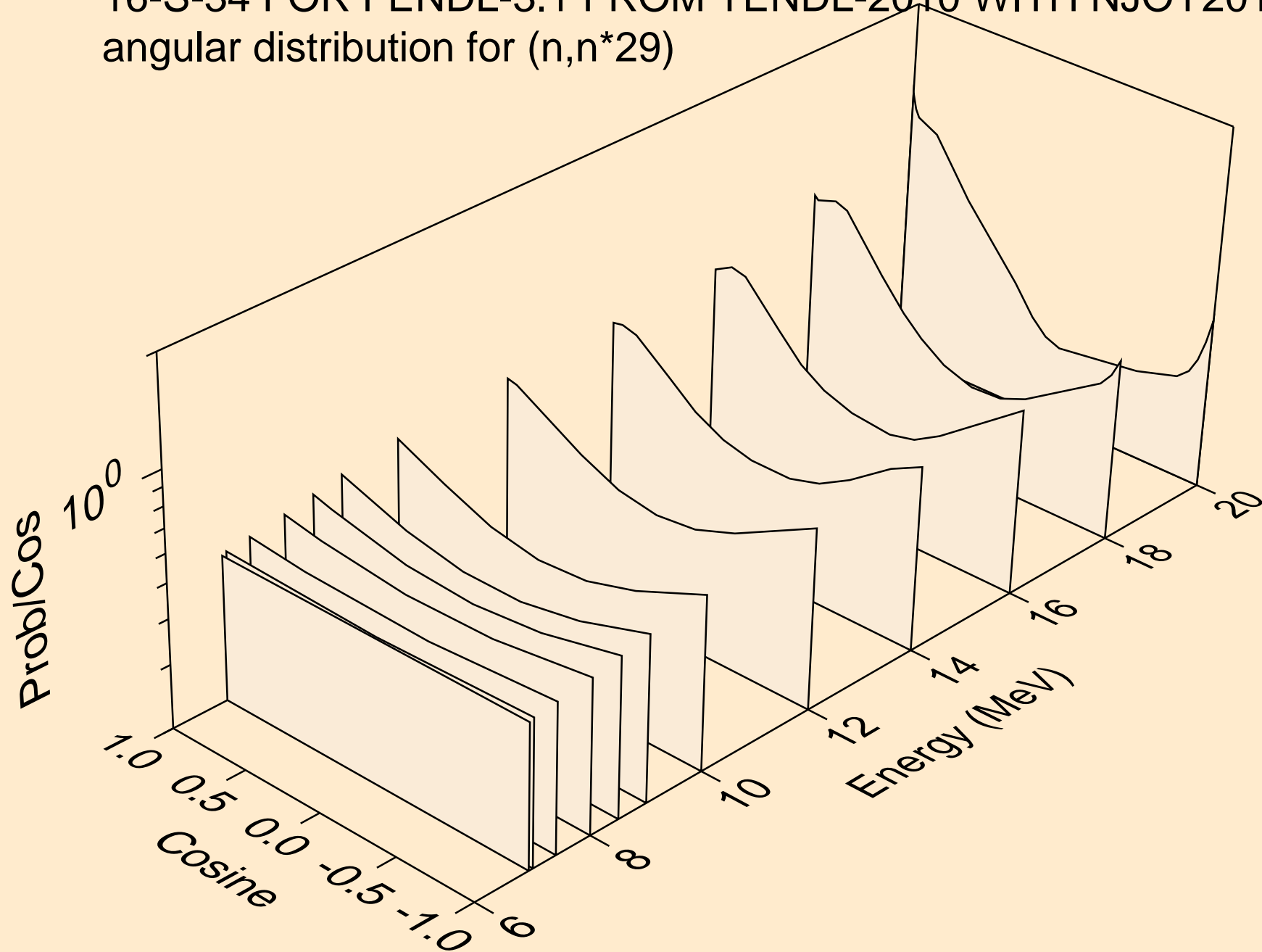

16-S-34 FOR FENDL-3.1 FROM TENDL-2010 WITH NJOY2012.50+
angular distribution for (n,n*29)

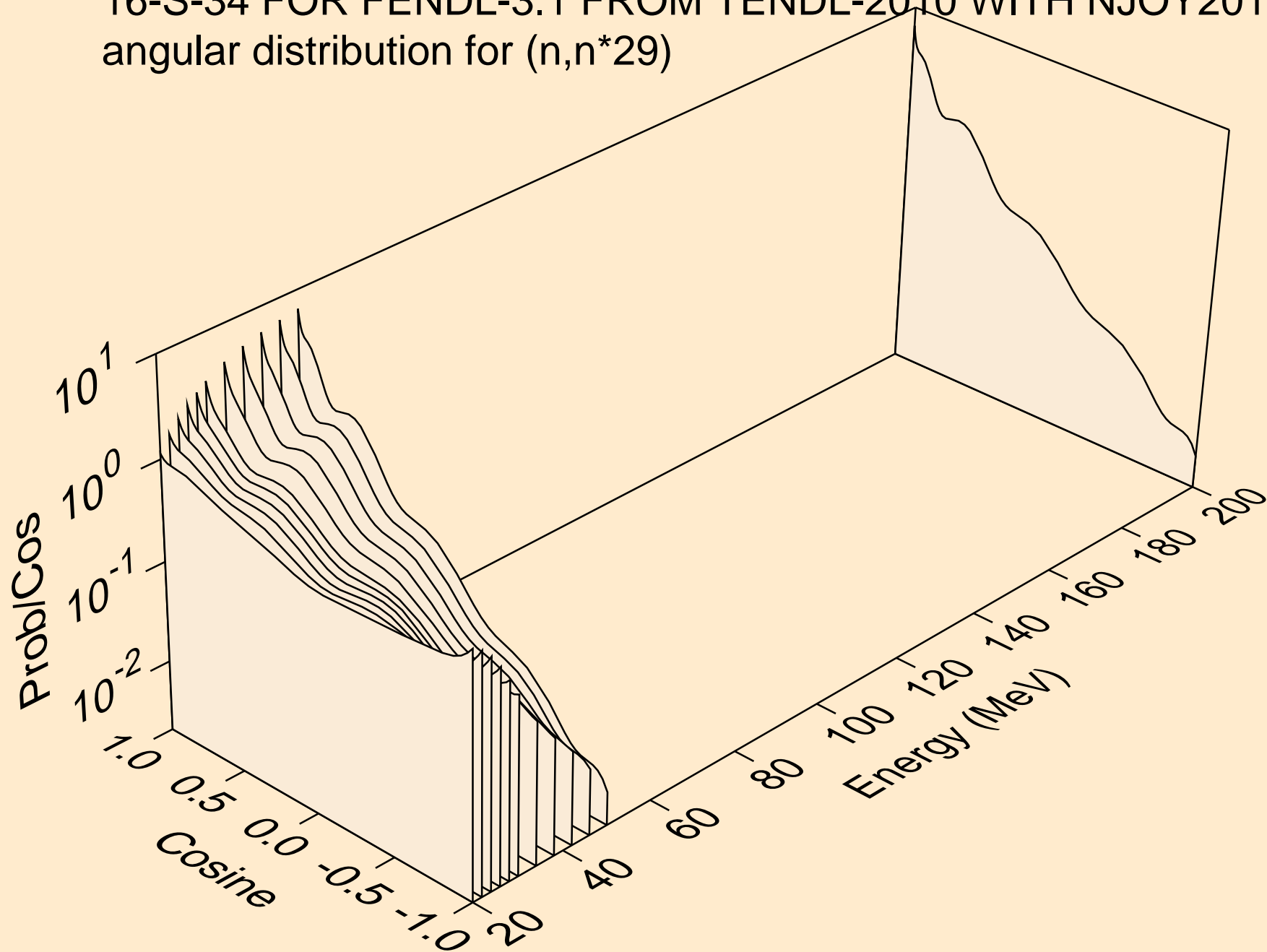

16-S-34 FOR FENDL-3.1 FROM TENDL-2010 WITH NJOY2012.50+
angular distribution for (n,n*30)

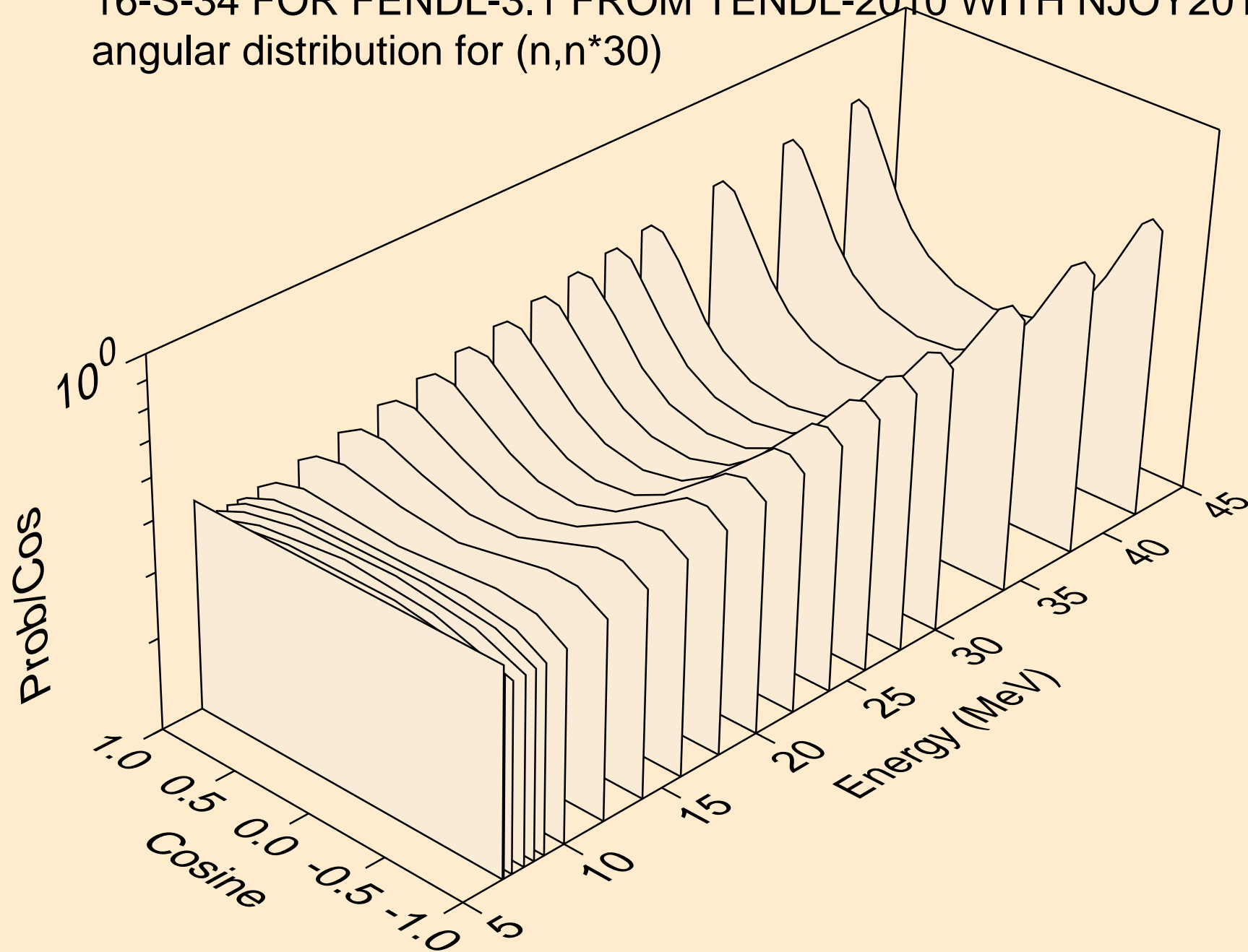

16-S-34 FOR FENDL-3.1 FROM TENDL-2010 WITH NJOY2012.50+
Neutron emission for (n,x)

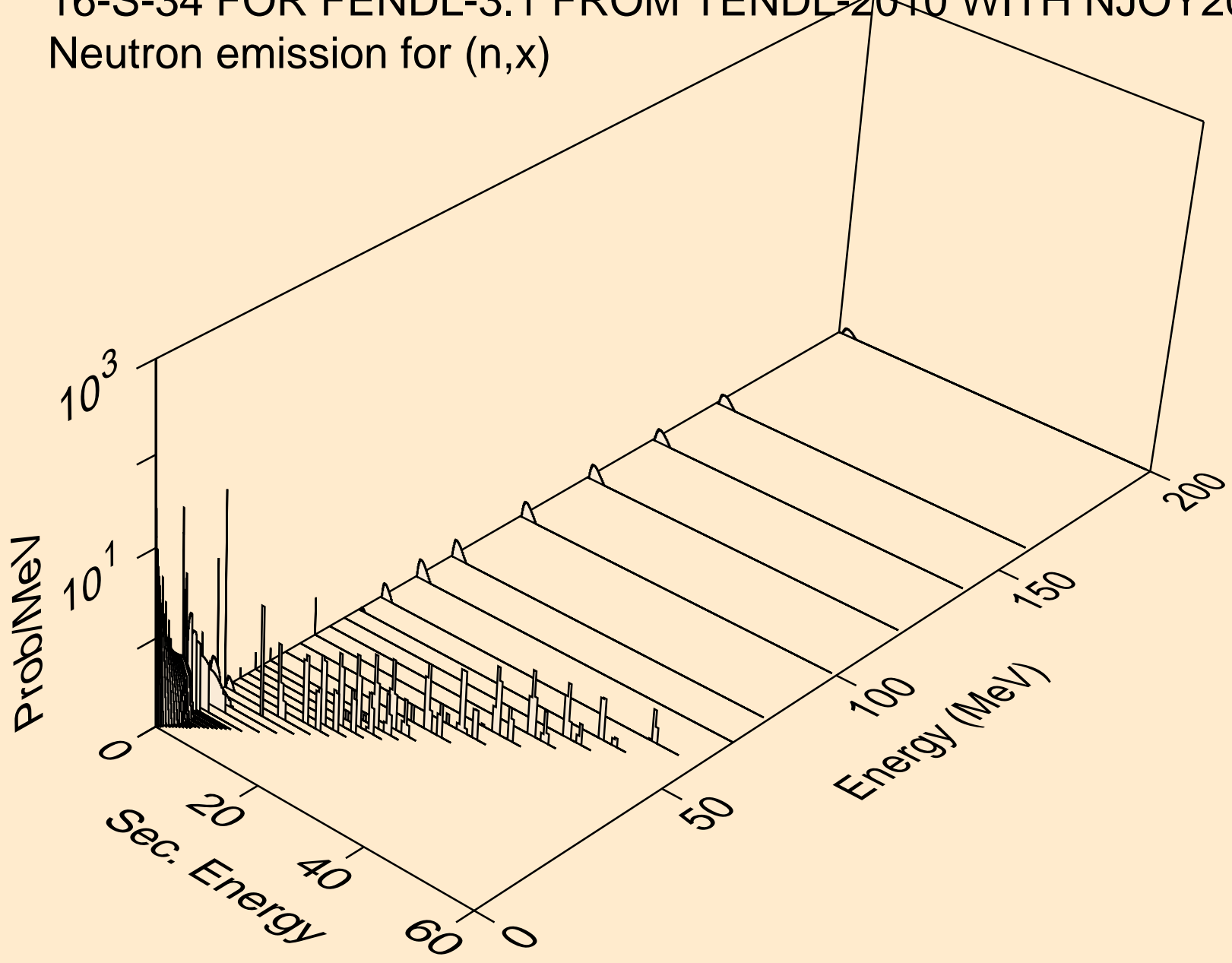

16-S-34 FOR FENDL-3.1 FROM TENDL-2010 WITH NJOY2012.50+
Neutron emission for (n,2nd)

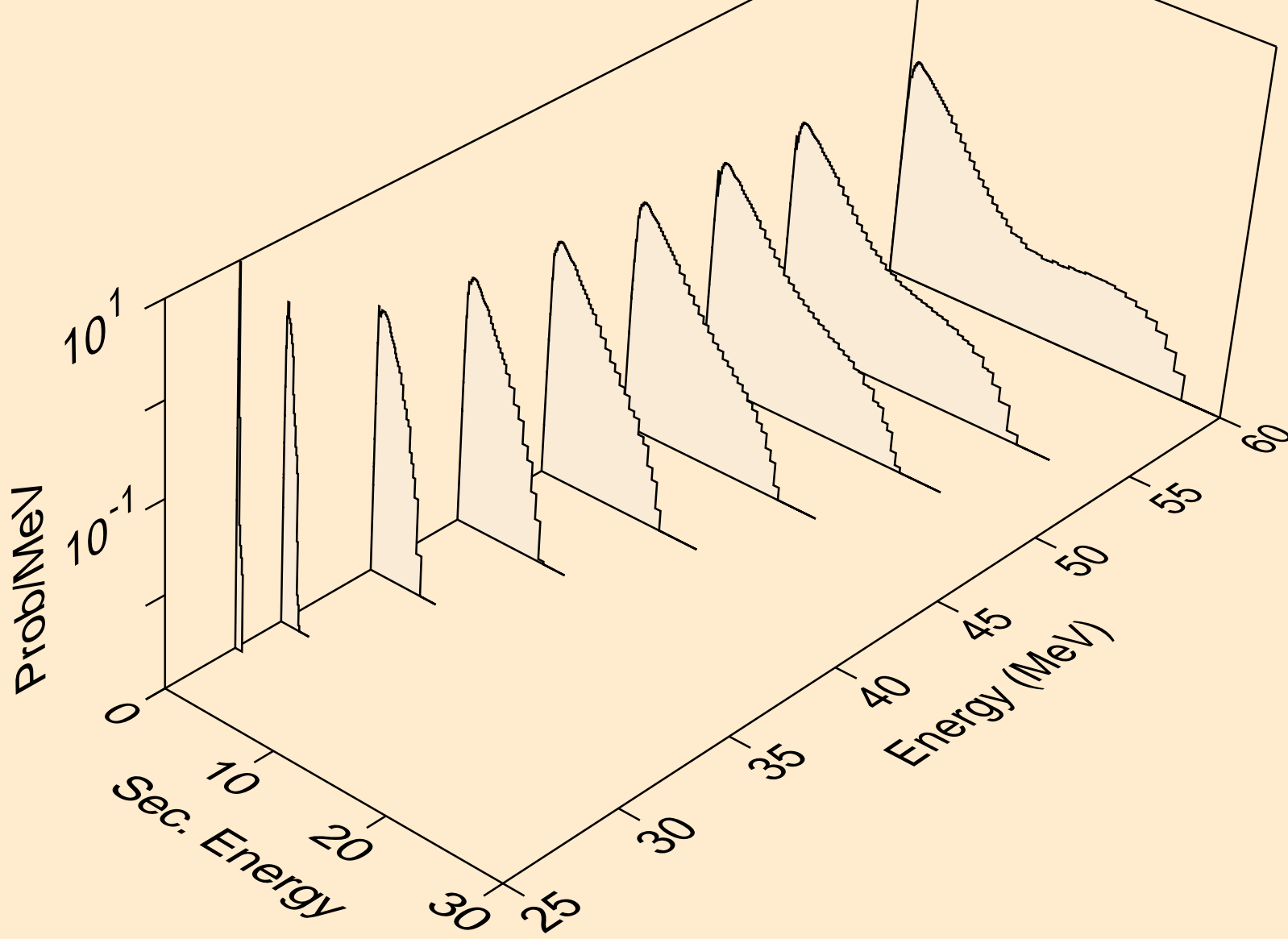

16-S-34 FOR FENDL-3.1 FROM TENDL-2010 WITH NJOY2012.50+
Neutron emission for (n,2n)

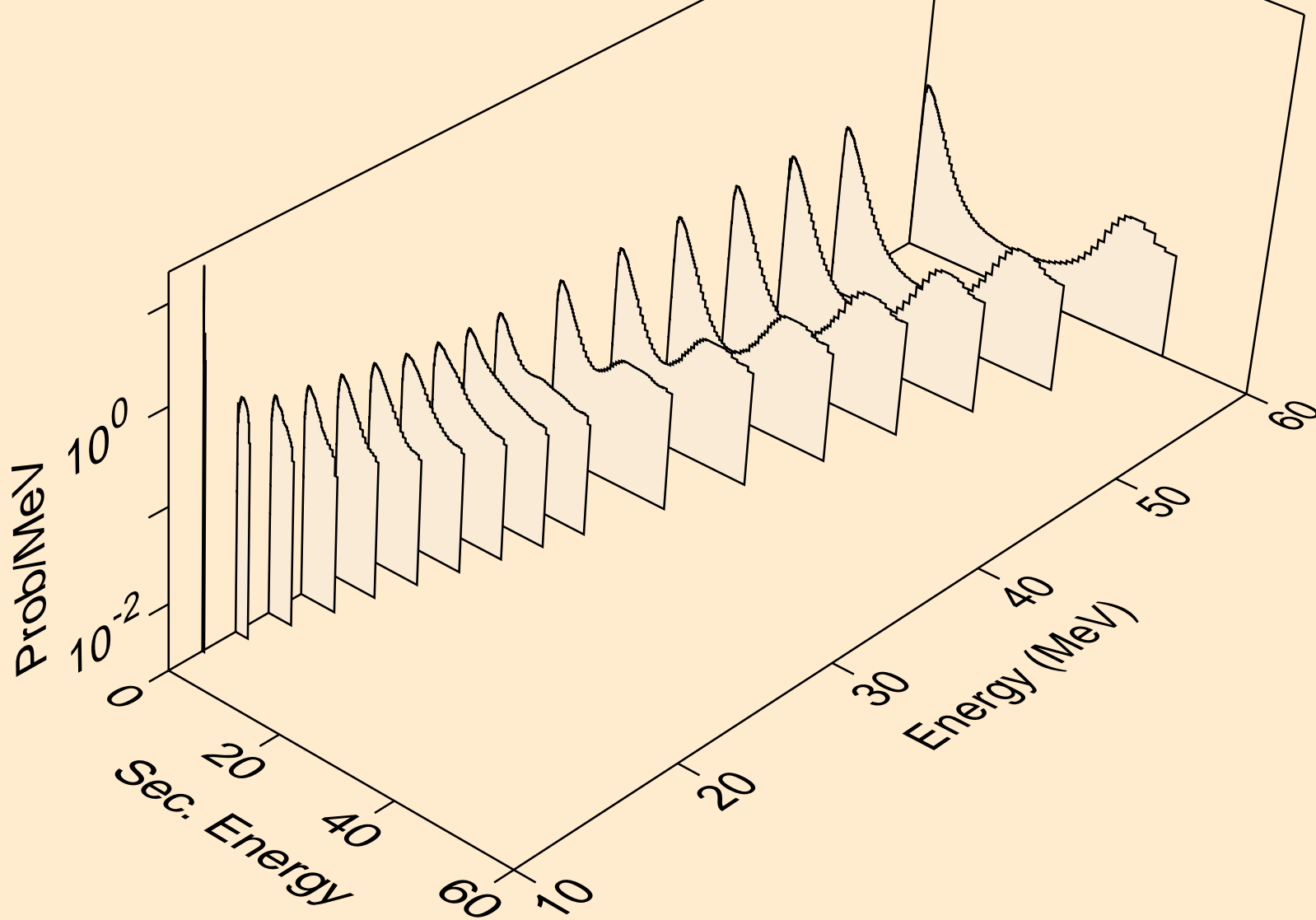

16-S-34 FOR FENDL-3.1 FROM TENDL-2010 WITH NJOY2012.50+
Neutron emission for (n,3n)

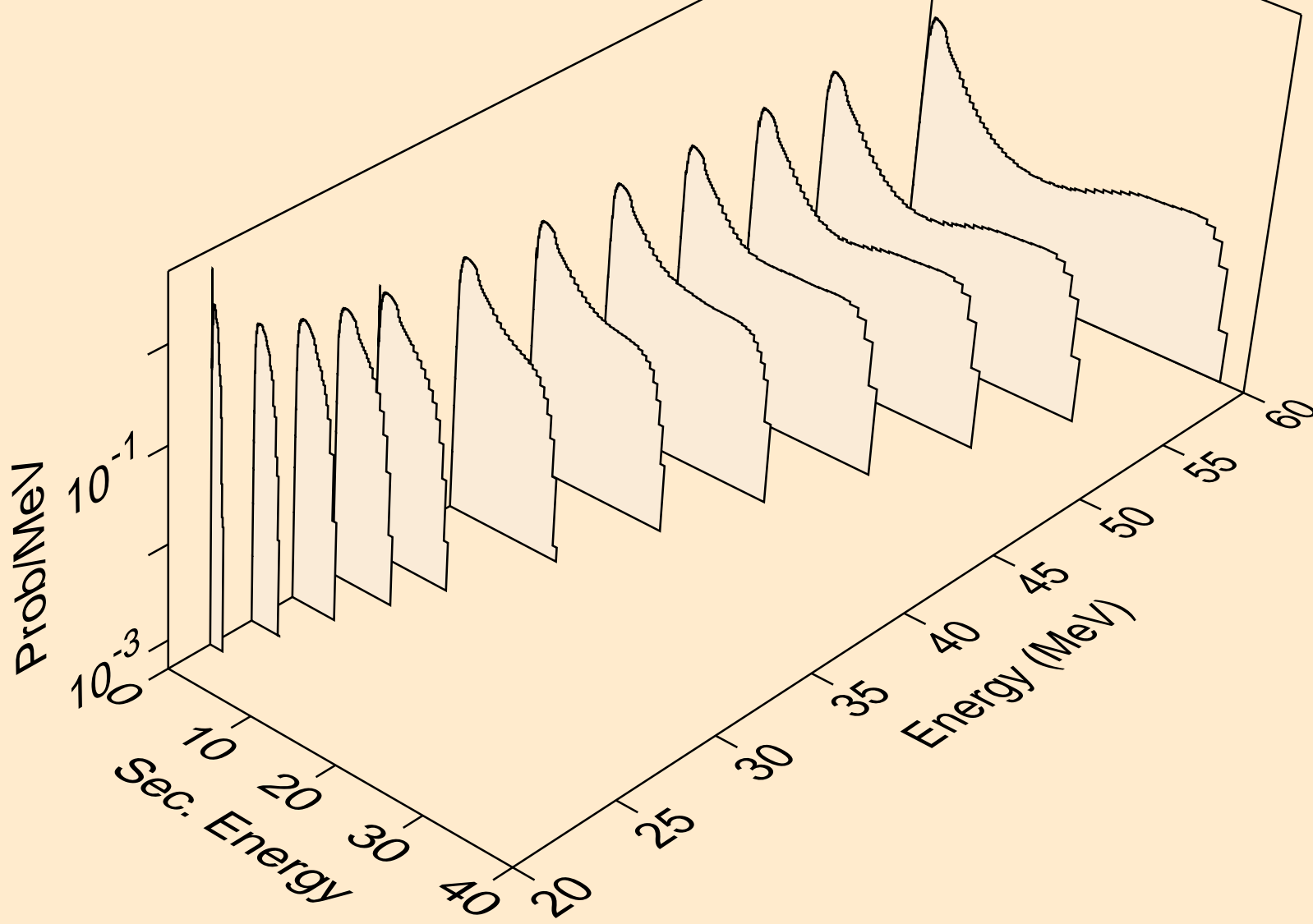

16-S-34 FOR FENDL-3.1 FROM TENDL-2010 WITH NJOY2012.50+
Neutron emission for (n,n*)a

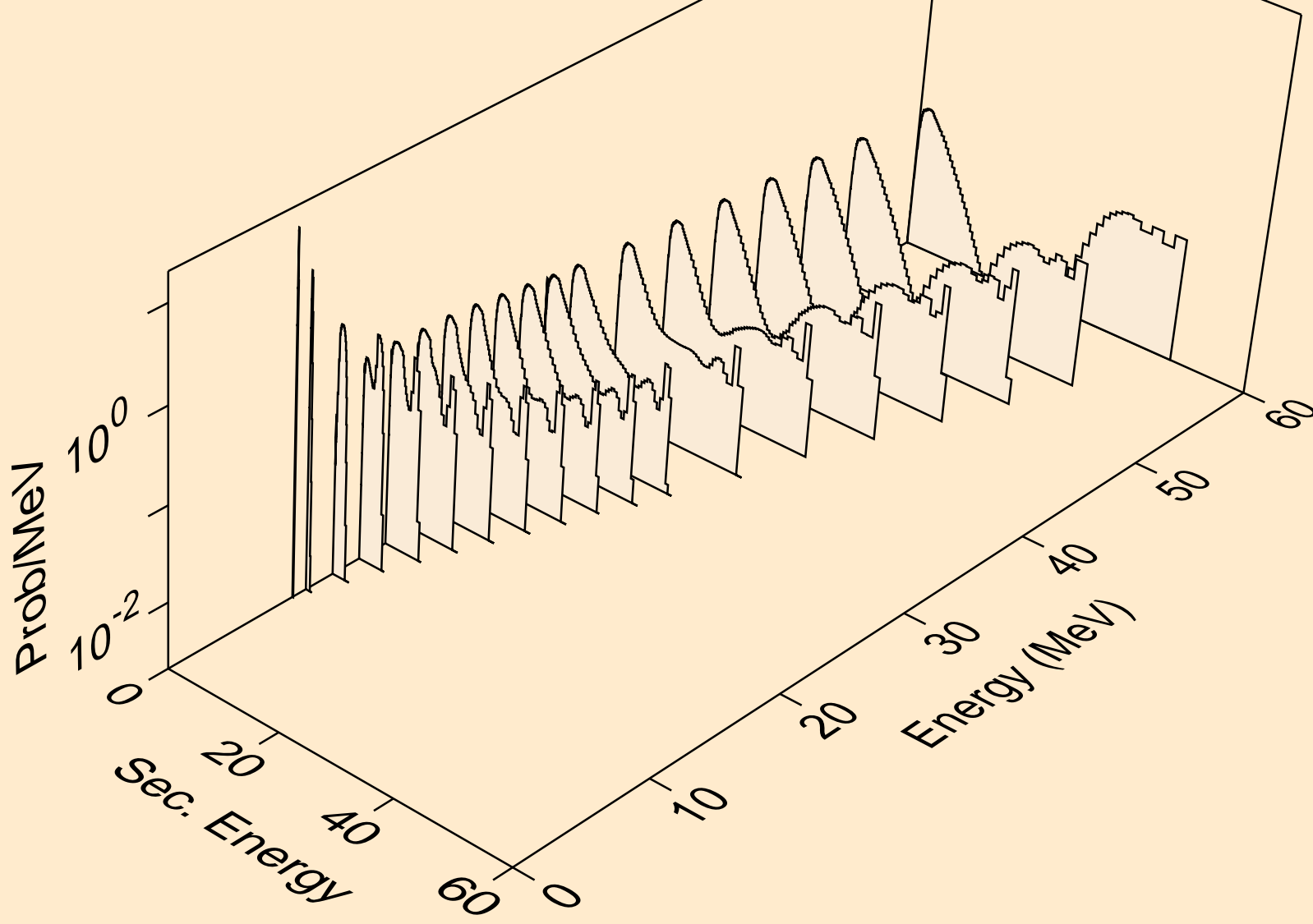

16-S-34 FOR FENDL-3.1 FROM TENDL-2010 WITH NJOY2012.50+
Neutron emission for (n,n*)3a

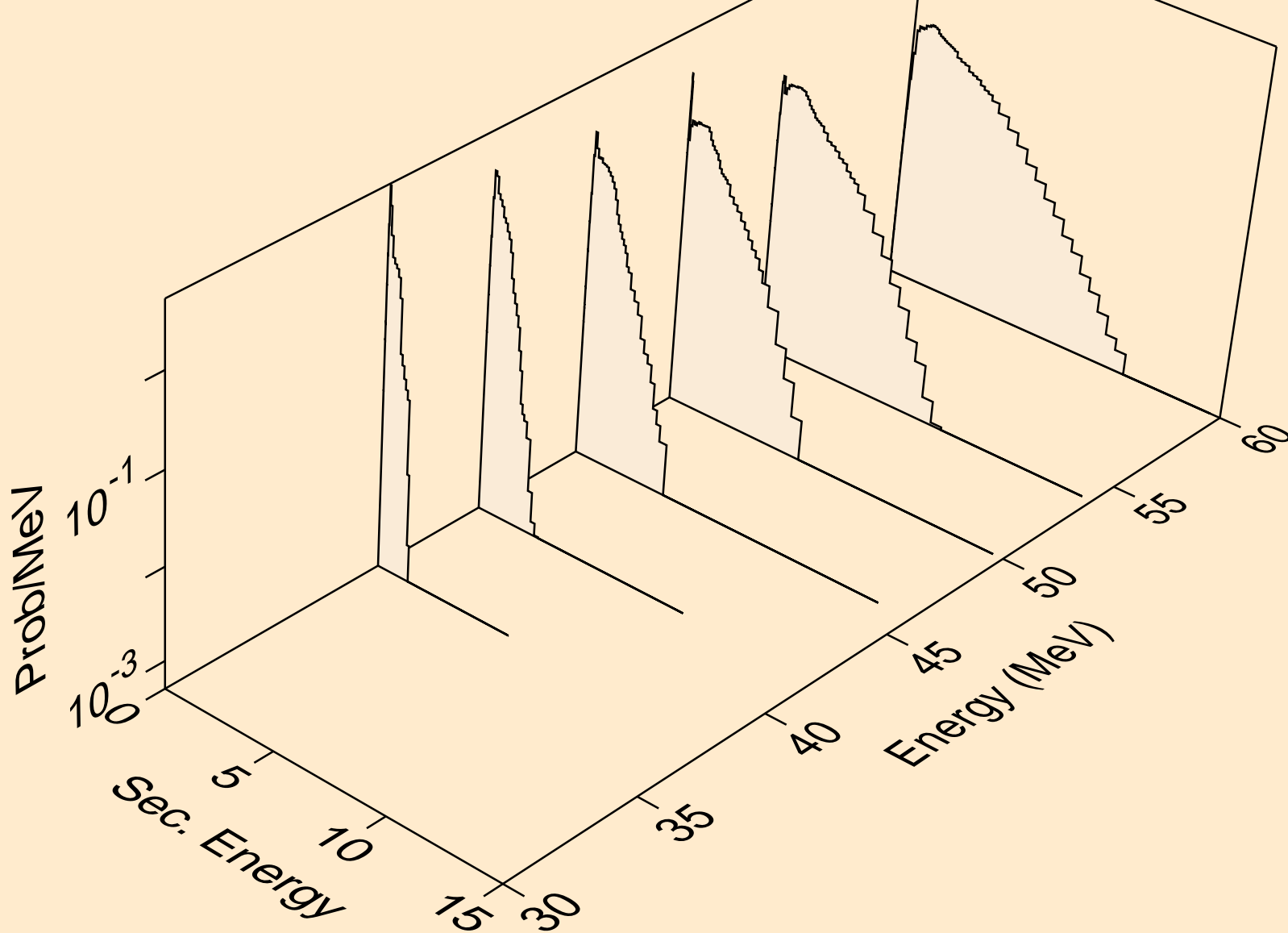

16-S-34 FOR FENDL-3.1 FROM TENDL-2010 WITH NJOY2012.50+
Neutron emission for (n,2n)a

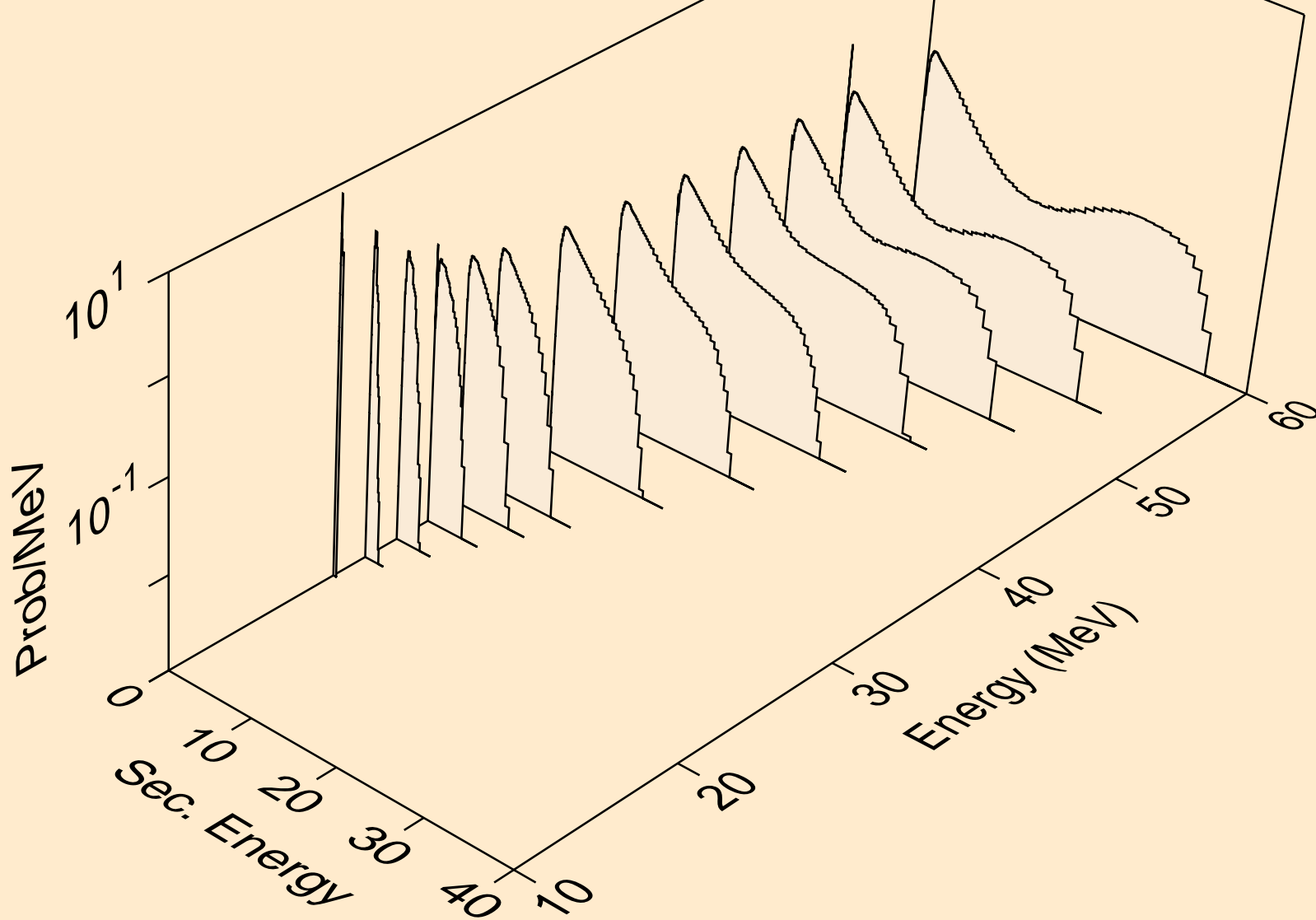

16-S-34 FOR FENDL-3.1 FROM TENDL-2010 WITH NJOY2012.50+
Neutron emission for (n,3n)a

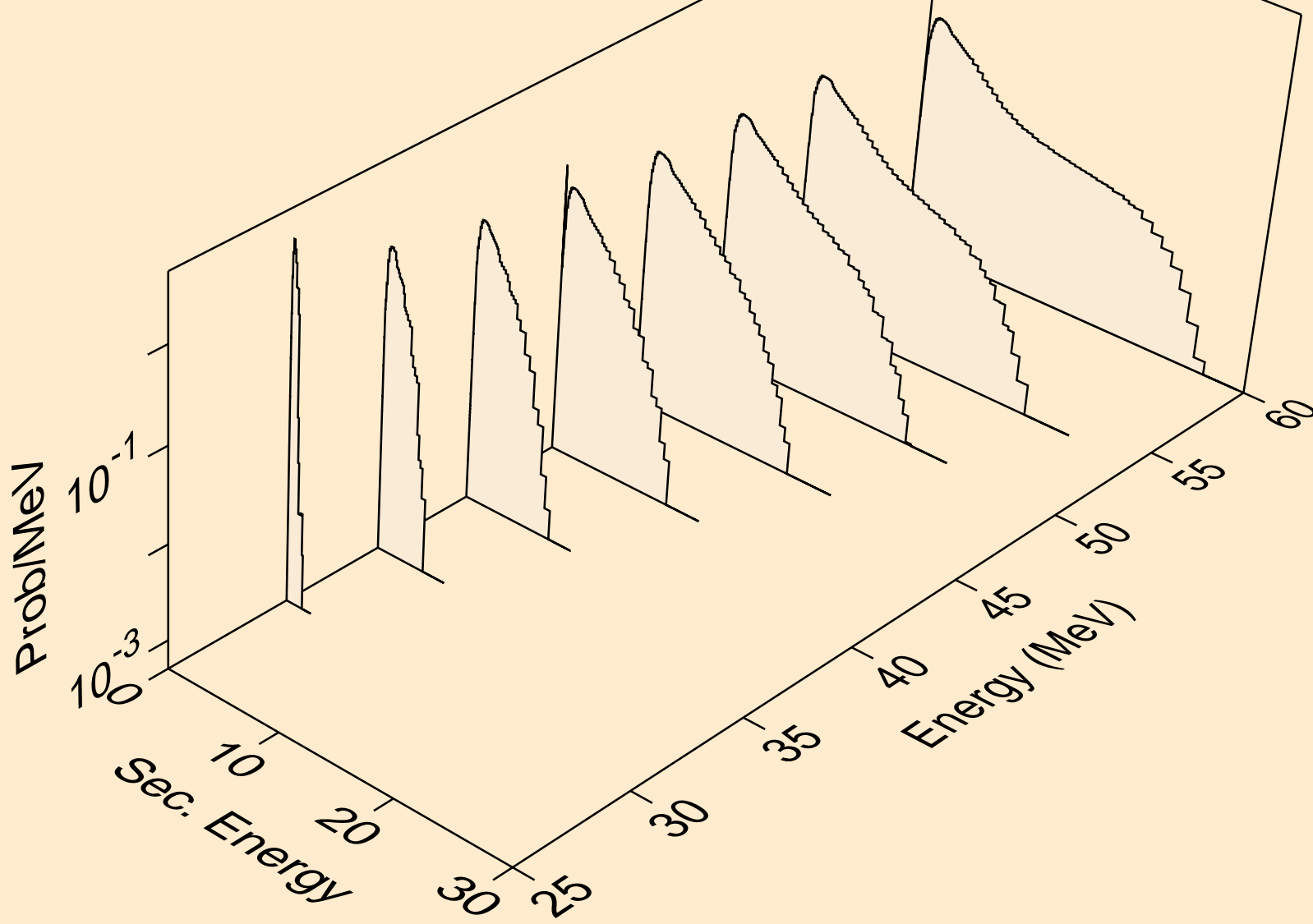

16-S-34 FOR FENDL-3.1 FROM TENDL-2010 WITH NJOY2012.50+
Neutron emission for (n,n*)p

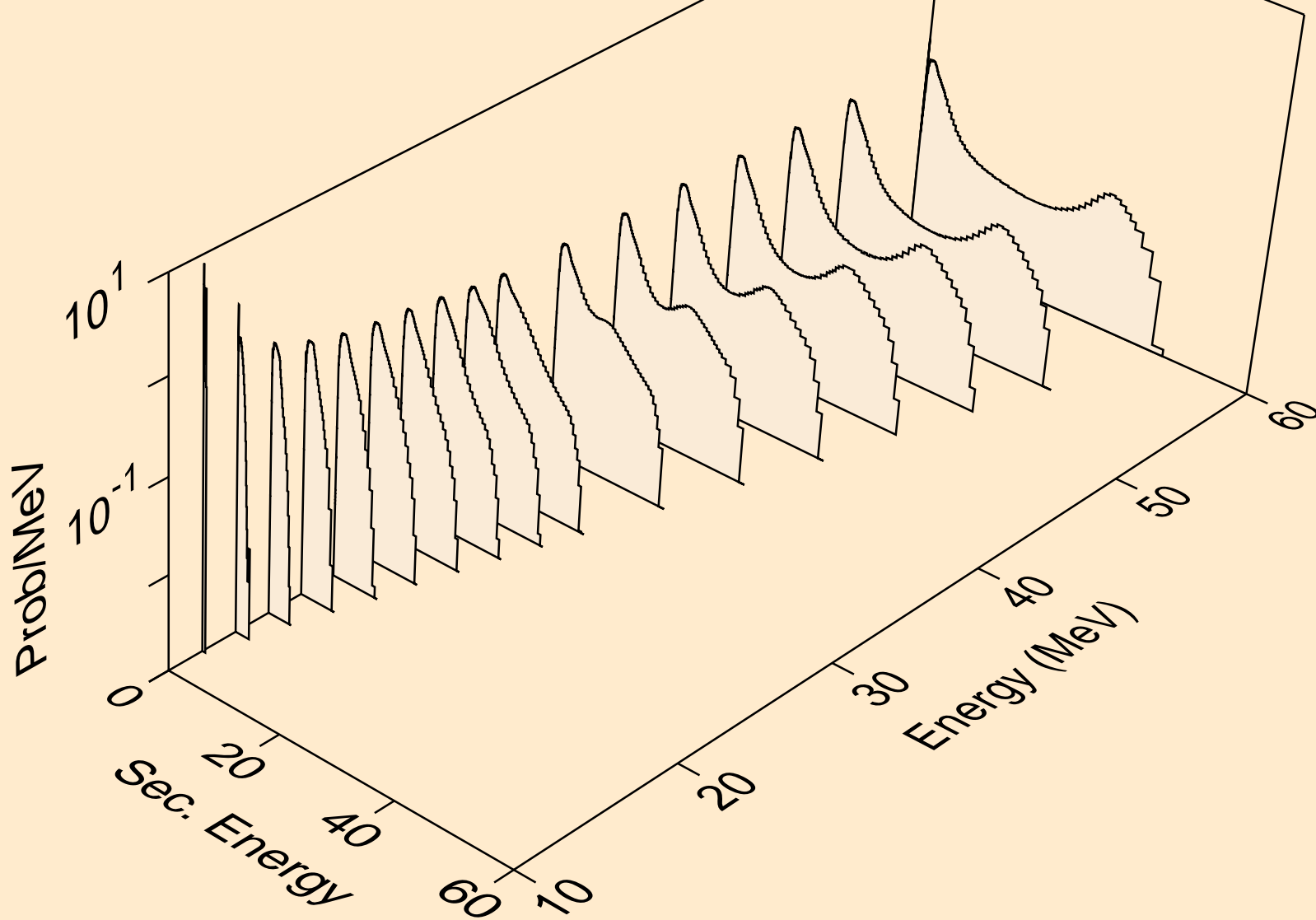

16-S-34 FOR FENDL-3.1 FROM TENDL-2010 WITH NJOY2012.50+
Neutron emission for (n,n*)2a

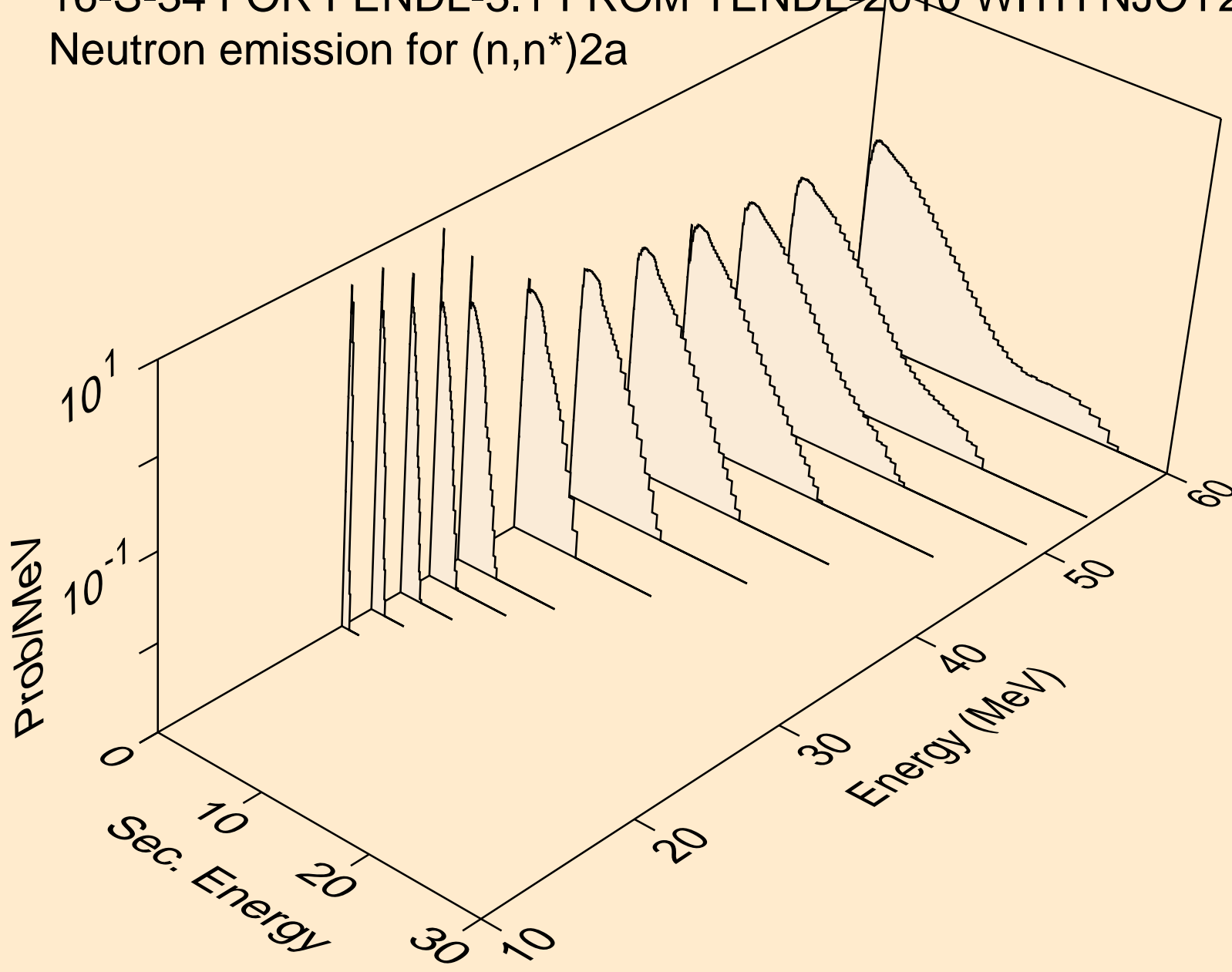

16-S-34 FOR FENDL-3.1 FROM TENDL-2010 WITH NJOY2012.50+
Neutron emission for (n,2n)2a

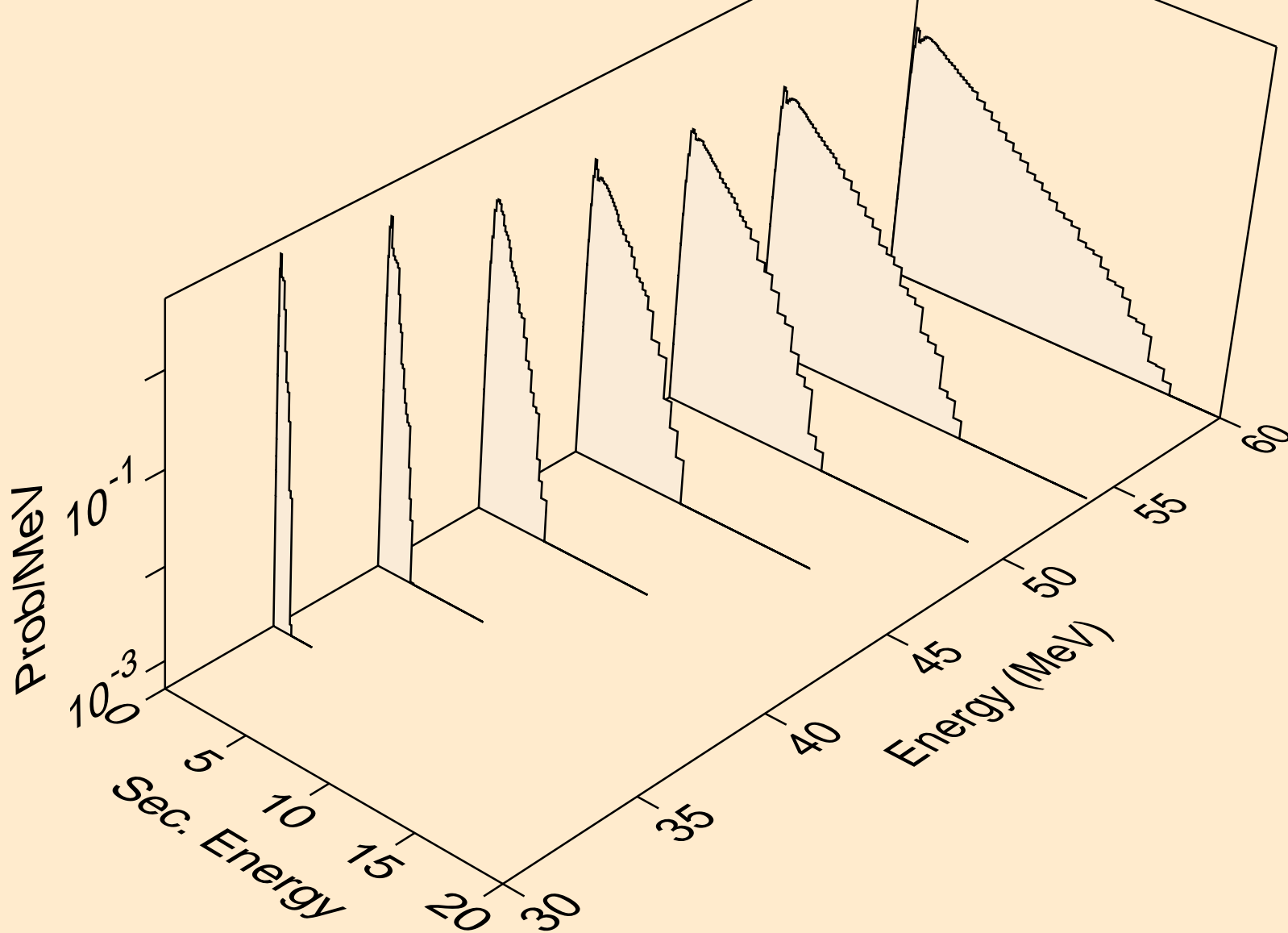

16-S-34 FOR FENDL-3.1 FROM TENDL-2010 WITH NJOY2012.50+
Neutron emission for (n,n*)d

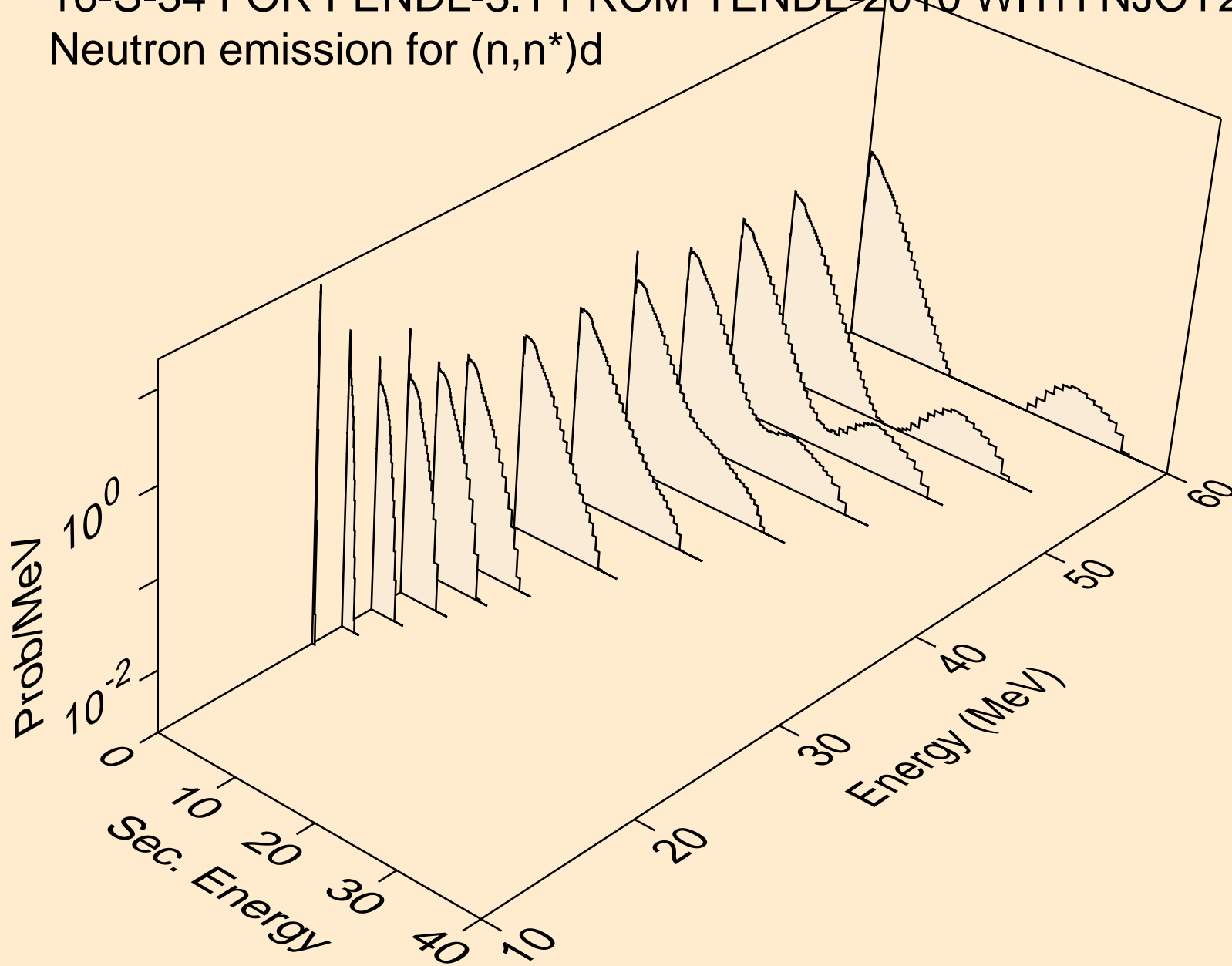

16-S-34 FOR FENDL-3.1 FROM TENDL-2010 WITH NJOY2012.50+
Neutron emission for (n,n*)t

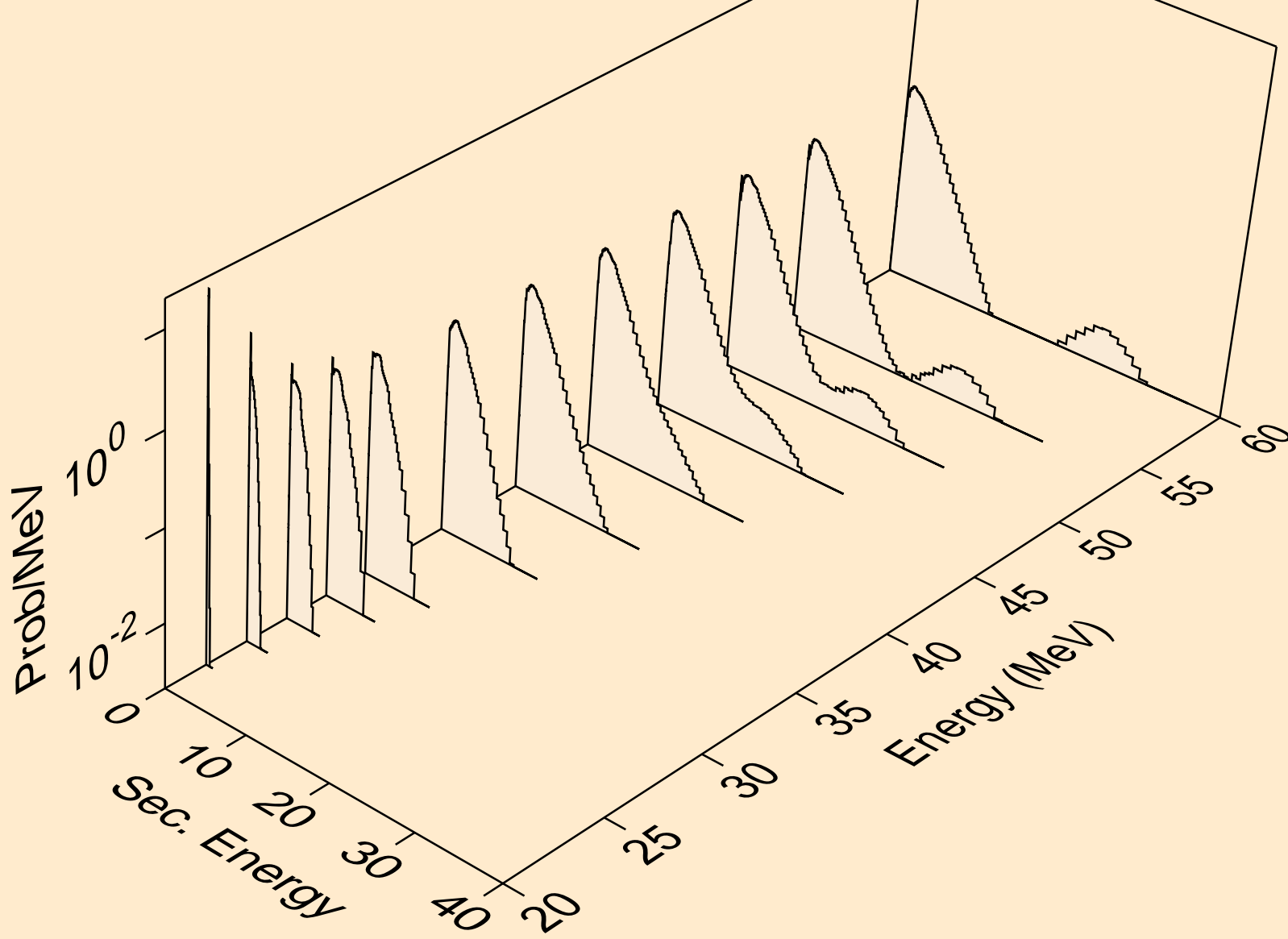

16-S-34 FOR FENDL-3.1 FROM TENDL-2010 WITH NJOY2012.50+
Neutron emission for (n,n*)he3

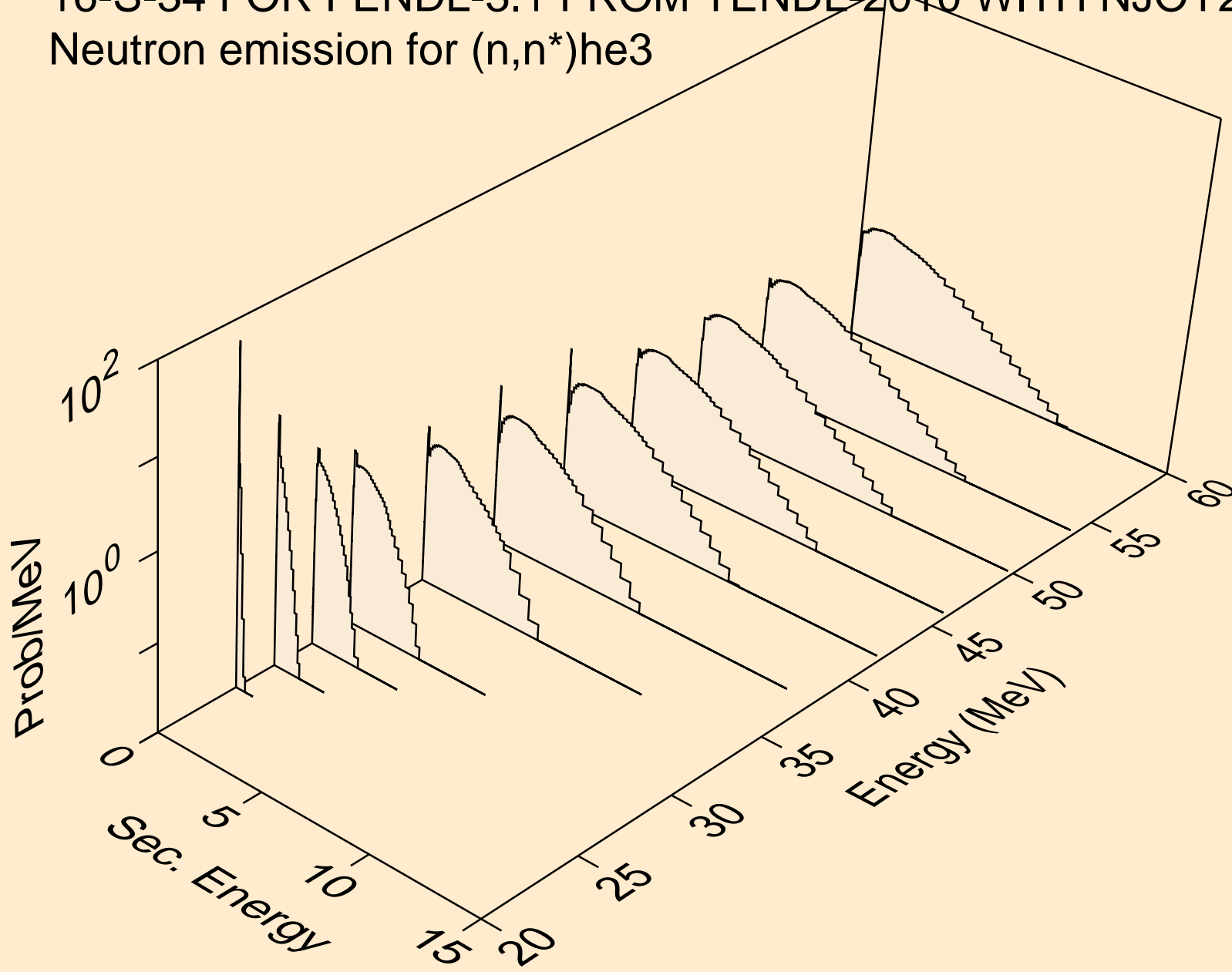

16-S-34 FOR FENDL-3.1 FROM TENDL-2010 WITH NJOY2012.50+
Neutron emission for (n,n*)d2a

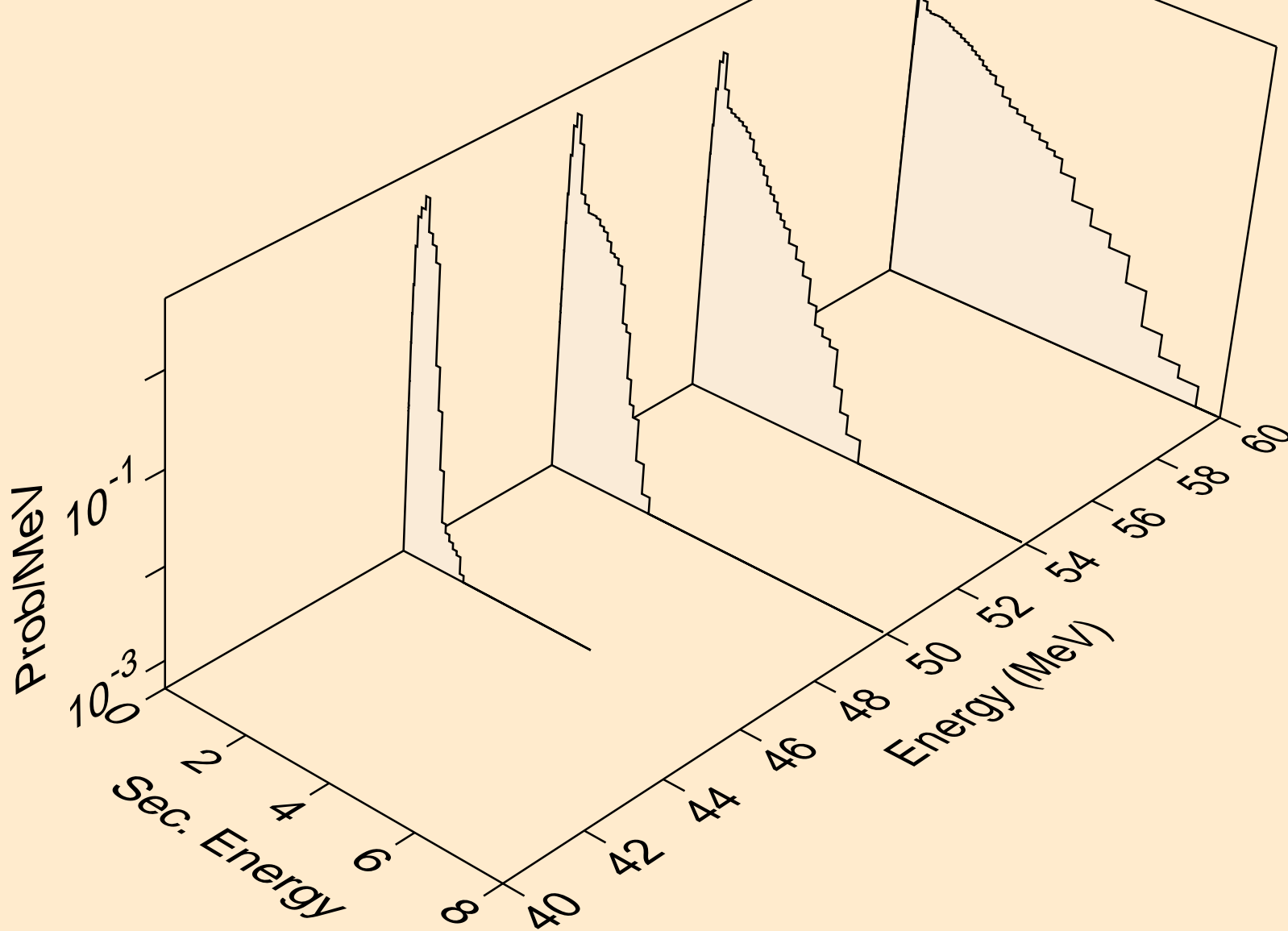

16-S-34 FOR FENDL-3.1 FROM TENDL-2010 WITH NJOY2012.50+
Neutron emission for (n,n*)t2a

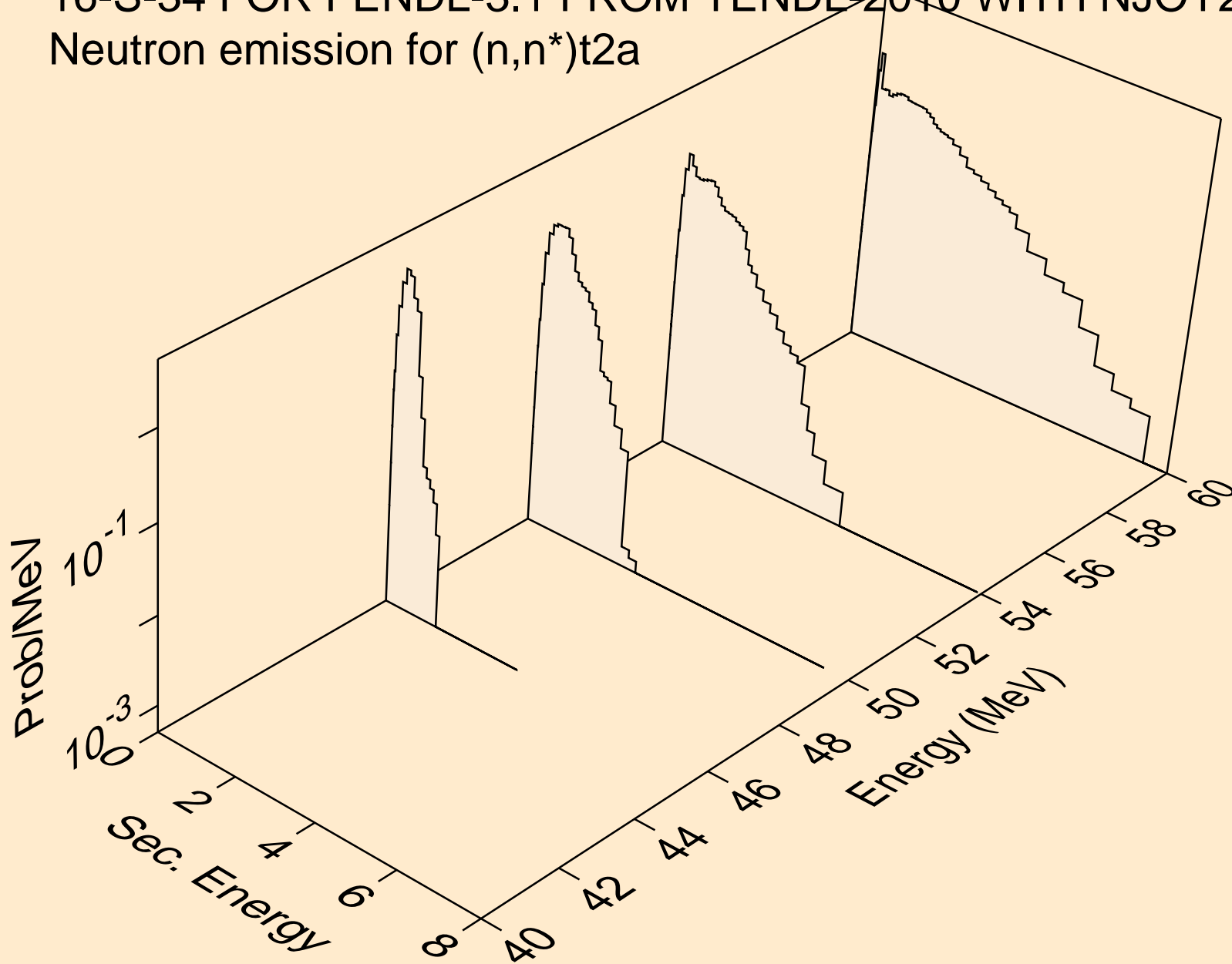

16-S-34 FOR FENDL-3.1 FROM TENDL-2010 WITH NJOY2012.50+
Neutron emission for (n,4n)

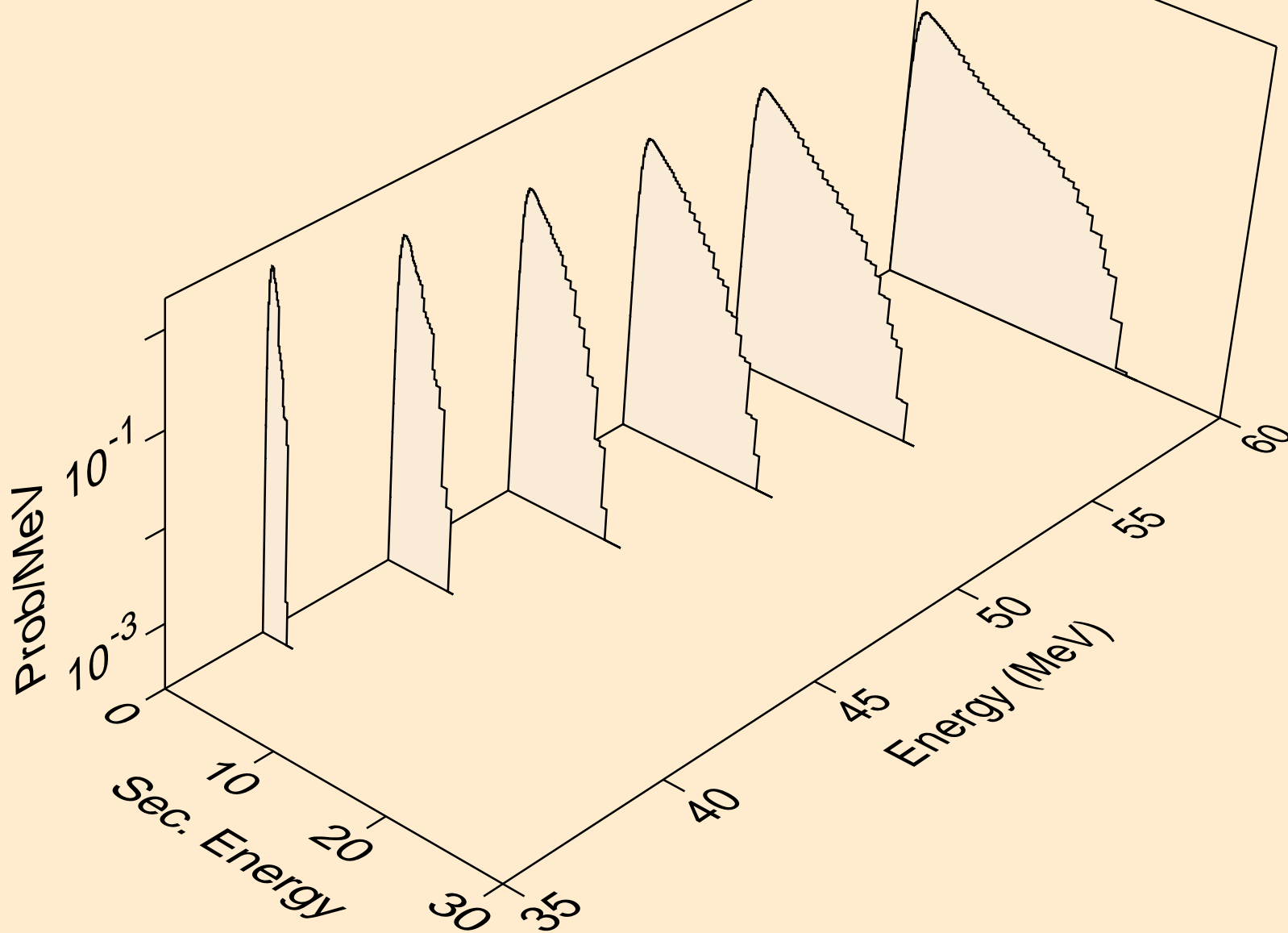

16-S-34 FOR FENDL-3.1 FROM TENDL-2010 WITH NJOY2012.50+
Neutron emission for (n,2np)

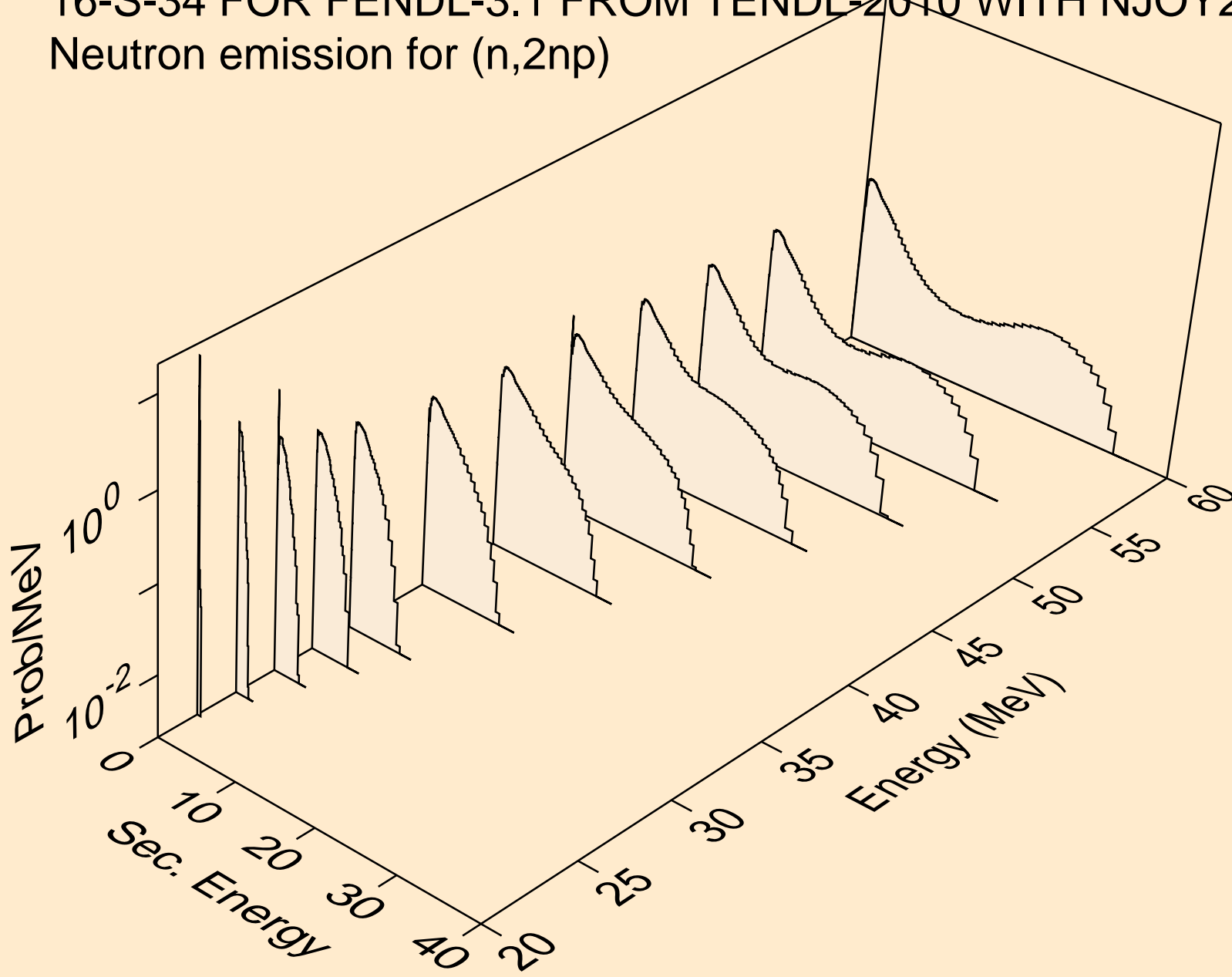

16-S-34 FOR FENDL-3.1 FROM TENDL-2010 WITH NJOY2012.50+
Neutron emission for (n,3np)

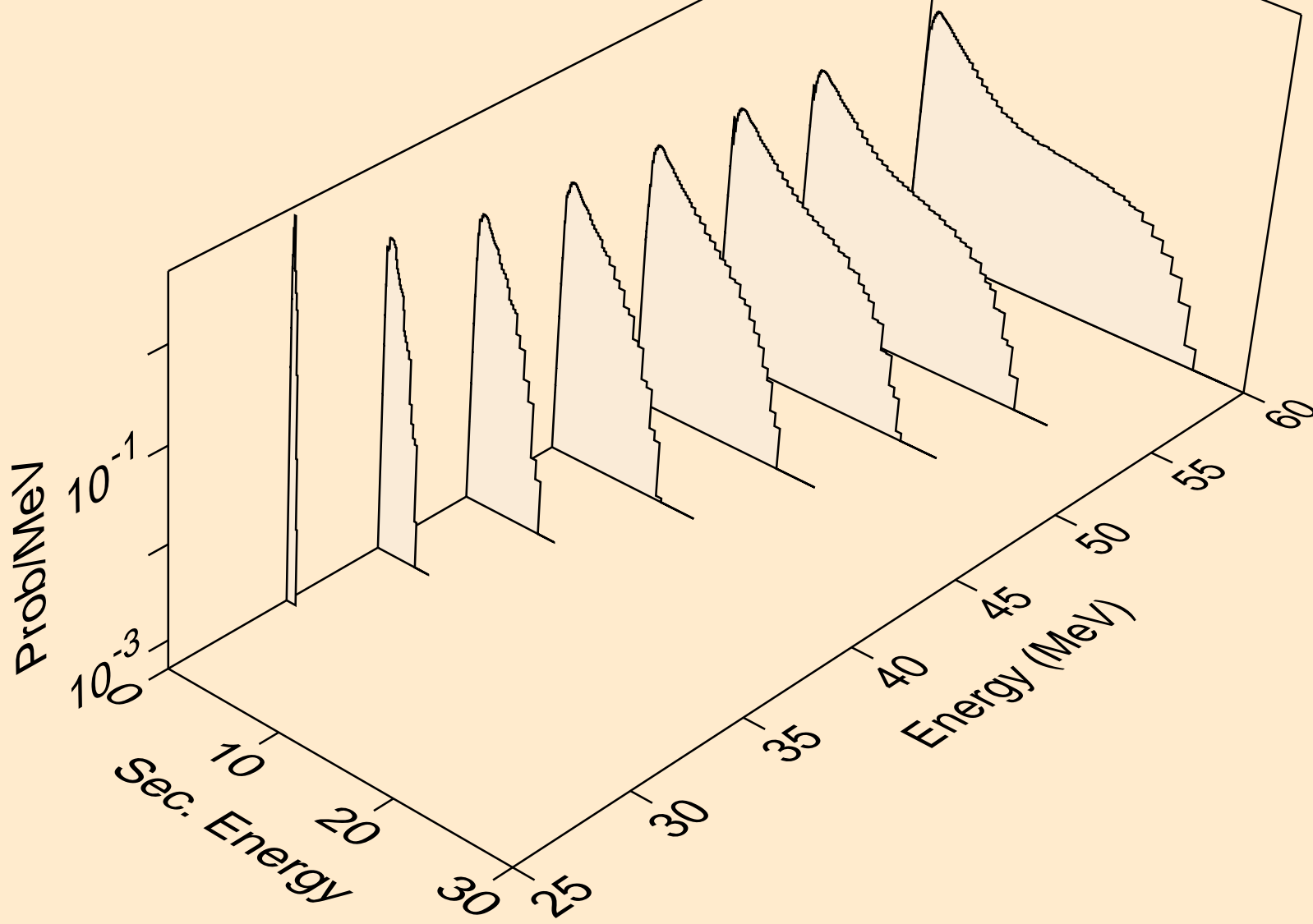

16-S-34 FOR FENDL-3.1 FROM TENDL-2010 WITH NJOY2012.50+
Neutron emission for (n,2np)

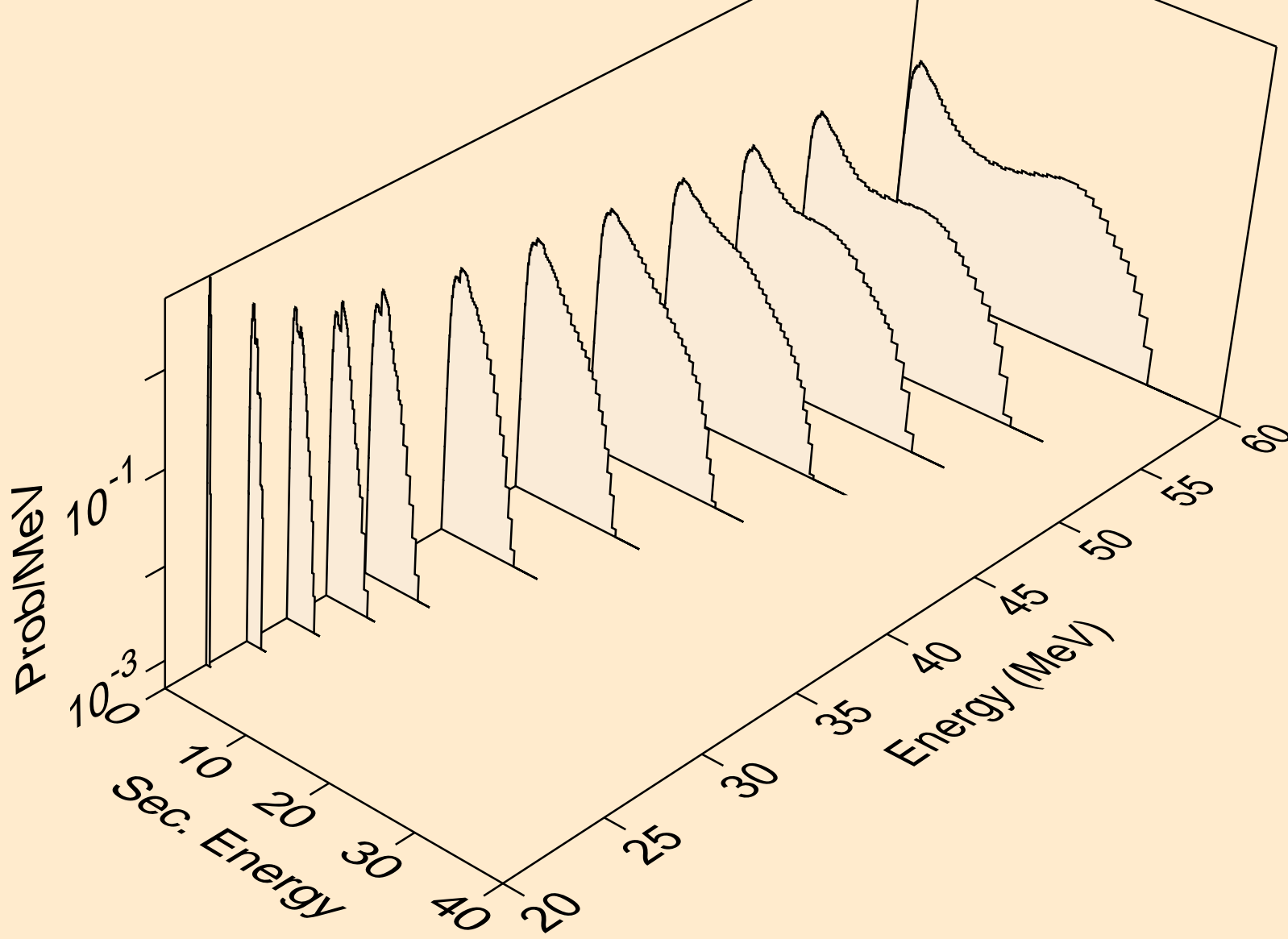

16-S-34 FOR FENDL-3.1 FROM TENDL-2010 WITH NJOY2012.50+
Neutron emission for (n,npa)

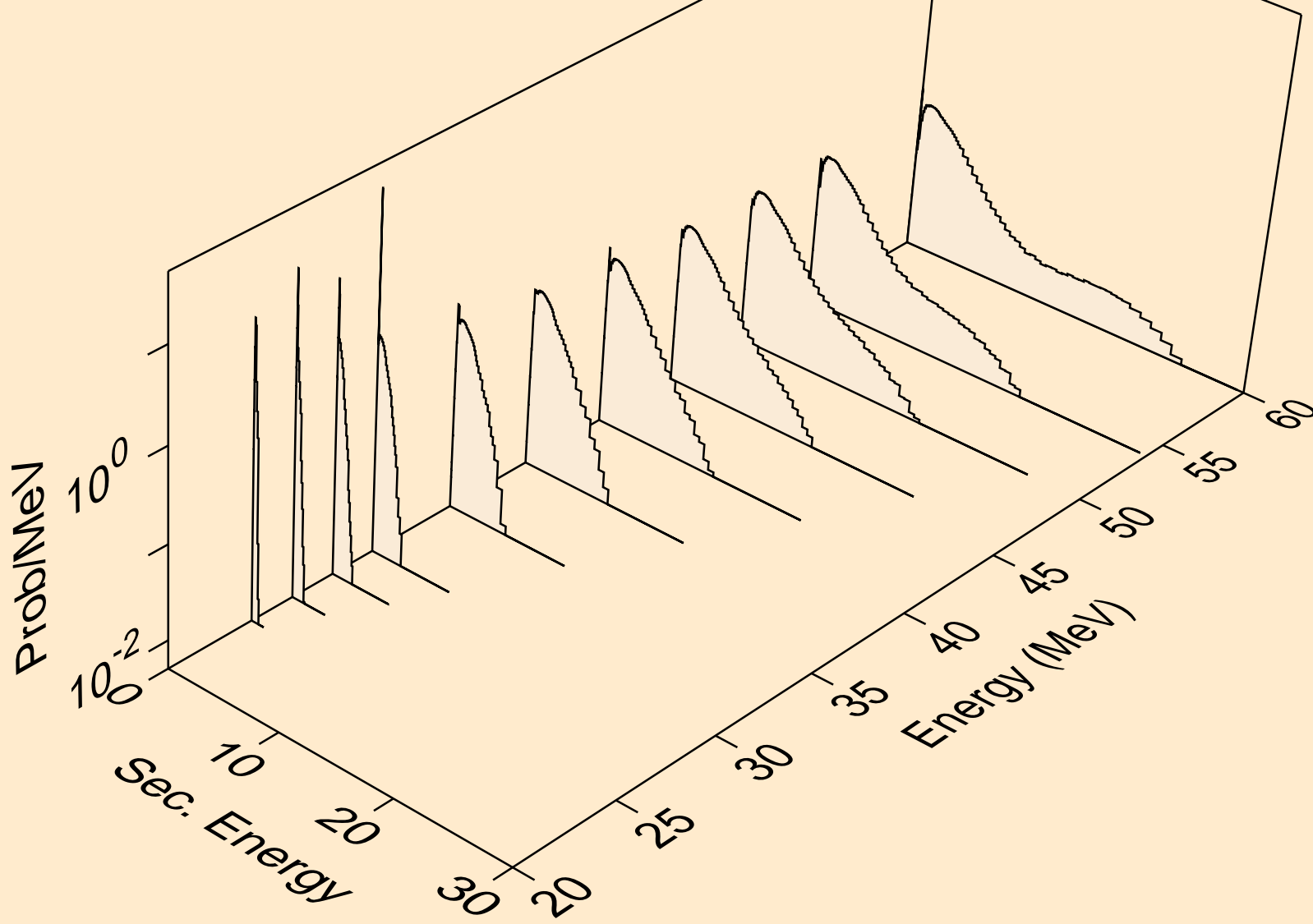

16-S-34 FOR FENDL-3.1 FROM TENDL-2010 WITH NJOY2012.50+
Neutron emission for (n,n*c)

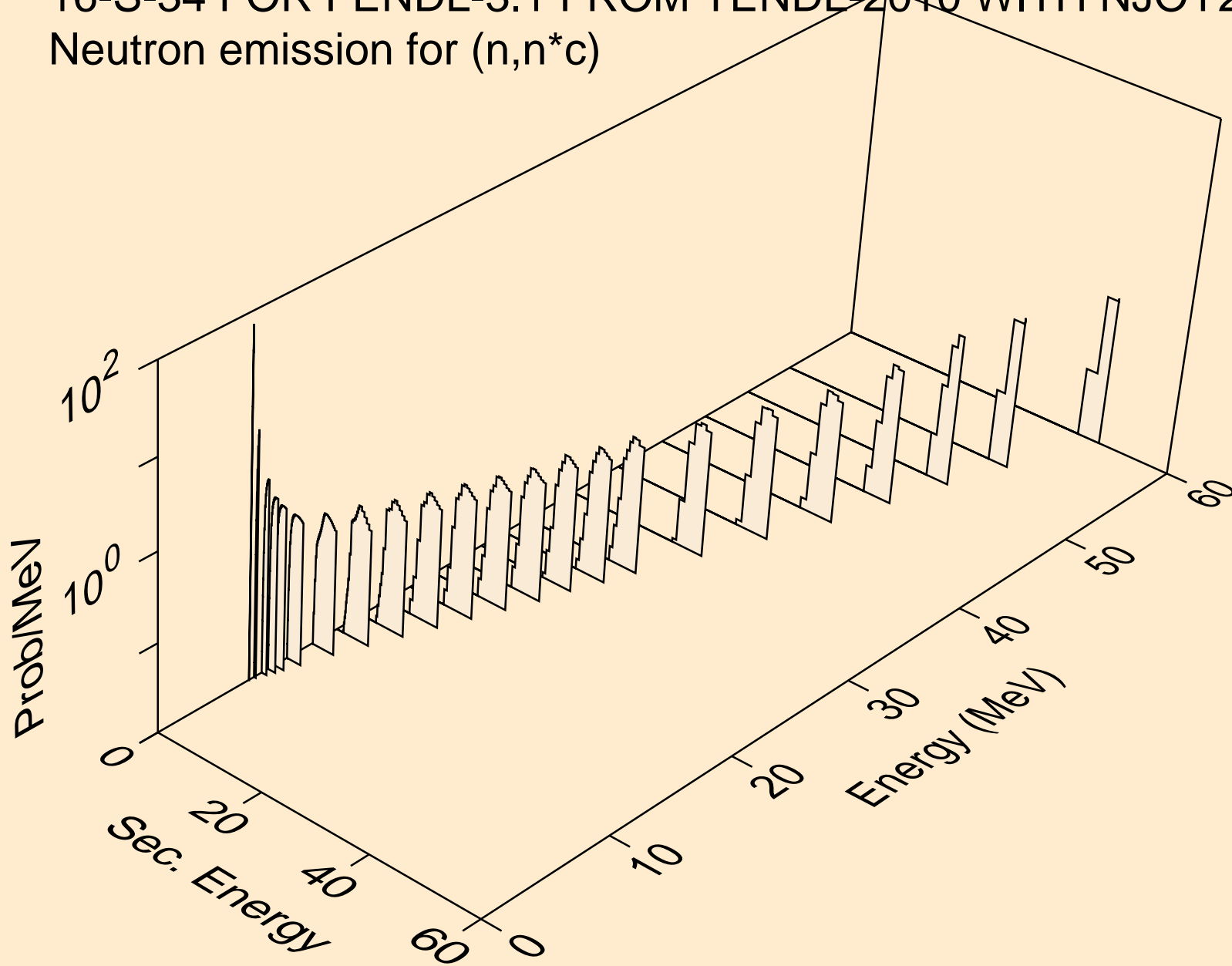

16-S-34 FOR FENDL-3.1 FROM TENDL-2010 WITH NJOY2012.50+
Neutron emission for (n,5n)

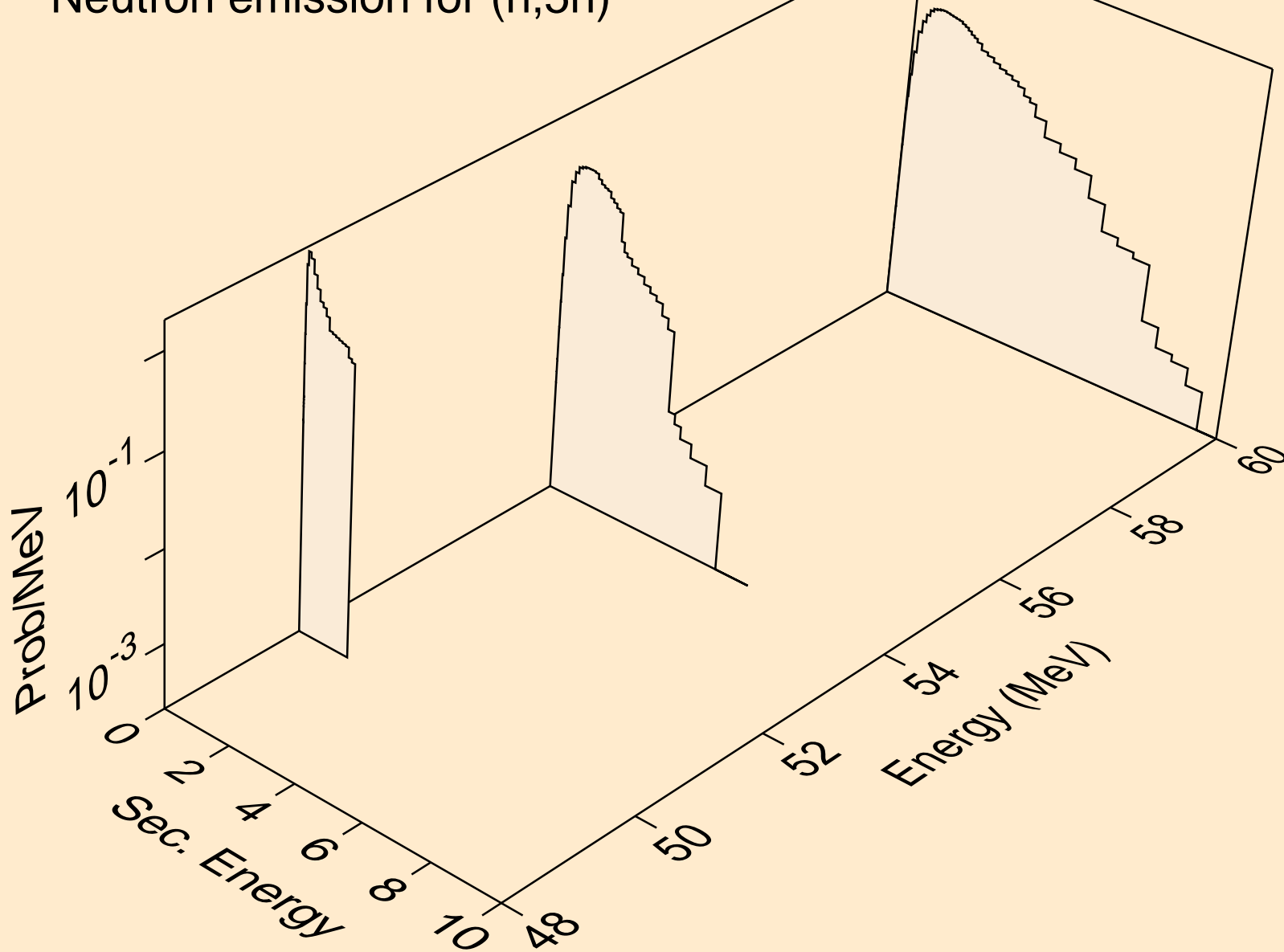

16-S-34 FOR FENDL-3.1 FROM TENDL-2010 WITH NJOY2012.50+
Neutron emission for (n,2nt)

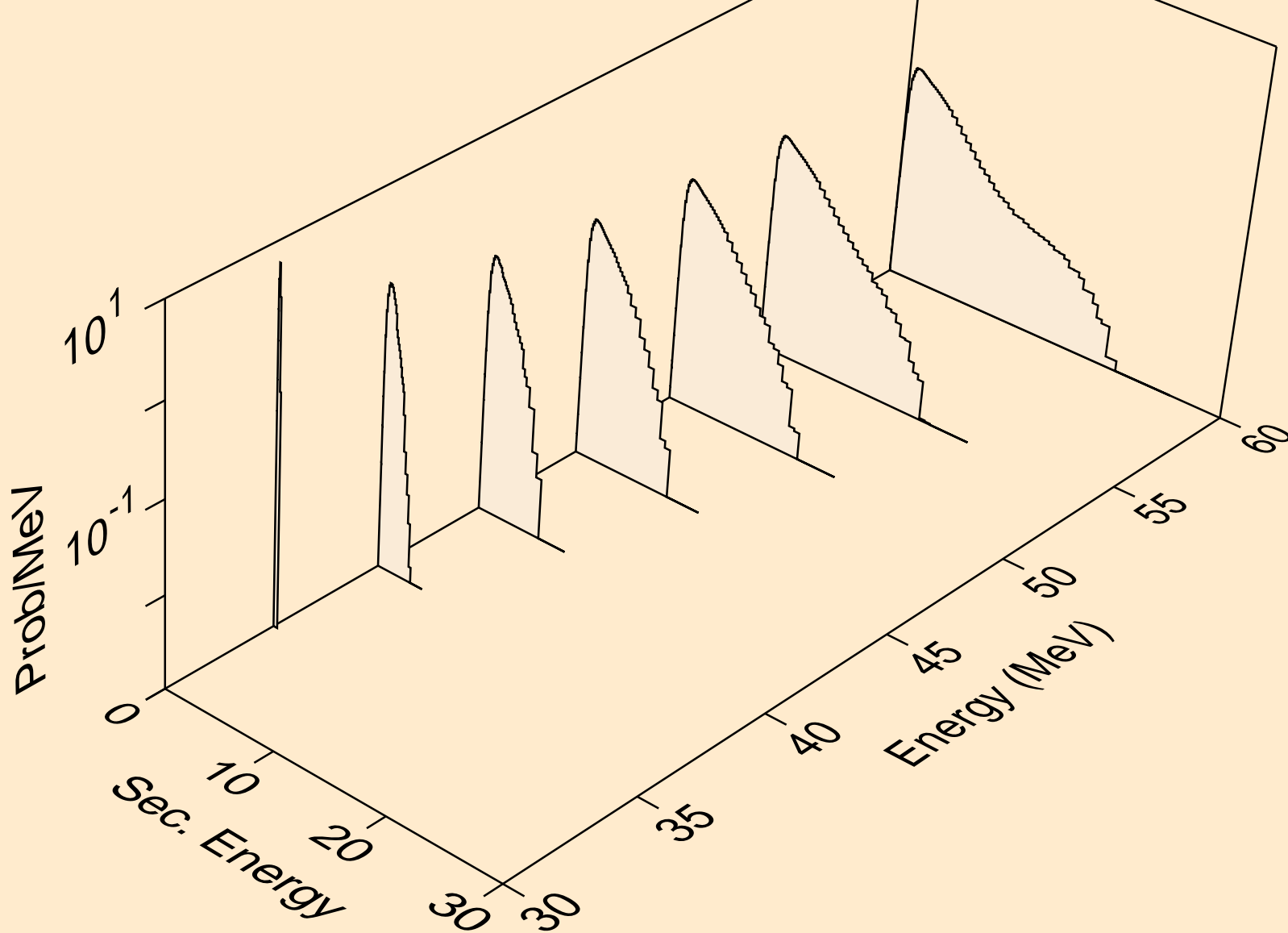

16-S-34 FOR FENDL-3.1 FROM TENDL-2010 WITH NJOY2012.50+
Neutron emission for (n,4np)

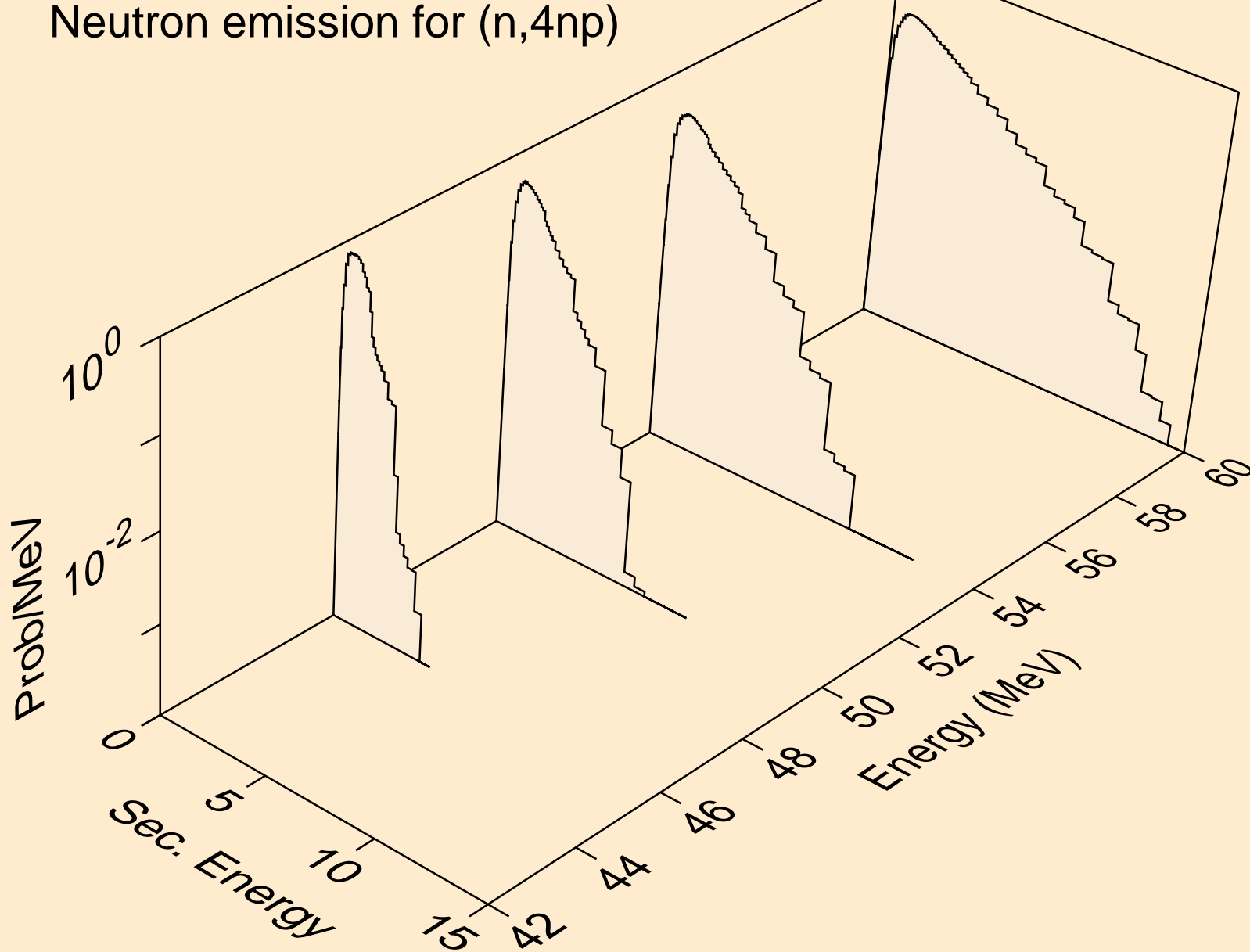

16-S-34 FOR FENDL-3.1 FROM TENDL-2010 WITH NJOY2012.50+
Neutron emission for (n,3nd)

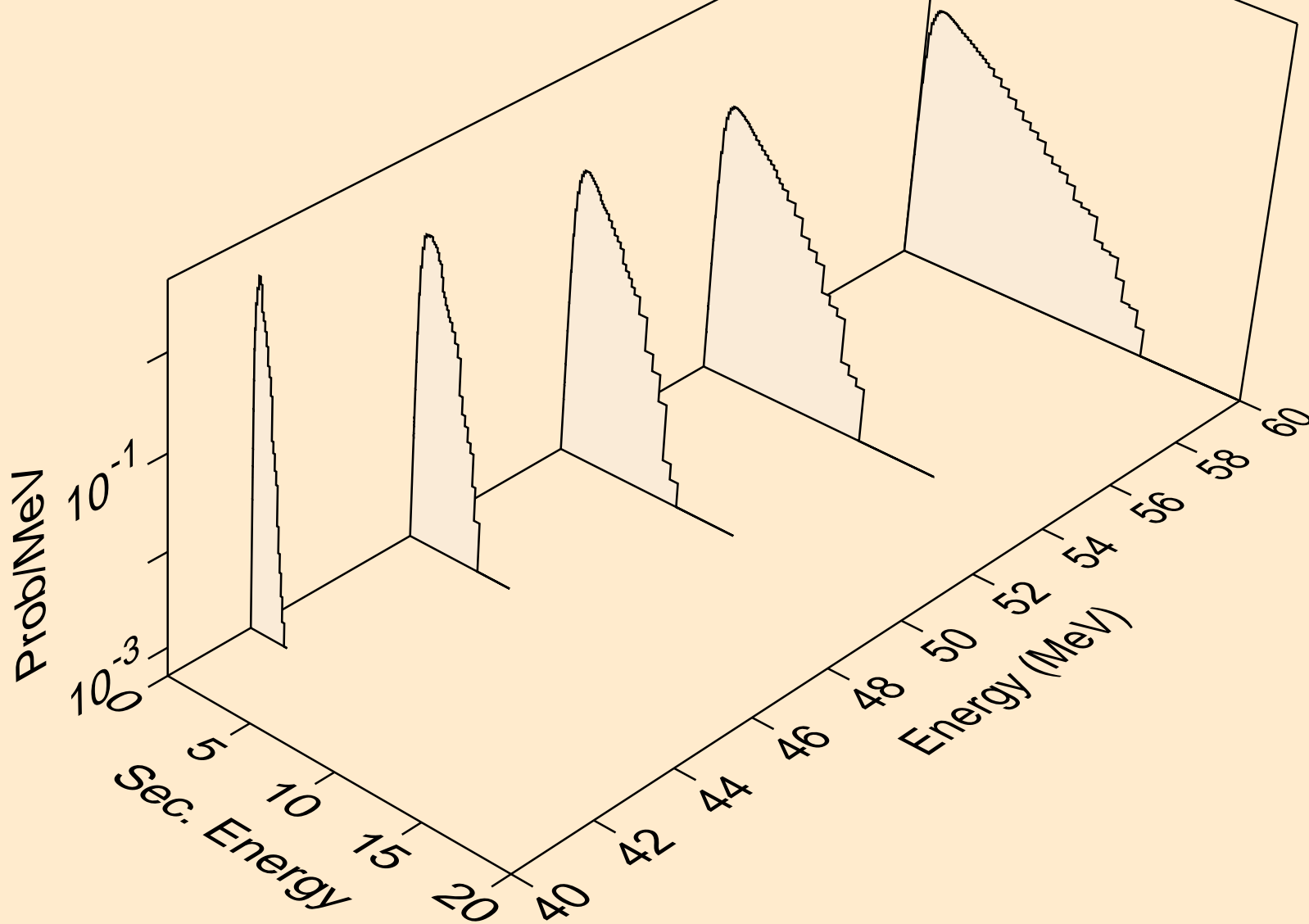

16-S-34 FOR FENDL-3.1 FROM TENDL-2010 WITH NJOY2012.50+
Neutron emission for (n,nda)

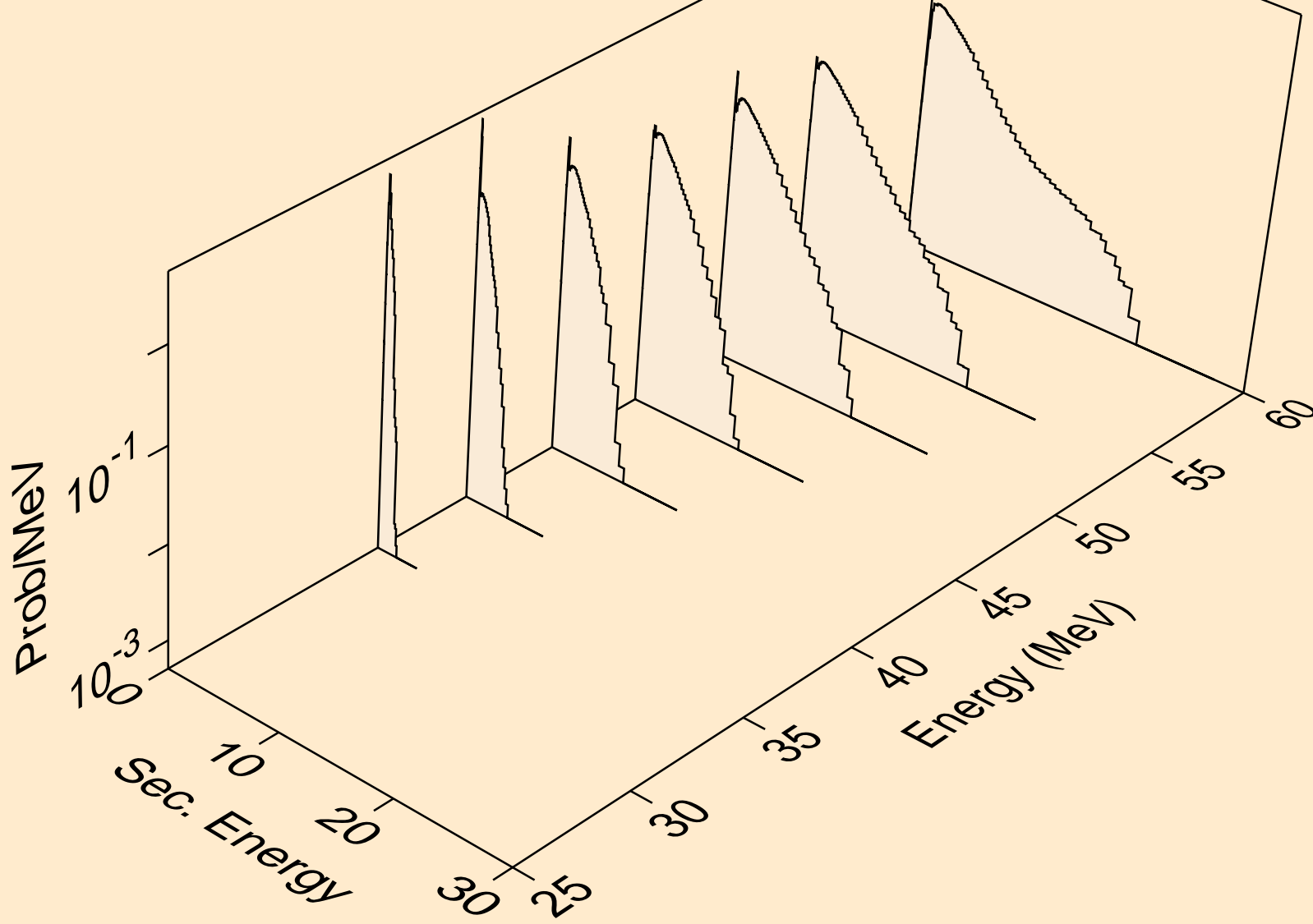

16-S-34 FOR FENDL-3.1 FROM TENDL-2010 WITH NJOY2012.50+
Neutron emission for (n,2npa)

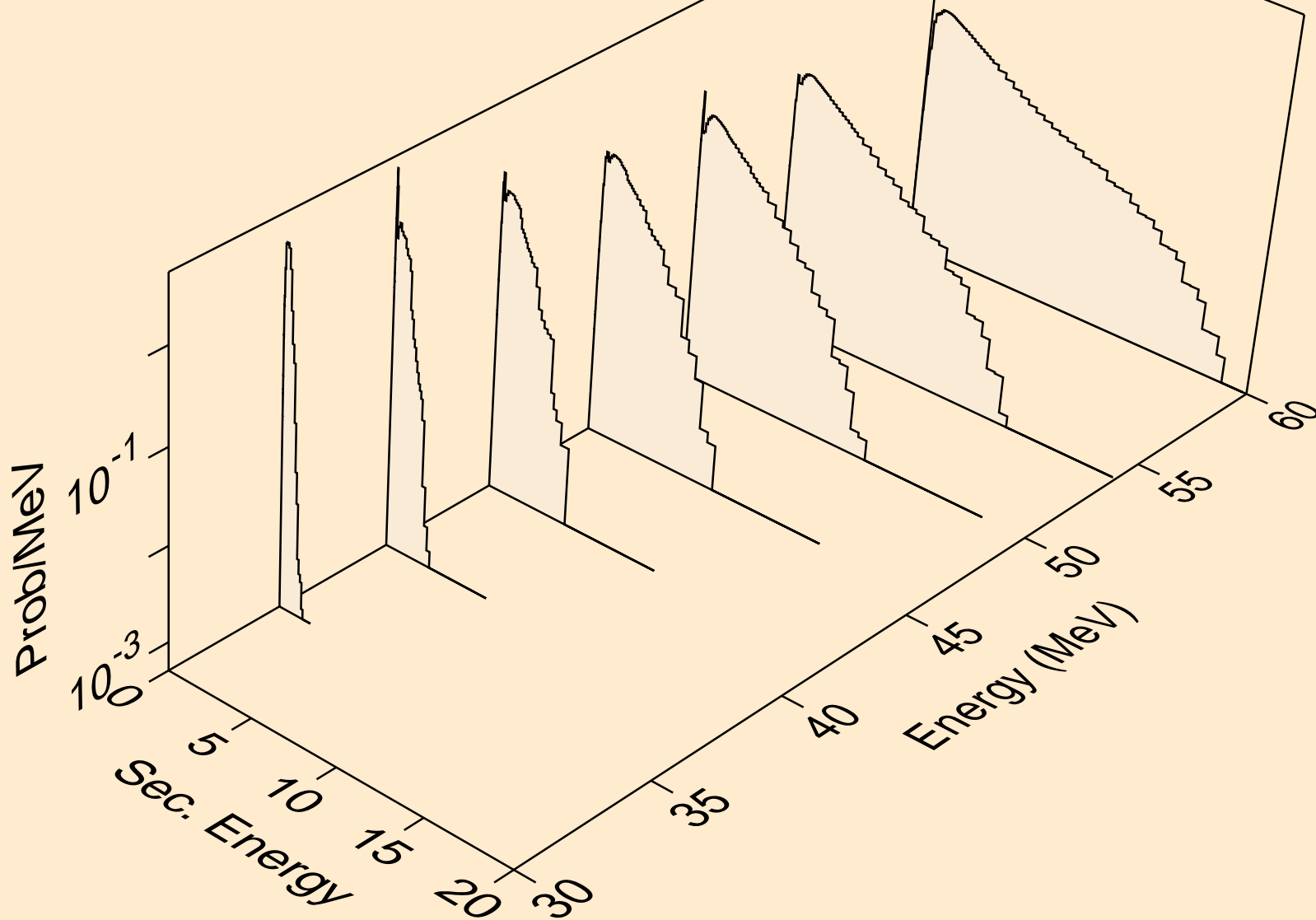

16-S-34 FOR FENDL-3.1 FROM TENDL-2010 WITH NJOY2012.50+
Neutron emission for (n,5np)

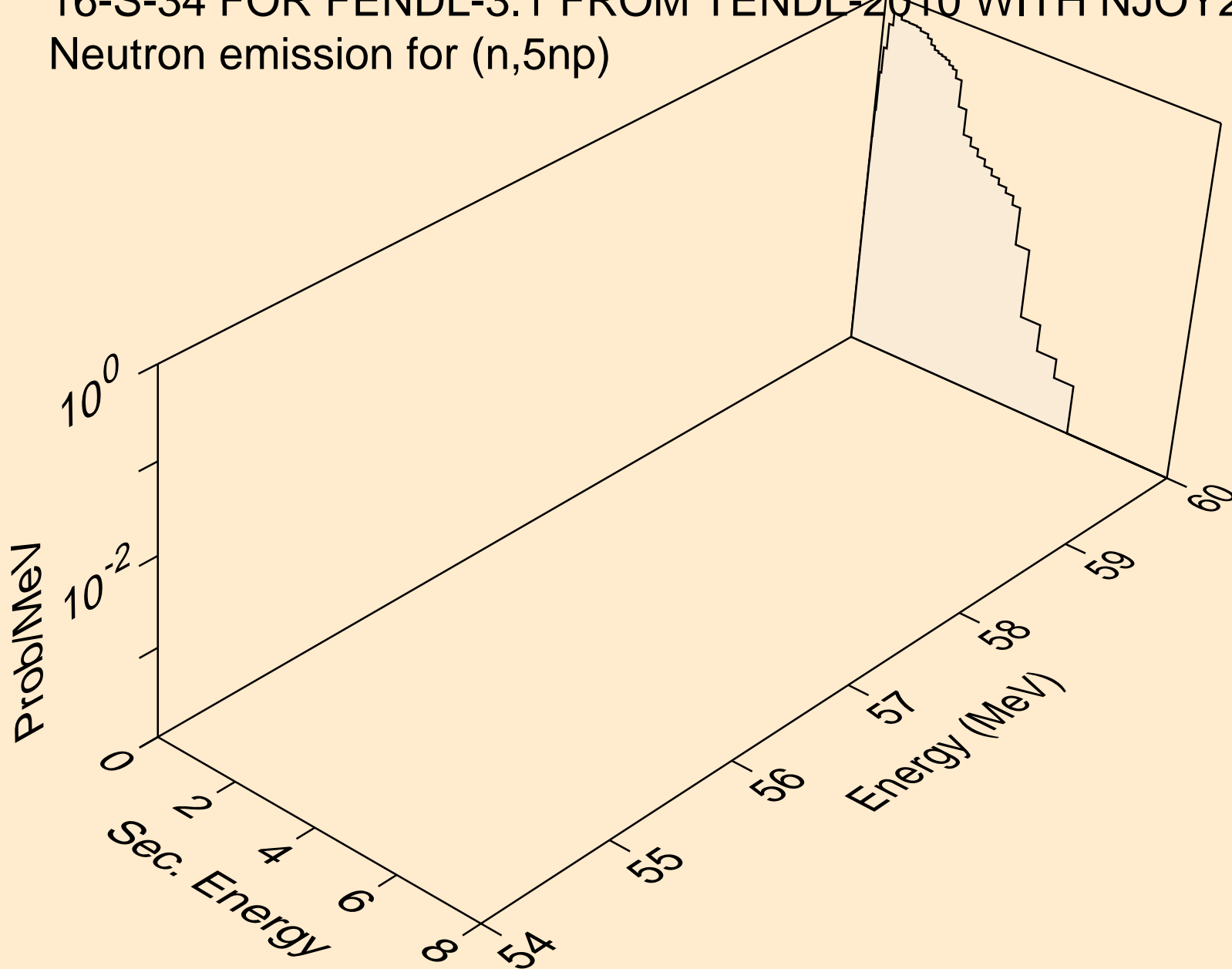

16-S-34 FOR FENDL-3.1 FROM TENDL-2010 WITH NJOY2012.50+
Neutron emission for (n,4na)

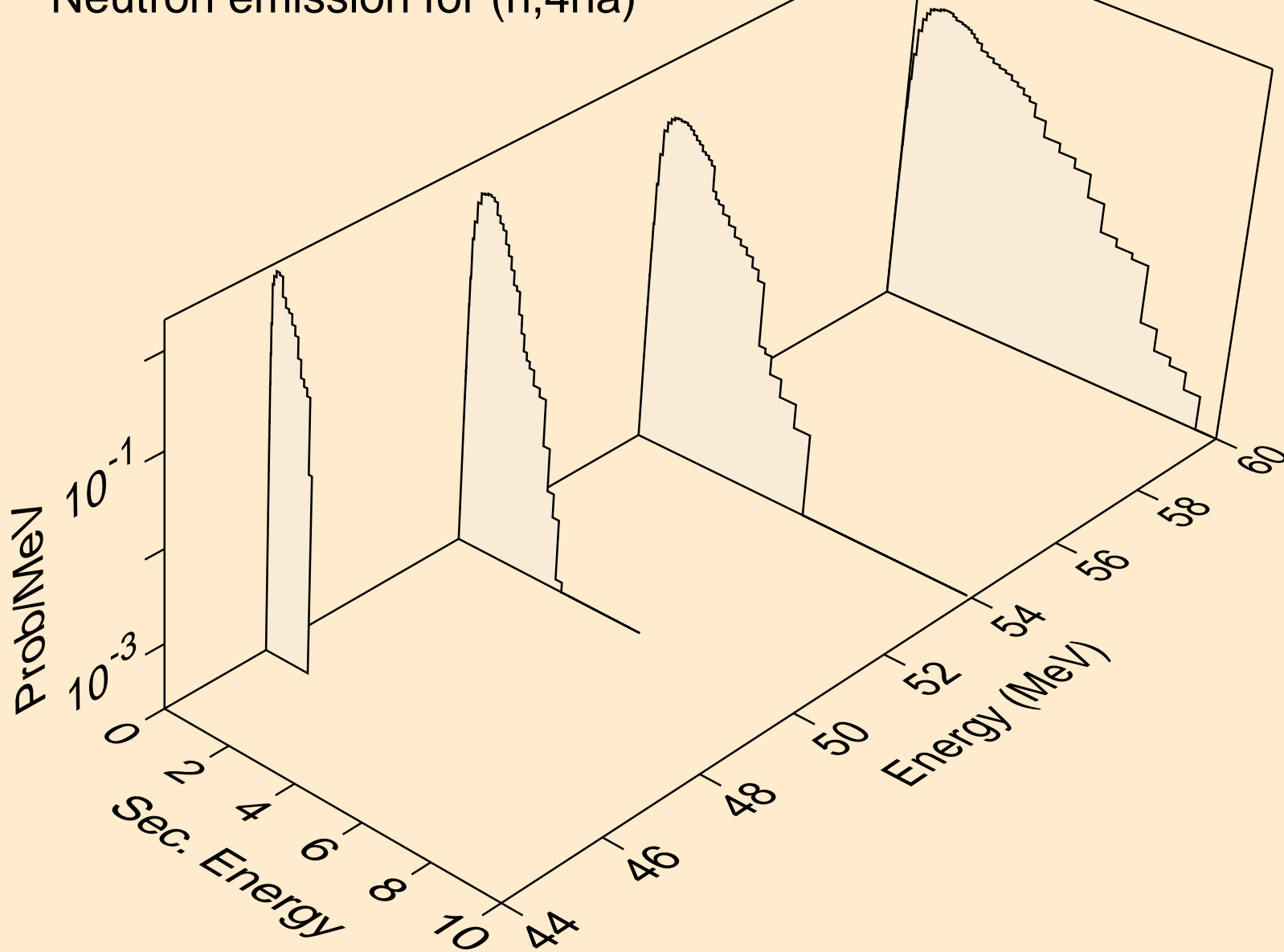

16-S-34 FOR FENDL-3.1 FROM TENDL-2010 WITH NJOY2012.50+
Neutron emission for (n,4nd)

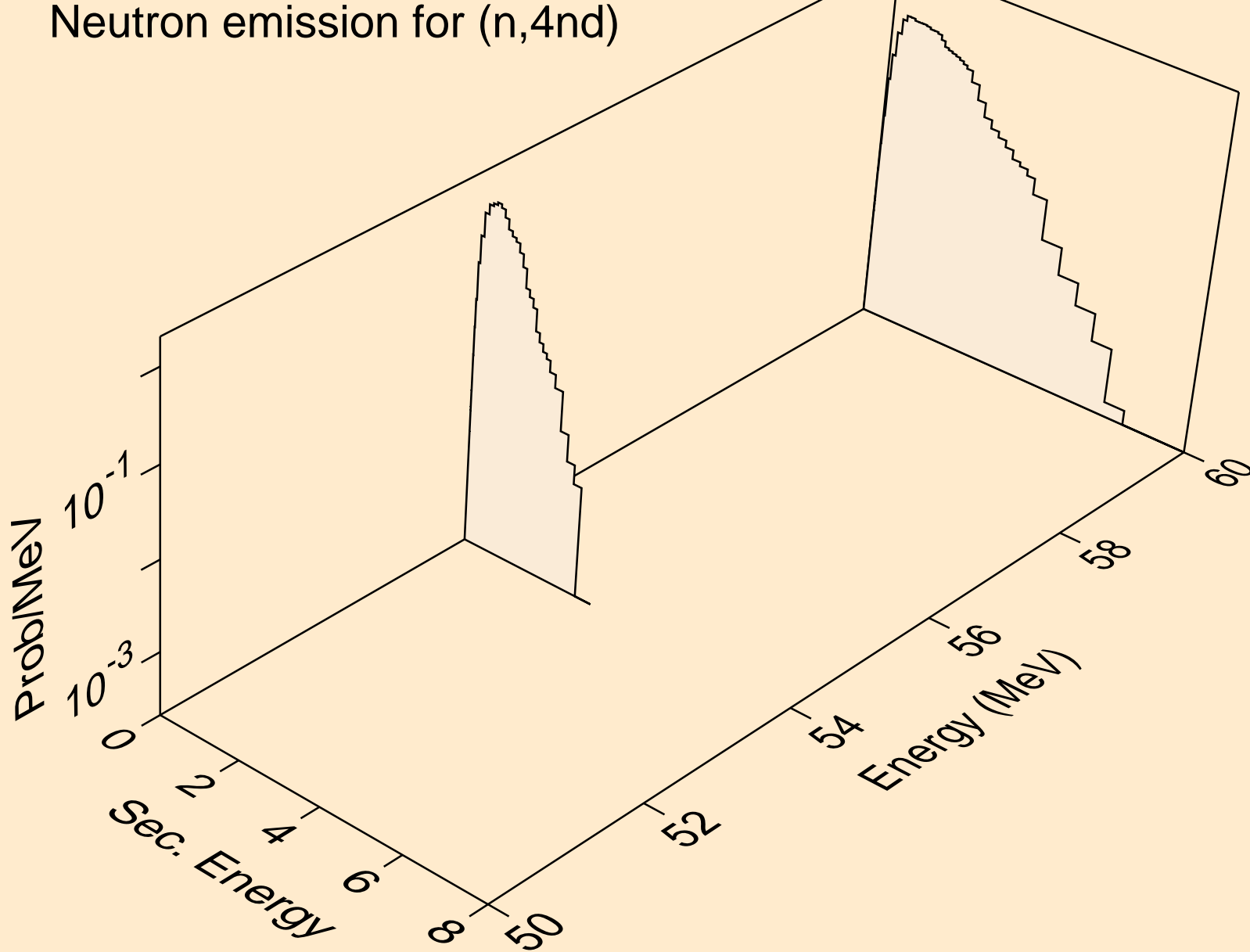

16-S-34 FOR FENDL-3.1 FROM TENDL-2010 WITH NJOY2012.50+
Neutron emission for (n,3nt)

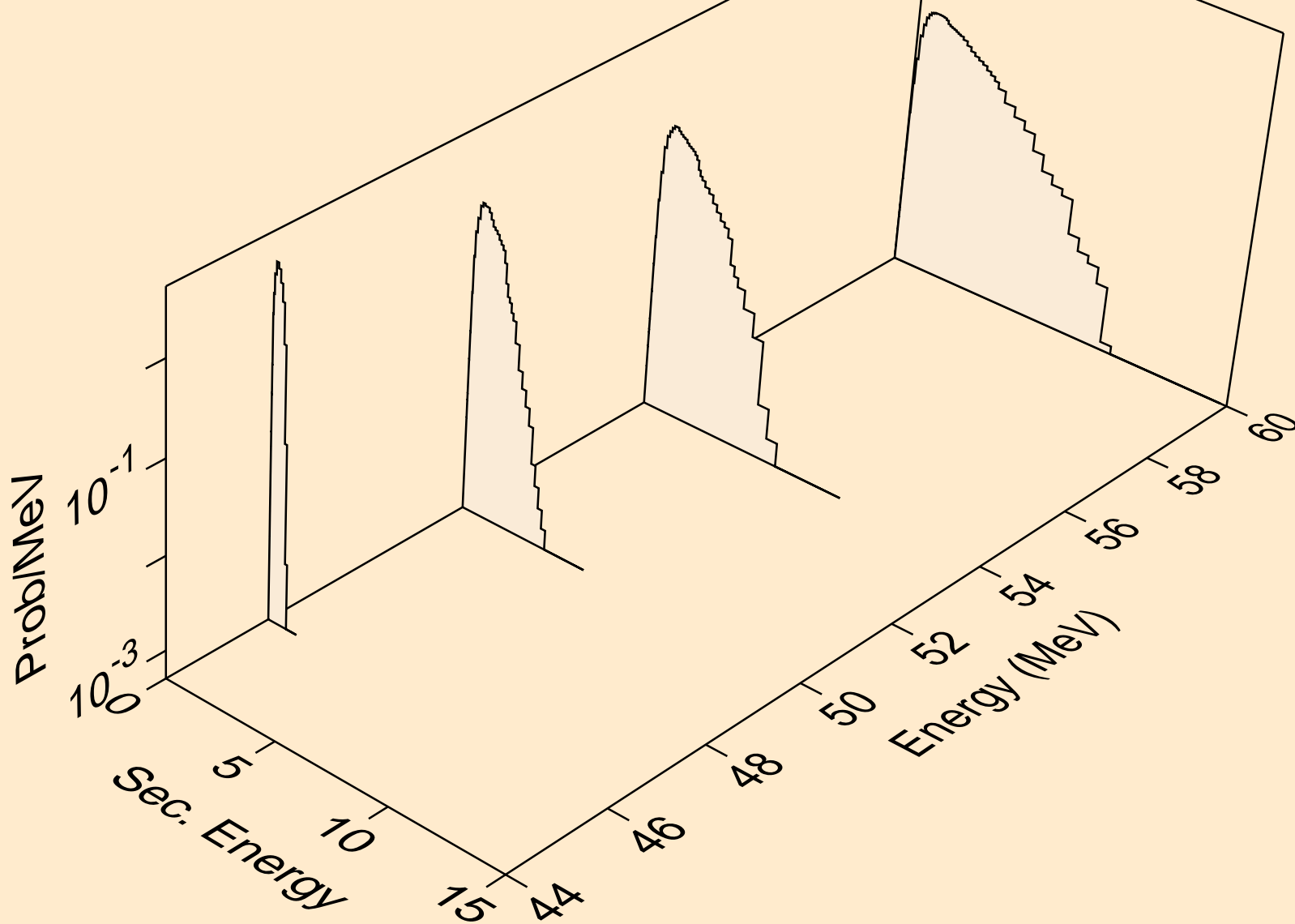

16-S-34 FOR FENDL-3.1 FROM TENDL-2010 WITH NJOY2012.50+
Neutron emission for (n,2n)he3)

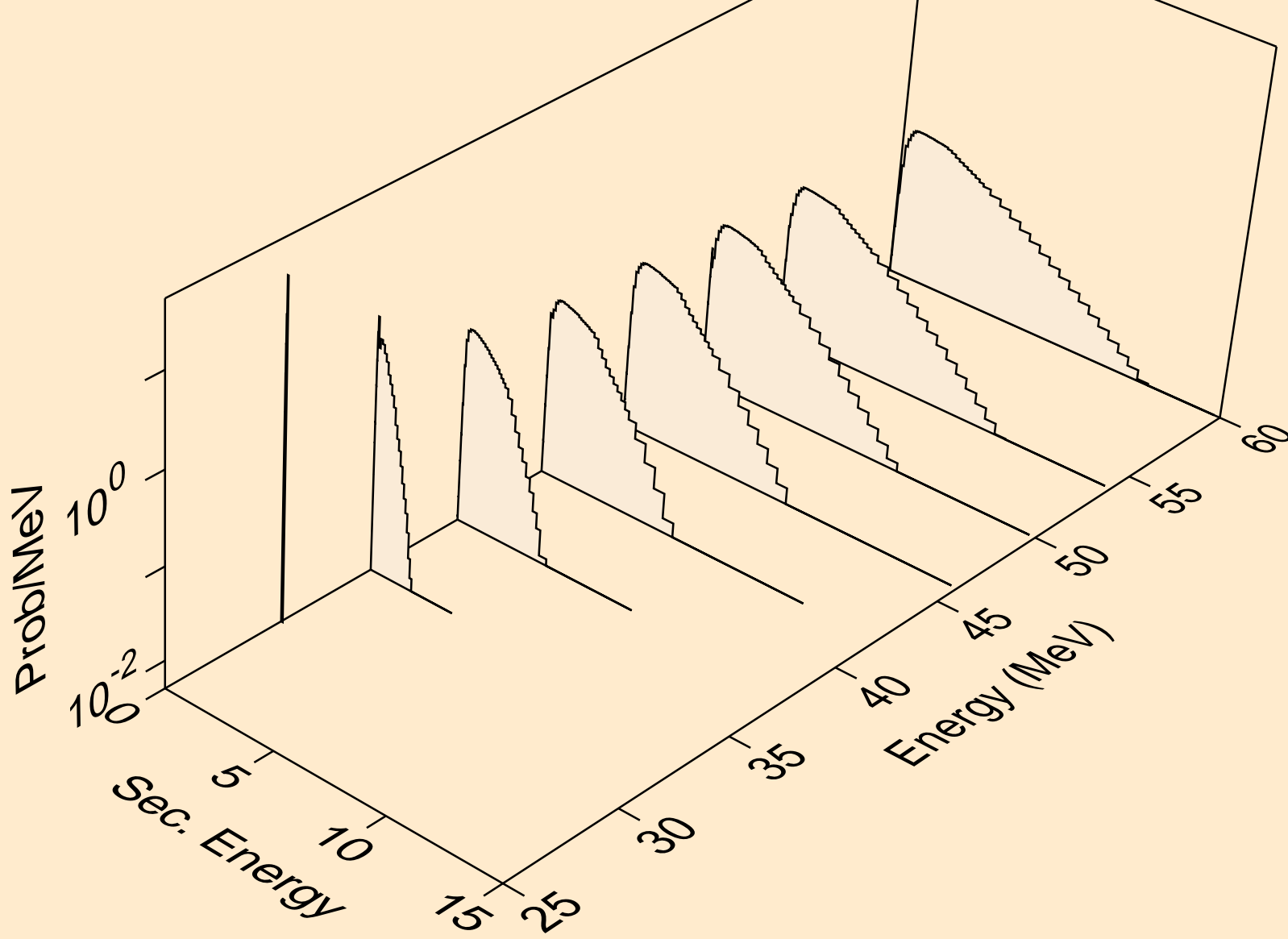

16-S-34 FOR FENDL-3.1 FROM TENDL-2010 WITH NJOY2012.50+
Neutron emission for (n,3n)he3

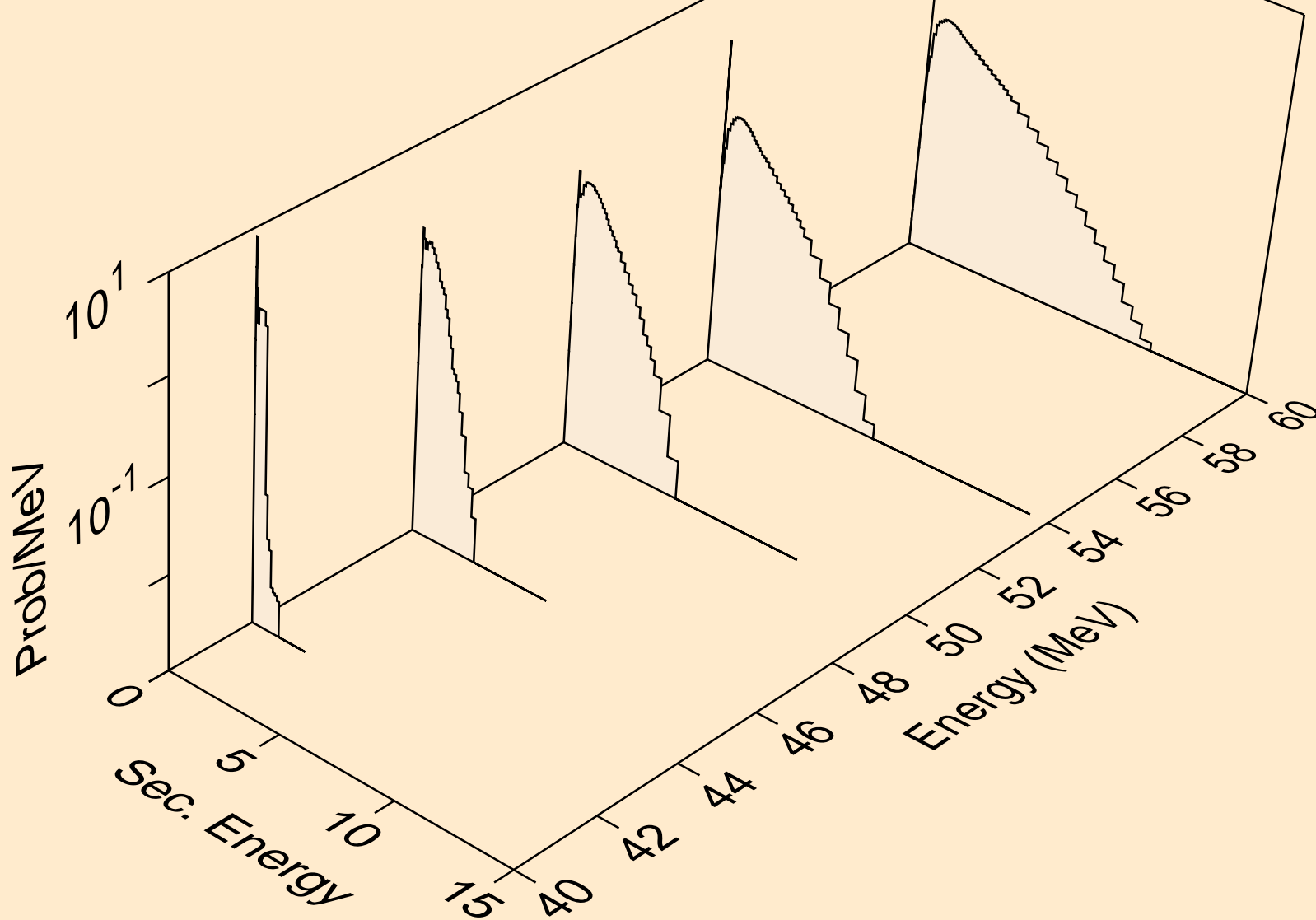

16-S-34 FOR FENDL-3.1 FROM TENDL-2010 WITH NJOY2012.50+
Neutron emission for (n,4nhe3)

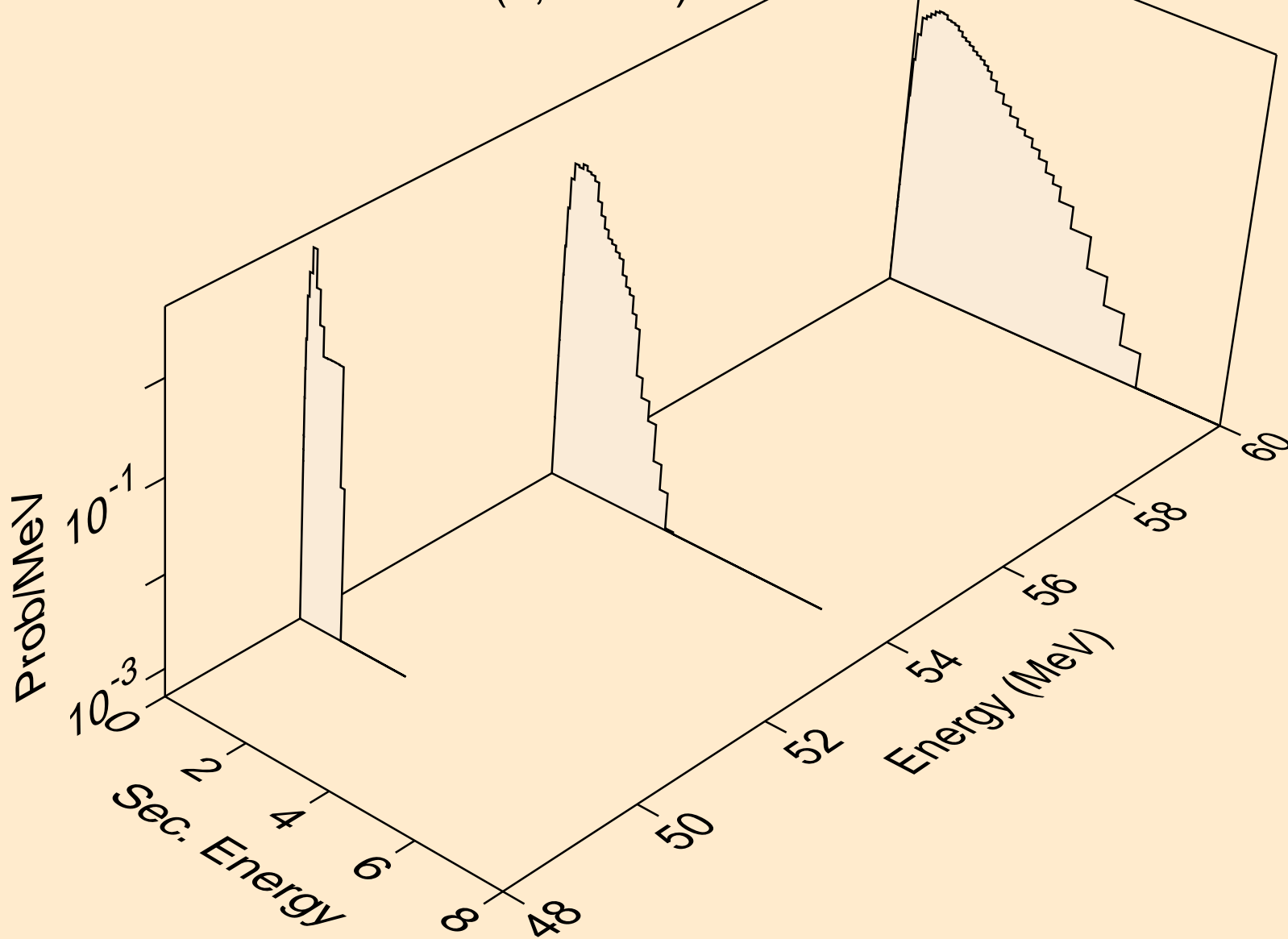

16-S-34 FOR FENDL-3.1 FROM TENDL-2010 WITH NJOY2012.50+
Neutron emission for (n,3n2p)

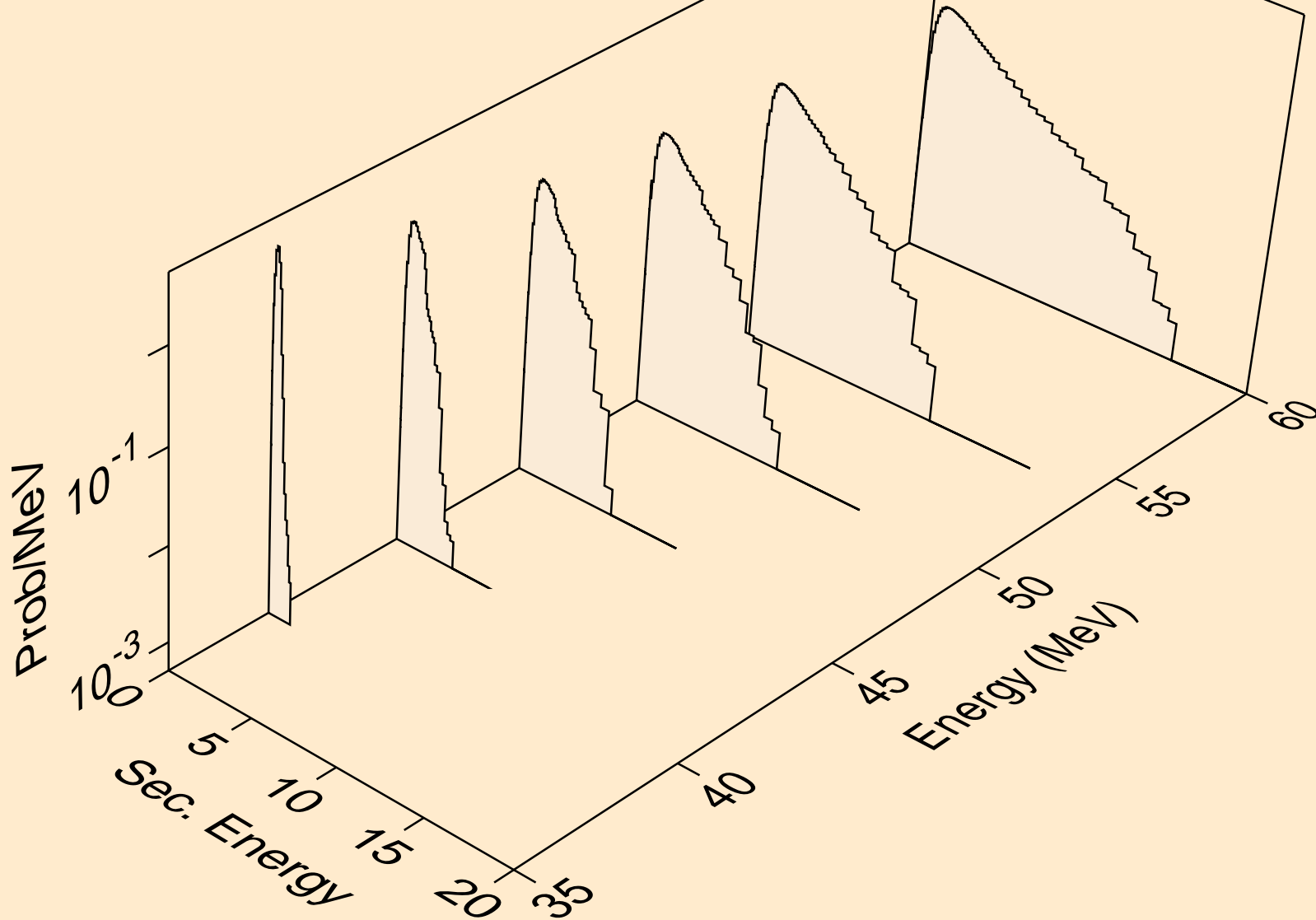

16-S-34 FOR FENDL-3.1 FROM TENDL-2010 WITH NJOY2012.50+
Neutron emission for (n,3n2a)

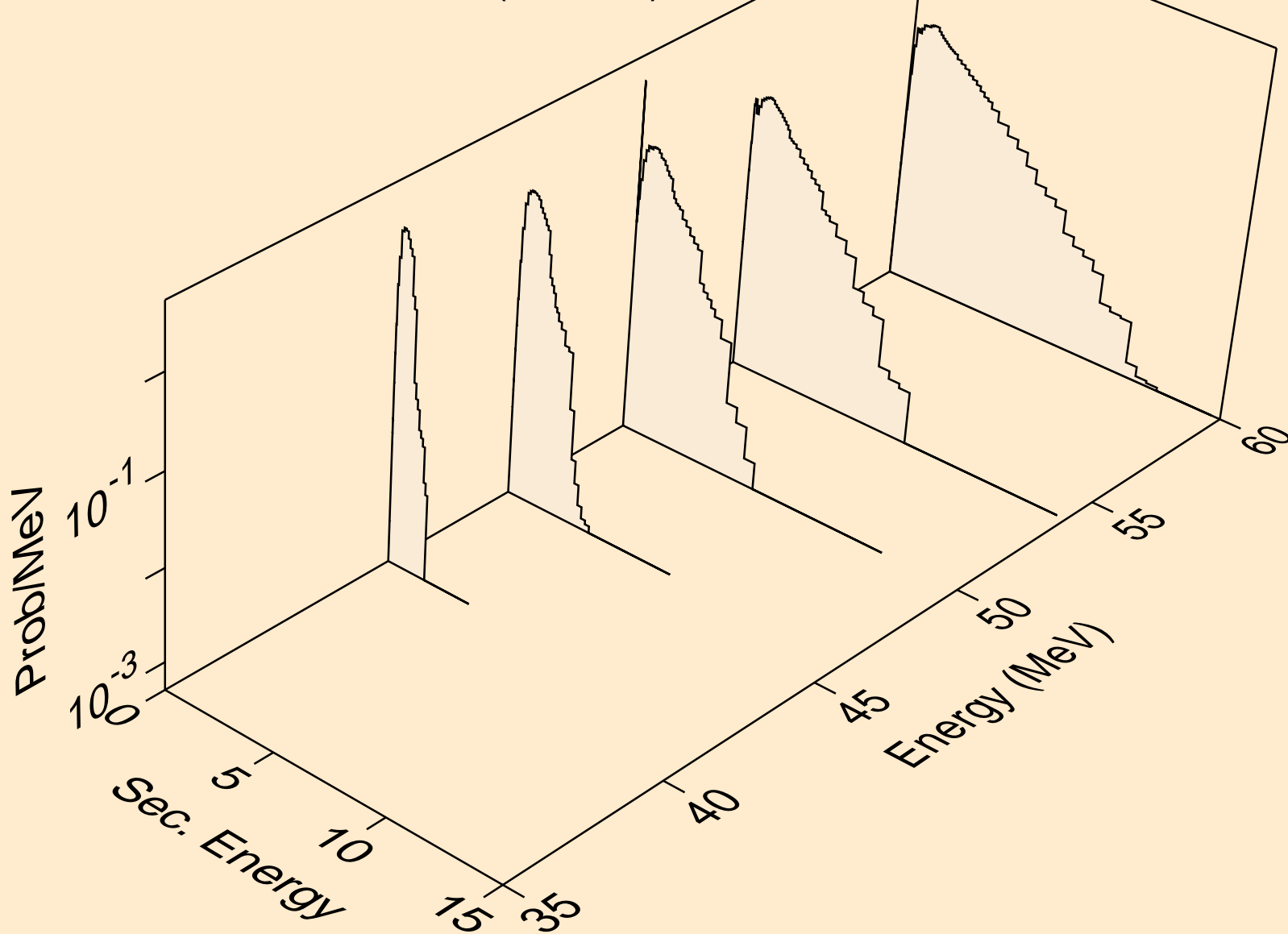

16-S-34 FOR FENDL-3.1 FROM TENDL-2010 WITH NJOY2012.50+
Neutron emission for (n,3npa)

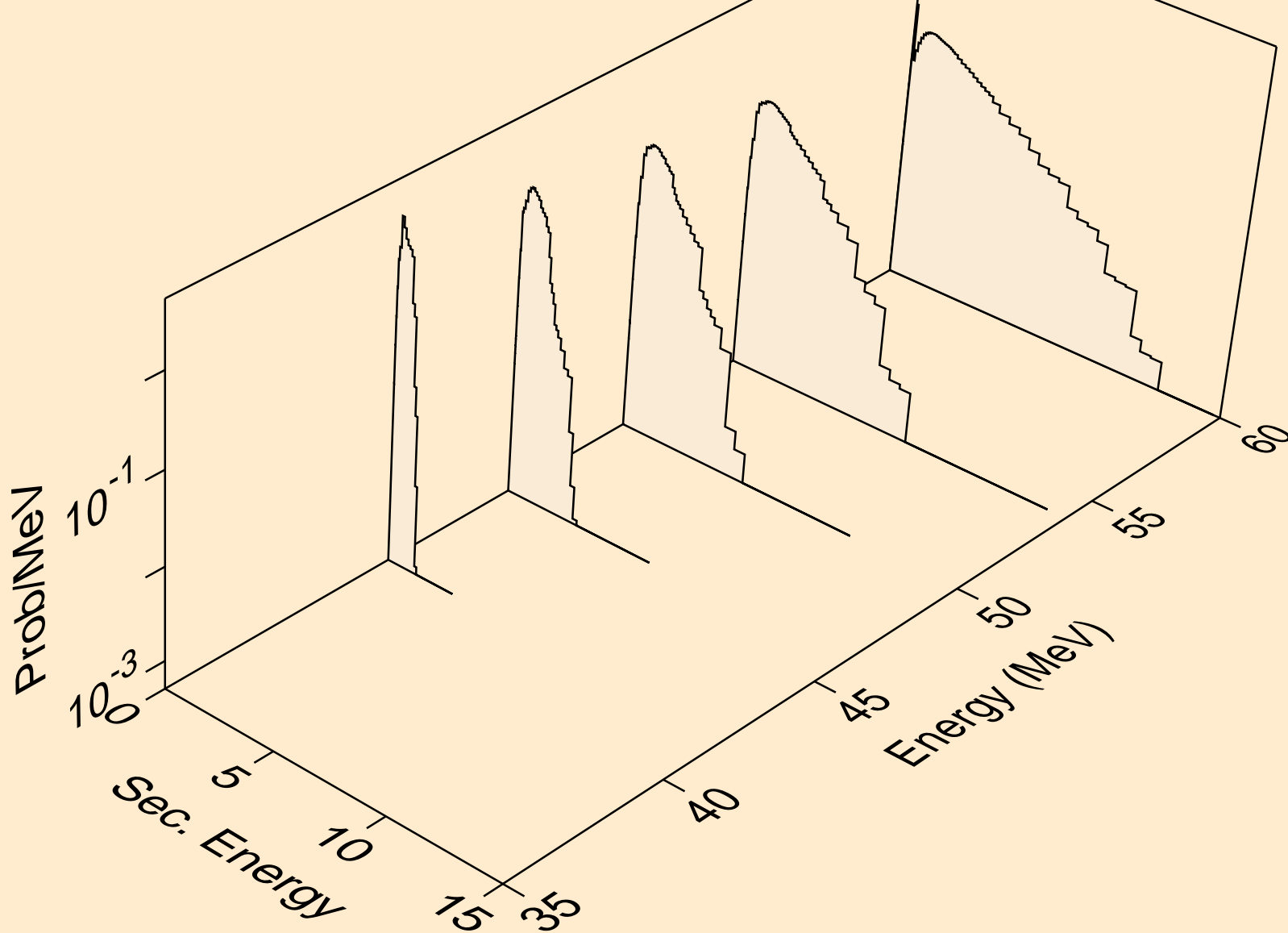

16-S-34 FOR FENDL-3.1 FROM TENDL-2010 WITH NJOY2012.50+
Neutron emission for (n,npd)

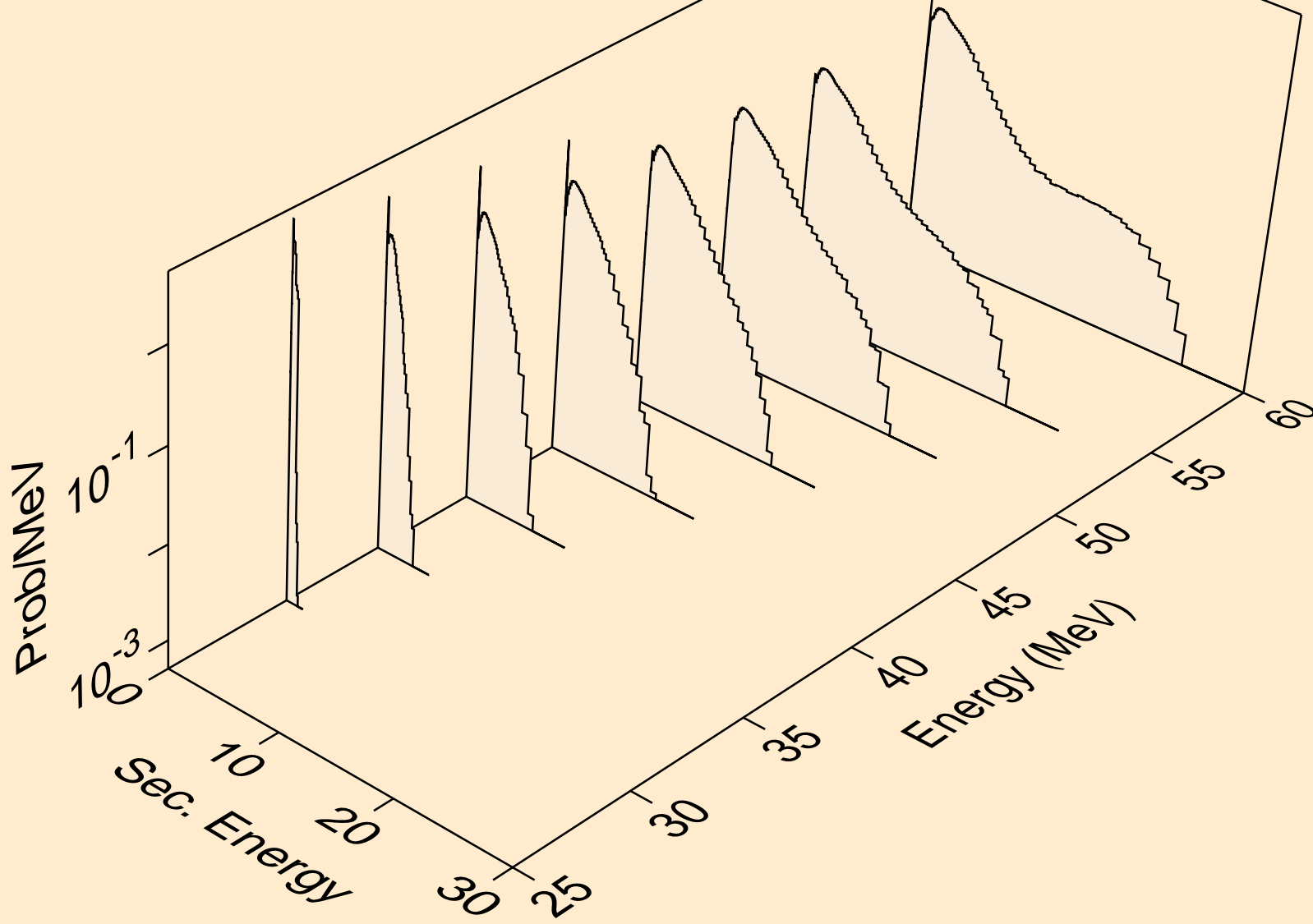

16-S-34 FOR FENDL-3.1 FROM TENDL-2010 WITH NJOY2012.50+
Neutron emission for (n,npt)

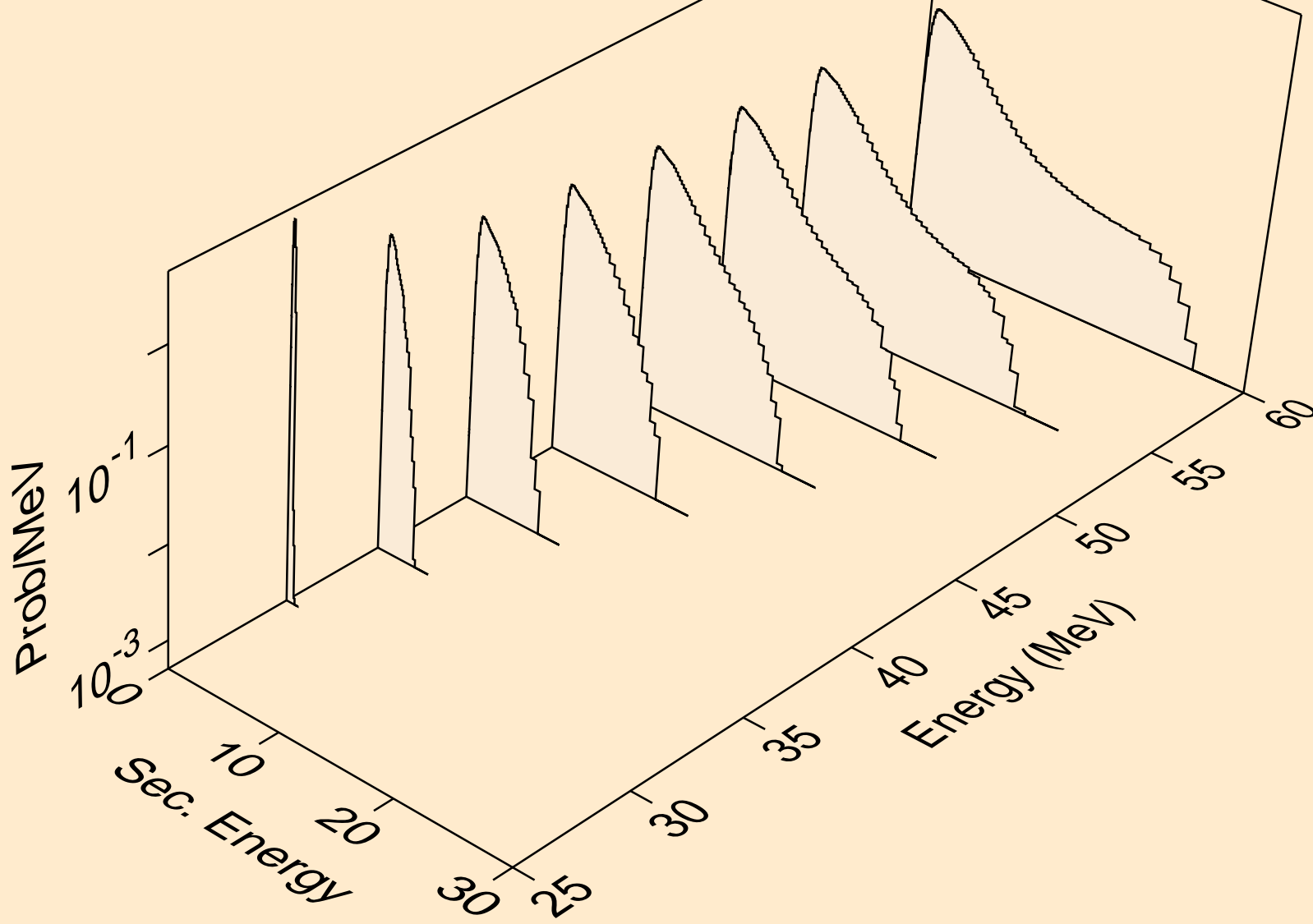

16-S-34 FOR FENDL-3.1 FROM TENDL-2010 WITH NJOY2012.50+
Neutron emission for (n,ndt)

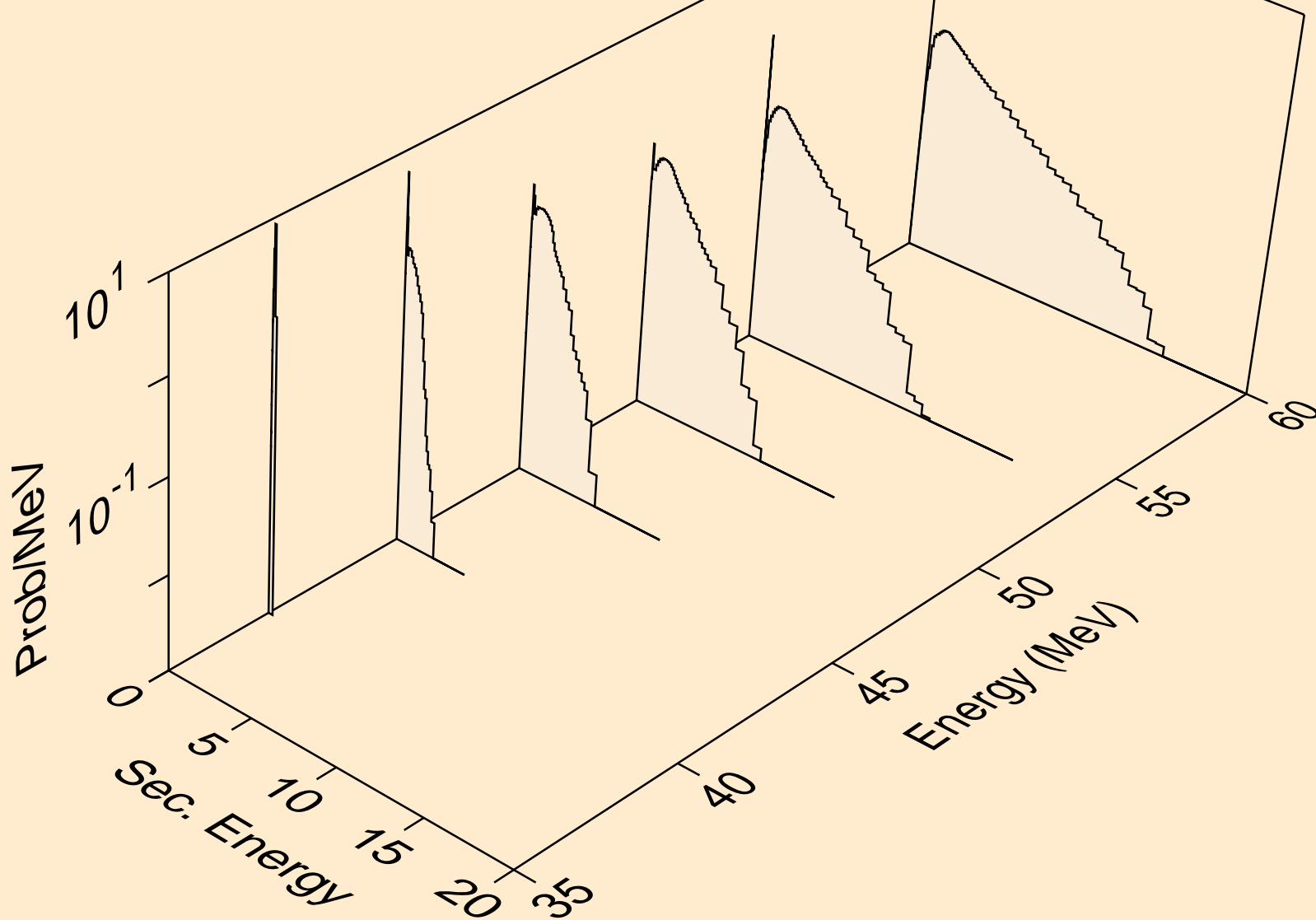

16-S-34 FOR FENDL-3.1 FROM TENDL-2010 WITH NJOY2012.50+
Neutron emission for (n,nphe3)

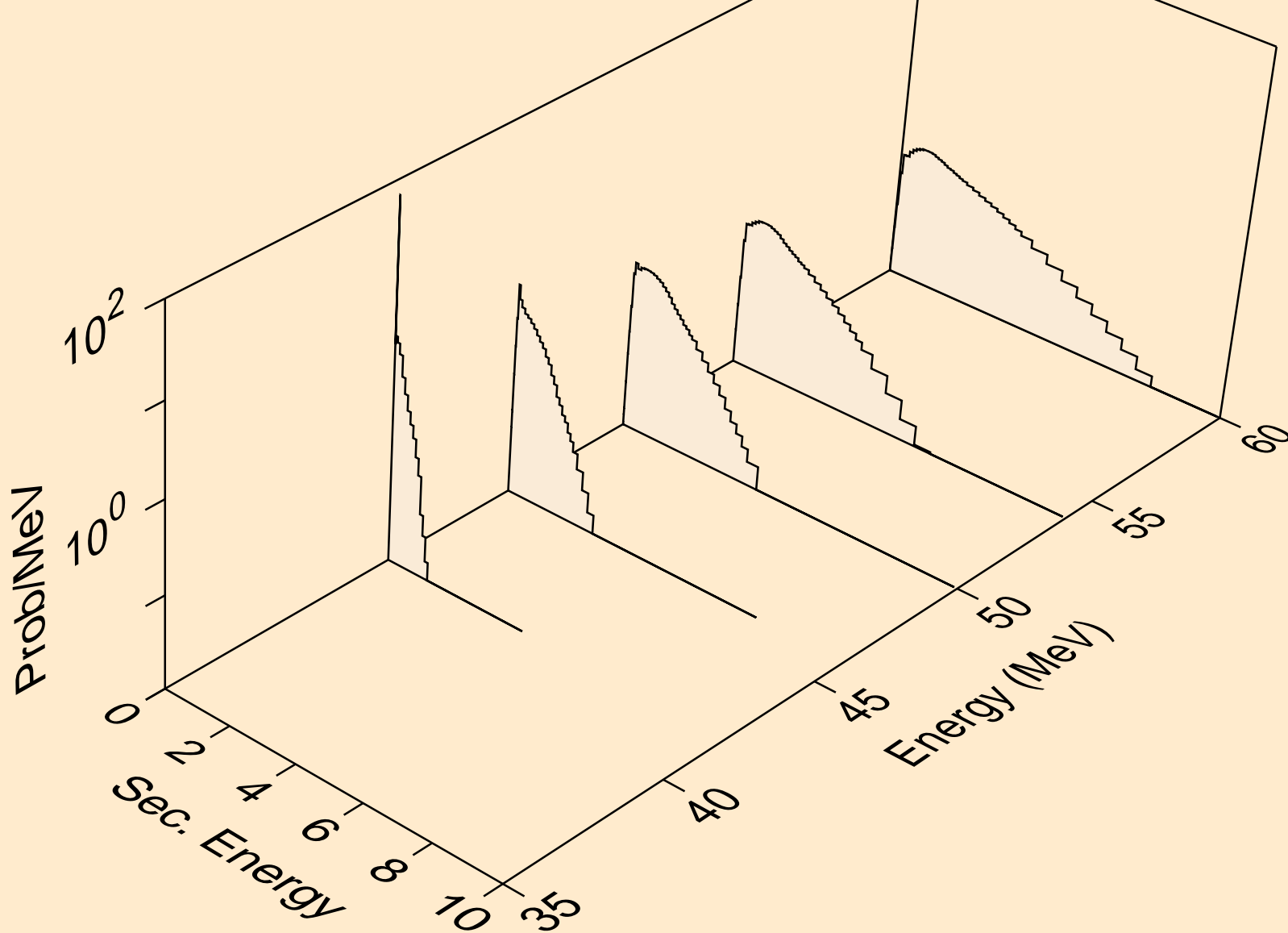

16-S-34 FOR FENDL-3.1 FROM TENDL-2010 WITH NJOY2012.50+
Neutron emission for (n,ndhe3)

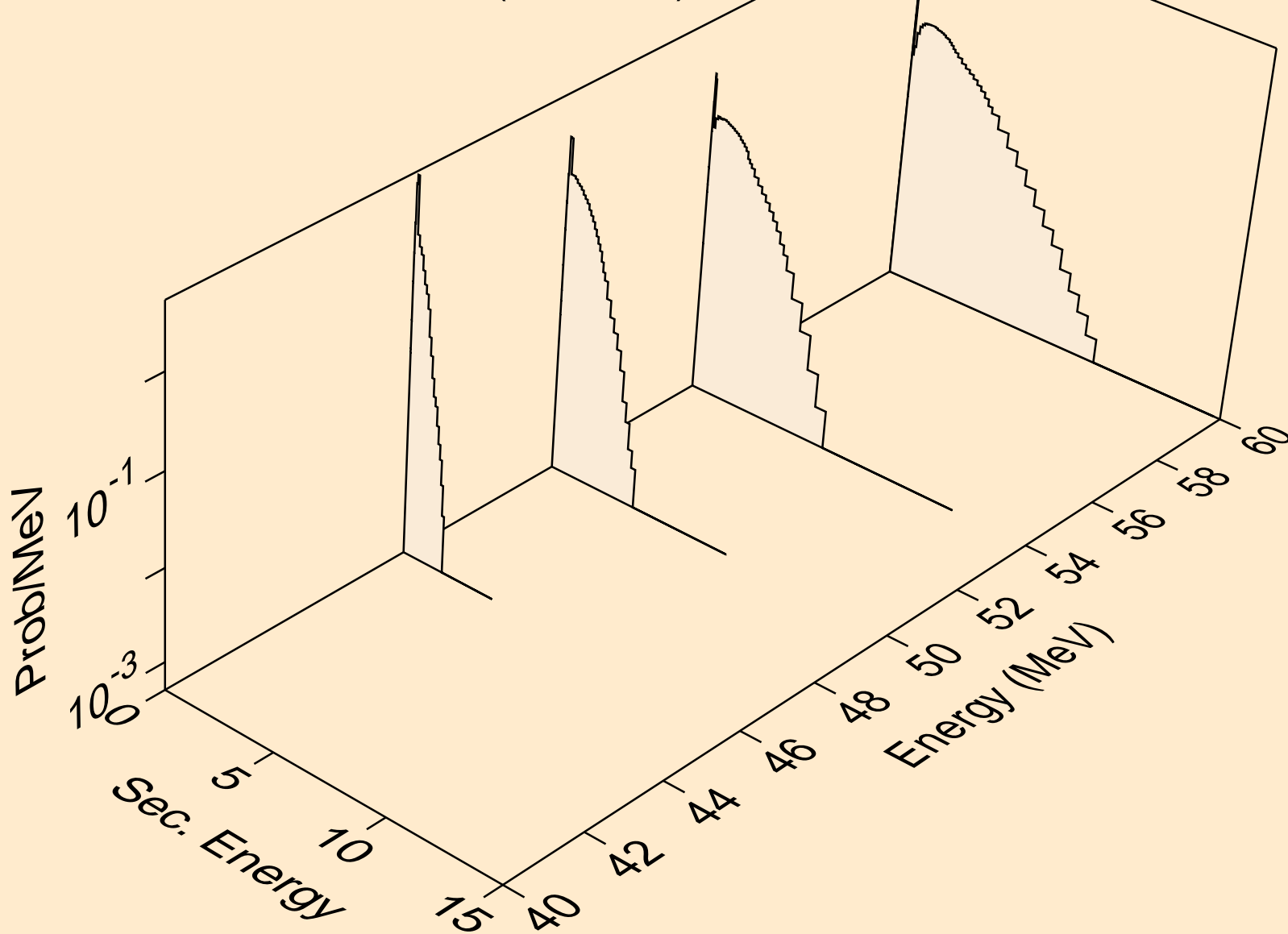

16-S-34 FOR FENDL-3.1 FROM TENDL-2010 WITH NJOY2012.50+
Neutron emission for (n,nthe3)

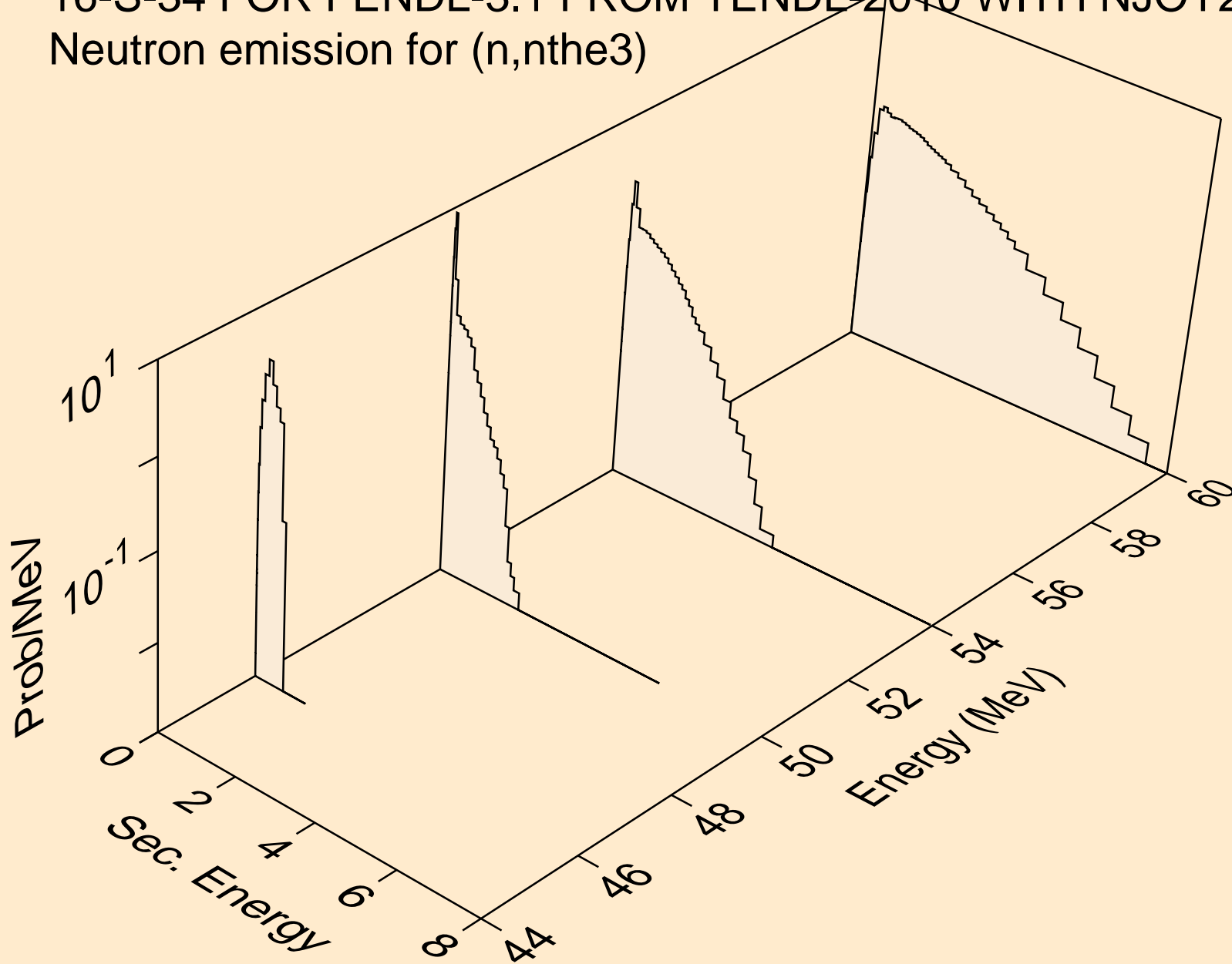

16-S-34 FOR FENDL-3.1 FROM TENDL-2010 WITH NJOY2012.50+
Neutron emission for (n,nta)

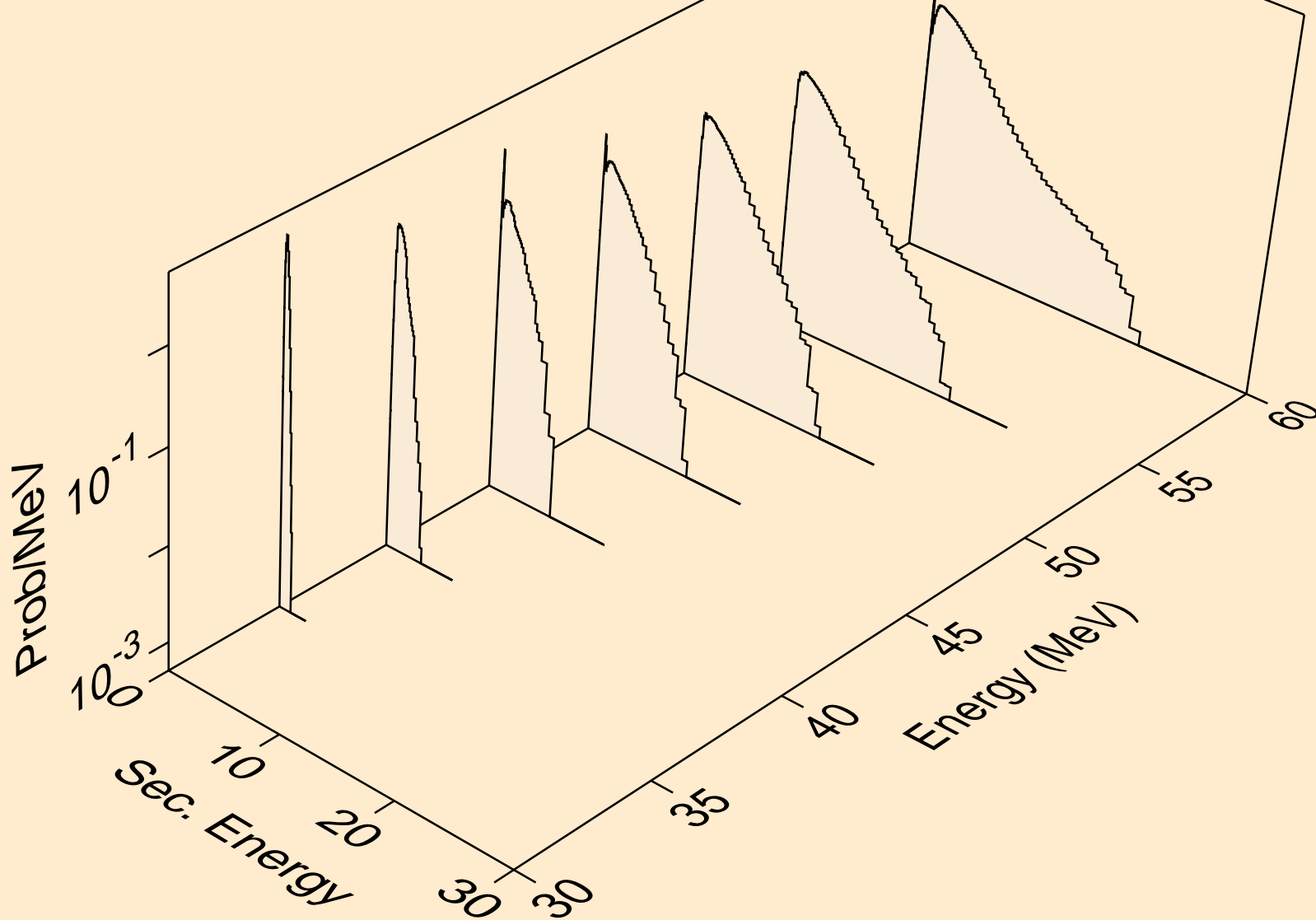

16-S-34 FOR FENDL-3.1 FROM TENDL-2010 WITH NJOY2012.50+
Neutron emission for (n,2n2p)

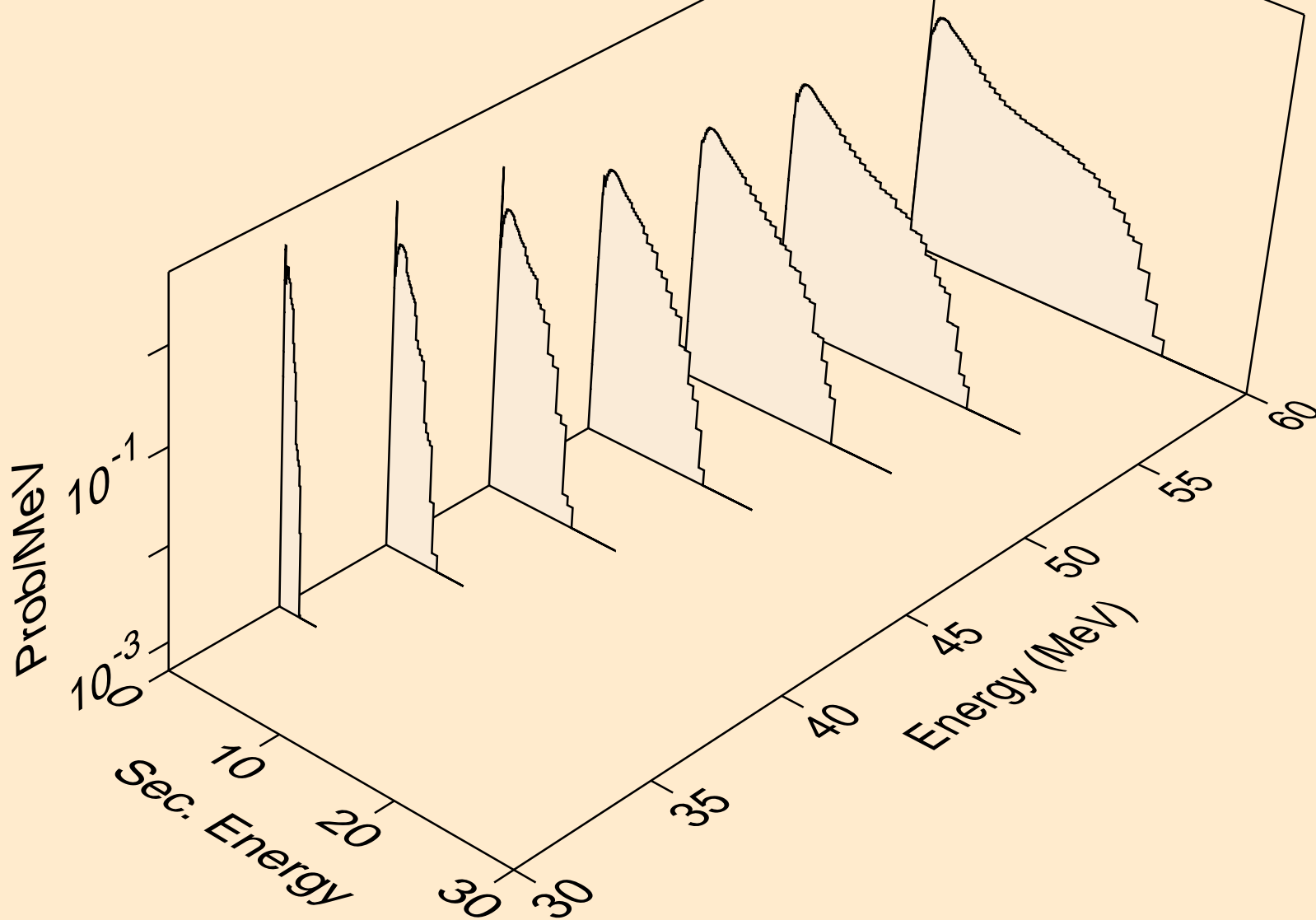

16-S-34 FOR FENDL-3.1 FROM TENDL-2010 WITH NJOY2012.50+
Neutron emission for (n,4n2p)

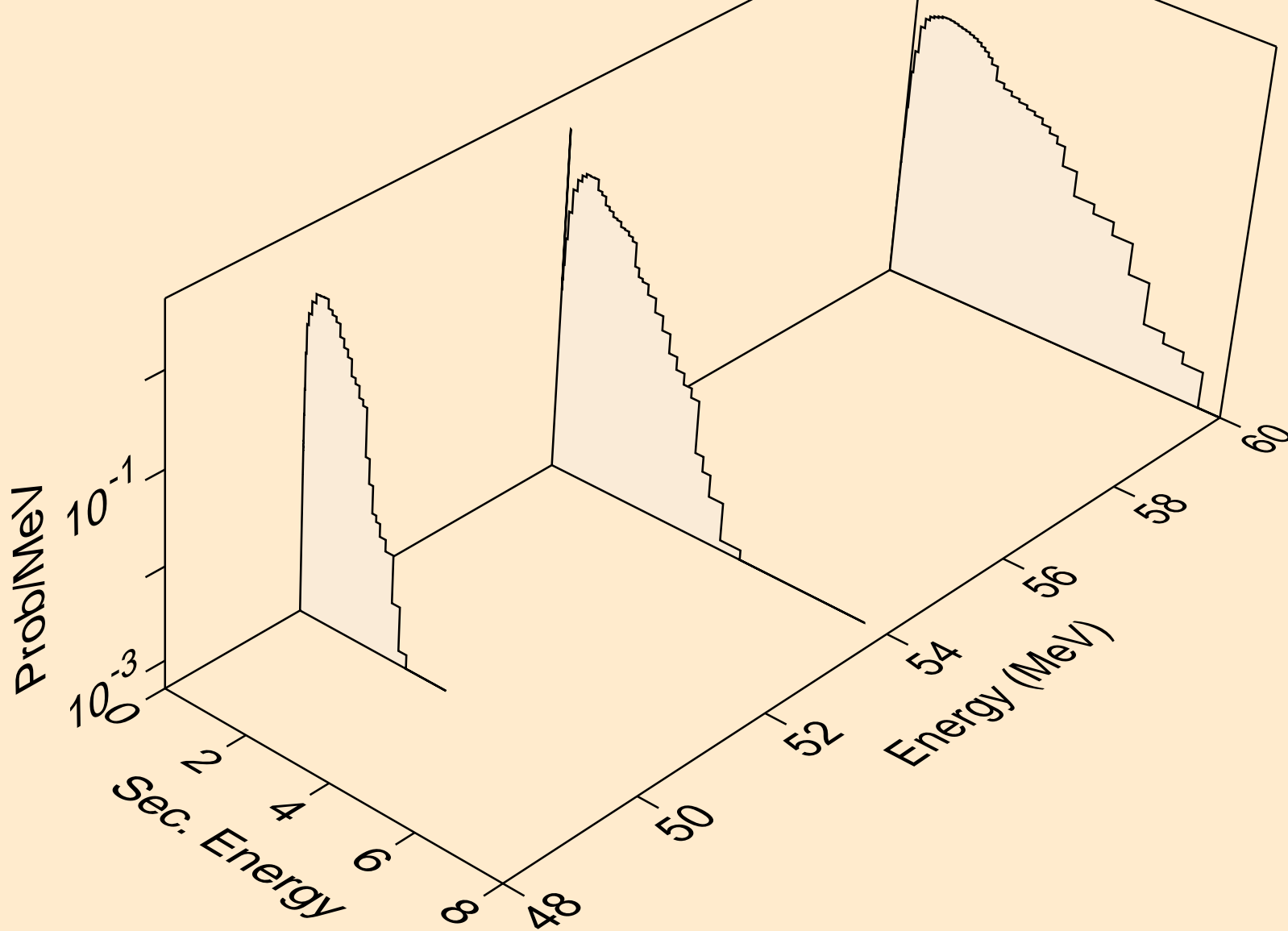

16-S-34 FOR FENDL-3.1 FROM TENDL-2010 WITH NJOY2012.50+
Neutron emission for (n,4npa)

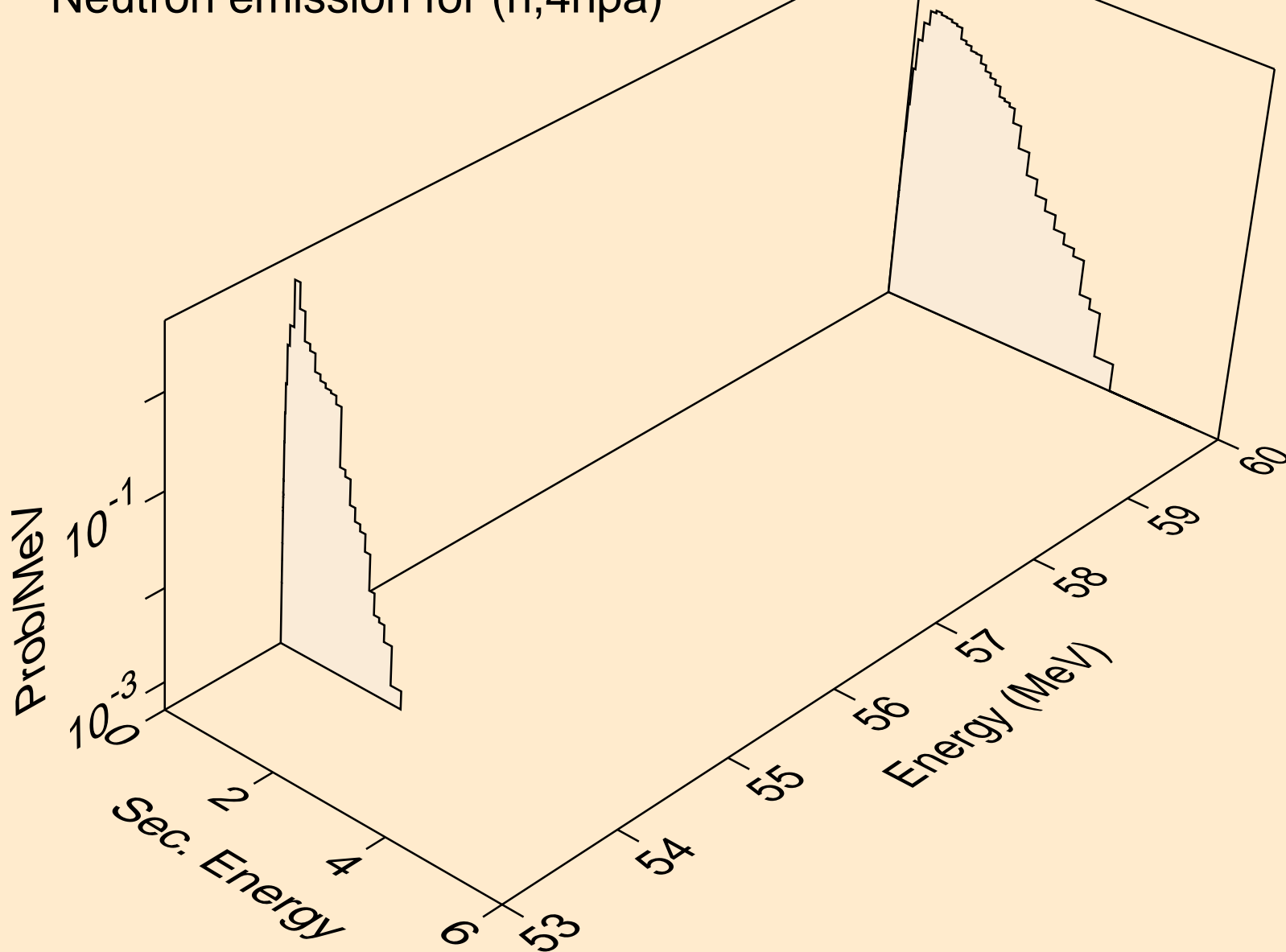

16-S-34 FOR FENDL-3.1 FROM TENDL-2010 WITH NJOY2012.50+
Neutron emission for (n,n3p)

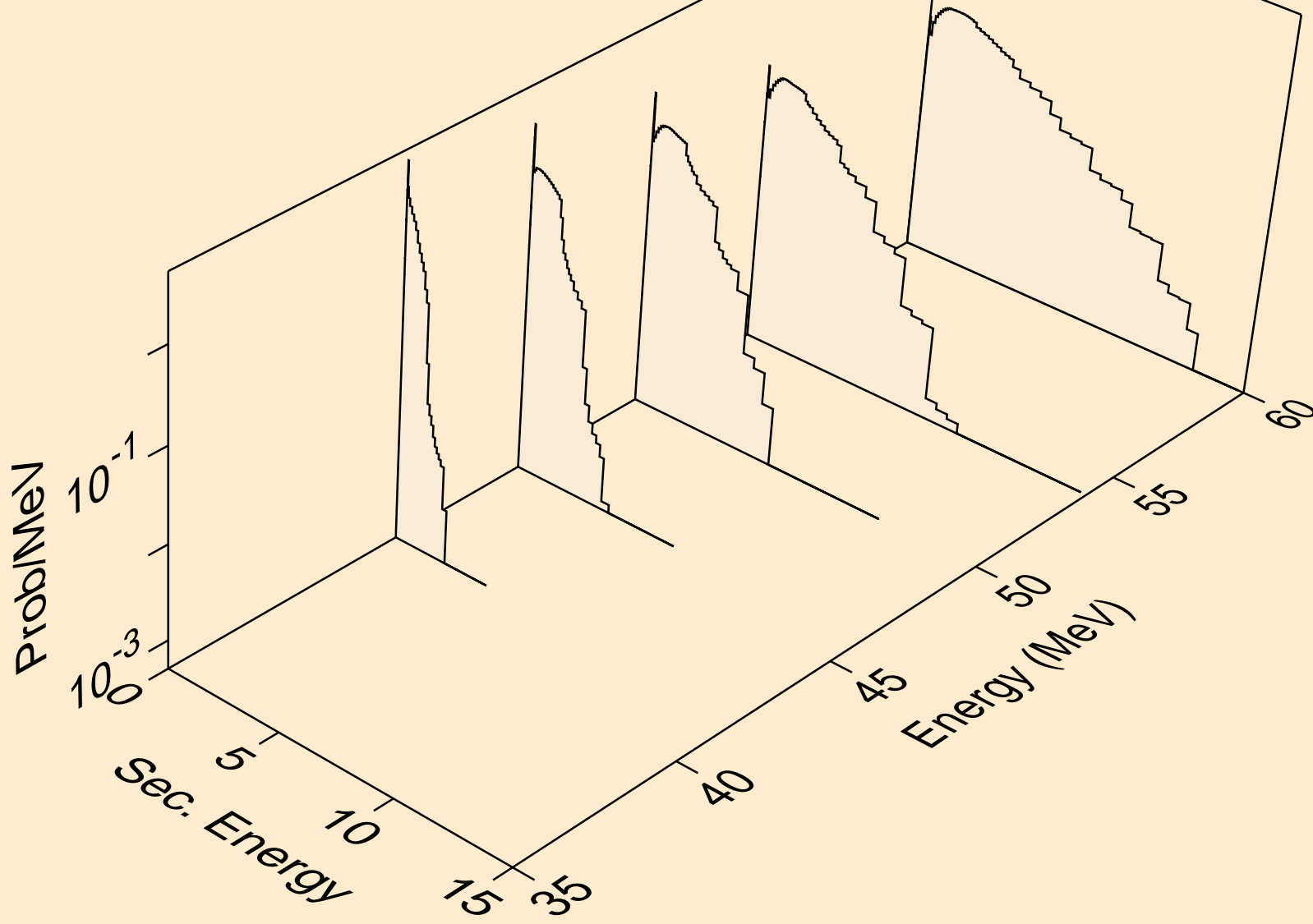

16-S-34 FOR FENDL-3.1 FROM TENDL-2010 WITH NJOY2012.50+
Neutron emission for (n,3n2pa)

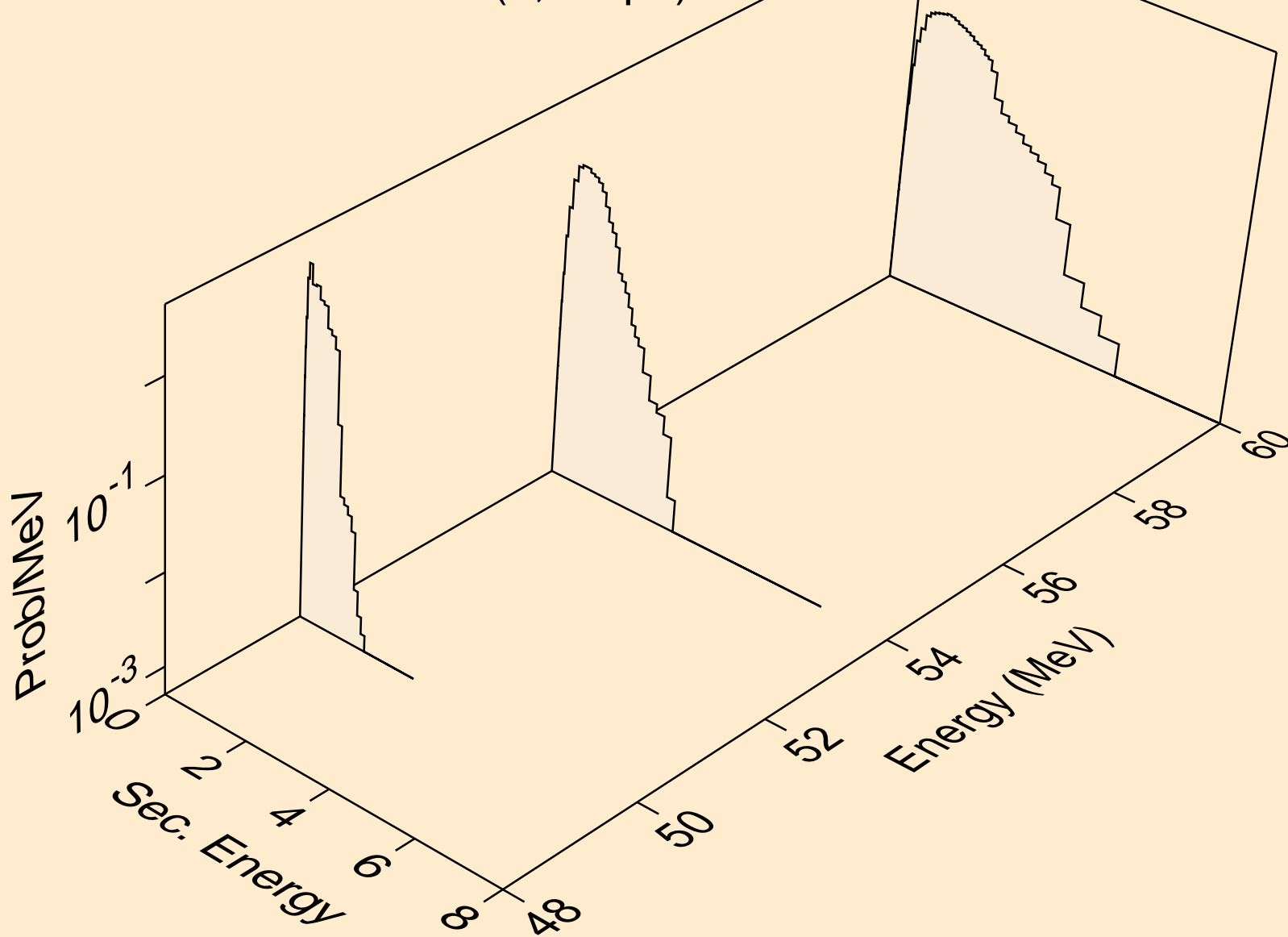

16-S-34 FOR FENDL-3.1 FROM TENDL-2010 WITH NJOY2012.50+
Photon emission for (n,x)

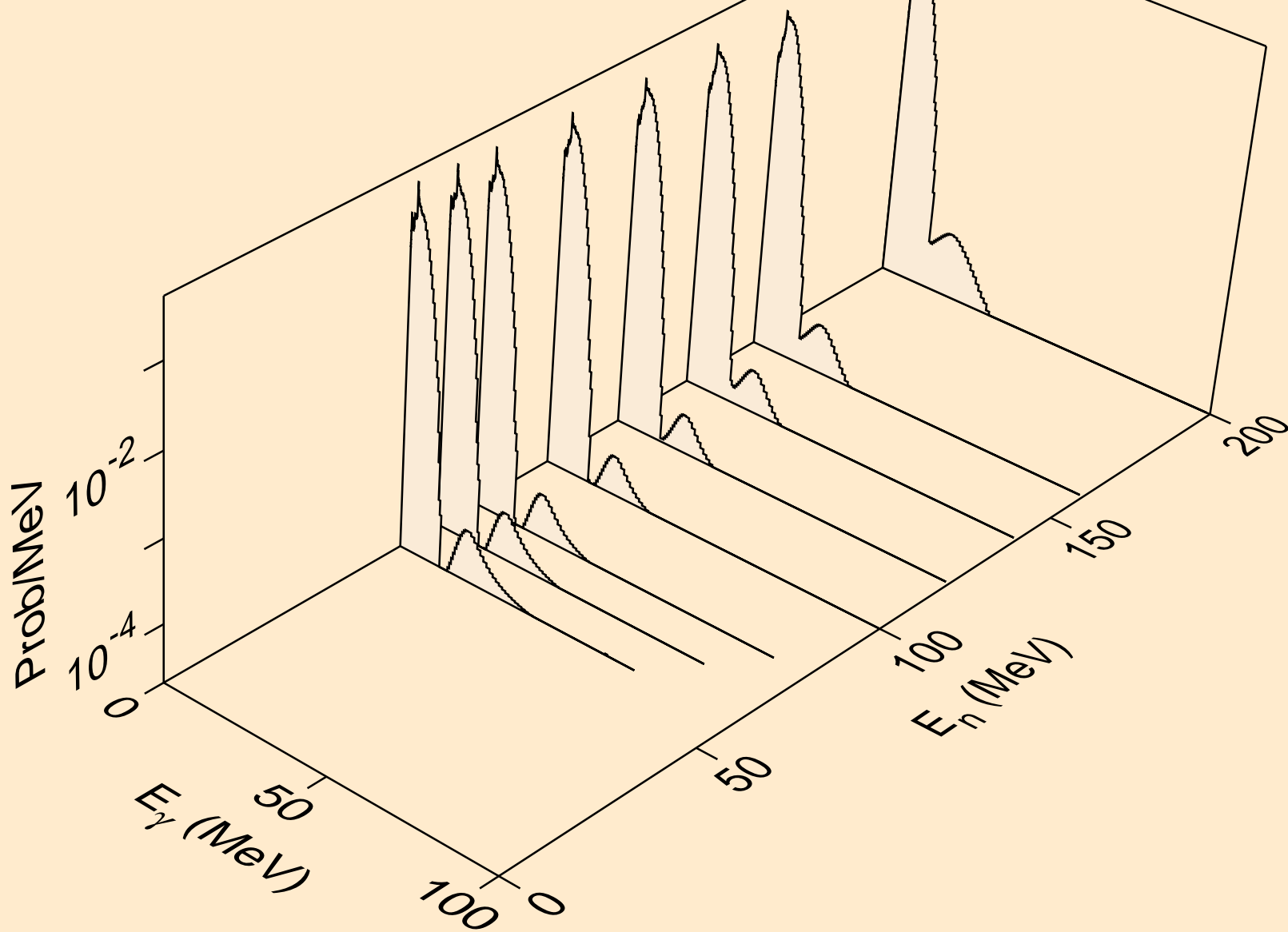

16-S-34 FOR FENDL-3.1 FROM TENDL-2010 WITH NJOY2012.50+
Photon emission for (n,2nd)

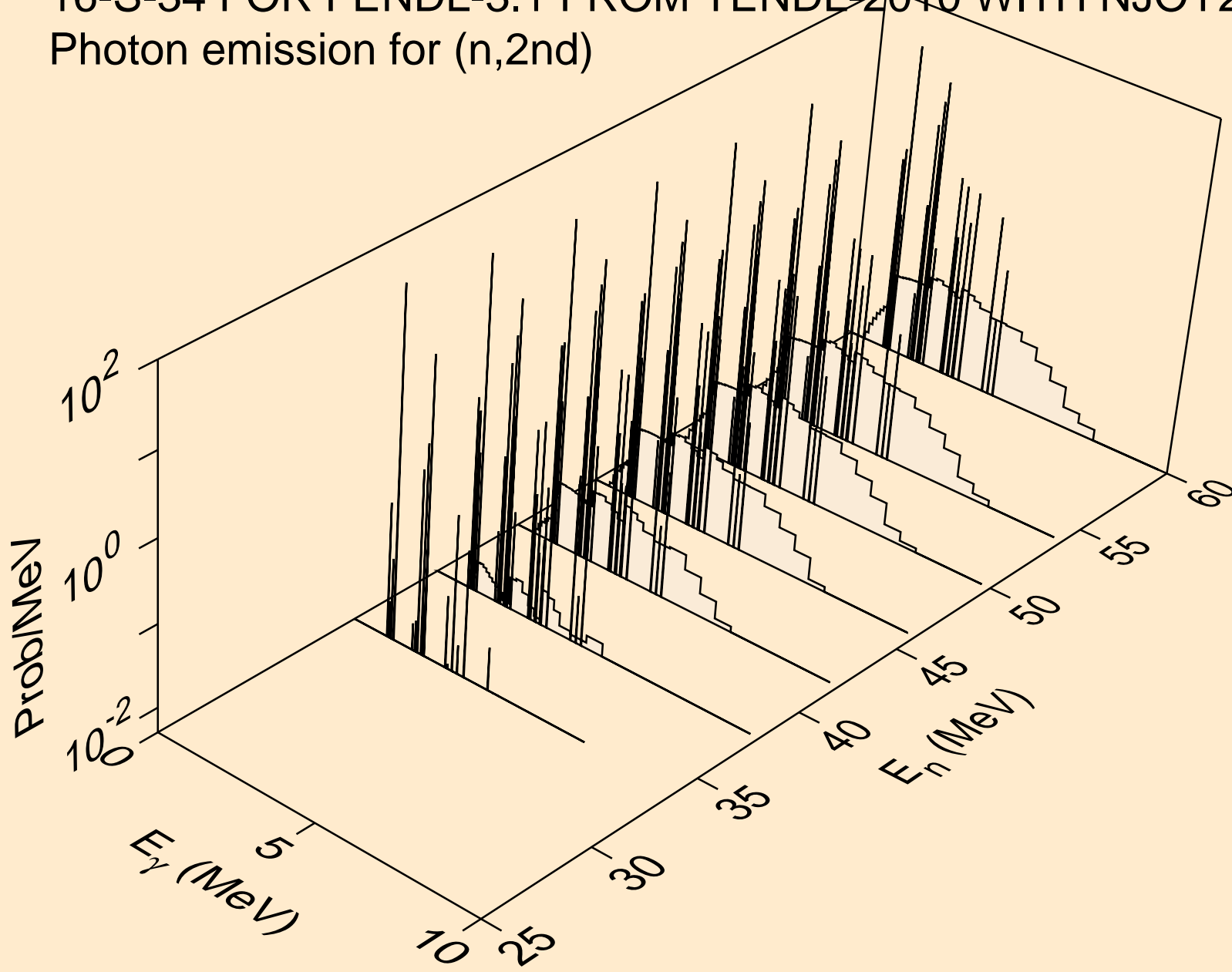

16-S-34 FOR FENDL-3.1 FROM TENDL-2010 WITH NJOY2012.50+
Photon emission for (n,2n)

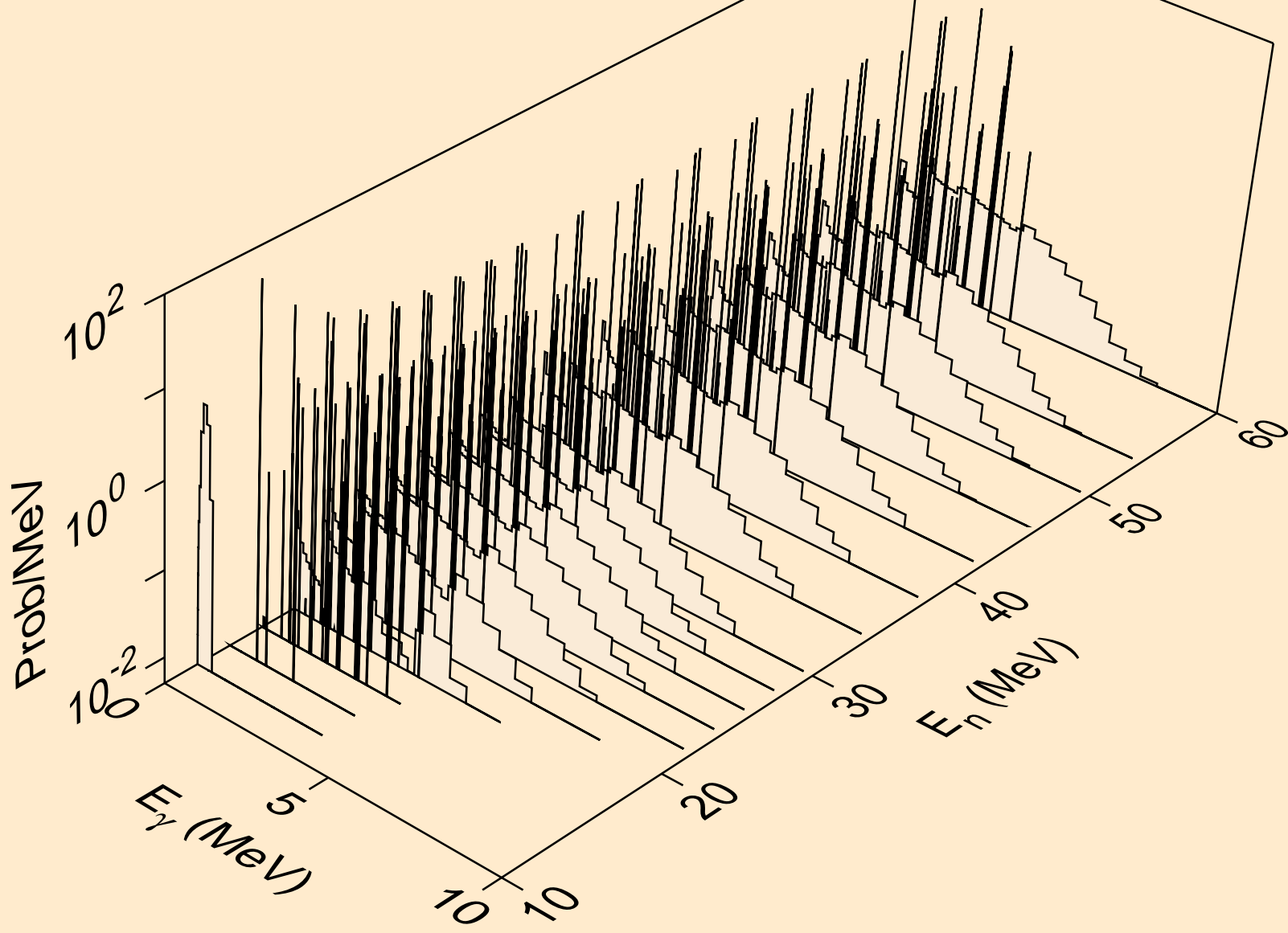

16-S-34 FOR FENDL-3.1 FROM TENDL-2010 WITH NJOY2012.50+
Photon emission for (n,3n)

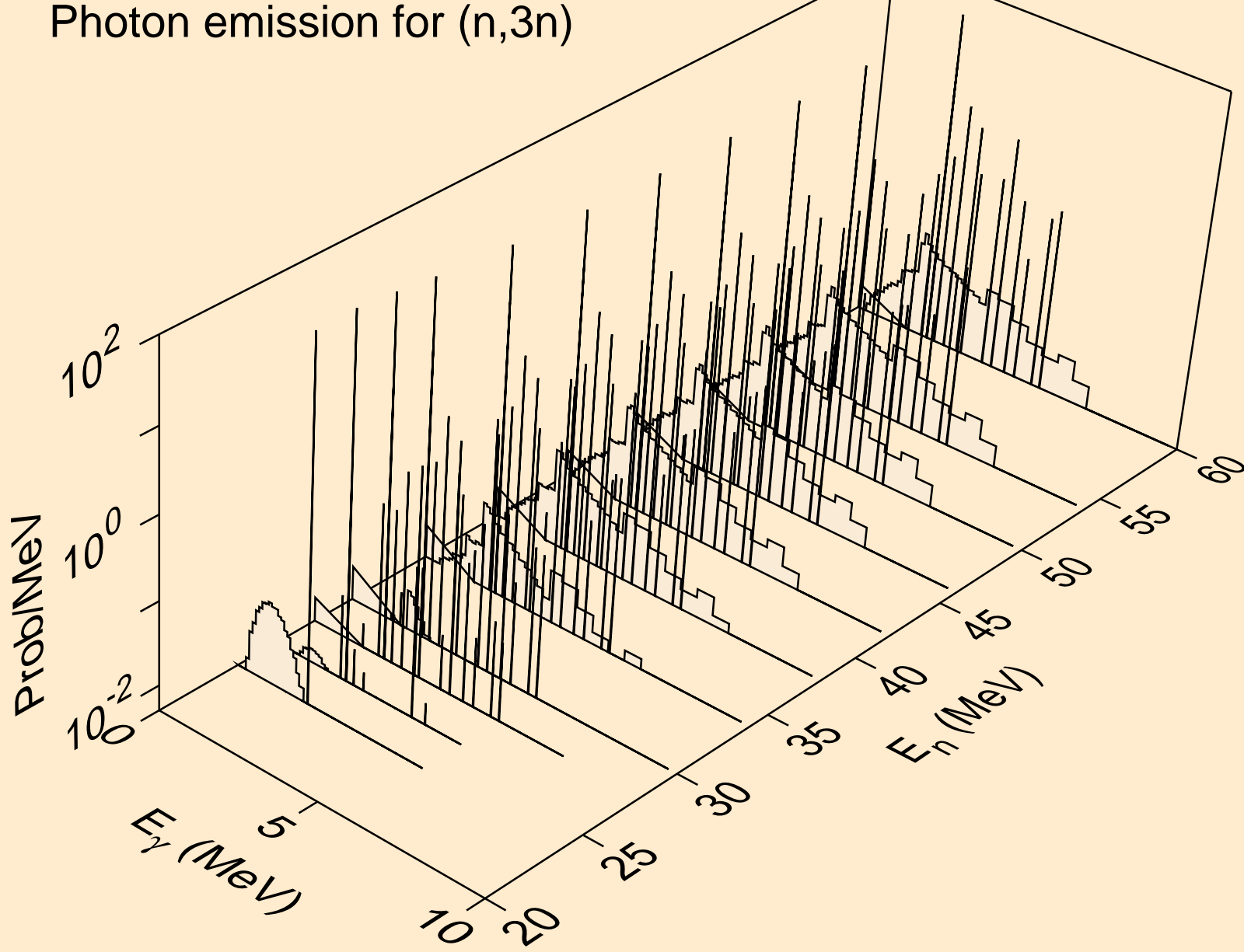

16-S-34 FOR FENDL-3.1 FROM TENDL-2010 WITH NJOY2012.50+
Photon emission for (n,n*)a

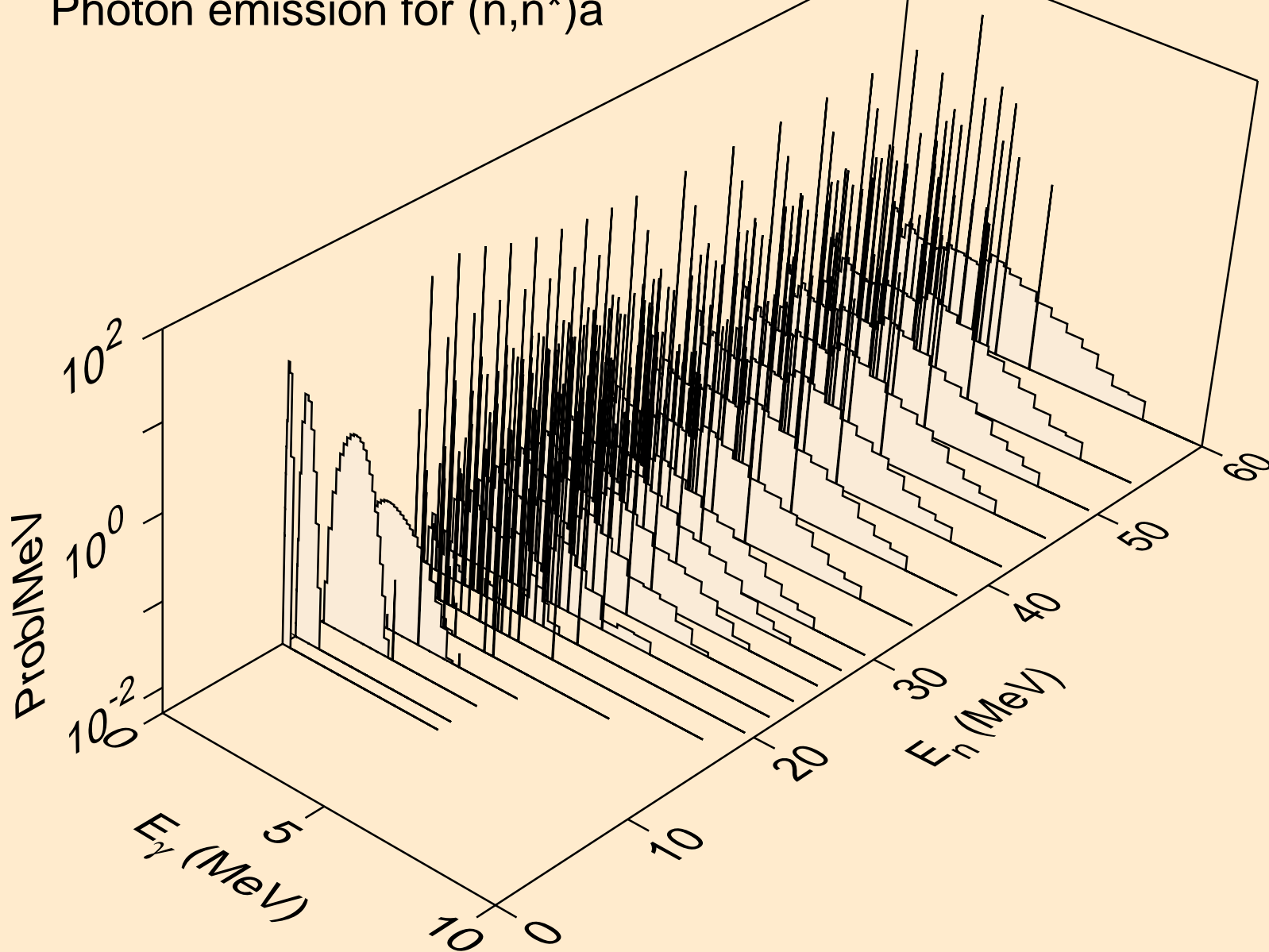

16-S-34 FOR FENDL-3.1 FROM TENDL-2010 WITH NJOY2012.50+
Photon emission for (n,n*)3a

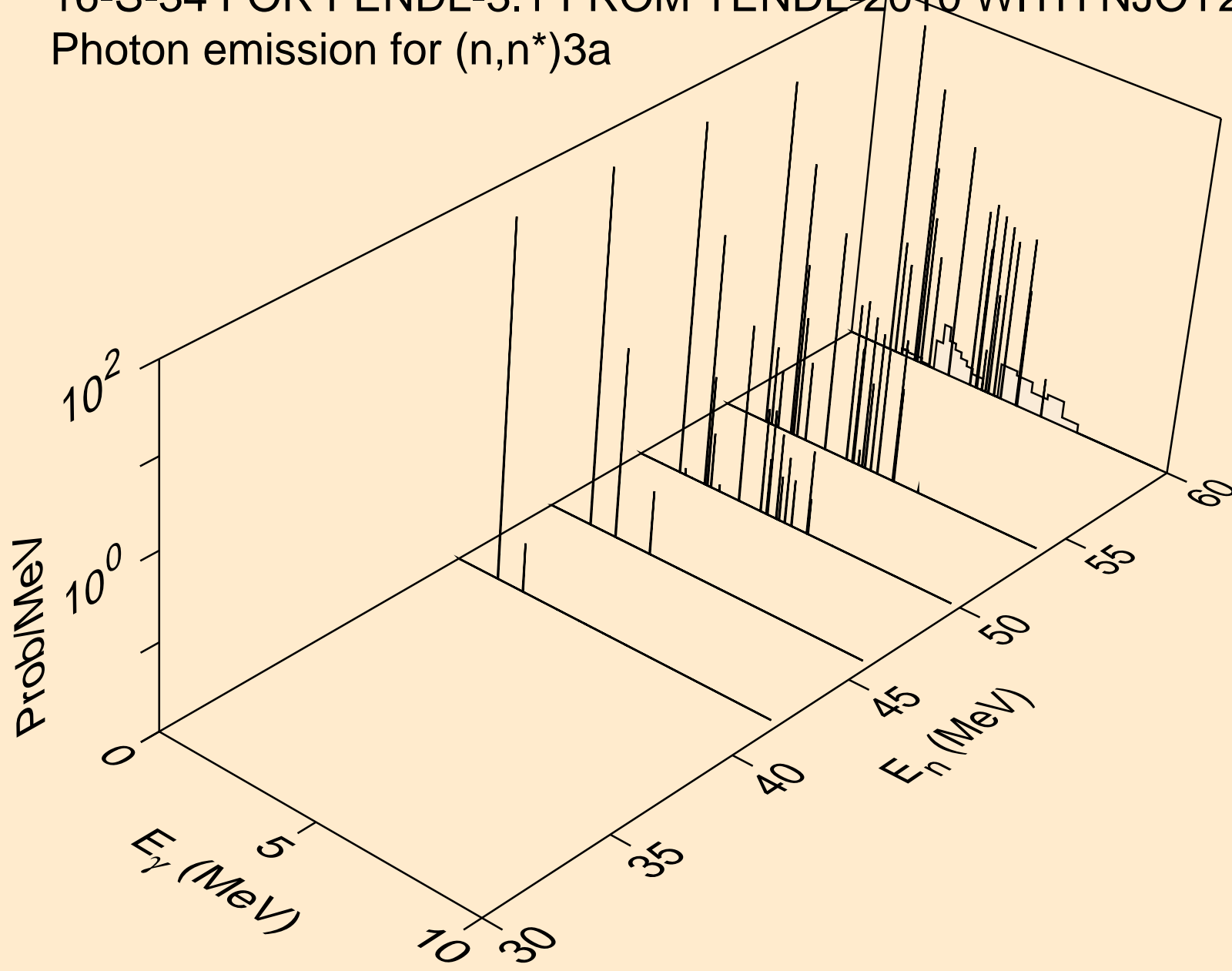

16-S-34 FOR FENDL-3.1 FROM TENDL-2010 WITH NJOY2012.50+
Photon emission for (n,2n)a

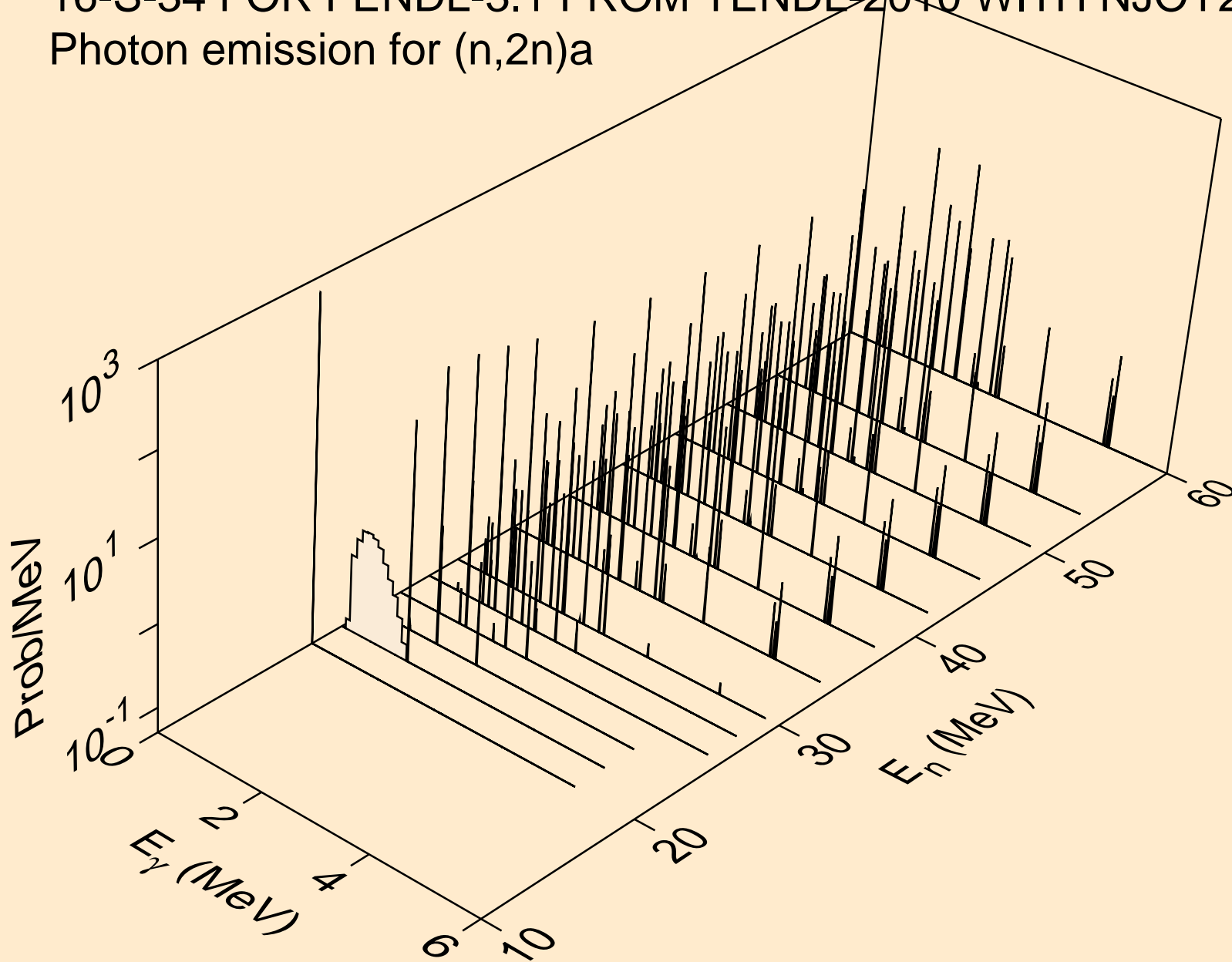

16-S-34 FOR FENDL-3.1 FROM TENDL-2010 WITH NJOY2012.50+
Photon emission for (n,3n)a

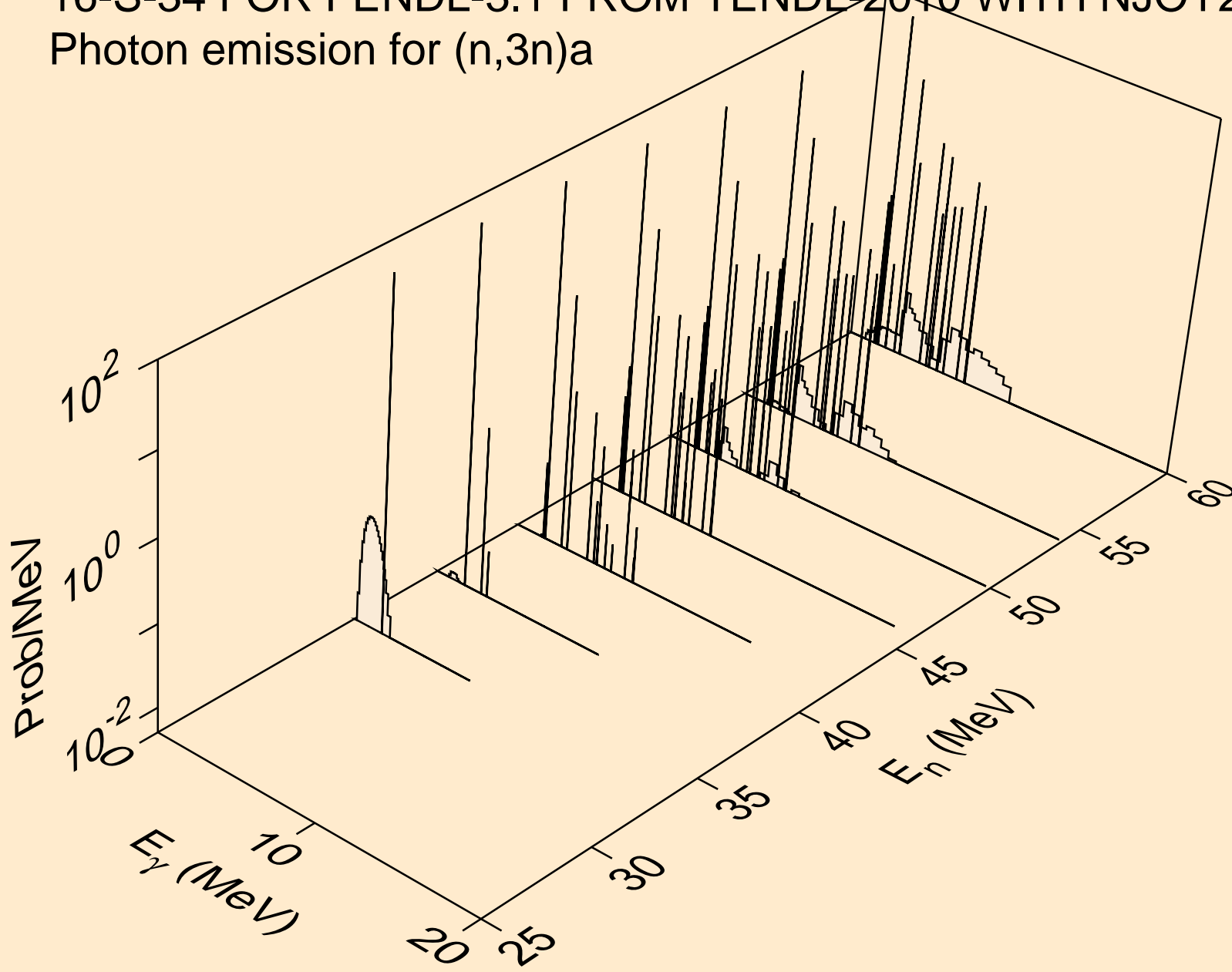

16-S-34 FOR FENDL-3.1 FROM TENDL-2010 WITH NJOY2012.50+
Photon emission for (n,n*)p

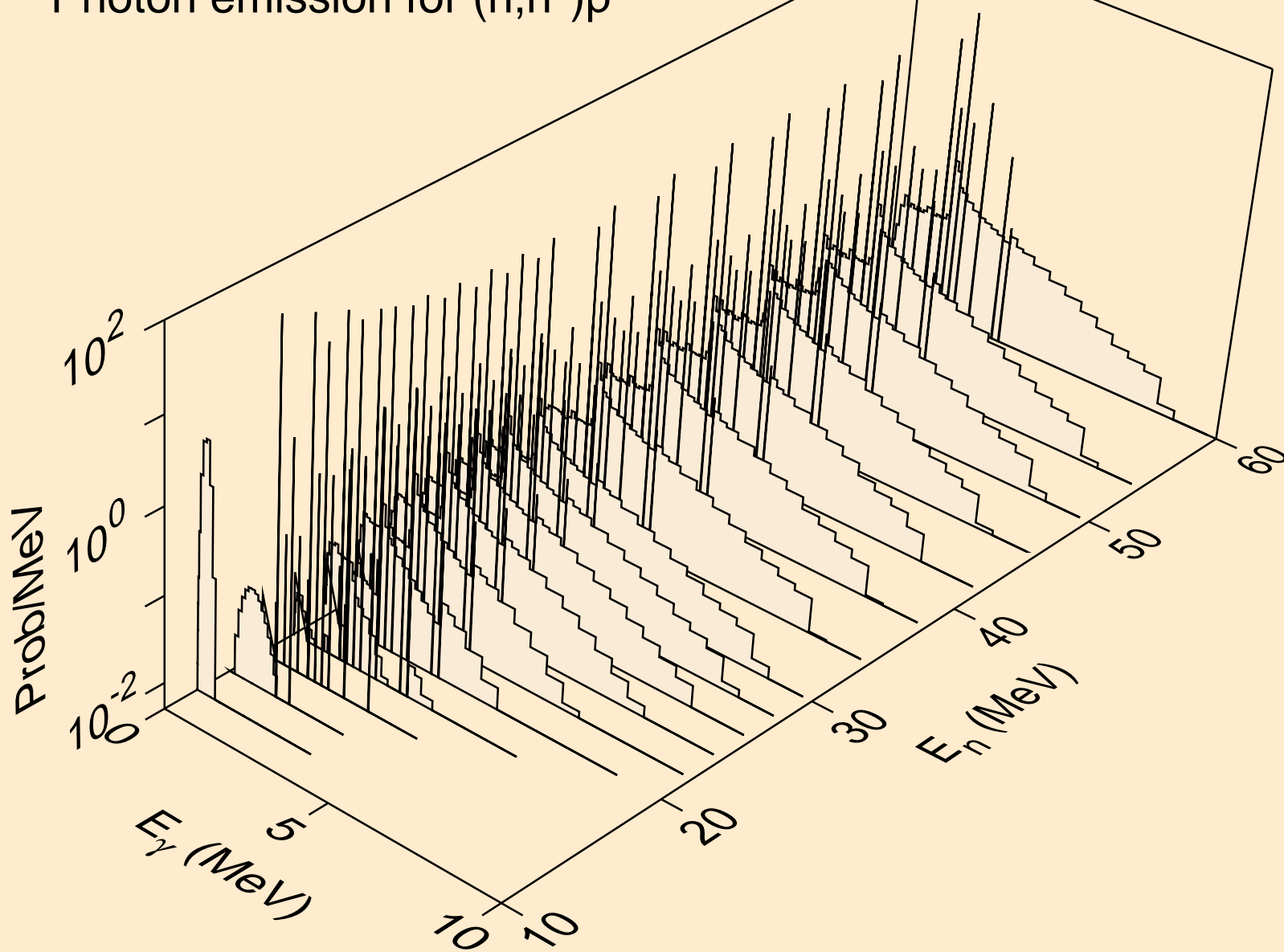

16-S-34 FOR FENDL-3.1 FROM TENDL-2010 WITH NJOY2012.50+
Photon emission for (n,n*)2a

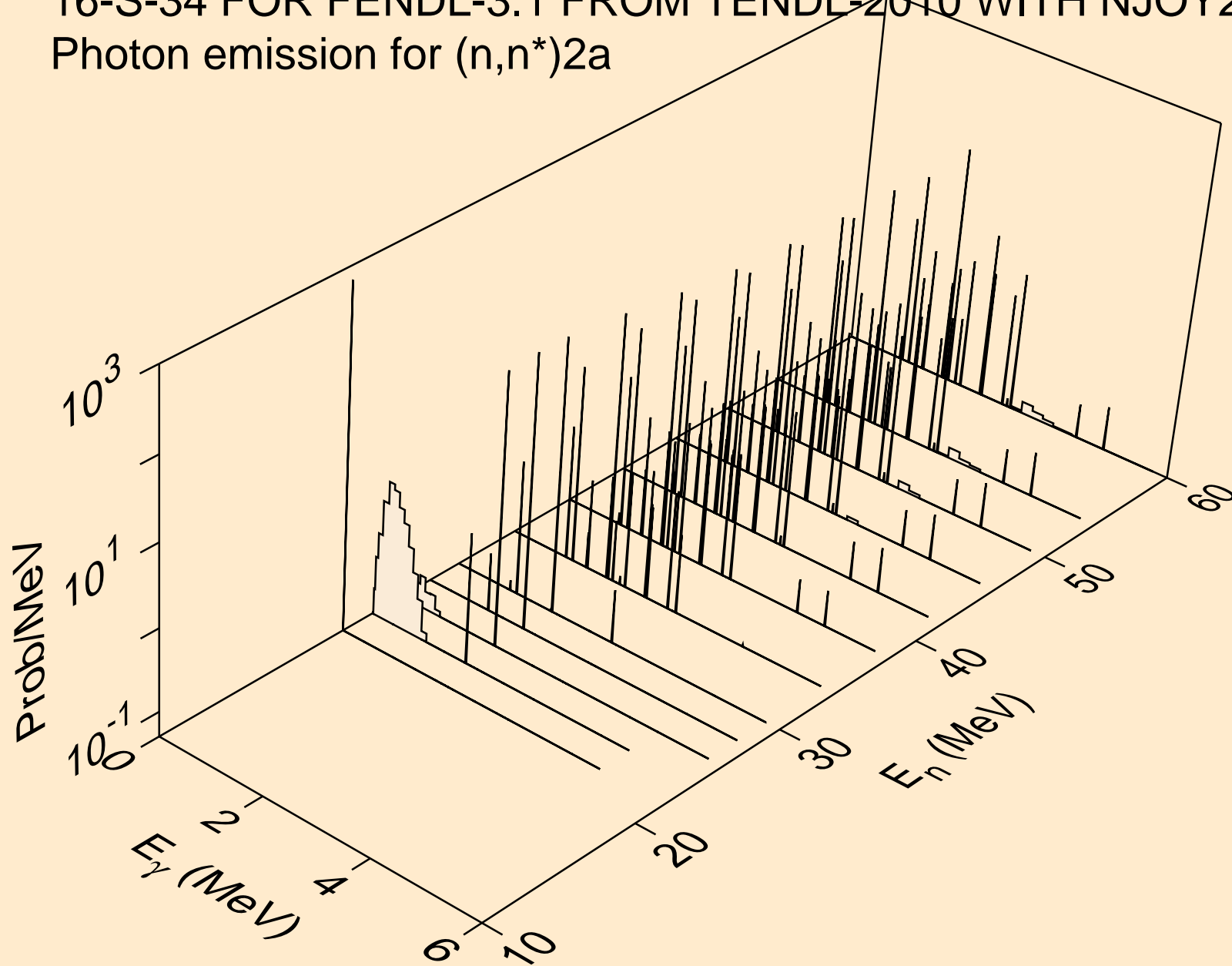

16-S-34 FOR FENDL-3.1 FROM TENDL-2010 WITH NJOY2012.50+
Photon emission for (n,2n)2a

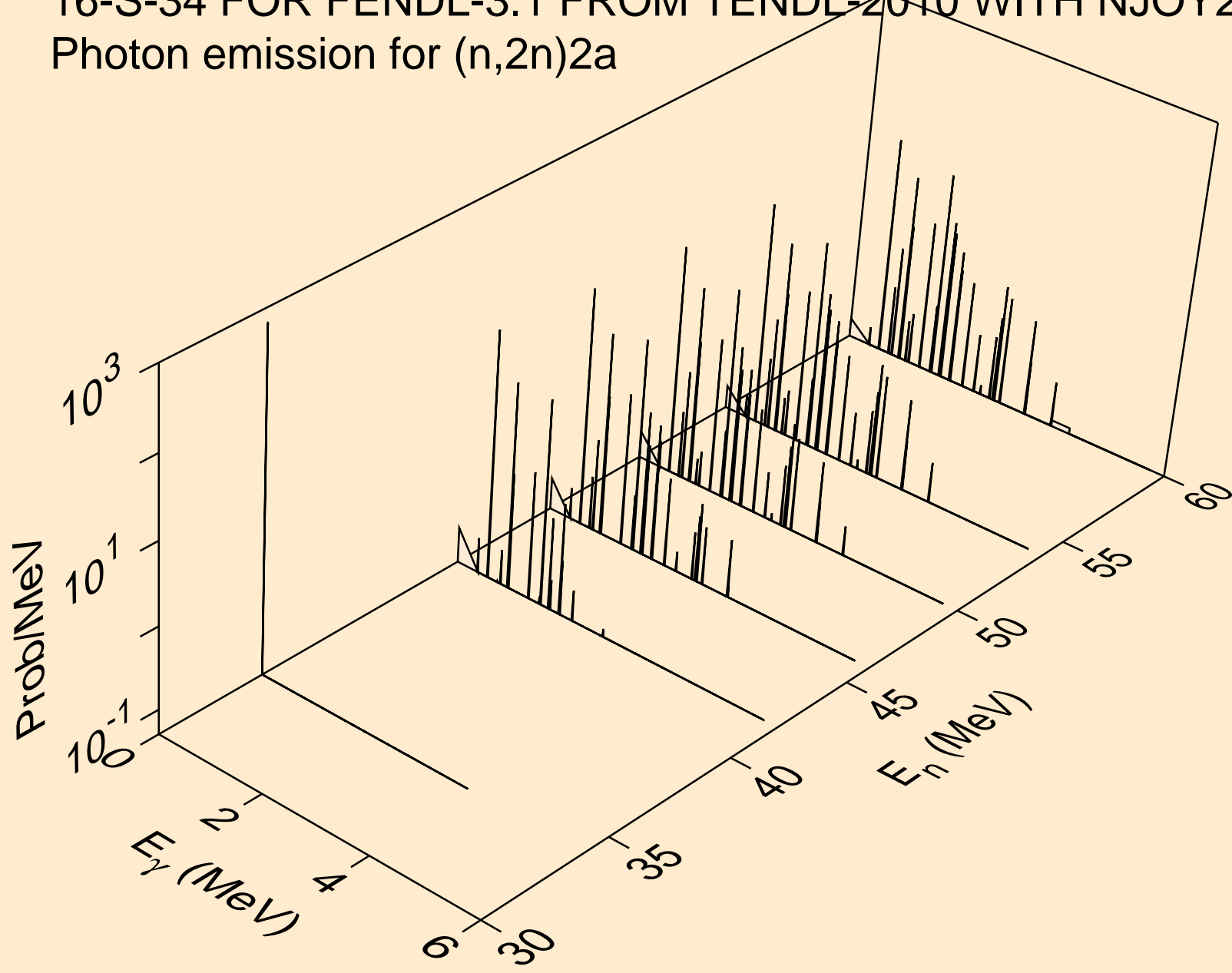

16-S-34 FOR FENDL-3.1 FROM TENDL-2010 WITH NJOY2012.50+
Photon emission for (n,n*)d

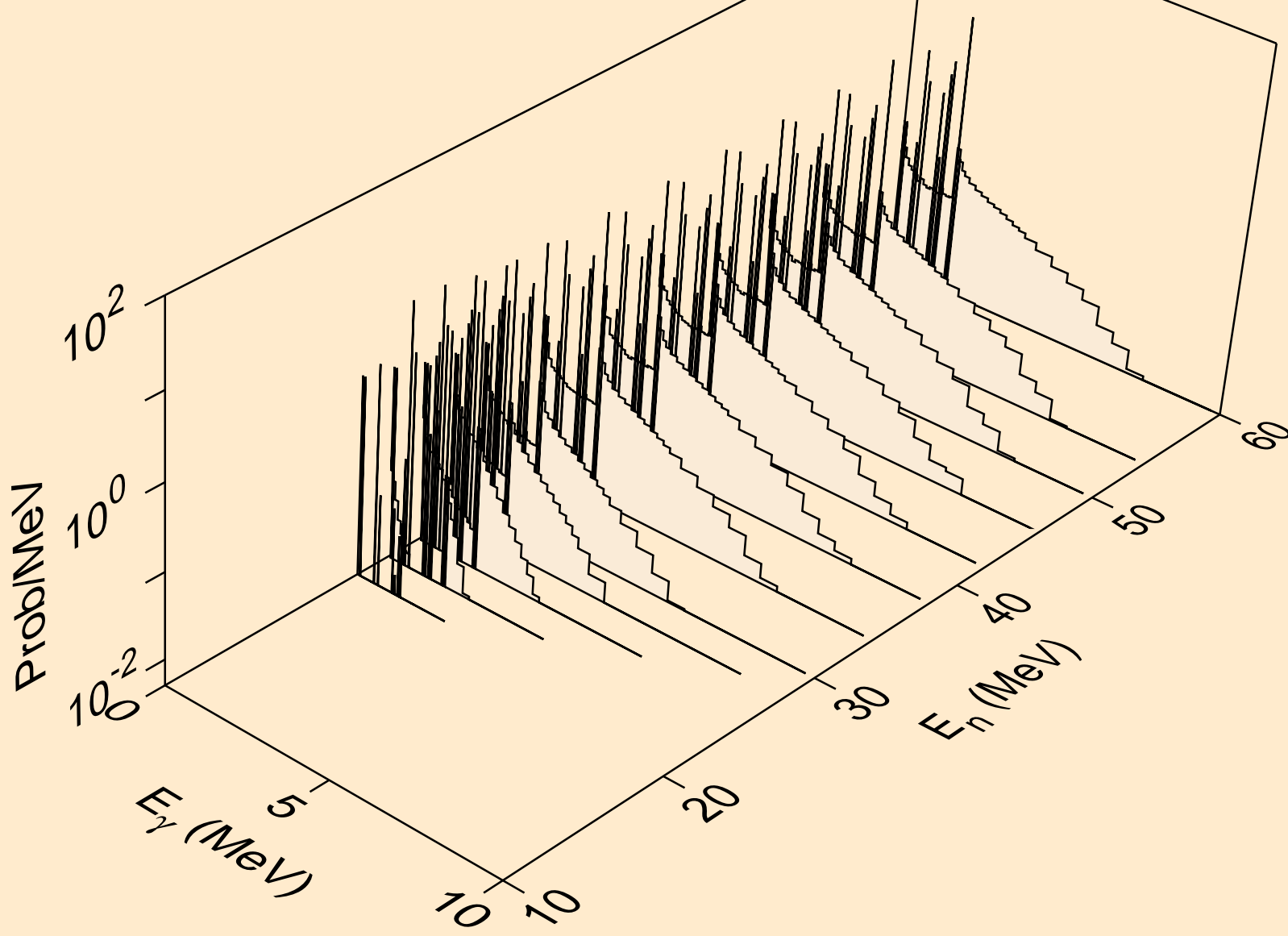

16-S-34 FOR FENDL-3.1 FROM TENDL-2010 WITH NJOY2012.50+
Photon emission for (n,n*)t

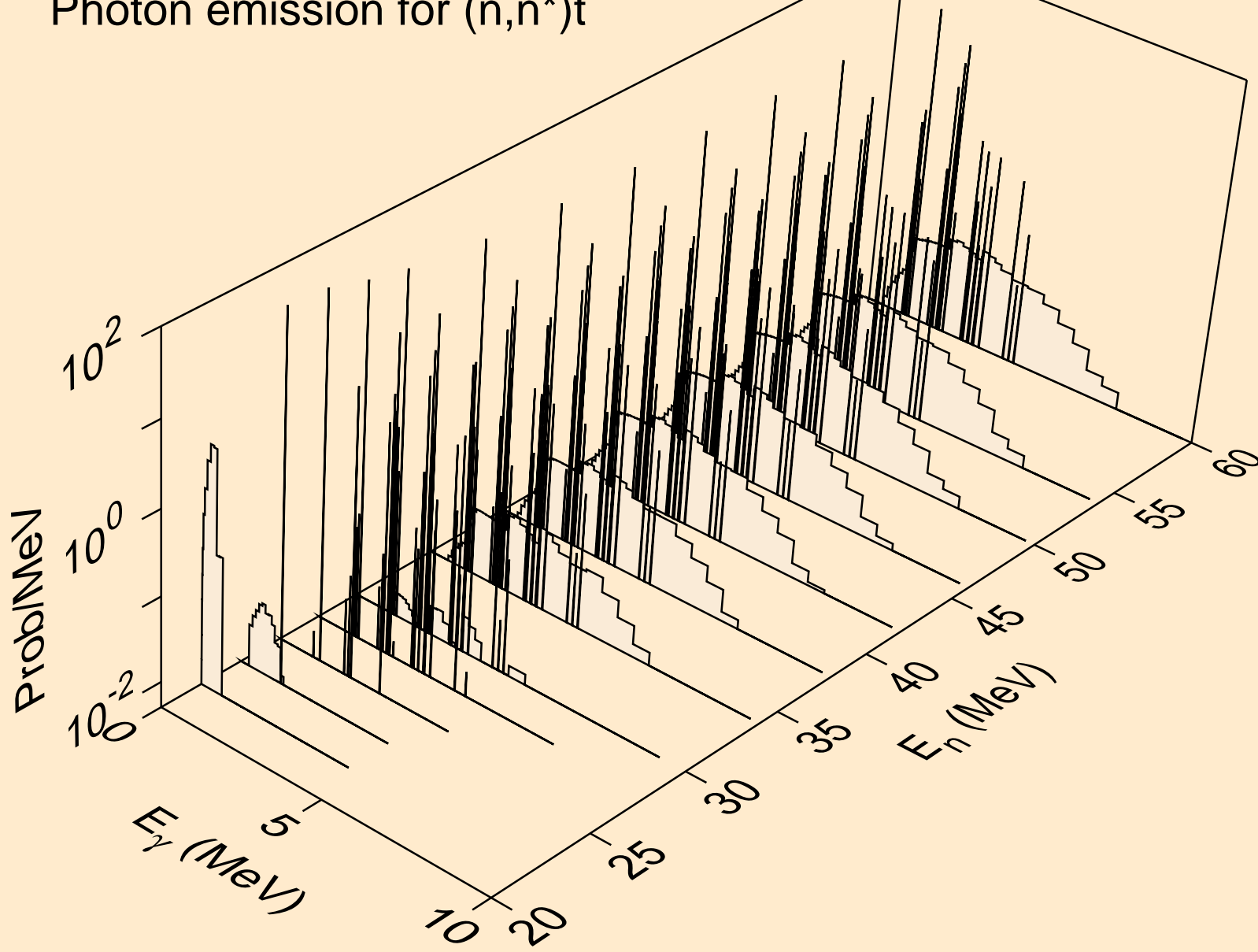

16-S-34 FOR FENDL-3.1 FROM TENDL-2010 WITH NJOY2012.50+
Photon emission for (n,n*)he3

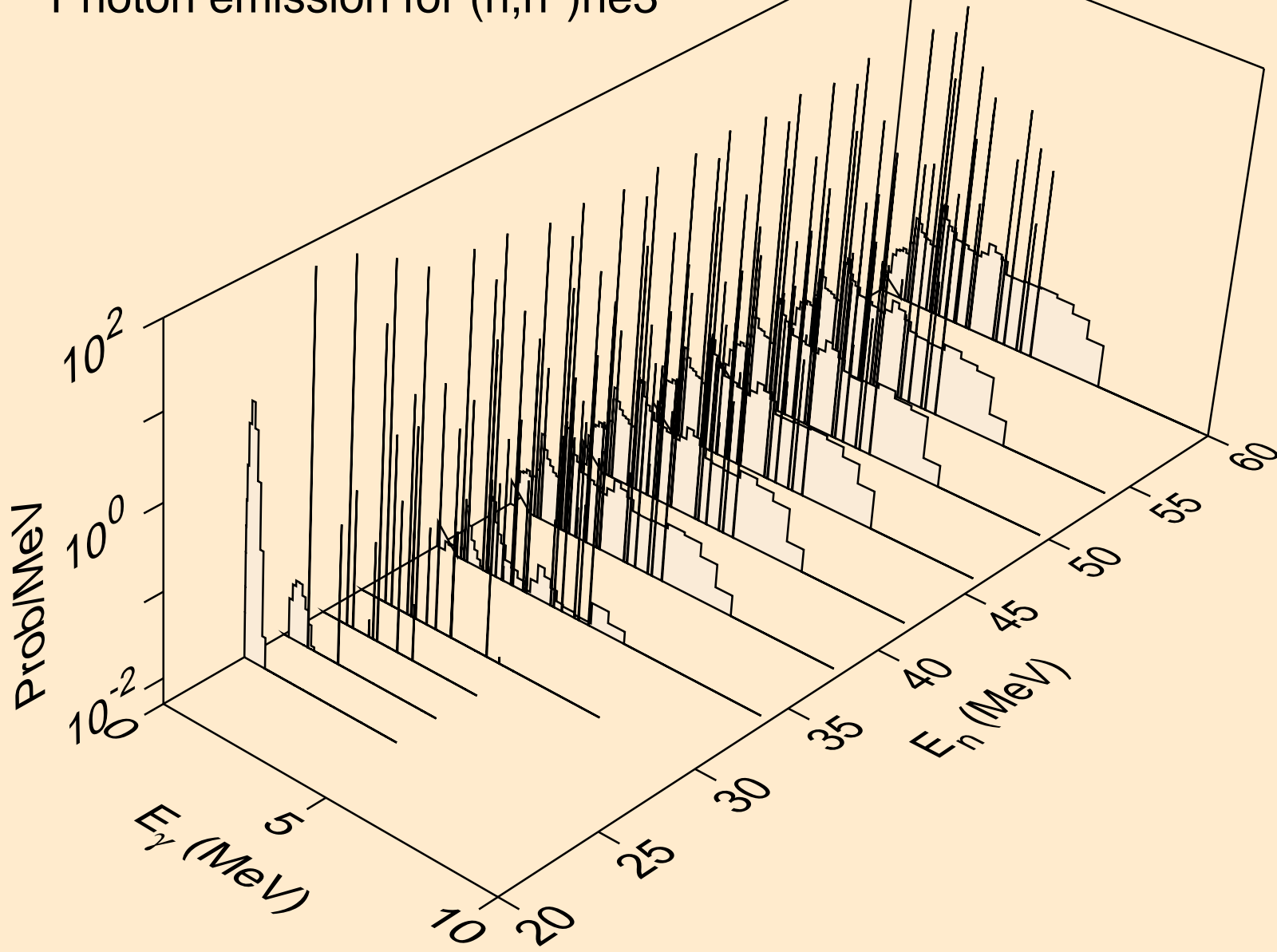

16-S-34 FOR FENDL-3.1 FROM TENDL-2010 WITH NJOY2012.50+
Photon emission for (n,n*)d2a

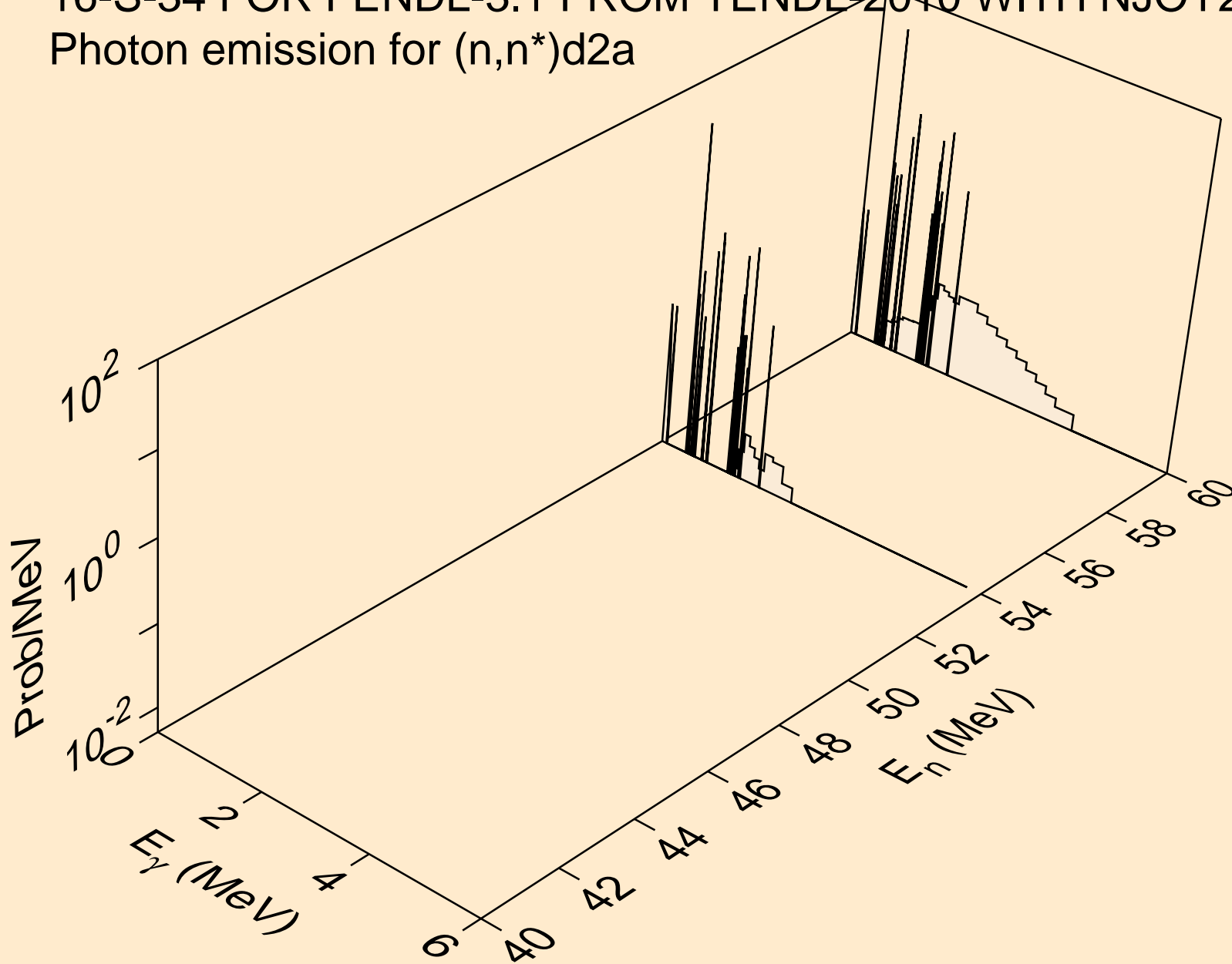

16-S-34 FOR FENDL-3.1 FROM TENDL-2010 WITH NJOY2012.50+
Photon emission for (n,n*)t2a

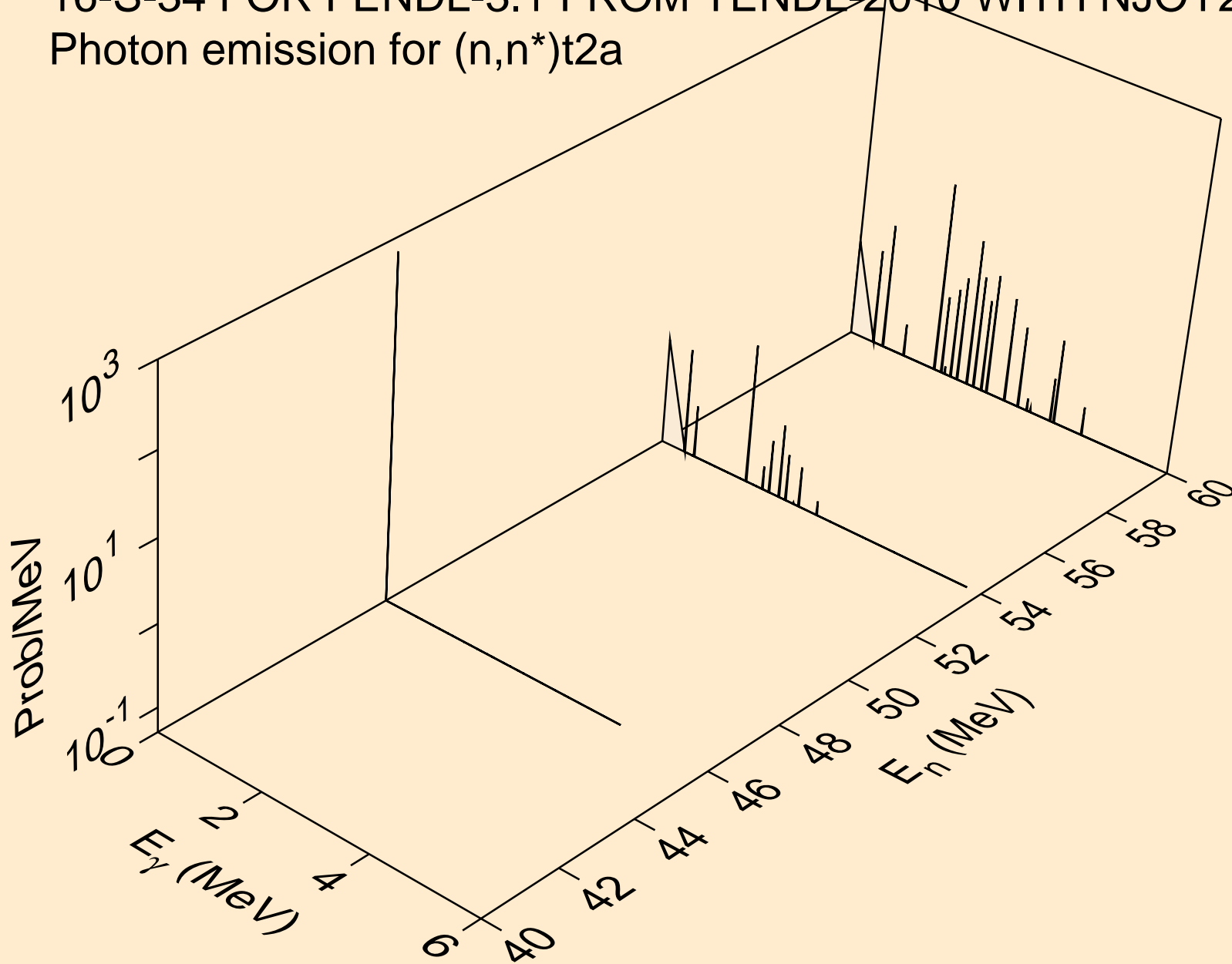

16-S-34 FOR FENDL-3.1 FROM TENDL-2010 WITH NJOY2012.50+
Photon emission for (n,4n)

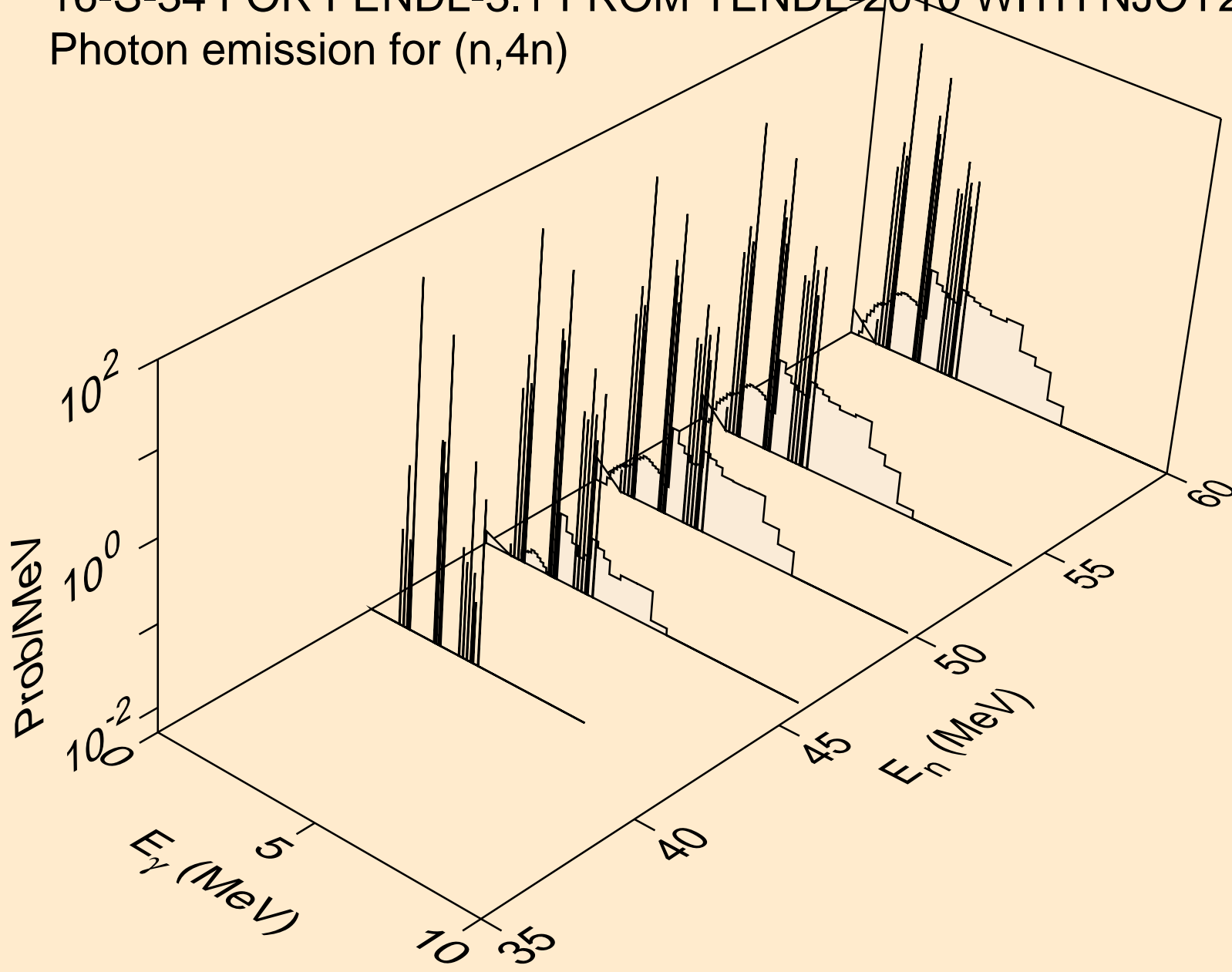

16-S-34 FOR FENDL-3.1 FROM TENDL-2010 WITH NJOY2012.50+
Photon emission for (n,2np)

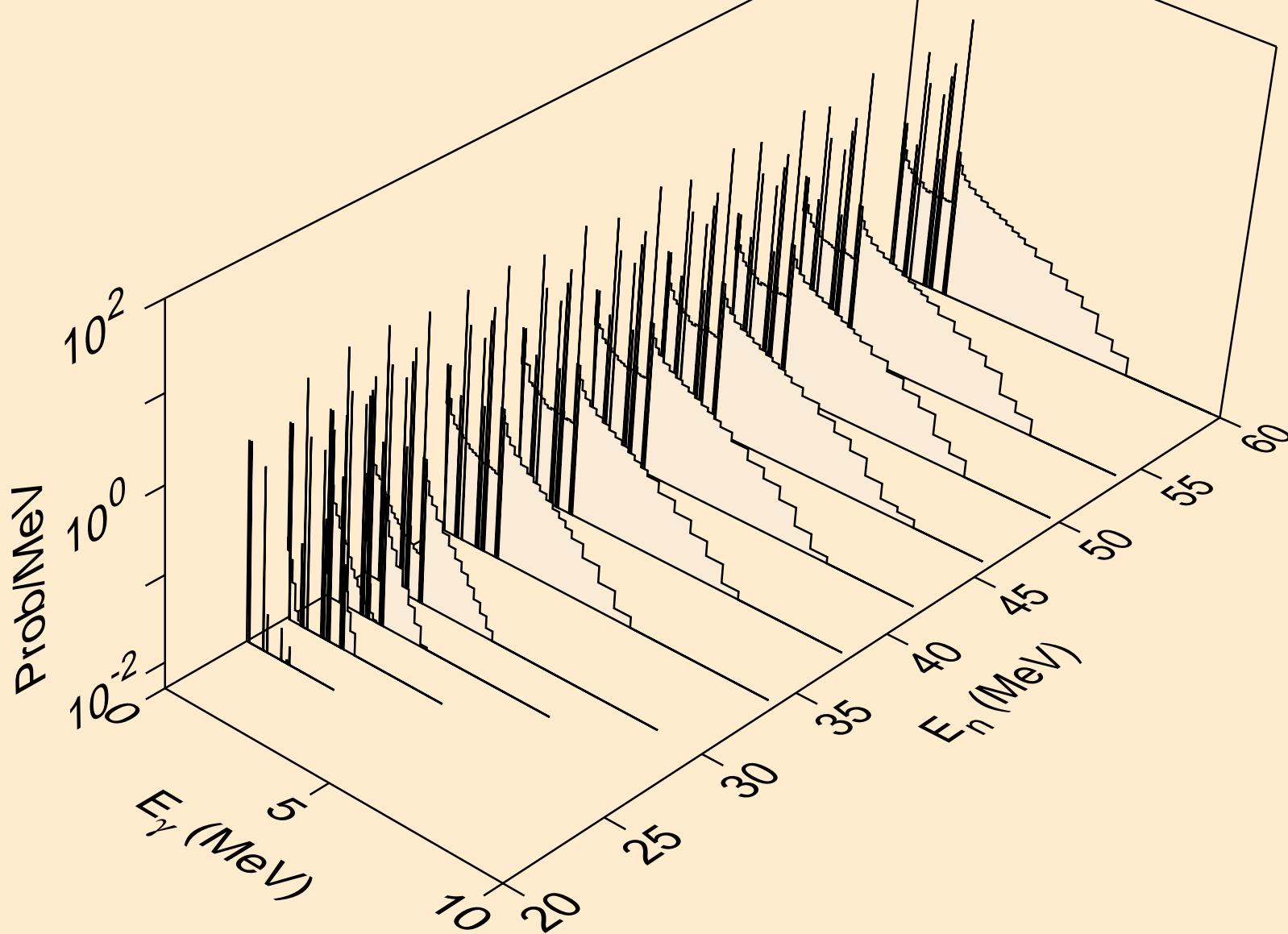

16-S-34 FOR FENDL-3.1 FROM TENDL-2010 WITH NJOY2012.50+
Photon emission for (n,3np)

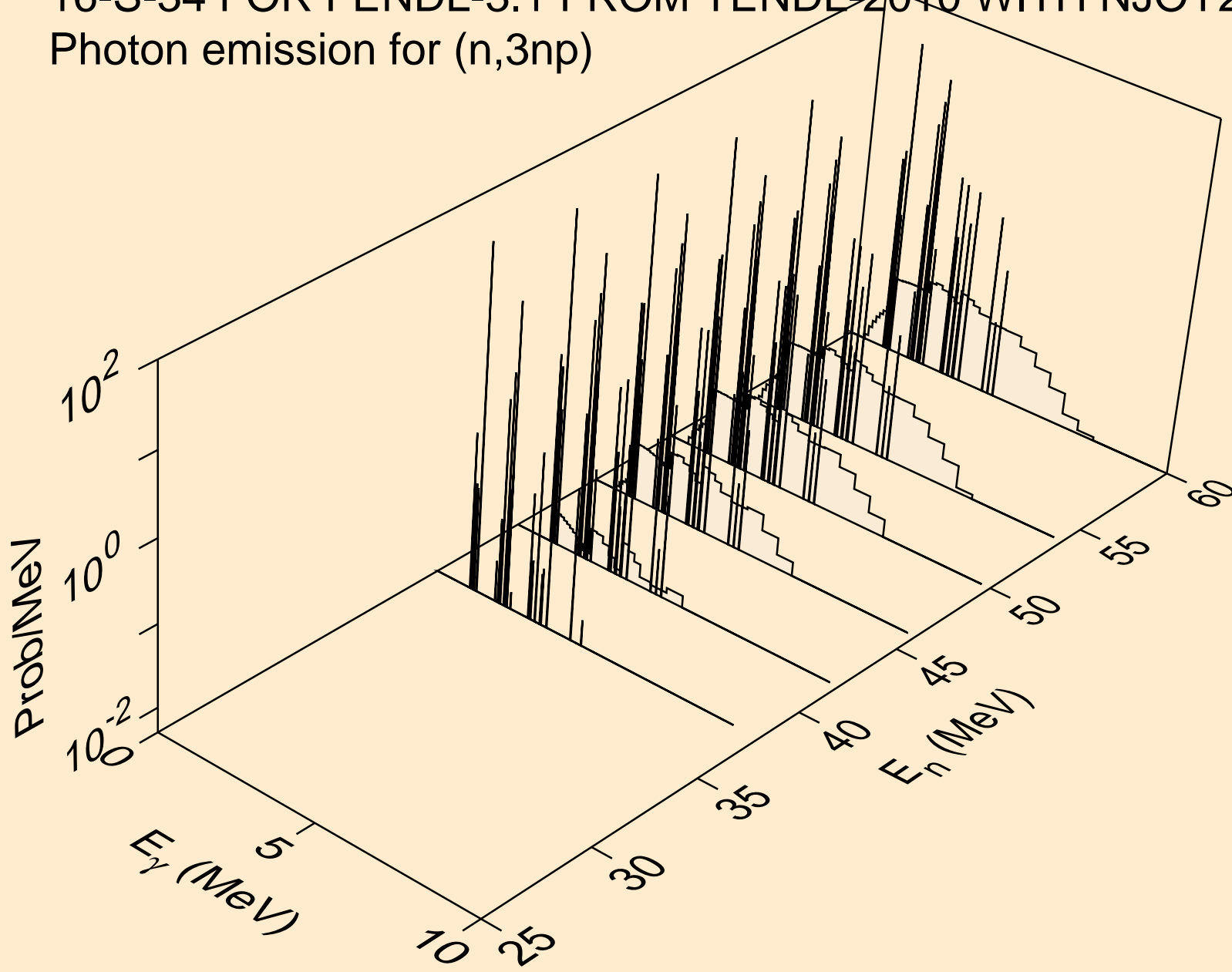

16-S-34 FOR FENDL-3.1 FROM TENDL-2010 WITH NJOY2012.50+
Photon emission for (n,2np)

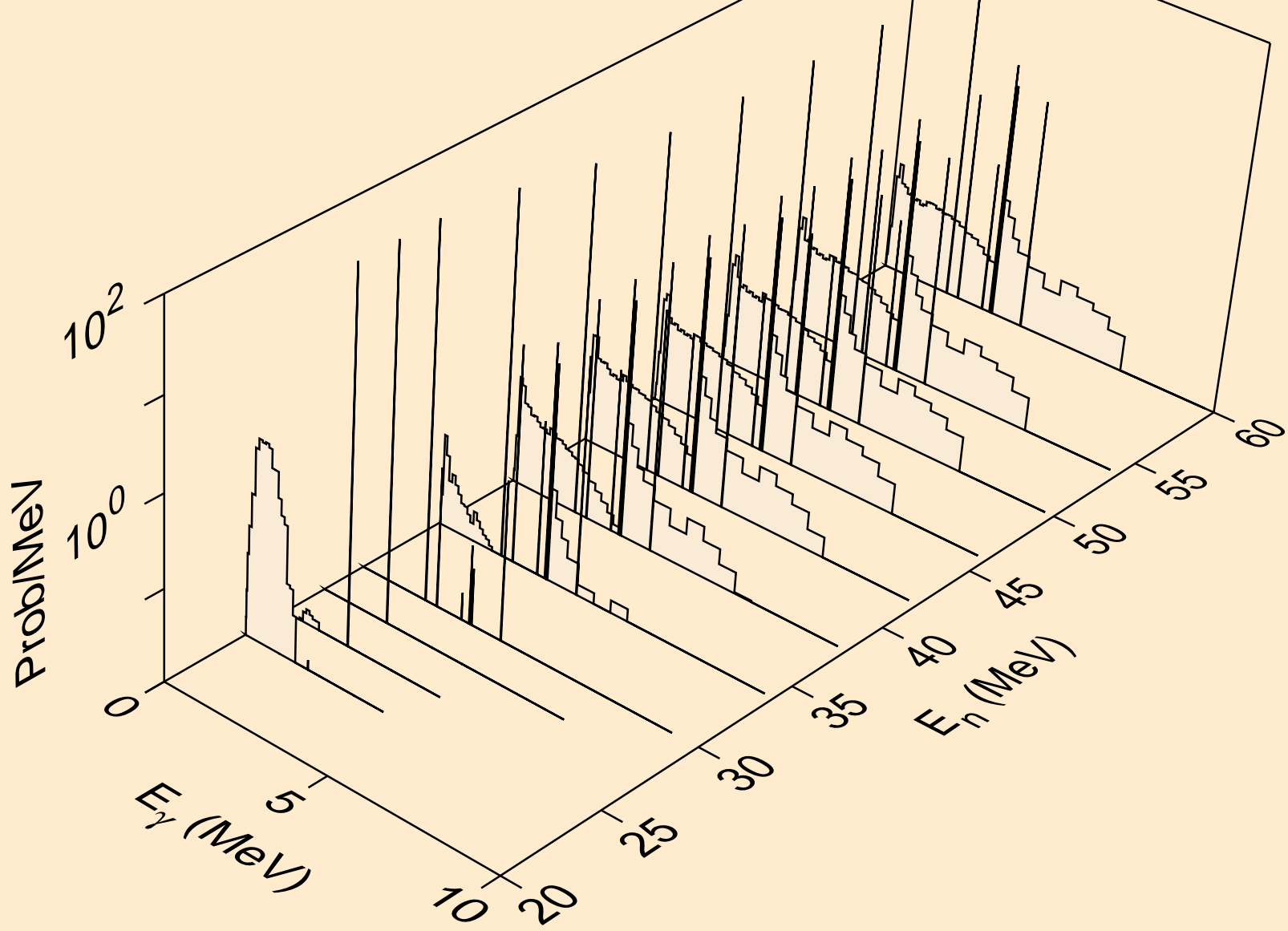

16-S-34 FOR FENDL-3.1 FROM TENDL-2010 WITH NJOY2012.50+
Photon emission for (n,npa)

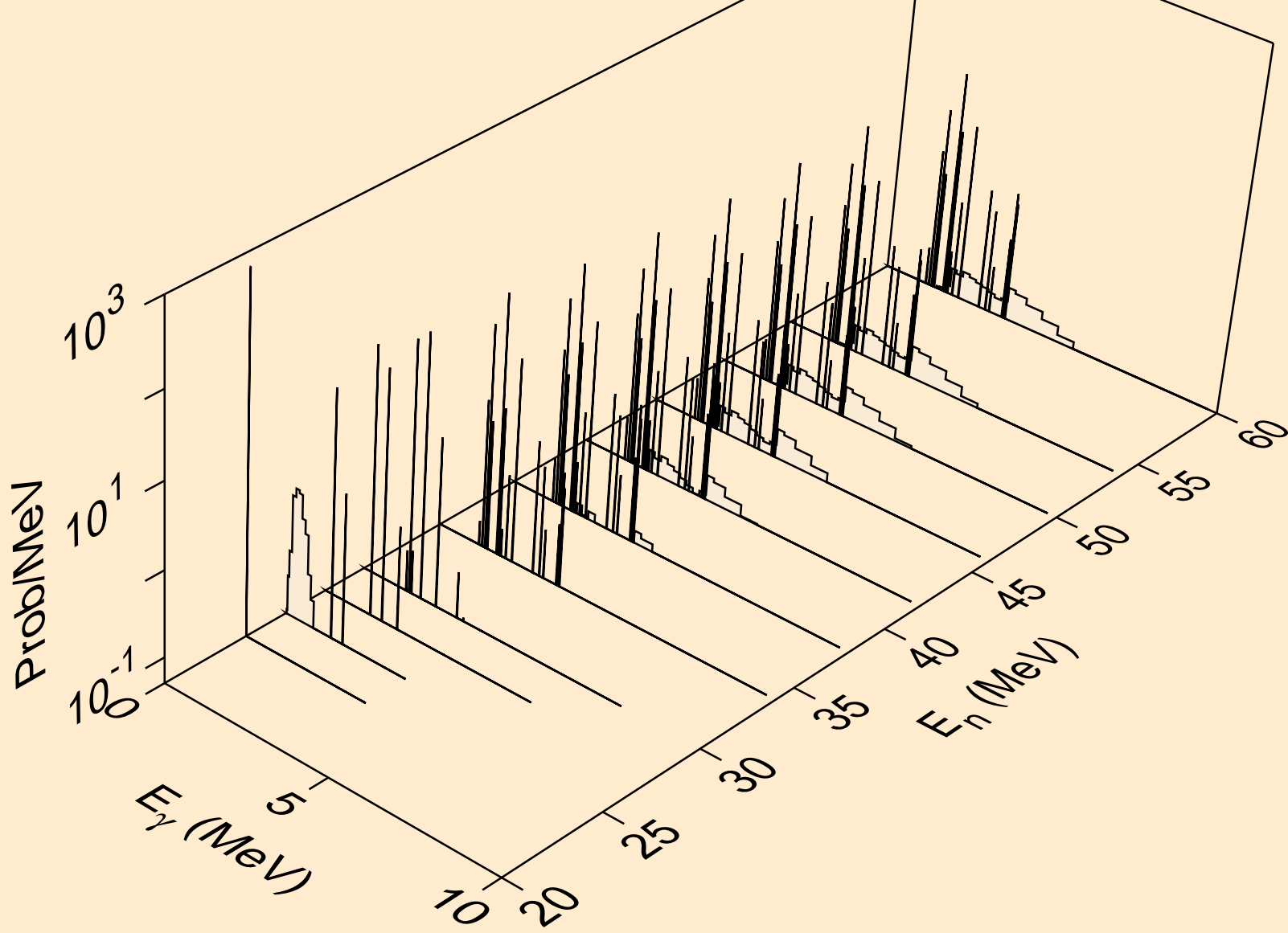

16-S-34 FOR FENDL-3.1 FROM TENDL-2010 WITH NJOY2012.50+
Photon emission for (n,n*c)

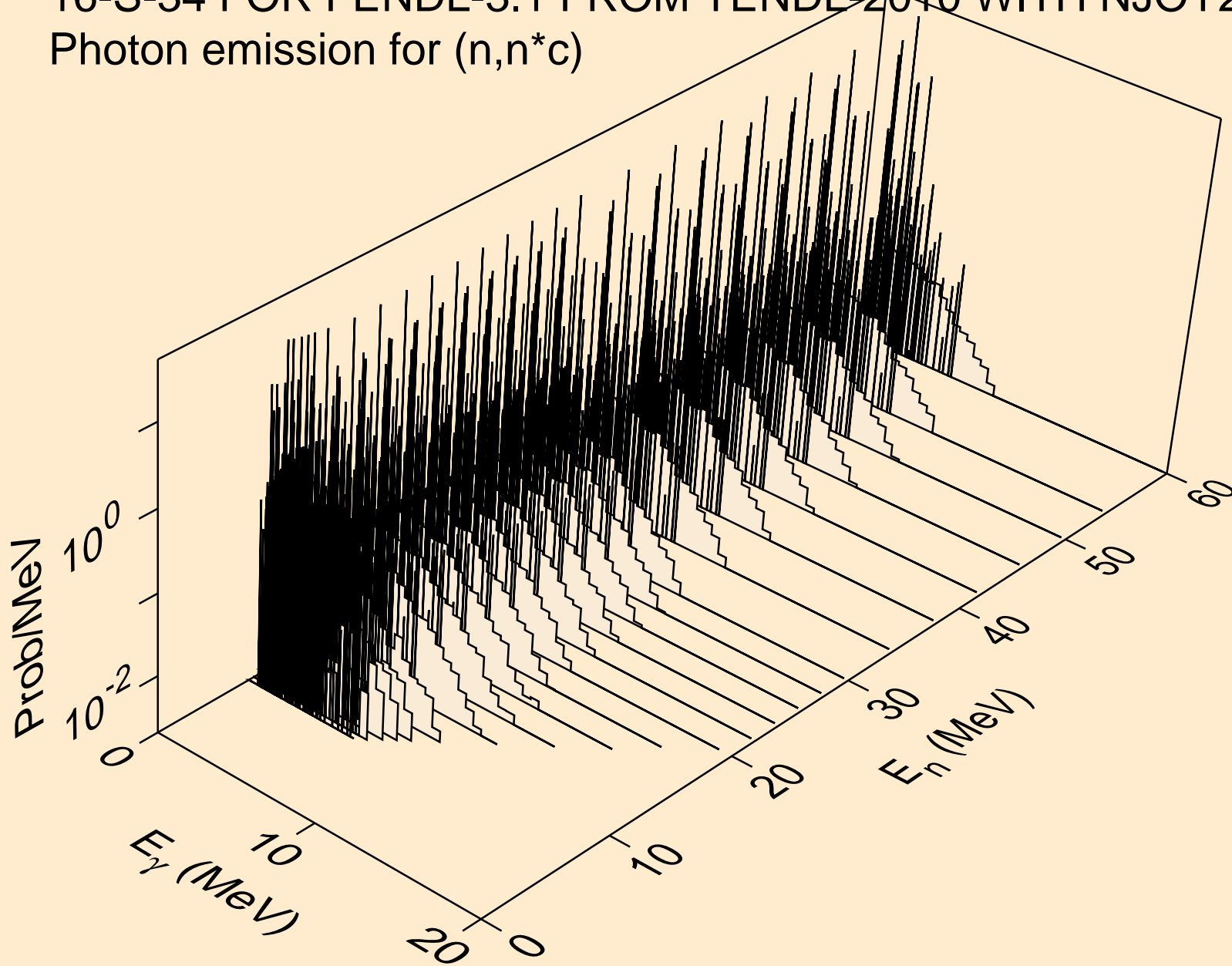

16-S-34 FOR FENDL-3.1 FROM TENDL-2010 WITH NJOY2012.50+
Photon emission for (n,gma)

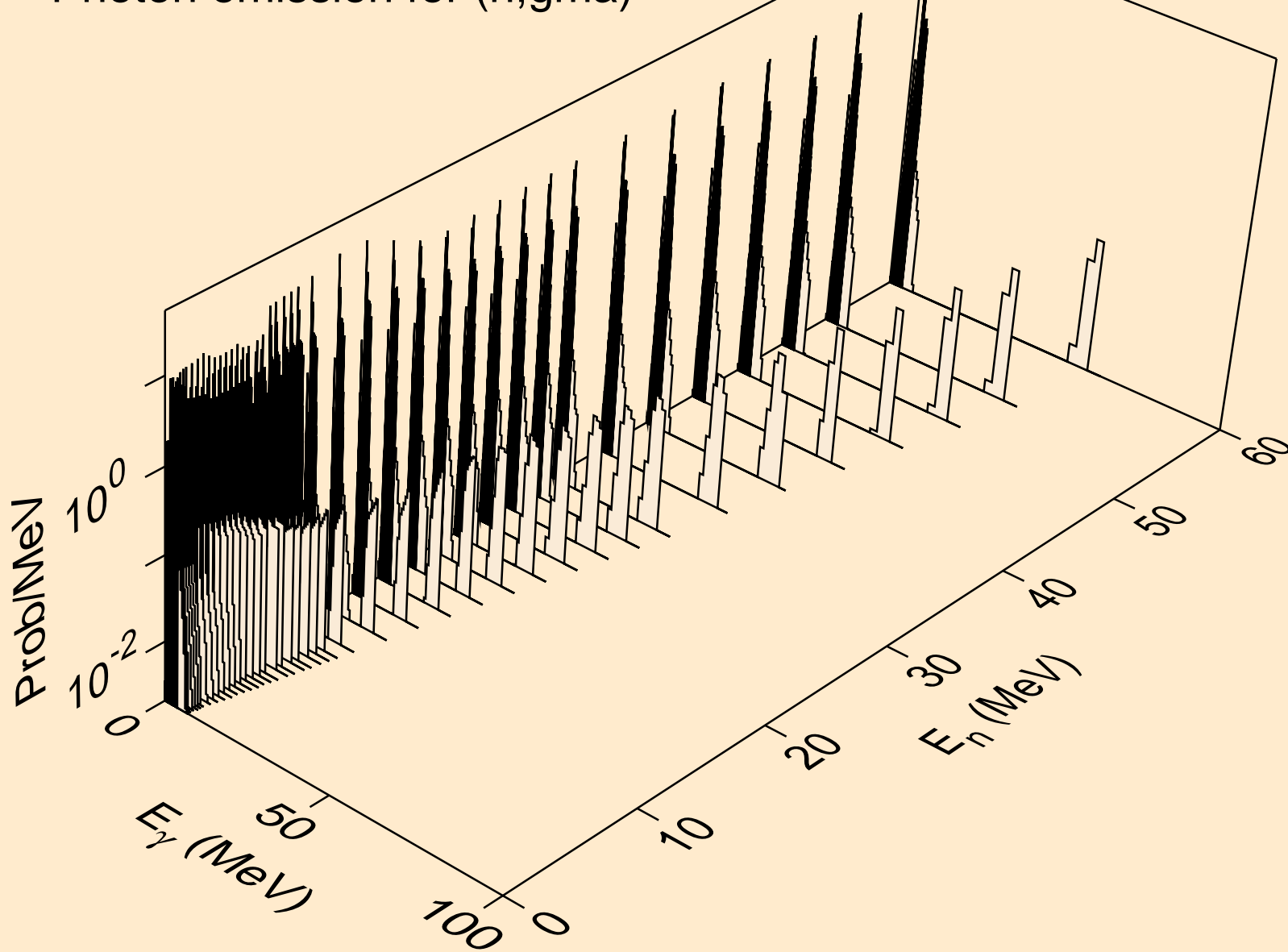

16-S-34 FOR FENDL-3.1 FROM TENDL-2010 WITH NJOY2012.50+
Photon emission for (n,p)

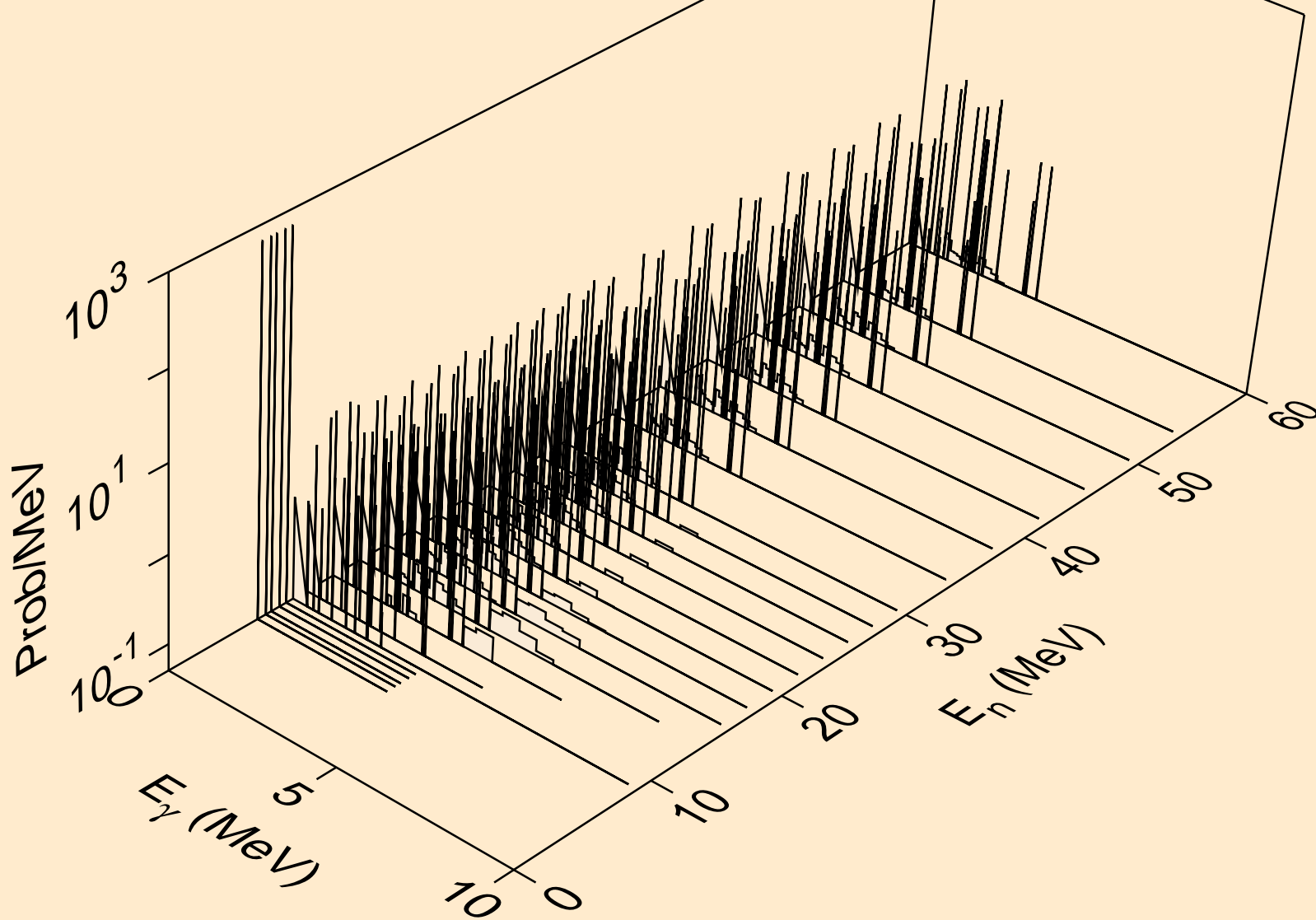

16-S-34 FOR FENDL-3.1 FROM TENDL-2010 WITH NJOY2012.50+
Photon emission for (n,d)

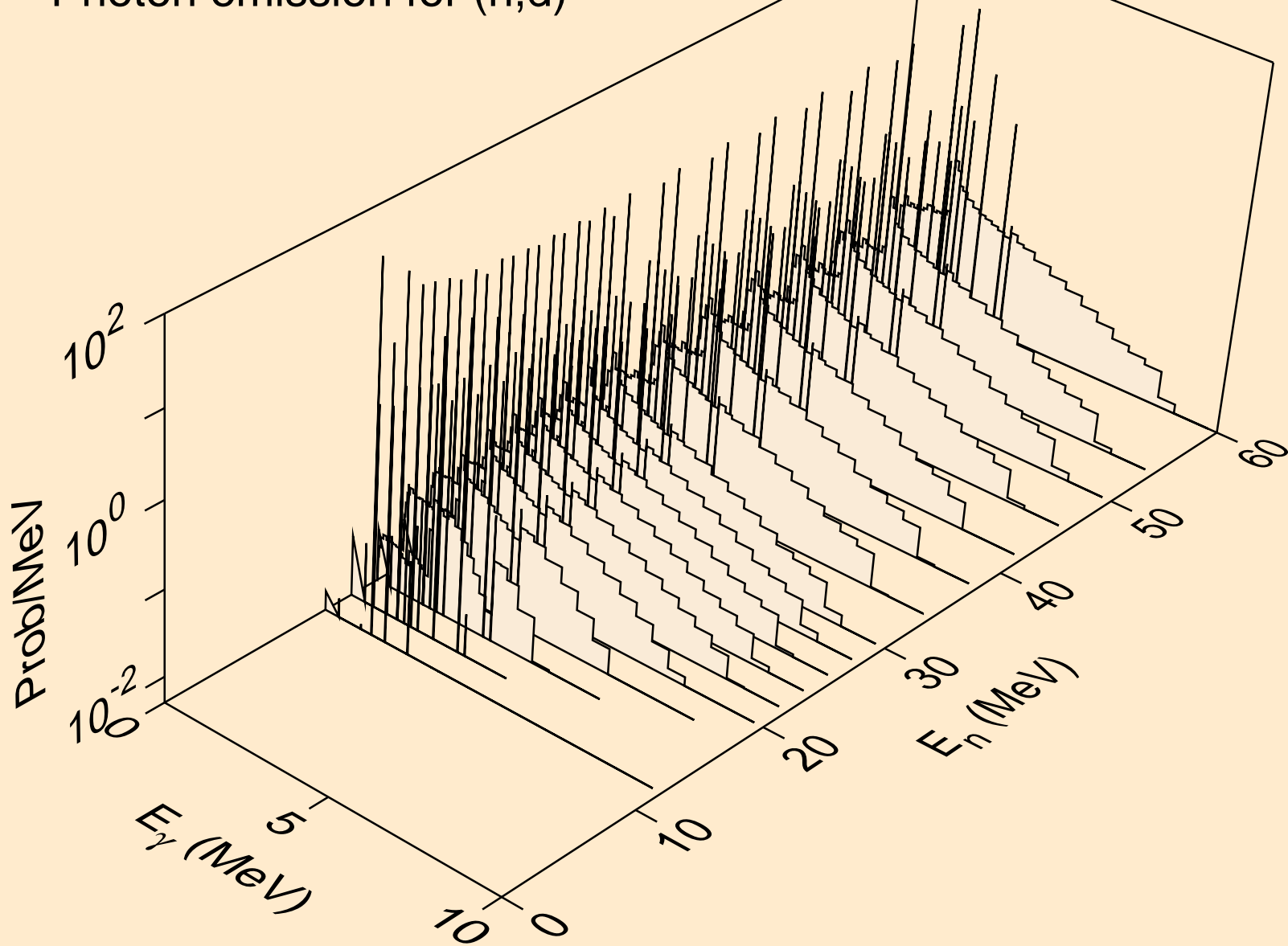

16-S-34 FOR FENDL-3.1 FROM TENDL-2010 WITH NJOY2012.50+
Photon emission for (n,t)

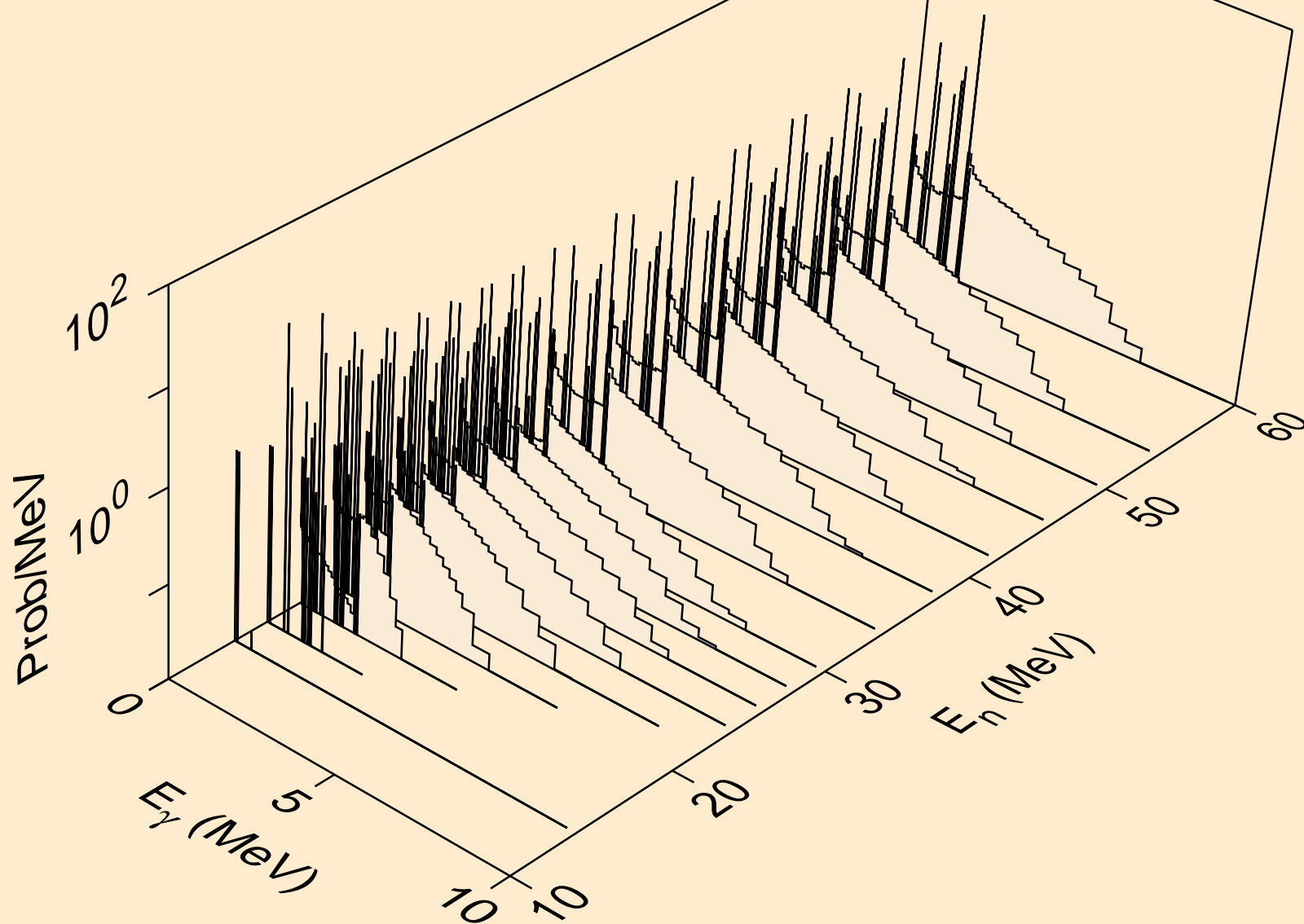

16-S-34 FOR FENDL-3.1 FROM TENDL-2010 WITH NJOY2012.50+
Photon emission for (n,he3)

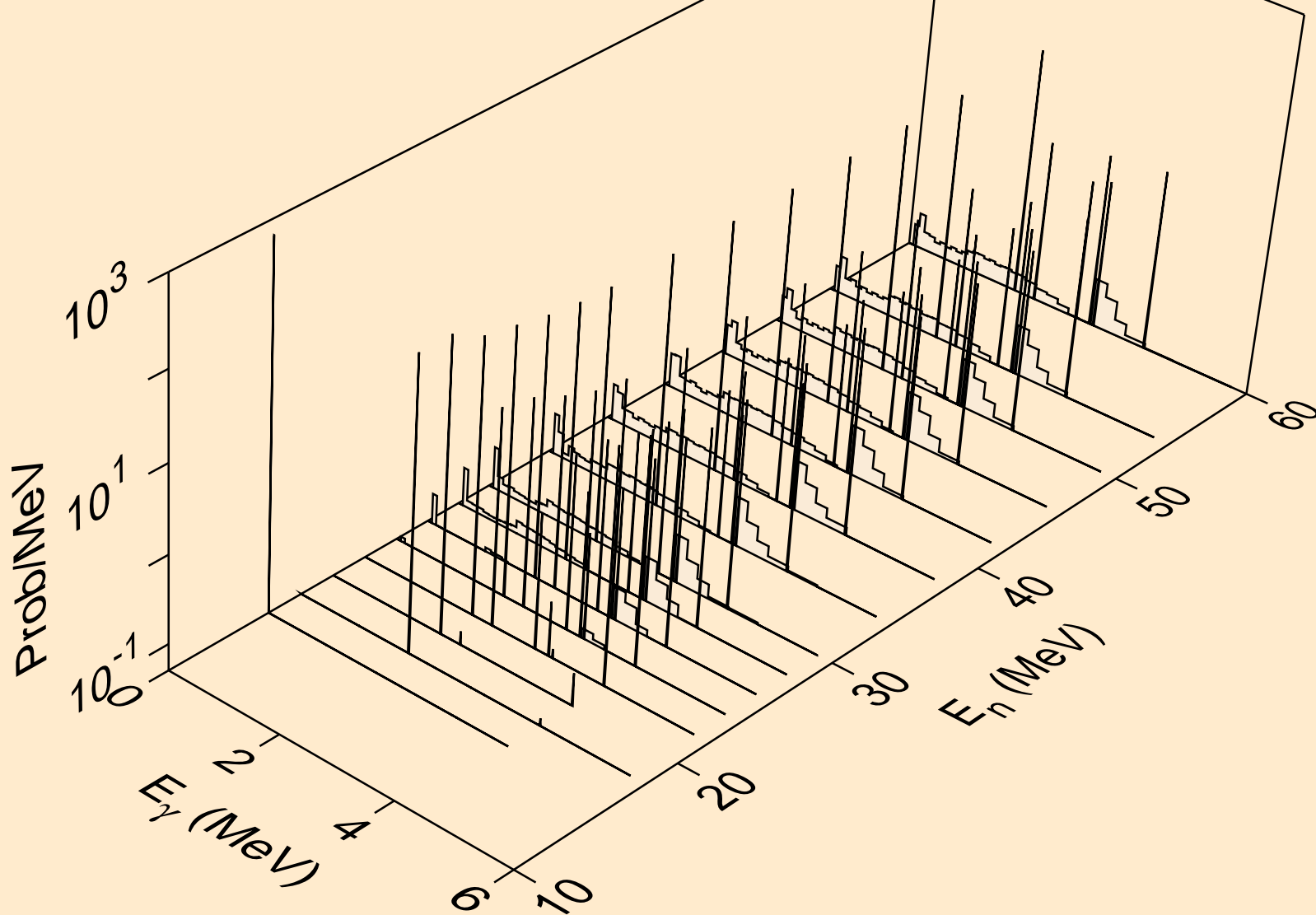

16-S-34 FOR FENDL-3.1 FROM TENDL-2010 WITH NJOY2012.50+
Photon emission for (n,a)

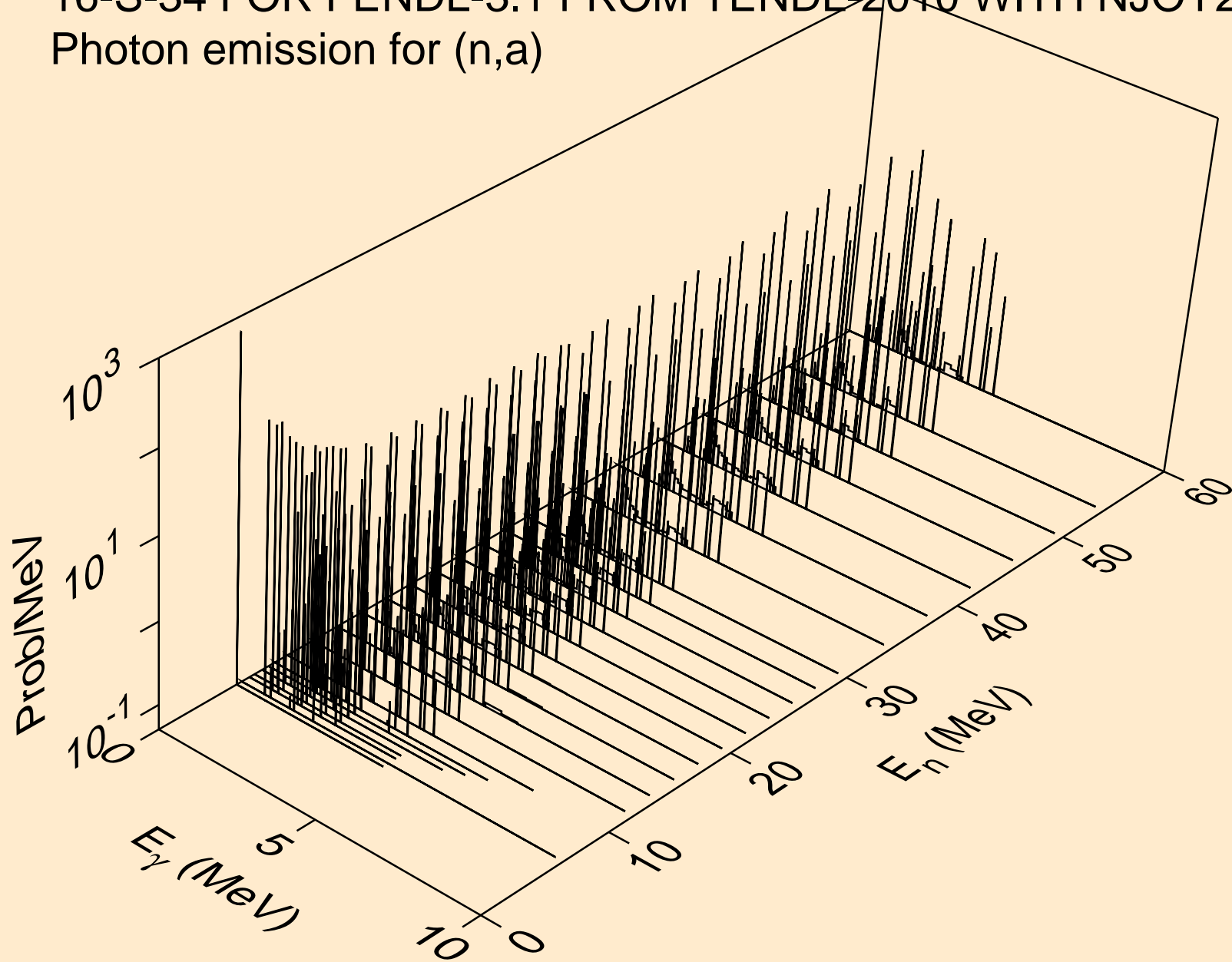

16-S-34 FOR FENDL-3.1 FROM TENDL-2010 WITH NJOY2012.50+
Photon emission for (n,2a)

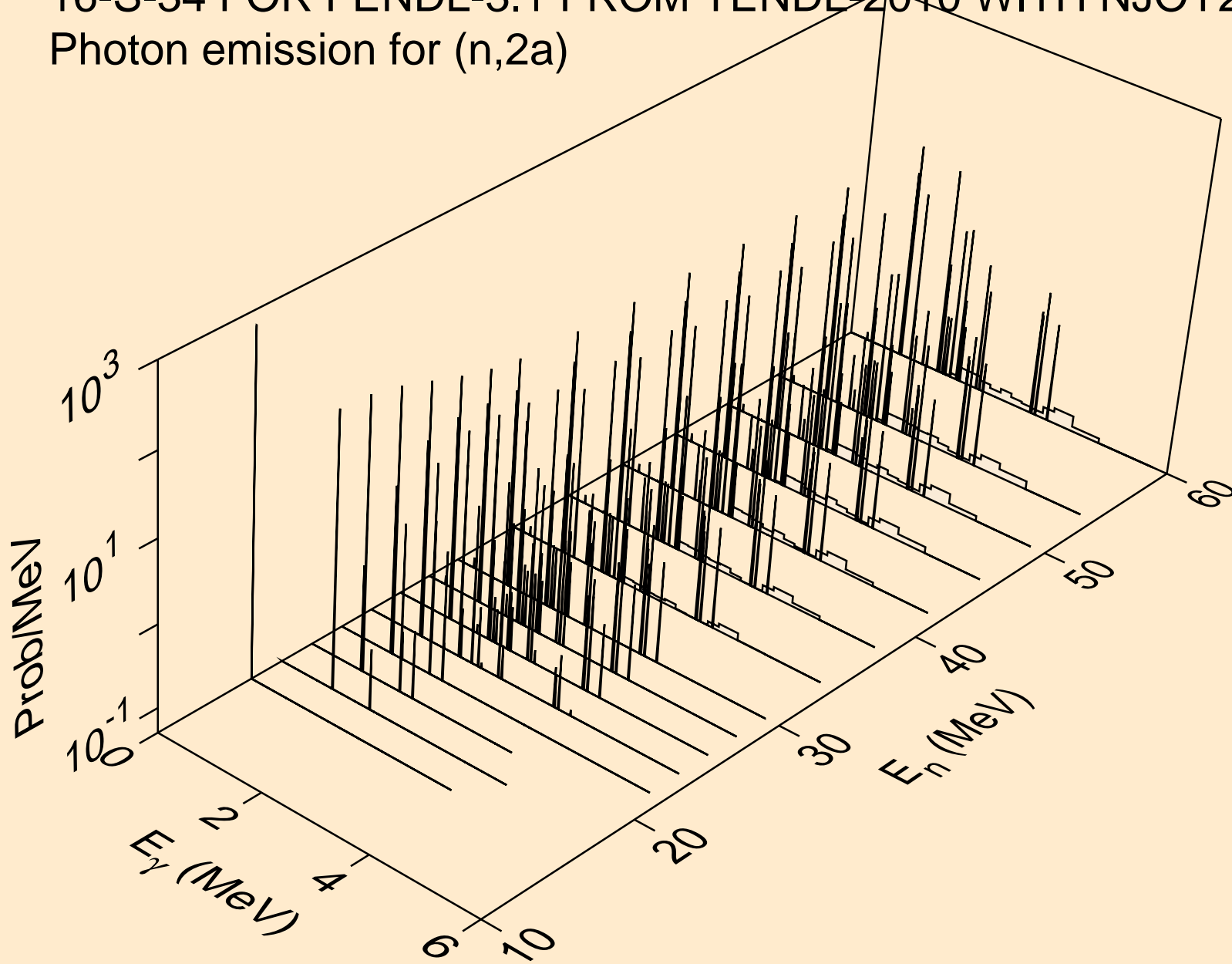

16-S-34 FOR FENDL-3.1 FROM TENDL-2010 WITH NJOY2012.50+
Photon emission for (n,3a)

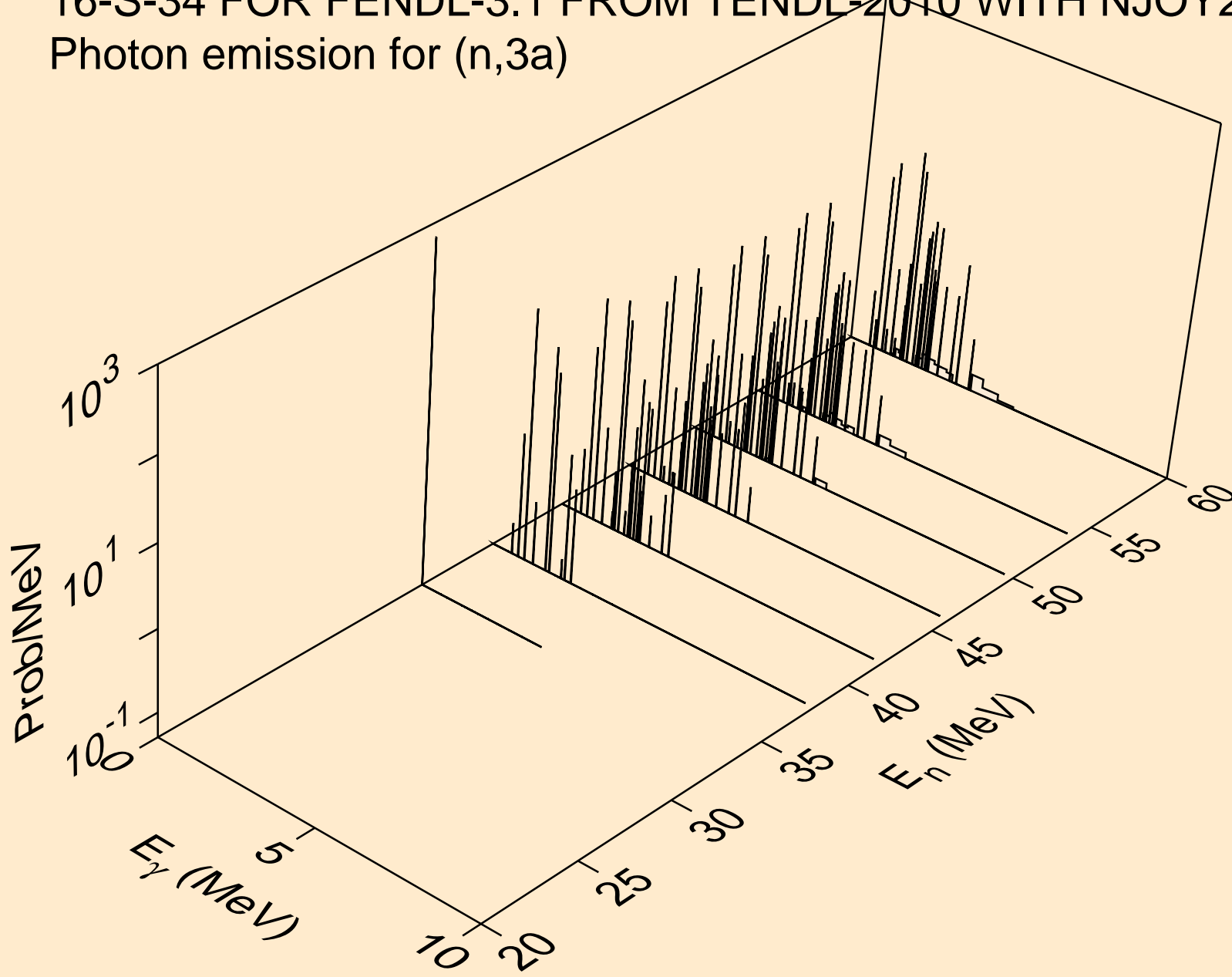

16-S-34 FOR FENDL-3.1 FROM TENDL-2010 WITH NJOY2012.50+
Photon emission for (n,2p)

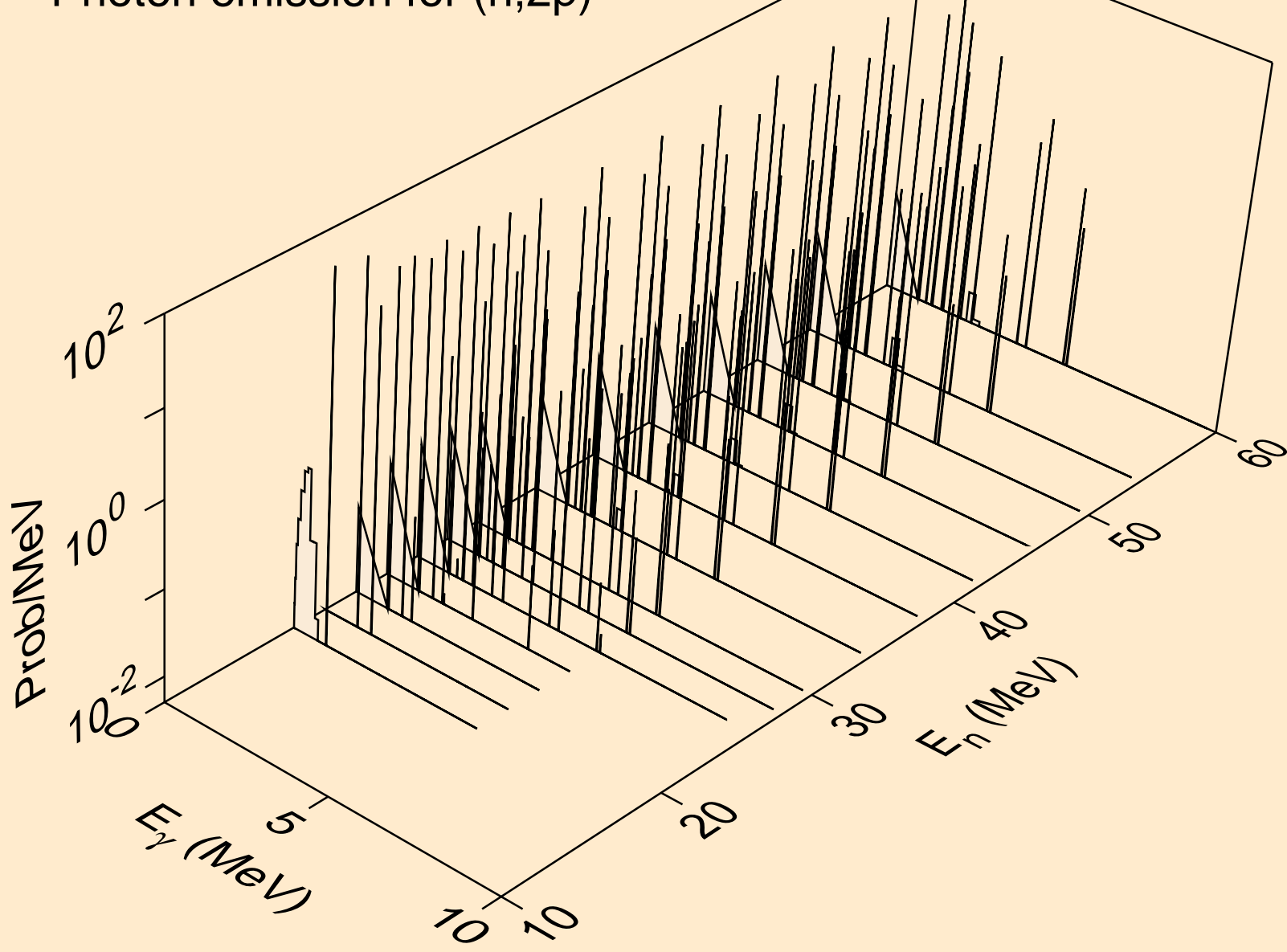

16-S-34 FOR FENDL-3.1 FROM TENDL-2010 WITH NJOY2012.50+
Photon emission for (n,pa)

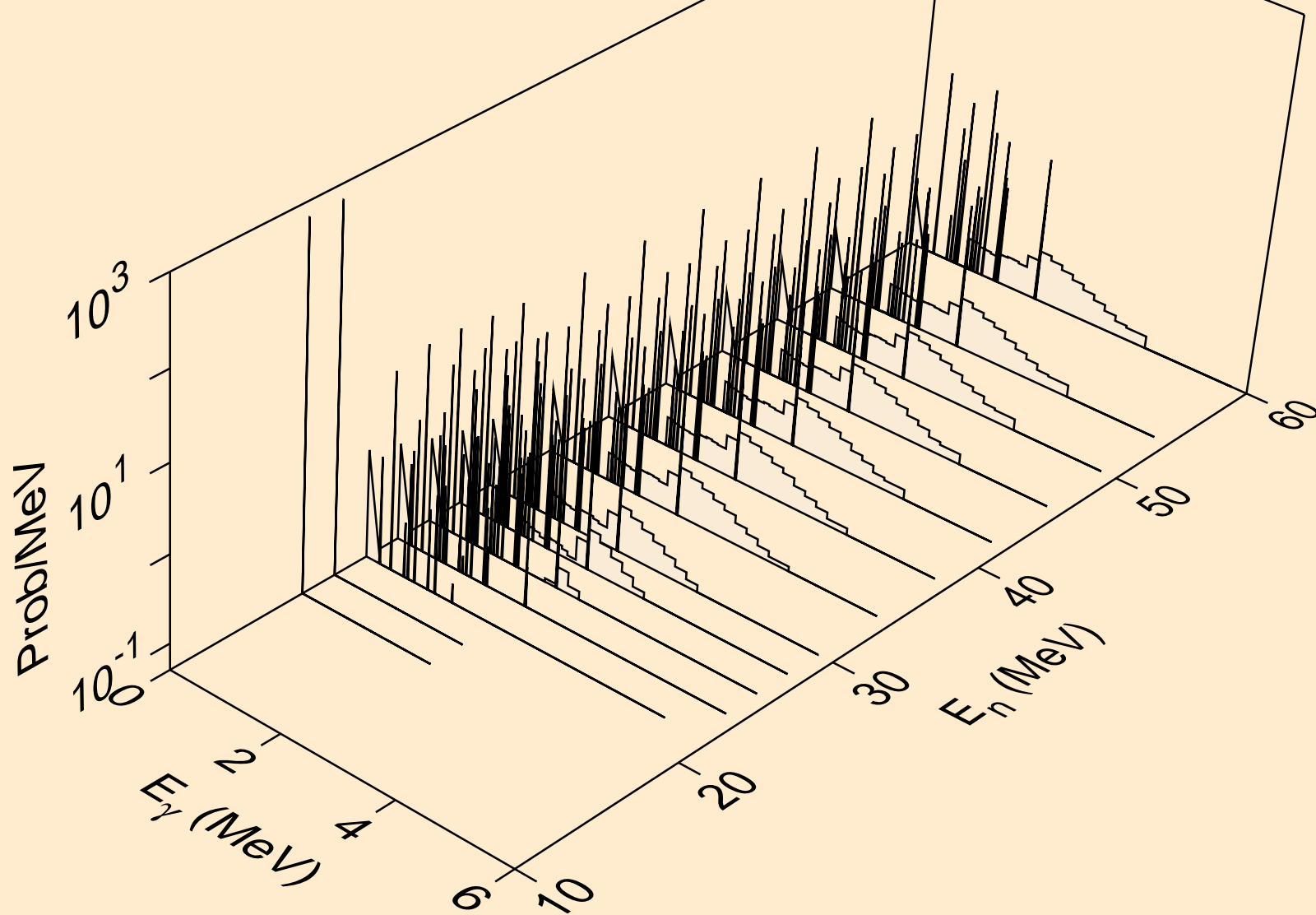

16-S-34 FOR FENDL-3.1 FROM TENDL-2010 WITH NJOY2012.50+
Photon emission for (n,t2a)

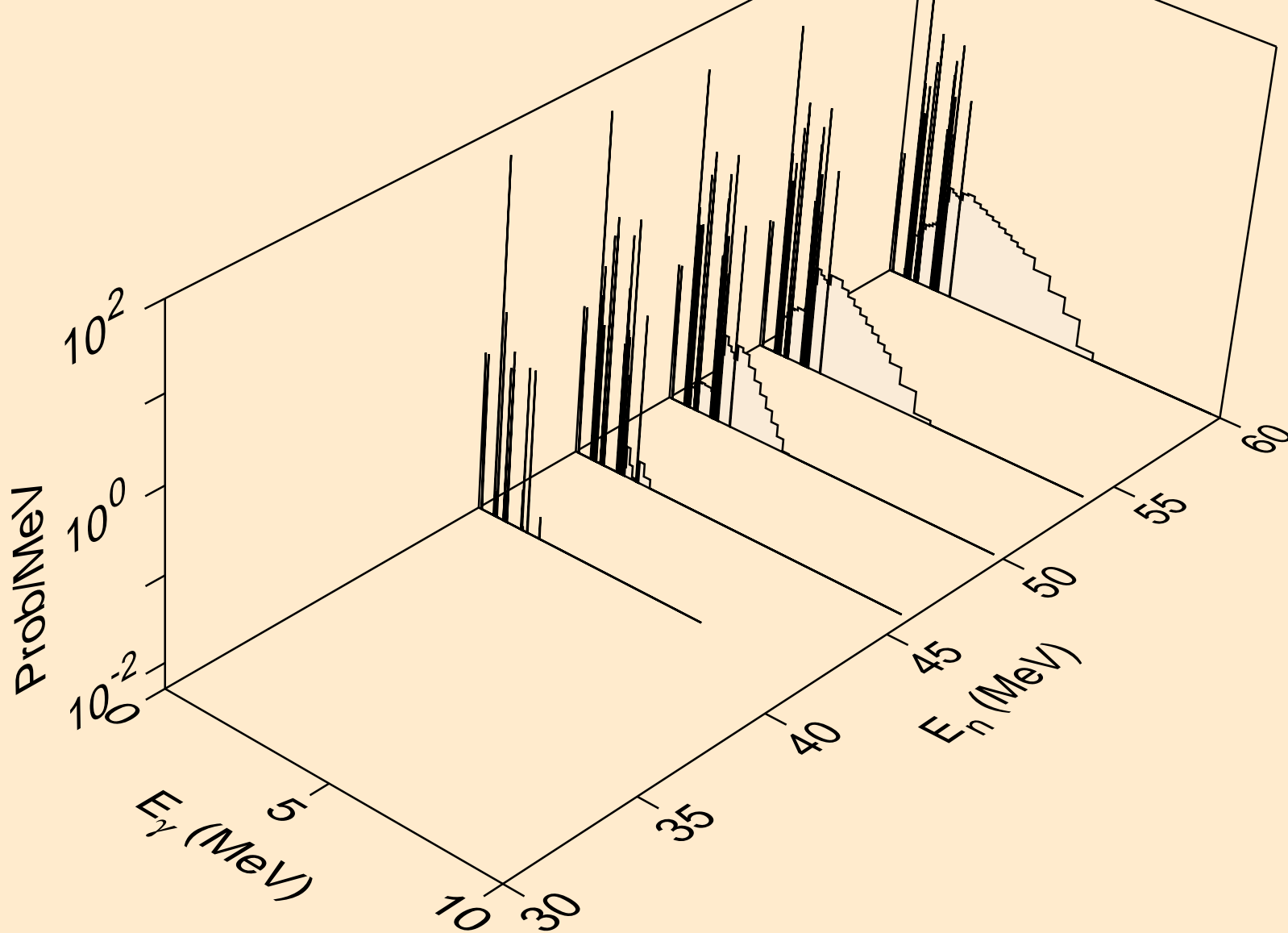

16-S-34 FOR FENDL-3.1 FROM TENDL-2010 WITH NJOY2012.50+
Photon emission for (n,d2a)

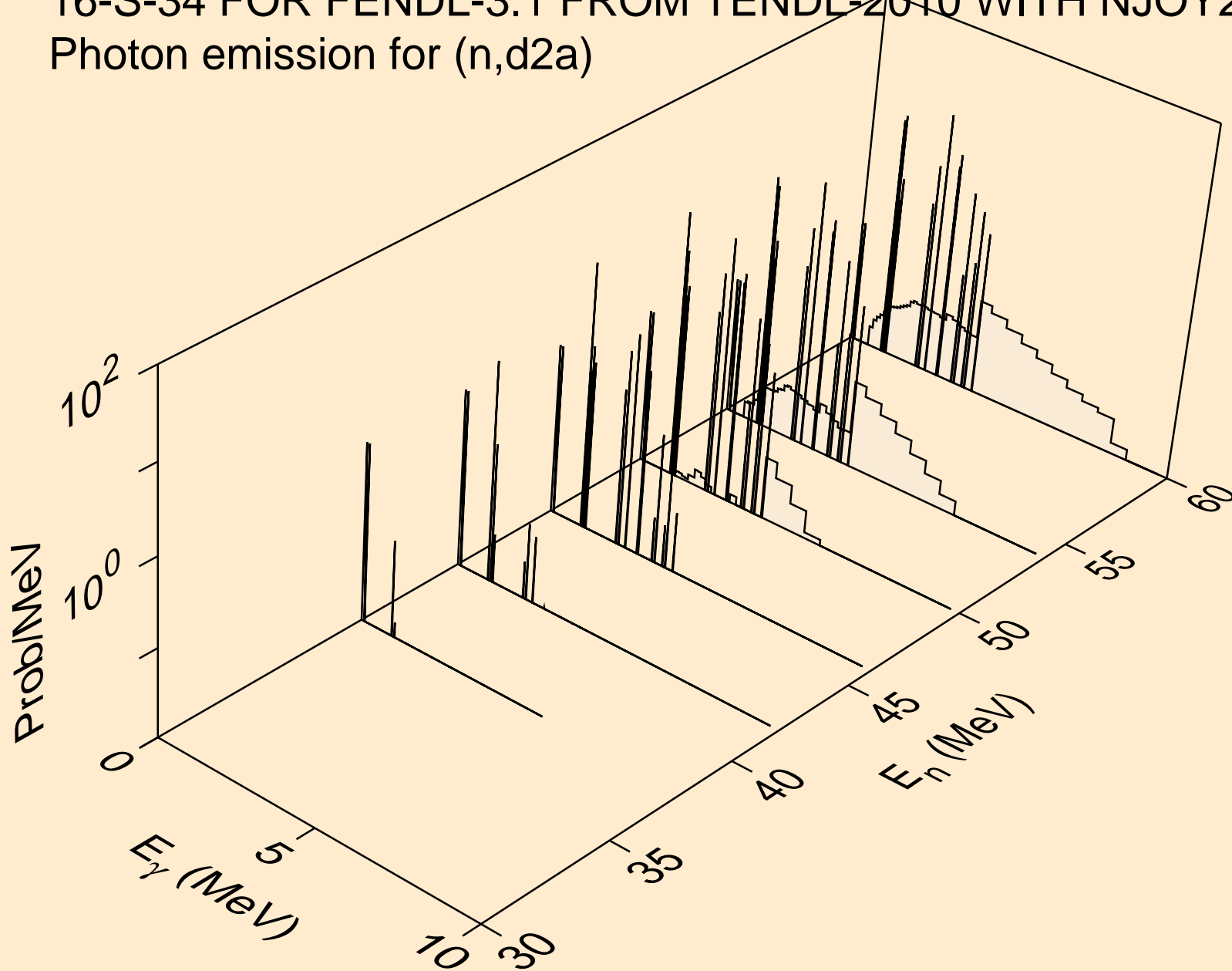

16-S-34 FOR FENDL-3.1 FROM TENDL-2010 WITH NJOY2012.50+
Photon emission for (n,pd)

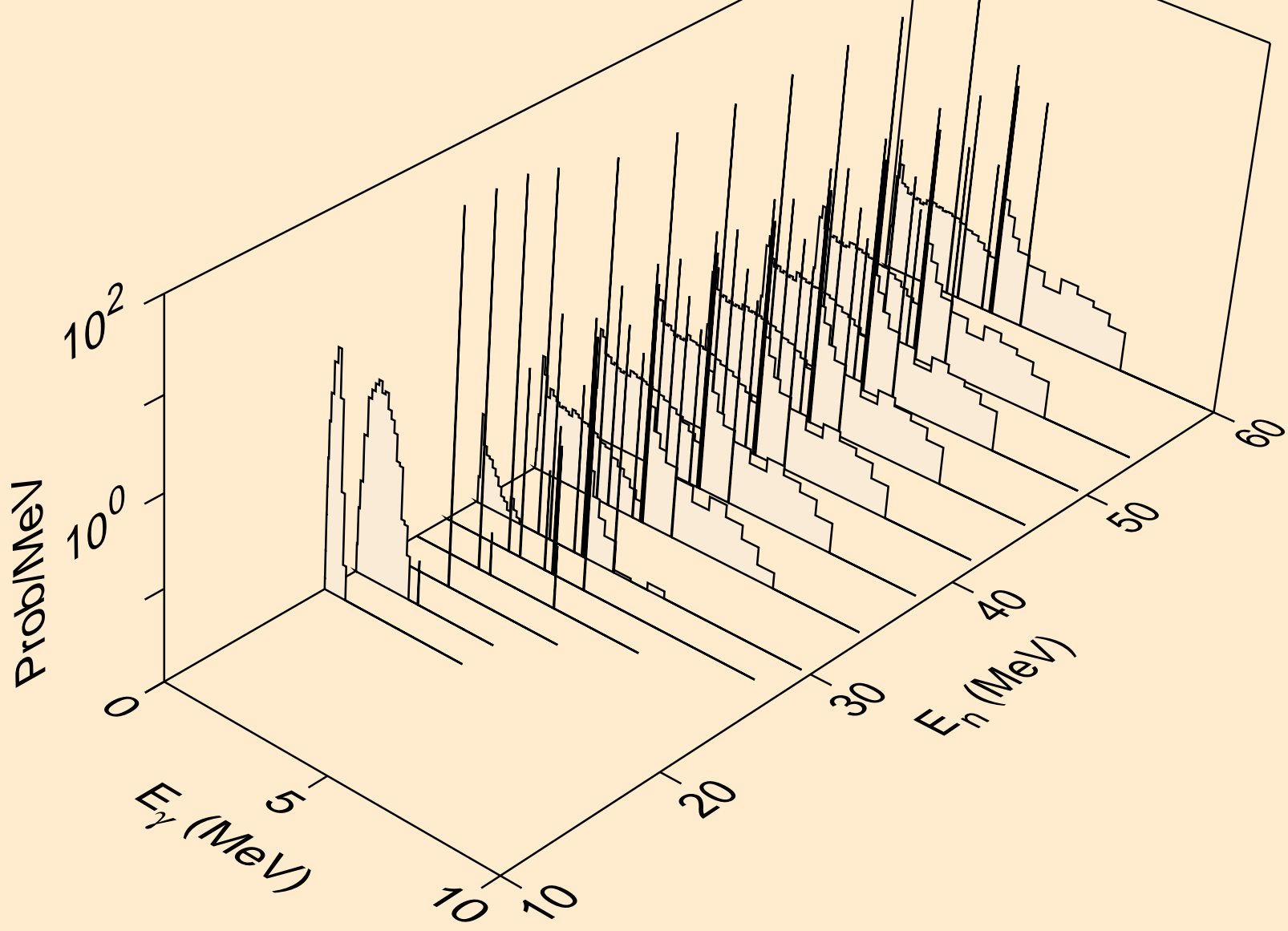

16-S-34 FOR FENDL-3.1 FROM TENDL-2010 WITH NJOY2012.50+
Photon emission for (n,pt)

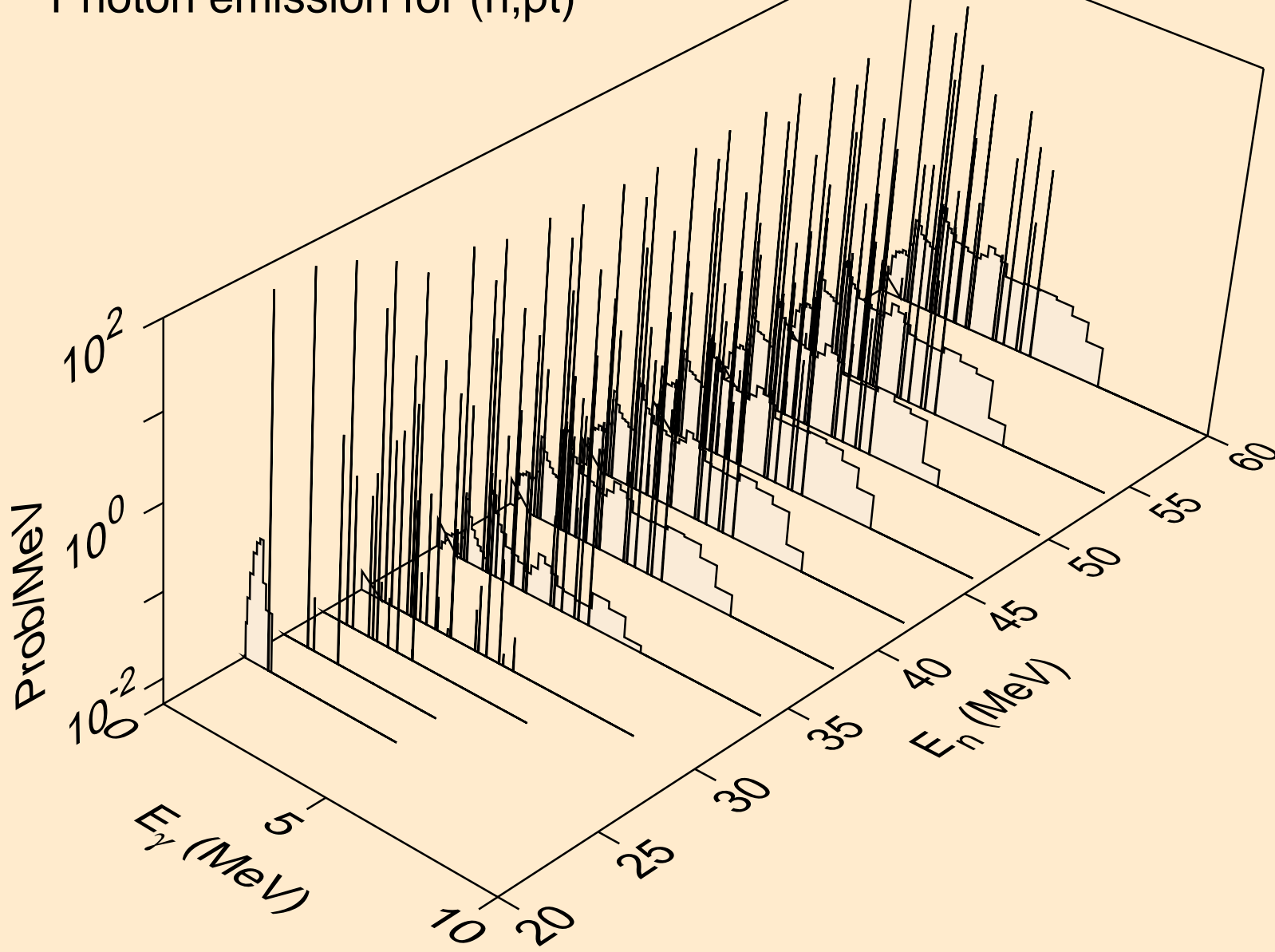

16-S-34 FOR FENDL-3.1 FROM TENDL-2010 WITH NJOY2012.50+
Photon emission for (n,da)

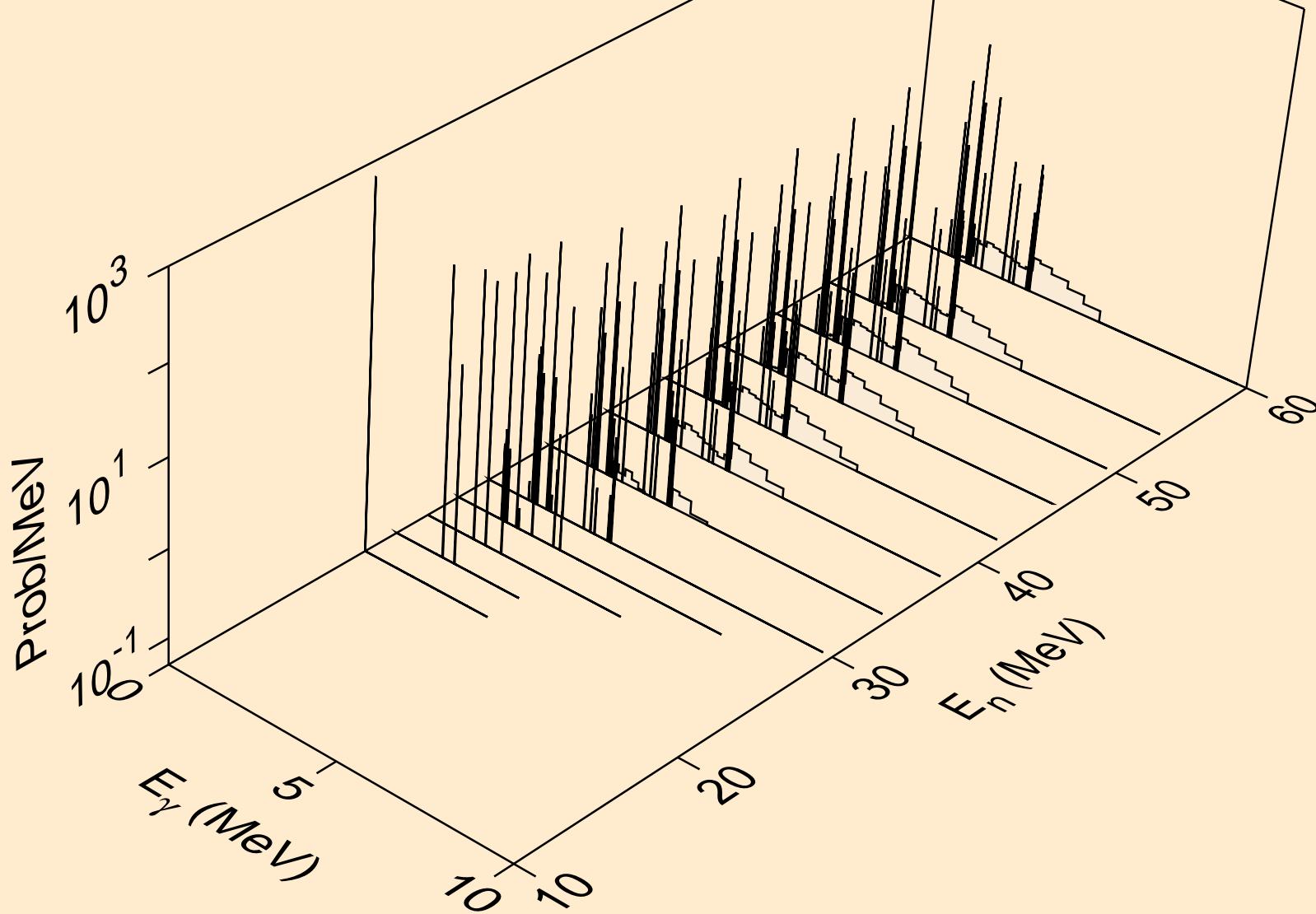

16-S-34 FOR FENDL-3.1 FROM TENDL-2010 WITH NJOY2012.50+
Photon emission for (n,5n)

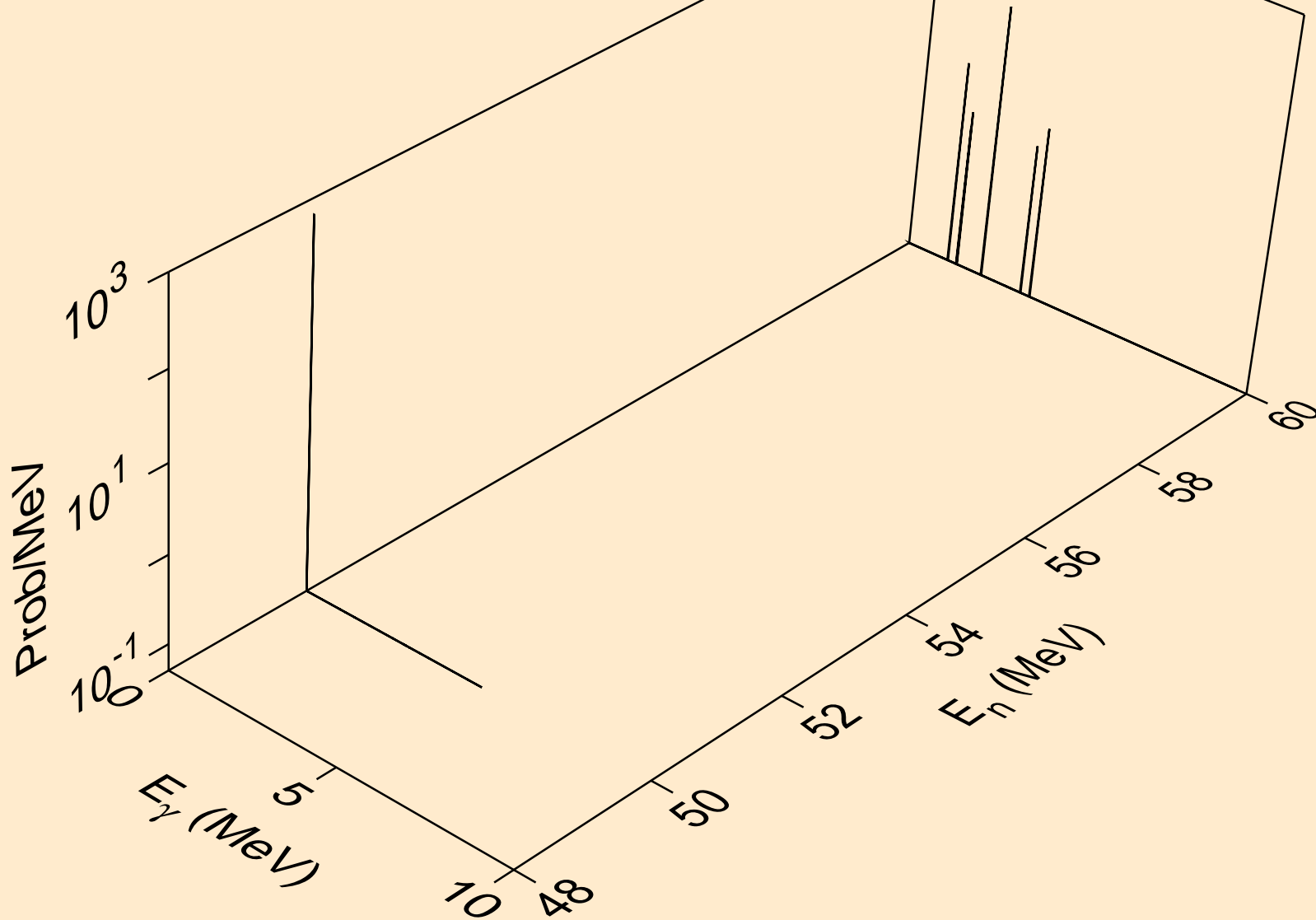

16-S-34 FOR FENDL-3.1 FROM TENDL-2010 WITH NJOY2012.50+
Photon emission for (n,2nt)

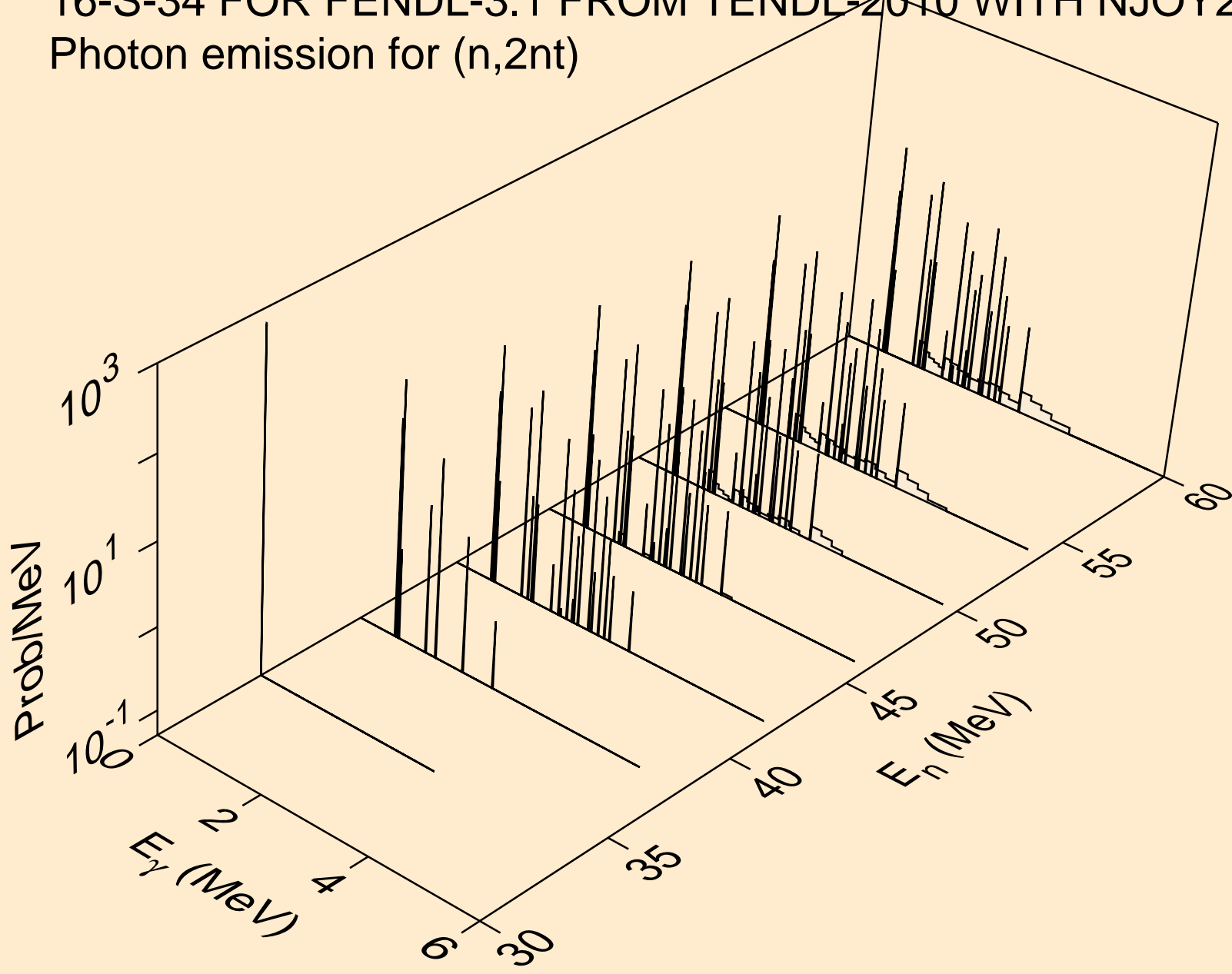

16-S-34 FOR FENDL-3.1 FROM TENDL-2010 WITH NJOY2012.50+
Photon emission for (n,ta)

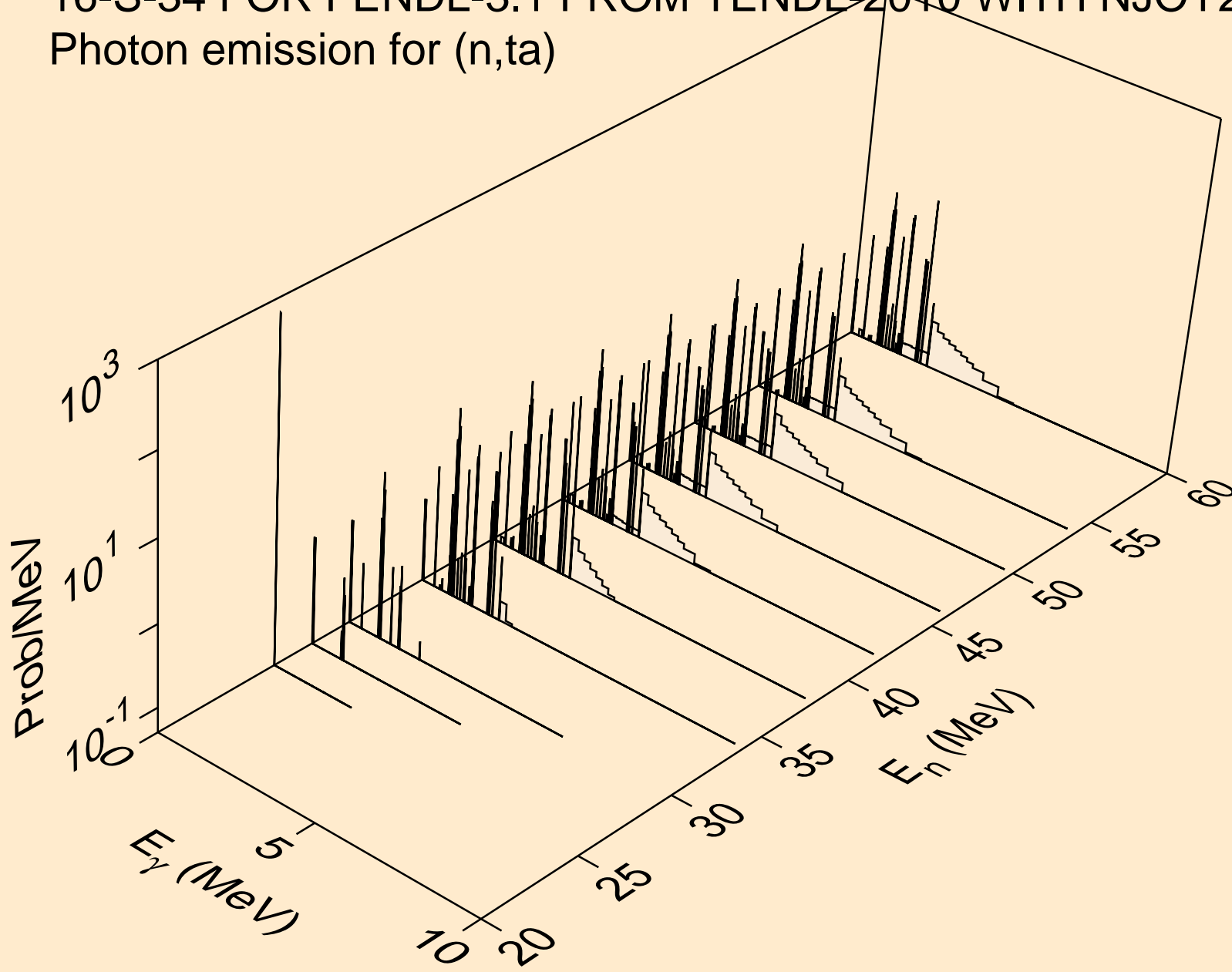

16-S-34 FOR FENDL-3.1 FROM TENDL-2010 WITH NJOY2012.50+
Photon emission for (n,4np)

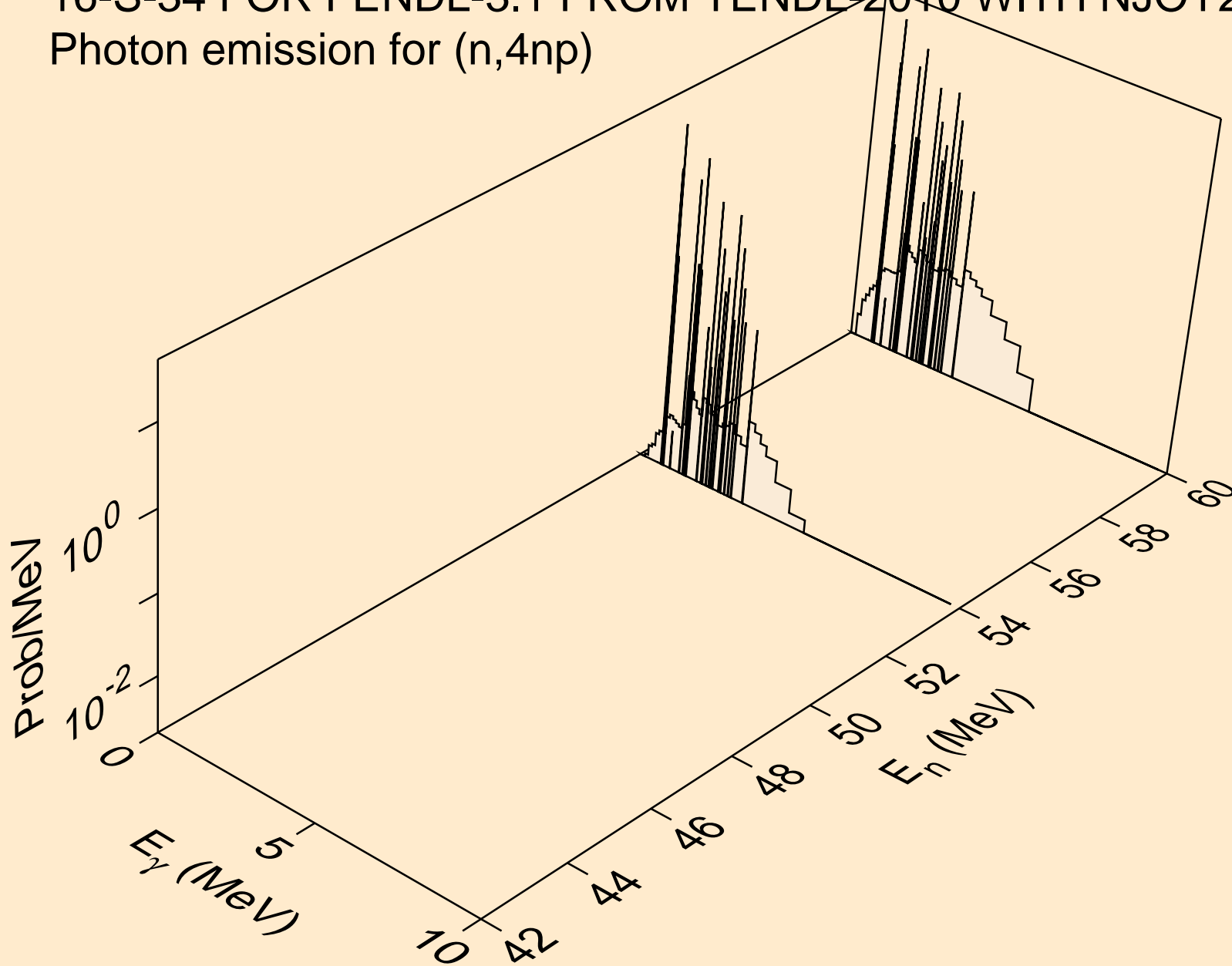

16-S-34 FOR FENDL-3.1 FROM TENDL-2010 WITH NJOY2012.50+
Photon emission for (n,3nd)

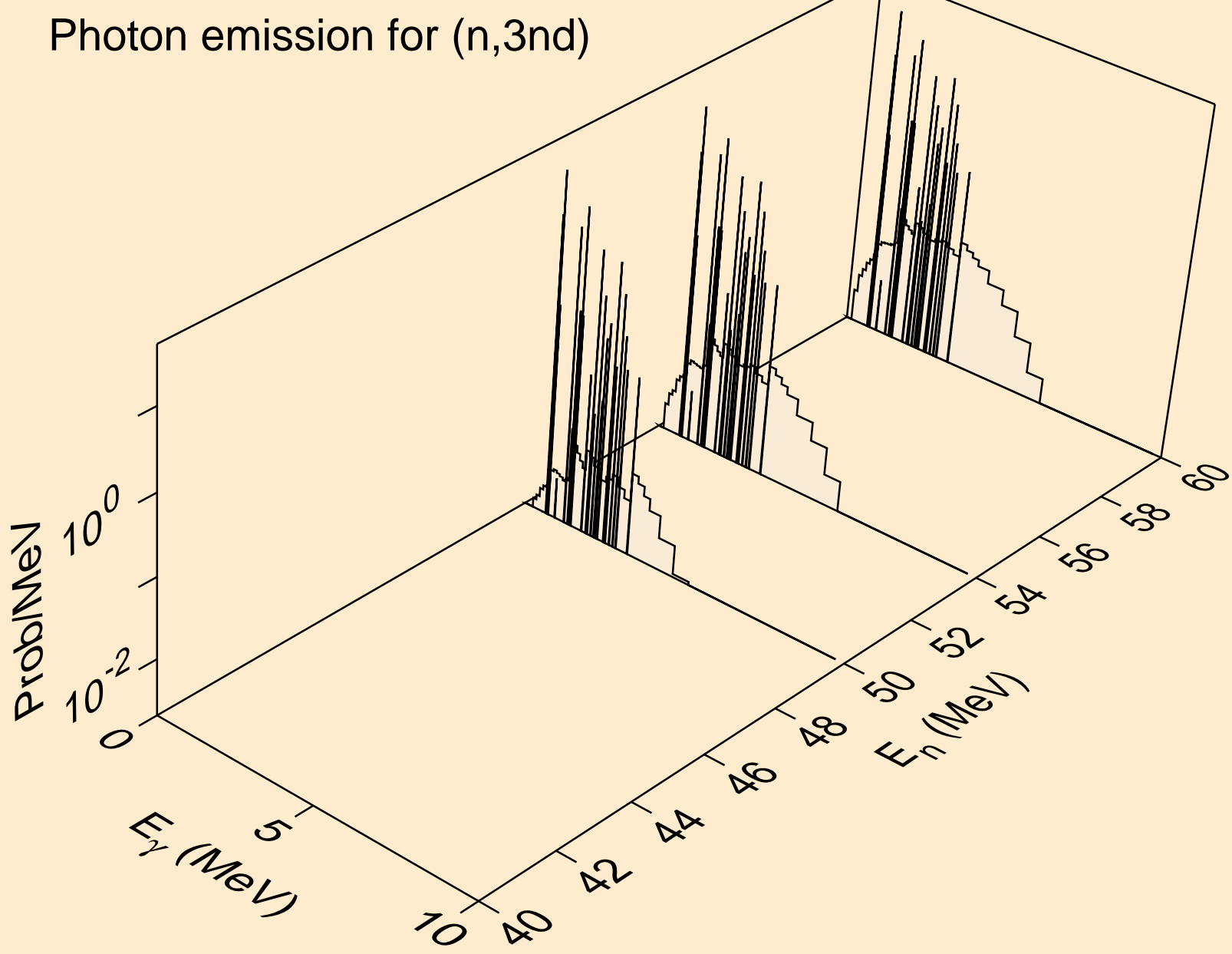

16-S-34 FOR FENDL-3.1 FROM TENDL-2010 WITH NJOY2012.50+
Photon emission for (n,nda)

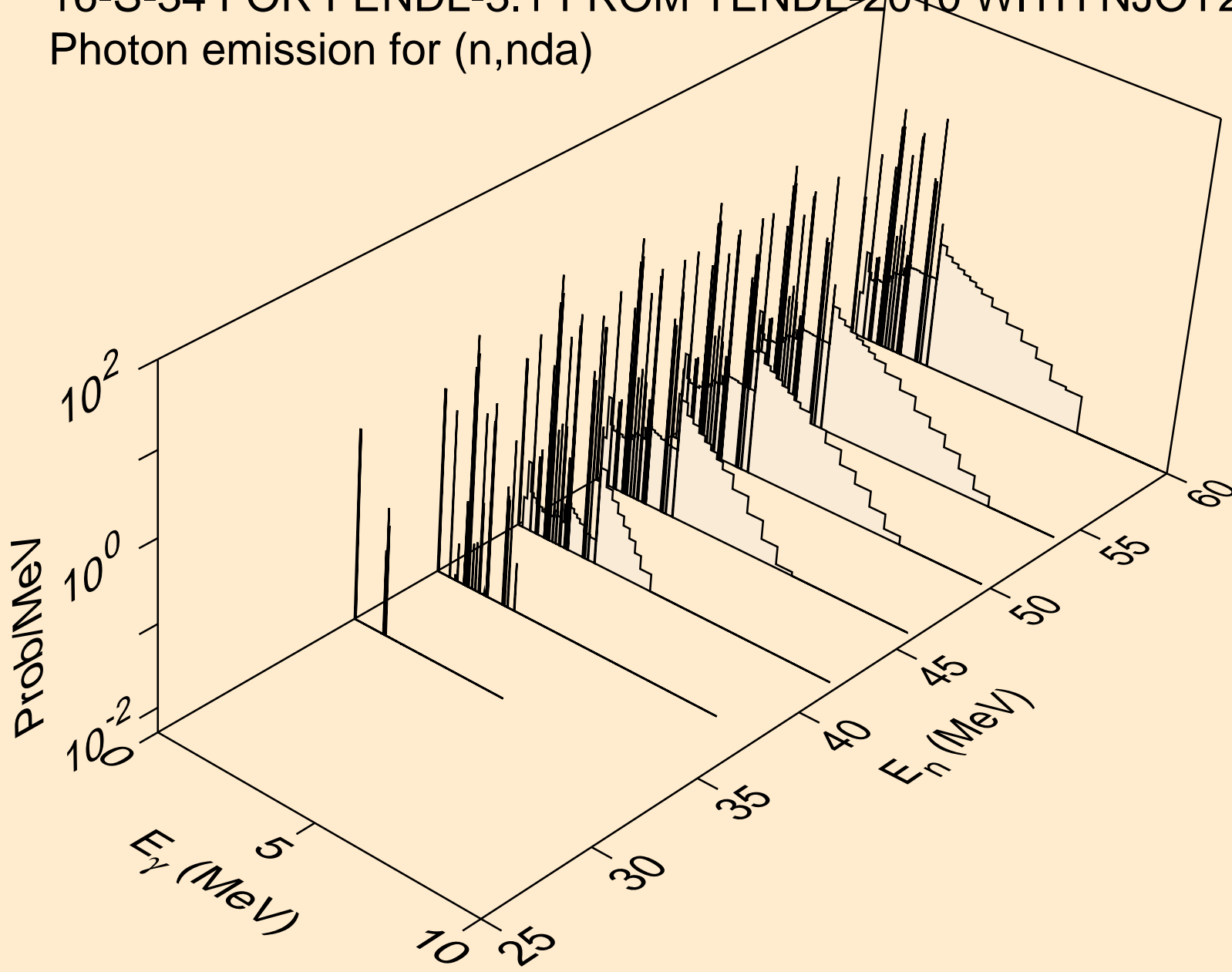

16-S-34 FOR FENDL-3.1 FROM TENDL-2010 WITH NJOY2012.50+
Photon emission for (n,2npa)

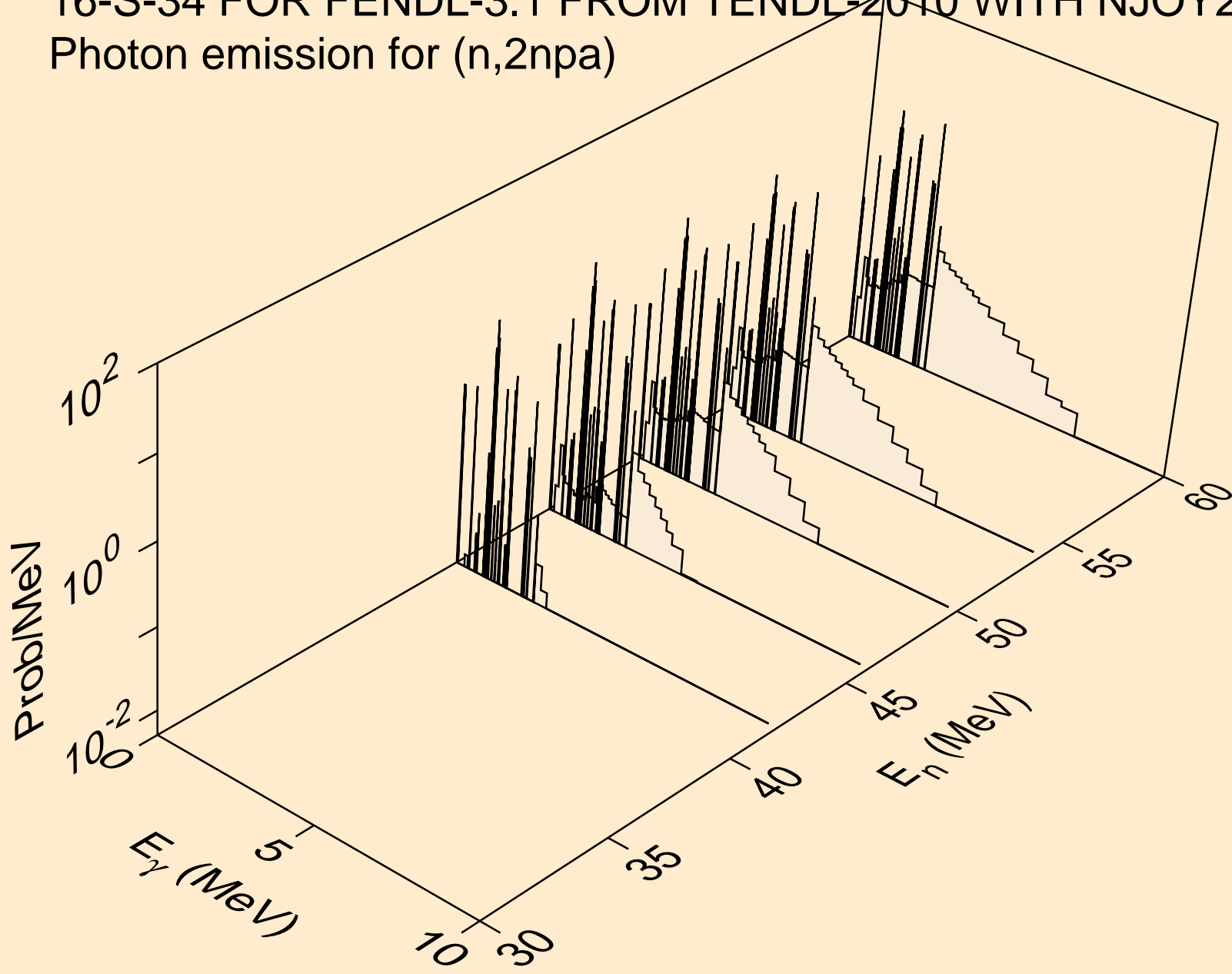

16-S-34 FOR FENDL-3.1 FROM TENDL-2010 WITH NJOY2012.50+
Photon emission for (n,5np)

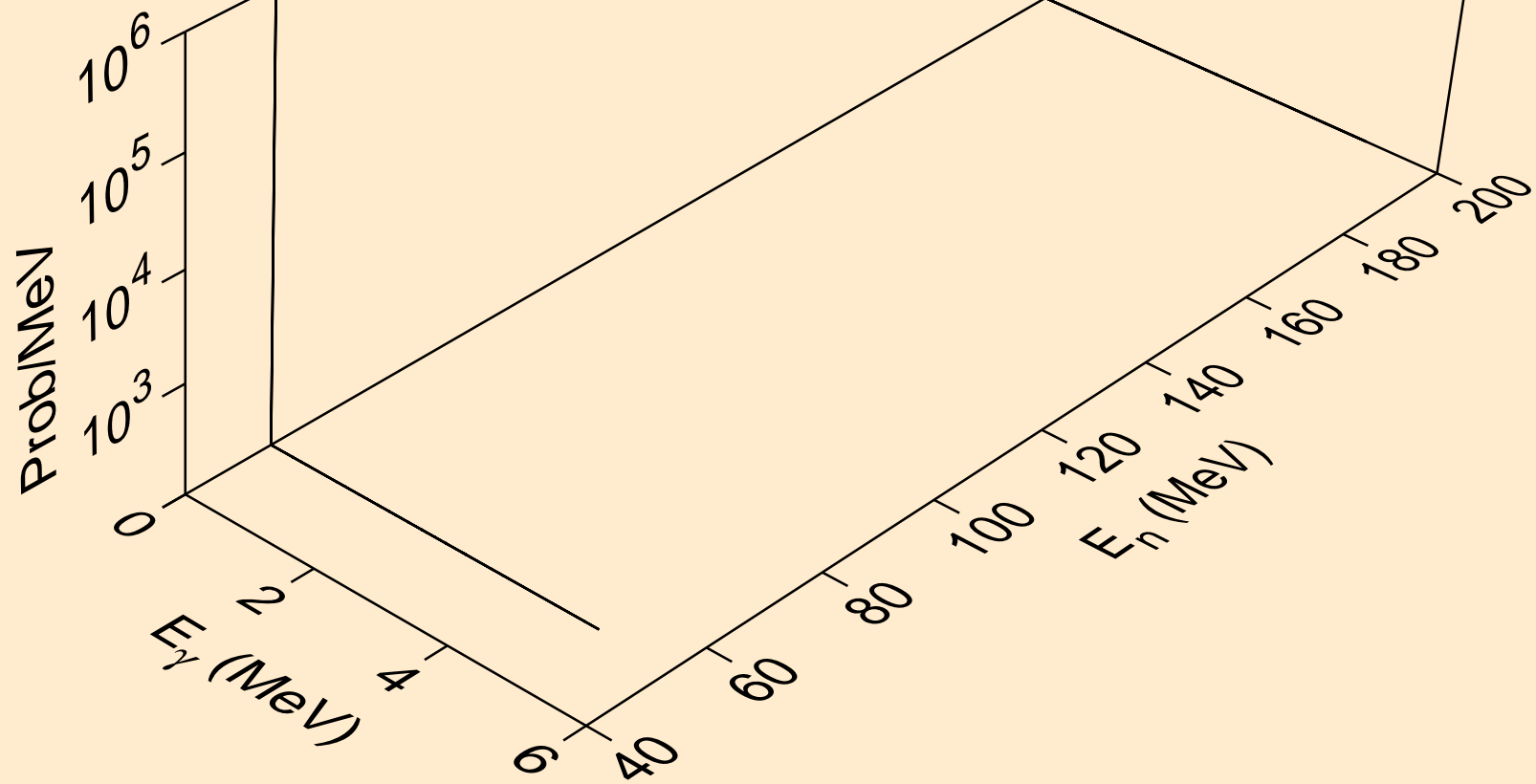

16-S-34 FOR FENDL-3.1 FROM TENDL-2010 WITH NJOY2012.50+
Photon emission for (n,4na)

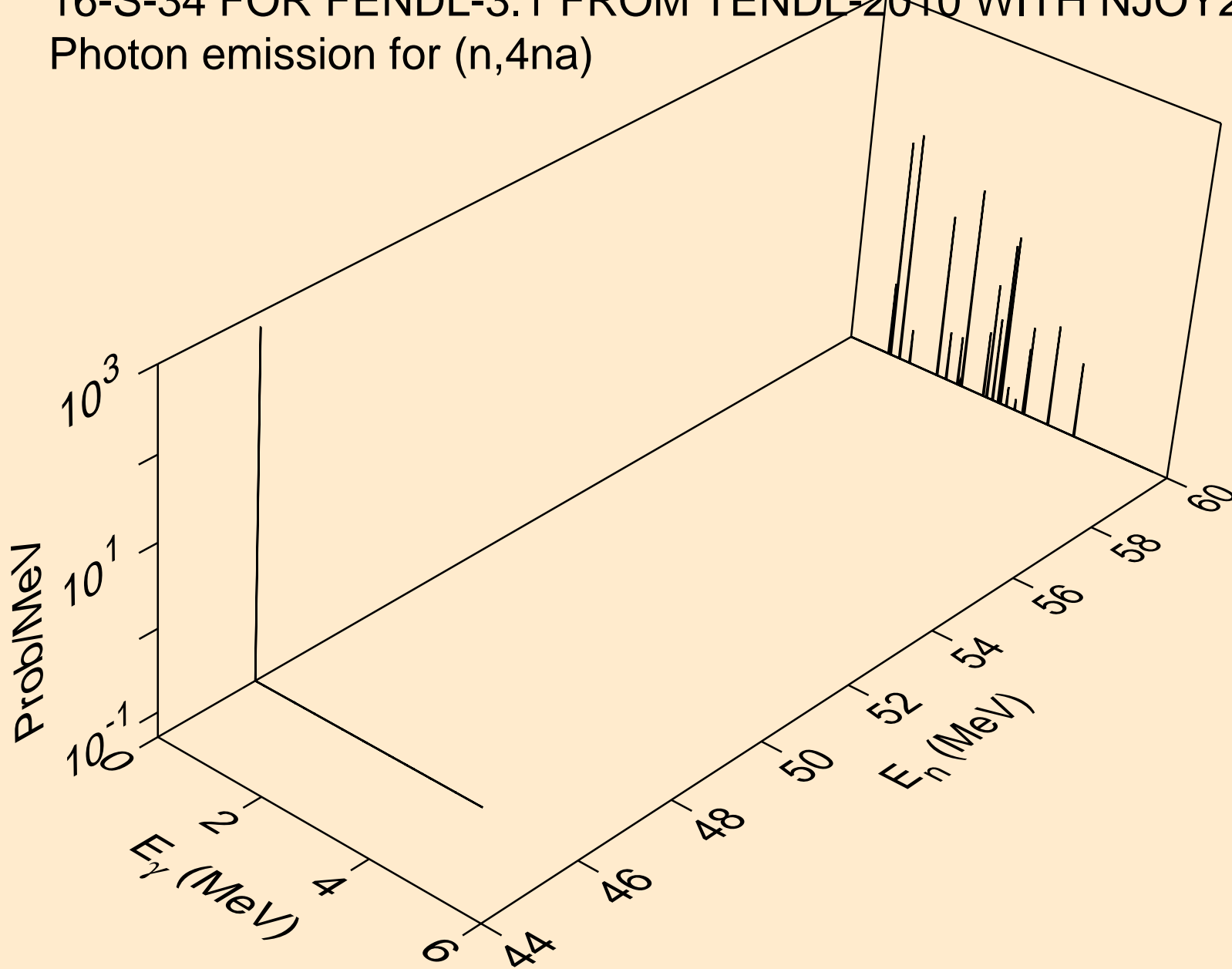

16-S-34 FOR FENDL-3.1 FROM TENDL-2010 WITH NJOY2012.50+
Photon emission for (n,4nd)

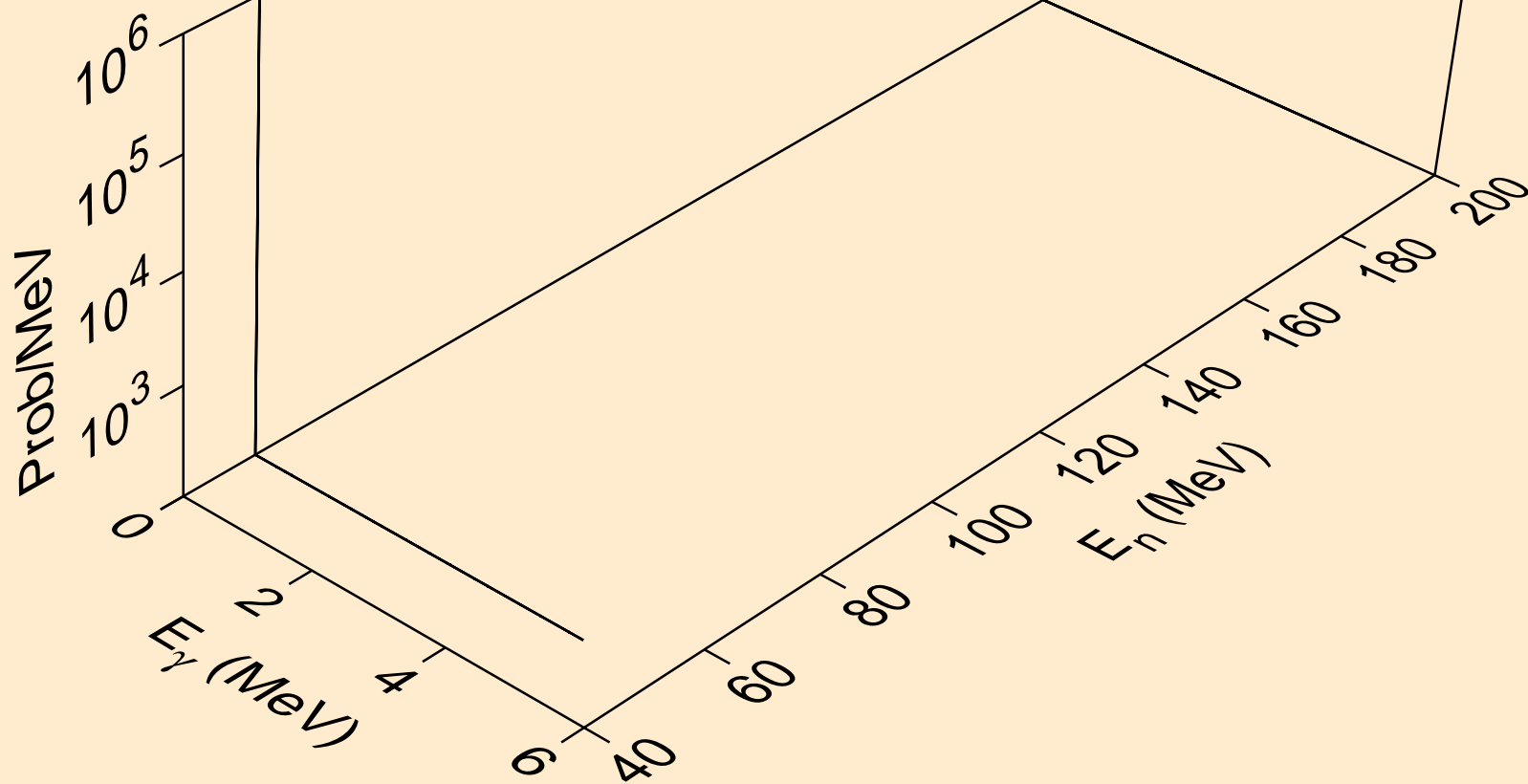

16-S-34 FOR FENDL-3.1 FROM TENDL-2010 WITH NJOY2012.50+
Photon emission for (n,3nt)

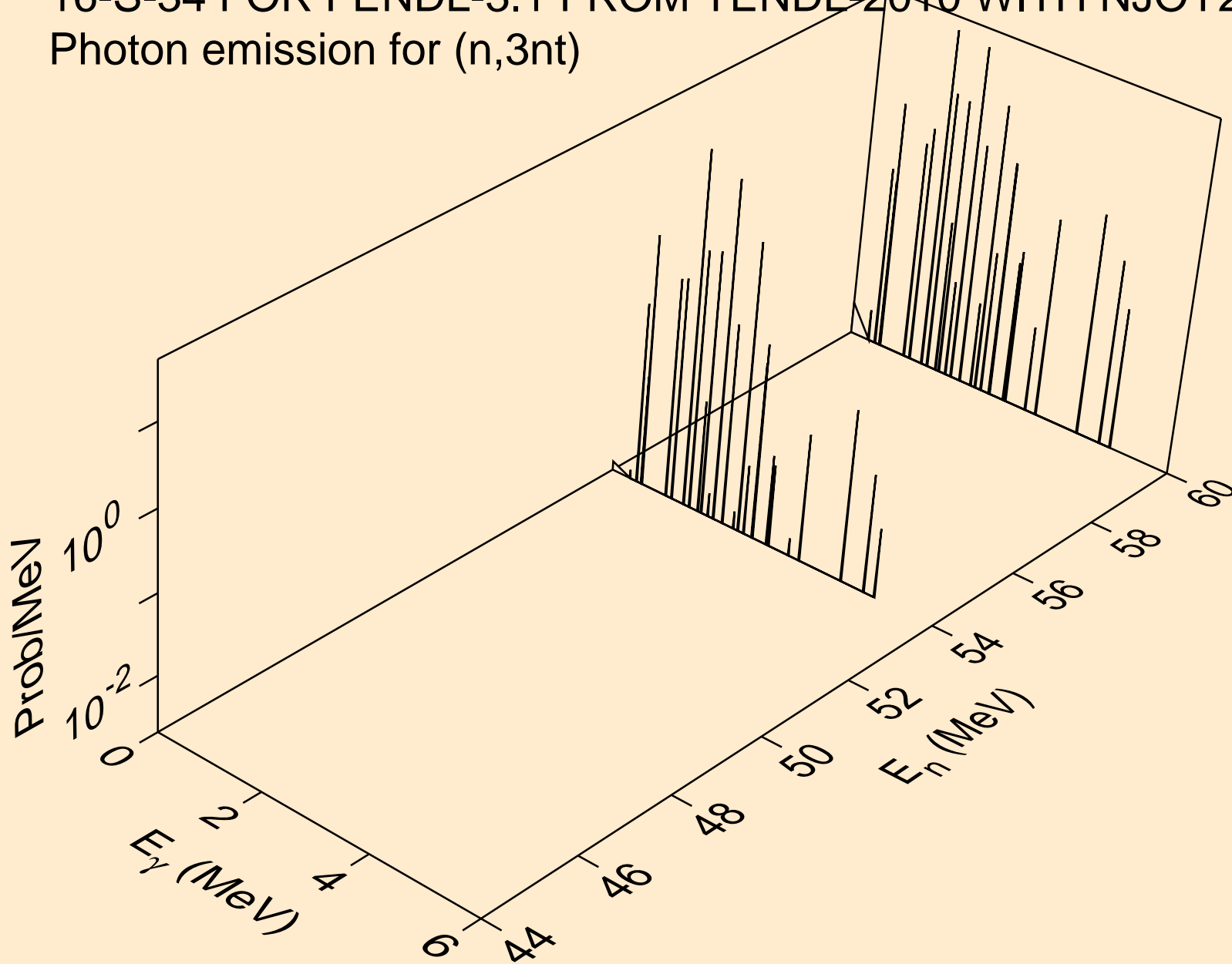

16-S-34 FOR FENDL-3.1 FROM TENDL-2010 WITH NJOY2012.50+
Photon emission for (n,2n)he3

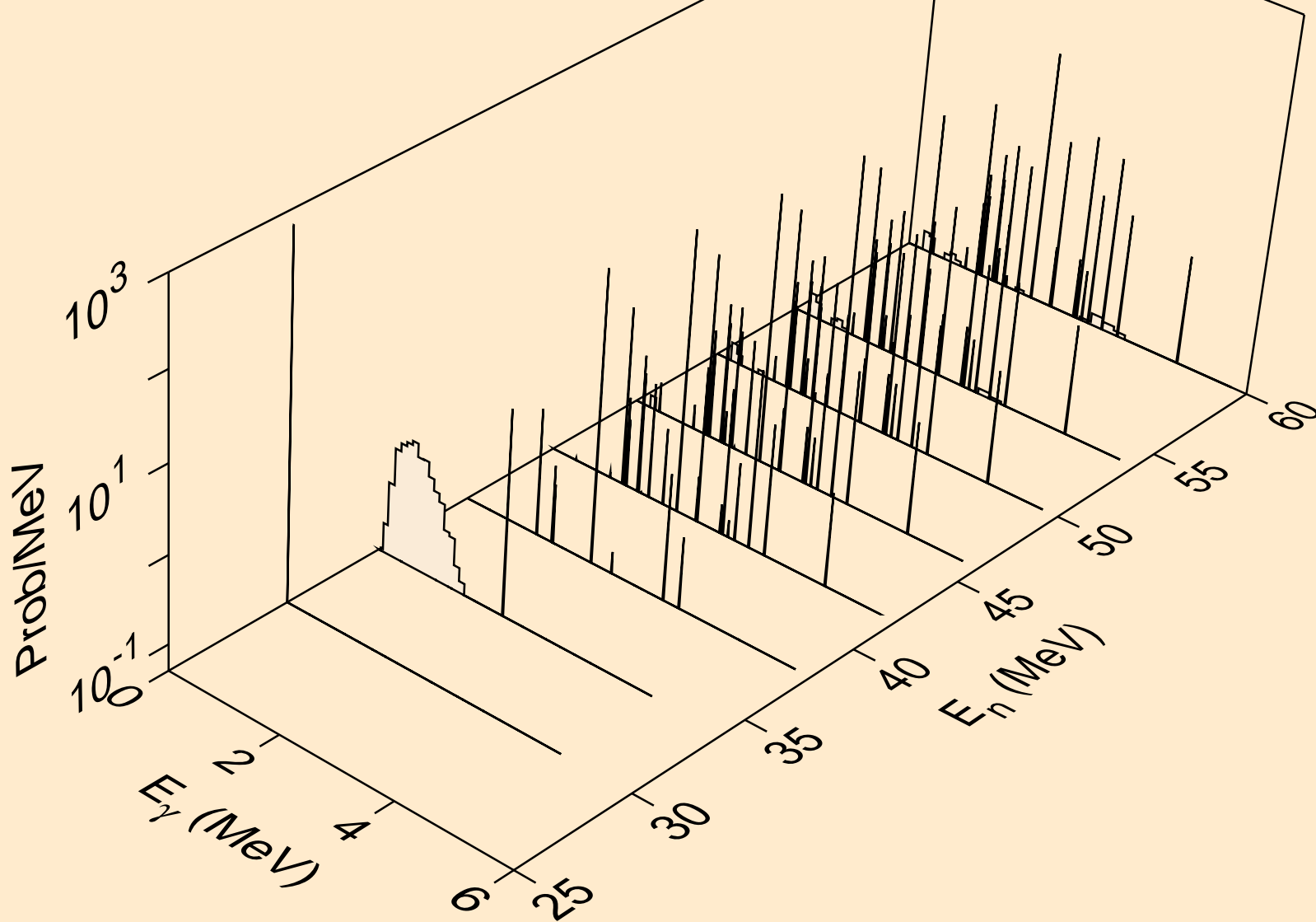

16-S-34 FOR FENDL-3.1 FROM TENDL-2010 WITH NJOY2012.50+
Photon emission for (n,3n)he3

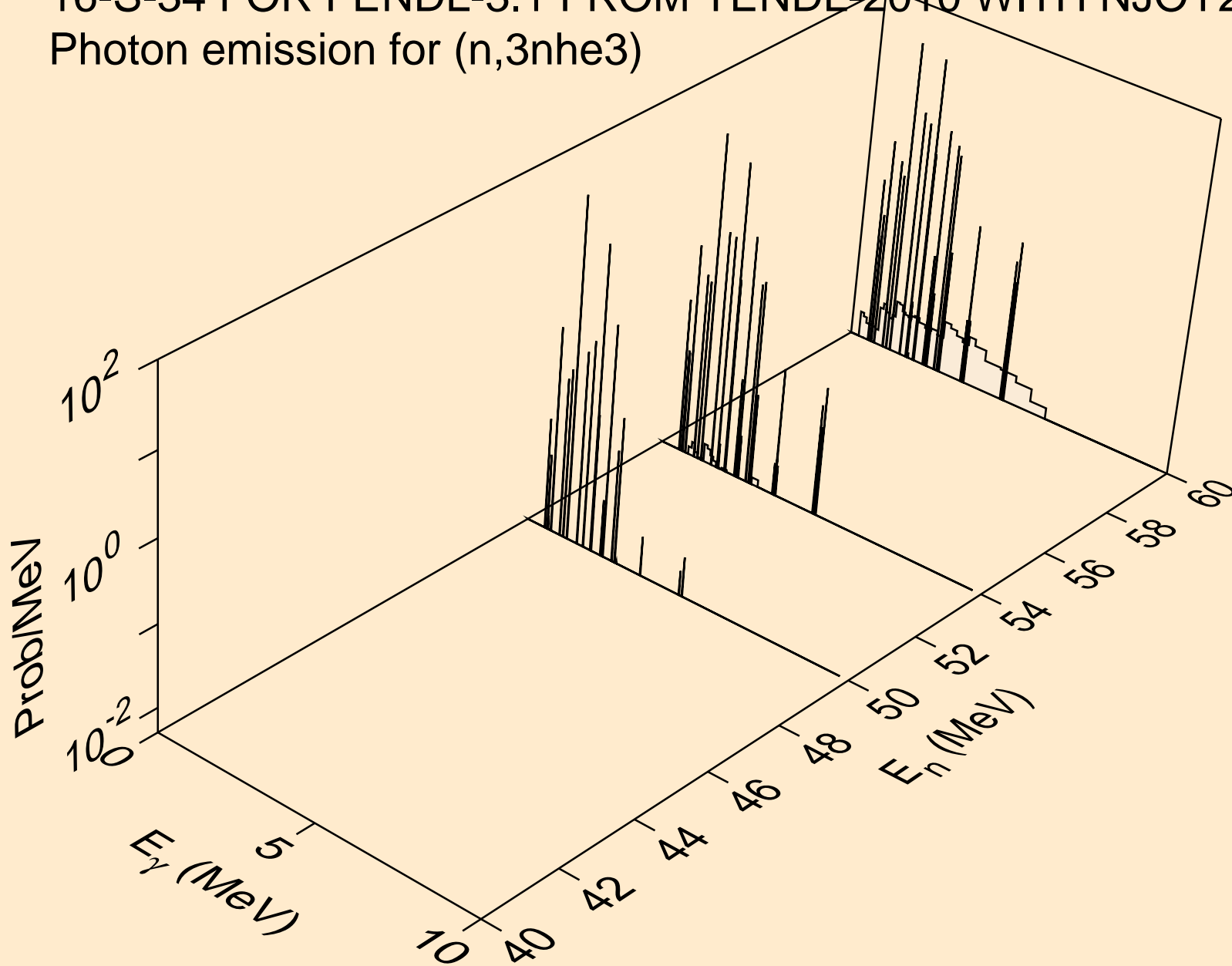

16-S-34 FOR FENDL-3.1 FROM TENDL-2010 WITH NJOY2012.50+
Photon emission for (n,4n)he3

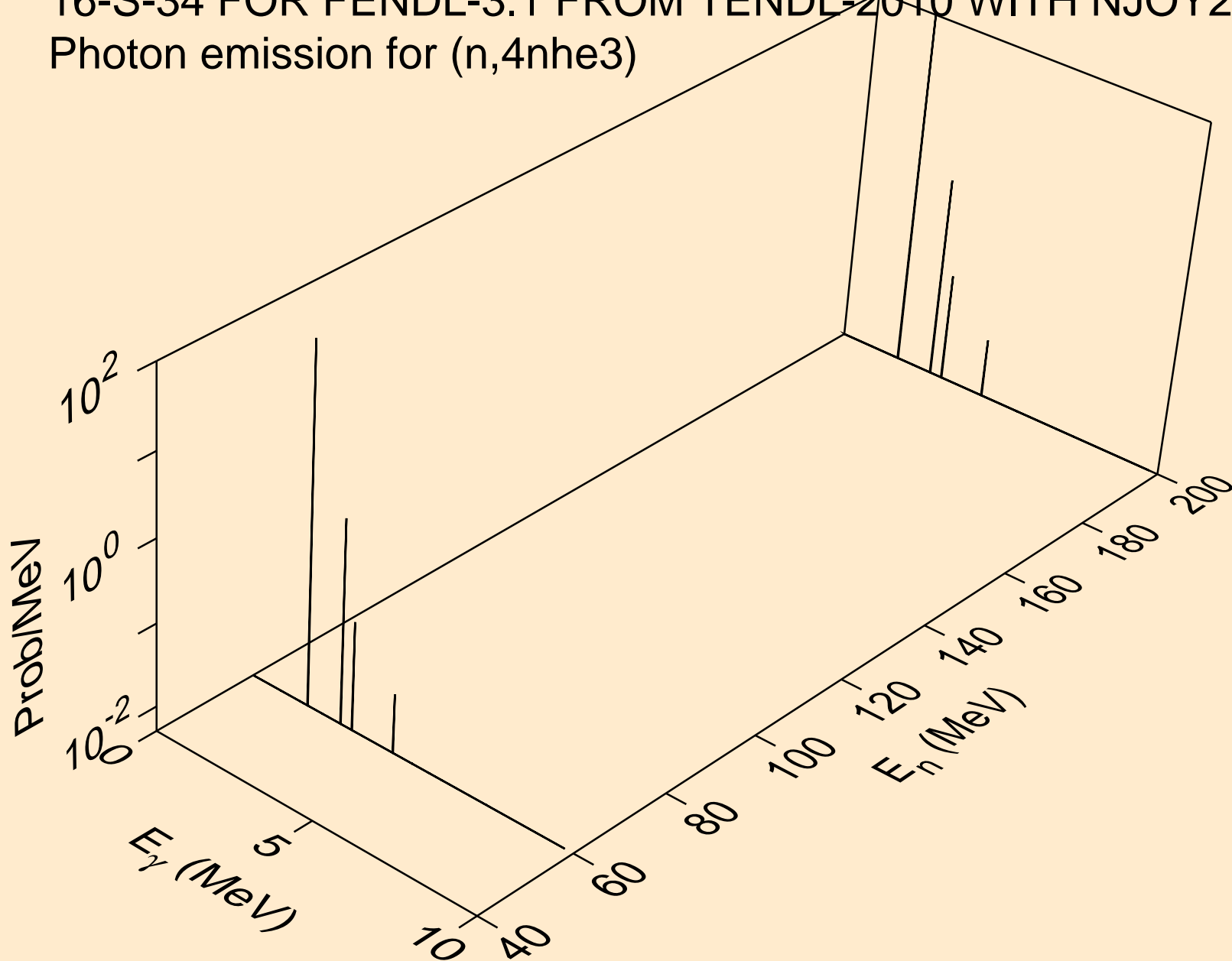

16-S-34 FOR FENDL-3.1 FROM TENDL-2010 WITH NJOY2012.50+
Photon emission for (n,3n2p)

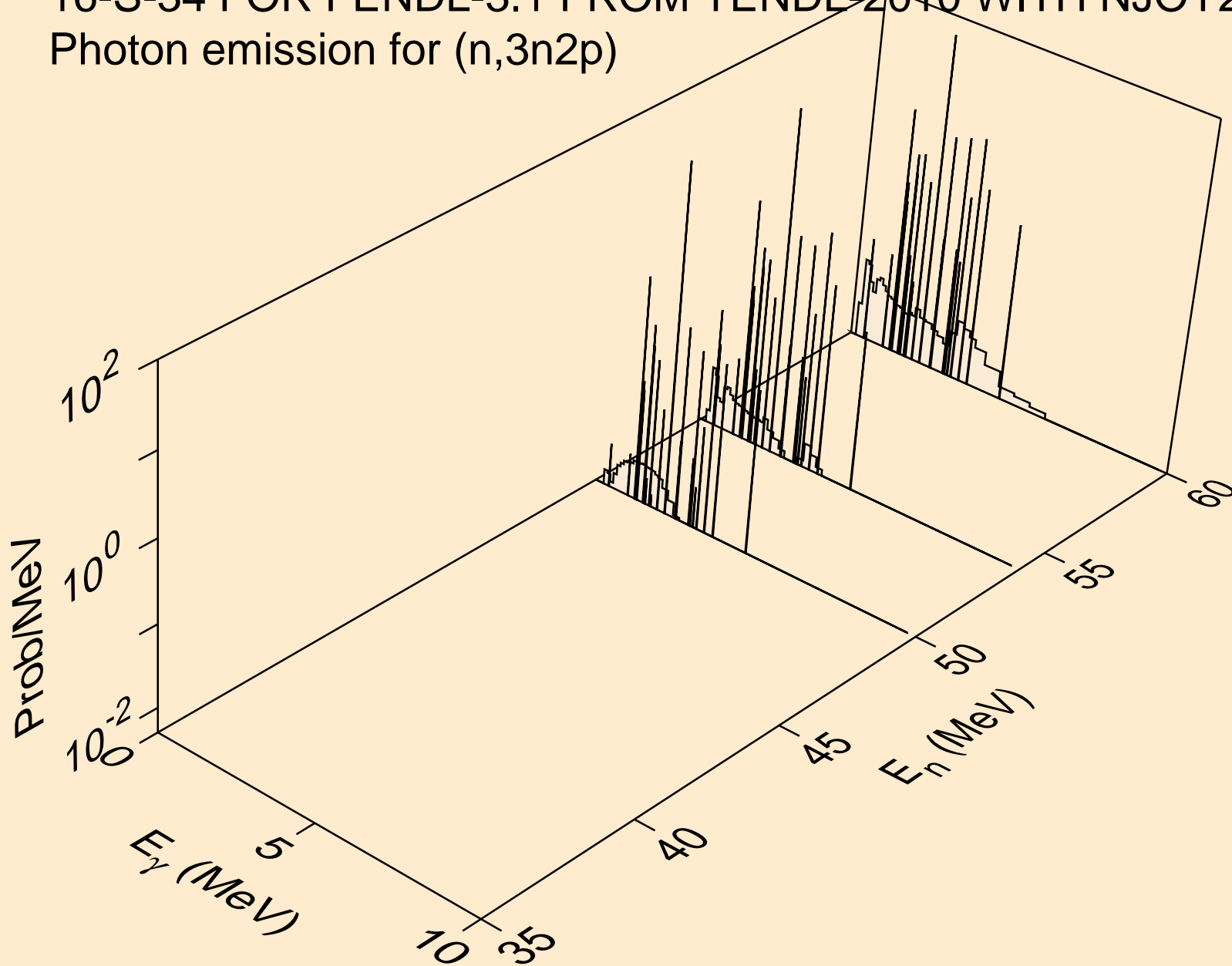

16-S-34 FOR FENDL-3.1 FROM TENDL-2010 WITH NJOY2012.50+
Photon emission for (n,3n2a)

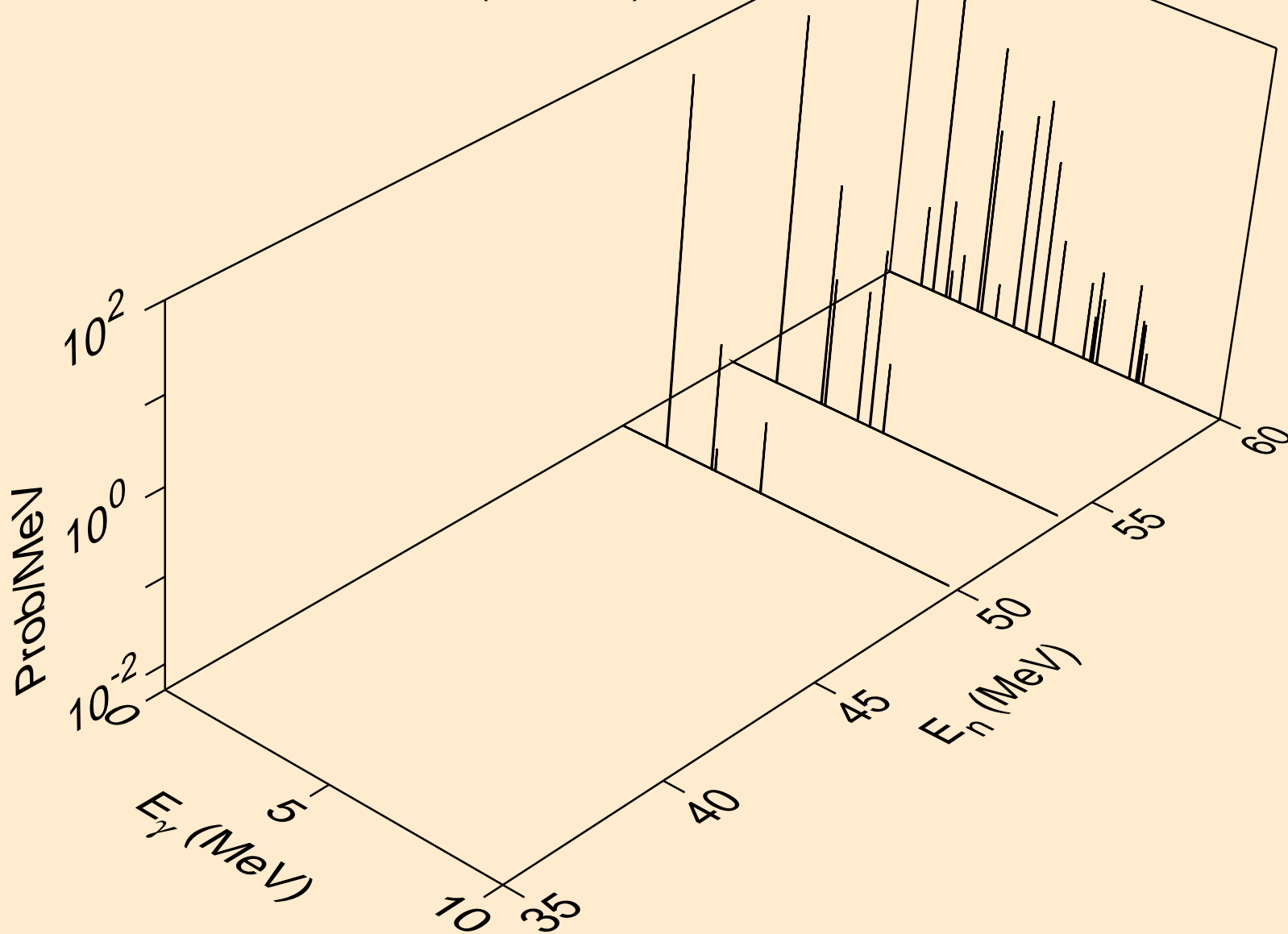

16-S-34 FOR FENDL-3.1 FROM TENDL-2010 WITH NJOY2012.50+
Photon emission for (n,3npa)

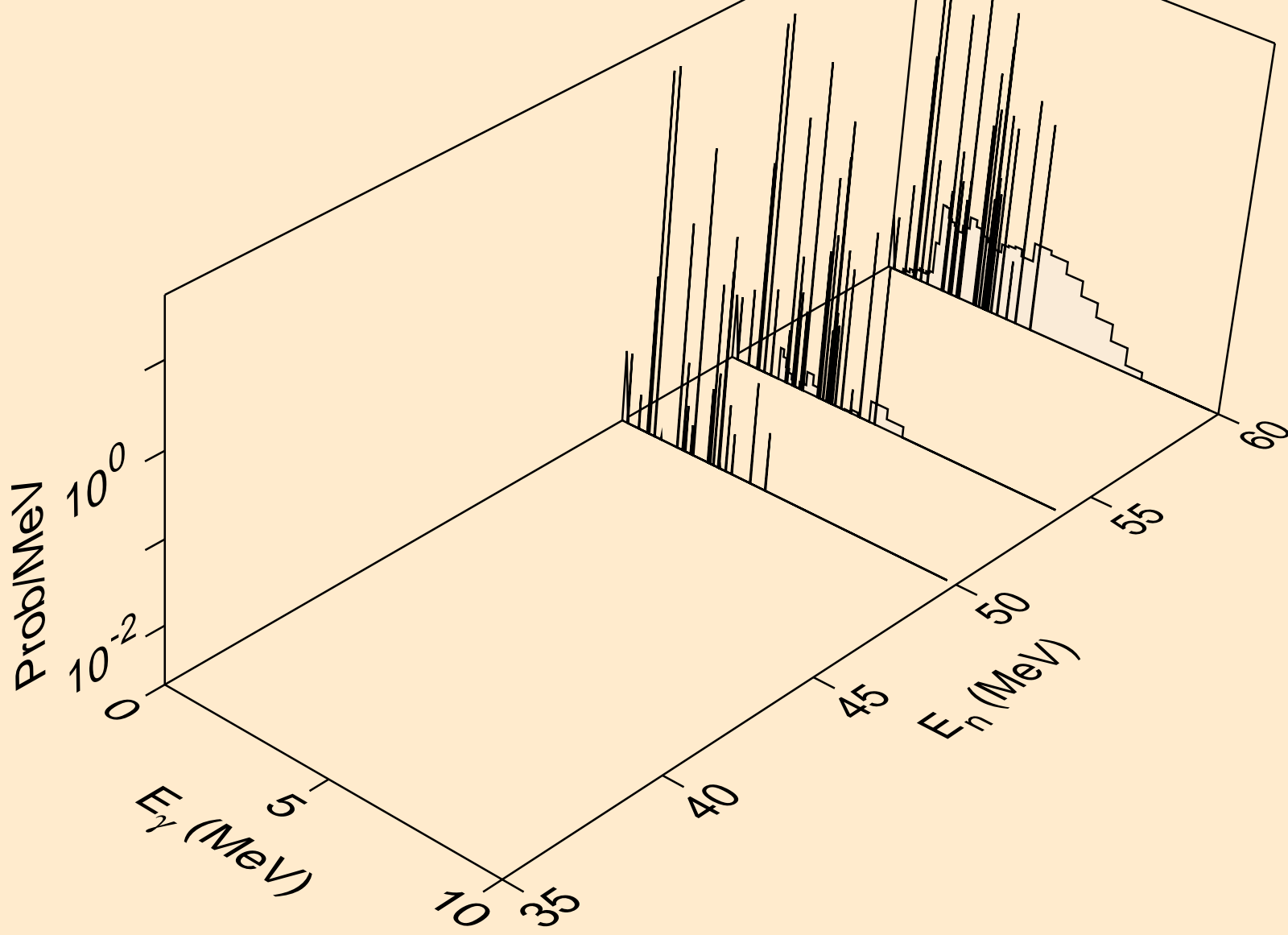

16-S-34 FOR FENDL-3.1 FROM TENDL-2010 WITH NJOY2012.50+
Photon emission for (n,dt)

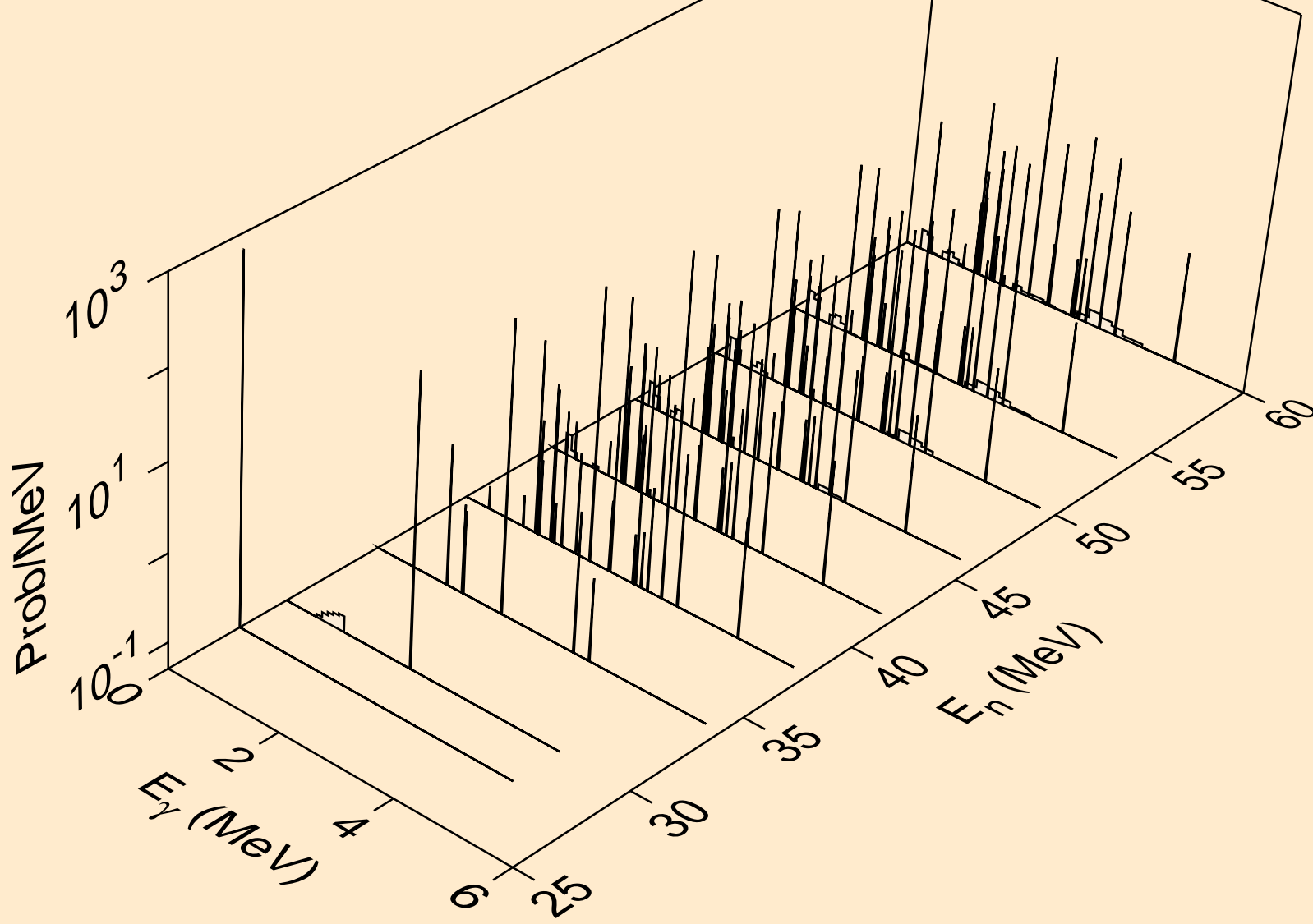

16-S-34 FOR FENDL-3.1 FROM TENDL-2010 WITH NJOY2012.50+
Photon emission for (n,npd)

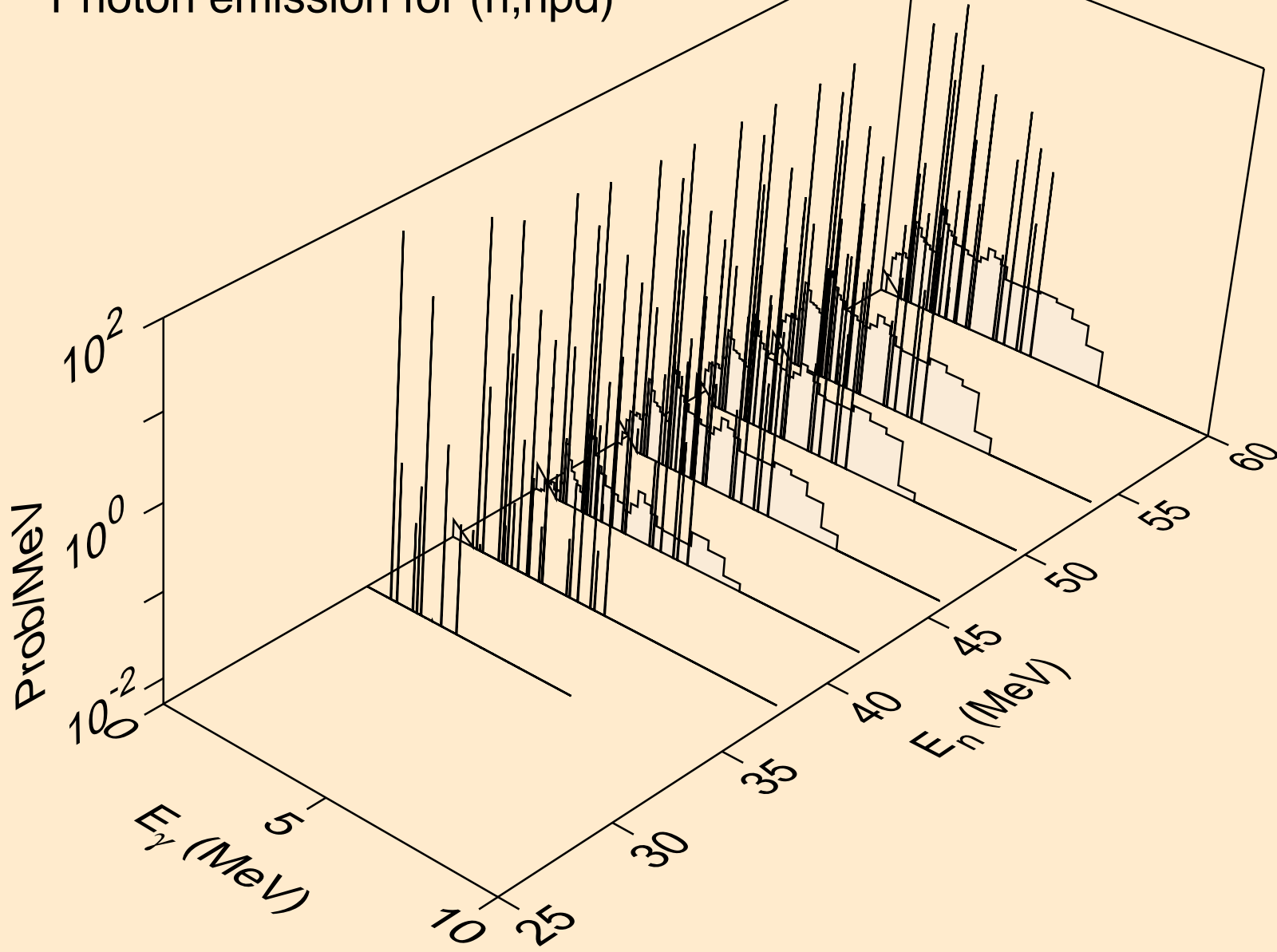

16-S-34 FOR FENDL-3.1 FROM TENDL-2010 WITH NJOY2012.50+
Photon emission for (n,npt)

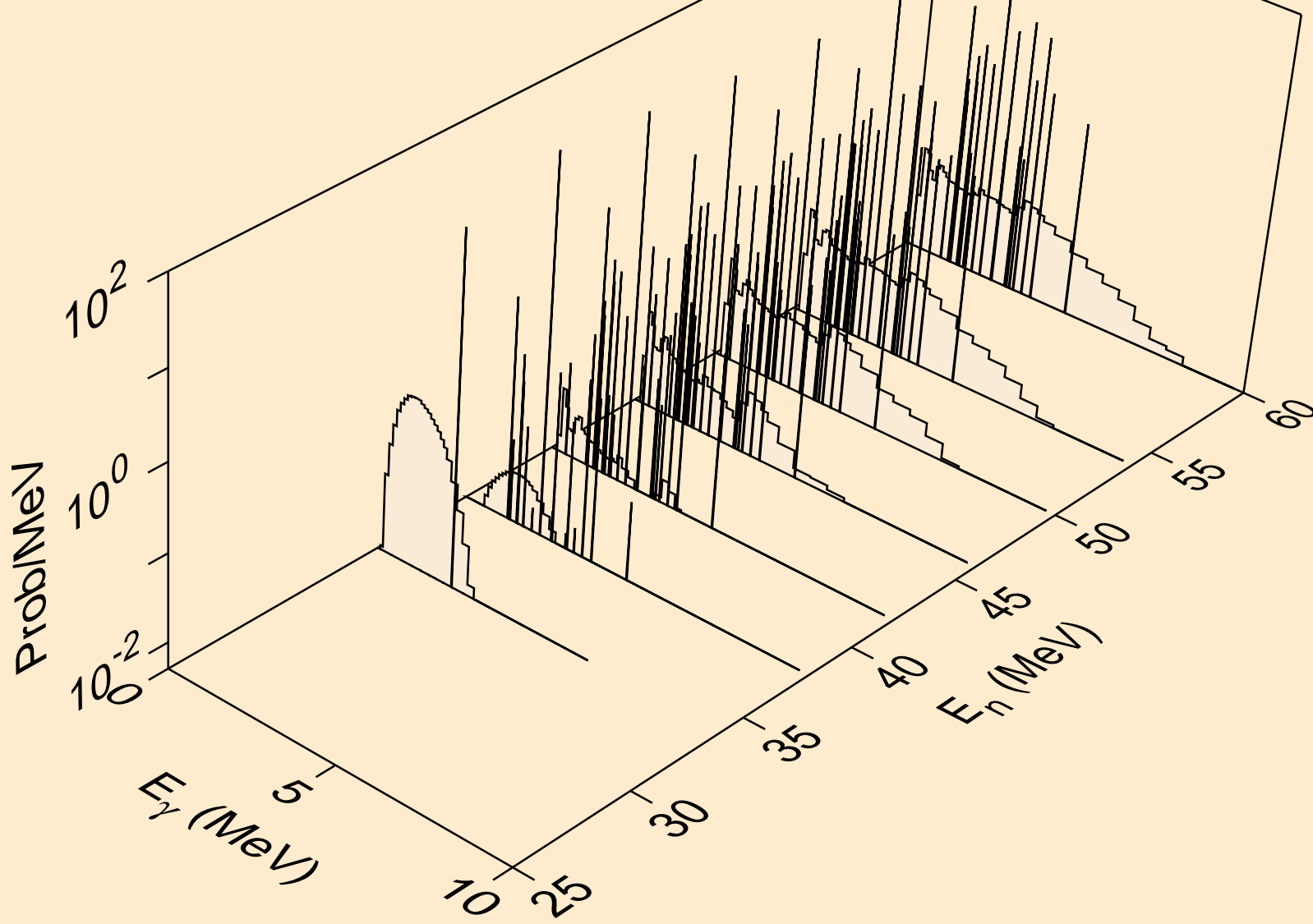

16-S-34 FOR FENDL-3.1 FROM TENDL-2010 WITH NJOY2012.50+
Photon emission for (n,ndt)

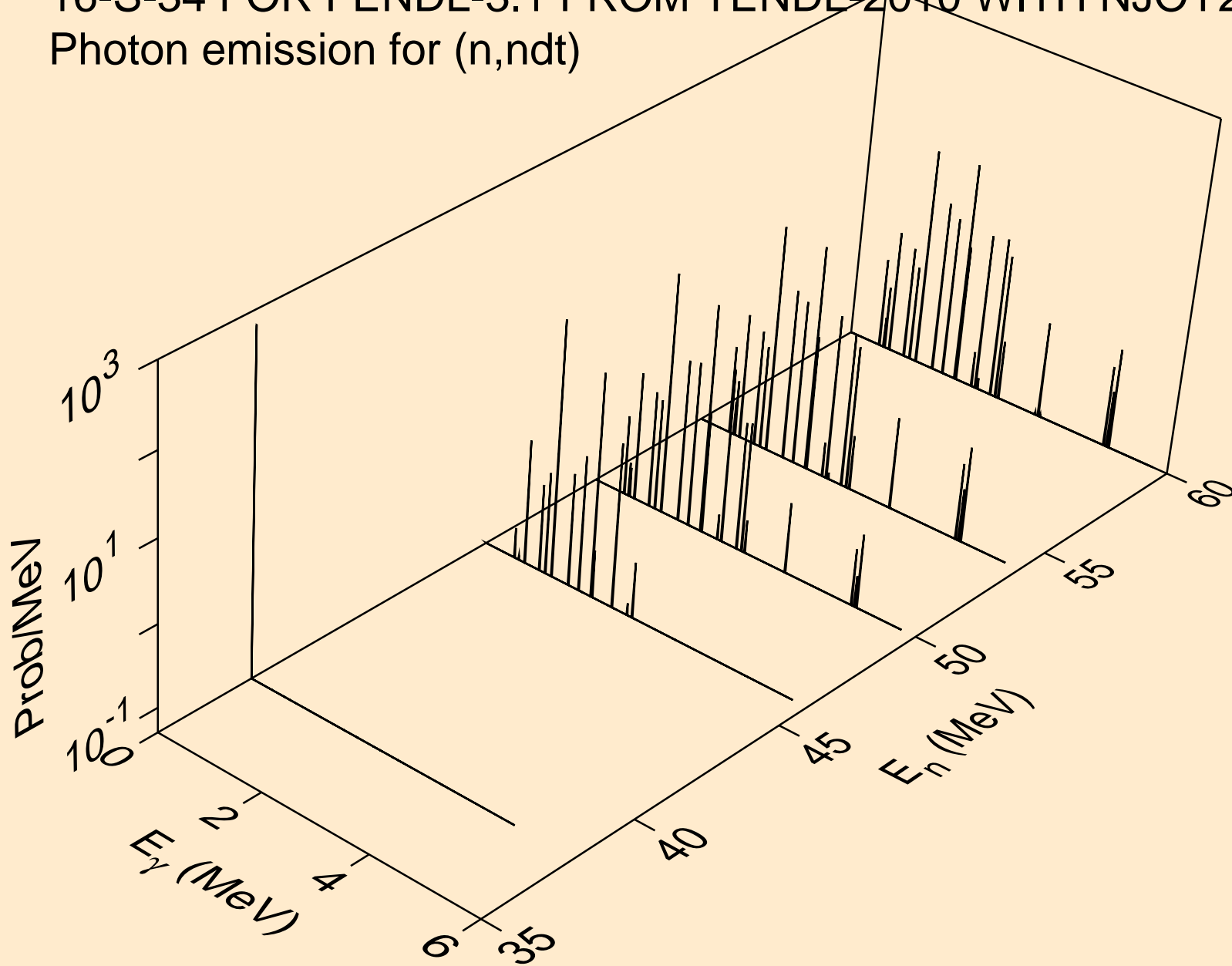

16-S-34 FOR FENDL-3.1 FROM TENDL-2010 WITH NJOY2012.50+
Photon emission for (n,nphe3)

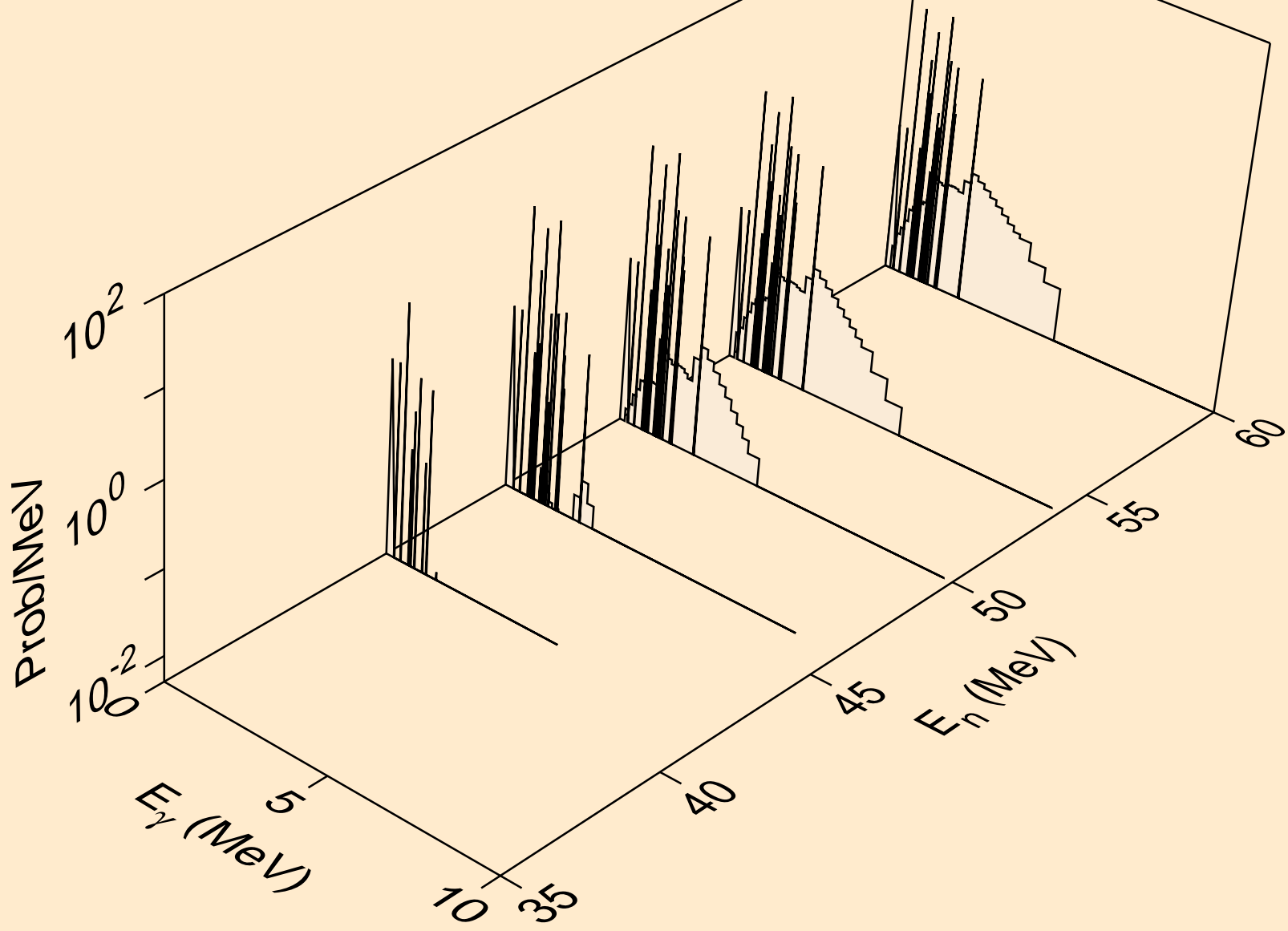

16-S-34 FOR FENDL-3.1 FROM TENDL-2010 WITH NJOY2012.50+
Photon emission for (n,ndhe3)

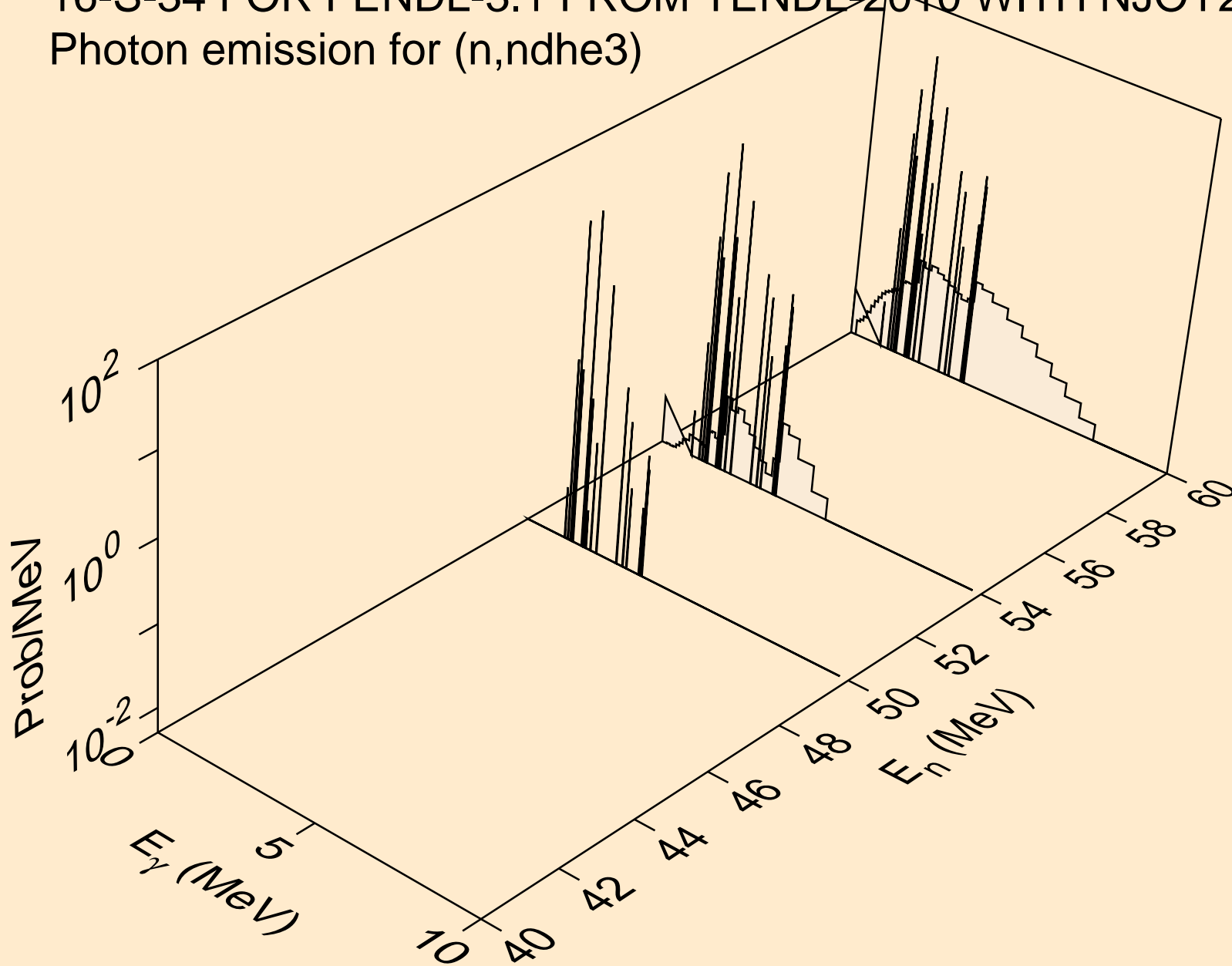

16-S-34 FOR FENDL-3.1 FROM TENDL-2010 WITH NJOY2012.50+
Photon emission for (n,nthe3)

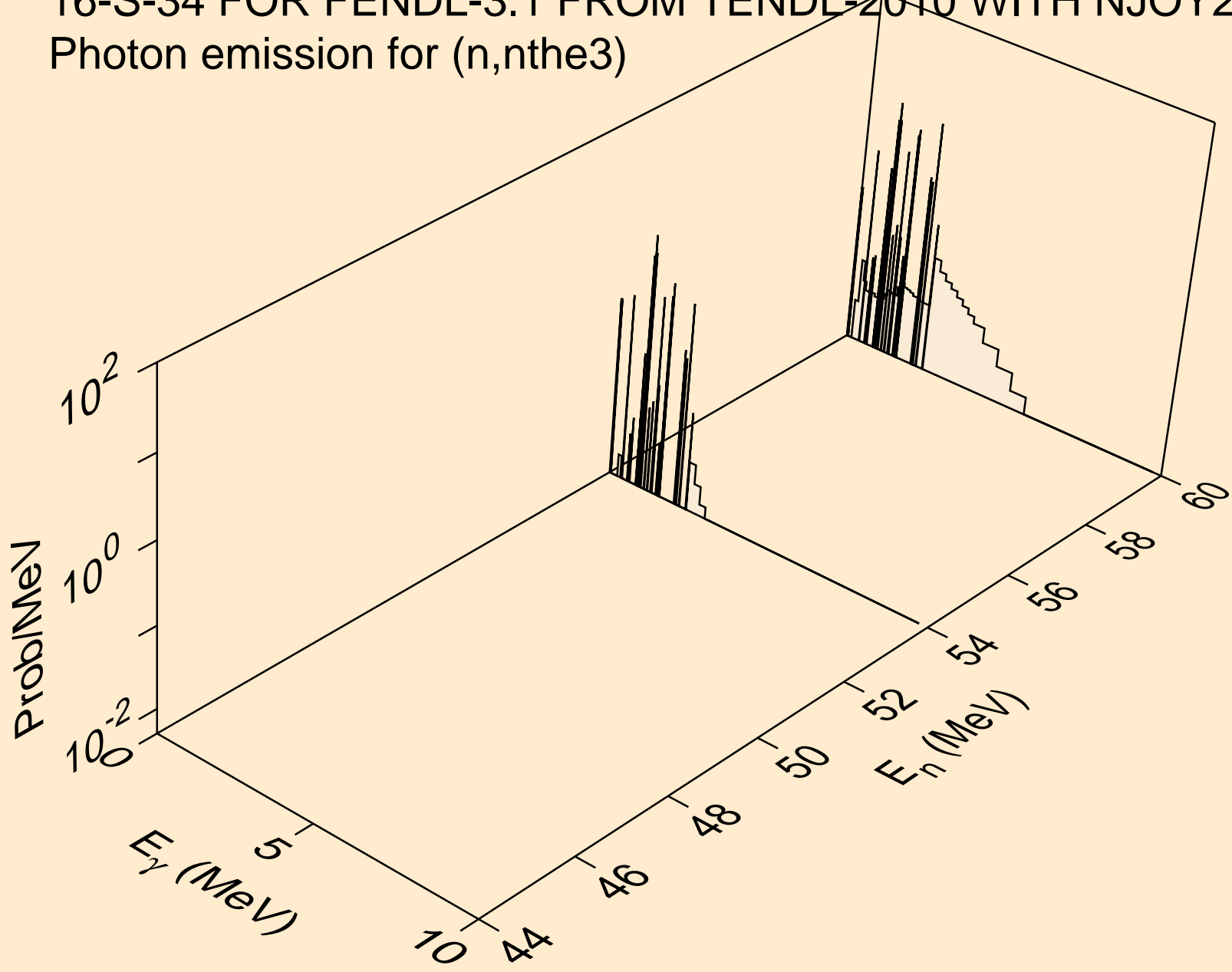

16-S-34 FOR FENDL-3.1 FROM TENDL-2010 WITH NJOY2012.50+
Photon emission for (n,nta)

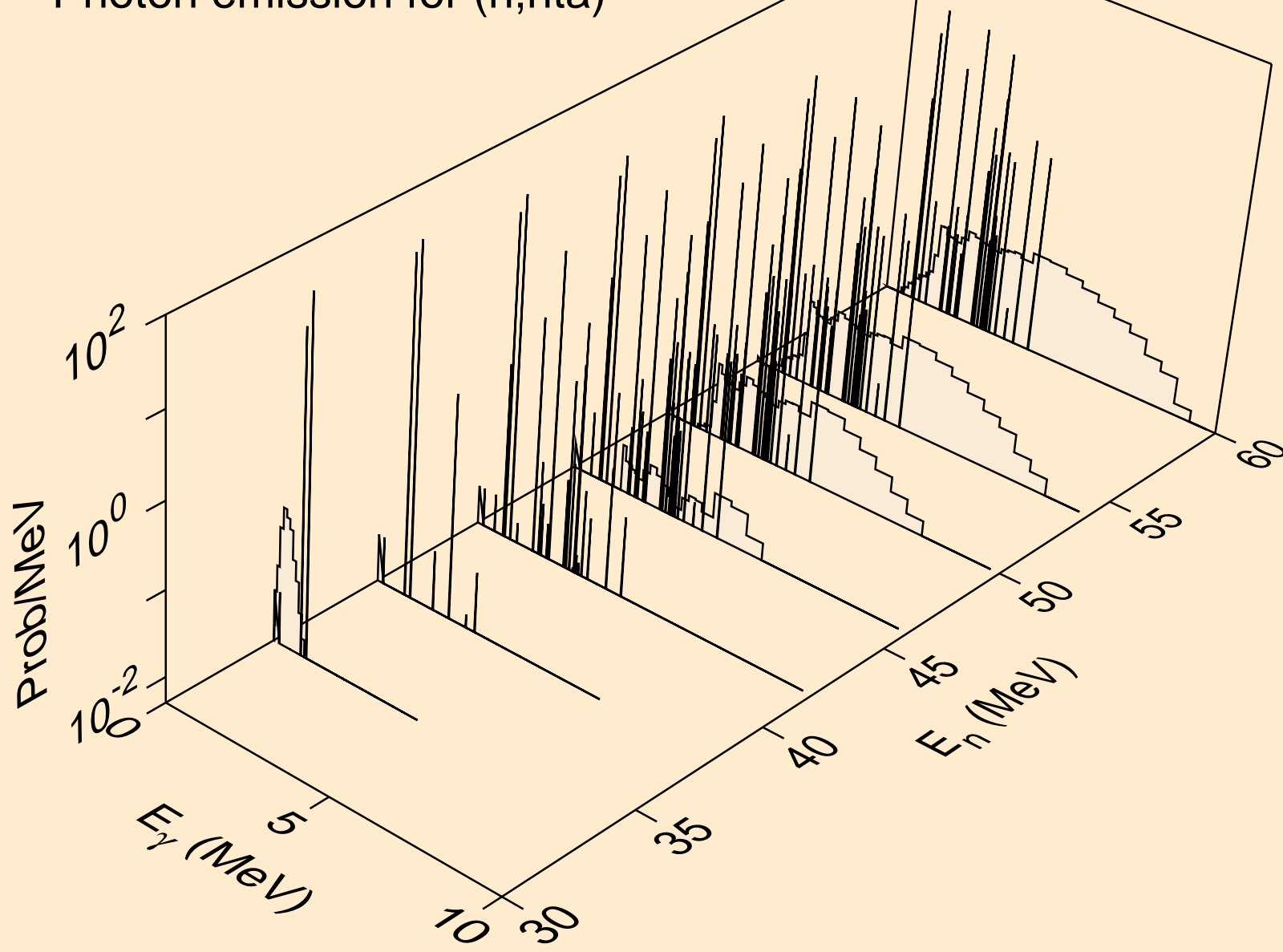

16-S-34 FOR FENDL-3.1 FROM TENDL-2010 WITH NJOY2012.50+
Photon emission for (n,2n2p)

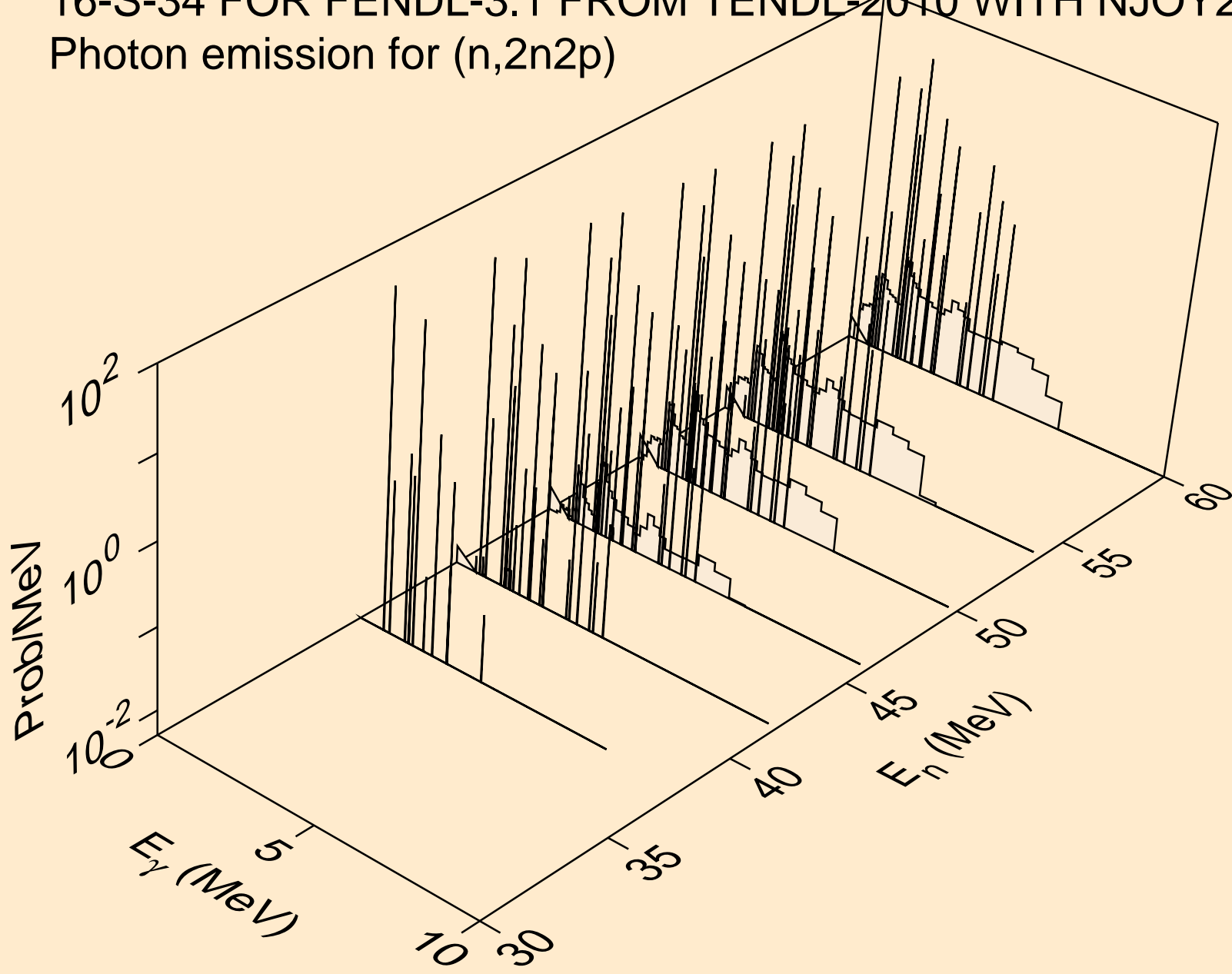

16-S-34 FOR FENDL-3.1 FROM TENDL-2010 WITH NJOY2012.50+
Photon emission for (n,phe3)

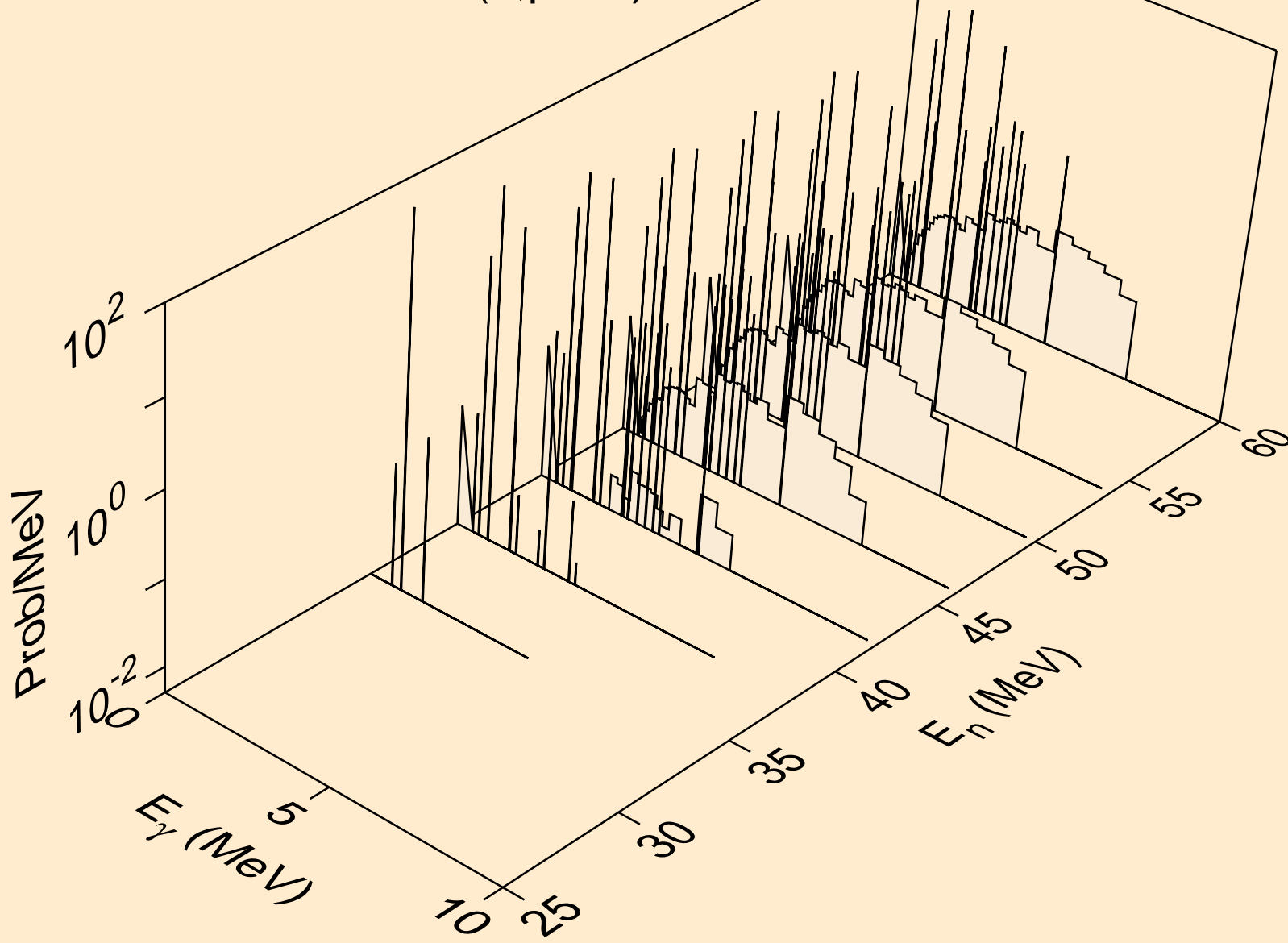

16-S-34 FOR FENDL-3.1 FROM TENDL-2010 WITH NJOY2012.50+
Photon emission for (n,dhe3)

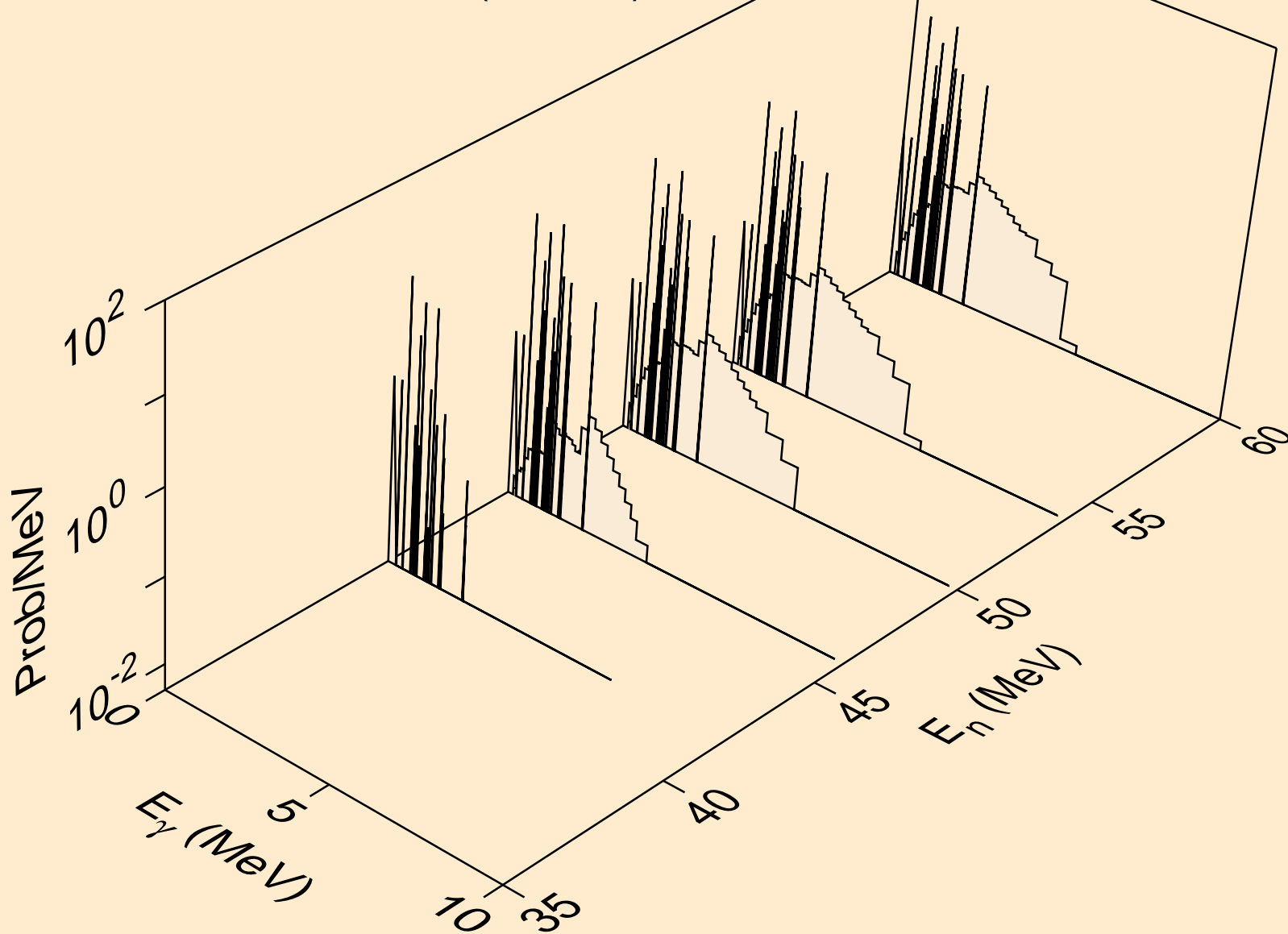

16-S-34 FOR FENDL-3.1 FROM TENDL-2010 WITH NJOY2012.50+
Photon emission for (n,he3a)

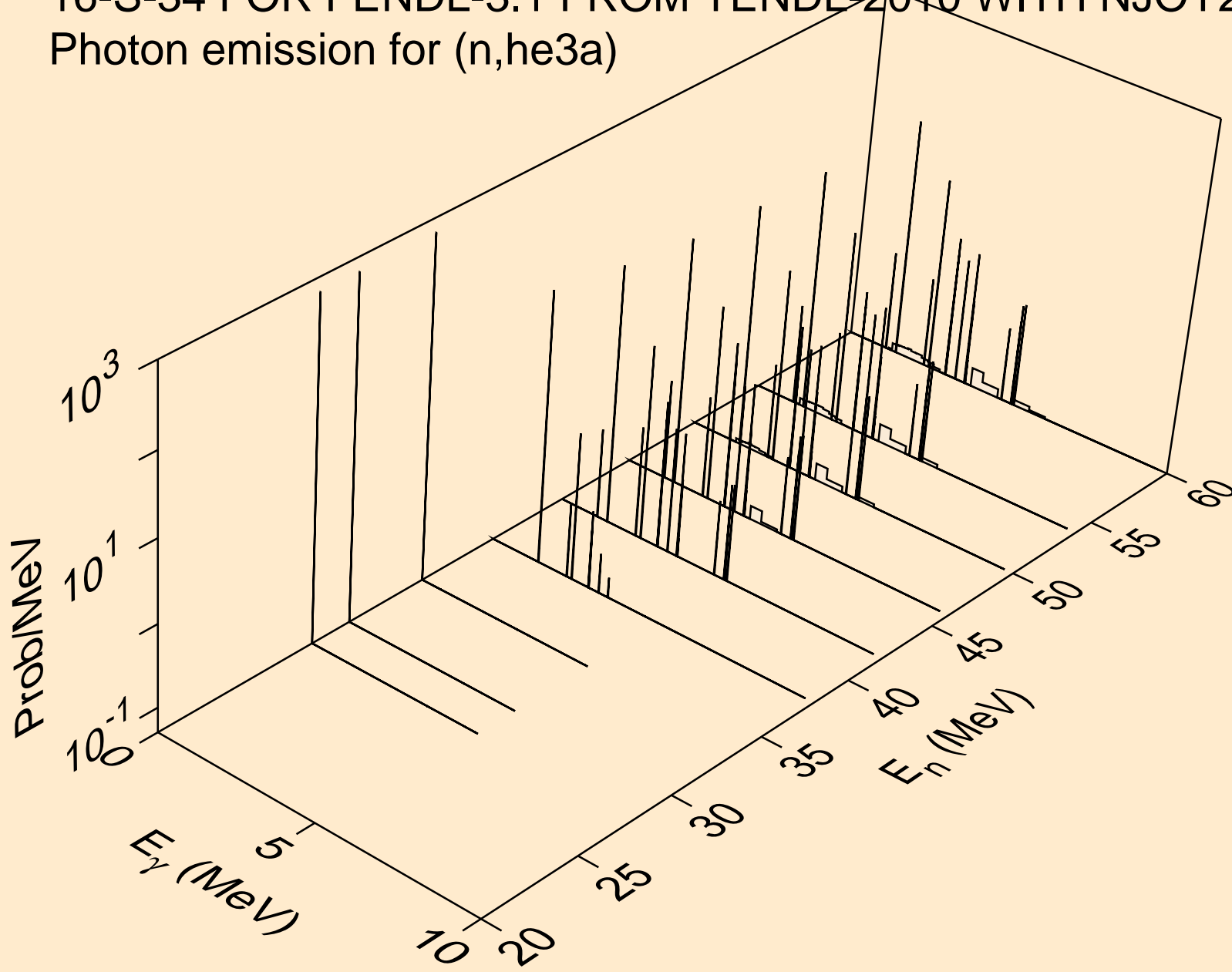

16-S-34 FOR FENDL-3.1 FROM TENDL-2010 WITH NJOY2012.50+
Photon emission for (n,4n2p)

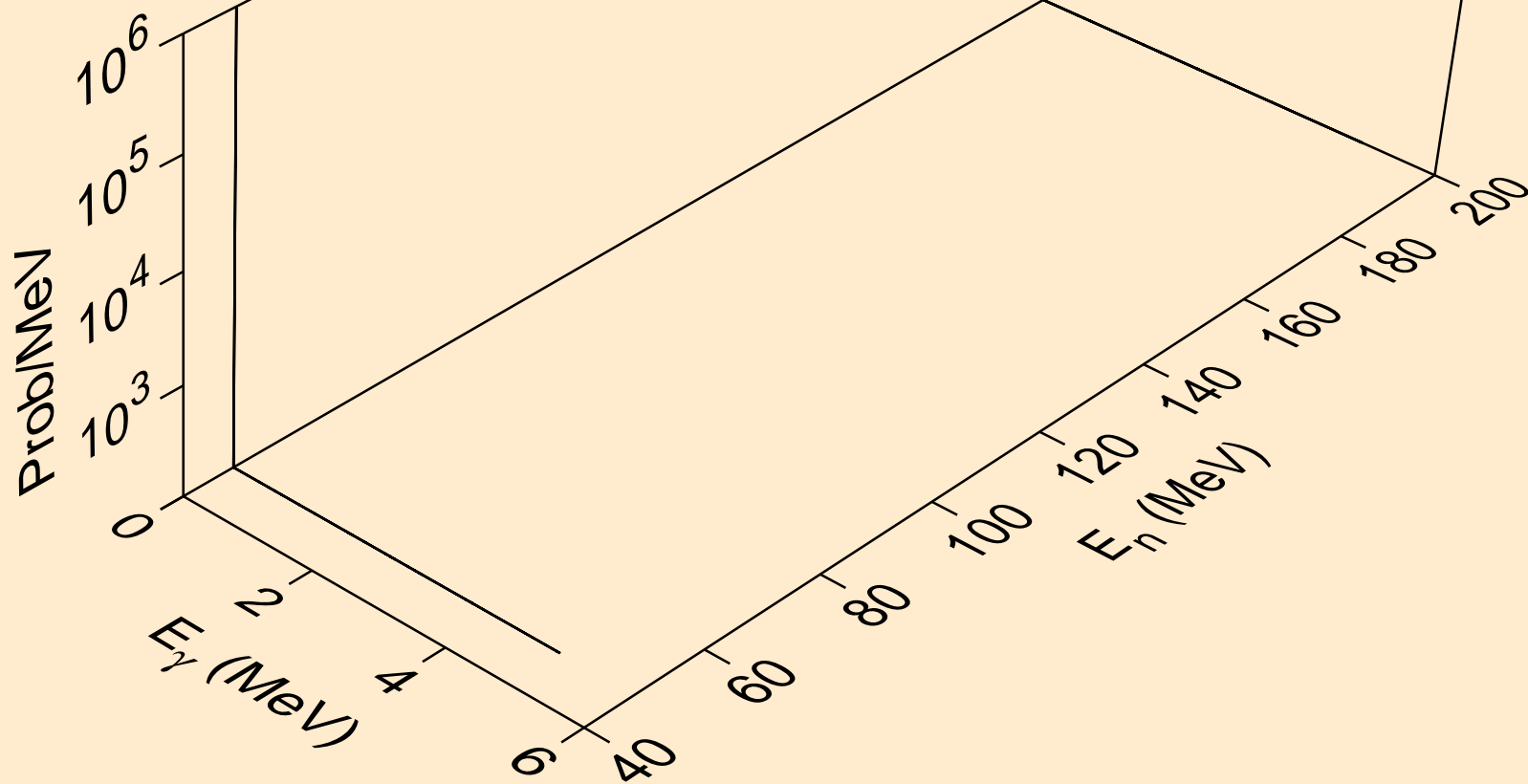

16-S-34 FOR FENDL-3.1 FROM TENDL-2010 WITH NJOY2012.50+
Photon emission for (n,4npa)

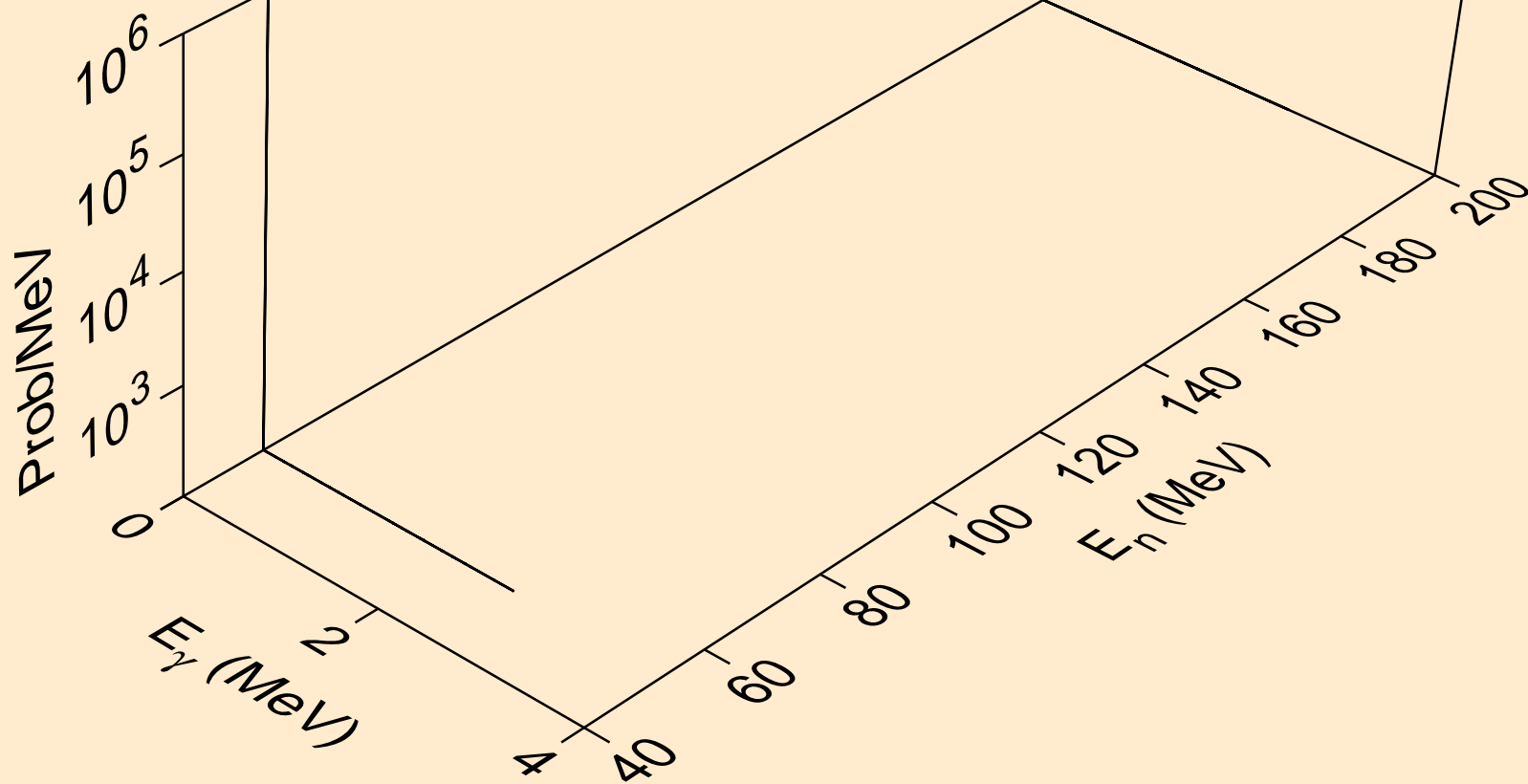

16-S-34 FOR FENDL-3.1 FROM TENDL-2010 WITH NJOY2012.50+
Photon emission for (n,3p)

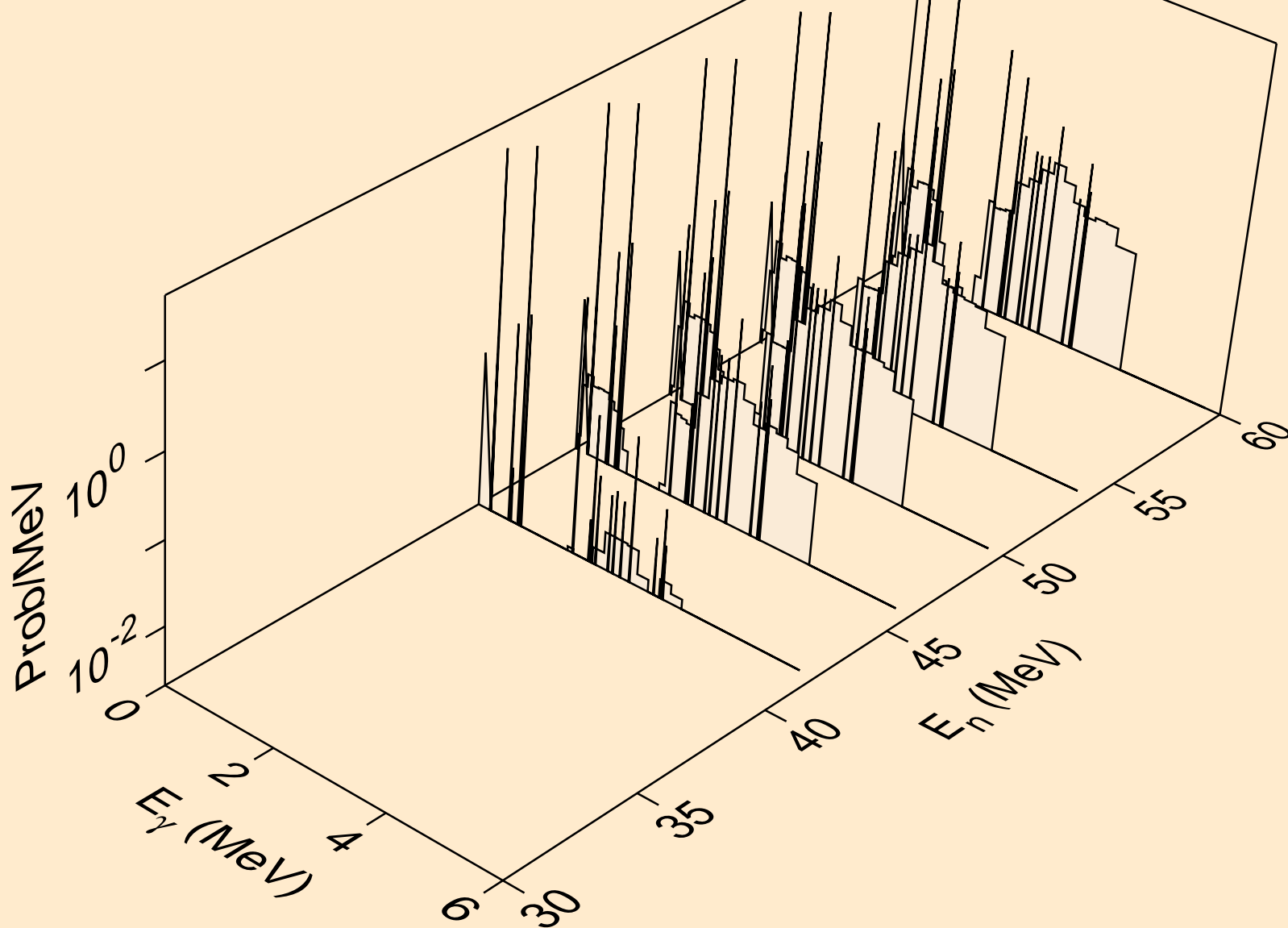

16-S-34 FOR FENDL-3.1 FROM TENDL-2010 WITH NJOY2012.50+
Photon emission for (n,n3p)

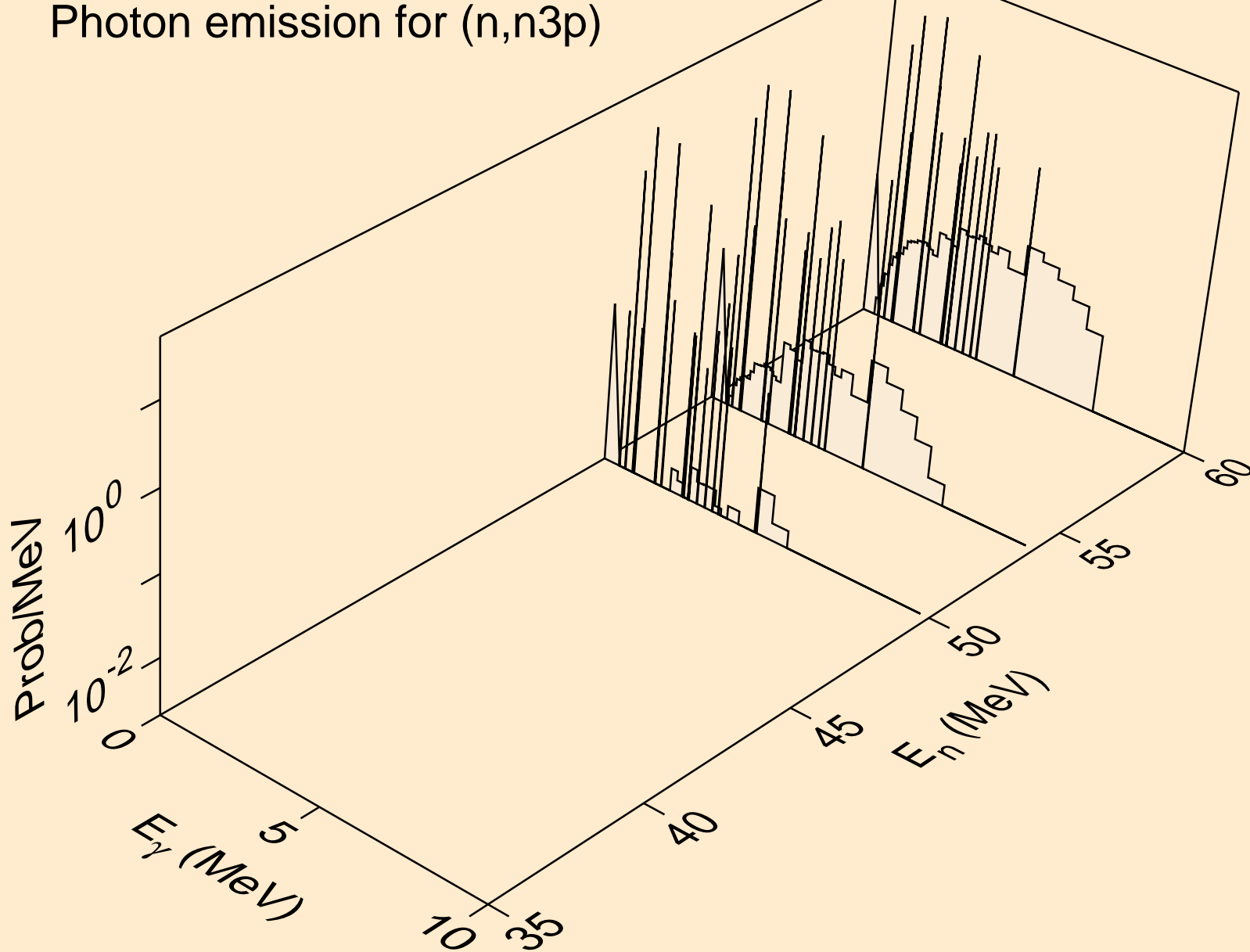

16-S-34 FOR FENDL-3.1 FROM TENDL-2010 WITH NJOY2012.50+
Photon emission for (n,3n2pa)

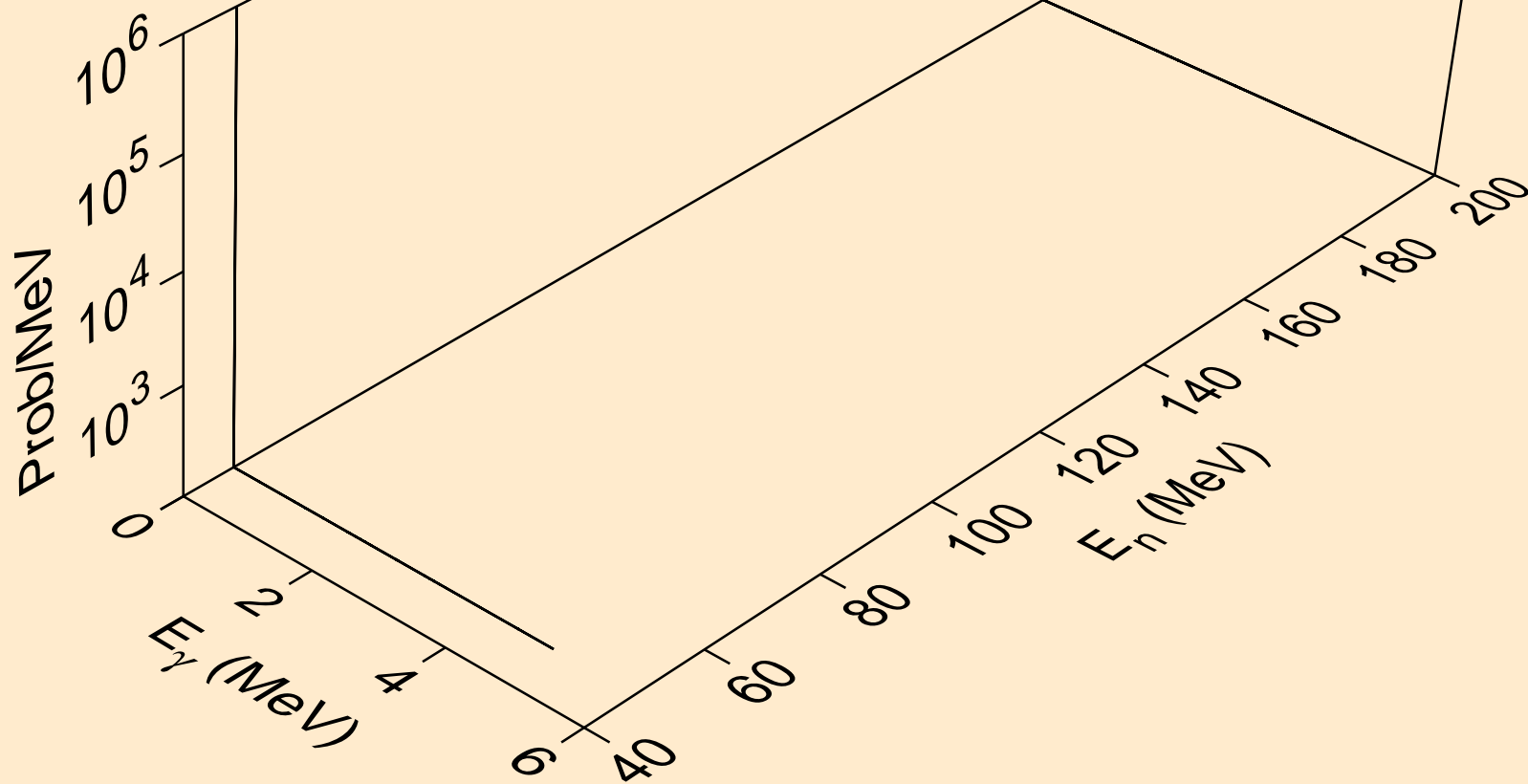

16-S-34 FOR FENDL-3.1 FROM TENDL-2010 WITH NJOY2012.50+
thermal capture photon spectrum

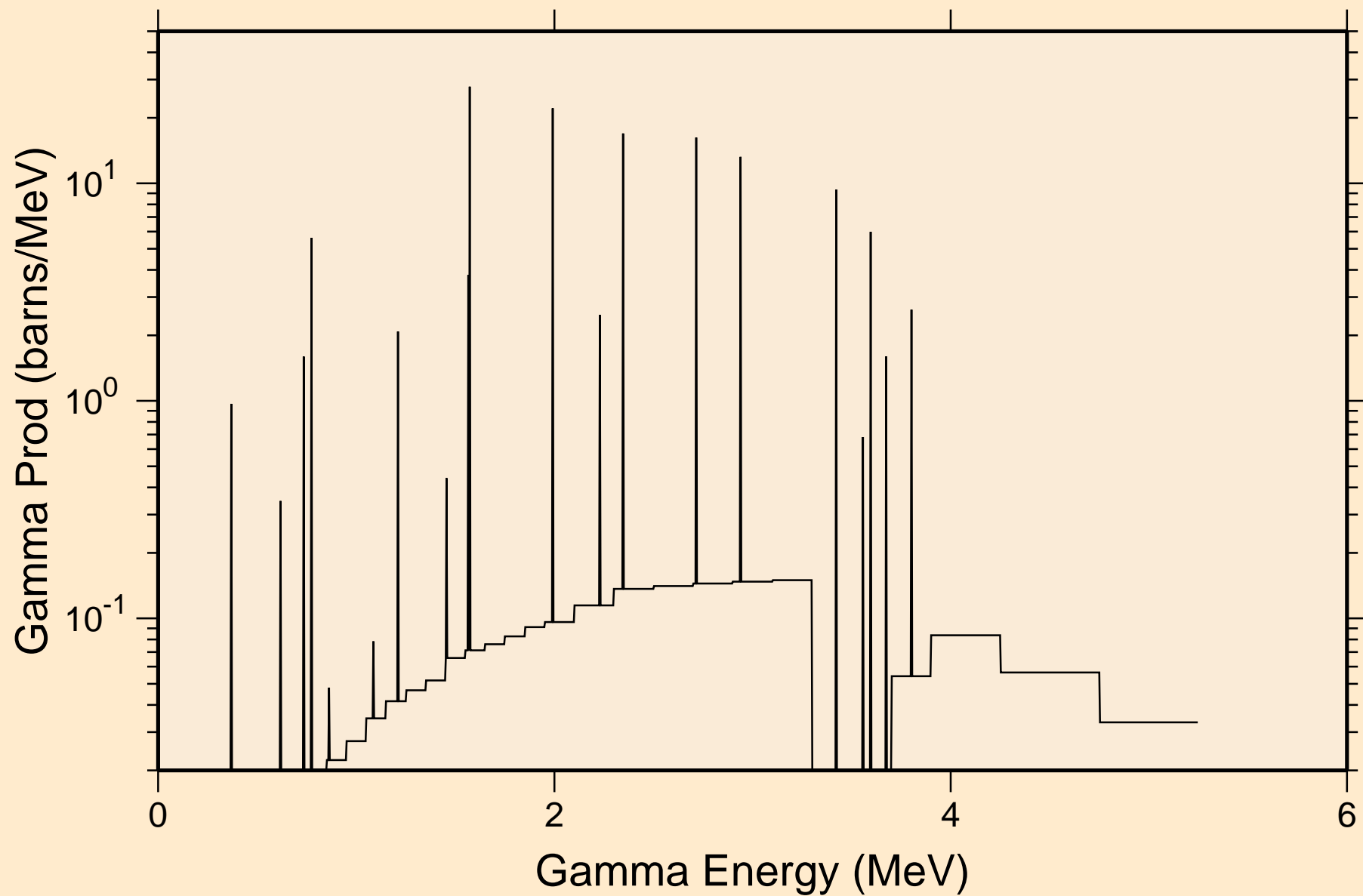

16-S-34 FOR FENDL-3.1 FROM TENDL-2010 WITH NJOY2012.50+
14 MeV photon spectrum

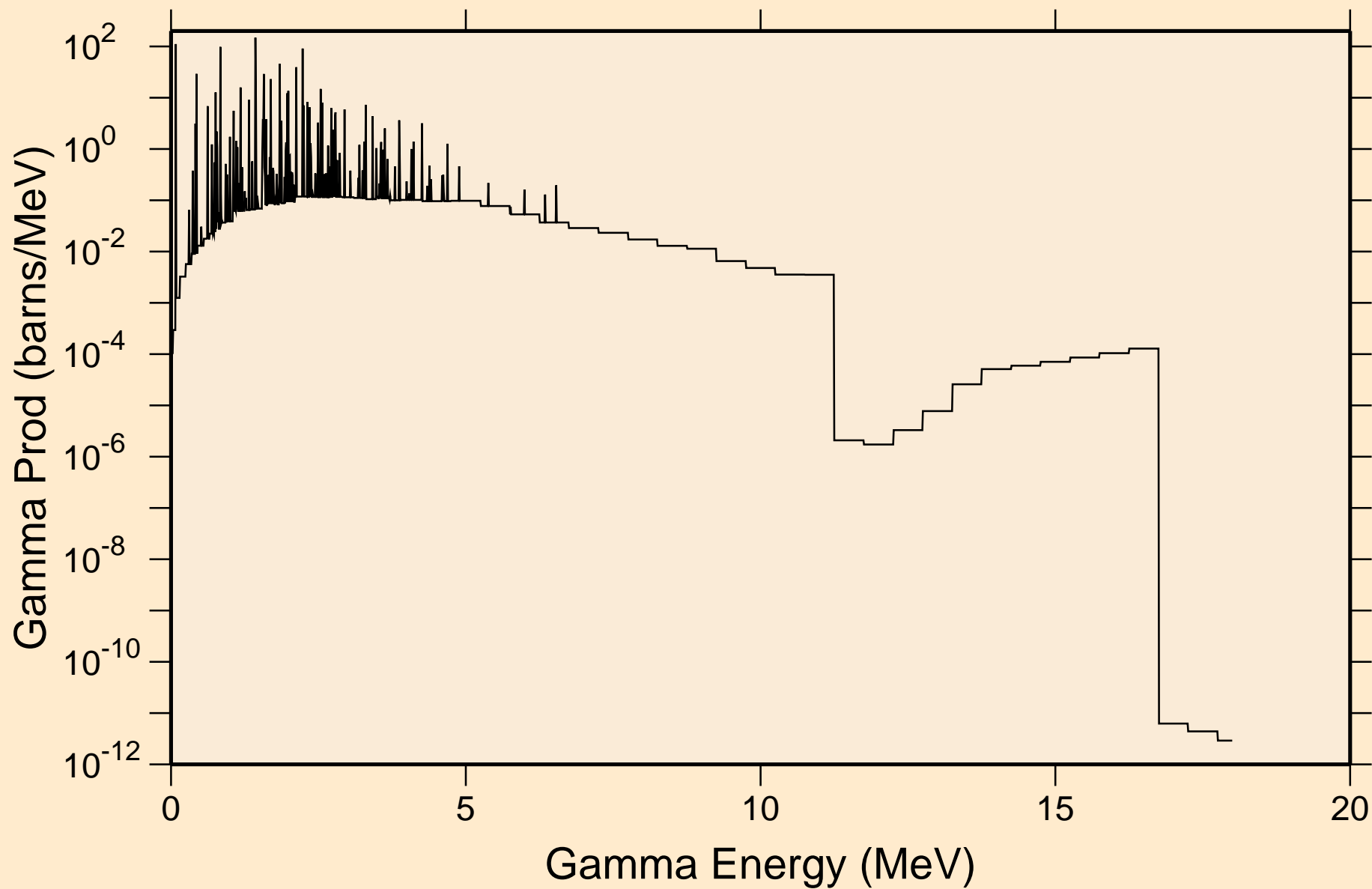

16-S-34 FOR FENDL-3.1 FROM TENDL-2010 WITH NJOY2012.50+

Particle heating contributions

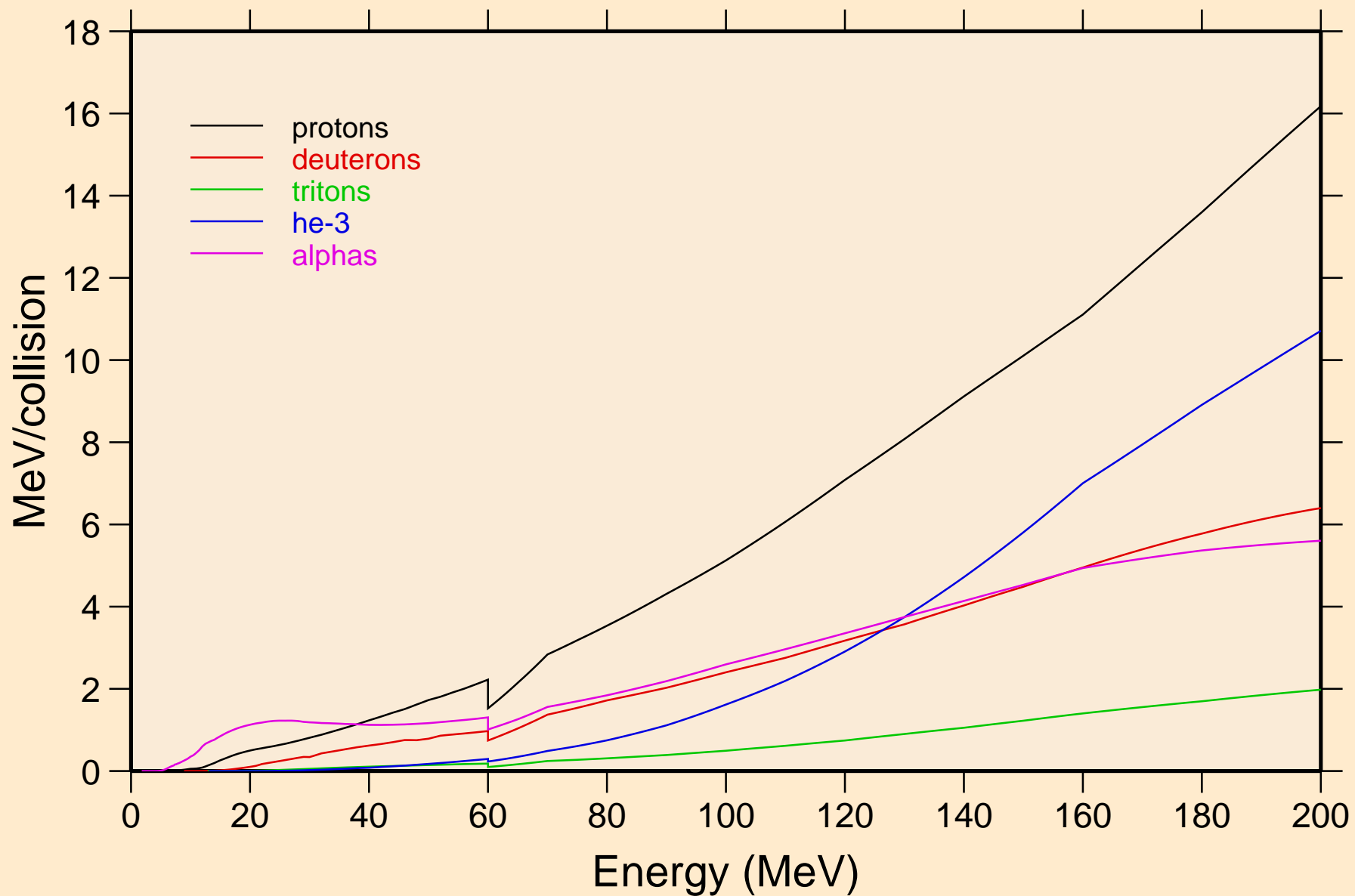

16-S-34 FOR FENDL-3.1 FROM TENDL-2010 WITH NJOY2012.50+

Recoil Heating

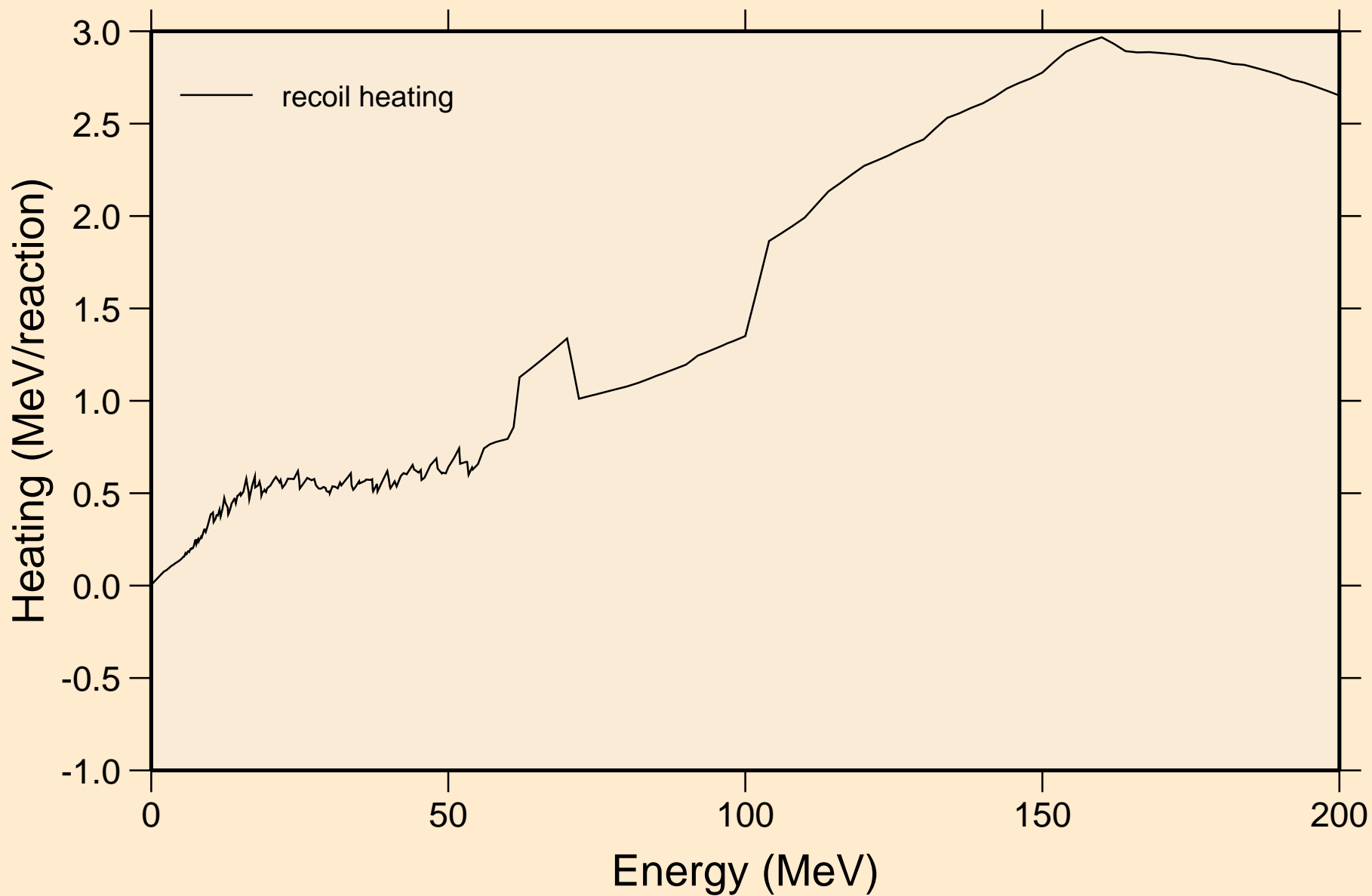

16-S-34 FOR FENDL-3.1 FROM TENDL-2010 WITH NJOY2012.50+

Particle production cross sections

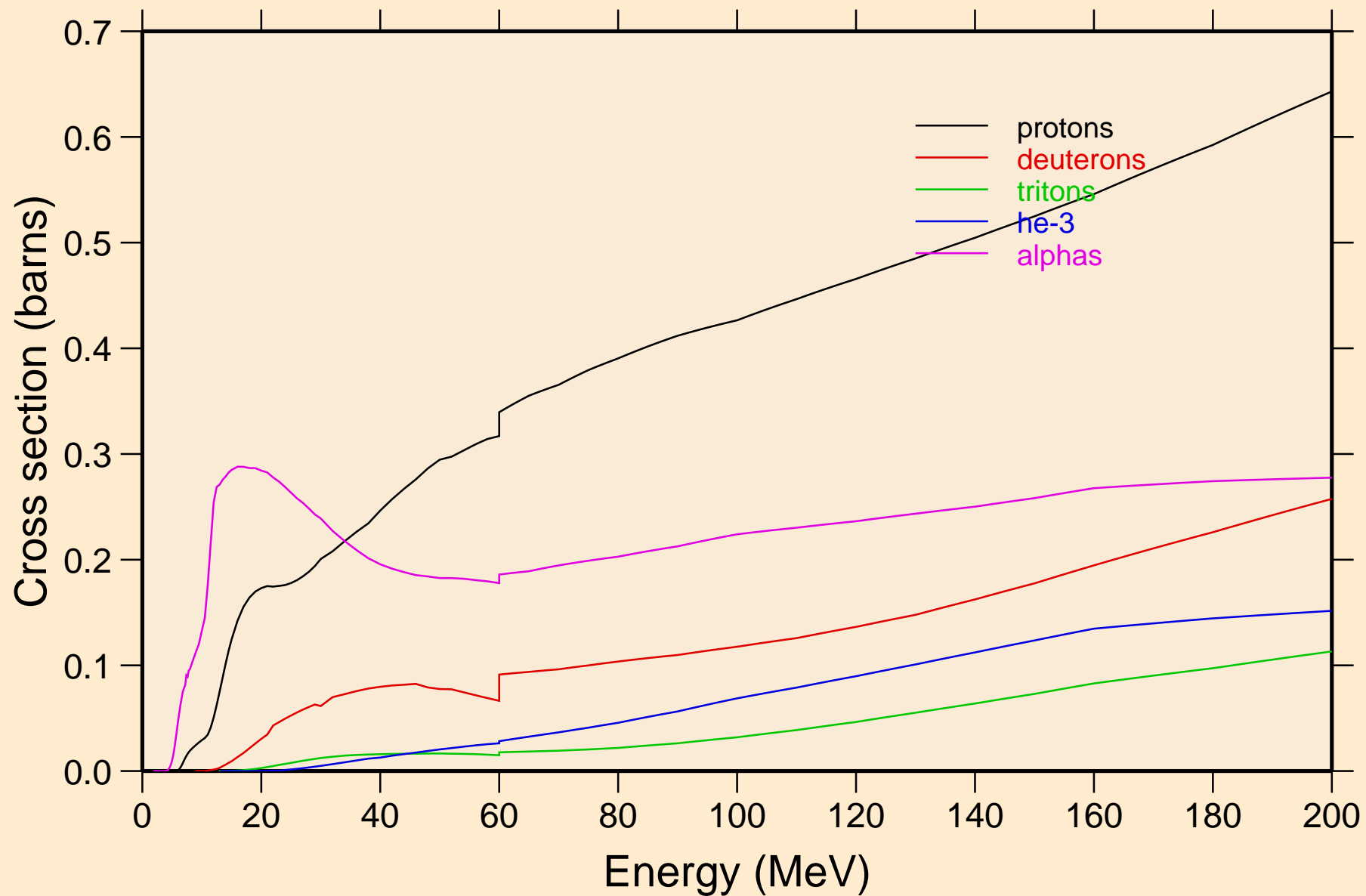

16-S-34 FOR FENDL-3.1 FROM TENDL-2010 WITH NJOY2012.50+
protons from (n,x)

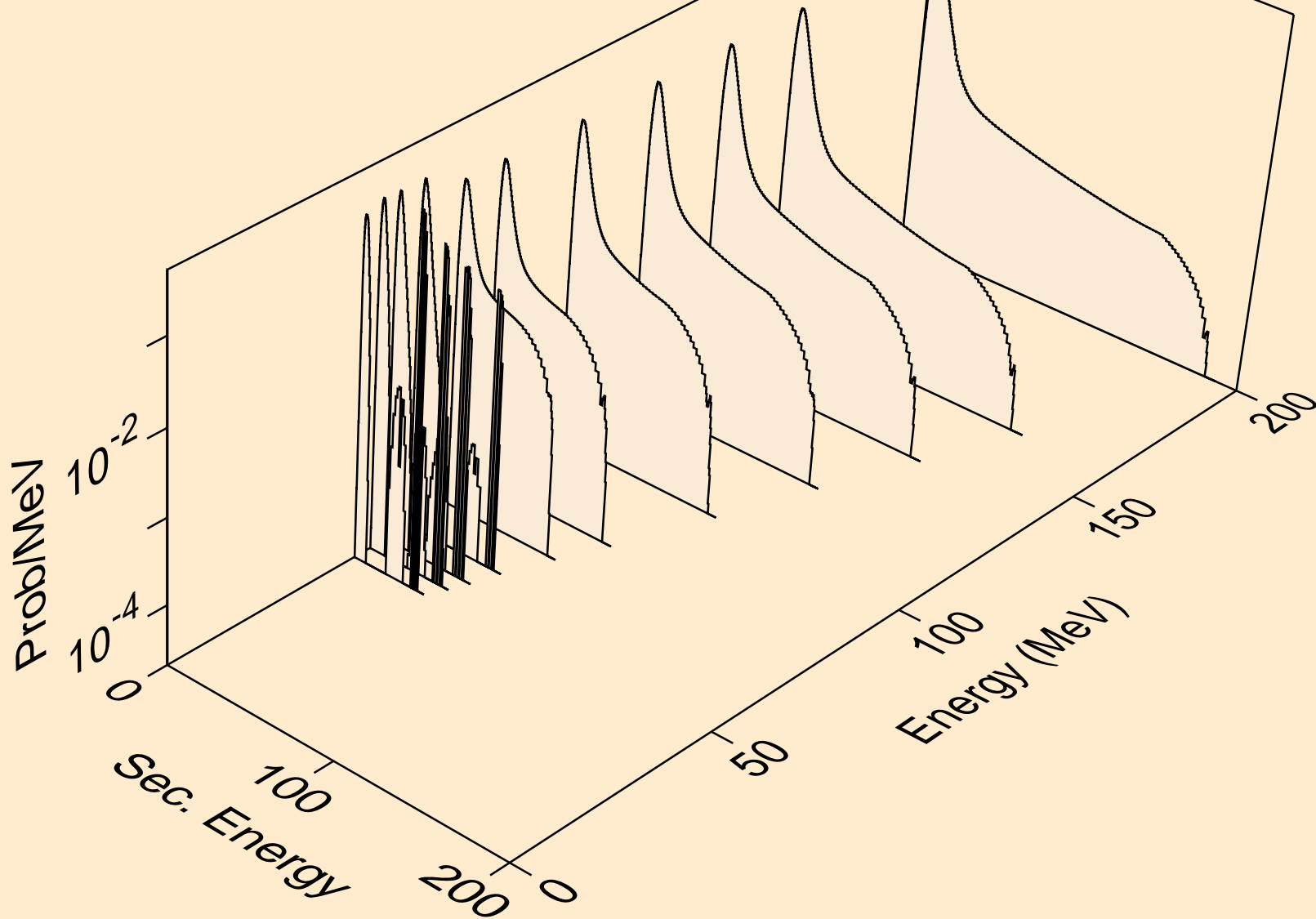

16-S-34 FOR FENDL-3.1 FROM TENDL-2010 WITH NJOY2012.50+
protons from (n,n*)p

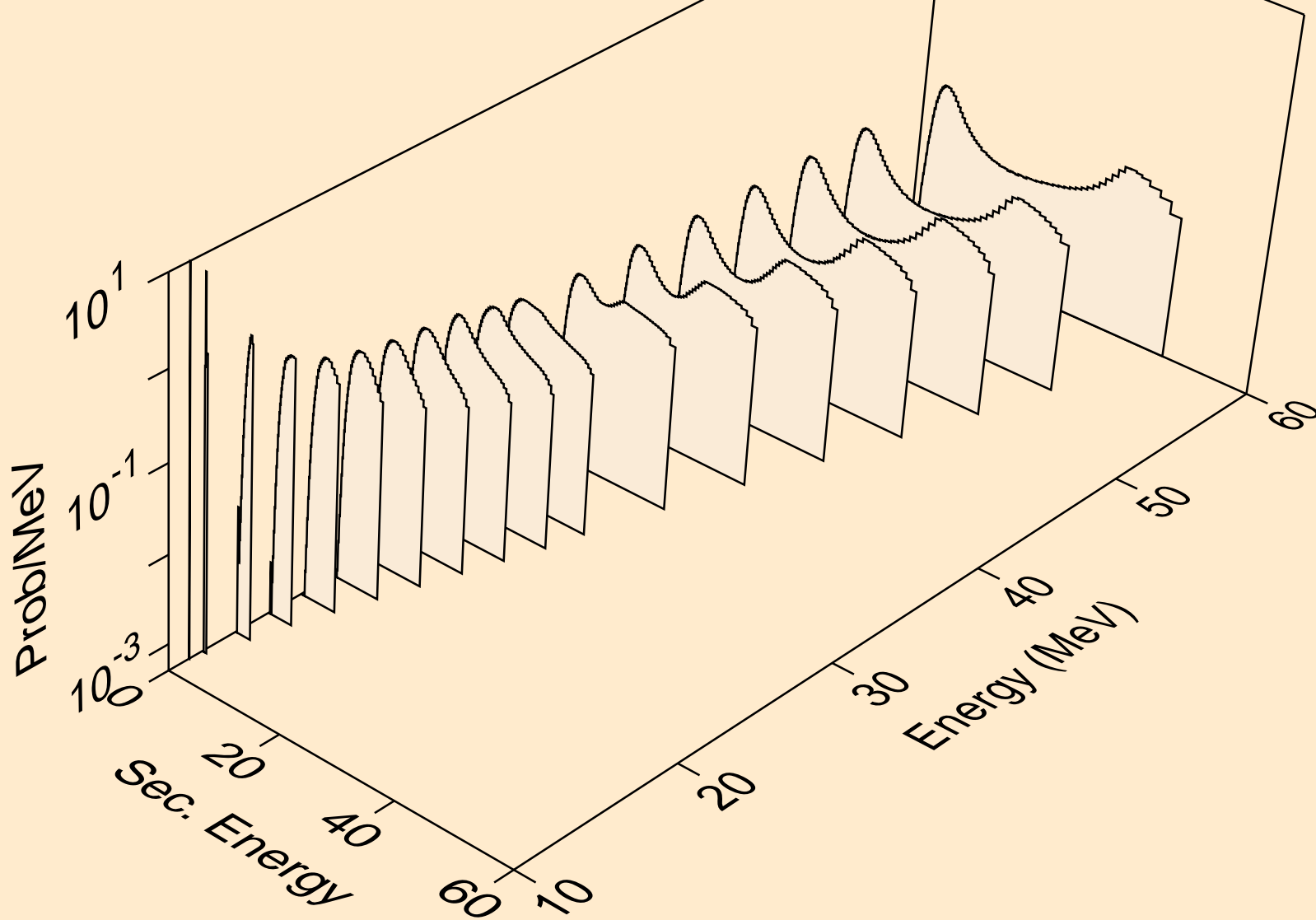

16-S-34 FOR FENDL-3.1 FROM TENDL-2010 WITH NJOY2012.50+
protons from (n,2np)

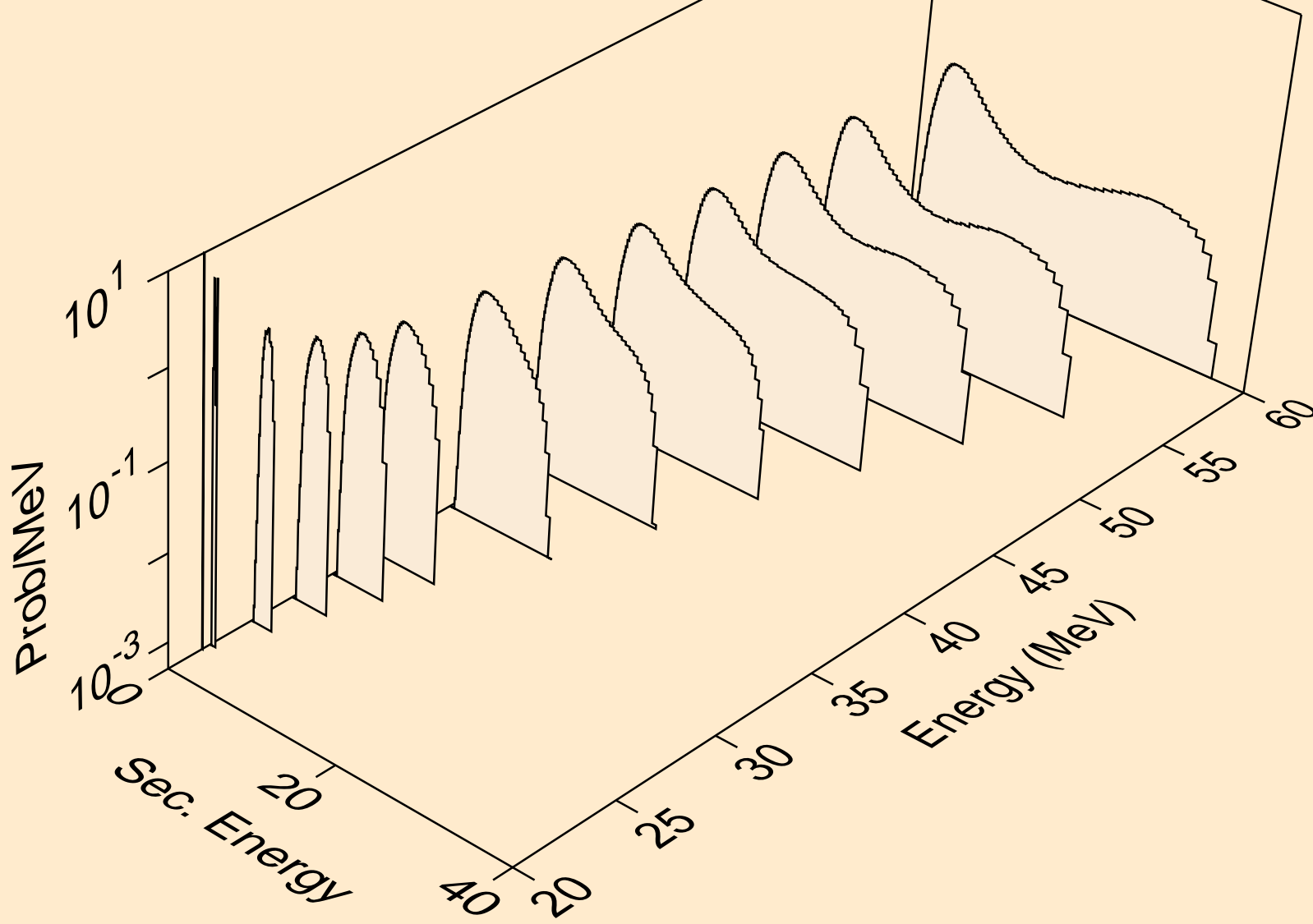

16-S-34 FOR FENDL-3.1 FROM TENDL-2010 WITH NJOY2012.50+
protons from (n,3np)

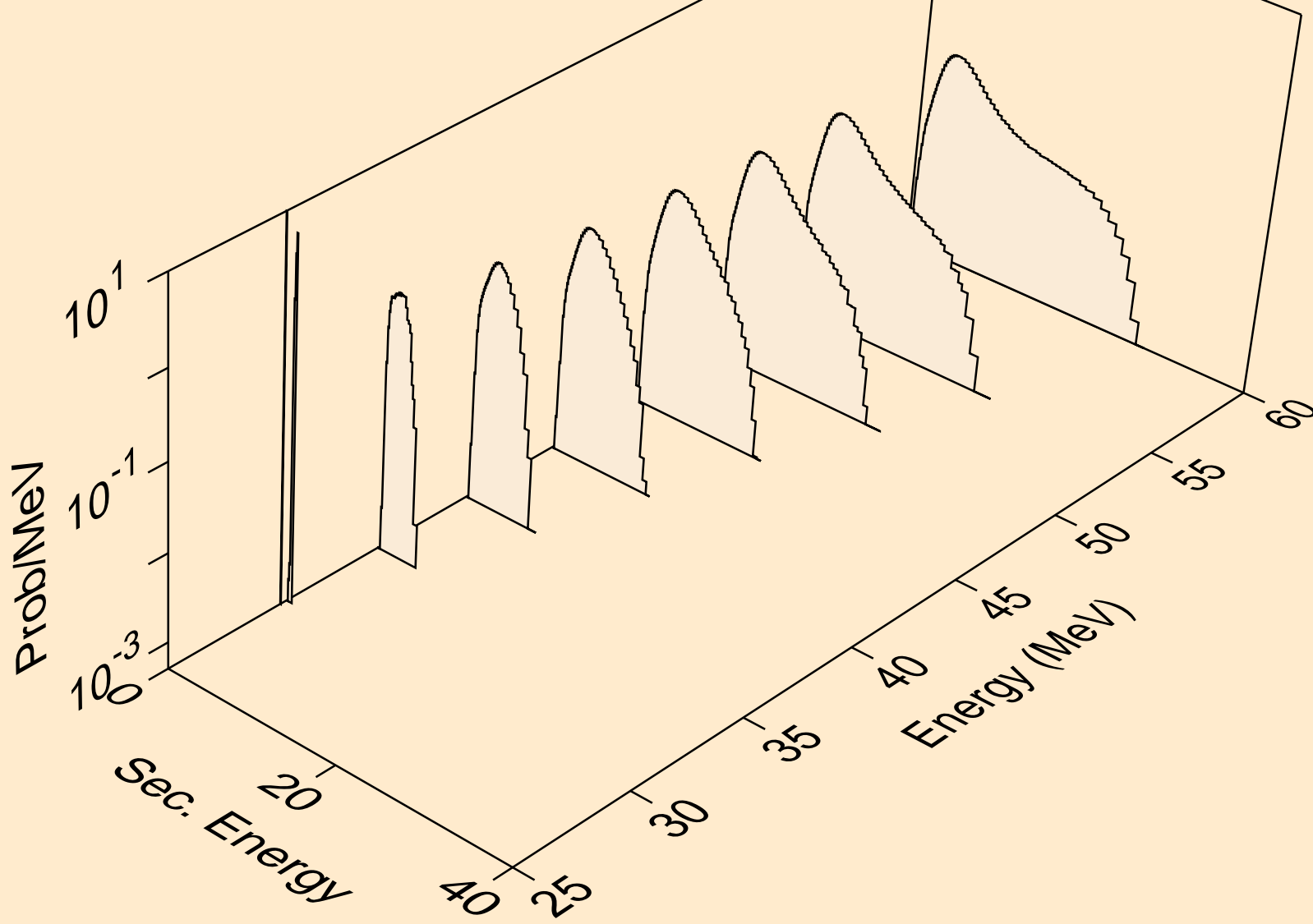

16-S-34 FOR FENDL-3.1 FROM TENDL-2010 WITH NJOY2012.50+
protons from (n,2np)

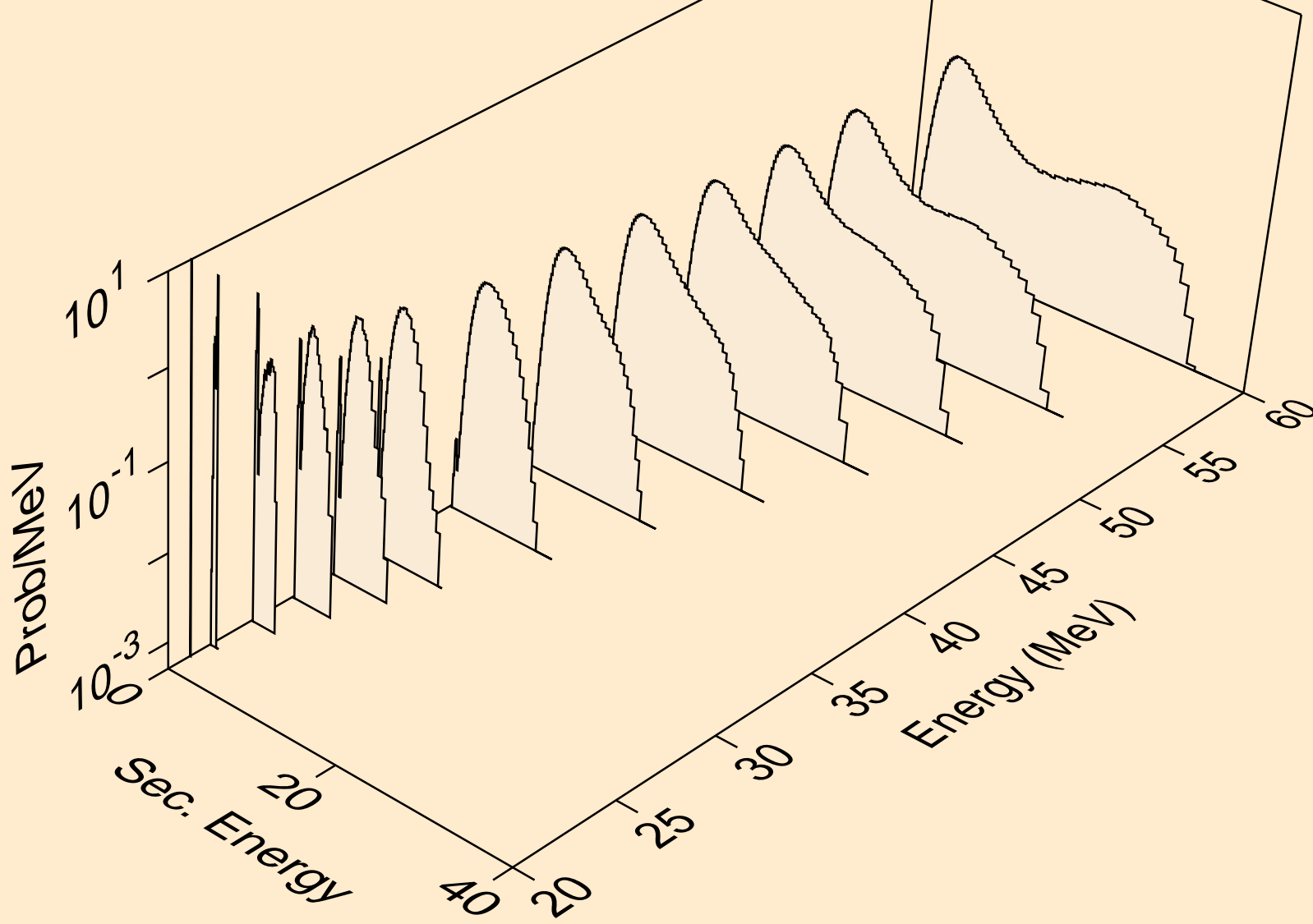

16-S-34 FOR FENDL-3.1 FROM TENDL-2010 WITH NJOY2012.50+
protons from (n,npa)

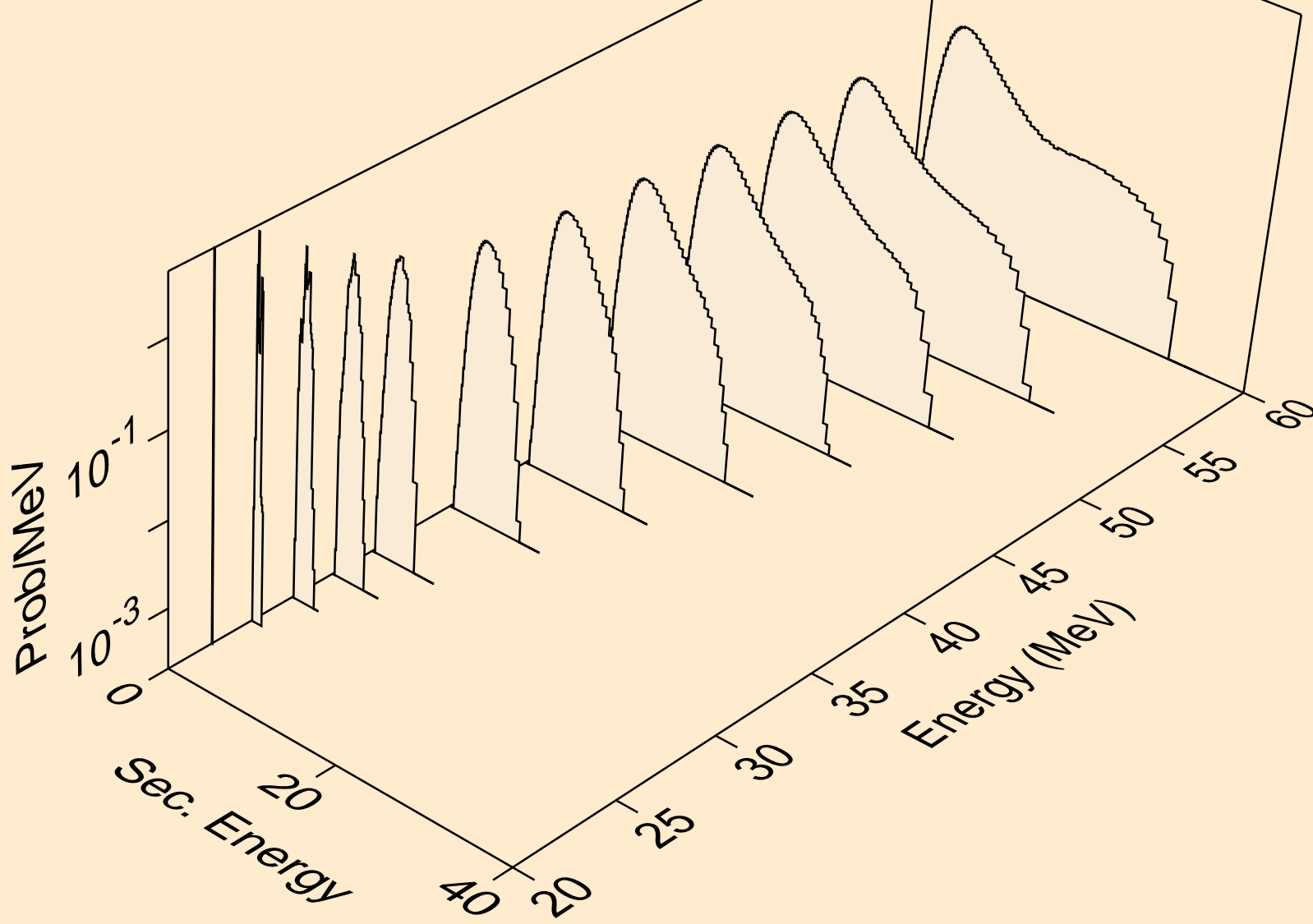

16-S-34 FOR FENDL-3.1 FROM TENDL-2010 WITH NJOY2012.50+
protons from (n,p)

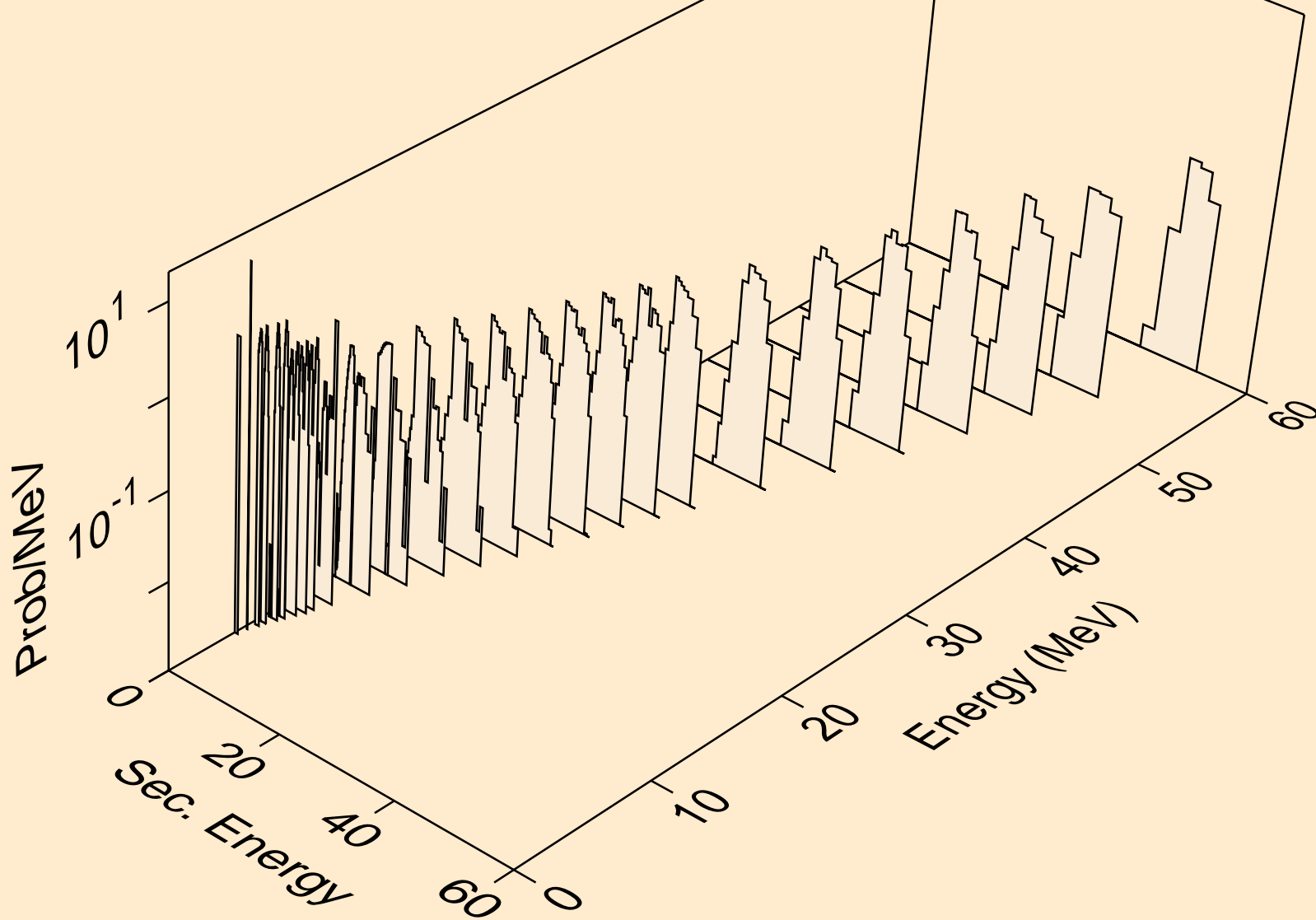

16-S-34 FOR FENDL-3.1 FROM TENDL-2010 WITH NJOY2012.50+
protons from (n,2p)

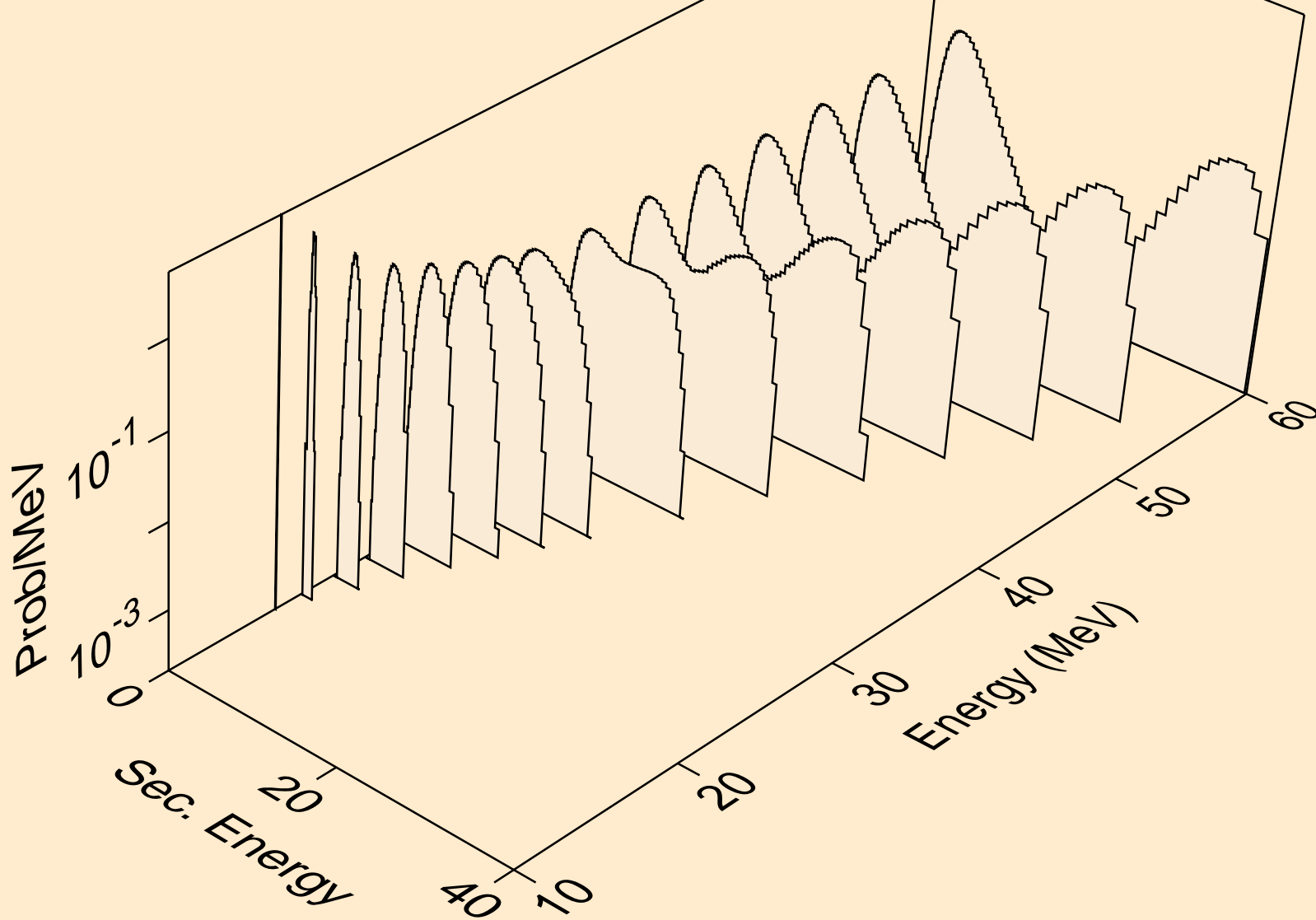

16-S-34 FOR FENDL-3.1 FROM TENDL-2010 WITH NJOY2012.50+
protons from (n,pa)

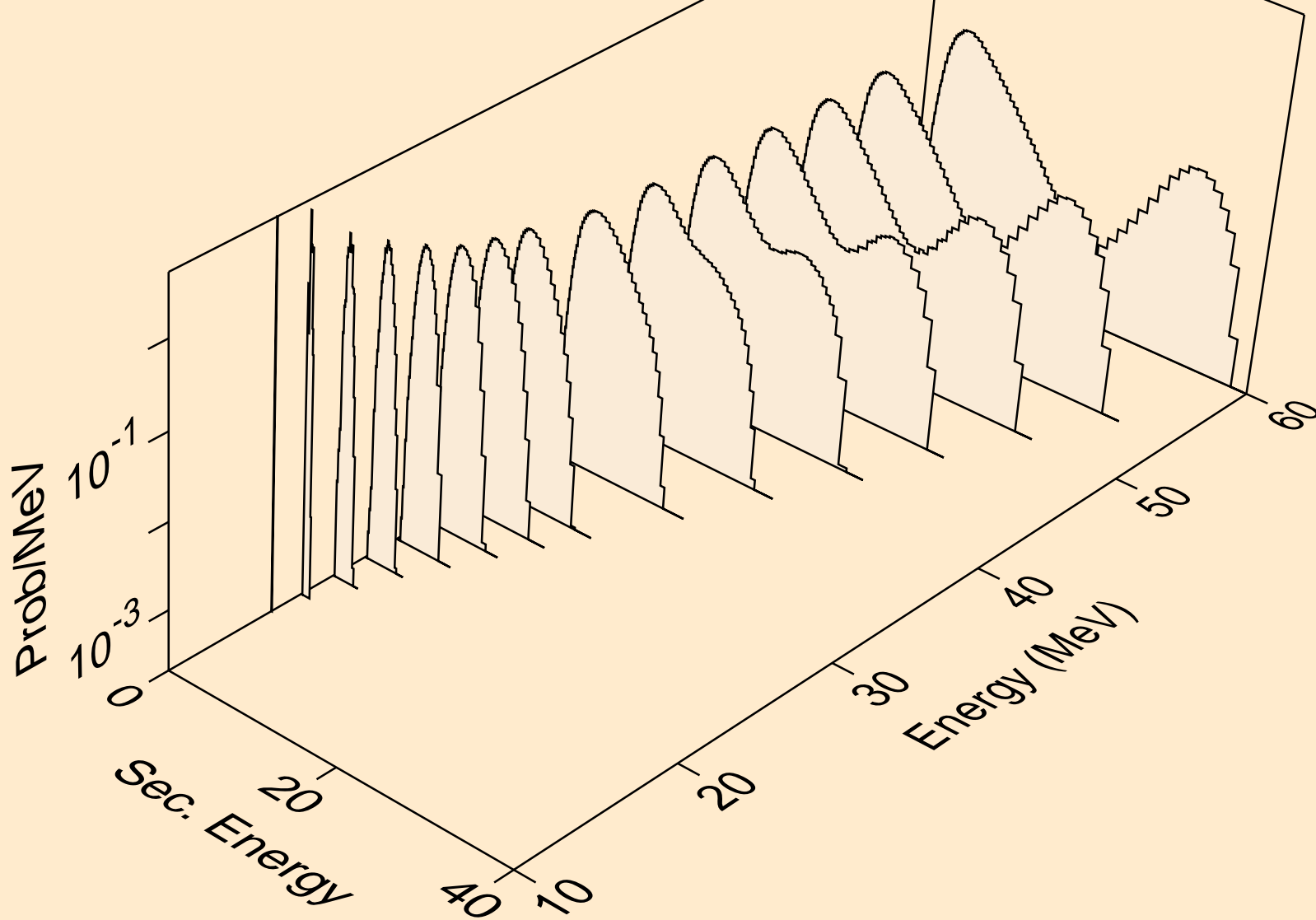

16-S-34 FOR FENDL-3.1 FROM TENDL-2010 WITH NJOY2012.50+
protons from (n,pd)

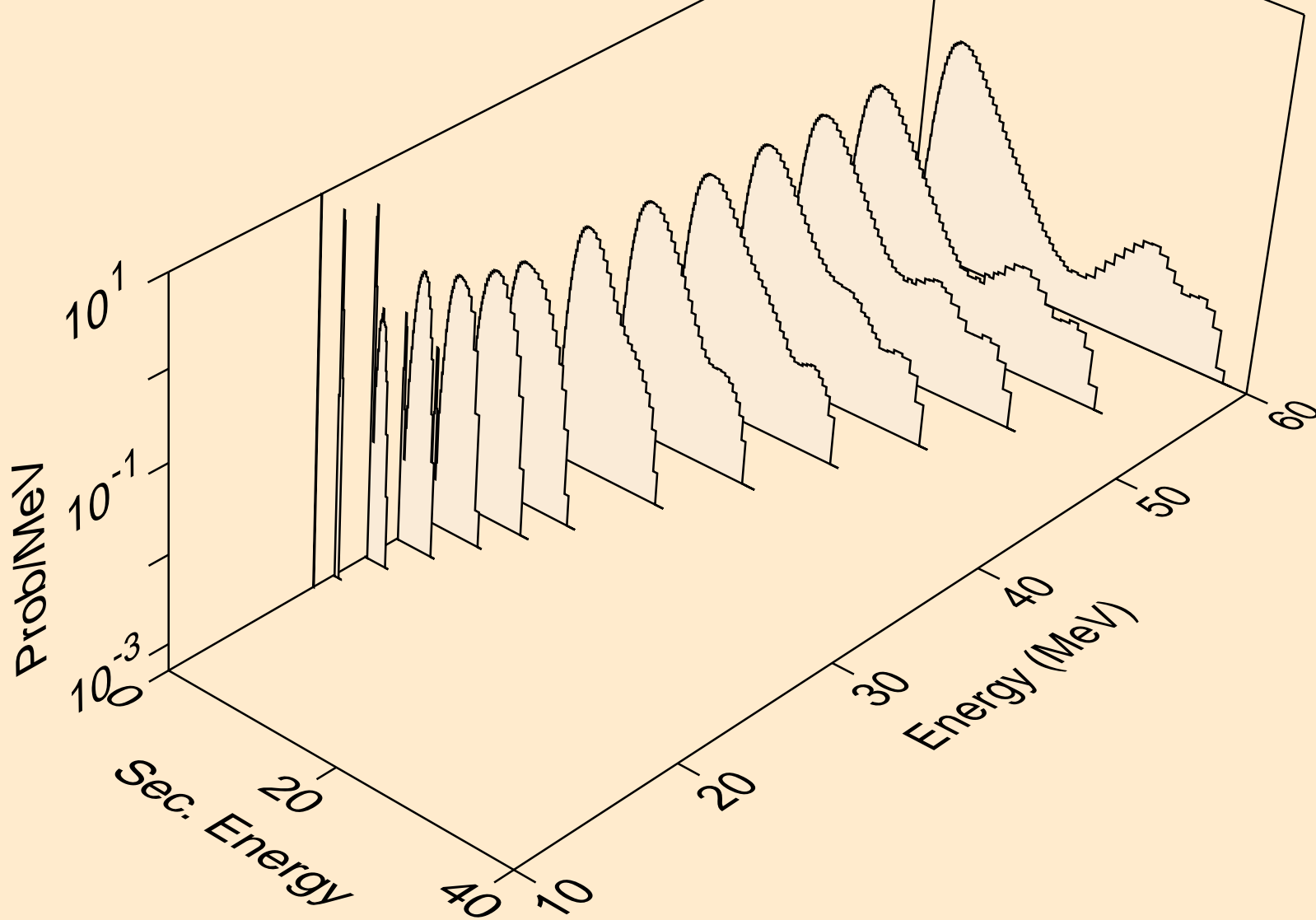

16-S-34 FOR FENDL-3.1 FROM TENDL-2010 WITH NJOY2012.50+
protons from (n,pt)

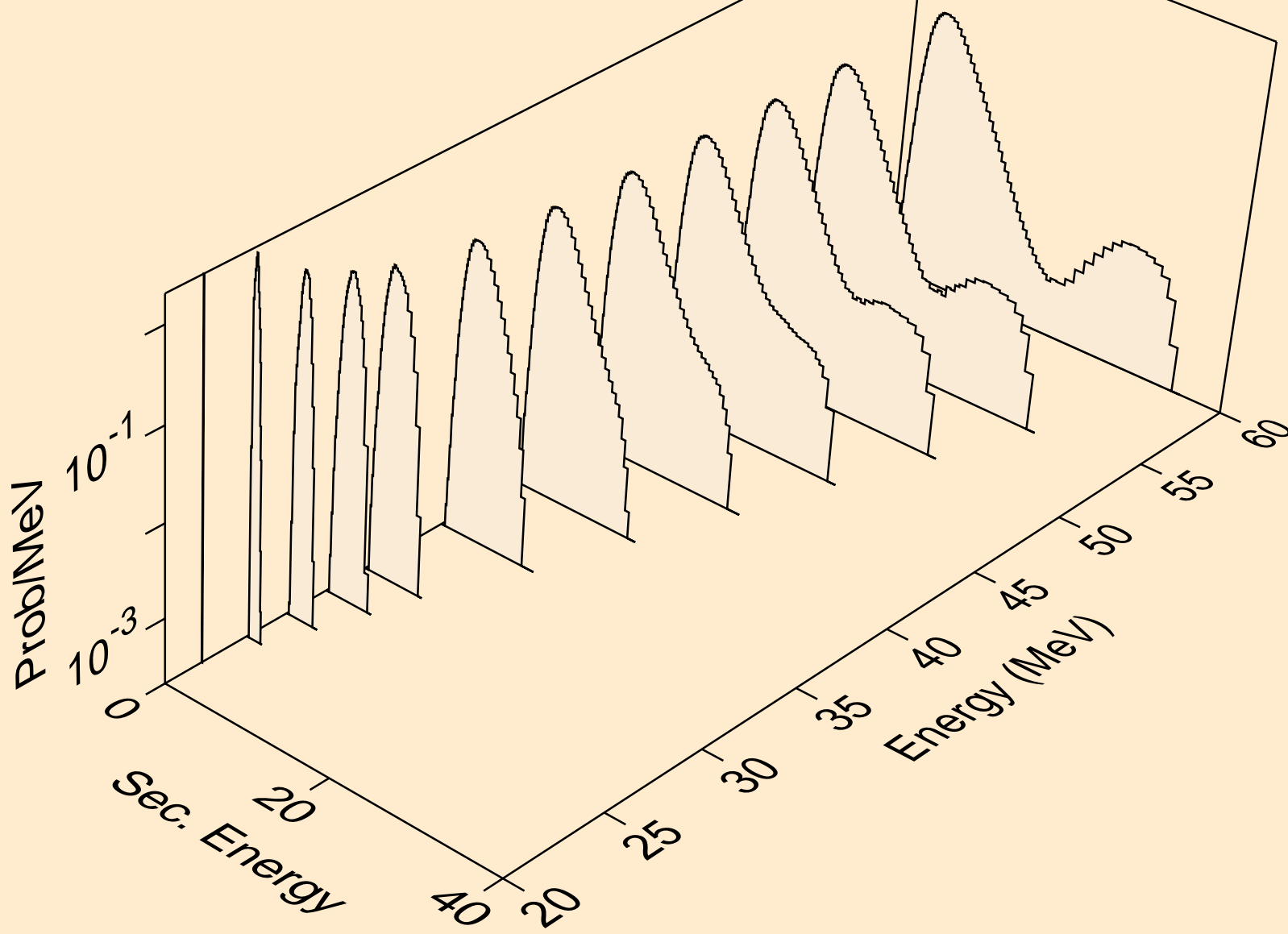

16-S-34 FOR FENDL-3.1 FROM TENDL-2010 WITH NJOY2012.50+
protons from (n,4np)

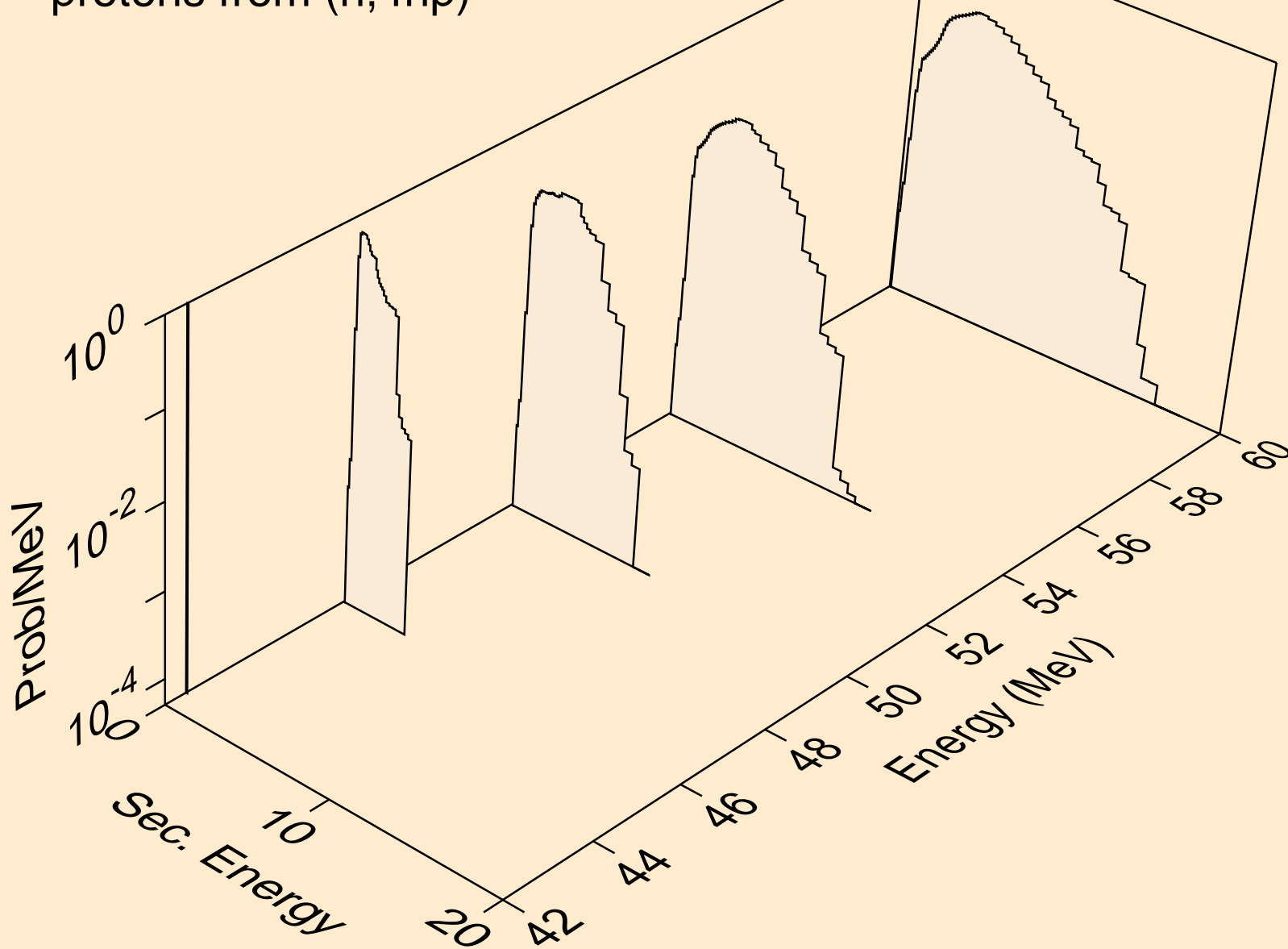

16-S-34 FOR FENDL-3.1 FROM TENDL-2010 WITH NJOY2012.50+
protons from (n,2npa)

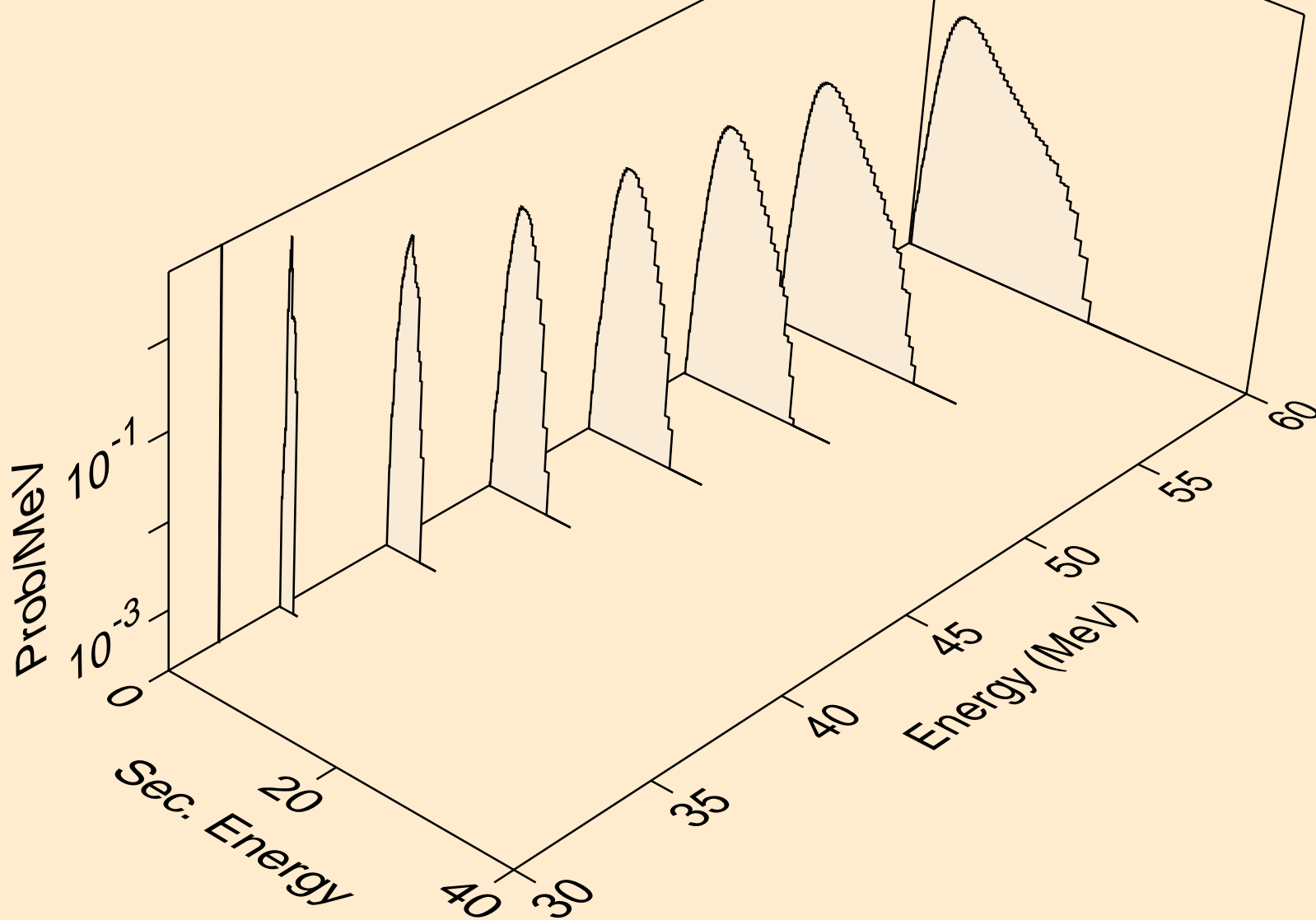

16-S-34 FOR FENDL-3.1 FROM TENDL-2010 WITH NJOY2012.50+
protons from (n,5np)

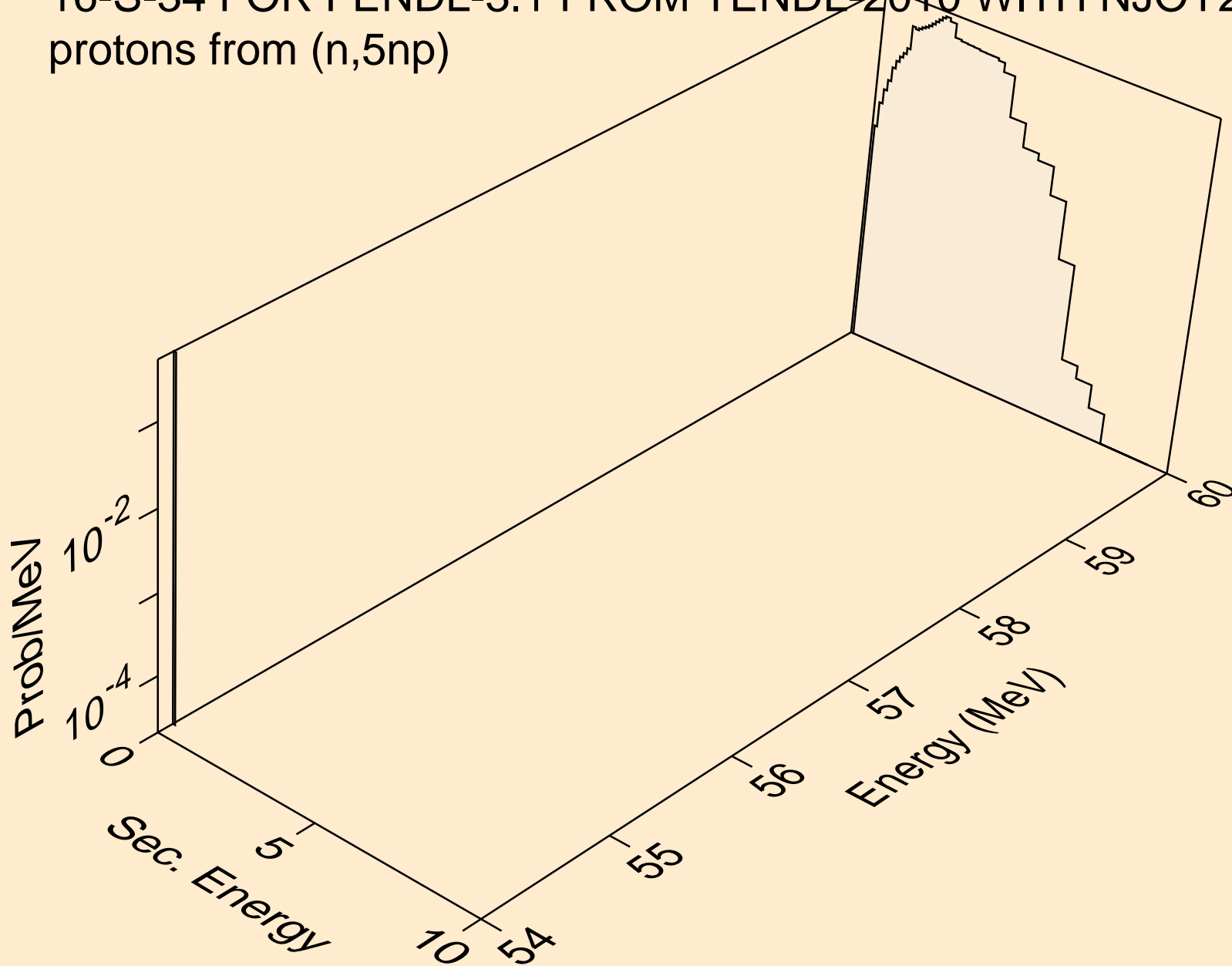

16-S-34 FOR FENDL-3.1 FROM TENDL-2010 WITH NJOY2012.50+
protons from (n,3n2p)

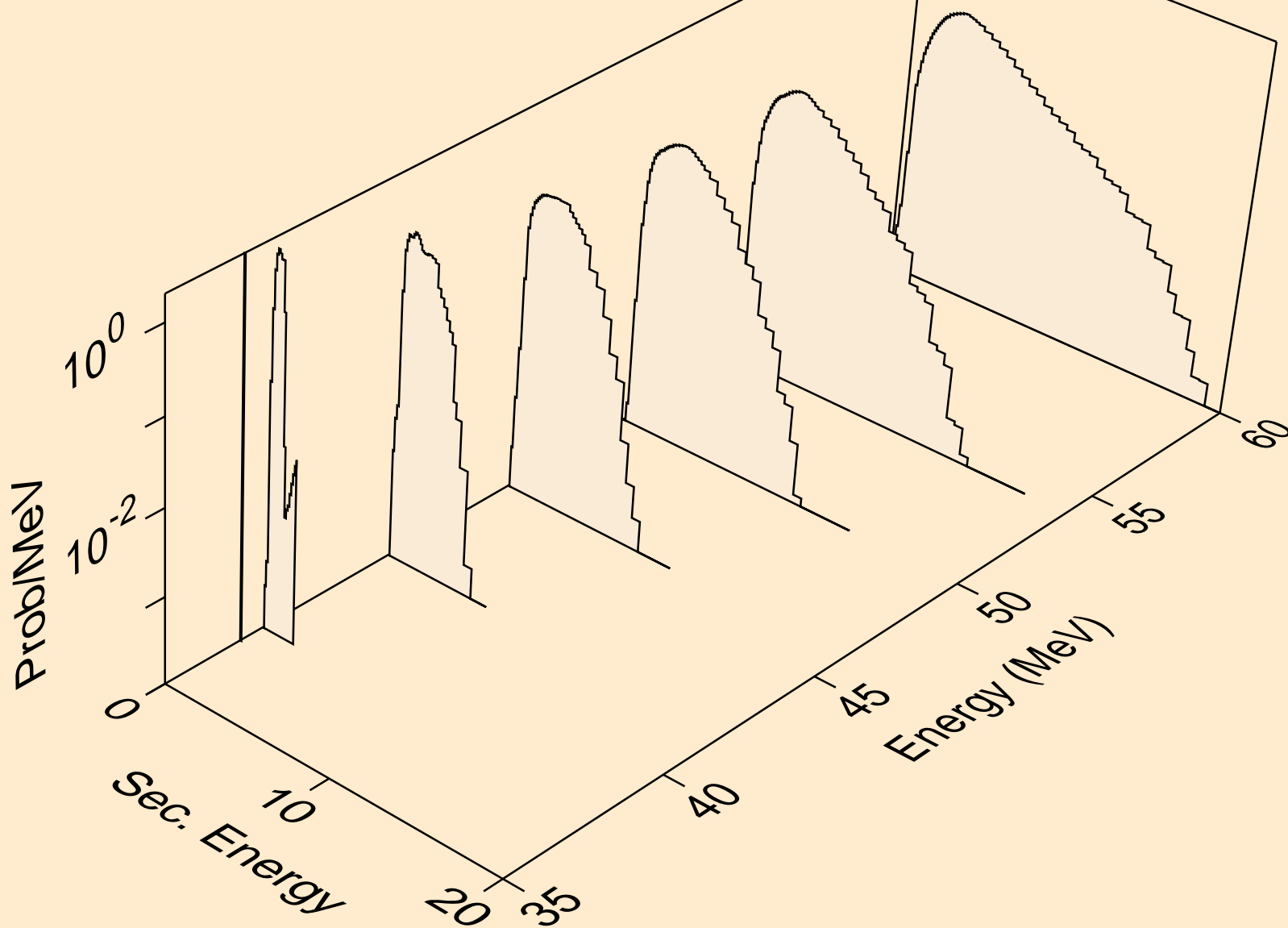

16-S-34 FOR FENDL-3.1 FROM TENDL-2010 WITH NJOY2012.50+
protons from (n,3npa)

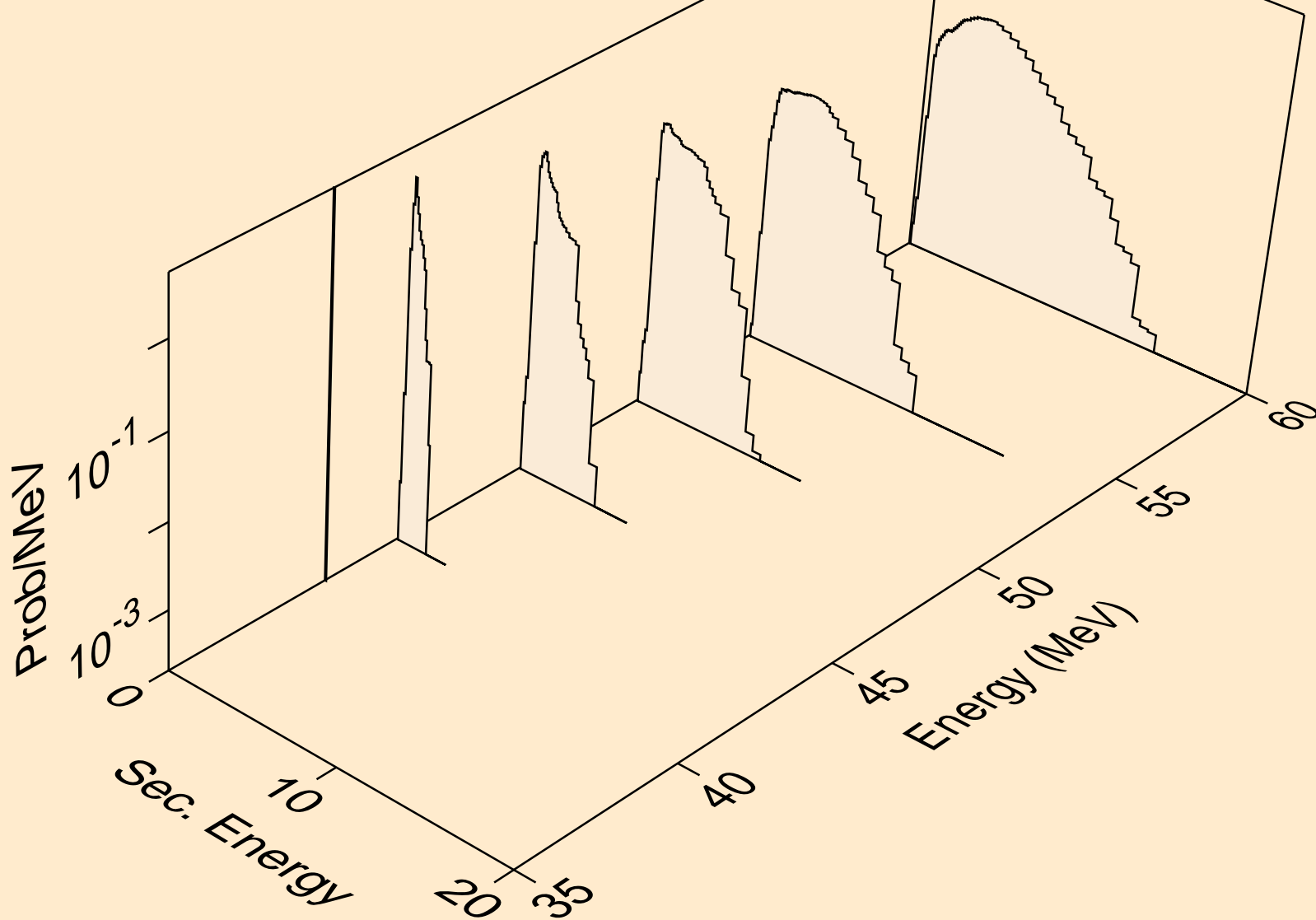

16-S-34 FOR FENDL-3.1 FROM TENDL-2010 WITH NJOY2012.50+
protons from (n,npd)

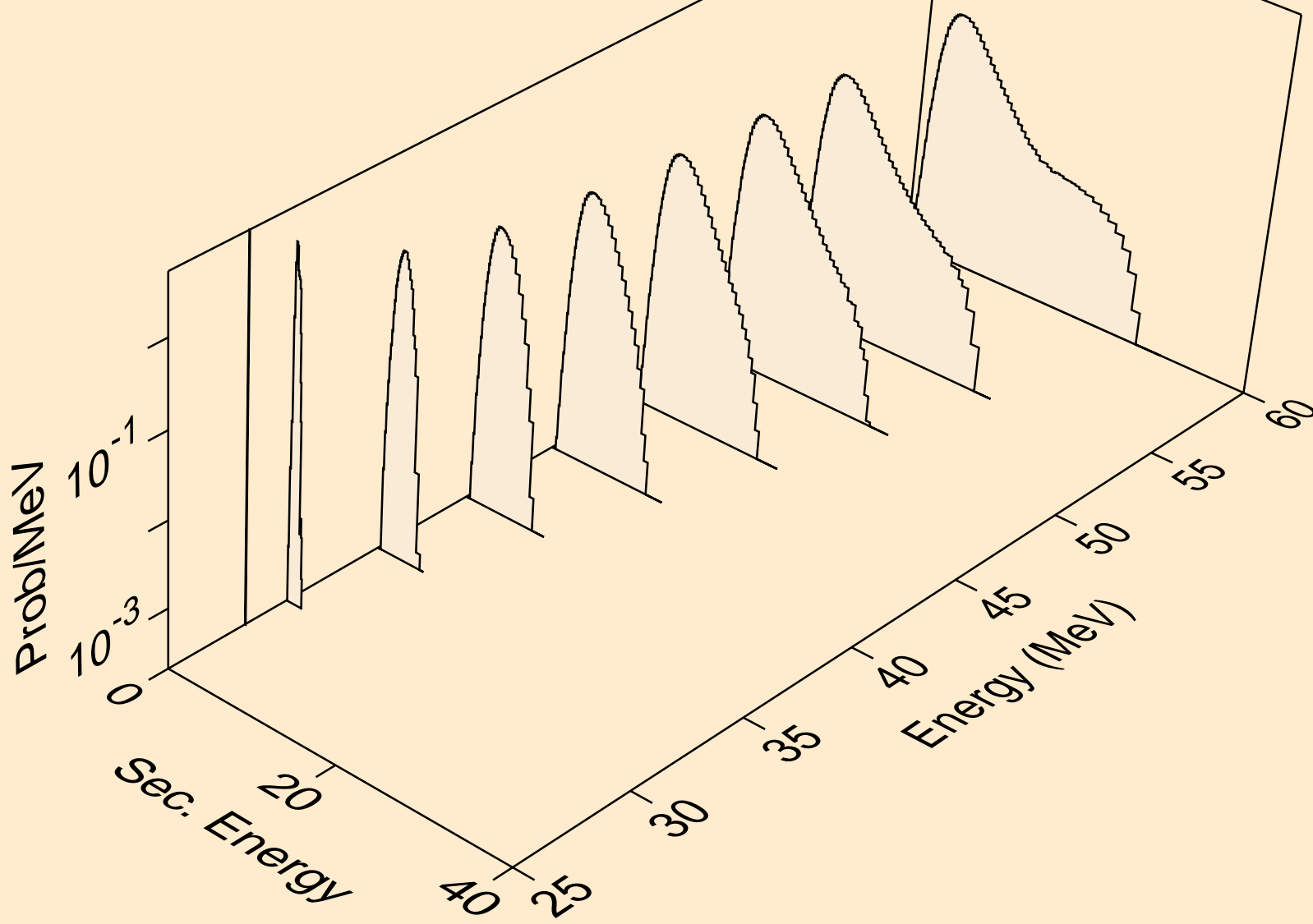

16-S-34 FOR FENDL-3.1 FROM TENDL-2010 WITH NJOY2012.50+
protons from (n,npt)

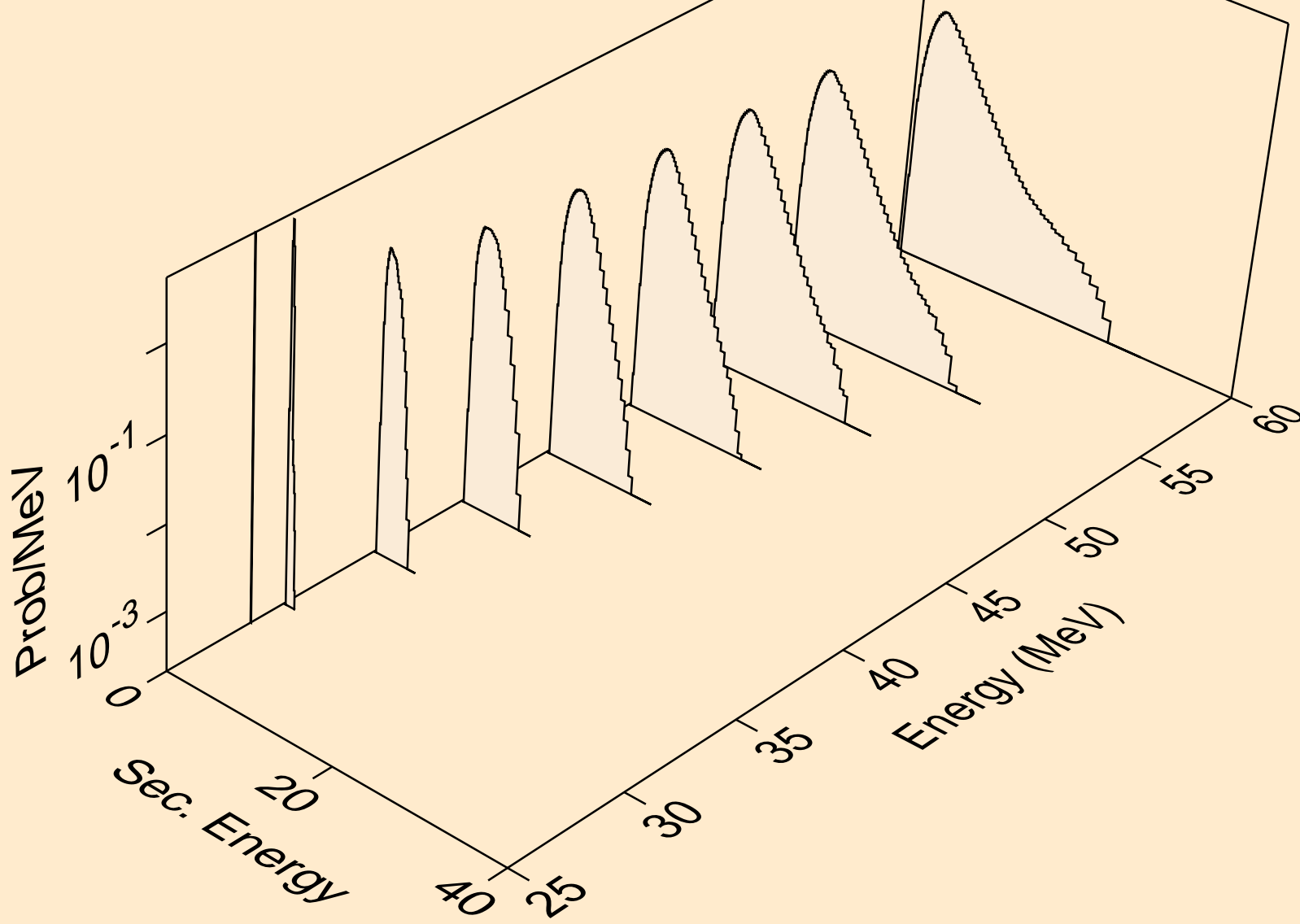

16-S-34 FOR FENDL-3.1 FROM TENDL-2010 WITH NJOY2012.50+
protons from (n,nphe3)

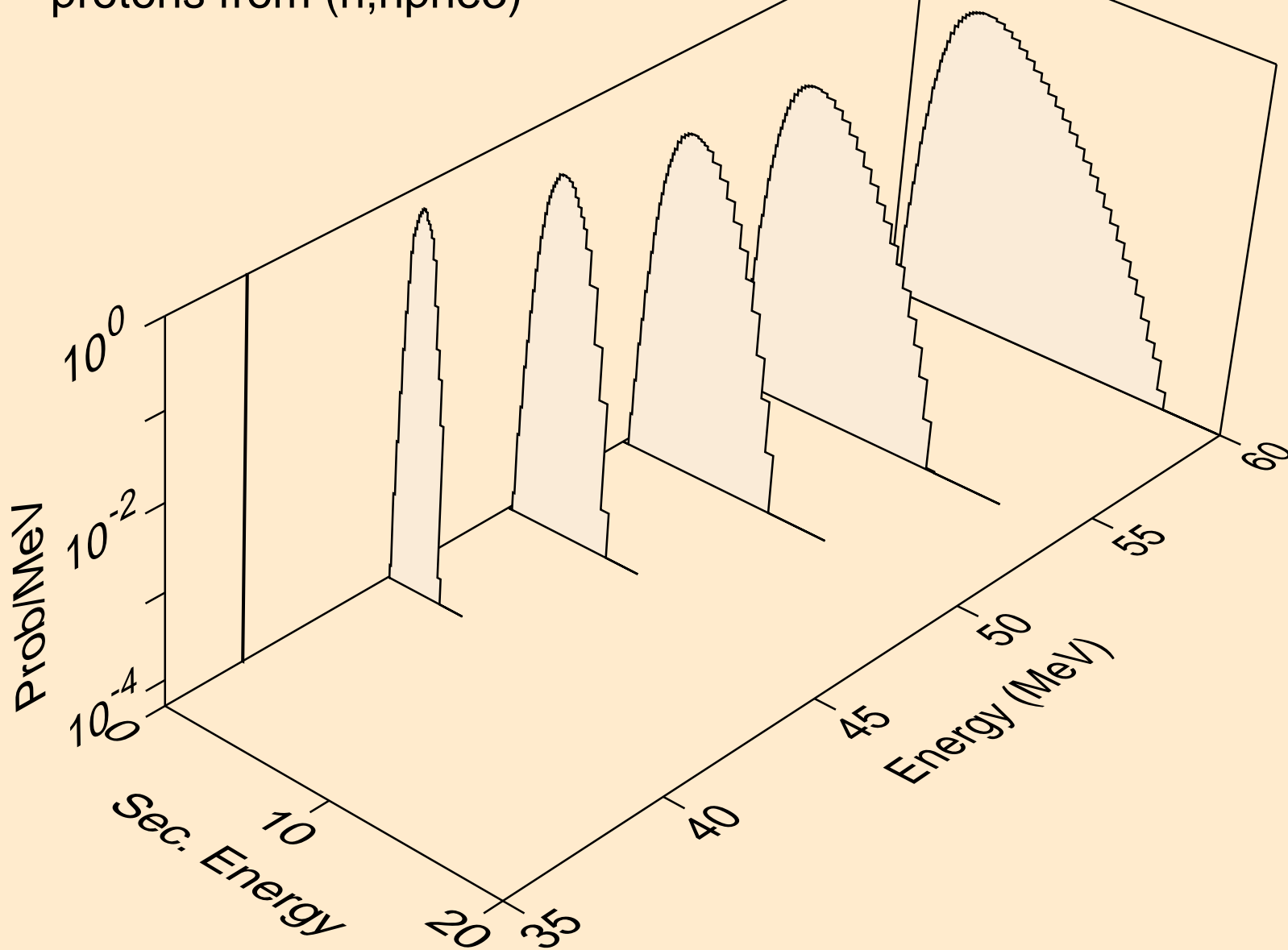

16-S-34 FOR FENDL-3.1 FROM TENDL-2010 WITH NJOY2012.50+
protons from (n,2n2p)

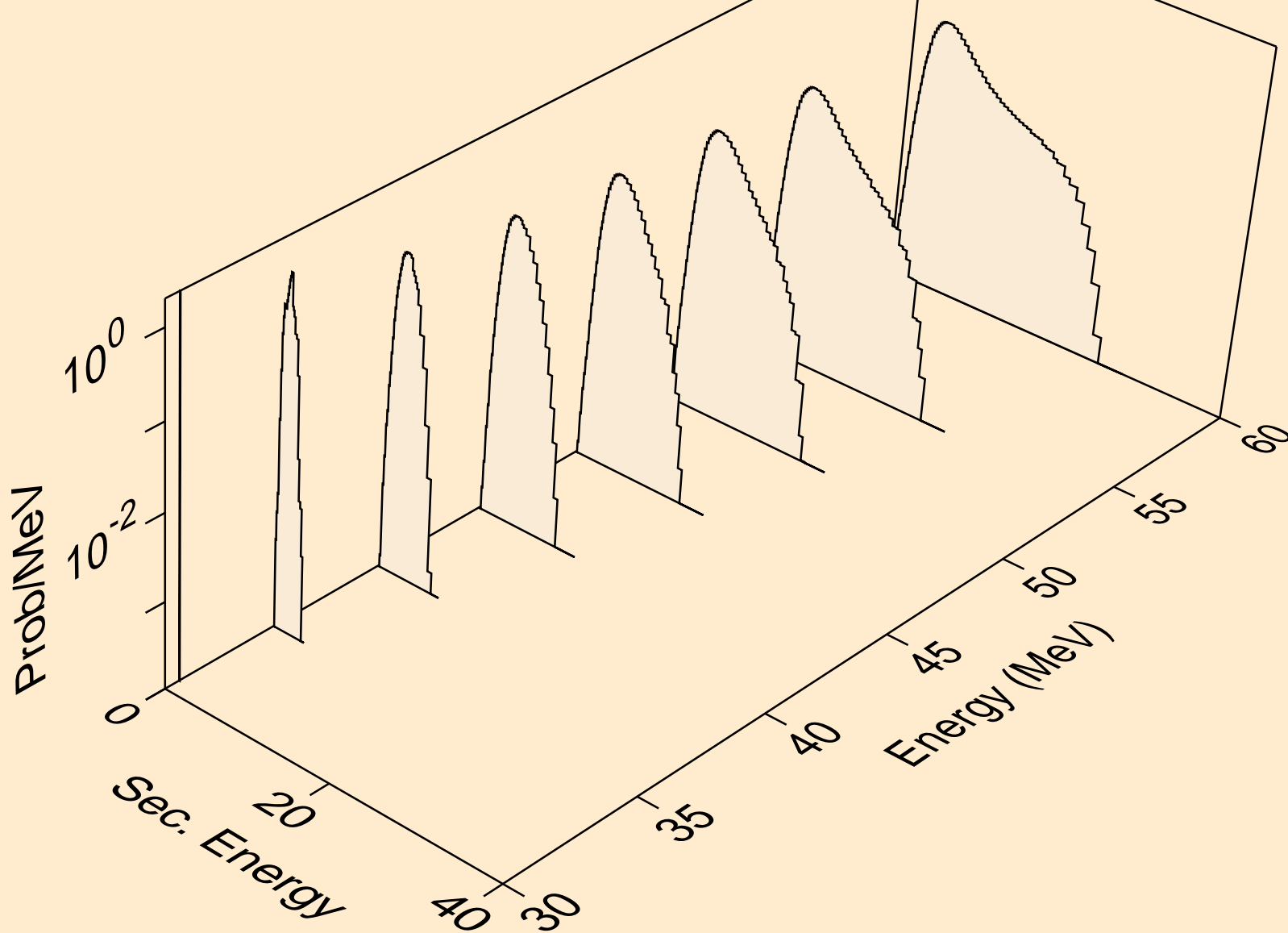

16-S-34 FOR FENDL-3.1 FROM TENDL-2010 WITH NJOY2012.50+
protons from (n,phe3)

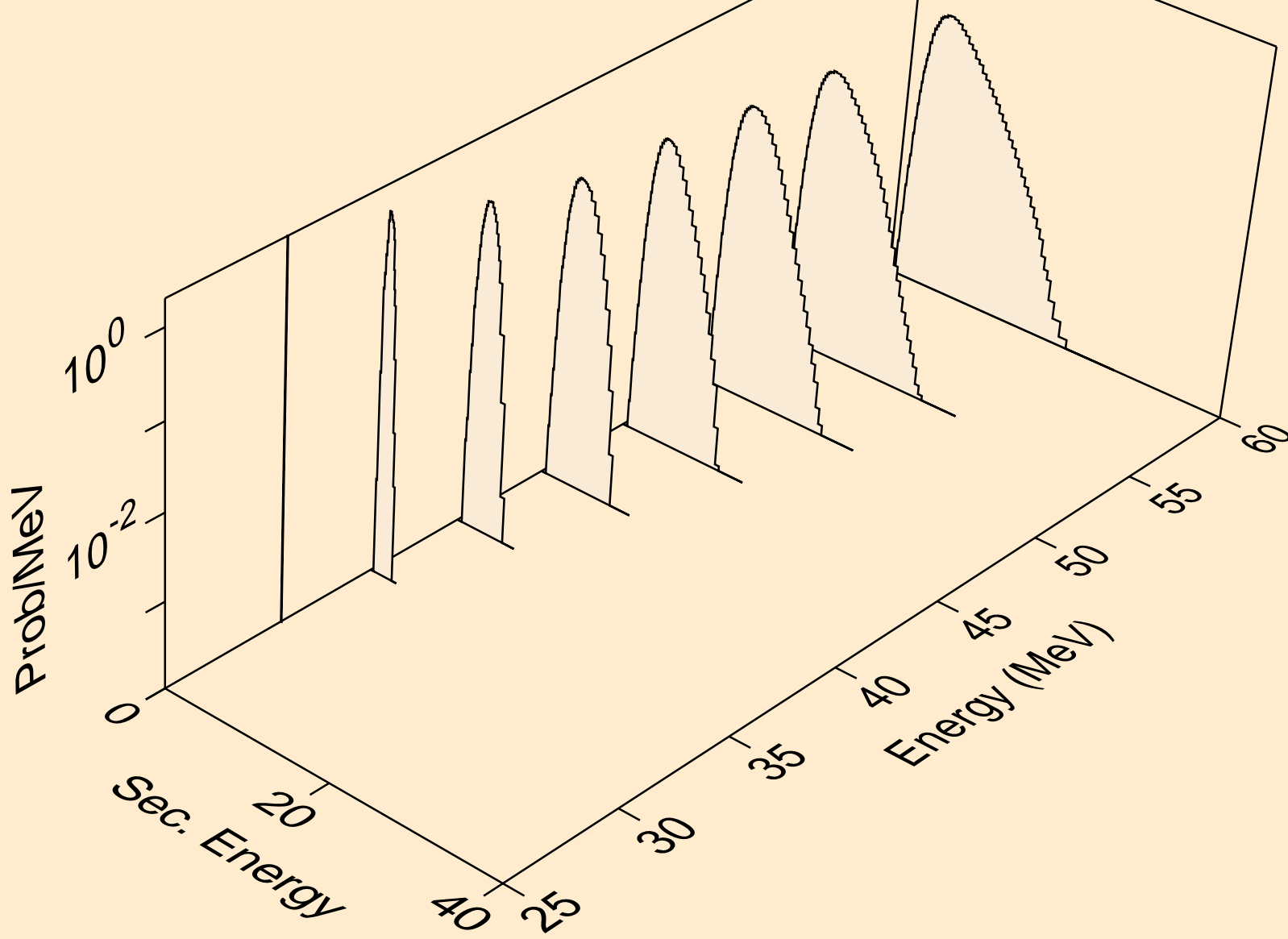

16-S-34 FOR FENDL-3.1 FROM TENDL-2010 WITH NJOY2012.50+
protons from (n,4n2p)

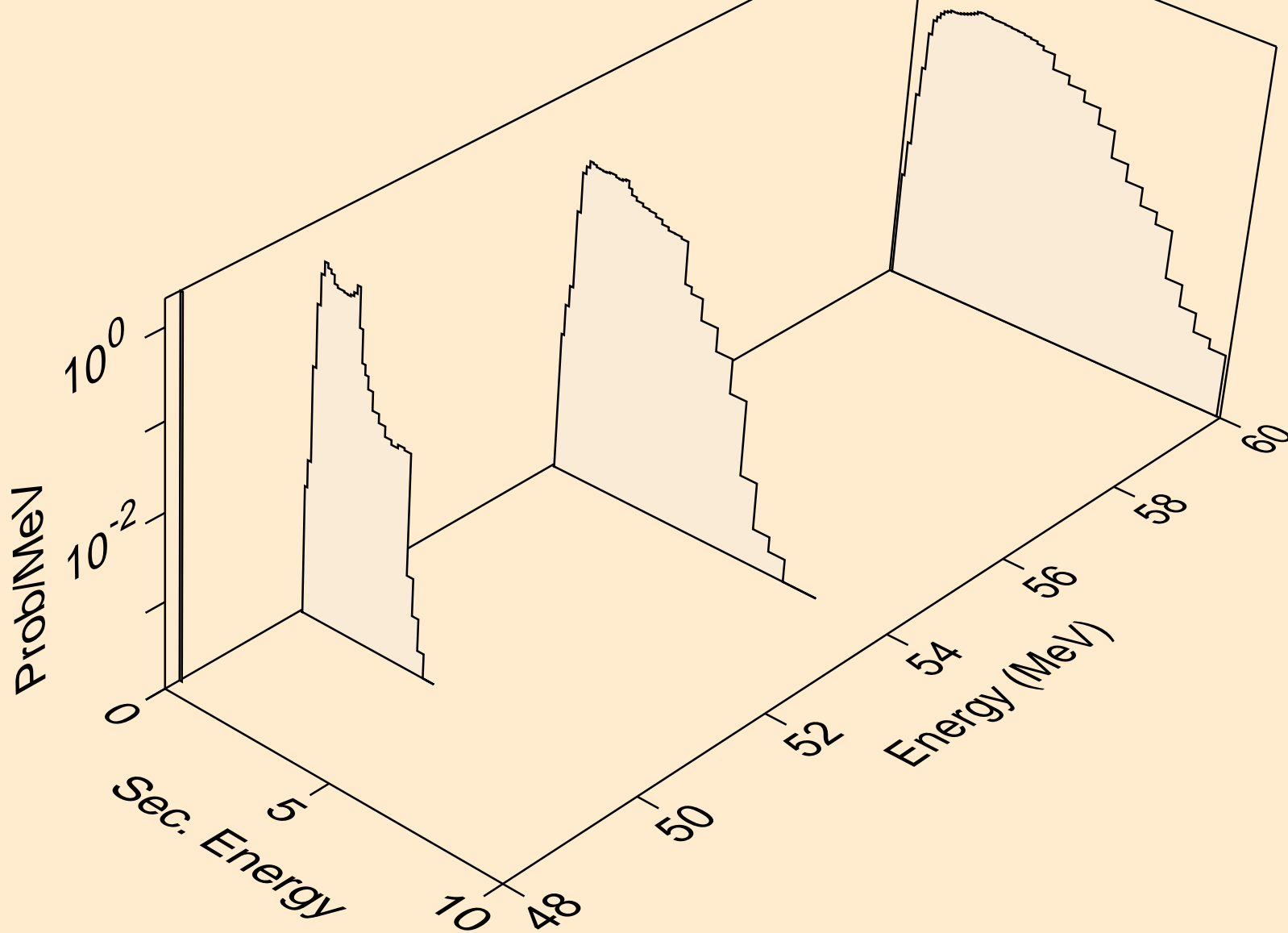

16-S-34 FOR FENDL-3.1 FROM TENDL-2010 WITH NJOY2012.50+
protons from (n,4npa)

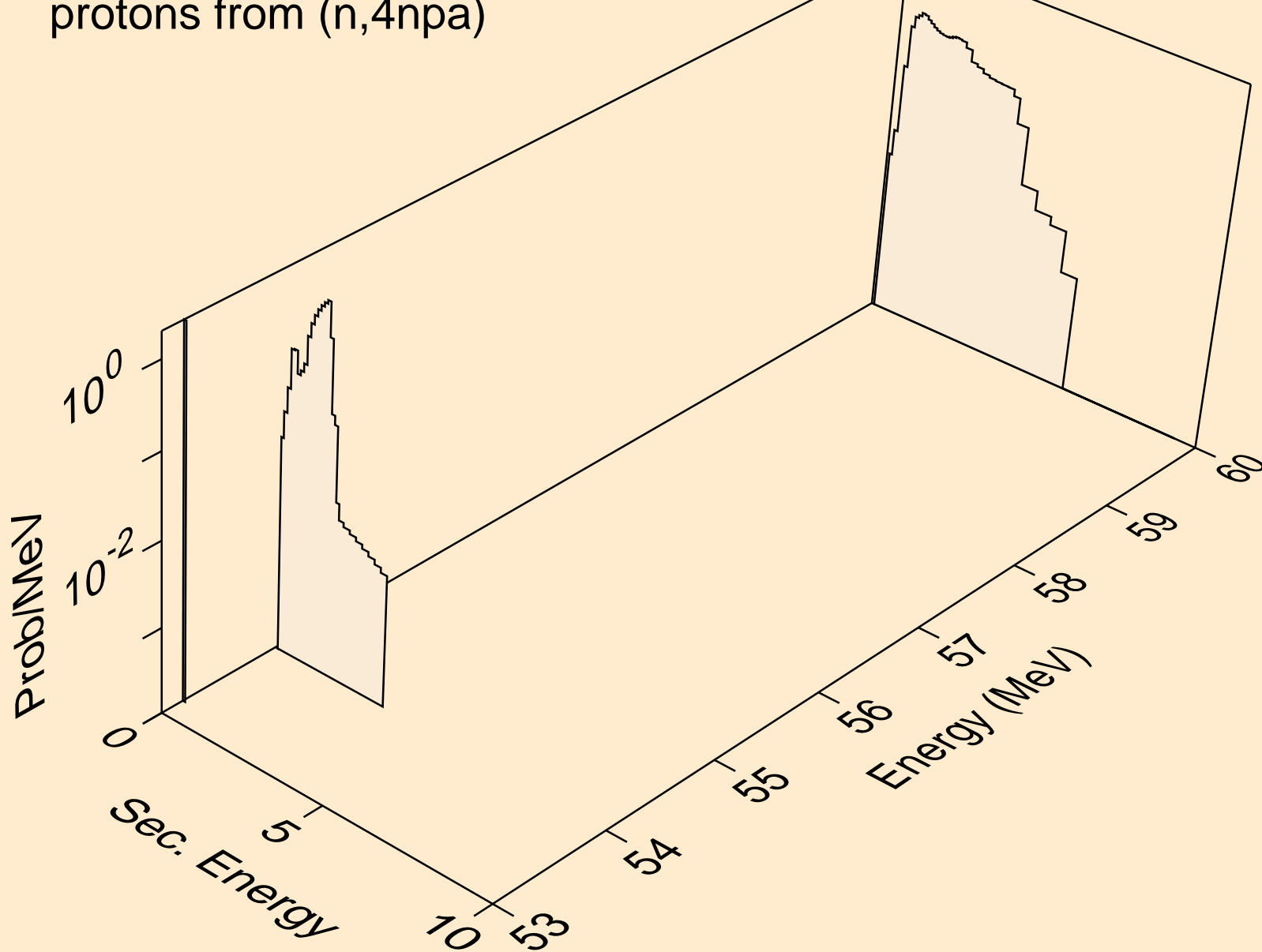

16-S-34 FOR FENDL-3.1 FROM TENDL-2010 WITH NJOY2012.50+
protons from (n,3p)

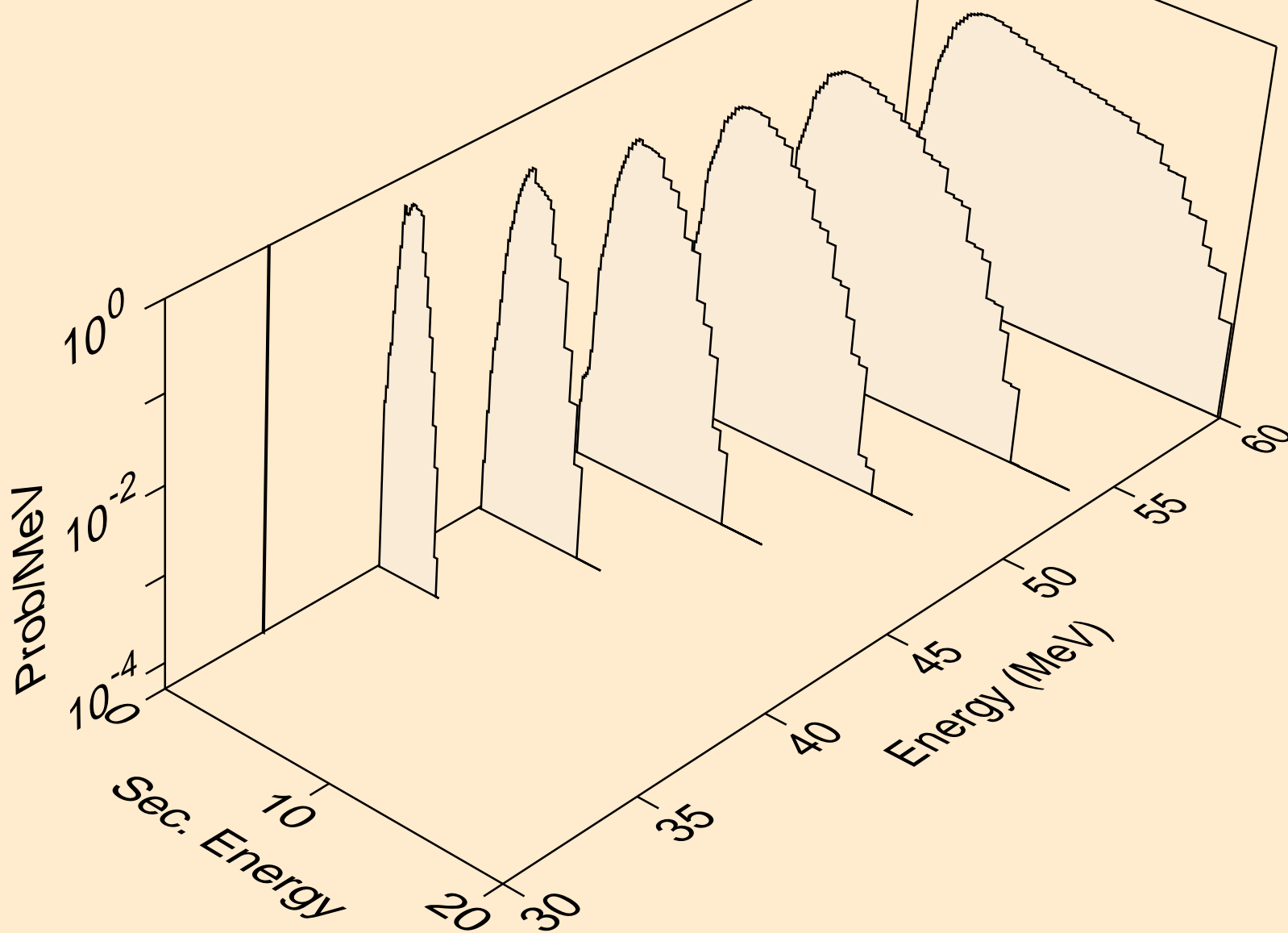

16-S-34 FOR FENDL-3.1 FROM TENDL-2010 WITH NJOY2012.50+
protons from (n,n3p)

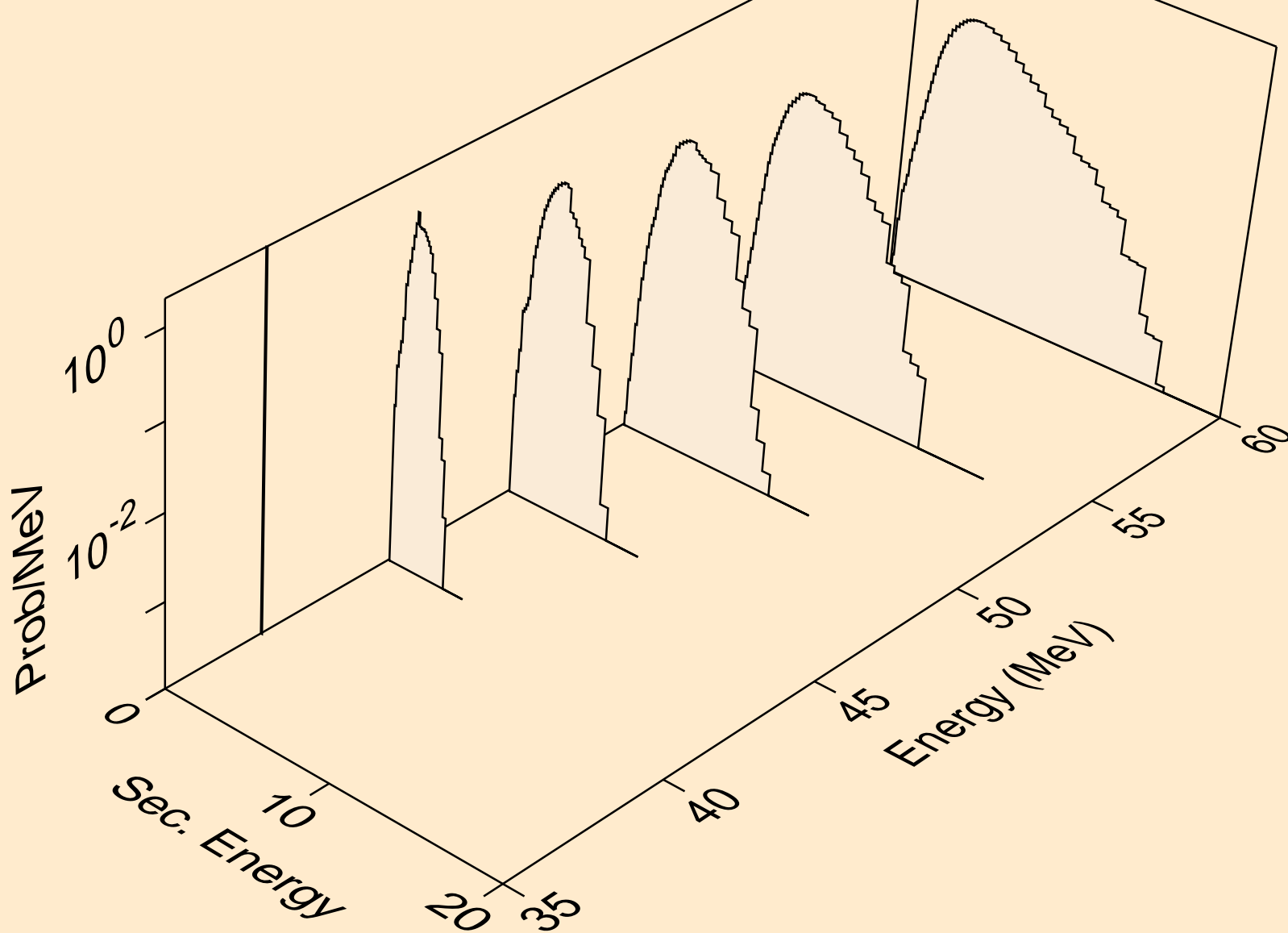

16-S-34 FOR FENDL-3.1 FROM TENDL-2010 WITH NJOY2012.50+
protons from (n,3n2pa)

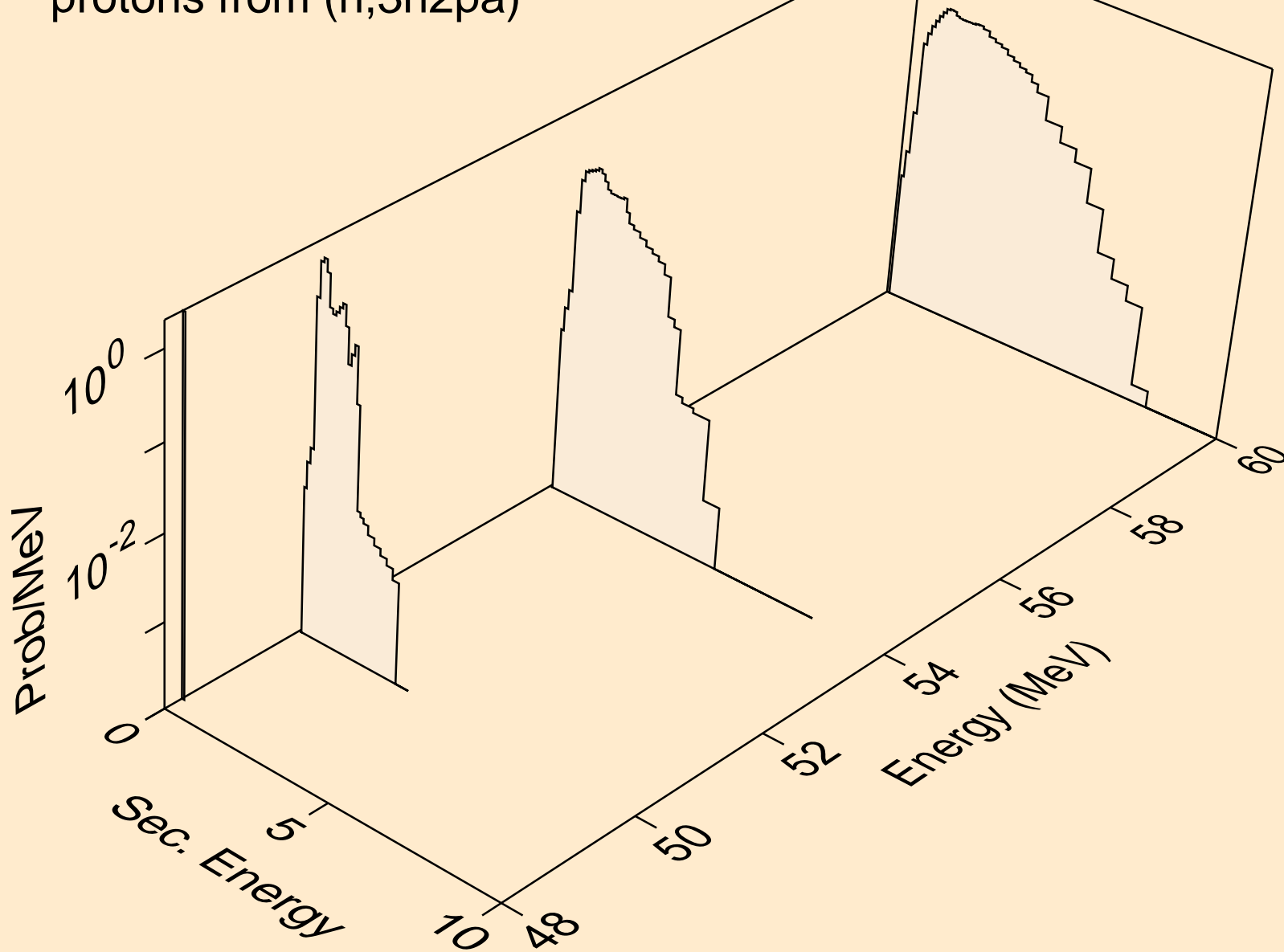

16-S-34 FOR FENDL-3.1 FROM TENDL-2010 WITH NJOY2012.50+
deuterons from (n,x)

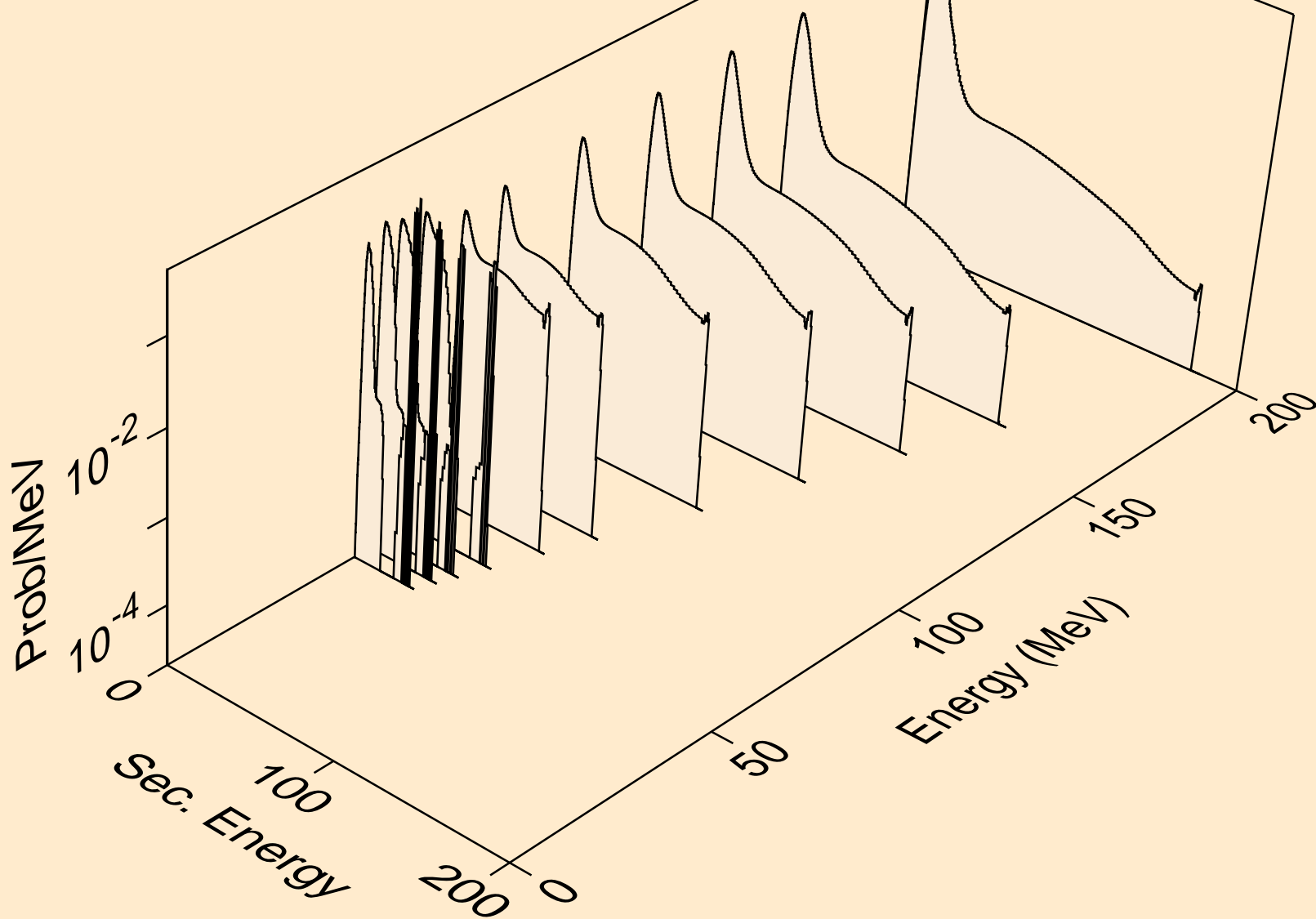

16-S-34 FOR FENDL-3.1 FROM TENDL-2010 WITH NJOY2012.50+
deuterons from (n,2nd)

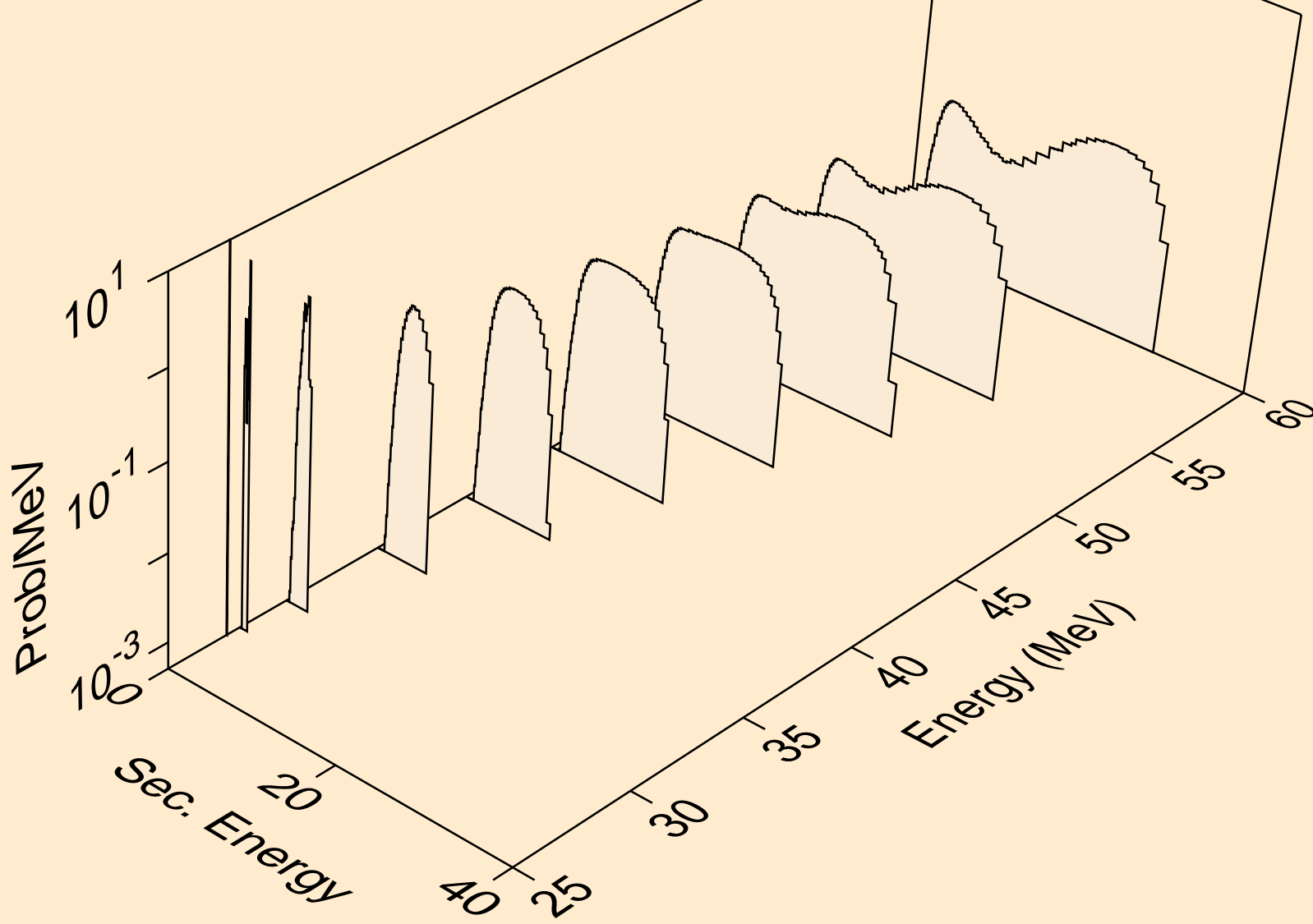

16-S-34 FOR FENDL-3.1 FROM TENDL-2010 WITH NJOY2012.50+
deuterons from (n,n*)d

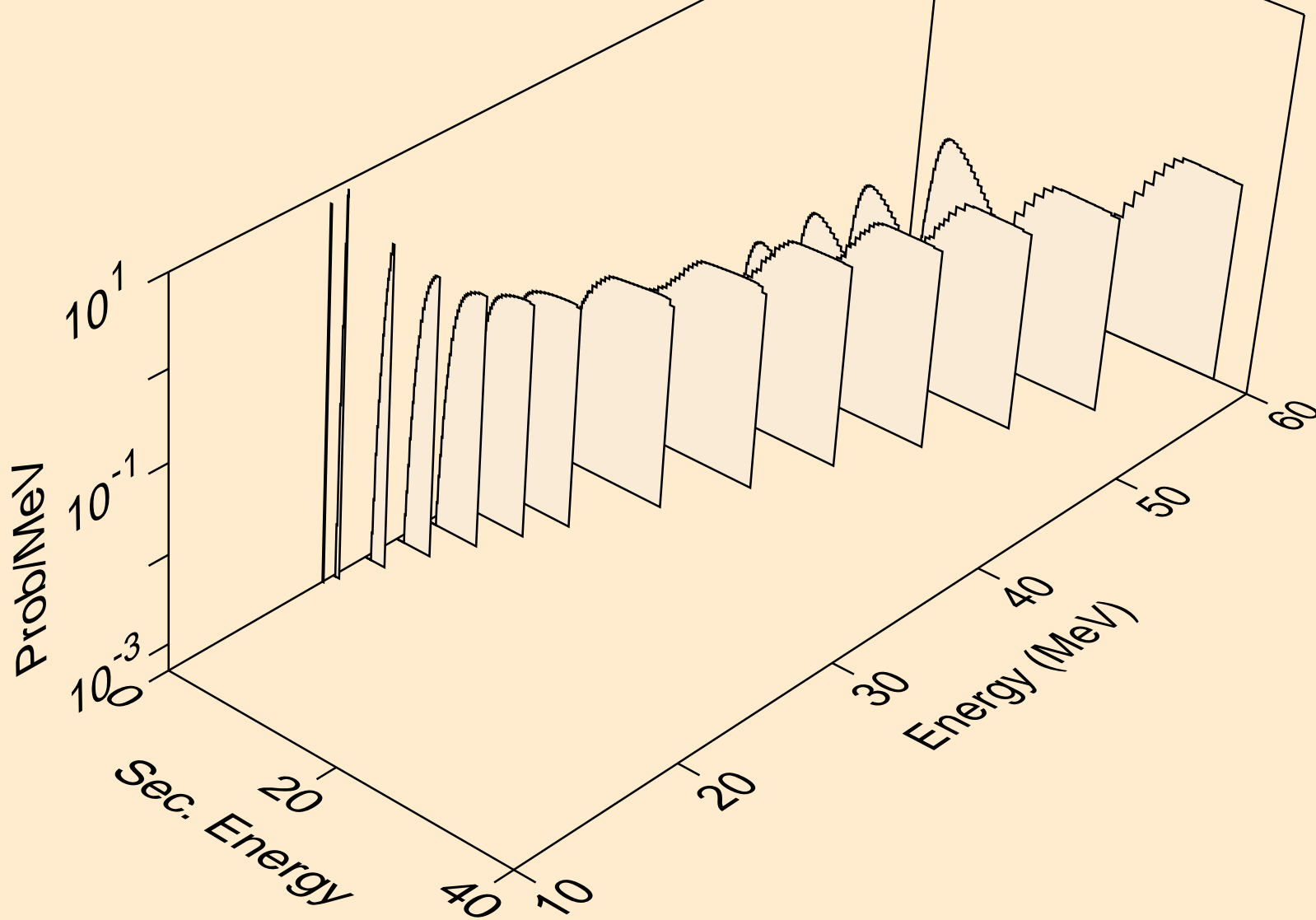

16-S-34 FOR FENDL-3.1 FROM TENDL-2010 WITH NJOY2012.50+
deuterons from (n,n*)d2a

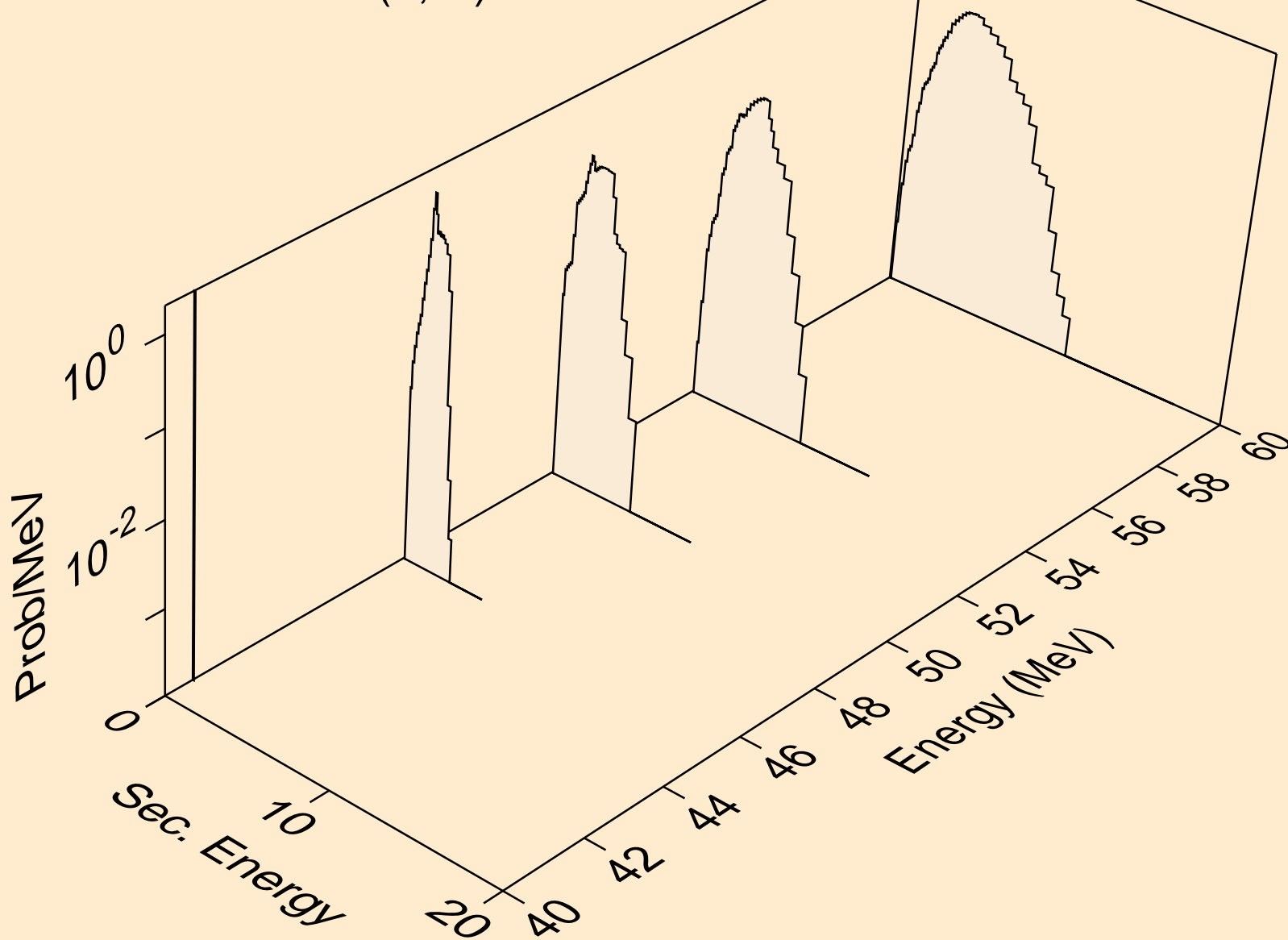

16-S-34 FOR FENDL-3.1 FROM TENDL-2010 WITH NJOY2012.50+
deuterons from (n,d)

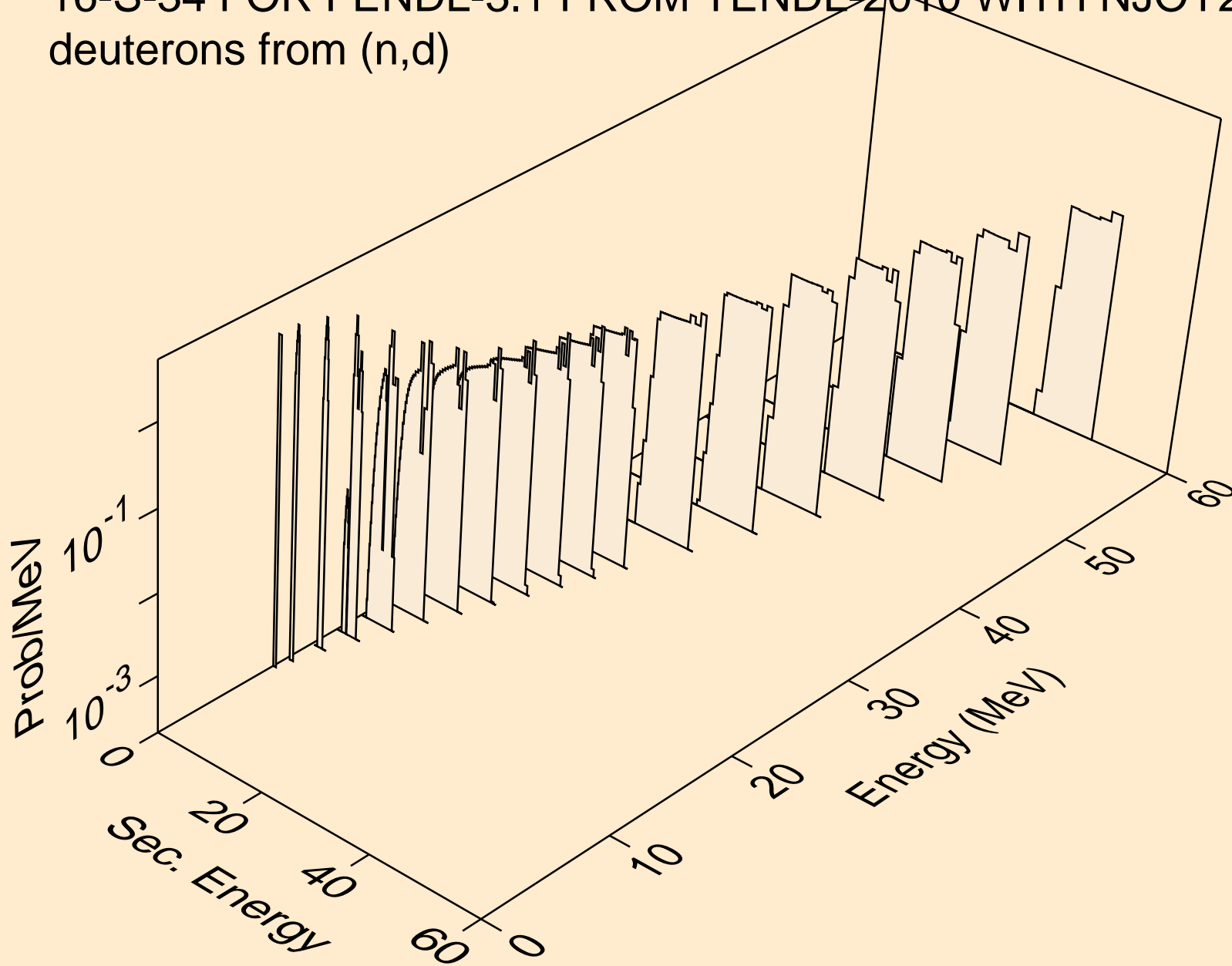

16-S-34 FOR FENDL-3.1 FROM TENDL-2010 WITH NJOY2012.50+
deuterons from (n,d2a)

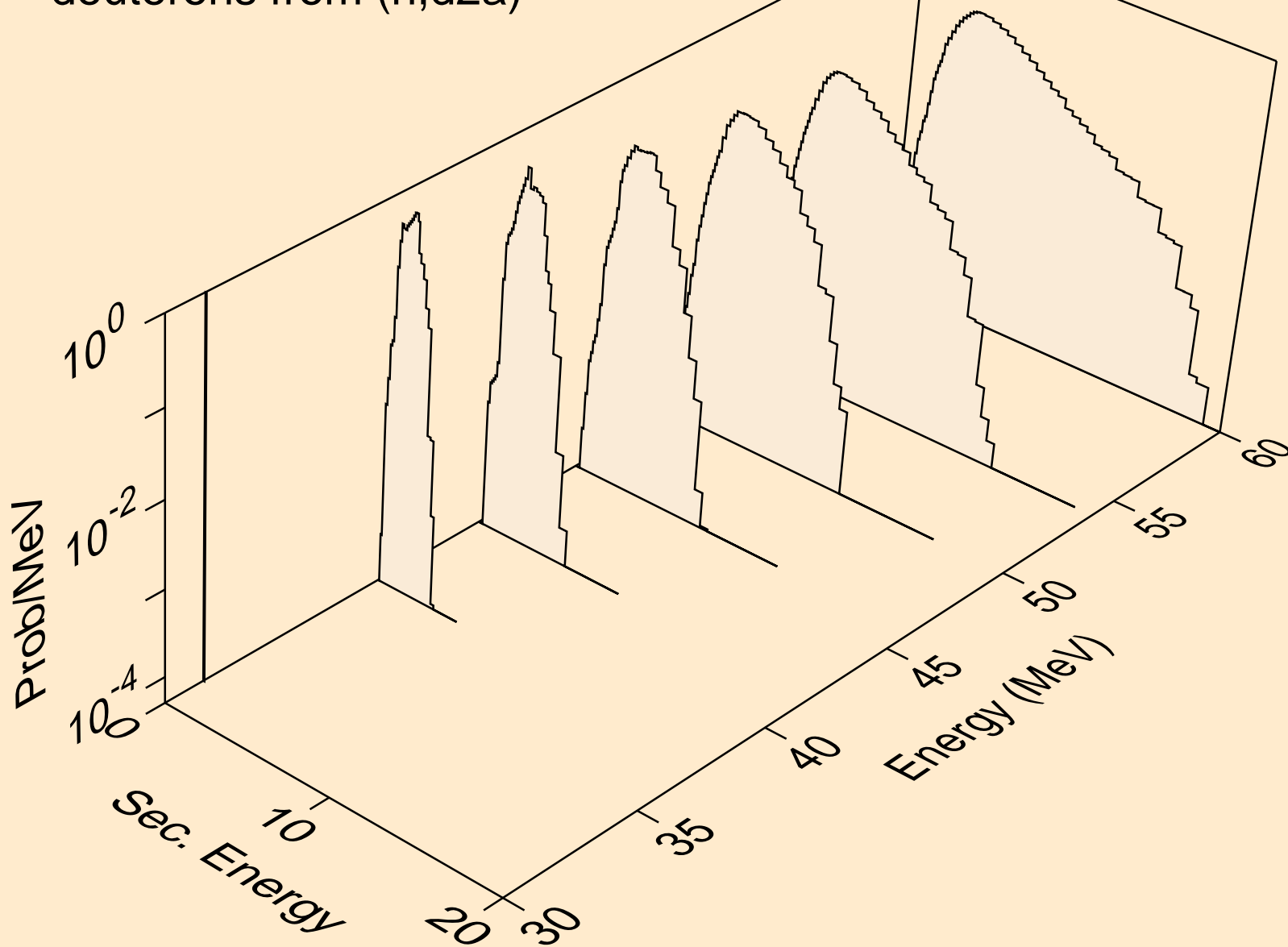

16-S-34 FOR FENDL-3.1 FROM TENDL-2010 WITH NJOY2012.50+
deuterons from (n,pd)

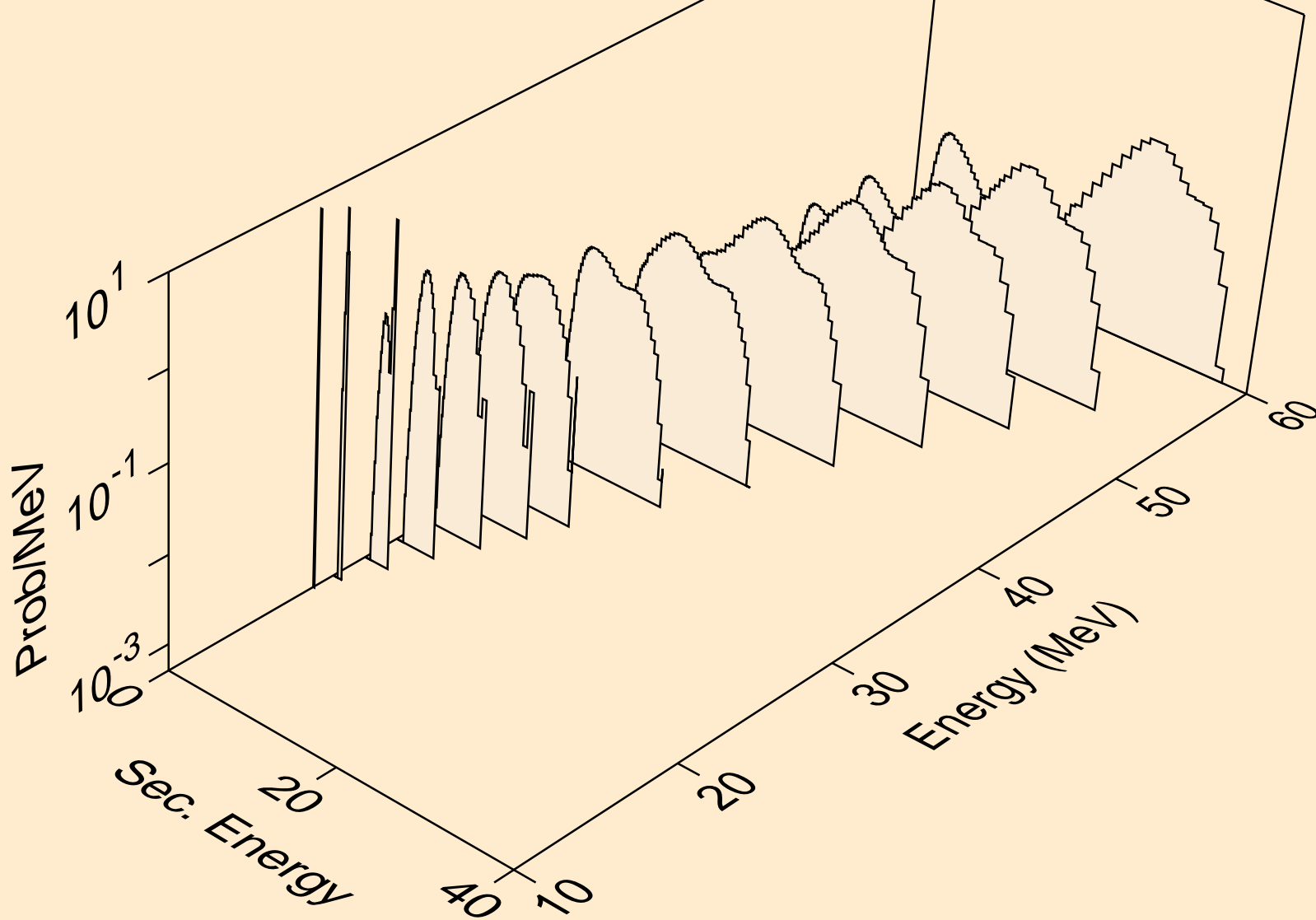

16-S-34 FOR FENDL-3.1 FROM TENDL-2010 WITH NJOY2012.50+
deuterons from (n,da)

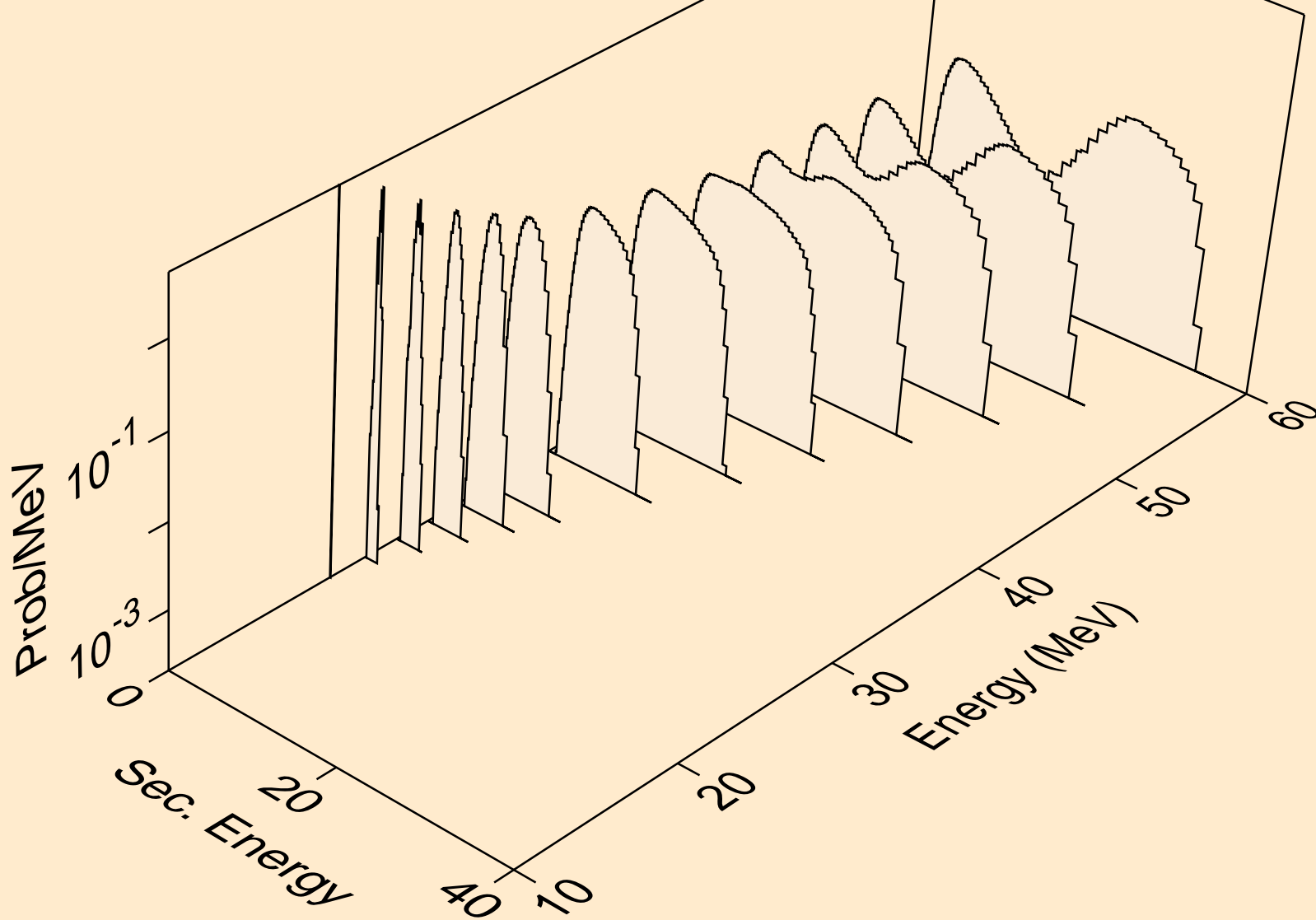

16-S-34 FOR FENDL-3.1 FROM TENDL-2010 WITH NJOY2012.50+
deuterons from (n,3nd)

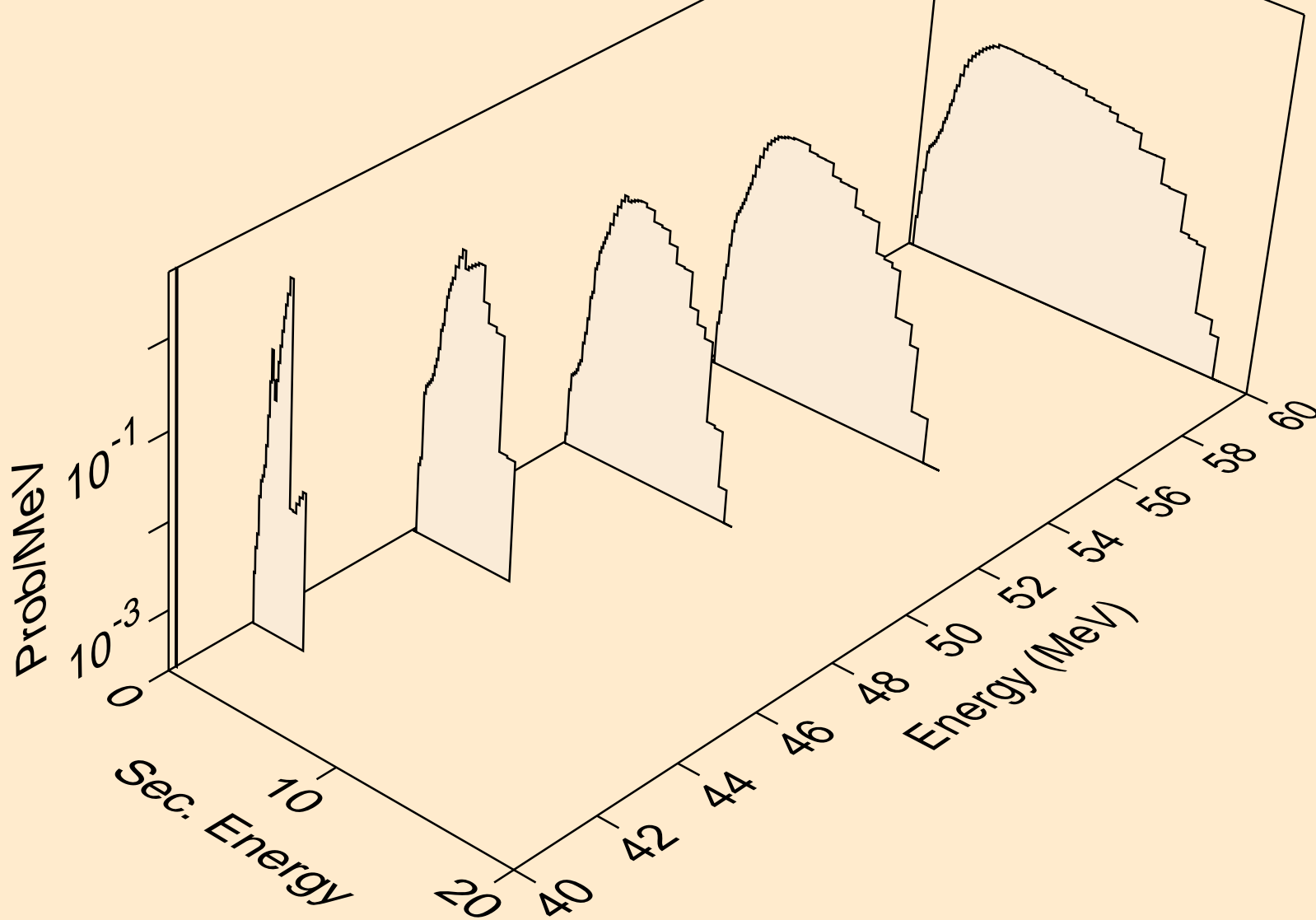

16-S-34 FOR FENDL-3.1 FROM TENDL-2010 WITH NJOY2012.50+
deuterons from (n,nda)

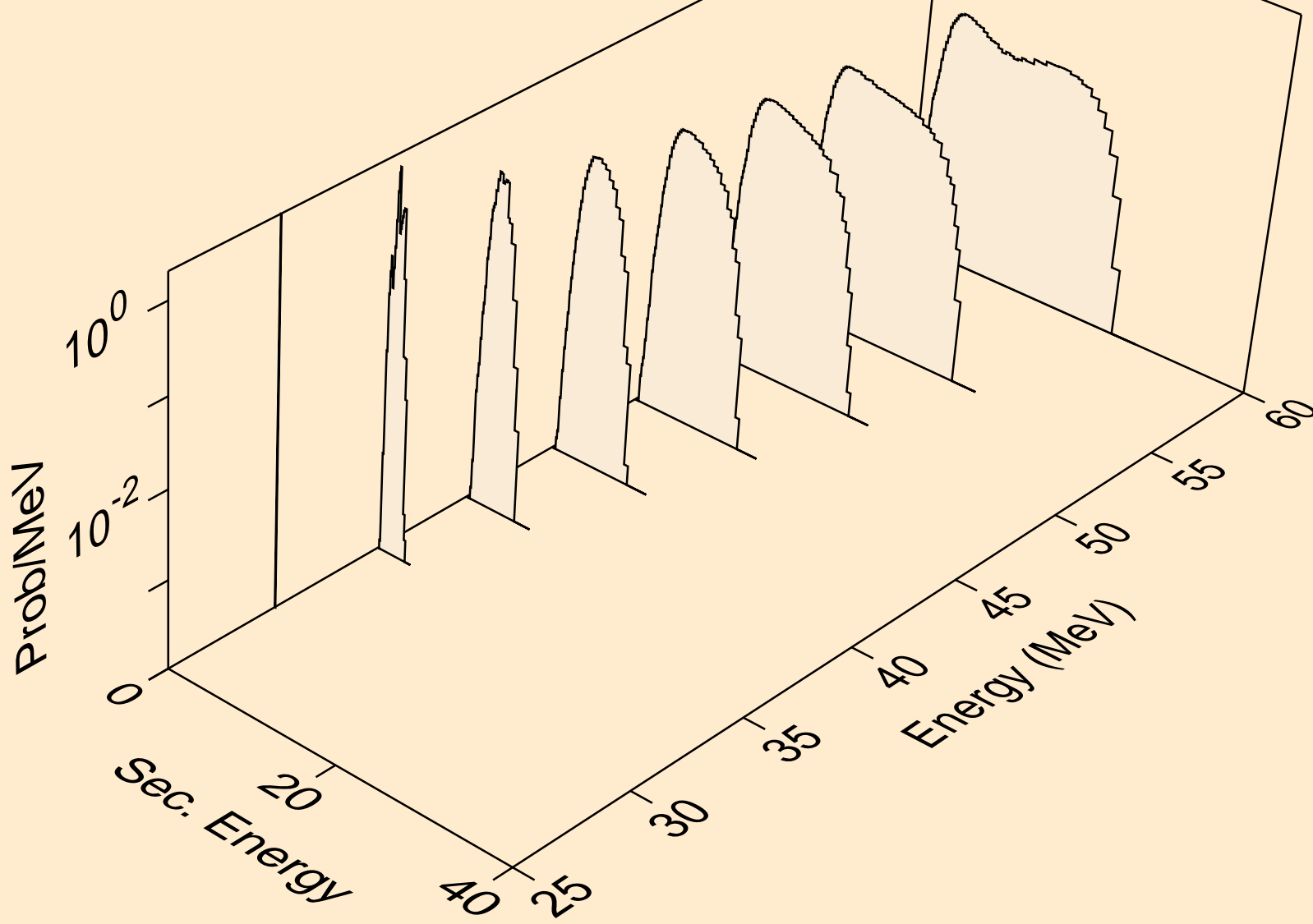

16-S-34 FOR FENDL-3.1 FROM TENDL-2010 WITH NJOY2012.50+
deuterons from (n,4nd)

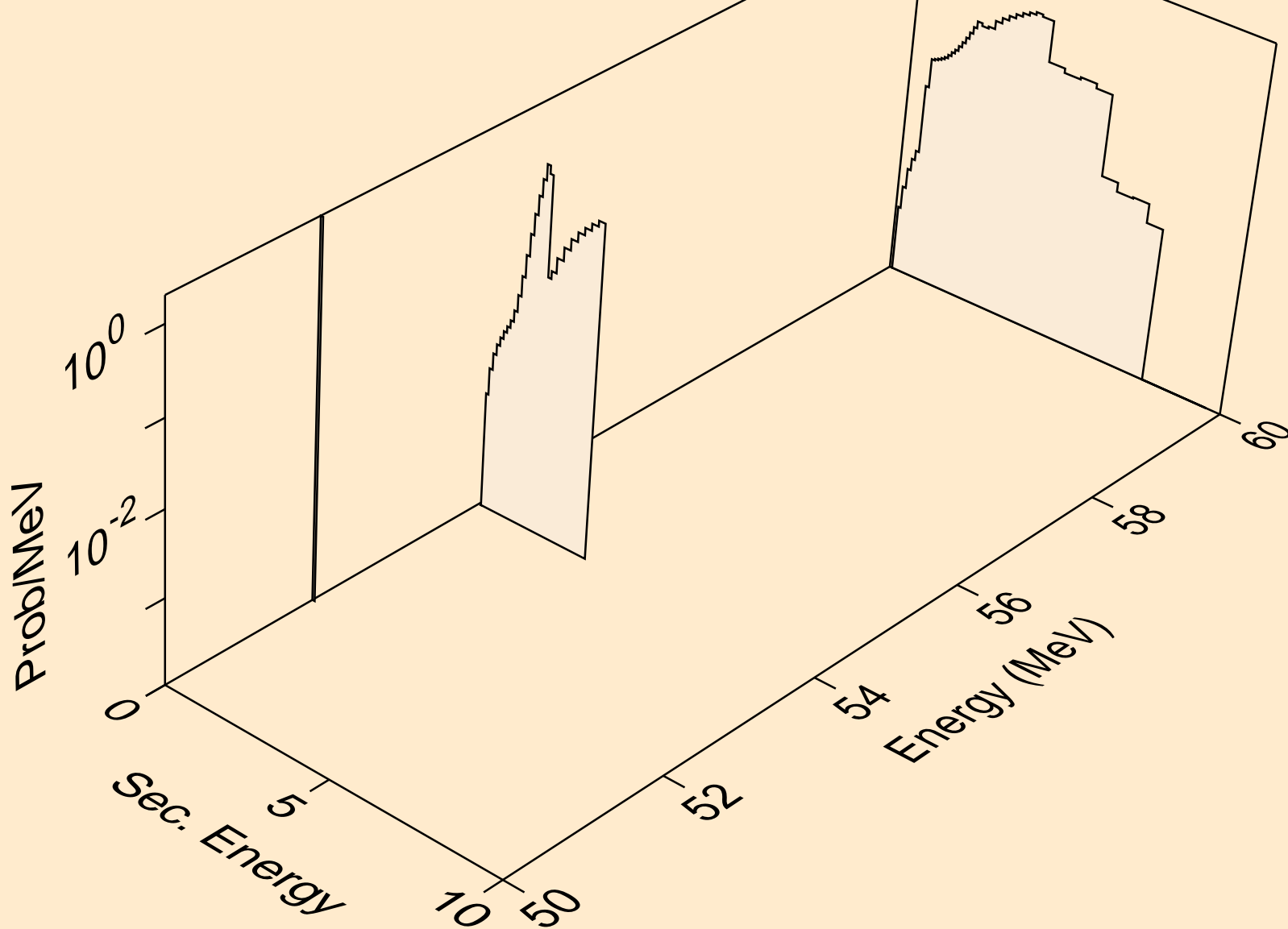

16-S-34 FOR FENDL-3.1 FROM TENDL-2010 WITH NJOY2012.50+
deuterons from (n,dt)

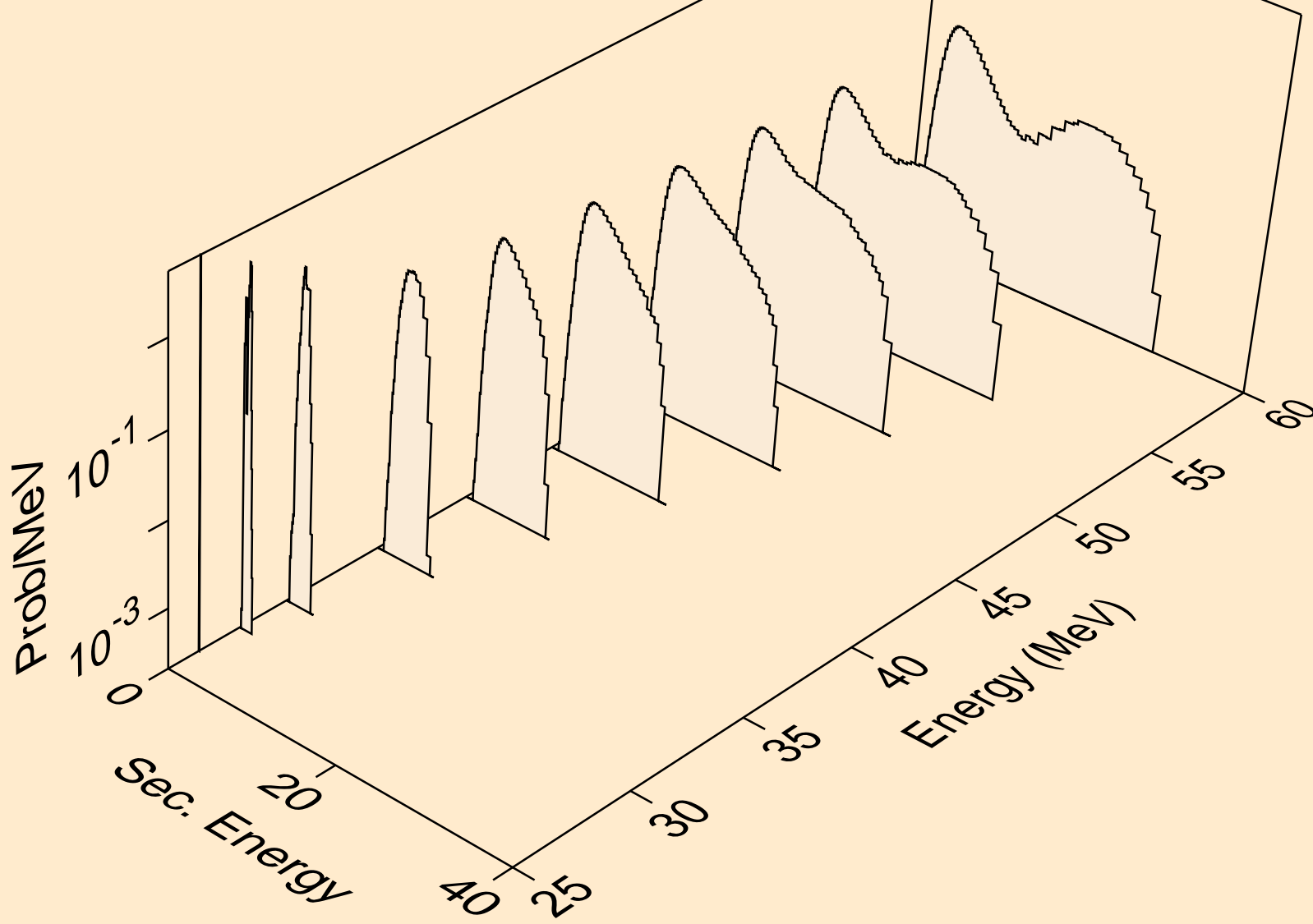

16-S-34 FOR FENDL-3.1 FROM TENDL-2010 WITH NJOY2012.50+
deuterons from (n,npd)

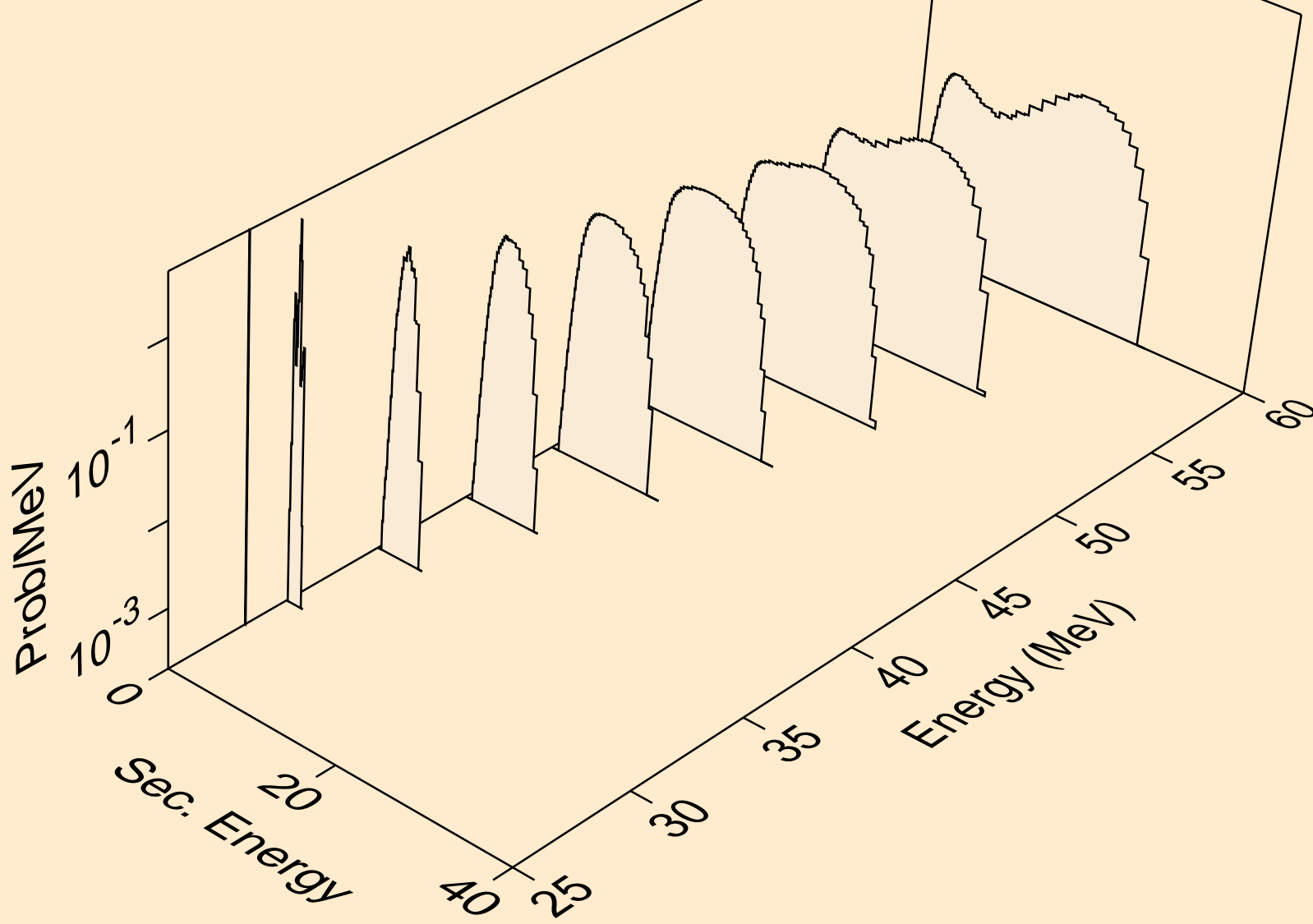

16-S-34 FOR FENDL-3.1 FROM TENDL-2010 WITH NJOY2012.50+
deuterons from (n,ndt)

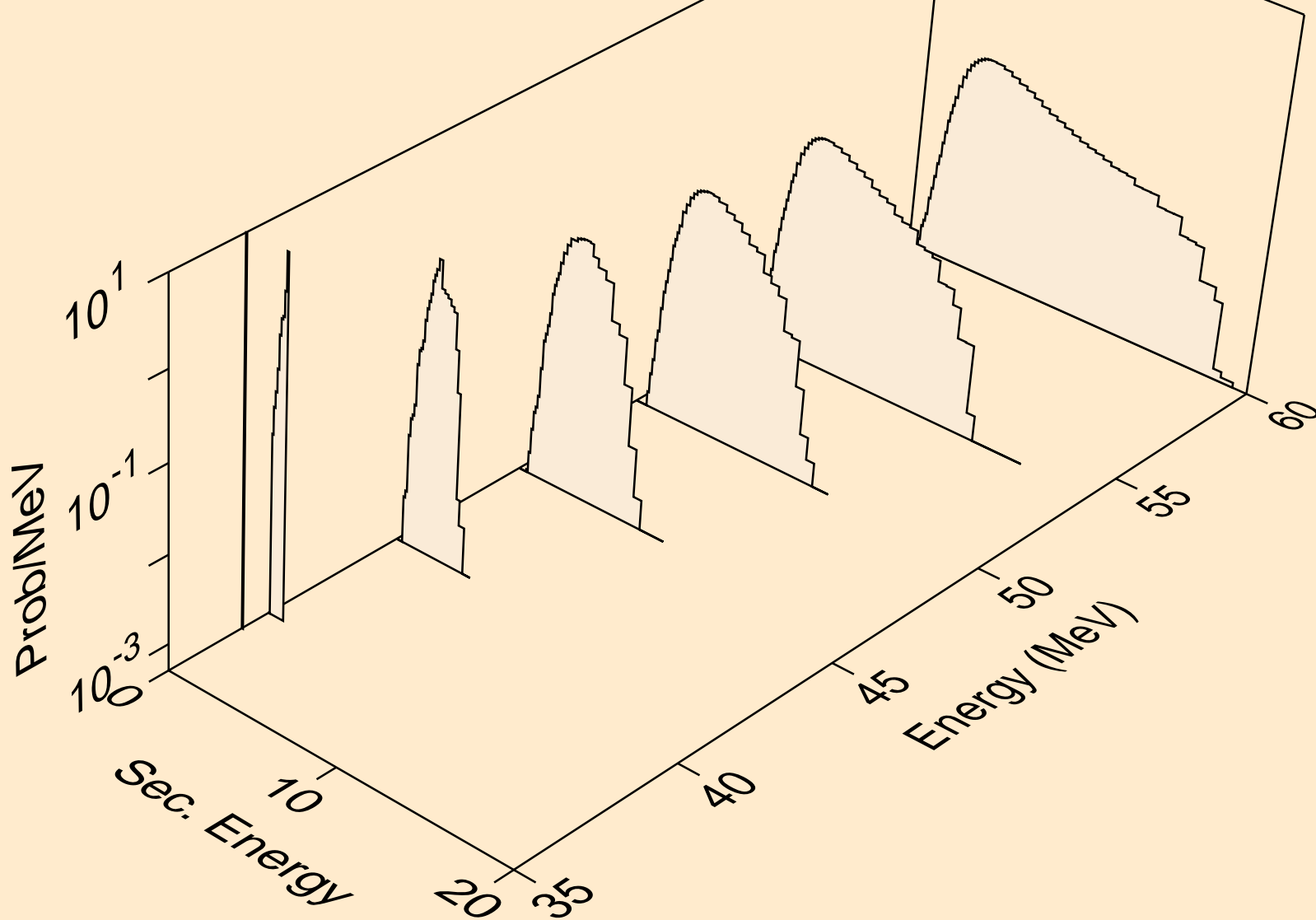

16-S-34 FOR FENDL-3.1 FROM TENDL-2010 WITH NJOY2012.50+
deuterons from (n,ndhe3)

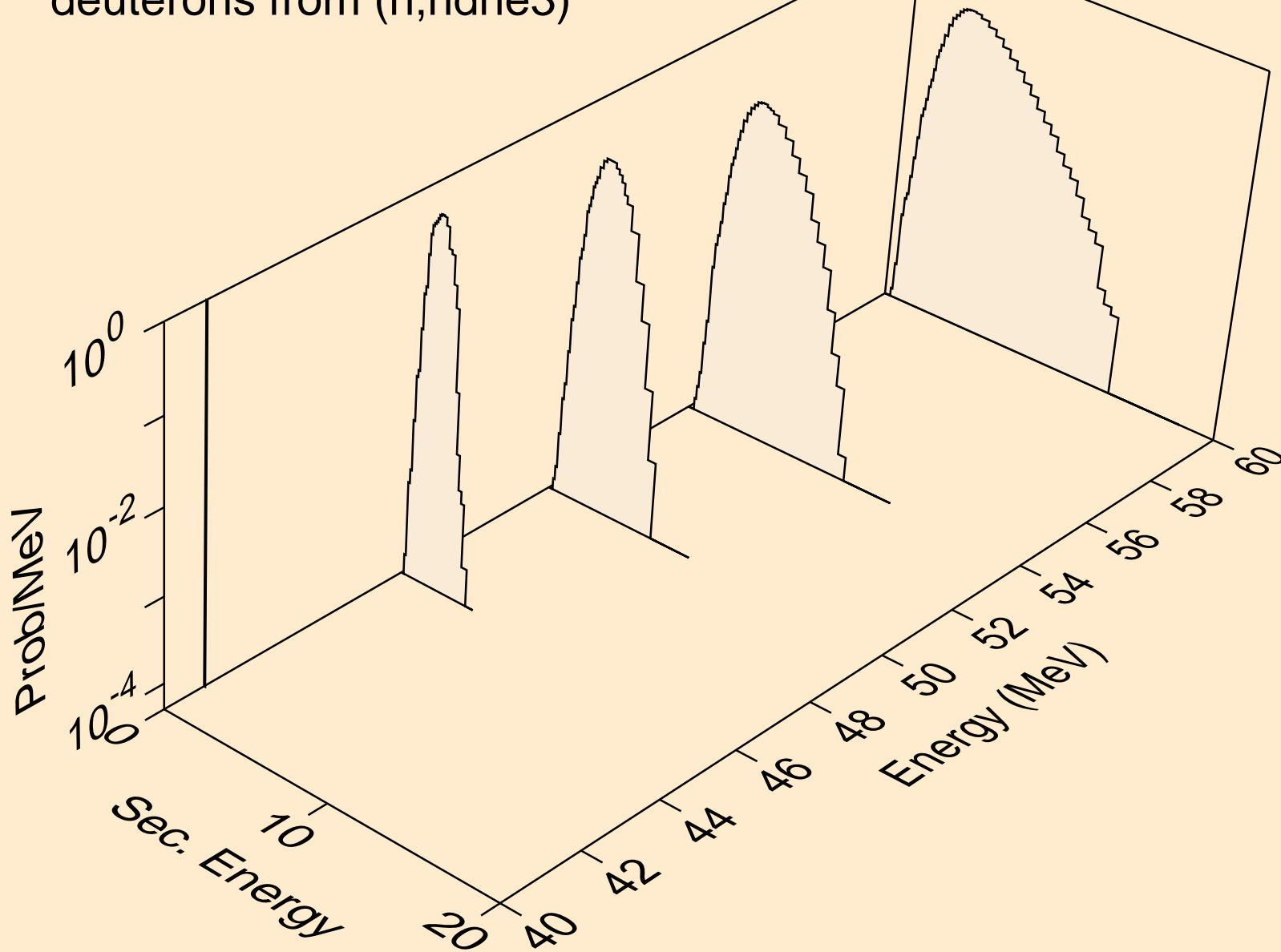

16-S-34 FOR FENDL-3.1 FROM TENDL-2010 WITH NJOY2012.50+
deuterons from (n,dhe3)

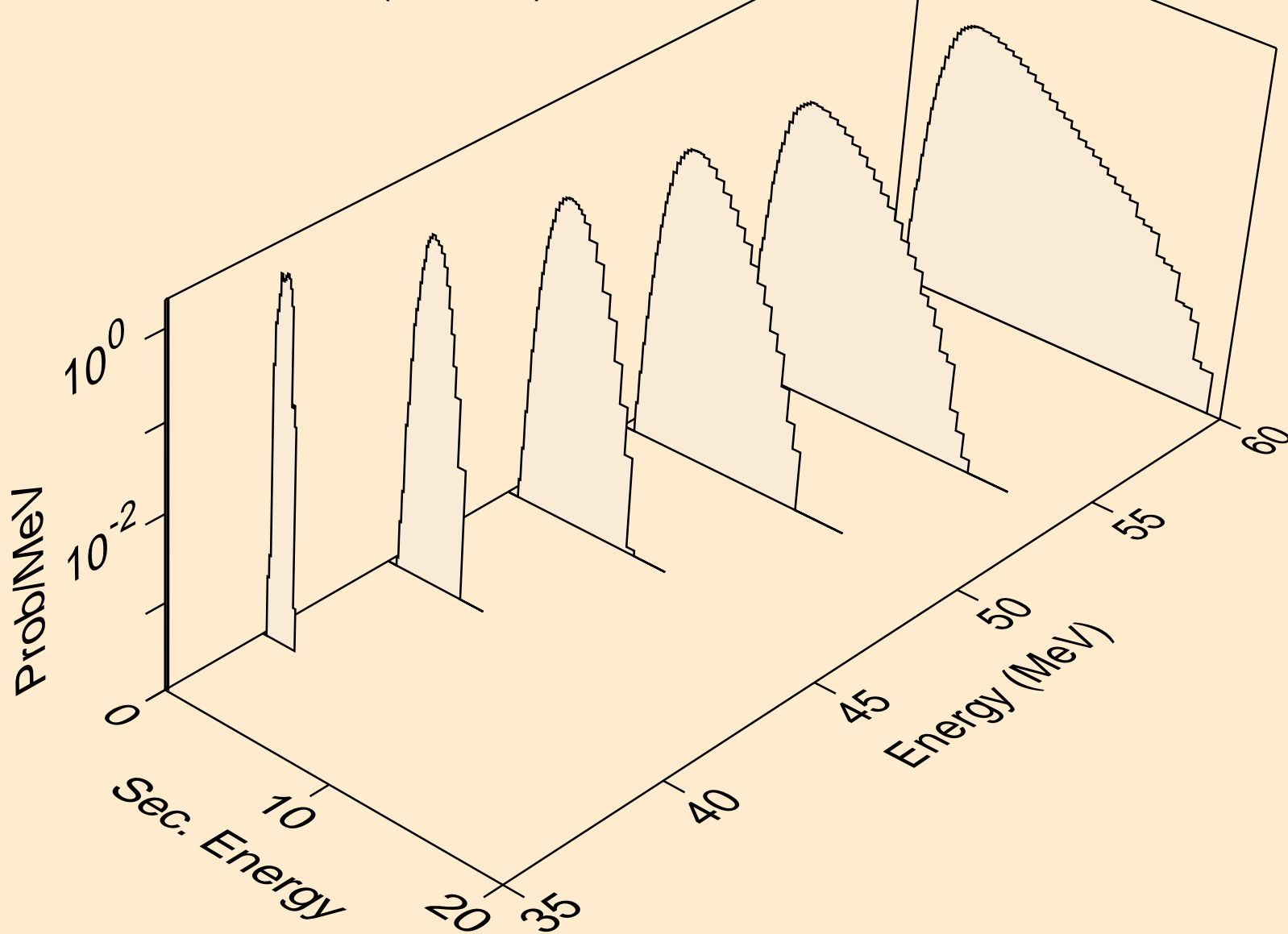

16-S-34 FOR FENDL-3.1 FROM TENDL-2010 WITH NJOY2012.50+
tritons from (n,x)

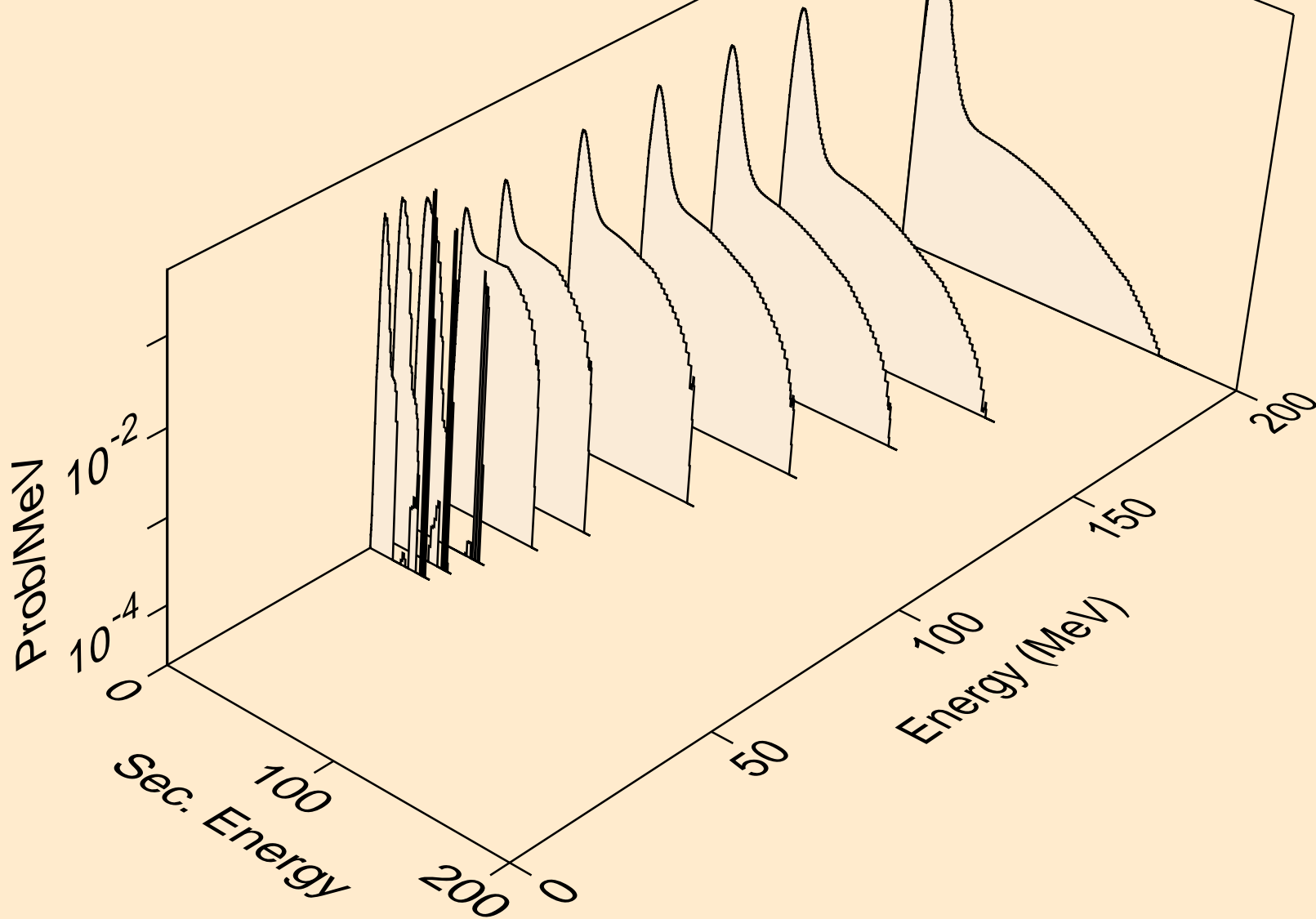

16-S-34 FOR FENDL-3.1 FROM TENDL-2010 WITH NJOY2012.50+
tritons from (n,n*)t

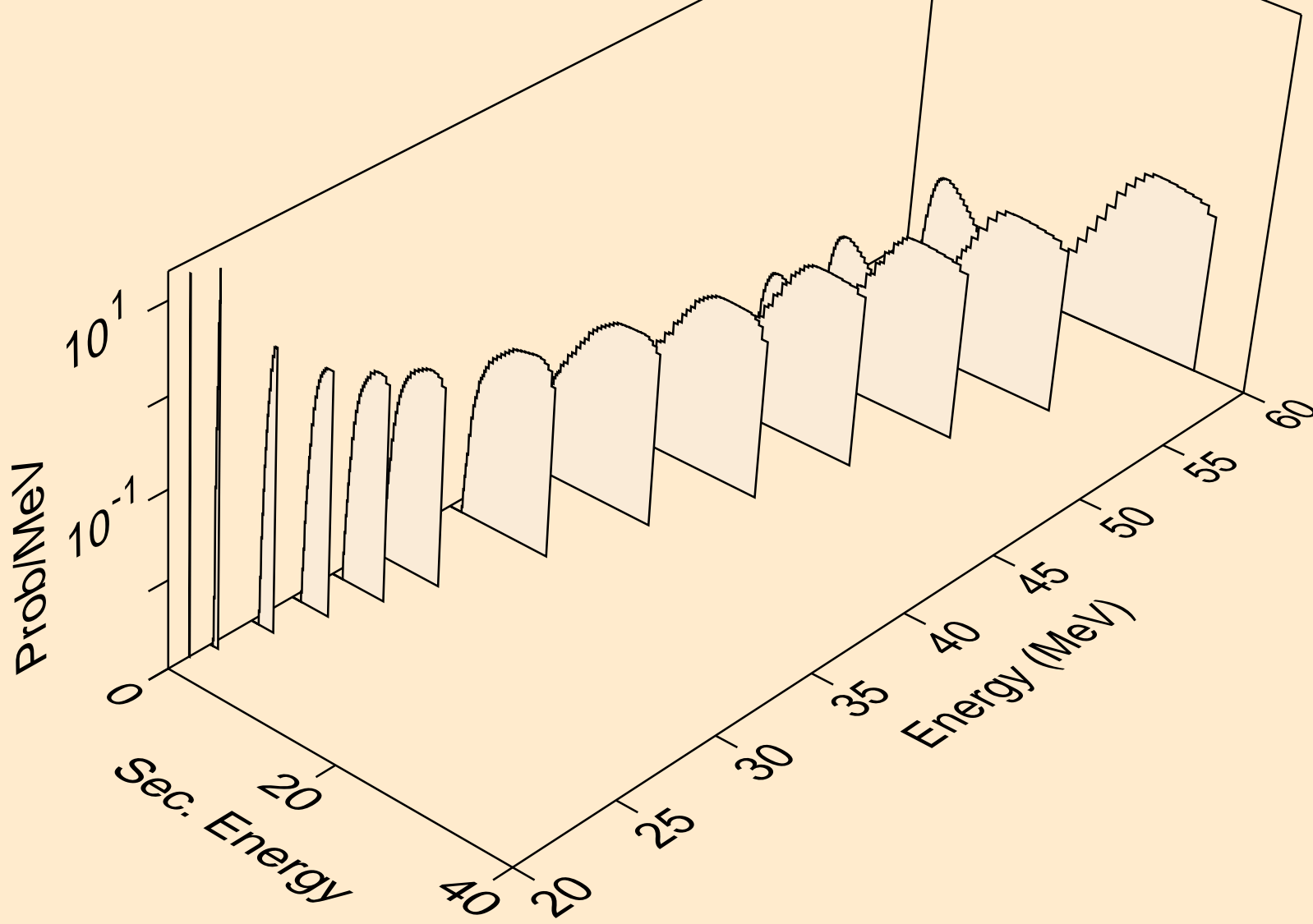

16-S-34 FOR FENDL-3.1 FROM TENDL-2010 WITH NJOY2012.50+
tritons from (n,n*)t2a

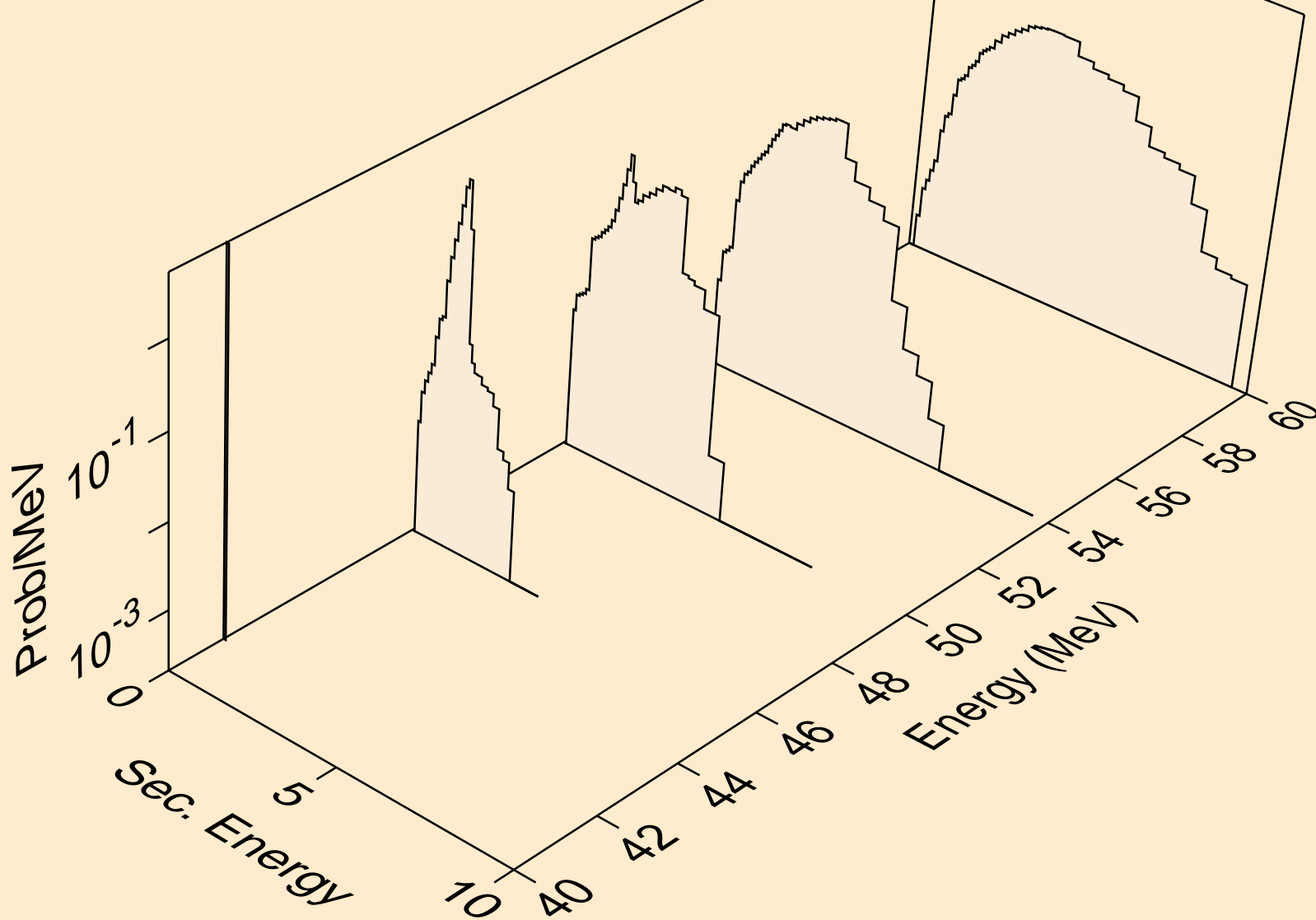

16-S-34 FOR FENDL-3.1 FROM TENDL-2010 WITH NJOY2012.50+
tritons from (n,t)

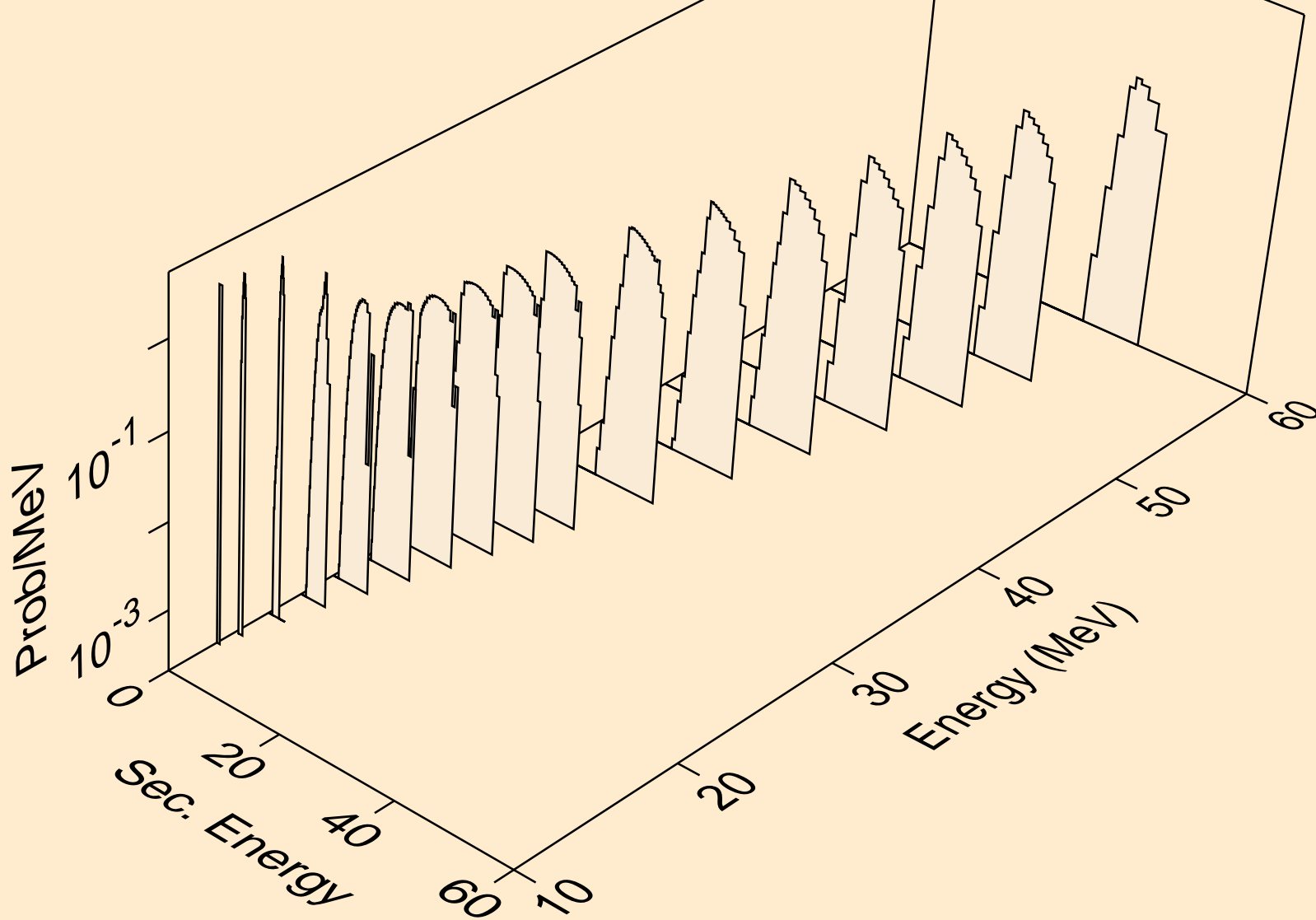

16-S-34 FOR FENDL-3.1 FROM TENDL-2010 WITH NJOY2012.50+
tritons from (n,t2a)

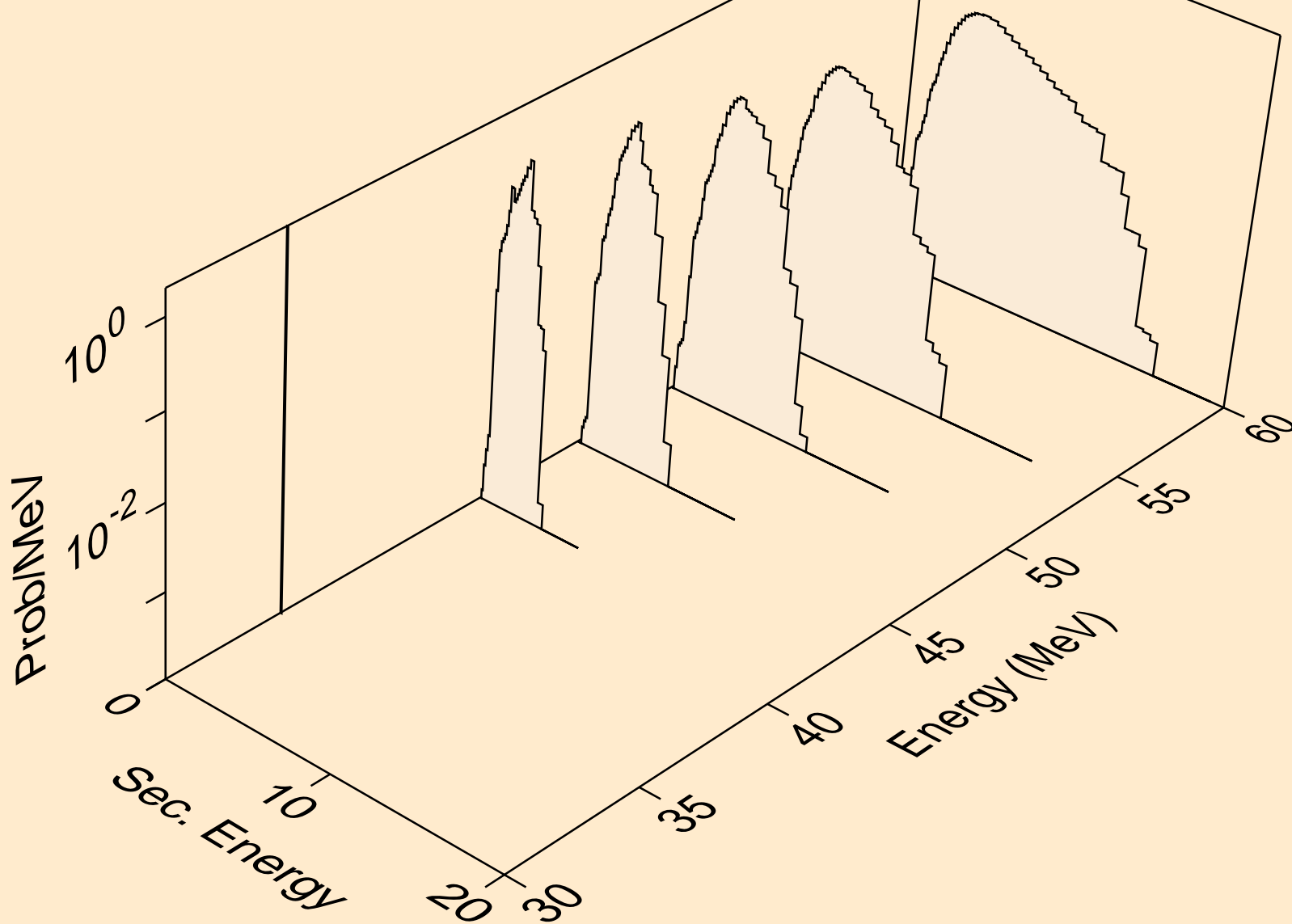

16-S-34 FOR FENDL-3.1 FROM TENDL-2010 WITH NJOY2012.50+
tritons from (n,pt)

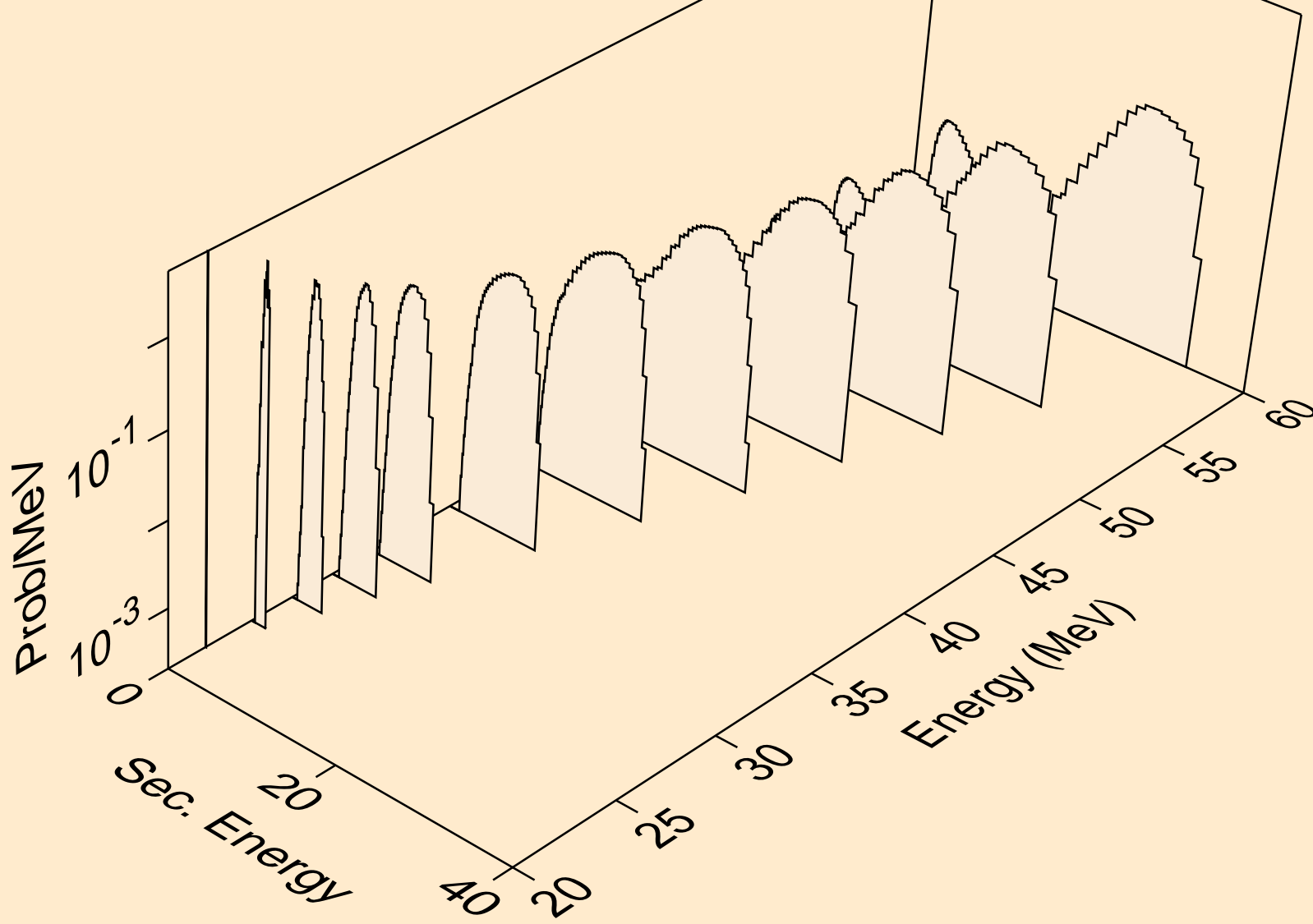

16-S-34 FOR FENDL-3.1 FROM TENDL-2010 WITH NJOY2012.50+
tritons from (n,2nt)

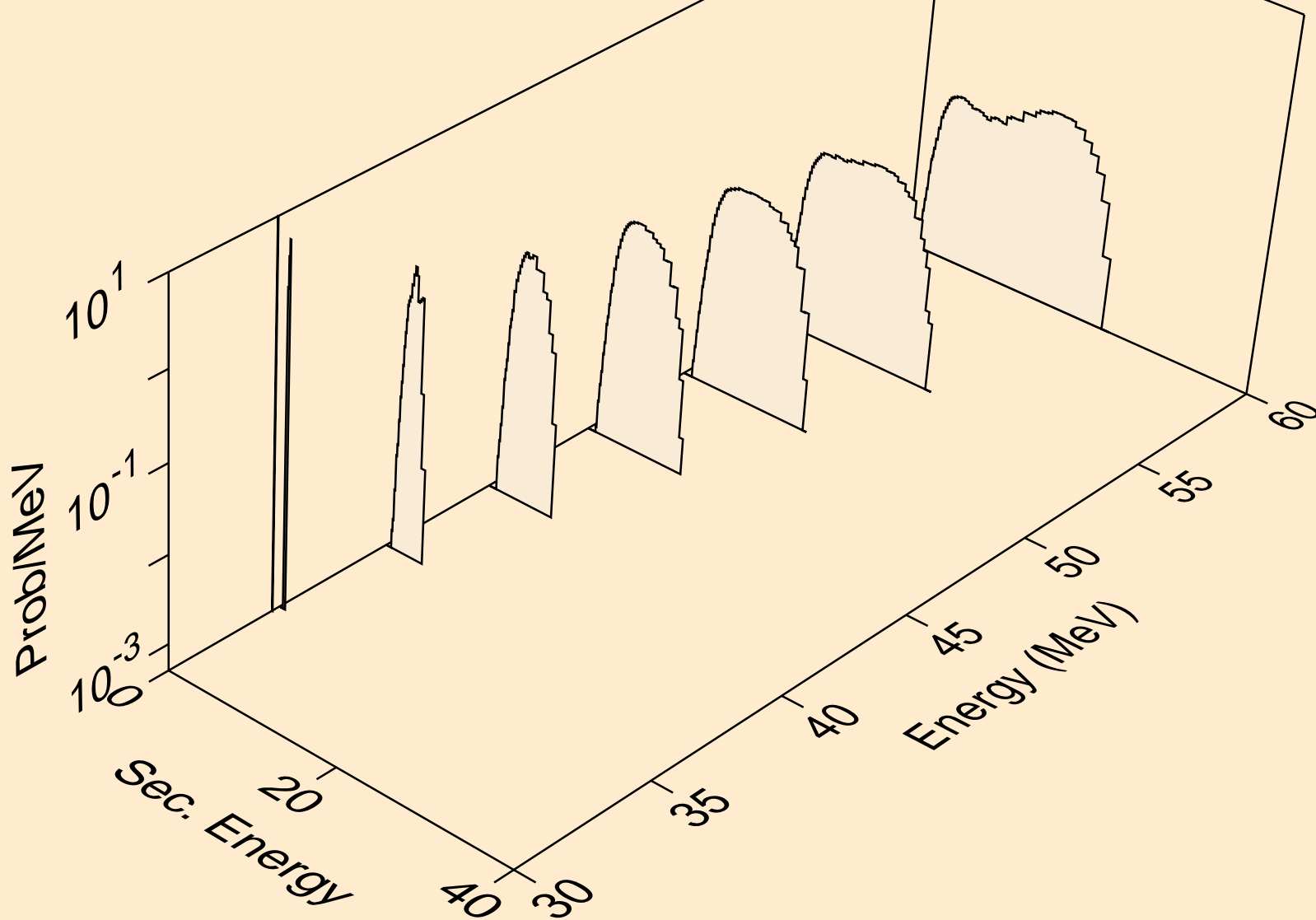

16-S-34 FOR FENDL-3.1 FROM TENDL-2010 WITH NJOY2012.50+
tritons from (n,ta)

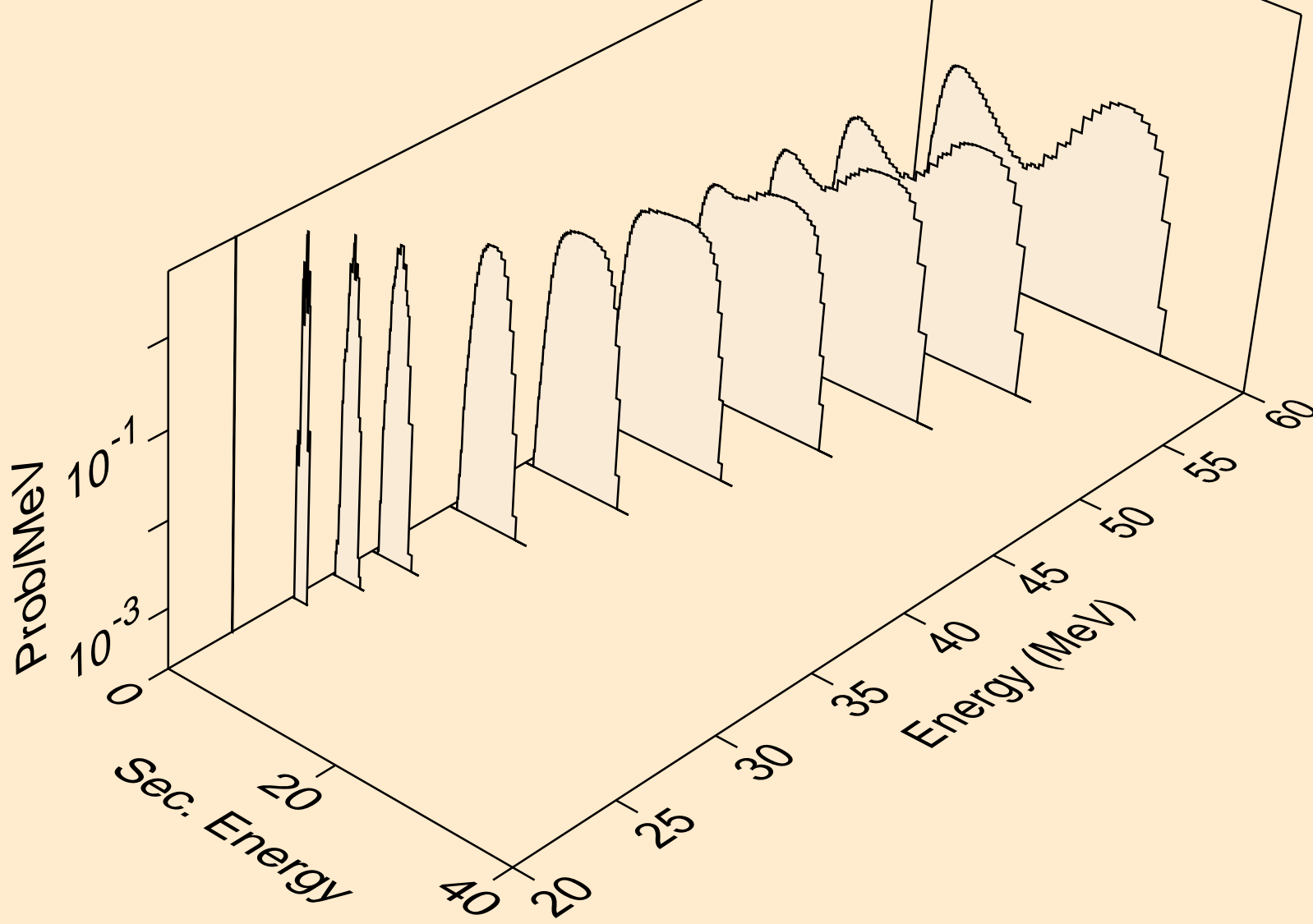

16-S-34 FOR FENDL-3.1 FROM TENDL-2010 WITH NJOY2012.50+
tritons from (n,3nt)

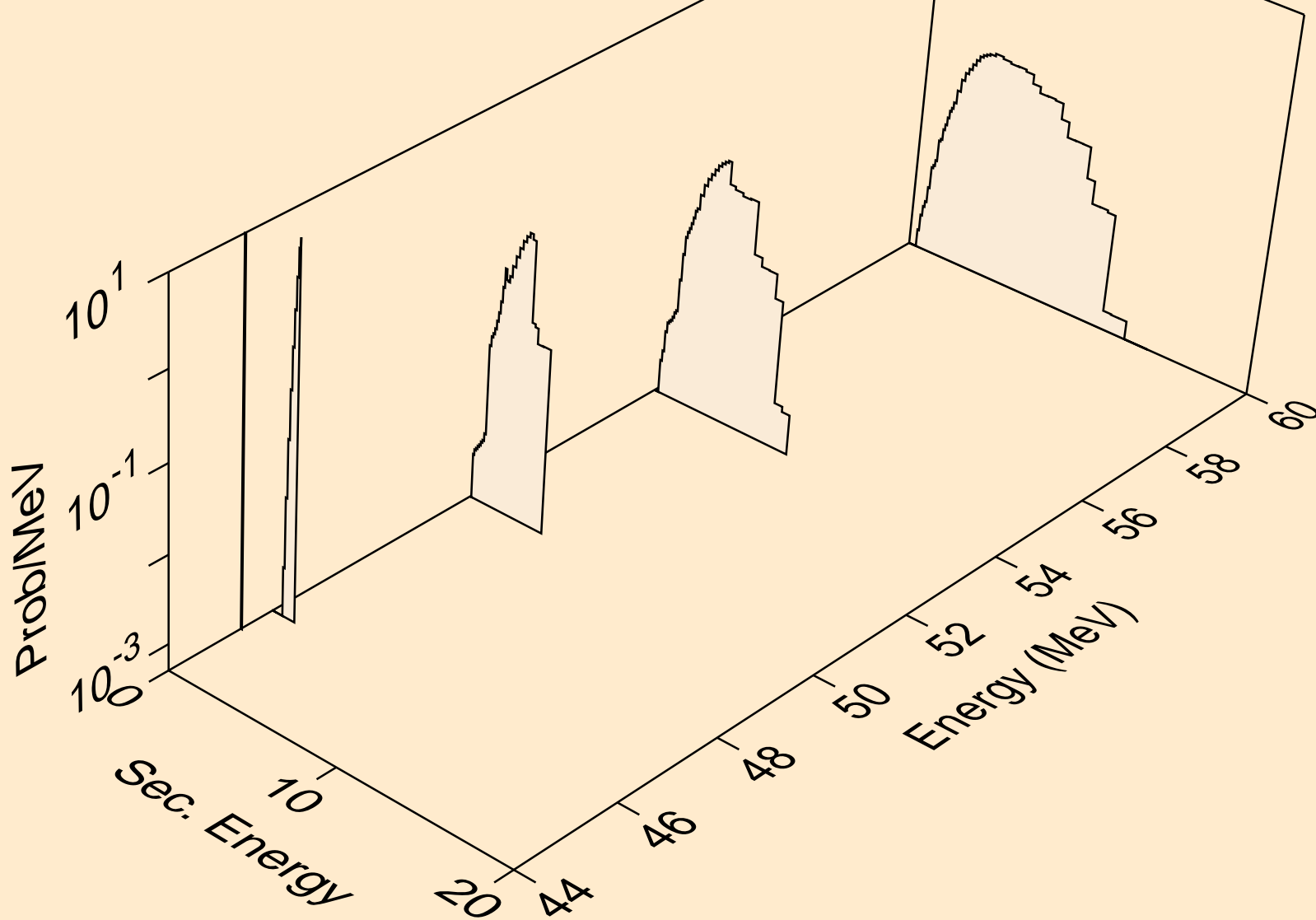

16-S-34 FOR FENDL-3.1 FROM TENDL-2010 WITH NJOY2012.50+
tritons from (n,dt)

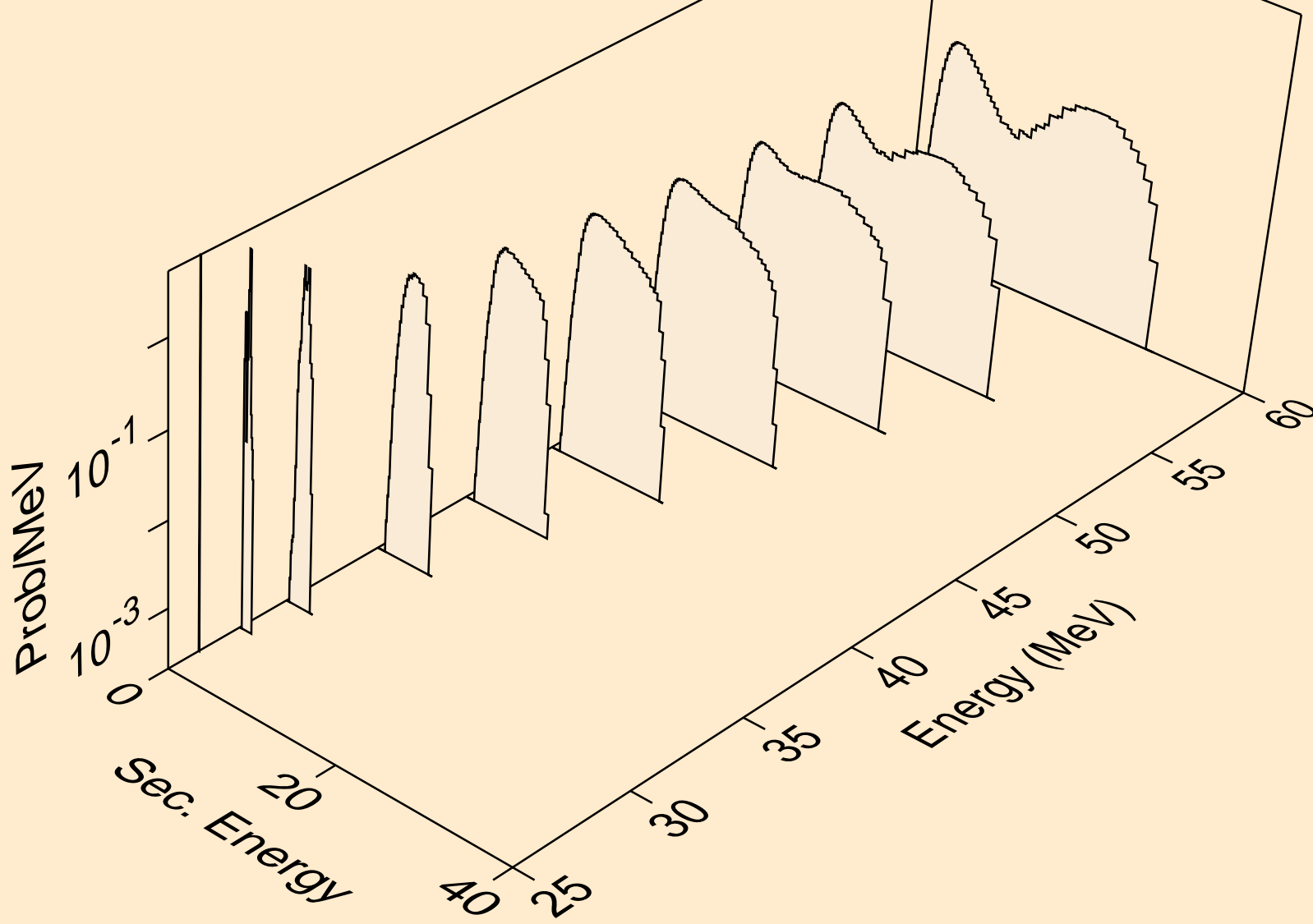

16-S-34 FOR FENDL-3.1 FROM TENDL-2010 WITH NJOY2012.50+
tritons from (n,npt)

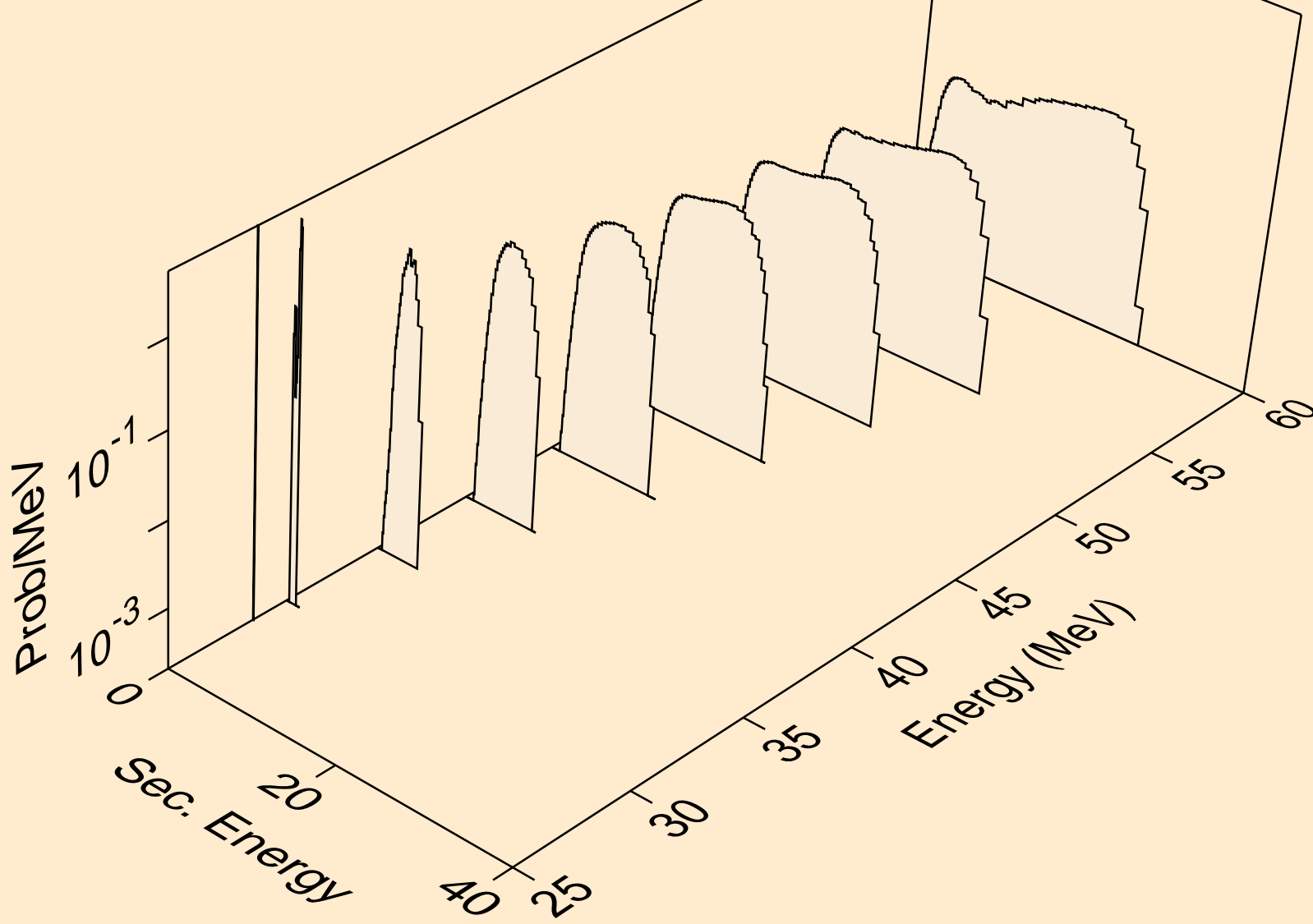

16-S-34 FOR FENDL-3.1 FROM TENDL-2010 WITH NJOY2012.50+
tritons from (n,ndt)

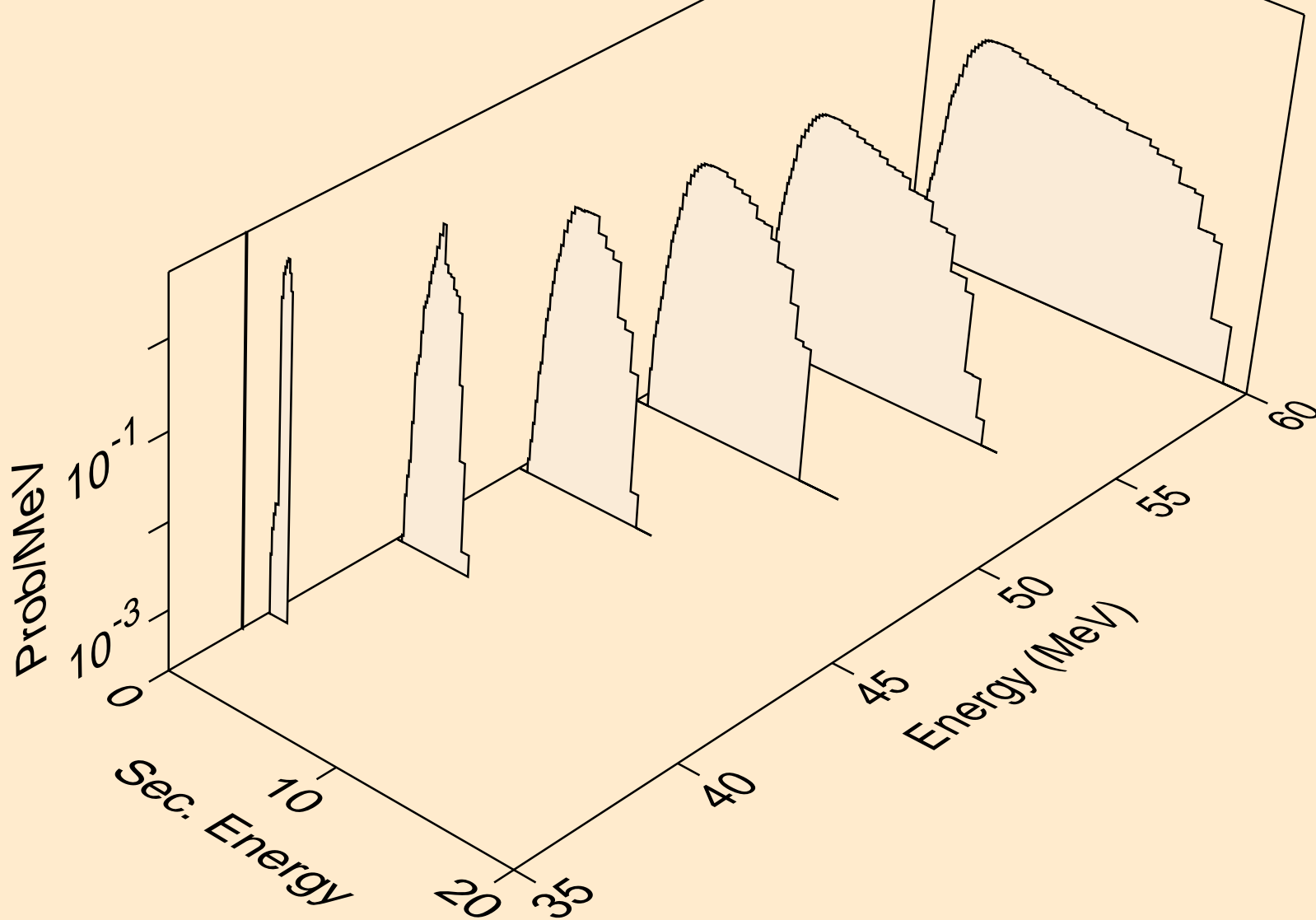

16-S-34 FOR FENDL-3.1 FROM TENDL-2010 WITH NJOY2012.50+
tritons from (n,nthe3)

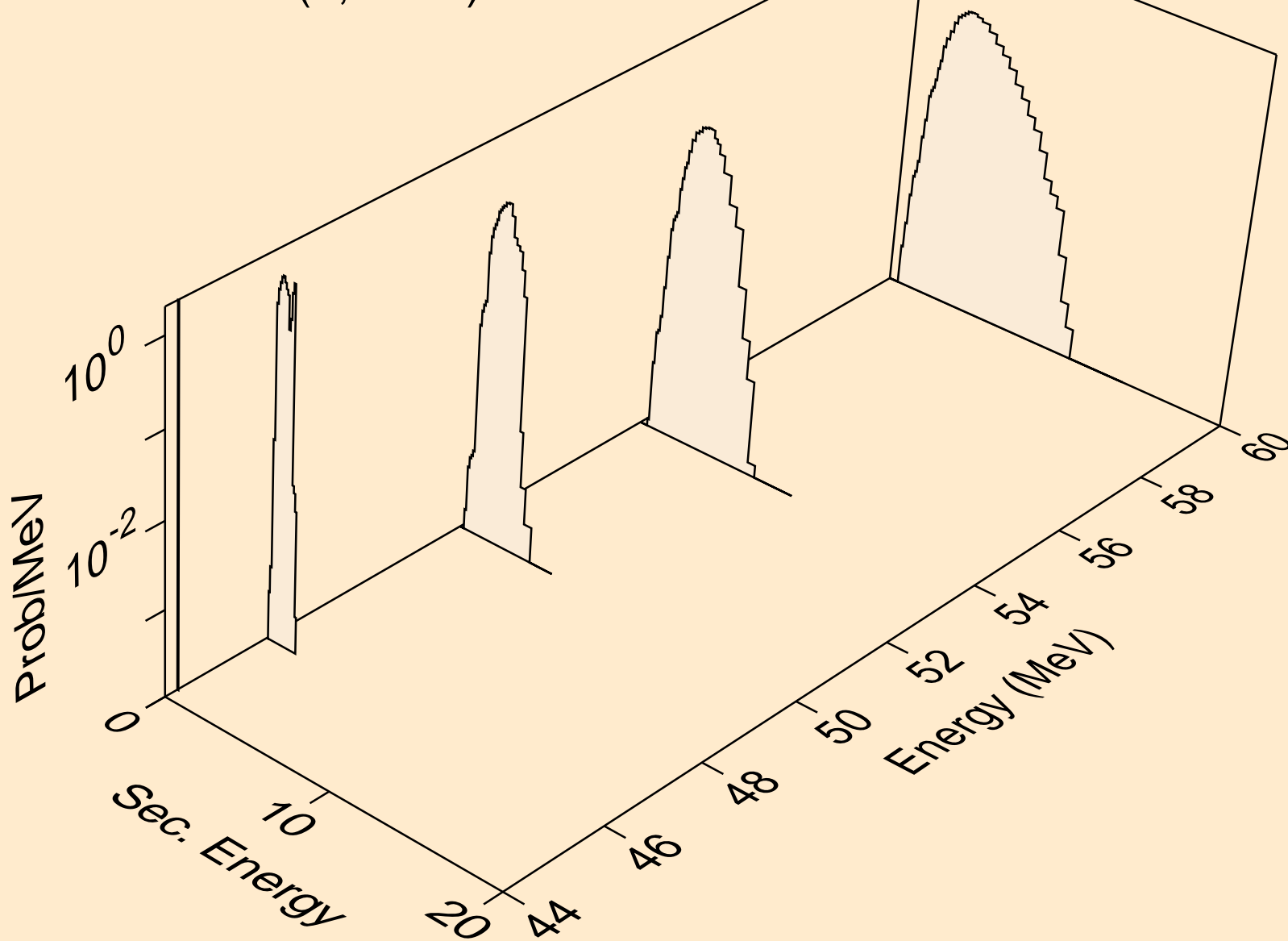

16-S-34 FOR FENDL-3.1 FROM TENDL-2010 WITH NJOY2012.50+
tritons from (n,nta)

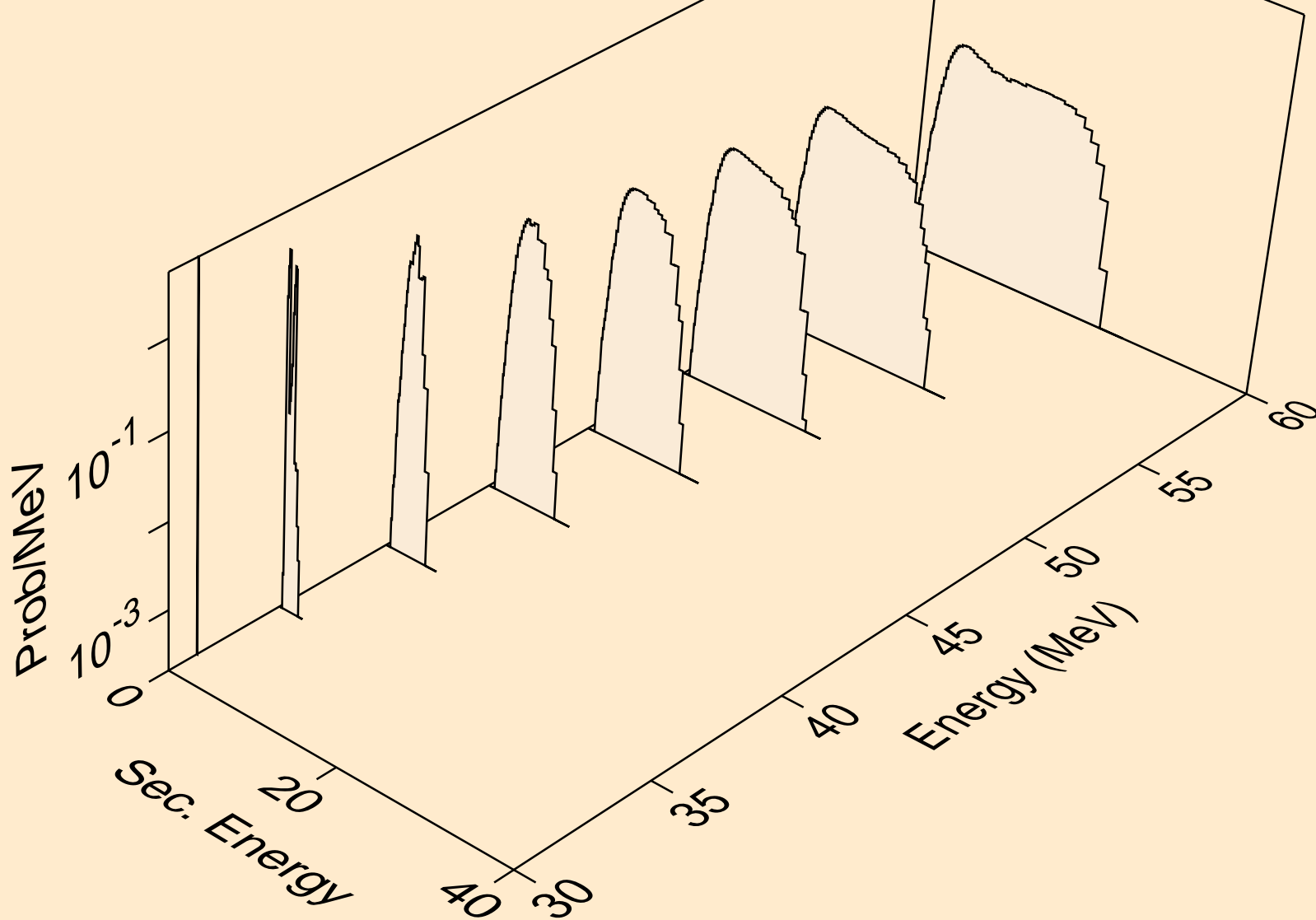

16-S-34 FOR FENDL-3.1 FROM TENDL-2010 WITH NJOY2012.50+
he3s from (n,x)

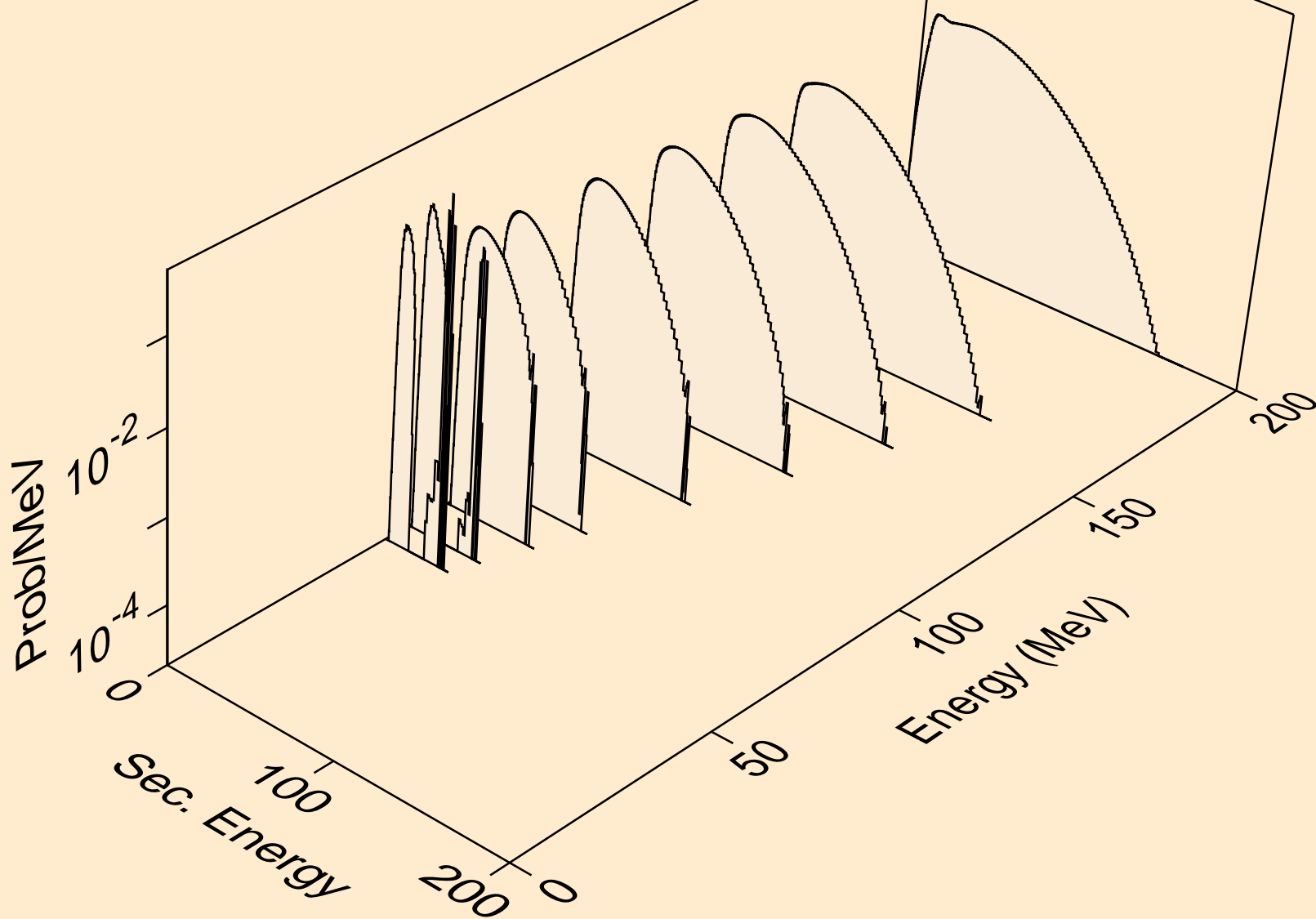

16-S-34 FOR FENDL-3.1 FROM TENDL-2010 WITH NJOY2012.50+
he3s from (n,n*)he3

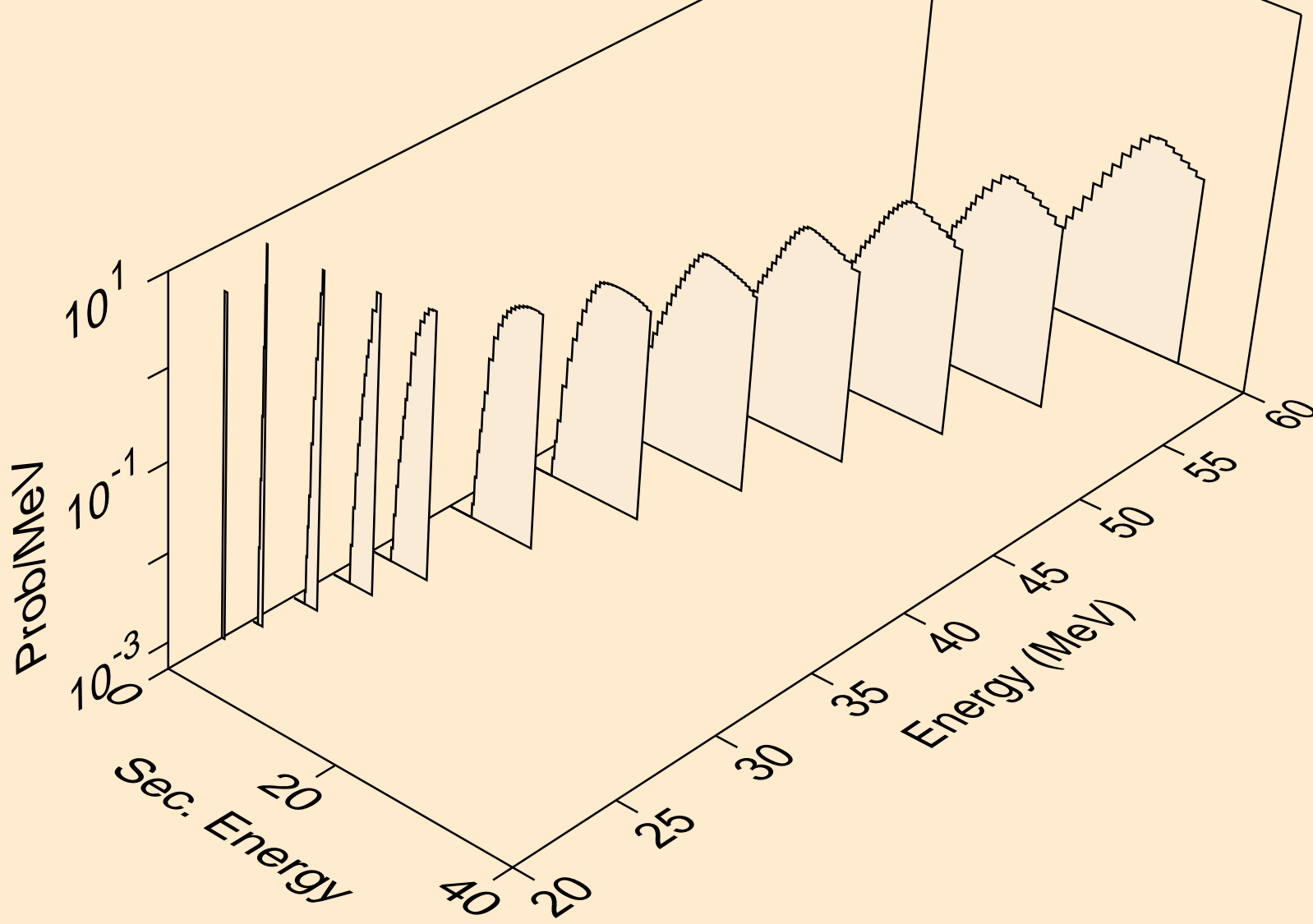

16-S-34 FOR FENDL-3.1 FROM TENDL-2010 WITH NJOY2012.50+
he3s from (n,he3)

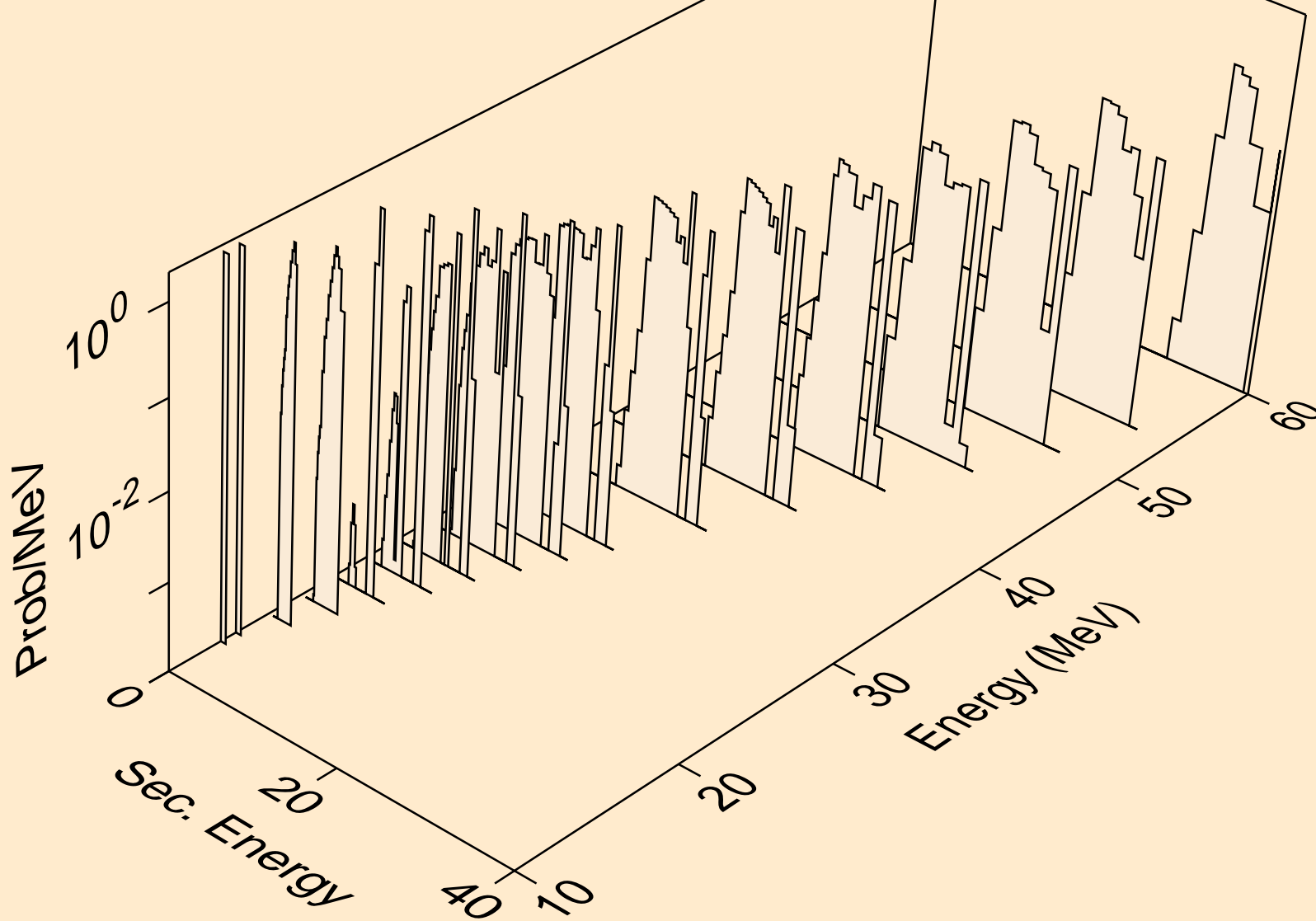

16-S-34 FOR FENDL-3.1 FROM TENDL-2010 WITH NJOY2012.50+
he3s from (n,2n)he3)

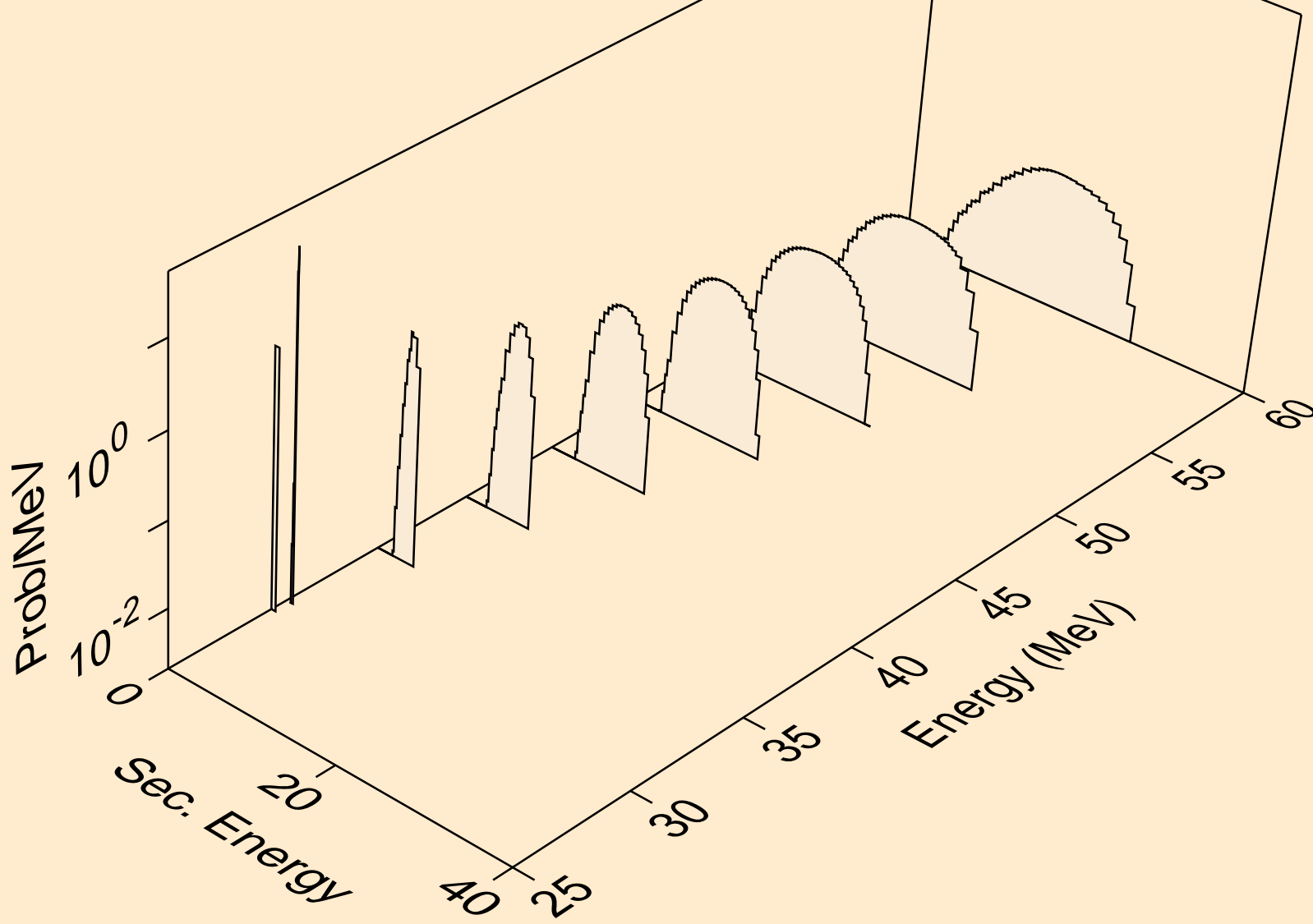

16-S-34 FOR FENDL-3.1 FROM TENDL-2010 WITH NJOY2012.50+
he3s from (n,3n)he3)

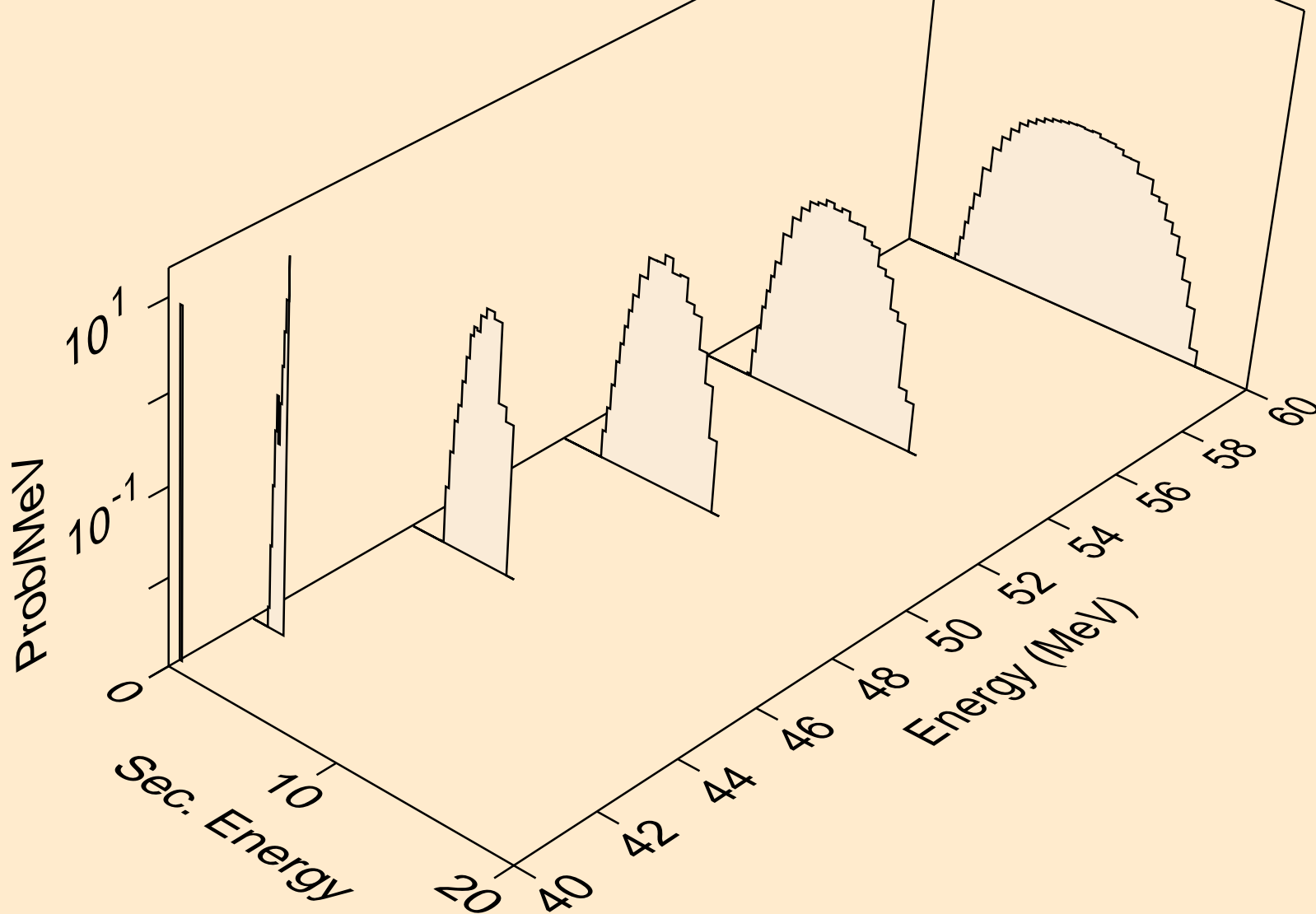

16-S-34 FOR FENDL-3.1 FROM TENDL-2010 WITH NJOY2012.50+
he3s from (n,4n)he3)

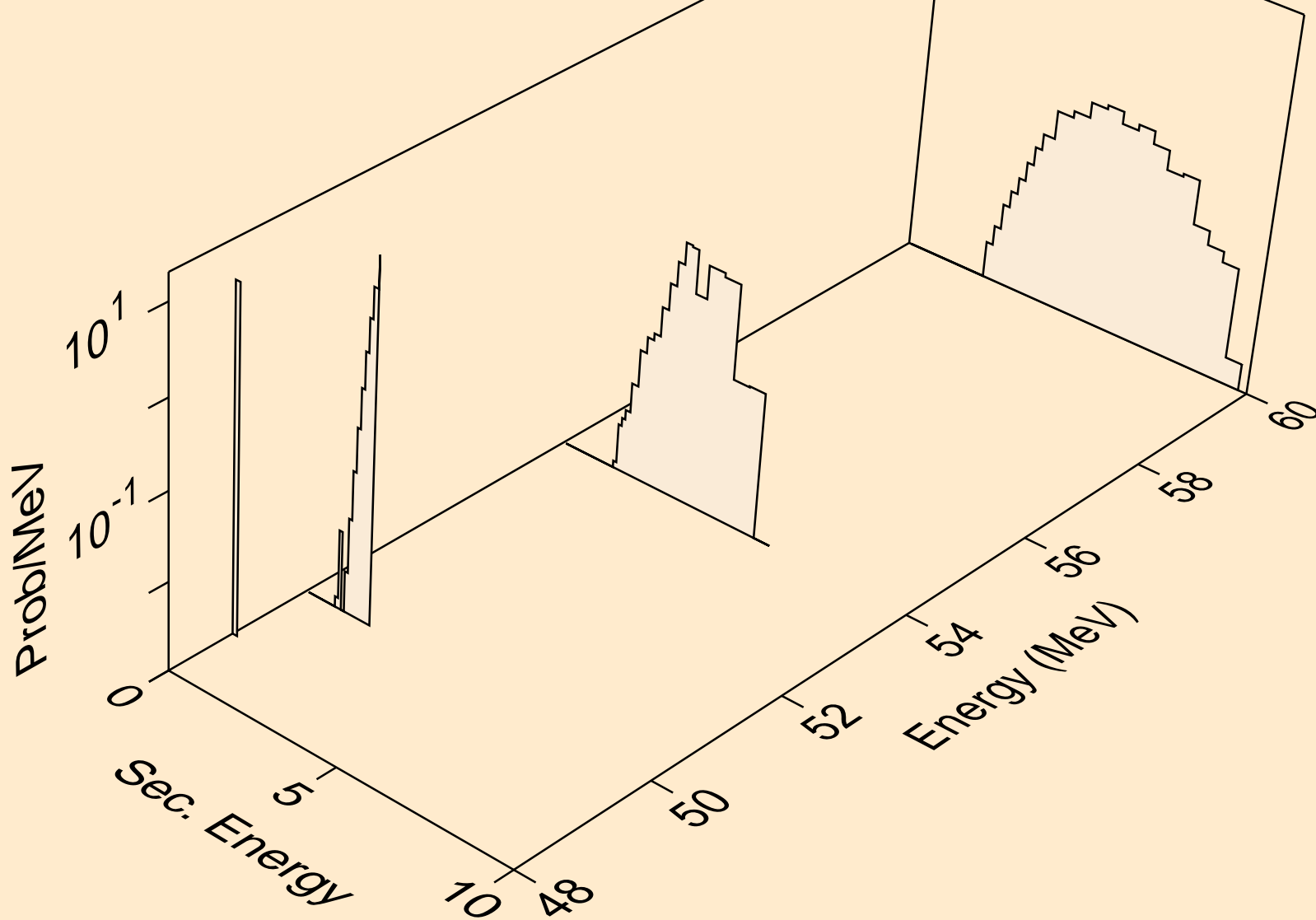

16-S-34 FOR FENDL-3.1 FROM TENDL-2010 WITH NJOY2012.50+
he3s from (n,nphe3)

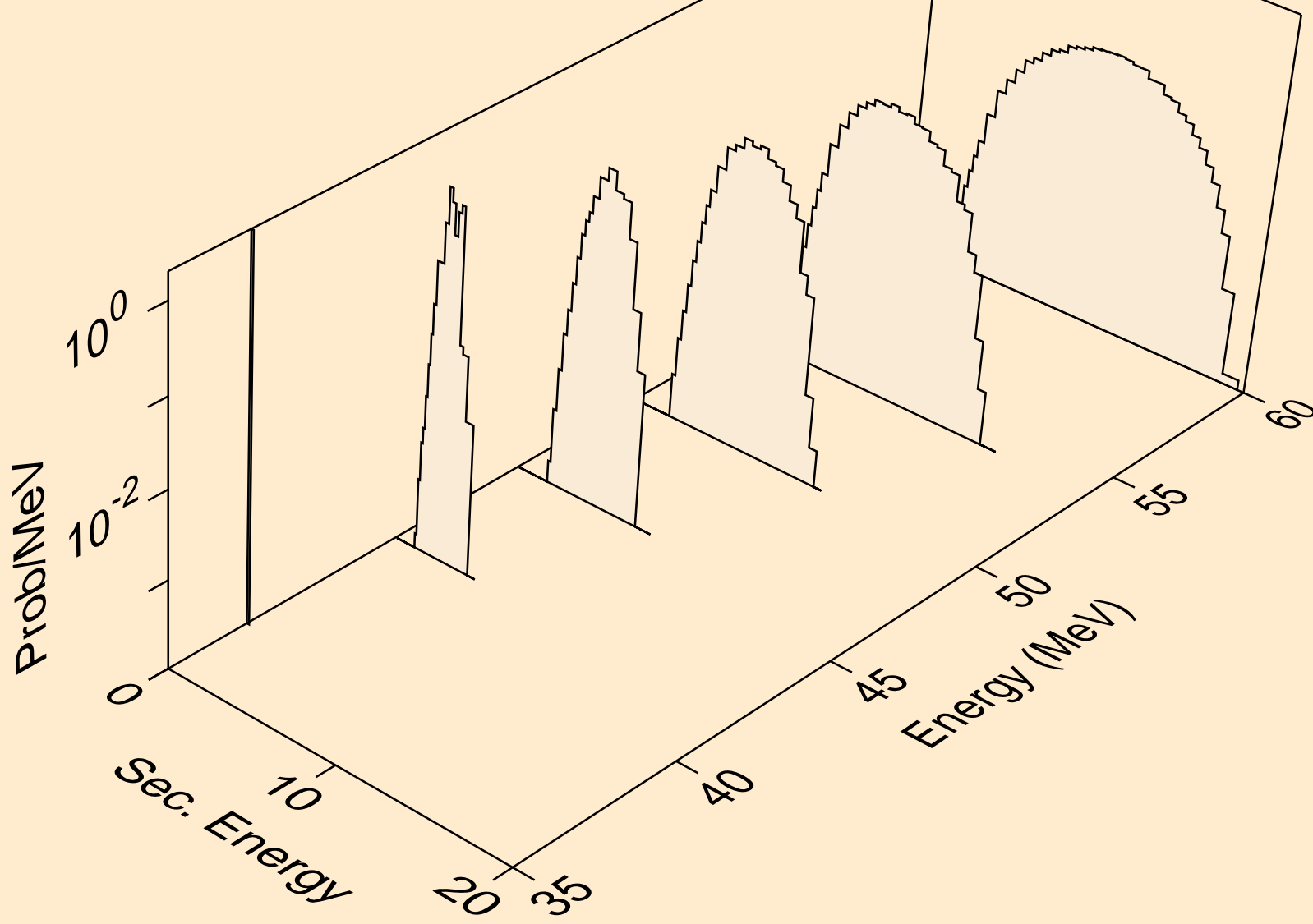

16-S-34 FOR FENDL-3.1 FROM TENDL-2010 WITH NJOY2012.50+
he3s from (n,ndhe3)

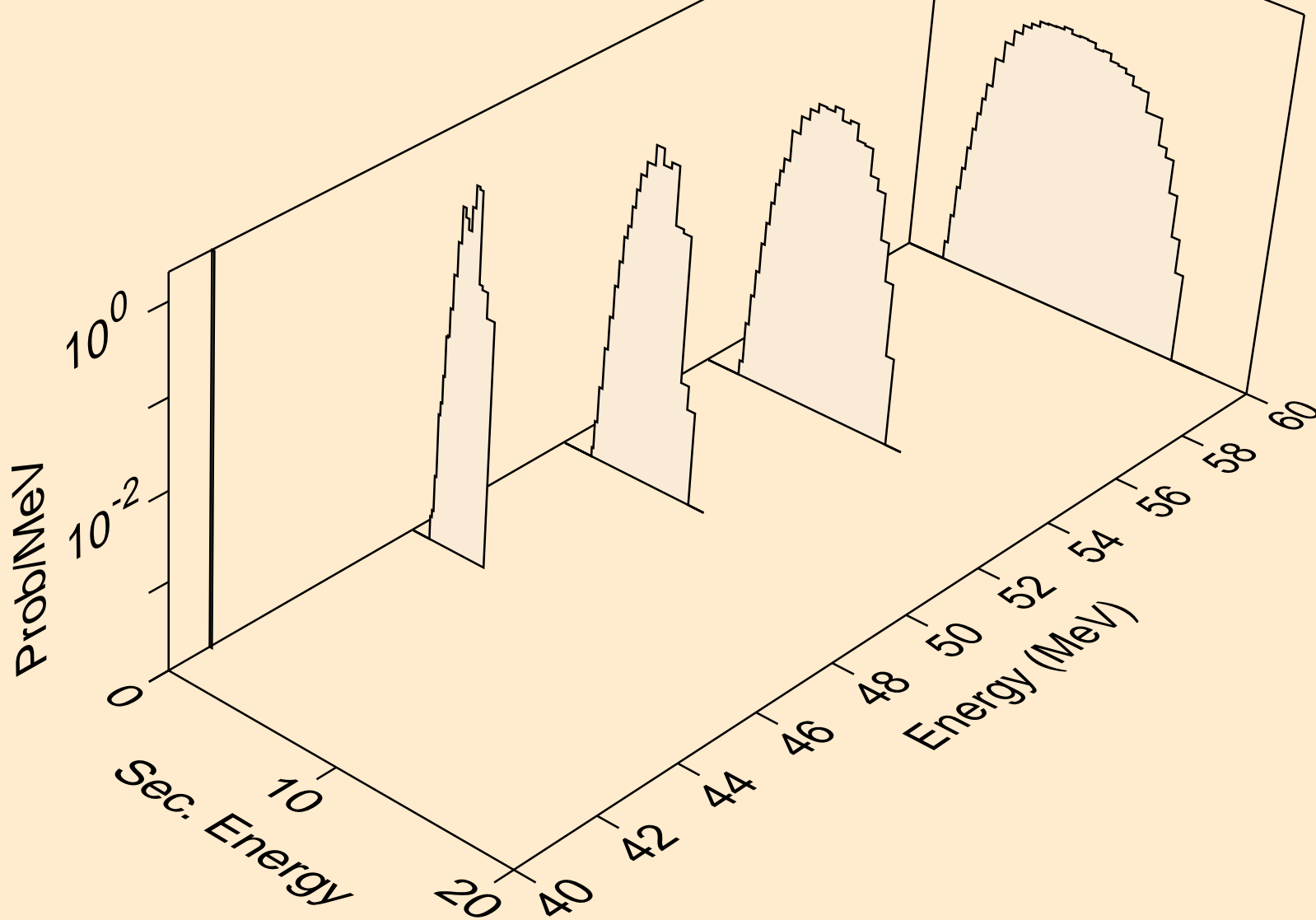

16-S-34 FOR FENDL-3.1 FROM TENDL-2010 WITH NJOY2012.50+
he3s from (n,nthe3)

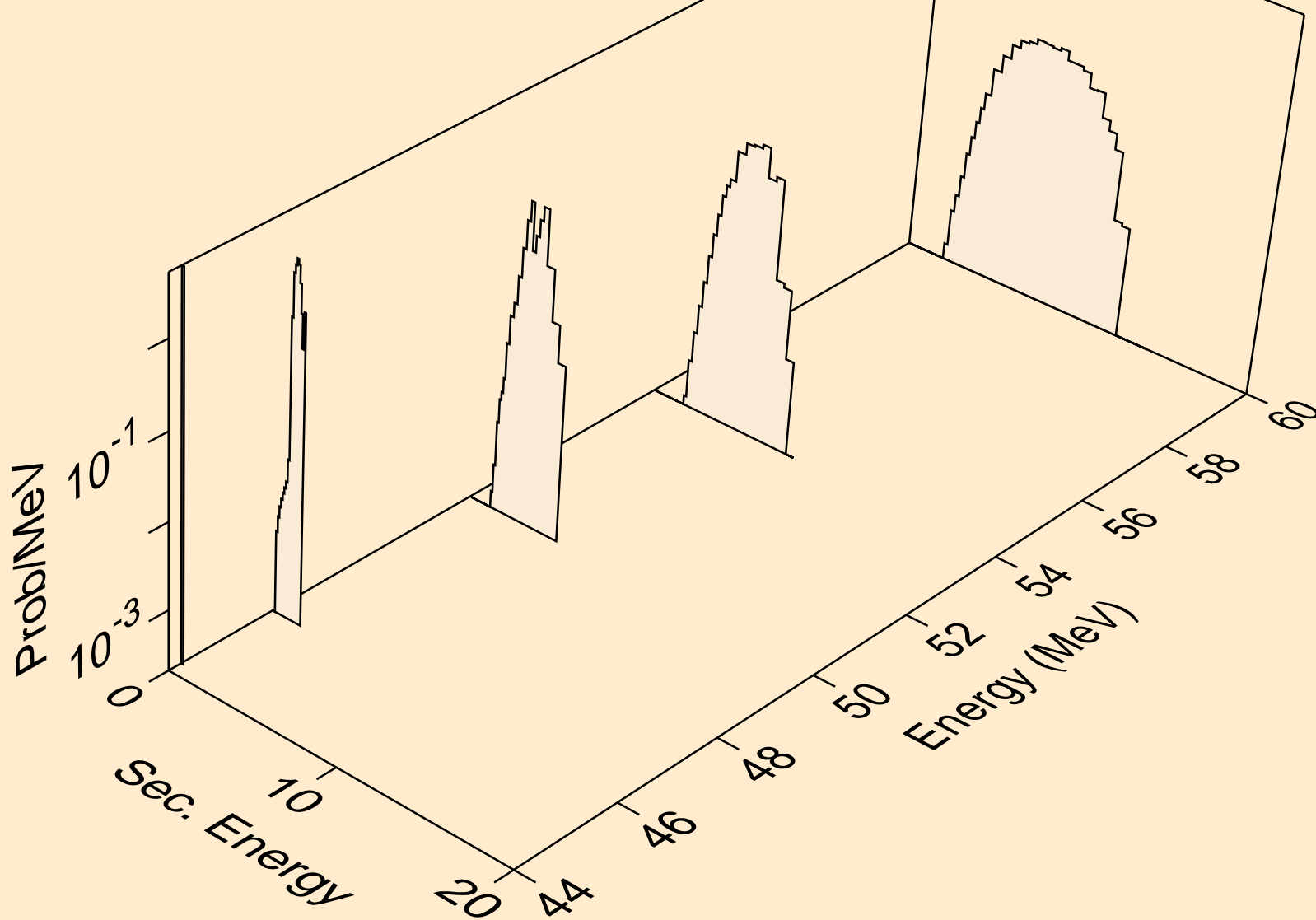

16-S-34 FOR FENDL-3.1 FROM TENDL-2010 WITH NJOY2012.50+
he3s from (n,phe3)

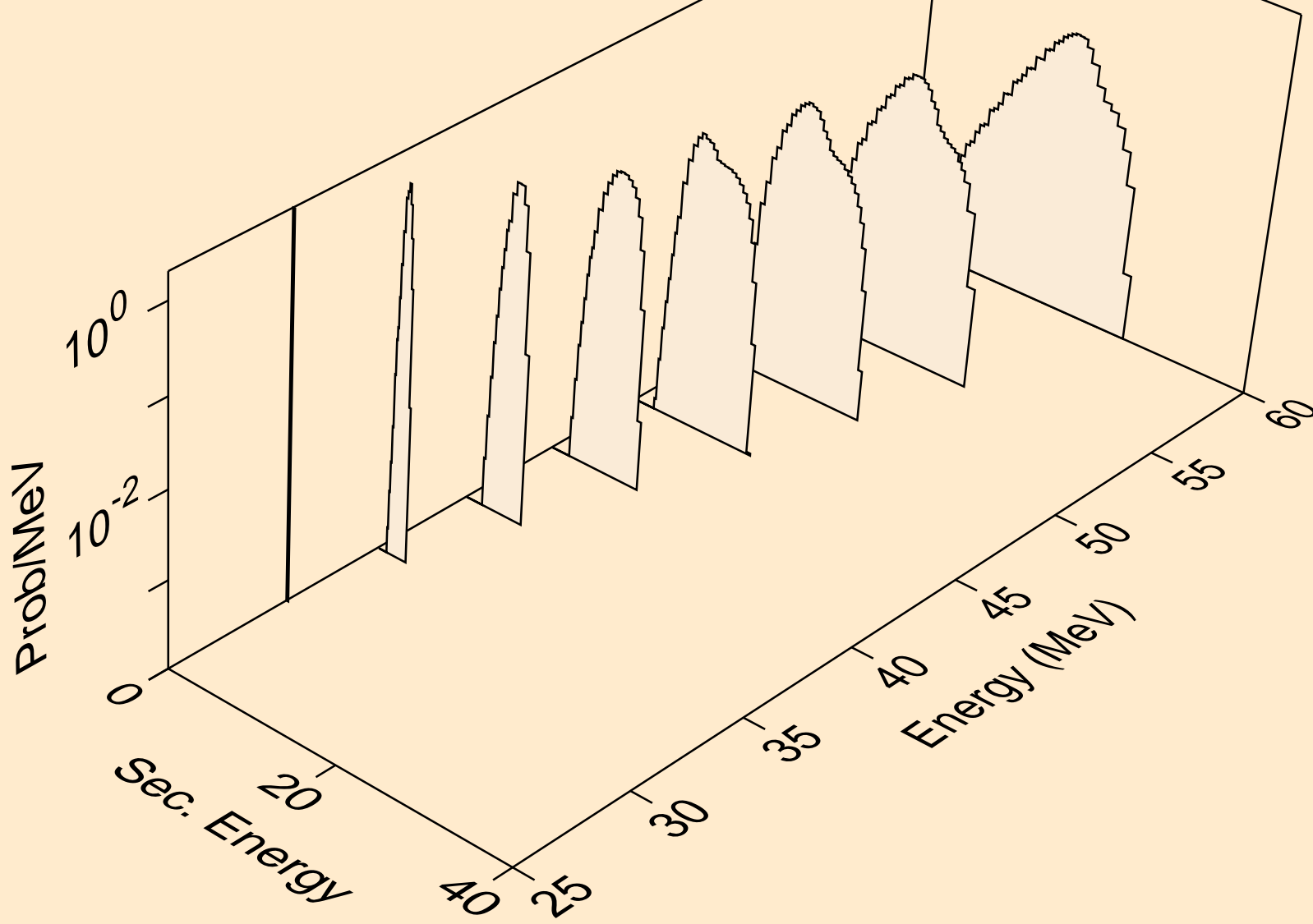

16-S-34 FOR FENDL-3.1 FROM TENDL-2010 WITH NJOY2012.50+
he3s from (n,d)he3)

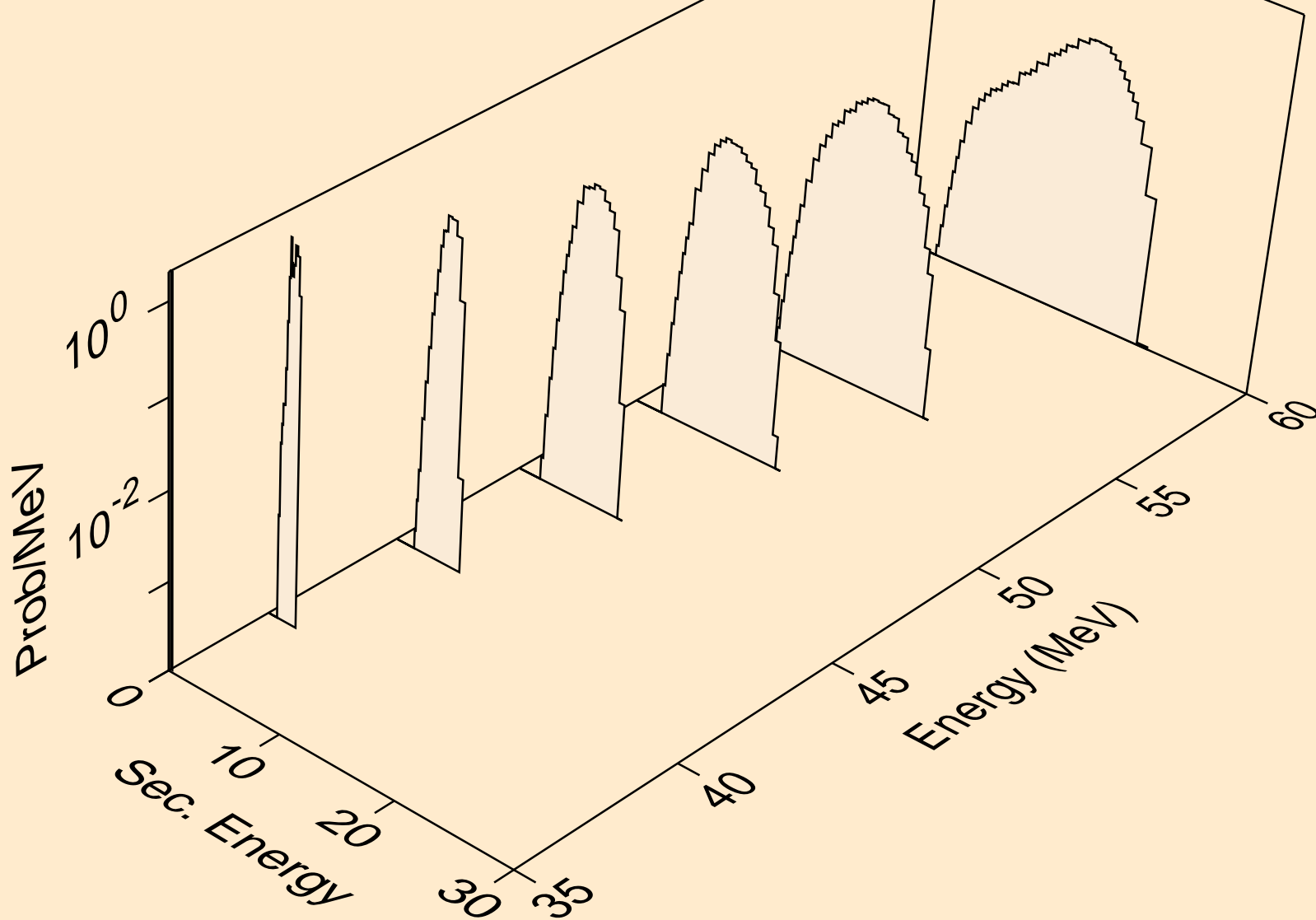

16-S-34 FOR FENDL-3.1 FROM TENDL-2010 WITH NJOY2012.50+
he3s from (n,he3a)

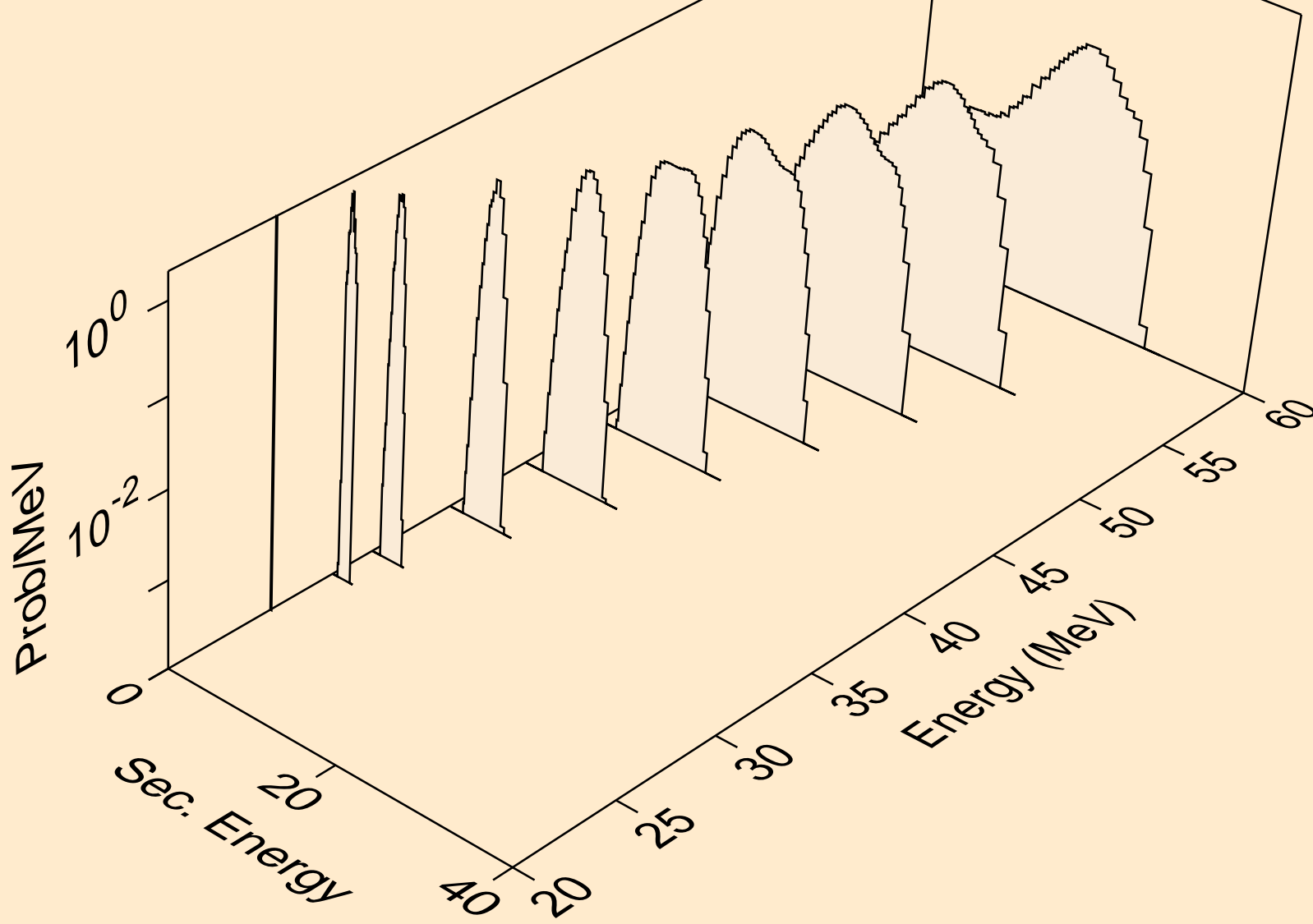

16-S-34 FOR FENDL-3.1 FROM TENDL-2010 WITH NJOY2012.50+
alphas from (n,x)

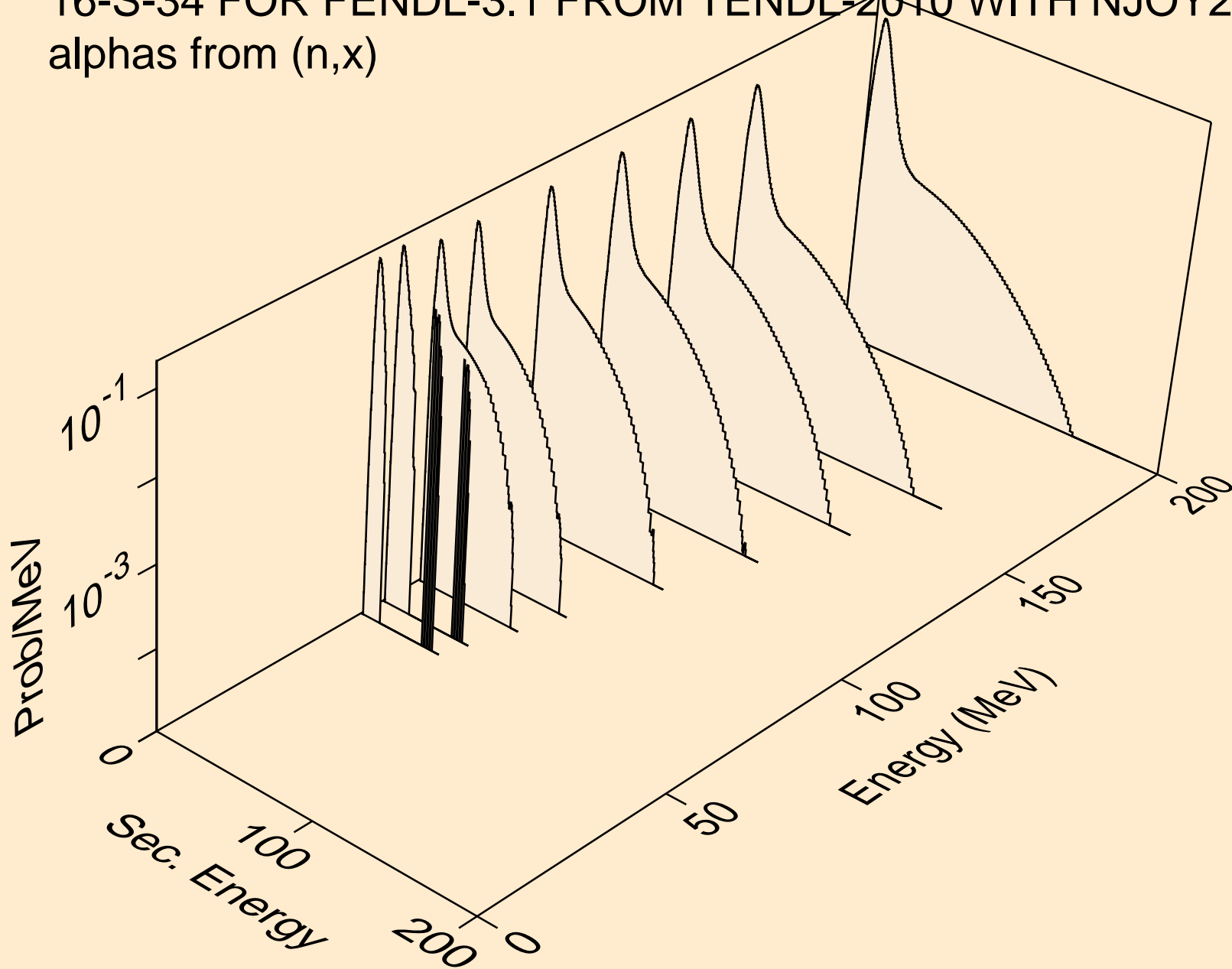

16-S-34 FOR FENDL-3.1 FROM TENDL-2010 WITH NJOY2012.50+
alphas from (n,n*)a

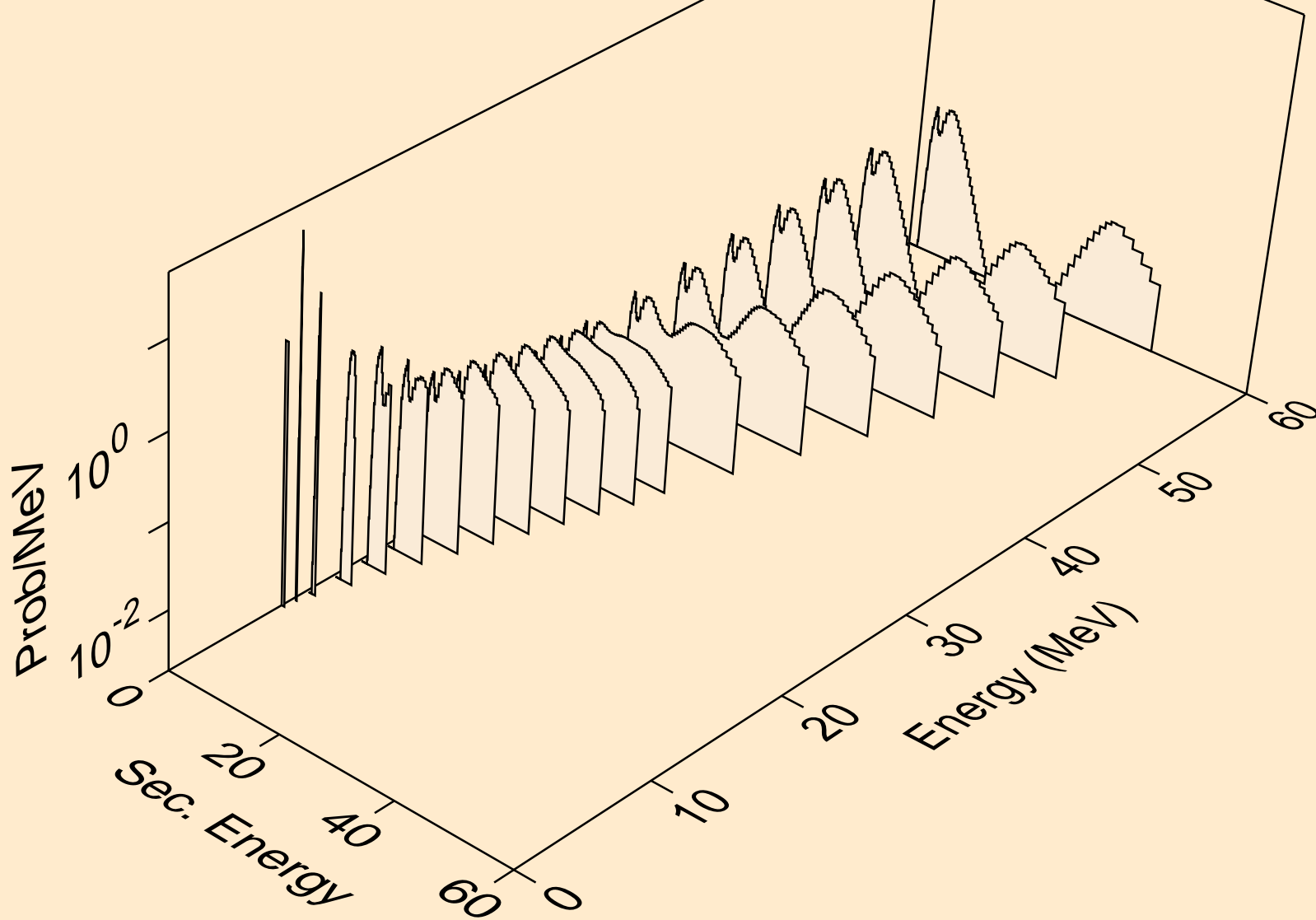

16-S-34 FOR FENDL-3.1 FROM TENDL-2010 WITH NJOY2012.50+
alphas from (n,n*)3a

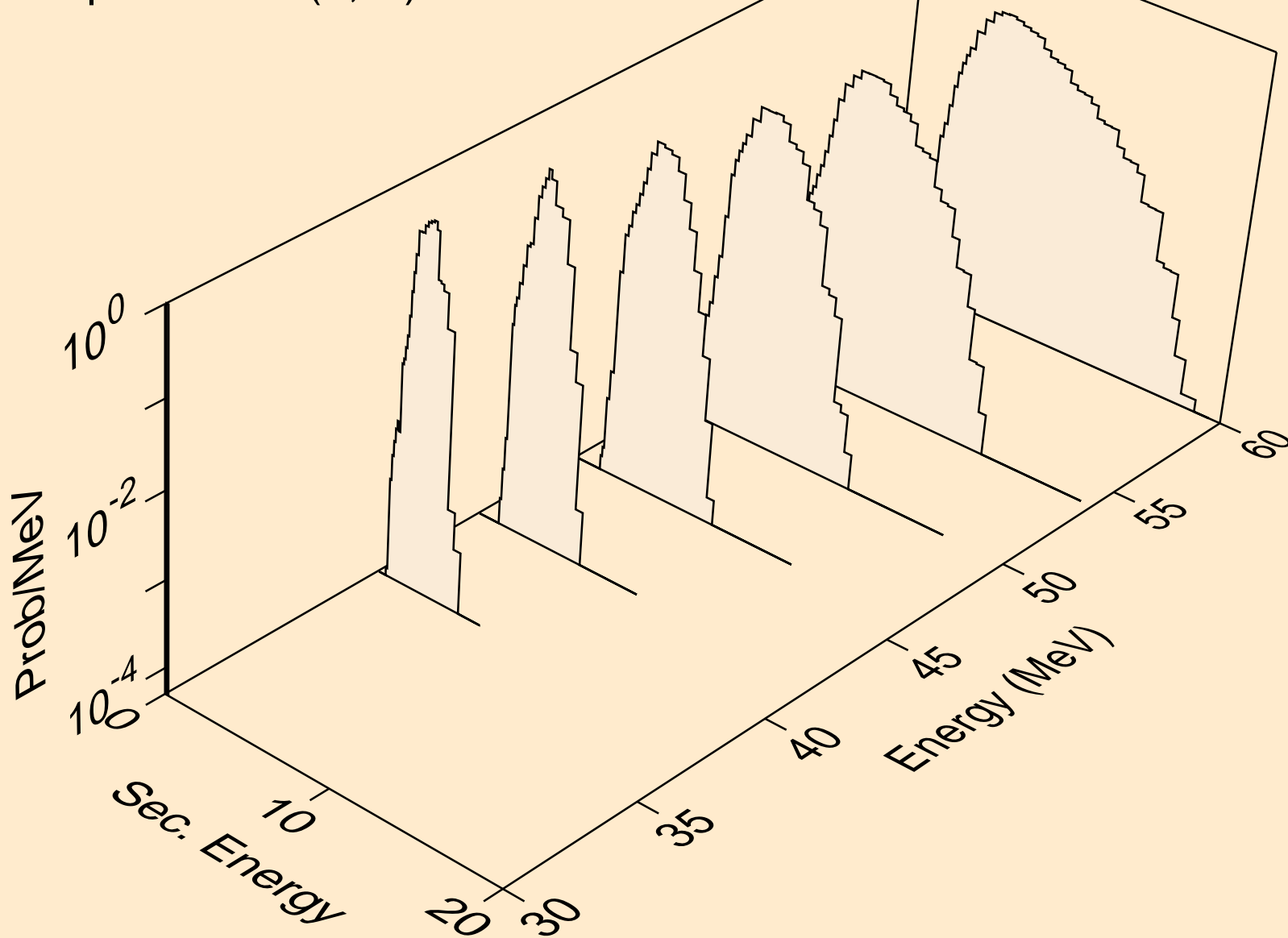

16-S-34 FOR FENDL-3.1 FROM TENDL-2010 WITH NJOY2012.50+
alphas from (n,2n)a

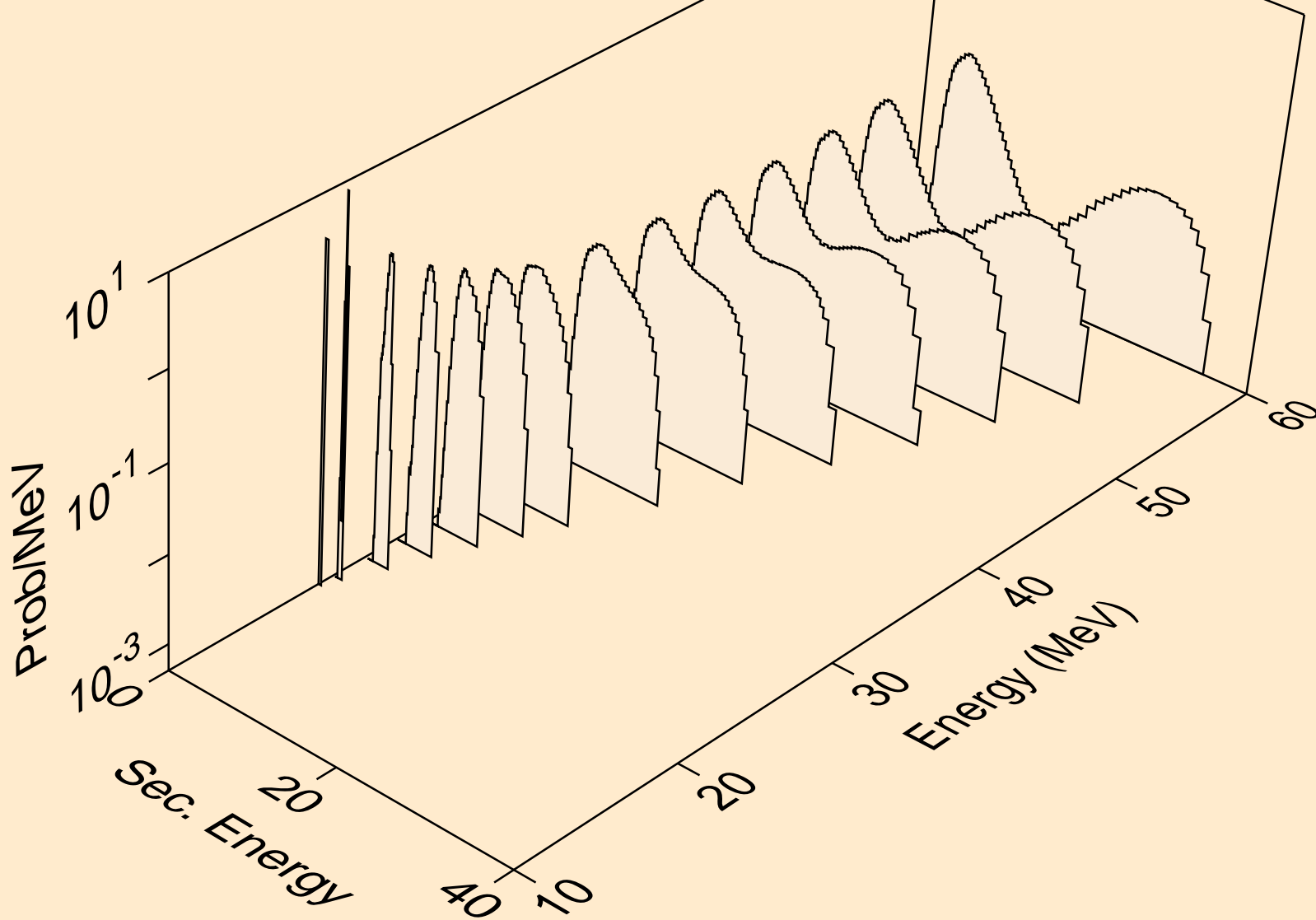

16-S-34 FOR FENDL-3.1 FROM TENDL-2010 WITH NJOY2012.50+
alphas from (n,3n)a

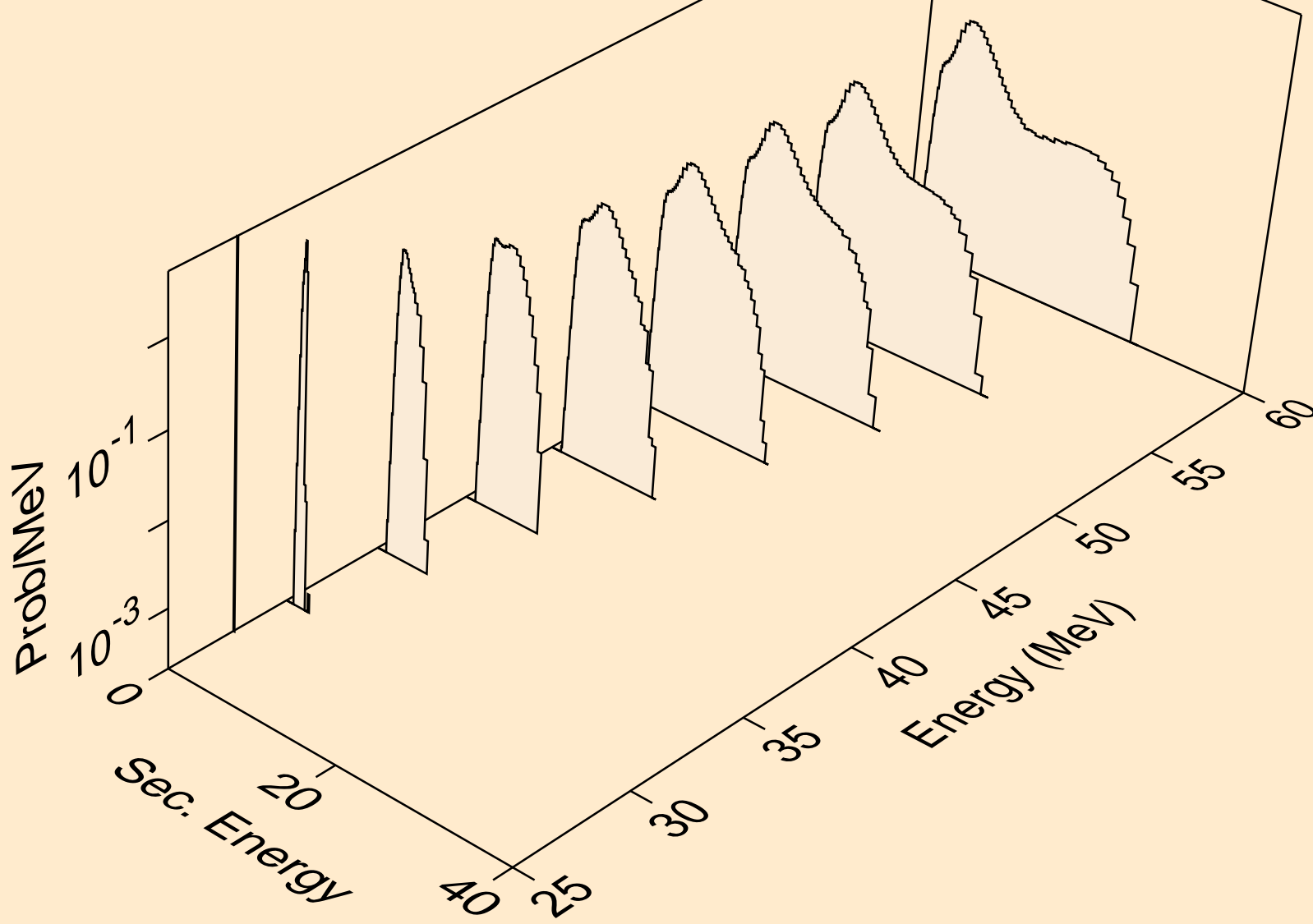

16-S-34 FOR FENDL-3.1 FROM TENDL-2010 WITH NJOY2012.50+
alphas from (n,n*)2a

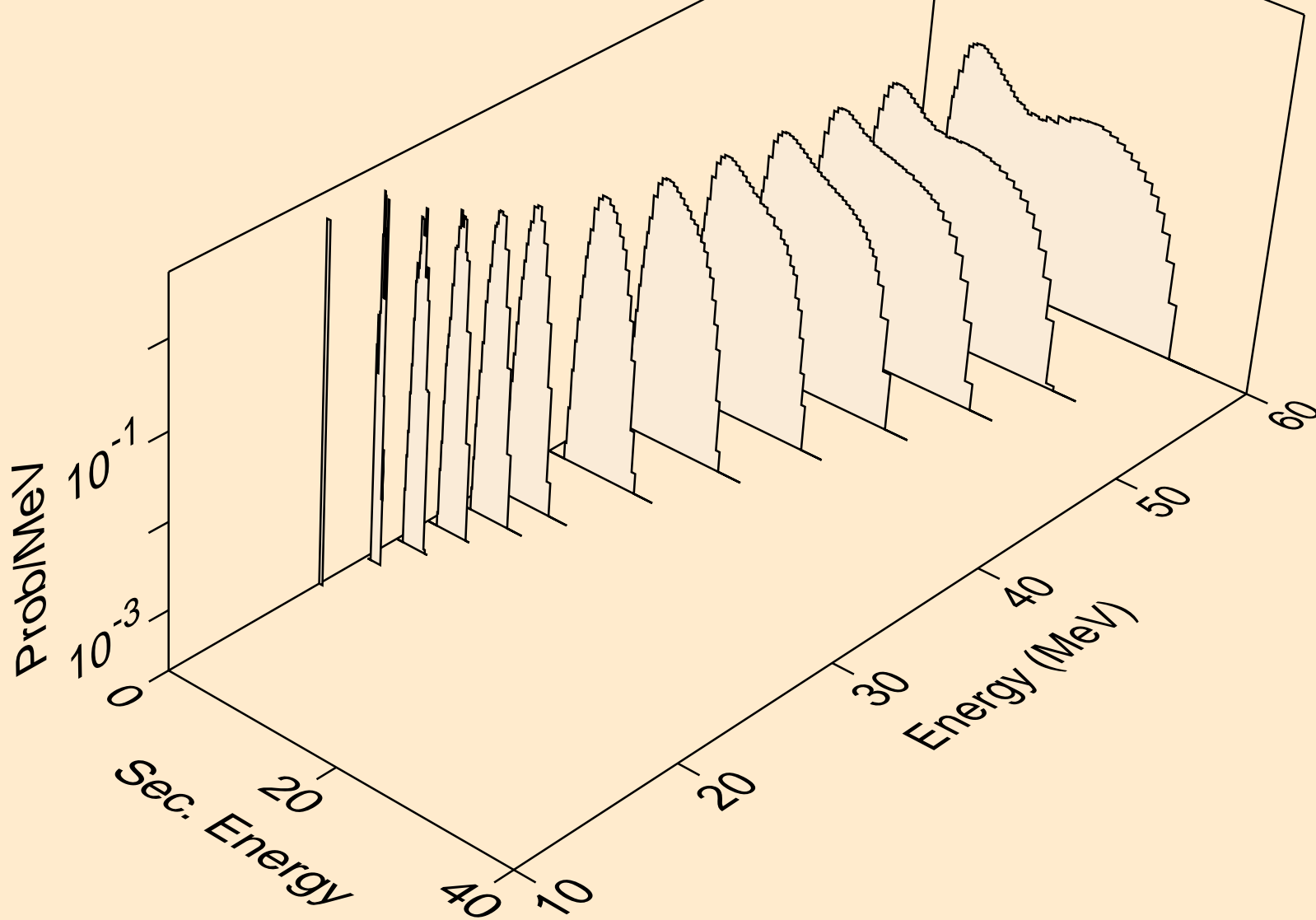

16-S-34 FOR FENDL-3.1 FROM TENDL-2010 WITH NJOY2012.50+
alphas from (n,2n)2a

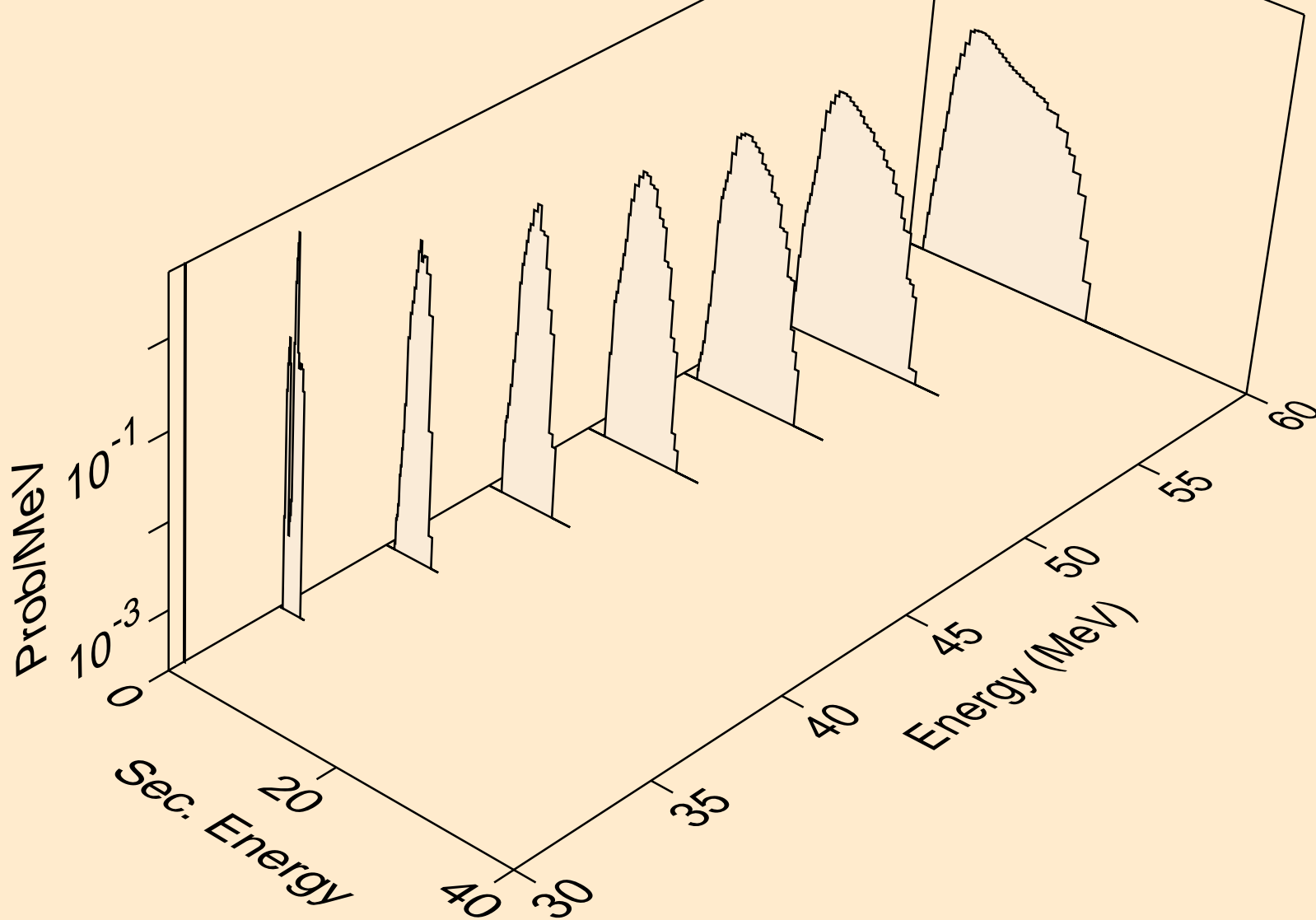

16-S-34 FOR FENDL-3.1 FROM TENDL-2010 WITH NJOY2012.50+
alphas from (n,n*)d2a

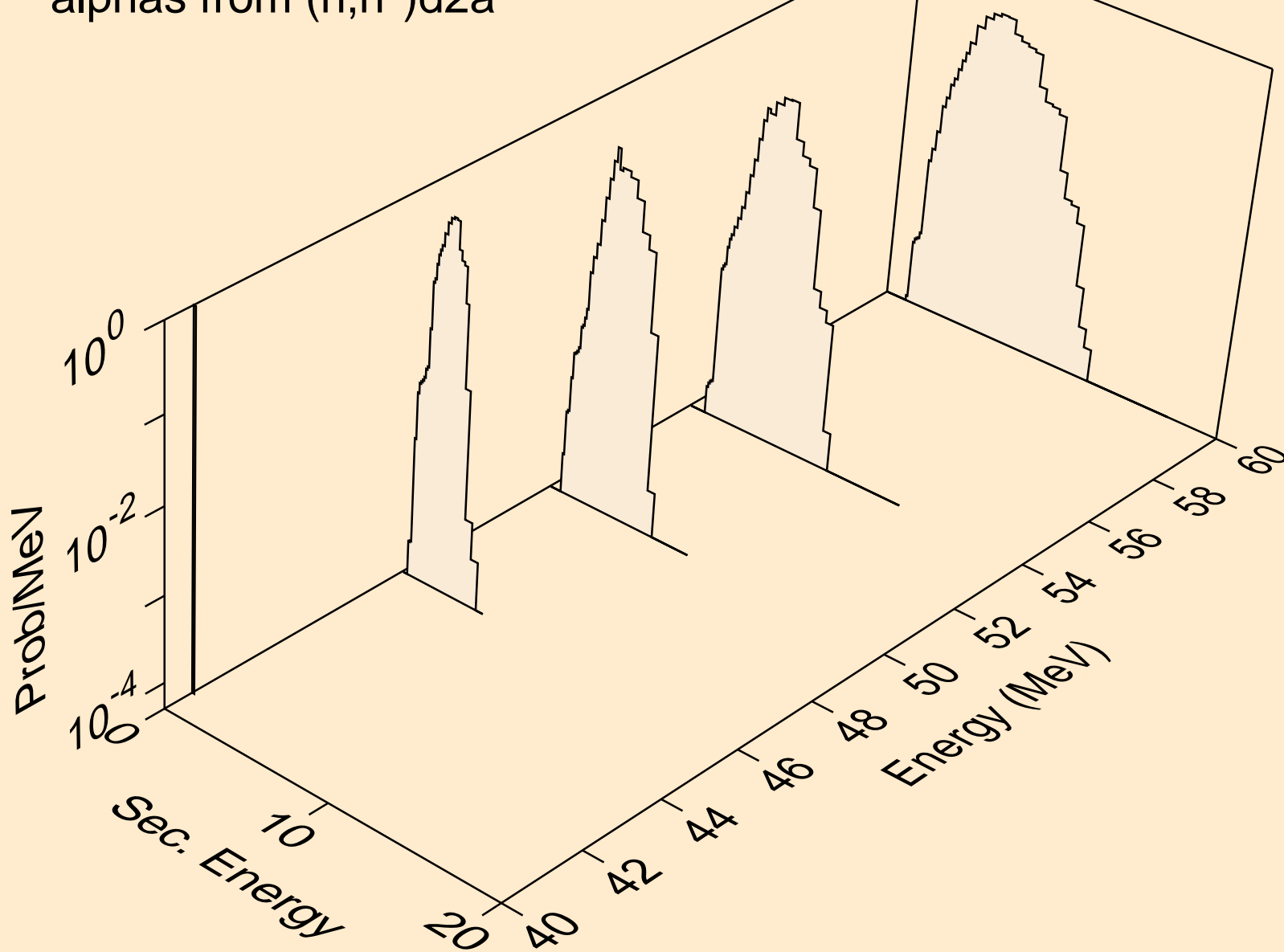

16-S-34 FOR FENDL-3.1 FROM TENDL-2010 WITH NJOY2012.50+
alphas from (n,n*)t2a

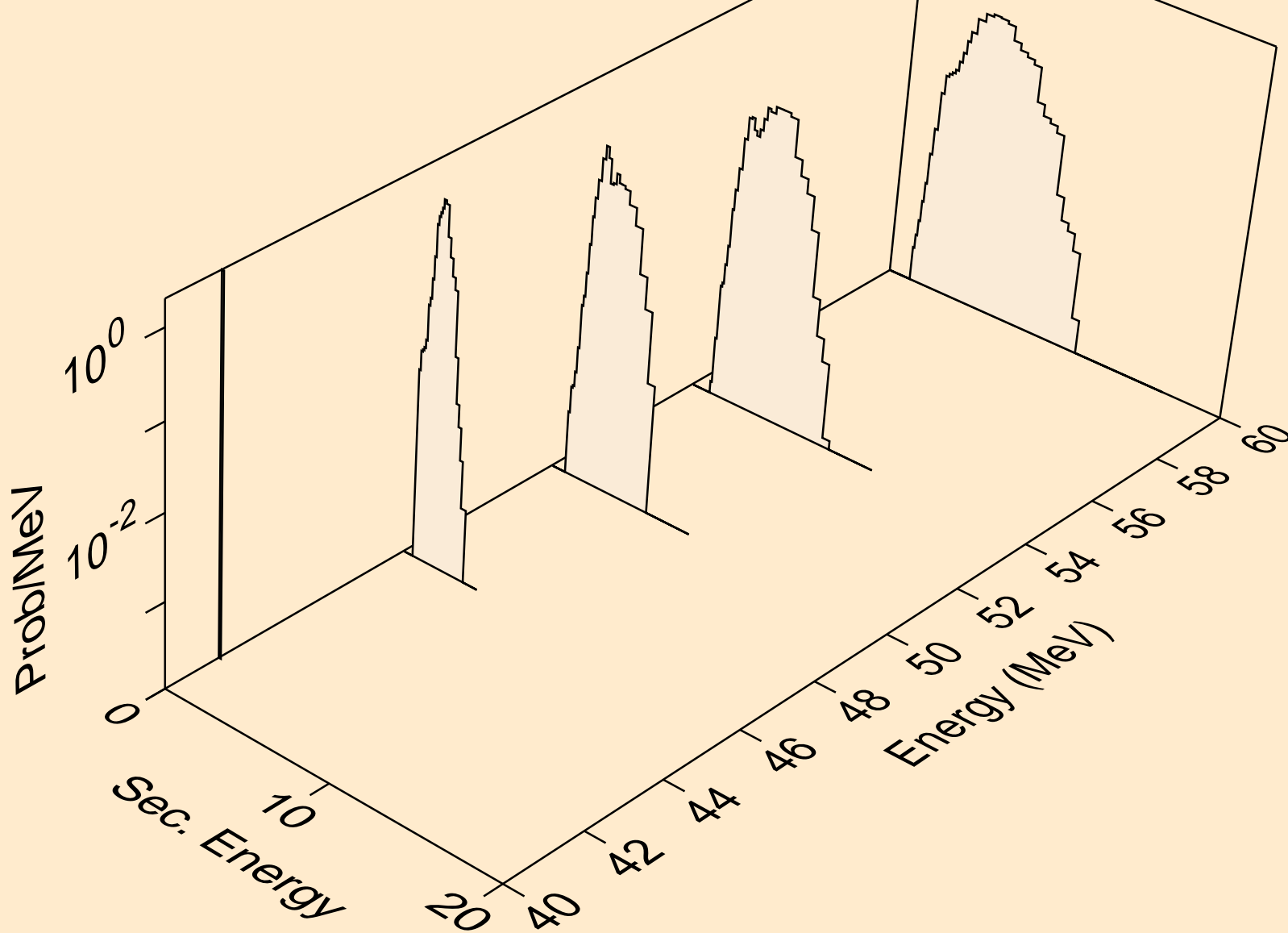

16-S-34 FOR FENDL-3.1 FROM TENDL-2010 WITH NJOY2012.50+
alphas from (n,npa)

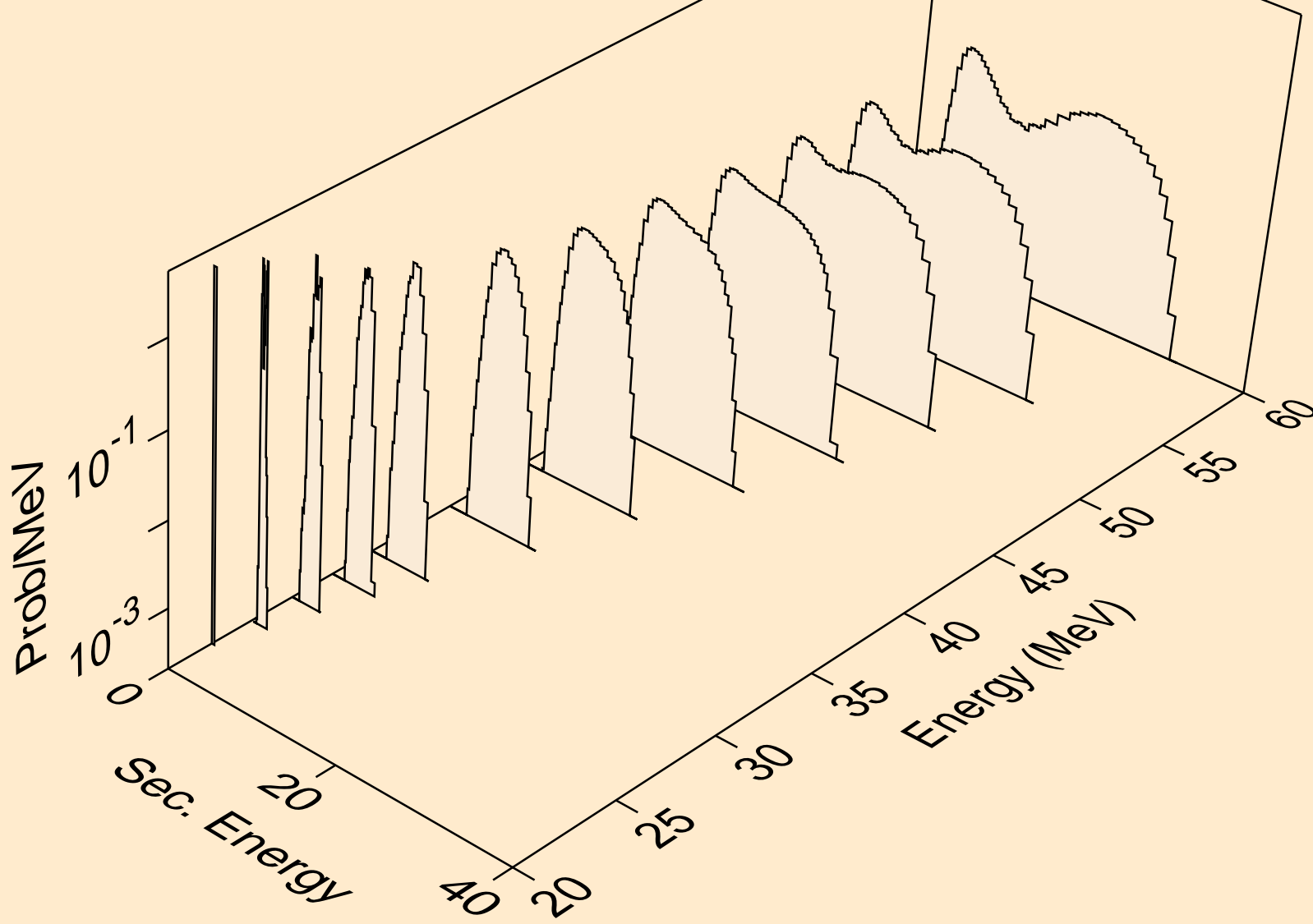

16-S-34 FOR FENDL-3.1 FROM TENDL-2010 WITH NJOY2012.50+
alphas from (n,a)

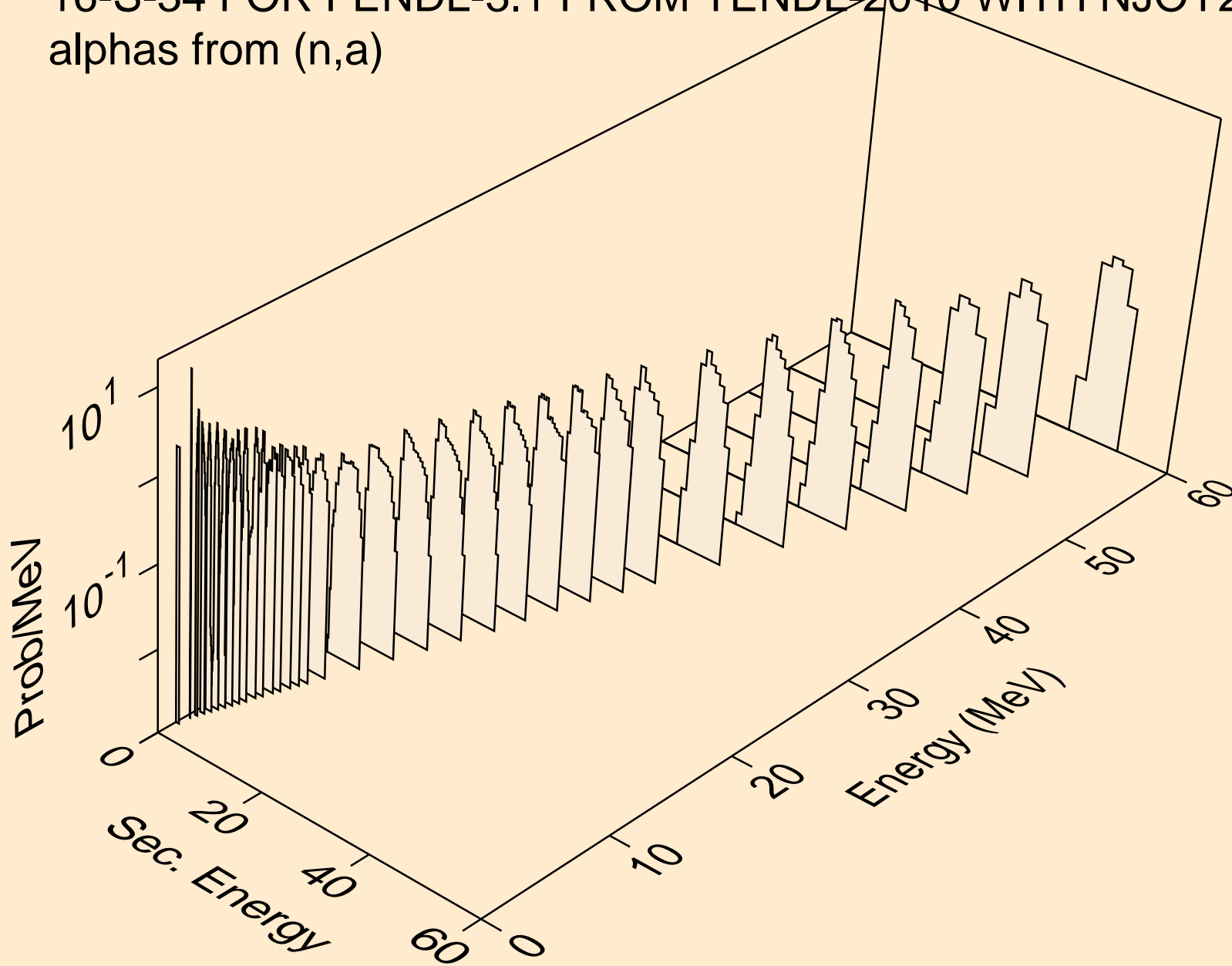

16-S-34 FOR FENDL-3.1 FROM TENDL-2010 WITH NJOY2012.50+
alphas from (n,2a)

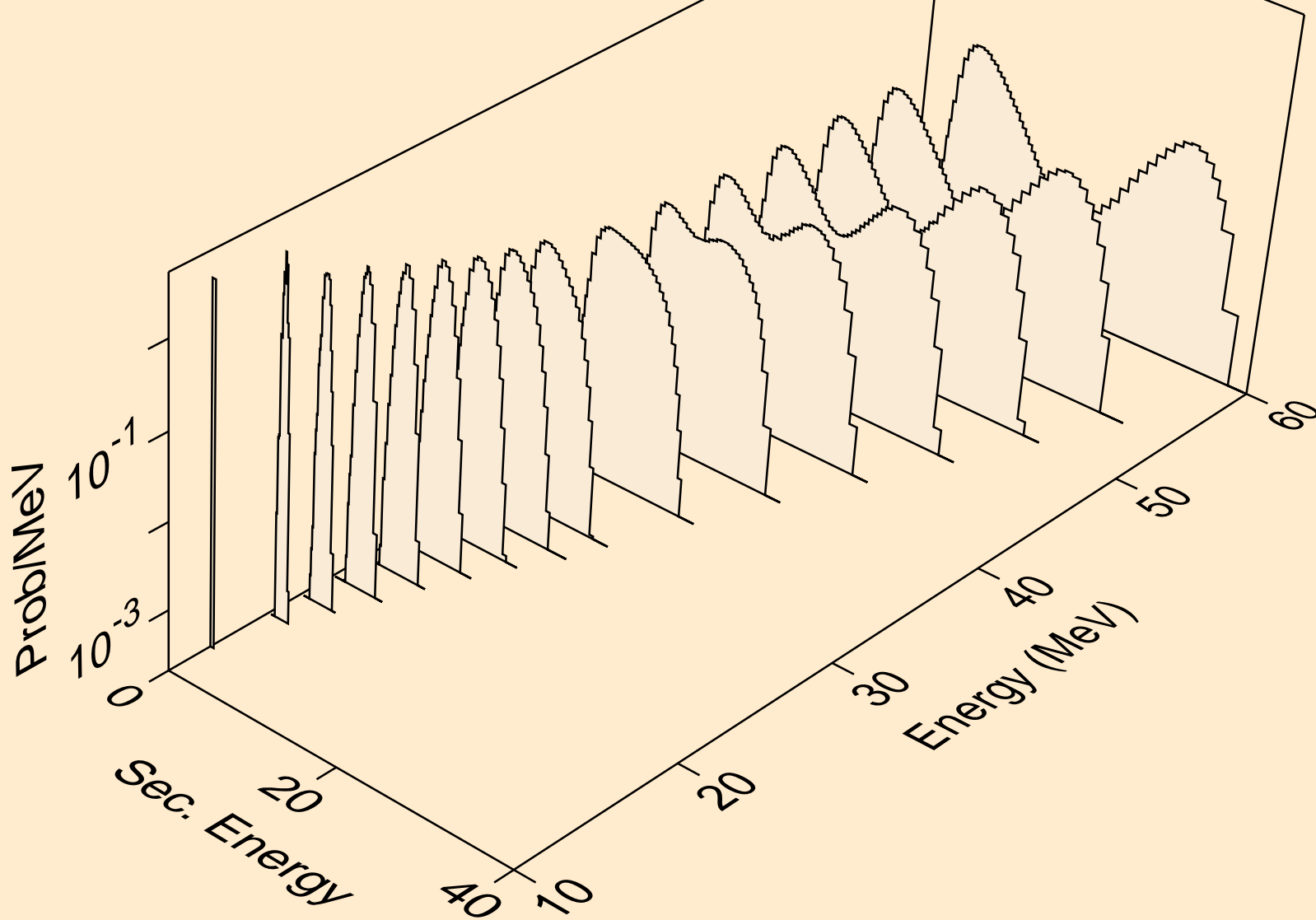

16-S-34 FOR FENDL-3.1 FROM TENDL-2010 WITH NJOY2012.50+
alphas from (n,3a)

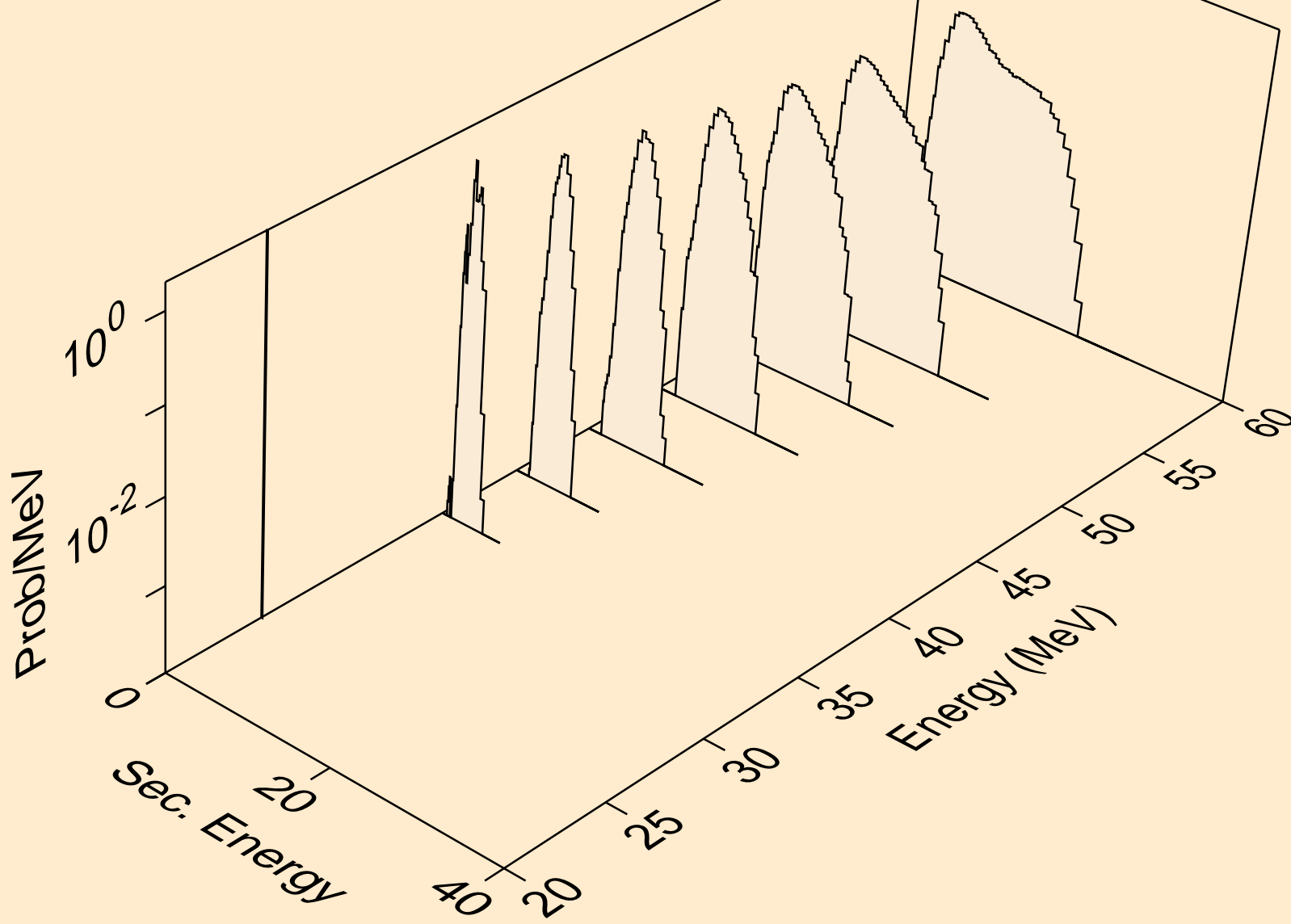

16-S-34 FOR FENDL-3.1 FROM TENDL-2010 WITH NJOY2012.50+
alphas from (n,pa)

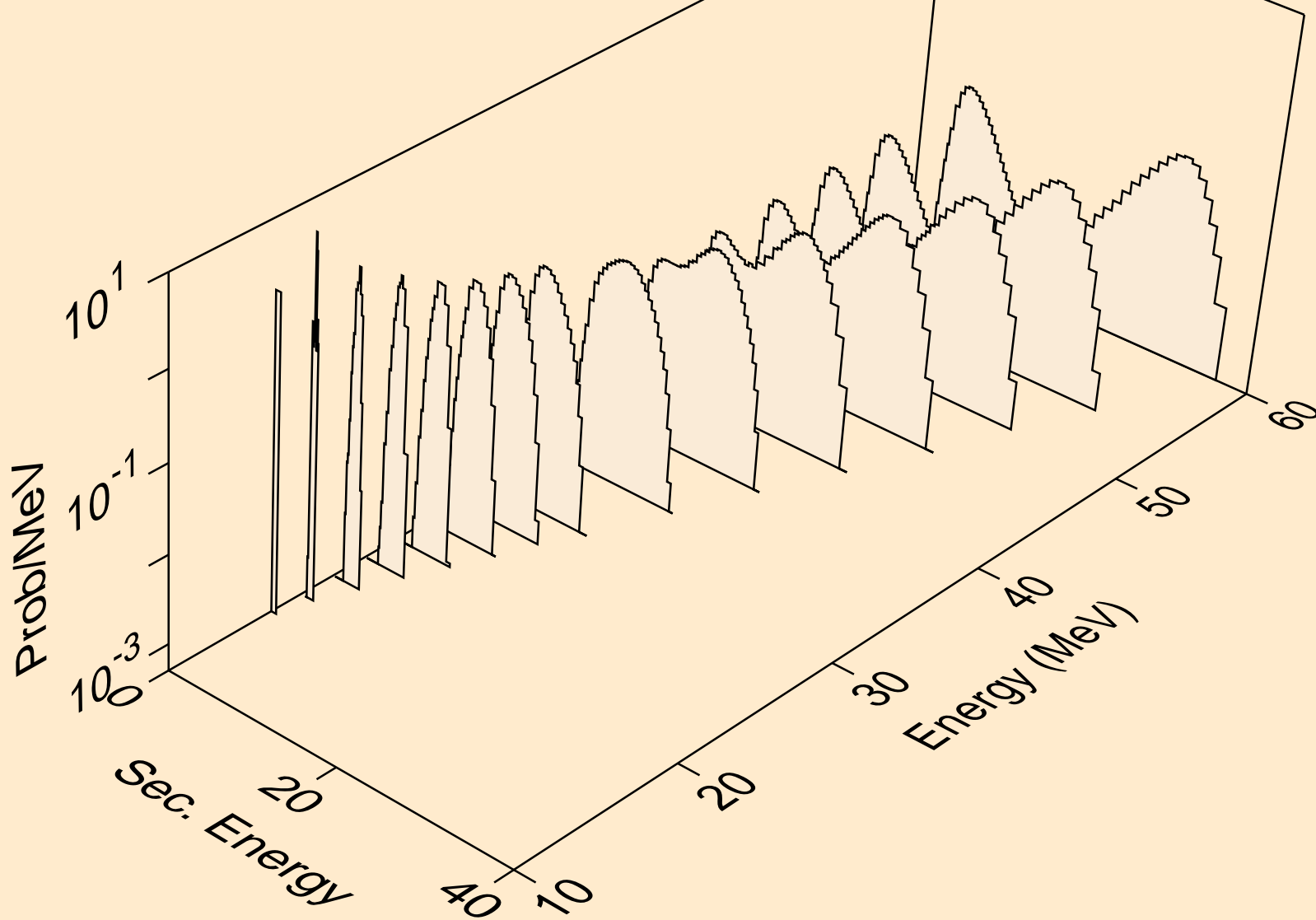

16-S-34 FOR FENDL-3.1 FROM TENDL-2010 WITH NJOY2012.50+
alphas from (n,t2a)

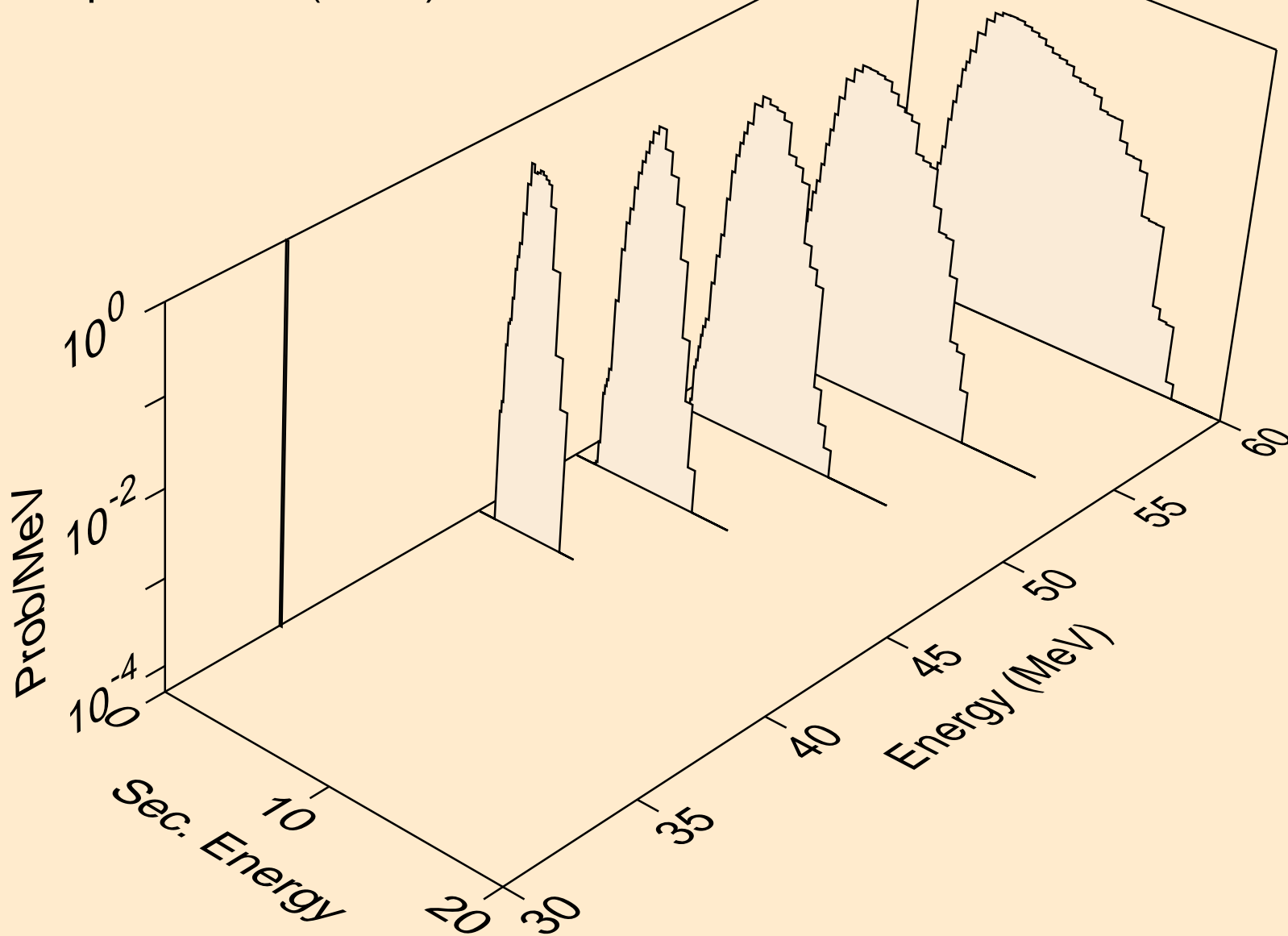

16-S-34 FOR FENDL-3.1 FROM TENDL-2010 WITH NJOY2012.50+
alphas from (n,d2a)

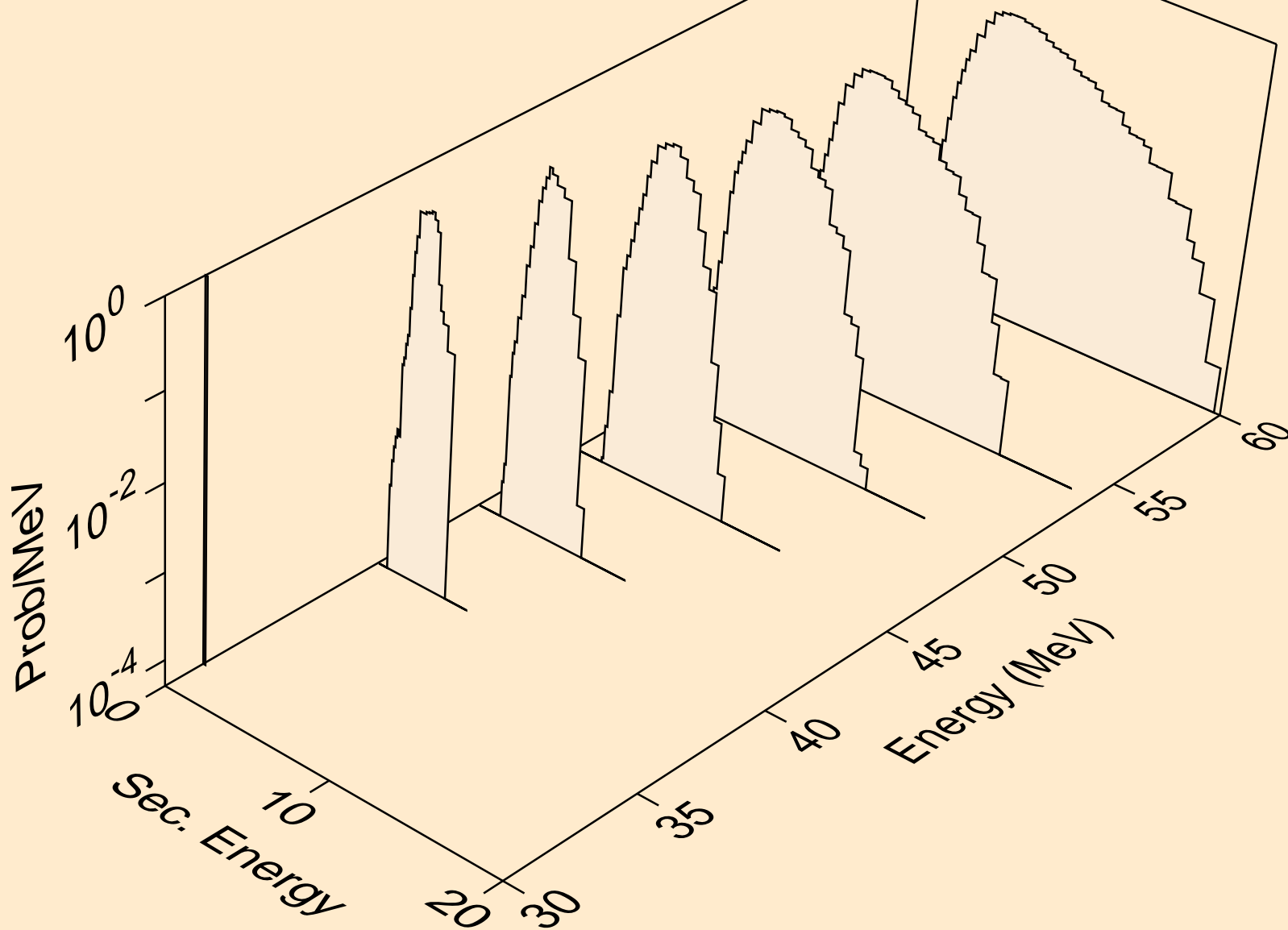

16-S-34 FOR FENDL-3.1 FROM TENDL-2010 WITH NJOY2012.50+
alphas from (n,da)

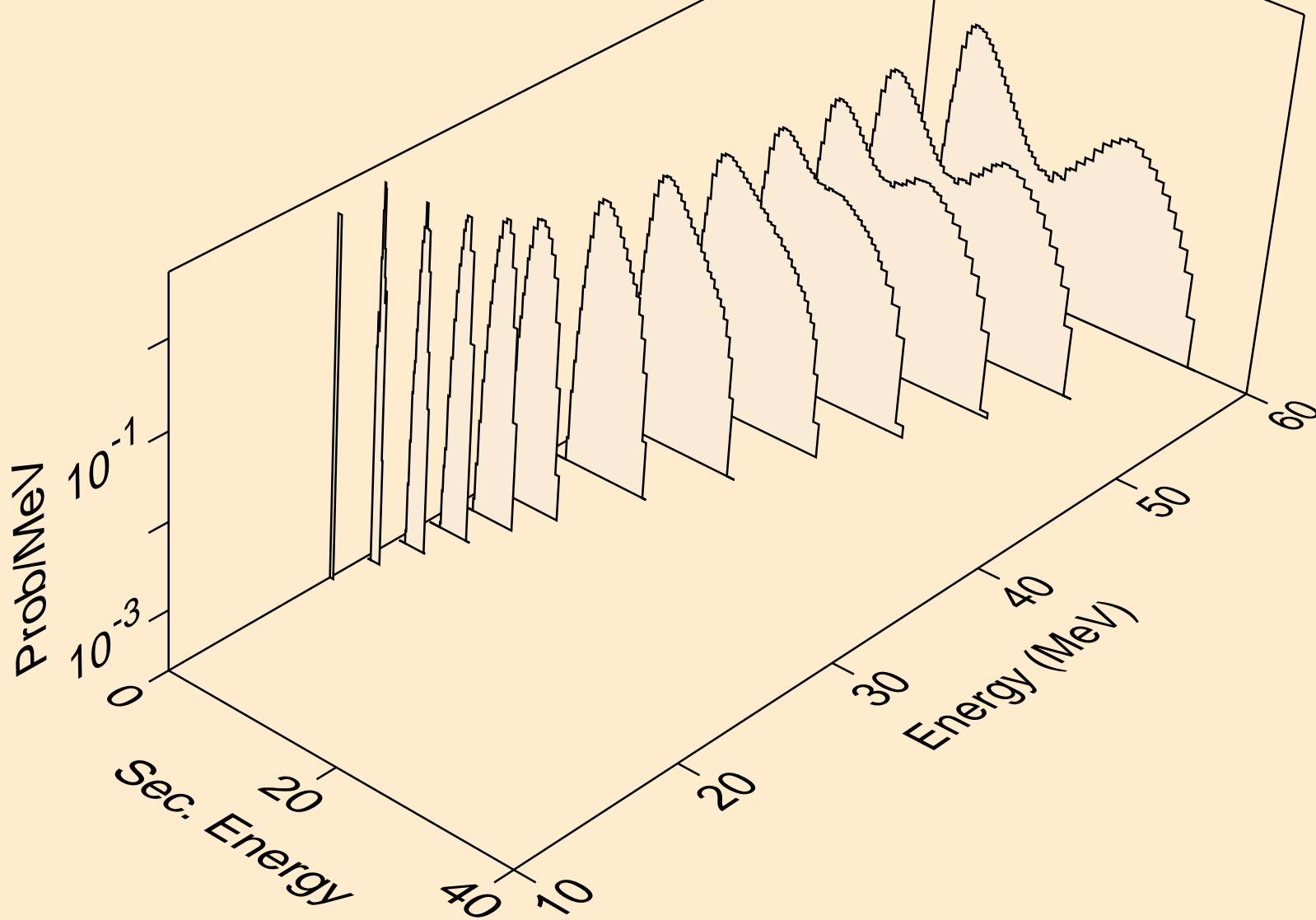

16-S-34 FOR FENDL-3.1 FROM TENDL-2010 WITH NJOY2012.50+
alphas from (n,ta)

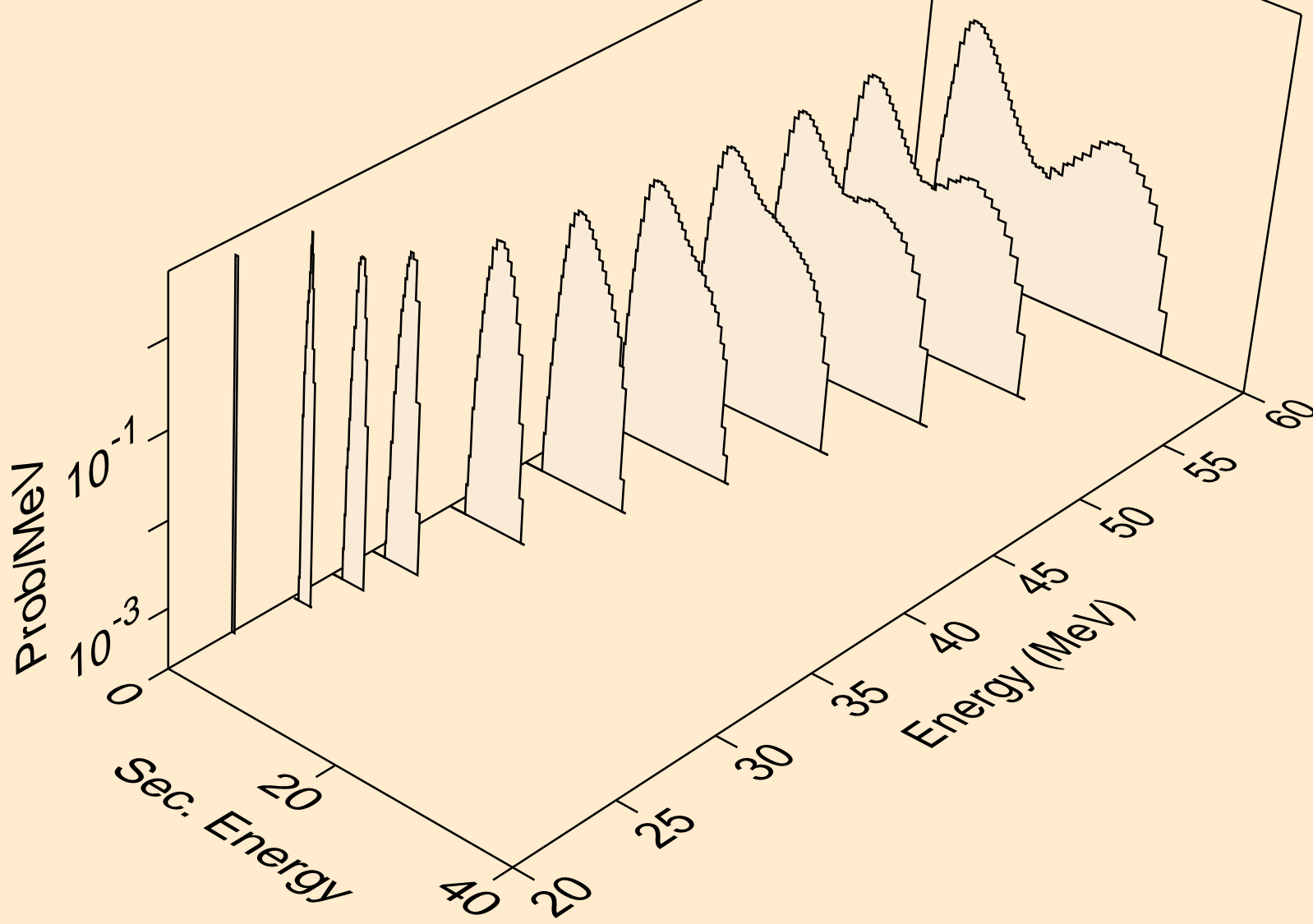

16-S-34 FOR FENDL-3.1 FROM TENDL-2010 WITH NJOY2012.50+
alphas from (n,nda)

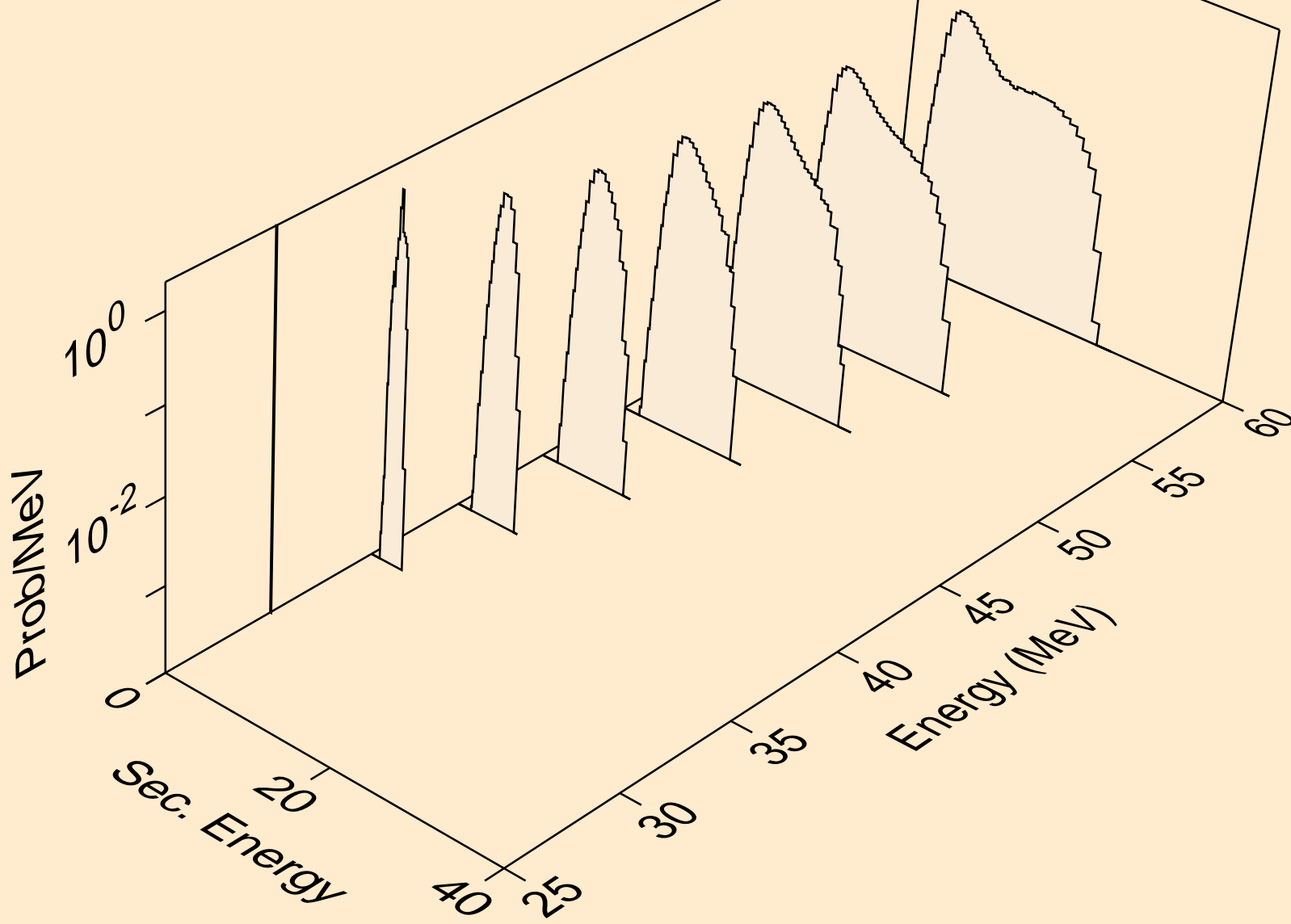

16-S-34 FOR FENDL-3.1 FROM TENDL-2010 WITH NJOY2012.50+
alphas from (n,2npa)

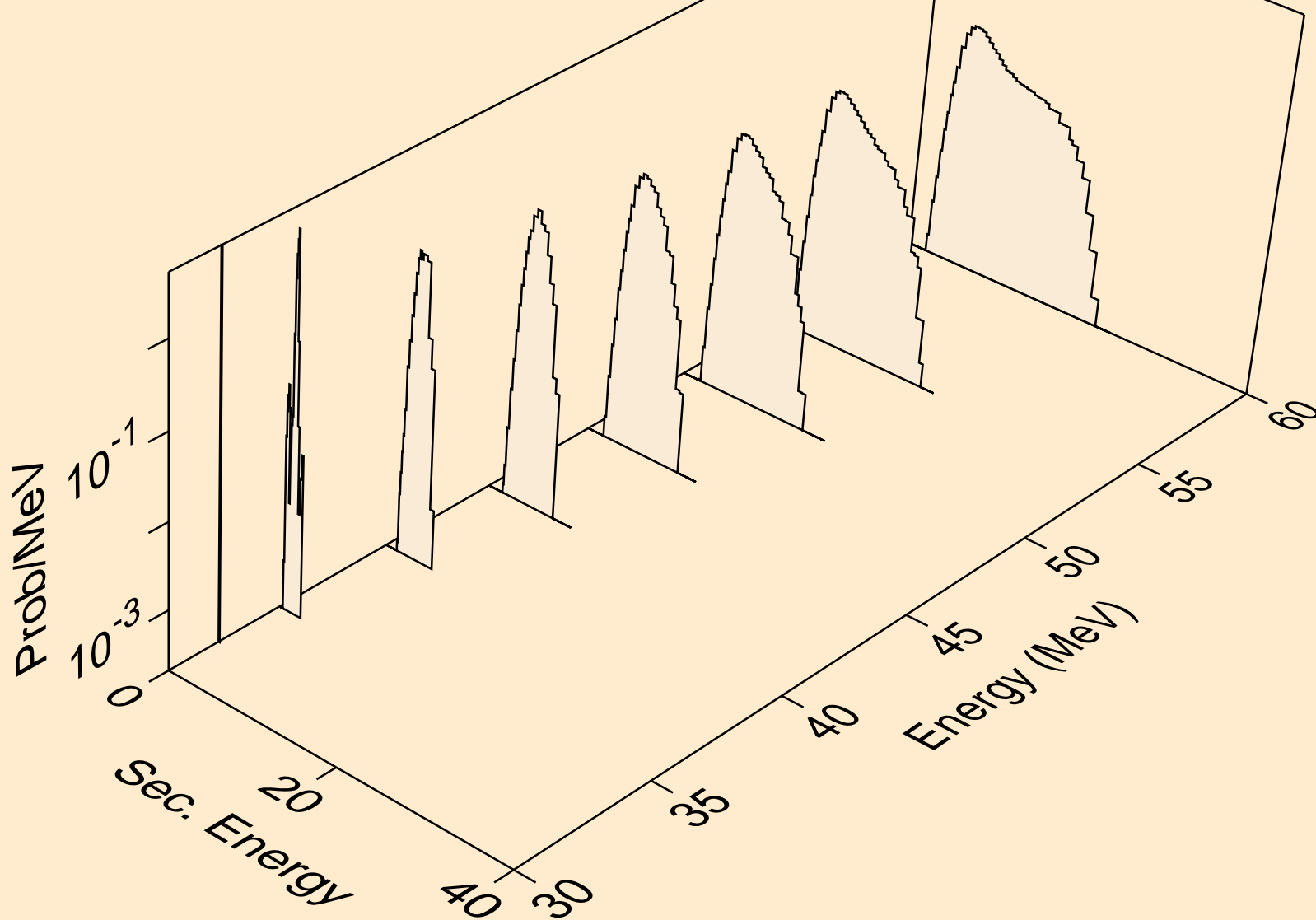

16-S-34 FOR FENDL-3.1 FROM TENDL-2010 WITH NJOY2012.50+
alphas from (n,4na)

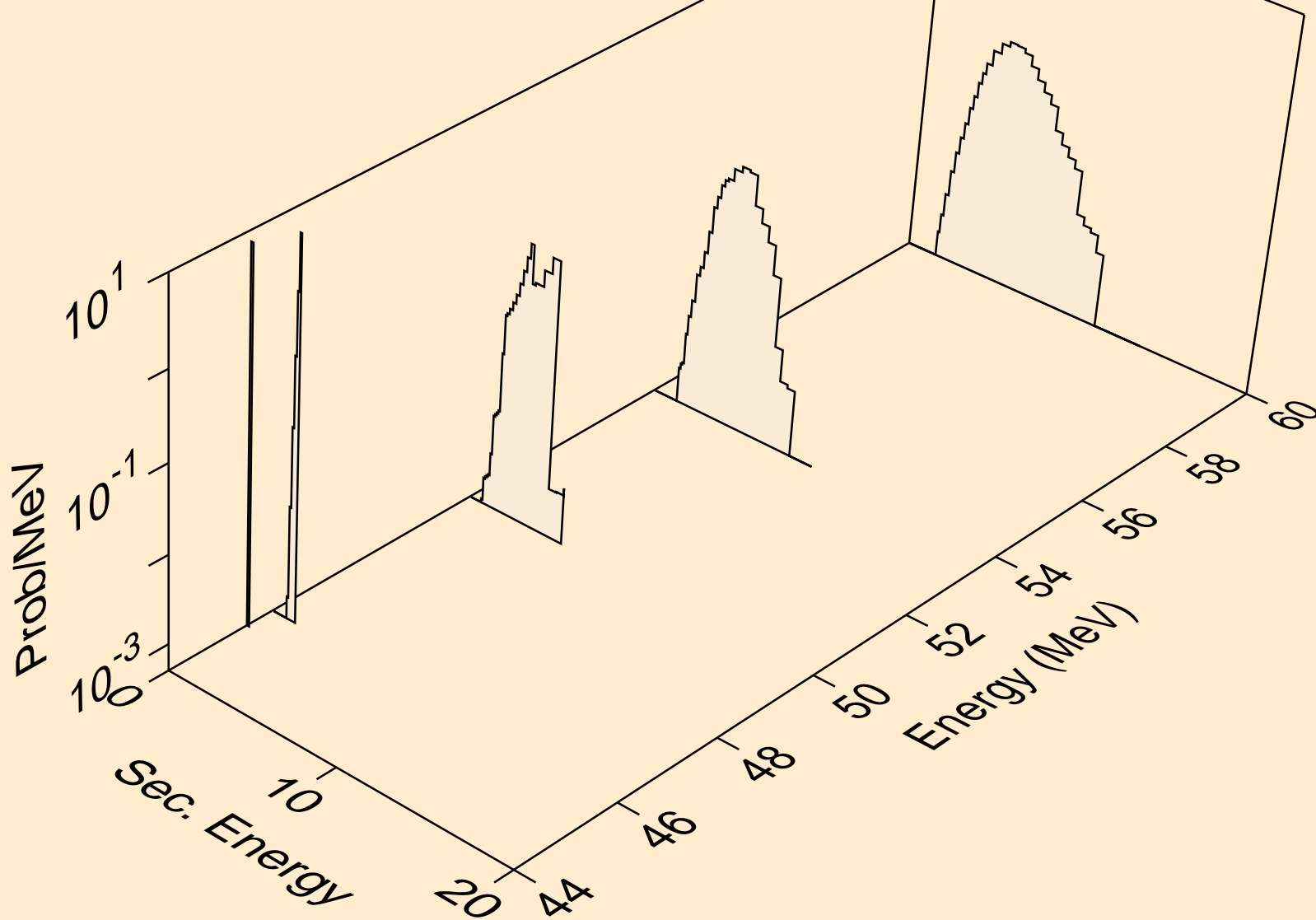

16-S-34 FOR FENDL-3.1 FROM TENDL-2010 WITH NJOY2012.50+
alphas from (n,3n2a)

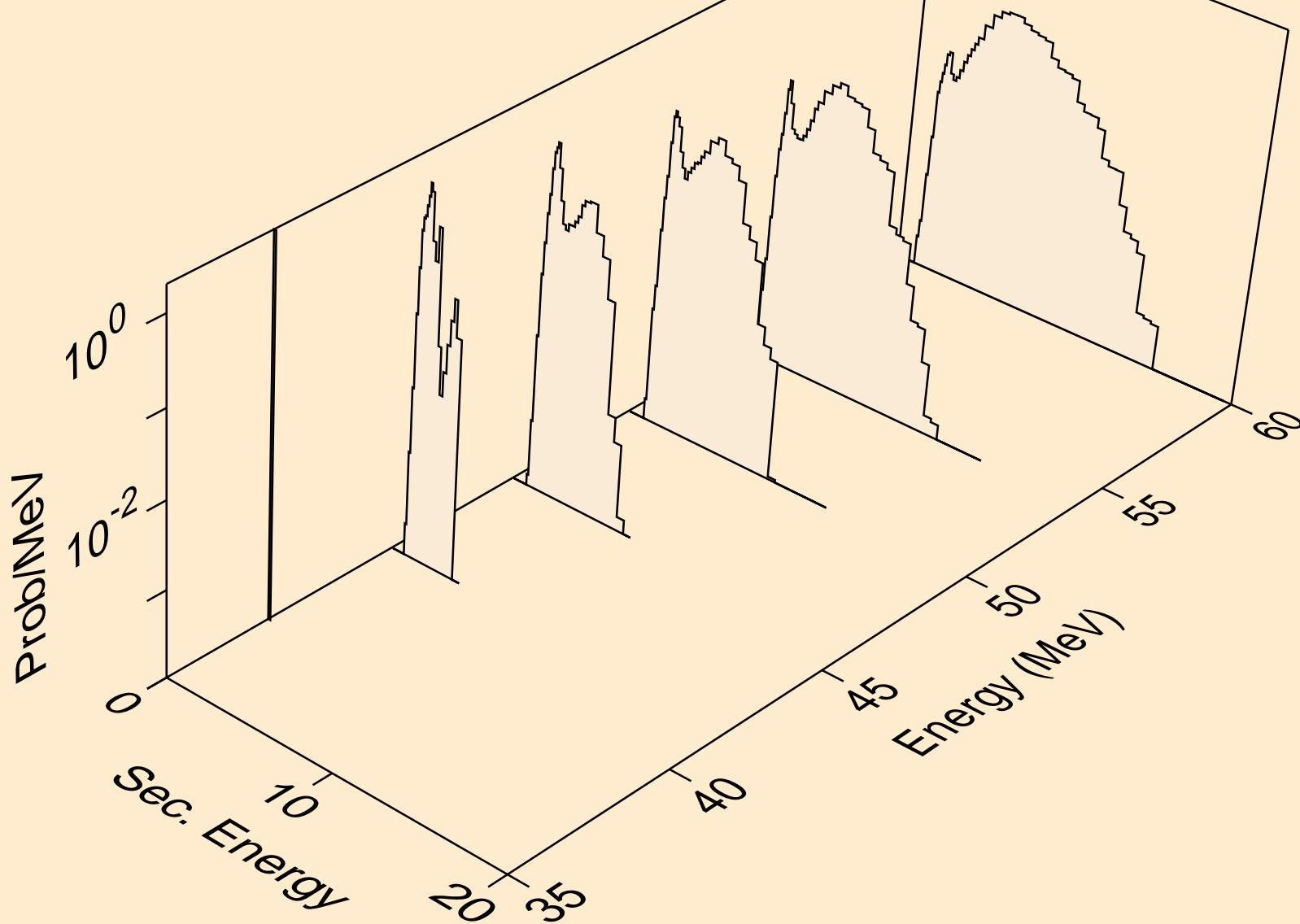

16-S-34 FOR FENDL-3.1 FROM TENDL-2010 WITH NJOY2012.50+
alphas from (n,3npa)

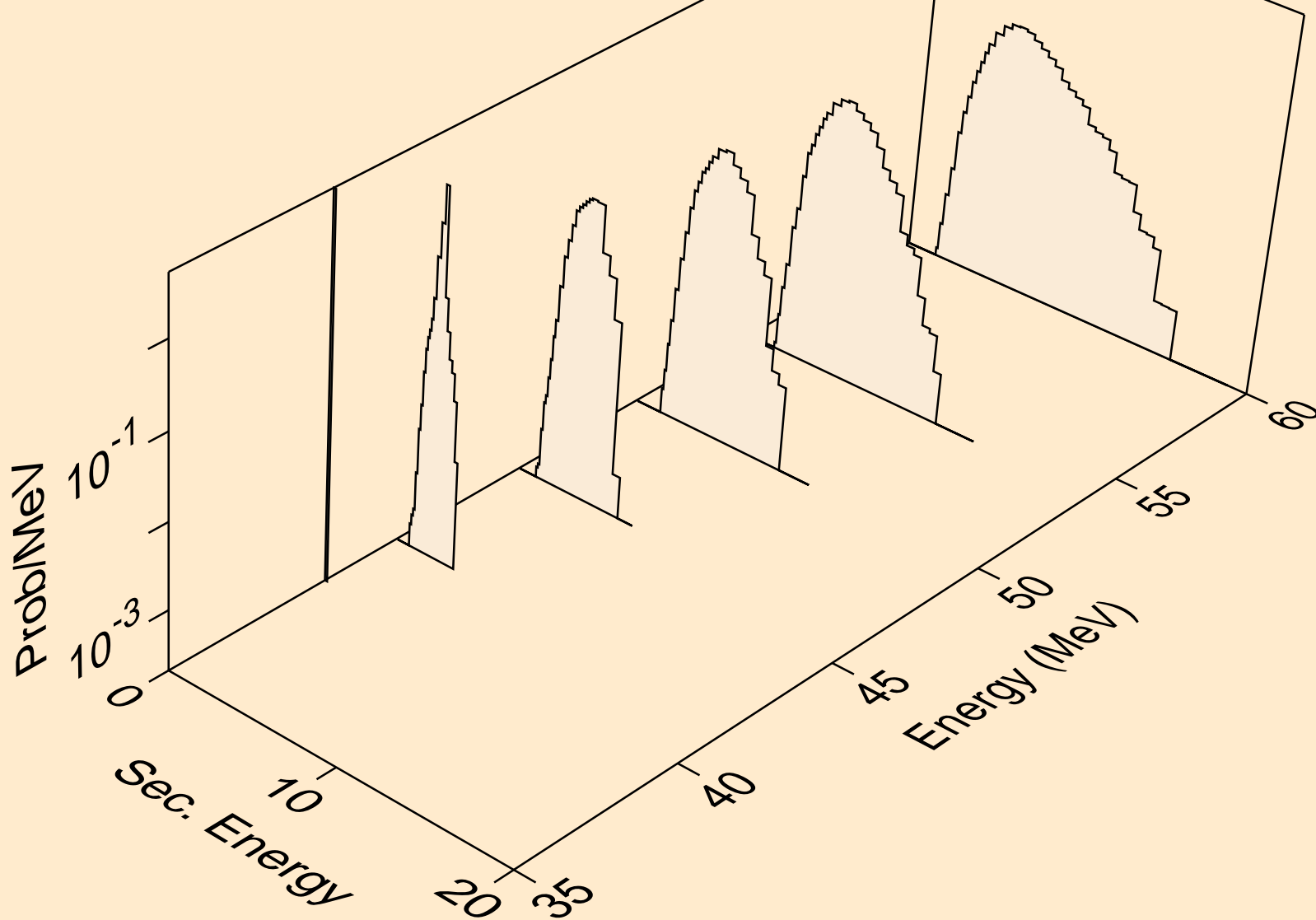

16-S-34 FOR FENDL-3.1 FROM TENDL-2010 WITH NJOY2012.50+
alphas from (n,nta)

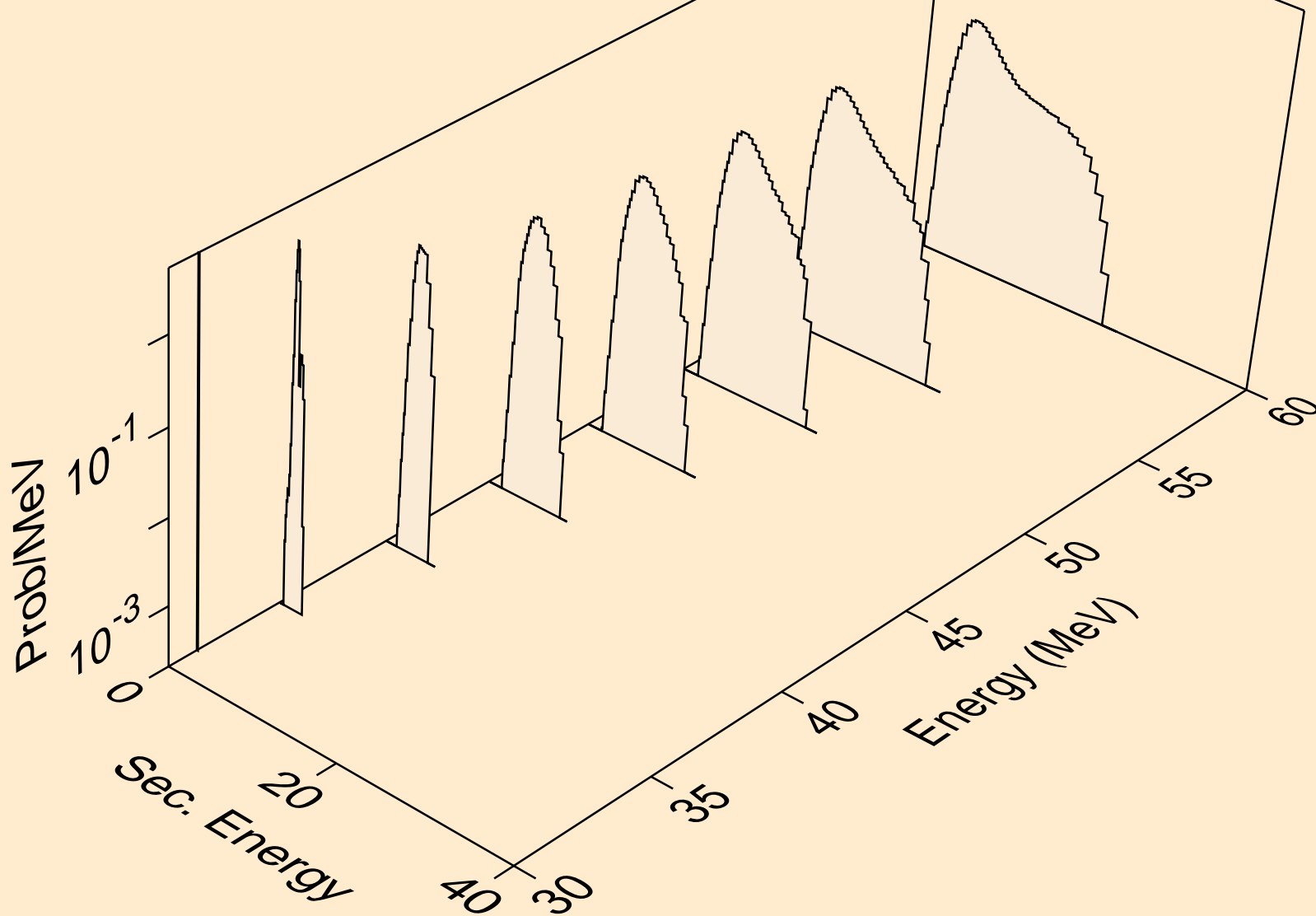

16-S-34 FOR FENDL-3.1 FROM TENDL-2010 WITH NJOY2012.50+
alphas from (n,he3a)

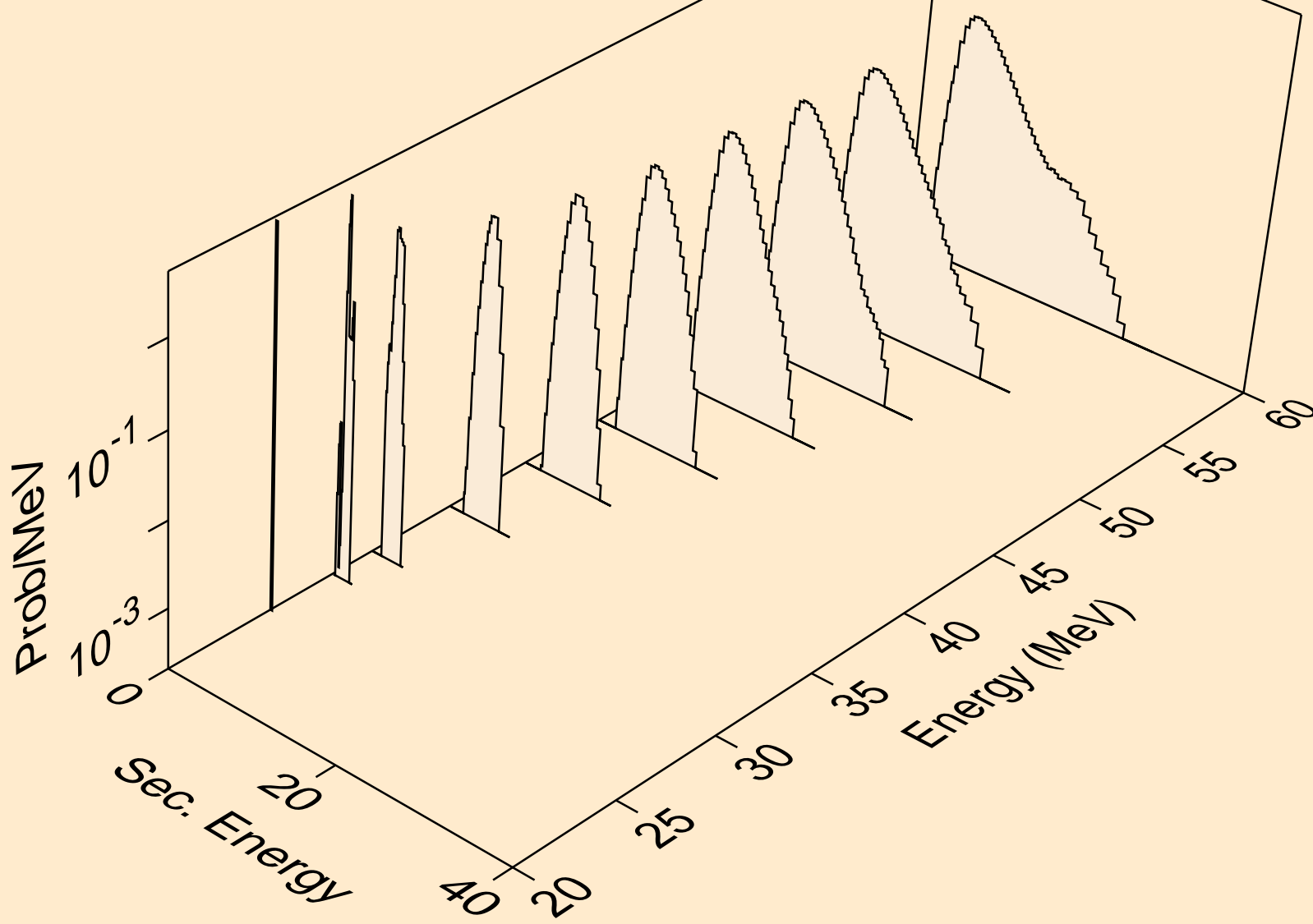

16-S-34 FOR FENDL-3.1 FROM TENDL-2010 WITH NJOY2012.50+
alphas from (n,4npa)

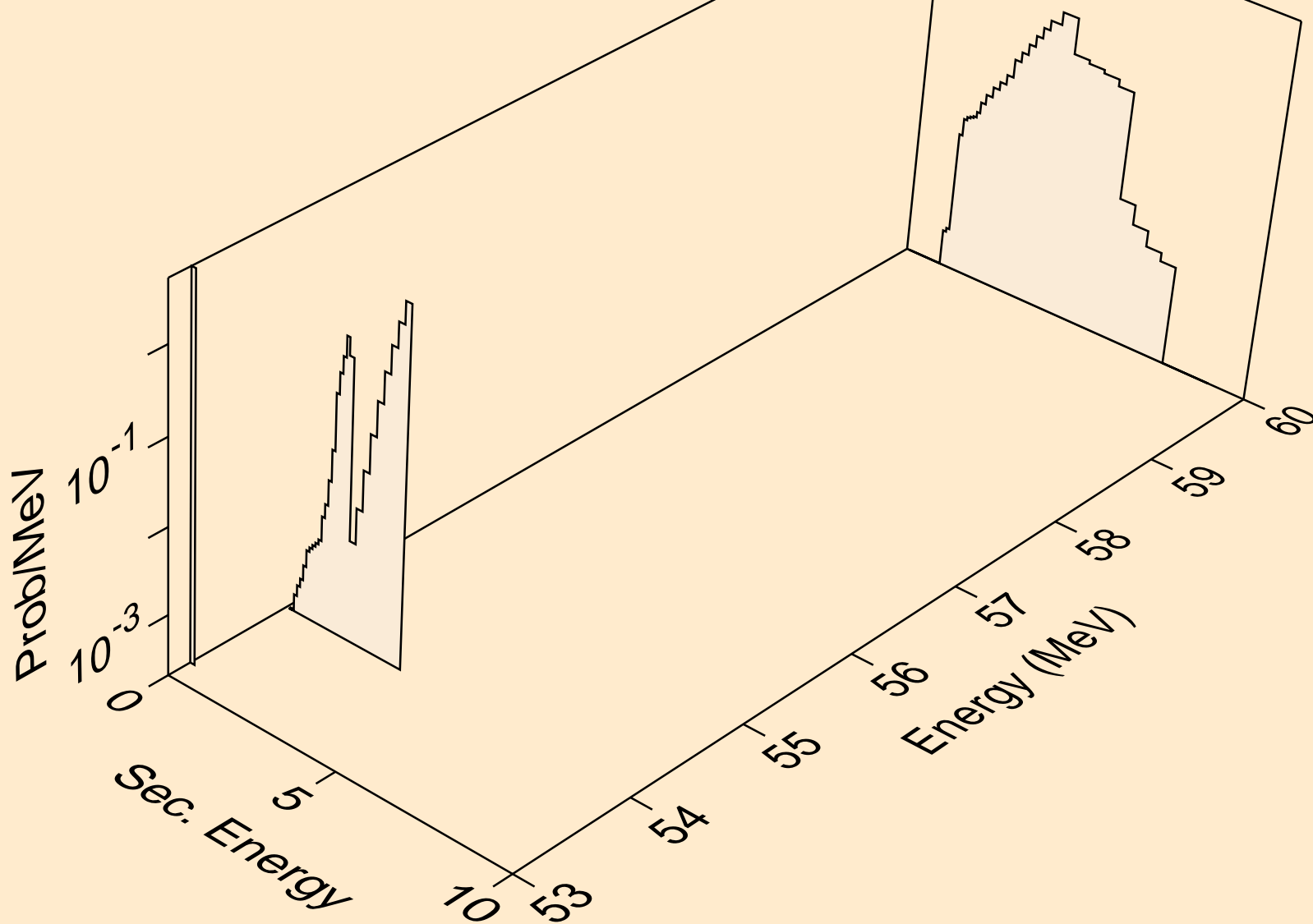

16-S-34 FOR FENDL-3.1 FROM TENDL-2010 WITH NJOY2012.50+
alphas from (n,3n2pa)

