

20-CA-42 FOR FENDL-3.1 FROM FENDL-3.1 WITH NJOY2012.50+  
Principal cross sections

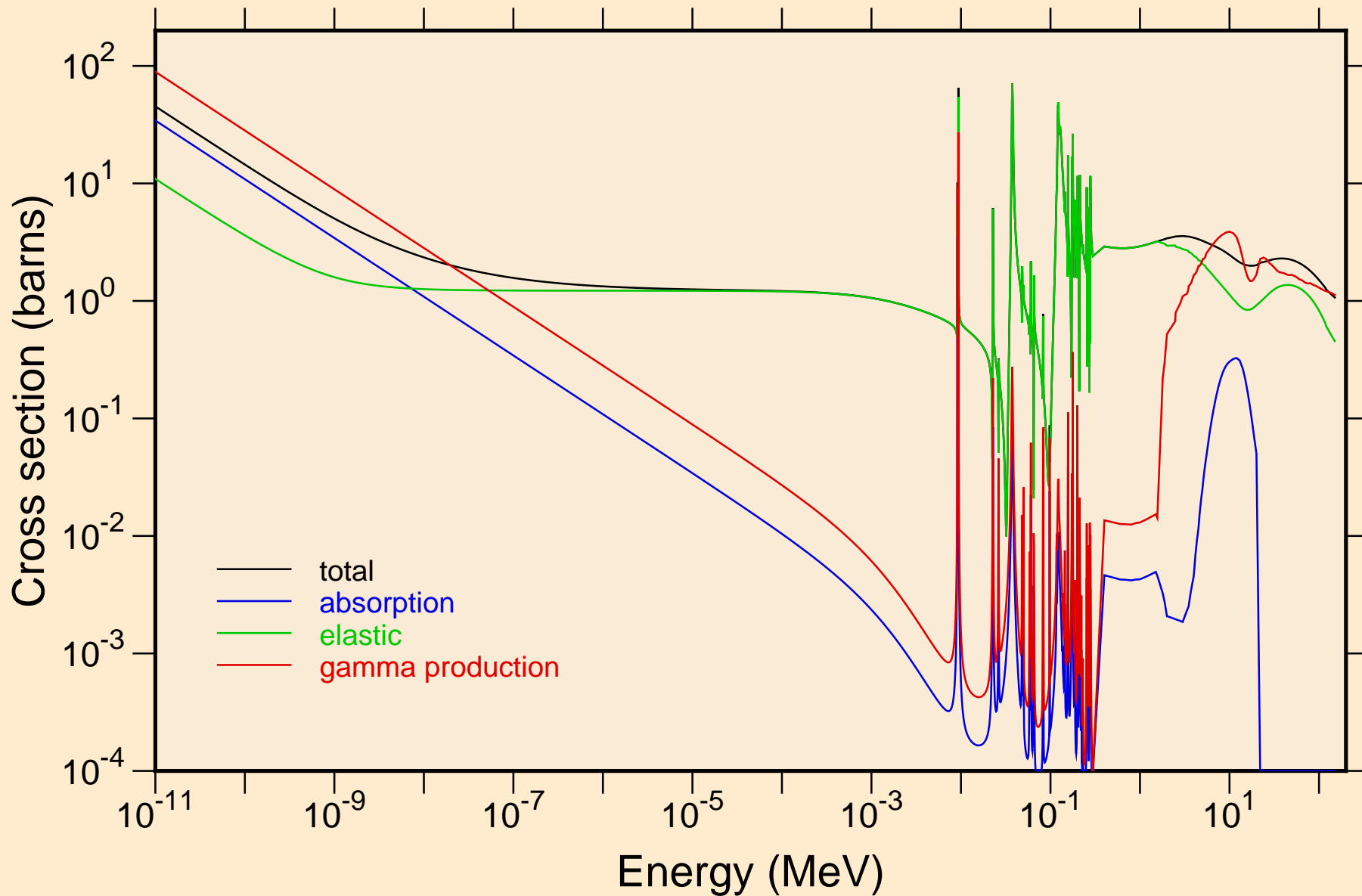

20-CA-42 FOR FENDL-3.1 FROM FENDL-3.1 WITH NJOY2012.50+  
resonance total cross section

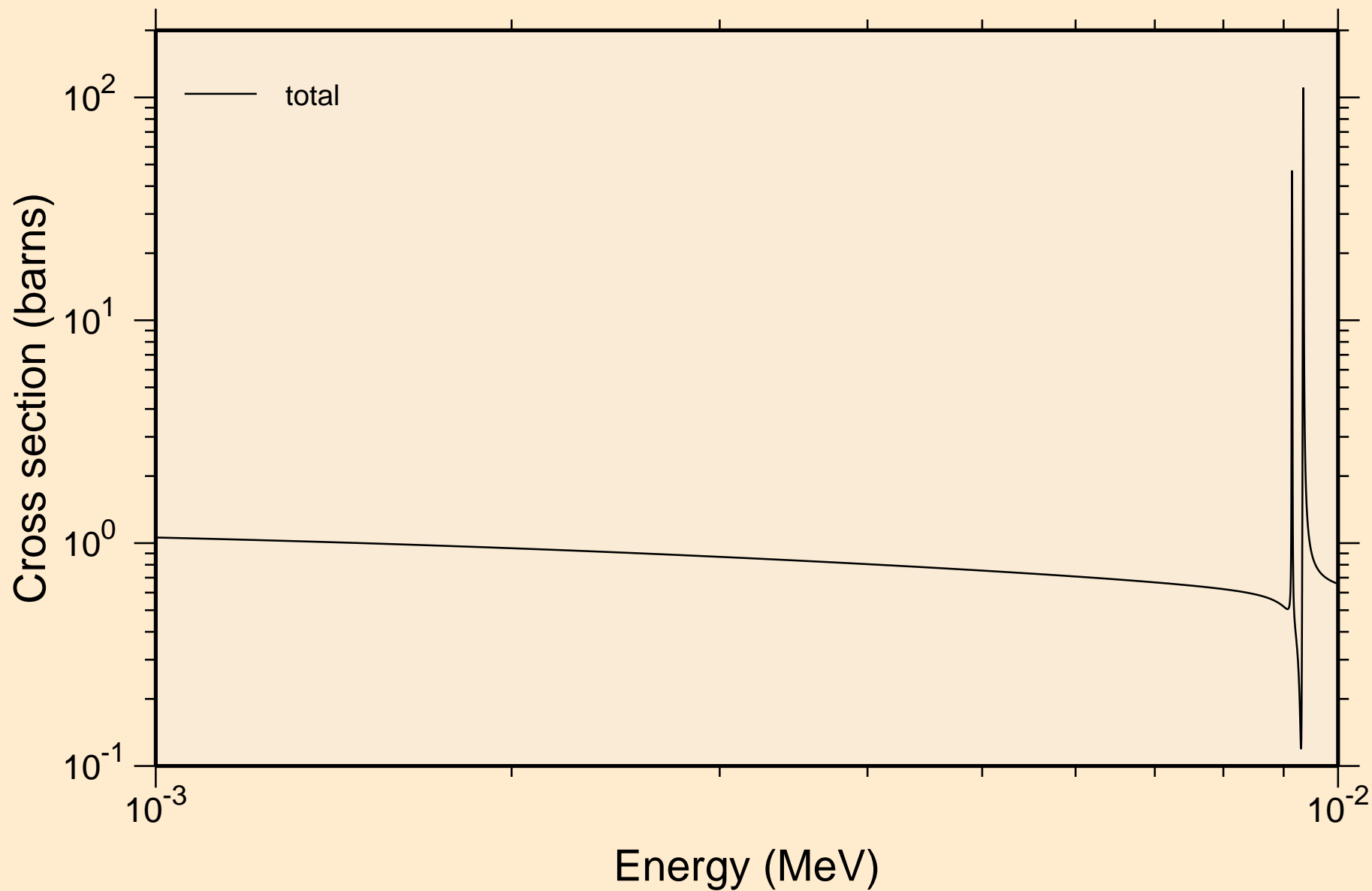

20-CA-42 FOR FENDL-3.1 FROM FENDL-3.1 WITH NJOY2012.50+  
resonance total cross section

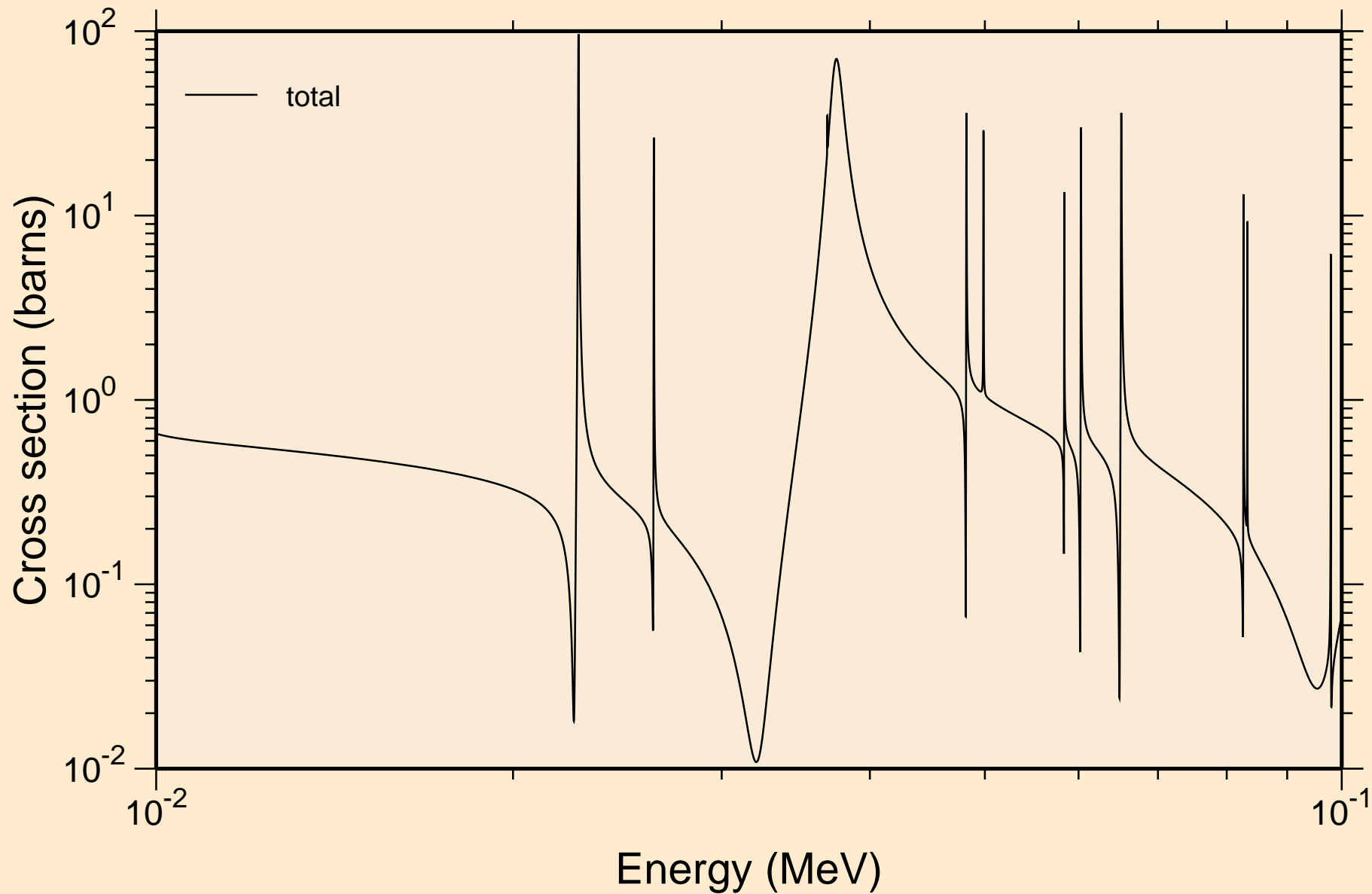

20-CA-42 FOR FENDL-3.1 FROM FENDL-3.1 WITH NJOY2012.50+  
resonance total cross section

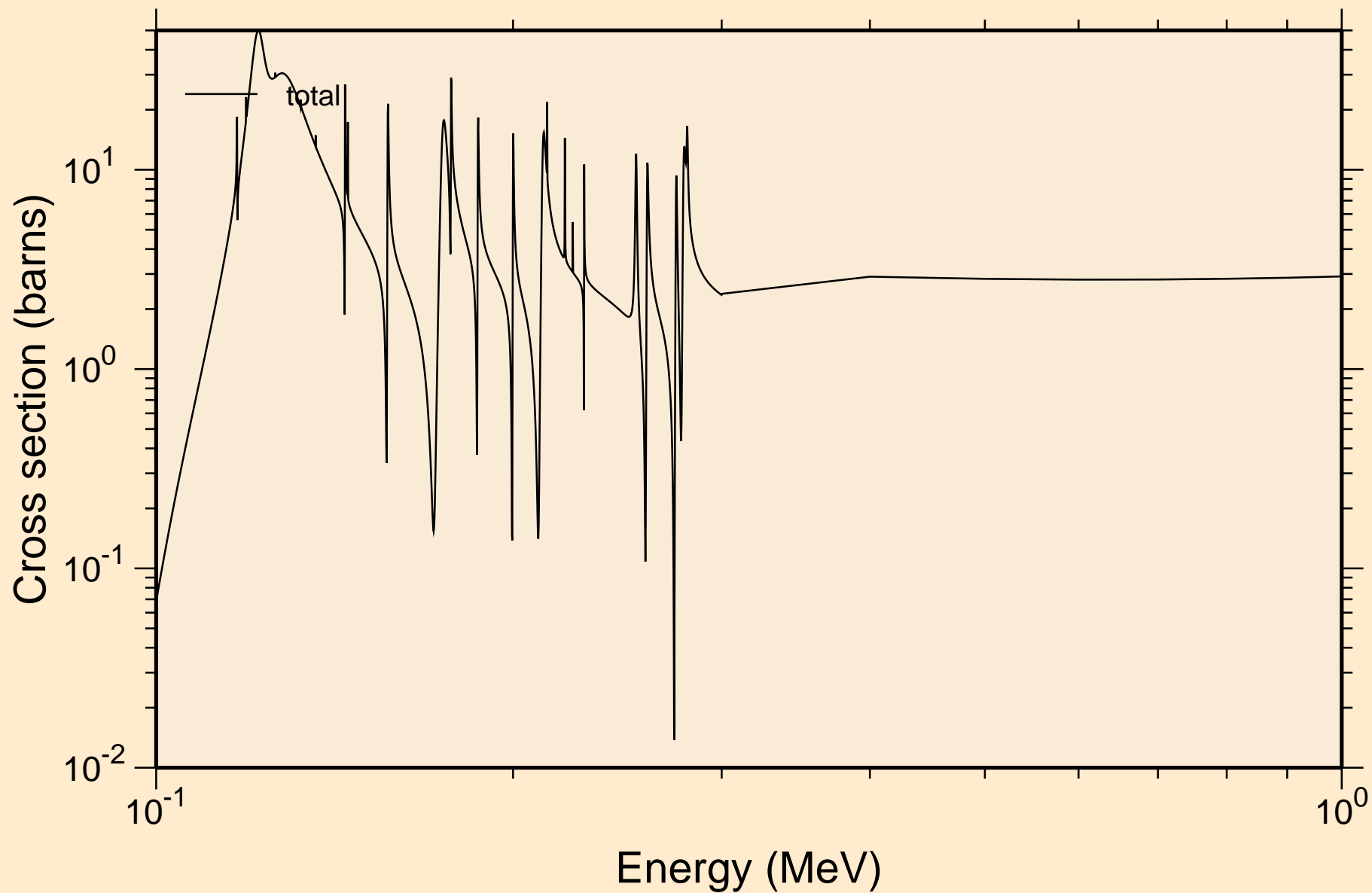

20-CA-42 FOR FENDL-3.1 FROM FENDL-3.1 WITH NJOY2012.50+  
resonance total cross section

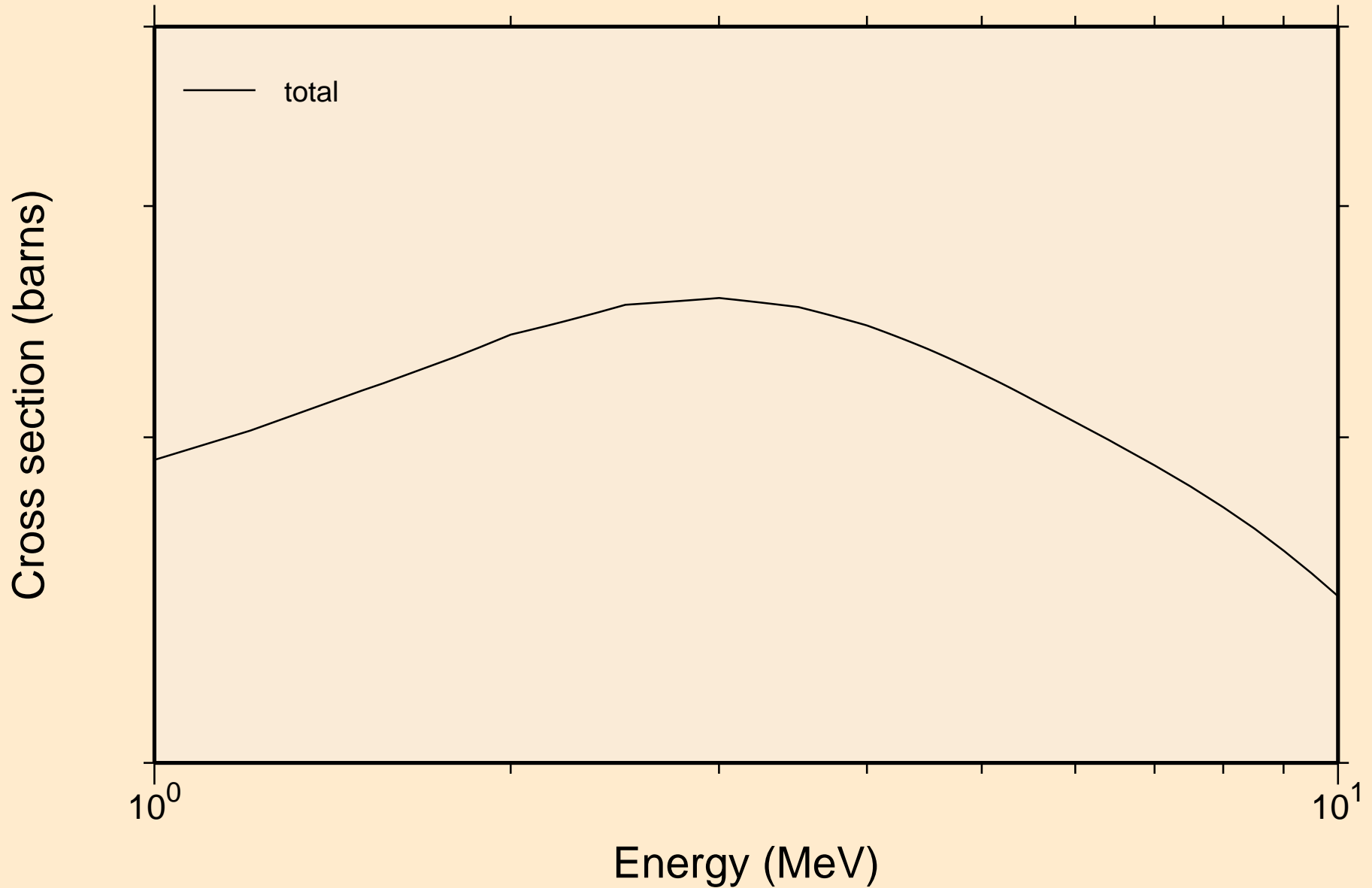

20-CA-42 FOR FENDL-3.1 FROM FENDL-3.1 WITH NJOY2012.50+  
resonance absorption cross sections

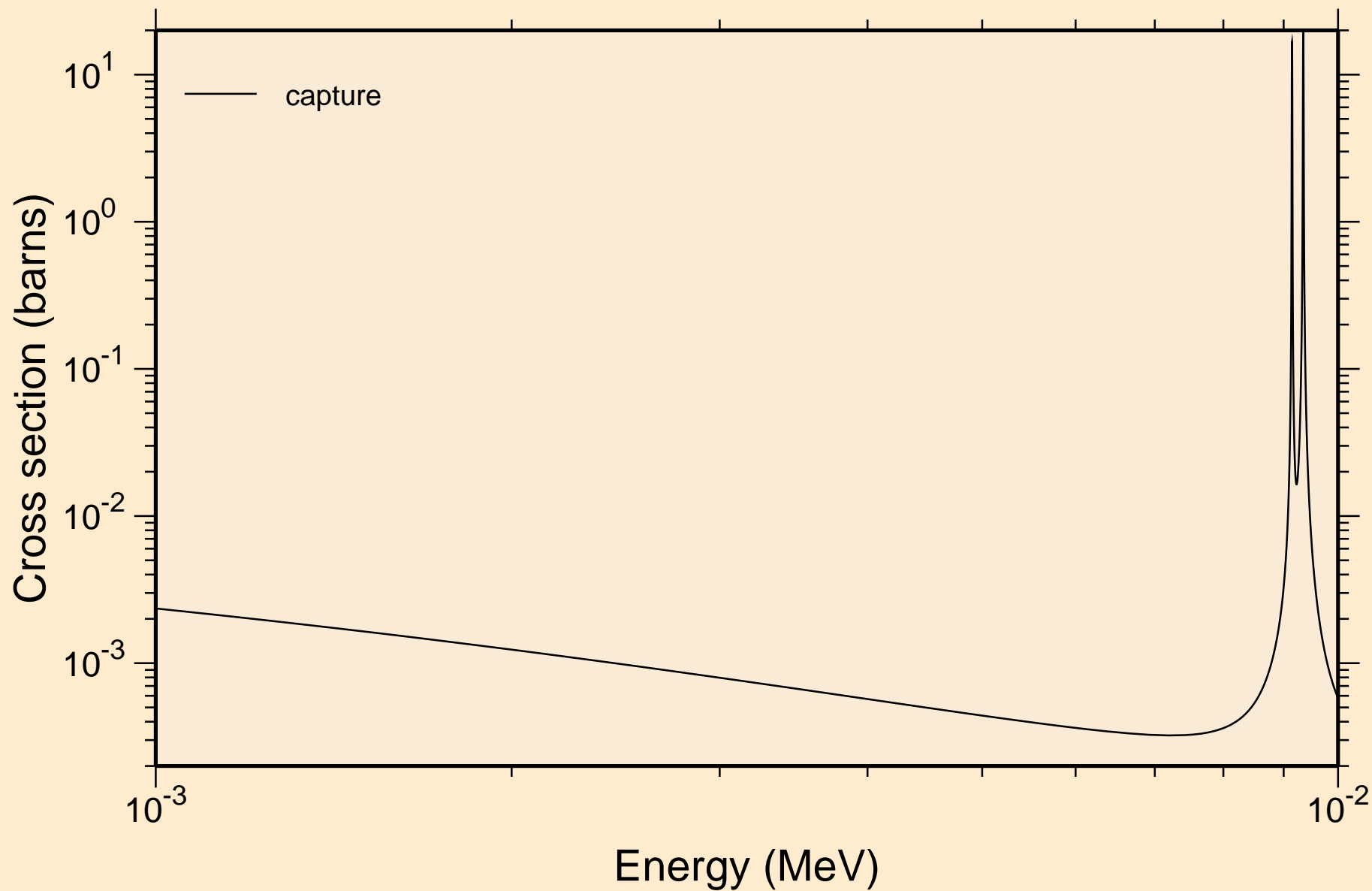

20-CA-42 FOR FENDL-3.1 FROM FENDL-3.1 WITH NJOY2012.50+  
resonance absorption cross sections

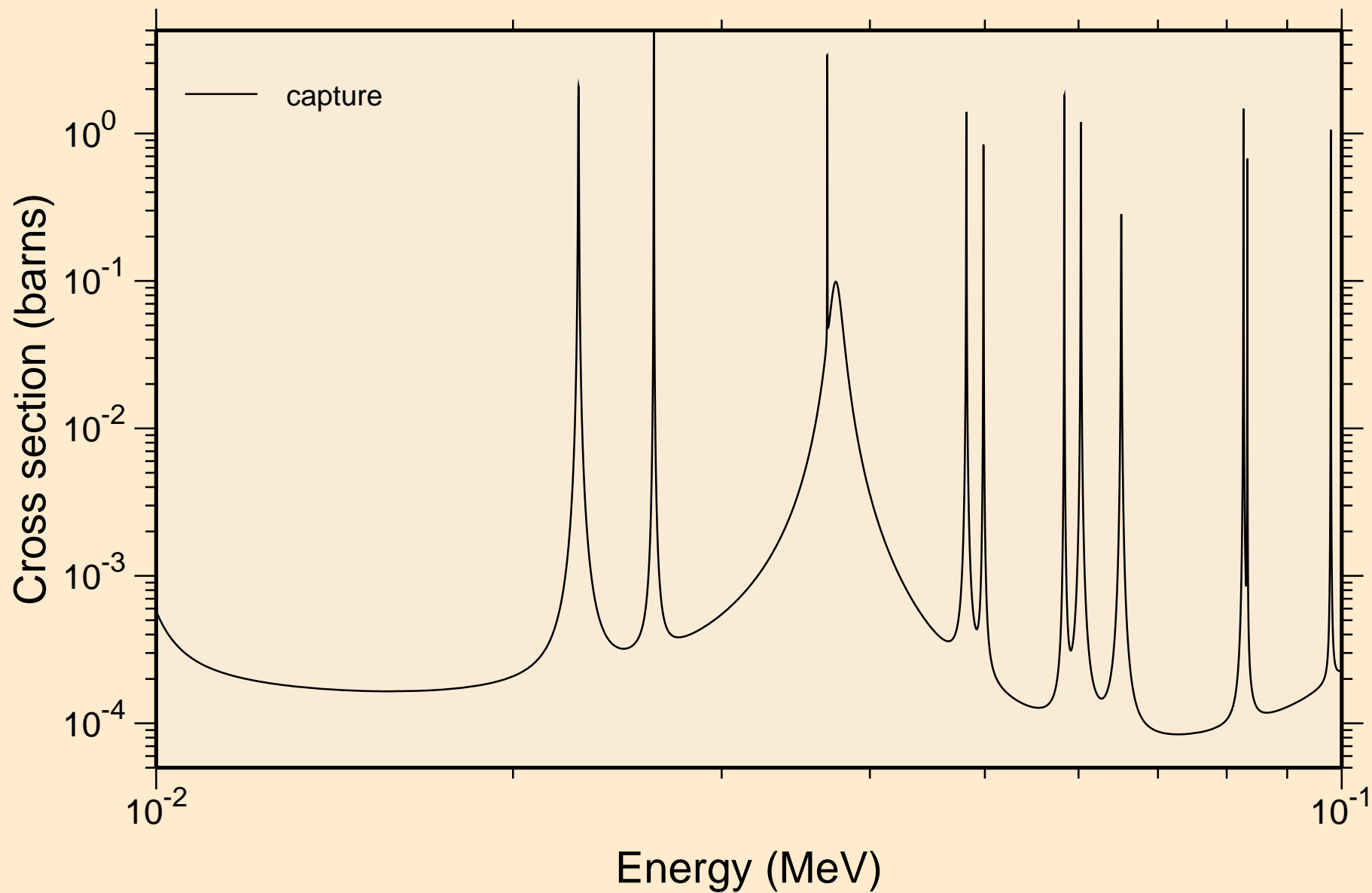

20-CA-42 FOR FENDL-3.1 FROM FENDL-3.1 WITH NJOY2012.50+  
resonance absorption cross sections

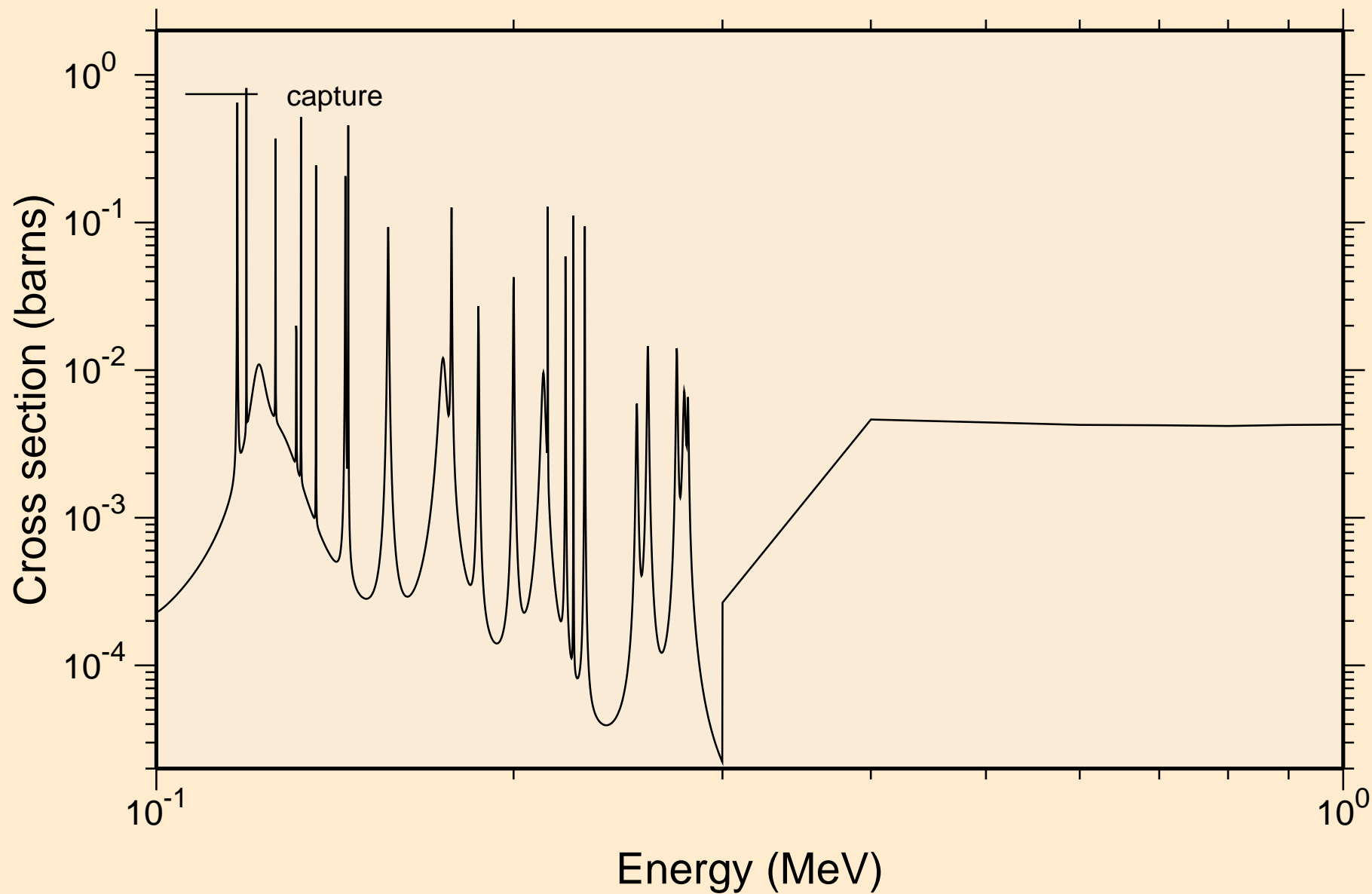



20-CA-42 FOR FENDL-3.1 FROM FENDL-3.1 WITH NJOY2012.50+  
resonance absorption cross sections

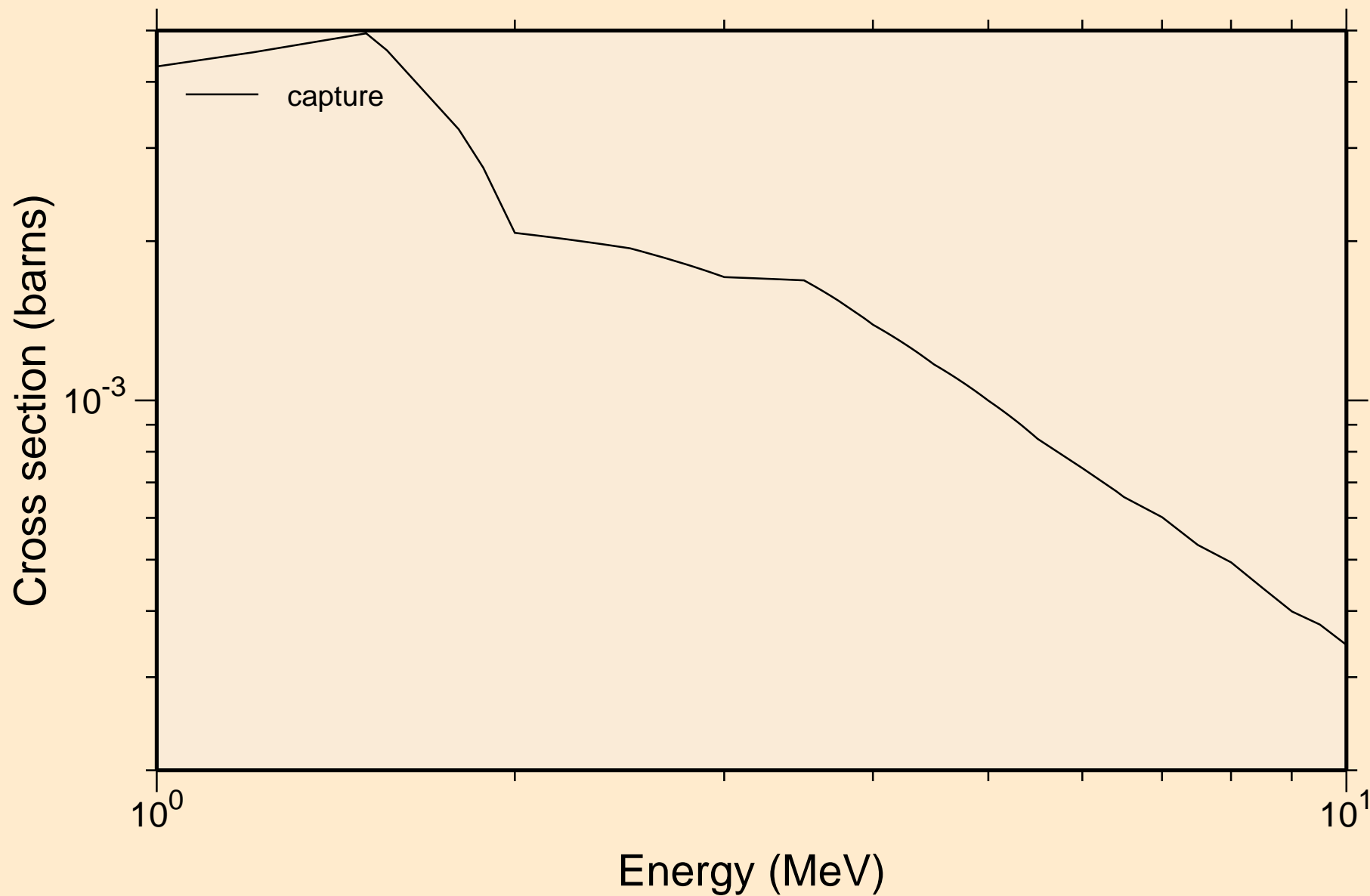

# 20-CA-42 FOR FENDL-3.1 FROM FENDL-3.1 WITH NJOY2012.50+ Heating

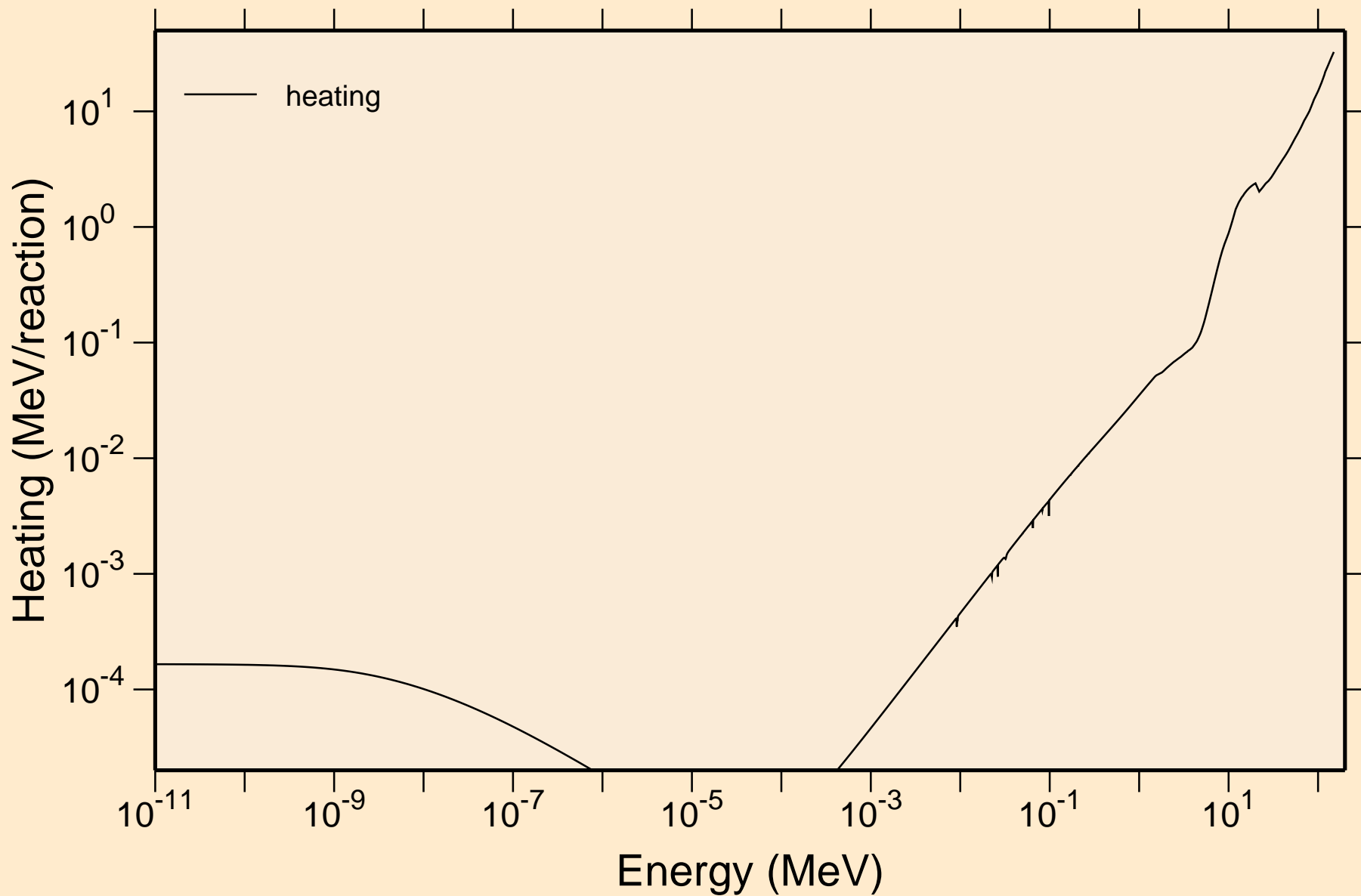

# 20-CA-42 FOR FENDL-3.1 FROM FENDL-3.1 WITH NJOY2012.50+ Damage

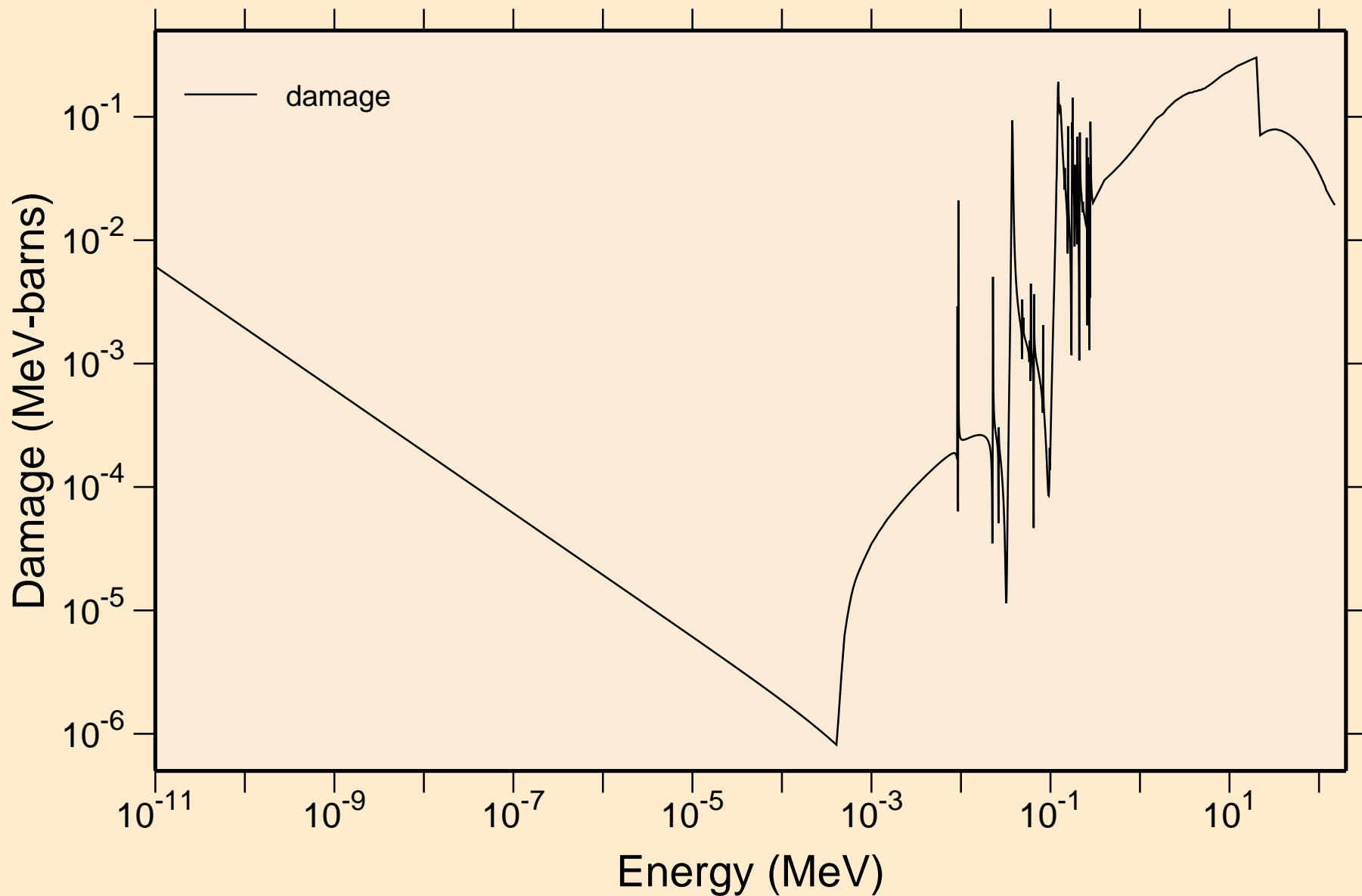

20-CA-42 FOR FENDL-3.1 FROM FENDL-3.1 WITH NJOY2012.50+  
Non-threshold reactions

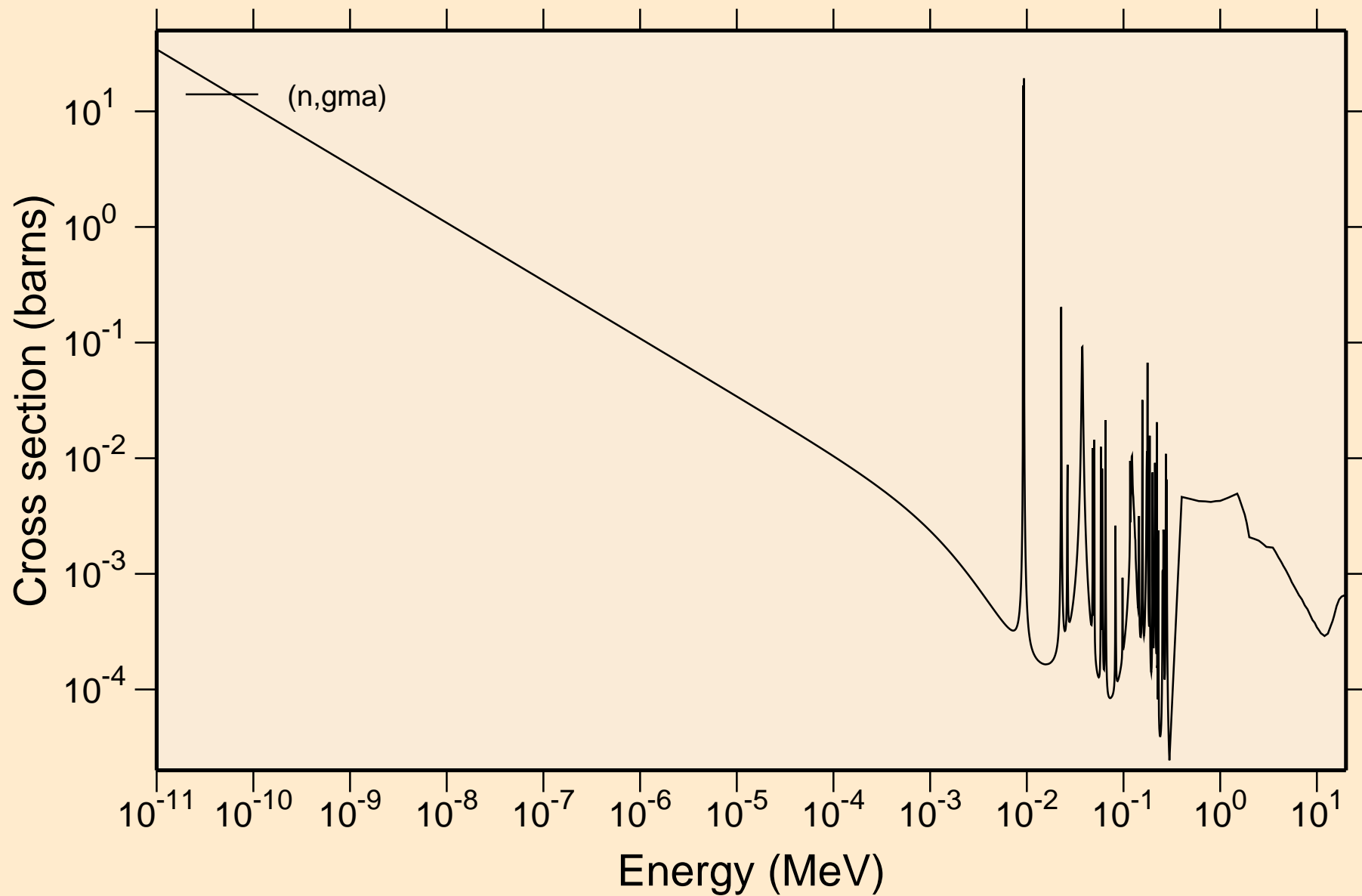

20-CA-42 FOR FENDL-3.1 FROM FENDL-3.1 WITH NJOY2012.50+  
Principal cross sections

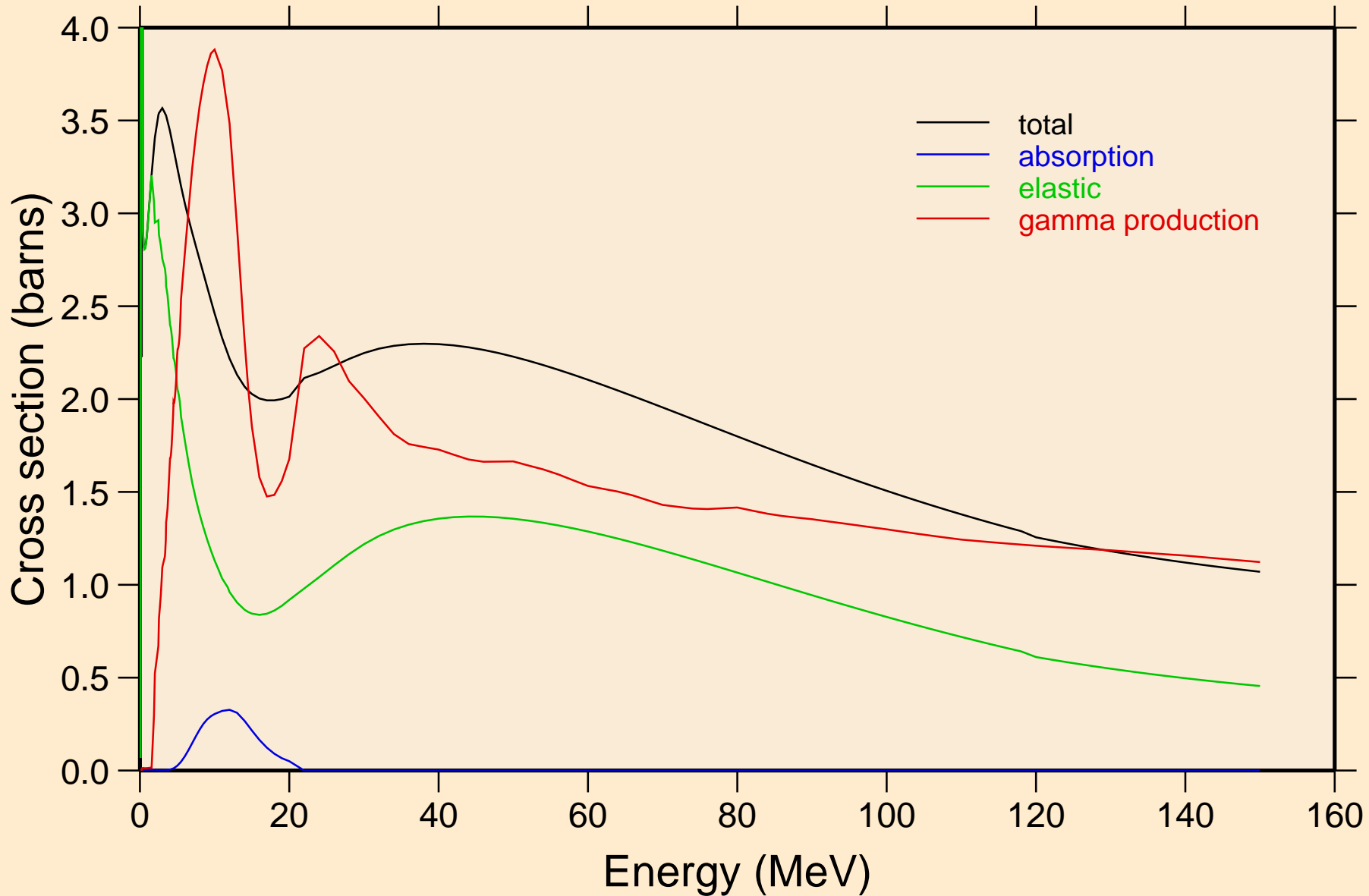

# 20-CA-42 FOR FENDL-3.1 FROM FENDL-3.1 WITH NJOY2012.50+ Heating

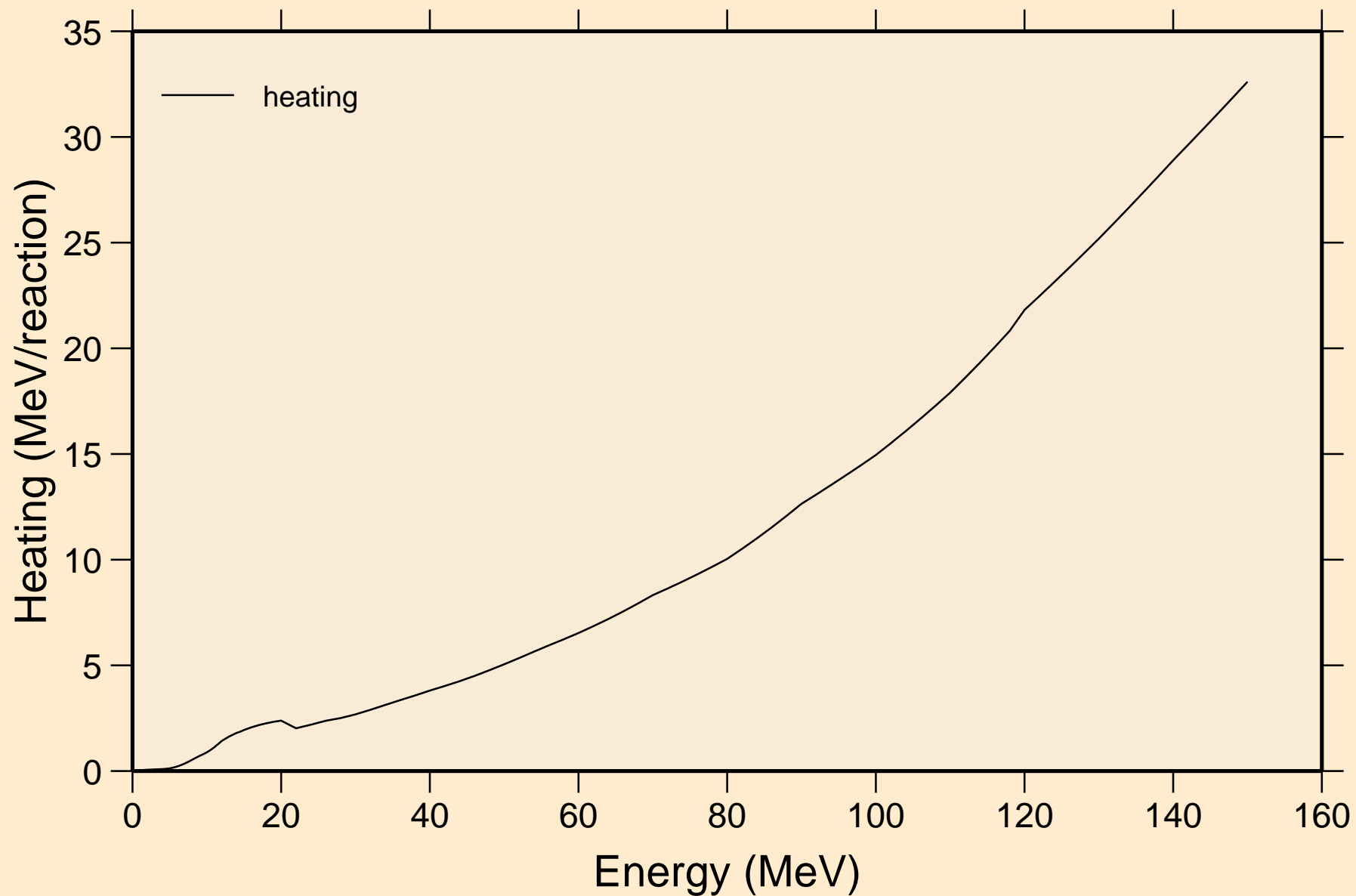

# 20-CA-42 FOR FENDL-3.1 FROM FENDL-3.1 WITH NJOY2012.50+ Damage

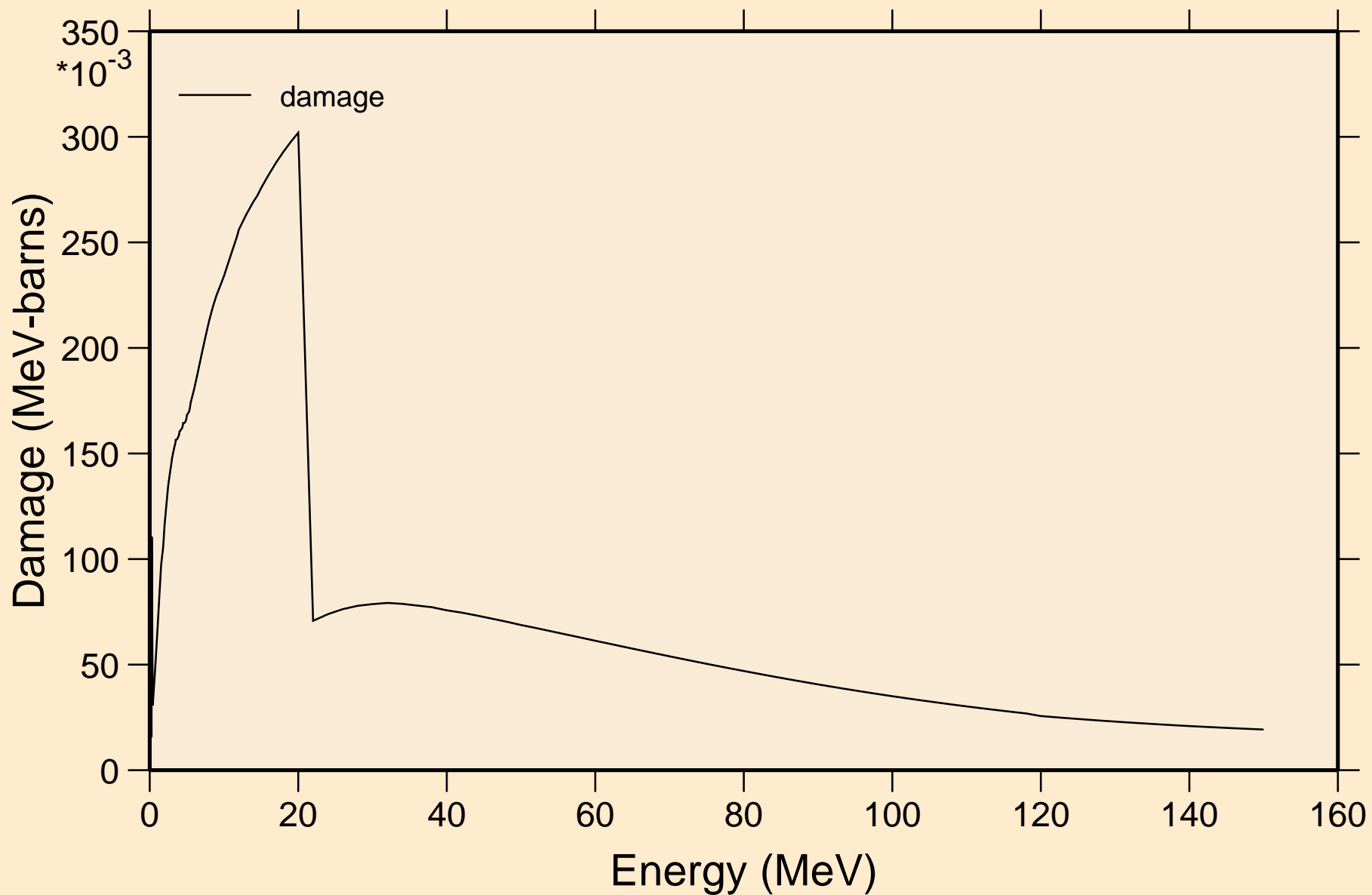

20-CA-42 FOR FENDL-3.1 FROM FENDL-3.1 WITH NJOY2012.50+  
Non-threshold reactions

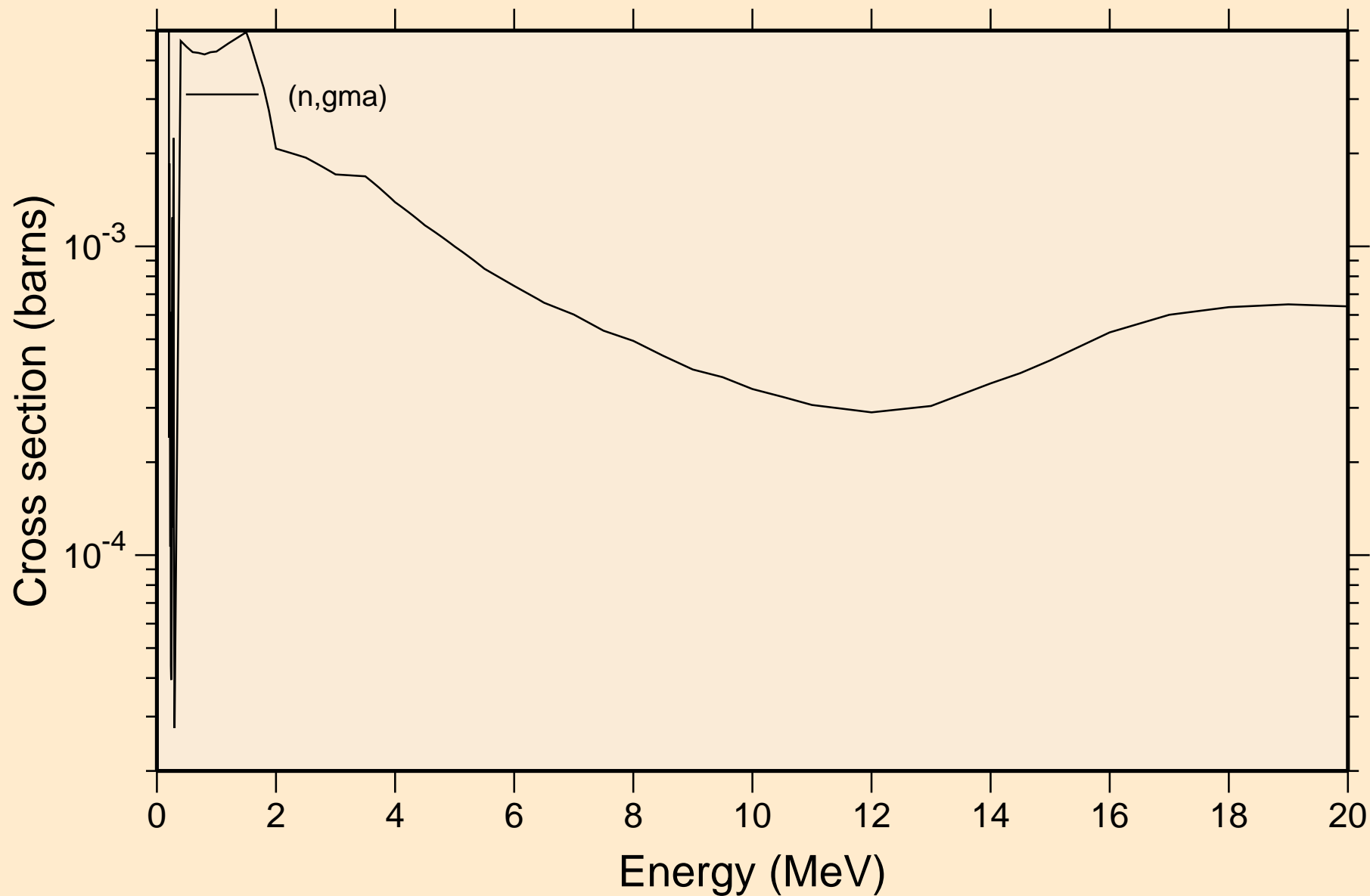



20-CA-42 FOR FENDL-3.1 FROM FENDL-3.1 WITH NJOY2012.50+  
Inelastic levels

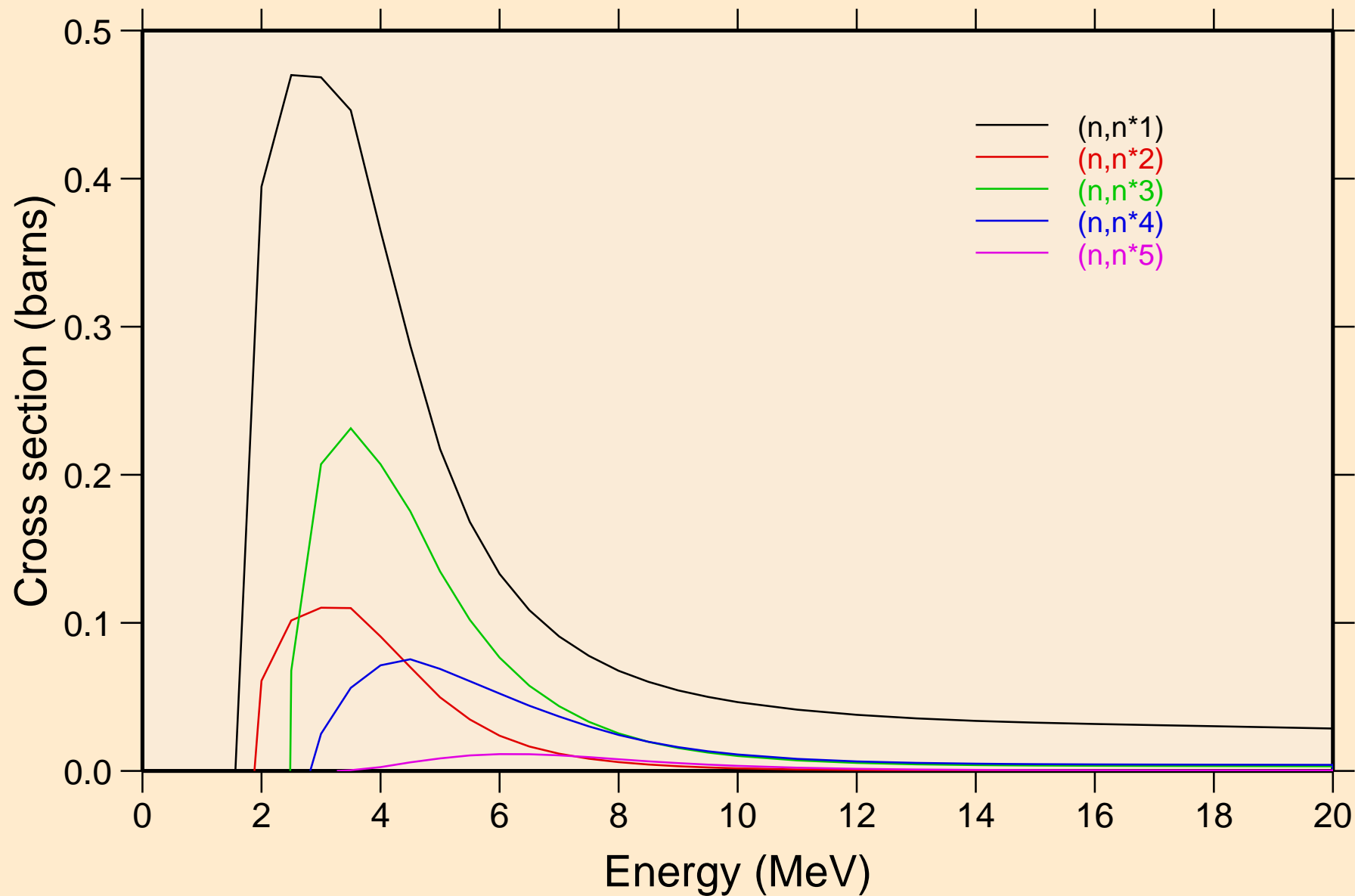

# 20-CA-42 FOR FENDL-3.1 FROM FENDL-3.1 WITH NJOY2012.50+ Inelastic levels

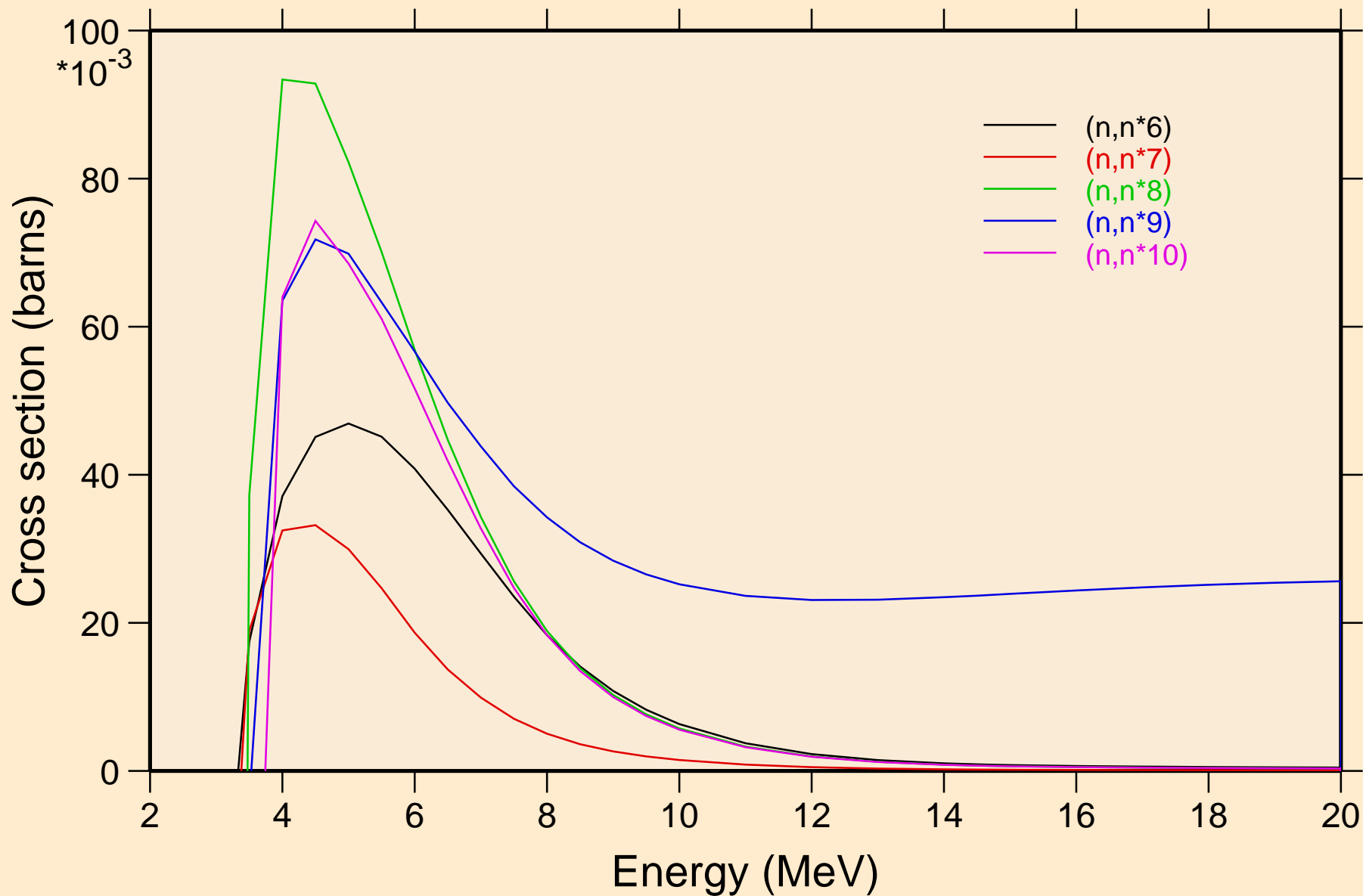

# 20-CA-42 FOR FENDL-3.1 FROM FENDL-3.1 WITH NJOY2012.50+ Inelastic levels

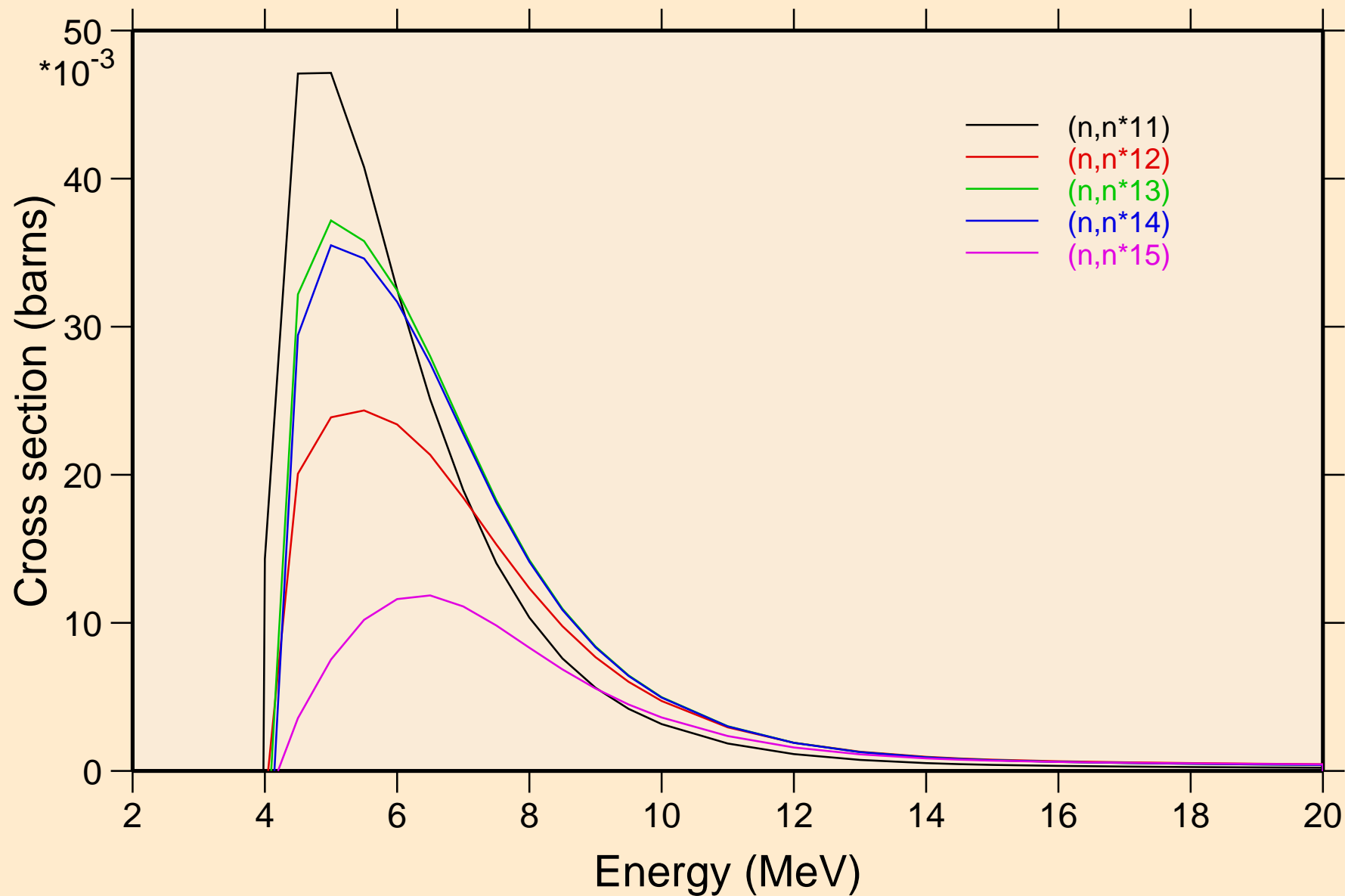

# 20-CA-42 FOR FENDL-3.1 FROM FENDL-3.1 WITH NJOY2012.50+ Inelastic levels

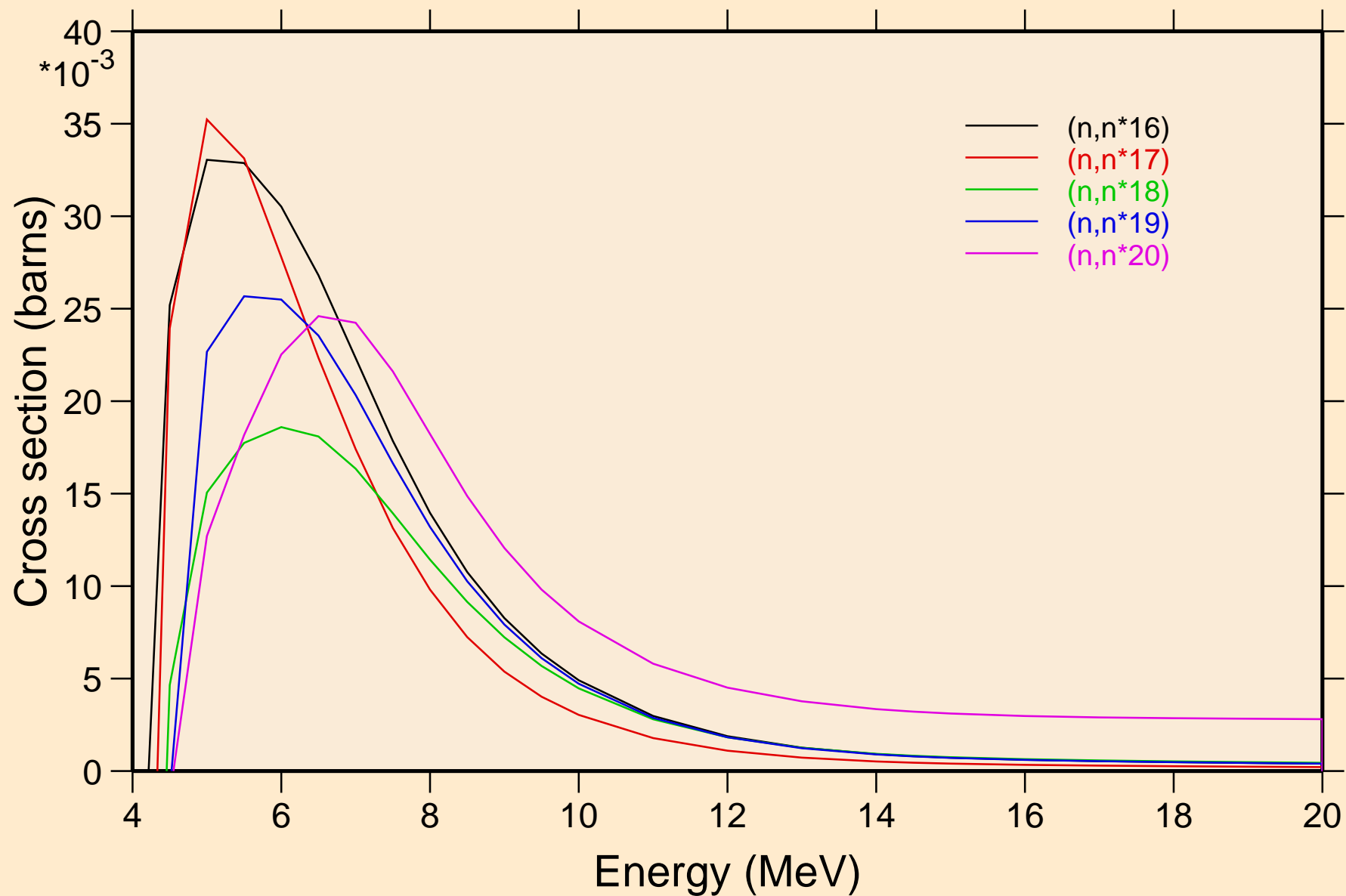

# 20-CA-42 FOR FENDL-3.1 FROM FENDL-3.1 WITH NJOY2012.50+ Inelastic levels

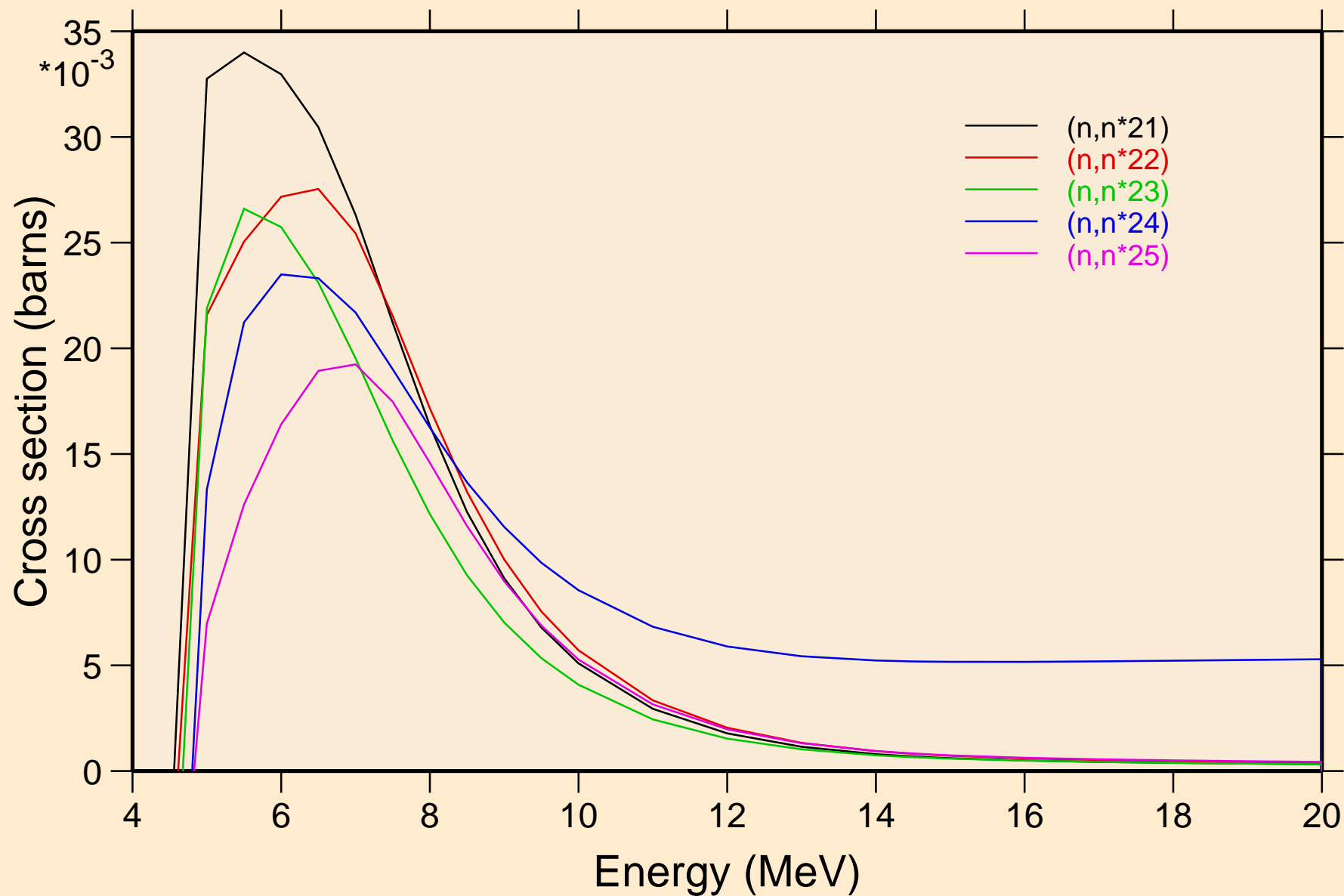

# 20-CA-42 FOR FENDL-3.1 FROM FENDL-3.1 WITH NJOY2012.50+ Inelastic levels

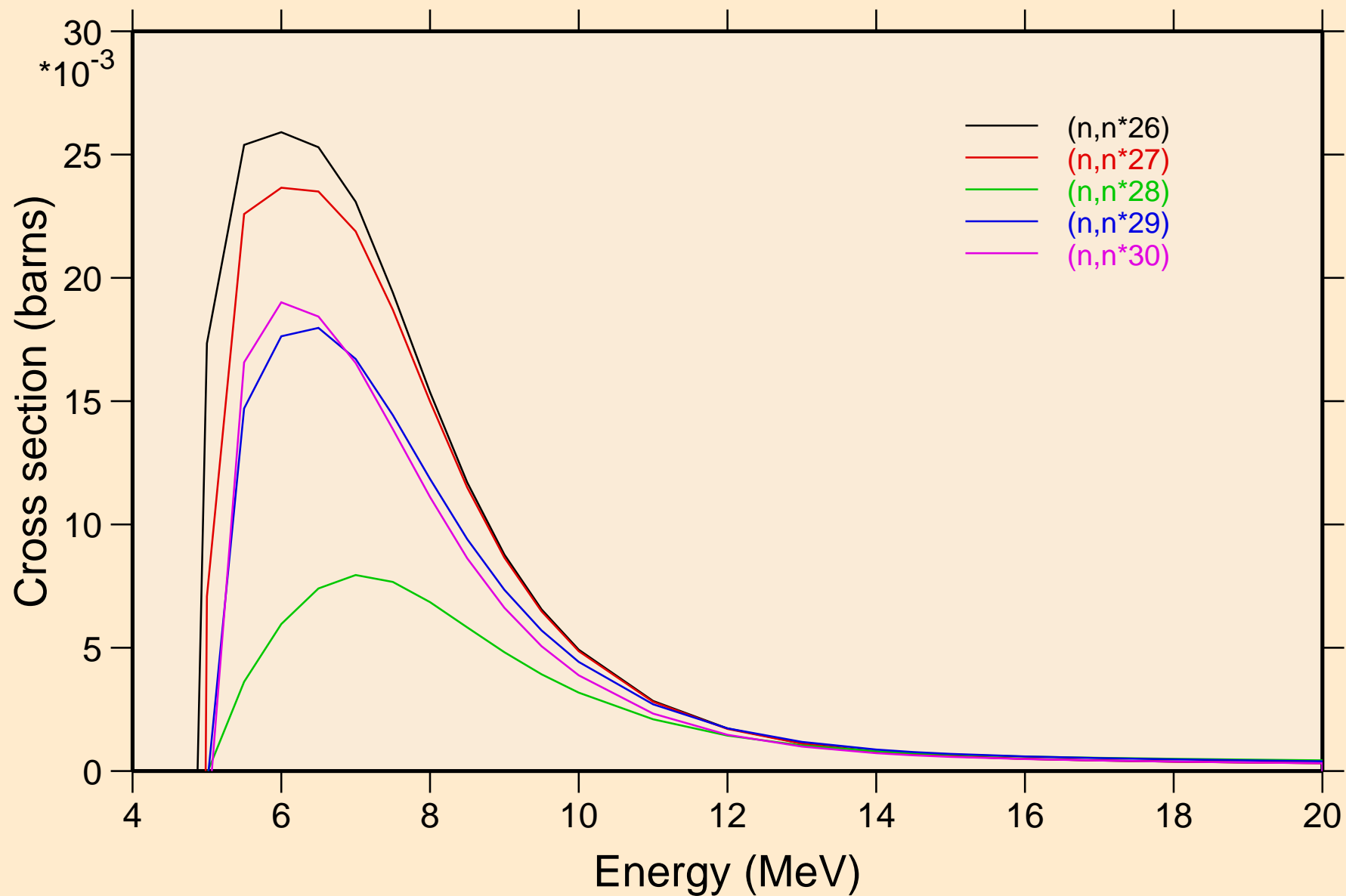

20-CA-42 FOR FENDL-3.1 FROM FENDL-3.1 WITH NJOY2012.50+  
Inelastic levels

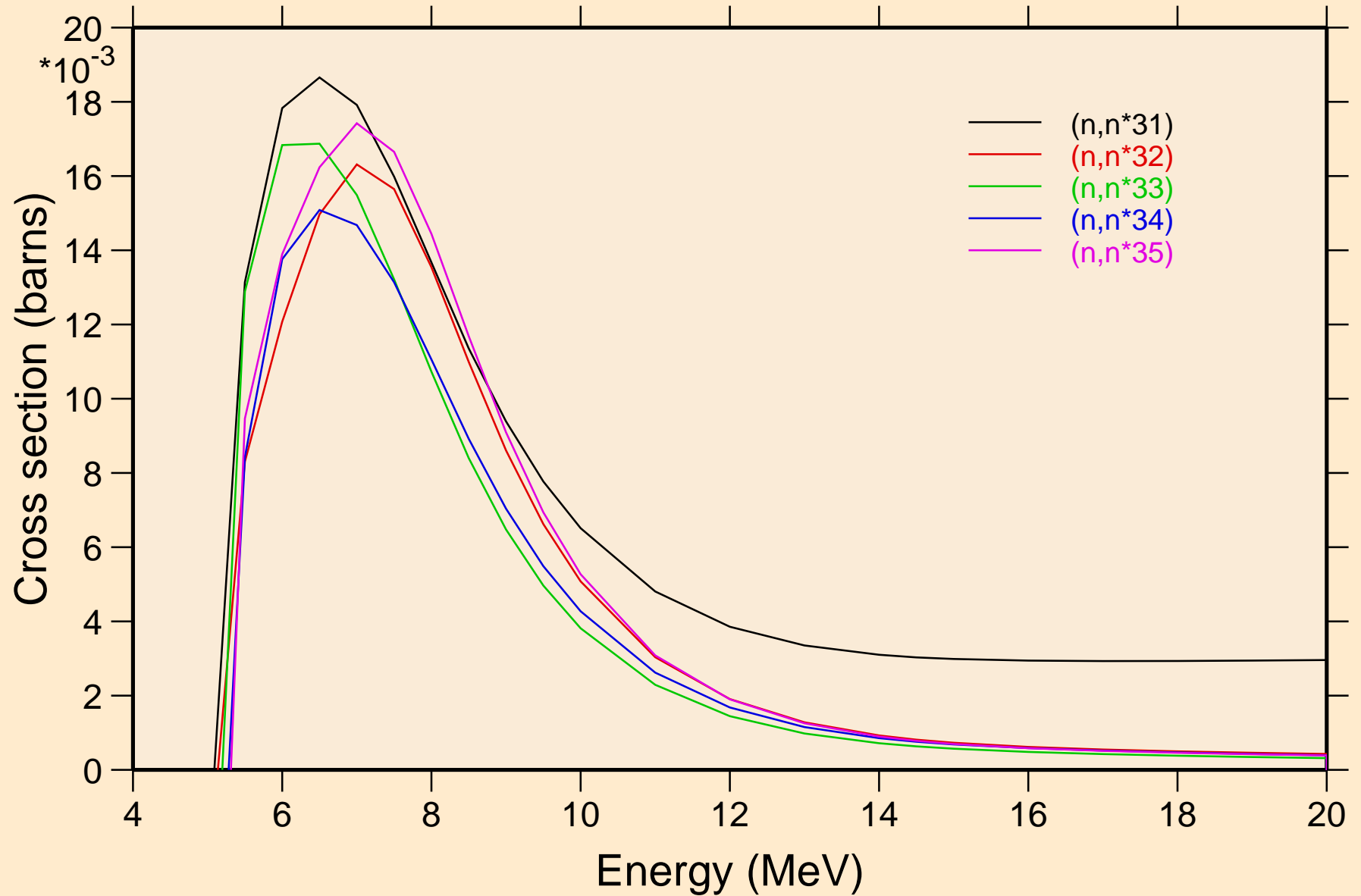

# 20-CA-42 FOR FENDL-3.1 FROM FENDL-3.1 WITH NJOY2012.50+ Inelastic levels

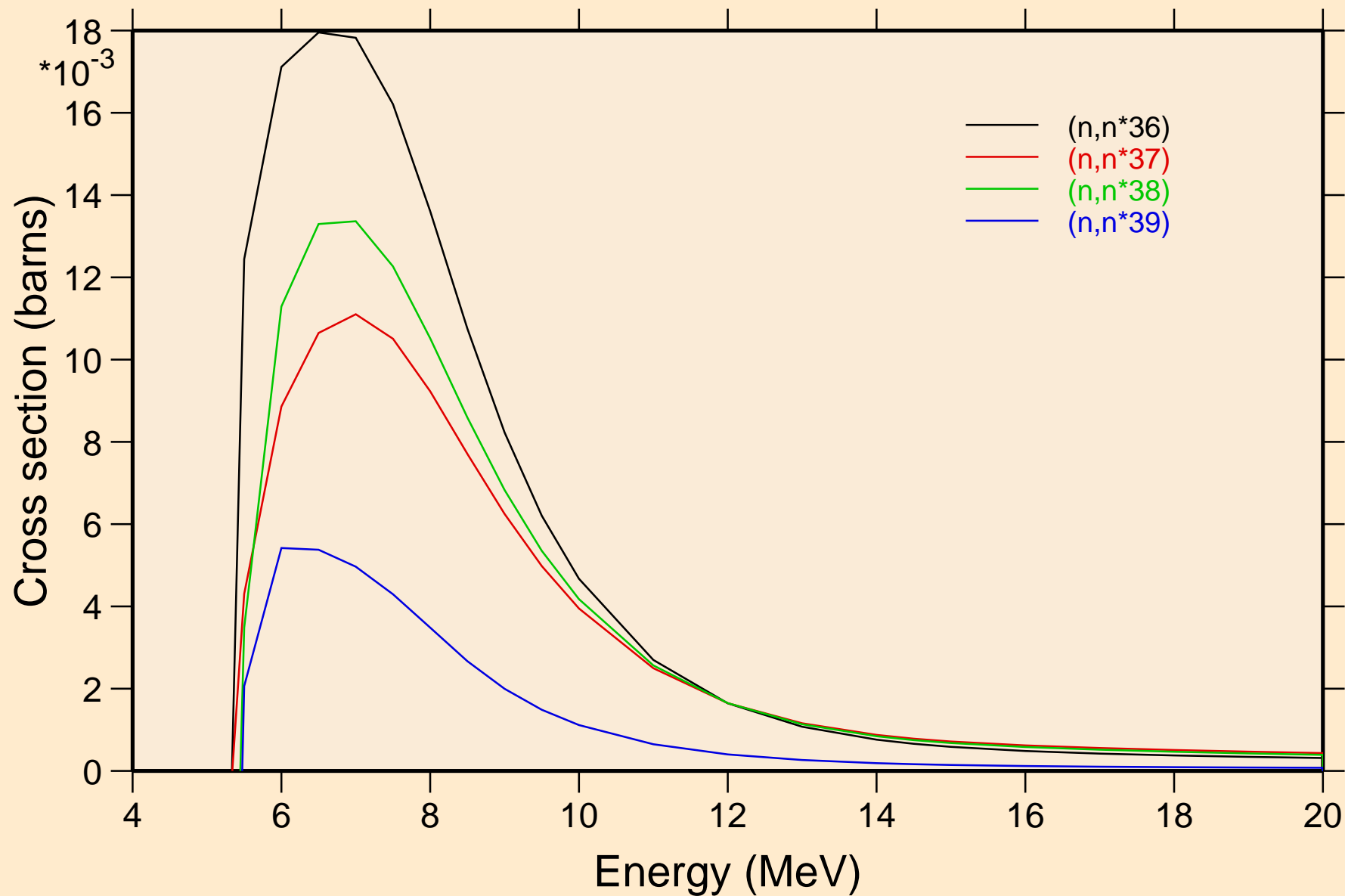



# 20-CA-42 FOR FENDL-3.1 FROM FENDL-3.1 WITH NJOY2012.50+ Threshold reactions

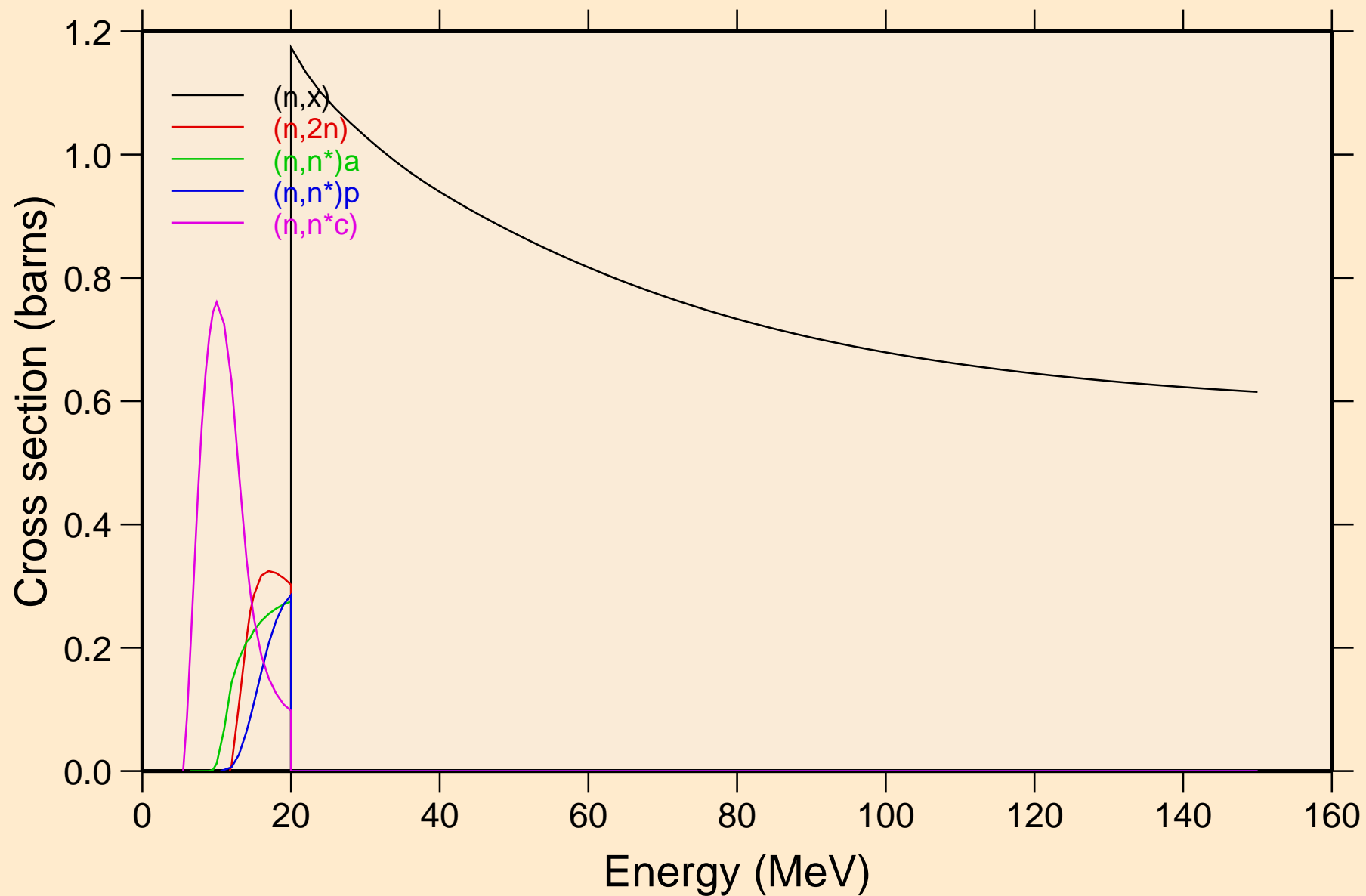

20-CA-42 FOR FENDL-3.1 FROM FENDL-3.1 WITH NJOY2012.50+  
Threshold reactions

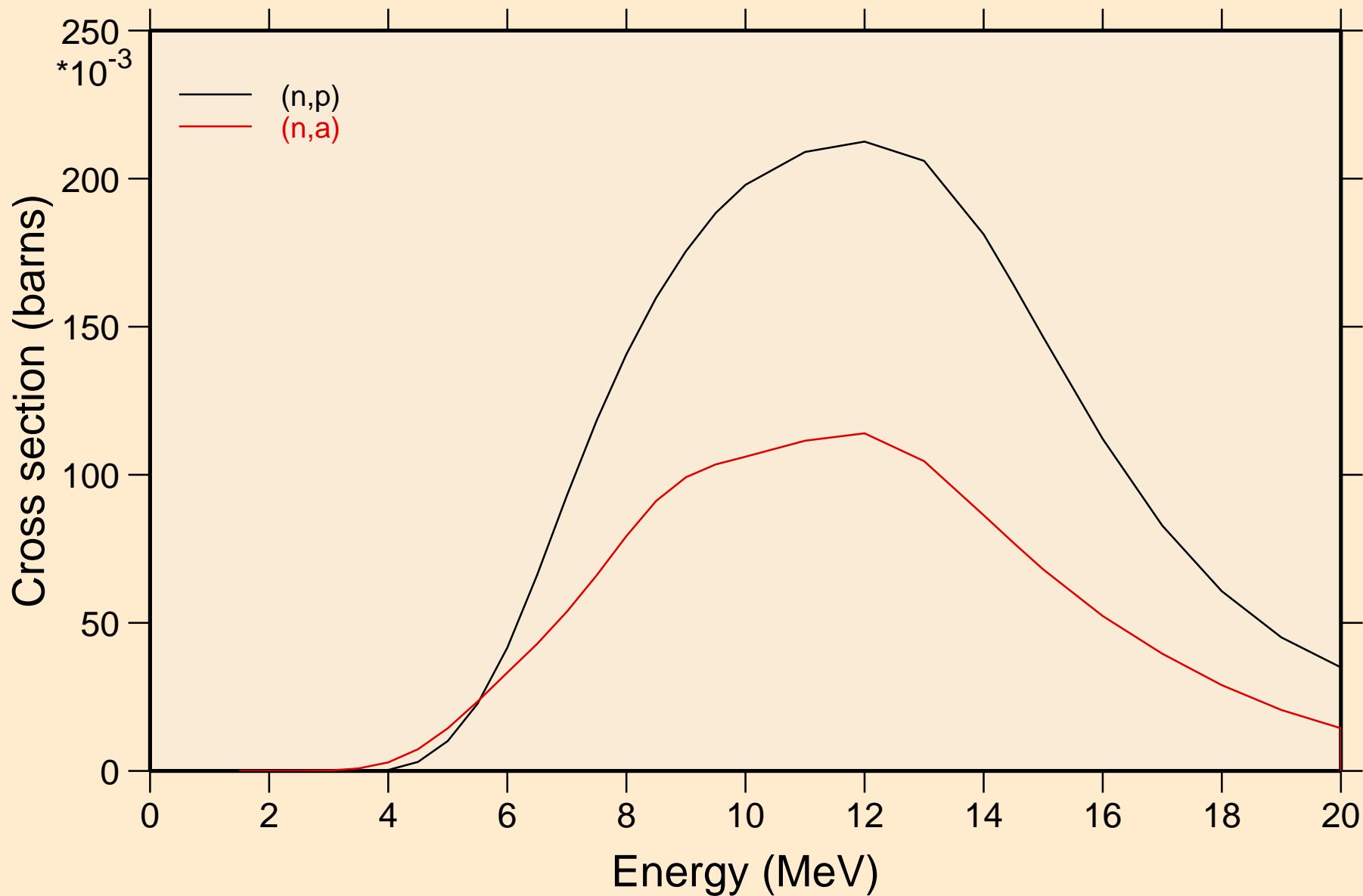

20-CA-42 FOR FENDL-3.1 FROM FENDL-3.1 WITH NJOY2012.50+  
Threshold reactions

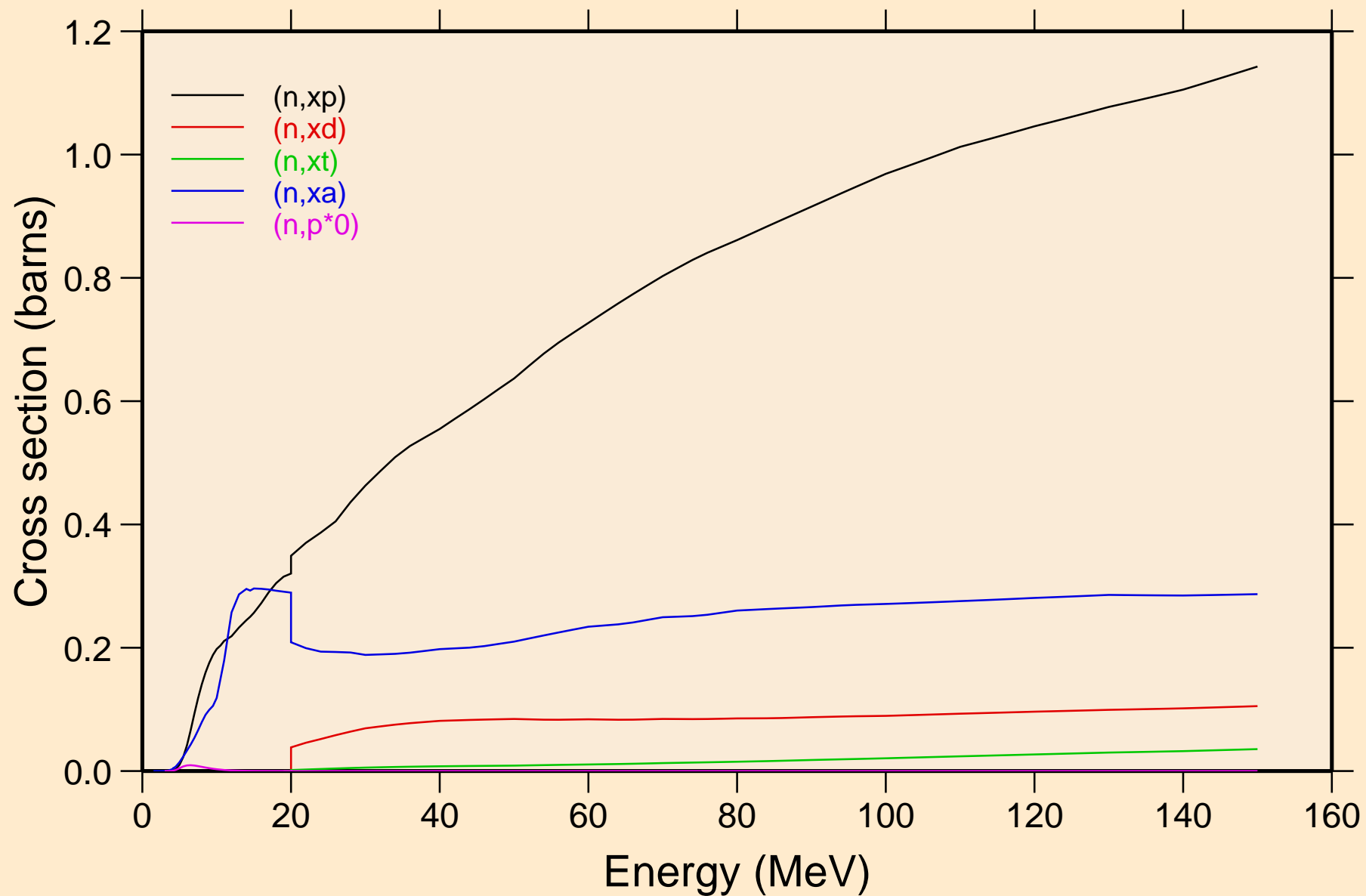

20-CA-42 FOR FENDL-3.1 FROM FENDL-3.1 WITH NJOY2012.50+  
Threshold reactions

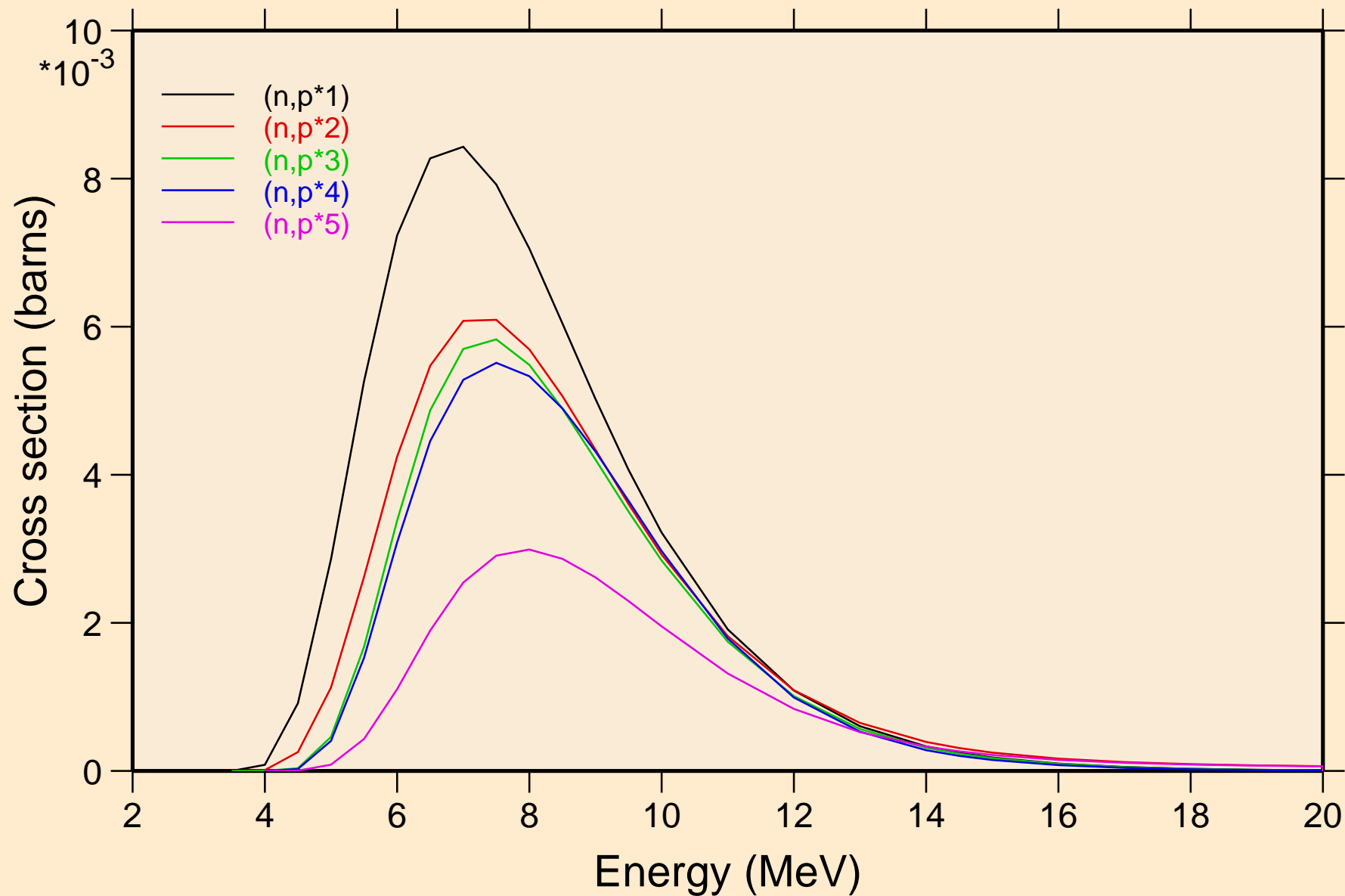

20-CA-42 FOR FENDL-3.1 FROM FENDL-3.1 WITH NJOY2012.50+  
Threshold reactions

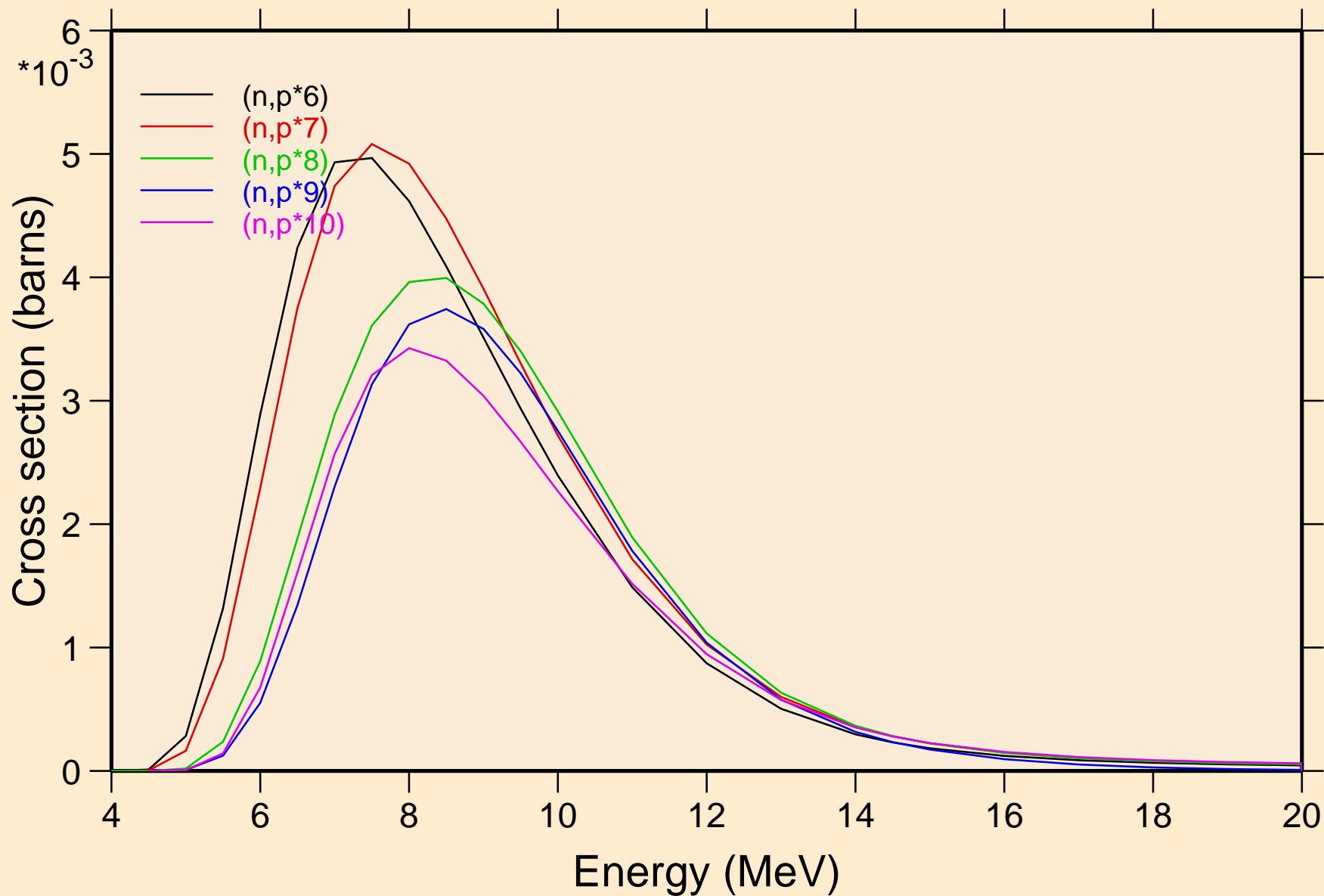

# 20-CA-42 FOR FENDL-3.1 FROM FENDL-3.1 WITH NJOY2012.50+ Threshold reactions

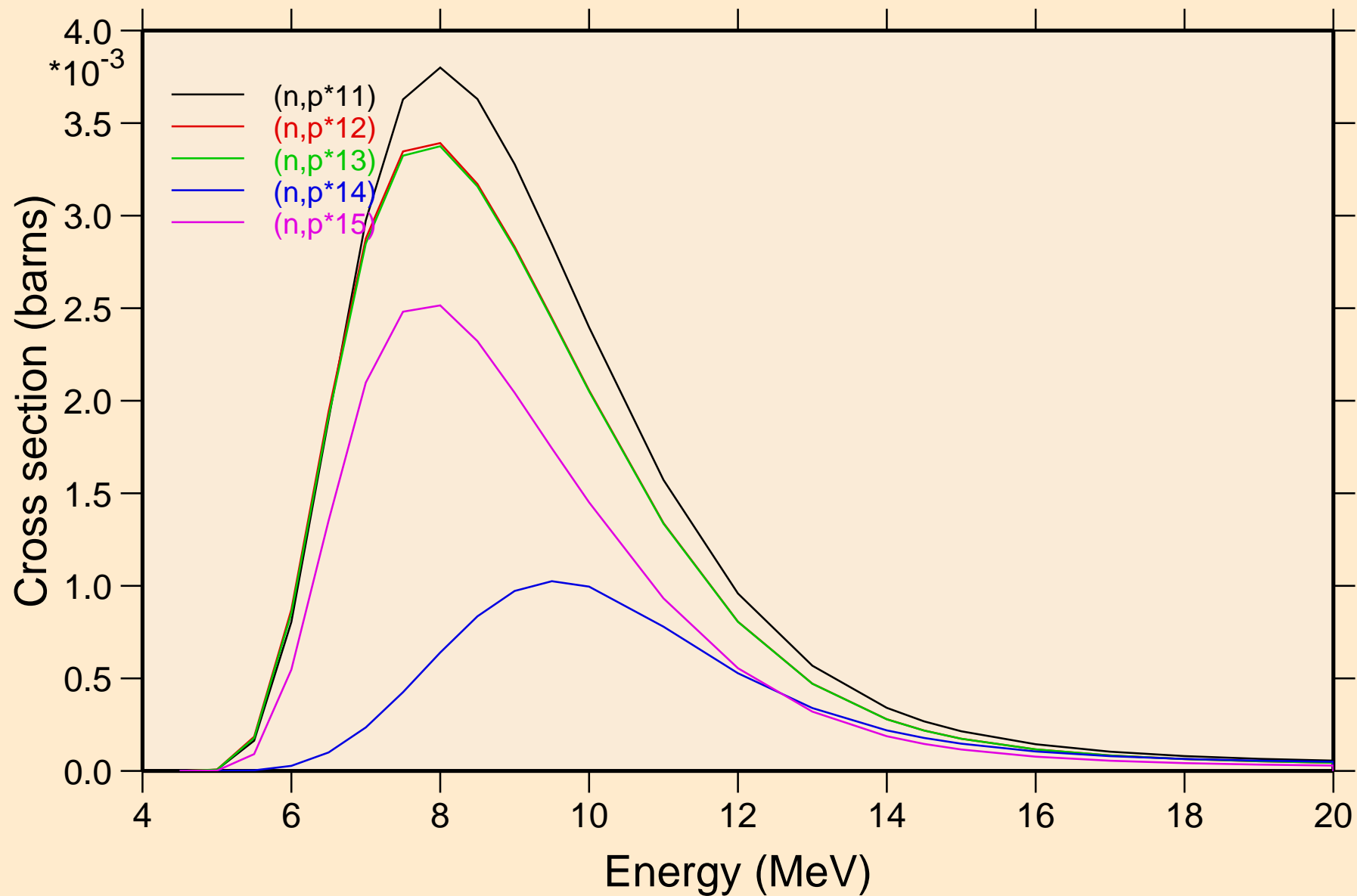

20-CA-42 FOR FENDL-3.1 FROM FENDL-3.1 WITH NJOY2012.50+  
Threshold reactions

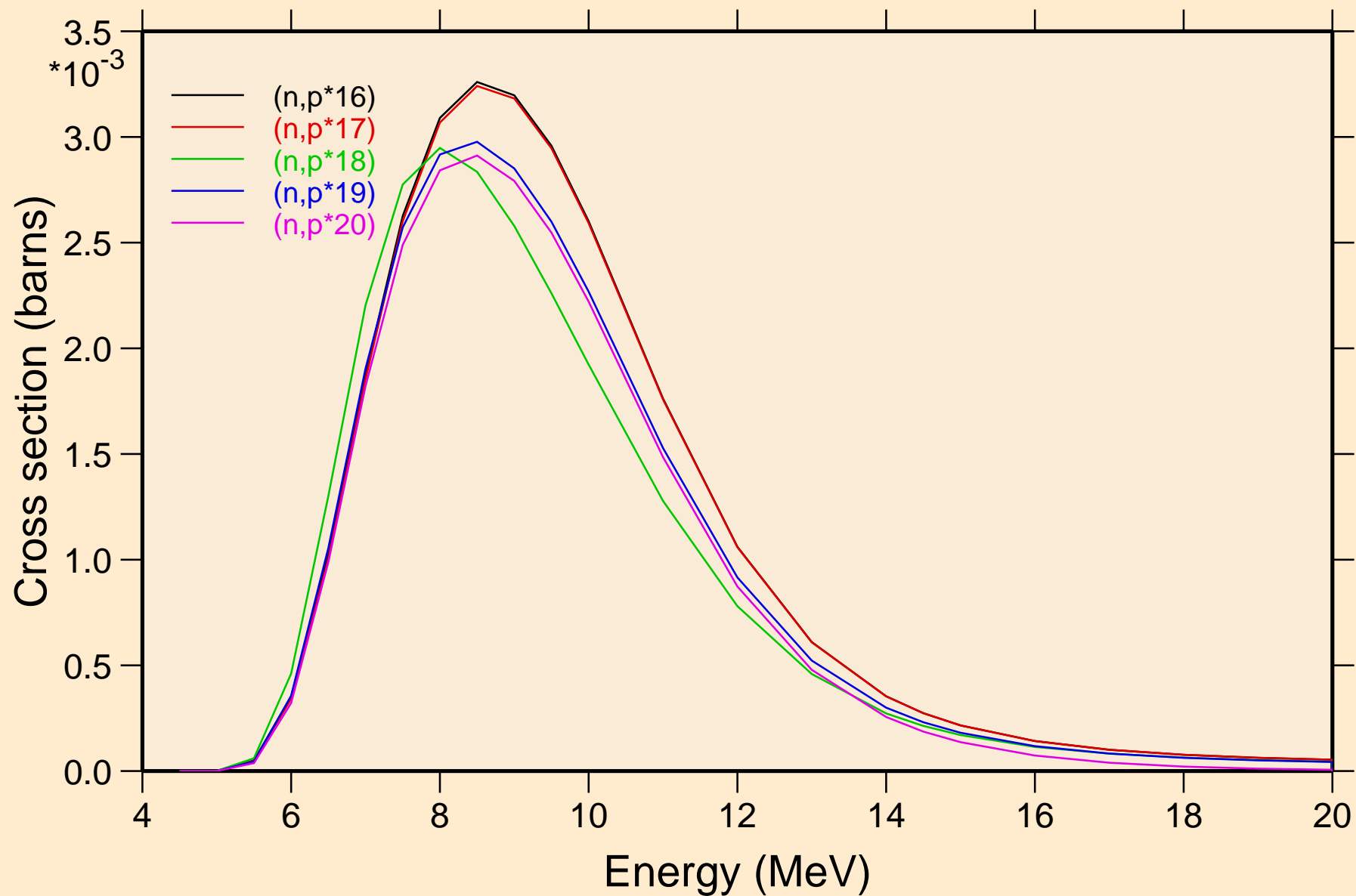

# 20-CA-42 FOR FENDL-3.1 FROM FENDL-3.1 WITH NJOY2012.50+

## Threshold reactions

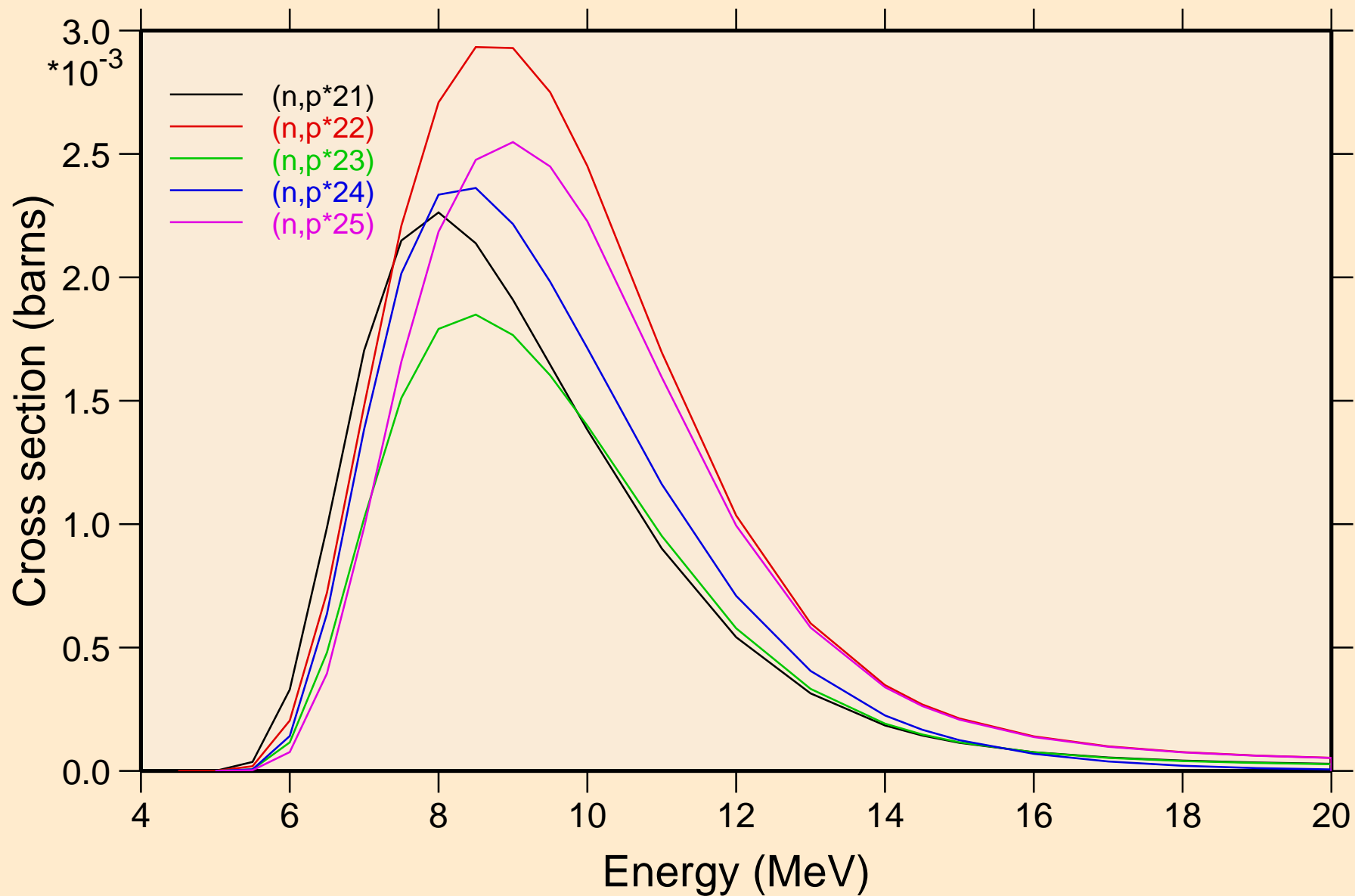



20-CA-42 FOR FENDL-3.1 FROM FENDL-3.1 WITH NJOY2012.50+  
Threshold reactions

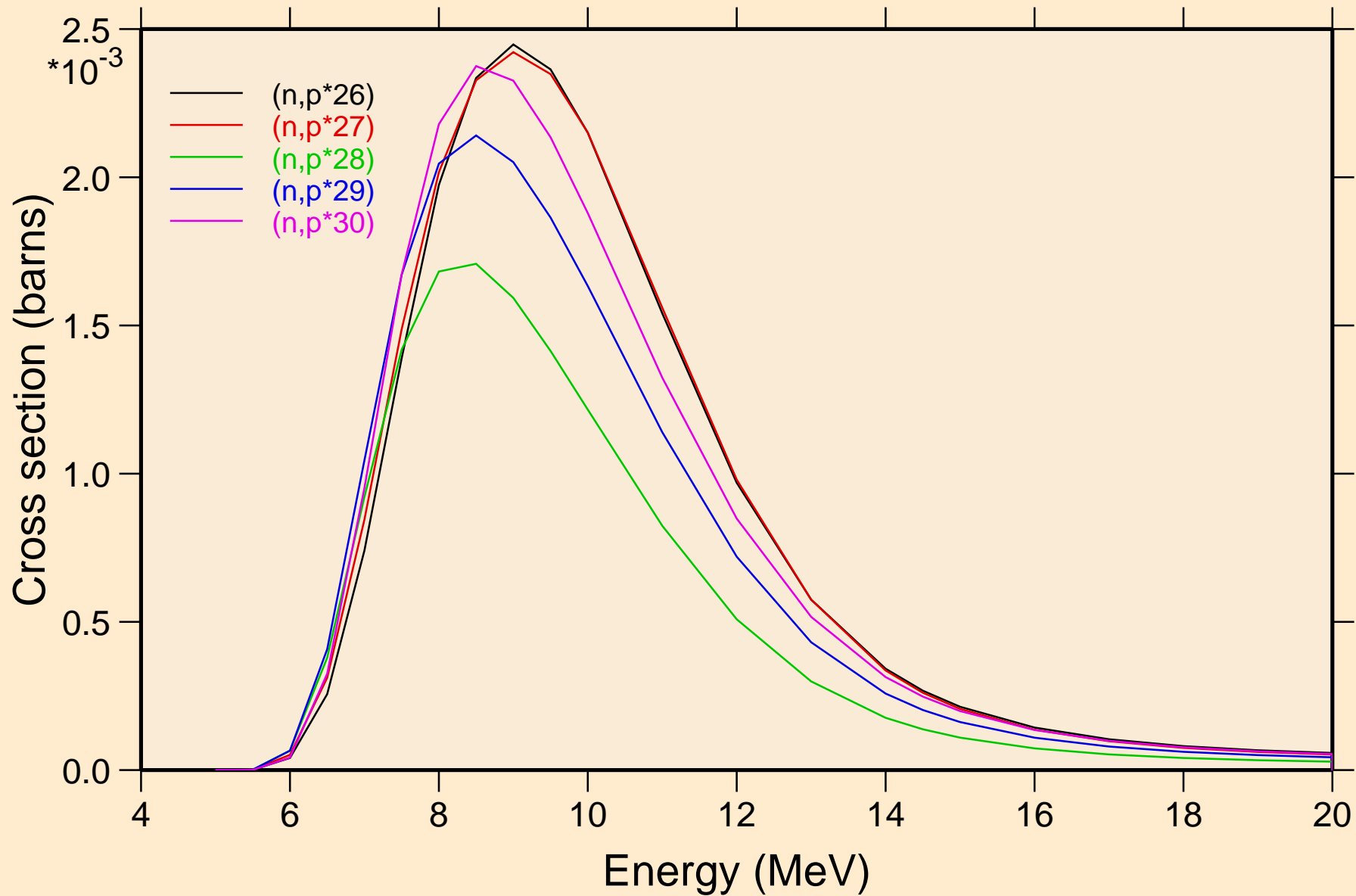

20-CA-42 FOR FENDL-3.1 FROM FENDL-3.1 WITH NJOY2012.50+  
Threshold reactions

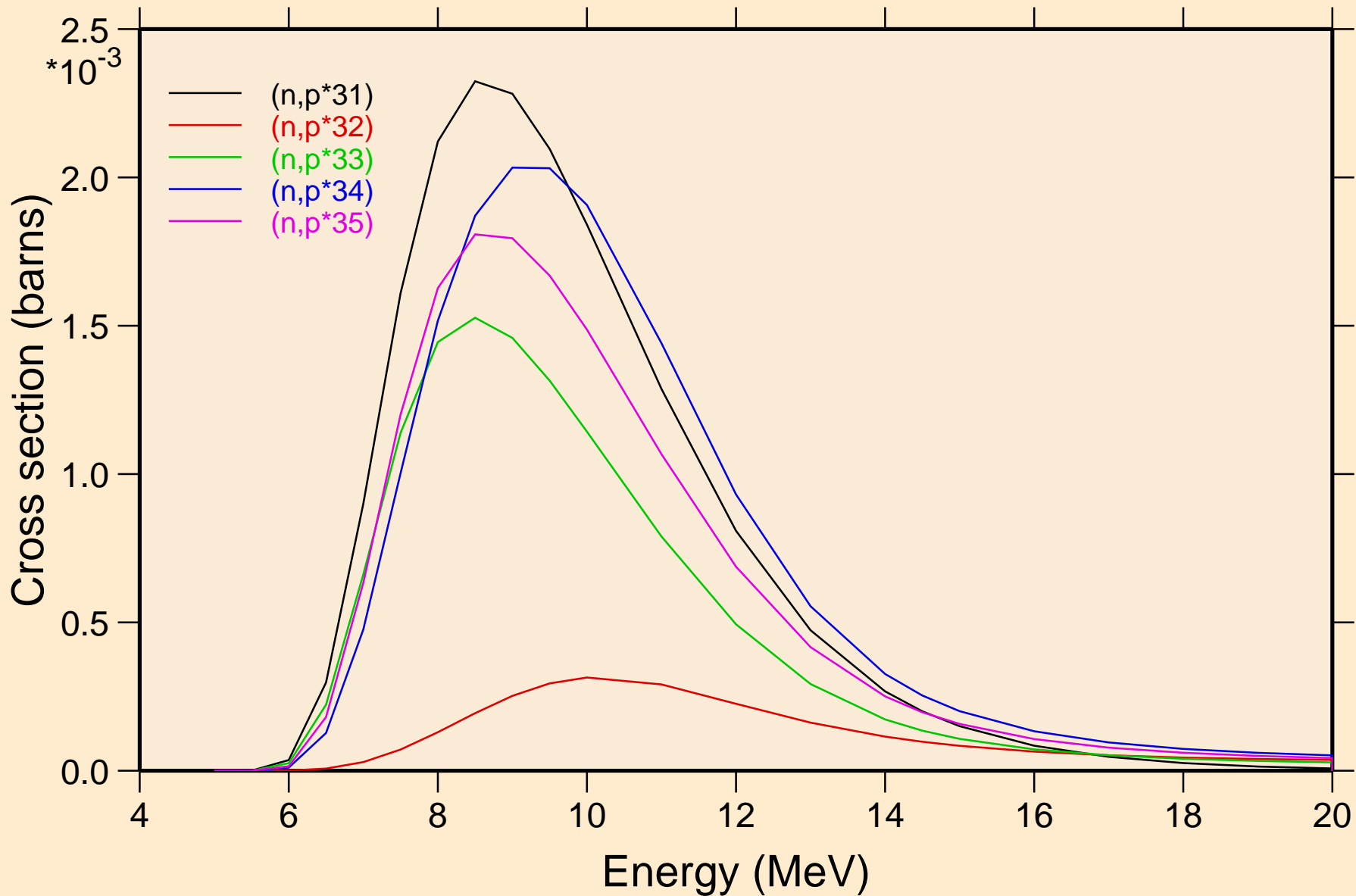

# 20-CA-42 FOR FENDL-3.1 FROM FENDL-3.1 WITH NJOY2012.50+ Threshold reactions

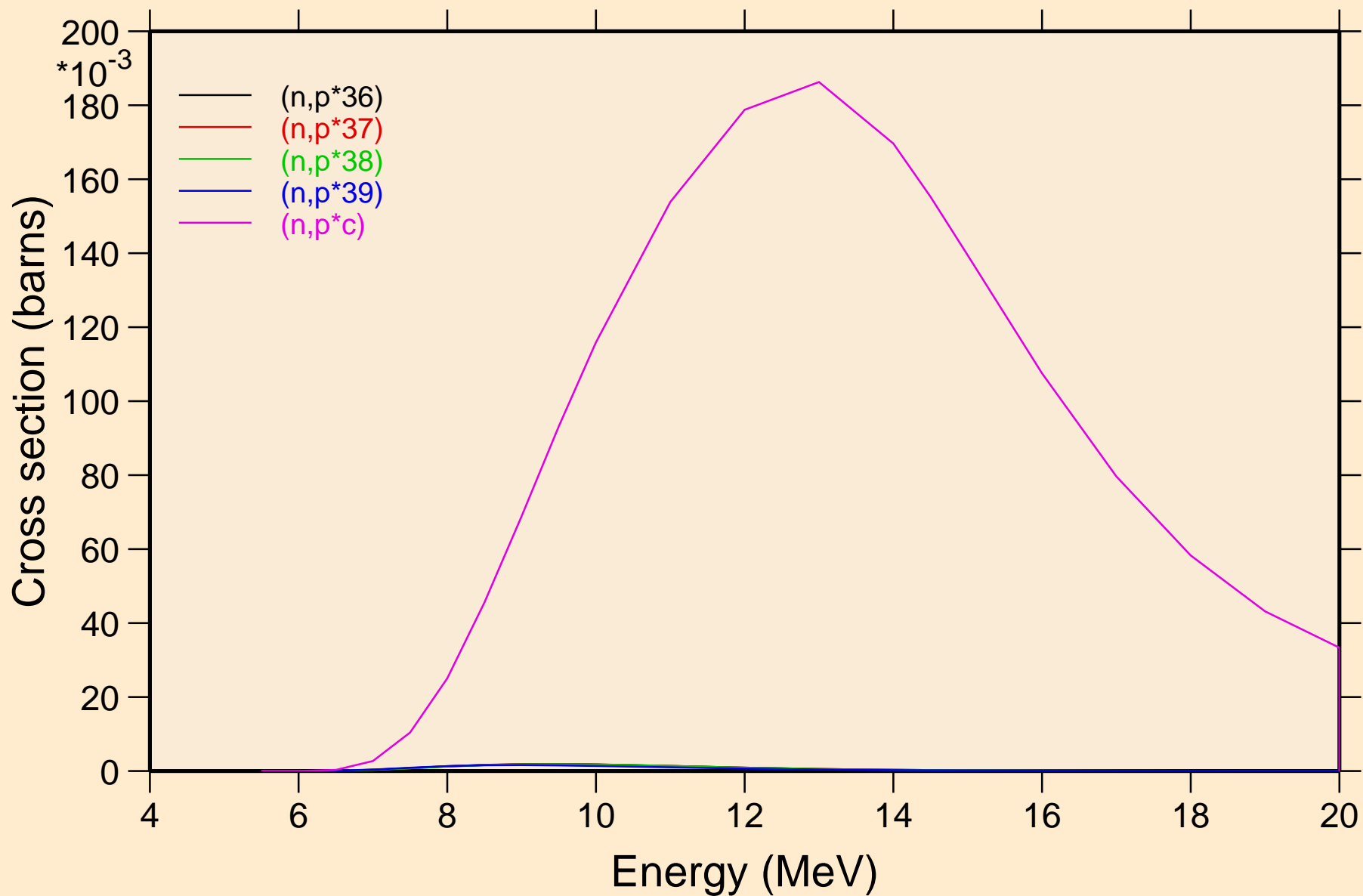

20-CA-42 FOR FENDL-3.1 FROM FENDL-3.1 WITH NJOY2012.50+  
Threshold reactions

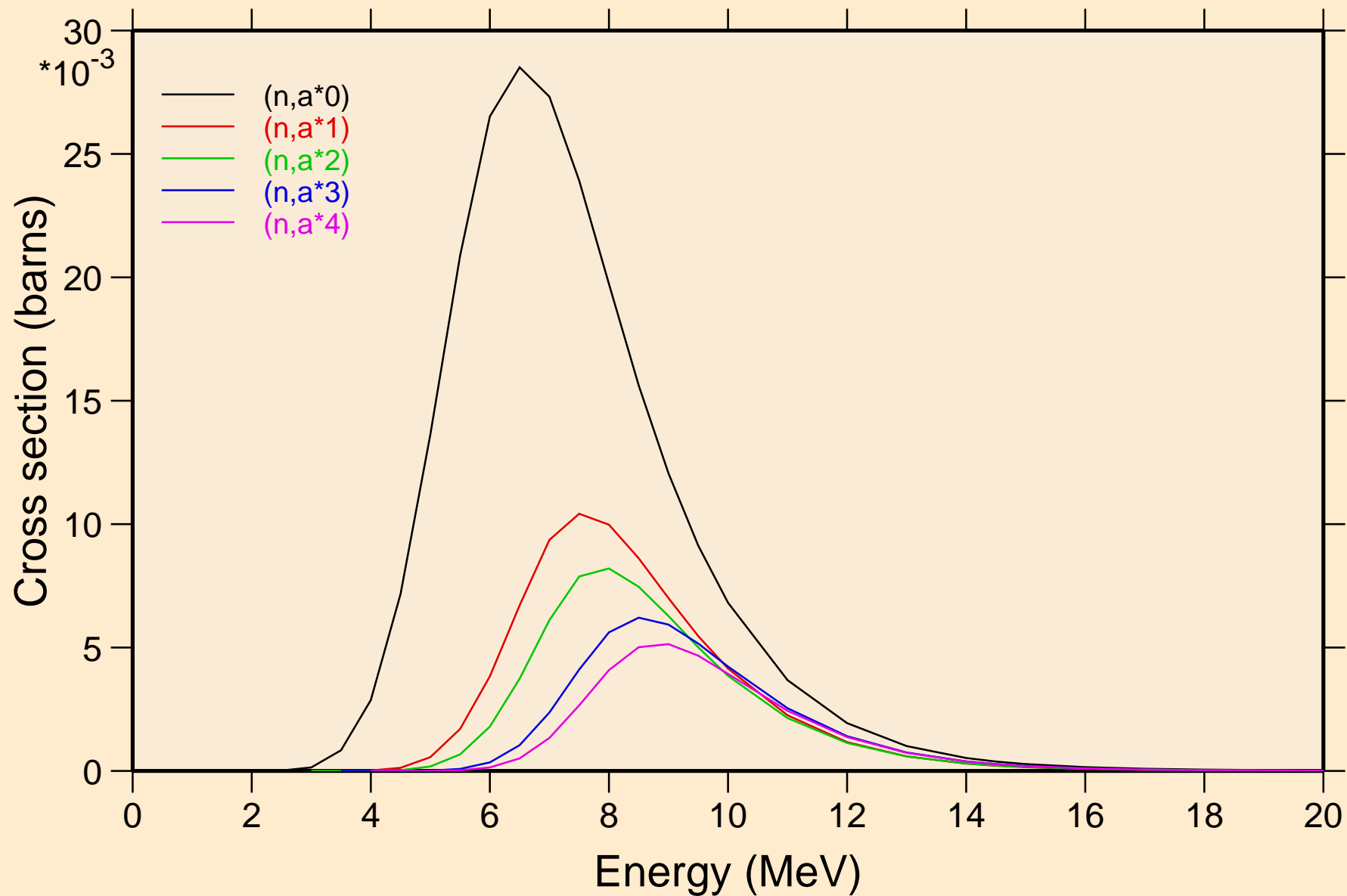

# 20-CA-42 FOR FENDL-3.1 FROM FENDL-3.1 WITH NJOY2012.50+

## Threshold reactions

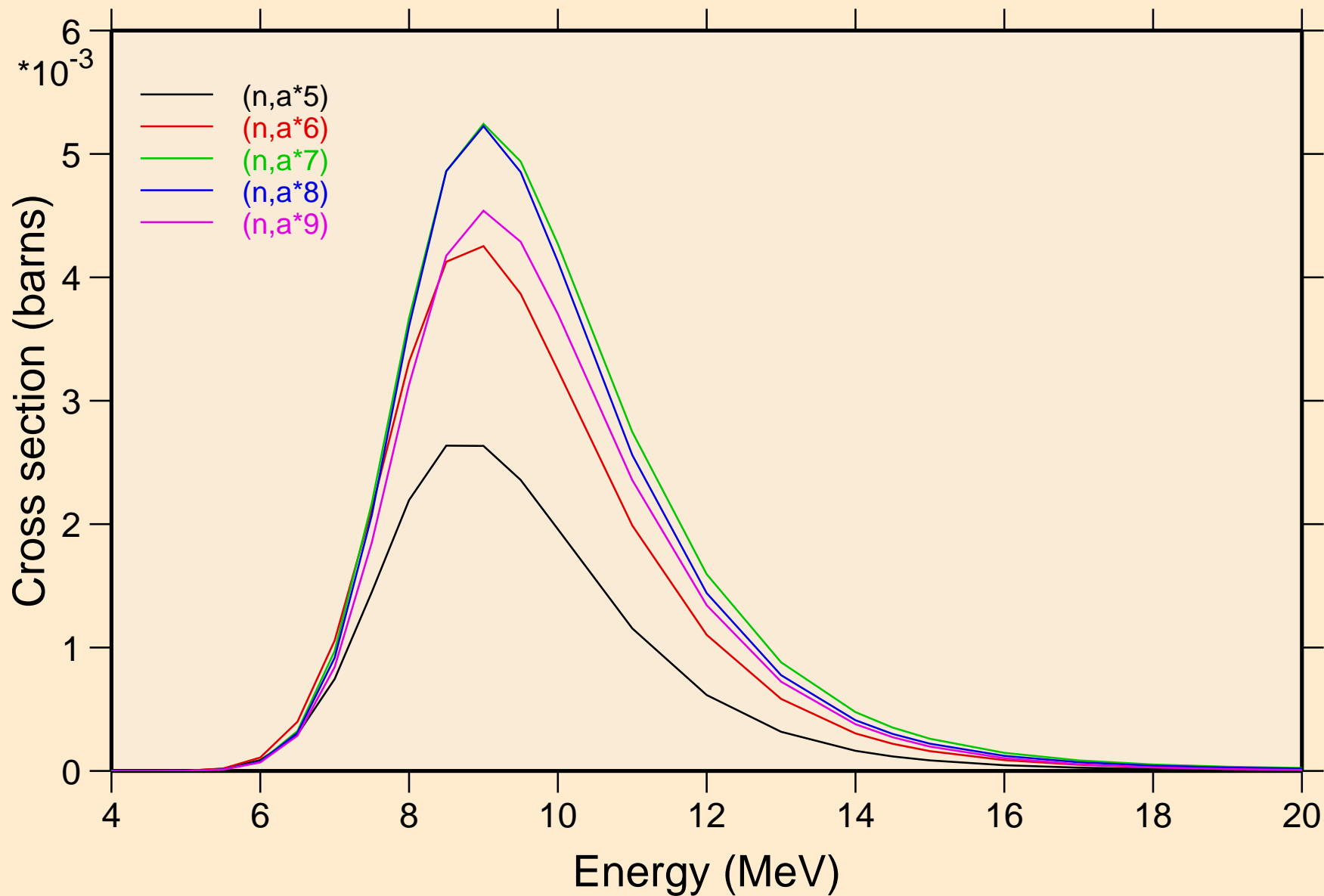

20-CA-42 FOR FENDL-3.1 FROM FENDL-3.1 WITH NJOY2012.50+  
Threshold reactions

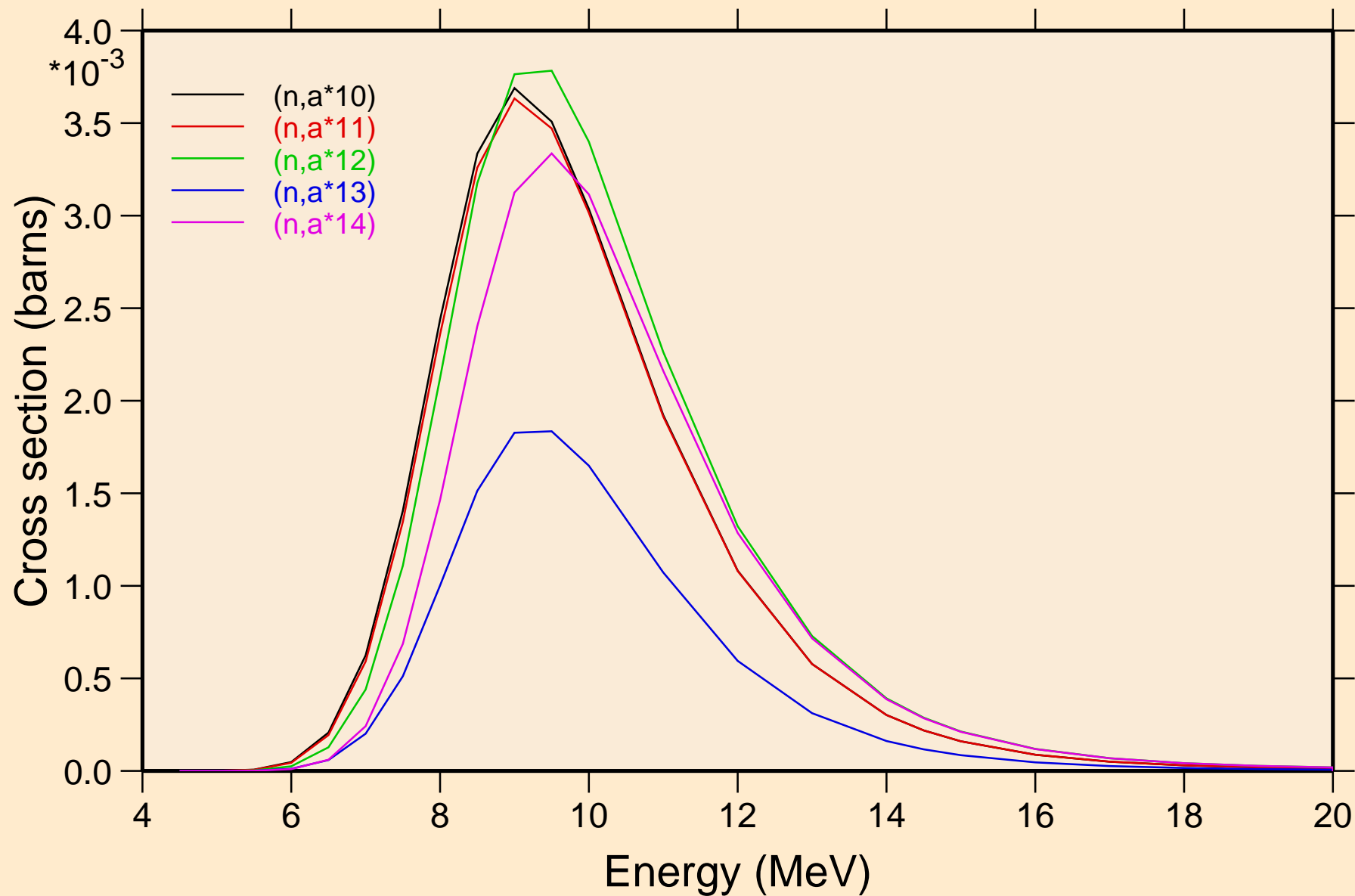

20-CA-42 FOR FENDL-3.1 FROM FENDL-3.1 WITH NJOY2012.50+  
Threshold reactions

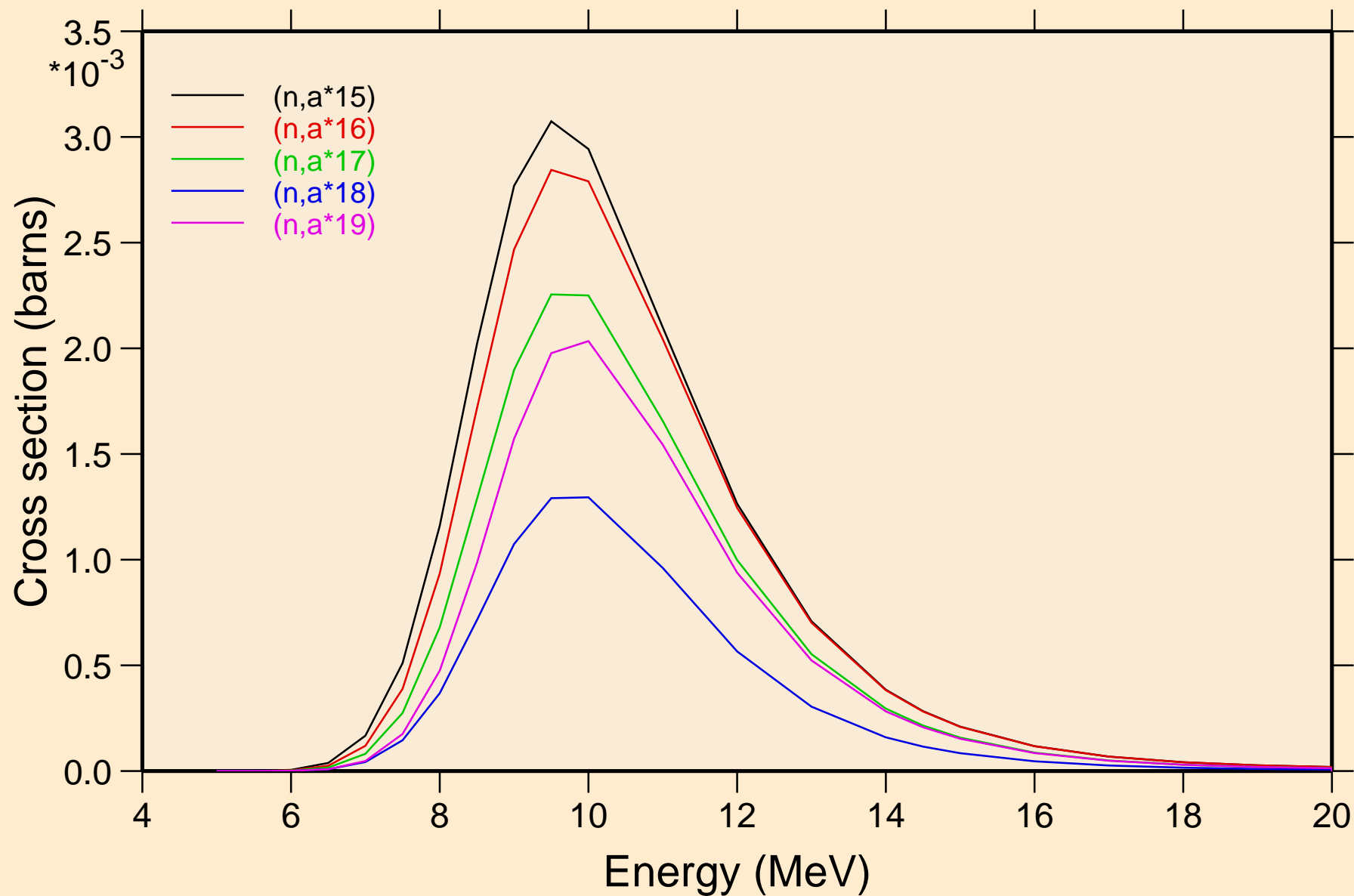

20-CA-42 FOR FENDL-3.1 FROM FENDL-3.1 WITH NJOY2012.50+  
Threshold reactions

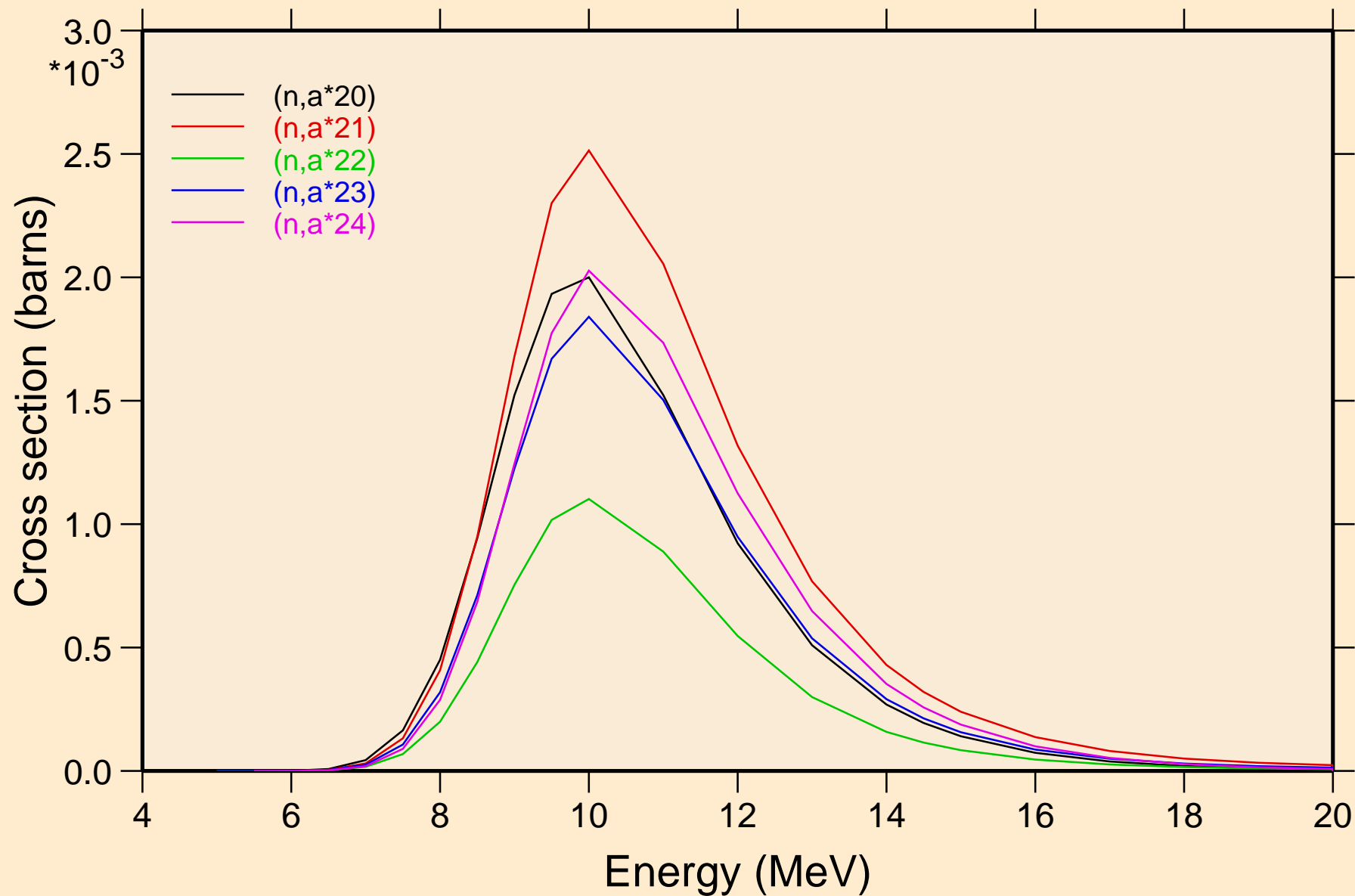



20-CA-42 FOR FENDL-3.1 FROM FENDL-3.1 WITH NJOY2012.50+  
Threshold reactions

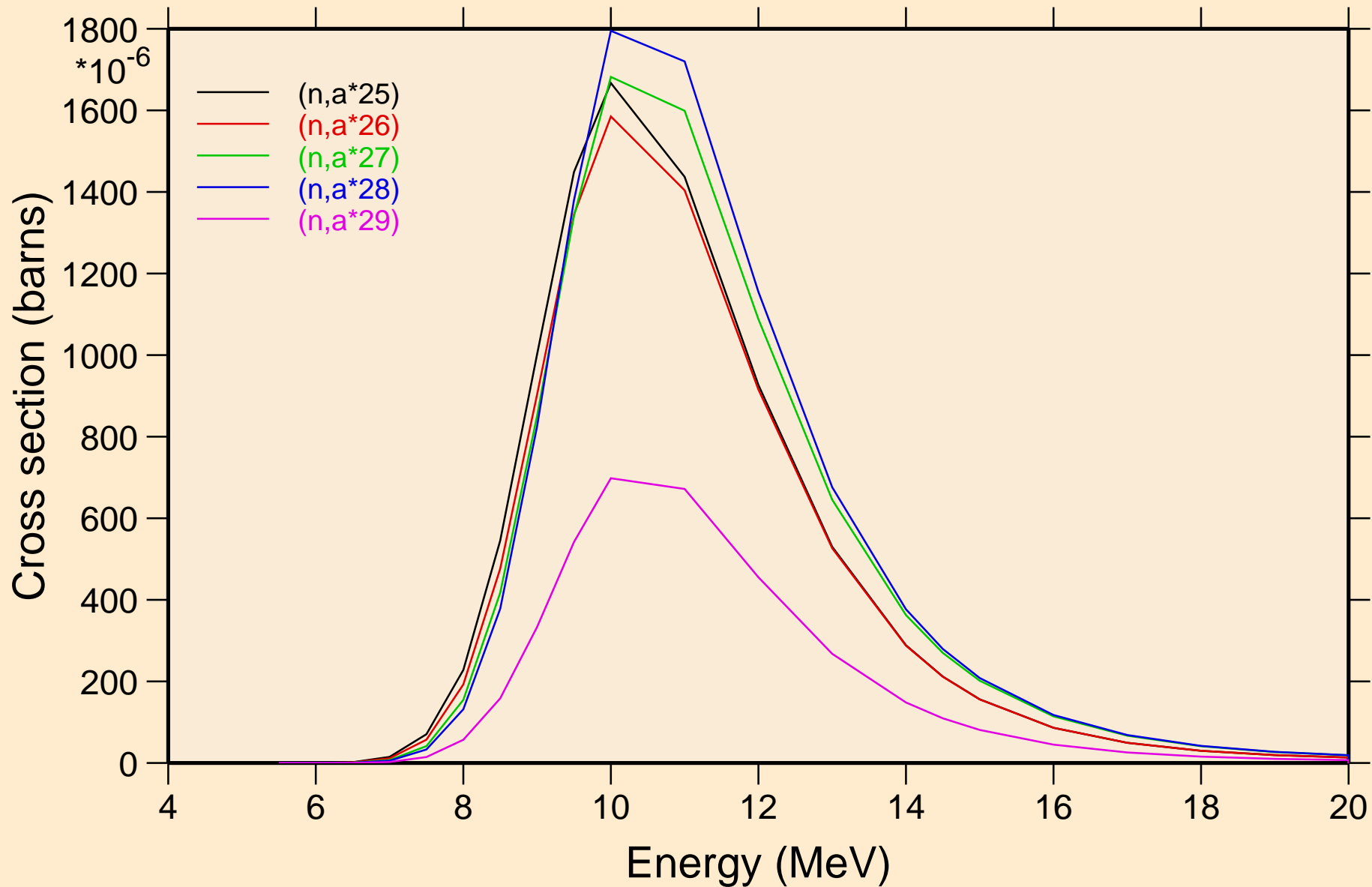

20-CA-42 FOR FENDL-3.1 FROM FENDL-3.1 WITH NJOY2012.50+  
Threshold reactions

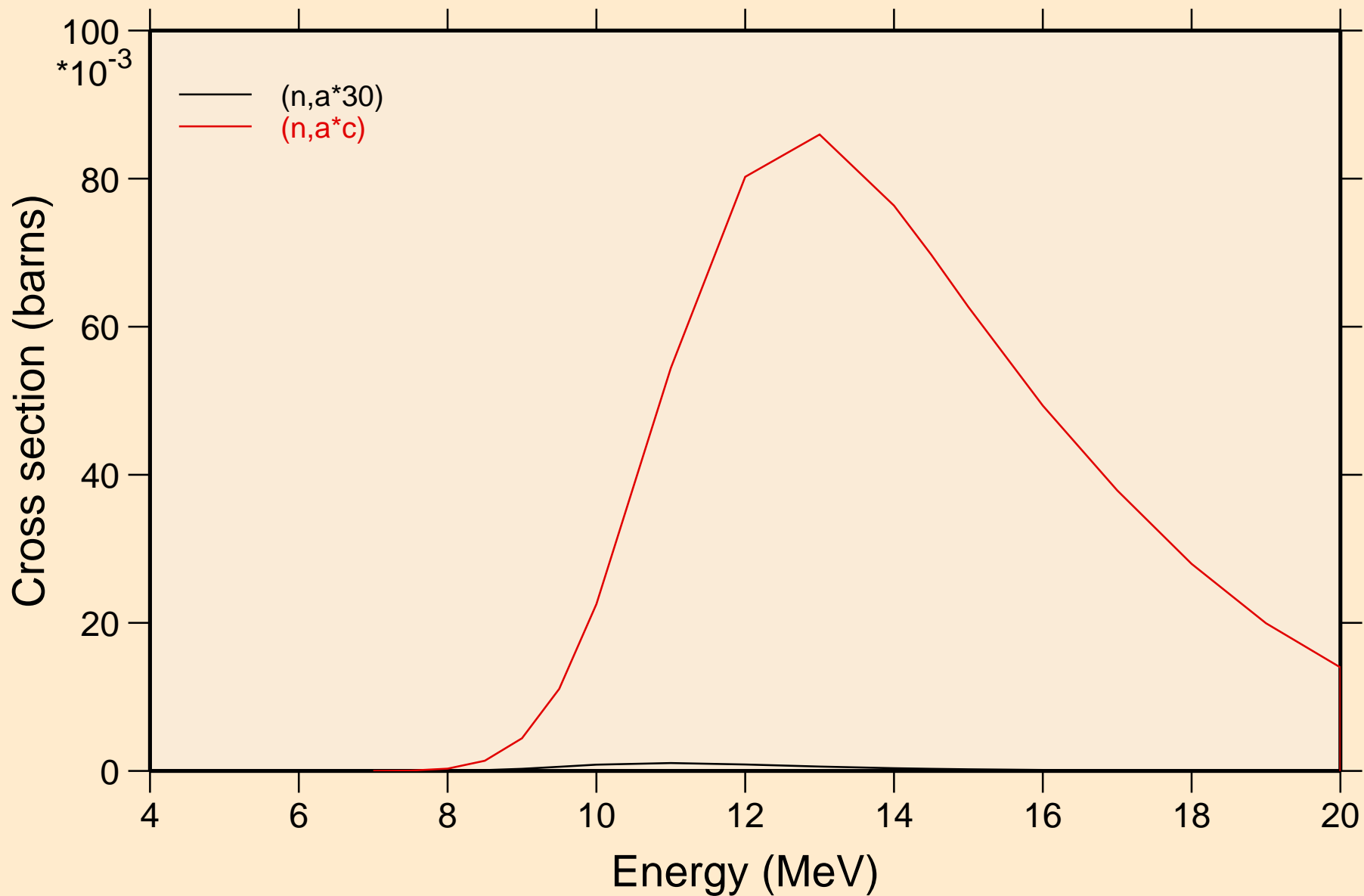

20-CA-42 FOR FENDL-3.1 FROM FENDL-3.1 WITH NJOY2012.50+  
angular distribution for elastic

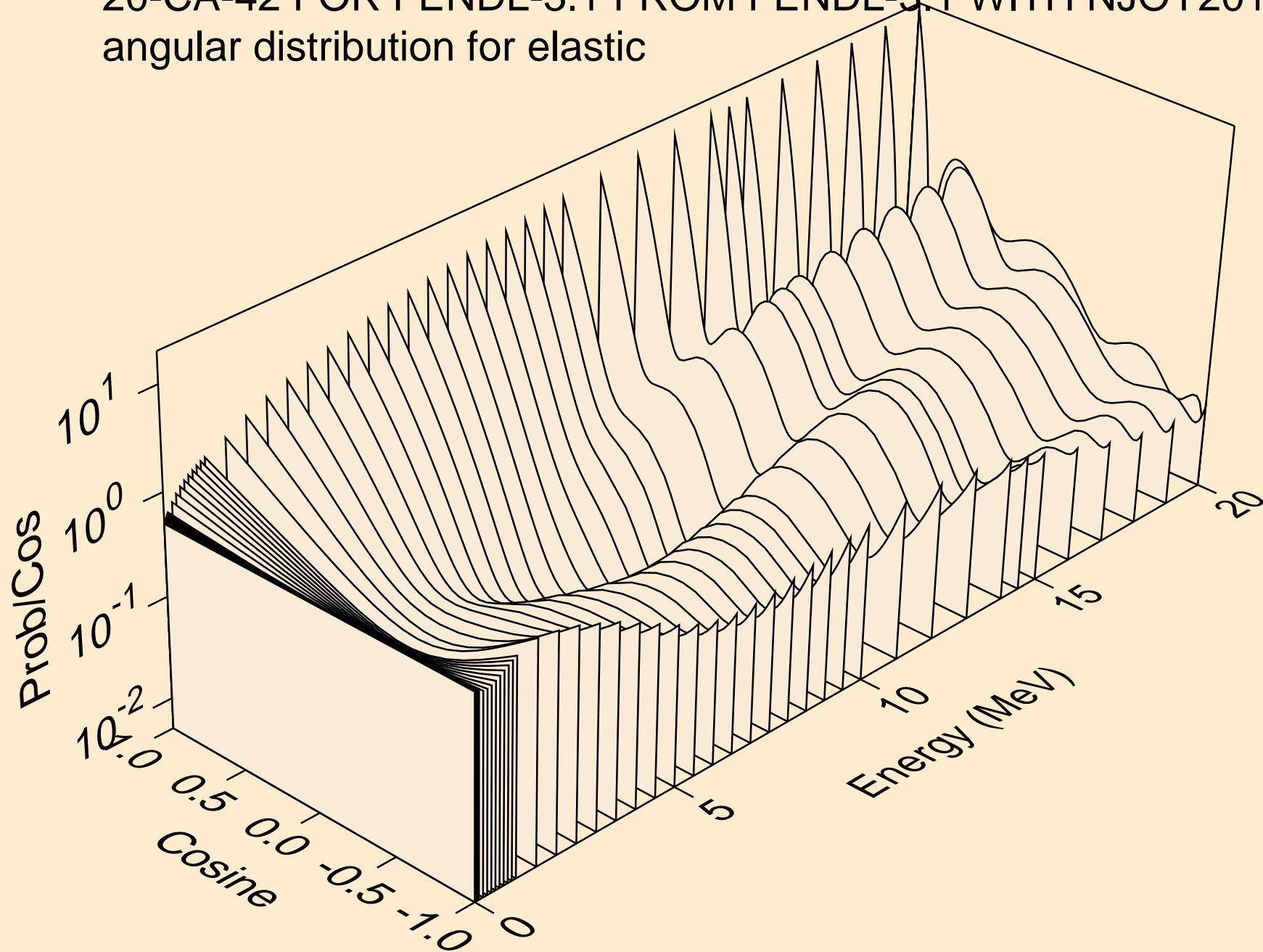

20-CA-42 FOR FENDL-3.1 FROM FENDL-3.1 WITH NJOY2012.50+  
angular distribution for elastic

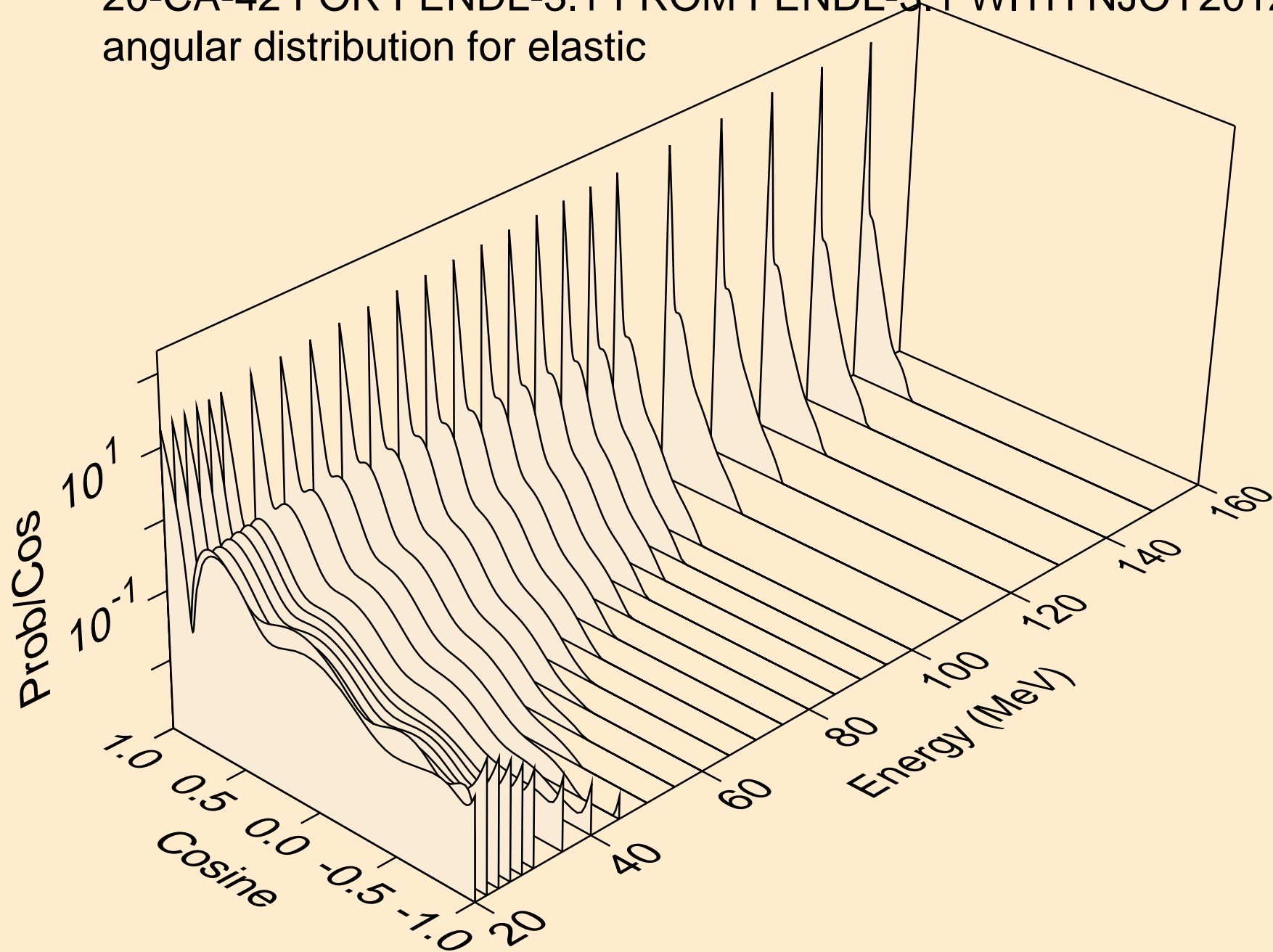

20-CA-42 FOR FENDL-3.1 FROM FENDL-3.1 WITH NJOY2012.50+  
angular distribution for (n,n\*1)

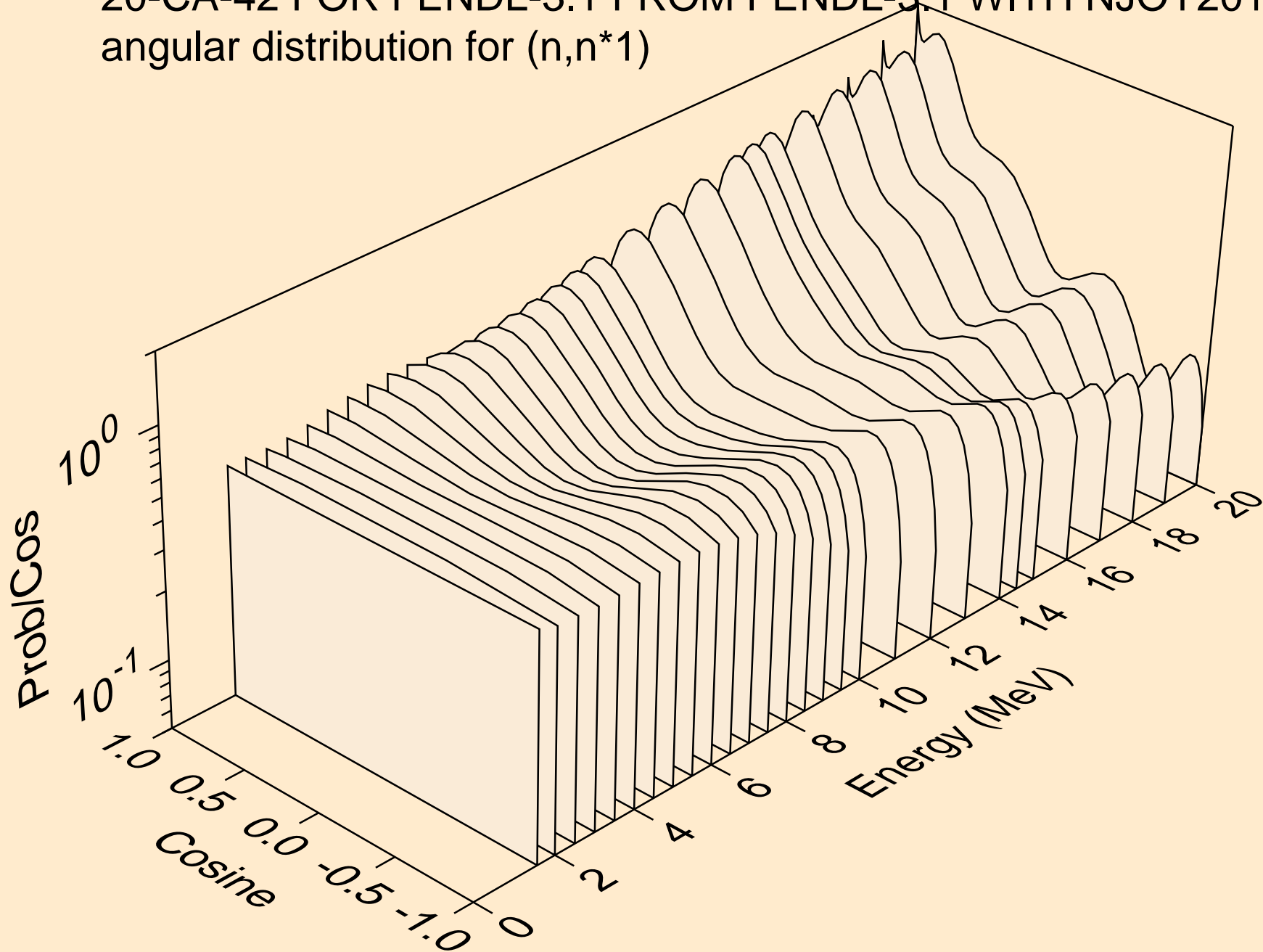

20-CA-42 FOR FENDL-3.1 FROM FENDL-3.1 WITH NJOY2012.50+  
angular distribution for (n,n\*2)

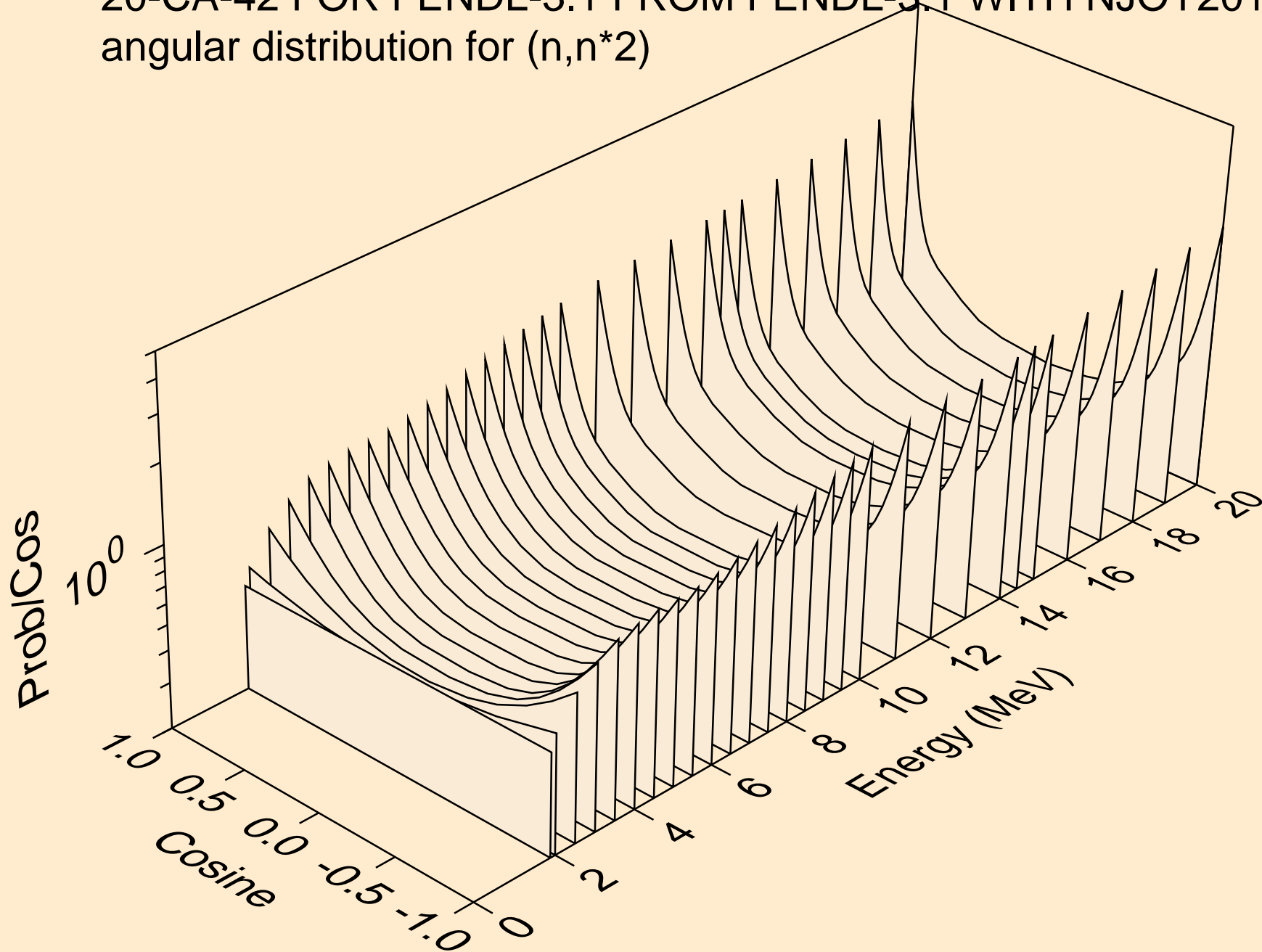

20-CA-42 FOR FENDL-3.1 FROM FENDL-3.1 WITH NJOY2012.50+  
angular distribution for (n,n\*3)

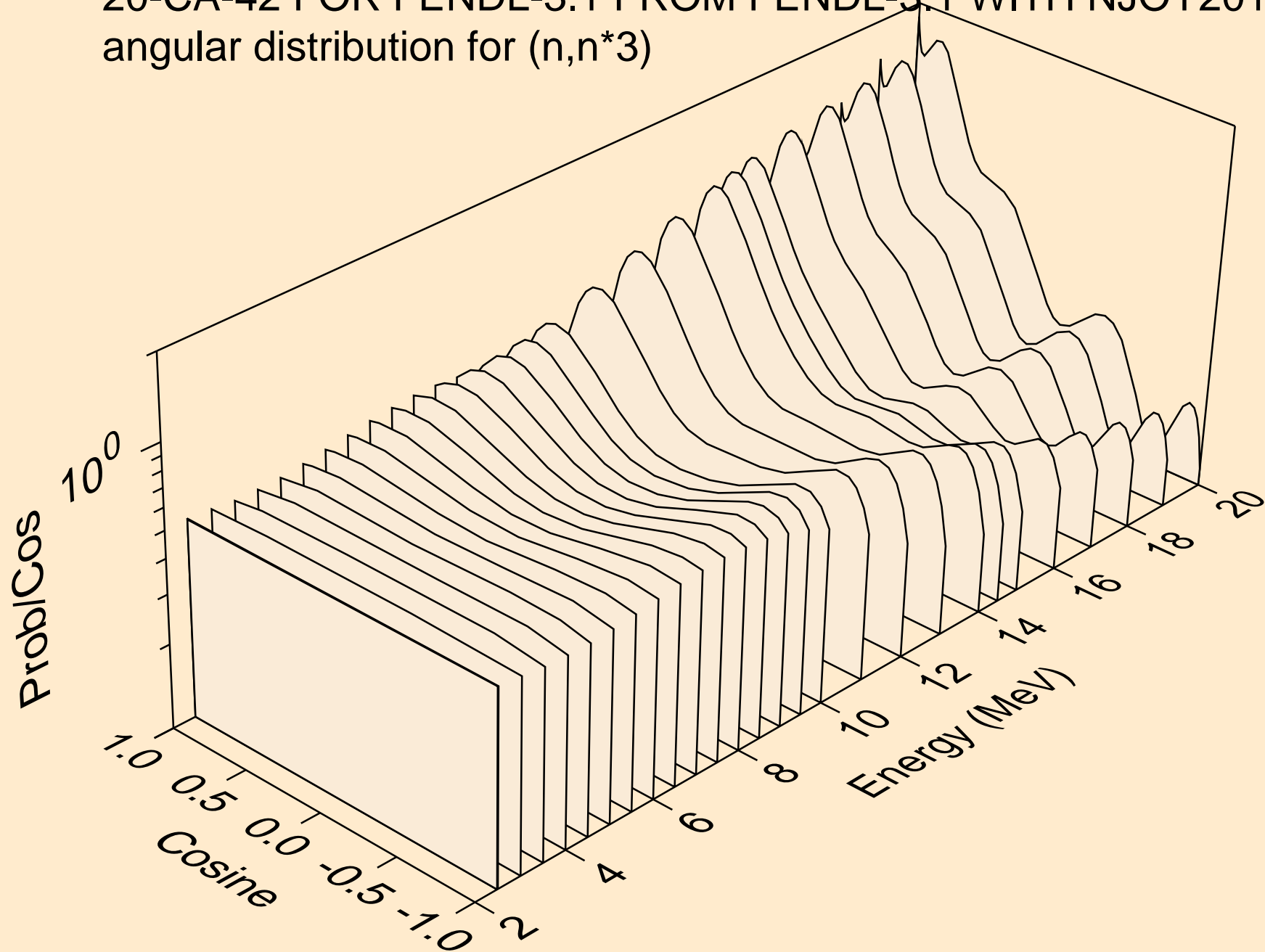

20-CA-42 FOR FENDL-3.1 FROM FENDL-3.1 WITH NJOY2012.50+  
angular distribution for (n,n\*4)

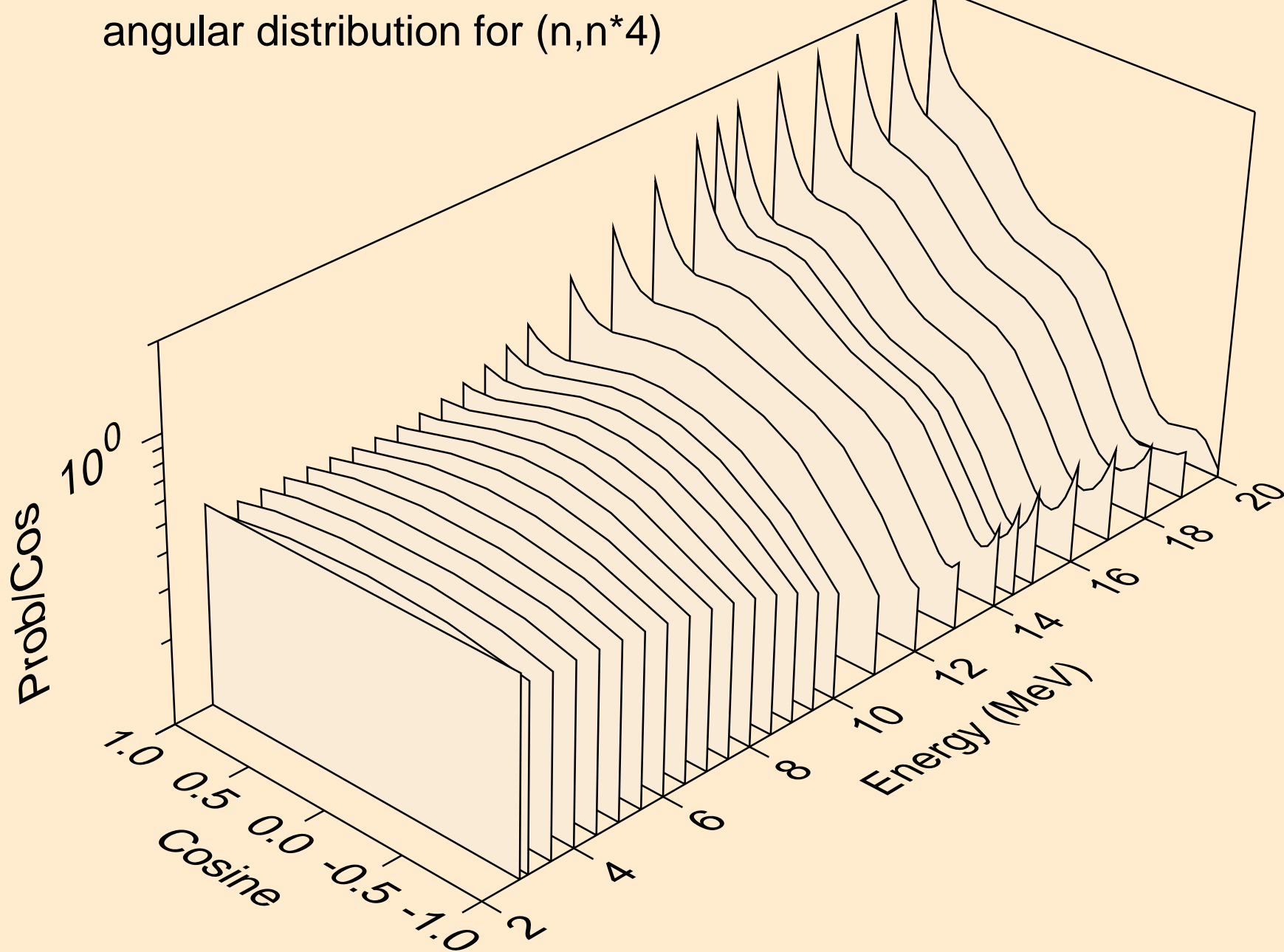



20-CA-42 FOR FENDL-3.1 FROM FENDL-3.1 WITH NJOY2012.50+  
angular distribution for (n,n\*5)

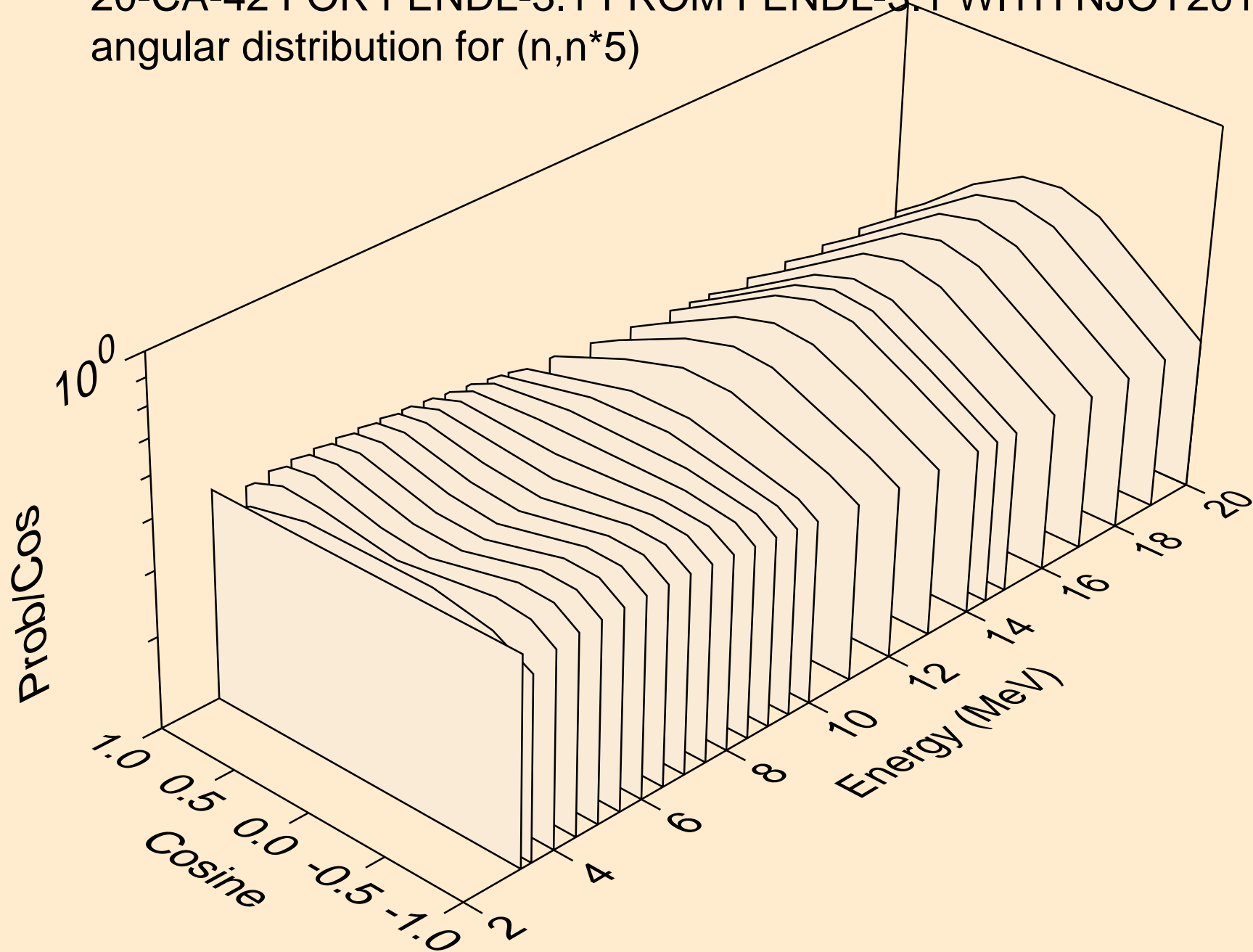

20-CA-42 FOR FENDL-3.1 FROM FENDL-3.1 WITH NJOY2012.50+  
angular distribution for (n,n\*6)

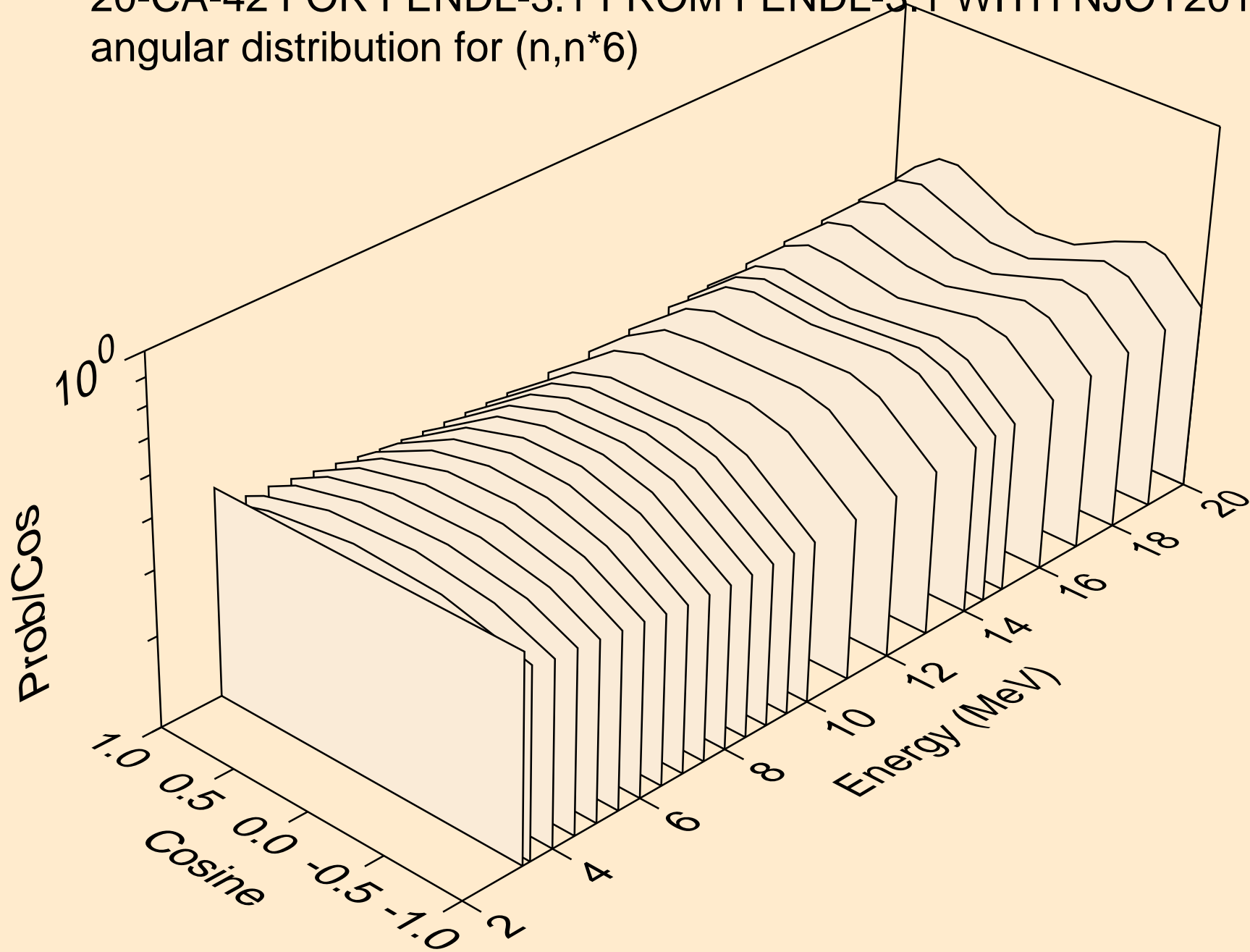

20-CA-42 FOR FENDL-3.1 FROM FENDL-3.1 WITH NJOY2012.50+  
angular distribution for (n,n\*7)

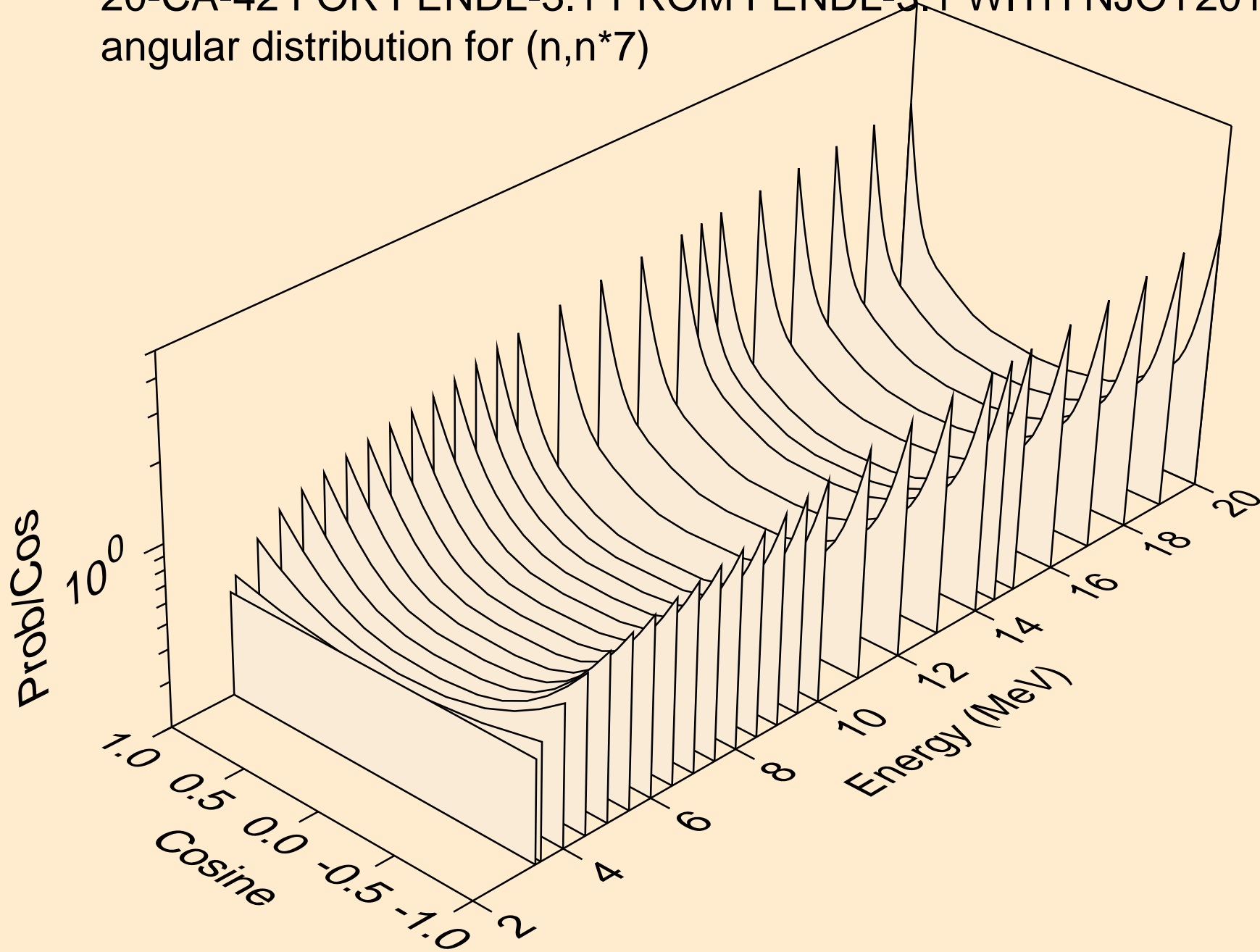

20-CA-42 FOR FENDL-3.1 FROM FENDL-3.1 WITH NJOY2012.50+  
angular distribution for (n,n\*8)

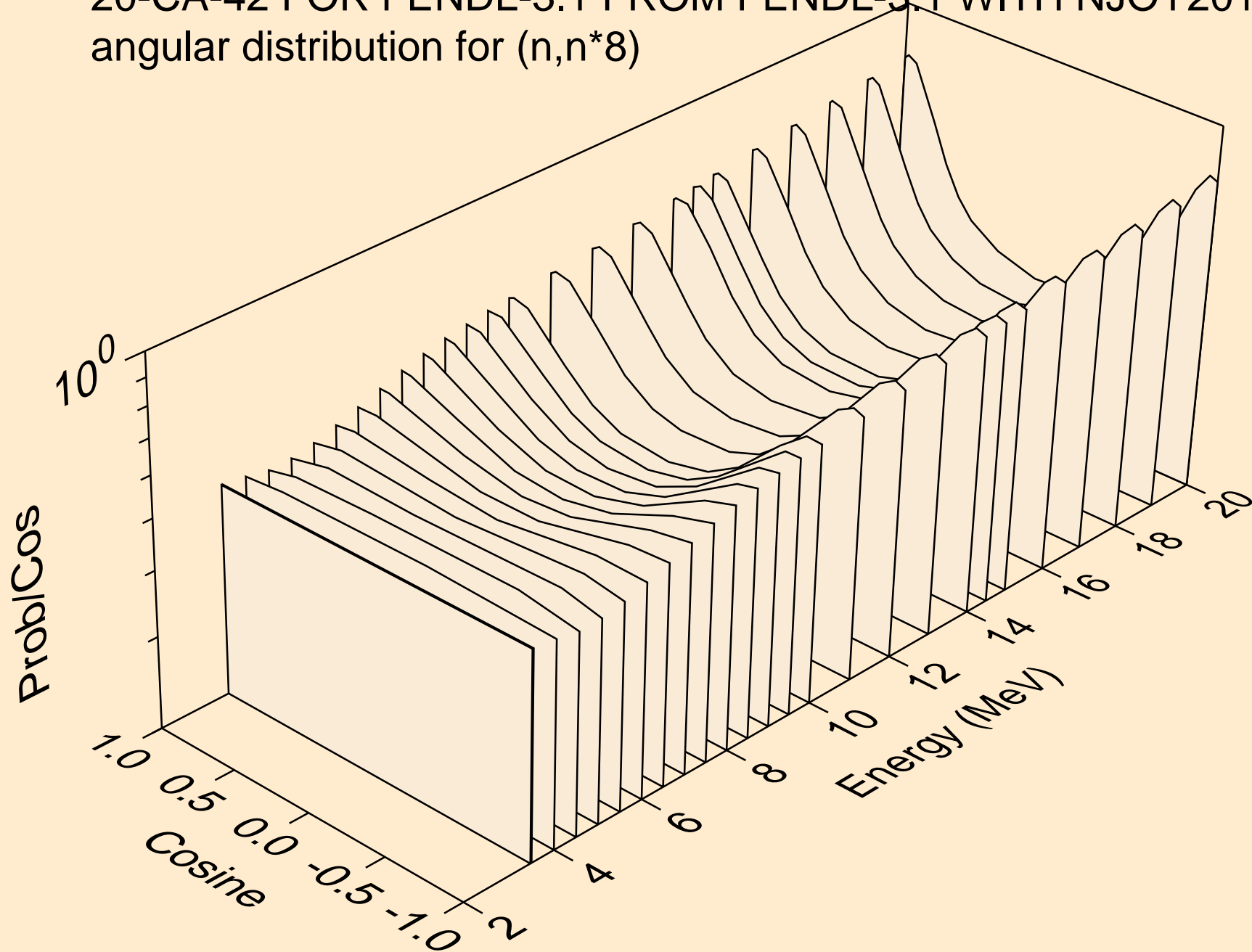

20-CA-42 FOR FENDL-3.1 FROM FENDL-3.1 WITH NJOY2012.50+  
angular distribution for (n,n\*9)

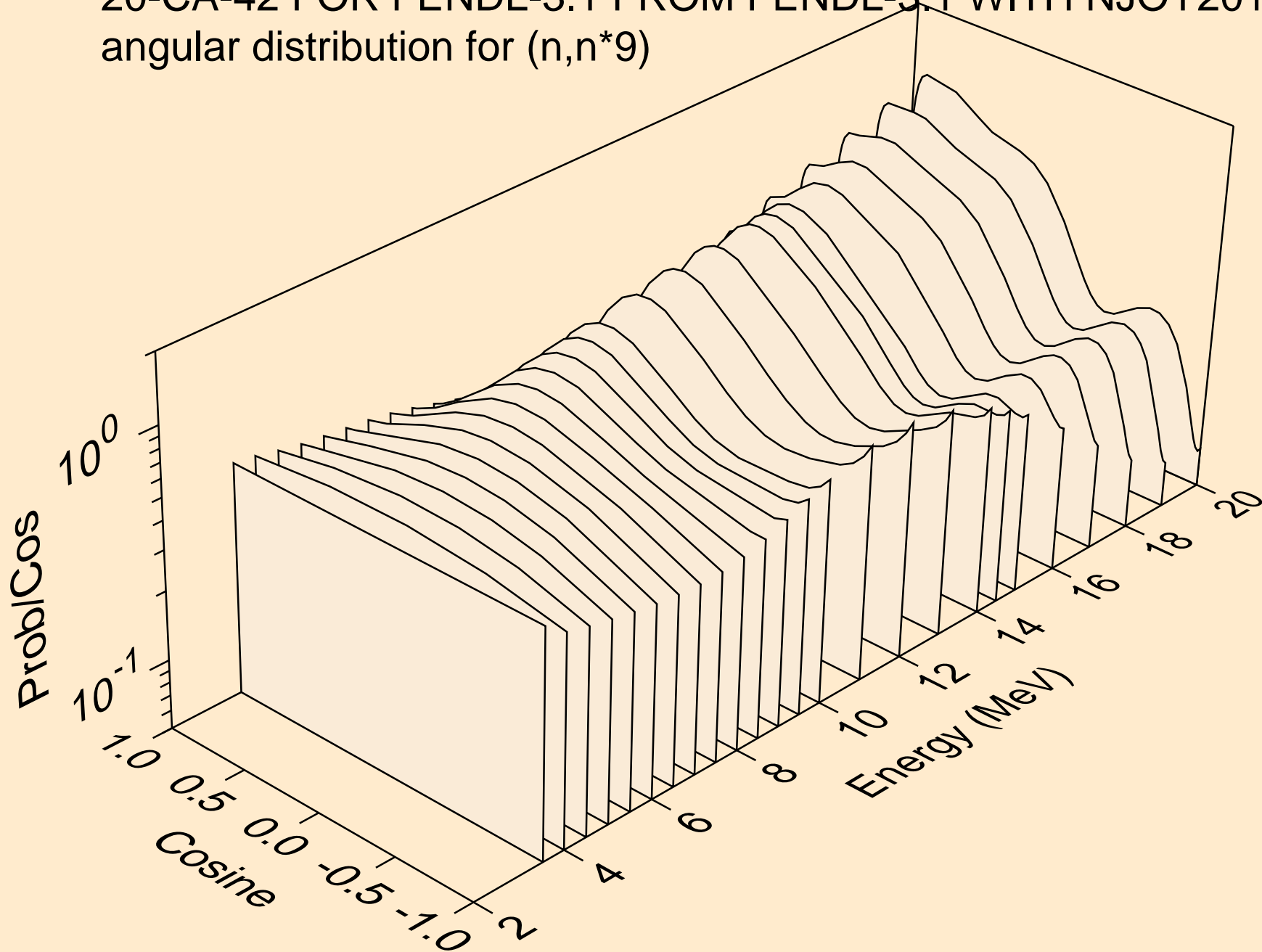

20-CA-42 FOR FENDL-3.1 FROM FENDL-3.1 WITH NJOY2012.50+  
angular distribution for (n,n\*10)

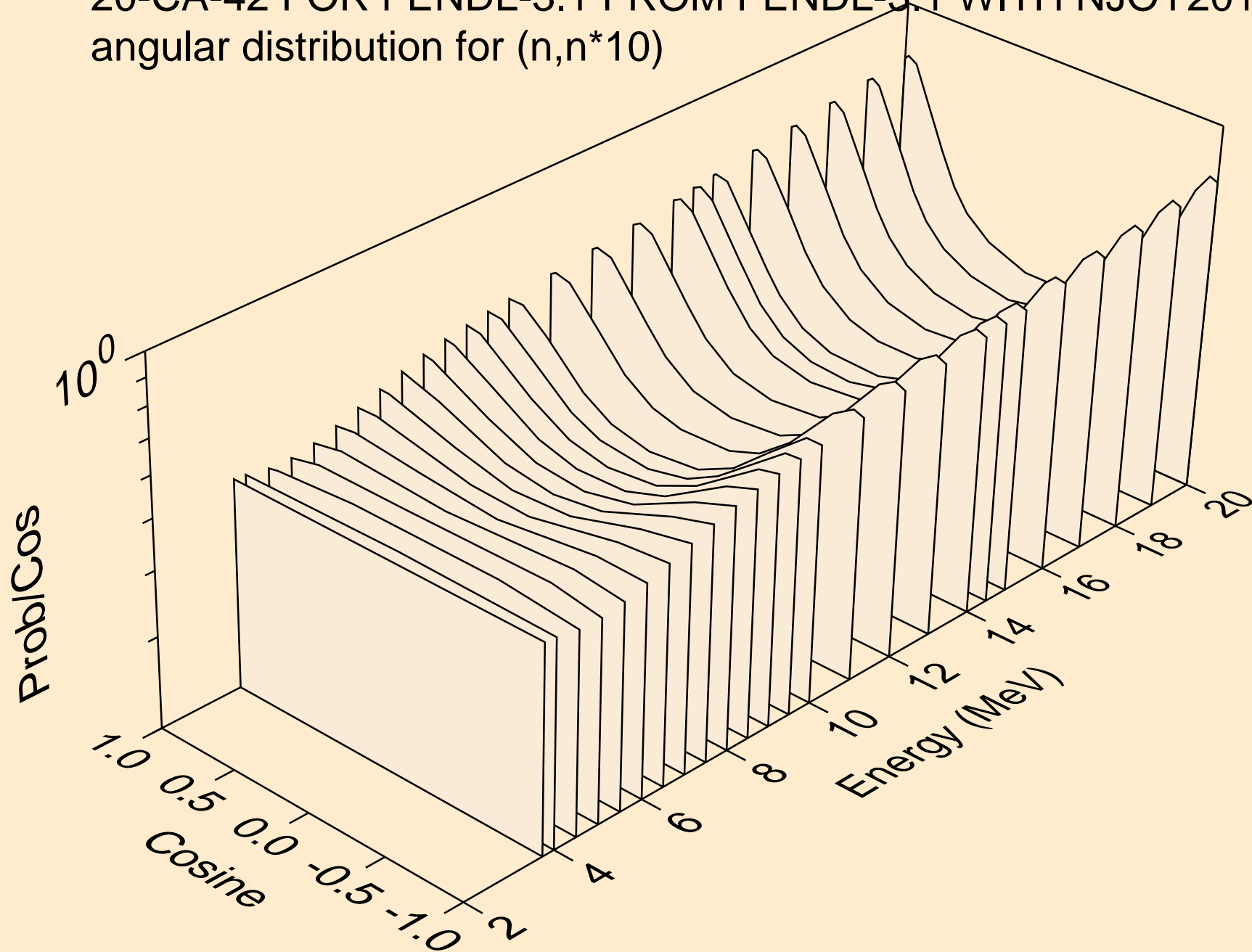

20-CA-42 FOR FENDL-3.1 FROM FENDL-3.1 WITH NJOY2012.50+  
angular distribution for (n,n\*11)

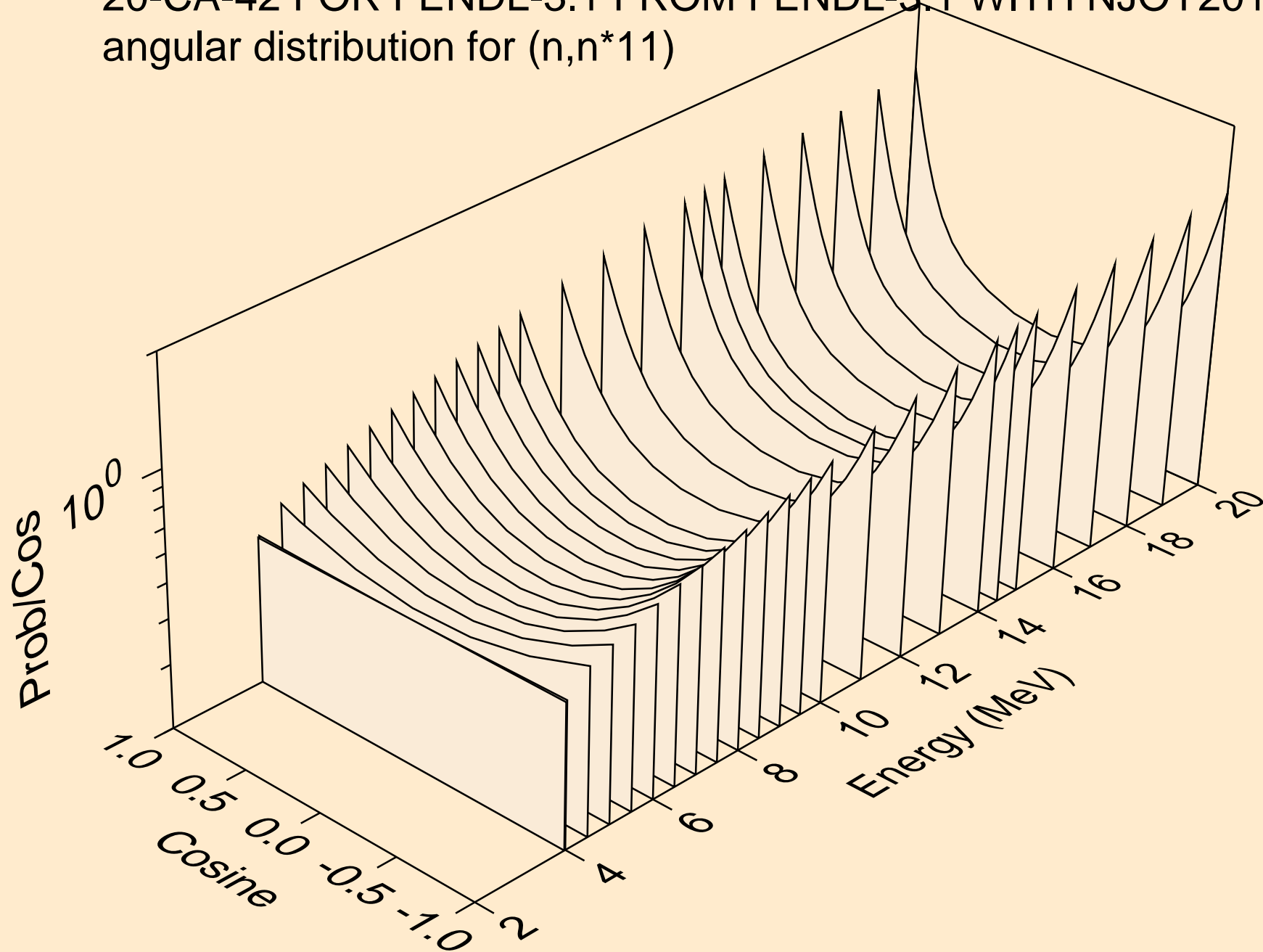

20-CA-42 FOR FENDL-3.1 FROM FENDL-3.1 WITH NJOY2012.50+  
angular distribution for (n,n\*12)

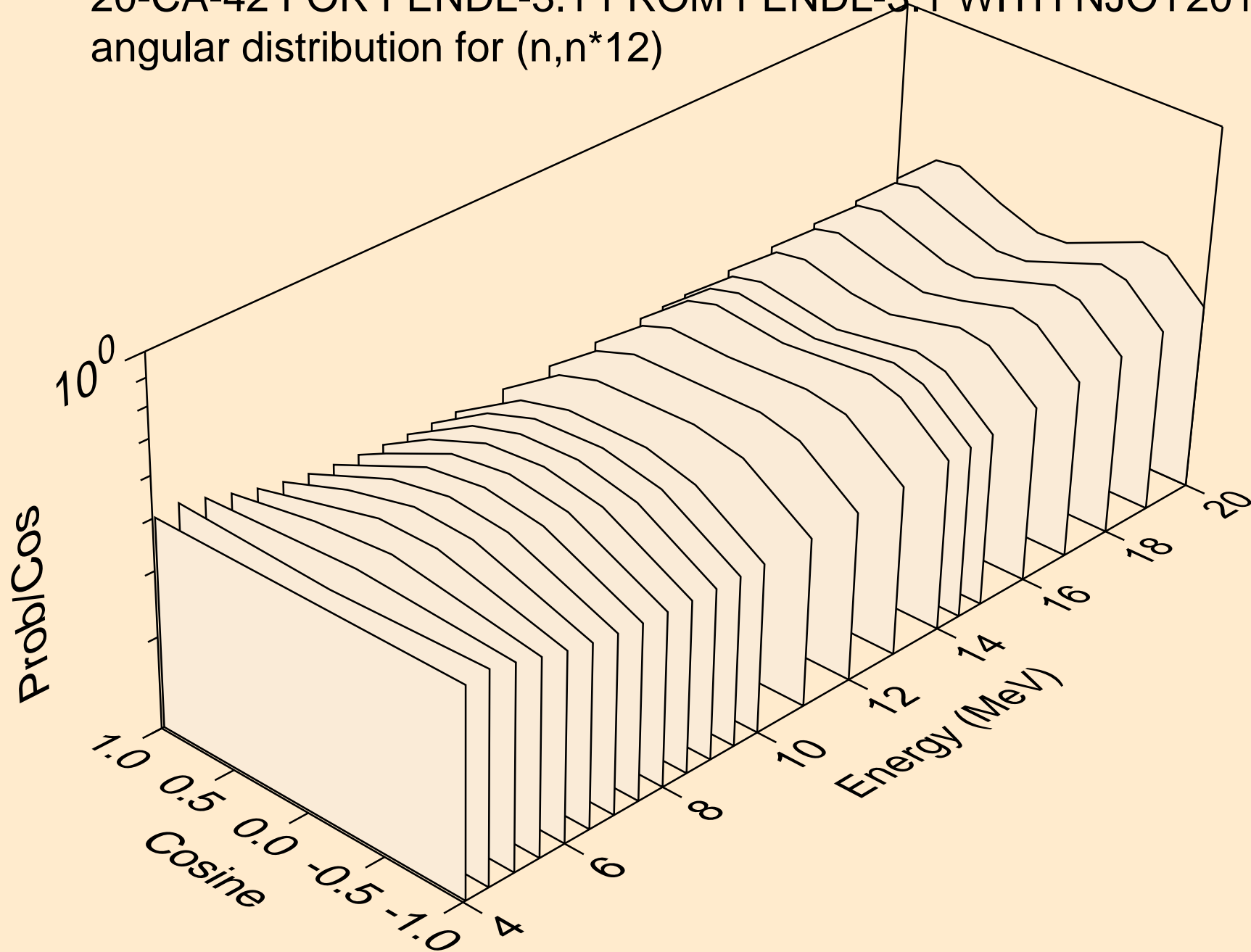



20-CA-42 FOR FENDL-3.1 FROM FENDL-3.1 WITH NJOY2012.50+  
angular distribution for (n,n\*13)

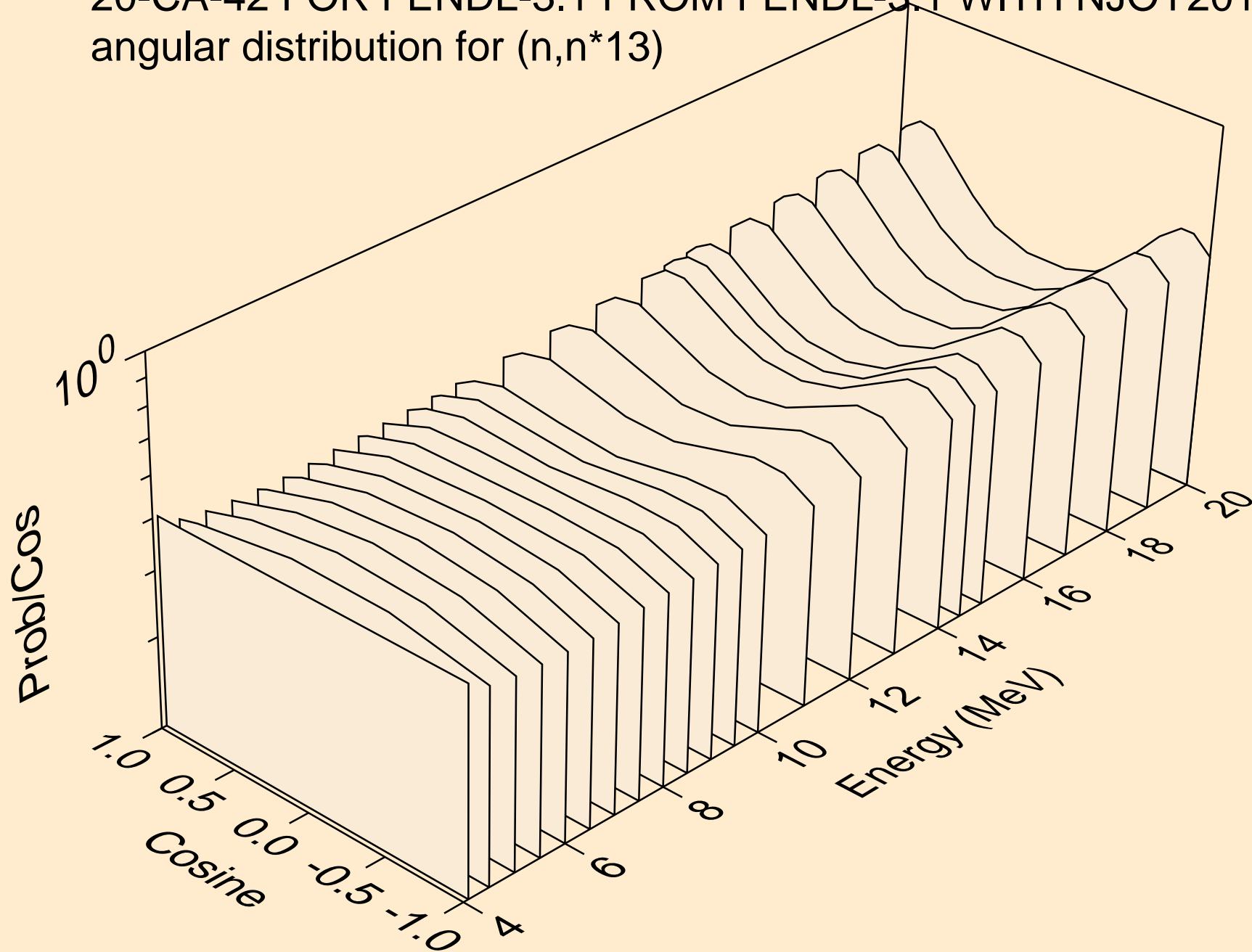

20-CA-42 FOR FENDL-3.1 FROM FENDL-3.1 WITH NJOY2012.50+  
angular distribution for (n,n\*14)

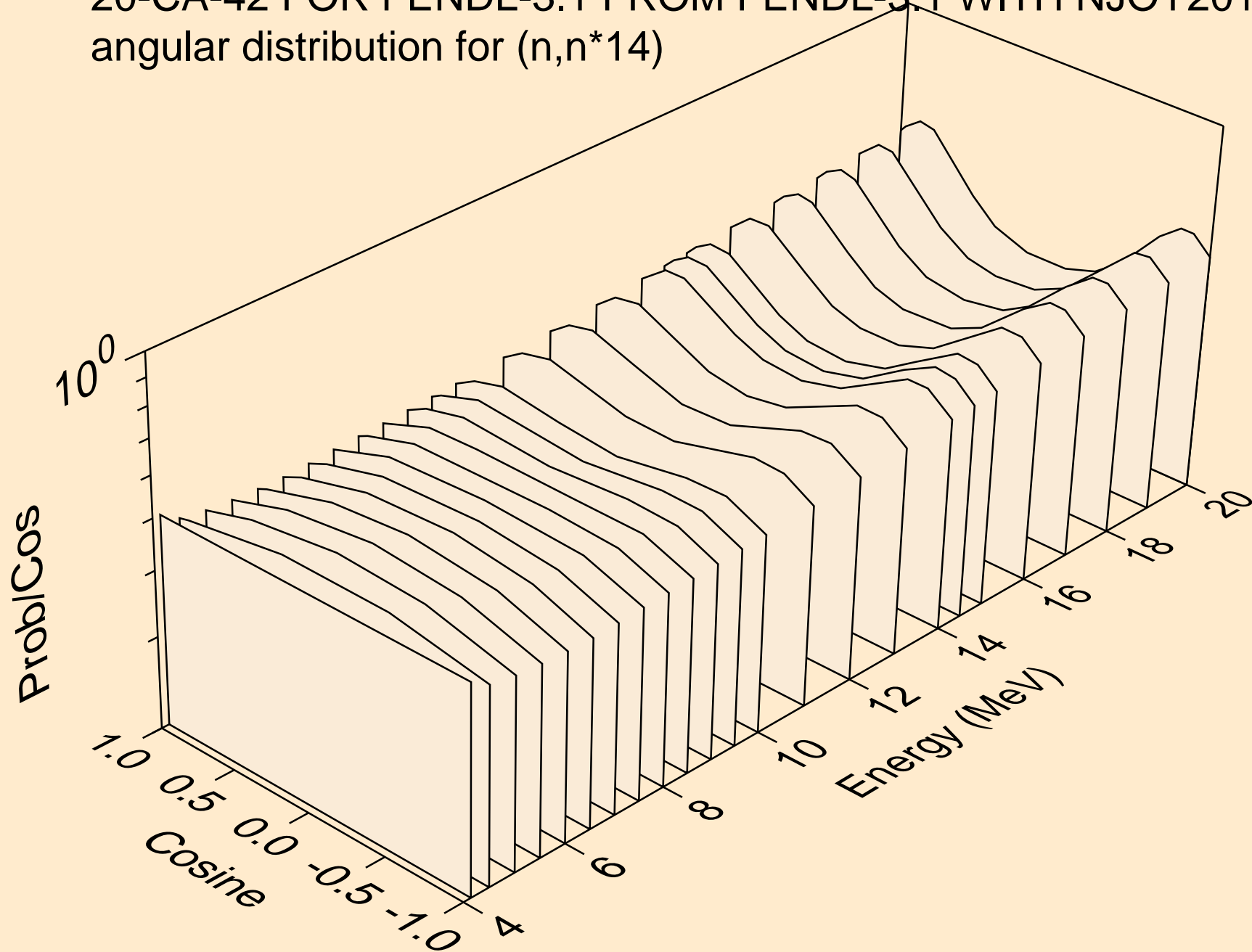

20-CA-42 FOR FENDL-3.1 FROM FENDL-3.1 WITH NJOY2012.50+  
angular distribution for (n,n\*15)

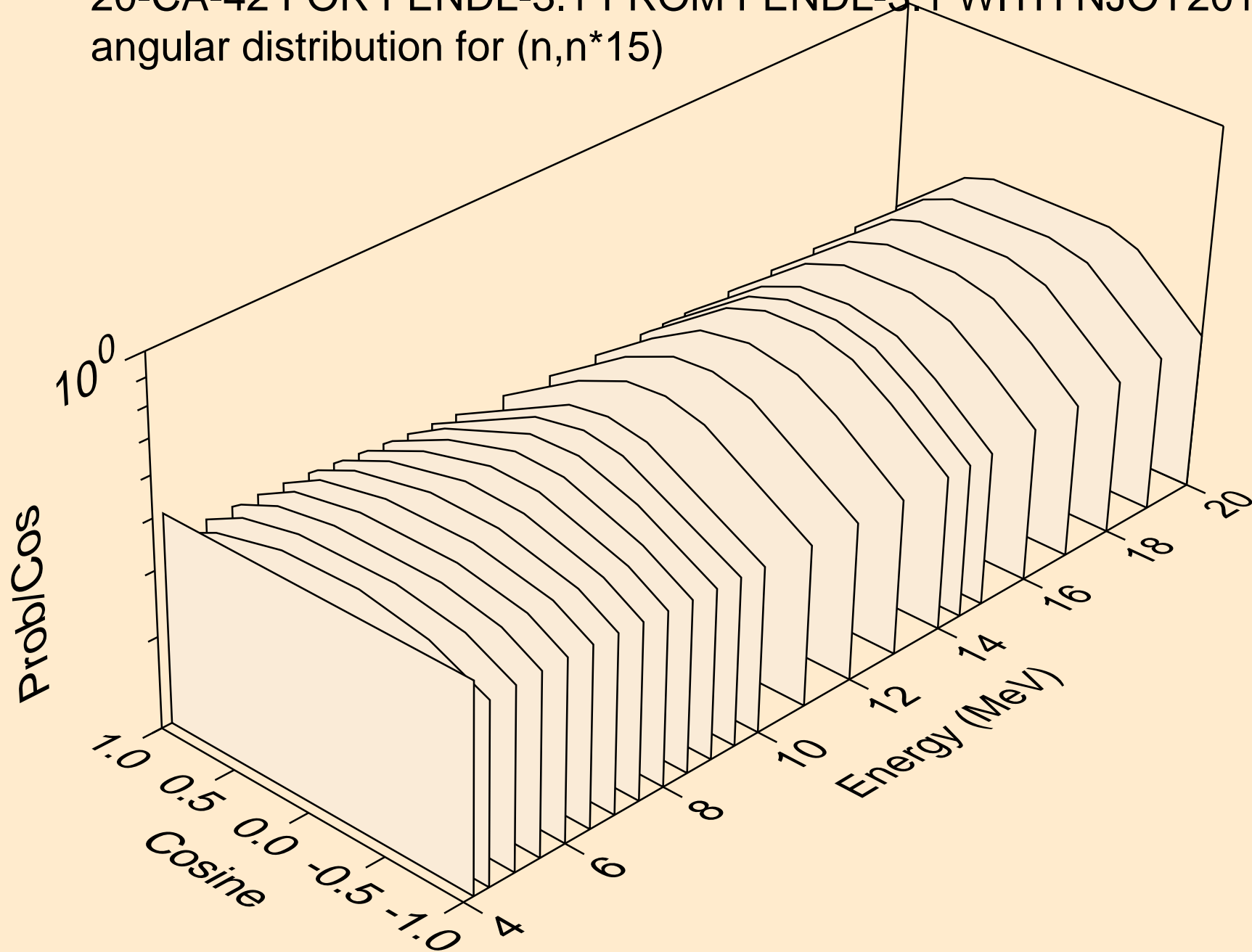

20-CA-42 FOR FENDL-3.1 FROM FENDL-3.1 WITH NJOY2012.50+  
angular distribution for (n,n\*16)

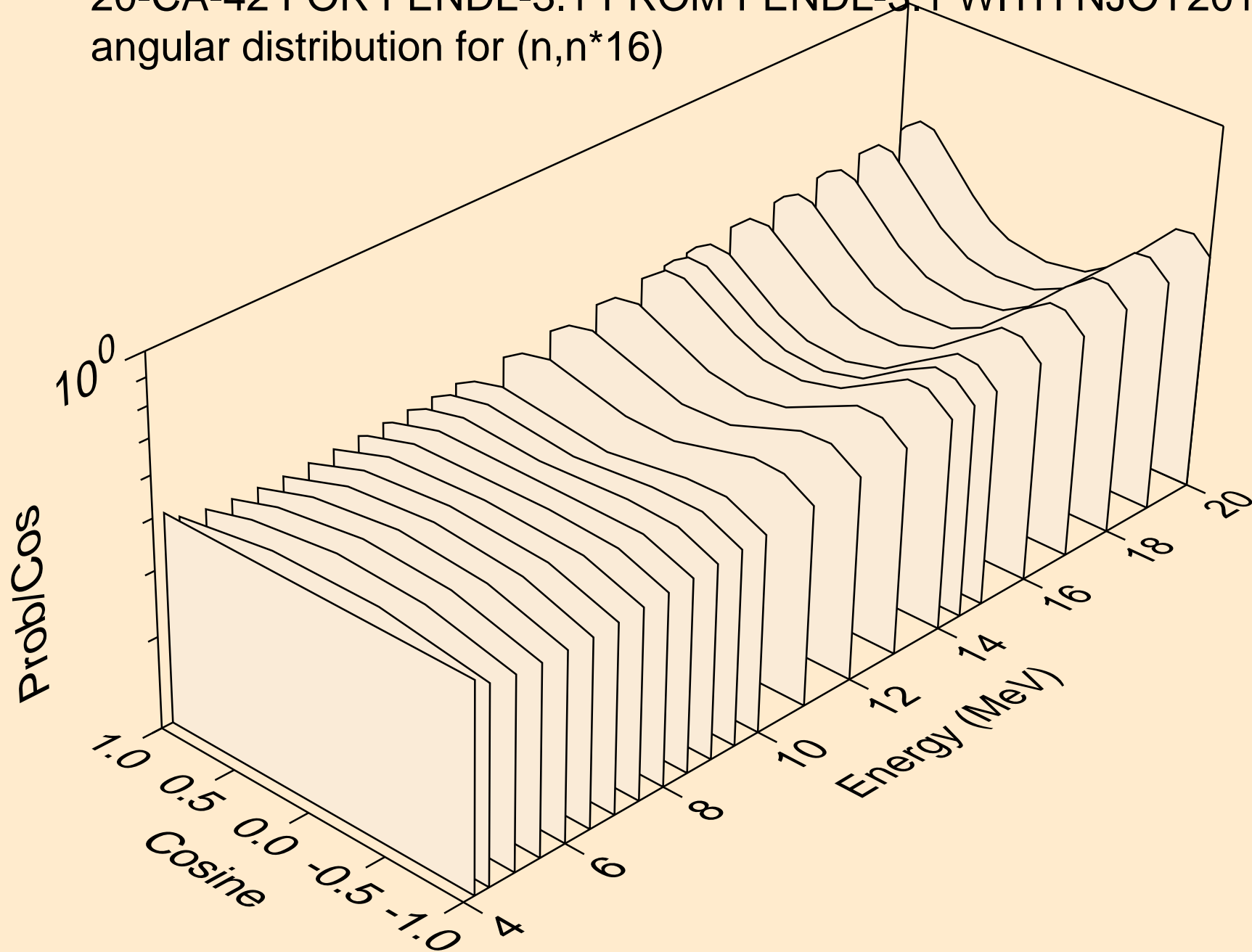

20-CA-42 FOR FENDL-3.1 FROM FENDL-3.1 WITH NJOY2012.50+  
angular distribution for (n,n\*17)

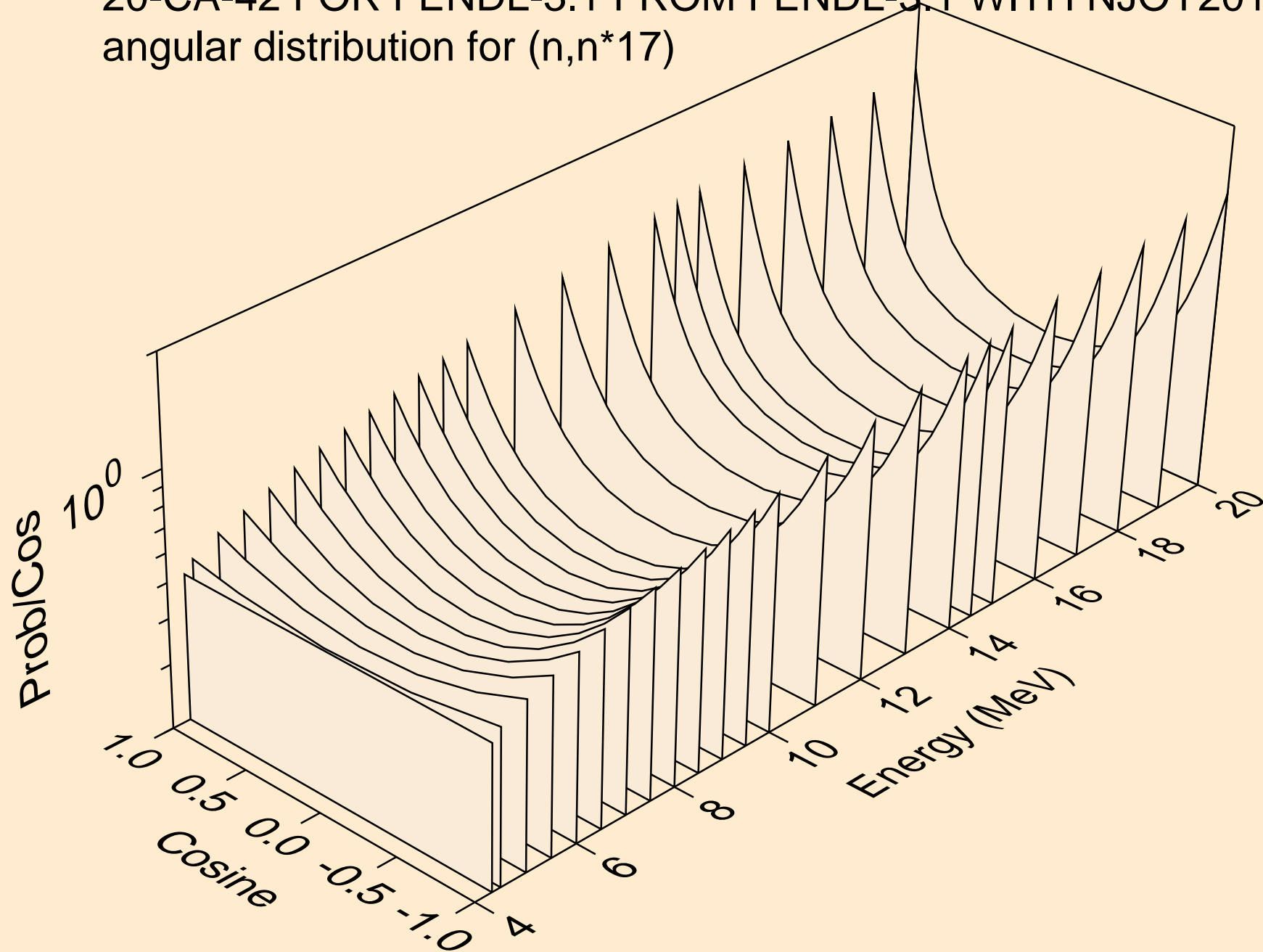

20-CA-42 FOR FENDL-3.1 FROM FENDL-3.1 WITH NJOY2012.50+  
angular distribution for (n,n\*18)

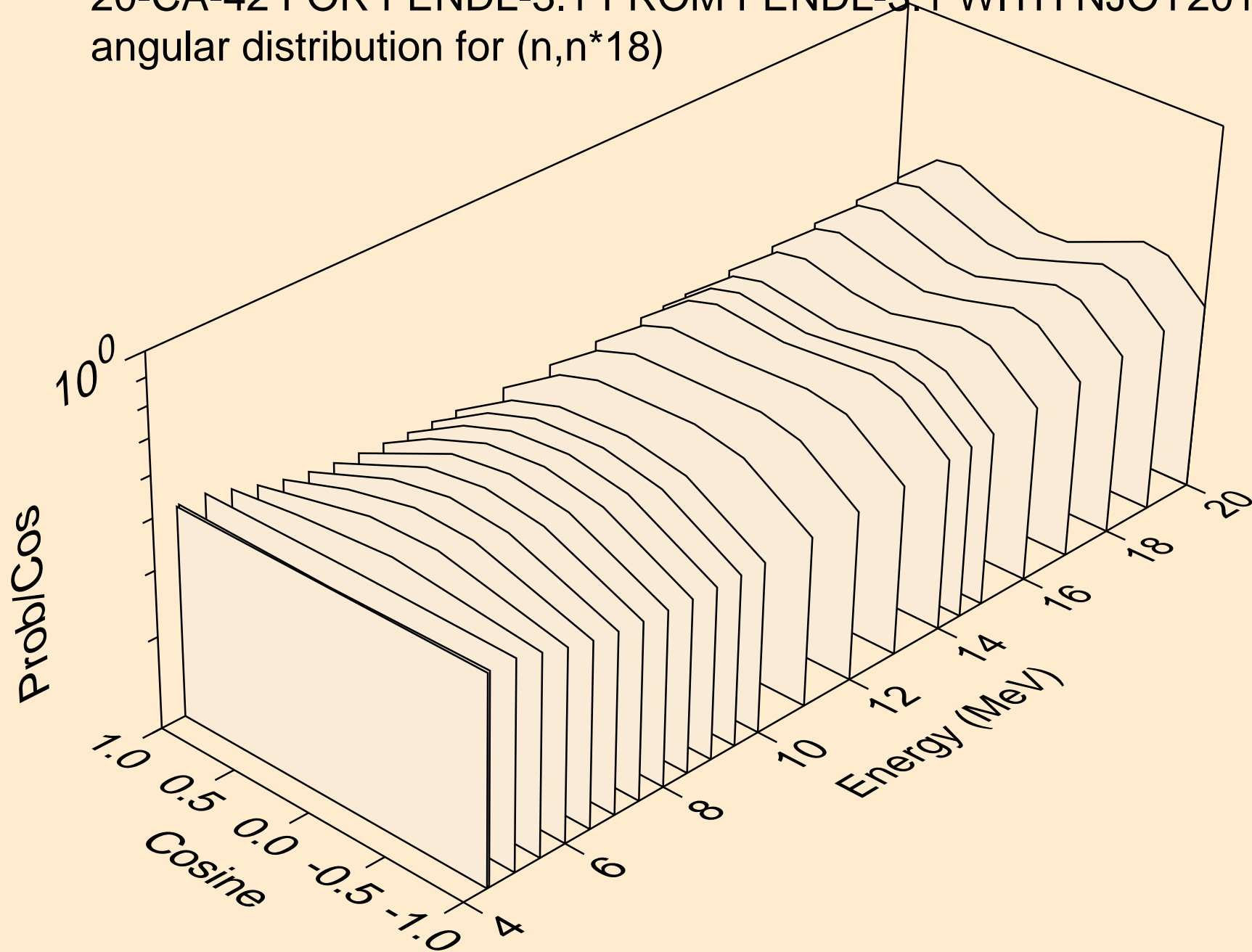

20-CA-42 FOR FENDL-3.1 FROM FENDL-3.1 WITH NJOY2012.50+  
angular distribution for (n,n\*19)

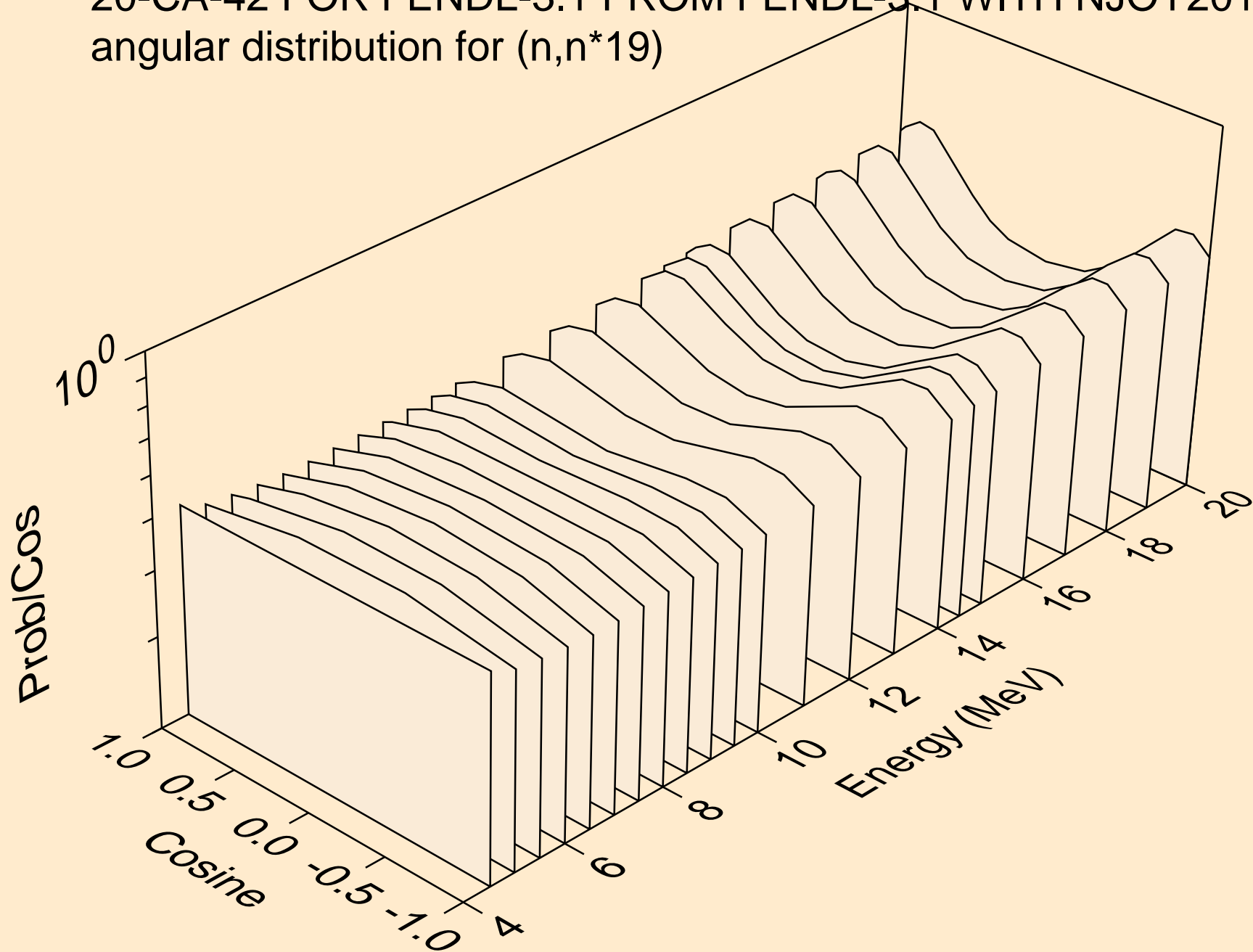

20-CA-42 FOR FENDL-3.1 FROM FENDL-3.1 WITH NJOY2012.50+  
angular distribution for (n,n\*20)

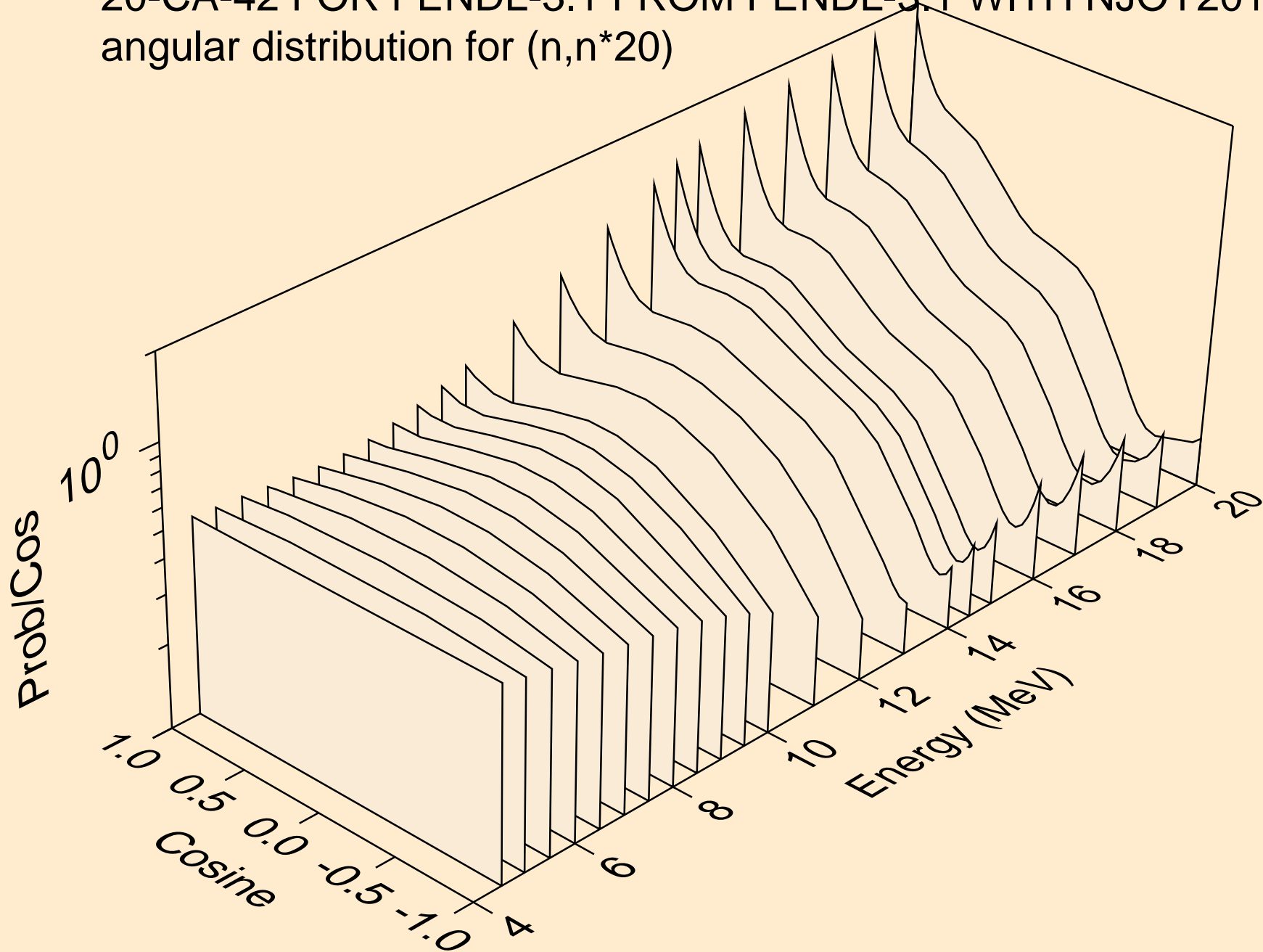



20-CA-42 FOR FENDL-3.1 FROM FENDL-3.1 WITH NJOY2012.50+  
angular distribution for (n,n\*21)

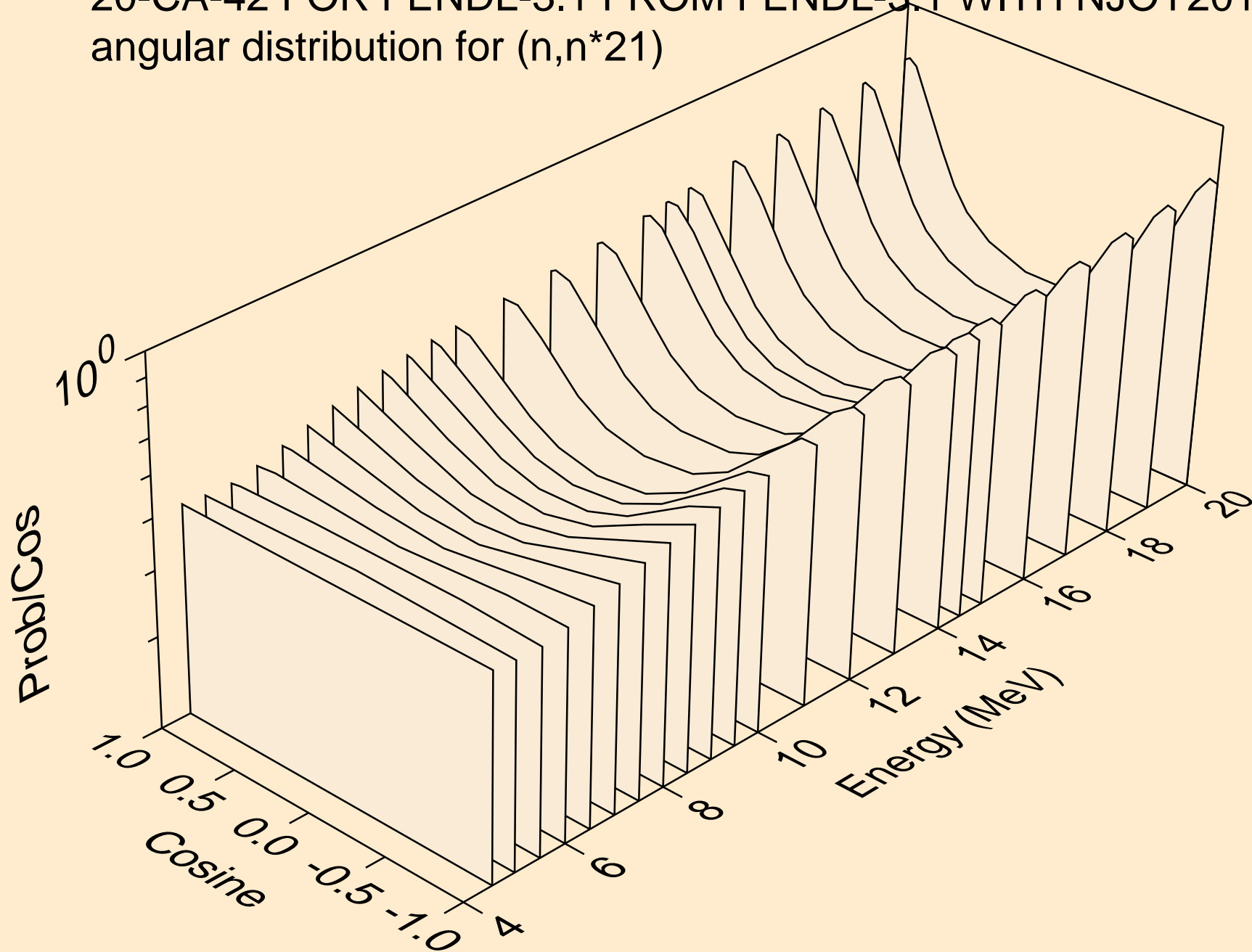

20-CA-42 FOR FENDL-3.1 FROM FENDL-3.1 WITH NJOY2012.50+  
angular distribution for (n,n\*22)

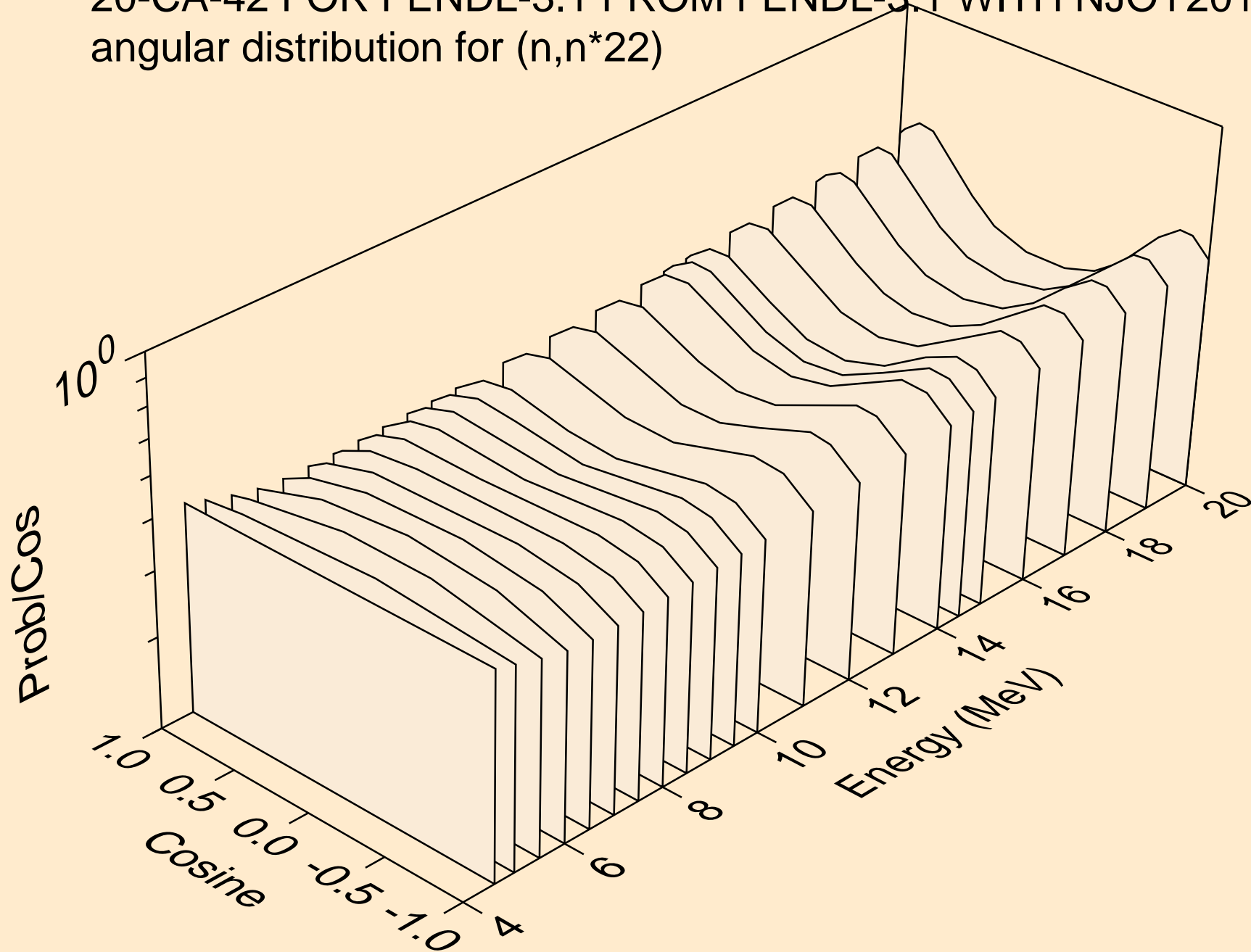

20-CA-42 FOR FENDL-3.1 FROM FENDL-3.1 WITH NJOY2012.50+  
angular distribution for (n,n\*23)

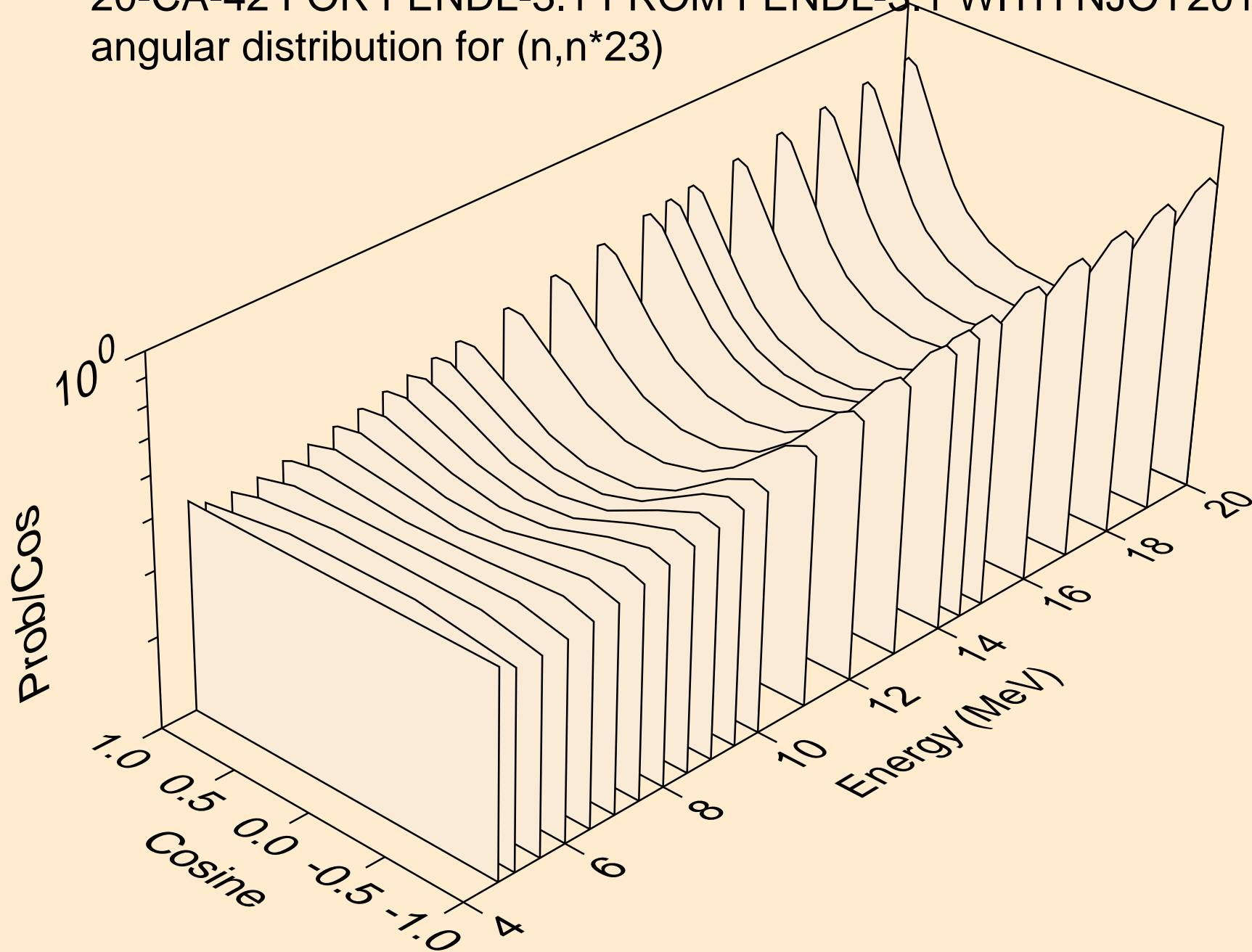

20-CA-42 FOR FENDL-3.1 FROM FENDL-3.1 WITH NJOY2012.50+  
angular distribution for (n,n\*24)

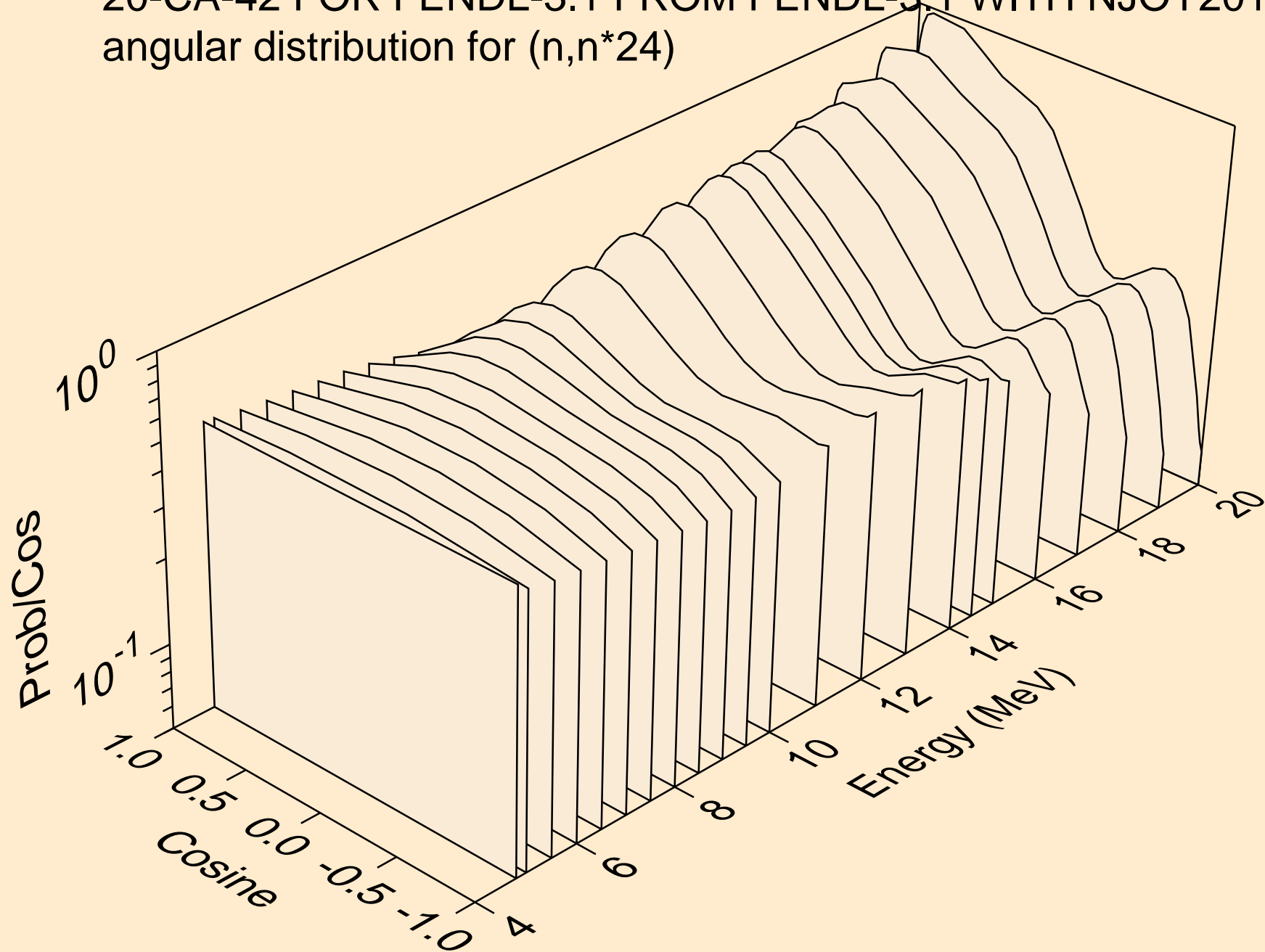

20-CA-42 FOR FENDL-3.1 FROM FENDL-3.1 WITH NJOY2012.50+  
angular distribution for (n,n\*25)

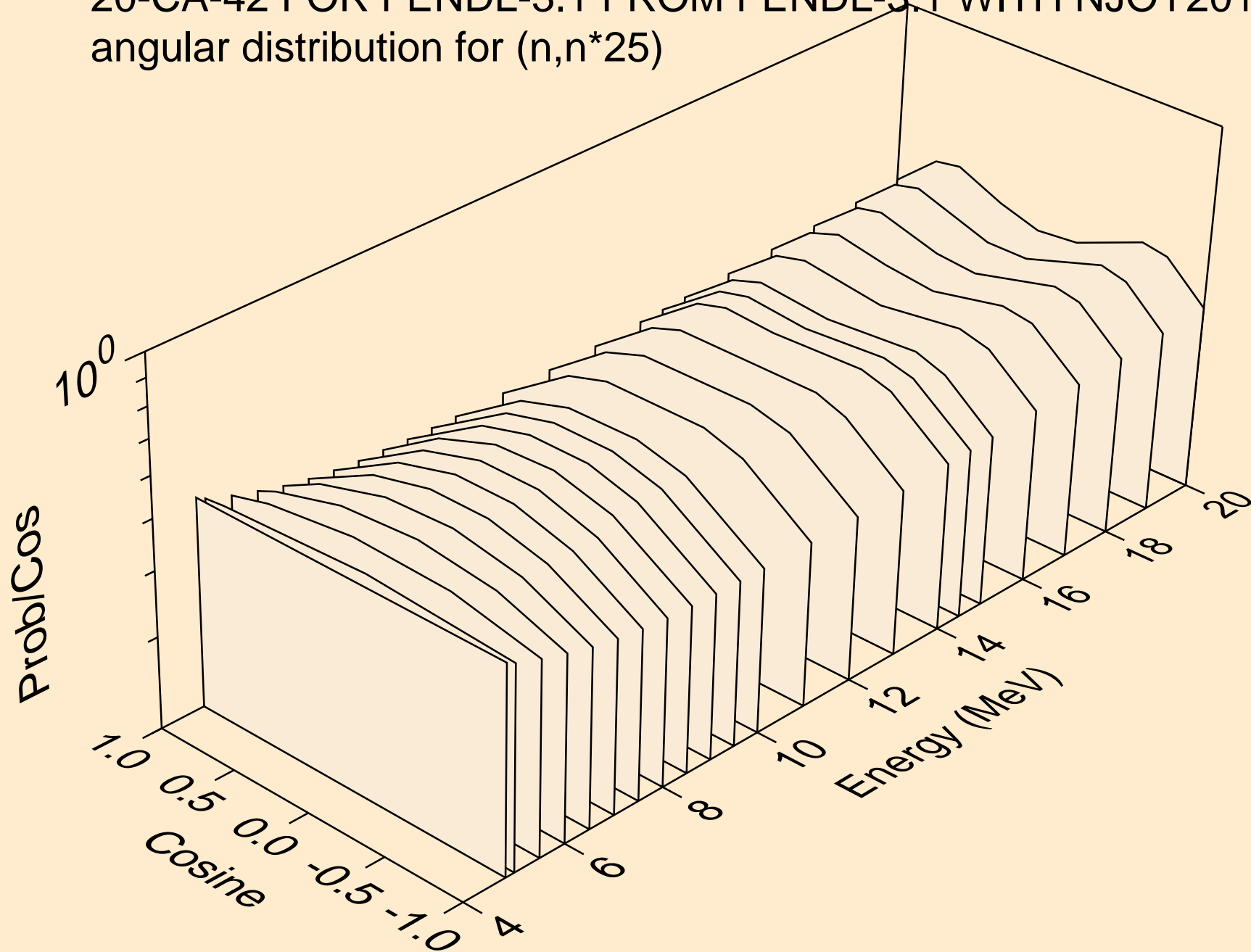

20-CA-42 FOR FENDL-3.1 FROM FENDL-3.1 WITH NJOY2012.50+  
angular distribution for (n,n\*26)

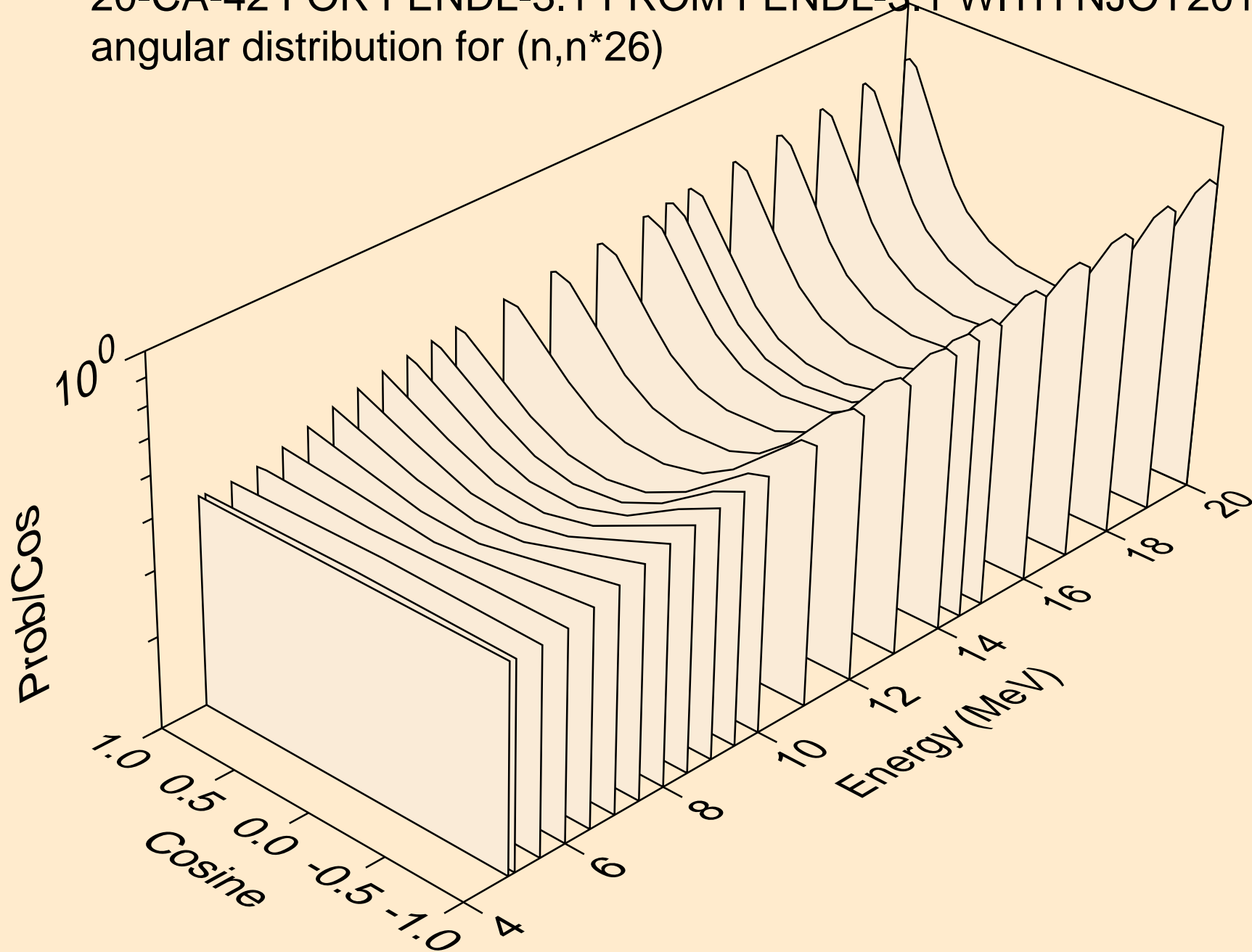

20-CA-42 FOR FENDL-3.1 FROM FENDL-3.1 WITH NJOY2012.50+  
angular distribution for (n,n\*27)

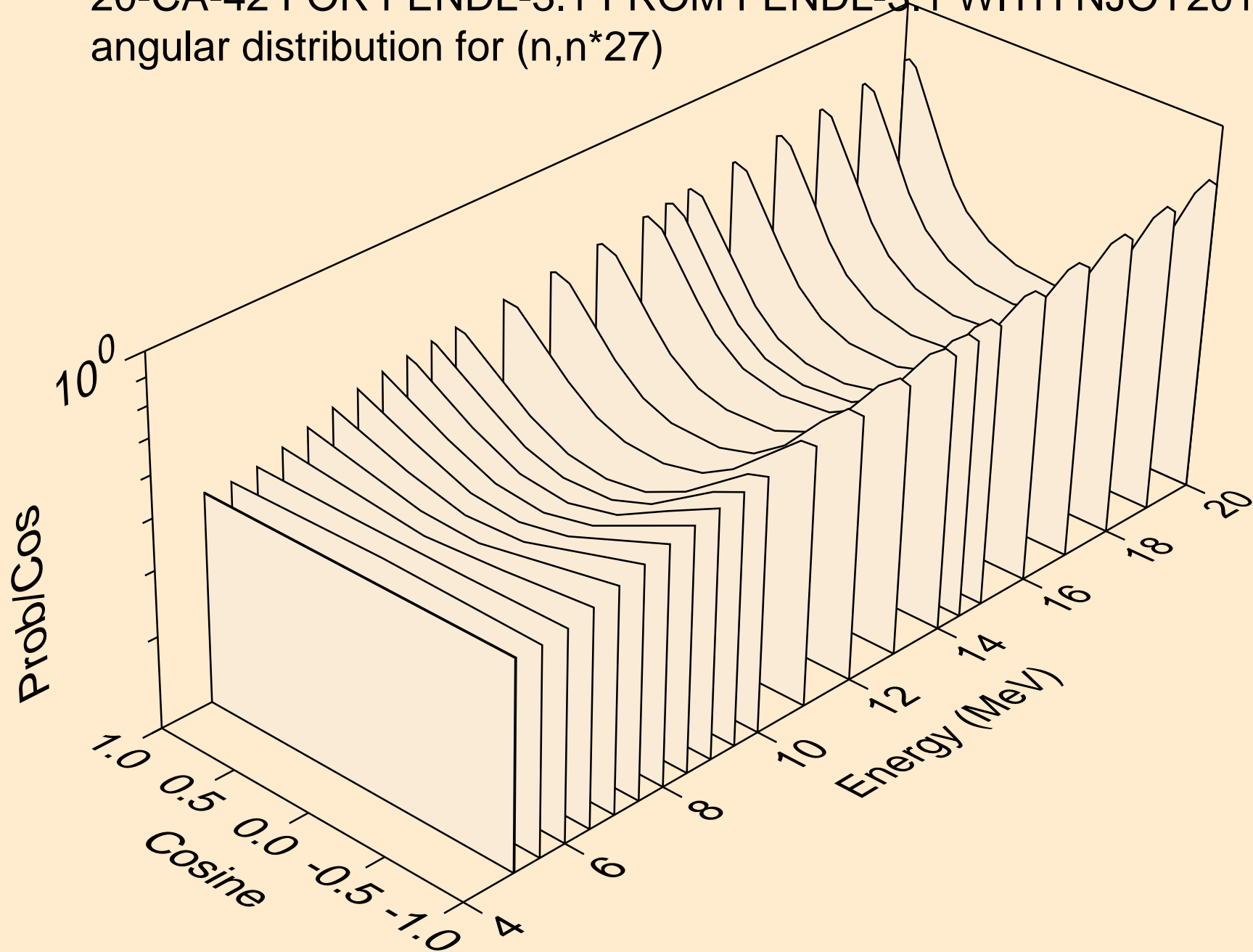

20-CA-42 FOR FENDL-3.1 FROM FENDL-3.1 WITH NJOY2012.50+  
angular distribution for (n,n\*28)

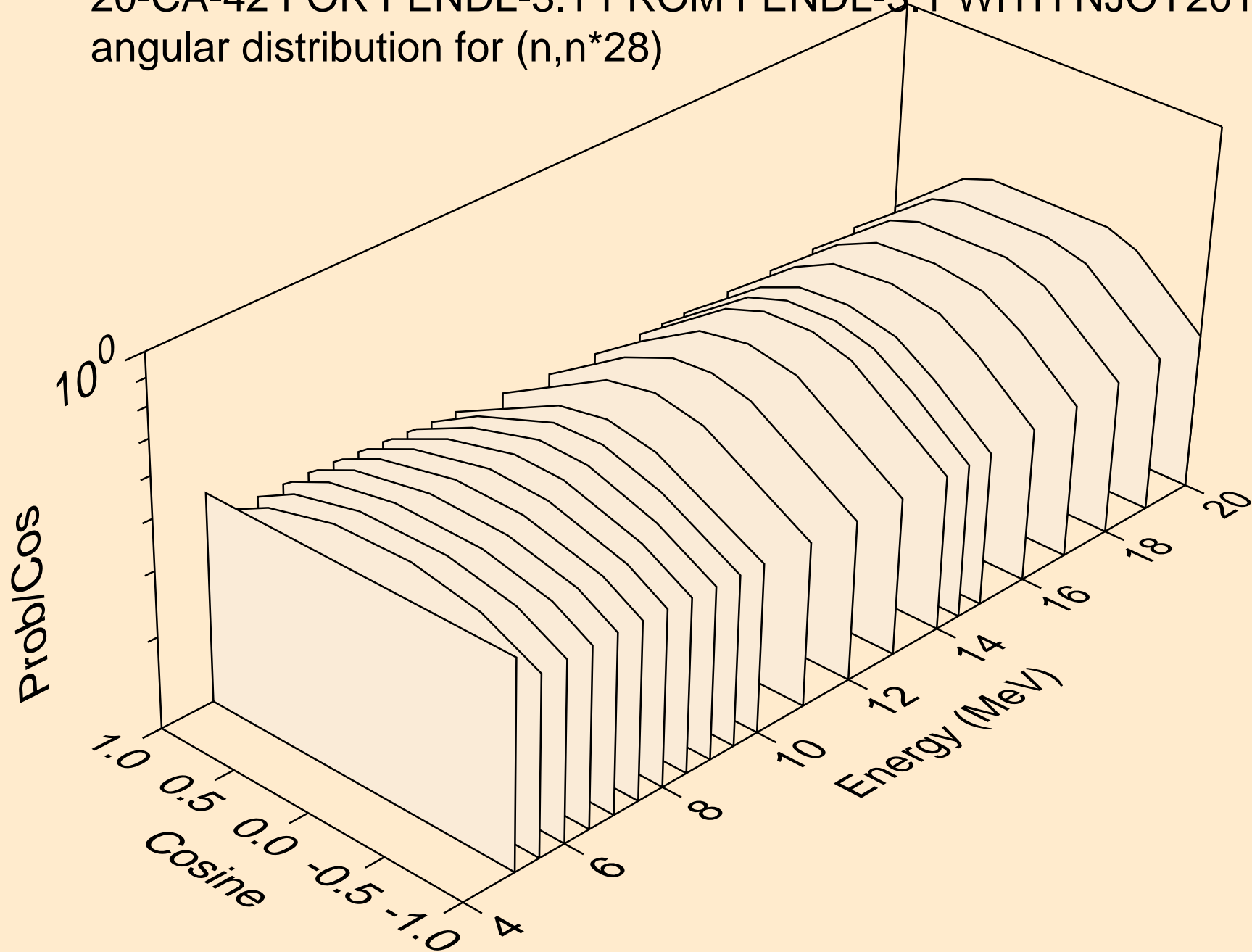



20-CA-42 FOR FENDL-3.1 FROM FENDL-3.1 WITH NJOY2012.50+  
angular distribution for (n,n\*29)

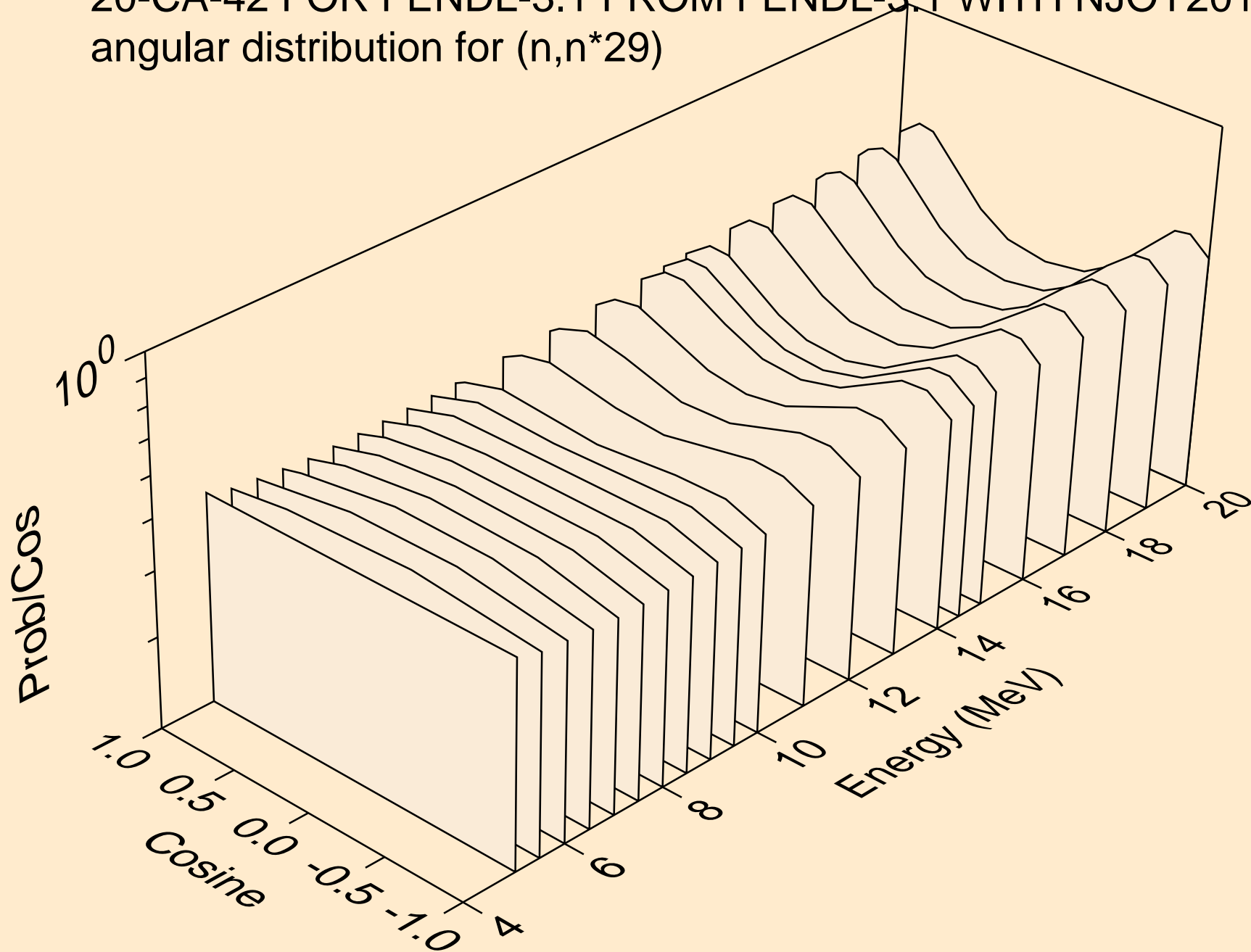

20-CA-42 FOR FENDL-3.1 FROM FENDL-3.1 WITH NJOY2012.50+  
angular distribution for (n,n\*30)

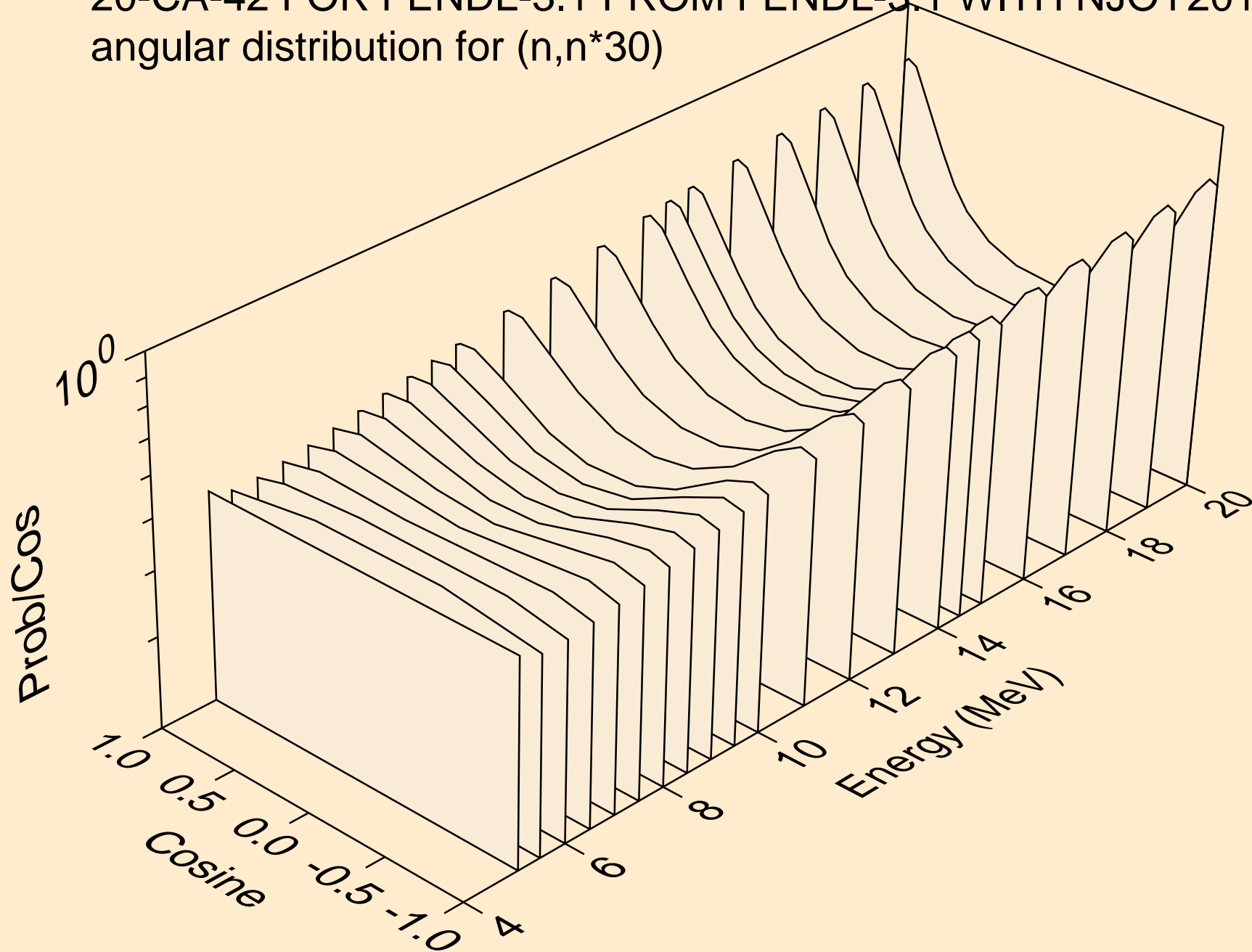

20-CA-42 FOR FENDL-3.1 FROM FENDL-3.1 WITH NJOY2012.50+  
angular distribution for (n,n\*31)

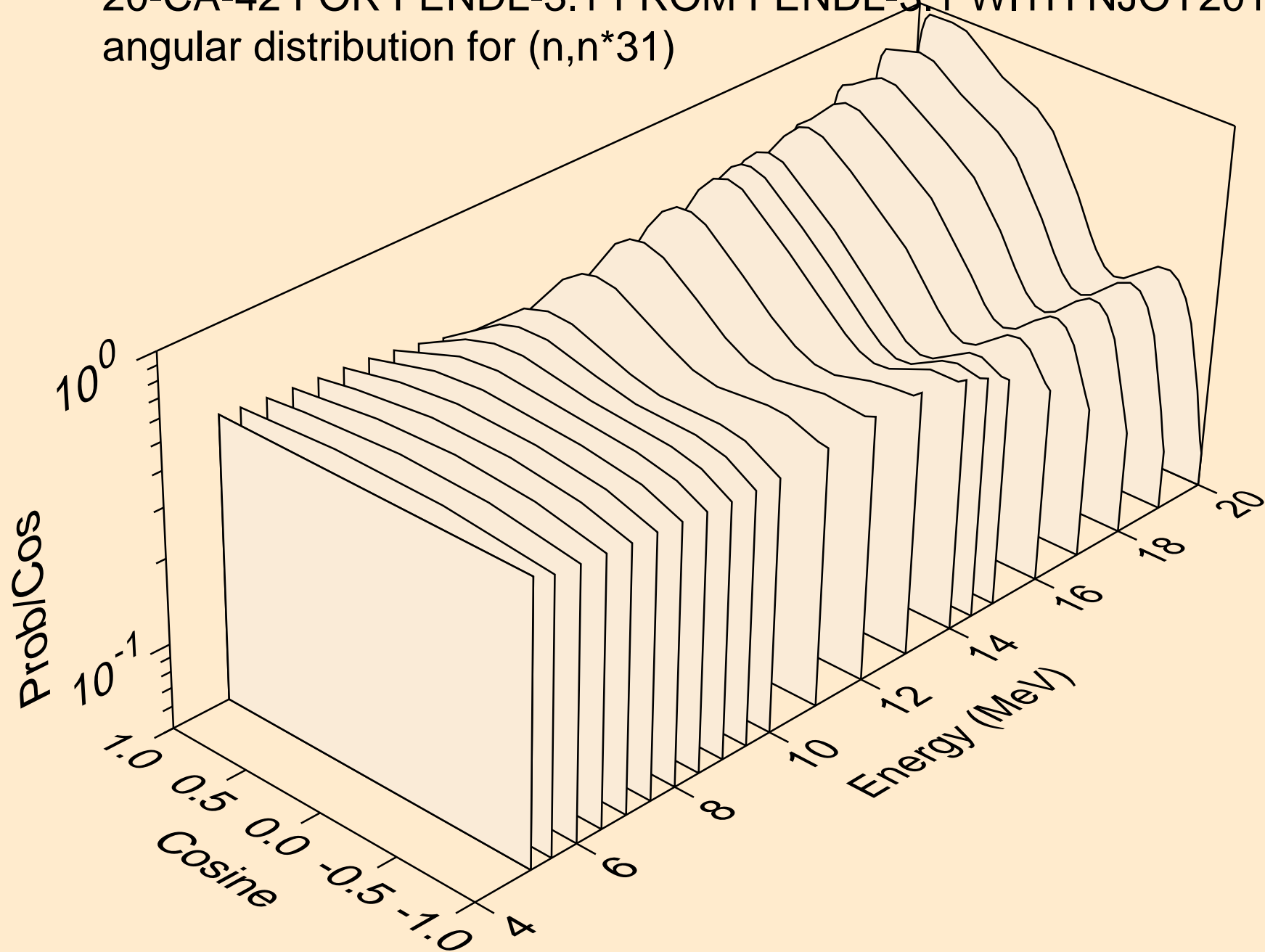

20-CA-42 FOR FENDL-3.1 FROM FENDL-3.1 WITH NJOY2012.50+  
angular distribution for (n,n\*32)

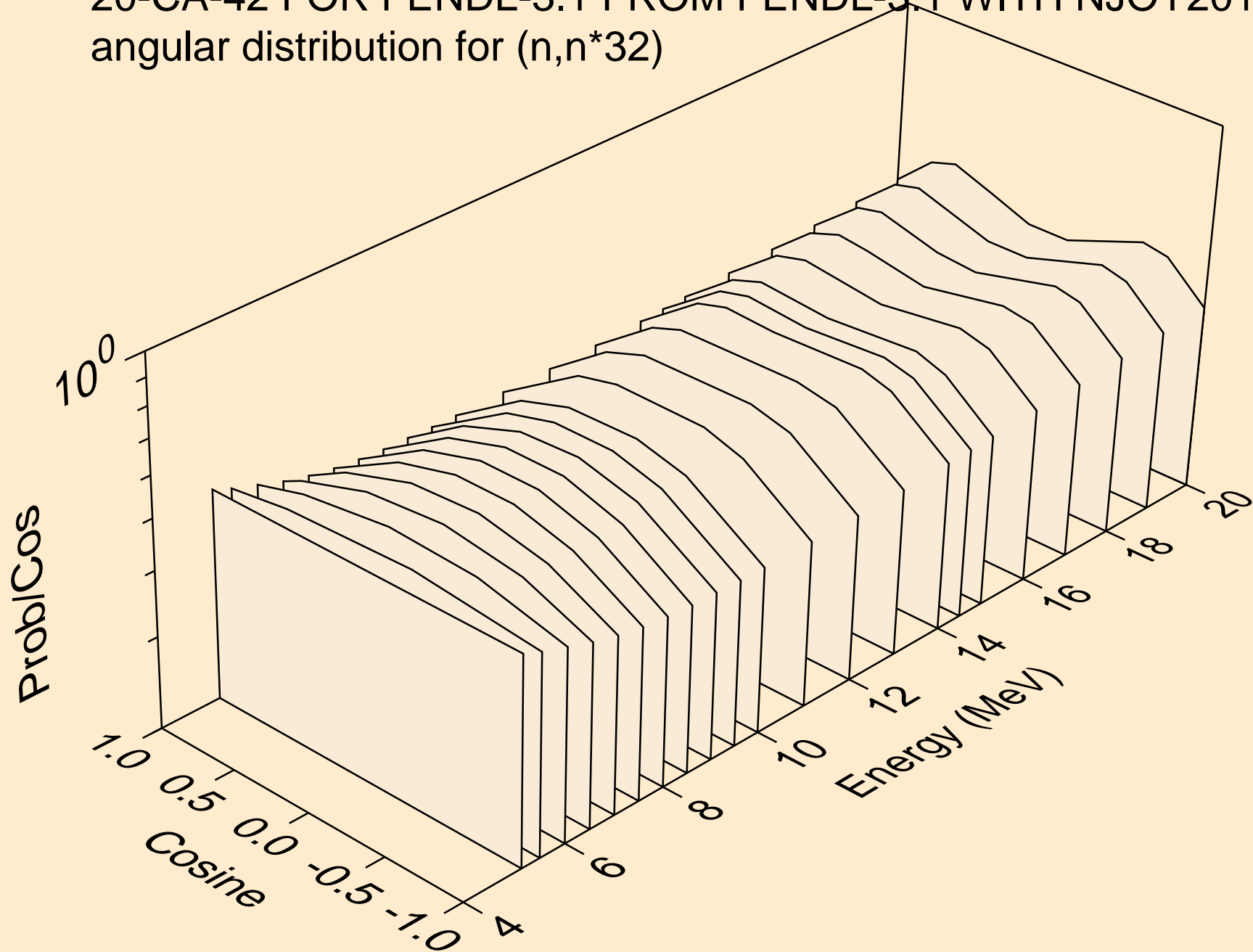

20-CA-42 FOR FENDL-3.1 FROM FENDL-3.1 WITH NJOY2012.50+  
angular distribution for (n,n\*33)

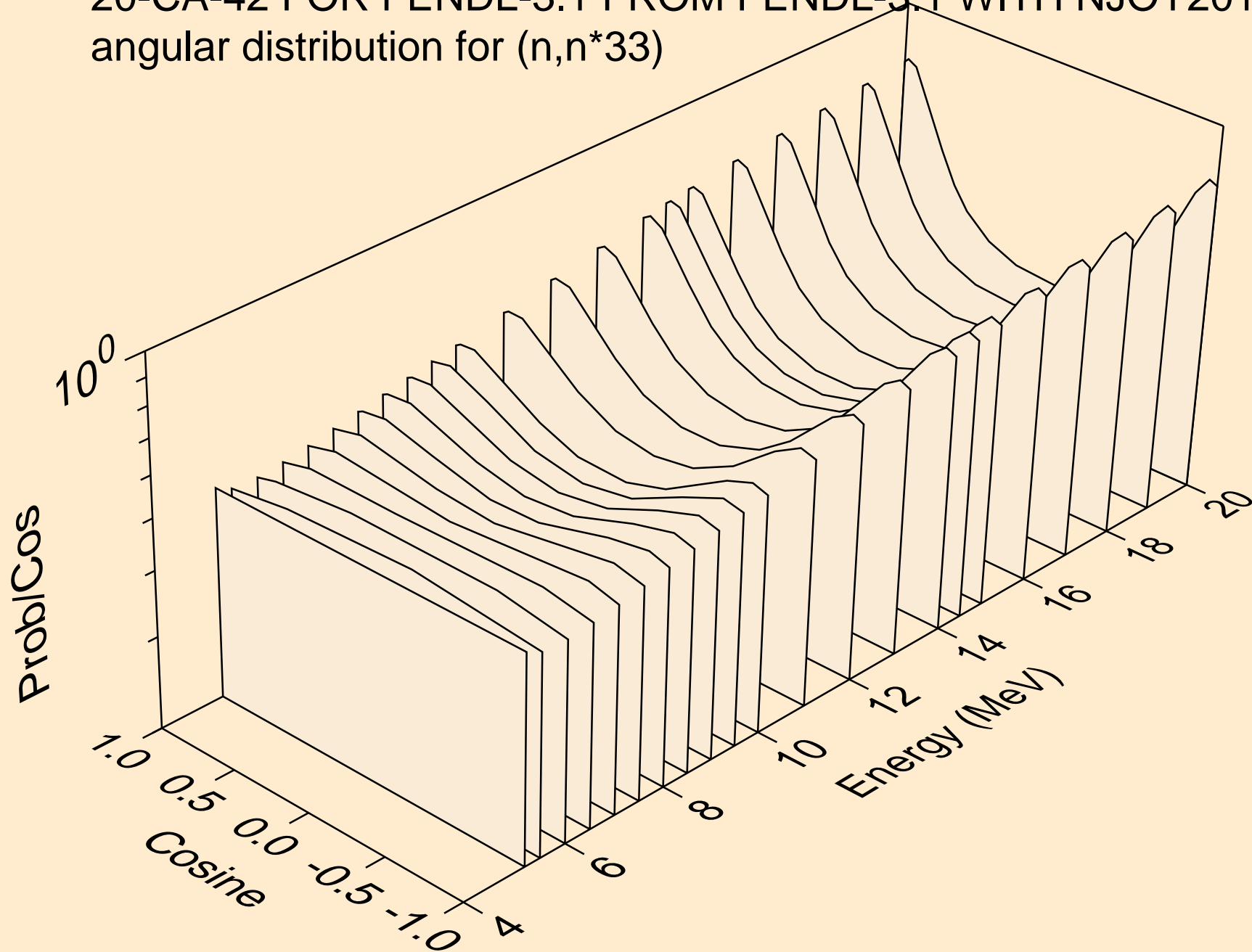

20-CA-42 FOR FENDL-3.1 FROM FENDL-3.1 WITH NJOY2012.50+  
angular distribution for (n,n\*34)

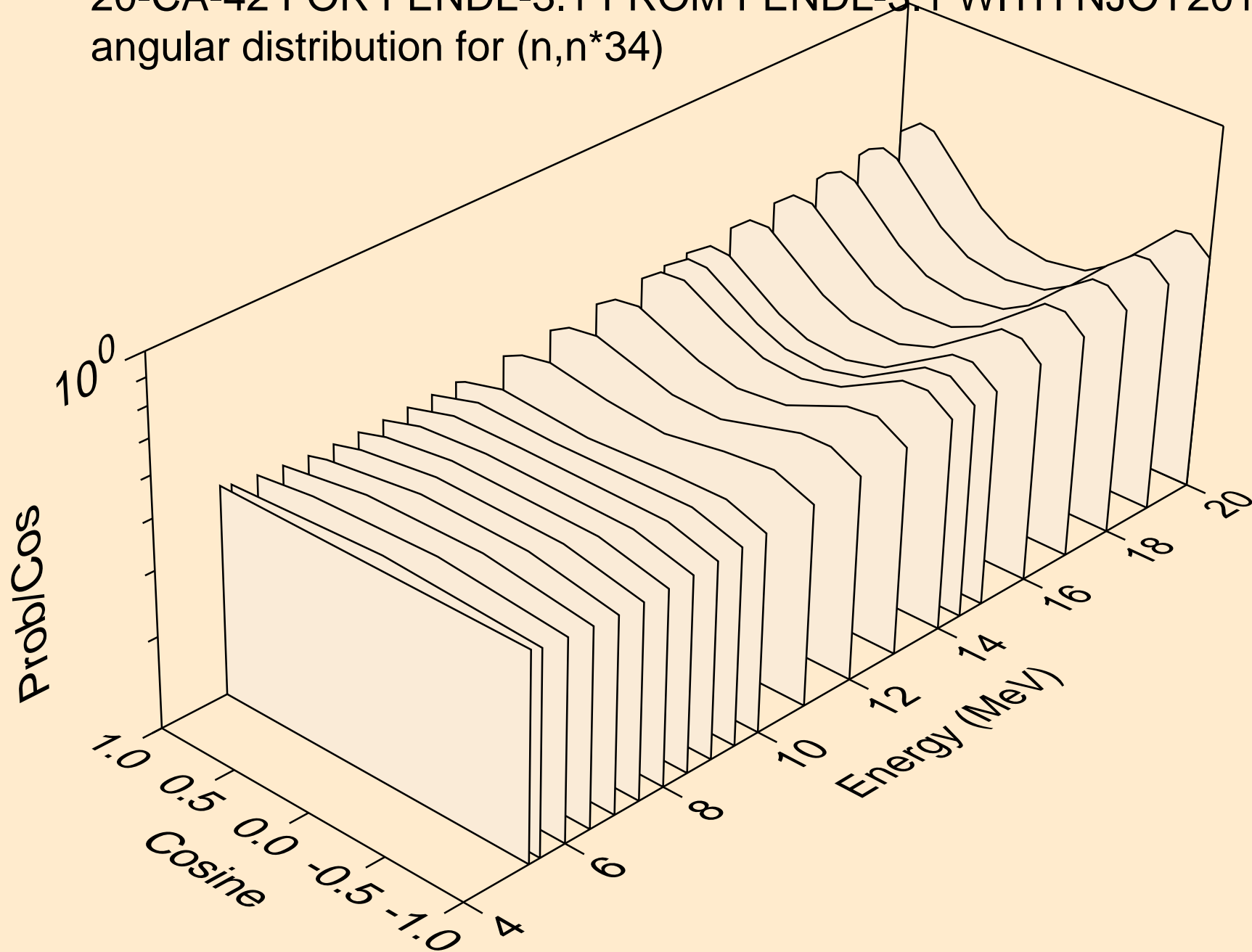

20-CA-42 FOR FENDL-3.1 FROM FENDL-3.1 WITH NJOY2012.50+  
angular distribution for (n,n\*35)

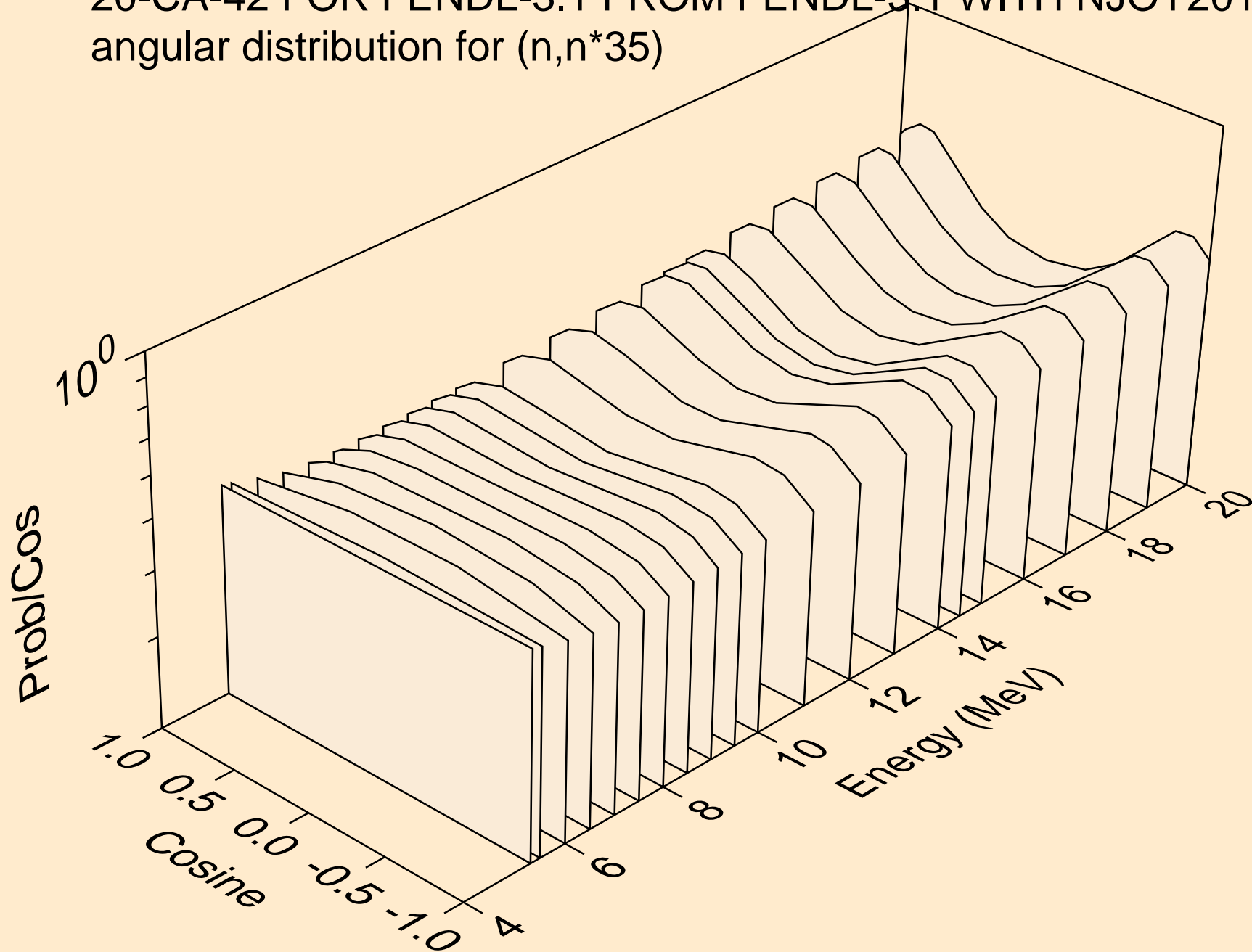

20-CA-42 FOR FENDL-3.1 FROM FENDL-3.1 WITH NJOY2012.50+  
angular distribution for (n,n\*36)

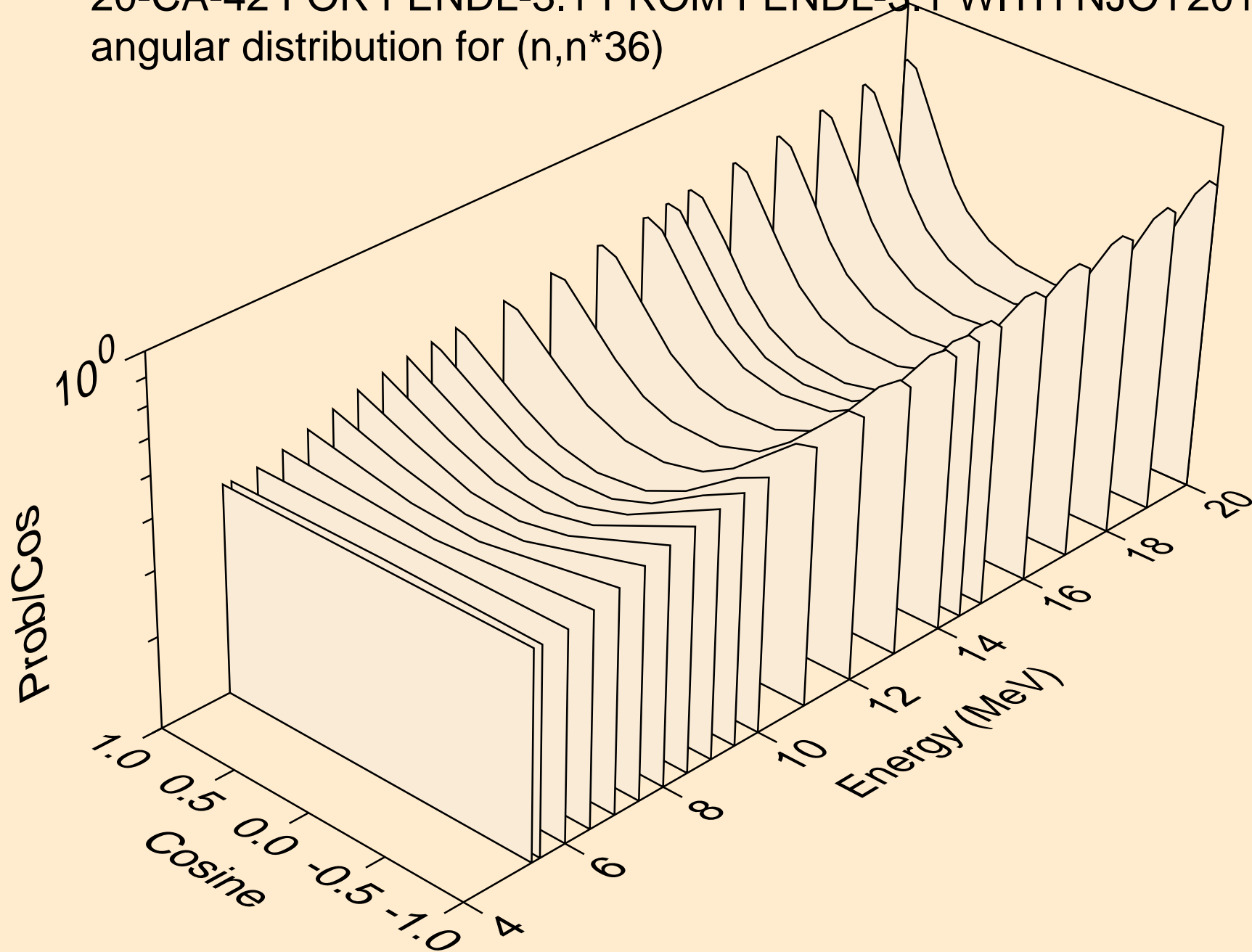



20-CA-42 FOR FENDL-3.1 FROM FENDL-3.1 WITH NJOY2012.50+  
angular distribution for (n,n\*37)

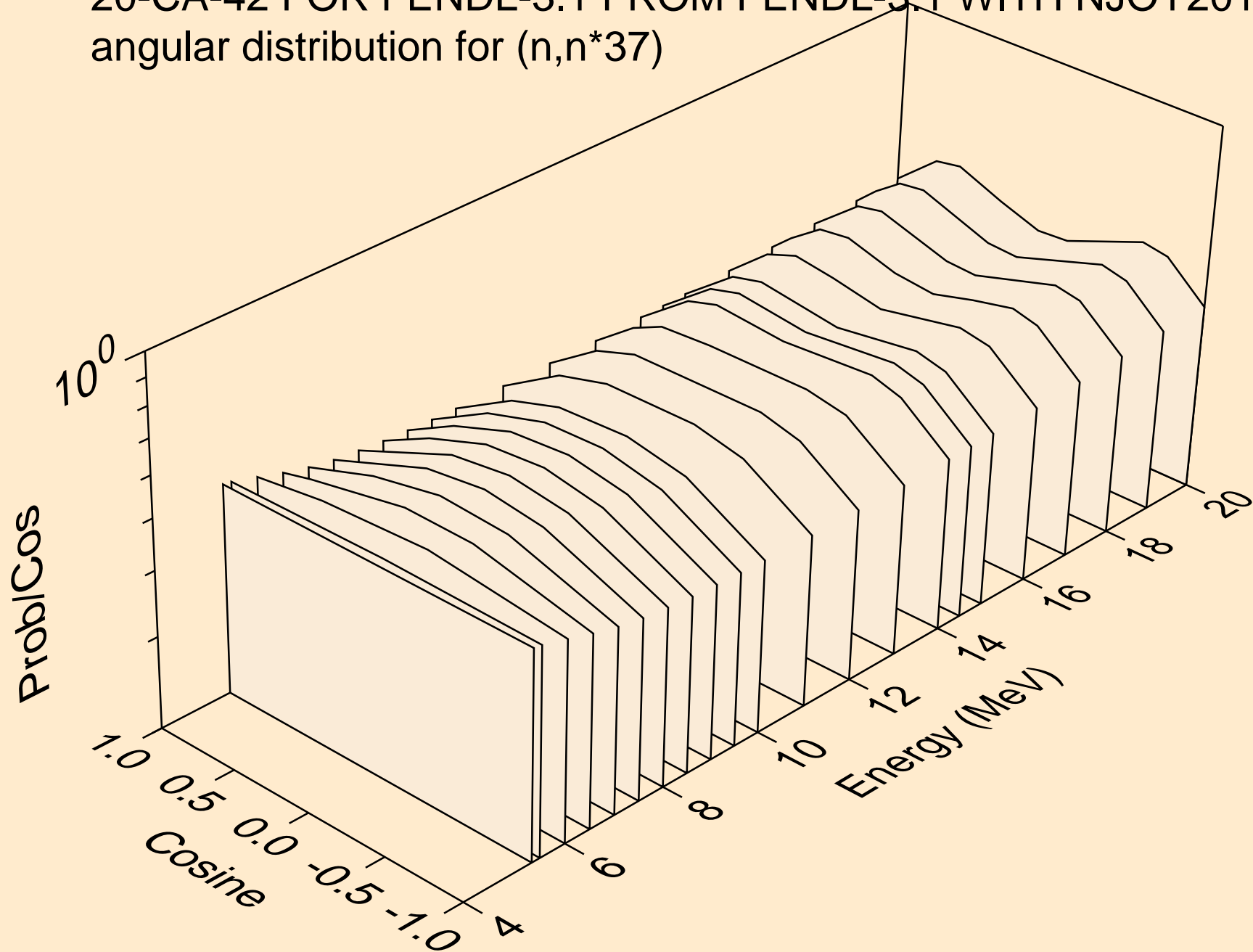

20-CA-42 FOR FENDL-3.1 FROM FENDL-3.1 WITH NJOY2012.50+  
angular distribution for (n,n\*38)

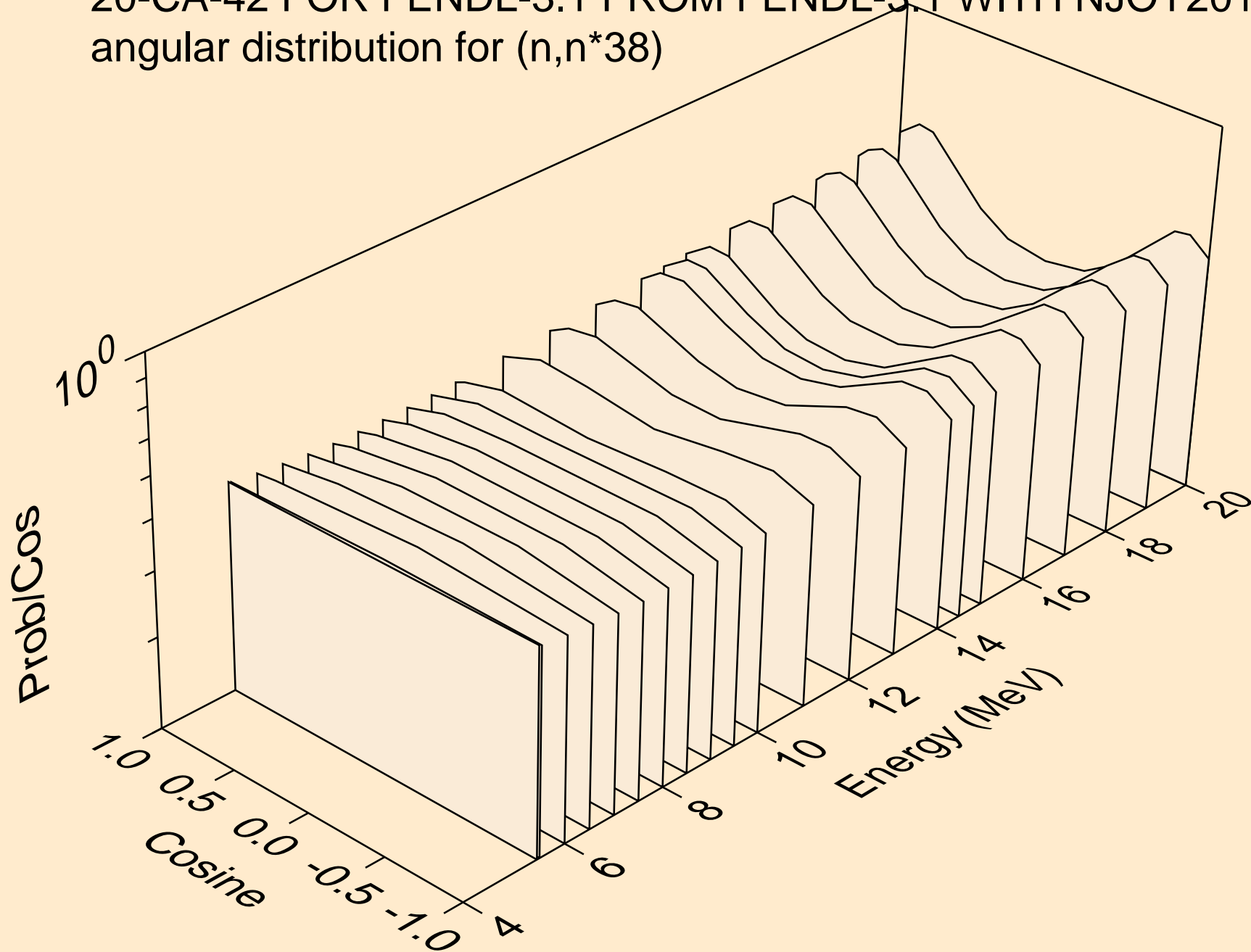

20-CA-42 FOR FENDL-3.1 FROM FENDL-3.1 WITH NJOY2012.50+  
angular distribution for (n,n\*39)

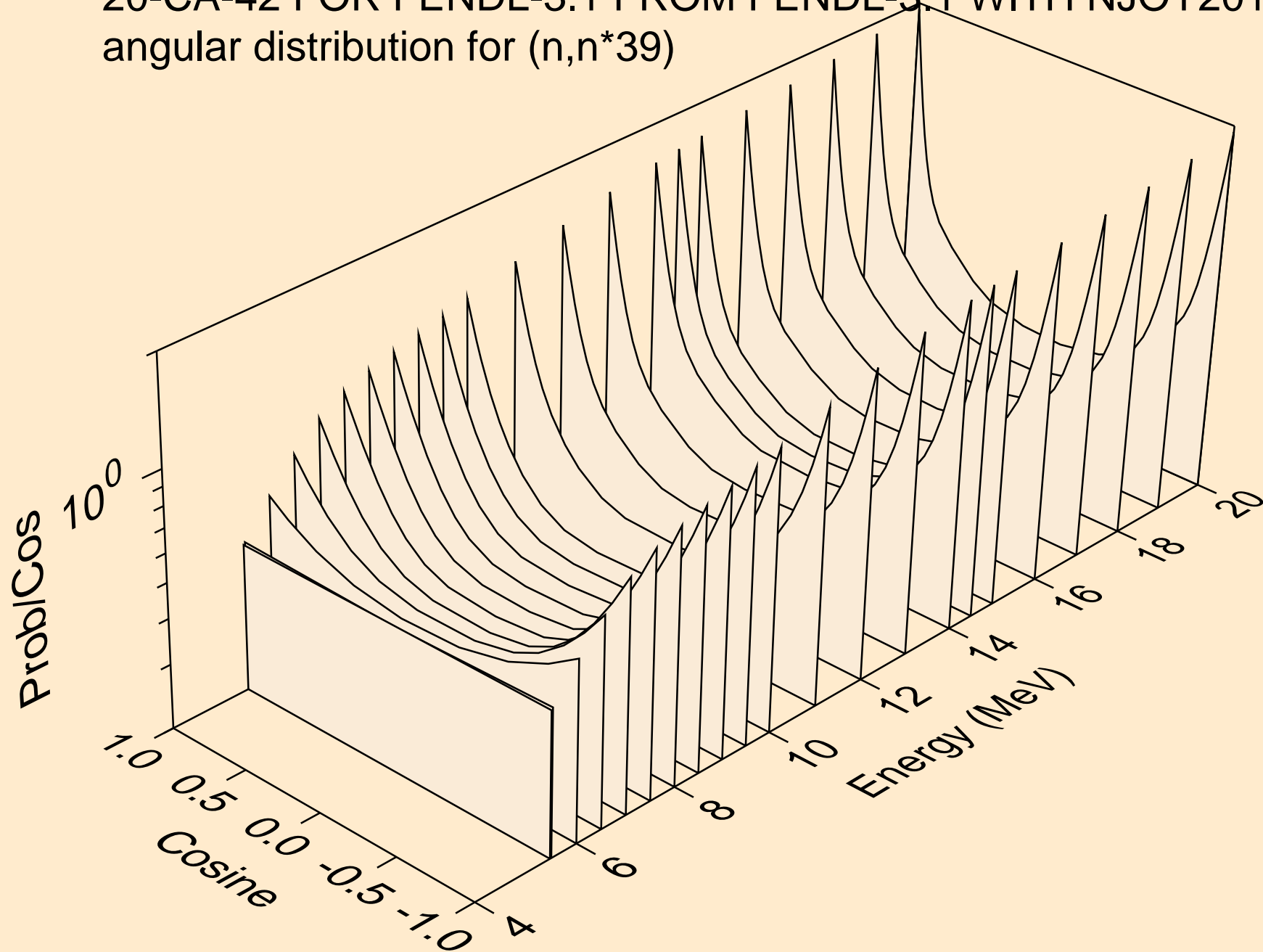

20-CA-42 FOR FENDL-3.1 FROM FENDL-3.1 WITH NJOY2012.50+  
Neutron emission for (n,x)

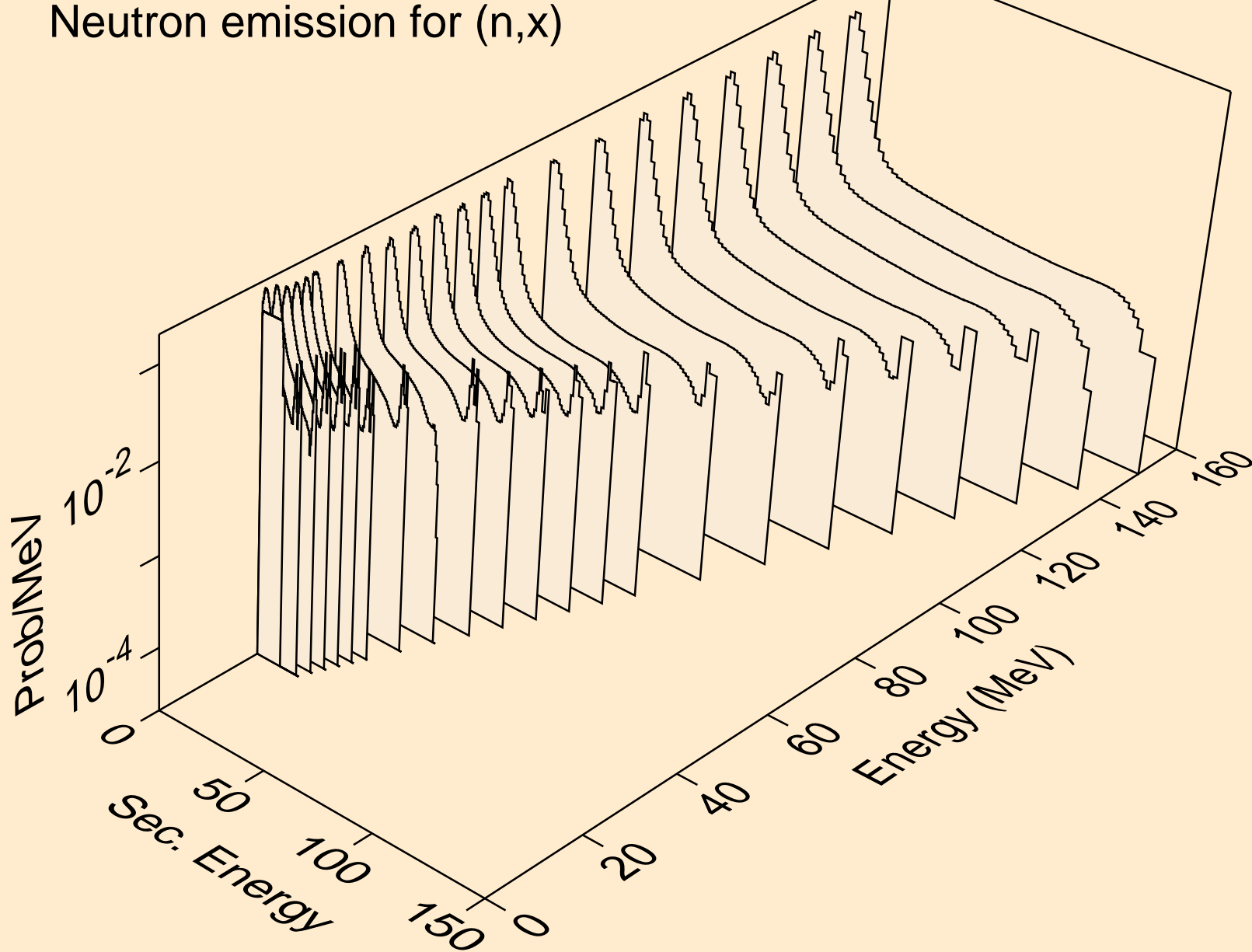

20-CA-42 FOR FENDL-3.1 FROM FENDL-3.1 WITH NJOY2012.50+  
Neutron emission for (n,2n)

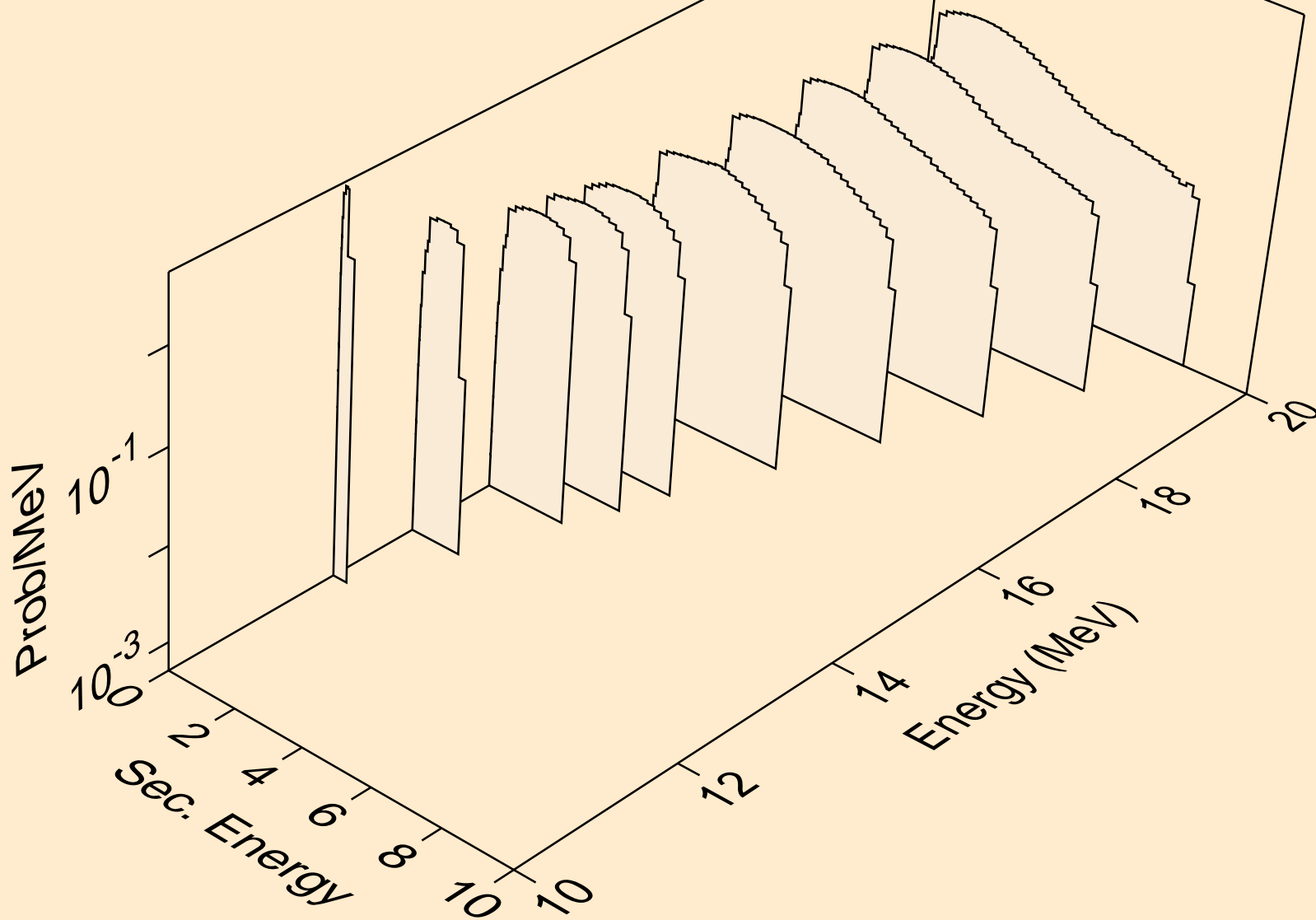

20-CA-42 FOR FENDL-3.1 FROM FENDL-3.1 WITH NJOY2012.50+  
Neutron emission for (n,n\*)a

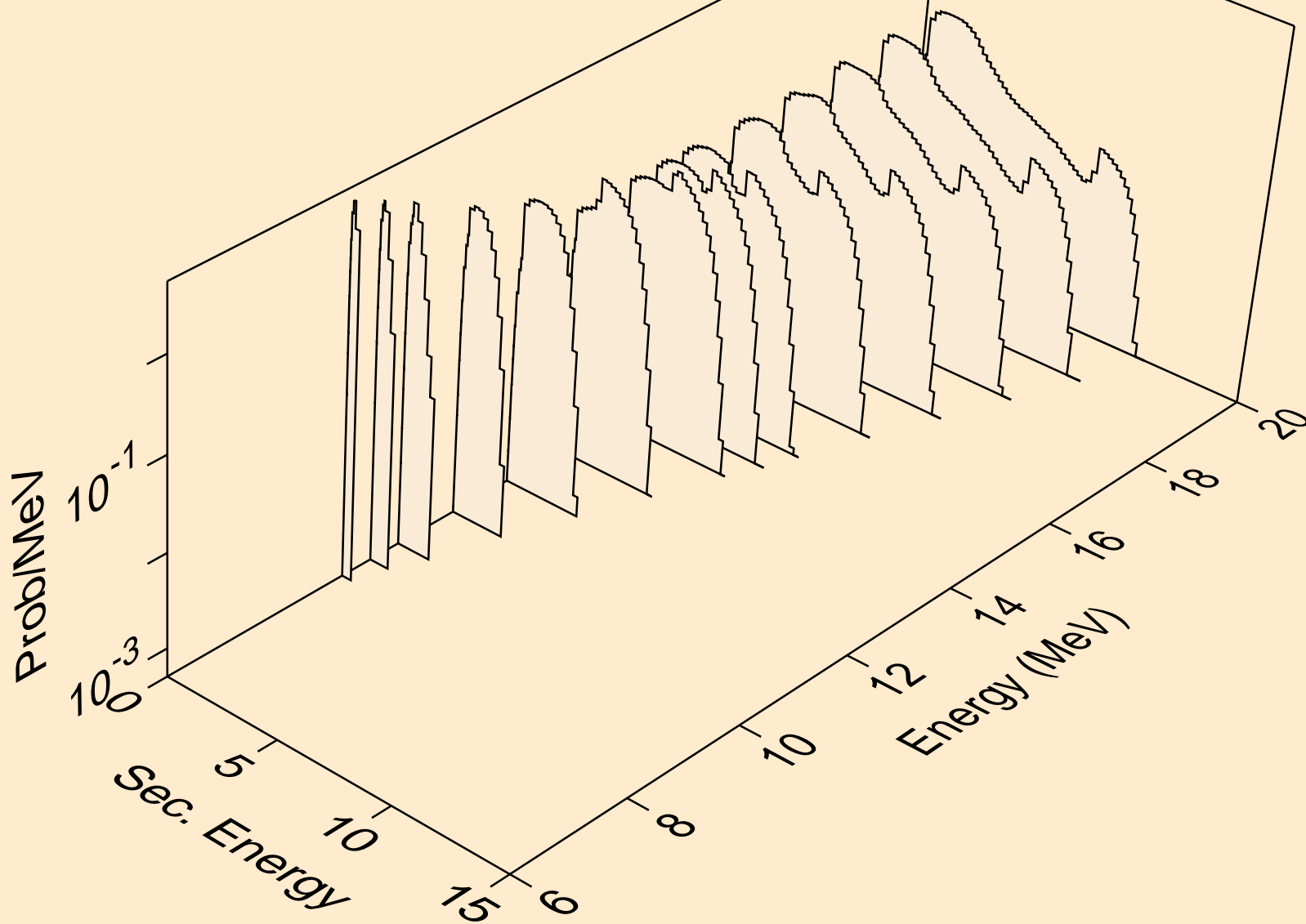

20-CA-42 FOR FENDL-3.1 FROM FENDL-3.1 WITH NJOY2012.50+  
Neutron emission for (n,n\*)p

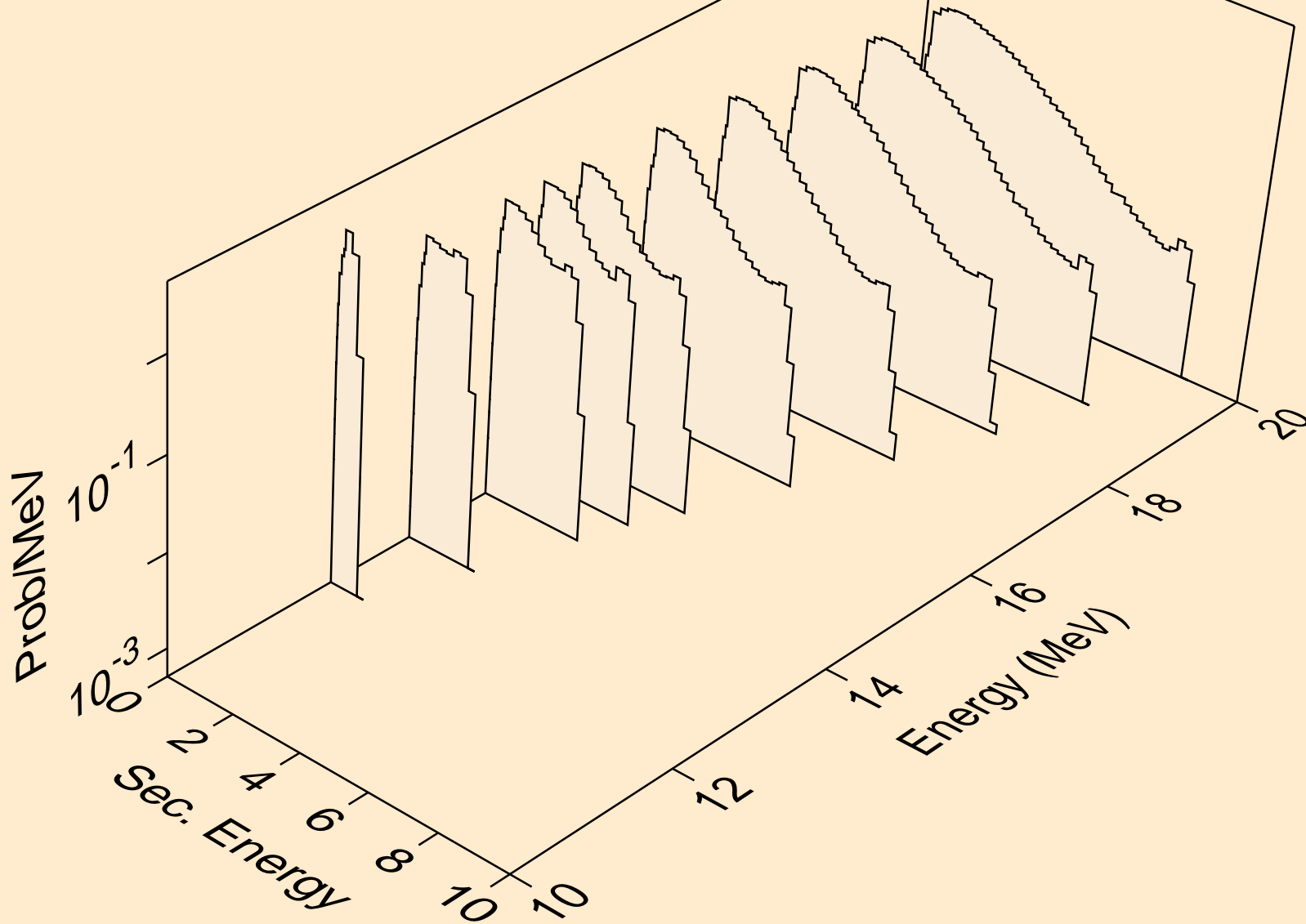

20-CA-42 FOR FENDL-3.1 FROM FENDL-3.1 WITH NJOY2012.50+  
Neutron emission for (n,n\*c)

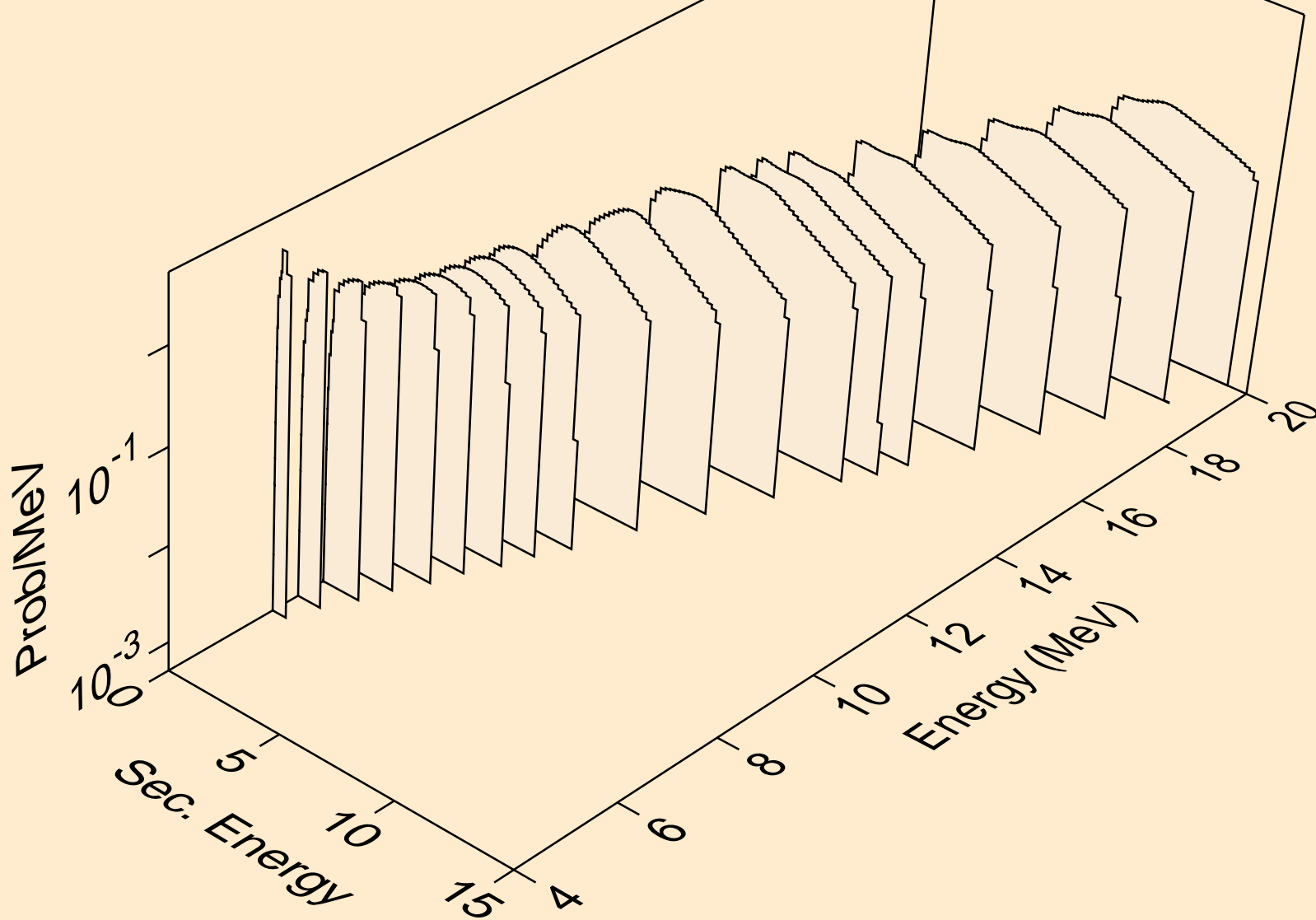



20-CA-42 FOR FENDL-3.1 FROM FENDL-3.1 WITH NJOY2012.50+  
Photon emission for (n,x)

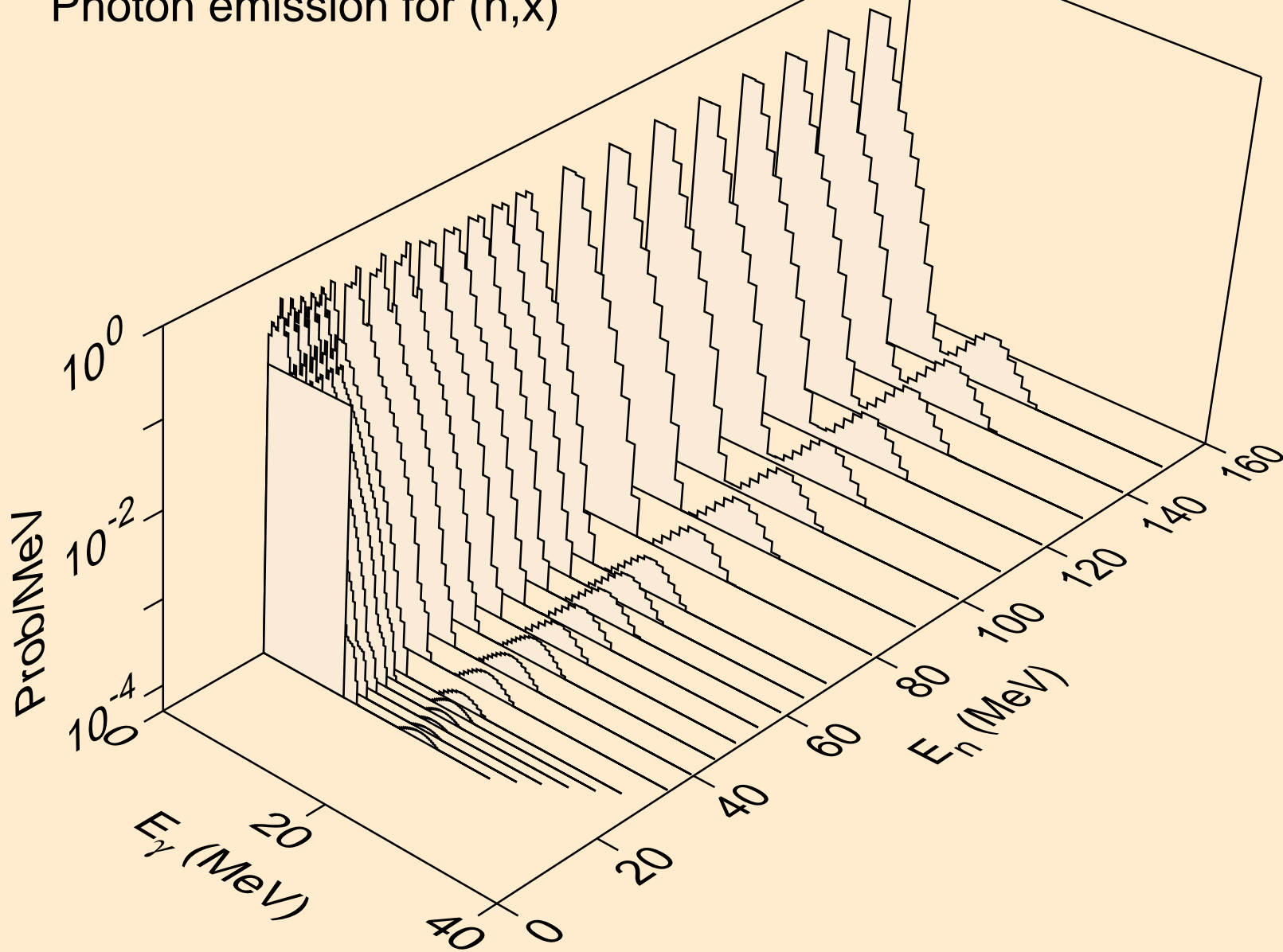

20-CA-42 FOR FENDL-3.1 FROM FENDL-3.1 WITH NJOY2012.50+  
Photon emission for (n,2n)

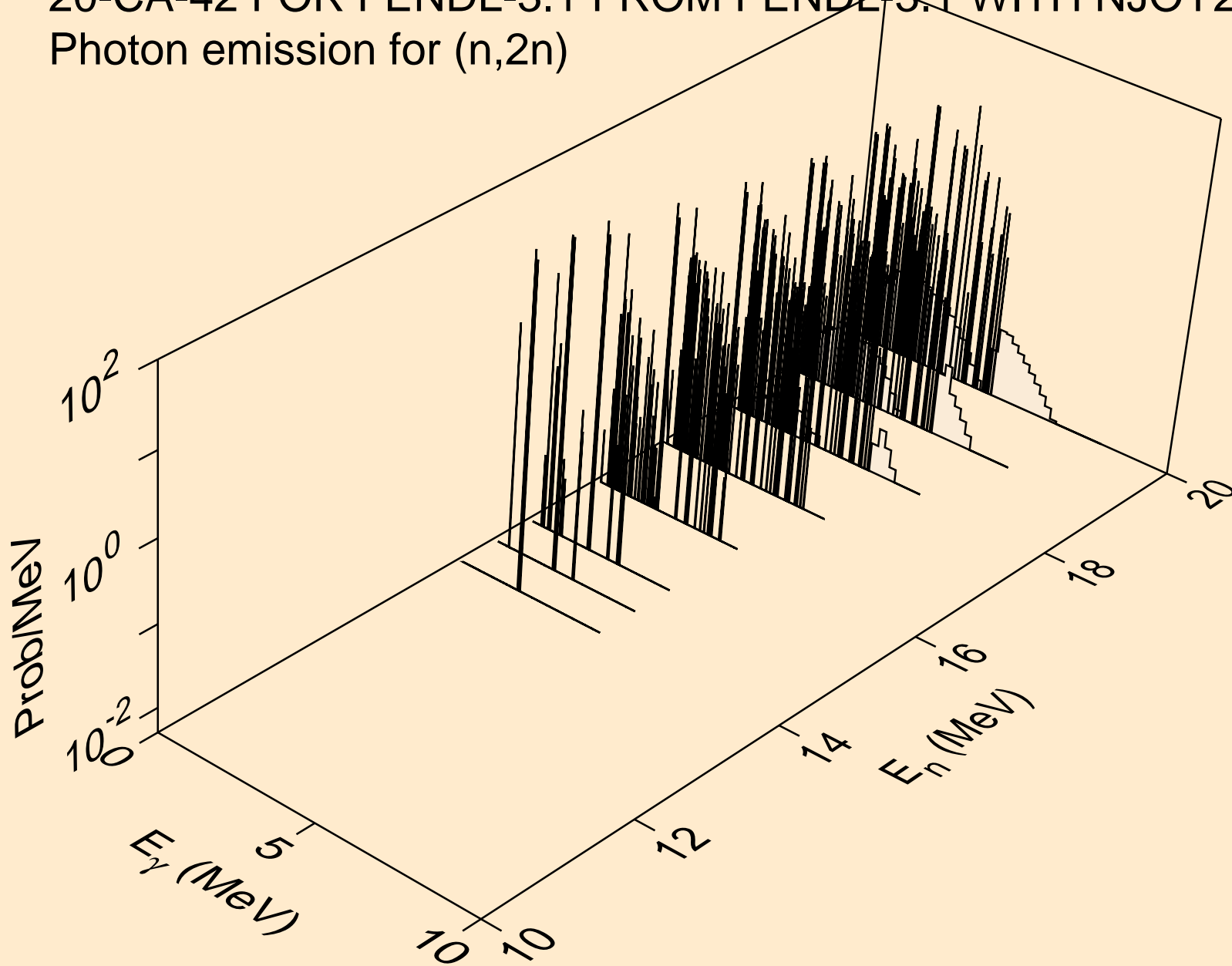

20-CA-42 FOR FENDL-3.1 FROM FENDL-3.1 WITH NJOY2012.50+  
Photon emission for (n,n\*)a

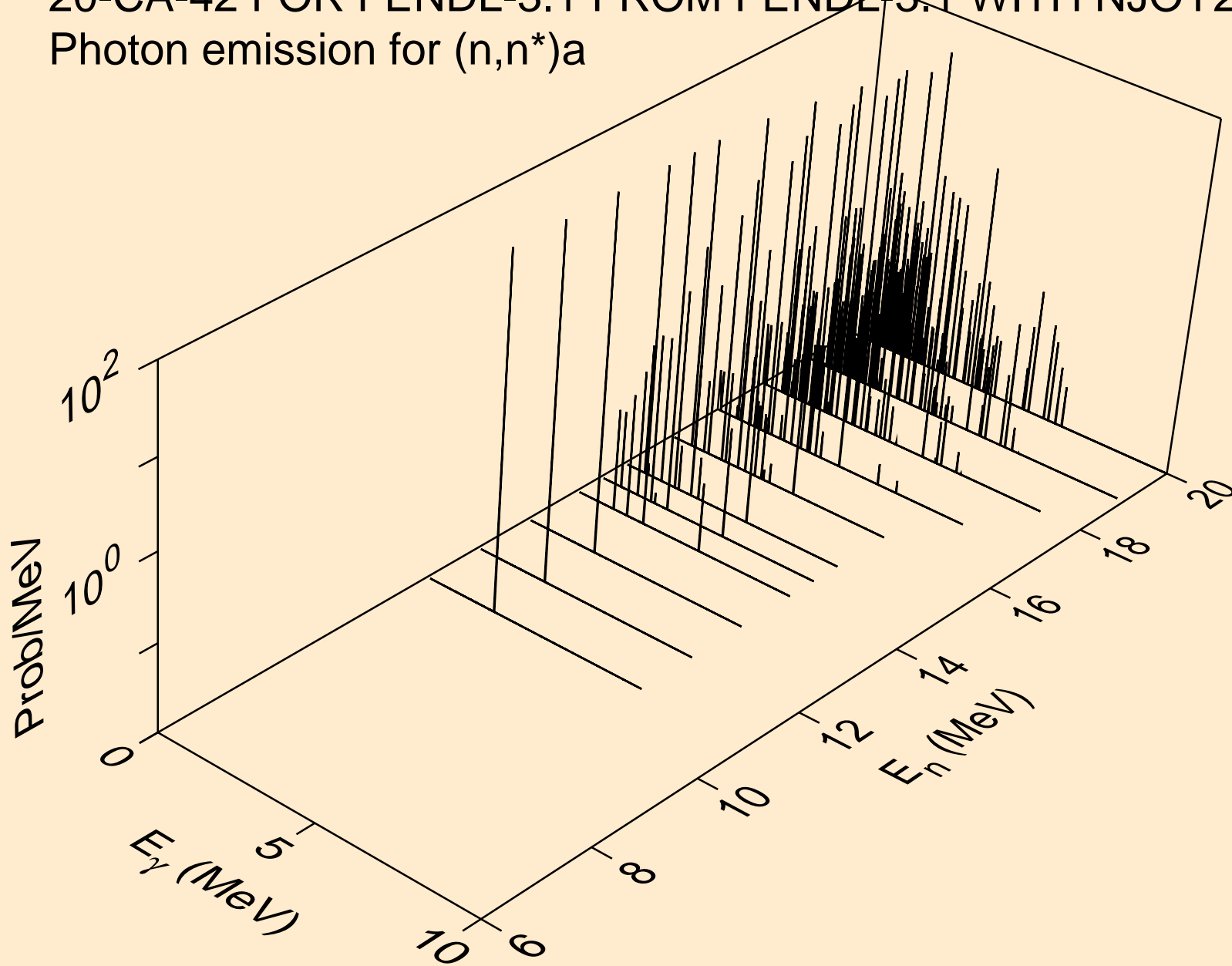

20-CA-42 FOR FENDL-3.1 FROM FENDL-3.1 WITH NJOY2012.50+  
Photon emission for (n,n\*)p

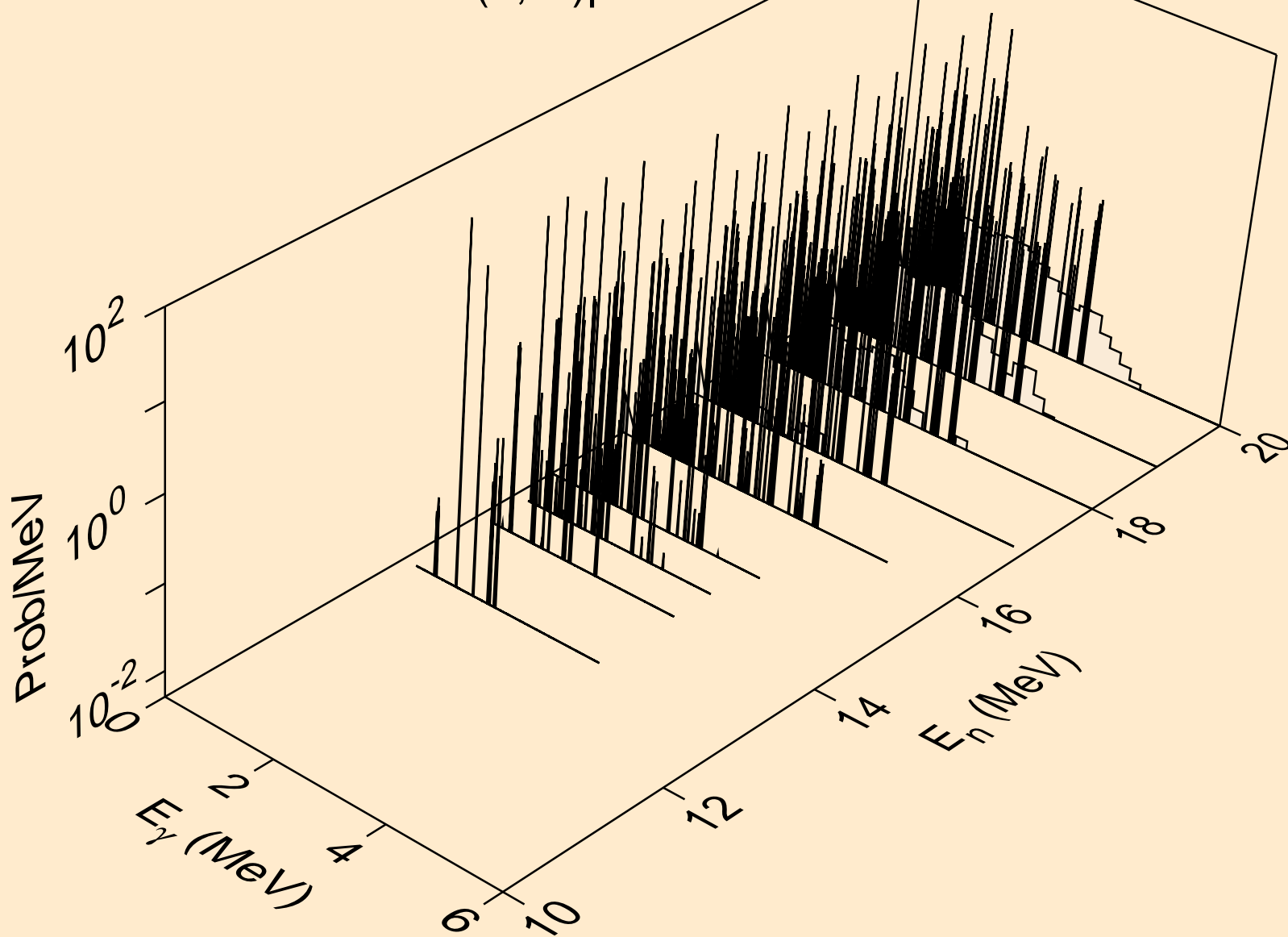

20-CA-42 FOR FENDL-3.1 FROM FENDL-3.1 WITH NJOY2012.50+  
Photon emission for (n,n\*1)

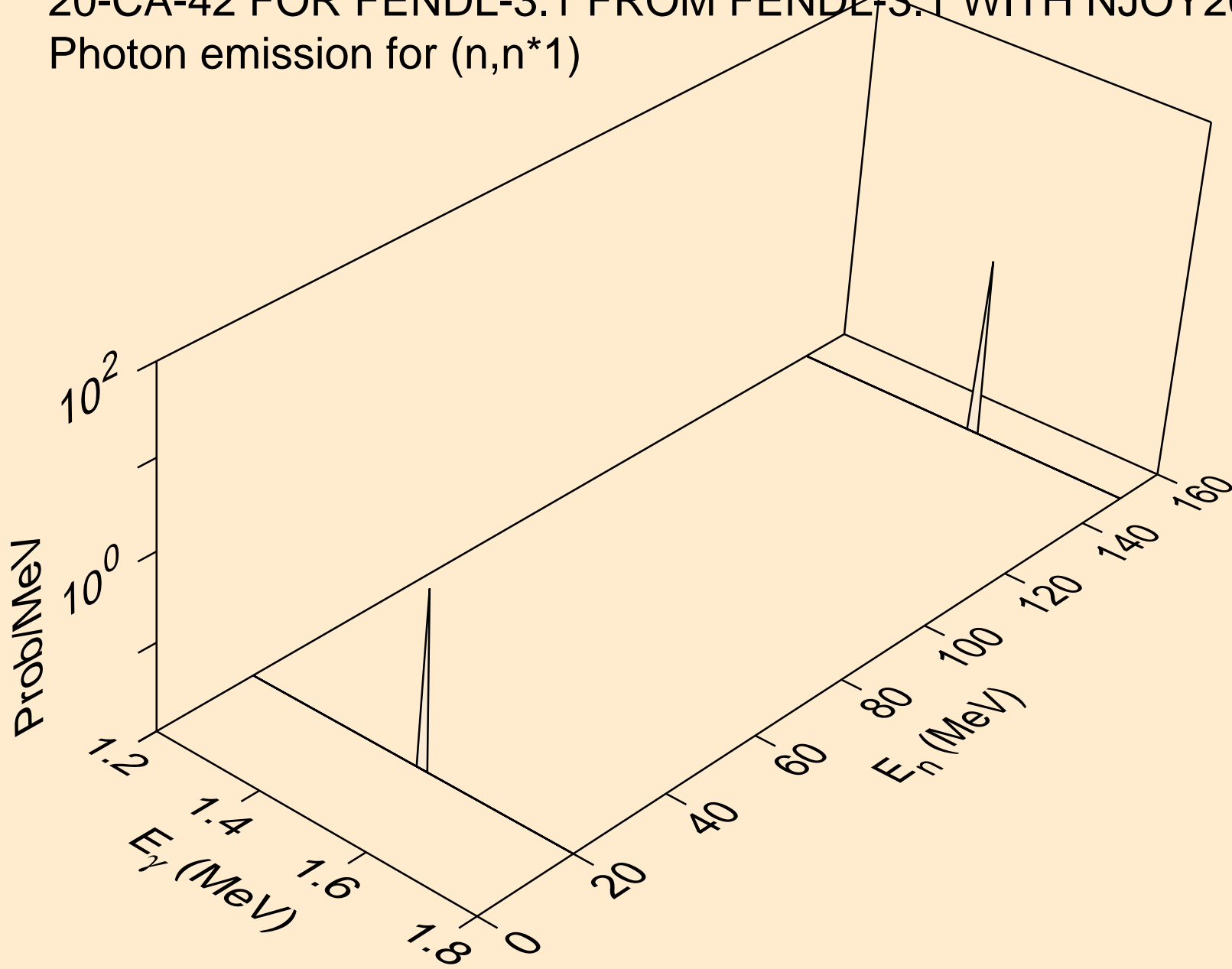

20-CA-42 FOR FENDL-3.1 FROM FENDL-3.1 WITH NJOY2012.50+  
Photon emission for (n,n\*2)

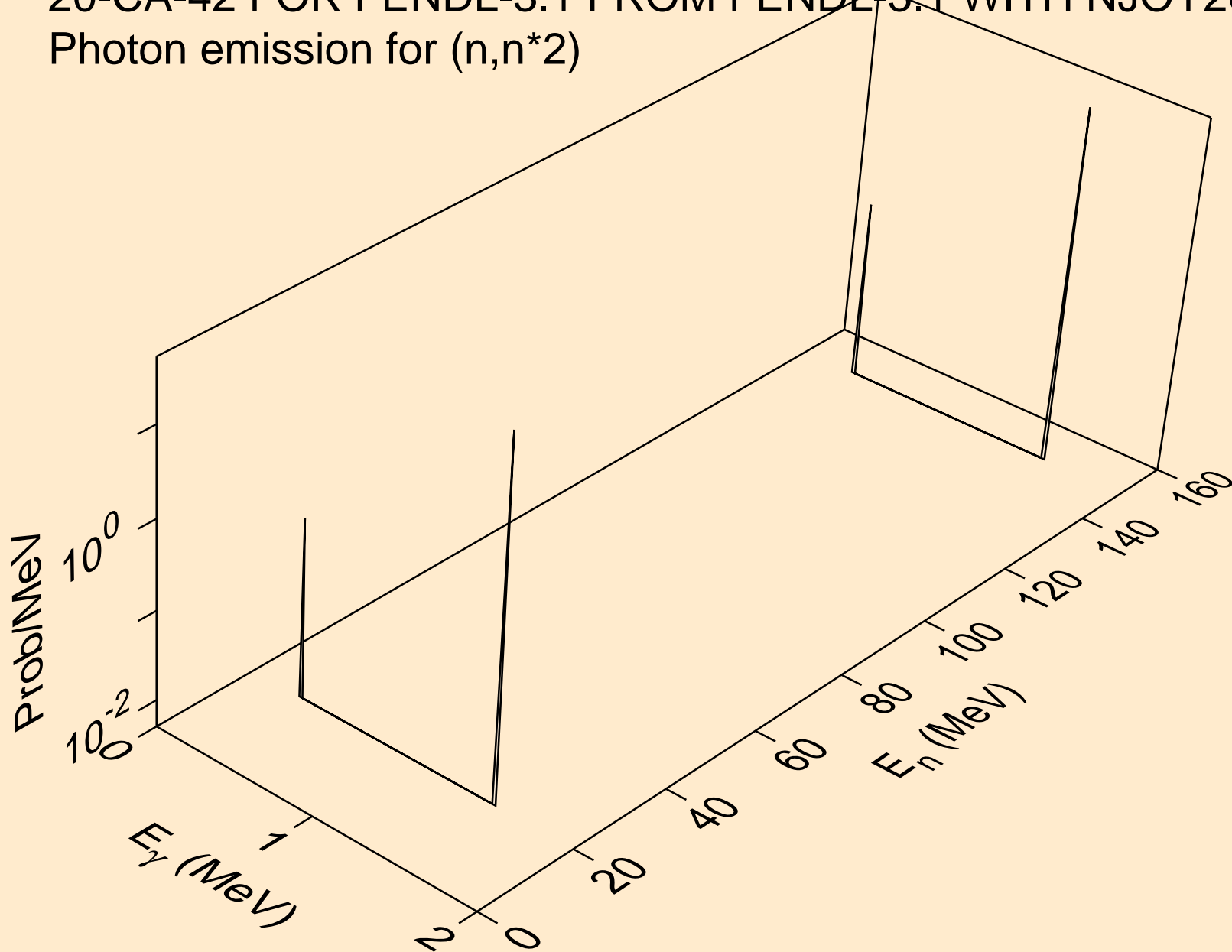

20-CA-42 FOR FENDL-3.1 FROM FENDL-3.1 WITH NJOY2012.50+  
Photon emission for (n,n\*3)

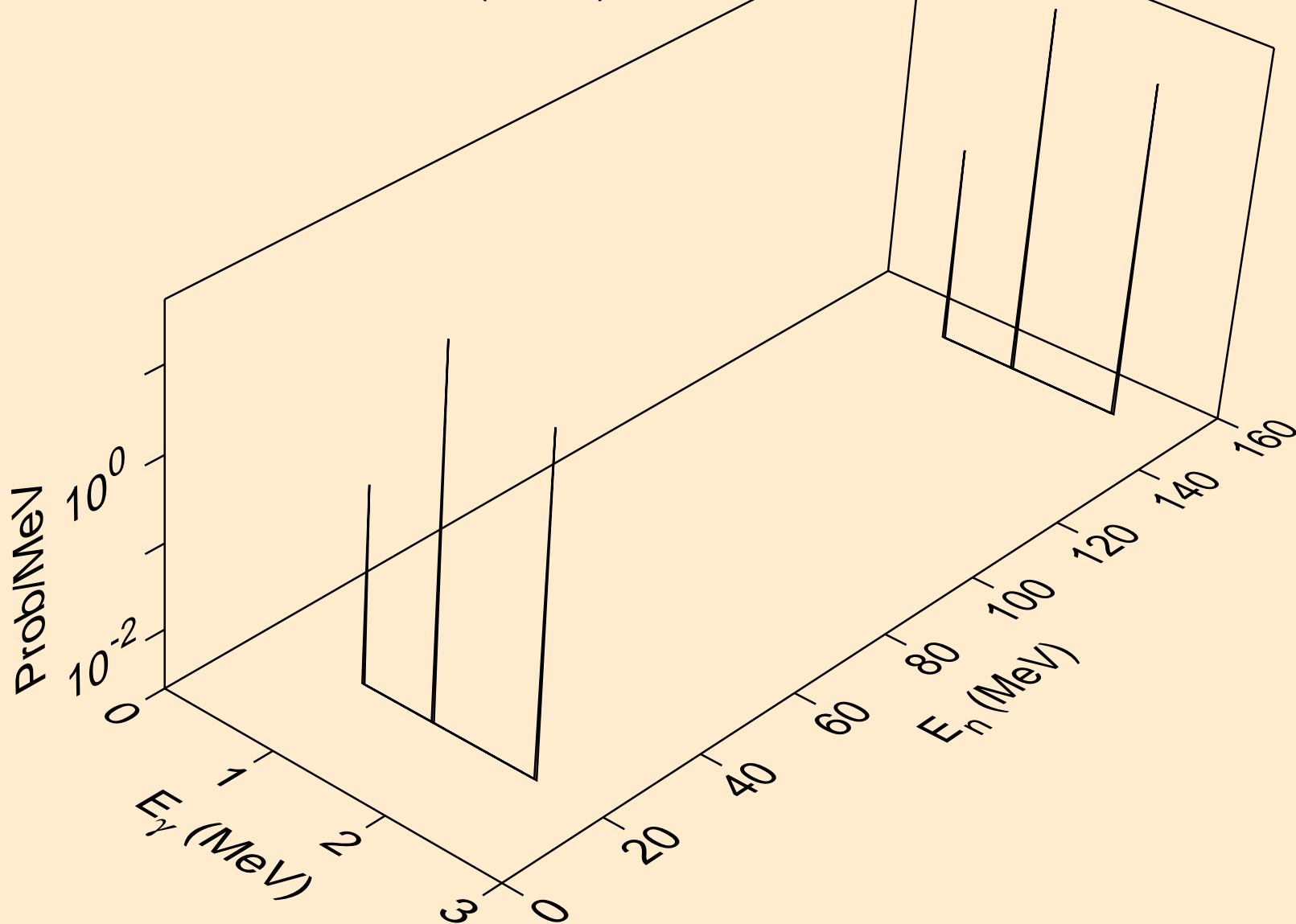

20-CA-42 FOR FENDL-3.1 FROM FENDL-3.1 WITH NJOY2012.50+  
Photon emission for (n,n\*4)

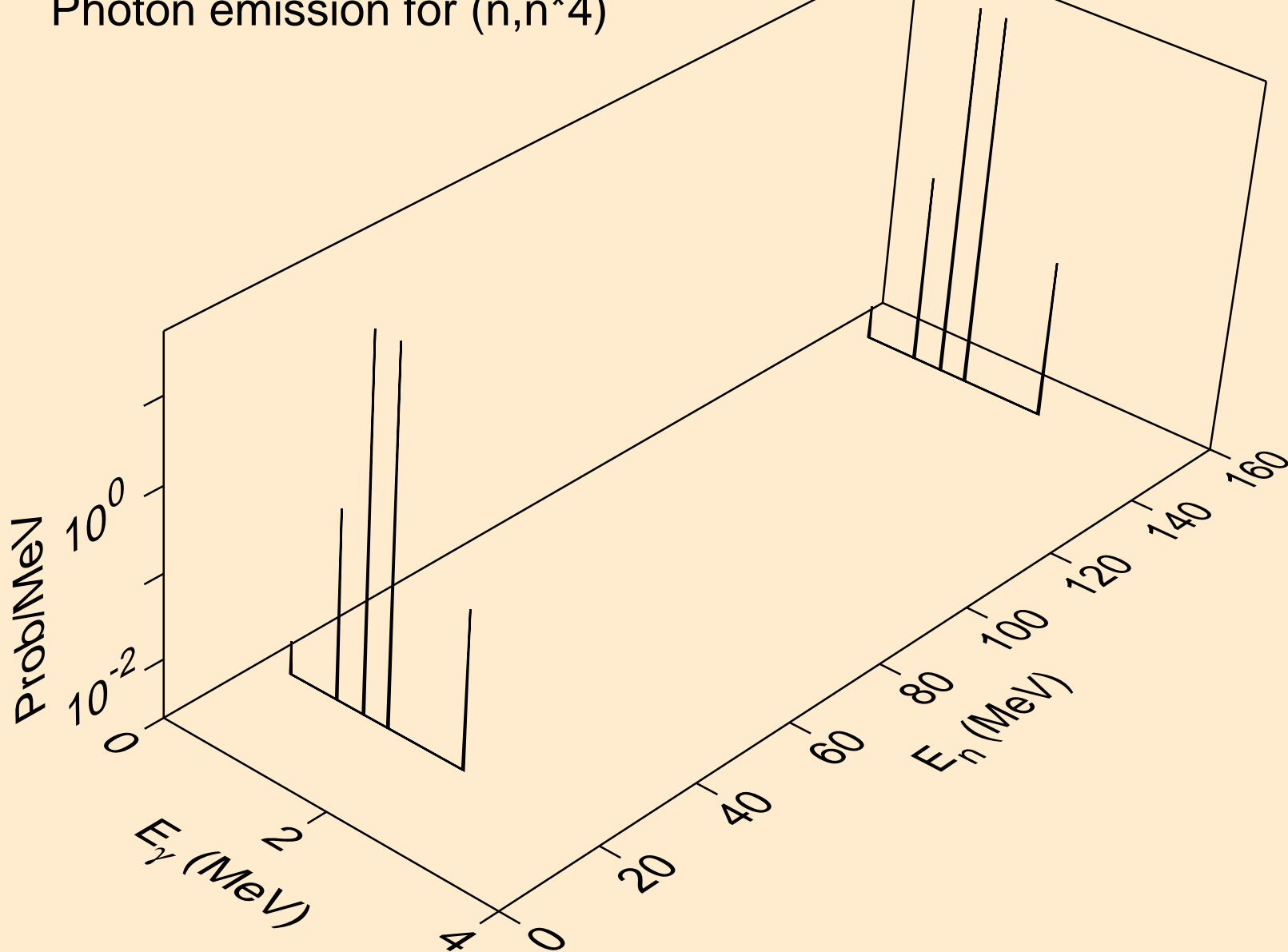



20-CA-42 FOR FENDL-3.1 FROM FENDL-3.1 WITH NJOY2012.50+  
Photon emission for (n,n\*5)

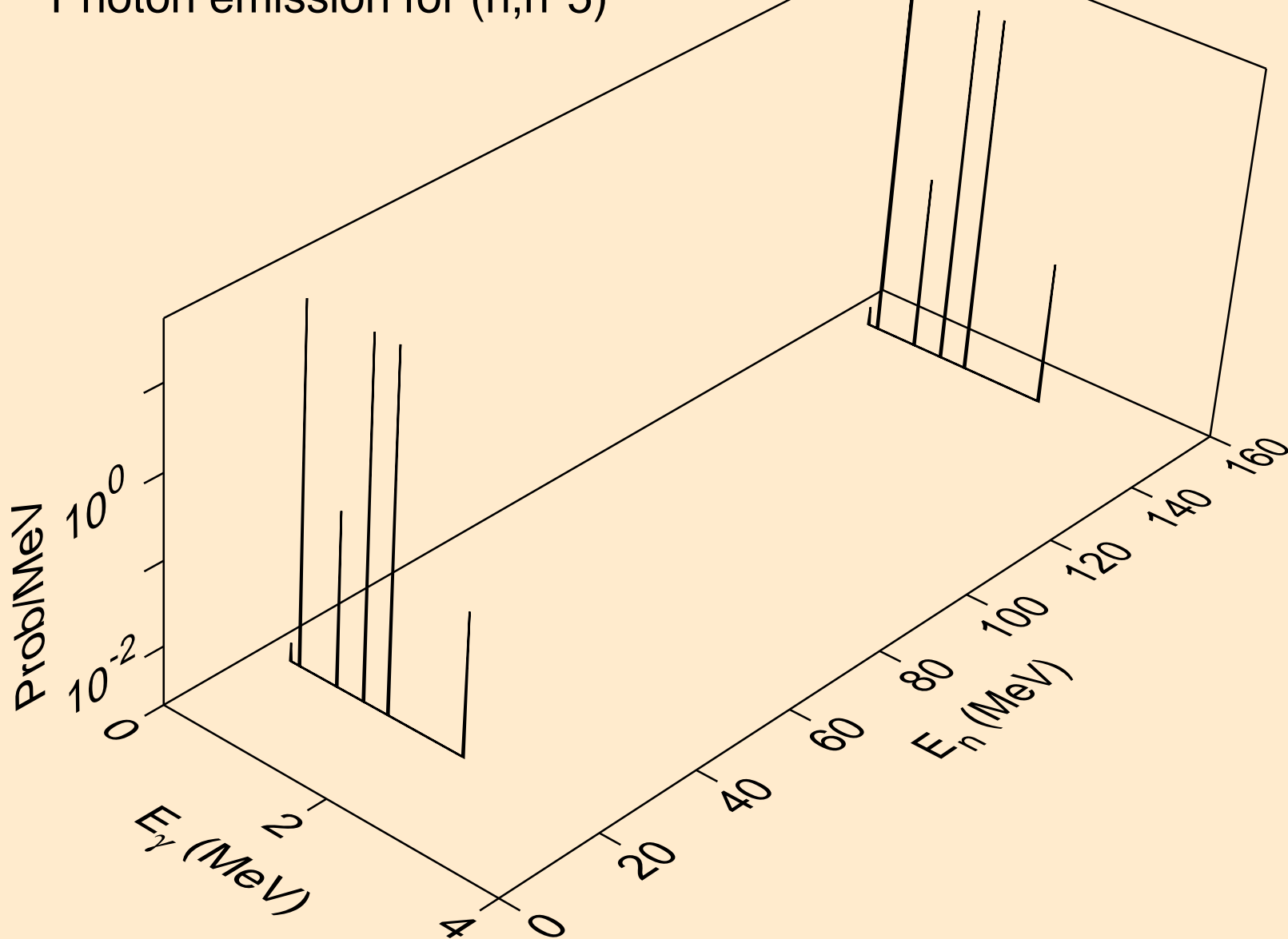

20-CA-42 FOR FENDL-3.1 FROM FENDL-3.1 WITH NJOY2012.50+  
Photon emission for (n,n\*6)

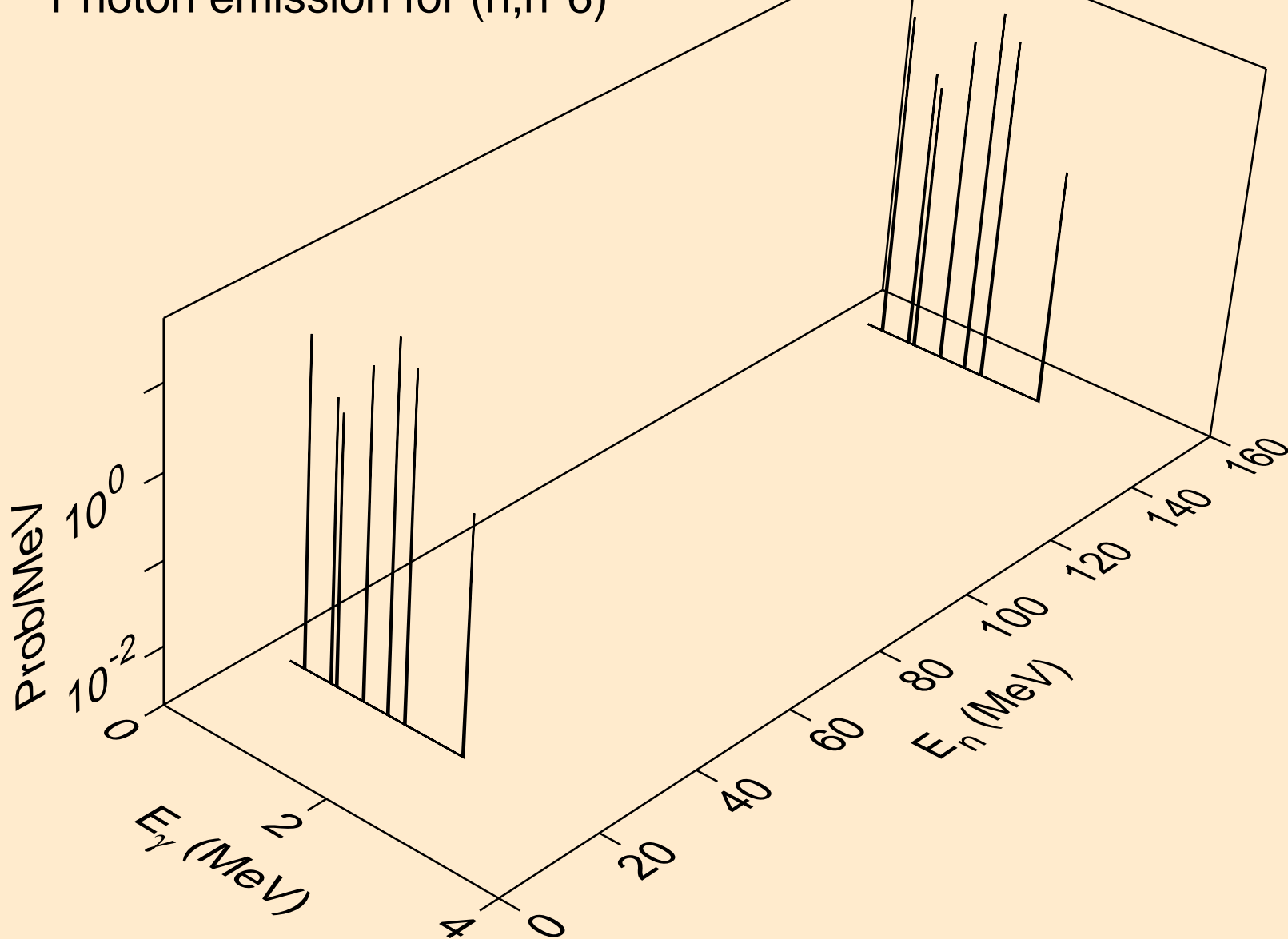

20-CA-42 FOR FENDL-3.1 FROM FENDL-3.1 WITH NJOY2012.50+  
Photon emission for (n,n\*7)

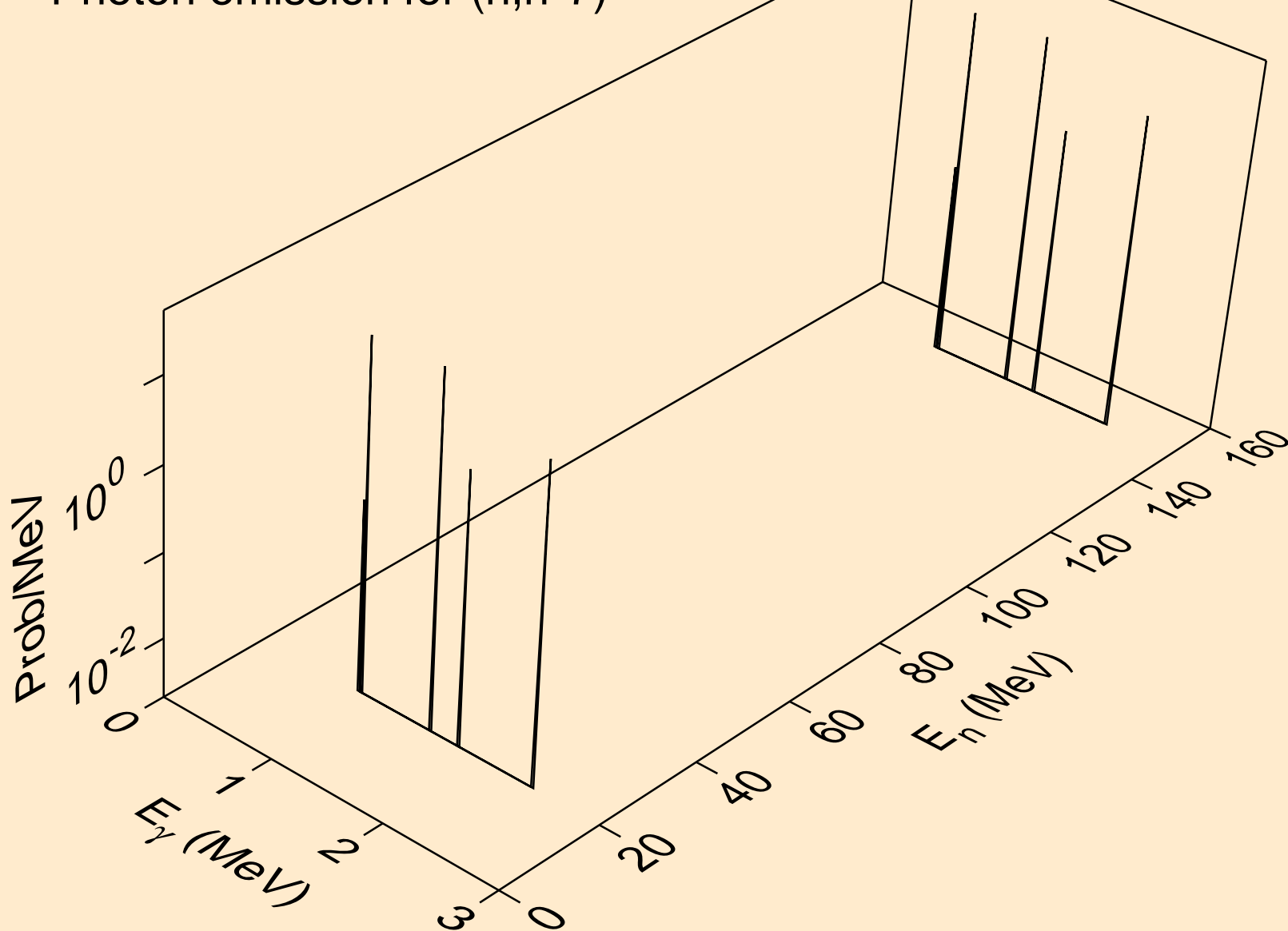

20-CA-42 FOR FENDL-3.1 FROM FENDL-3.1 WITH NJOY2012.50+  
Photon emission for (n,n\*8)

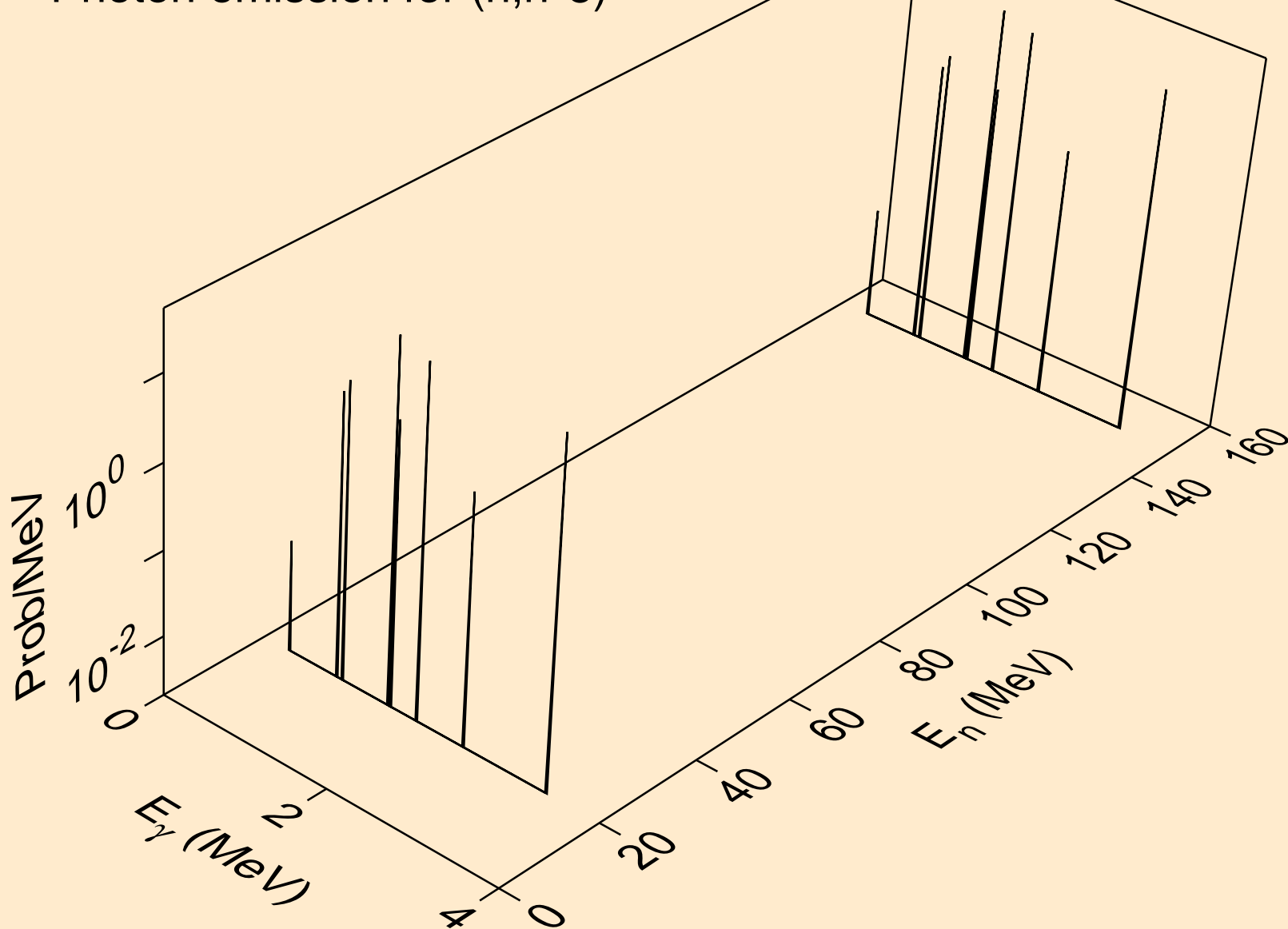

20-CA-42 FOR FENDL-3.1 FROM FENDL-3.1 WITH NJOY2012.50+  
Photon emission for (n,n\*9)

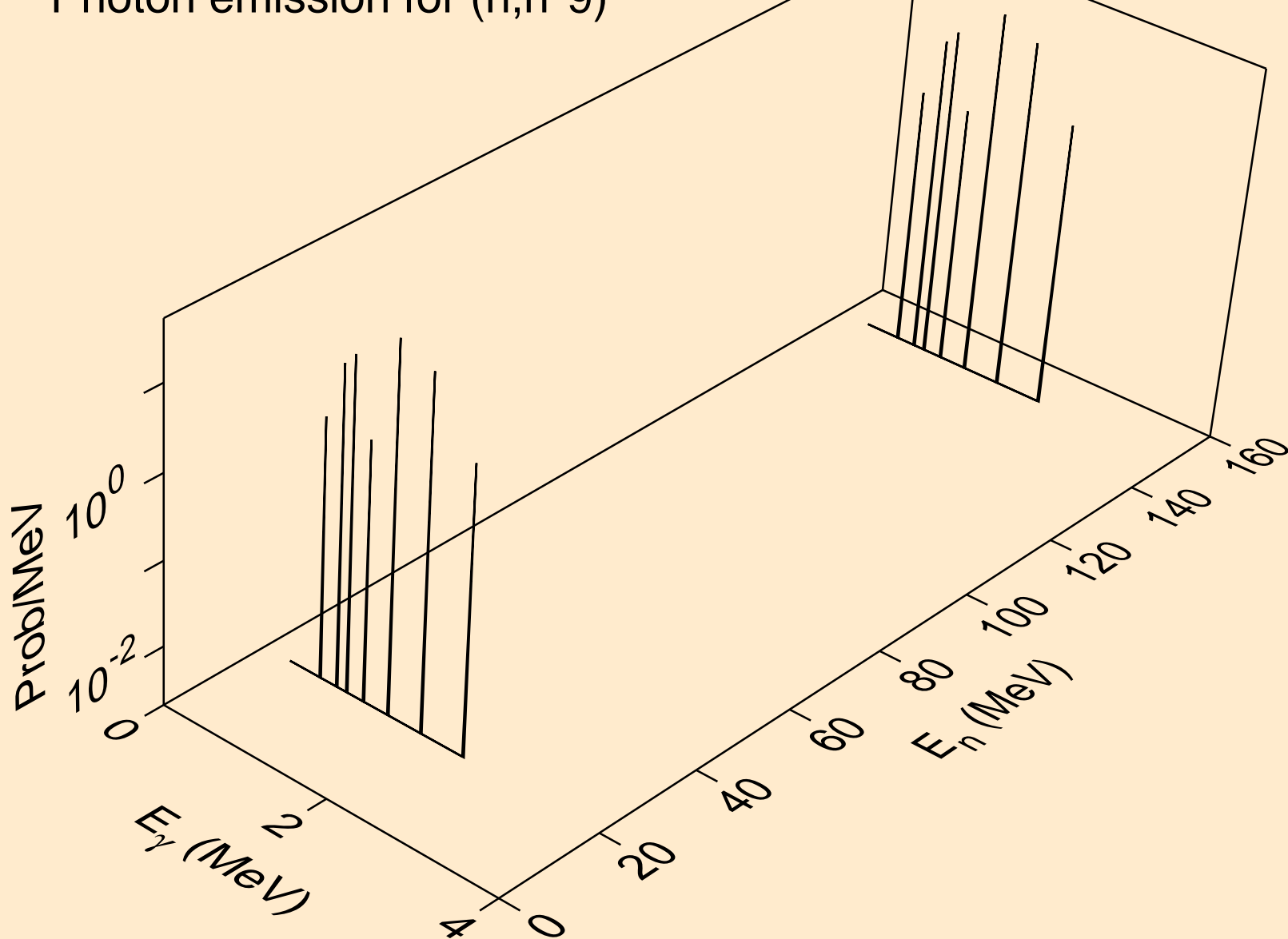

20-CA-42 FOR FENDL-3.1 FROM FENDL-3.1 WITH NJOY2012.50+  
Photon emission for (n,n\*10)

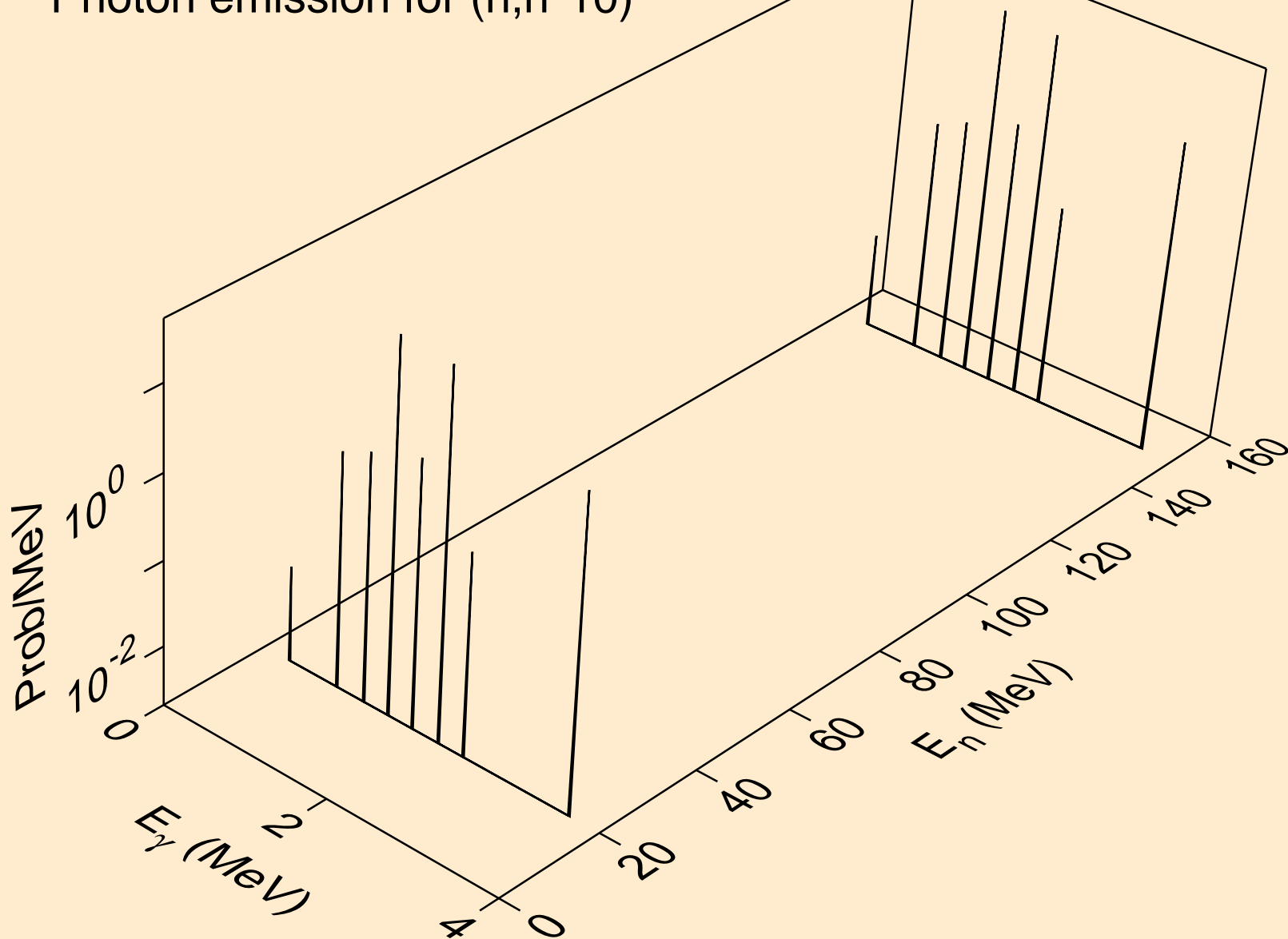

20-CA-42 FOR FENDL-3.1 FROM FENDL-3.1 WITH NJOY2012.50+  
Photon emission for (n,n\*11)

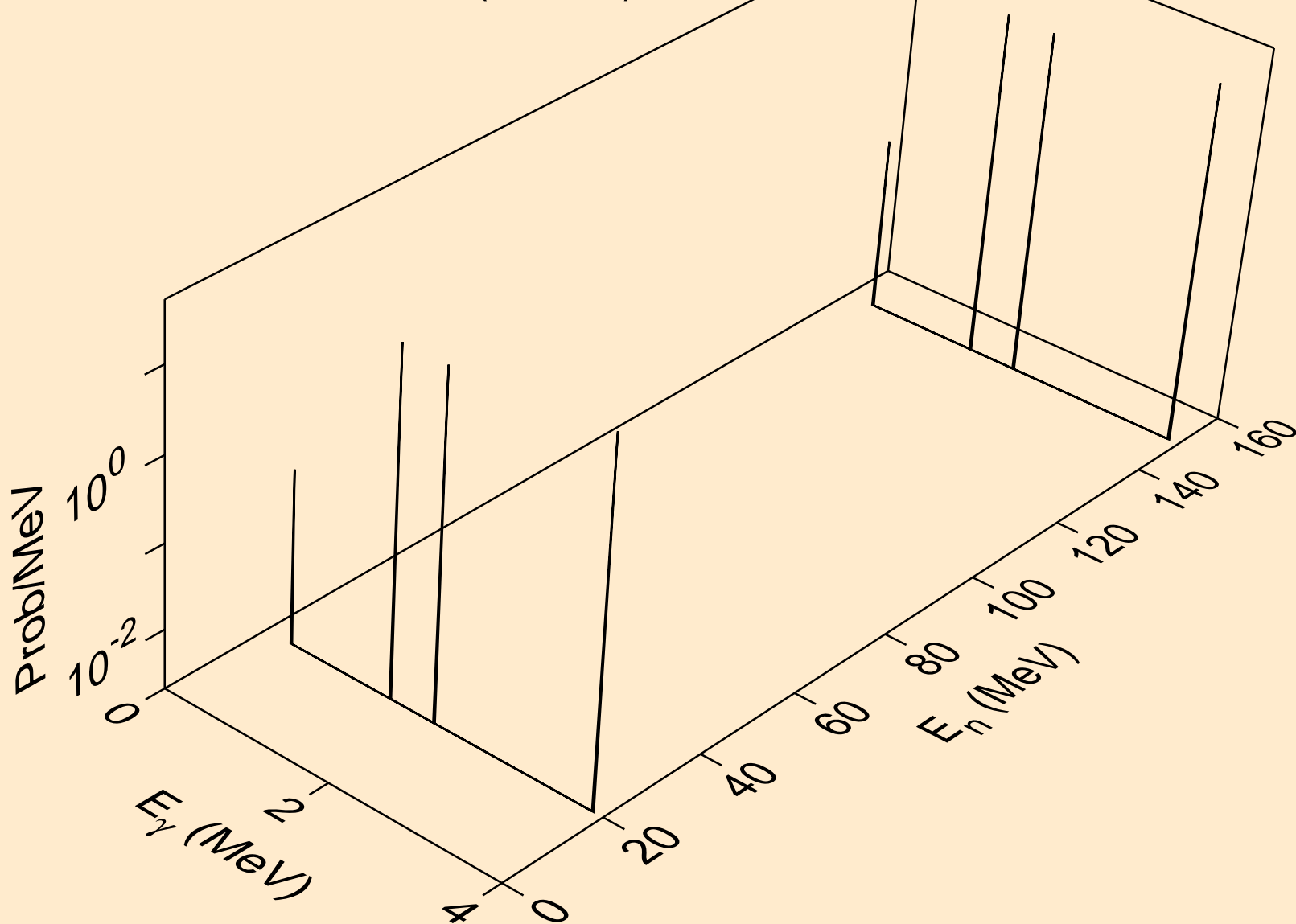

20-CA-42 FOR FENDL-3.1 FROM FENDL-3.1 WITH NJOY2012.50+  
Photon emission for (n,n\*12)

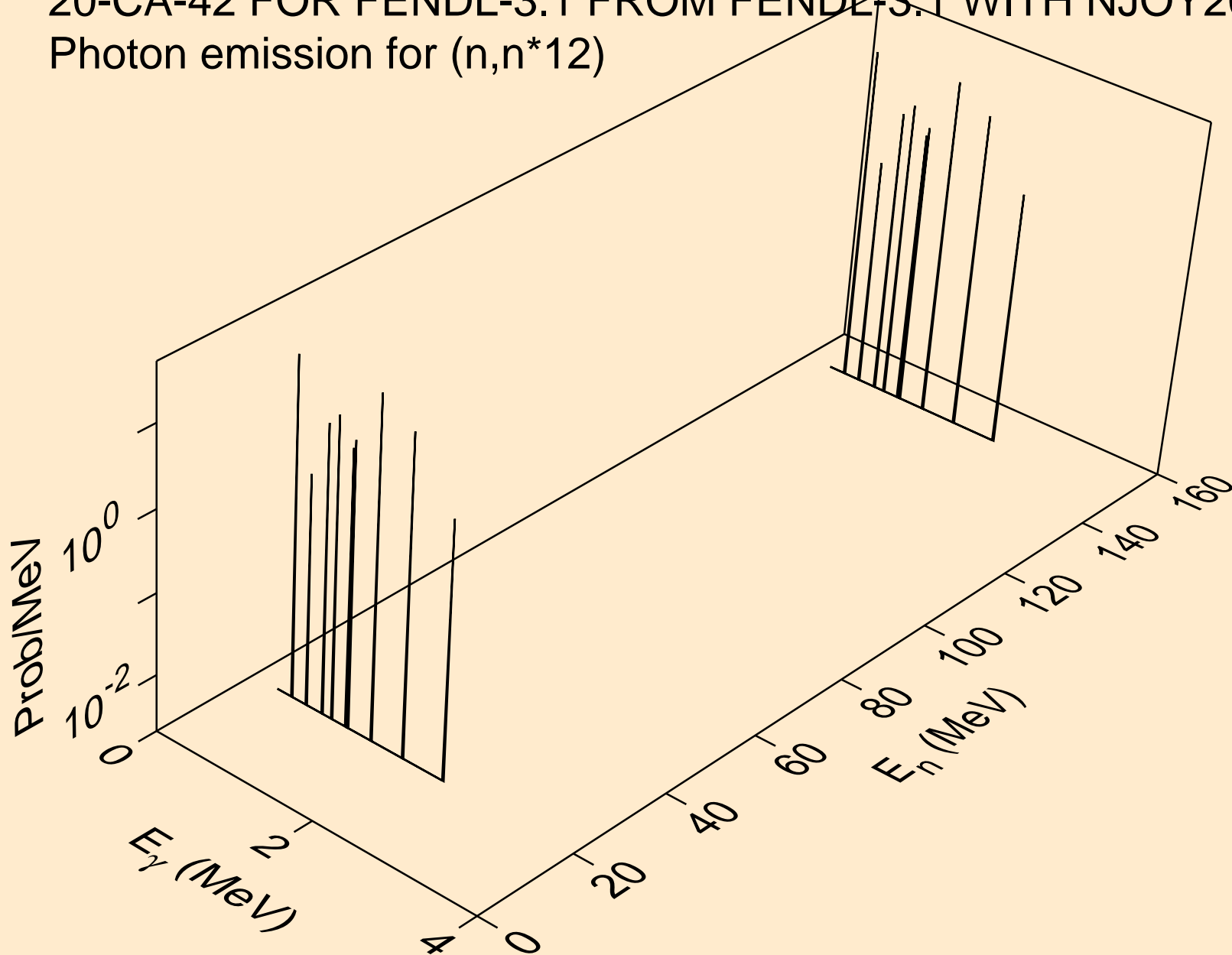



20-CA-42 FOR FENDL-3.1 FROM FENDL-3.1 WITH NJOY2012.50+  
Photon emission for (n,n\*13)

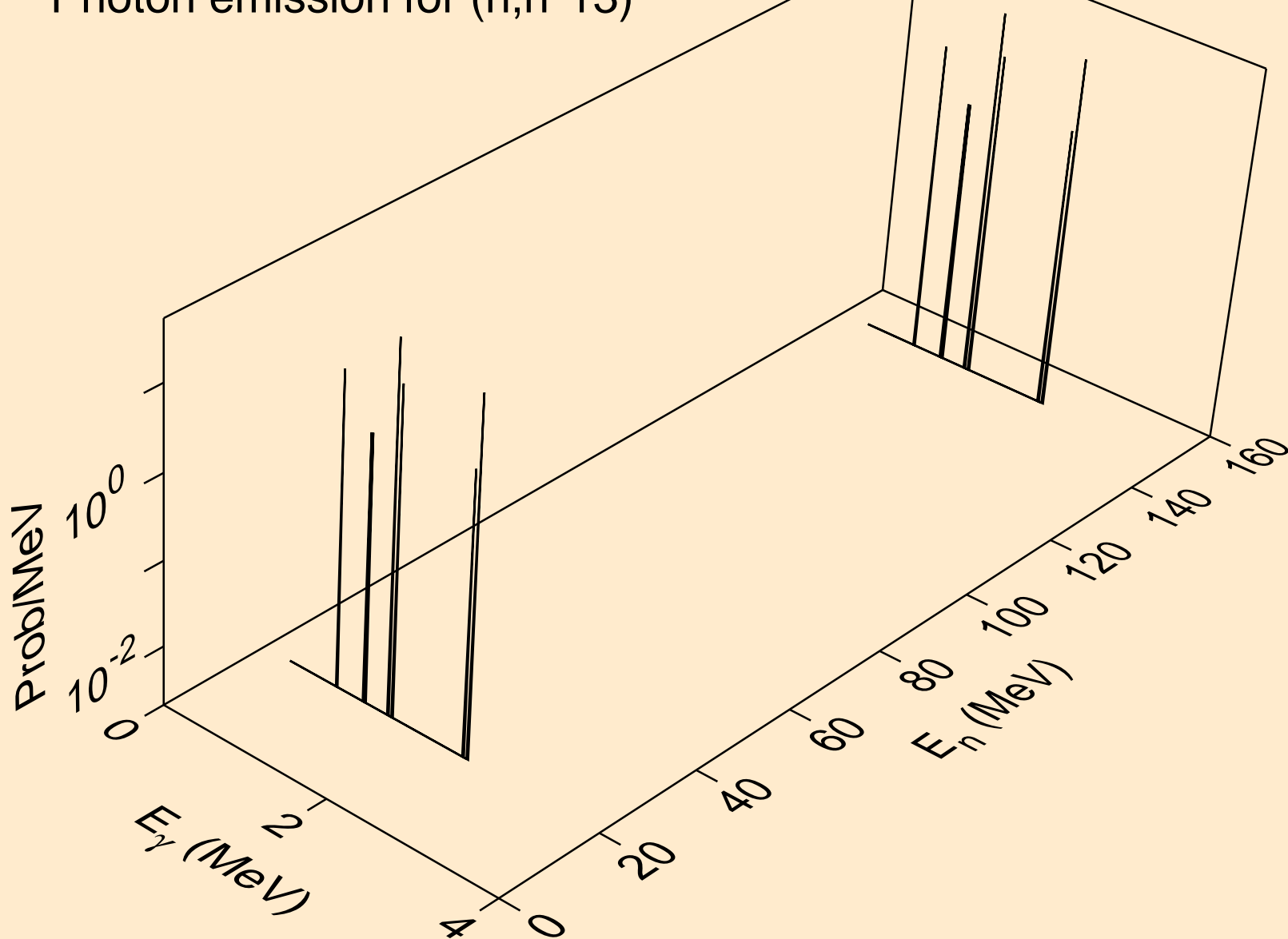

20-CA-42 FOR FENDL-3.1 FROM FENDL-3.1 WITH NJOY2012.50+  
Photon emission for (n,n\*14)

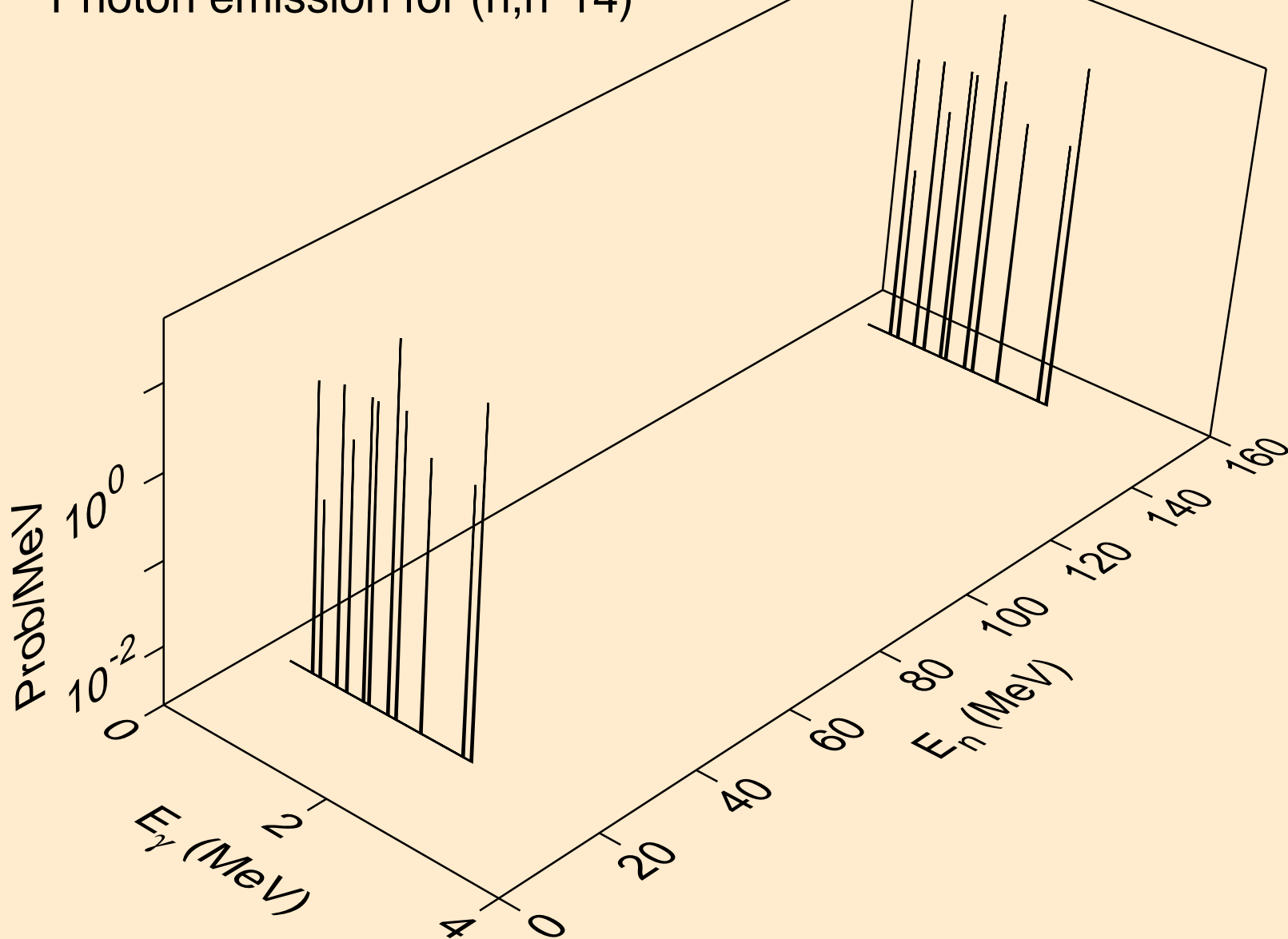

20-CA-42 FOR FENDL-3.1 FROM FENDL-3.1 WITH NJOY2012.50+  
Photon emission for (n,n\*15)

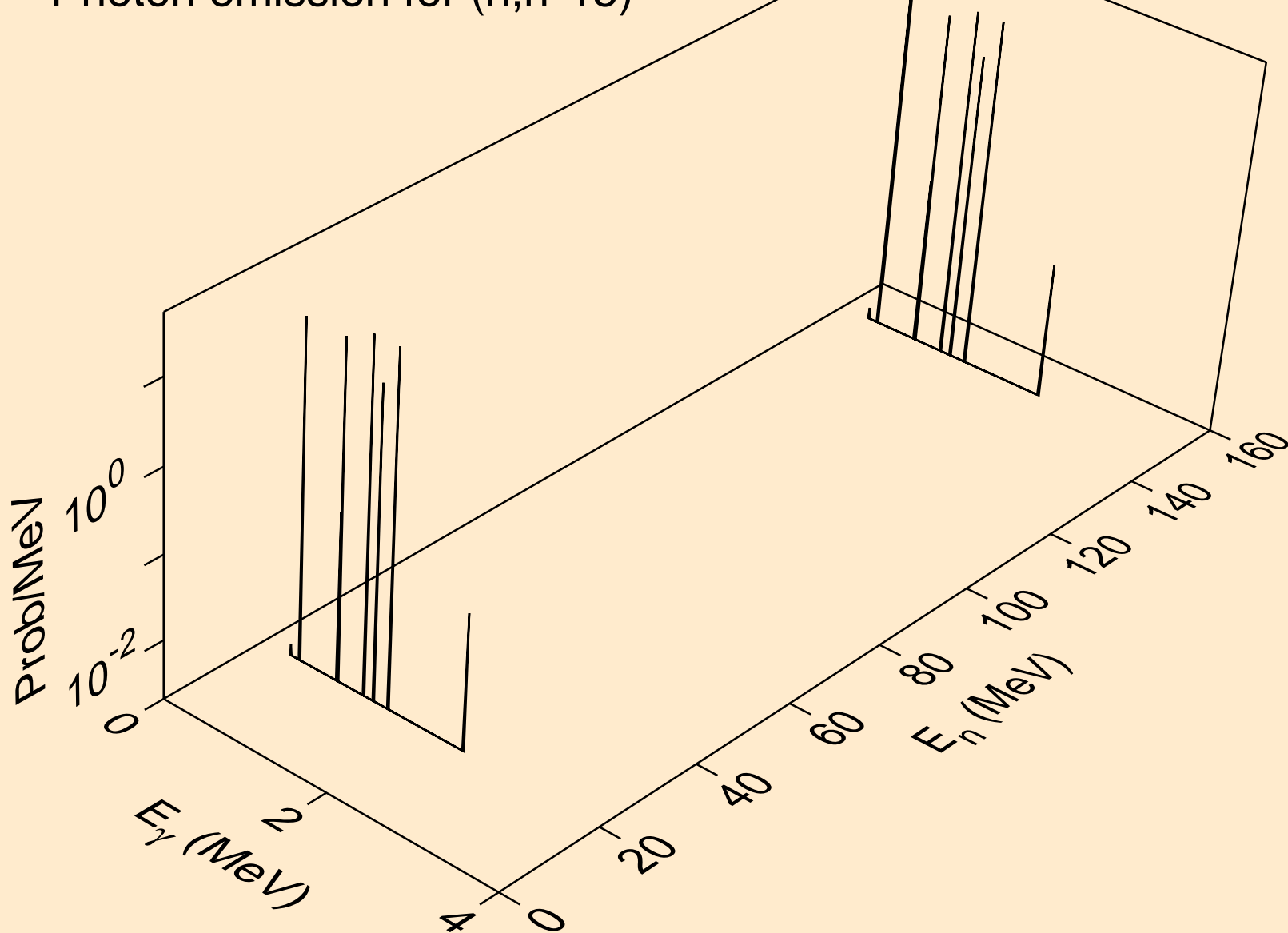

20-CA-42 FOR FENDL-3.1 FROM FENDL-3.1 WITH NJOY2012.50+  
Photon emission for (n,n\*16)

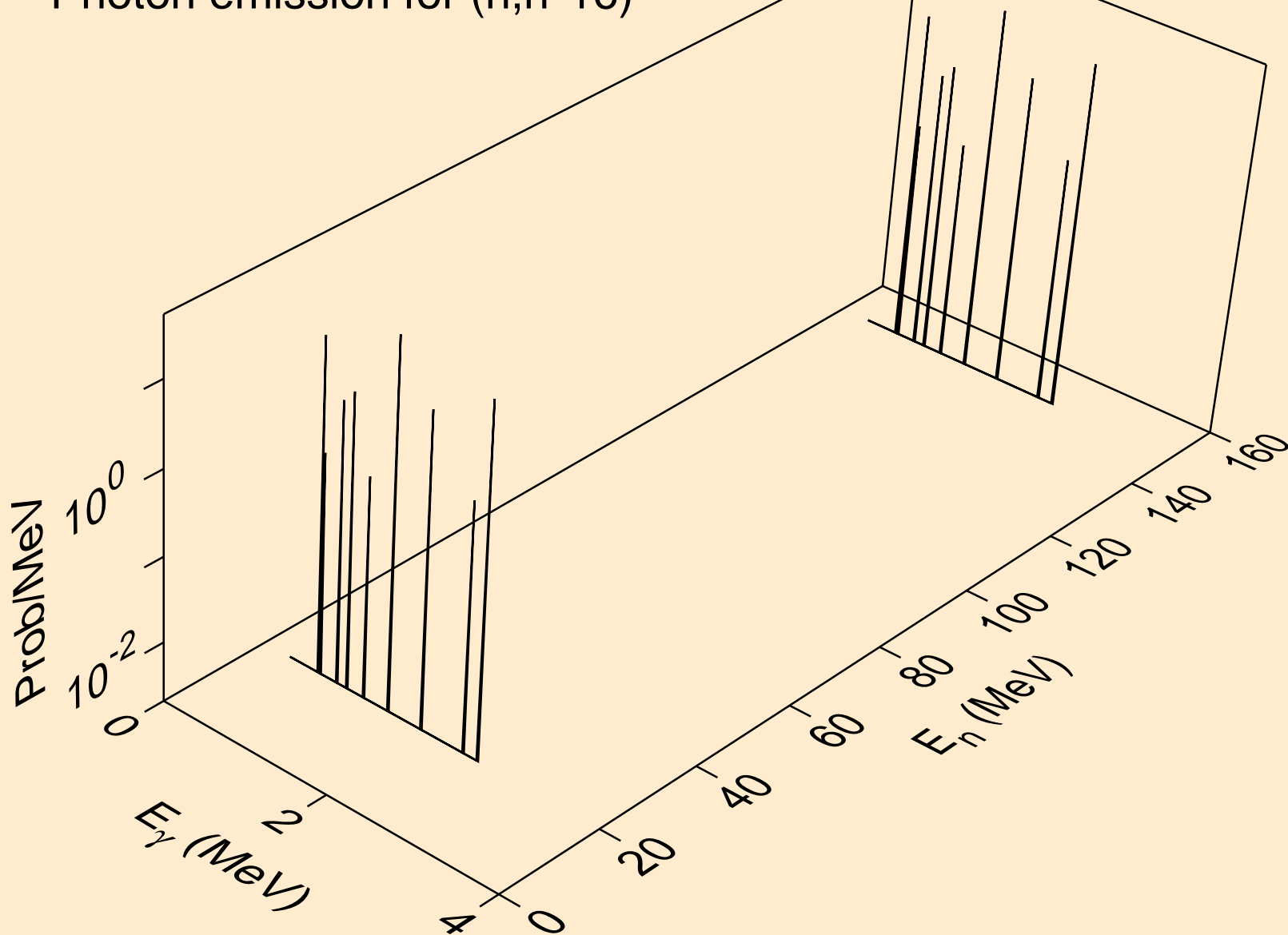

20-CA-42 FOR FENDL-3.1 FROM FENDL-3.1 WITH NJOY2012.50+  
Photon emission for (n,n\*17)

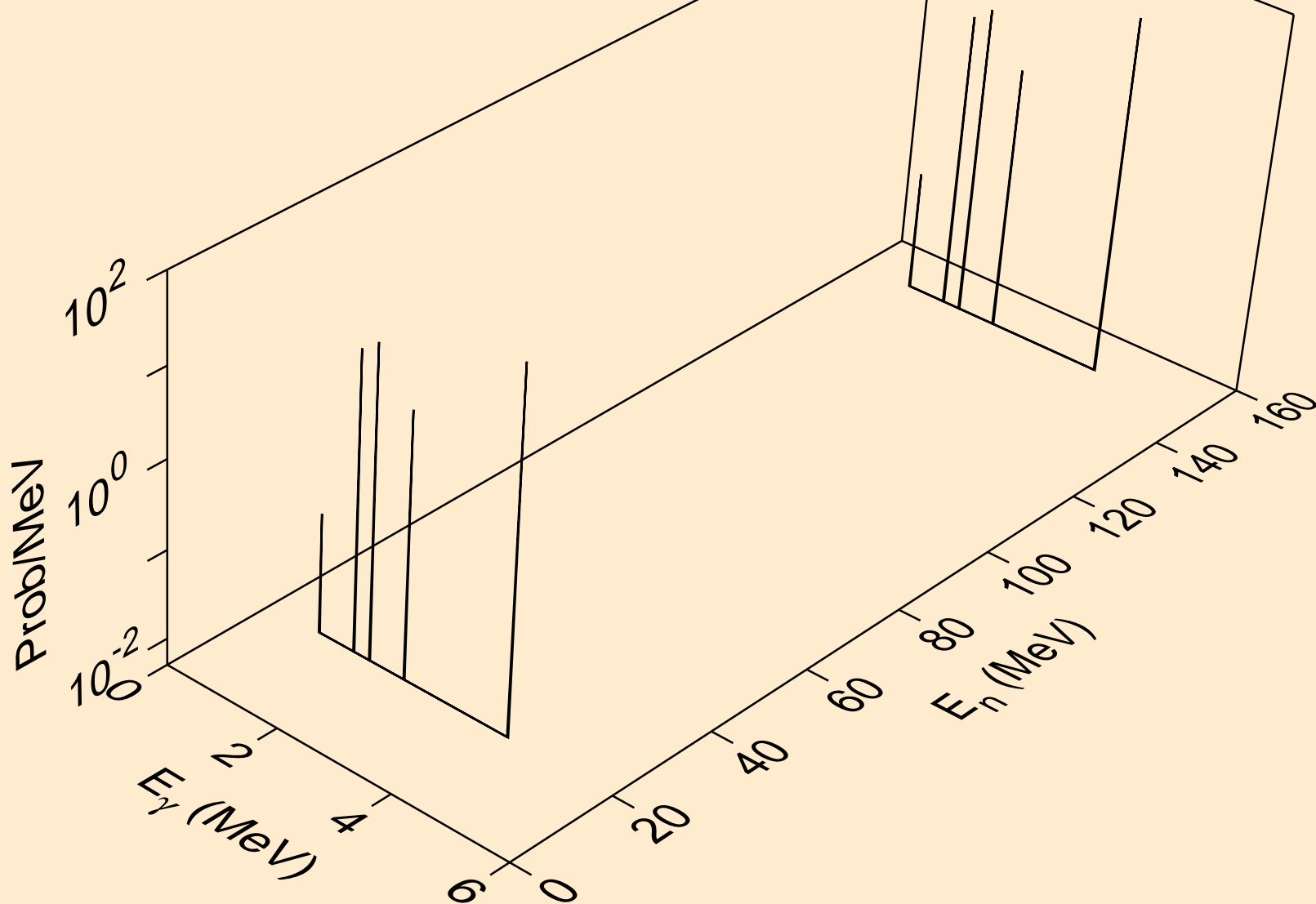

20-CA-42 FOR FENDL-3.1 FROM FENDL-3.1 WITH NJOY2012.50+  
Photon emission for (n,n\*18)

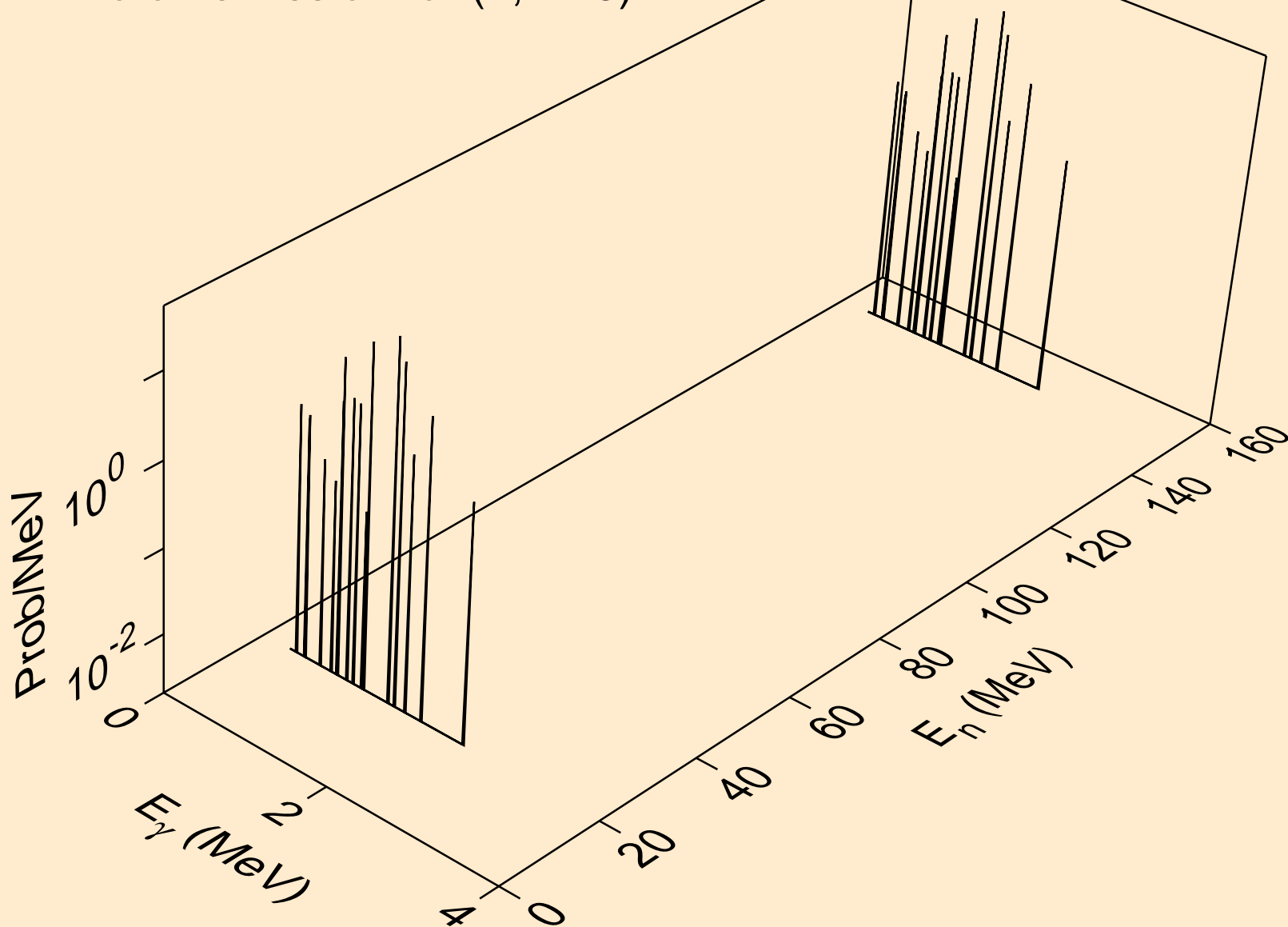

20-CA-42 FOR FENDL-3.1 FROM FENDL-3.1 WITH NJOY2012.50+  
Photon emission for (n,n\*19)

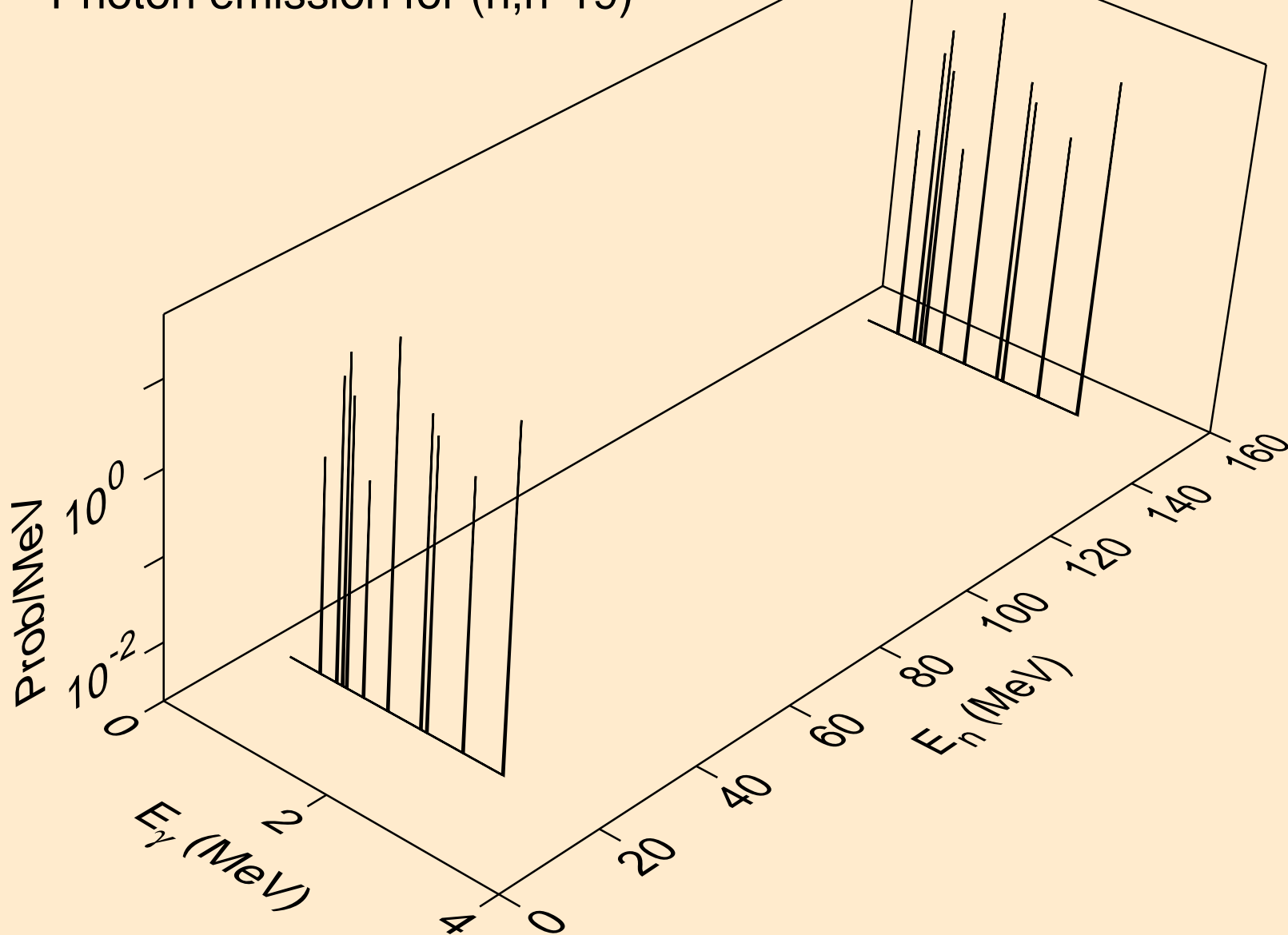

20-CA-42 FOR FENDL-3.1 FROM FENDL-3.1 WITH NJOY2012.50+  
Photon emission for (n,n\*20)

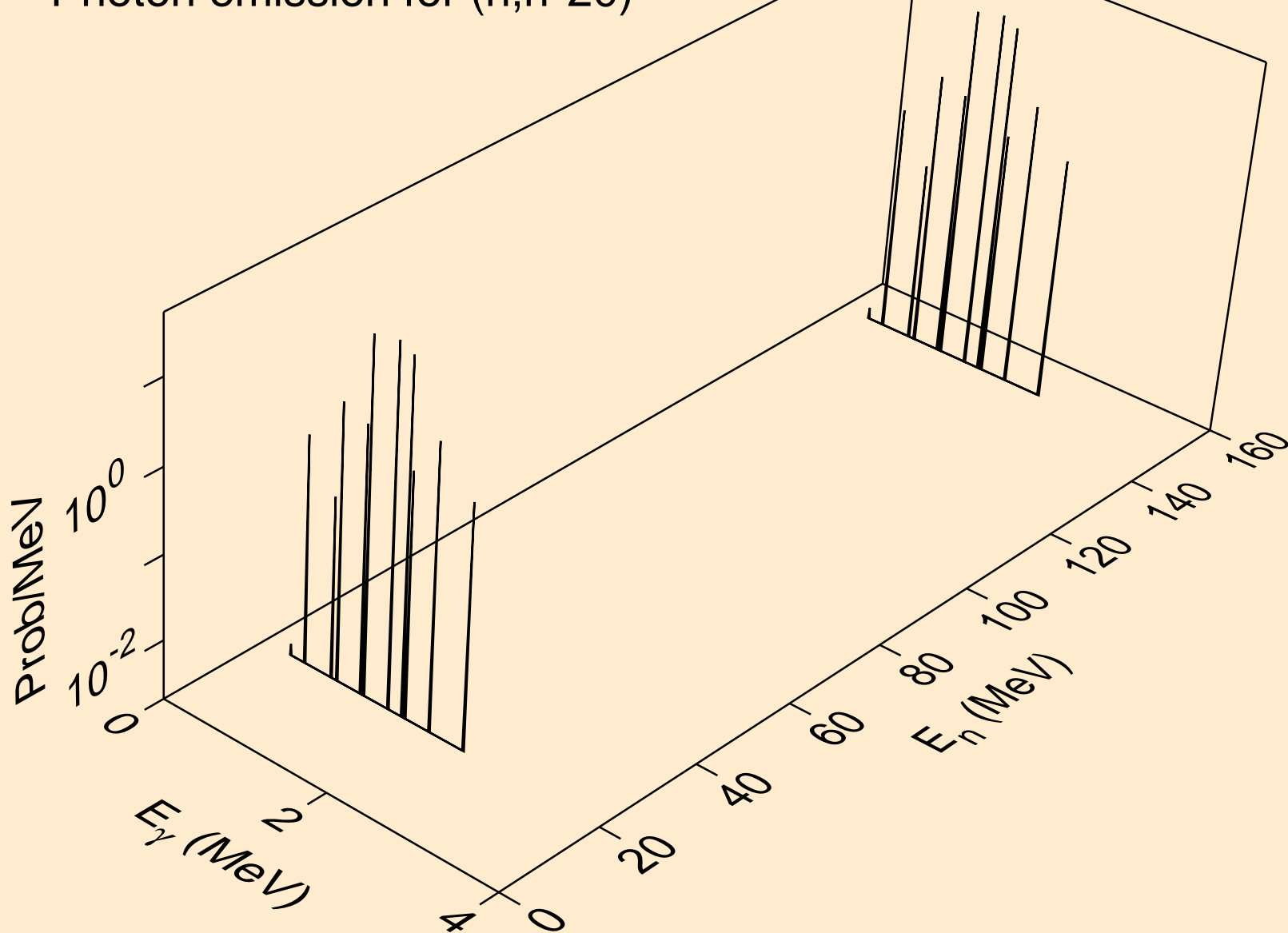



20-CA-42 FOR FENDL-3.1 FROM FENDL-3.1 WITH NJOY2012.50+  
Photon emission for (n,n\*21)

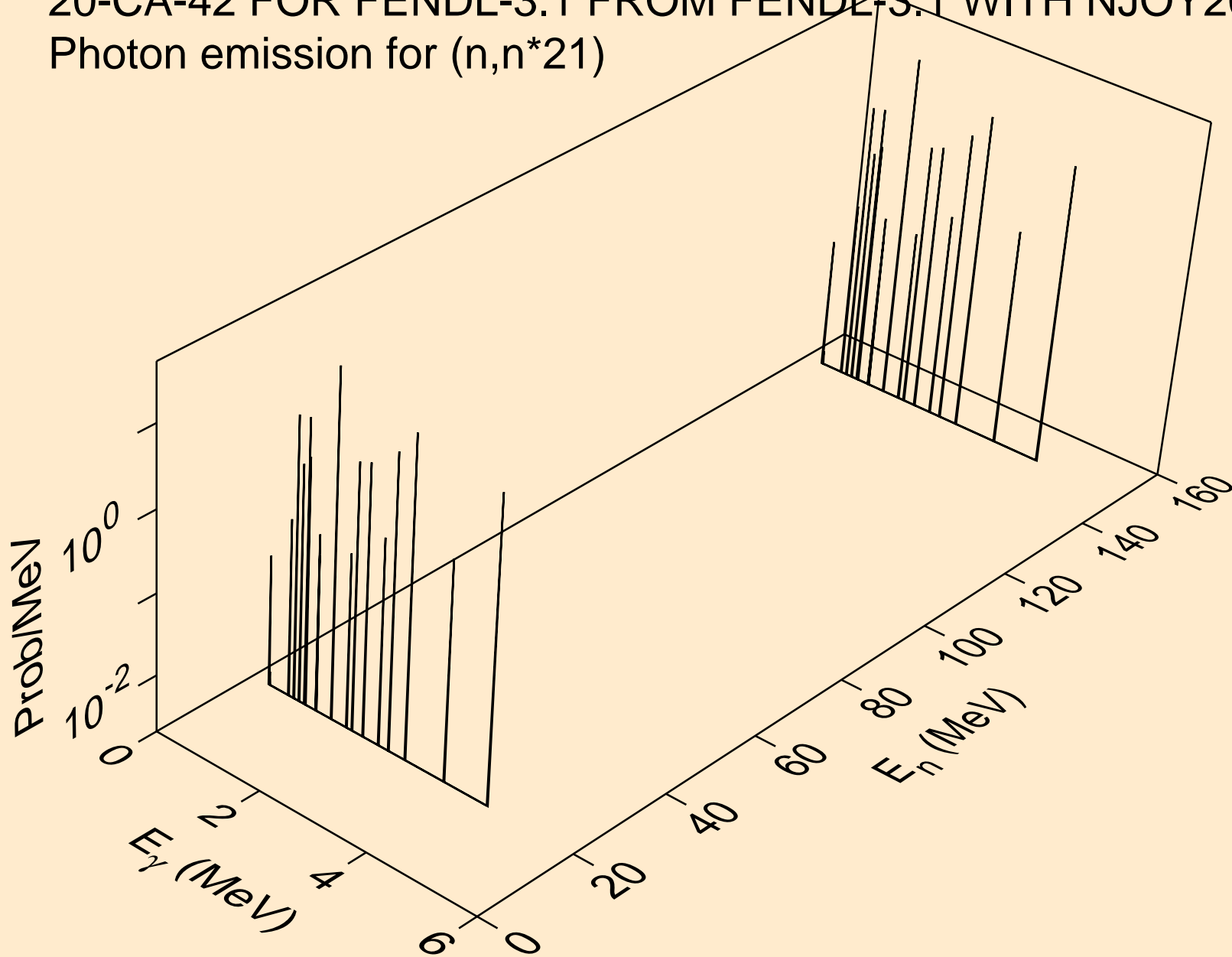

20-CA-42 FOR FENDL-3.1 FROM FENDL-3.1 WITH NJOY2012.50+  
Photon emission for (n,n\*22)

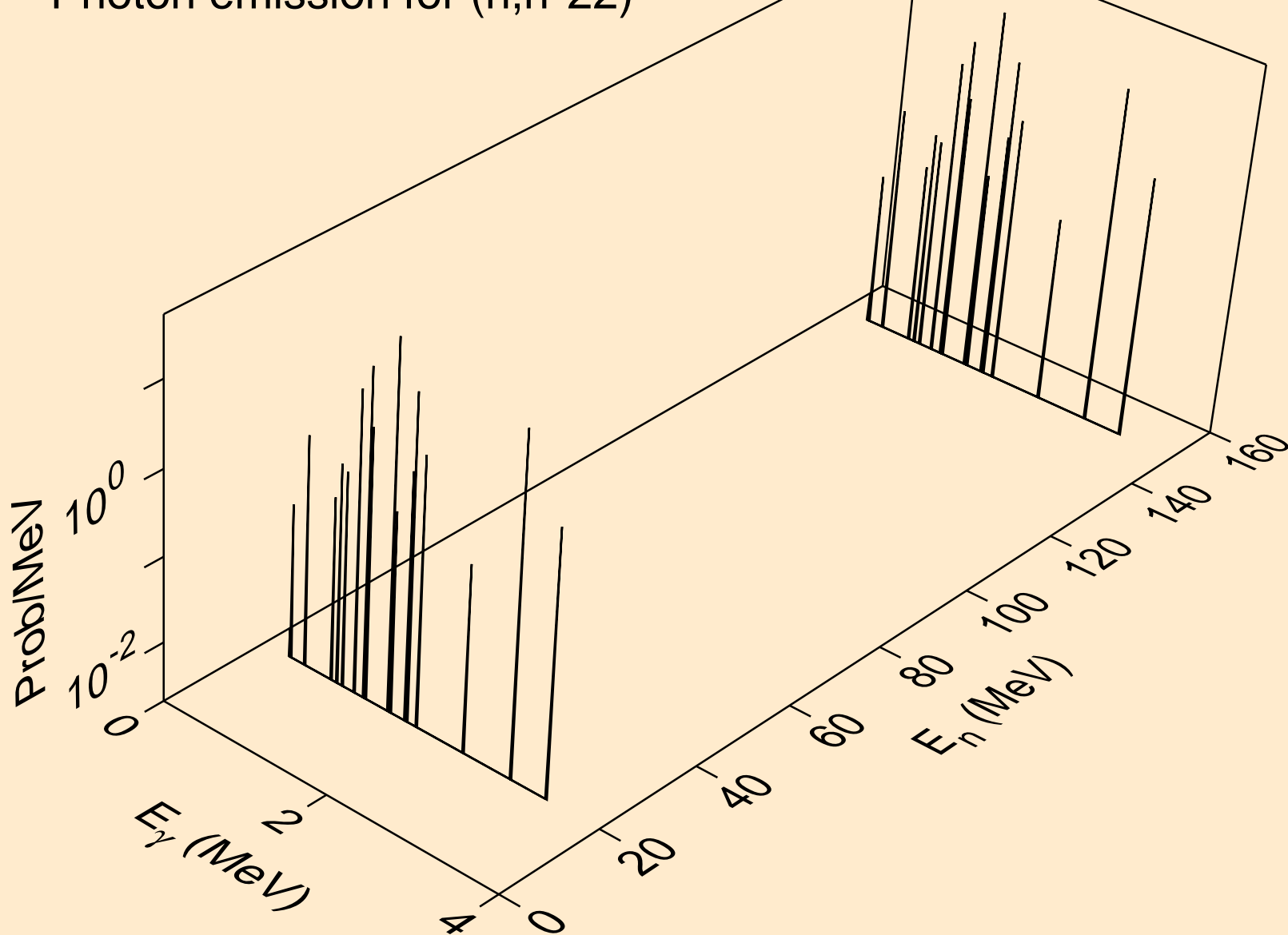

20-CA-42 FOR FENDL-3.1 FROM FENDL-3.1 WITH NJOY2012.50+  
Photon emission for (n,n\*23)

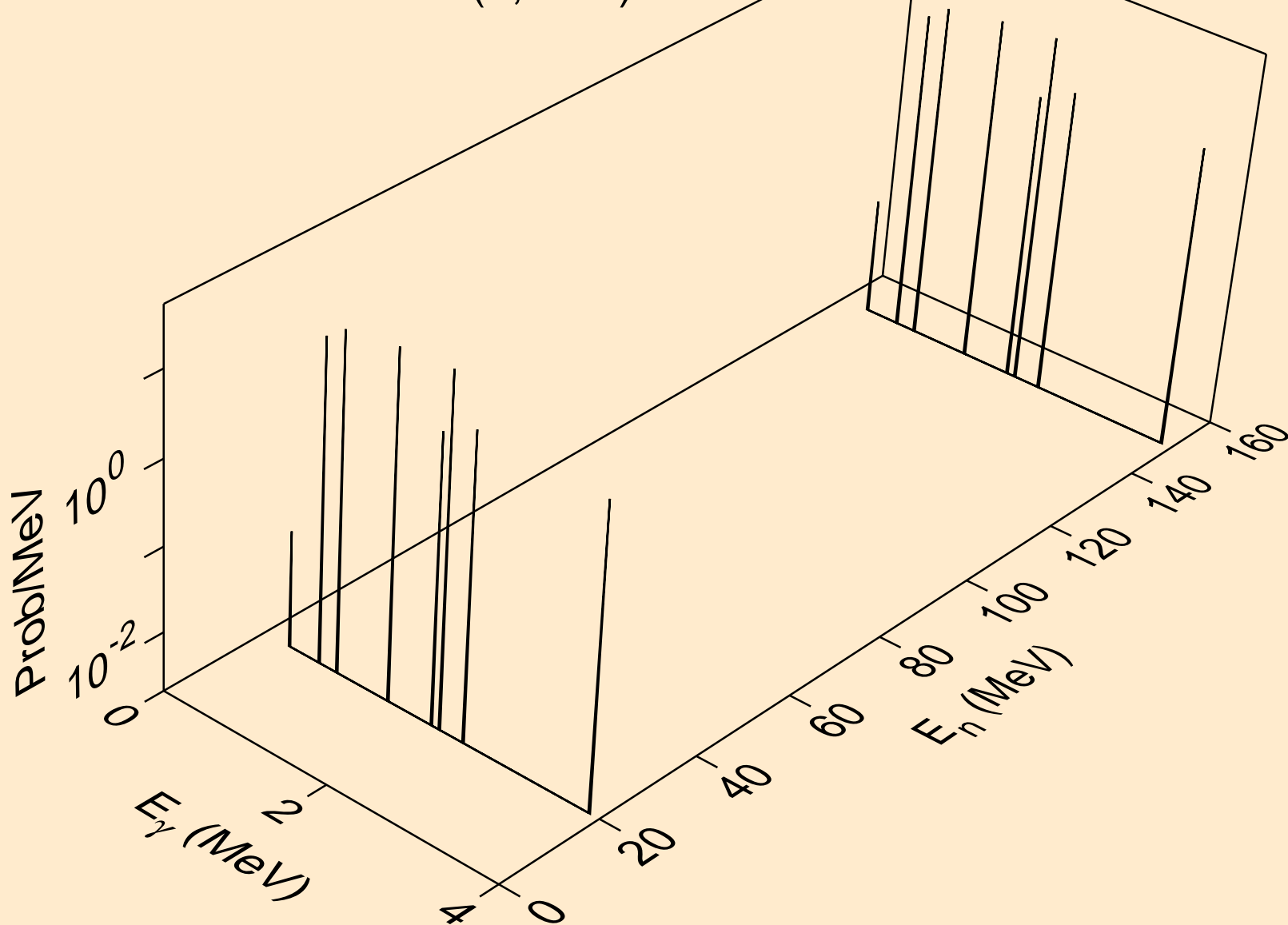

20-CA-42 FOR FENDL-3.1 FROM FENDL-3.1 WITH NJOY2012.50+  
Photon emission for (n,n\*24)

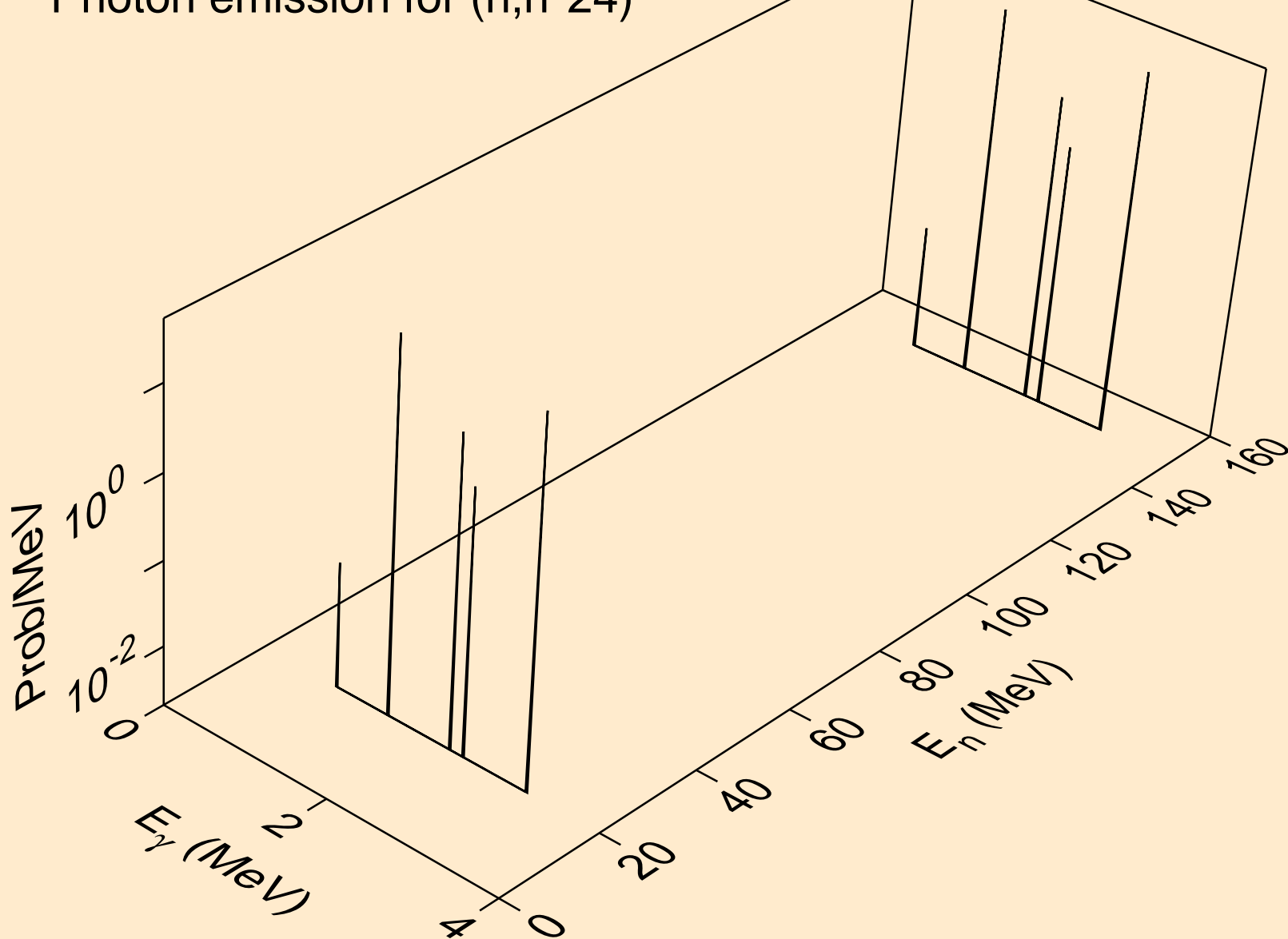

20-CA-42 FOR FENDL-3.1 FROM FENDL-3.1 WITH NJOY2012.50+  
Photon emission for (n,n\*25)

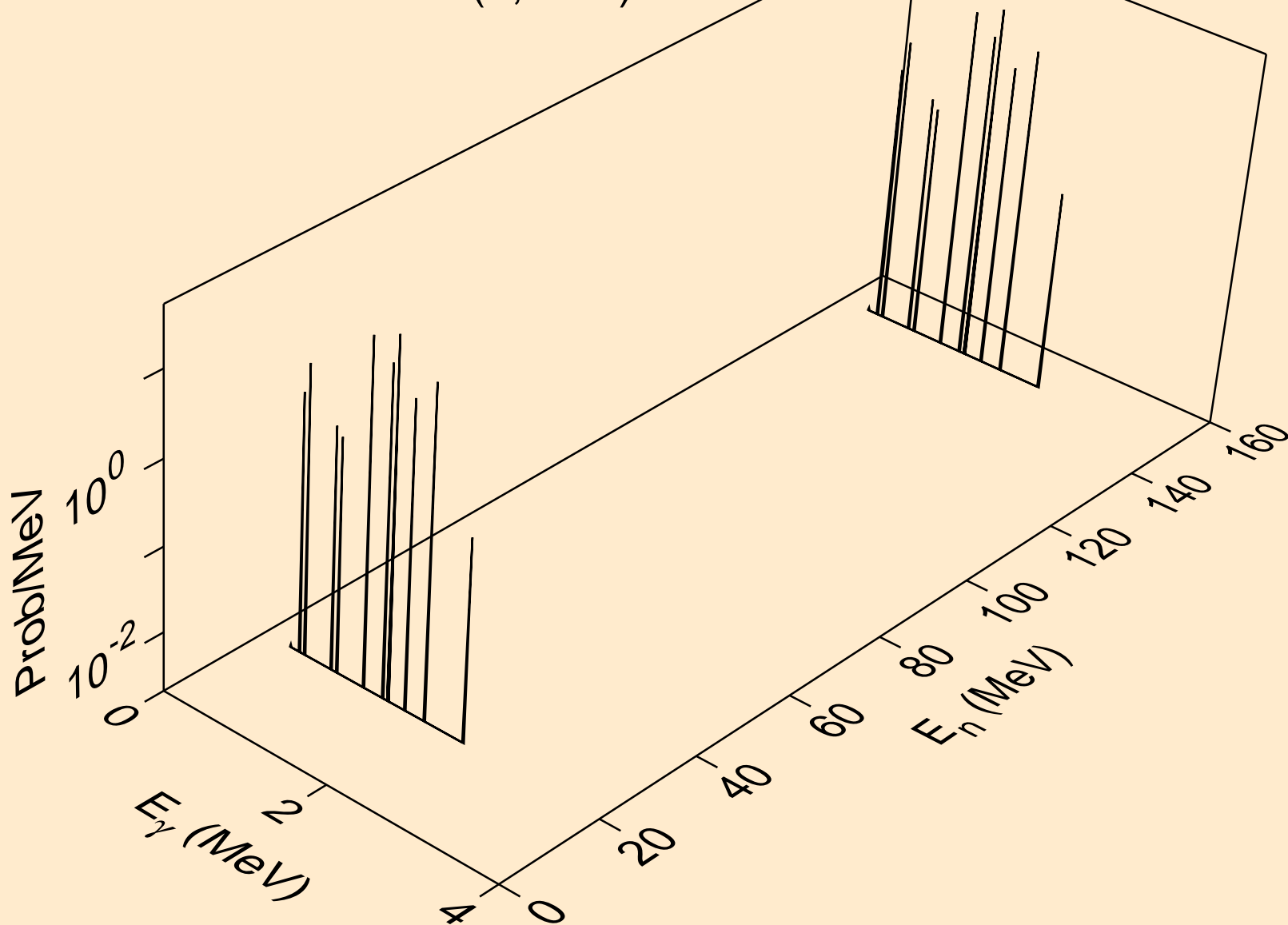

20-CA-42 FOR FENDL-3.1 FROM FENDL-3.1 WITH NJOY2012.50+  
Photon emission for (n,n\*26)

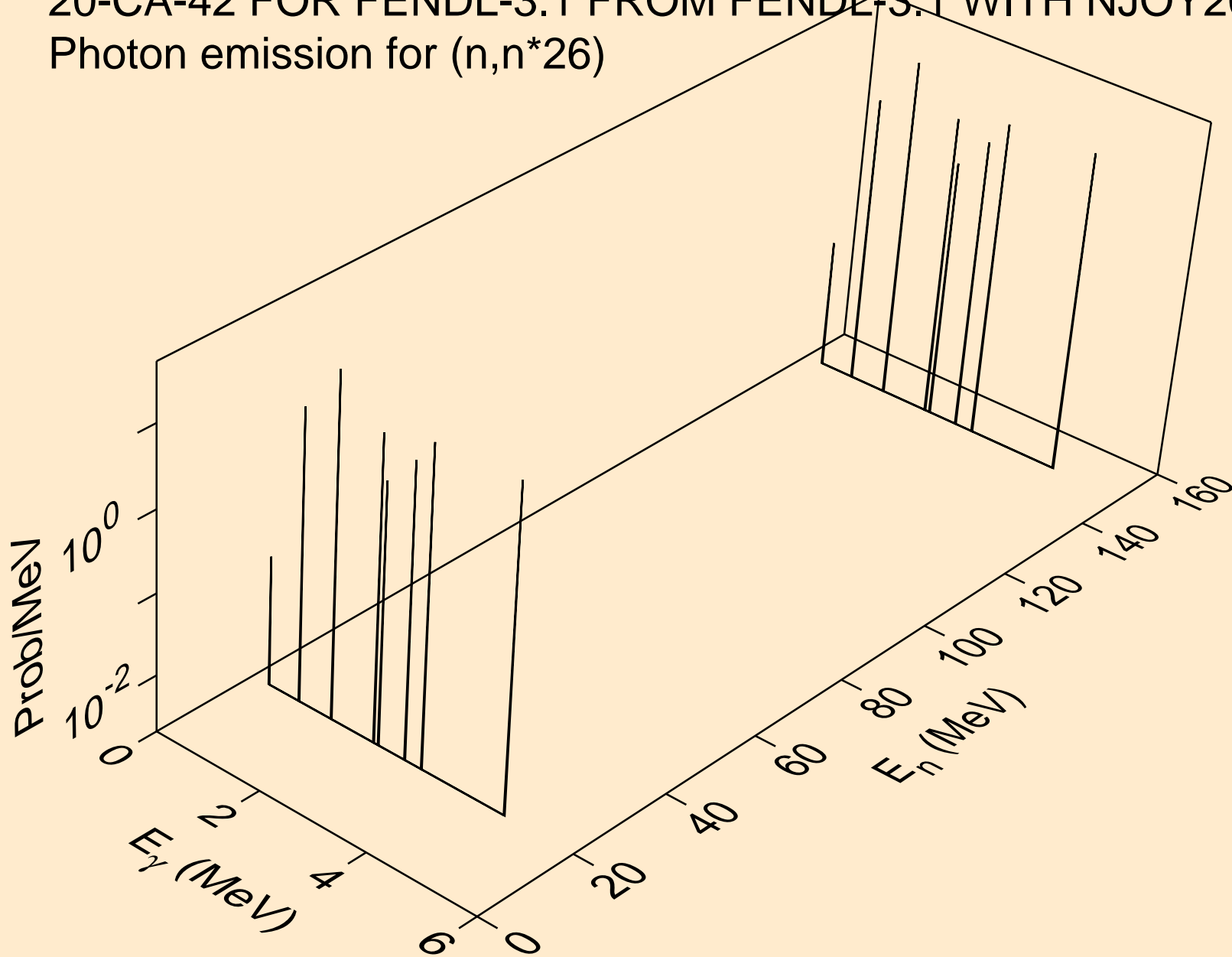

20-CA-42 FOR FENDL-3.1 FROM FENDL-3.1 WITH NJOY2012.50+  
Photon emission for (n,n\*27)

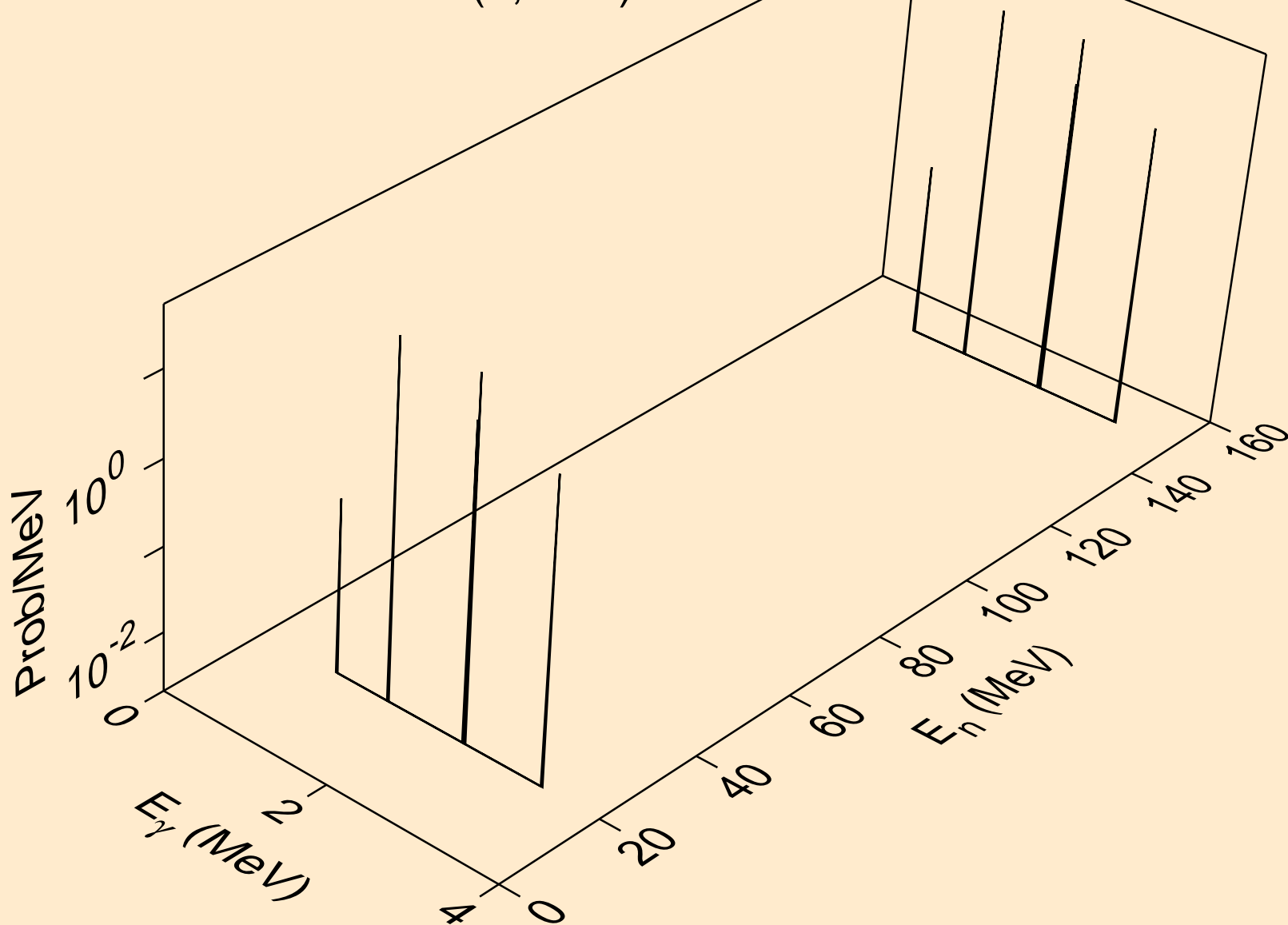

20-CA-42 FOR FENDL-3.1 FROM FENDL-3.1 WITH NJOY2012.50+  
Photon emission for (n,n\*28)

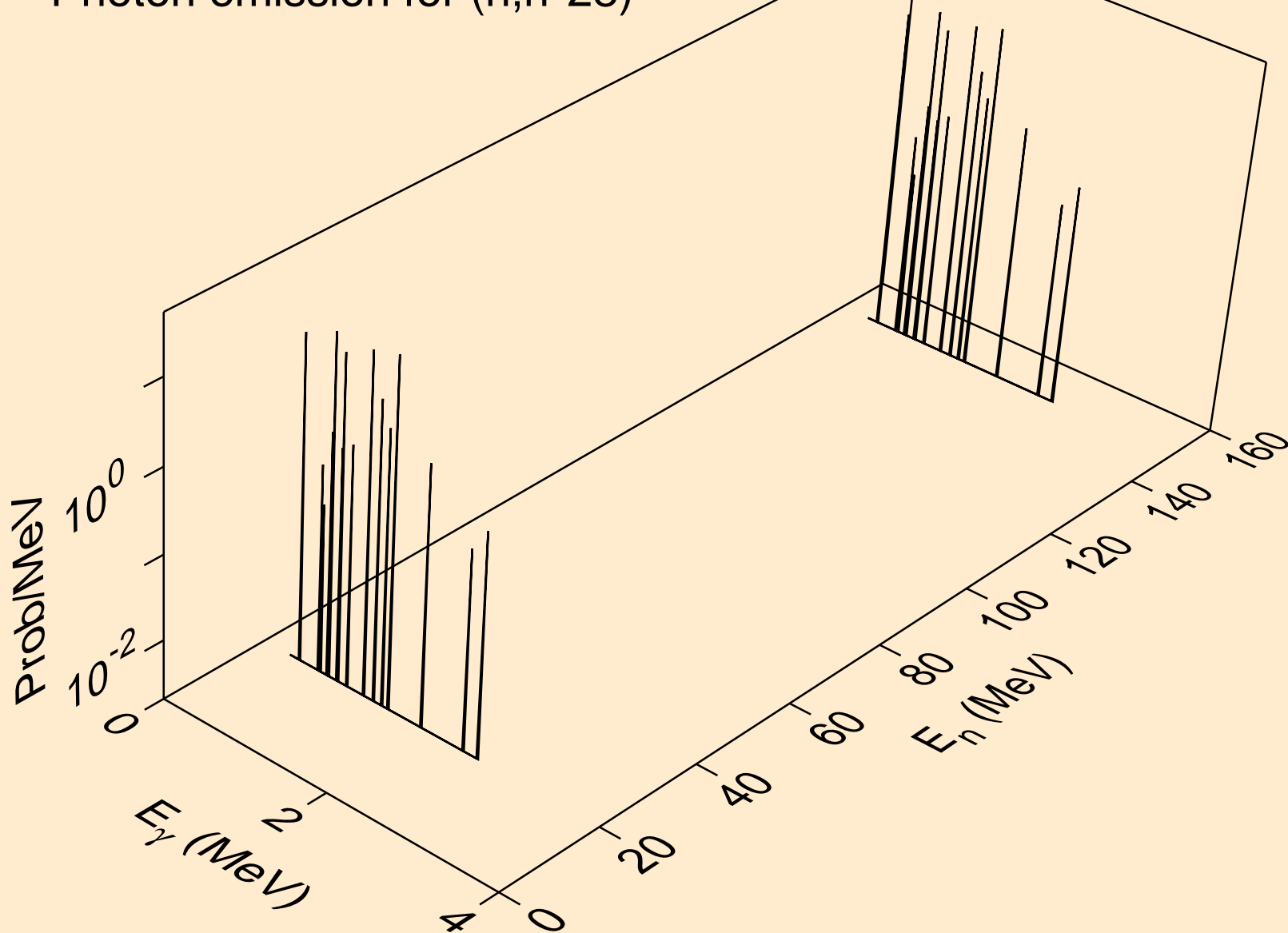



20-CA-42 FOR FENDL-3.1 FROM FENDL-3.1 WITH NJOY2012.50+  
Photon emission for (n,n\*29)

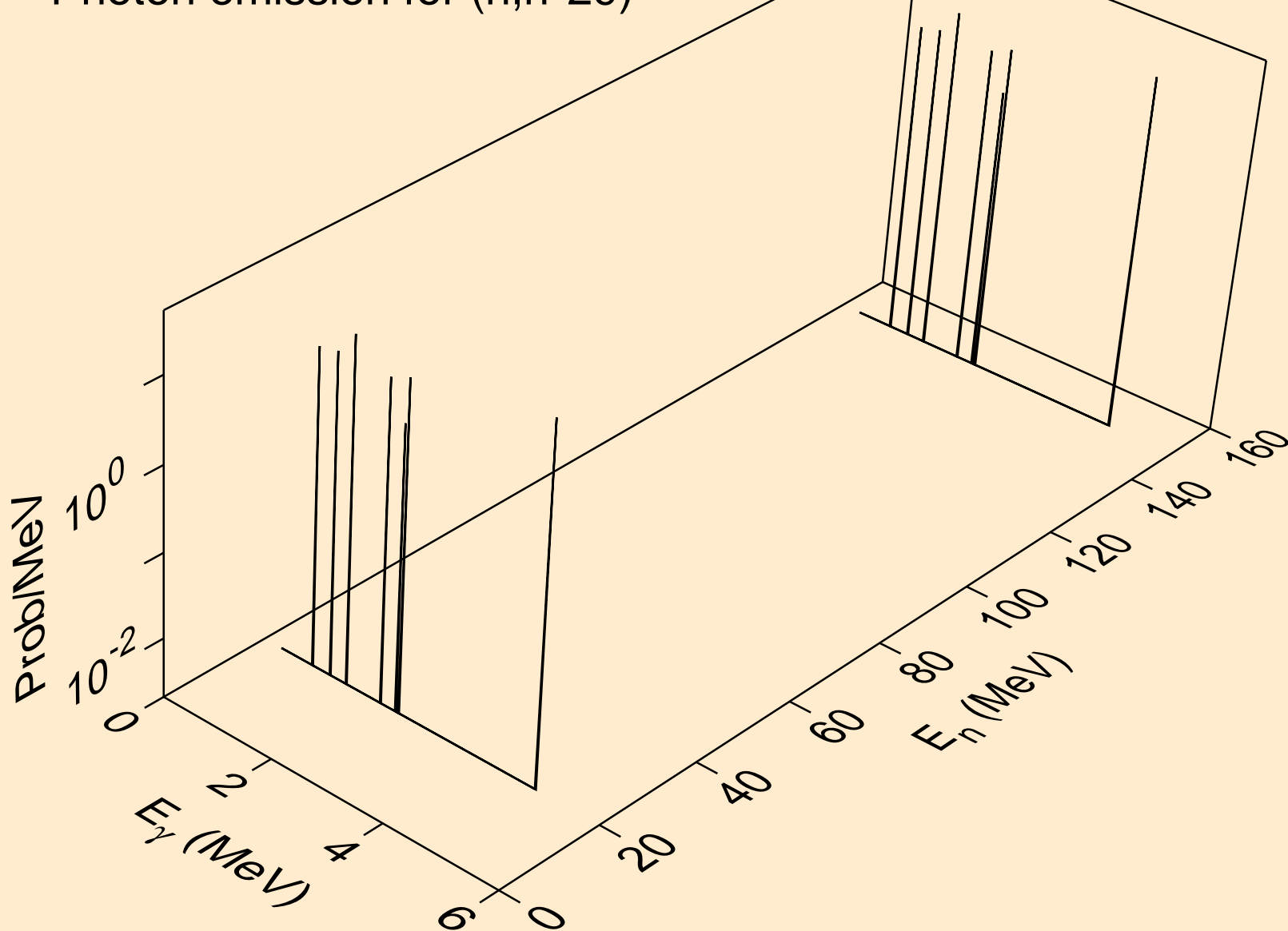

20-CA-42 FOR FENDL-3.1 FROM FENDL-3.1 WITH NJOY2012.50+  
Photon emission for (n,n\*30)

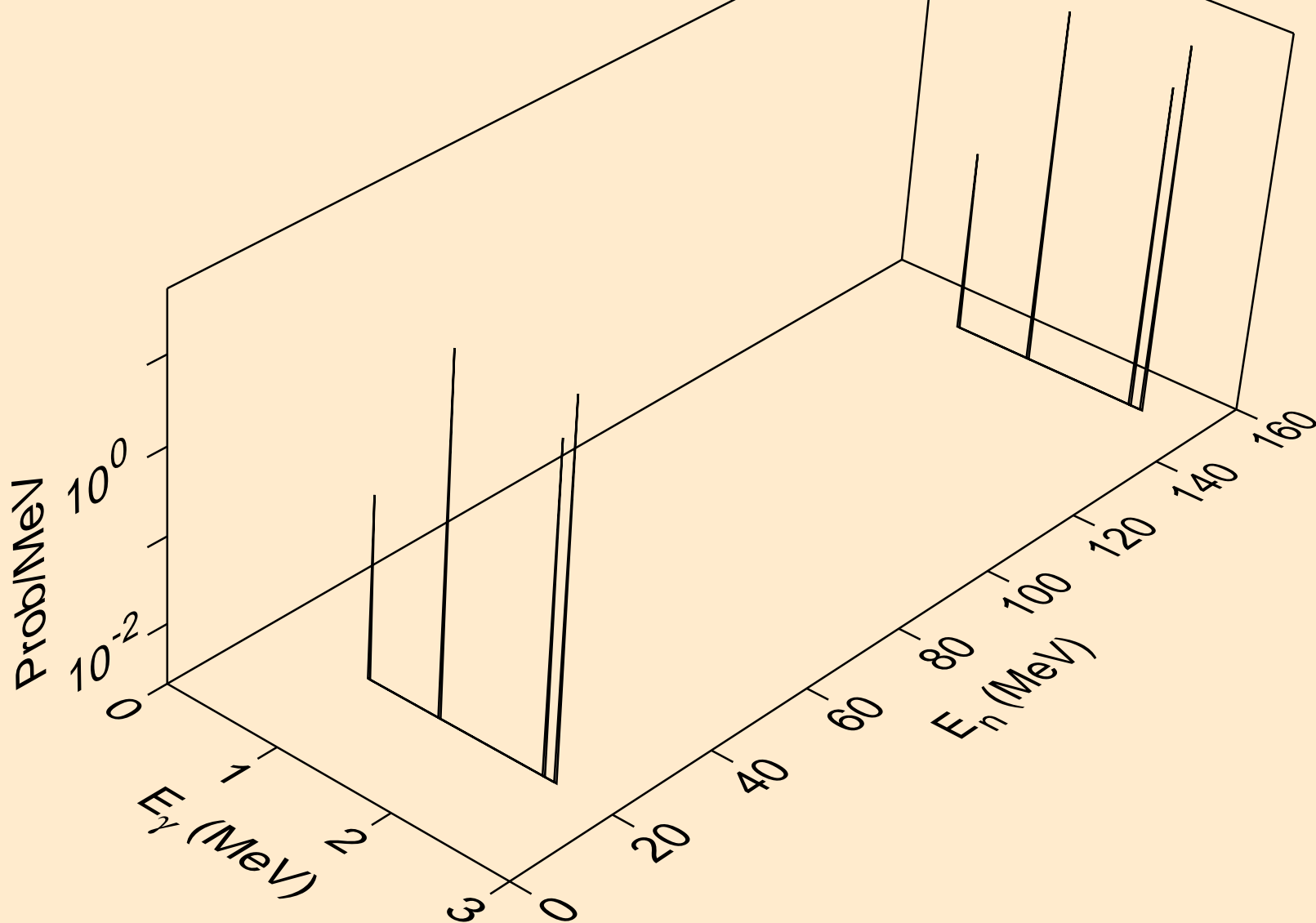

20-CA-42 FOR FENDL-3.1 FROM FENDL-3.1 WITH NJOY2012.50+  
Photon emission for (n,n\*31)

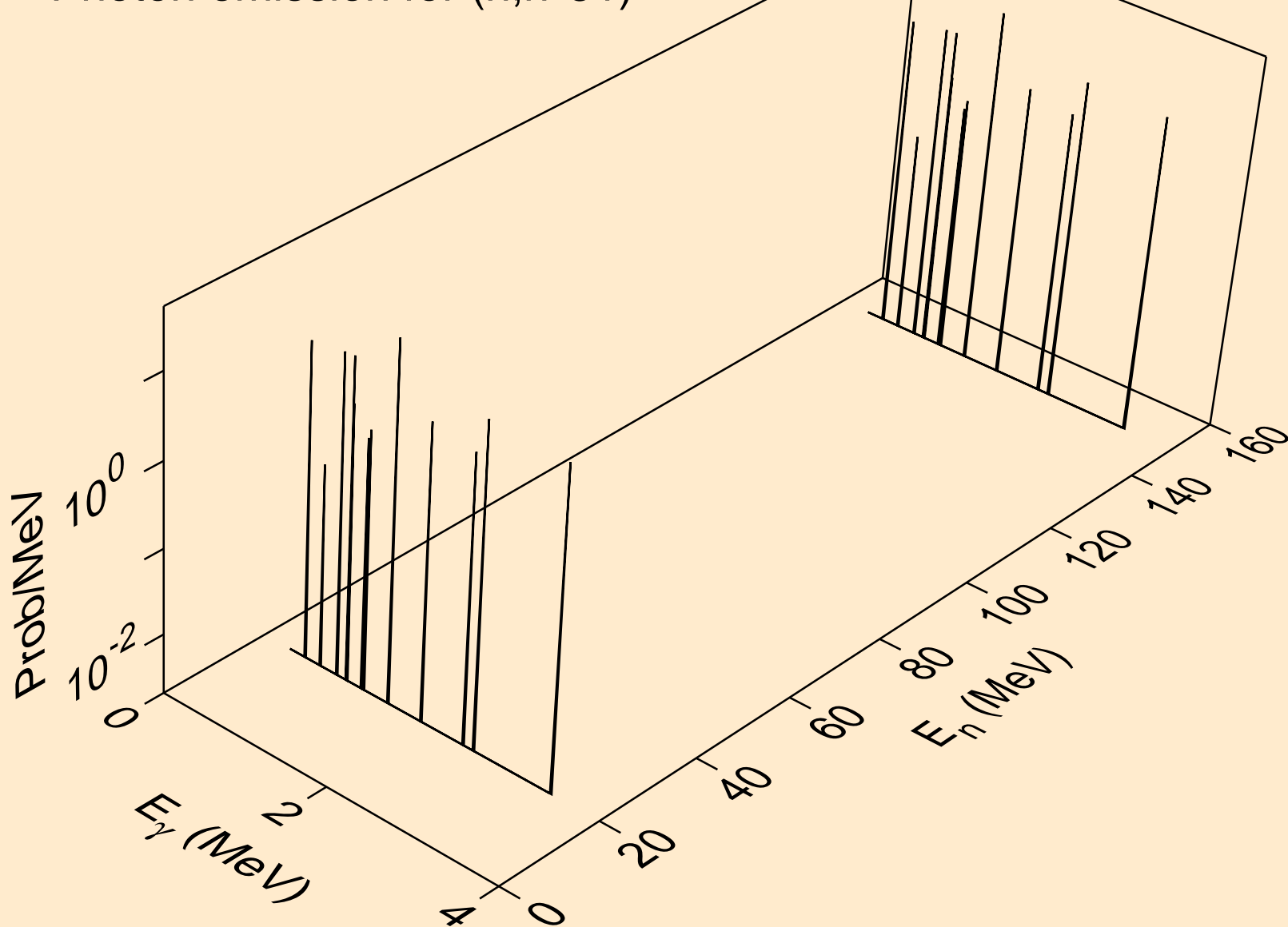

20-CA-42 FOR FENDL-3.1 FROM FENDL-3.1 WITH NJOY2012.50+  
Photon emission for (n,n\*32)

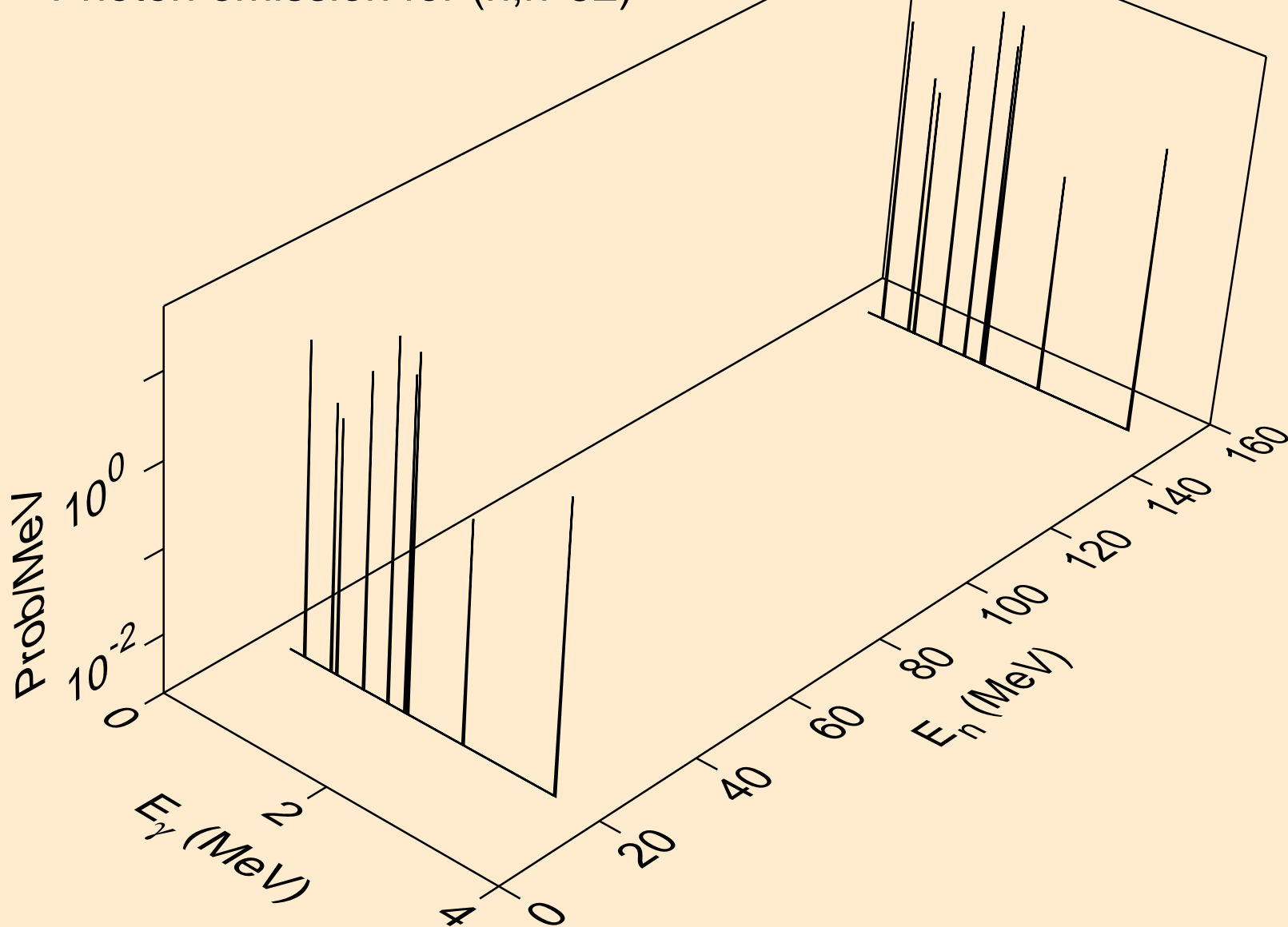

20-CA-42 FOR FENDL-3.1 FROM FENDL-3.1 WITH NJOY2012.50+  
Photon emission for (n,n\*33)

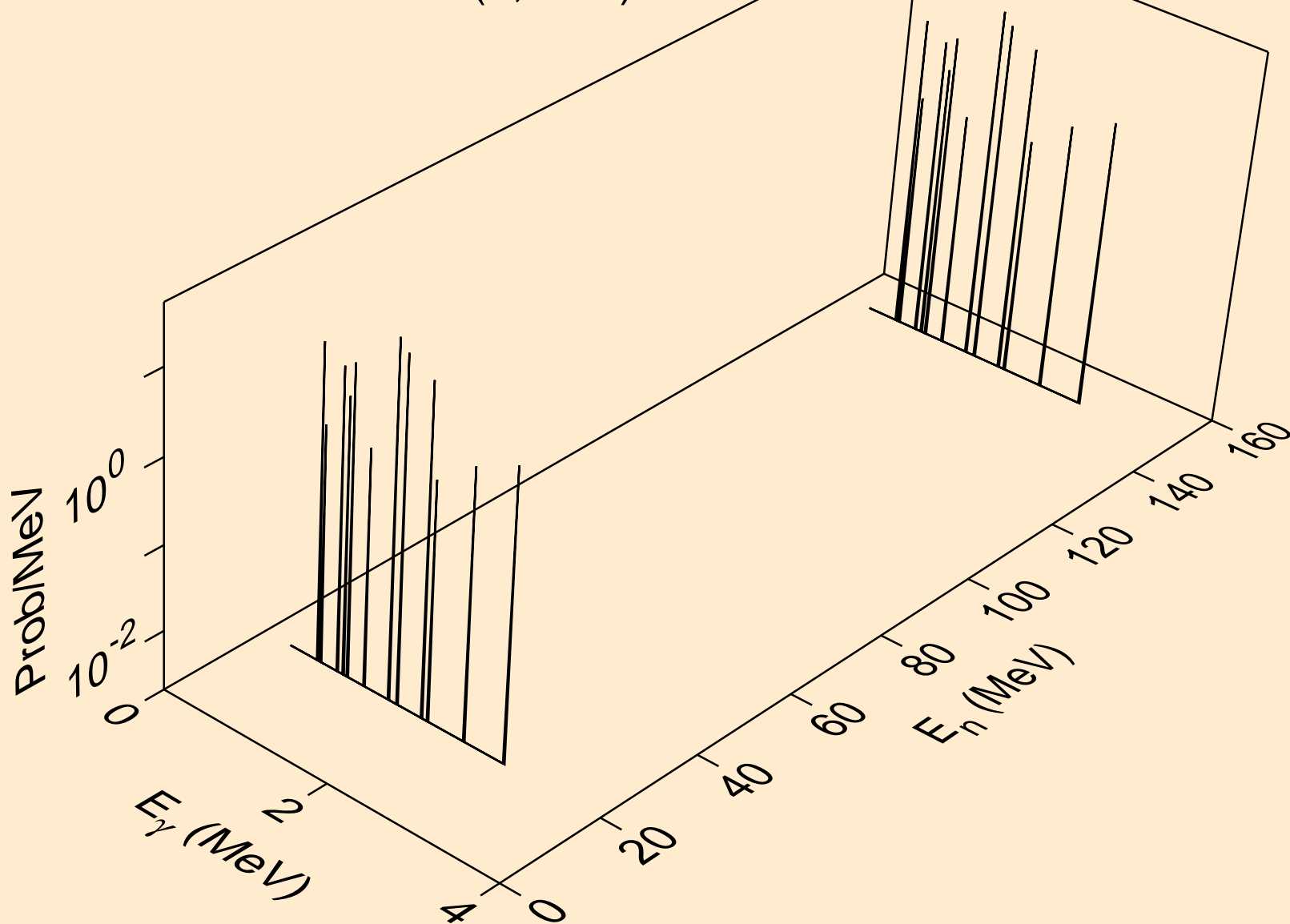

20-CA-42 FOR FENDL-3.1 FROM FENDL-3.1 WITH NJOY2012.50+  
Photon emission for (n,n\*34)

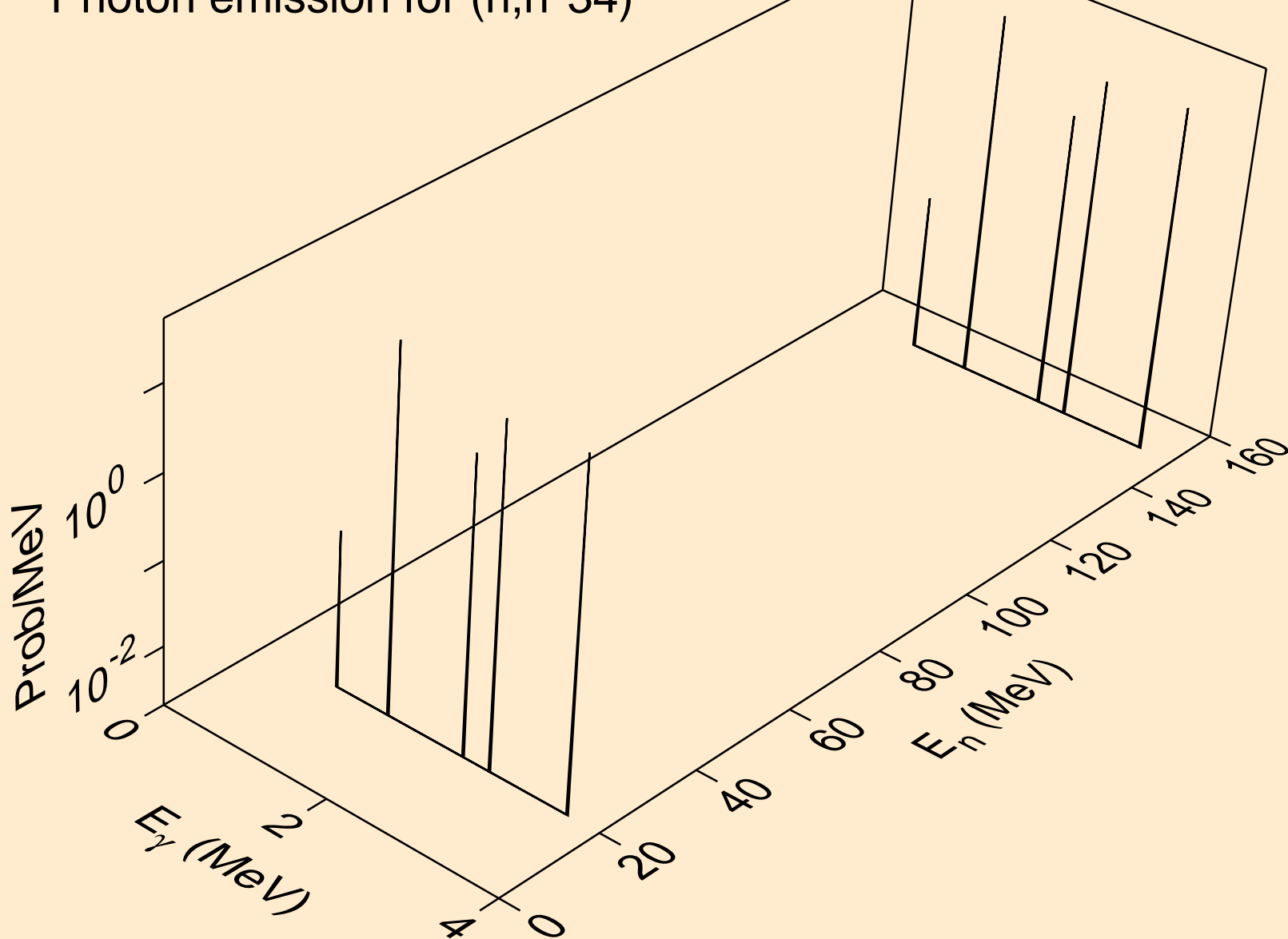

20-CA-42 FOR FENDL-3.1 FROM FENDL-3.1 WITH NJOY2012.50+  
Photon emission for (n,n\*35)

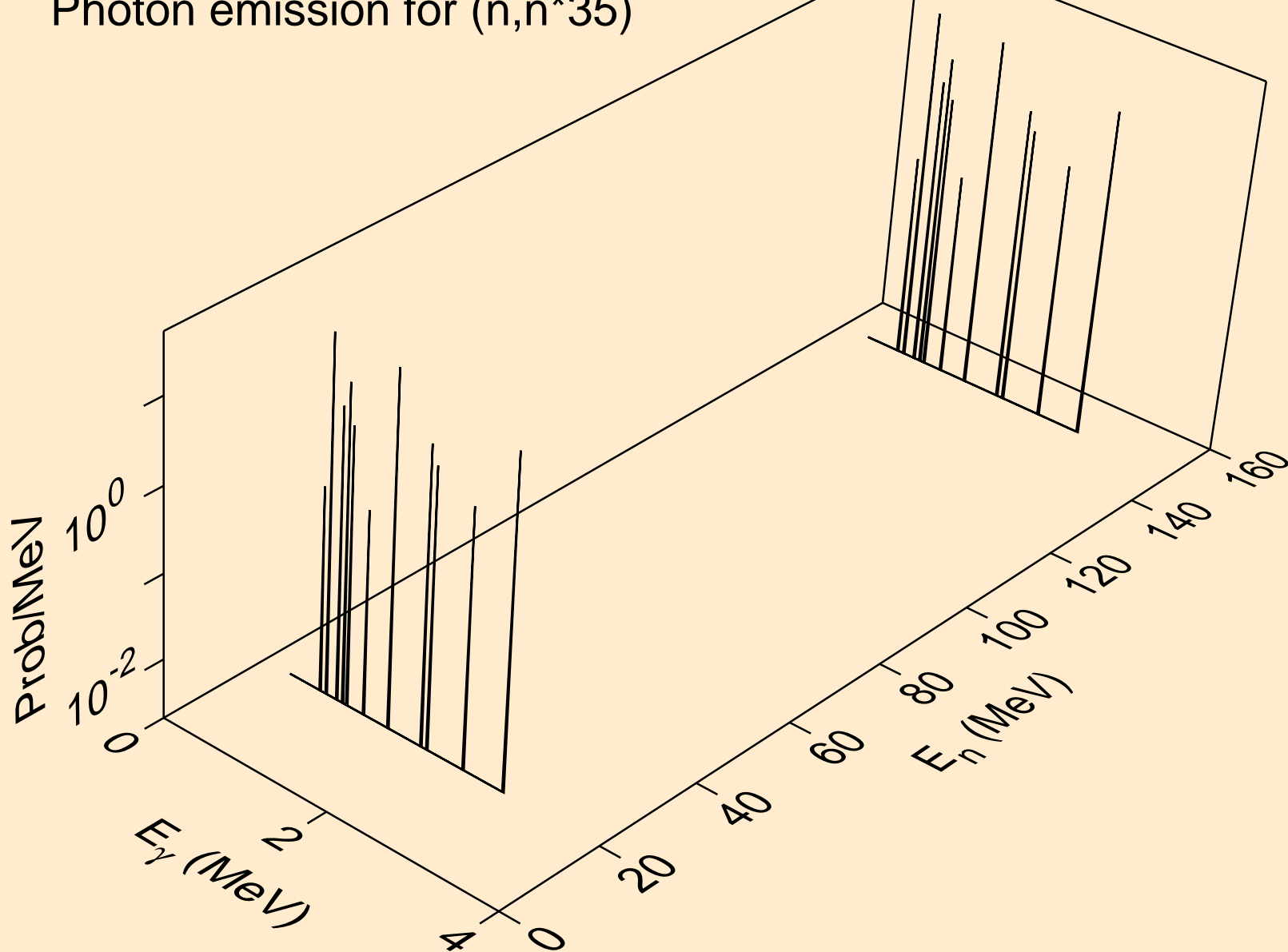

20-CA-42 FOR FENDL-3.1 FROM FENDL-3.1 WITH NJOY2012.50+  
Photon emission for (n,n\*36)

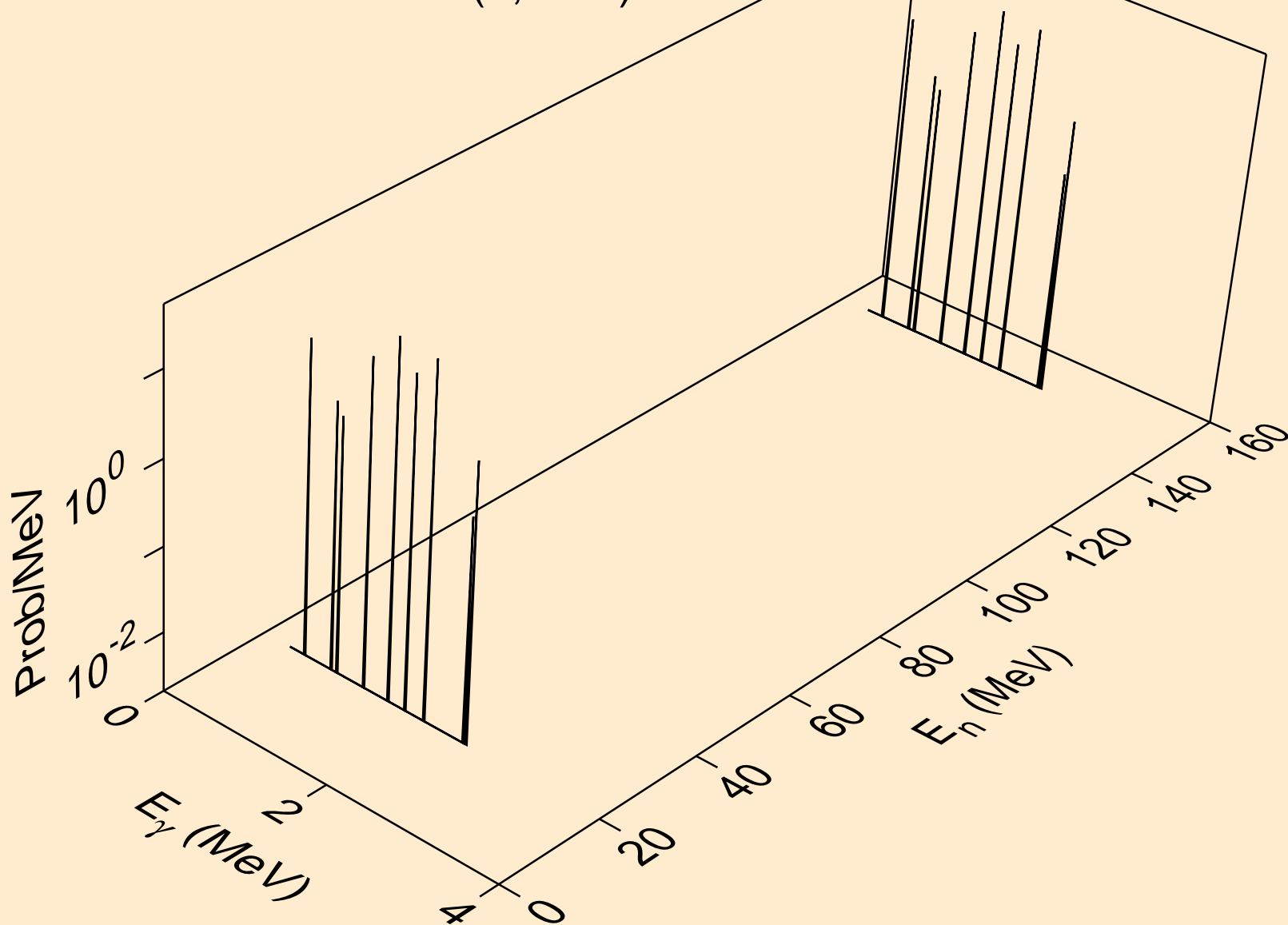



20-CA-42 FOR FENDL-3.1 FROM FENDL-3.1 WITH NJOY2012.50+  
Photon emission for (n,n\*37)

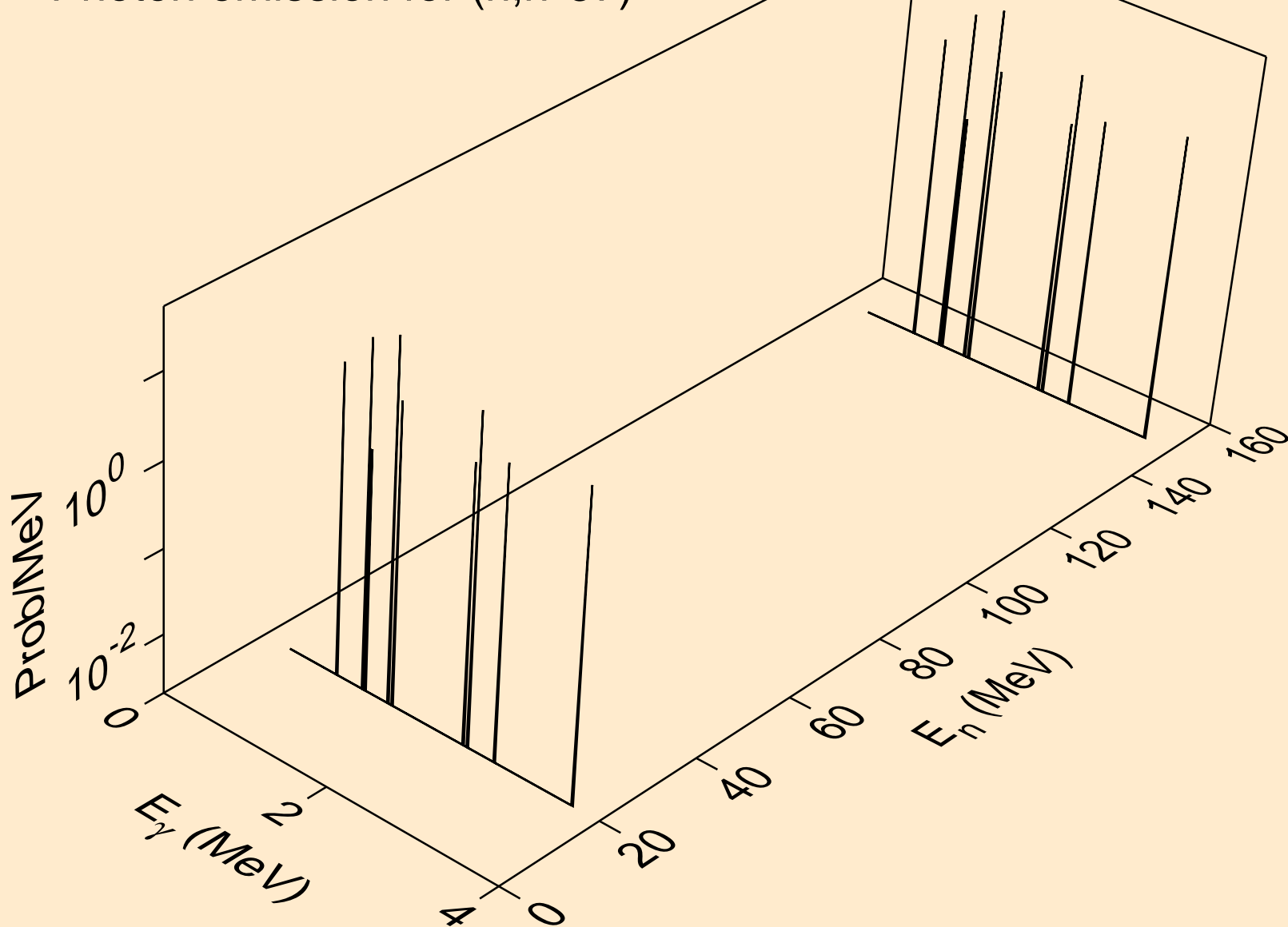

20-CA-42 FOR FENDL-3.1 FROM FENDL-3.1 WITH NJOY2012.50+  
Photon emission for (n,n\*38)

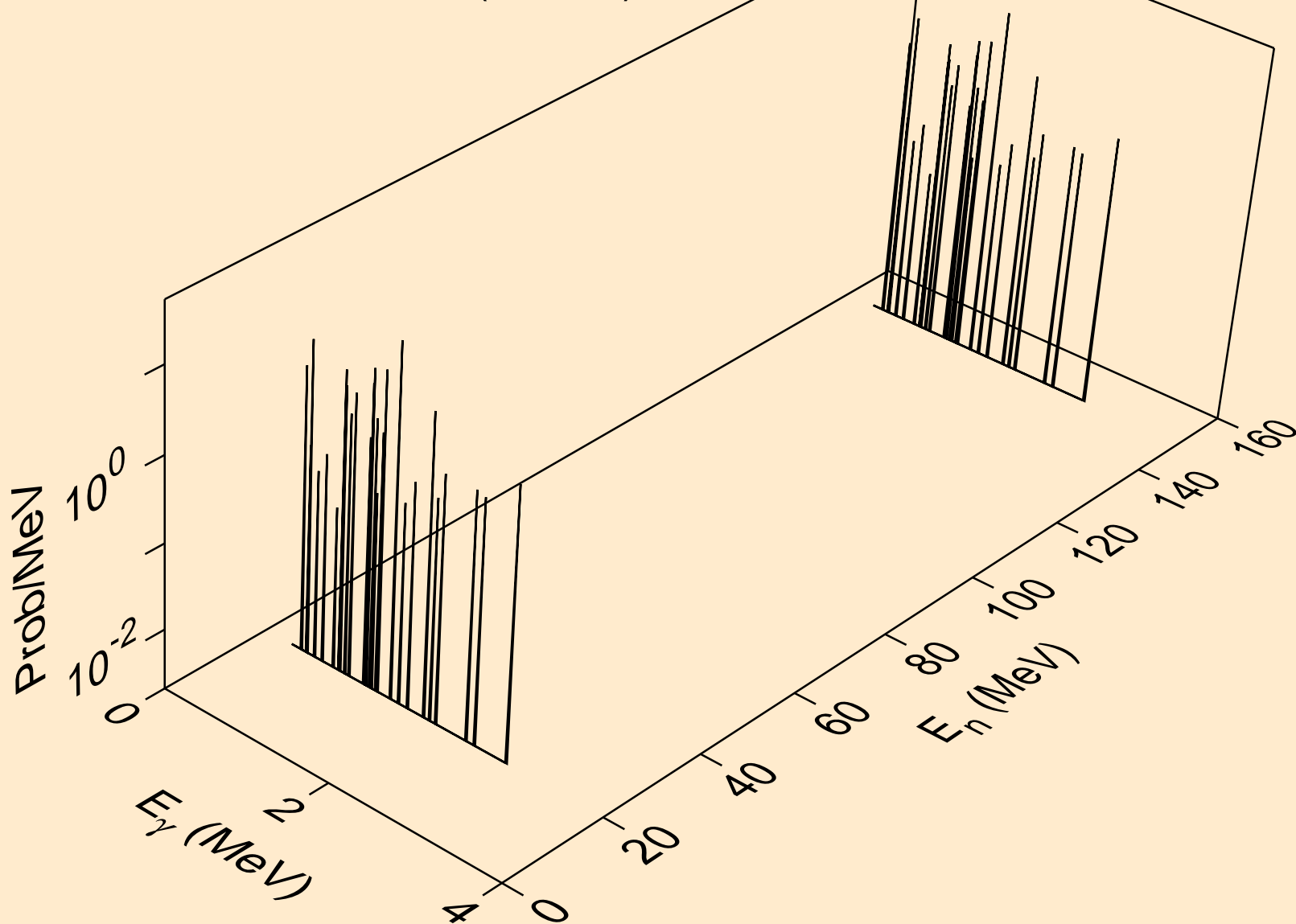

20-CA-42 FOR FENDL-3.1 FROM FENDL-3.1 WITH NJOY2012.50+  
Photon emission for (n,n\*39)

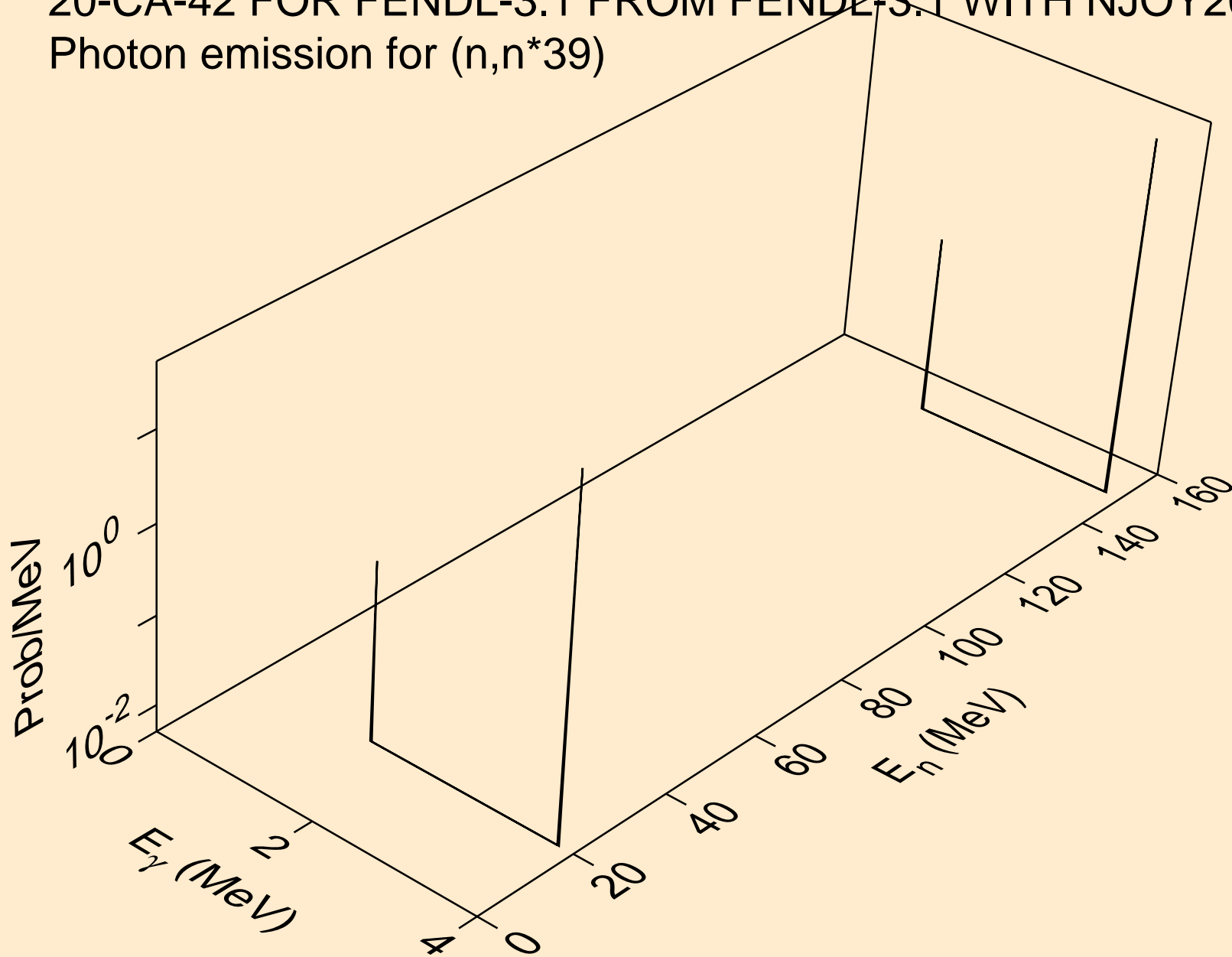

20-CA-42 FOR FENDL-3.1 FROM FENDL-3.1 WITH NJOY2012.50+  
Photon emission for (n,n\*c)

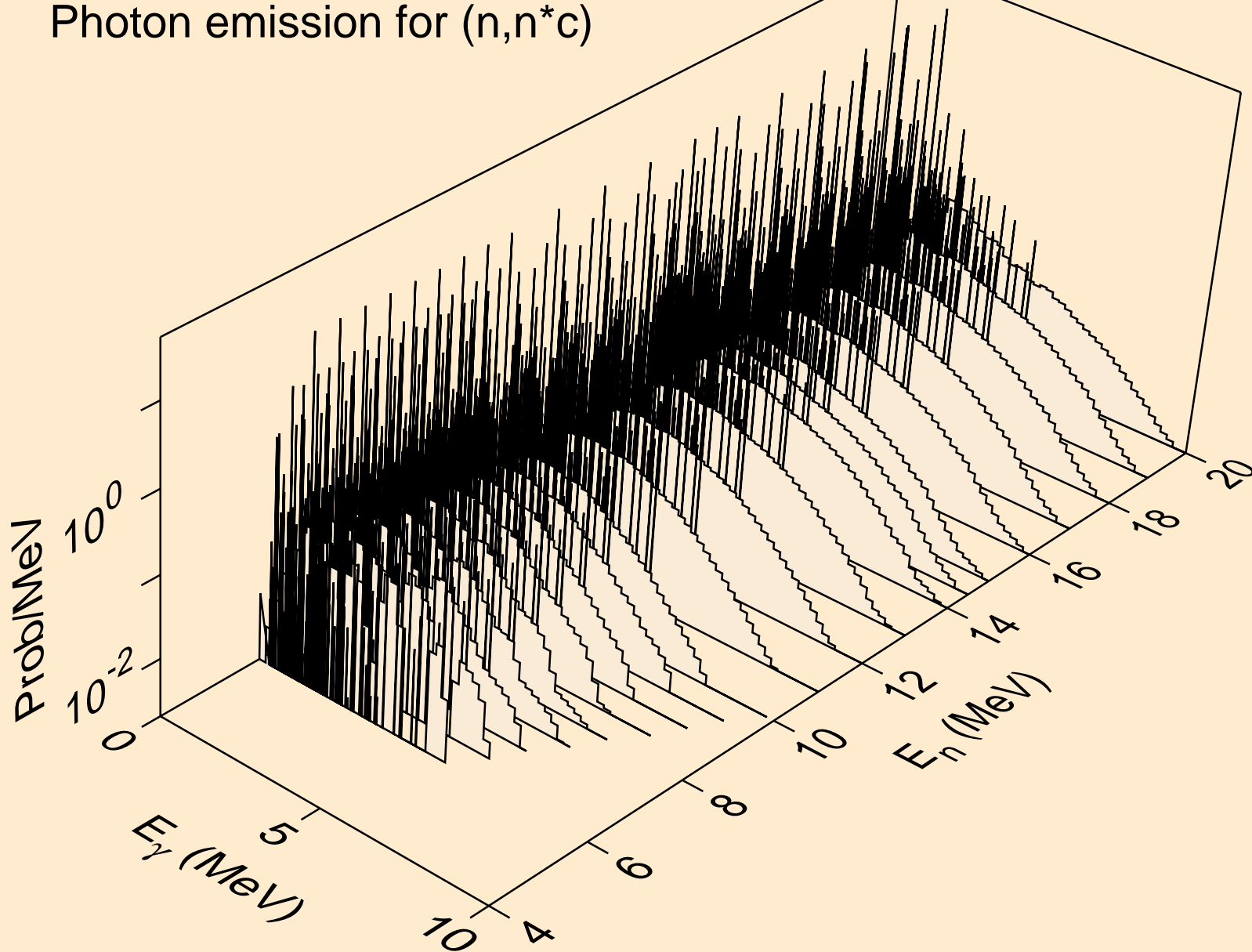

20-CA-42 FOR FENDL-3.1 FROM FENDL-3.1 WITH NJOY2012.50+  
Photon emission for (n,gma)

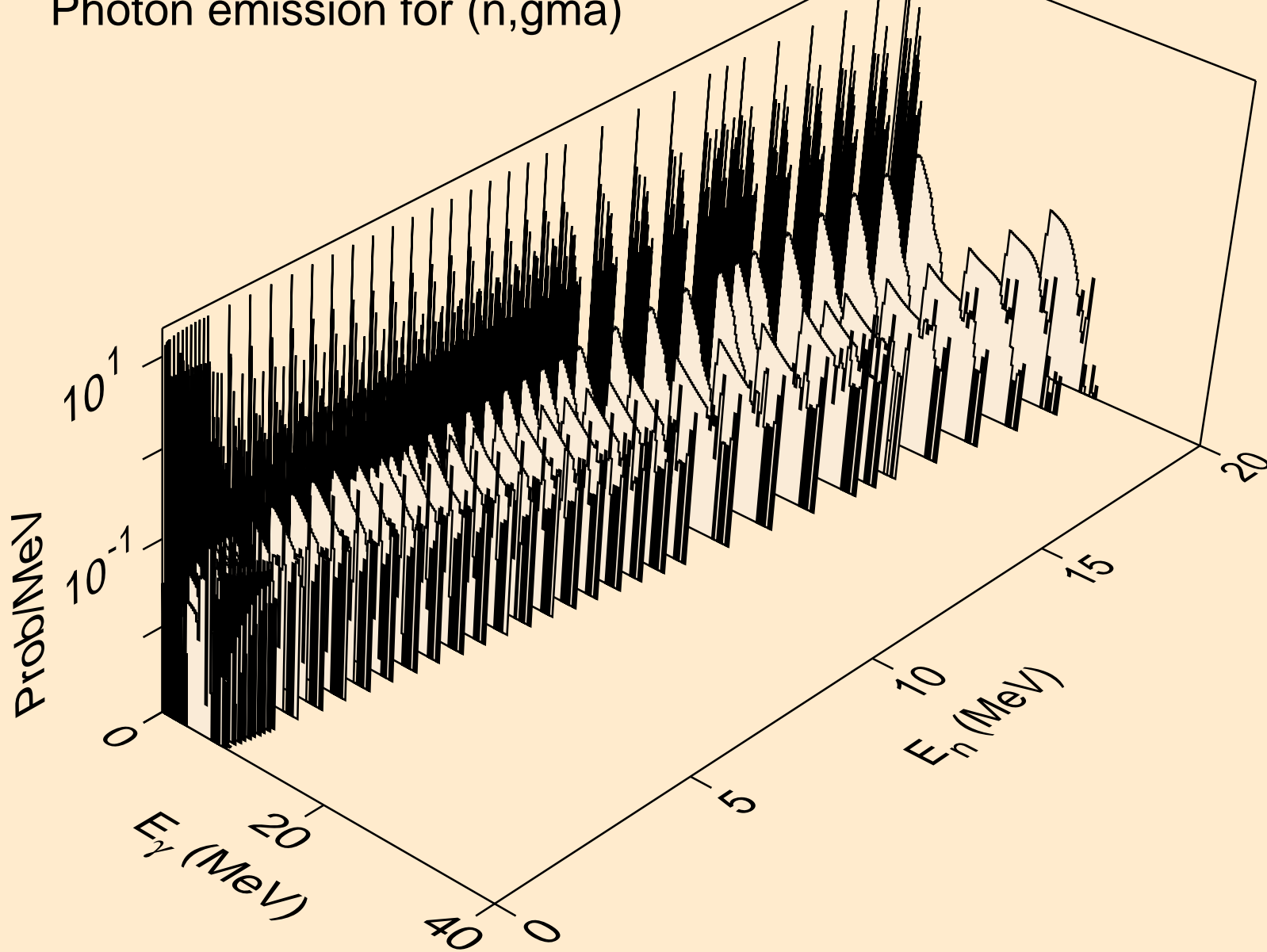

20-CA-42 FOR FENDL-3.1 FROM FENDL-3.1 WITH NJOY2012.50+  
Photon emission for (n,p\*1)

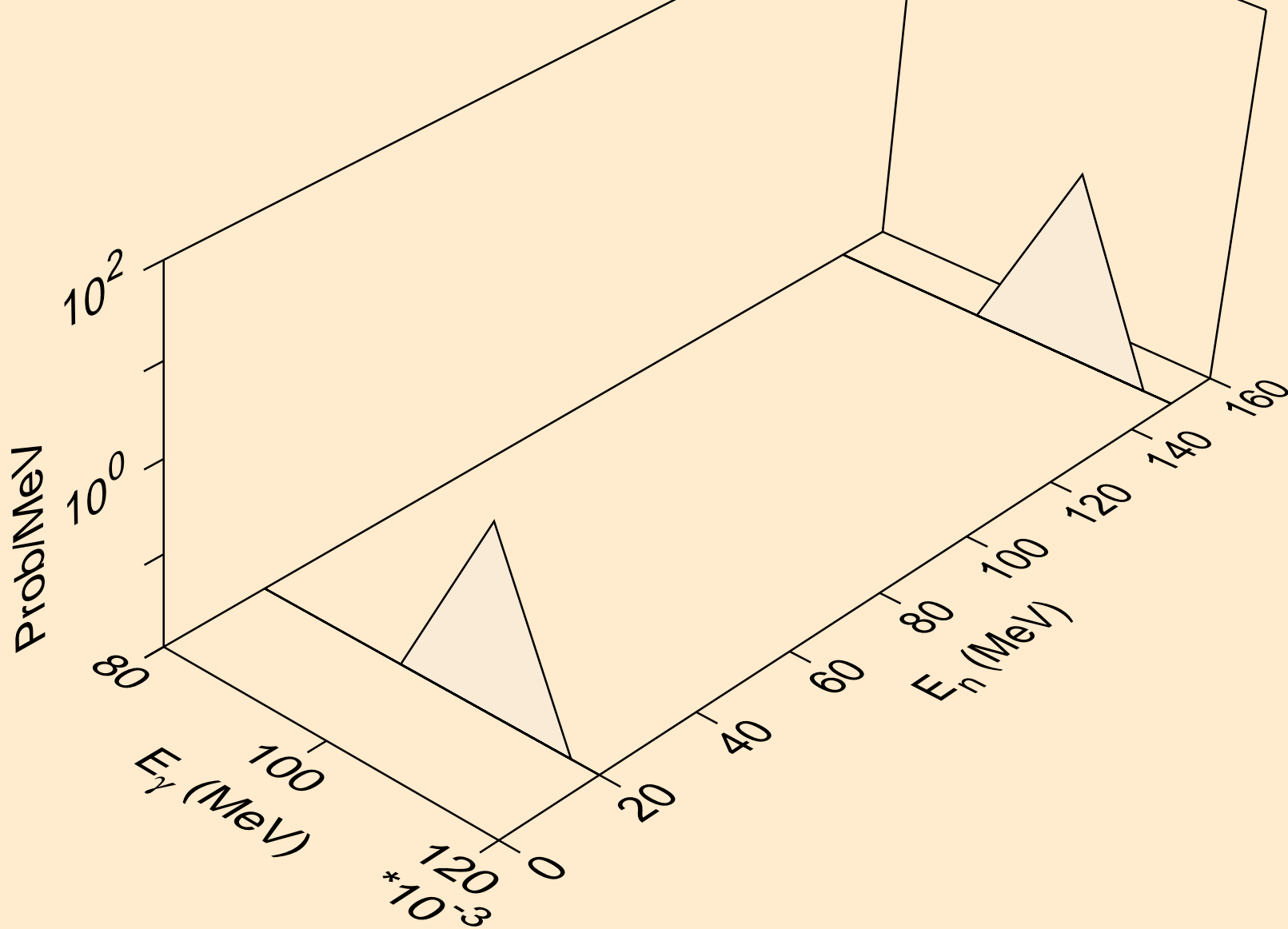

20-CA-42 FOR FENDL-3.1 FROM FENDL-3.1 WITH NJOY2012.50+  
Photon emission for (n,p\*2)

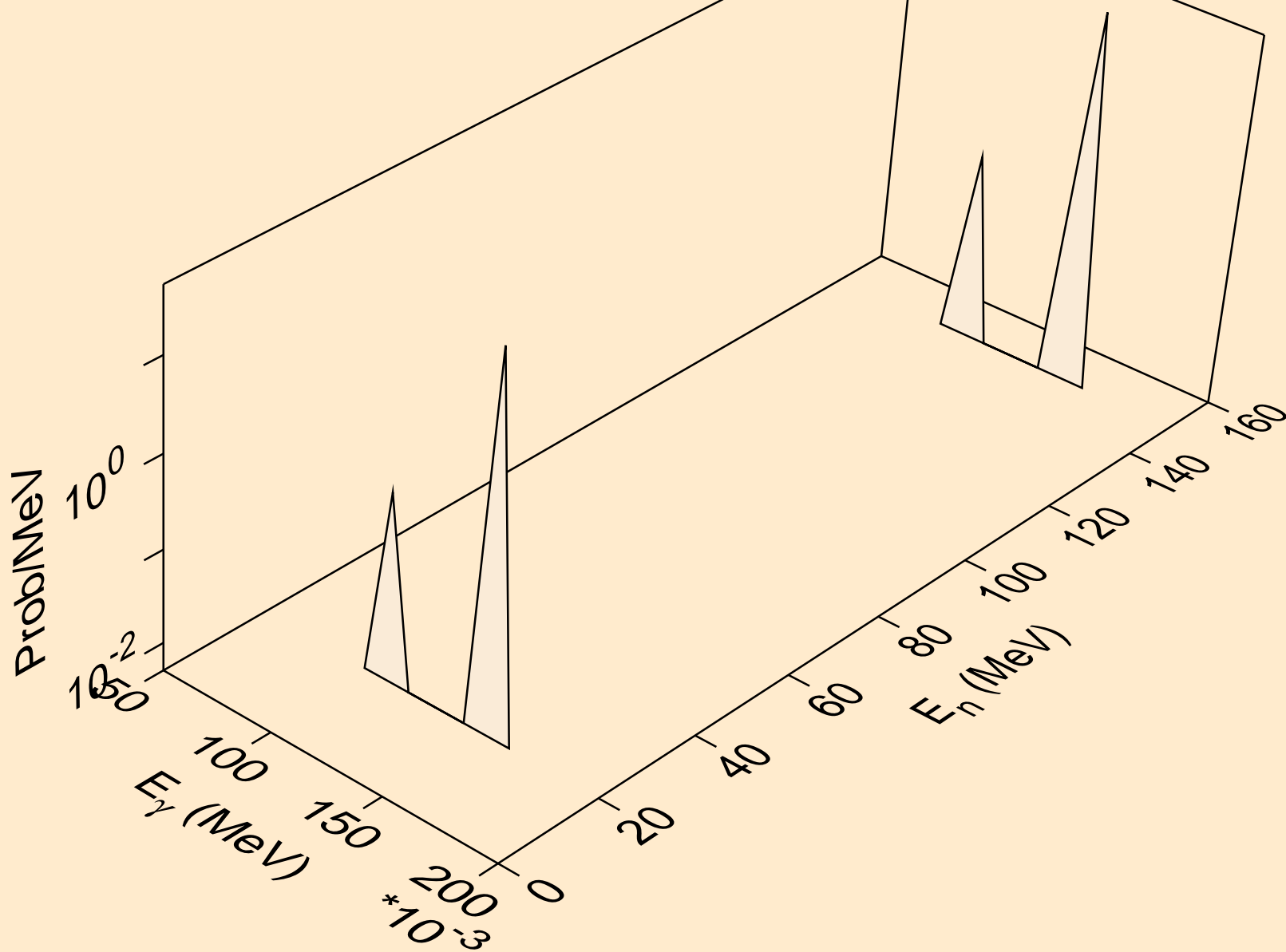

20-CA-42 FOR FENDL-3.1 FROM FENDL-3.1 WITH NJOY2012.50+  
Photon emission for (n,p\*3)

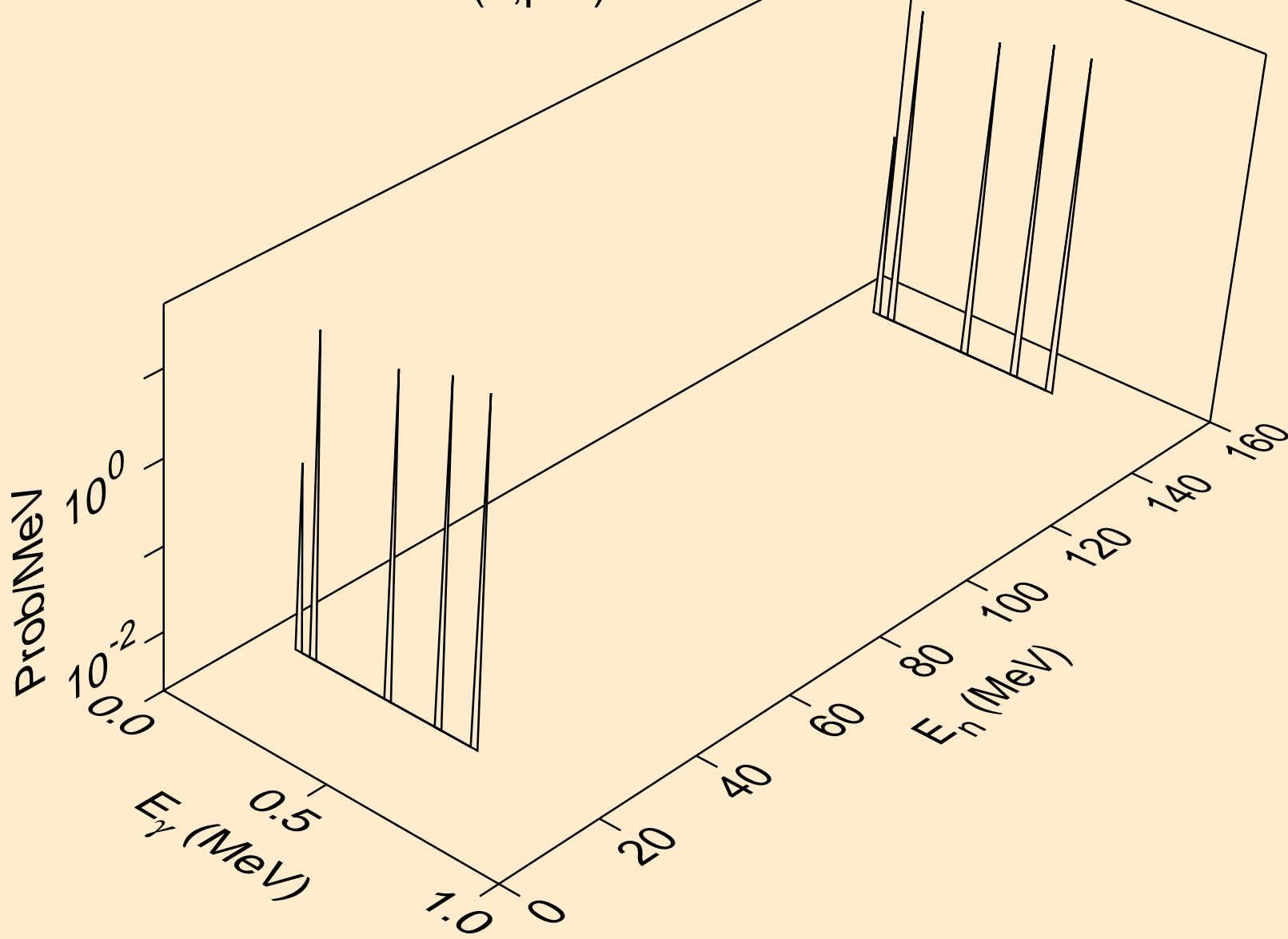



20-CA-42 FOR FENDL-3.1 FROM FENDL-3.1 WITH NJOY2012.50+  
Photon emission for (n,p\*4)

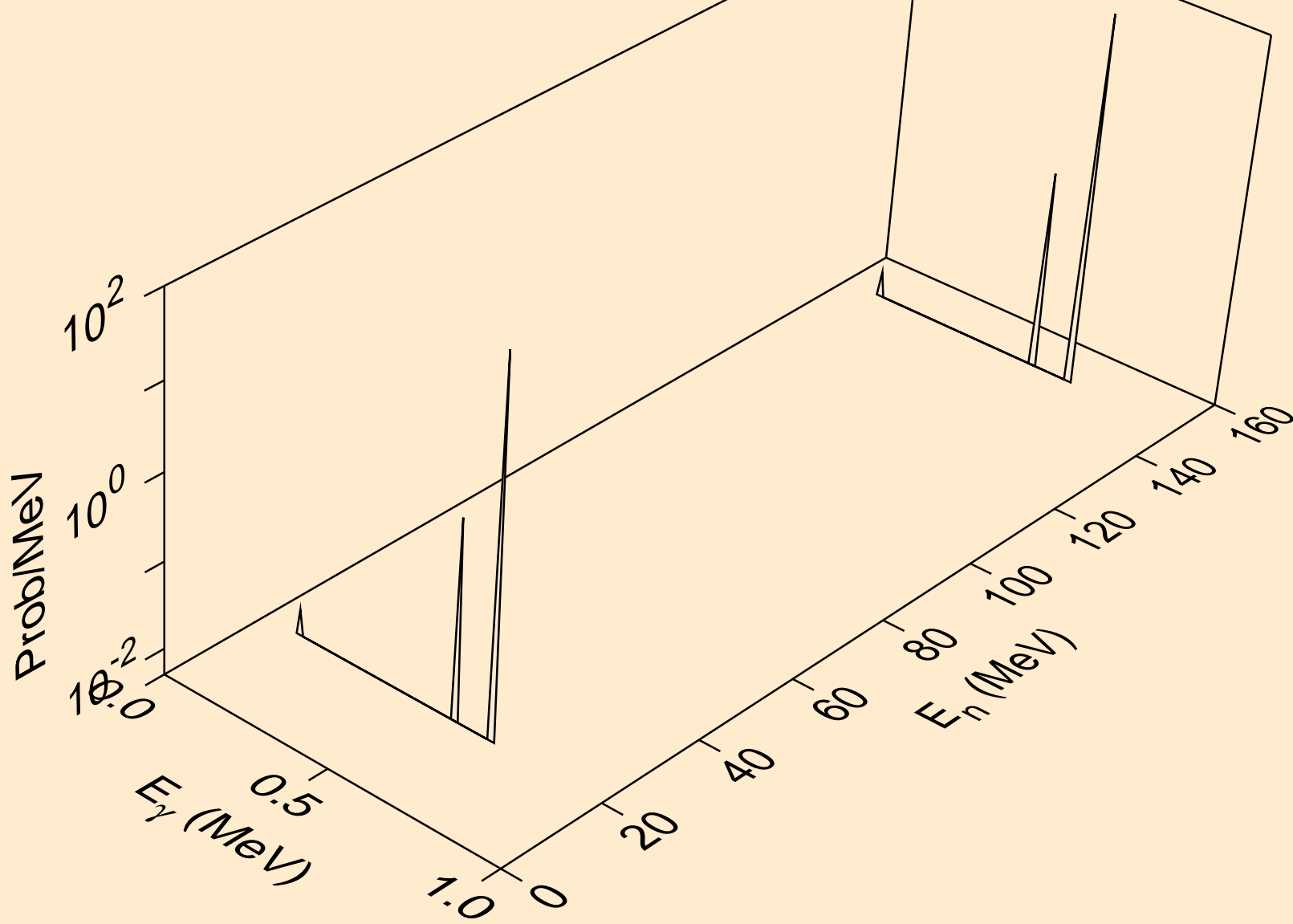

20-CA-42 FOR FENDL-3.1 FROM FENDL-3.1 WITH NJOY2012.50+  
Photon emission for (n,p\*5)

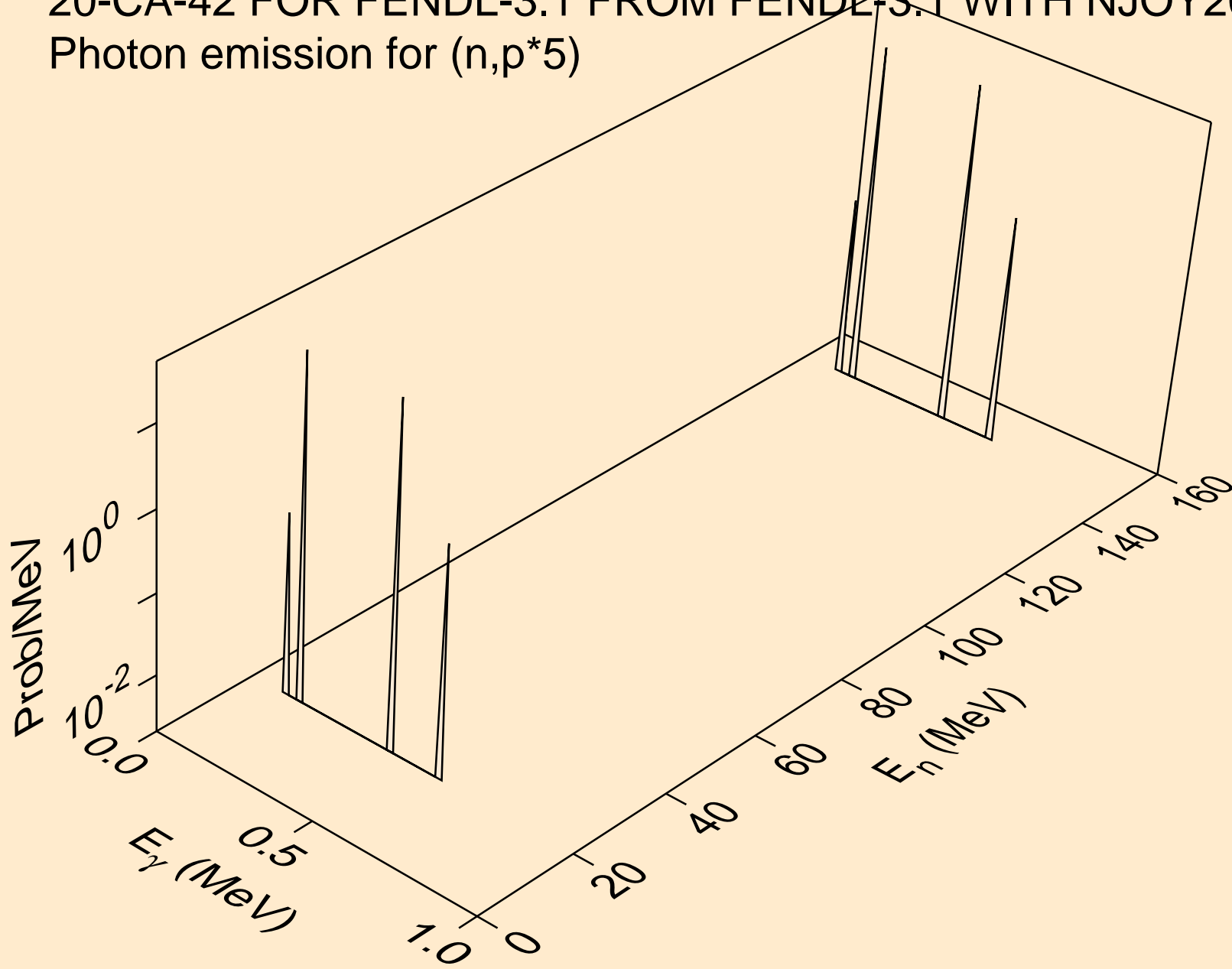

20-CA-42 FOR FENDL-3.1 FROM FENDL-3.1 WITH NJOY2012.50+  
Photon emission for (n,p\*6)

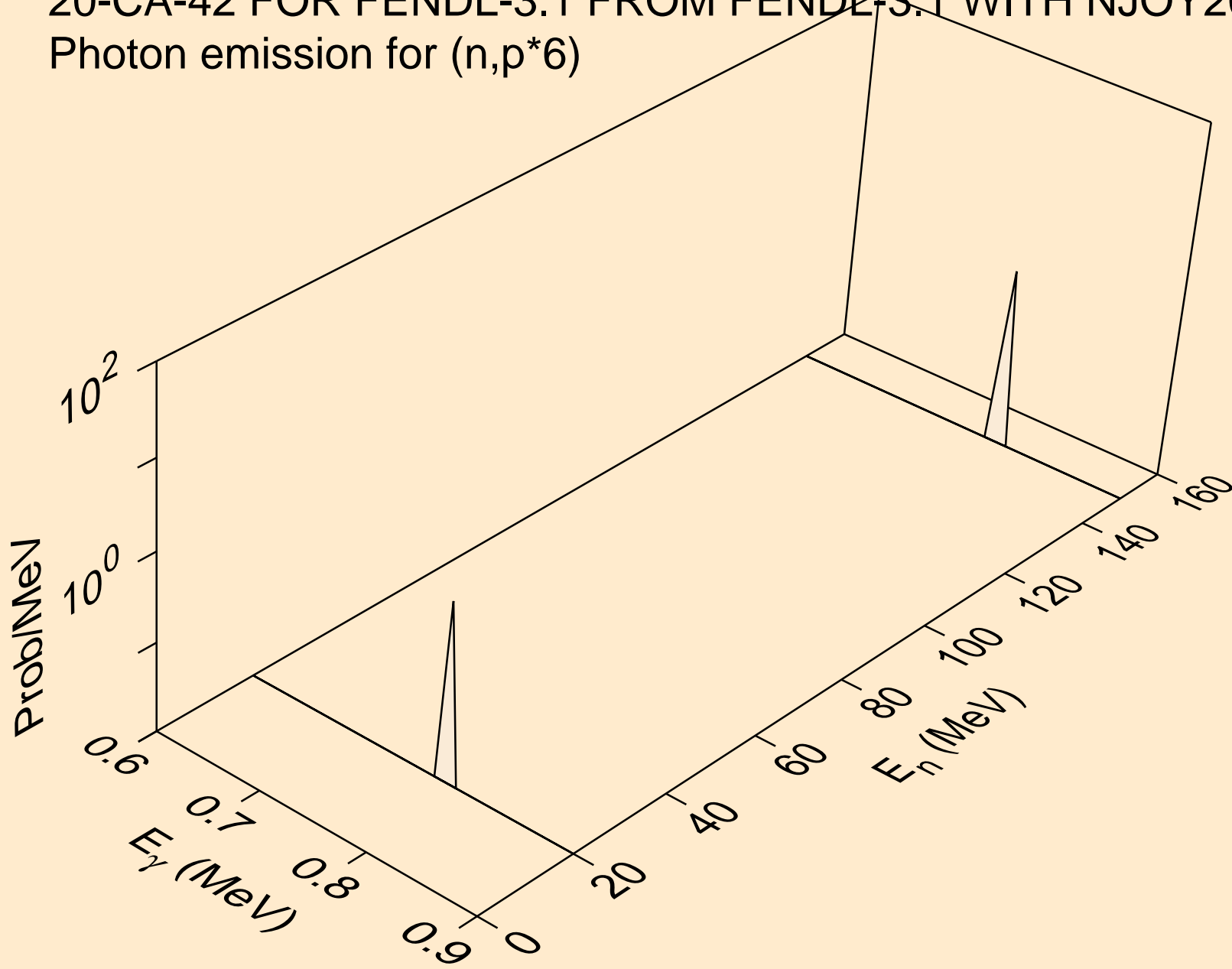

20-CA-42 FOR FENDL-3.1 FROM FENDL-3.1 WITH NJOY2012.50+  
Photon emission for (n,p\*7)

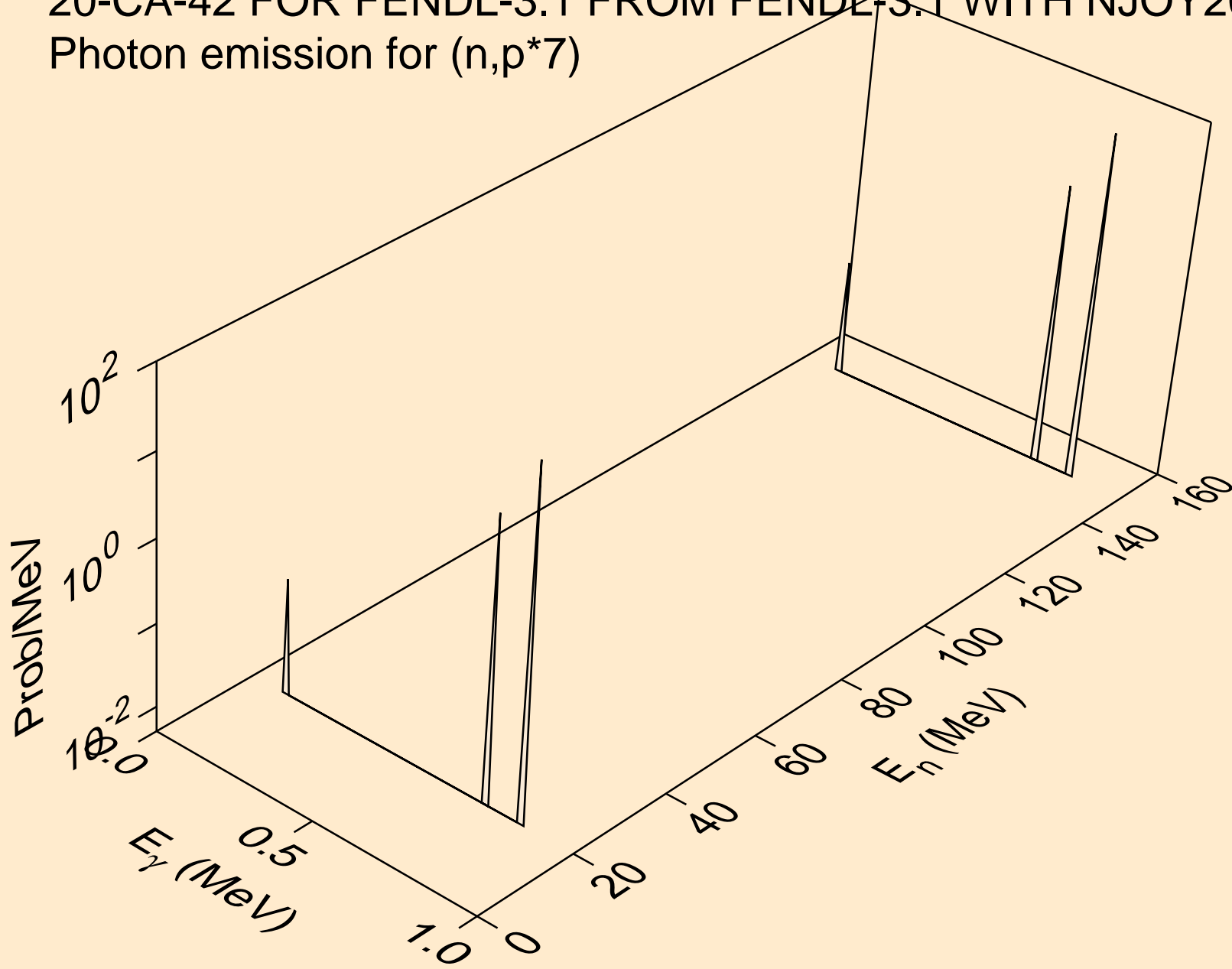

20-CA-42 FOR FENDL-3.1 FROM FENDL-3.1 WITH NJOY2012.50+  
Photon emission for (n,p\*8)

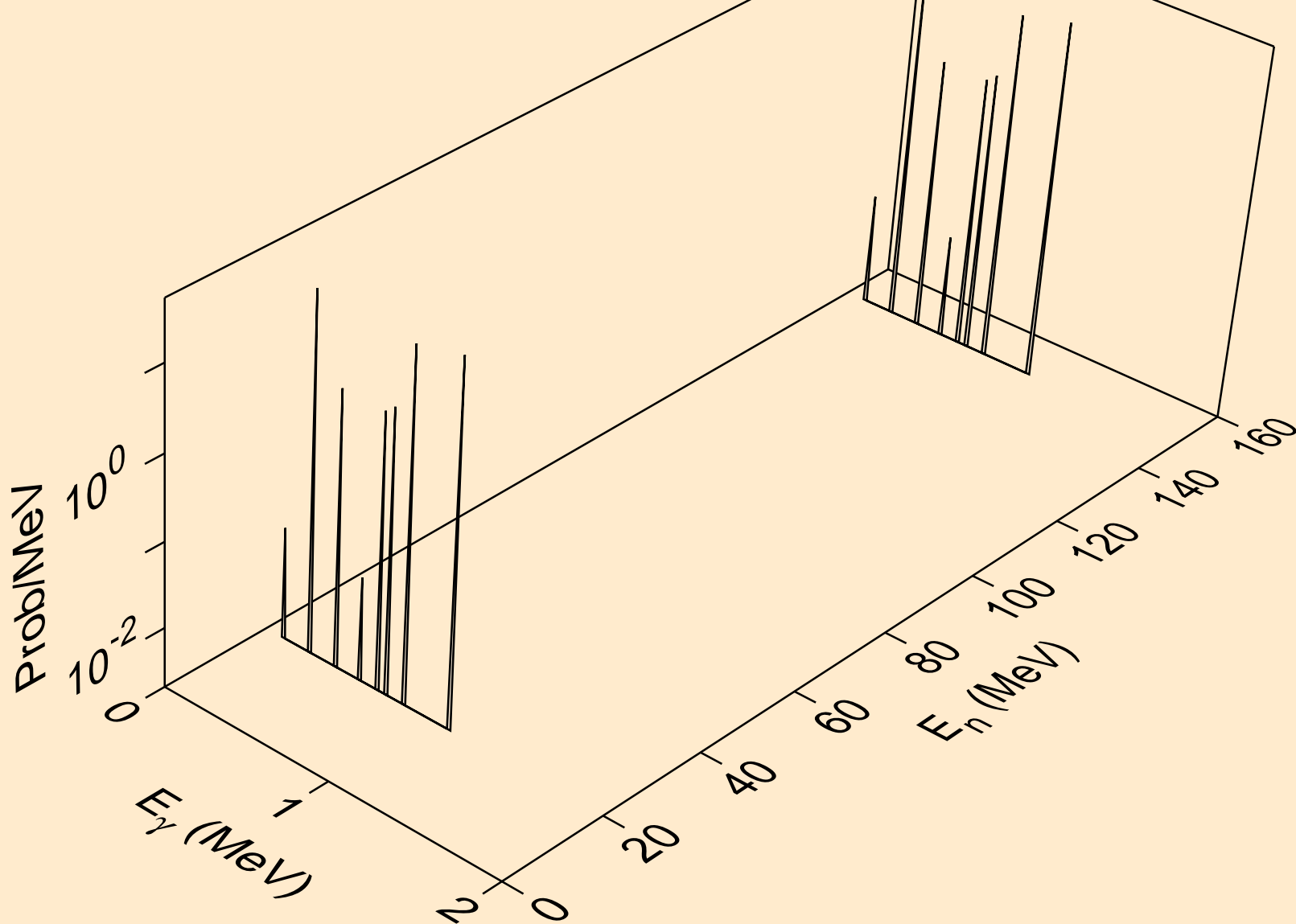

20-CA-42 FOR FENDL-3.1 FROM FENDL-3.1 WITH NJOY2012.50+  
Photon emission for (n,p\*9)

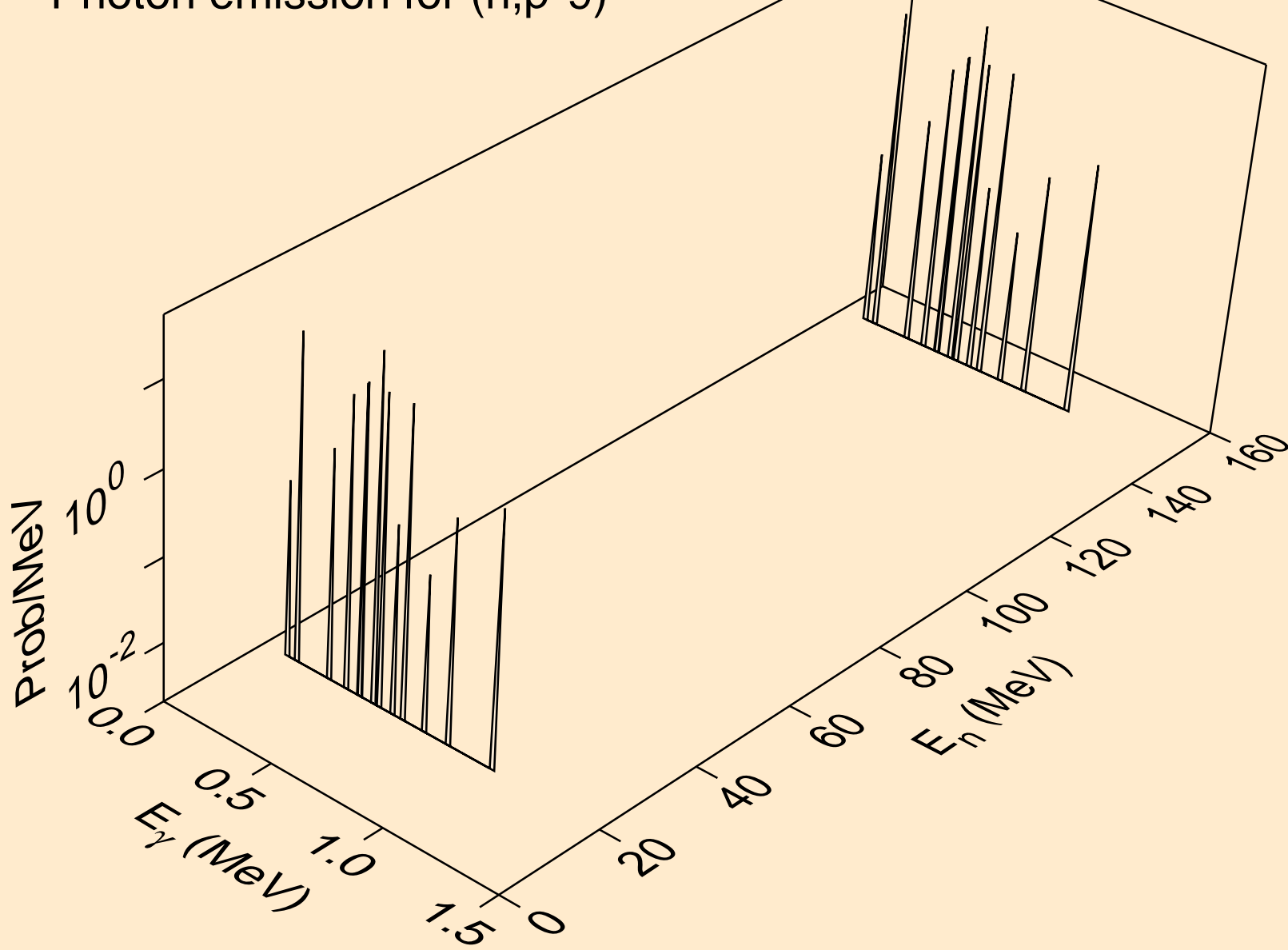

20-CA-42 FOR FENDL-3.1 FROM FENDL-3.1 WITH NJOY2012.50+  
Photon emission for (n,p\*10)

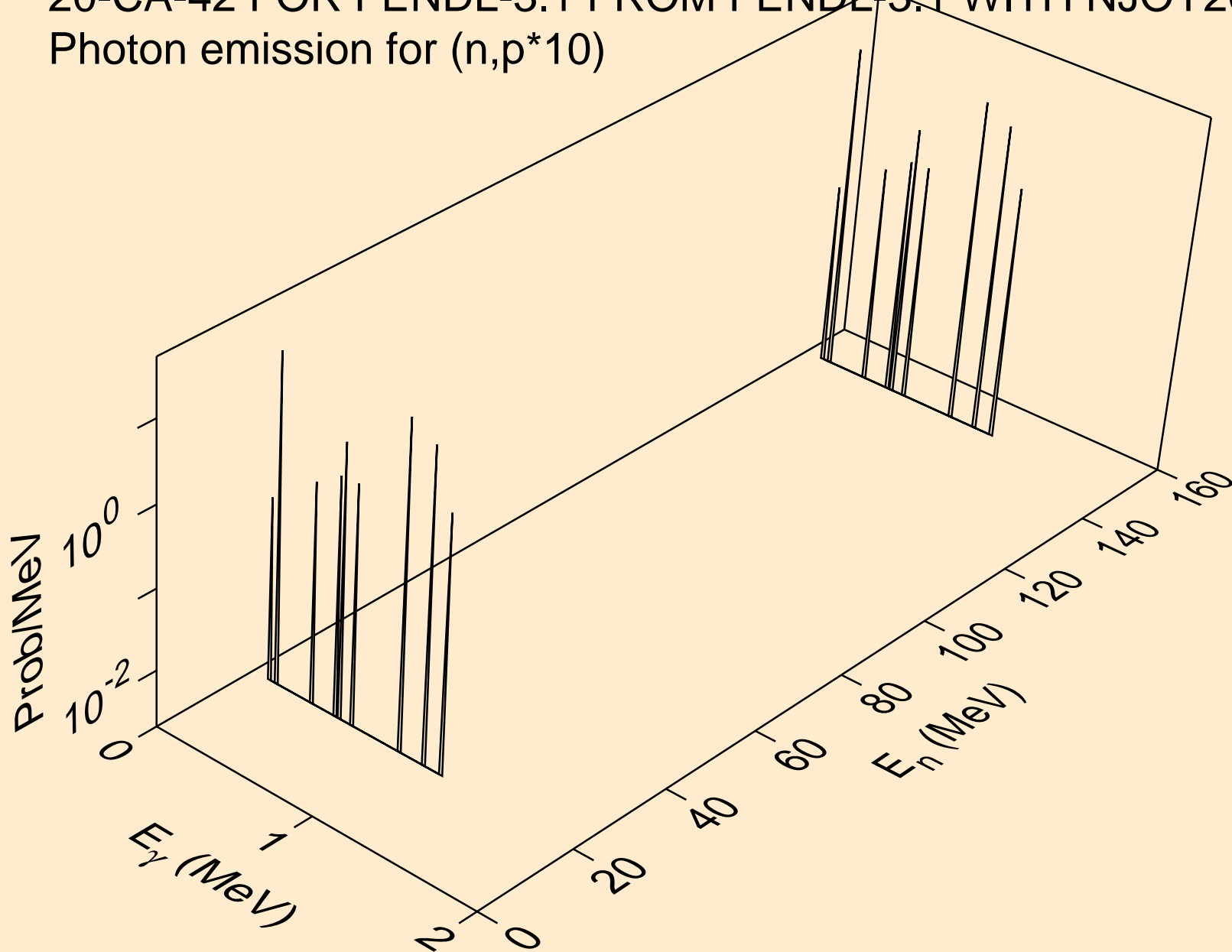

20-CA-42 FOR FENDL-3.1 FROM FENDL-3.1 WITH NJOY2012.50+  
Photon emission for (n,p\*11)

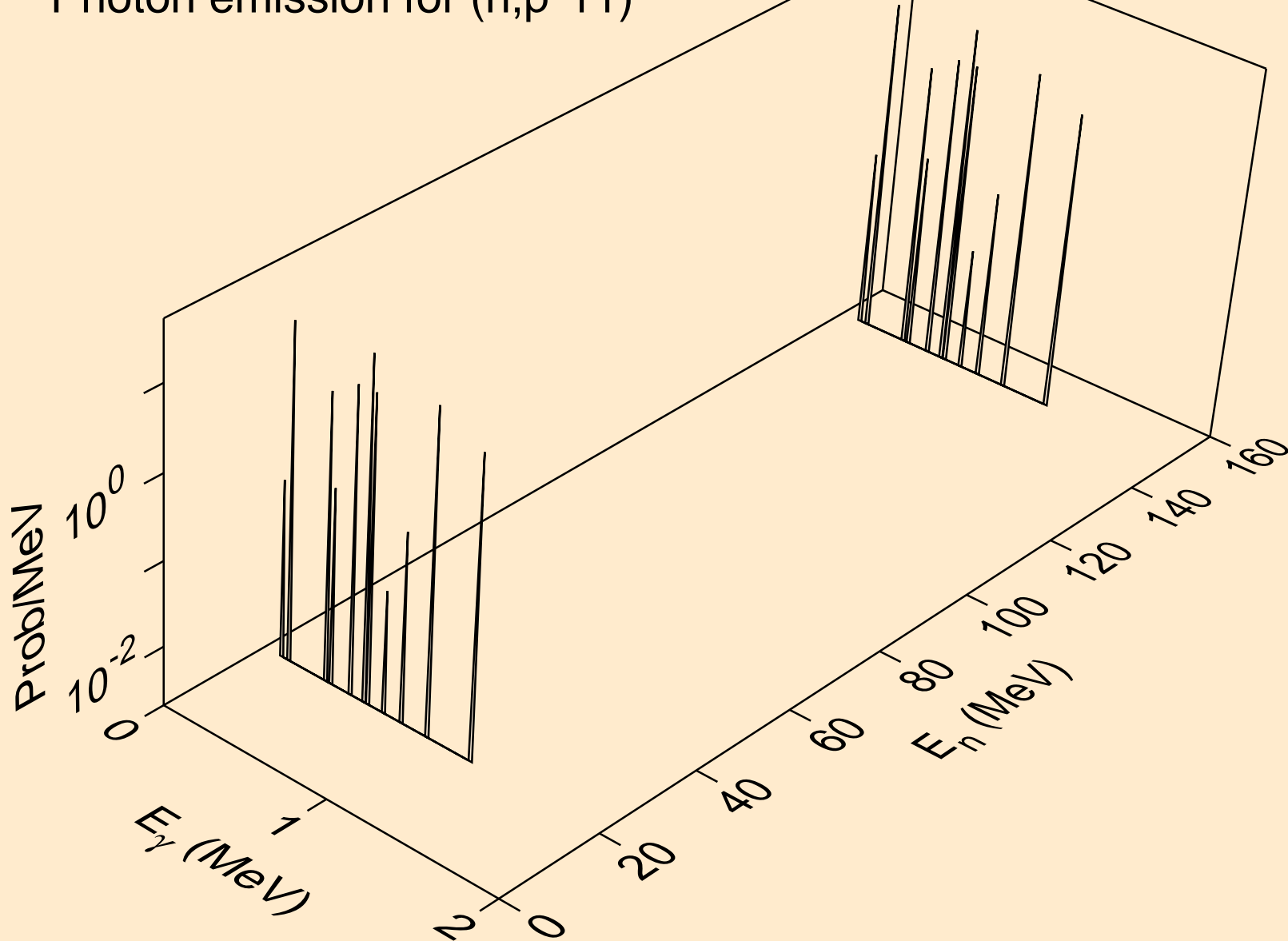



20-CA-42 FOR FENDL-3.1 FROM FENDL-3.1 WITH NJOY2012.50+  
Photon emission for (n,p\*12)

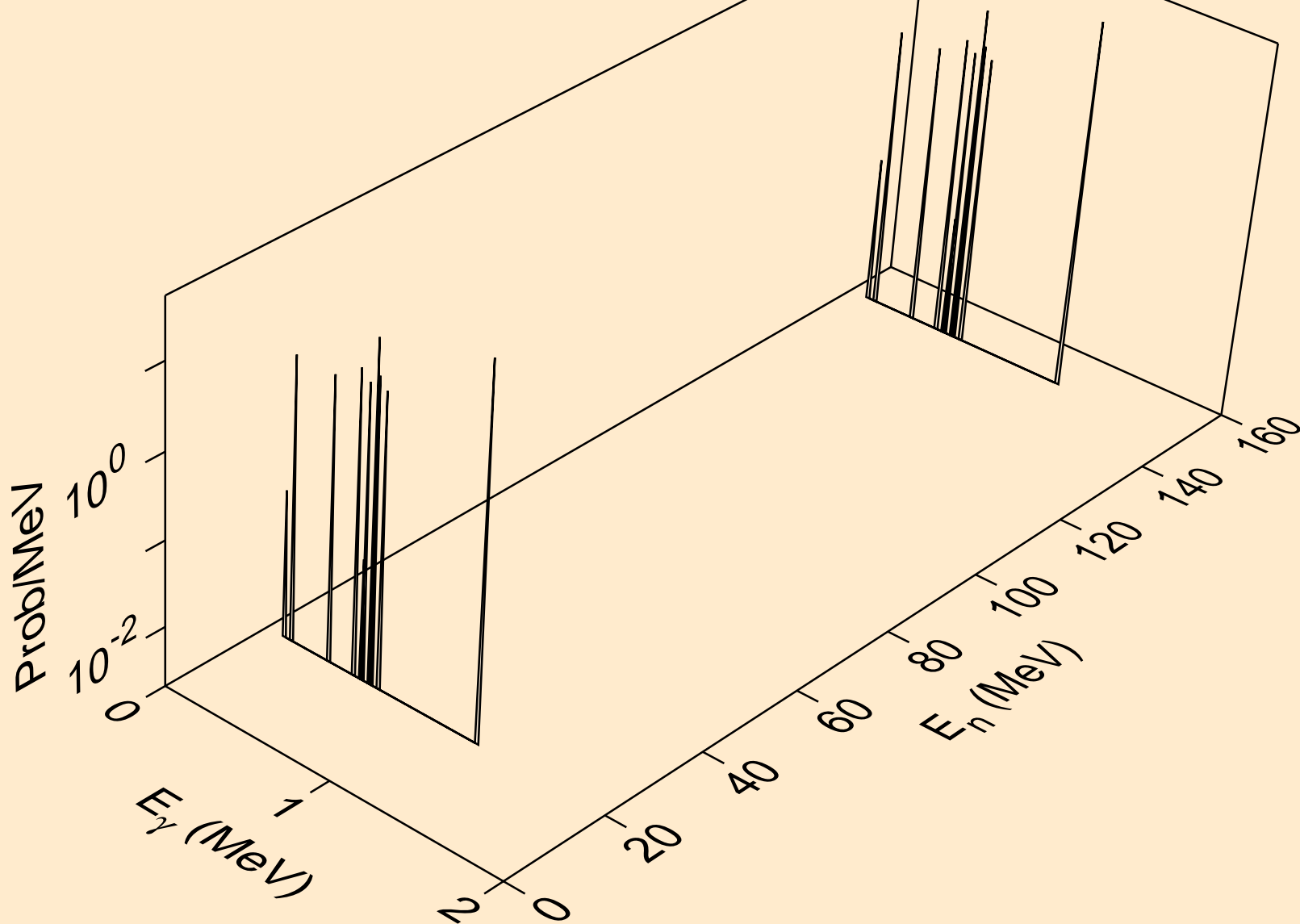

20-CA-42 FOR FENDL-3.1 FROM FENDL-3.1 WITH NJOY2012.50+  
Photon emission for (n,p\*13)

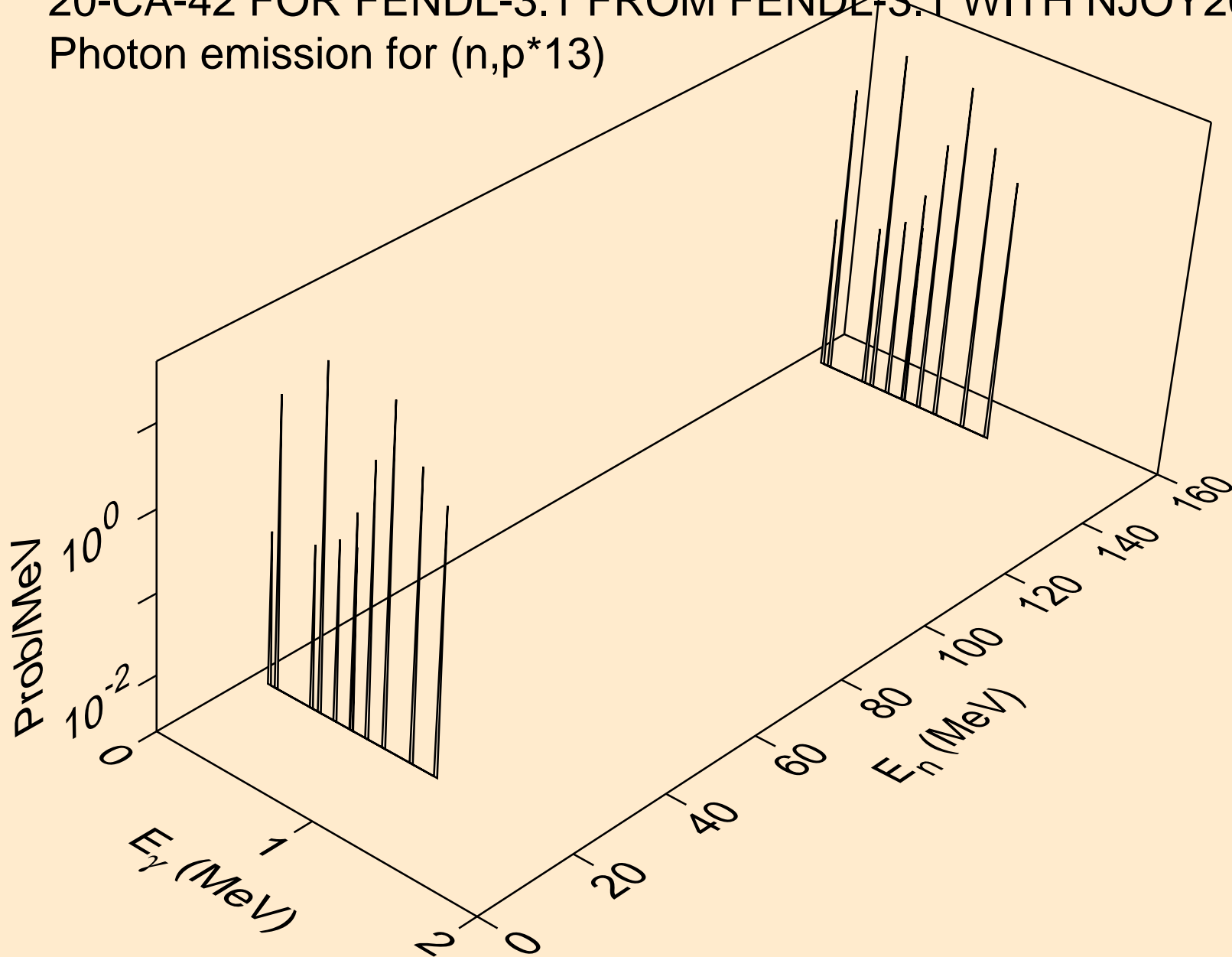

20-CA-42 FOR FENDL-3.1 FROM FENDL-3.1 WITH NJOY2012.50+  
Photon emission for (n,p\*14)

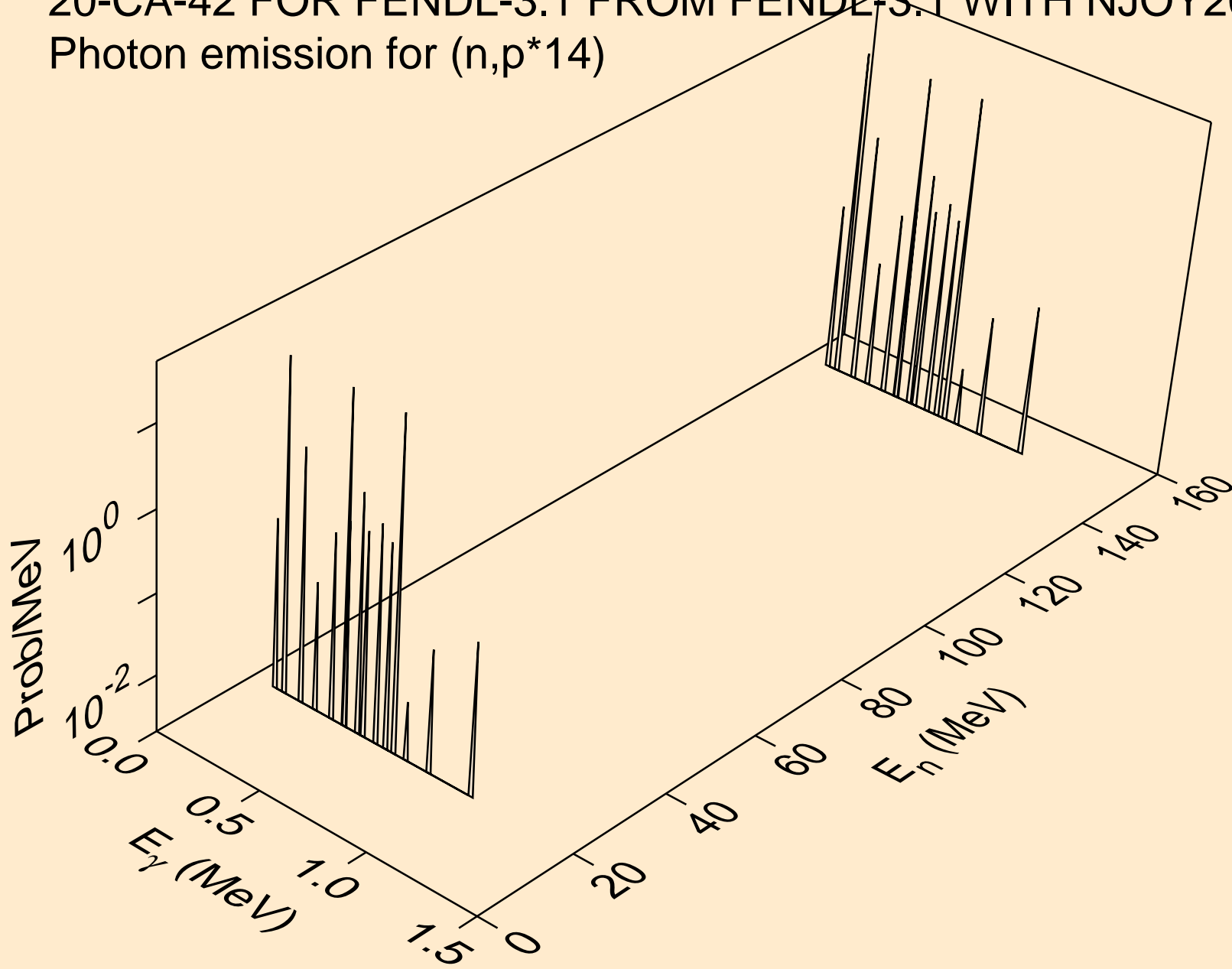

20-CA-42 FOR FENDL-3.1 FROM FENDL-3.1 WITH NJOY2012.50+  
Photon emission for (n,p\*15)

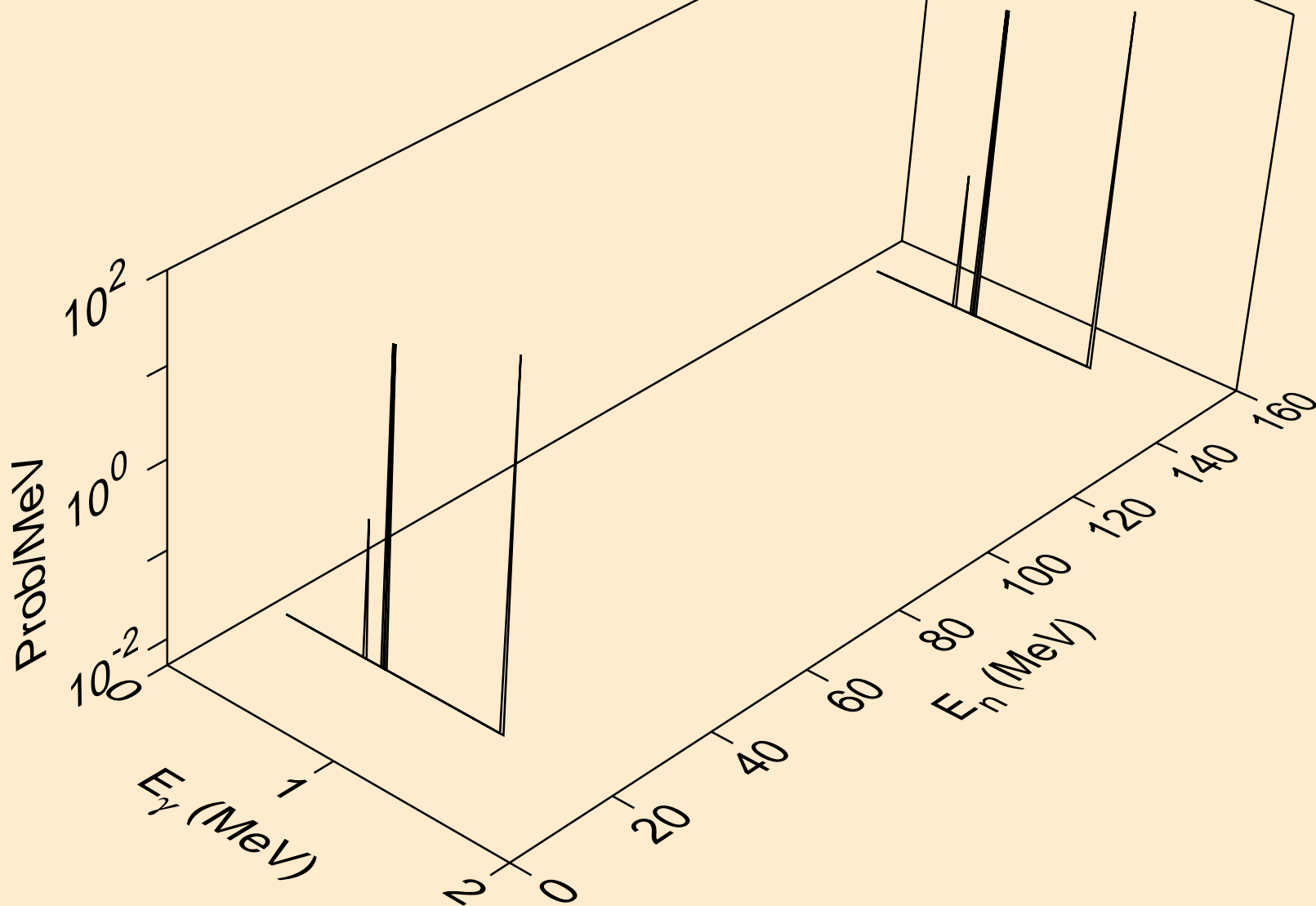

20-CA-42 FOR FENDL-3.1 FROM FENDL-3.1 WITH NJOY2012.50+  
Photon emission for (n,p\*16)

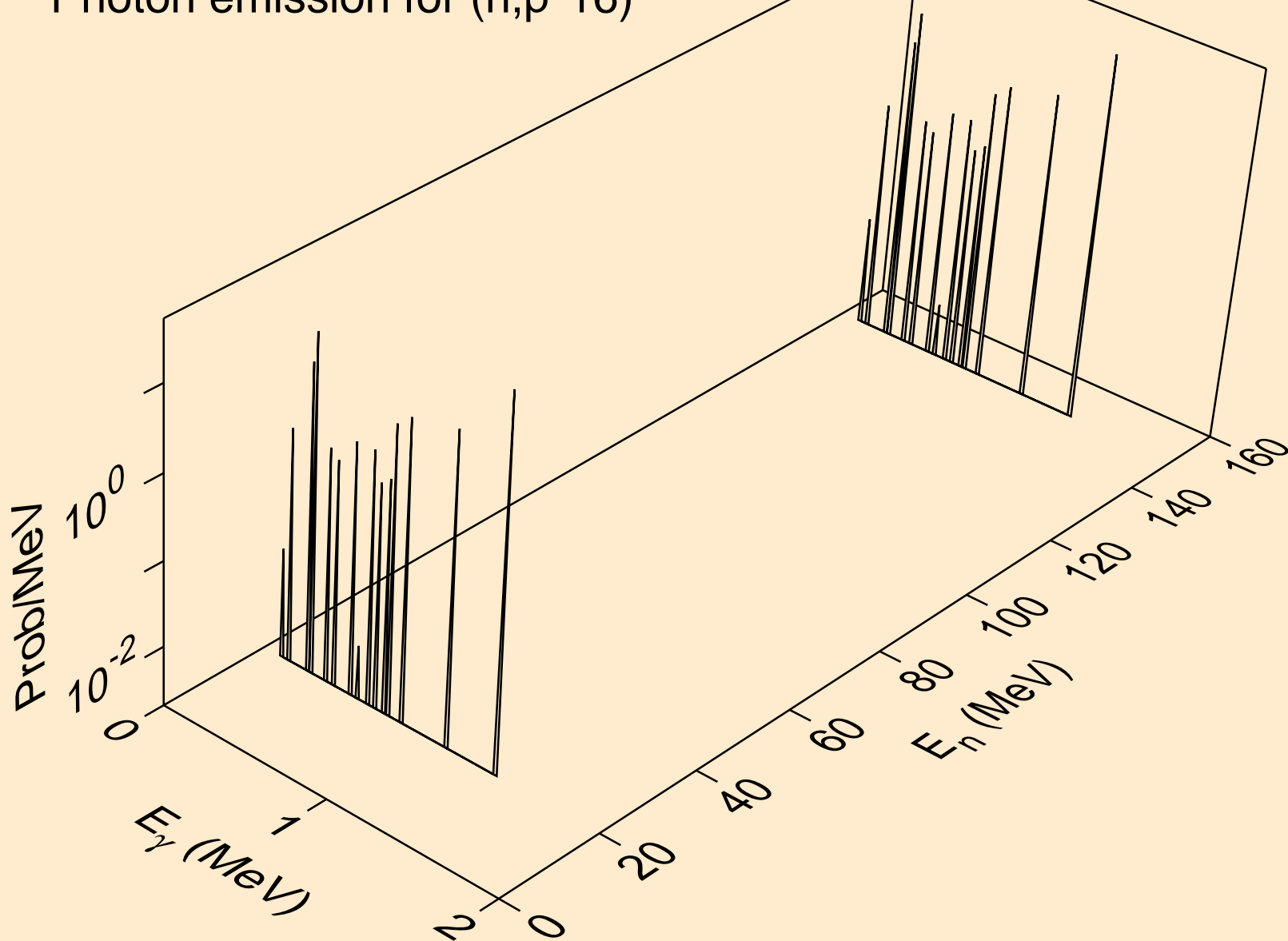

20-CA-42 FOR FENDL-3.1 FROM FENDL-3.1 WITH NJOY2012.50+  
Photon emission for (n,p\*17)

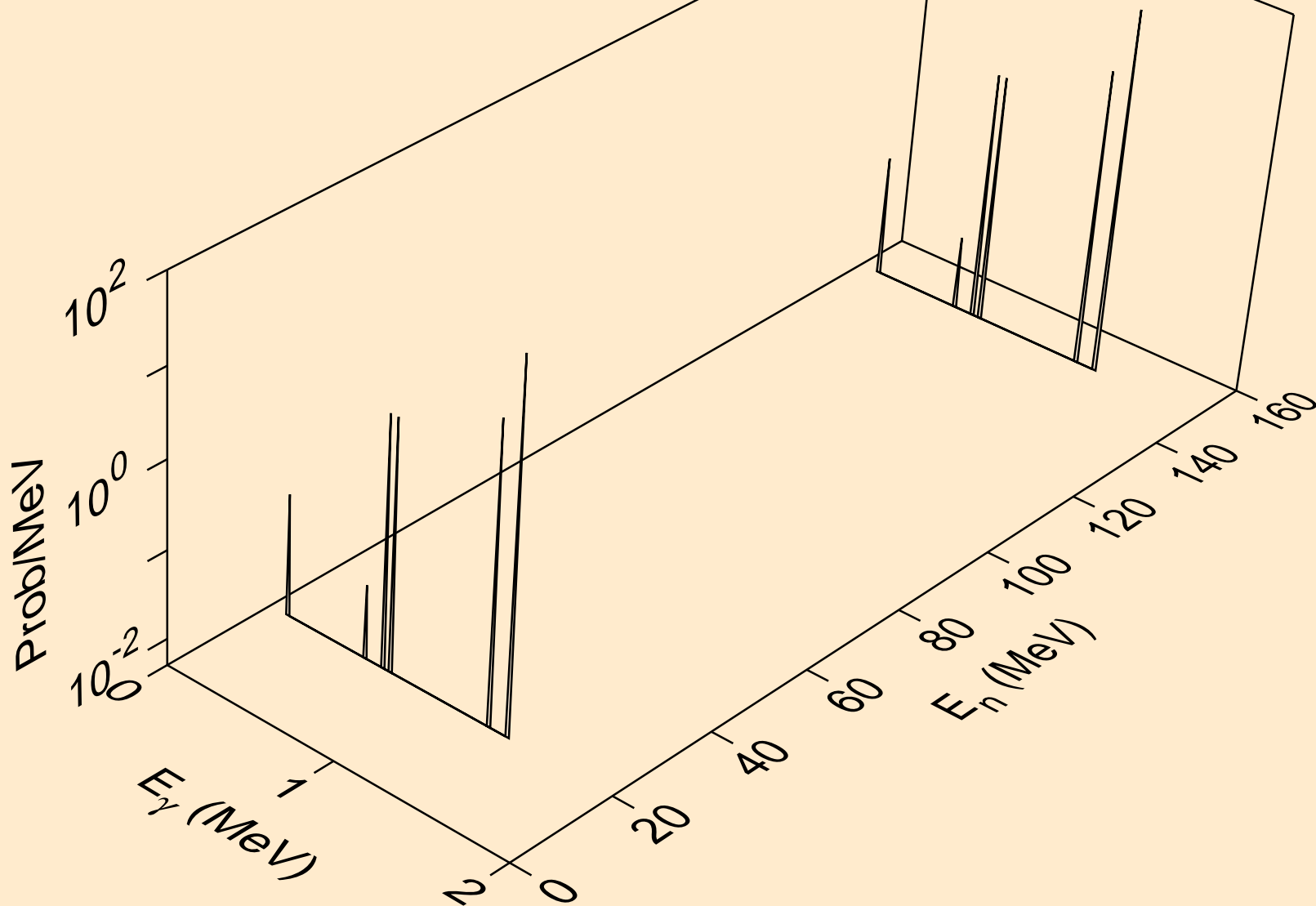

20-CA-42 FOR FENDL-3.1 FROM FENDL-3.1 WITH NJOY2012.50+  
Photon emission for (n,p\*18)

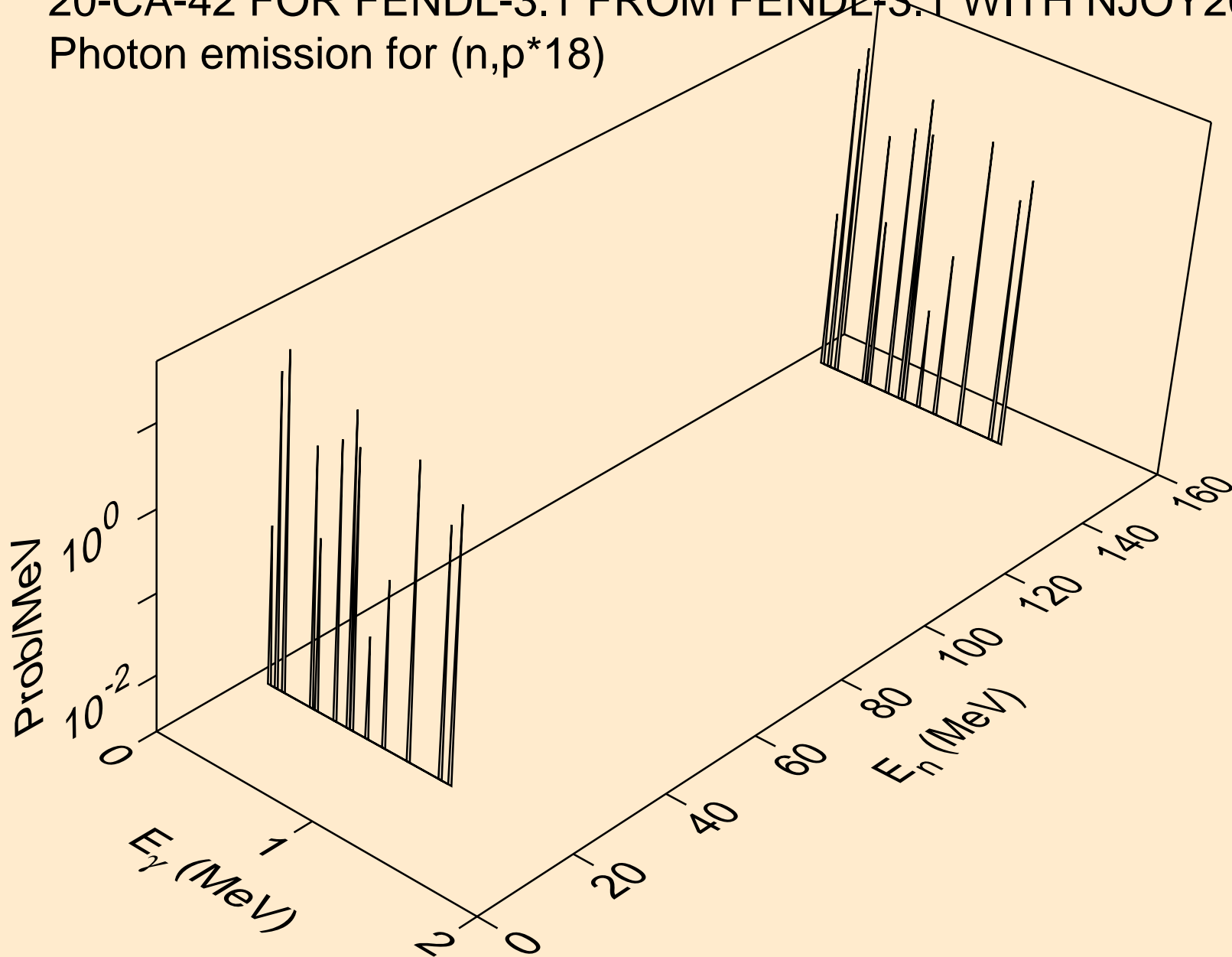

20-CA-42 FOR FENDL-3.1 FROM FENDL-3.1 WITH NJOY2012.50+  
Photon emission for (n,p\*19)

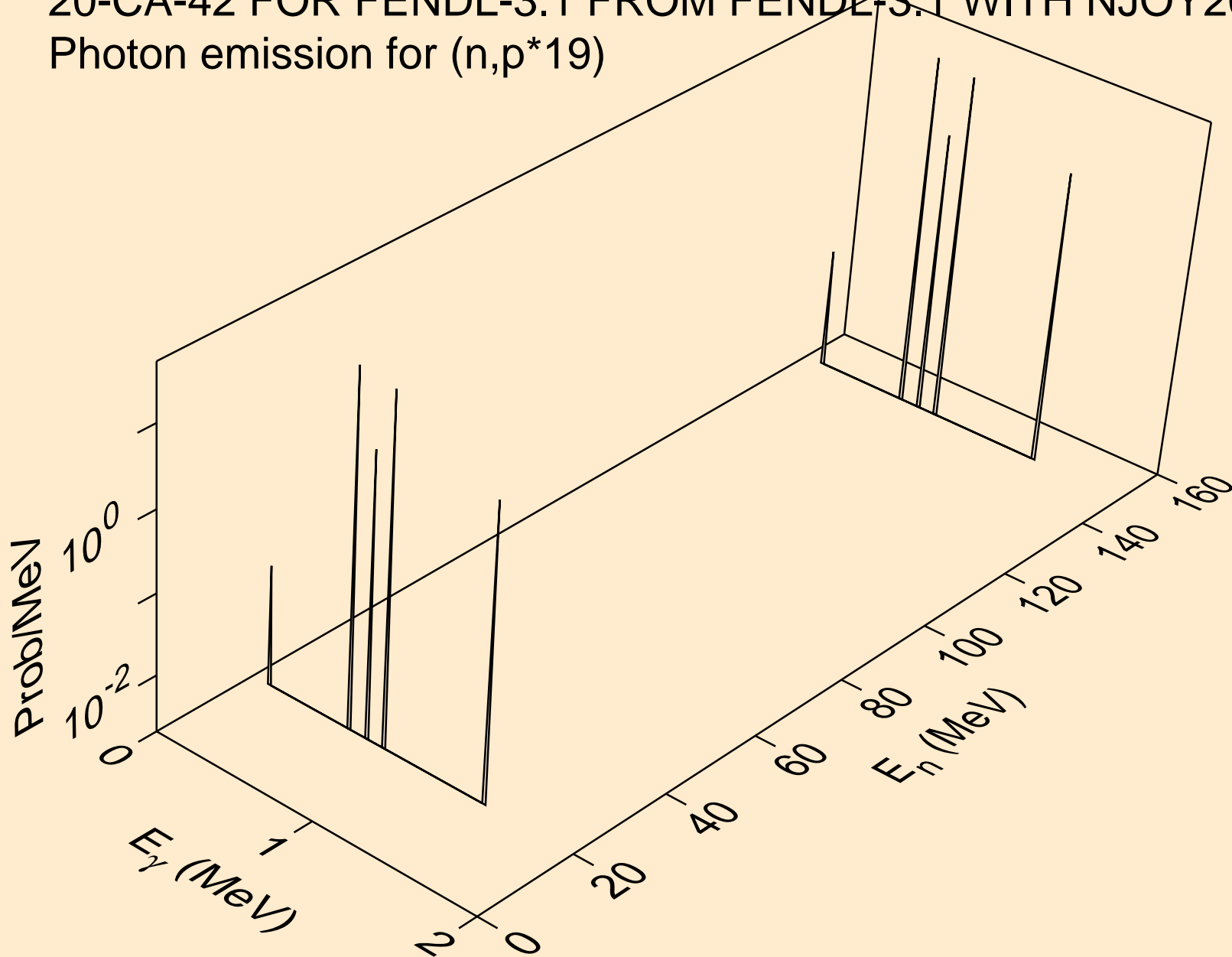



20-CA-42 FOR FENDL-3.1 FROM FENDL-3.1 WITH NJOY2012.50+  
Photon emission for (n,p\*20)

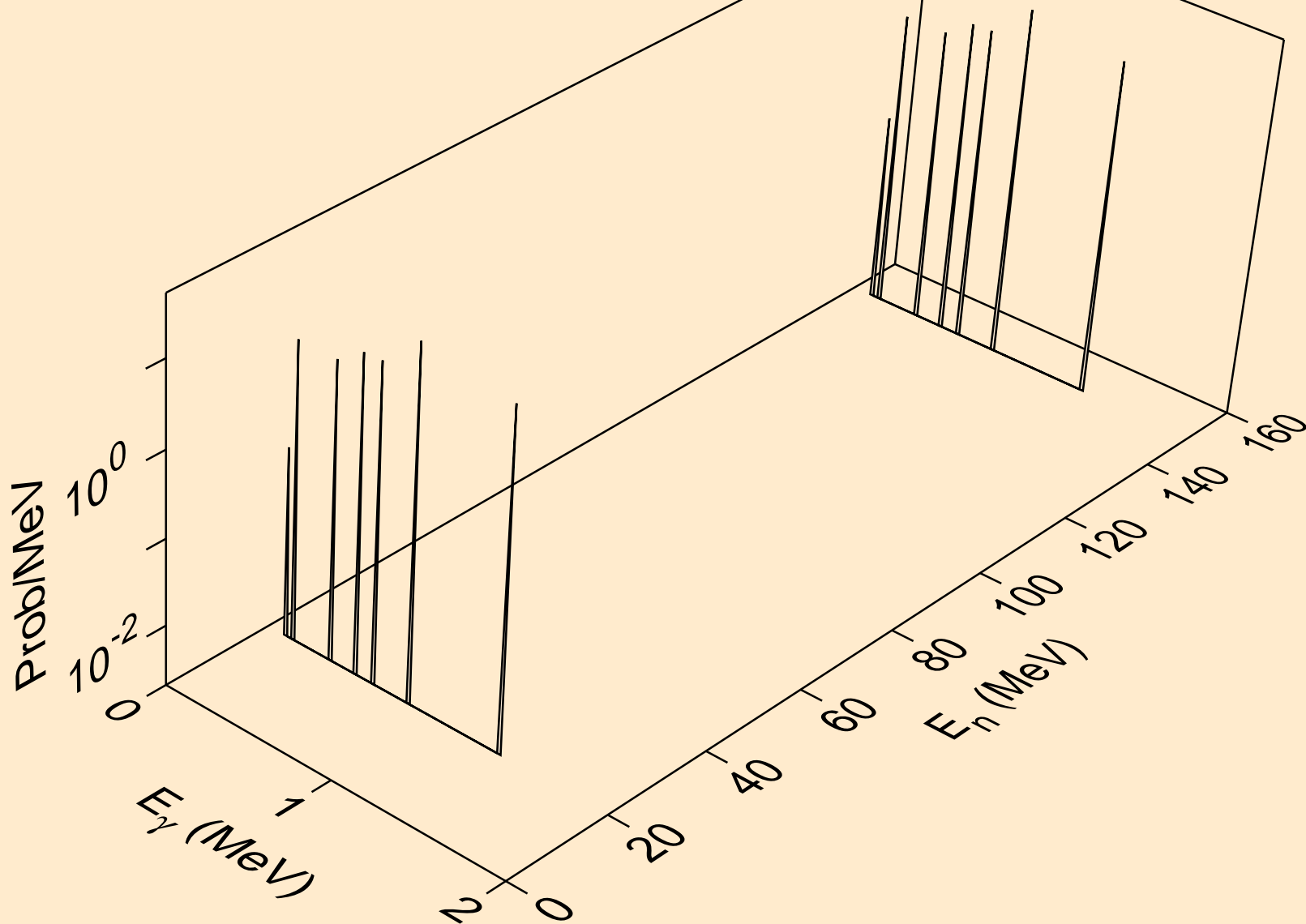

20-CA-42 FOR FENDL-3.1 FROM FENDL-3.1 WITH NJOY2012.50+  
Photon emission for (n,p\*21)

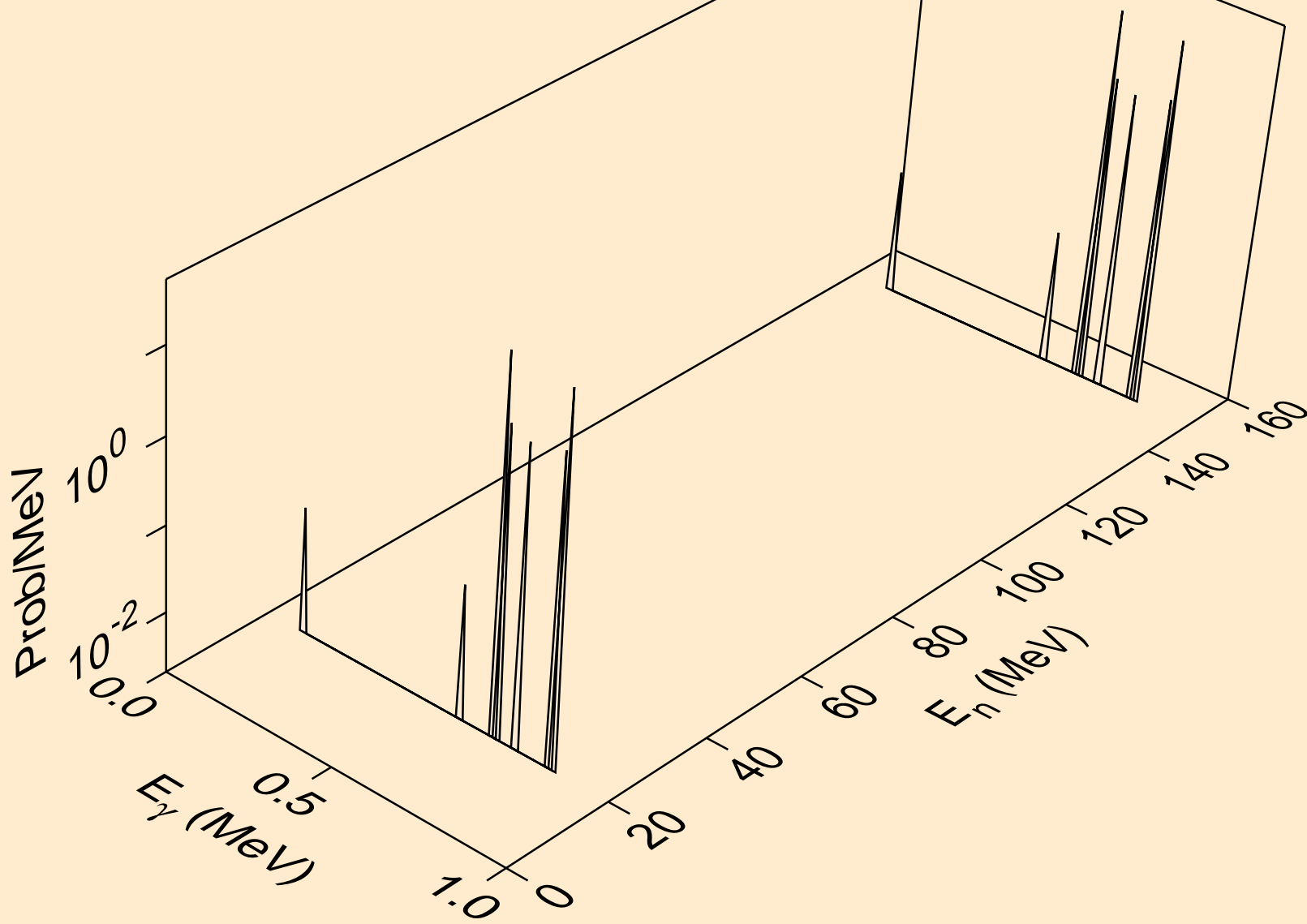

20-CA-42 FOR FENDL-3.1 FROM FENDL-3.1 WITH NJOY2012.50+  
Photon emission for (n,p\*22)

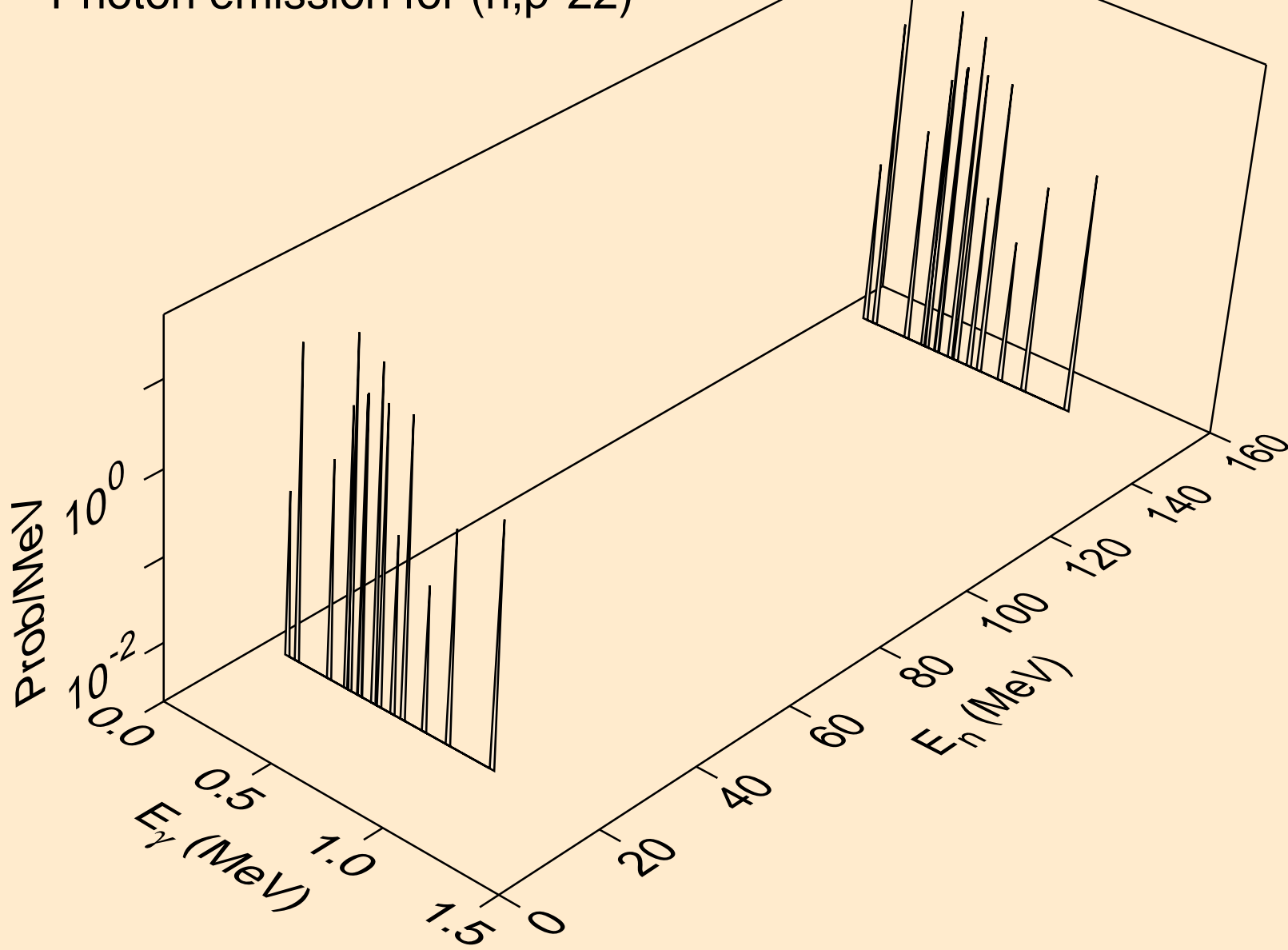

20-CA-42 FOR FENDL-3.1 FROM FENDL-3.1 WITH NJOY2012.50+  
Photon emission for (n,p\*23)

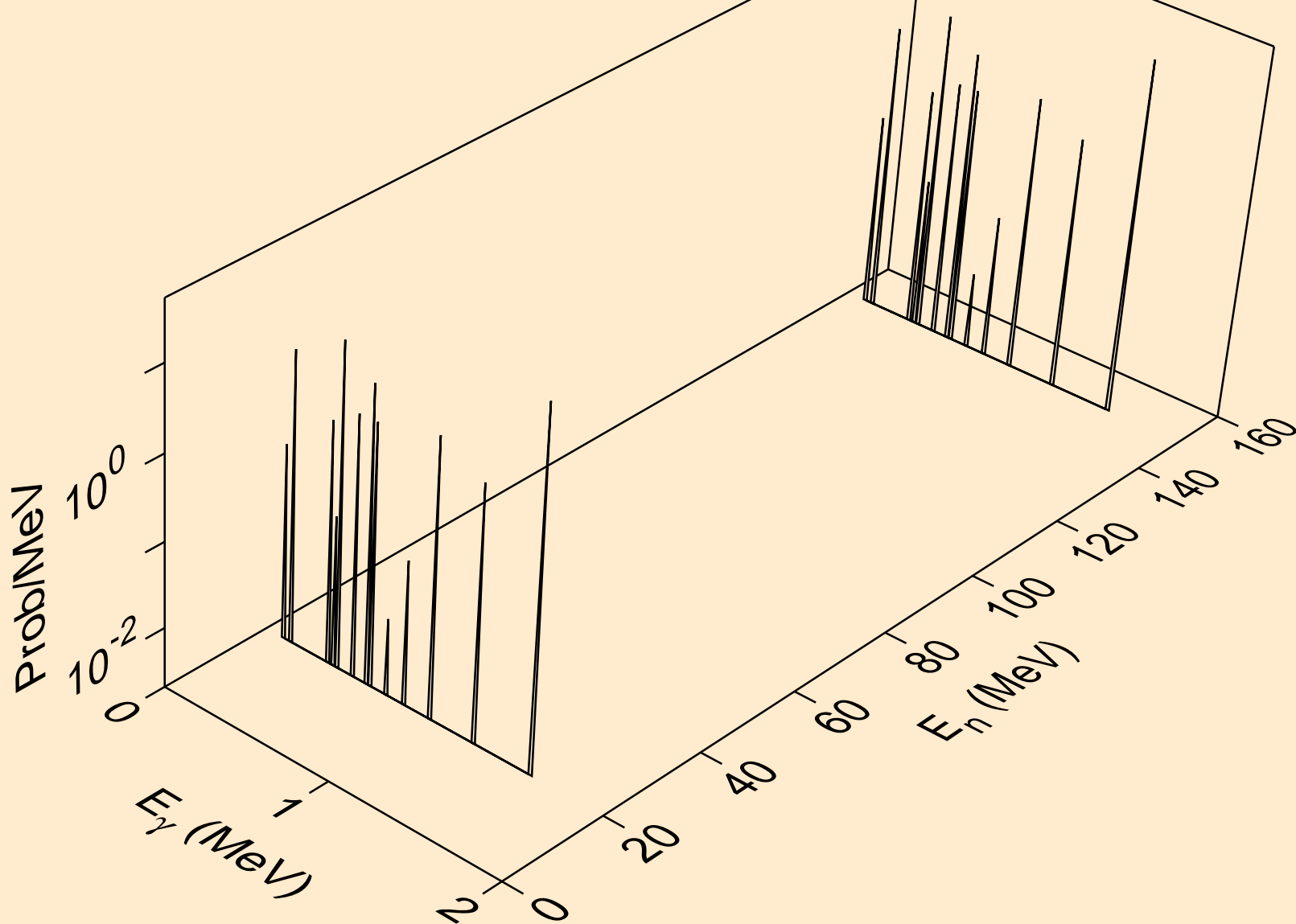

20-CA-42 FOR FENDL-3.1 FROM FENDL-3.1 WITH NJOY2012.50+  
Photon emission for (n,p\*24)

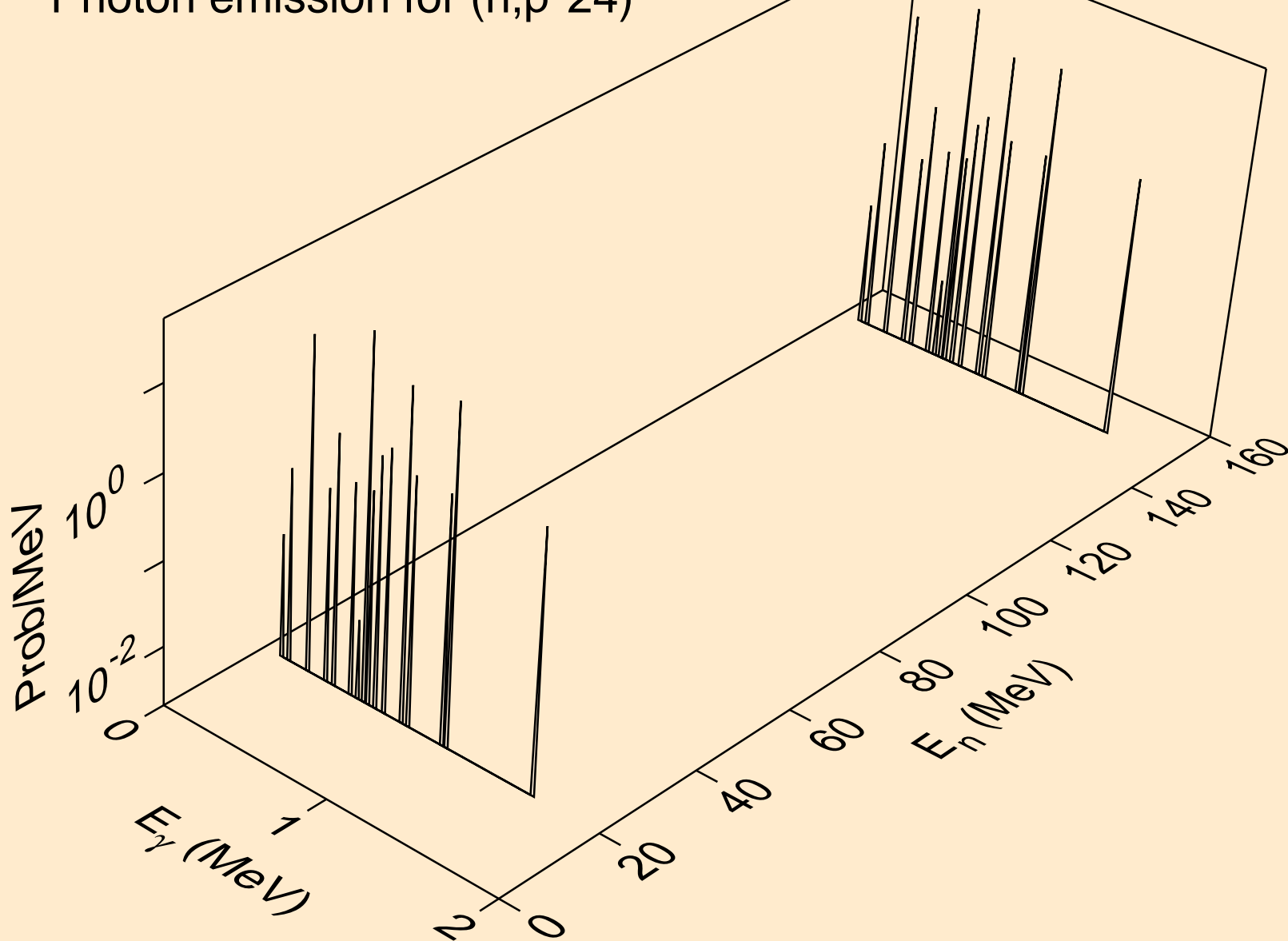

20-CA-42 FOR FENDL-3.1 FROM FENDL-3.1 WITH NJOY2012.50+  
Photon emission for (n,p\*25)

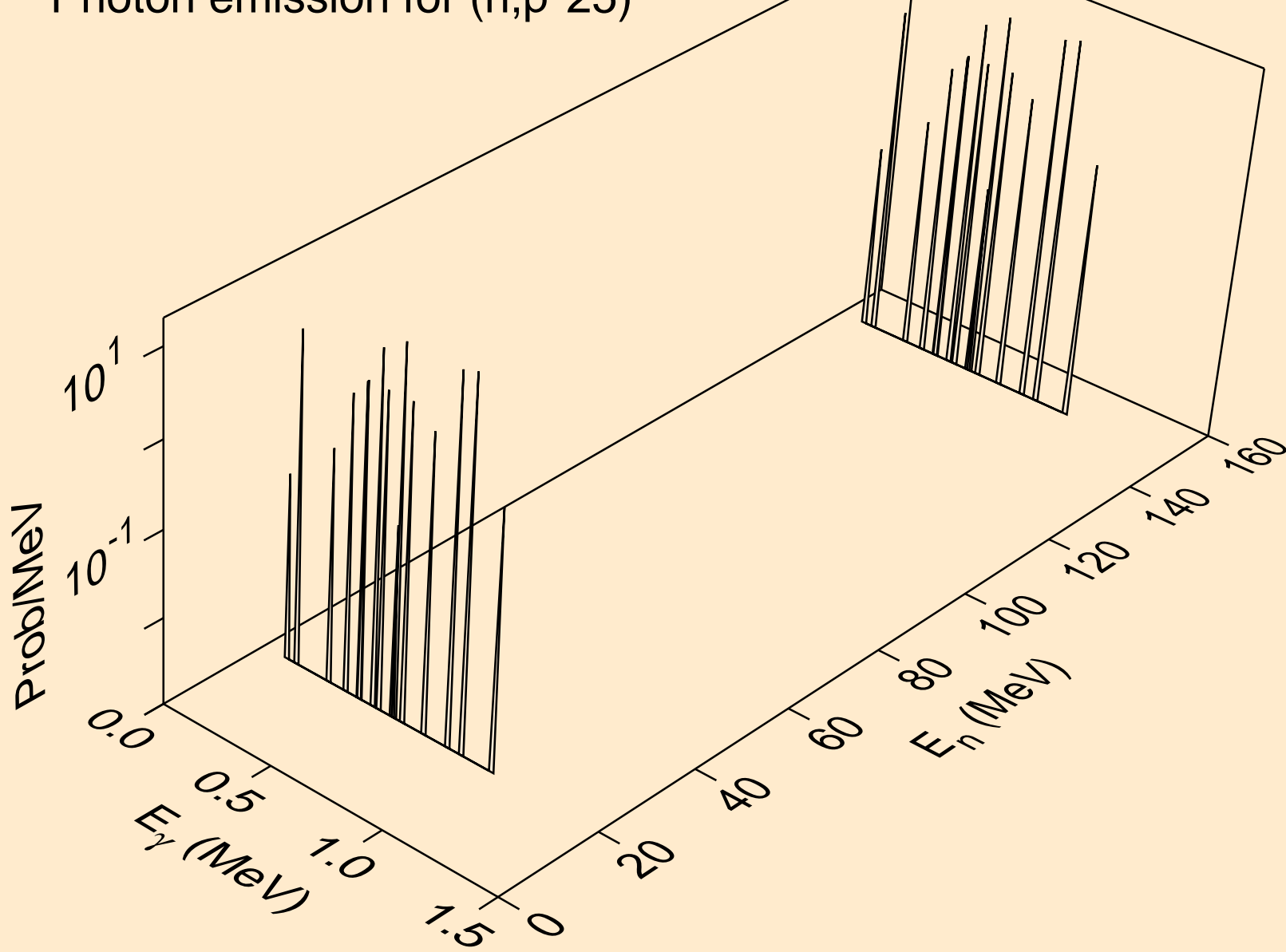

20-CA-42 FOR FENDL-3.1 FROM FENDL-3.1 WITH NJOY2012.50+  
Photon emission for (n,p\*27)

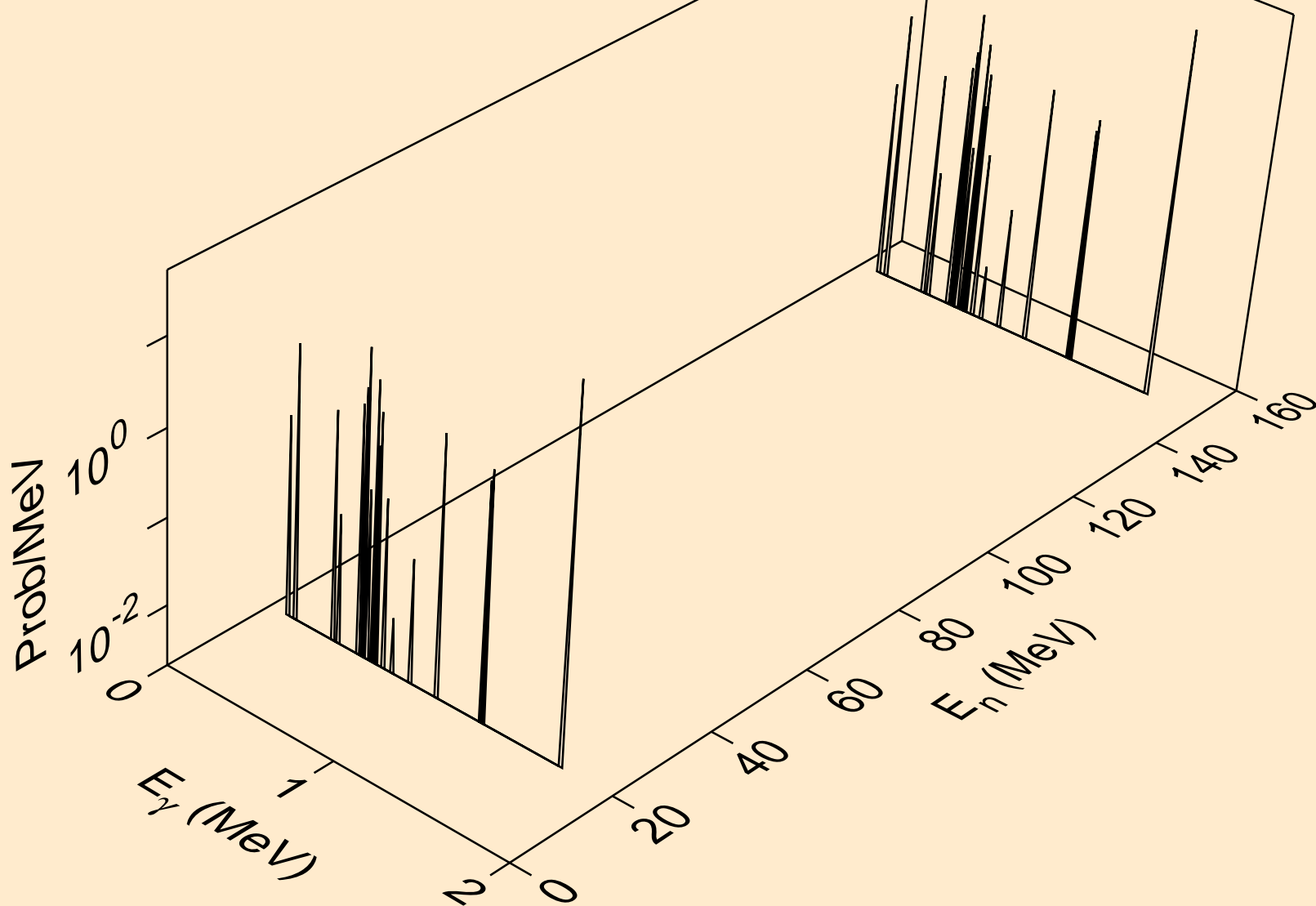

20-CA-42 FOR FENDL-3.1 FROM FENDL-3.1 WITH NJOY2012.50+  
Photon emission for (n,p\*28)

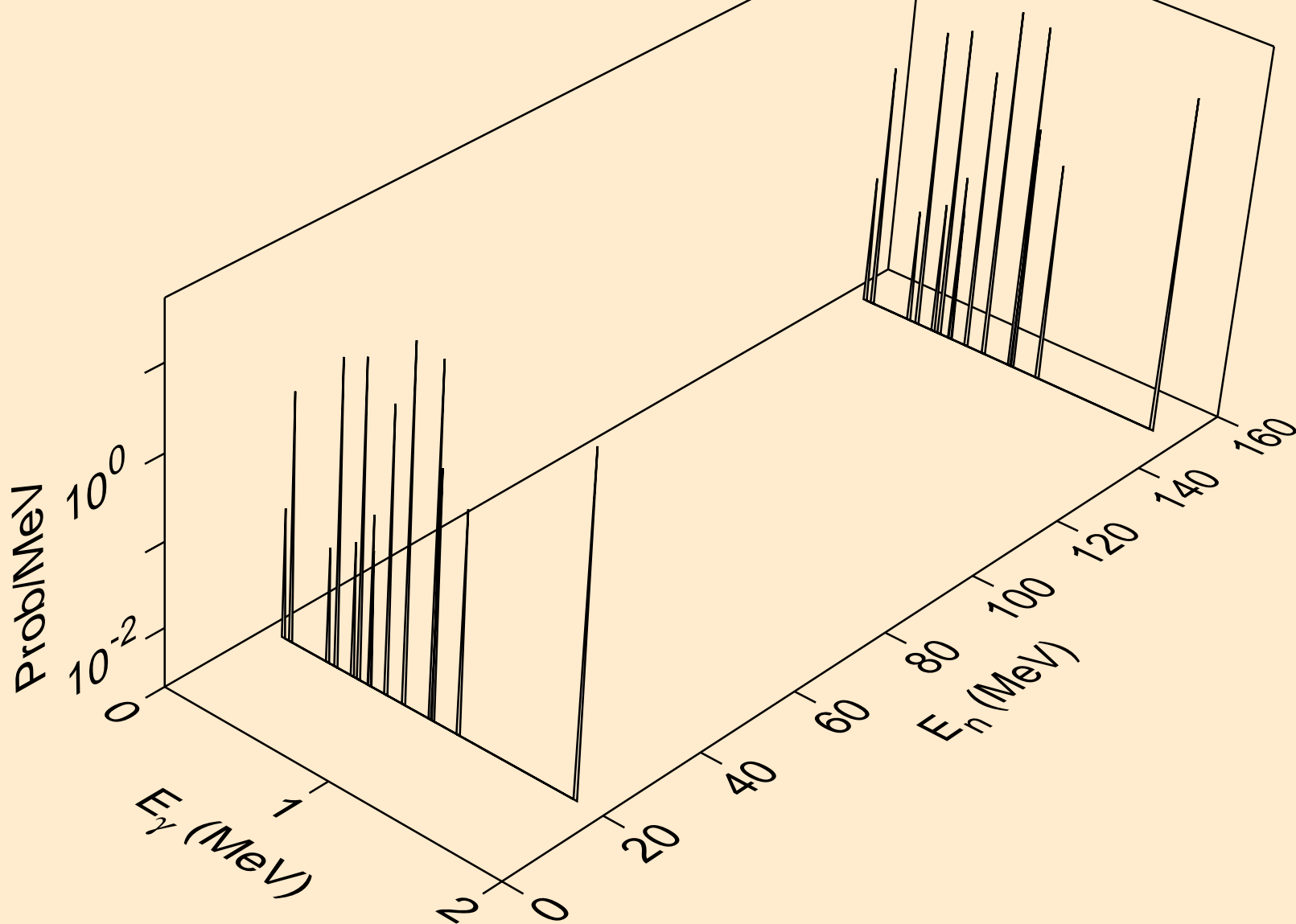



20-CA-42 FOR FENDL-3.1 FROM FENDL-3.1 WITH NJOY2012.50+  
Photon emission for (n,p\*29)

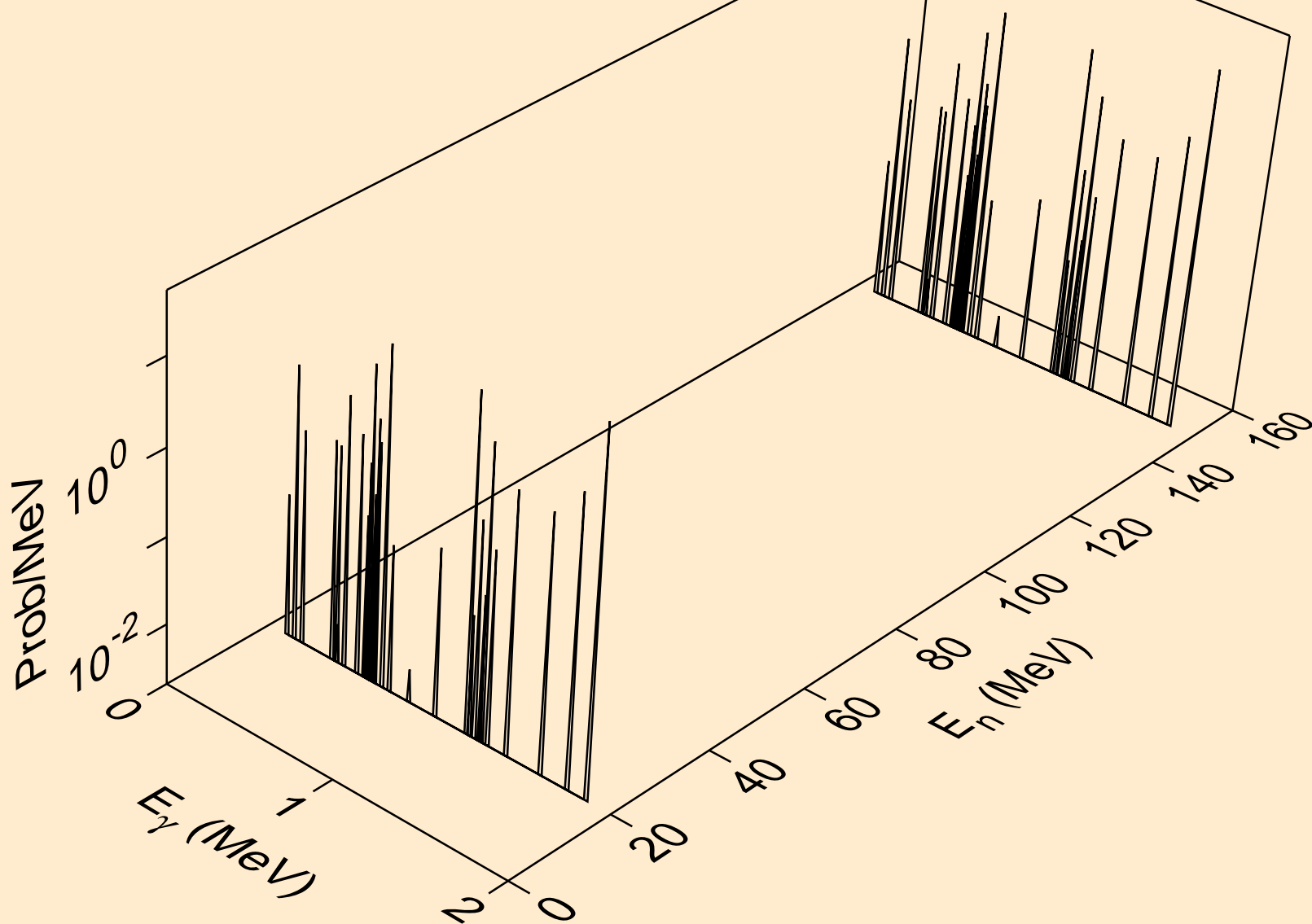

20-CA-42 FOR FENDL-3.1 FROM FENDL-3.1 WITH NJOY2012.50+  
Photon emission for (n,p\*30)

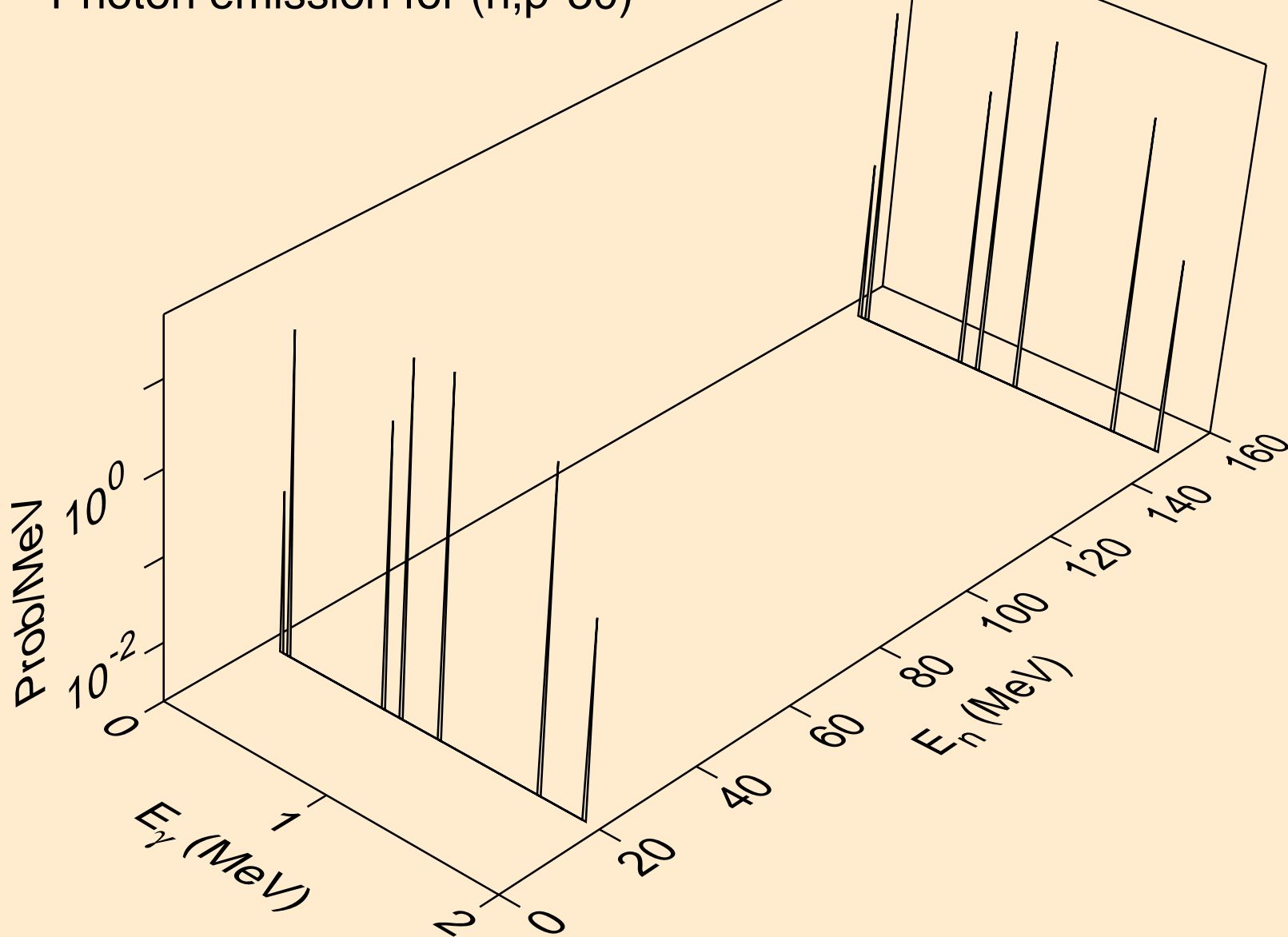

20-CA-42 FOR FENDL-3.1 FROM FENDL-3.1 WITH NJOY2012.50+  
Photon emission for (n,p\*31)

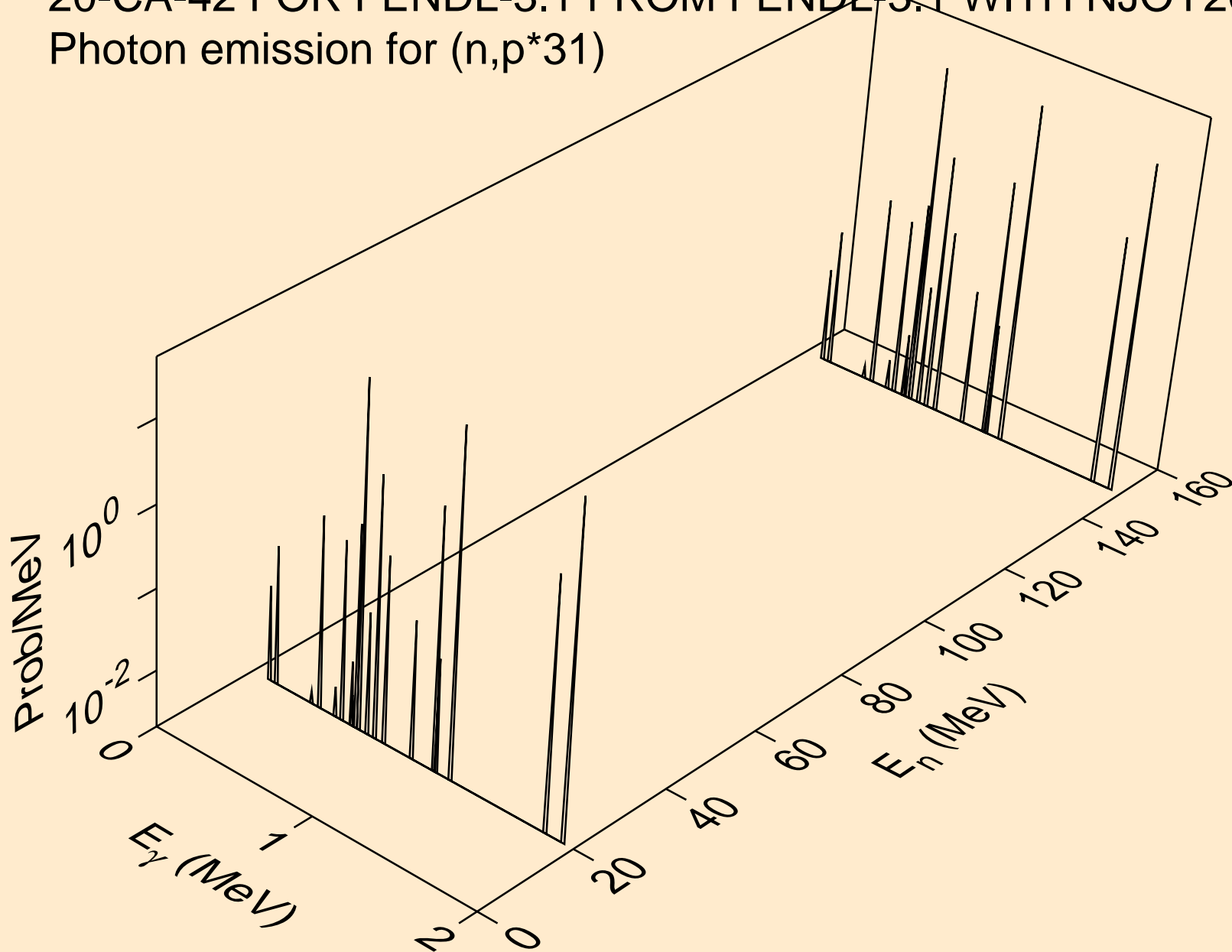

20-CA-42 FOR FENDL-3.1 FROM FENDL-3.1 WITH NJOY2012.50+  
Photon emission for (n,p\*32)

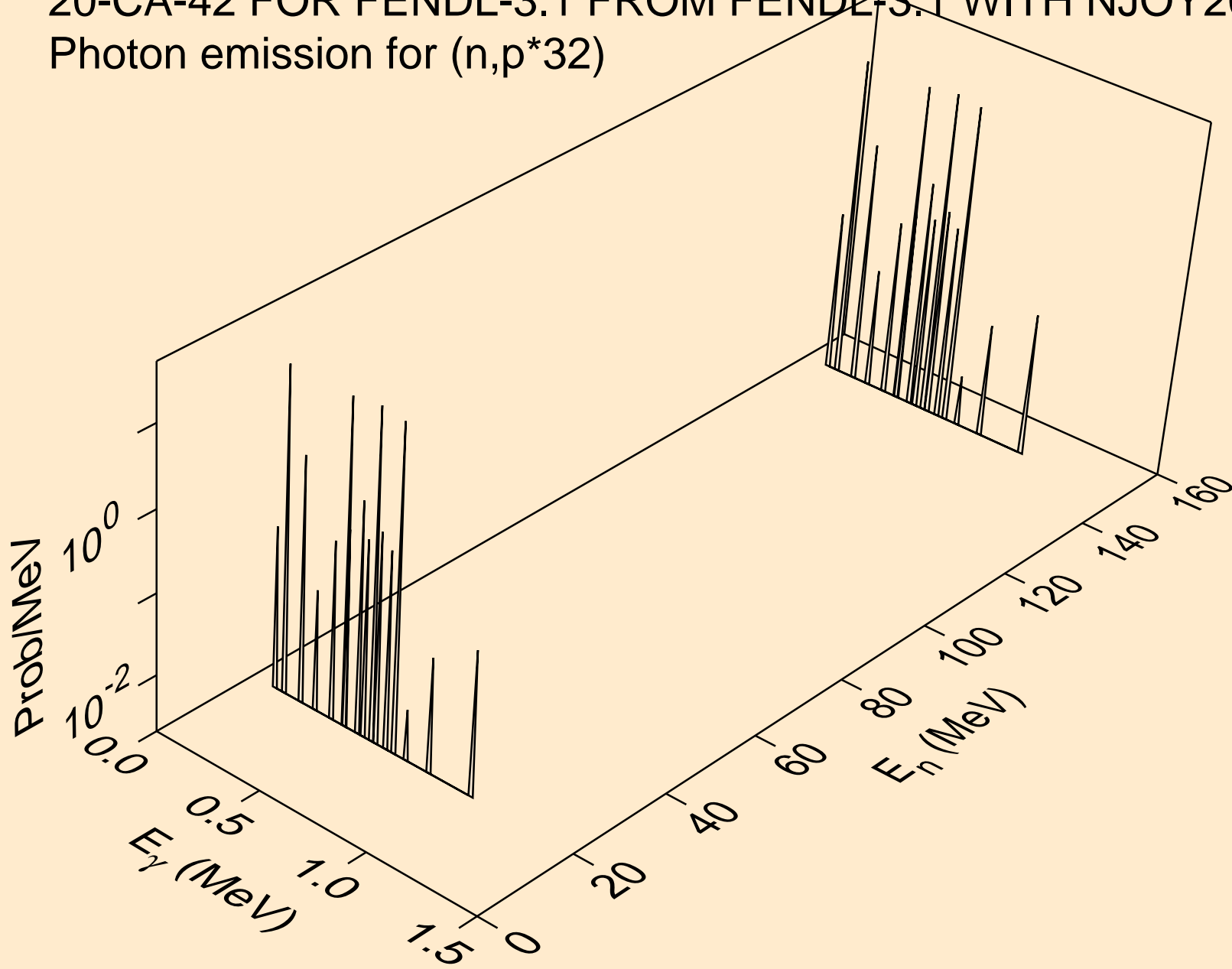

20-CA-42 FOR FENDL-3.1 FROM FENDL-3.1 WITH NJOY2012.50+  
Photon emission for (n,p\*33)

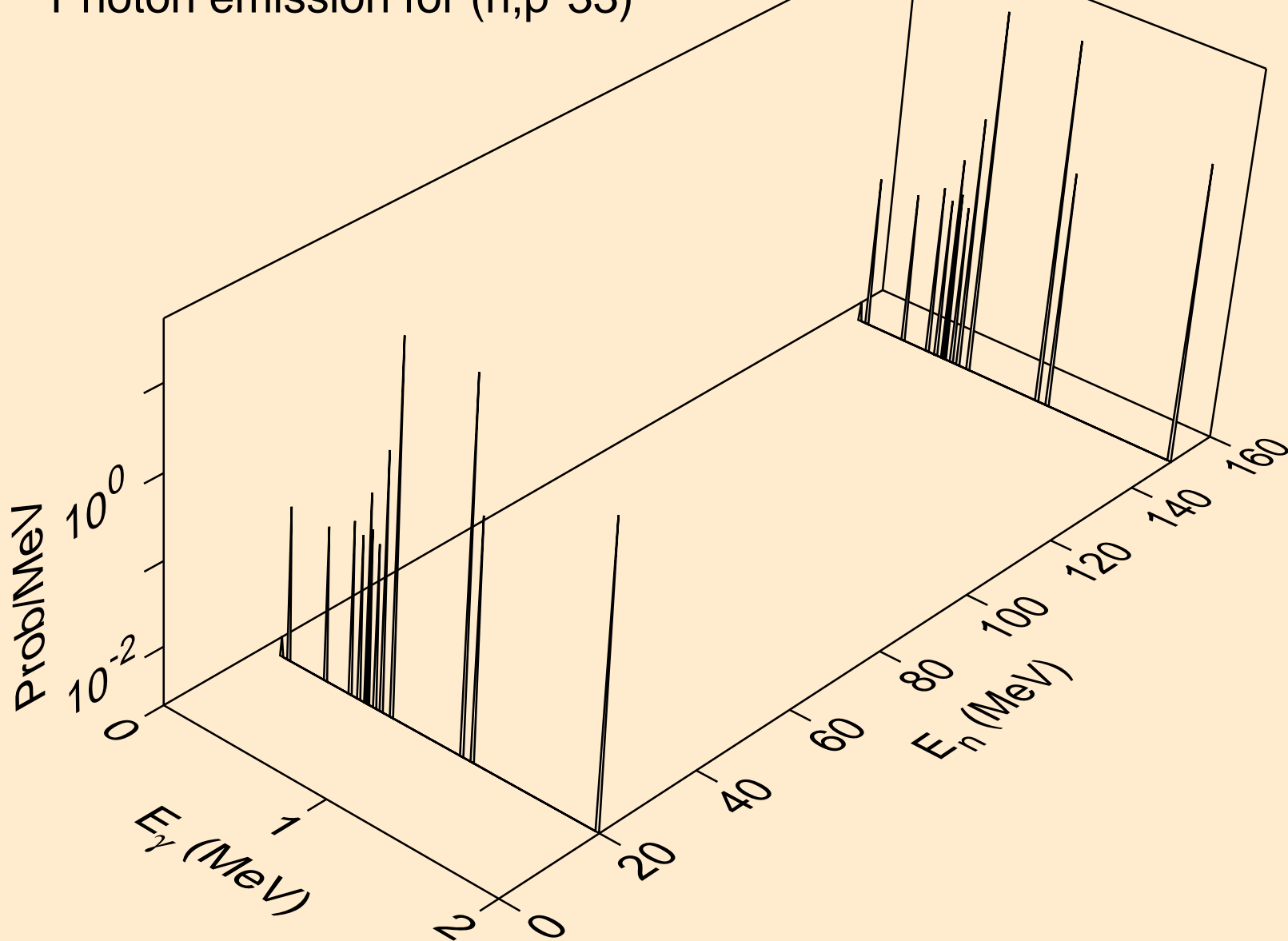

20-CA-42 FOR FENDL-3.1 FROM FENDL-3.1 WITH NJOY2012.50+  
Photon emission for (n,p\*34)

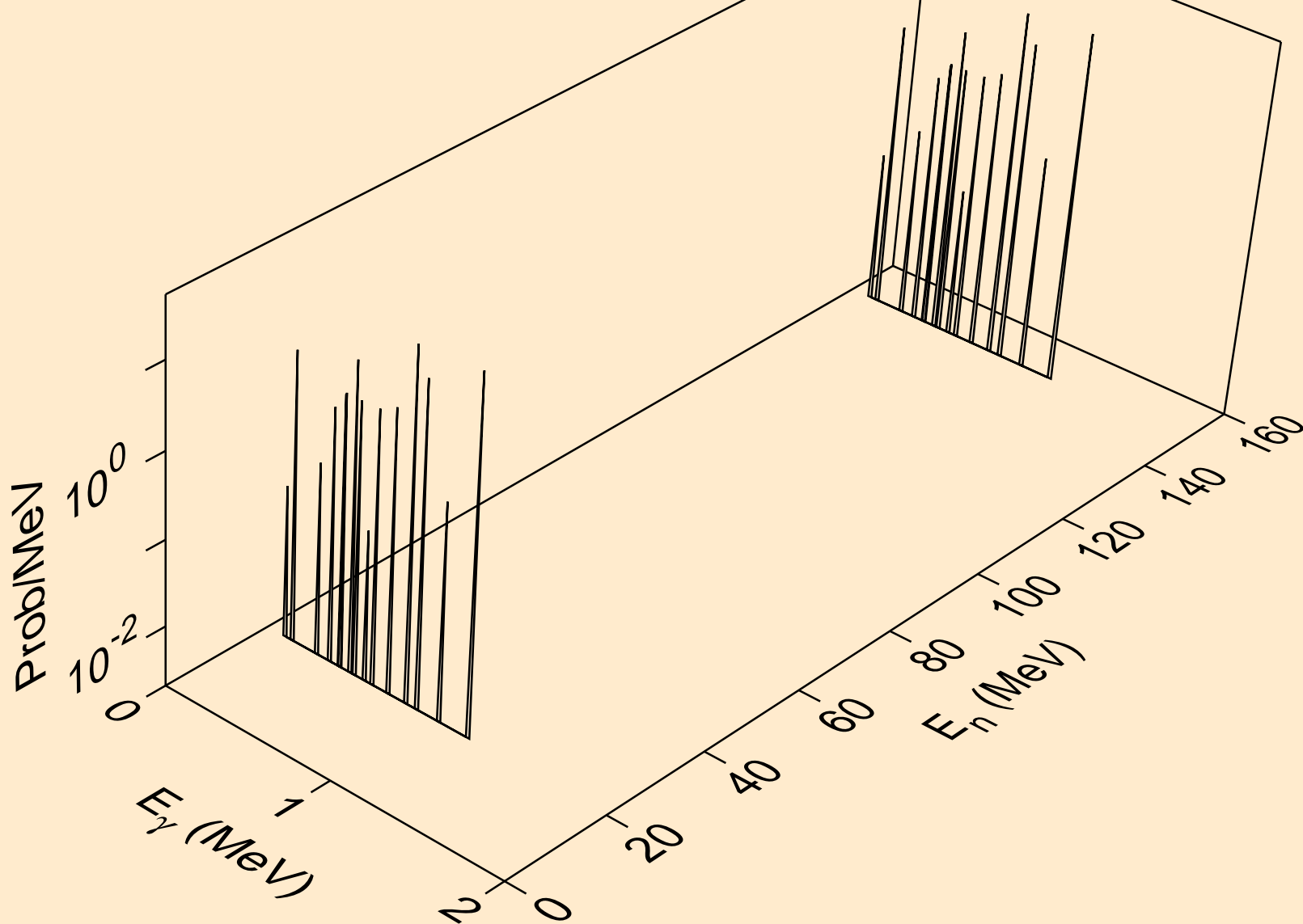

20-CA-42 FOR FENDL-3.1 FROM FENDL-3.1 WITH NJOY2012.50+  
Photon emission for (n,p\*35)

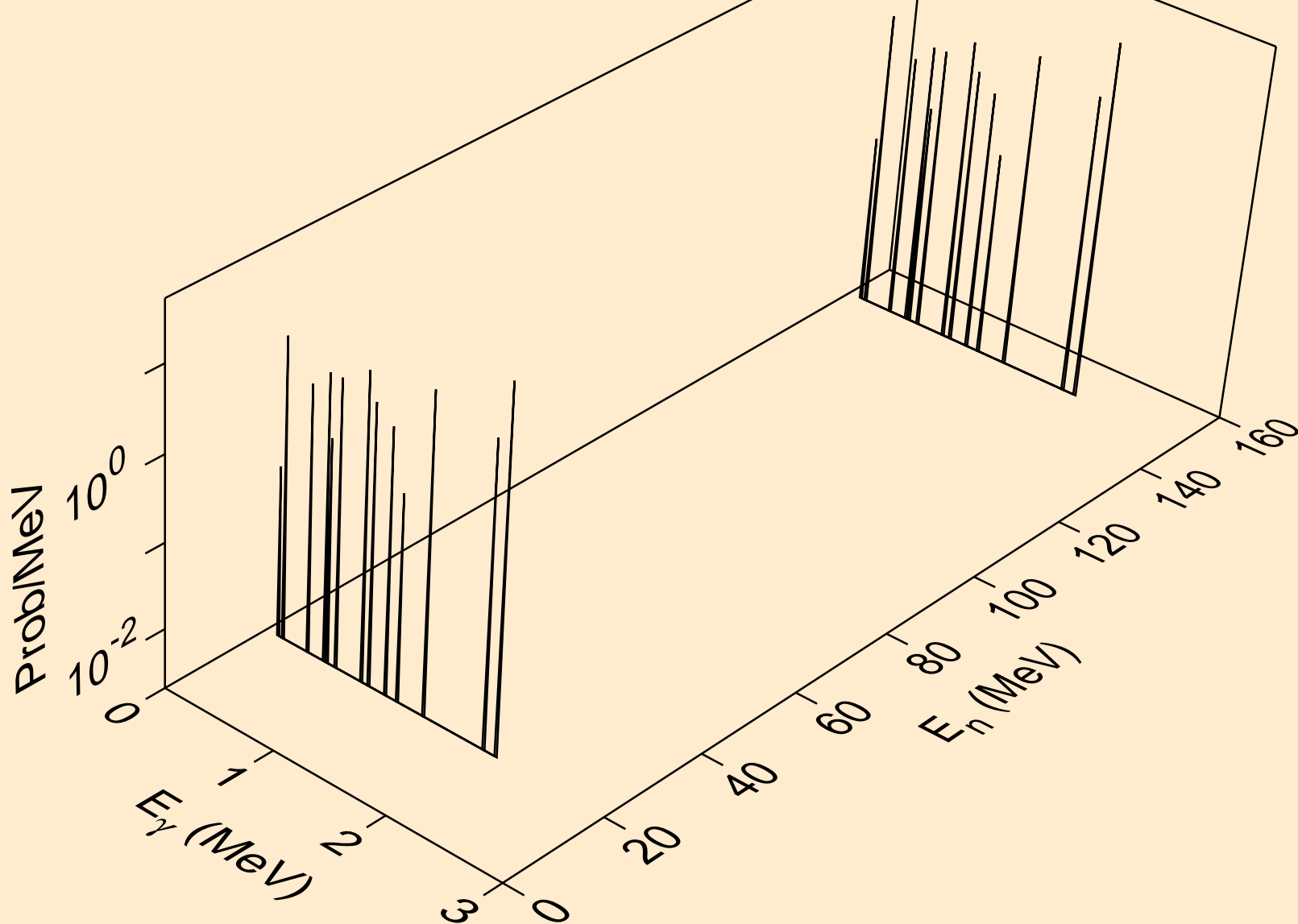

20-CA-42 FOR FENDL-3.1 FROM FENDL-3.1 WITH NJOY2012.50+  
Photon emission for (n,p\*36)

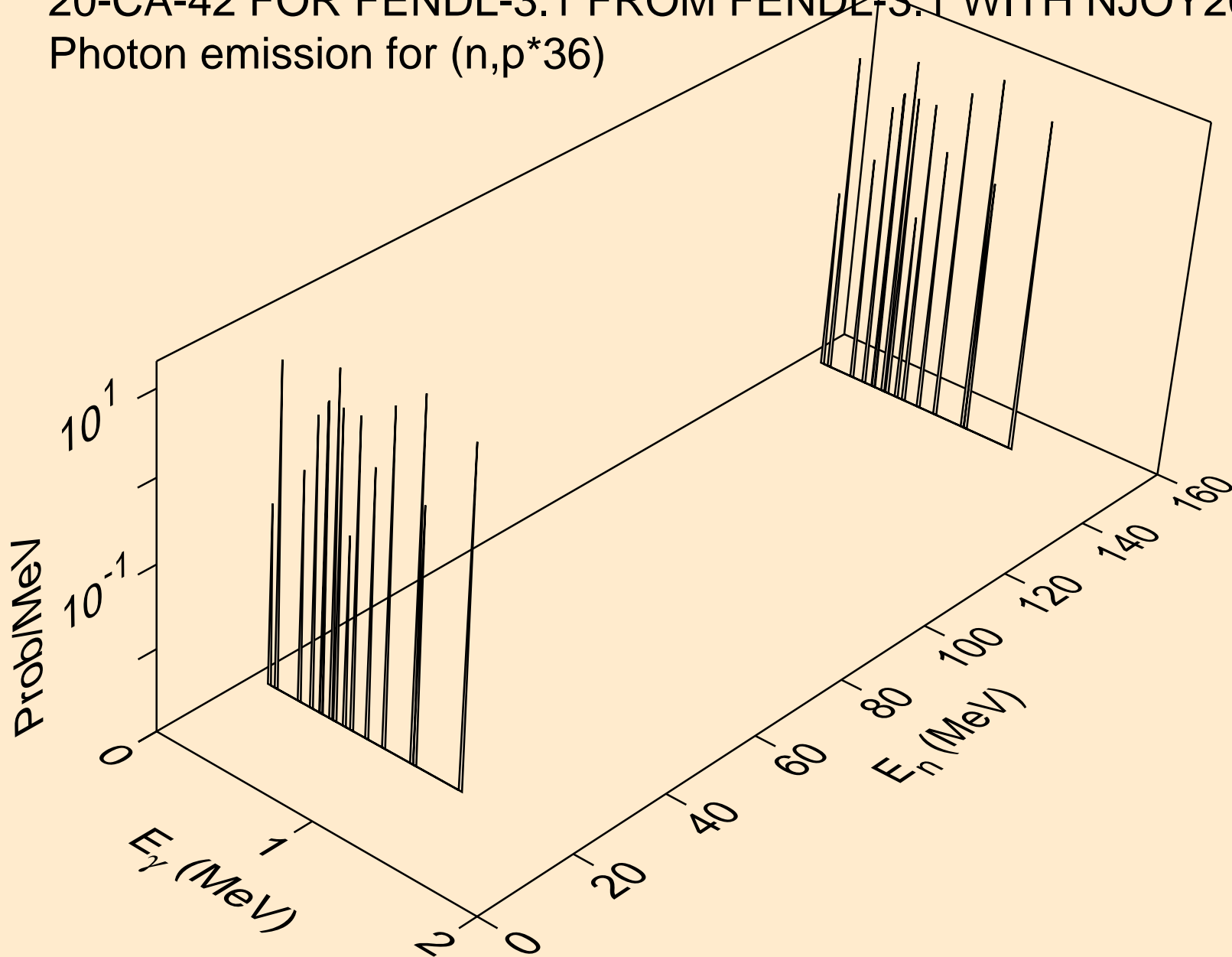



20-CA-42 FOR FENDL-3.1 FROM FENDL-3.1 WITH NJOY2012.50+  
Photon emission for (n,p\*37)

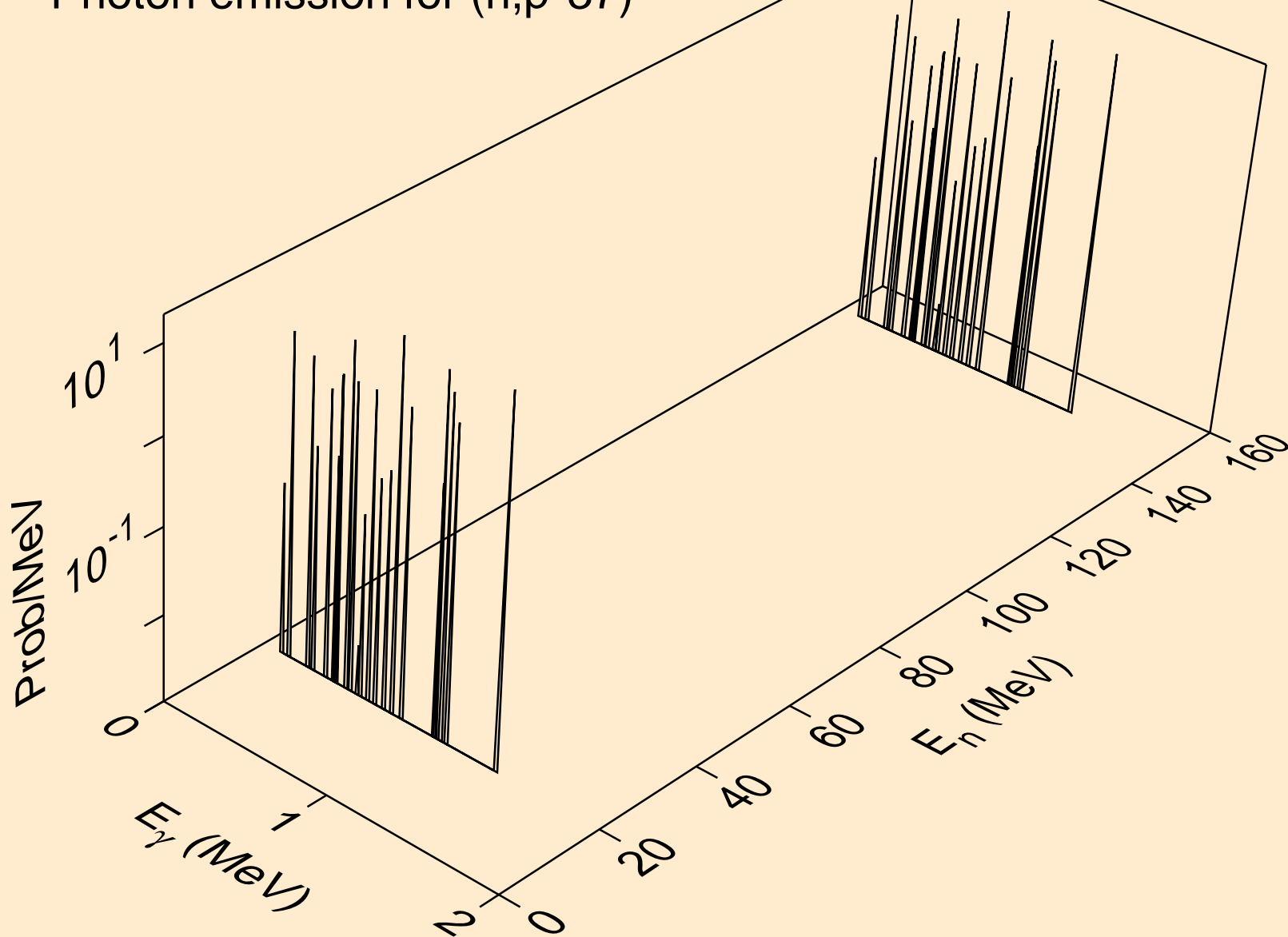

20-CA-42 FOR FENDL-3.1 FROM FENDL-3.1 WITH NJOY2012.50+  
Photon emission for (n,p\*38)

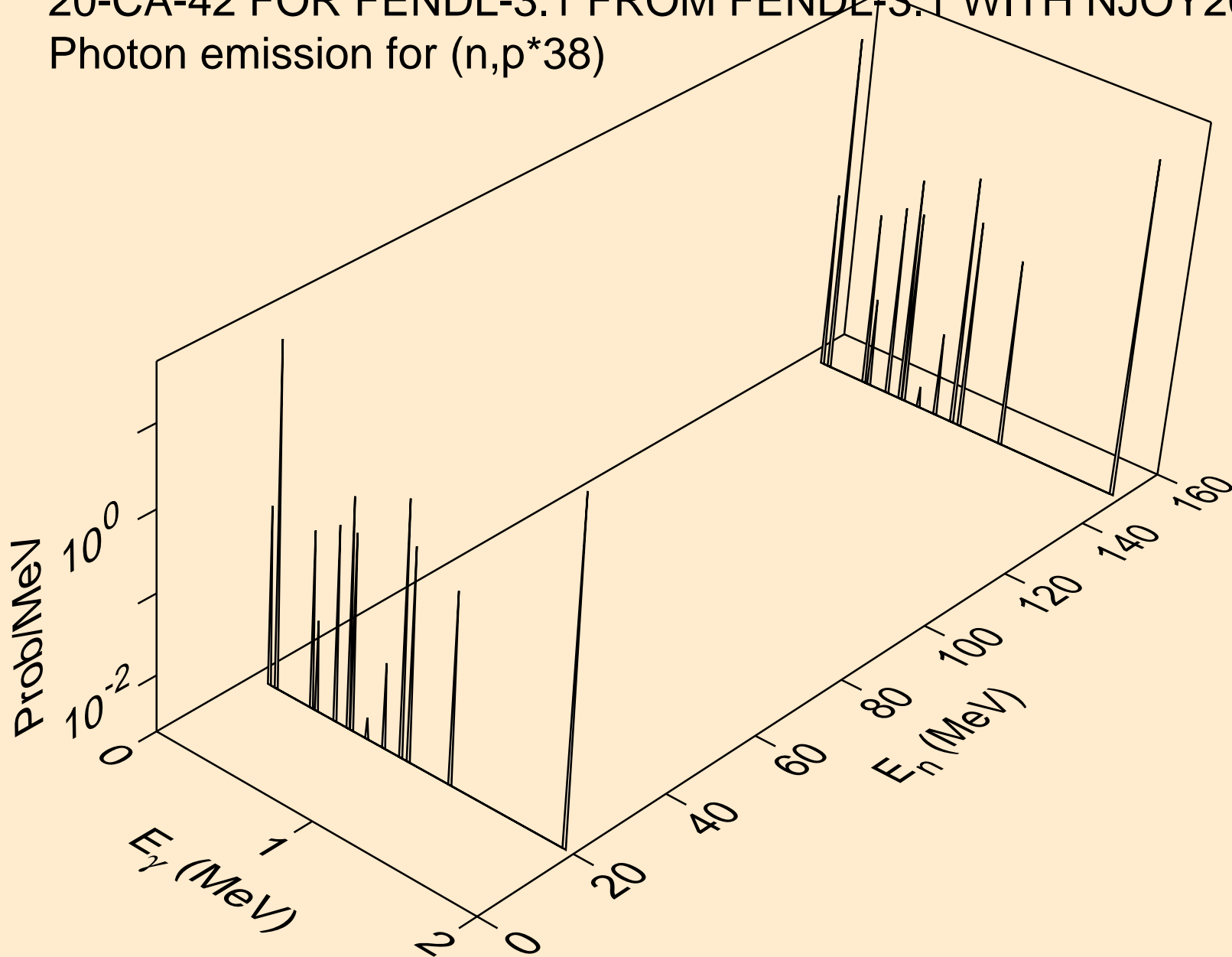

20-CA-42 FOR FENDL-3.1 FROM FENDL-3.1 WITH NJOY2012.50+  
Photon emission for (n,p\*39)

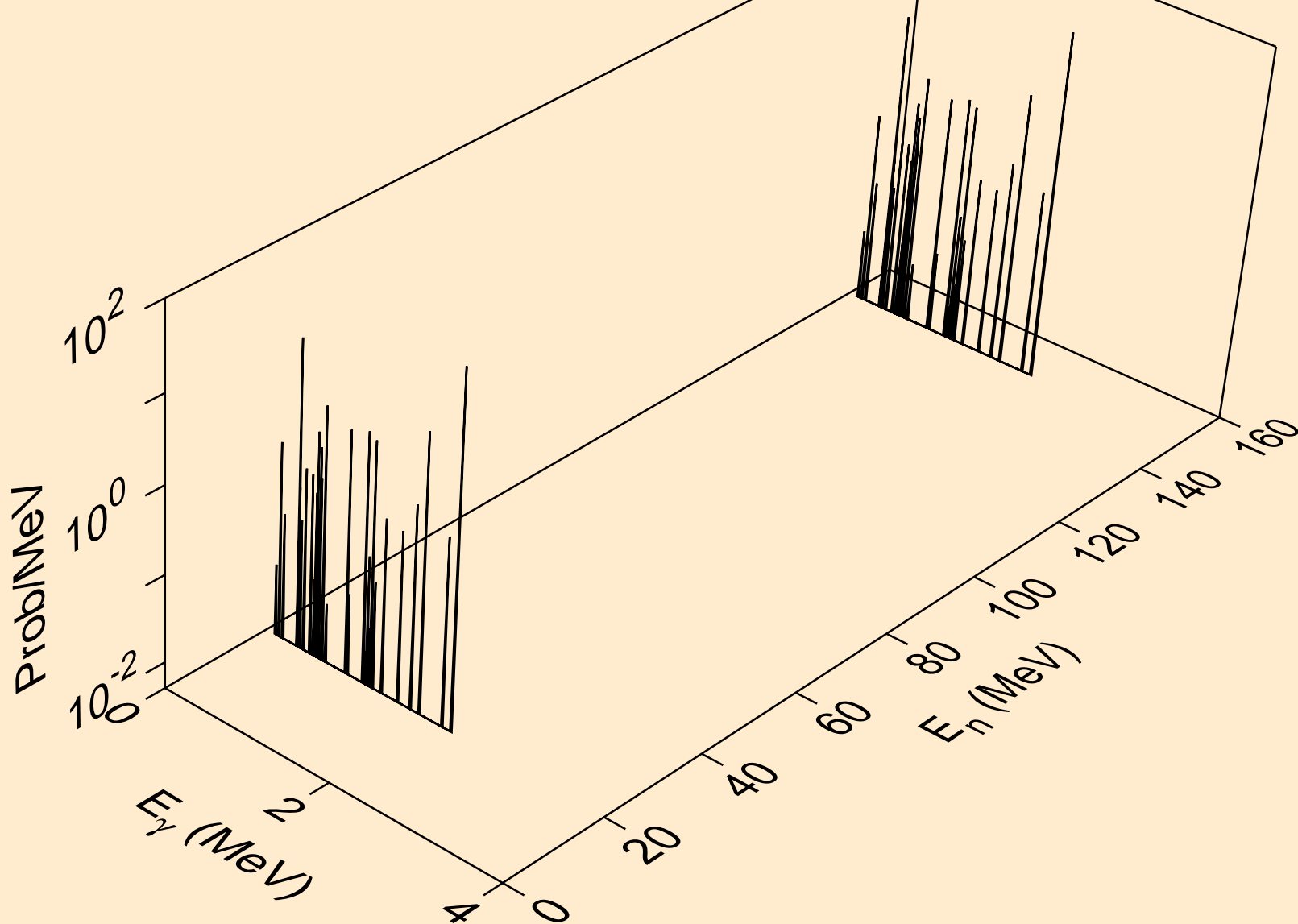

20-CA-42 FOR FENDL-3.1 FROM FENDL-3.1 WITH NJOY2012.50+  
Photon emission for (n,p\*c)

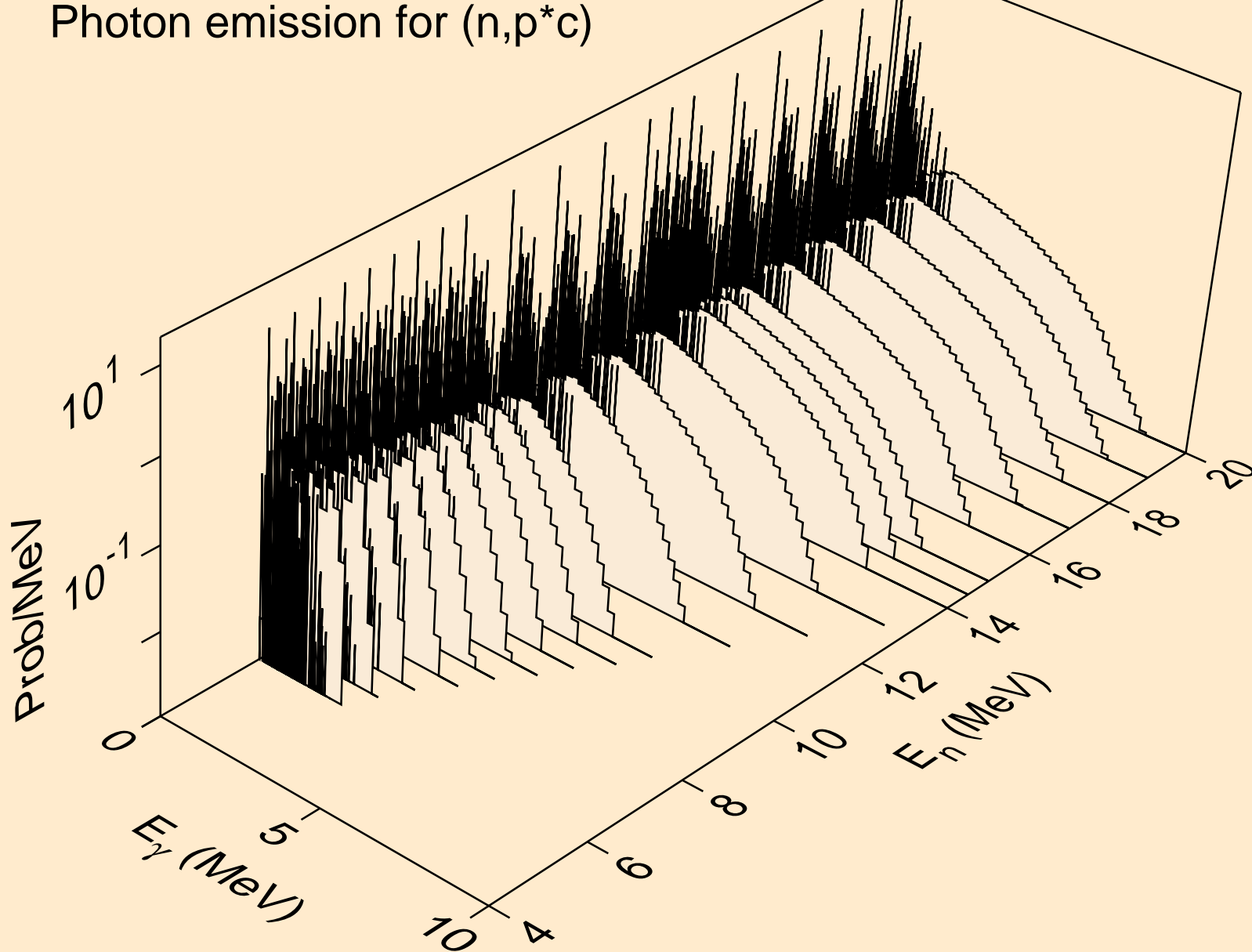

20-CA-42 FOR FENDL-3.1 FROM FENDL-3.1 WITH NJOY2012.50+  
Photon emission for (n,a\*1)

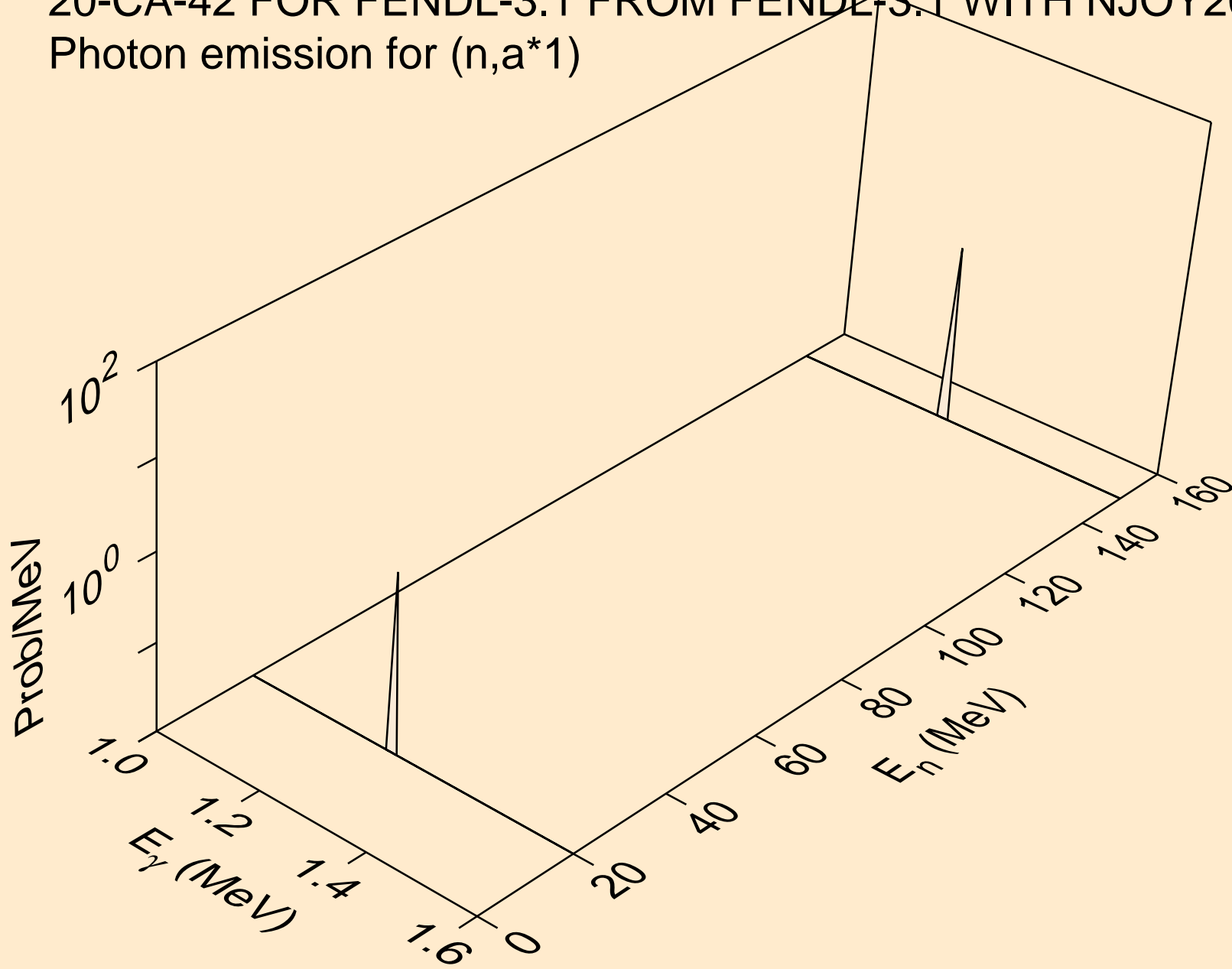

20-CA-42 FOR FENDL-3.1 FROM FENDL-3.1 WITH NJOY2012.50+  
Photon emission for (n,a\*2)

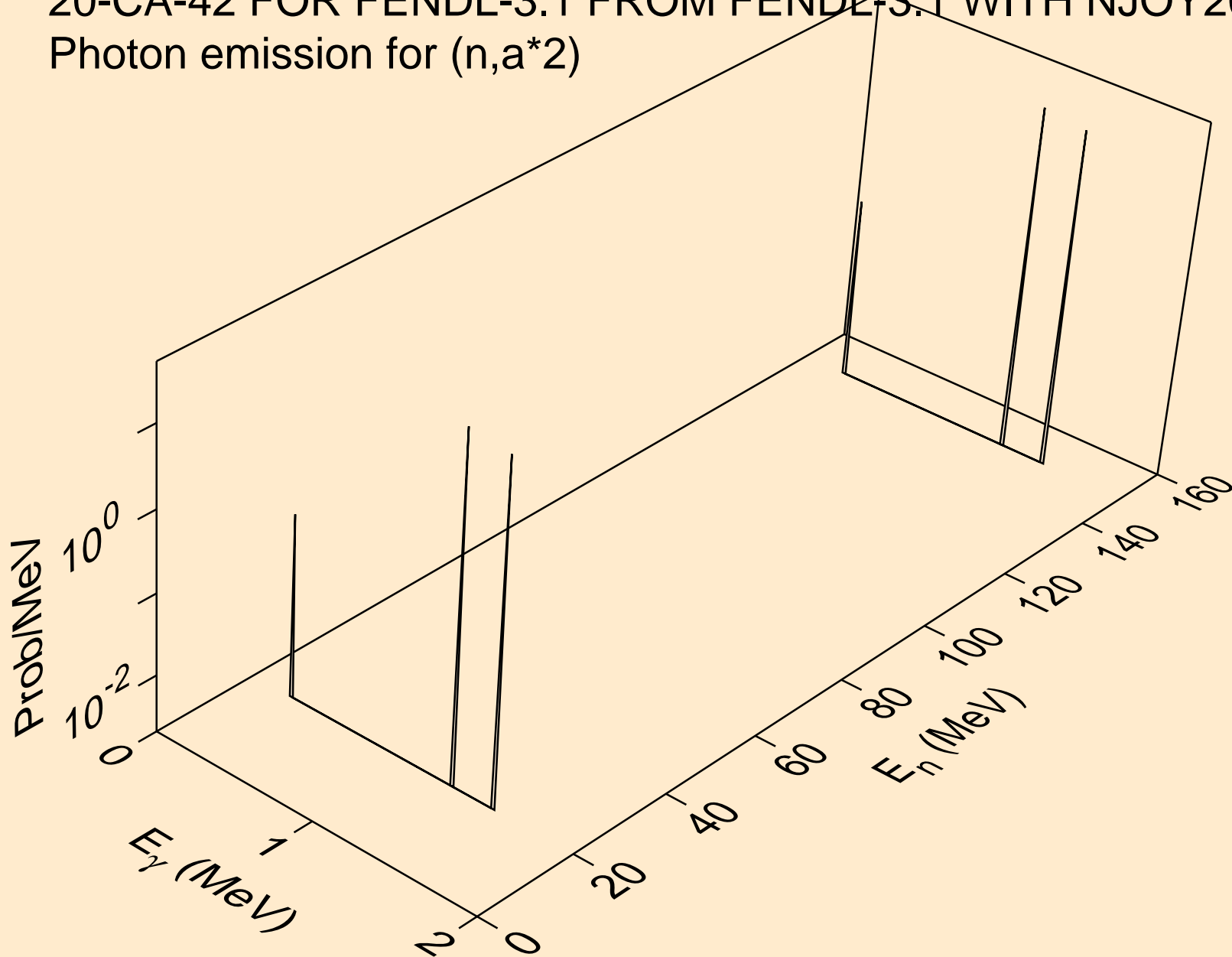

20-CA-42 FOR FENDL-3.1 FROM FENDL-3.1 WITH NJOY2012.50+  
Photon emission for (n,a\*3)

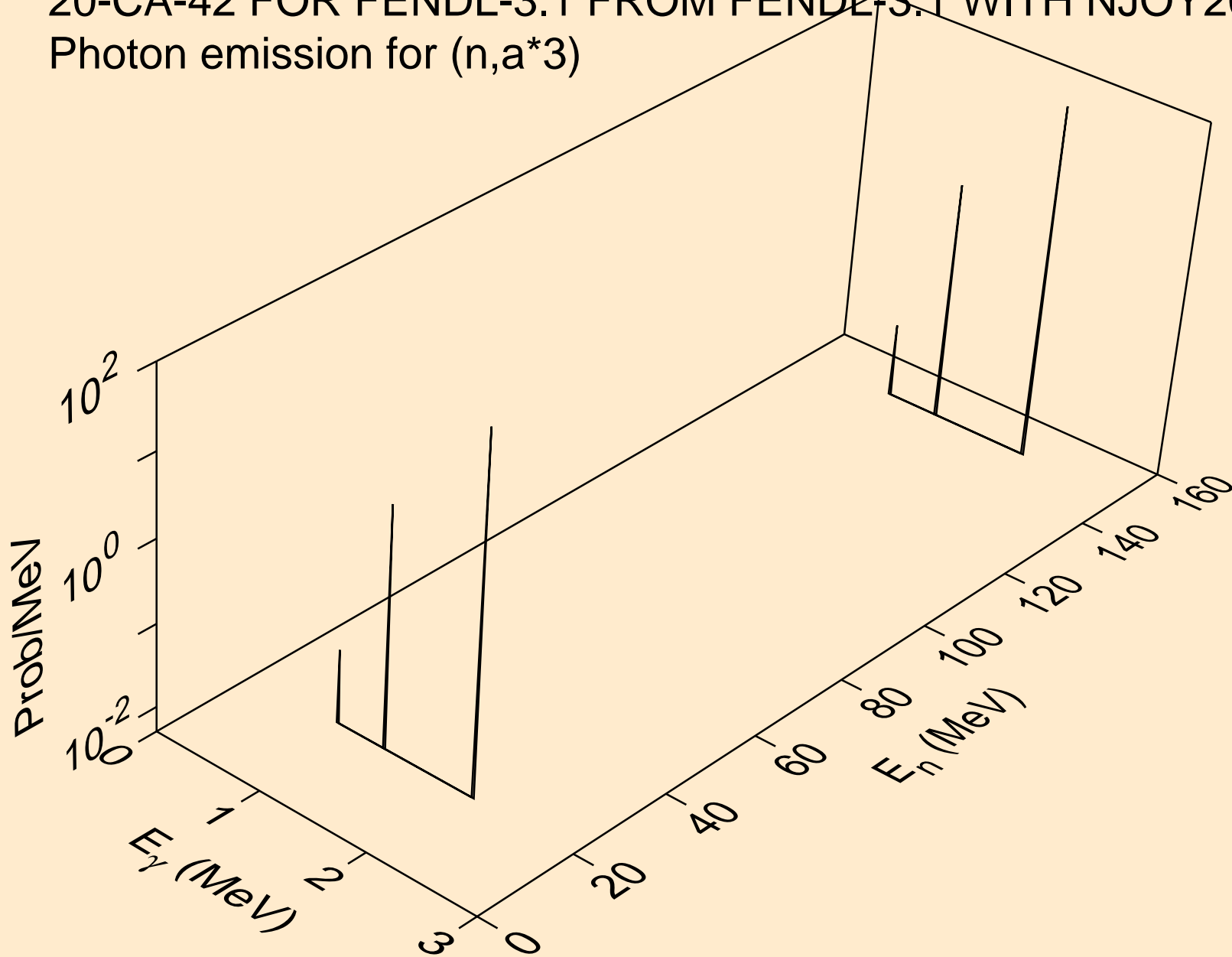

20-CA-42 FOR FENDL-3.1 FROM FENDL-3.1 WITH NJOY2012.50+  
Photon emission for (n,a\*4)

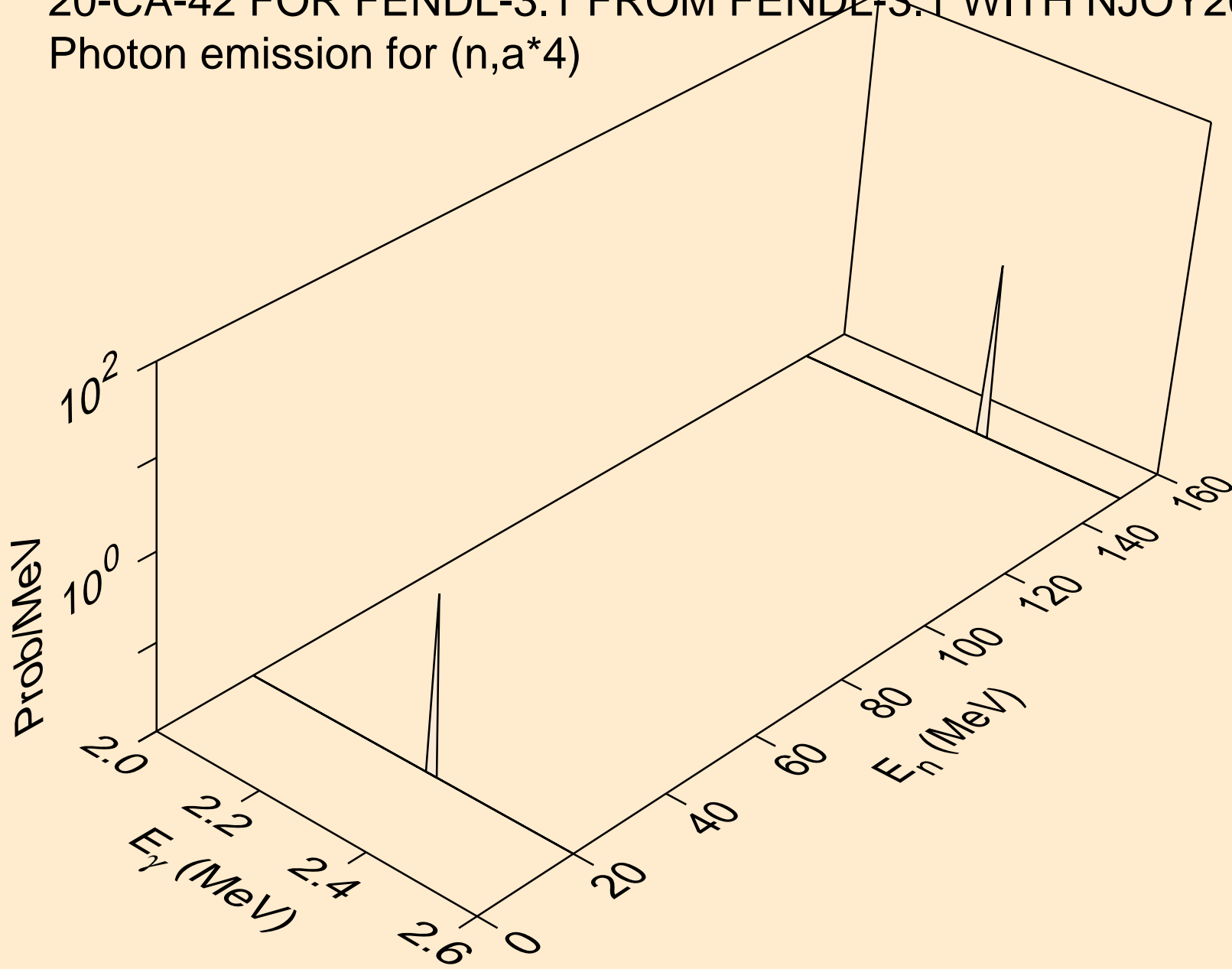



20-CA-42 FOR FENDL-3.1 FROM FENDL-3.1 WITH NJOY2012.50+  
Photon emission for (n,a\*5)

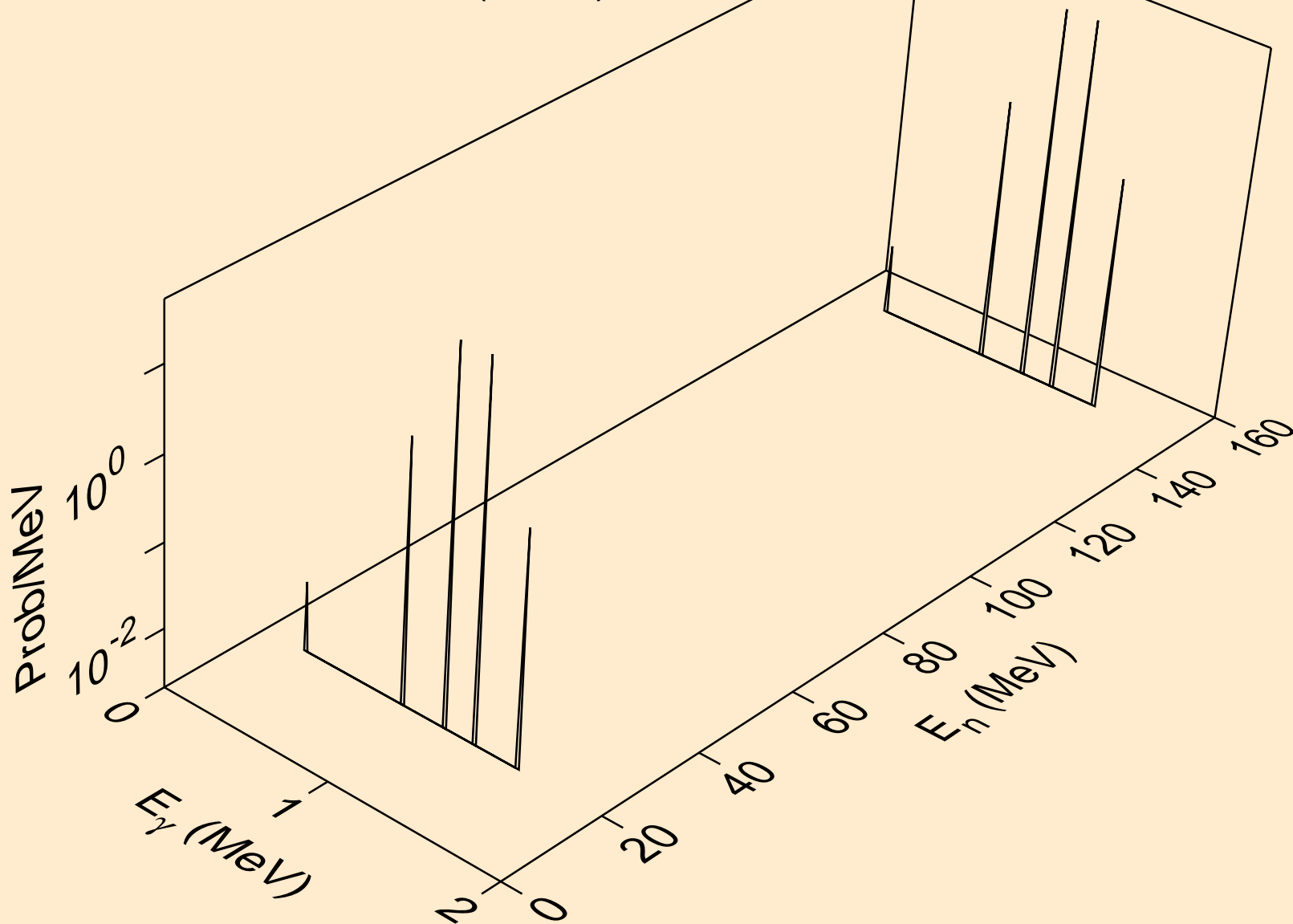

20-CA-42 FOR FENDL-3.1 FROM FENDL-3.1 WITH NJOY2012.50+  
Photon emission for (n,a\*6)

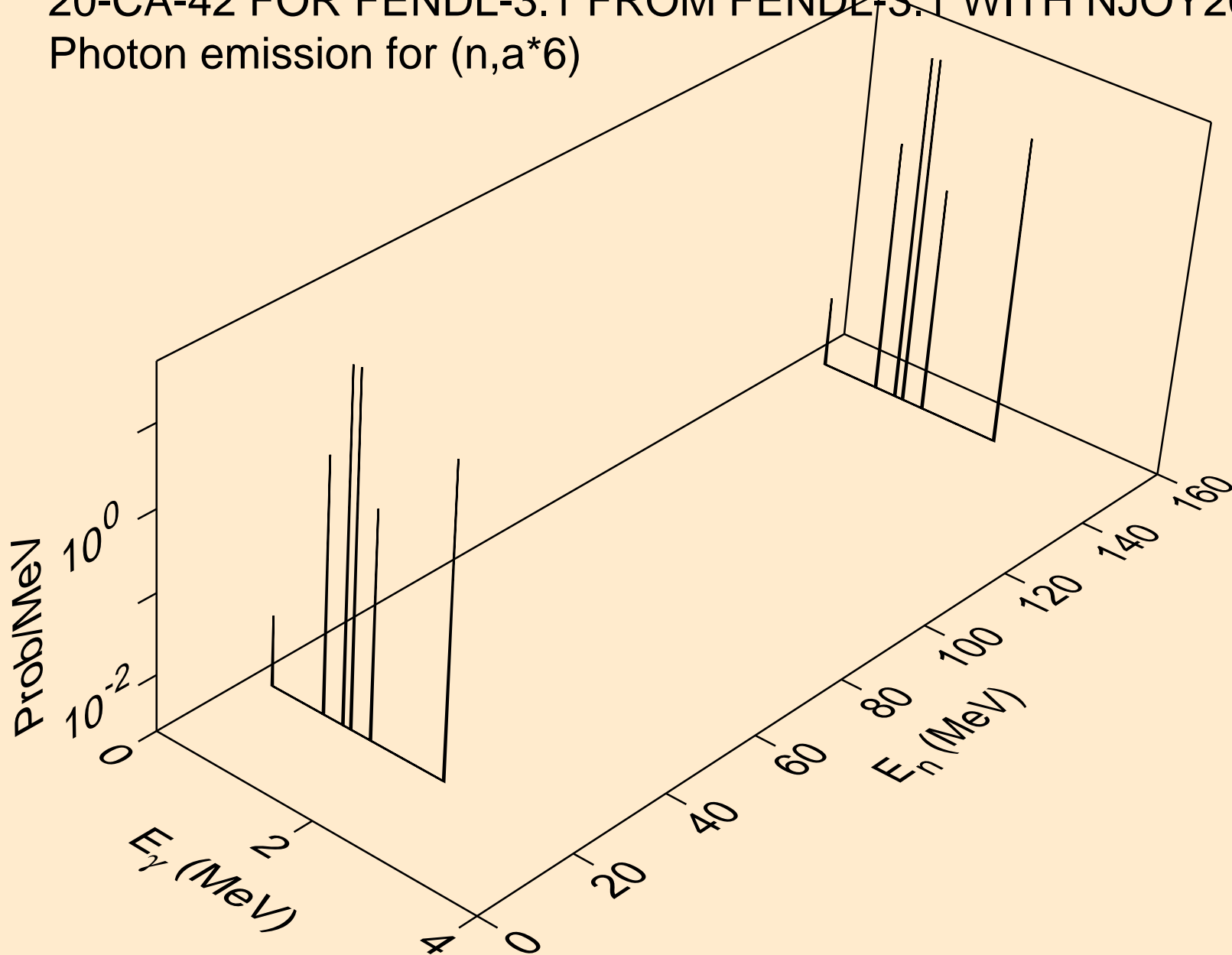

20-CA-42 FOR FENDL-3.1 FROM FENDL-3.1 WITH NJOY2012.50+  
Photon emission for (n,a\*7)

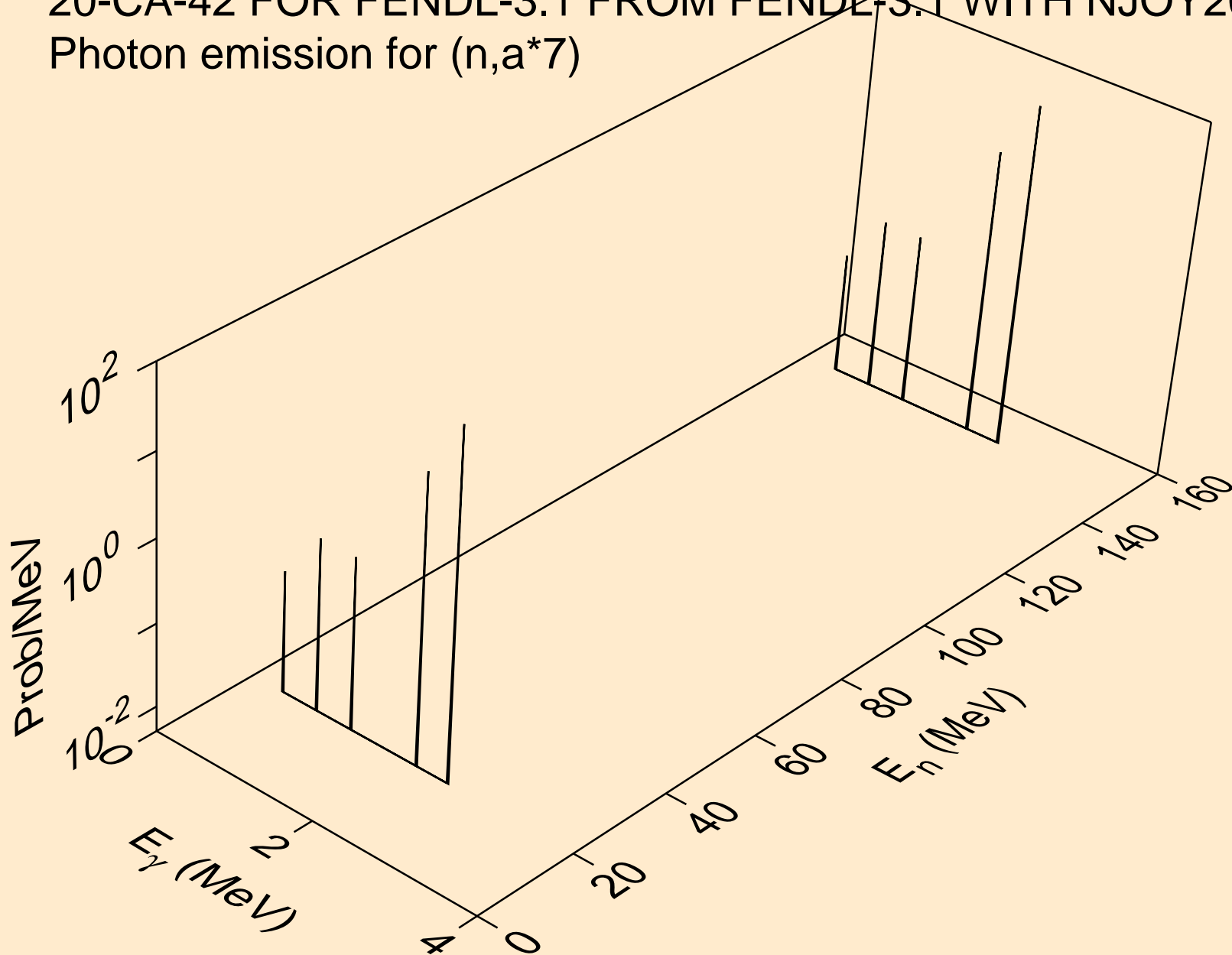

20-CA-42 FOR FENDL-3.1 FROM FENDL-3.1 WITH NJOY2012.50+  
Photon emission for (n,a\*8)

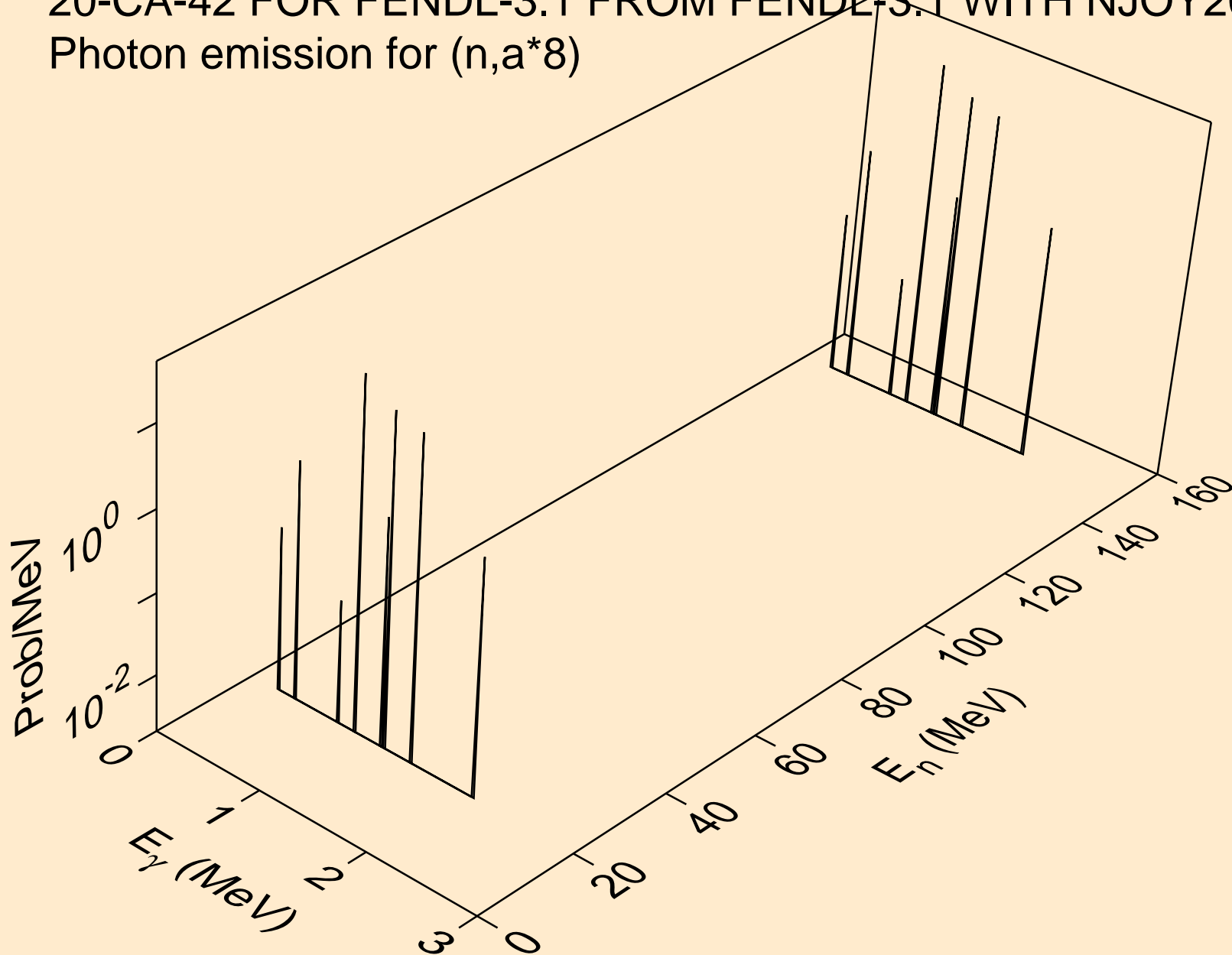

20-CA-42 FOR FENDL-3.1 FROM FENDL-3.1 WITH NJOY2012.50+  
Photon emission for (n,a\*9)

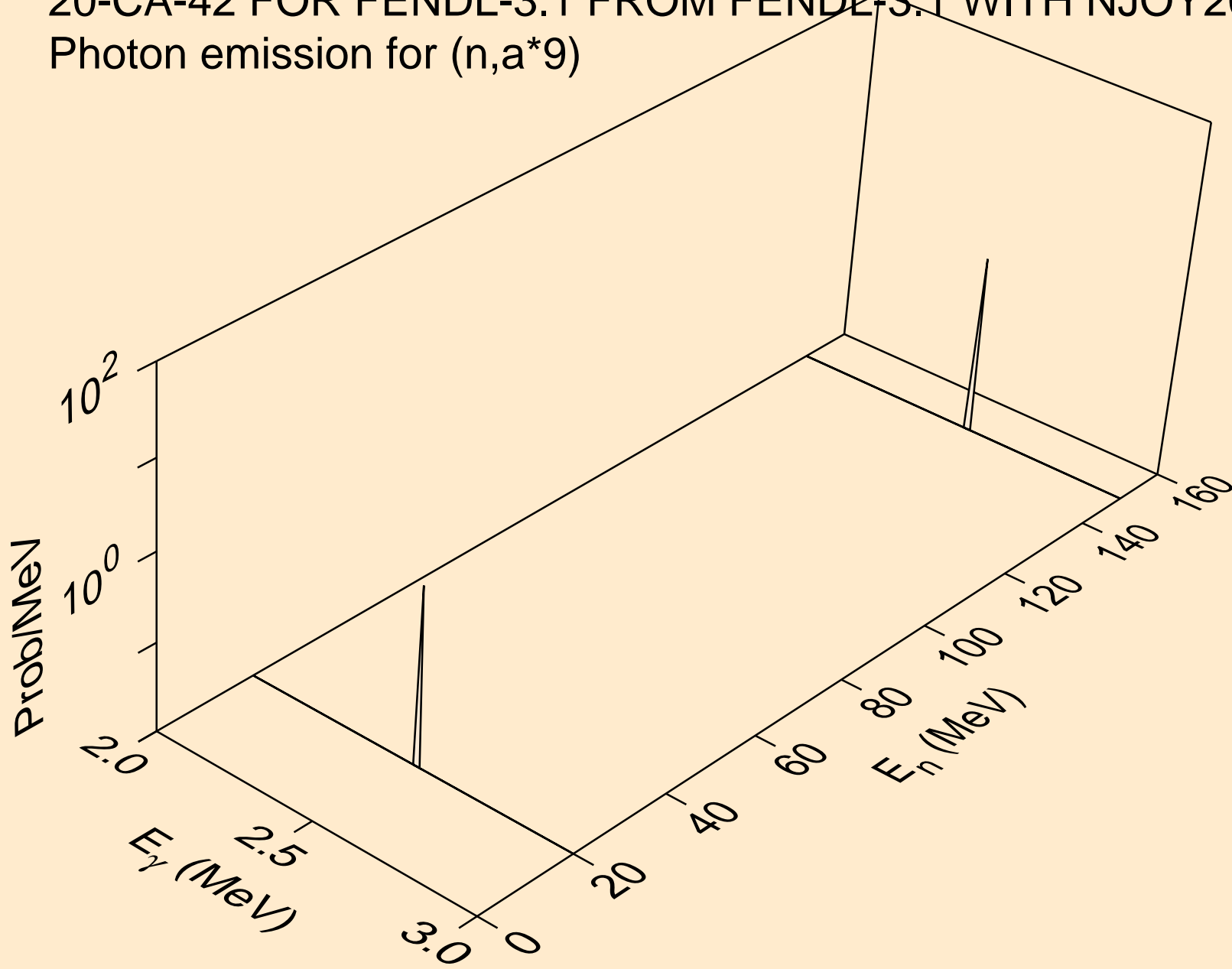

20-CA-42 FOR FENDL-3.1 FROM FENDL-3.1 WITH NJOY2012.50+  
Photon emission for (n,a\*10)

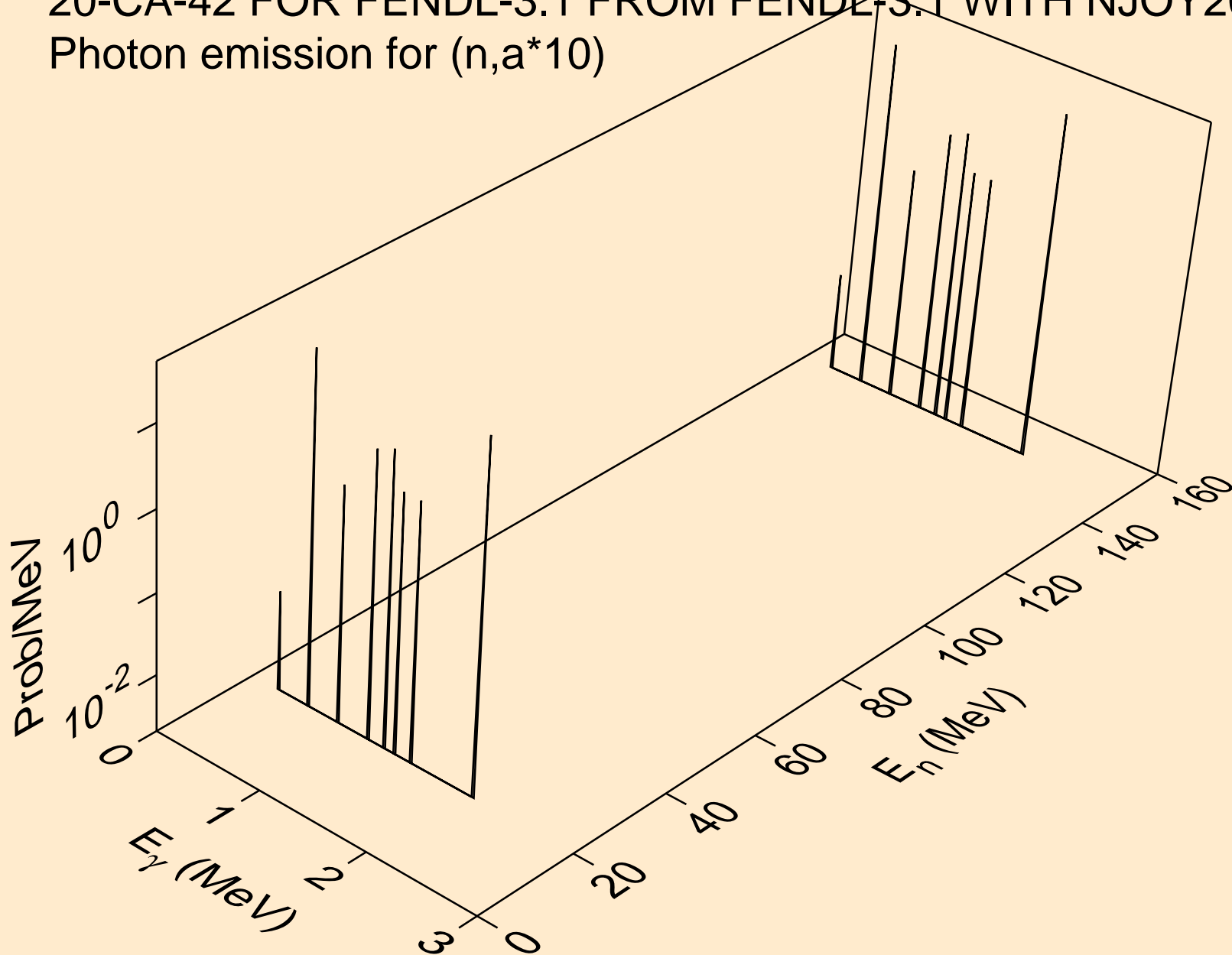

20-CA-42 FOR FENDL-3.1 FROM FENDL-3.1 WITH NJOY2012.50+  
Photon emission for (n,a\*11)

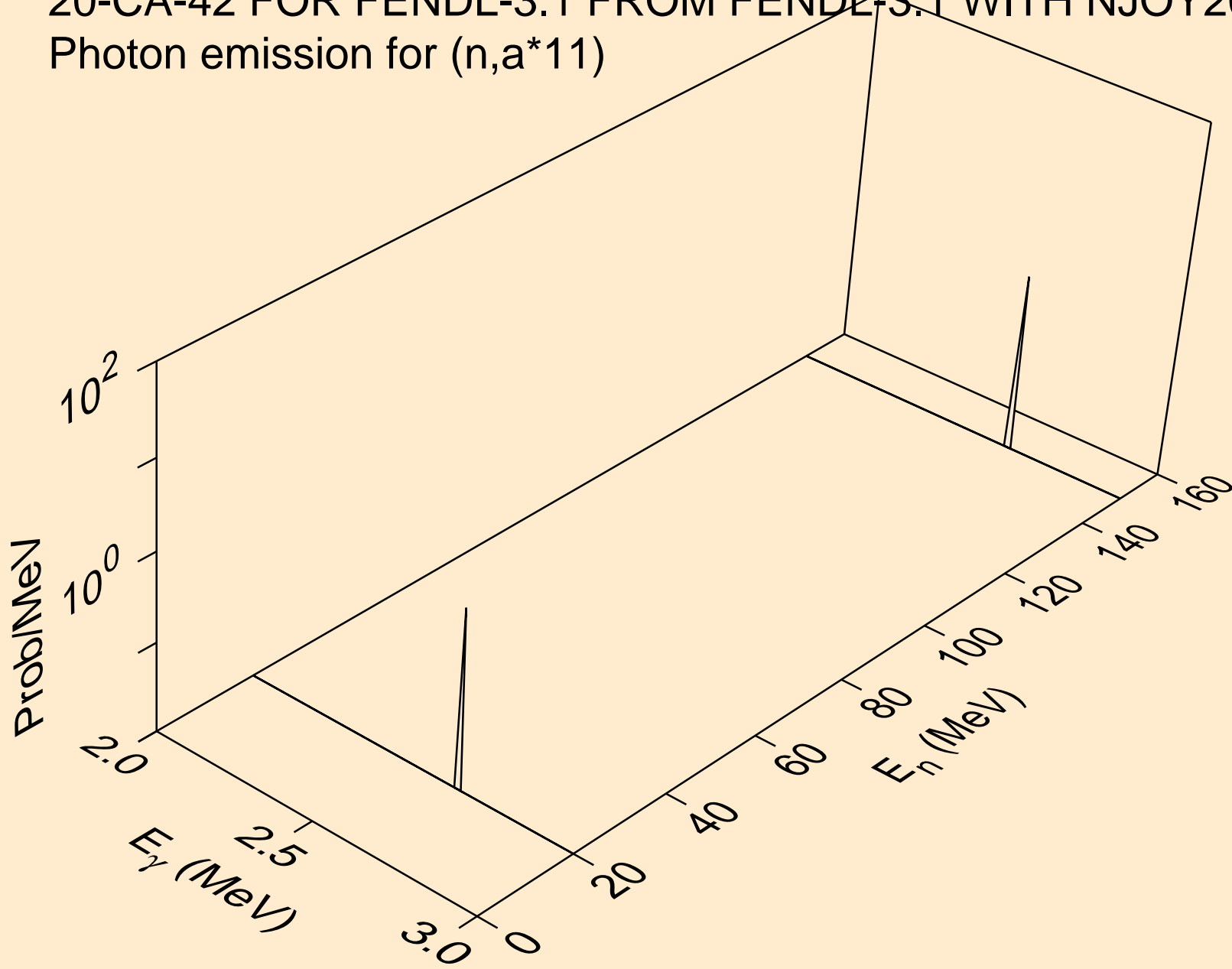

20-CA-42 FOR FENDL-3.1 FROM FENDL-3.1 WITH NJOY2012.50+  
Photon emission for (n,a\*12)

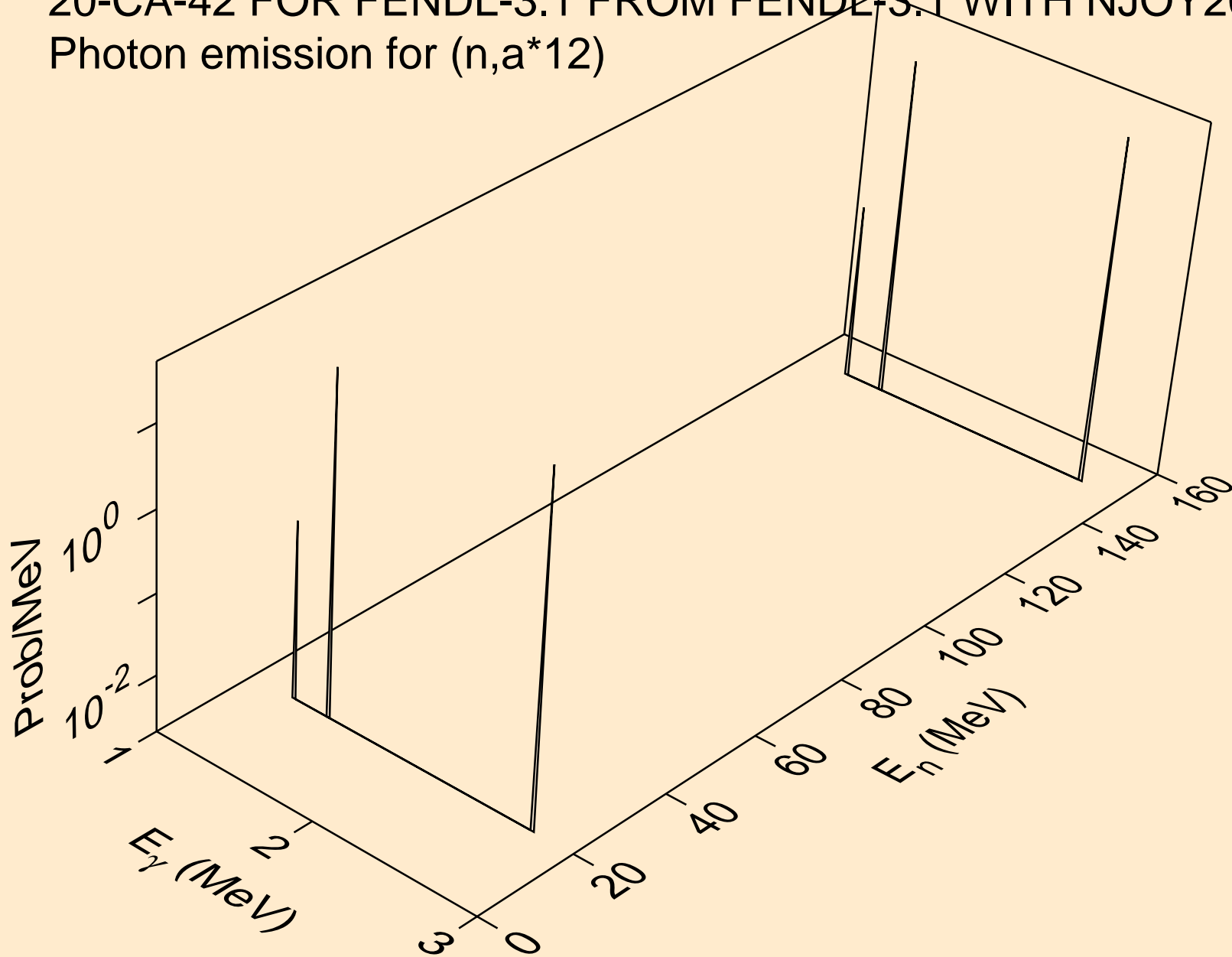



20-CA-42 FOR FENDL-3.1 FROM FENDL-3.1 WITH NJOY2012.50+  
Photon emission for (n,a\*13)

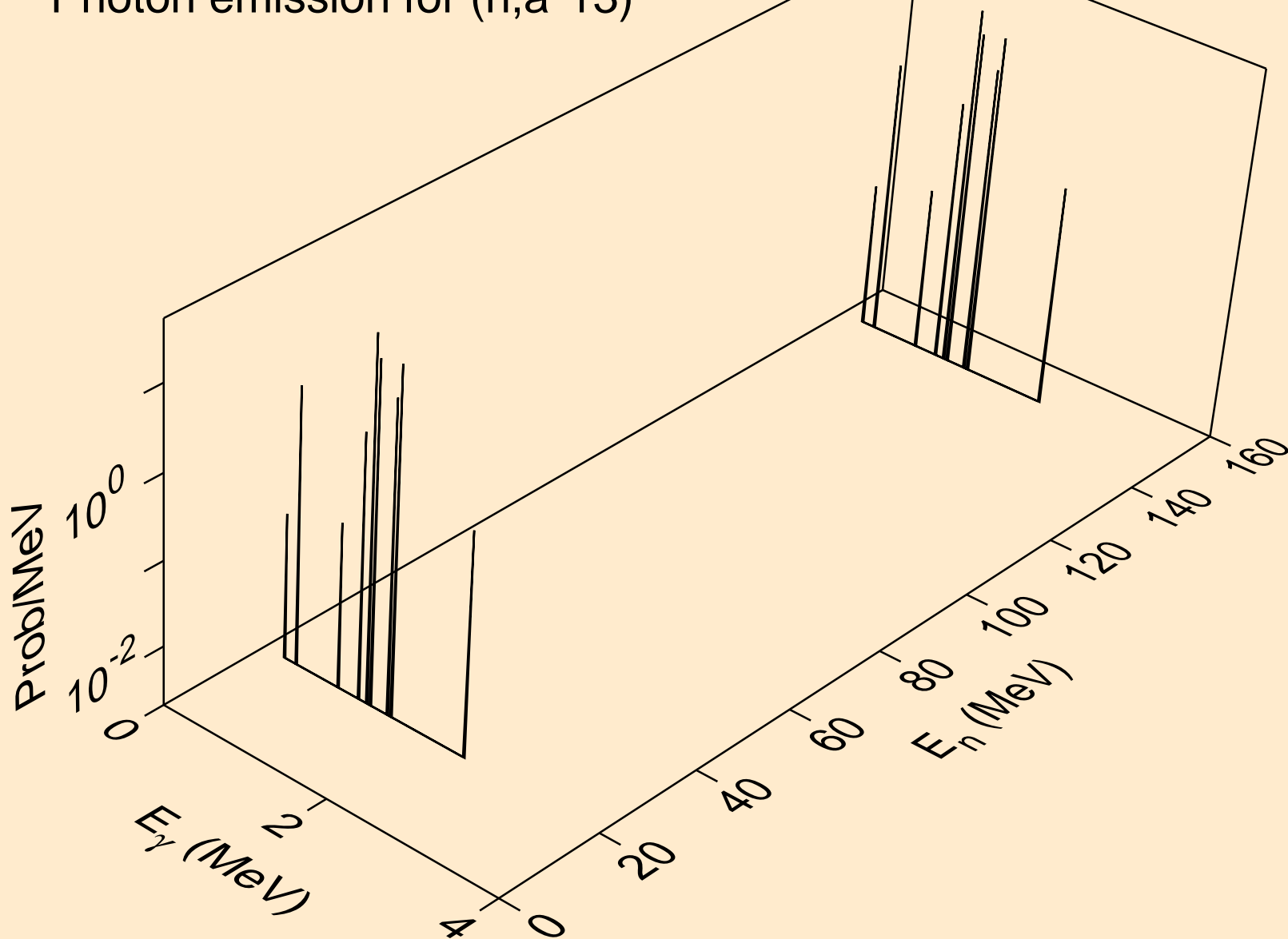

20-CA-42 FOR FENDL-3.1 FROM FENDL-3.1 WITH NJOY2012.50+  
Photon emission for (n,a\*14)

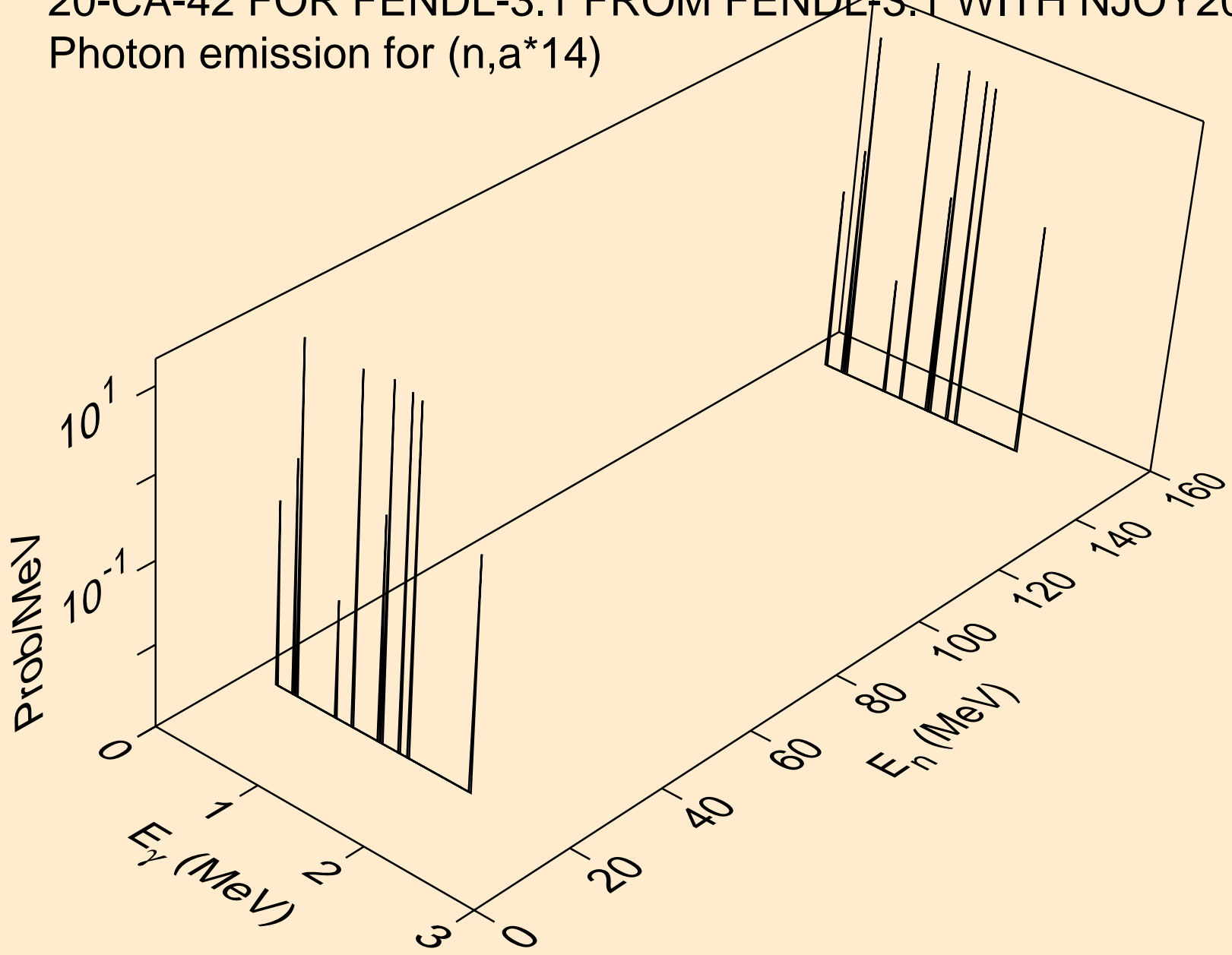

20-CA-42 FOR FENDL-3.1 FROM FENDL-3.1 WITH NJOY2012.50+  
Photon emission for (n,a\*15)

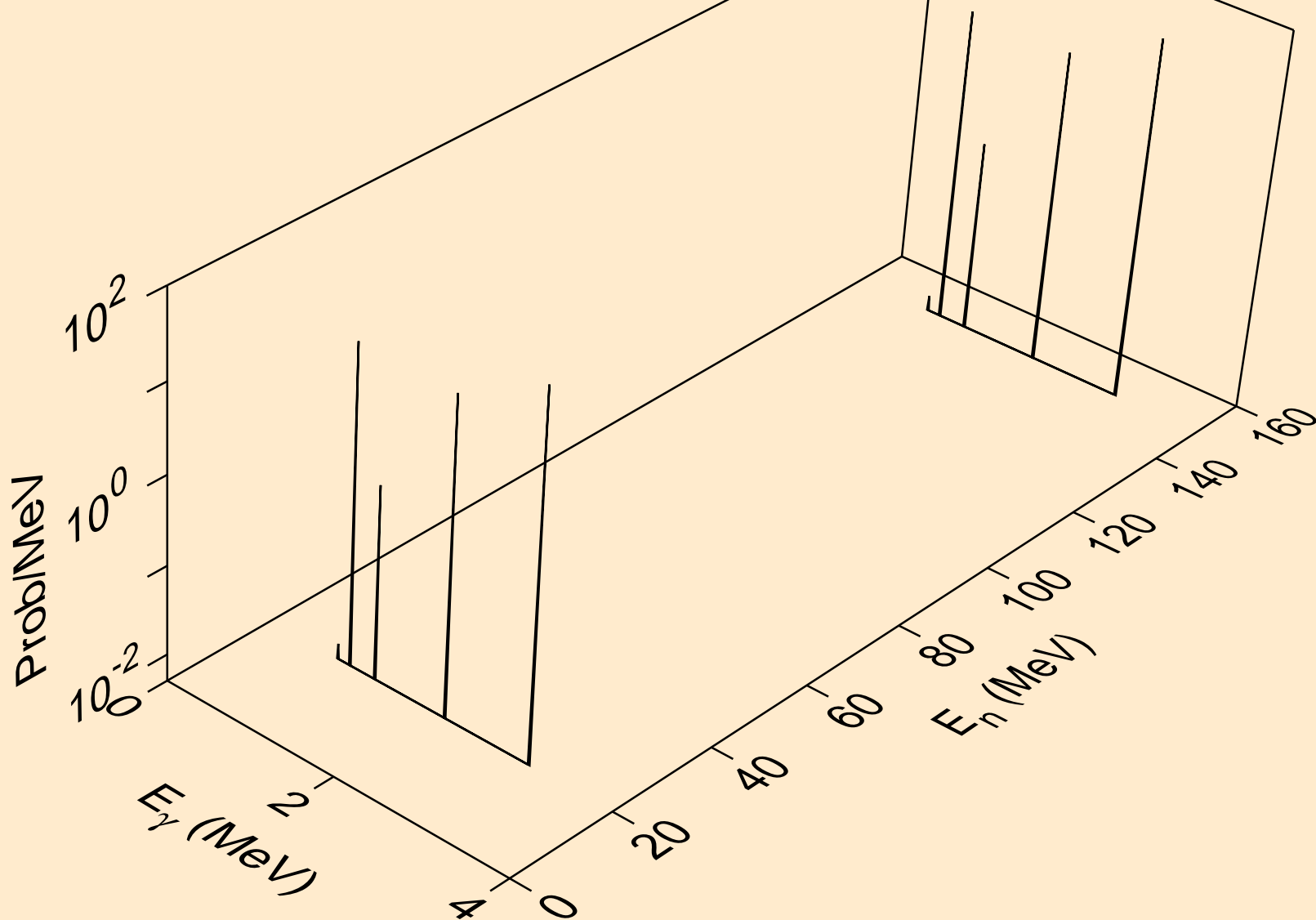

20-CA-42 FOR FENDL-3.1 FROM FENDL-3.1 WITH NJOY2012.50+  
Photon emission for (n,a\*16)

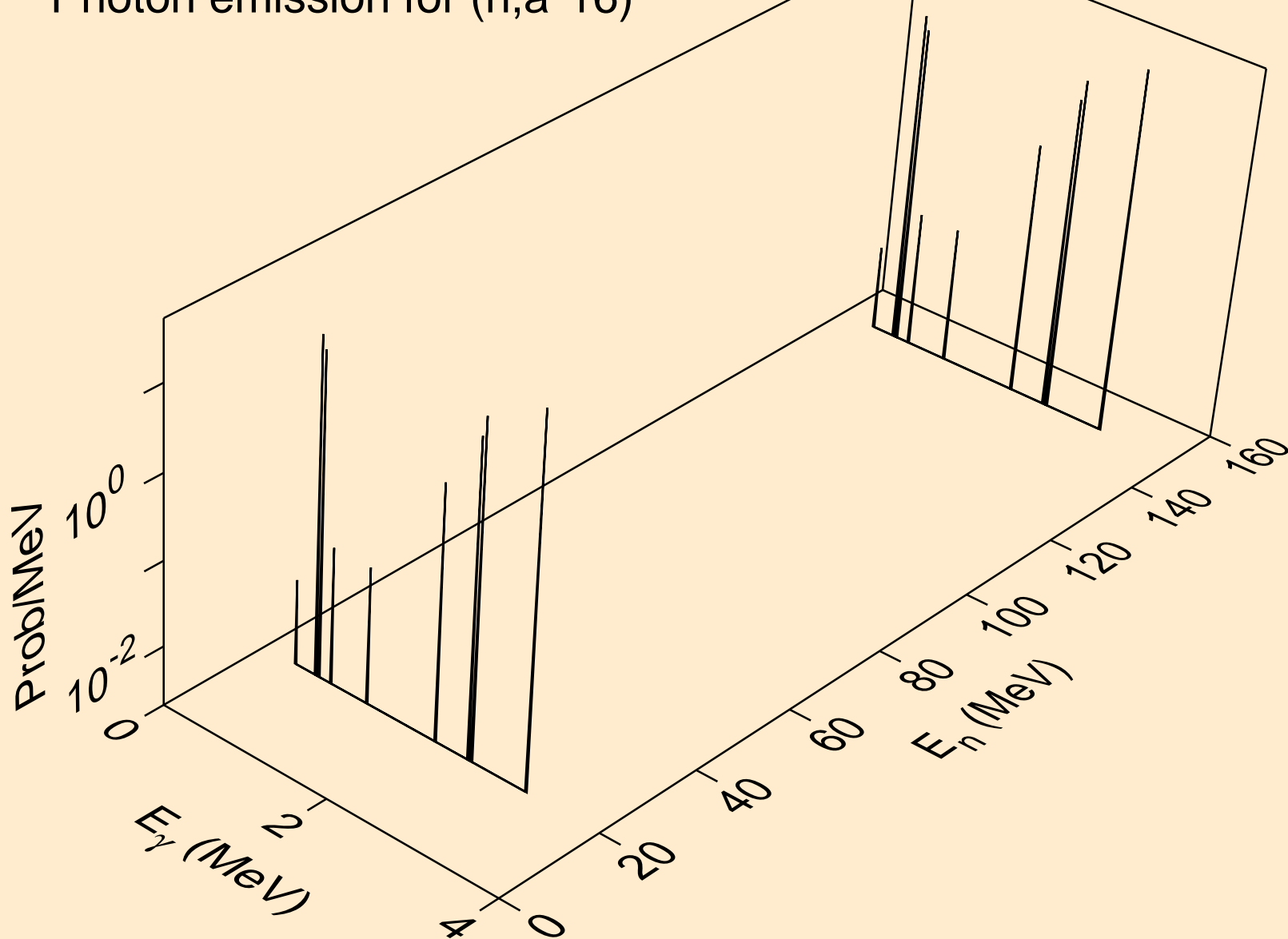

20-CA-42 FOR FENDL-3.1 FROM FENDL-3.1 WITH NJOY2012.50+  
Photon emission for (n,a\*17)

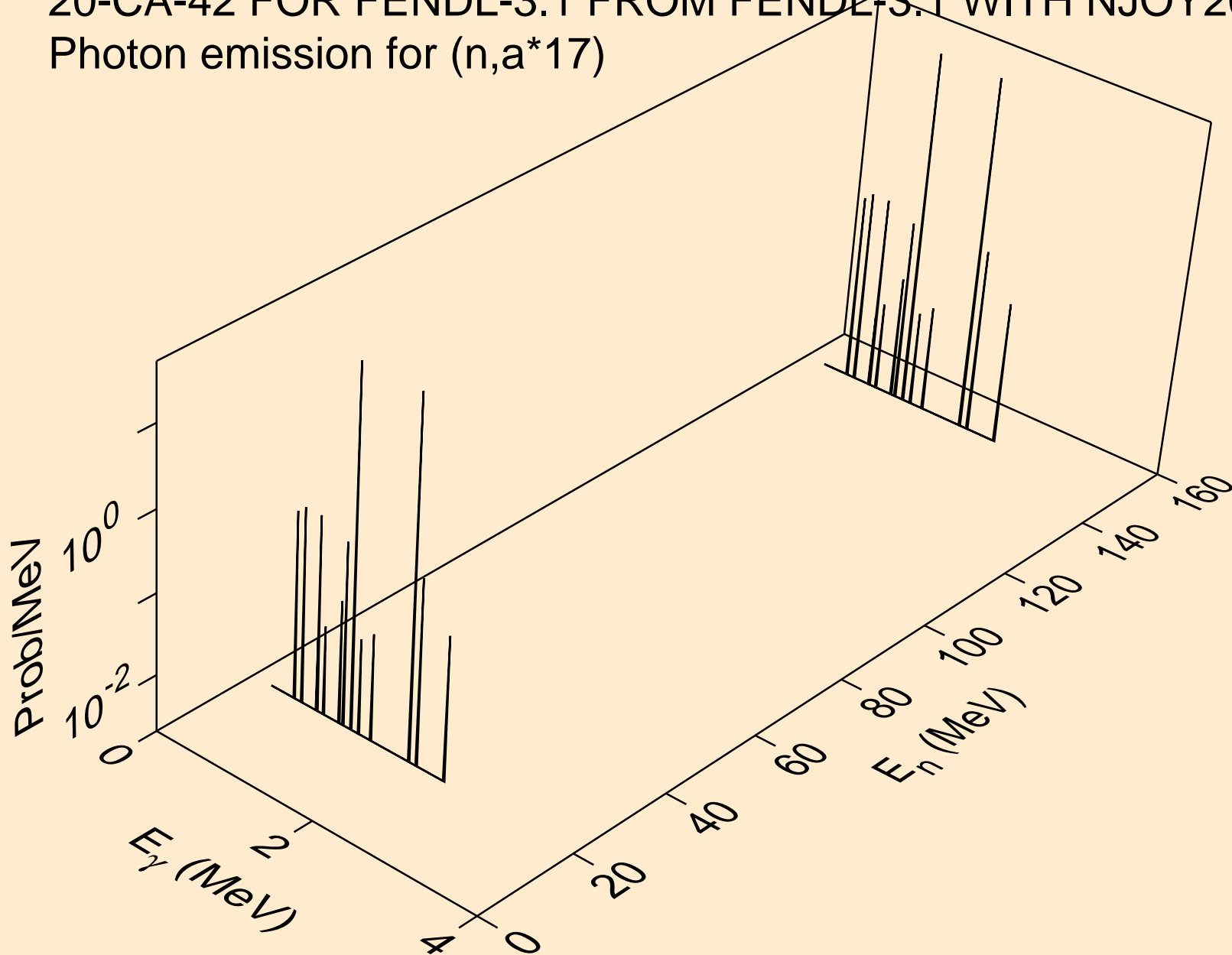

20-CA-42 FOR FENDL-3.1 FROM FENDL-3.1 WITH NJOY2012.50+  
Photon emission for (n,a\*18)

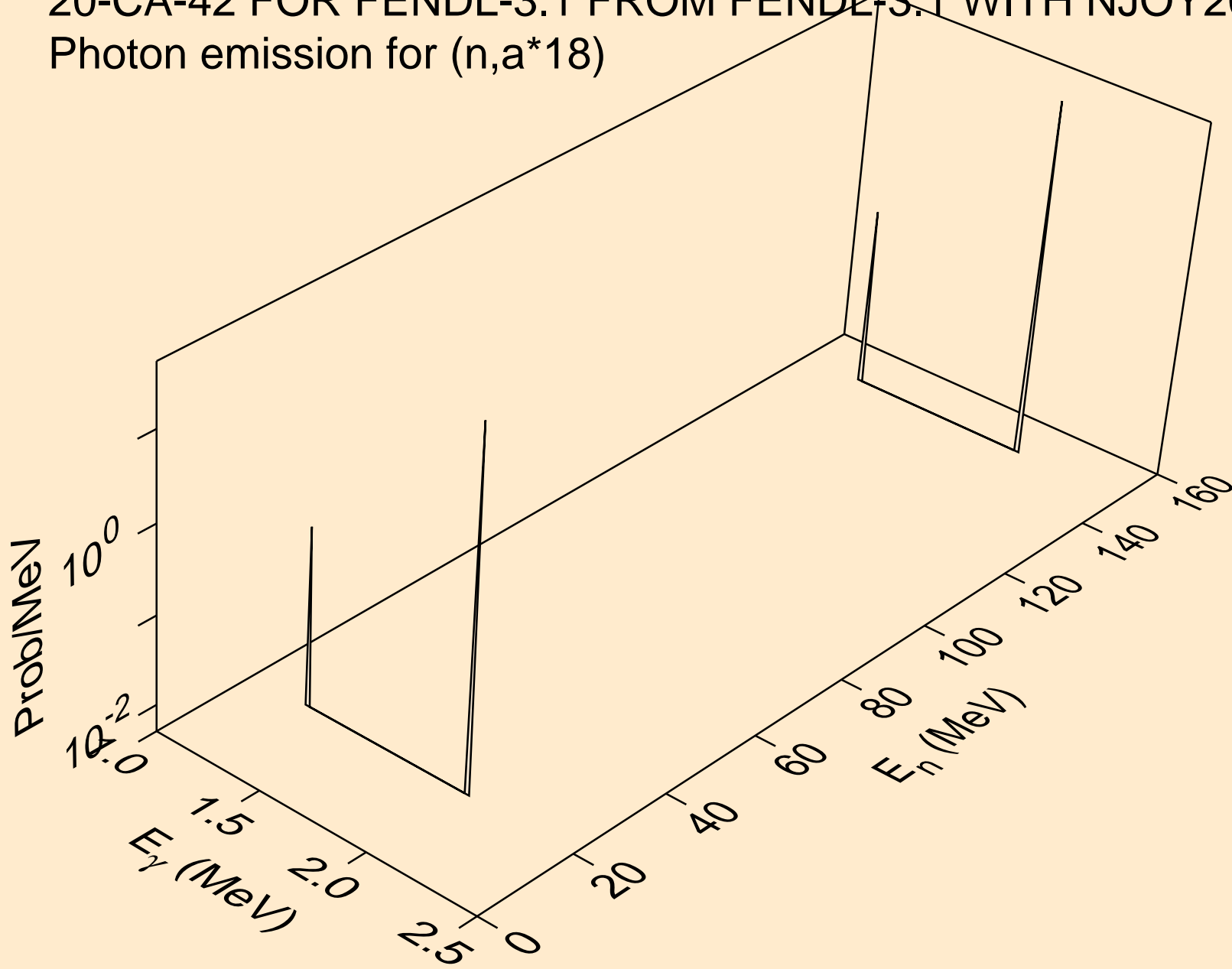

20-CA-42 FOR FENDL-3.1 FROM FENDL-3.1 WITH NJOY2012.50+  
Photon emission for (n,a\*19)

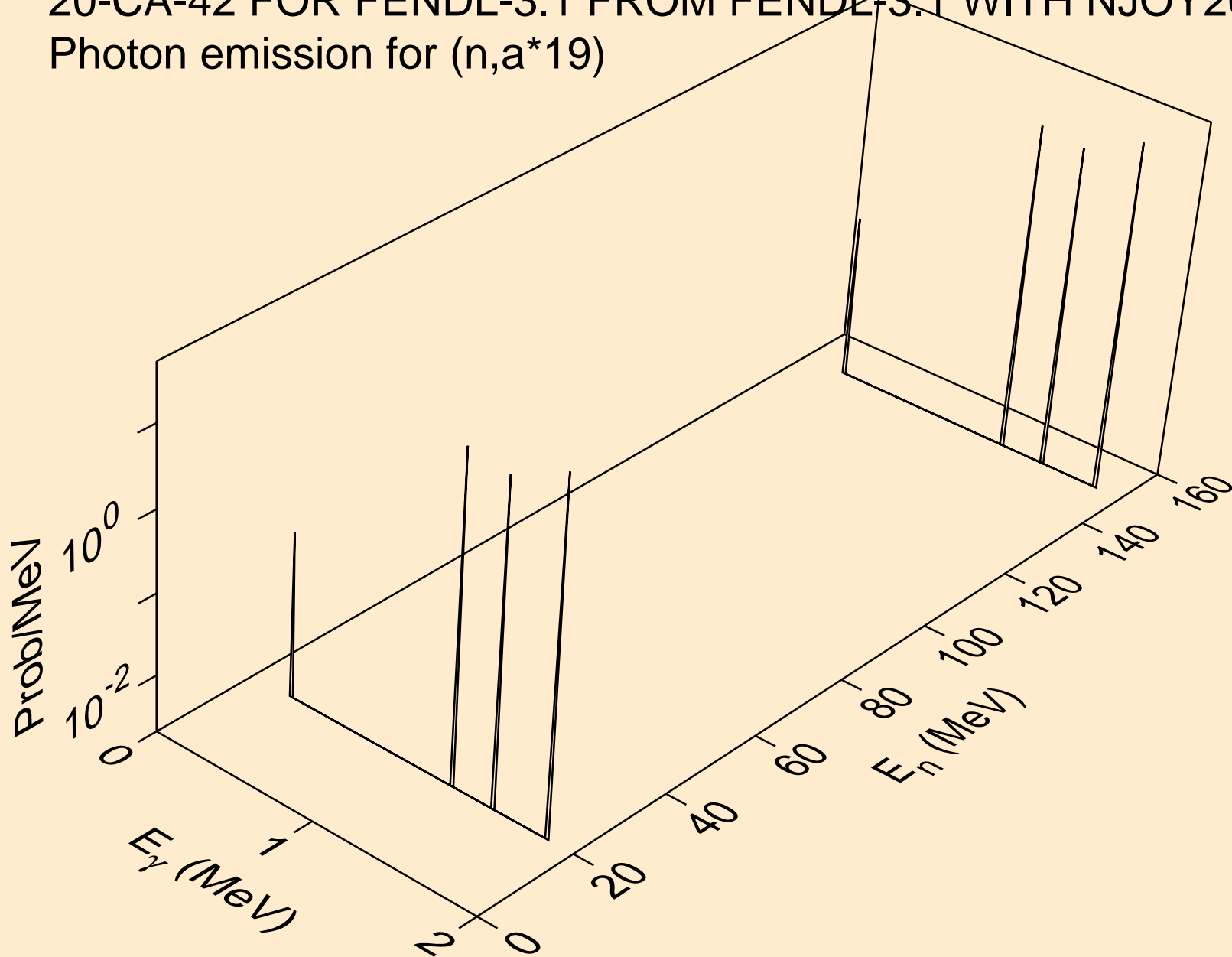

20-CA-42 FOR FENDL-3.1 FROM FENDL-3.1 WITH NJOY2012.50+  
Photon emission for (n,a\*23)

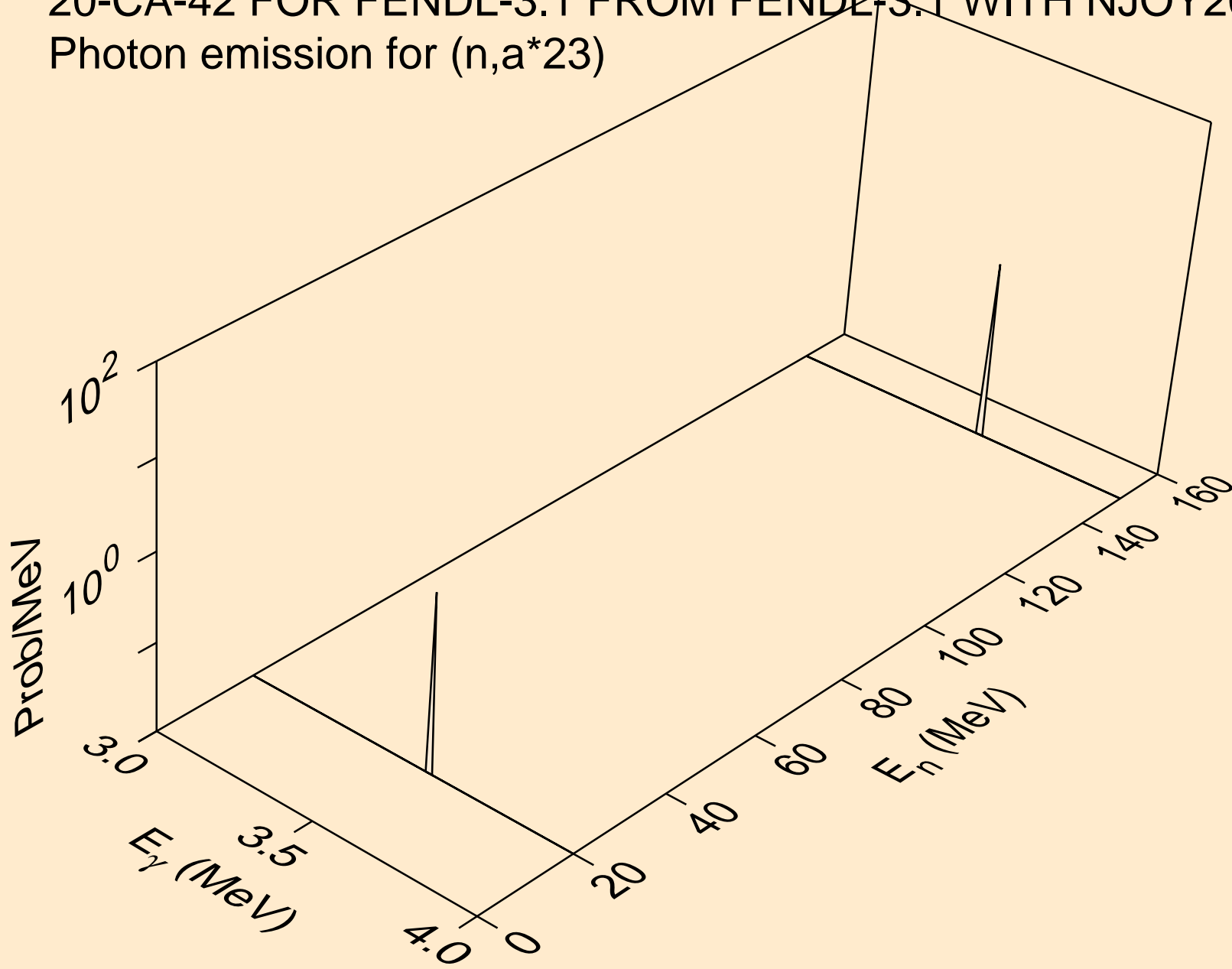



20-CA-42 FOR FENDL-3.1 FROM FENDL-3.1 WITH NJOY2012.50+  
Photon emission for (n,a\*30)

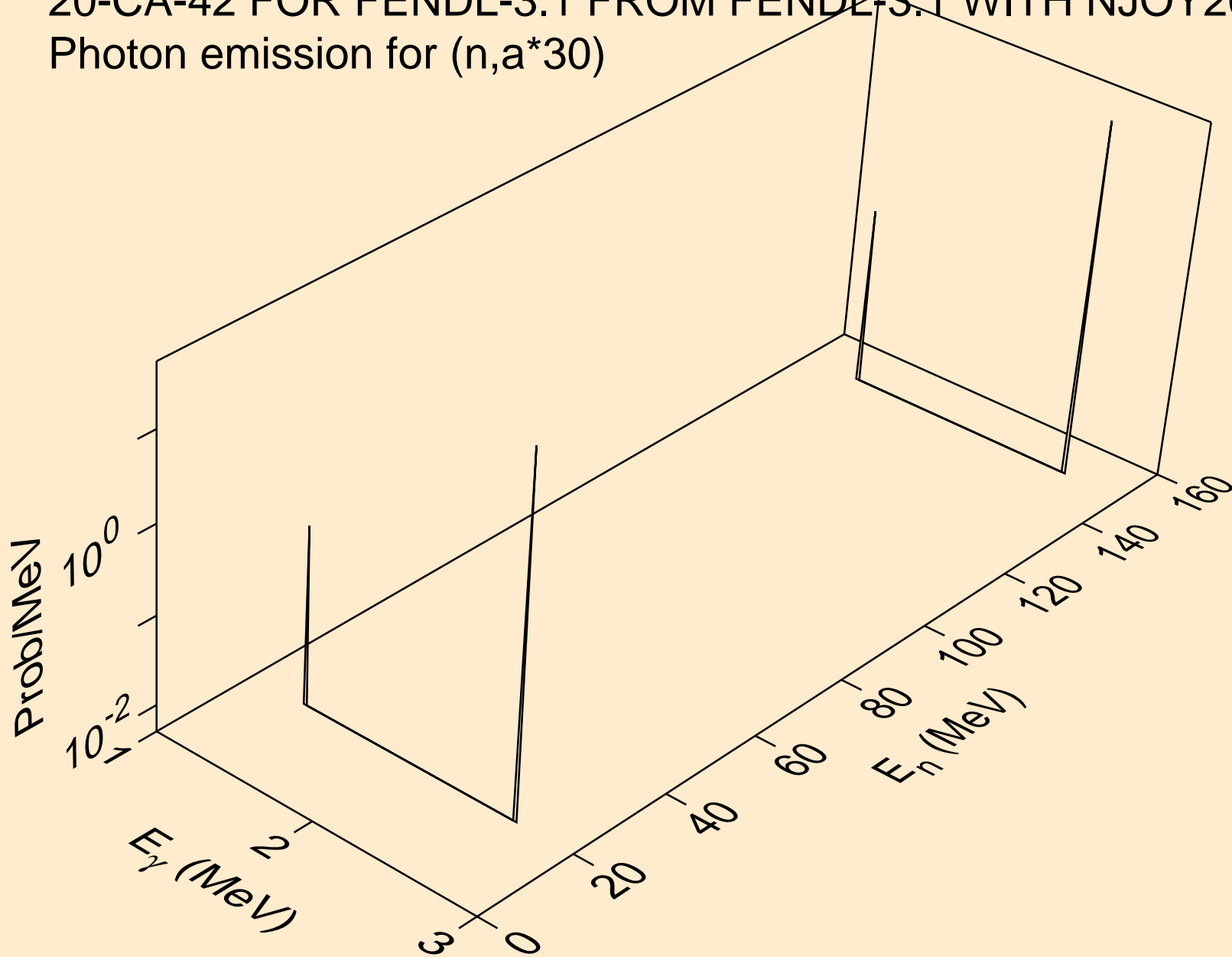

20-CA-42 FOR FENDL-3.1 FROM FENDL-3.1 WITH NJOY2012.50+  
Photon emission for (n,a\*c)

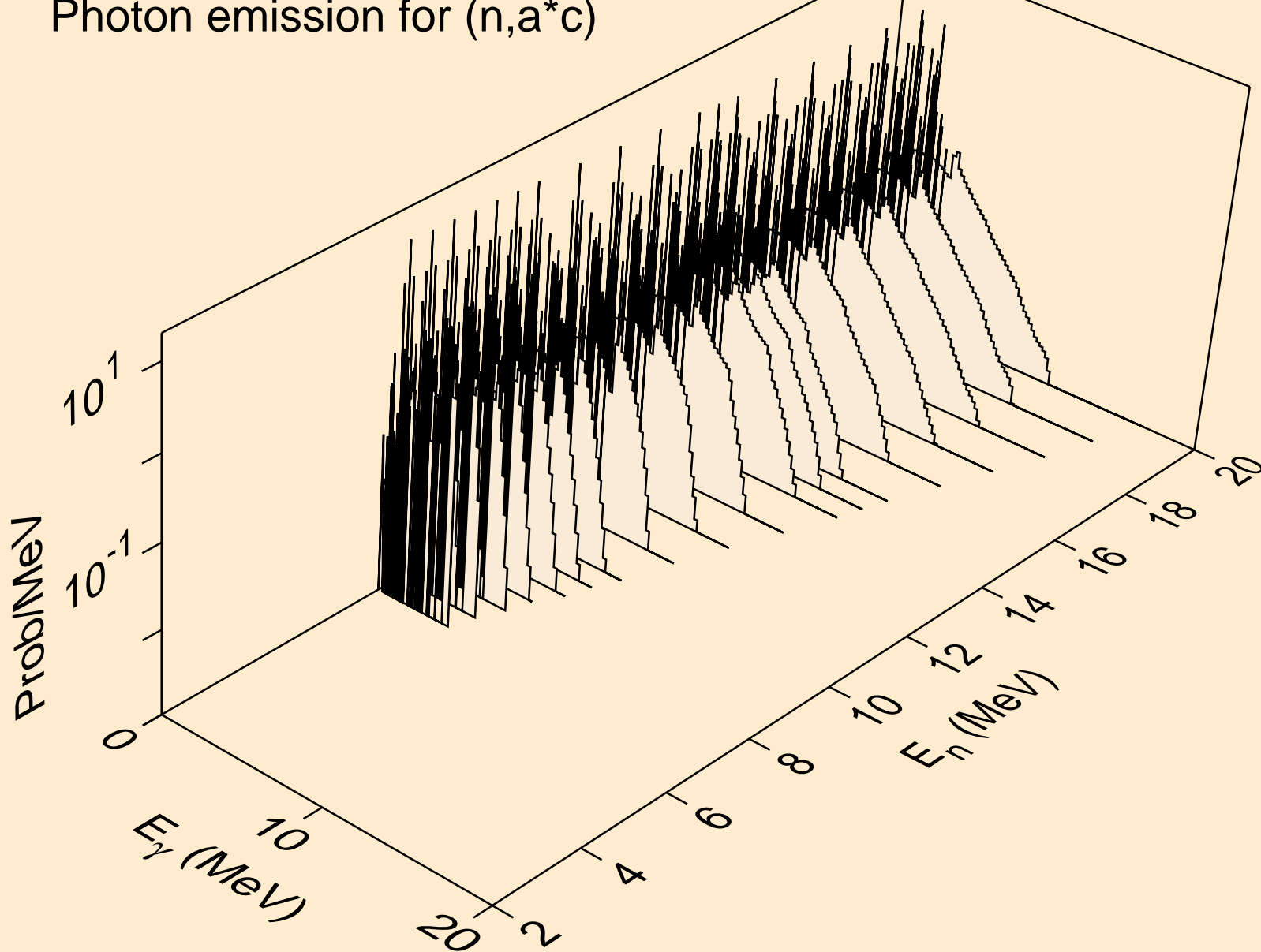

20-CA-42 FOR FENDL-3.1 FROM FENDL-3.1 WITH NJOY2012.50+  
thermal capture photon spectrum

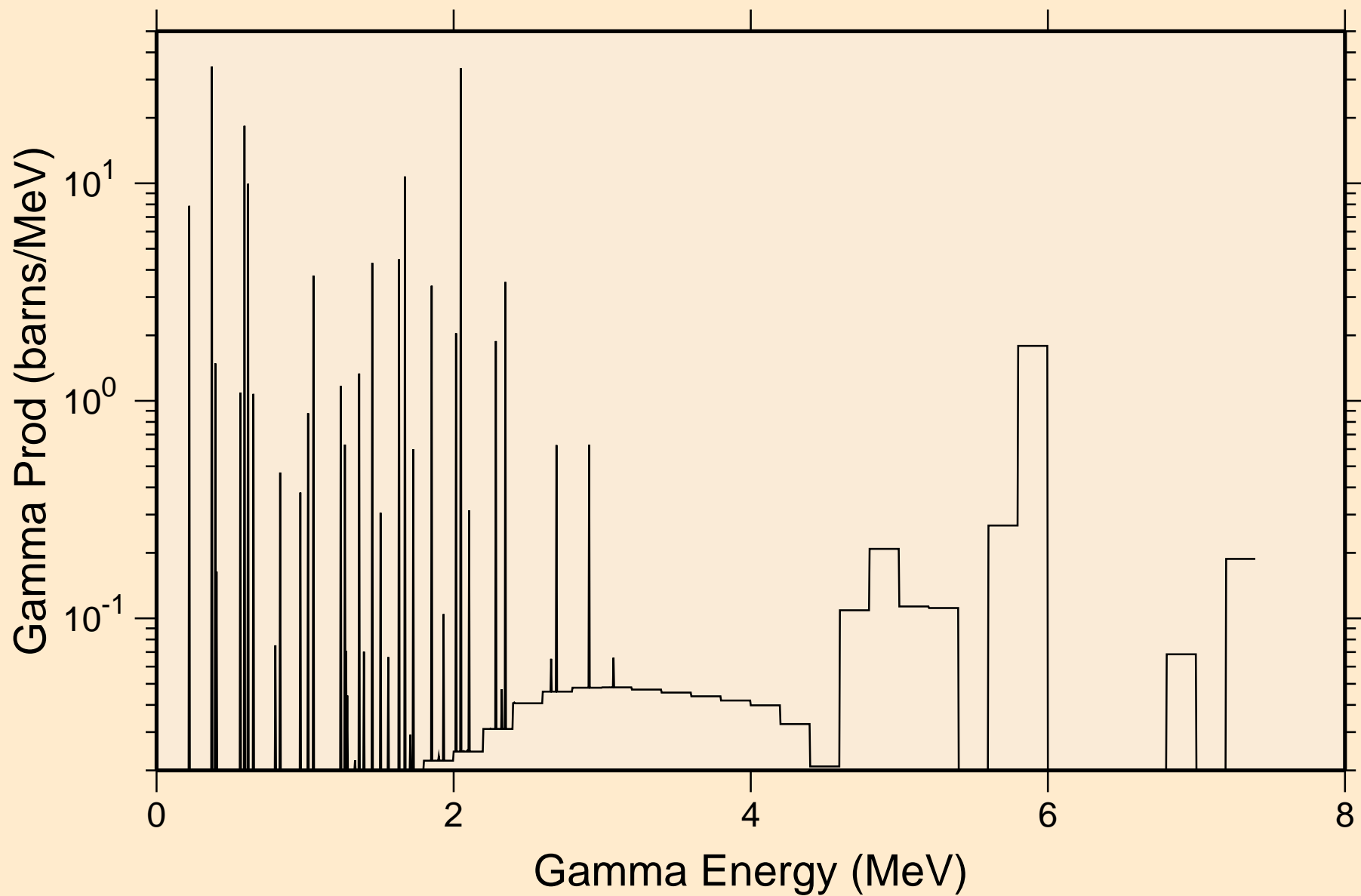

20-CA-42 FOR FENDL-3.1 FROM FENDL-3.1 WITH NJOY2012.50+  
14 MeV photon spectrum

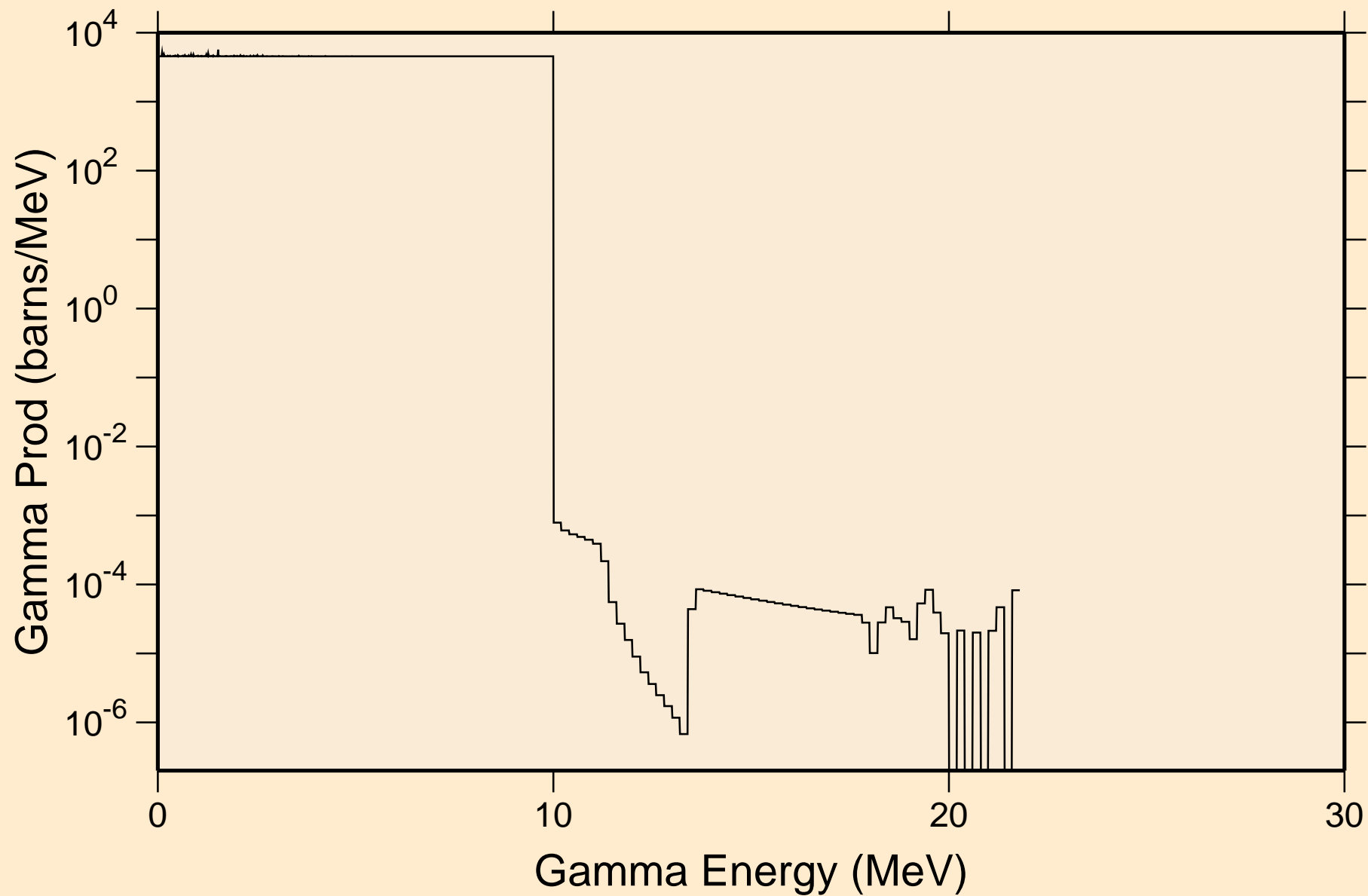

# 20-CA-42 FOR FENDL-3.1 FROM FENDL-3.1 WITH NJOY2012.50+

## Particle heating contributions

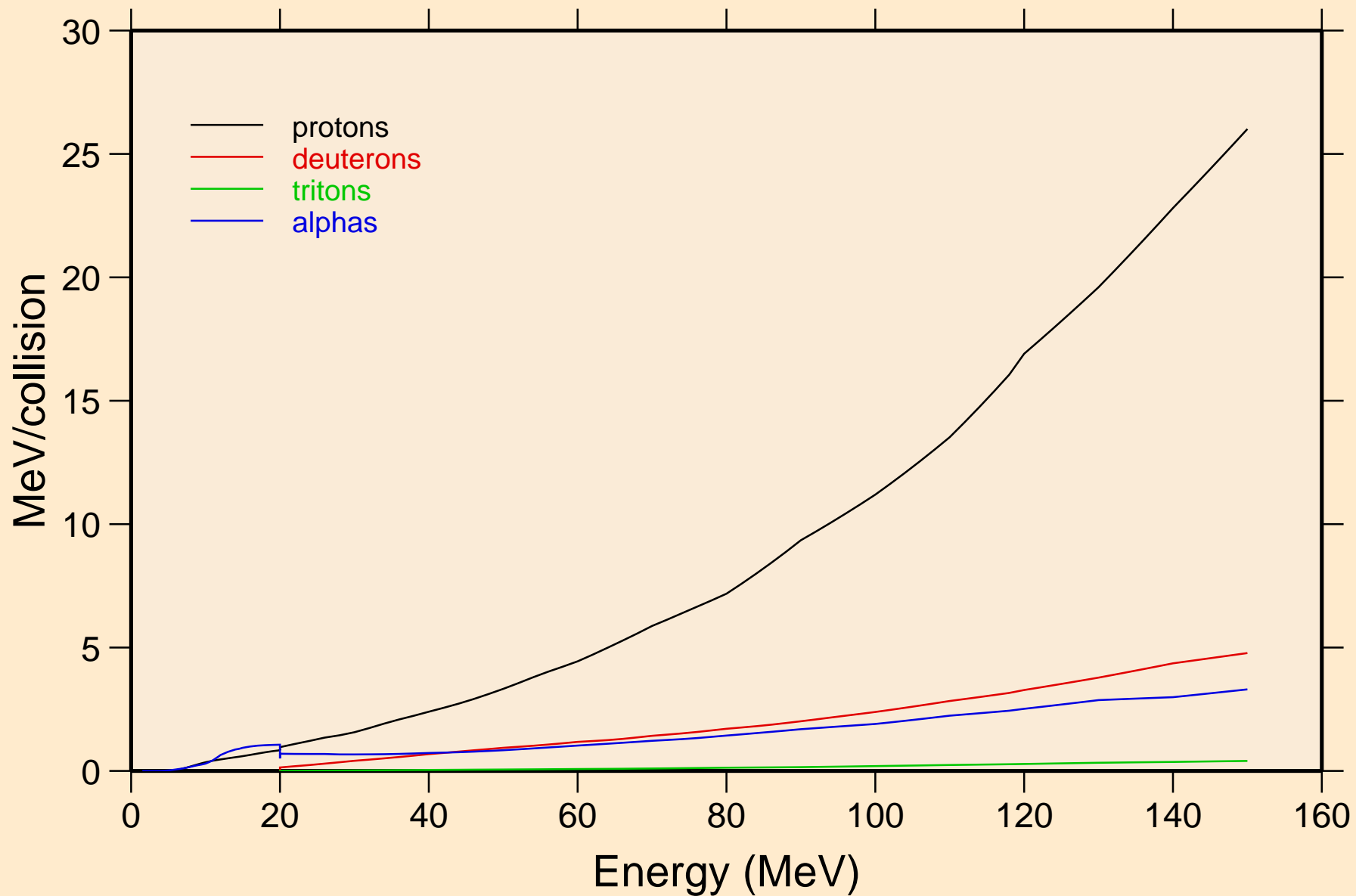

# 20-CA-42 FOR FENDL-3.1 FROM FENDL-3.1 WITH NJOY2012.50+ Recoil Heating

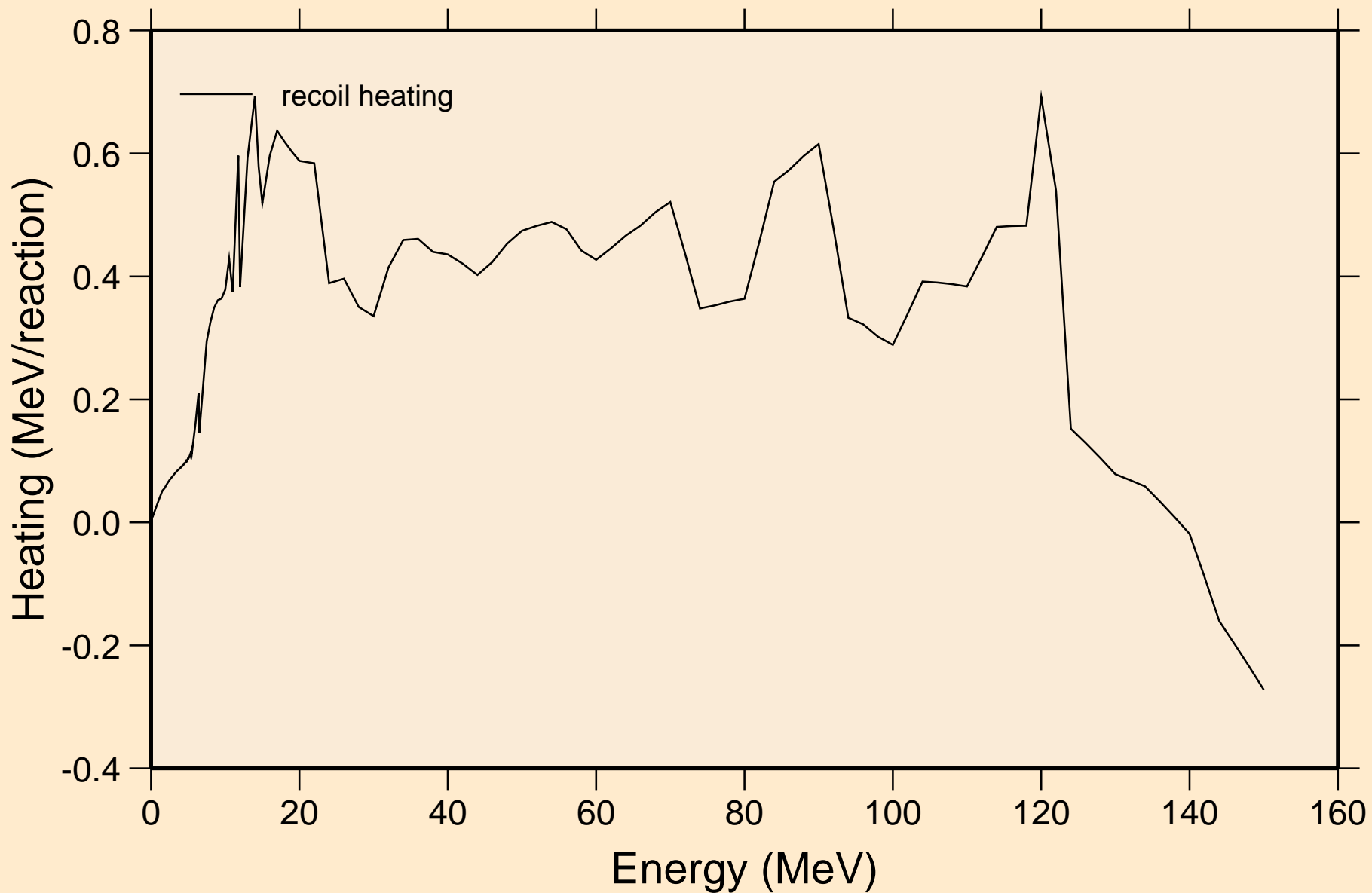

# 20-CA-42 FOR FENDL-3.1 FROM FENDL-3.1 WITH NJOY2012.50+

## Particle production cross sections

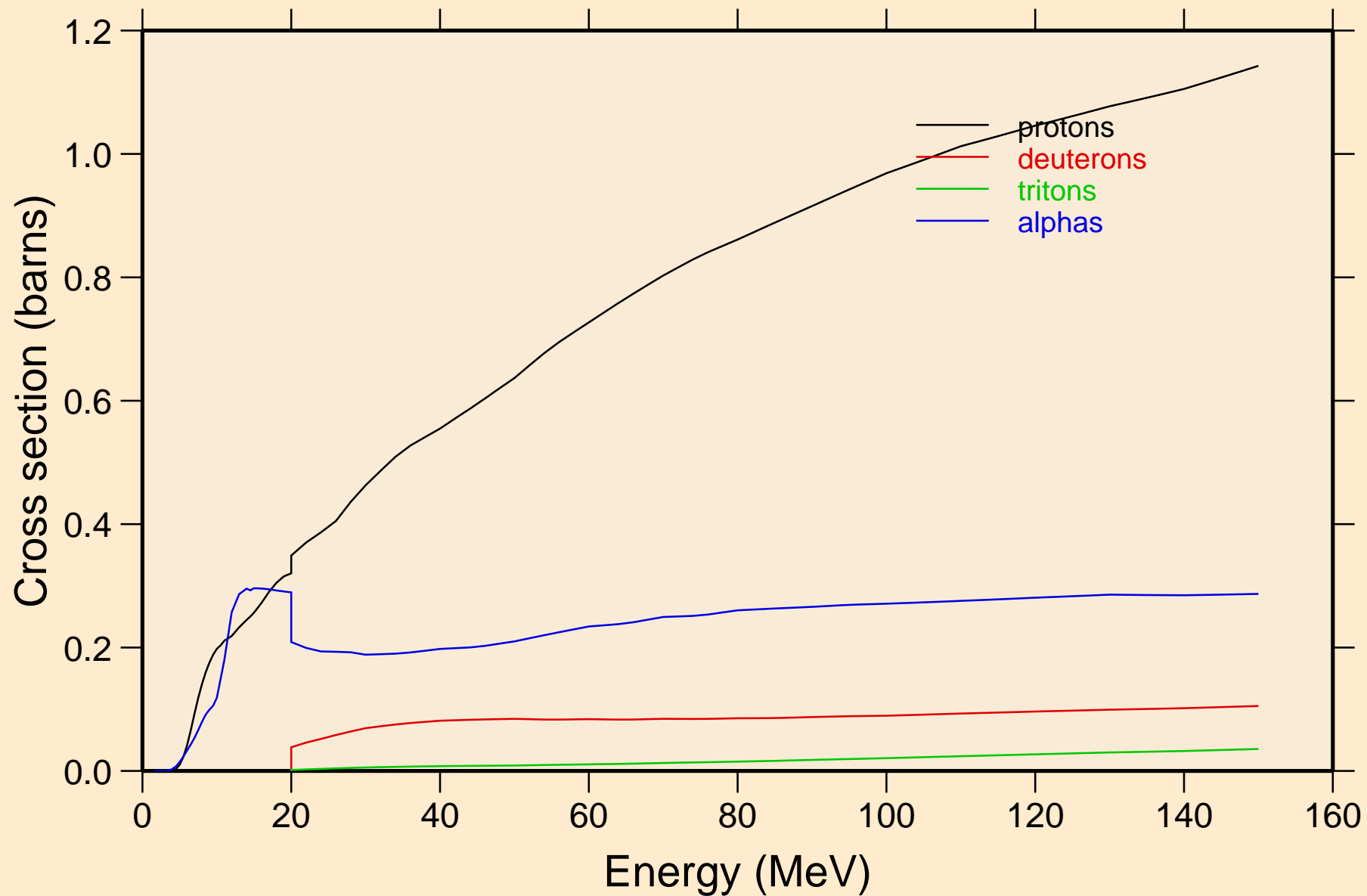

20-CA-42 FOR FENDL-3.1 FROM FENDL-3.1 WITH NJOY2012.50+  
protons from (n,x)

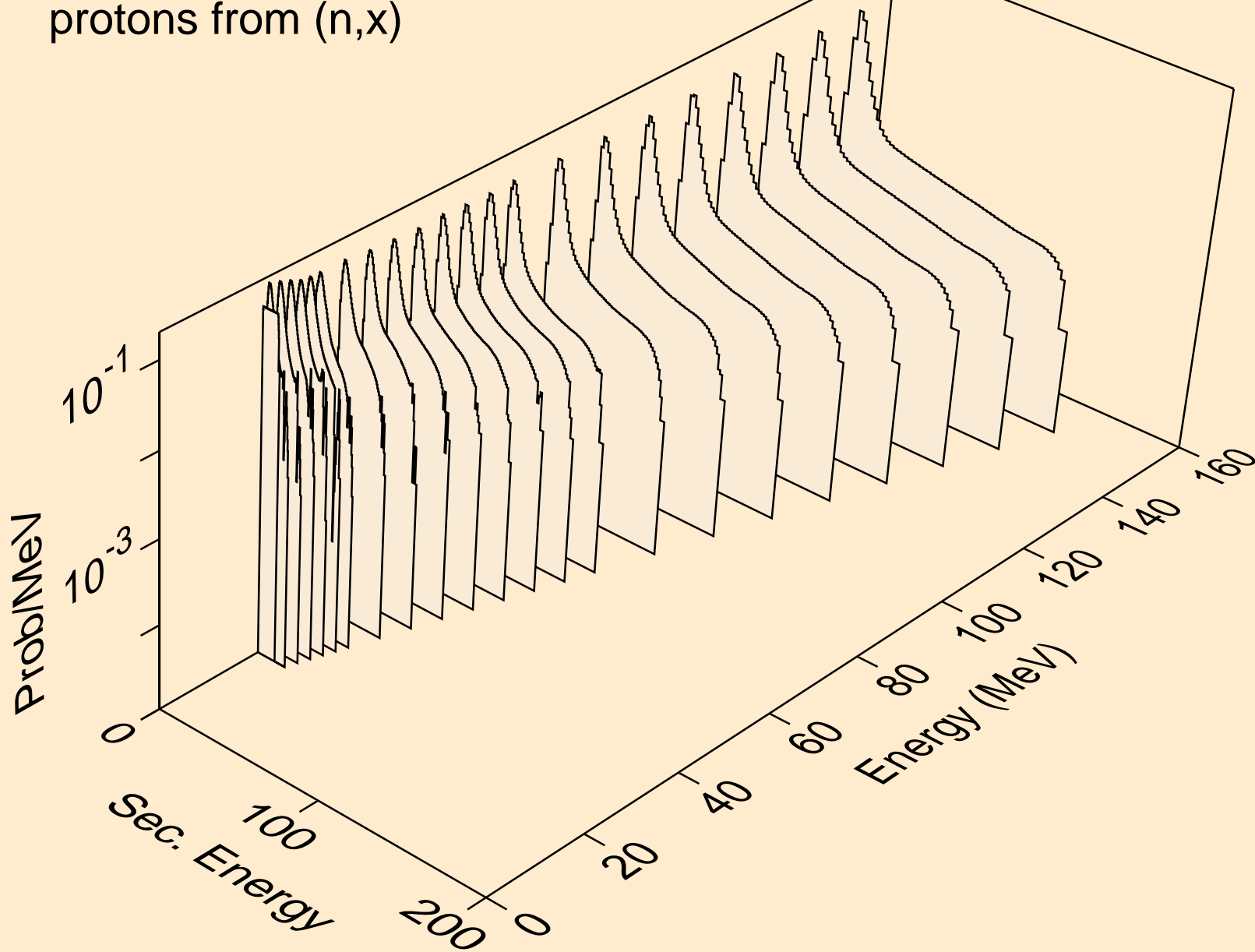



20-CA-42 FOR FENDL-3.1 FROM FENDL-3.1 WITH NJOY2012.50+  
protons from (n,n\*)p

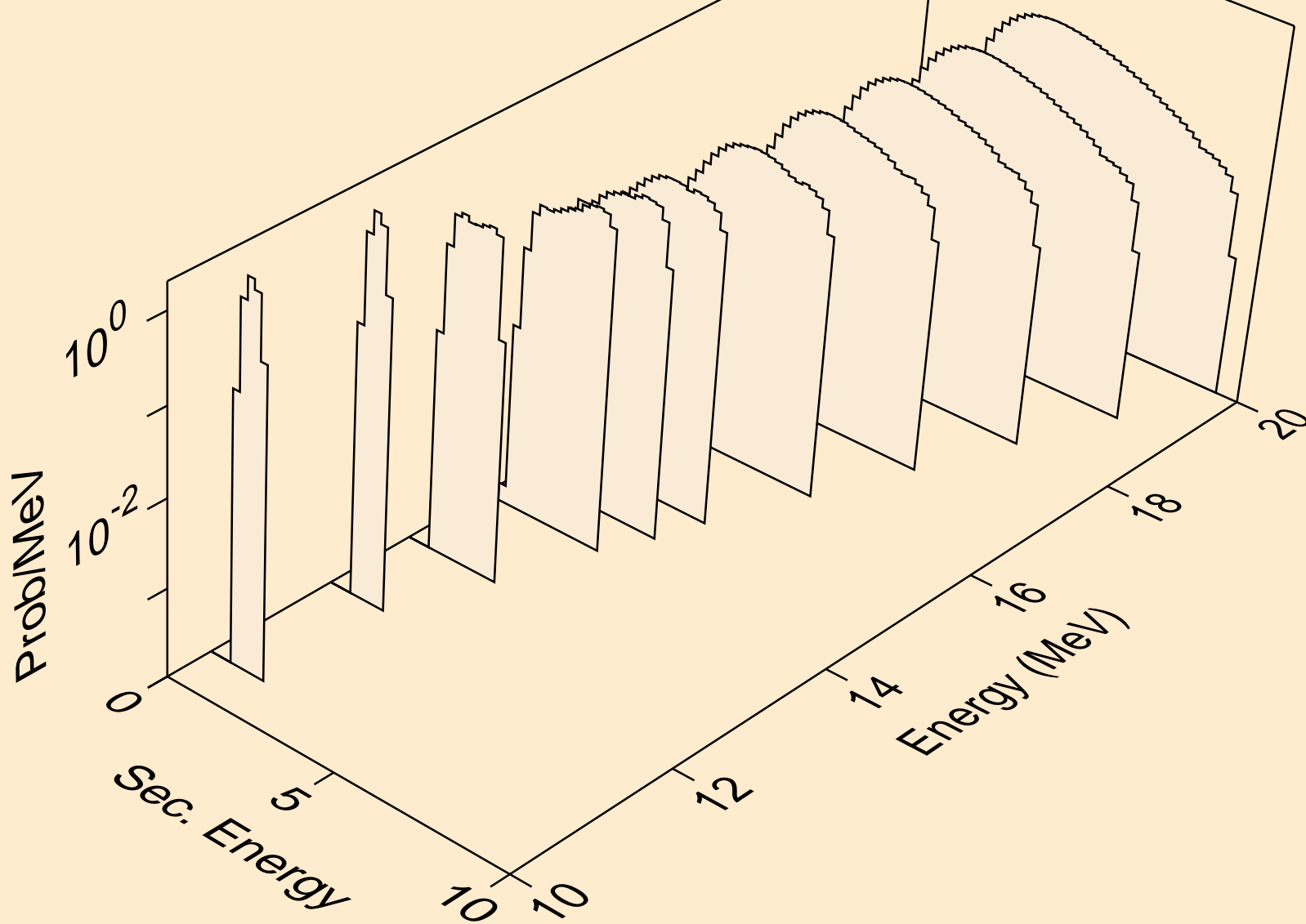

20-CA-42 FOR FENDL-3.1 FROM FENDL-3.1 WITH NJOY2012.50+  
protons from (n,p\*c)

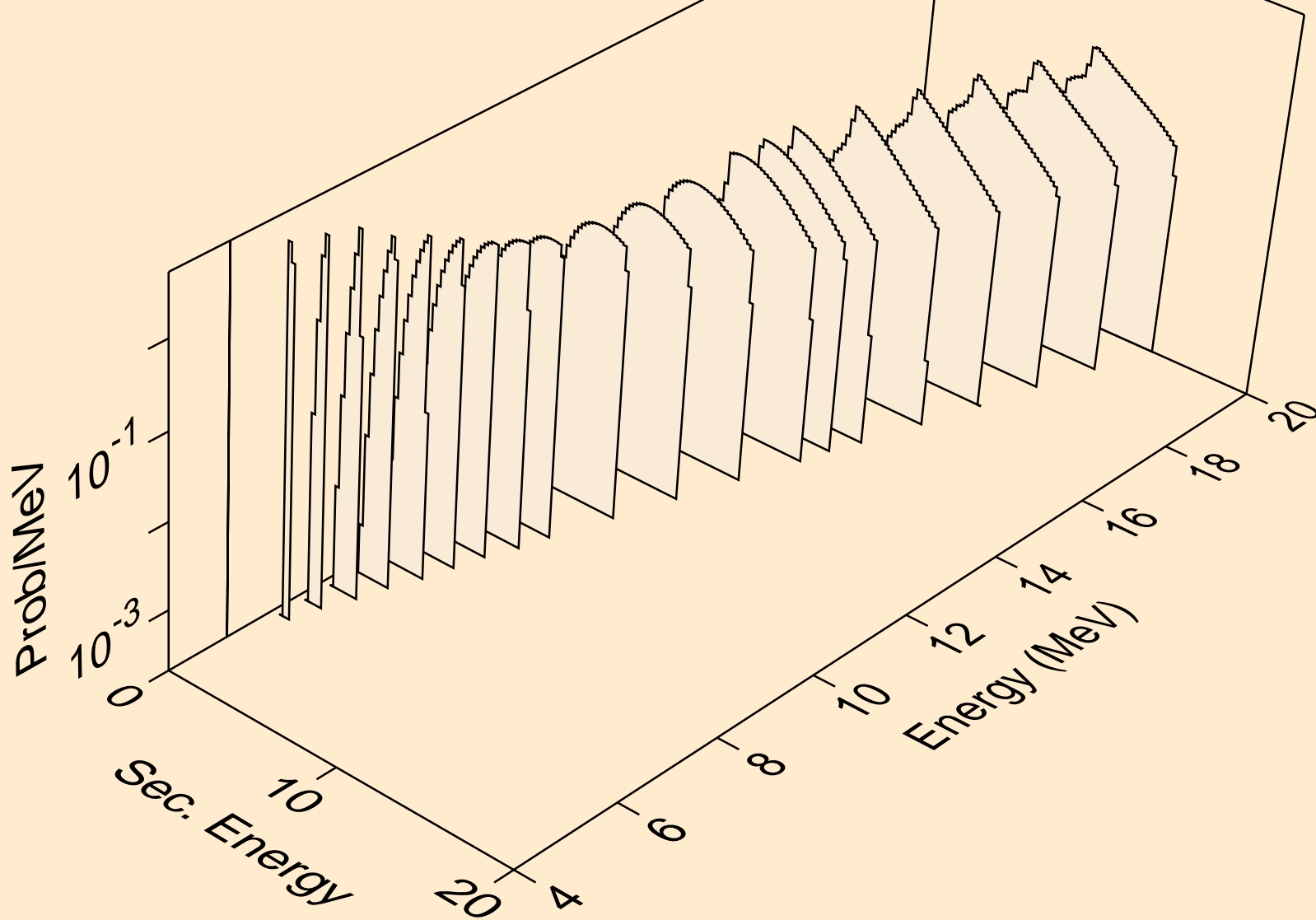

20-CA-42 FOR FENDL-3.1 FROM FENDL-3.1 WITH NJOY2012.50+  
deuterons from (n,x)

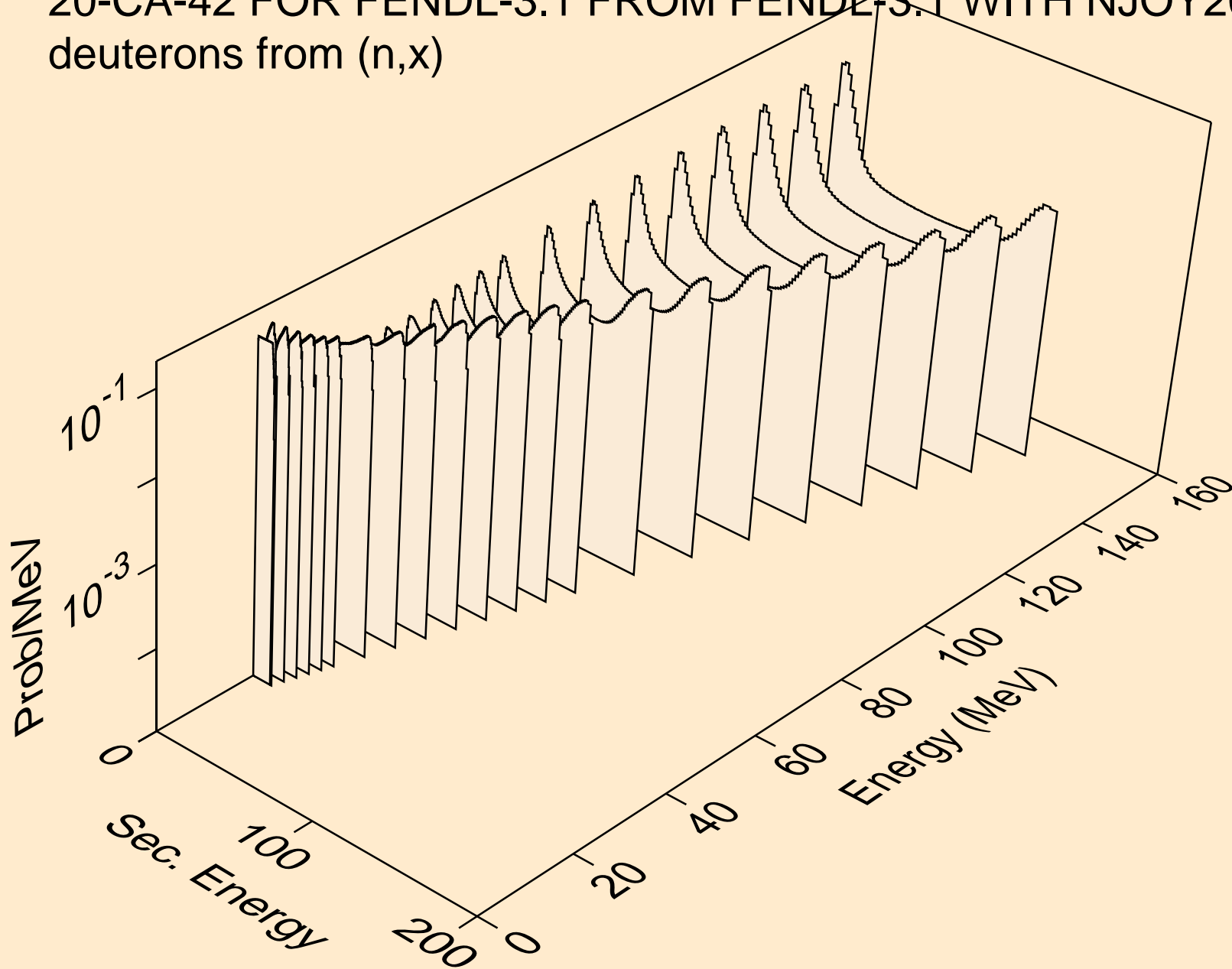

20-CA-42 FOR FENDL-3.1 FROM FENDL-3.1 WITH NJOY2012.50+  
tritons from (n,x)

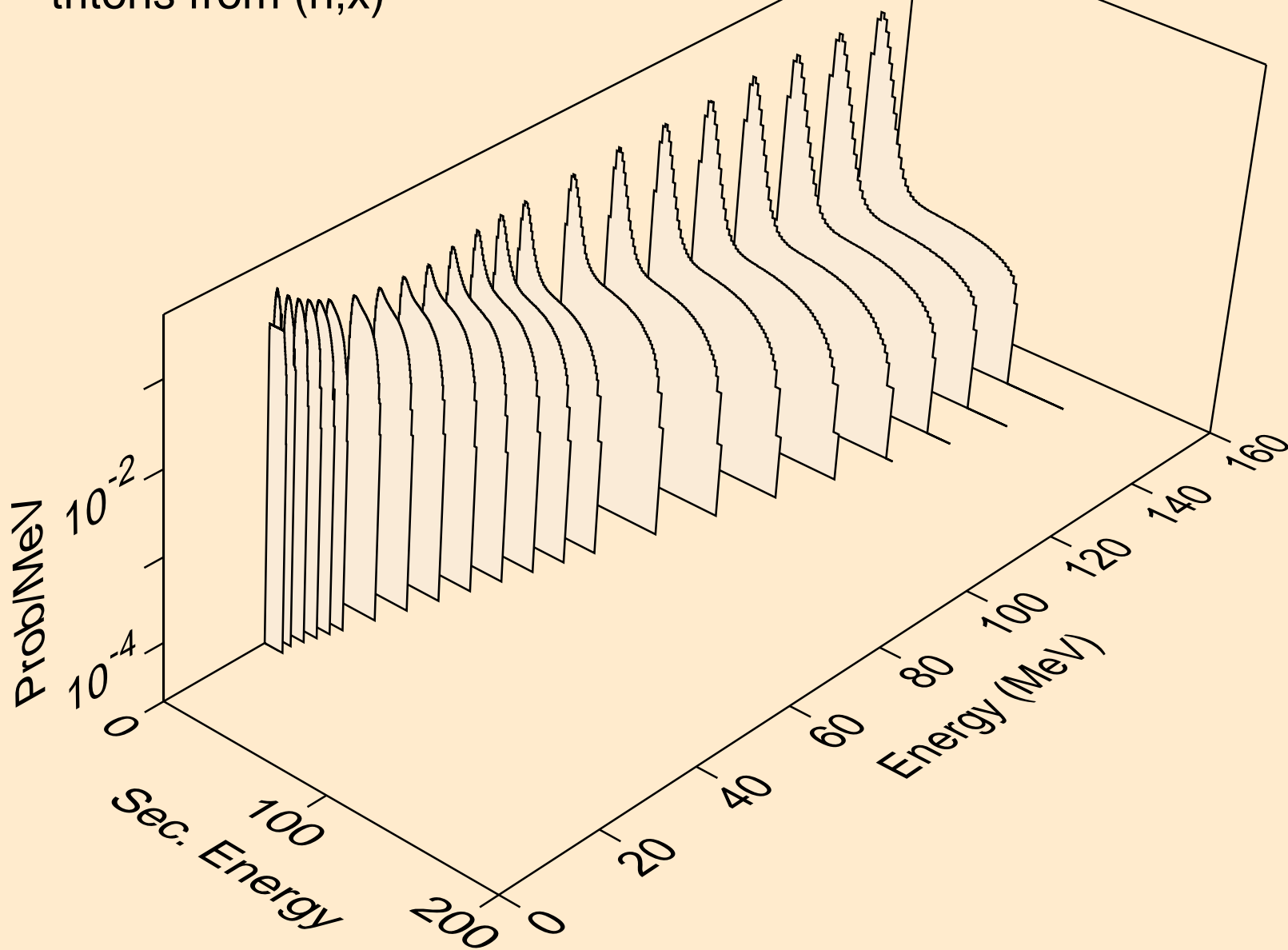

20-CA-42 FOR FENDL-3.1 FROM FENDL-3.1 WITH NJOY2012.50+  
alphas from (n,x)

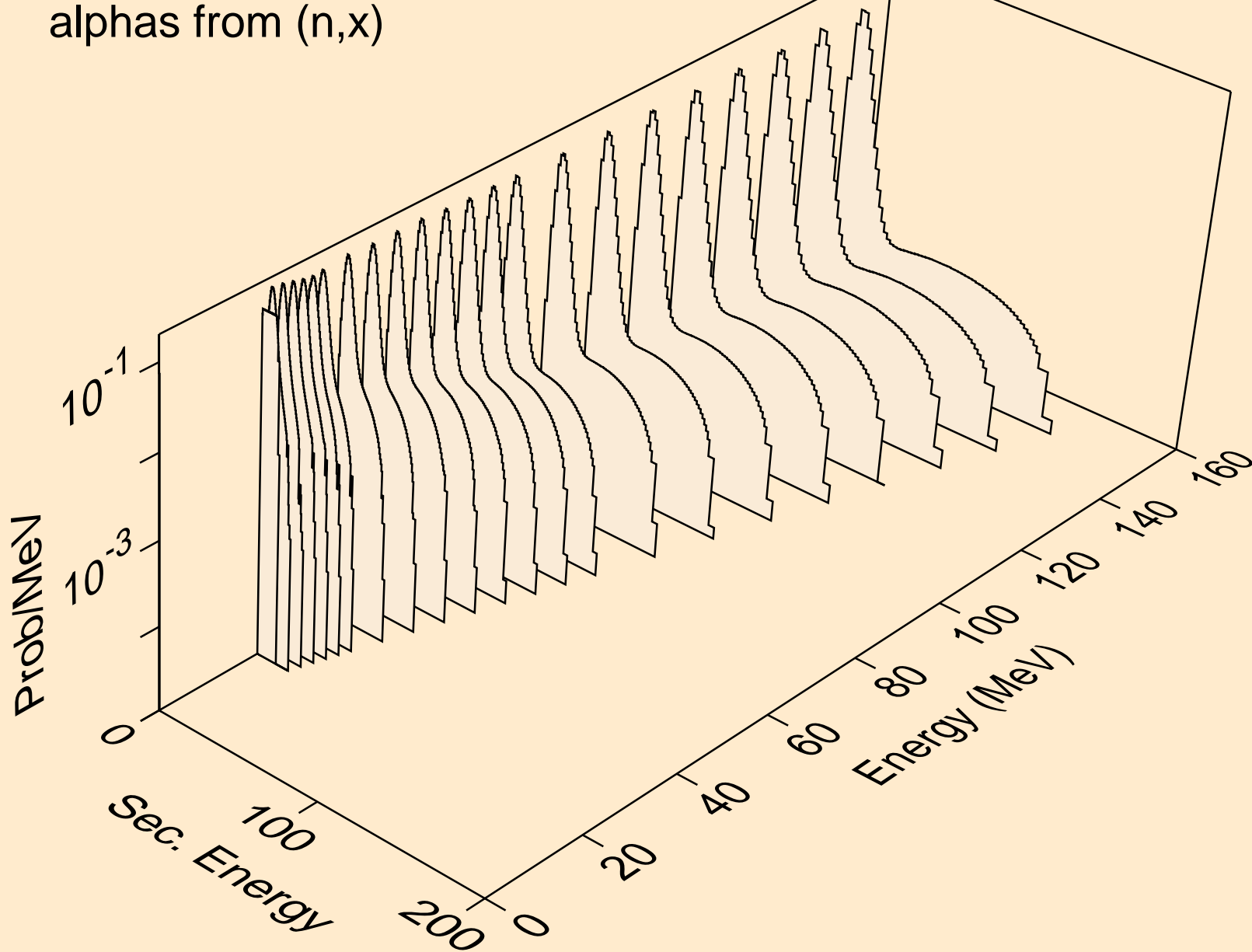

20-CA-42 FOR FENDL-3.1 FROM FENDL-3.1 WITH NJOY2012.50+  
alphas from (n,n\*)a

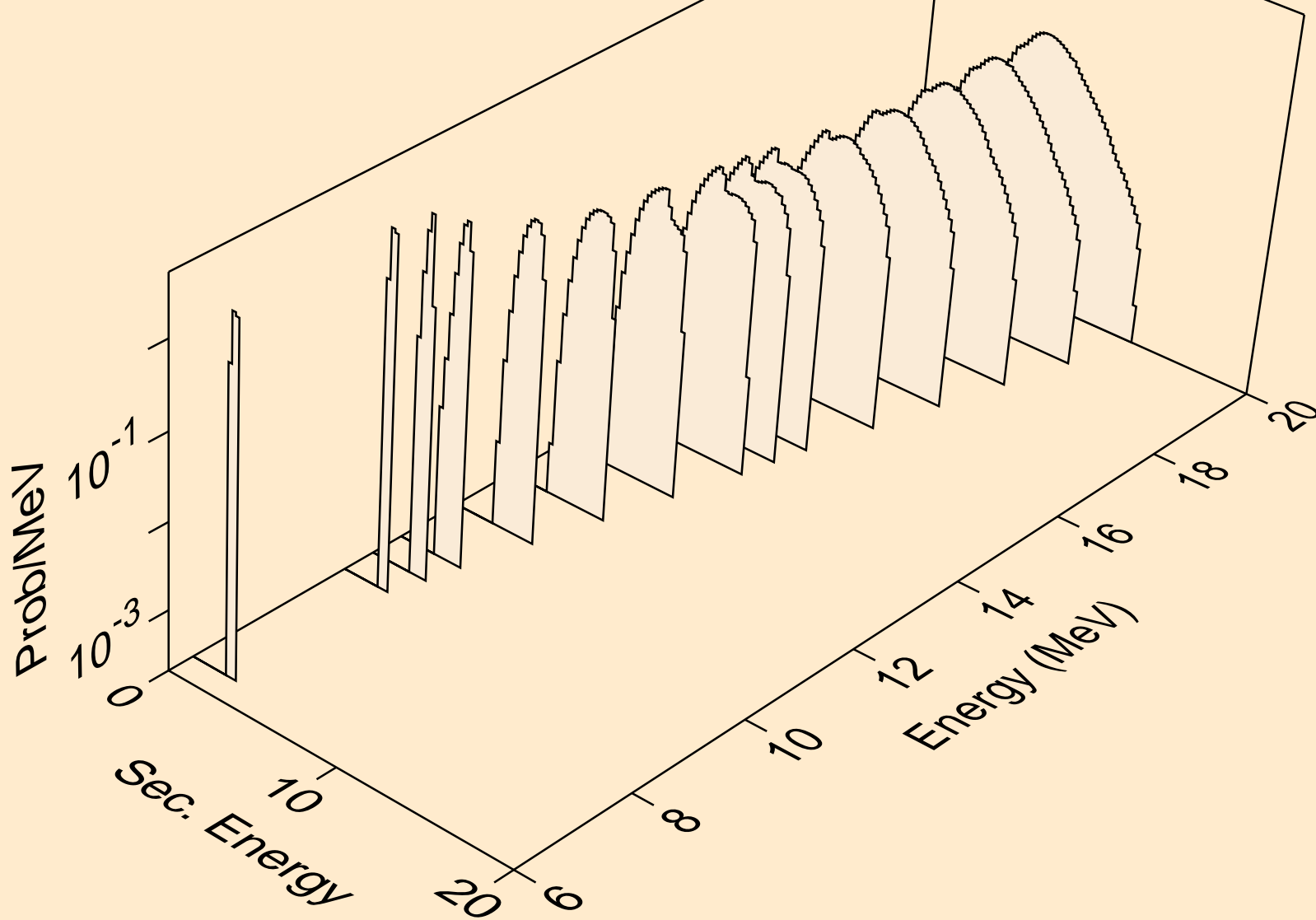

20-CA-42 FOR FENDL-3.1 FROM FENDL-3.1 WITH NJOY2012.50+  
alphas from (n,a\*c)

