

# 21-SC-45 FOR FENDL-3.1 FROM JEFF-3.1.1 WITH NJOY2012.50+

## Principal cross sections

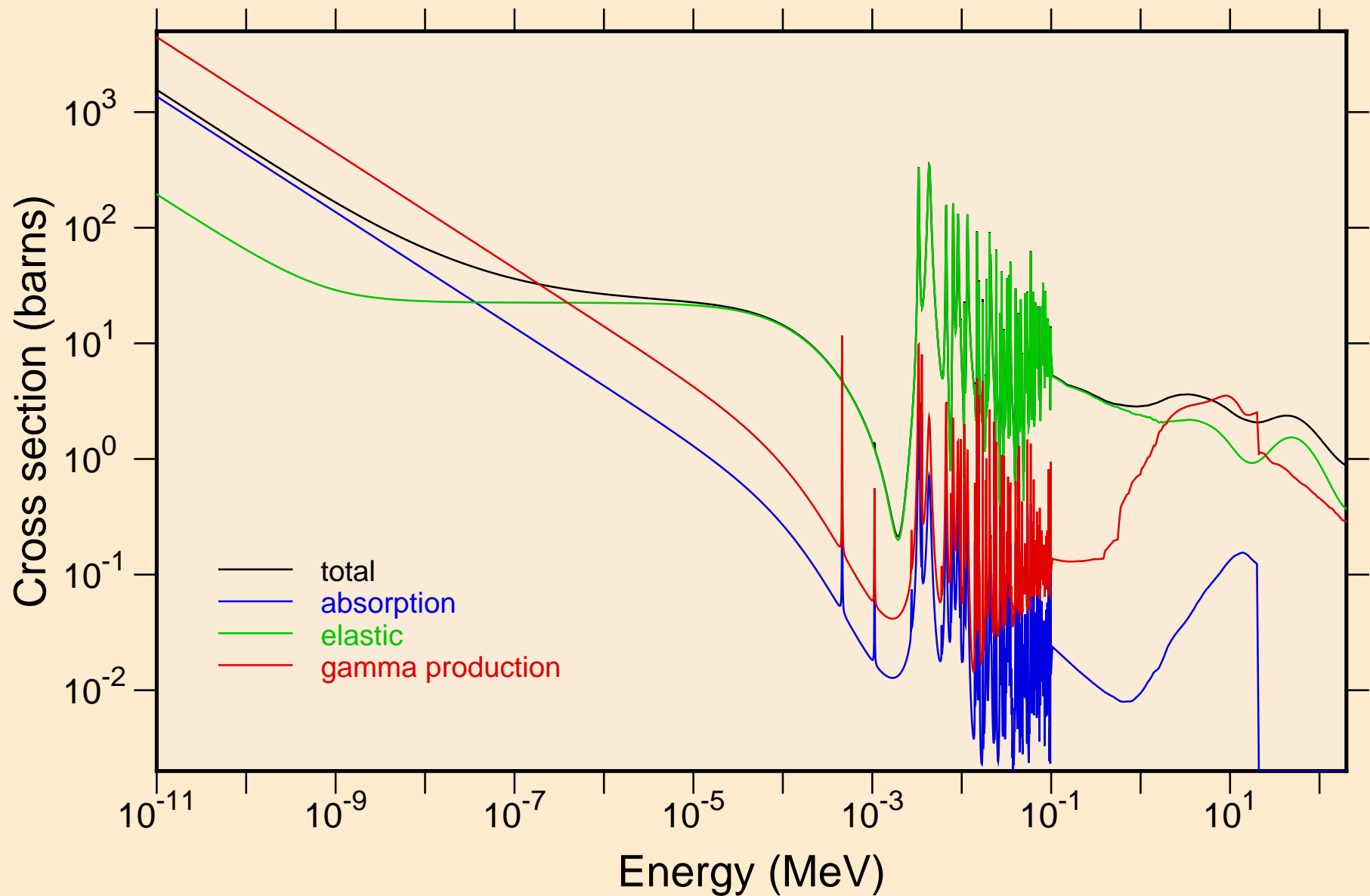

21-SC-45 FOR FENDL-3.1 FROM JEFF-3.1.1 WITH NJOY2012.50+  
resonance total cross section

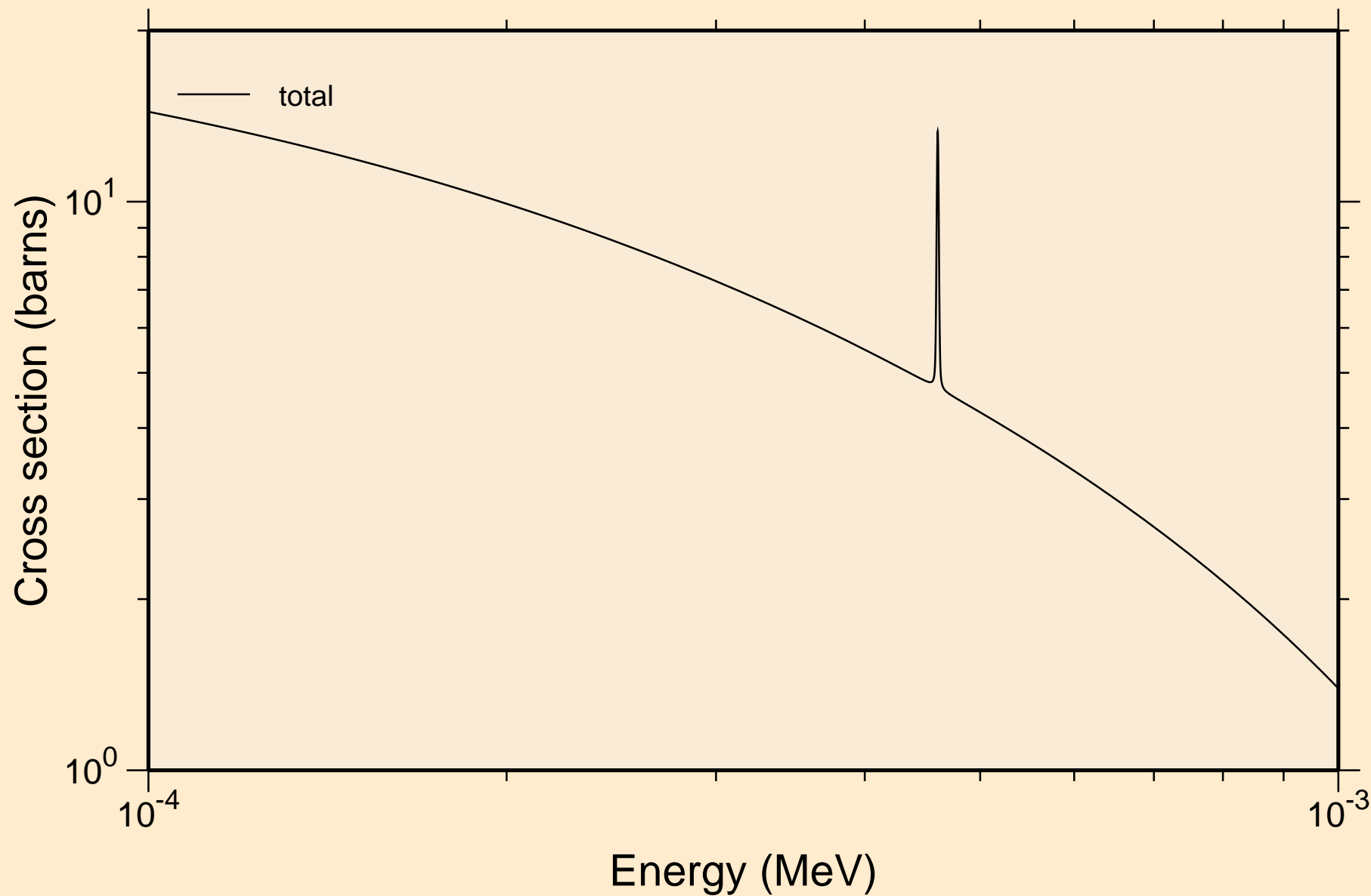

21-SC-45 FOR FENDL-3.1 FROM JEFF-3.1.1 WITH NJOY2012.50+  
resonance total cross section

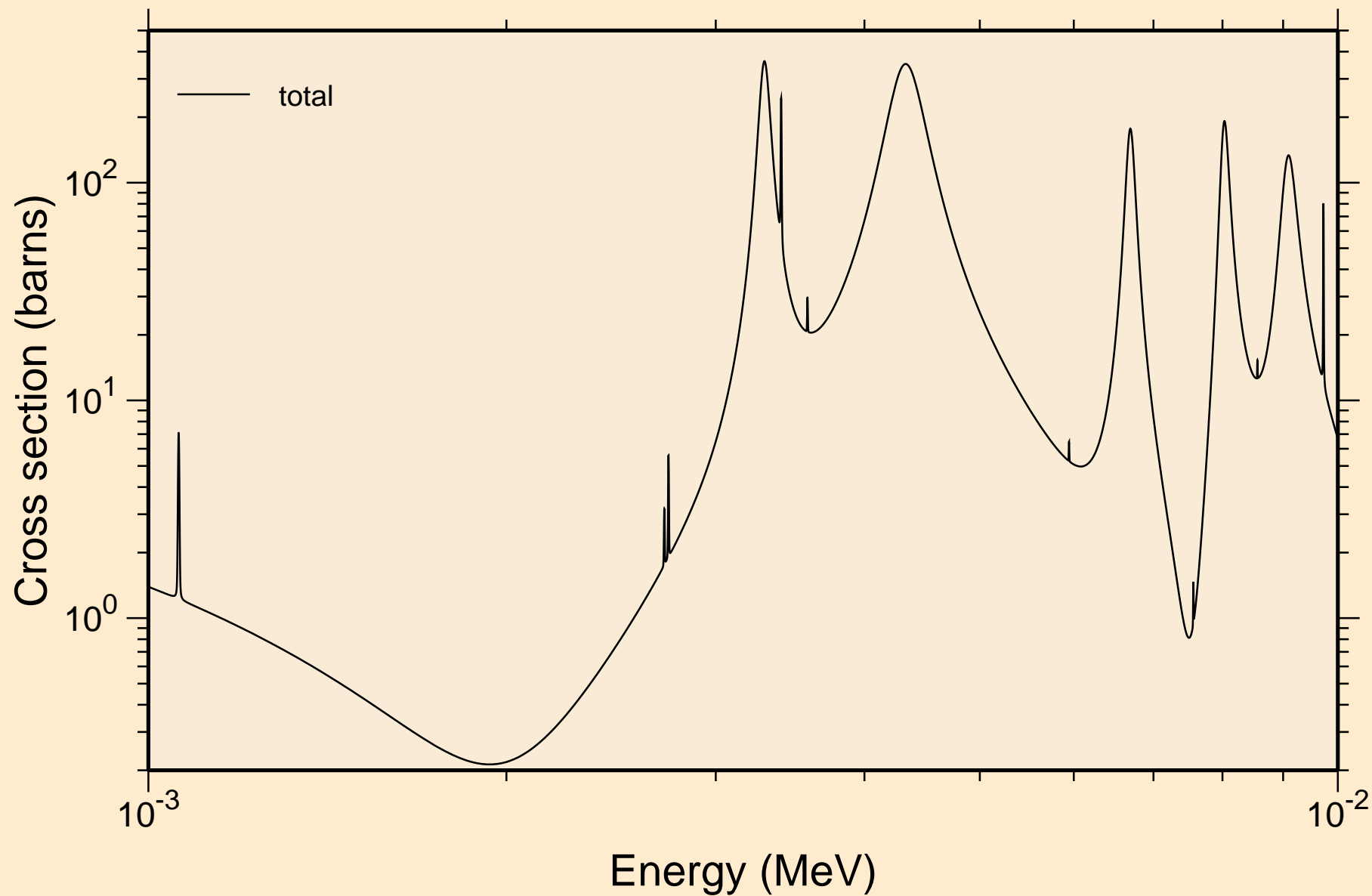

21-SC-45 FOR FENDL-3.1 FROM JEFF-3.1.1 WITH NJOY2012.50+  
resonance total cross section

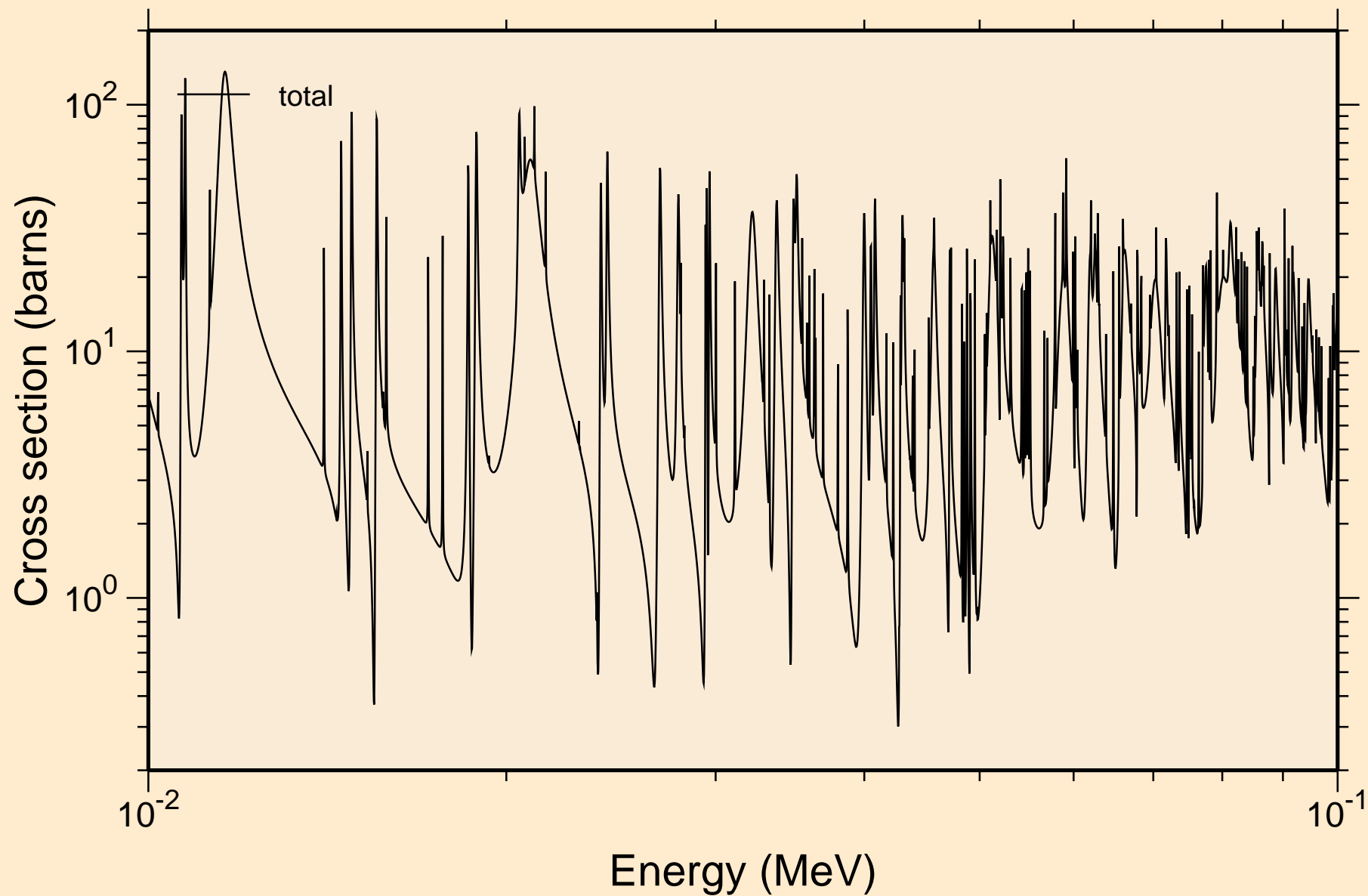

21-SC-45 FOR FENDL-3.1 FROM JEFF-3.1.1 WITH NJOY2012.50+  
resonance total cross section

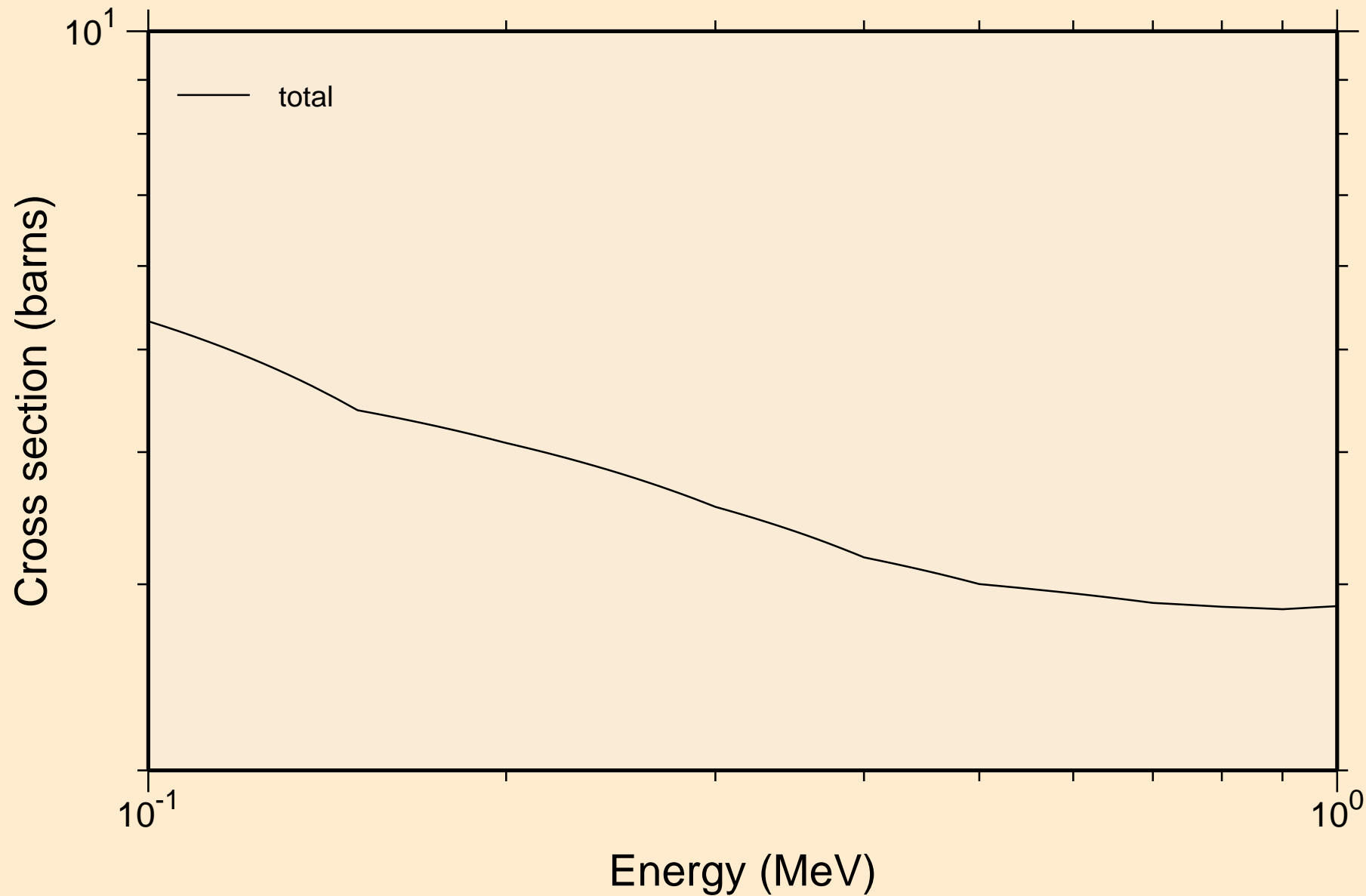

21-SC-45 FOR FENDL-3.1 FROM JEFF-3.1.1 WITH NJOY2012.50+  
resonance total cross section

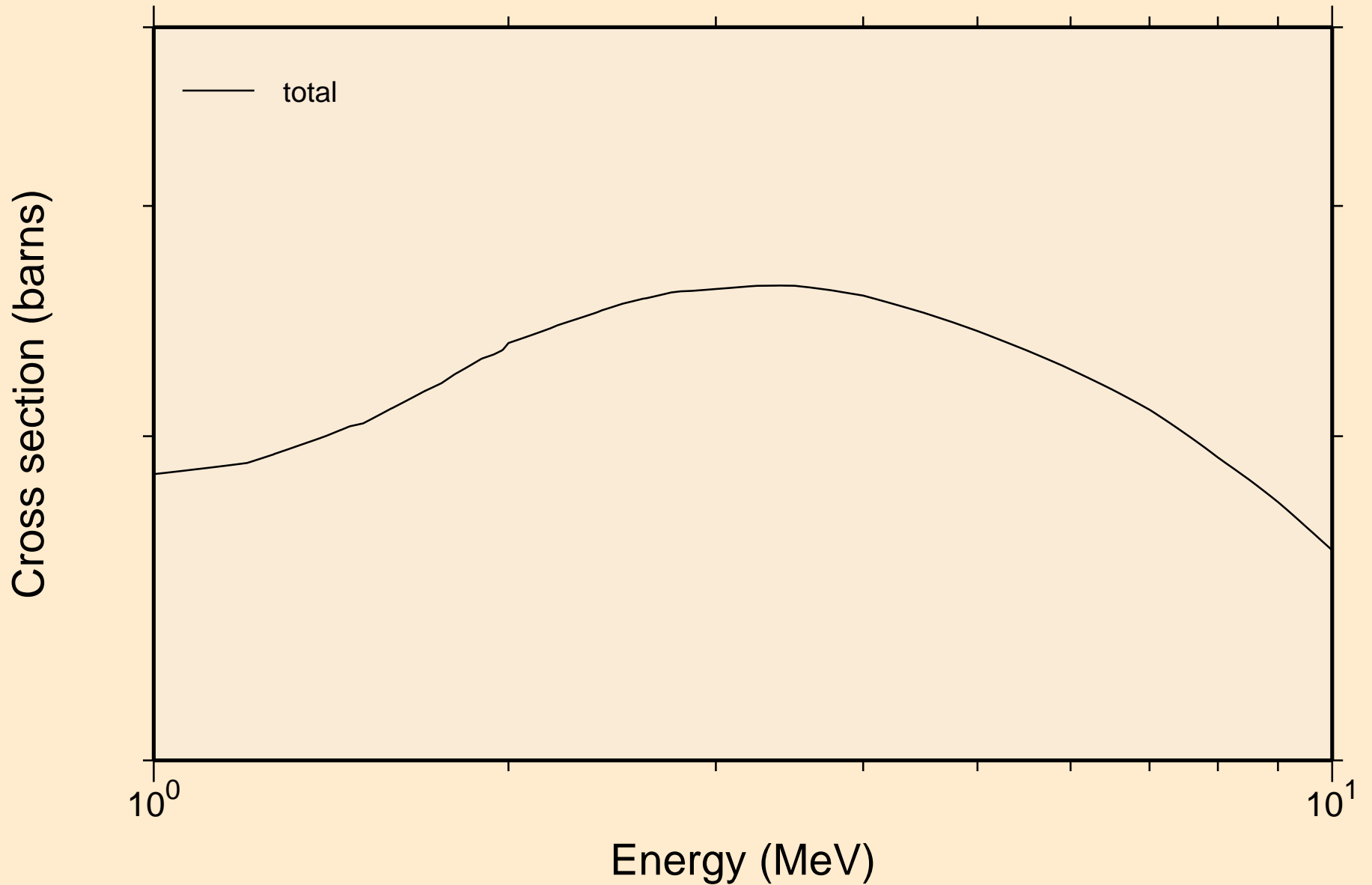

21-SC-45 FOR FENDL-3.1 FROM JEFF-3.1.1 WITH NJOY2012.50+  
resonance absorption cross sections

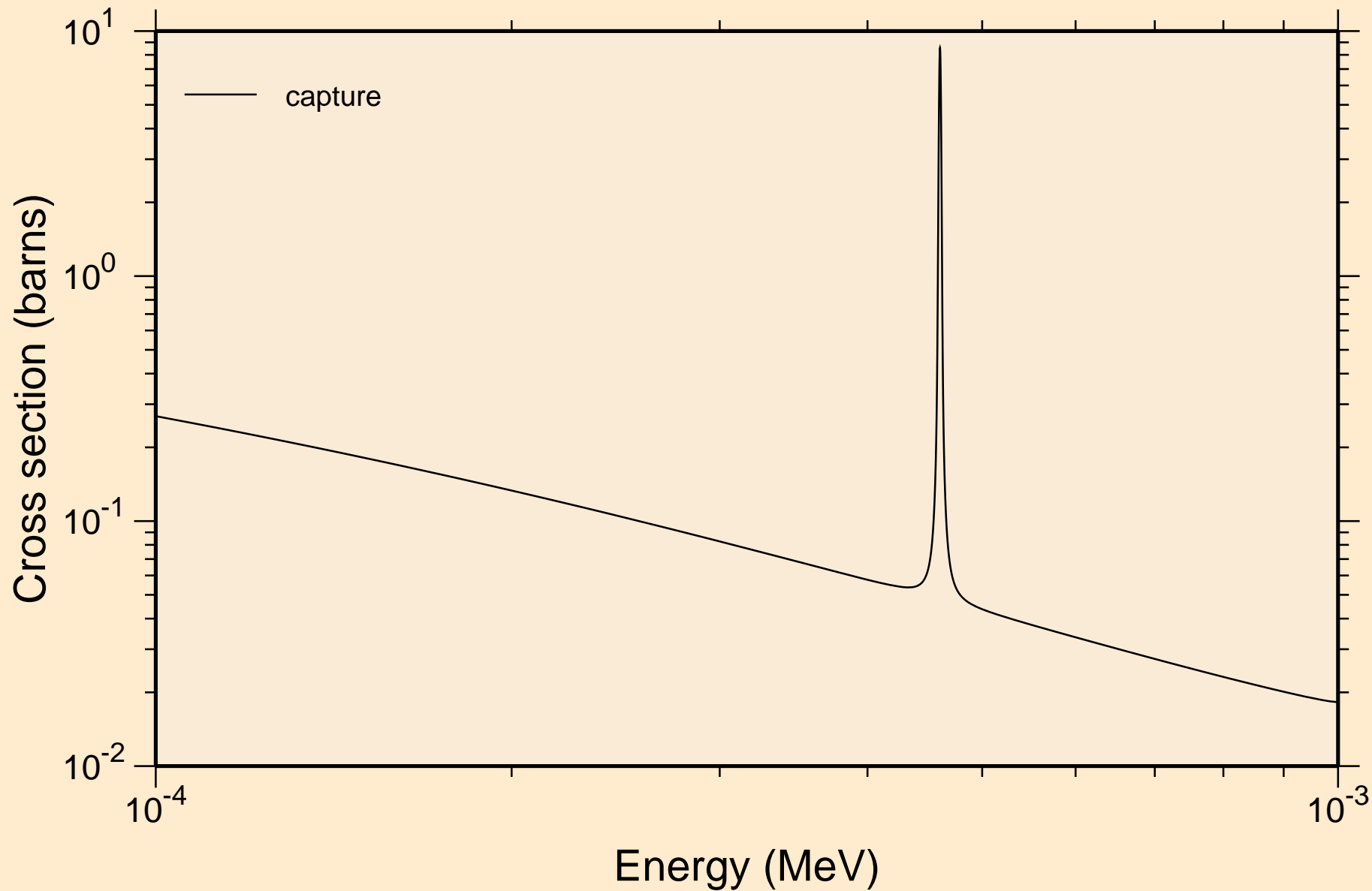

21-SC-45 FOR FENDL-3.1 FROM JEFF-3.1.1 WITH NJOY2012.50+  
resonance absorption cross sections

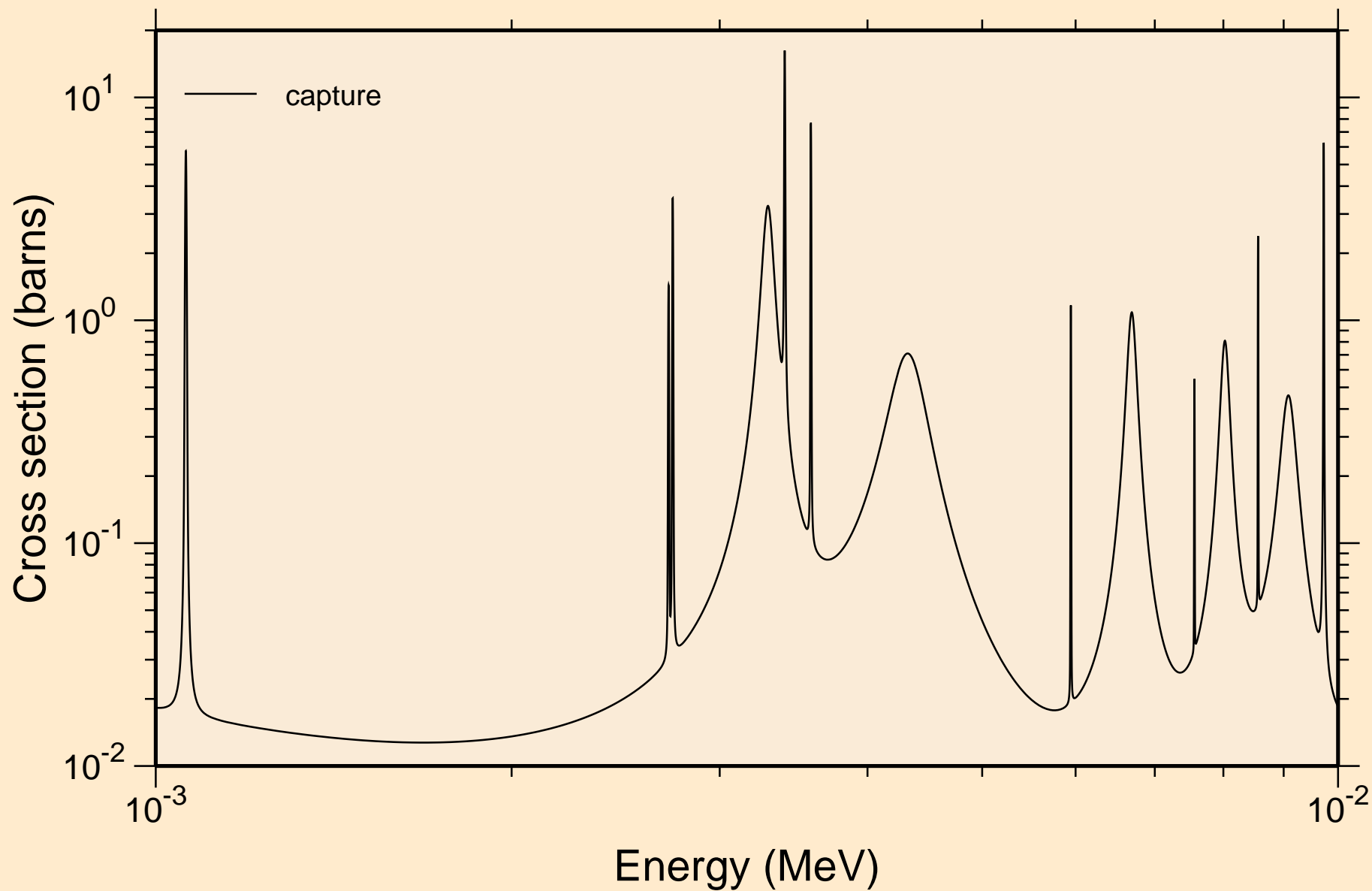



21-SC-45 FOR FENDL-3.1 FROM JEFF-3.1.1 WITH NJOY2012.50+  
resonance absorption cross sections

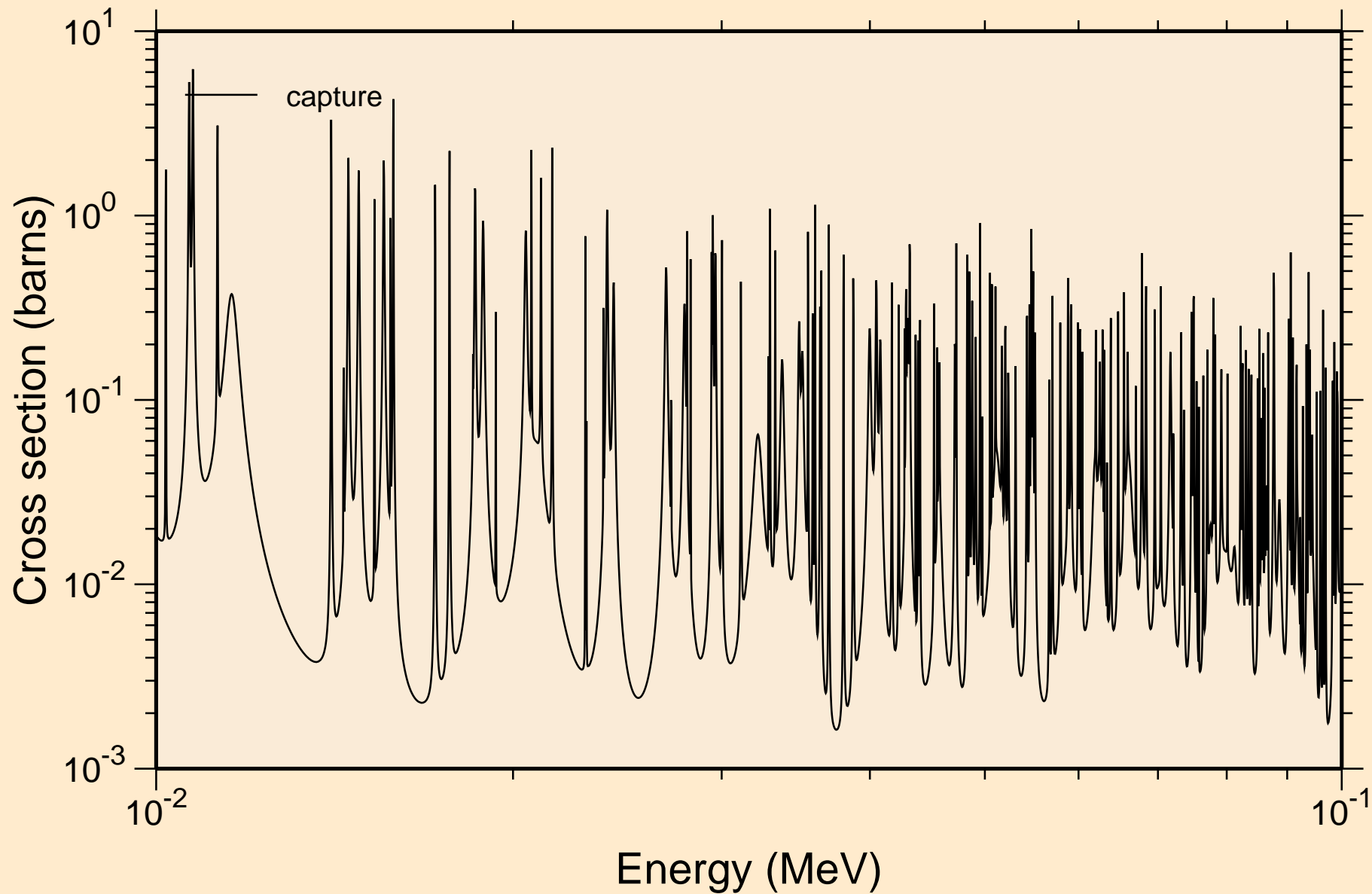

21-SC-45 FOR FENDL-3.1 FROM JEFF-3.1.1 WITH NJOY2012.50+  
resonance absorption cross sections

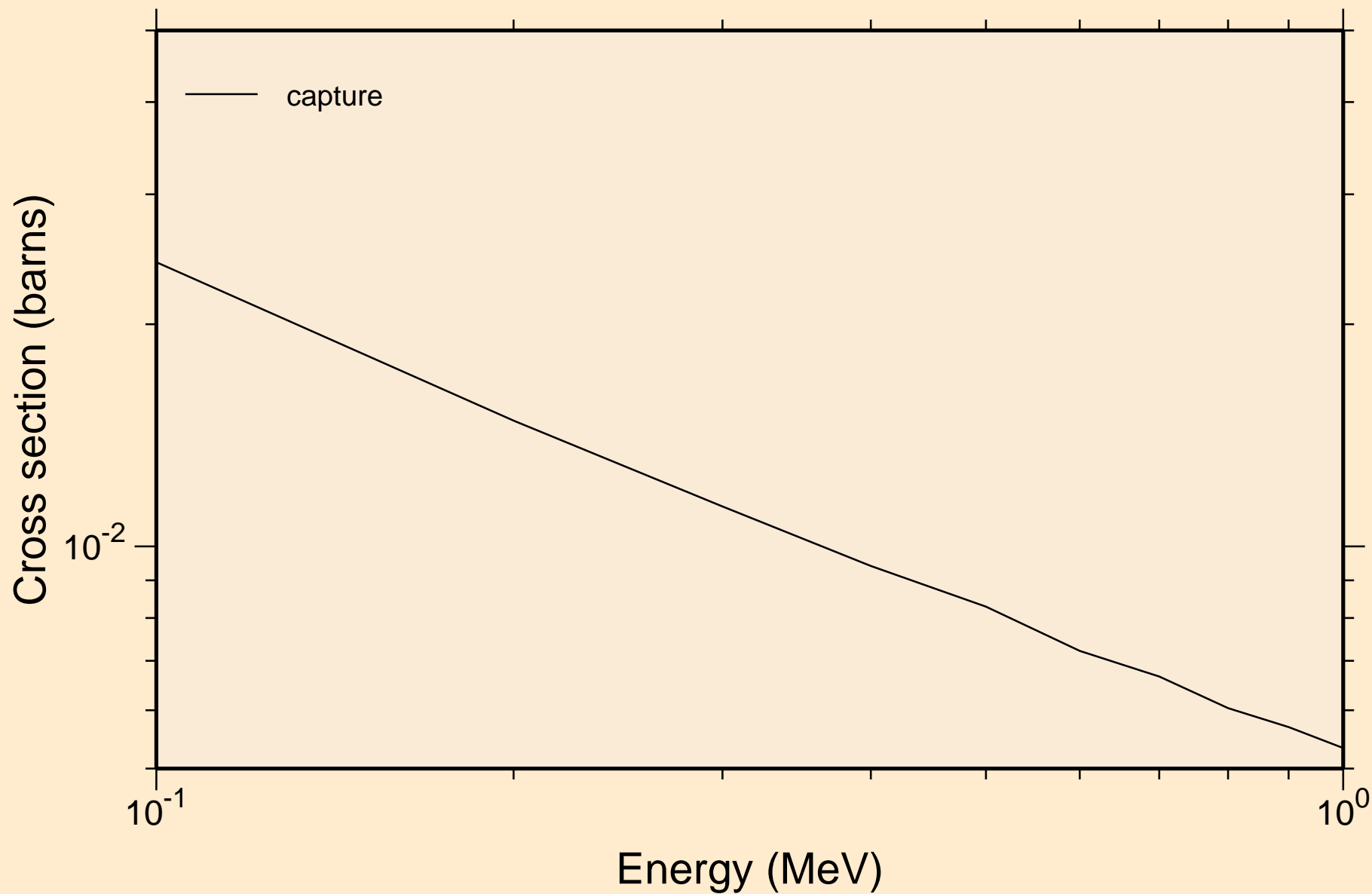

21-SC-45 FOR FENDL-3.1 FROM JEFF-3.1.1 WITH NJOY2012.50+  
resonance absorption cross sections

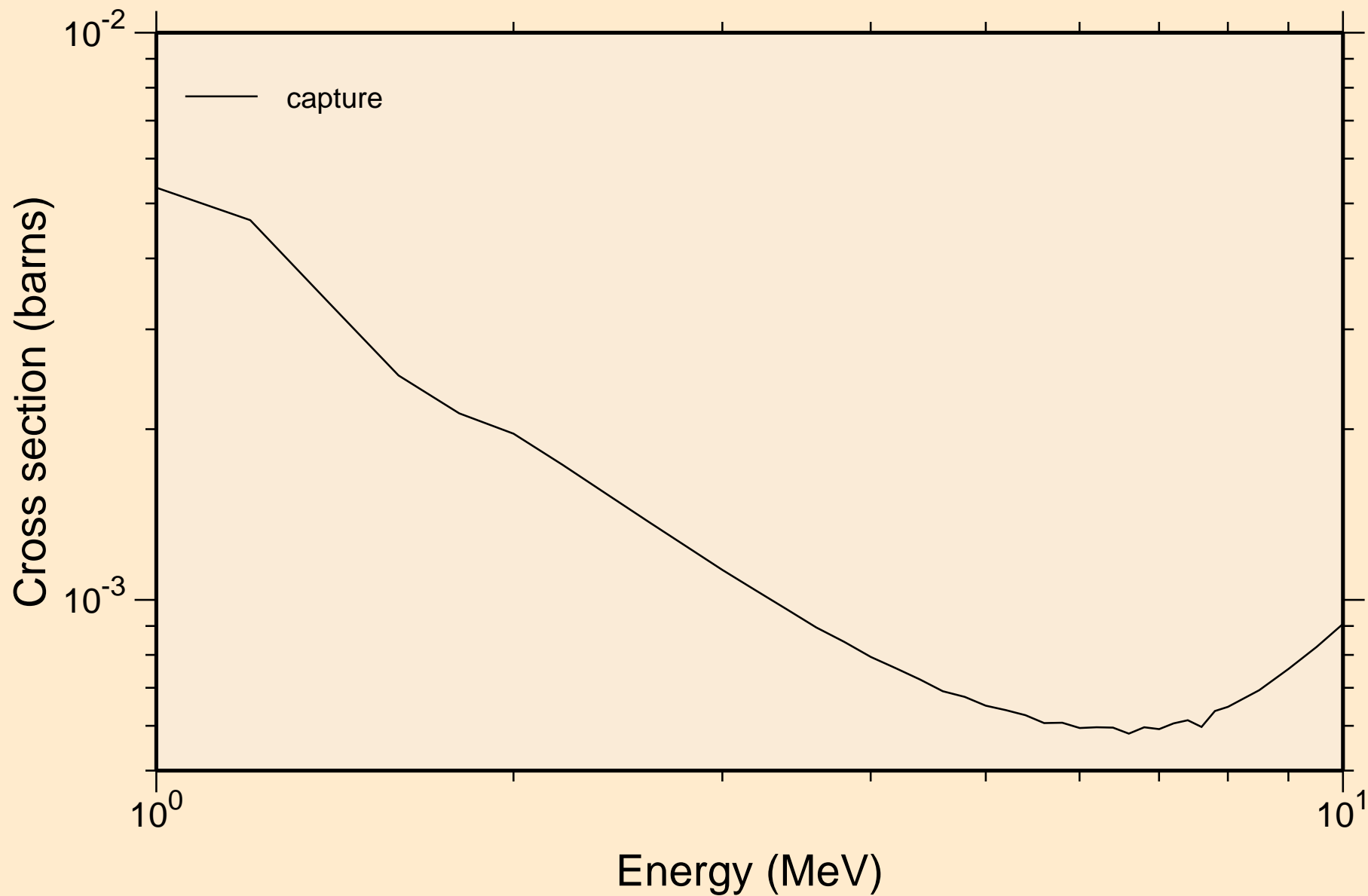

# 21-SC-45 FOR FENDL-3.1 FROM JEFF-3.1.1 WITH NJOY2012.50+ Heating

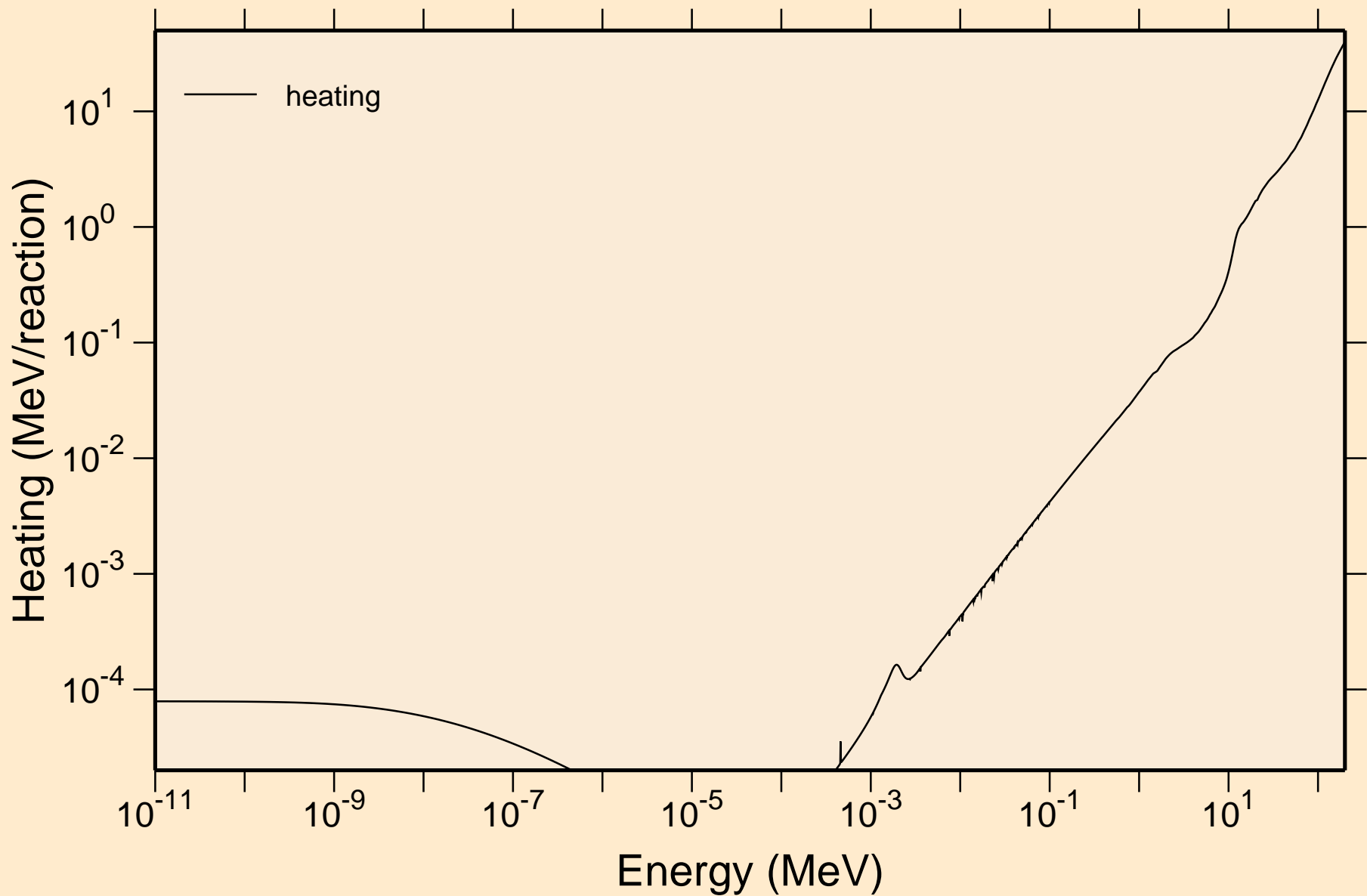

# 21-SC-45 FOR FENDL-3.1 FROM JEFF-3.1.1 WITH NJOY2012.50+ Damage

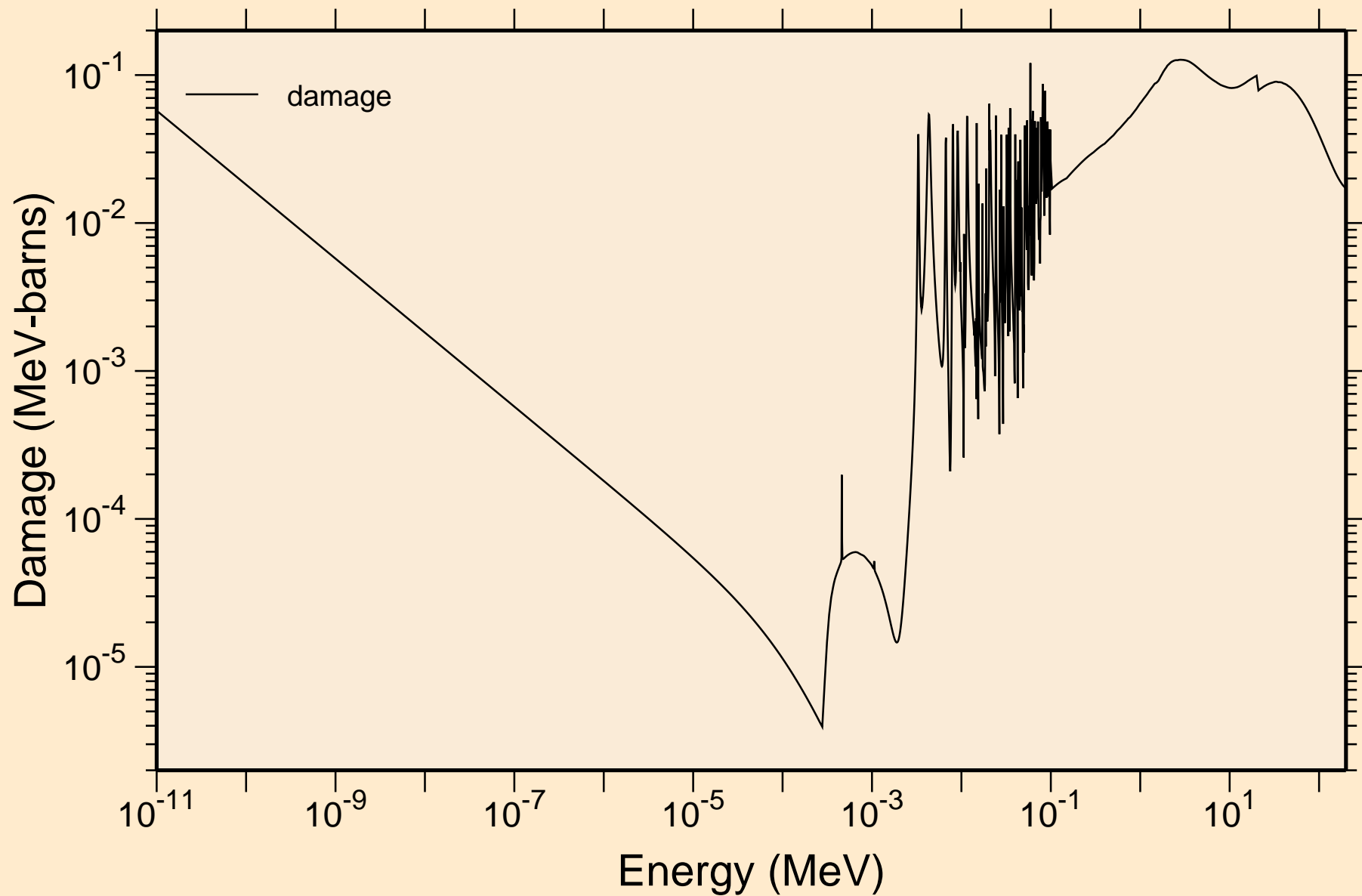

21-SC-45 FOR FENDL-3.1 FROM JEFF-3.1.1 WITH NJOY2012.50+  
Non-threshold reactions

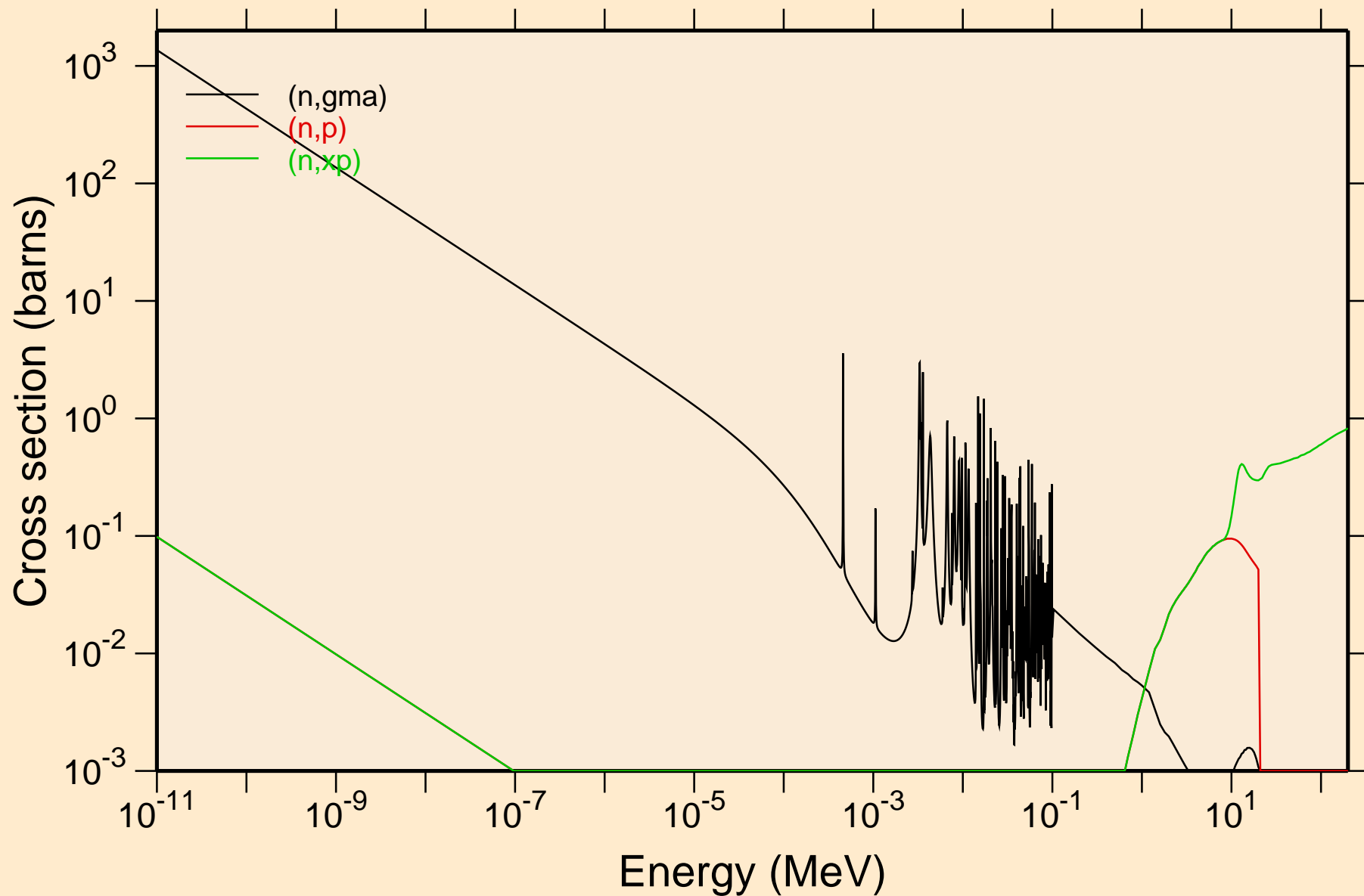

# 21-SC-45 FOR FENDL-3.1 FROM JEFF-3.1.1 WITH NJOY2012.50+

## Principal cross sections

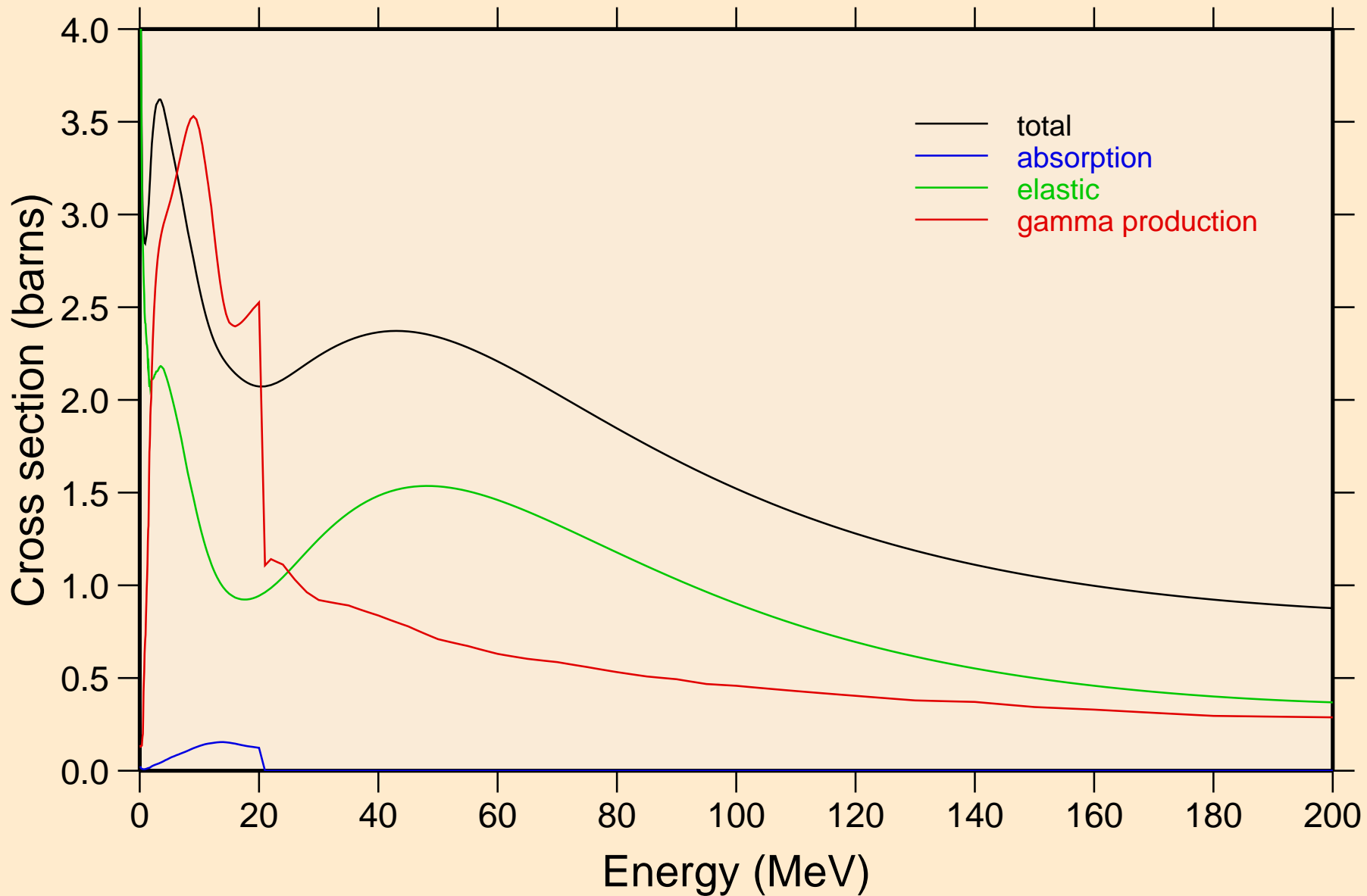

# 21-SC-45 FOR FENDL-3.1 FROM JEFF-3.1.1 WITH NJOY2012.50+ Heating

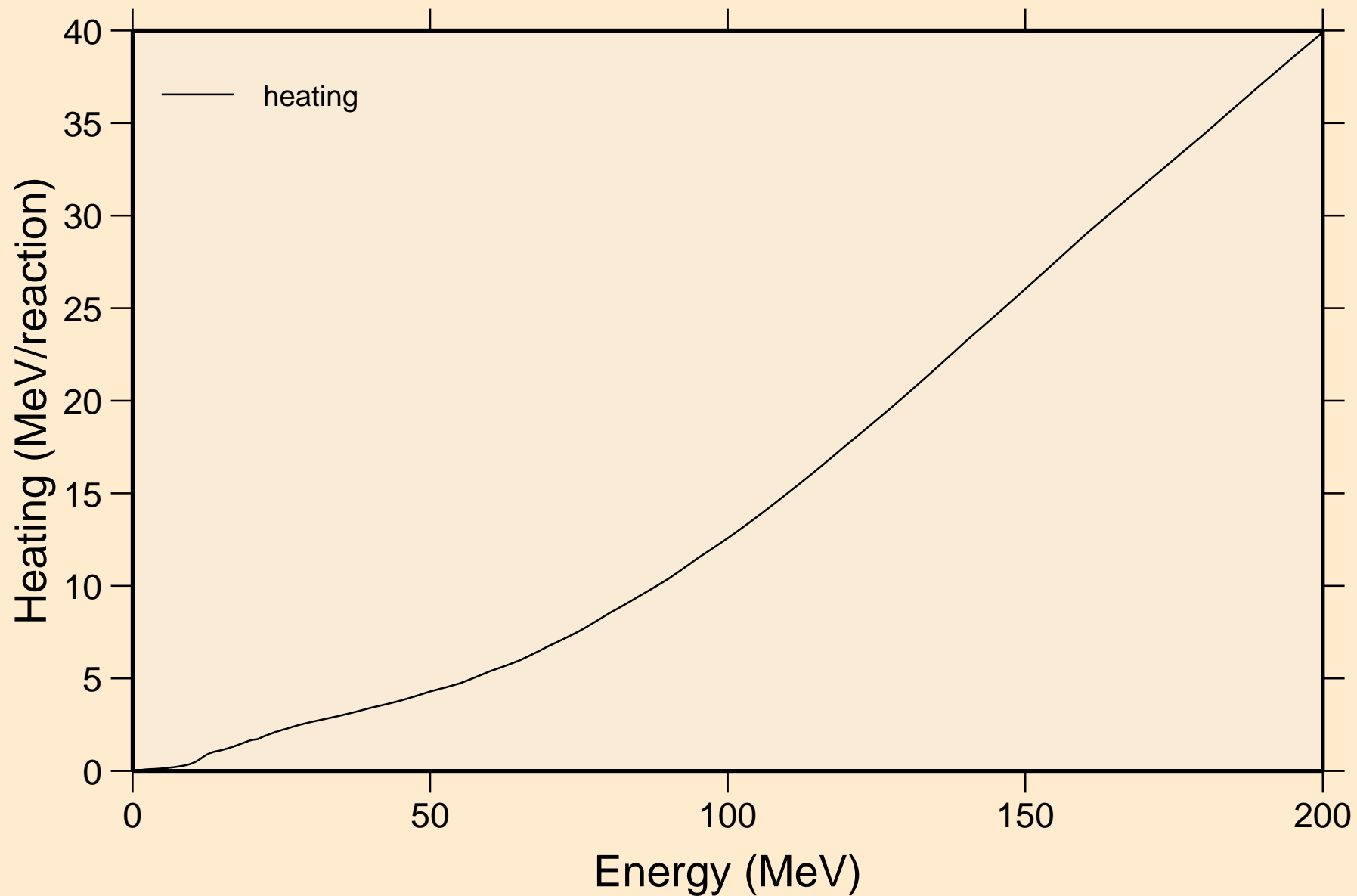



# 21-SC-45 FOR FENDL-3.1 FROM JEFF-3.1.1 WITH NJOY2012.50+ Damage

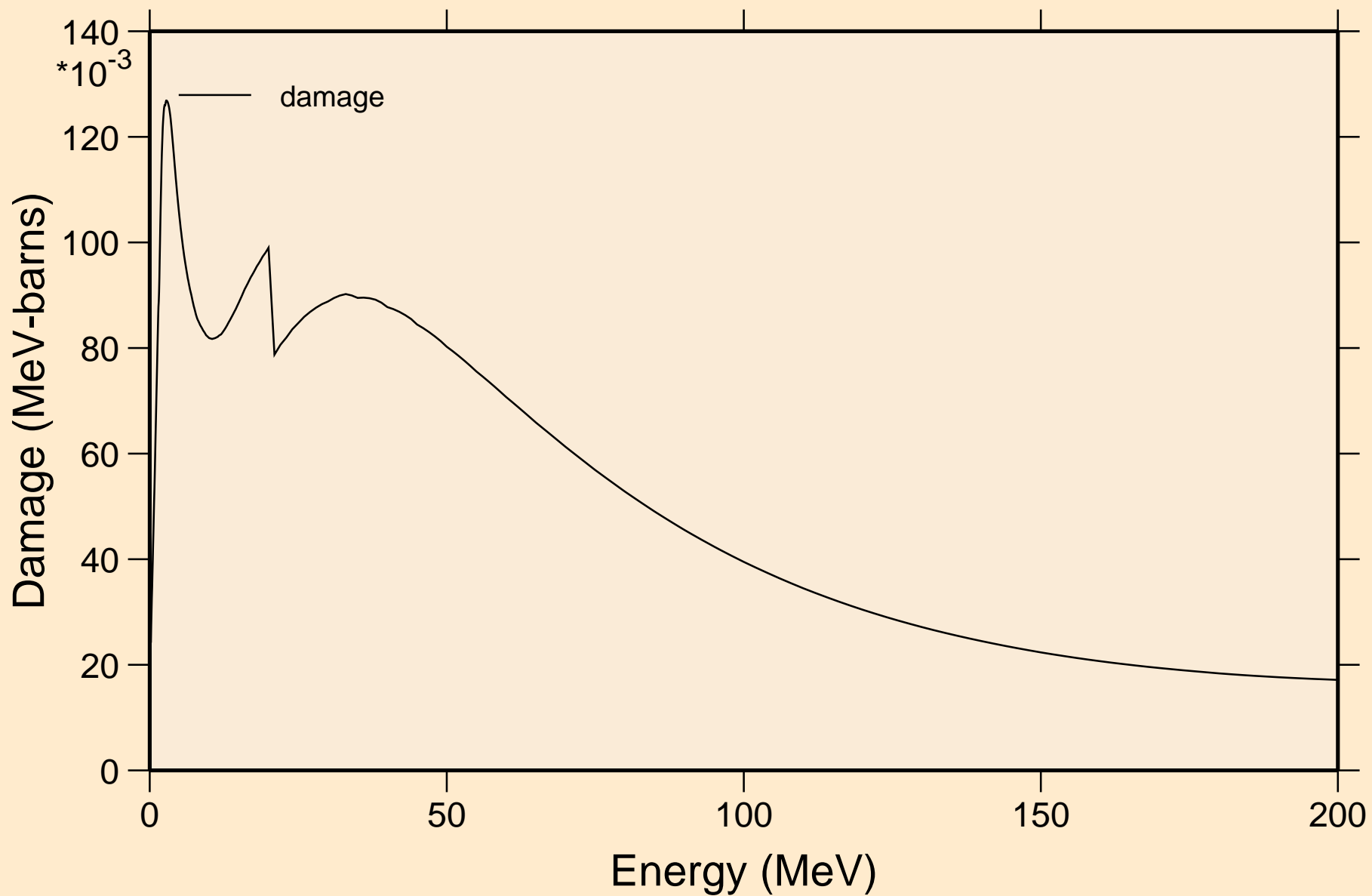

# 21-SC-45 FOR FENDL-3.1 FROM JEFF-3.1.1 WITH NJOY2012.50+

## Non-threshold reactions

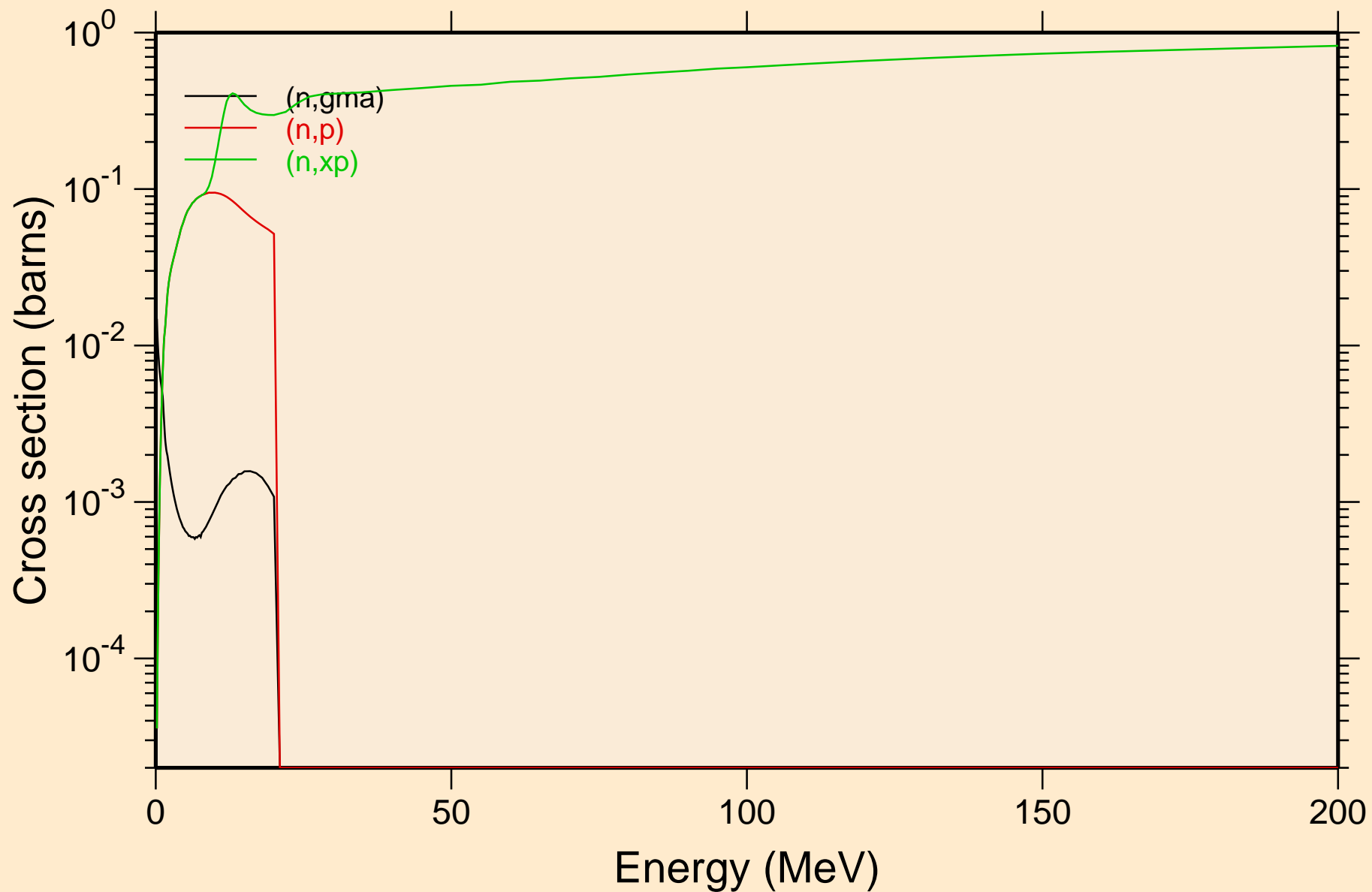

# 21-SC-45 FOR FENDL-3.1 FROM JEFF-3.1.1 WITH NJOY2012.50+ Inelastic levels

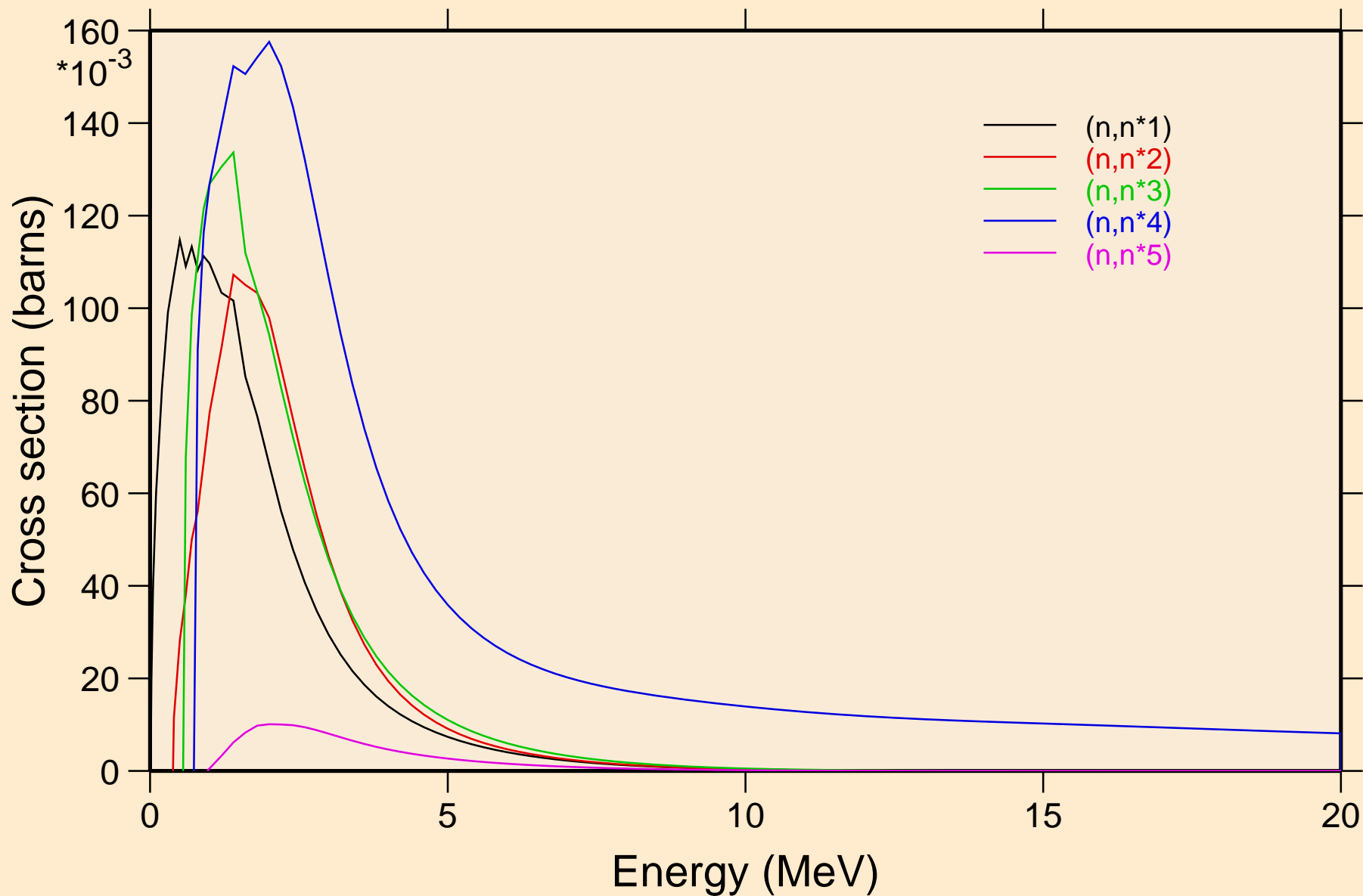

# 21-SC-45 FOR FENDL-3.1 FROM JEFF-3.1.1 WITH NJOY2012.50+ Inelastic levels

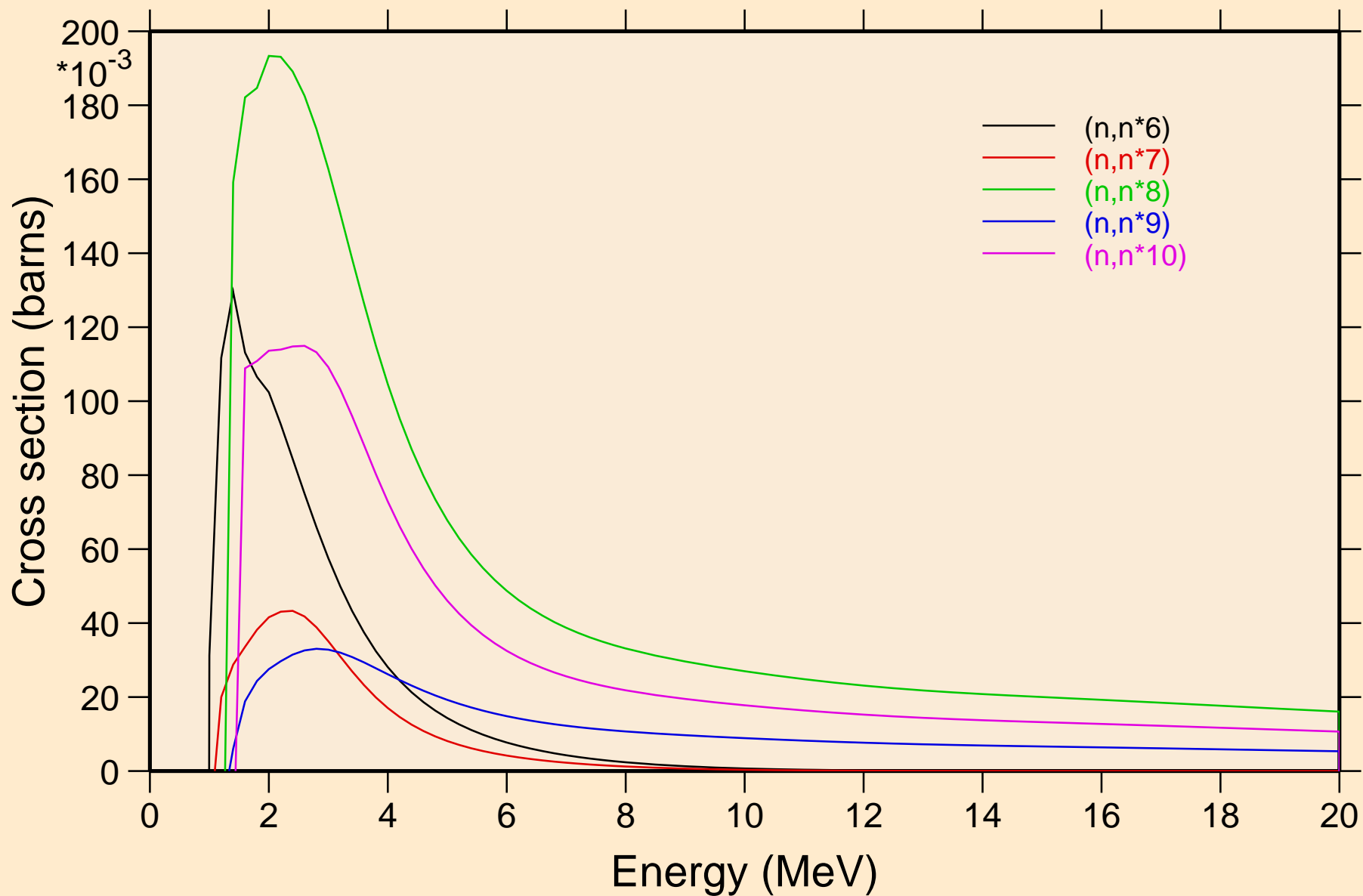

# 21-SC-45 FOR FENDL-3.1 FROM JEFF-3.1.1 WITH NJOY2012.50+ Inelastic levels

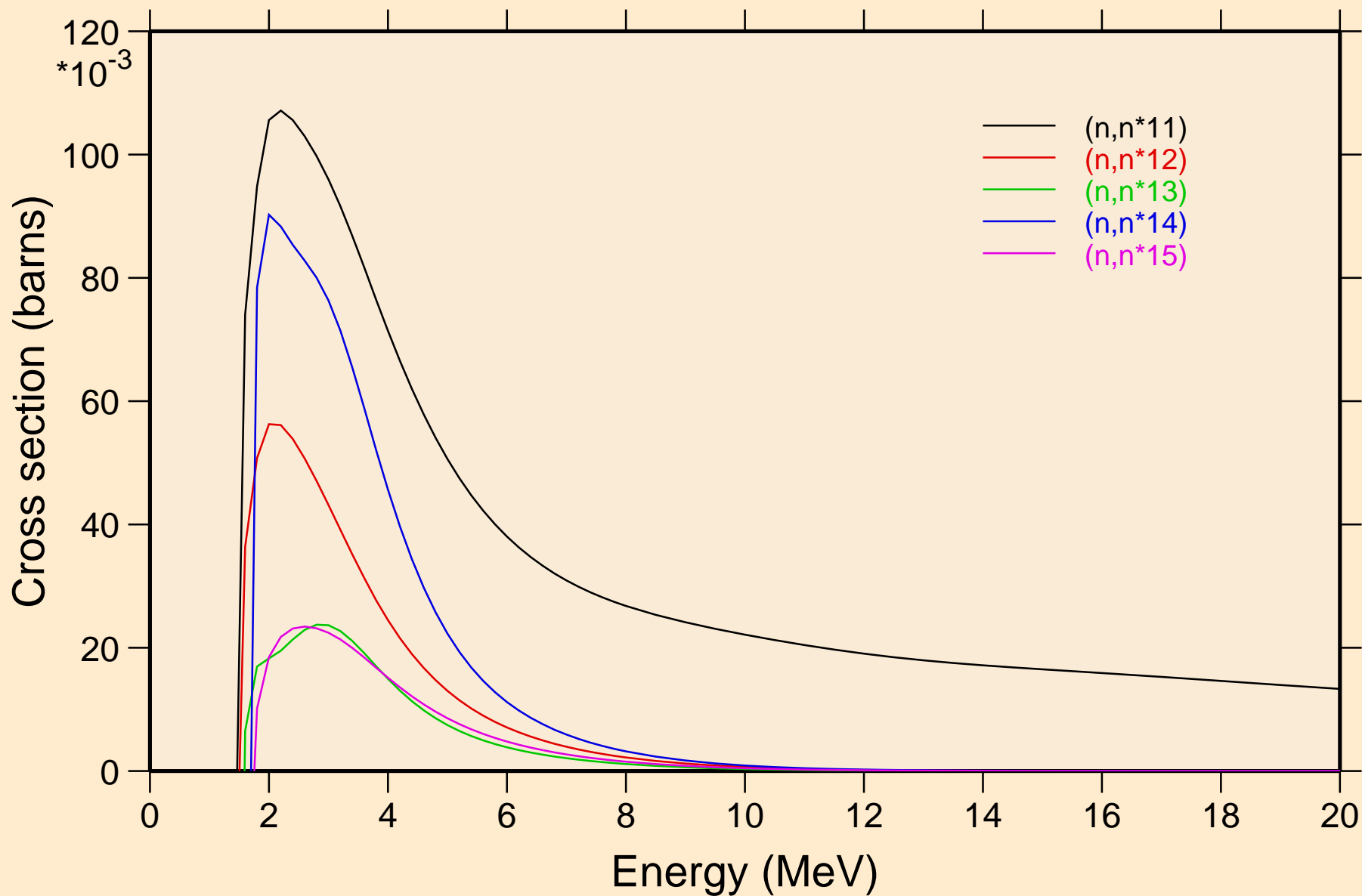

# 21-SC-45 FOR FENDL-3.1 FROM JEFF-3.1.1 WITH NJOY2012.50+ Inelastic levels

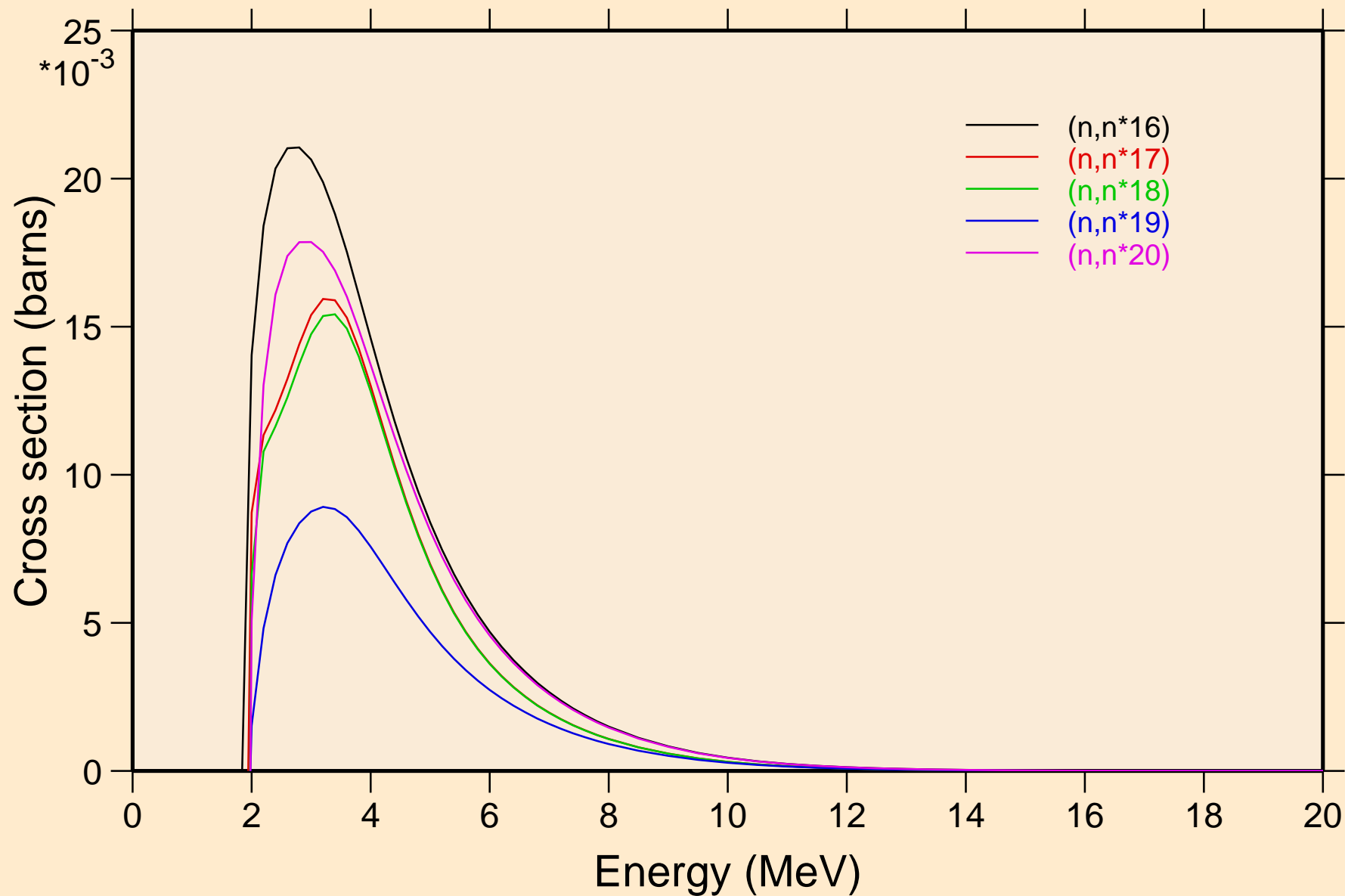

# 21-SC-45 FOR FENDL-3.1 FROM JEFF-3.1.1 WITH NJOY2012.50+

## Threshold reactions

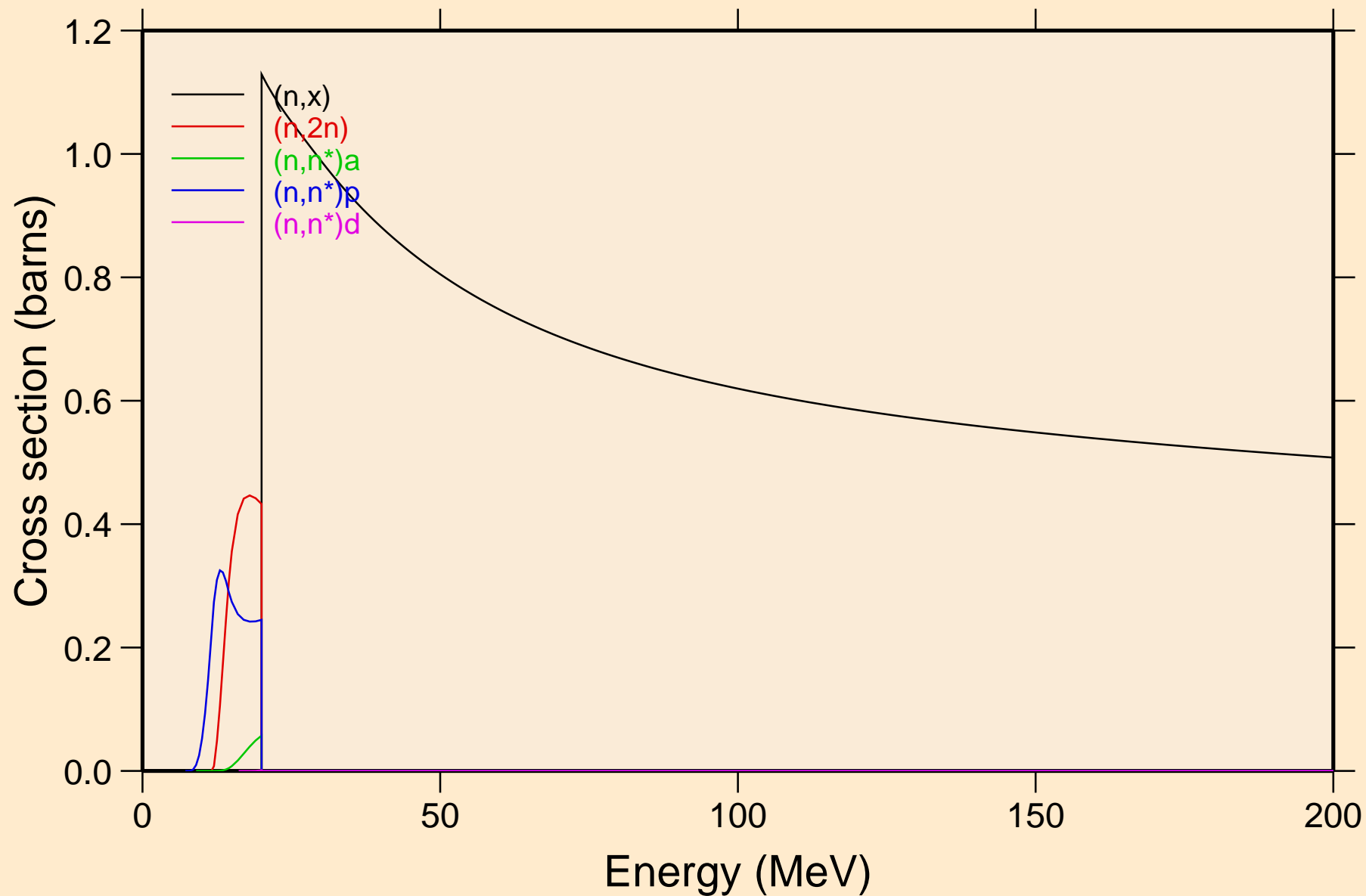

# 21-SC-45 FOR FENDL-3.1 FROM JEFF-3.1.1 WITH NJOY2012.50+

## Threshold reactions

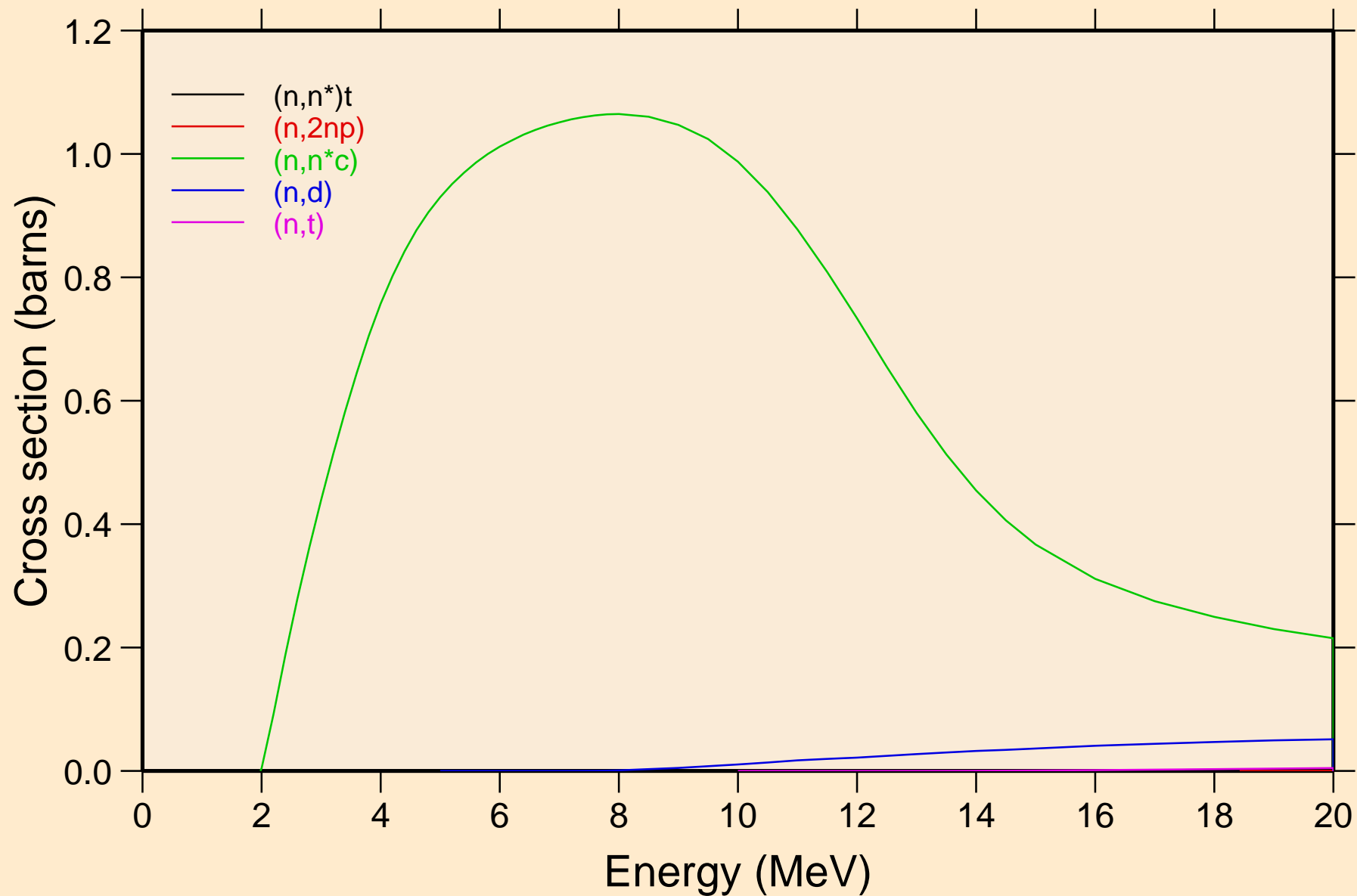



# 21-SC-45 FOR FENDL-3.1 FROM JEFF-3.1.1 WITH NJOY2012.50+

## Threshold reactions

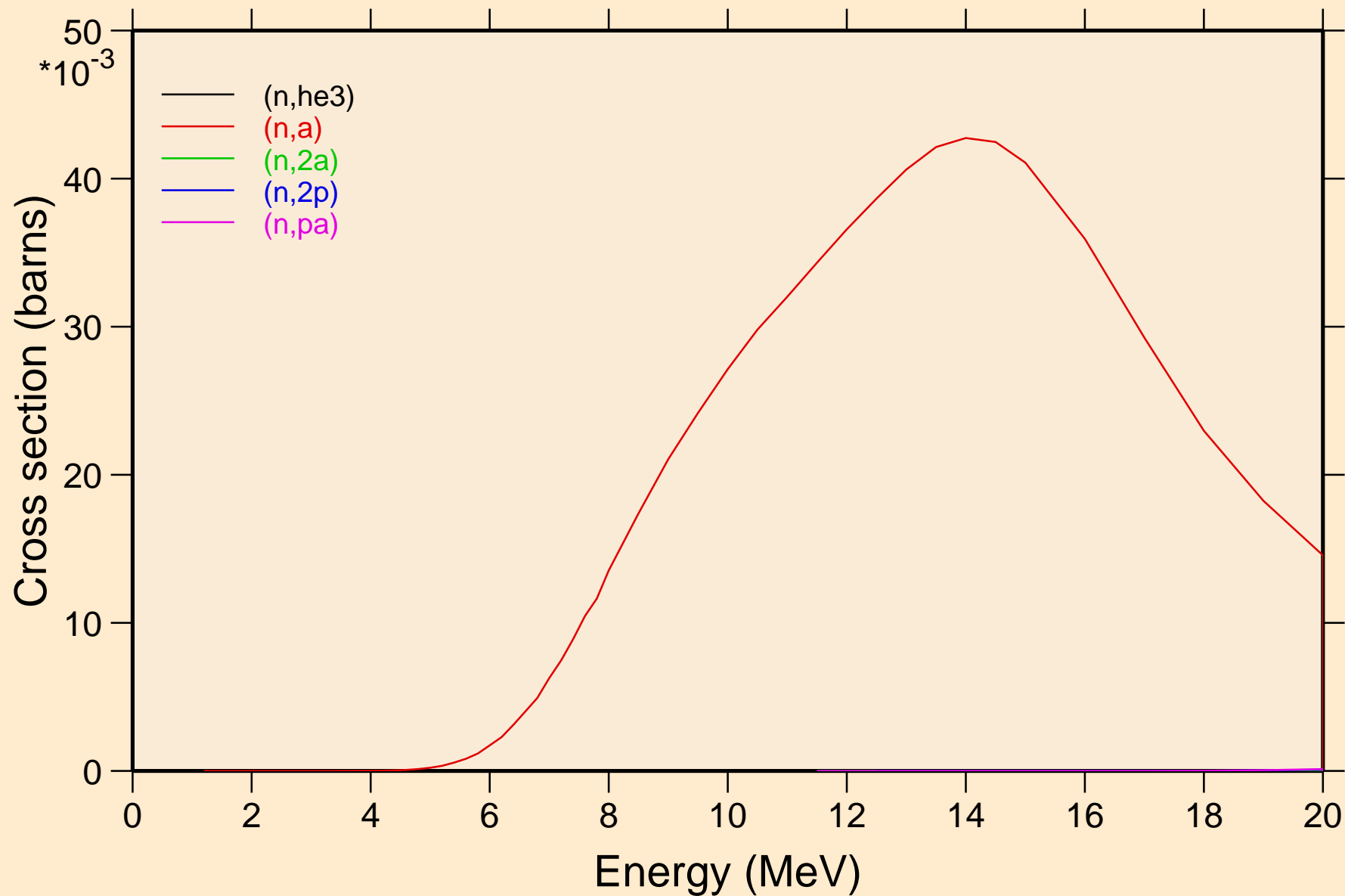

21-SC-45 FOR FENDL-3.1 FROM JEFF-3.1.1 WITH NJOY2012.50+  
Threshold reactions

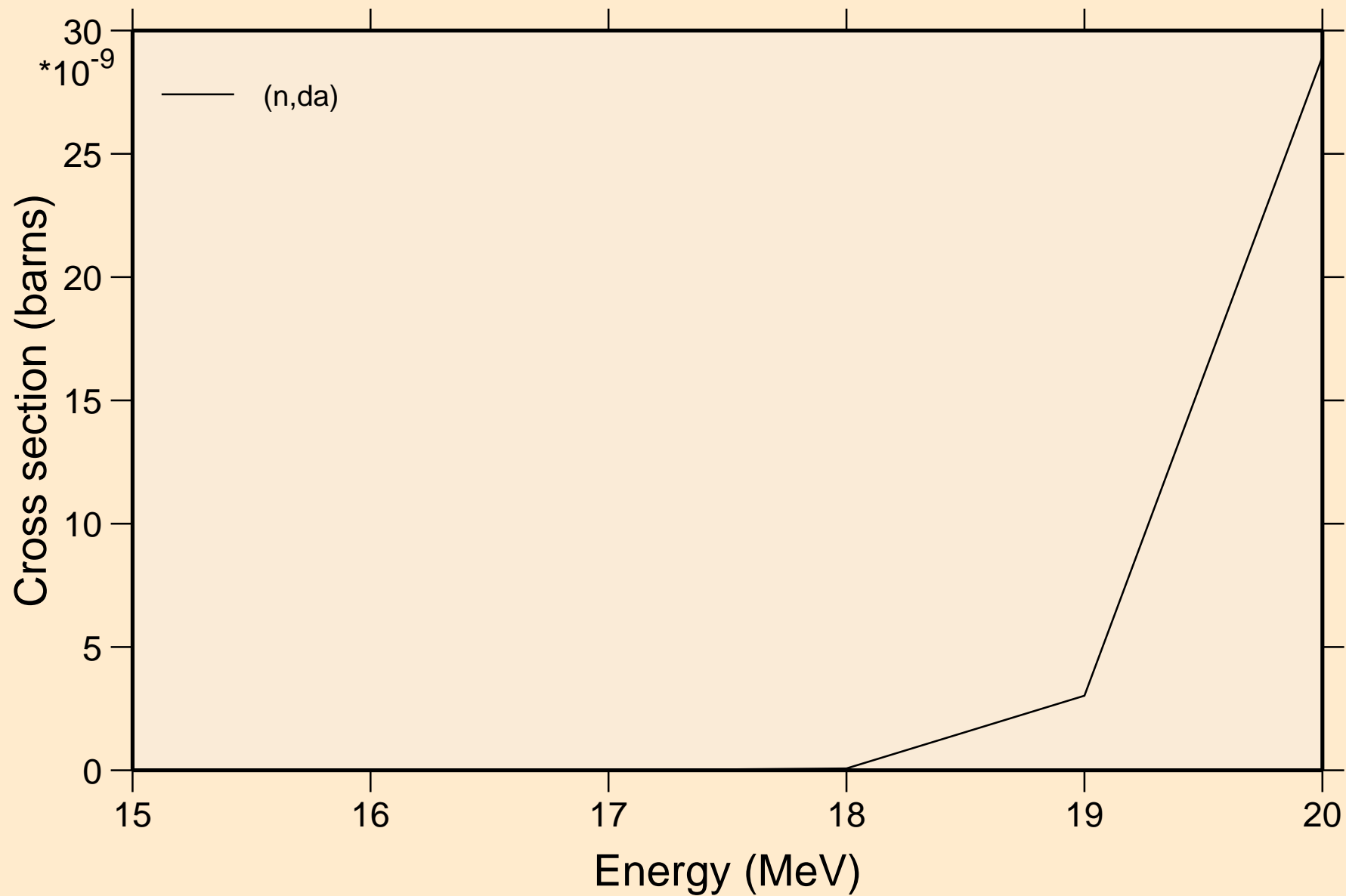

# 21-SC-45 FOR FENDL-3.1 FROM JEFF-3.1.1 WITH NJOY2012.50+

## Threshold reactions

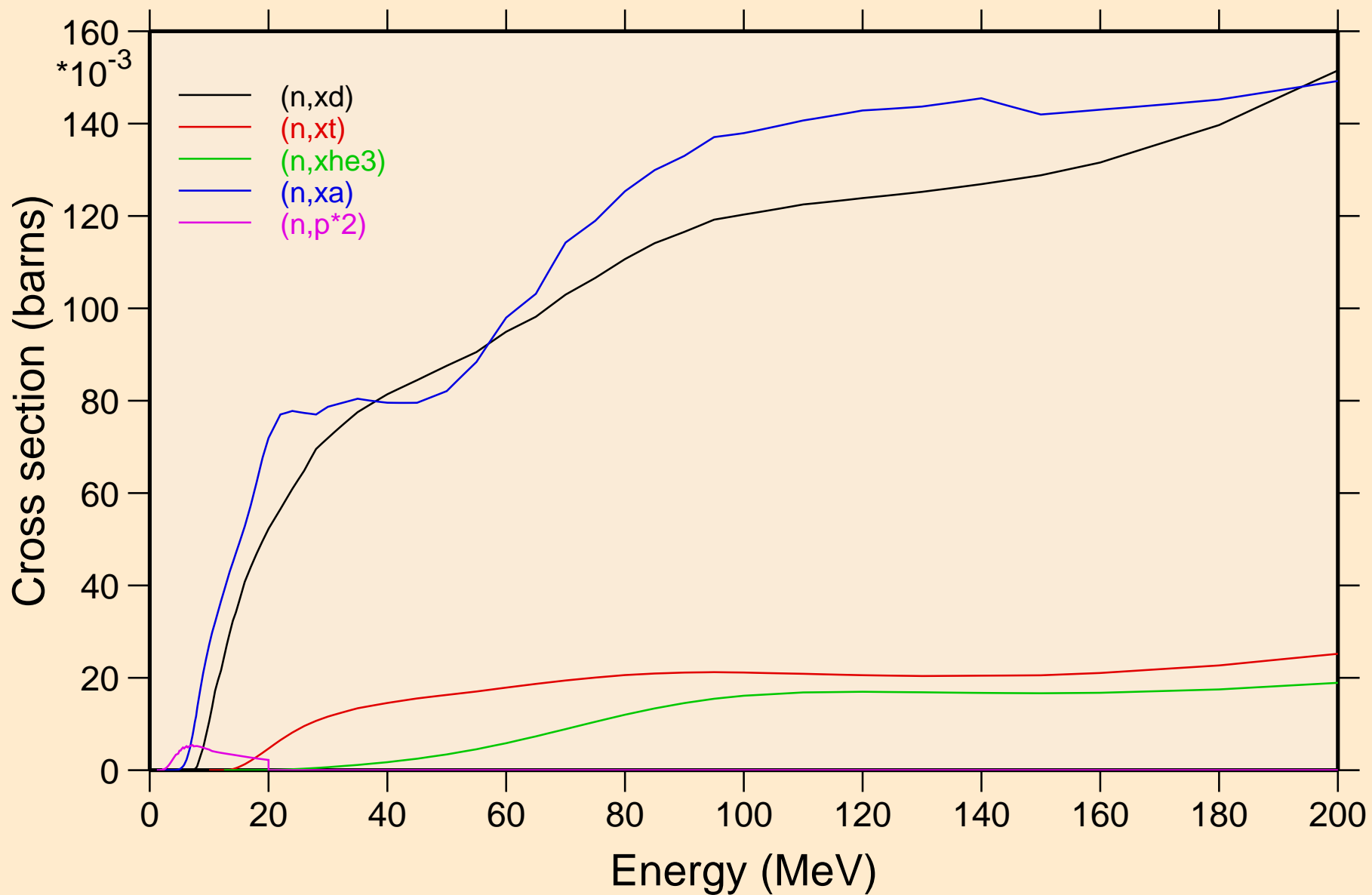

21-SC-45 FOR FENDL-3.1 FROM JEFF-3.1.1 WITH NJOY2012.50+  
Threshold reactions

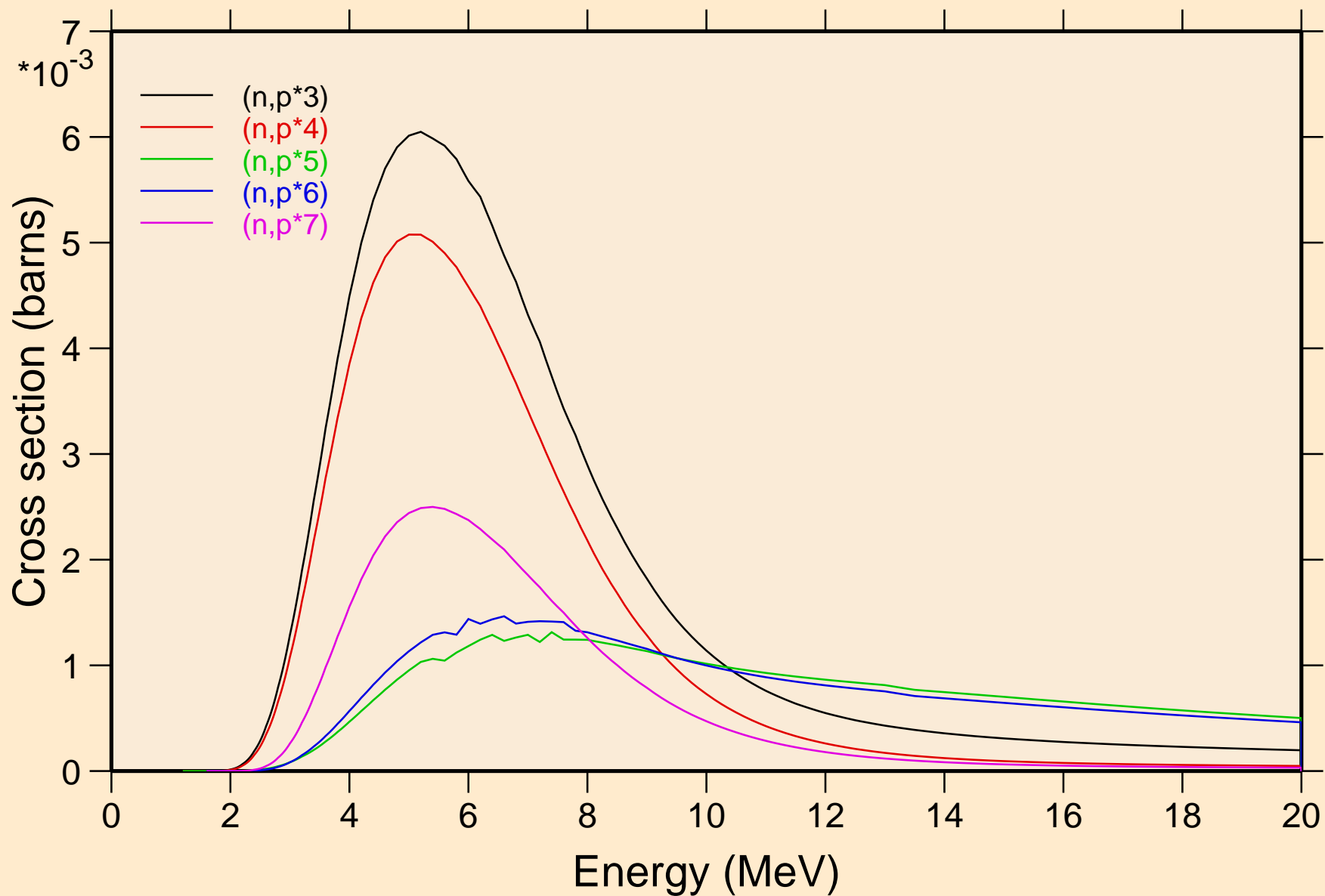

# 21-SC-45 FOR FENDL-3.1 FROM JEFF-3.1.1 WITH NJOY2012.50+

## Threshold reactions

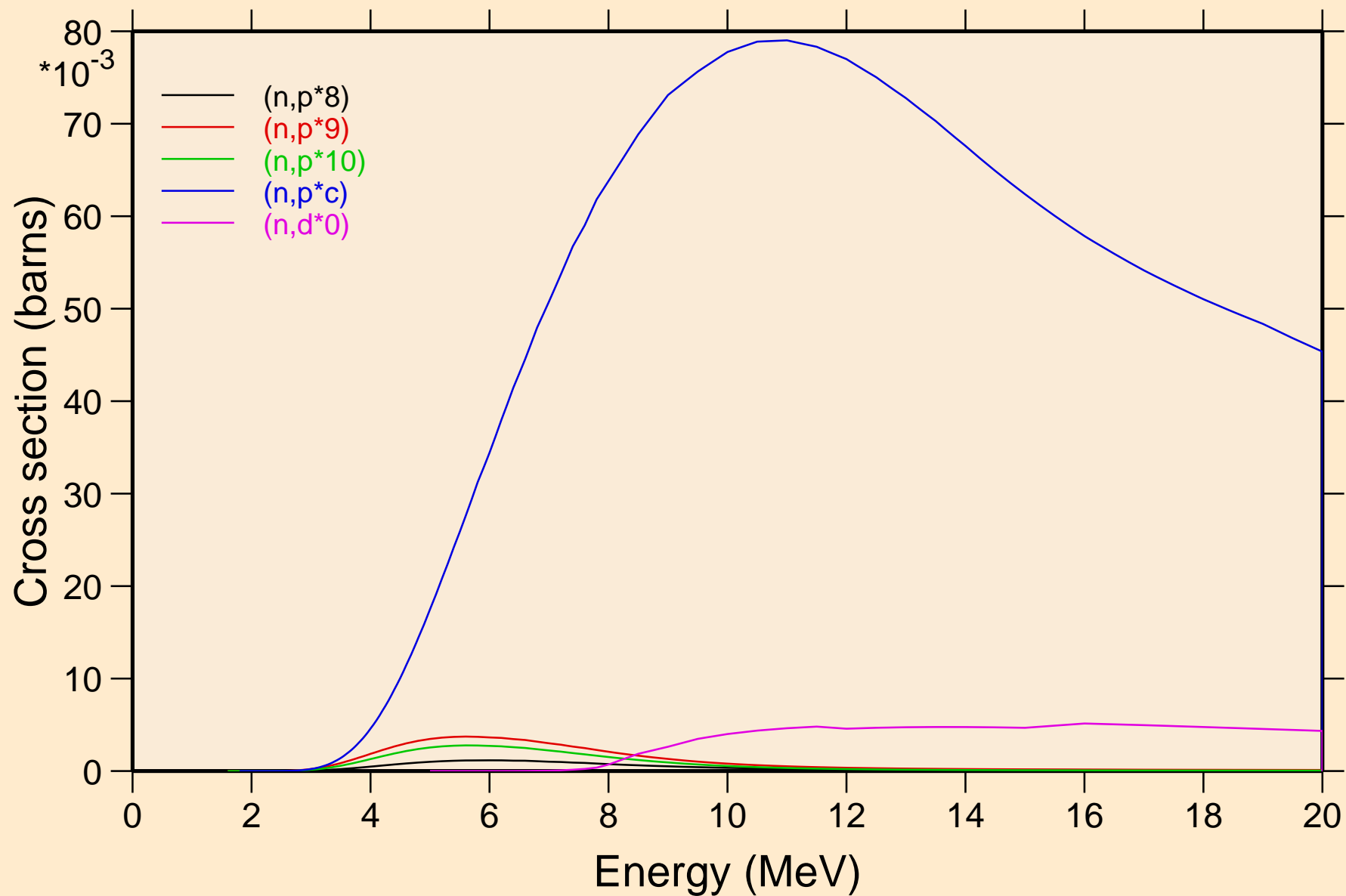

# 21-SC-45 FOR FENDL-3.1 FROM JEFF-3.1.1 WITH NJOY2012.50+ Threshold reactions

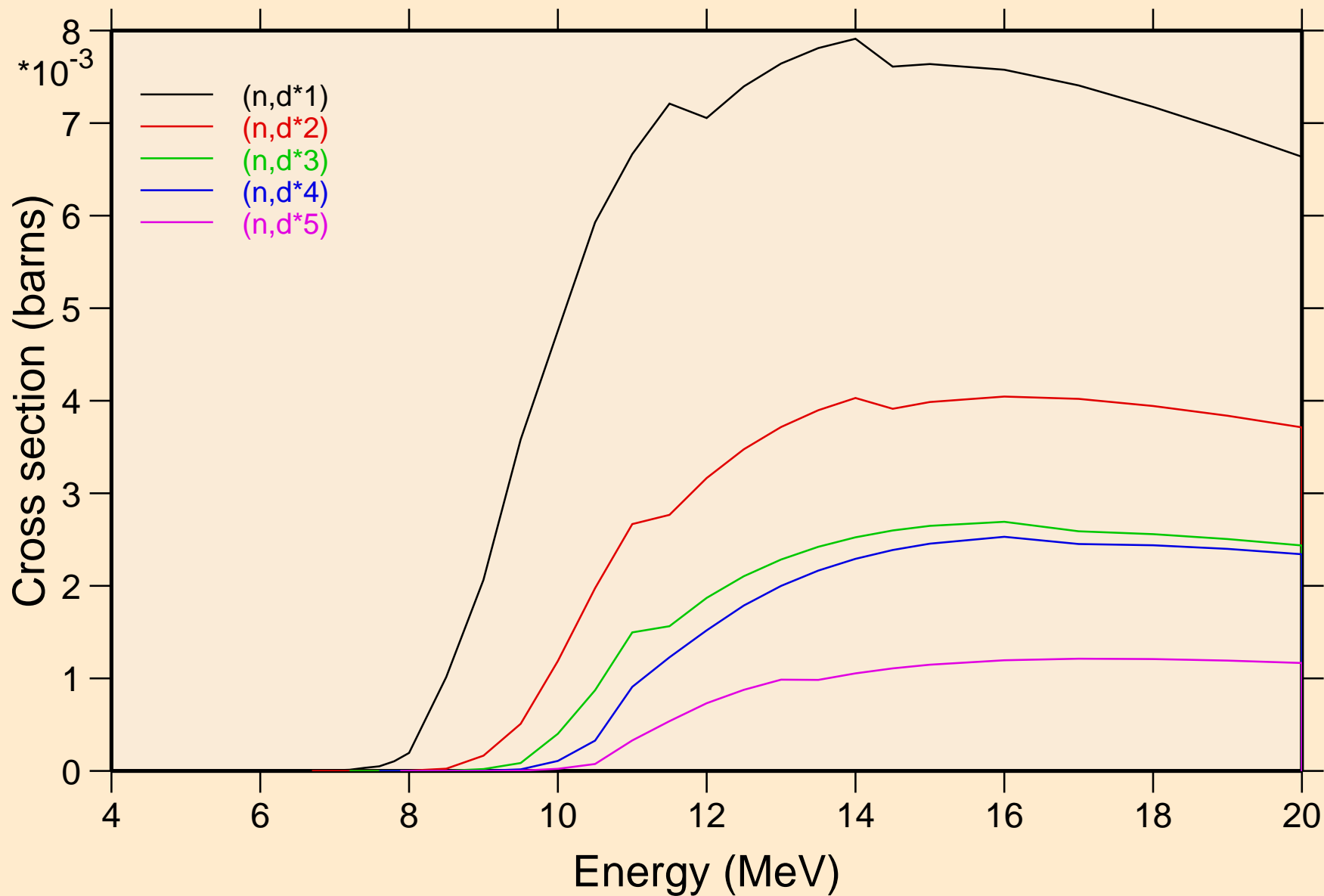

# 21-SC-45 FOR FENDL-3.1 FROM JEFF-3.1.1 WITH NJOY2012.50+

## Threshold reactions

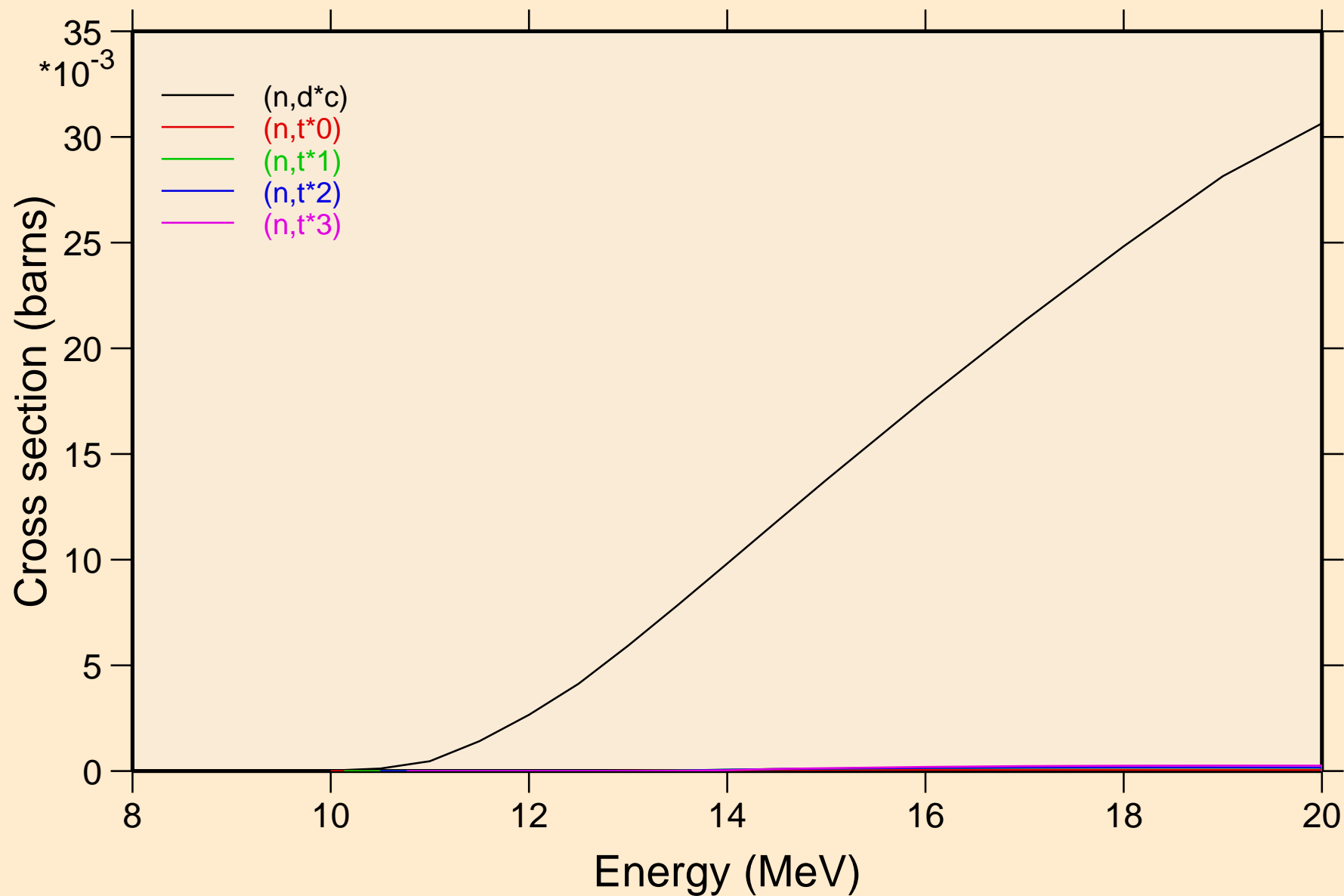

# 21-SC-45 FOR FENDL-3.1 FROM JEFF-3.1.1 WITH NJOY2012.50+

## Threshold reactions

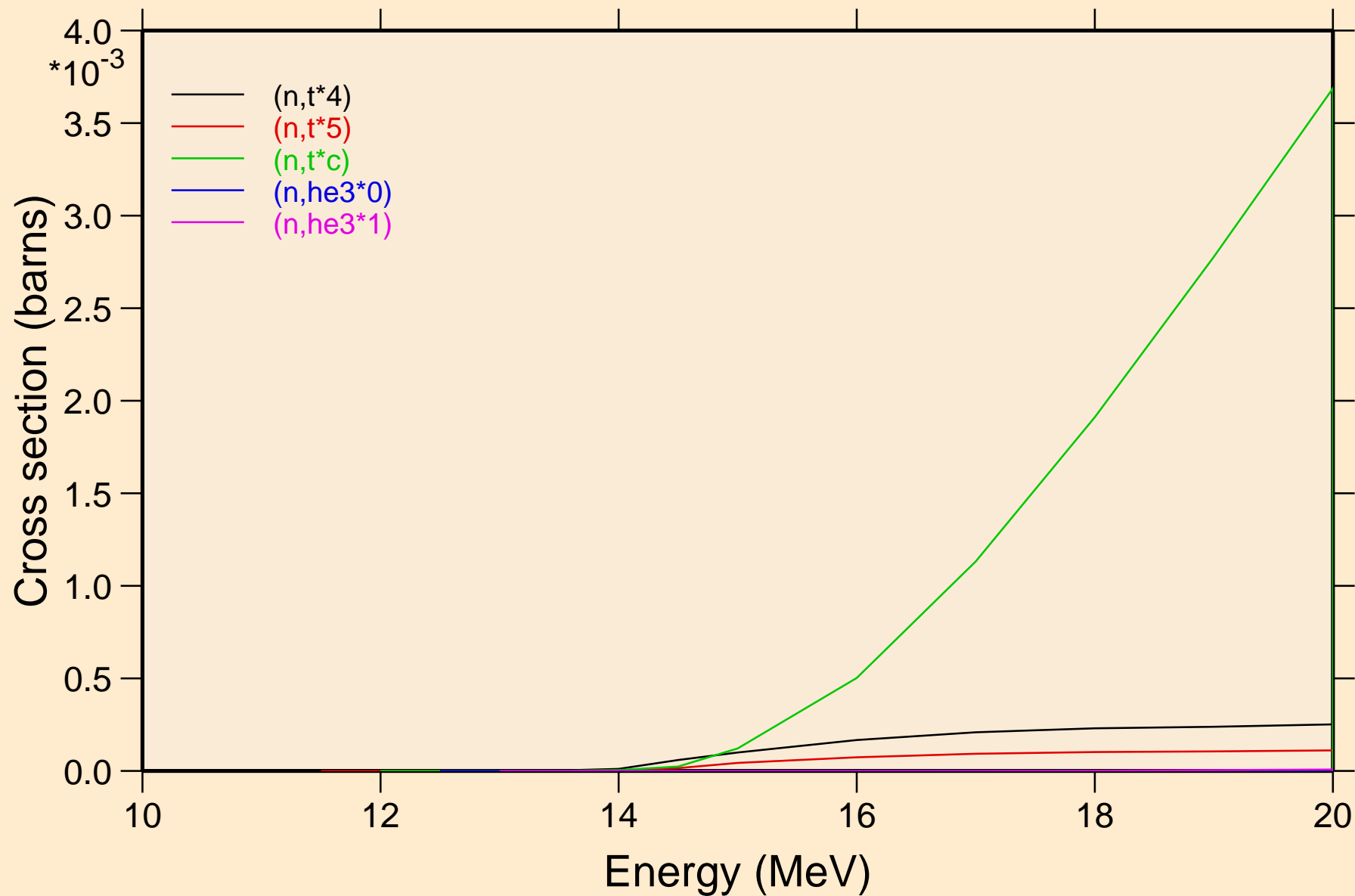



# 21-SC-45 FOR FENDL-3.1 FROM JEFF-3.1.1 WITH NJOY2012.50+

## Threshold reactions

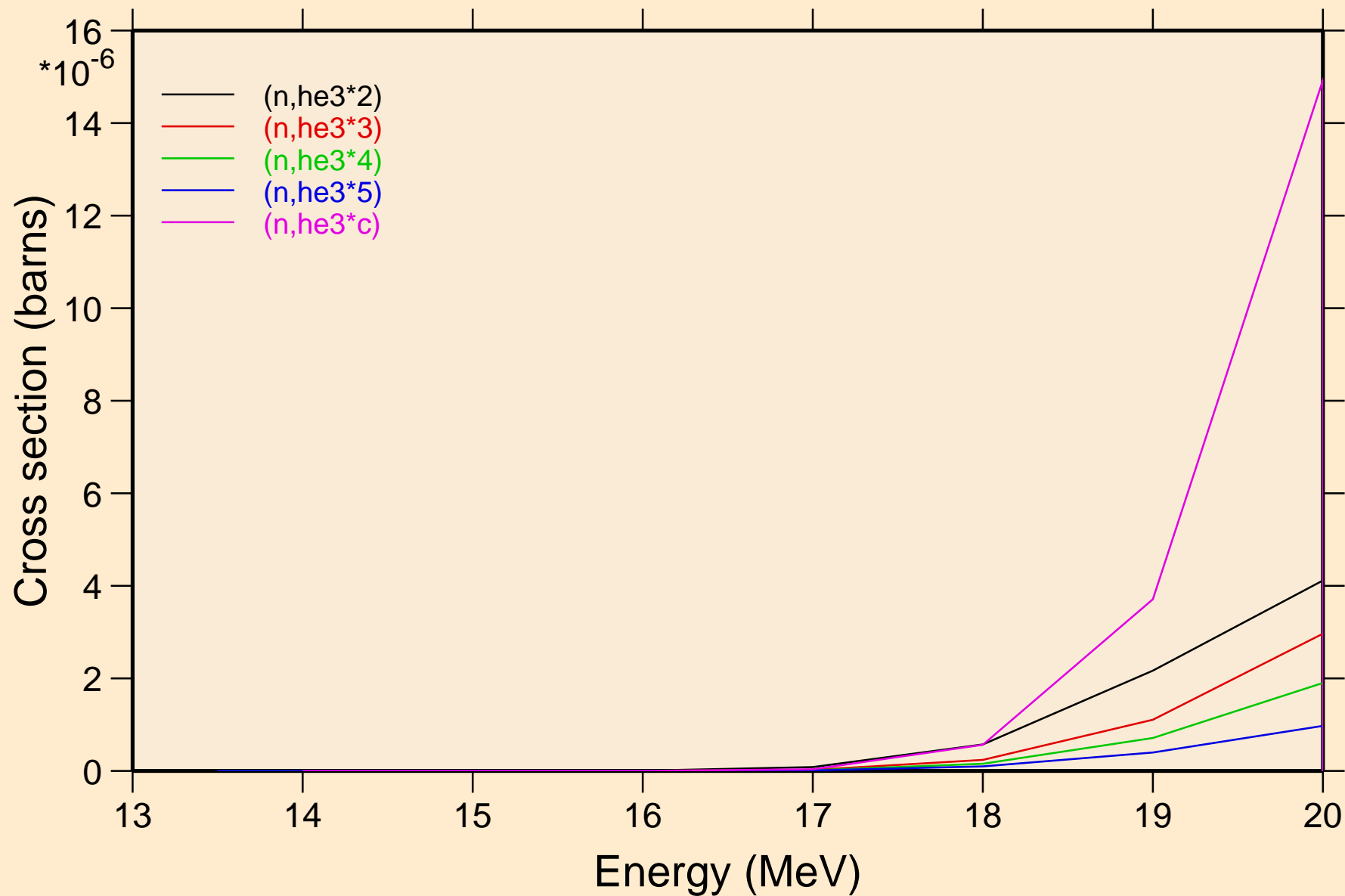

# 21-SC-45 FOR FENDL-3.1 FROM JEFF-3.1.1 WITH NJOY2012.50+

## Threshold reactions

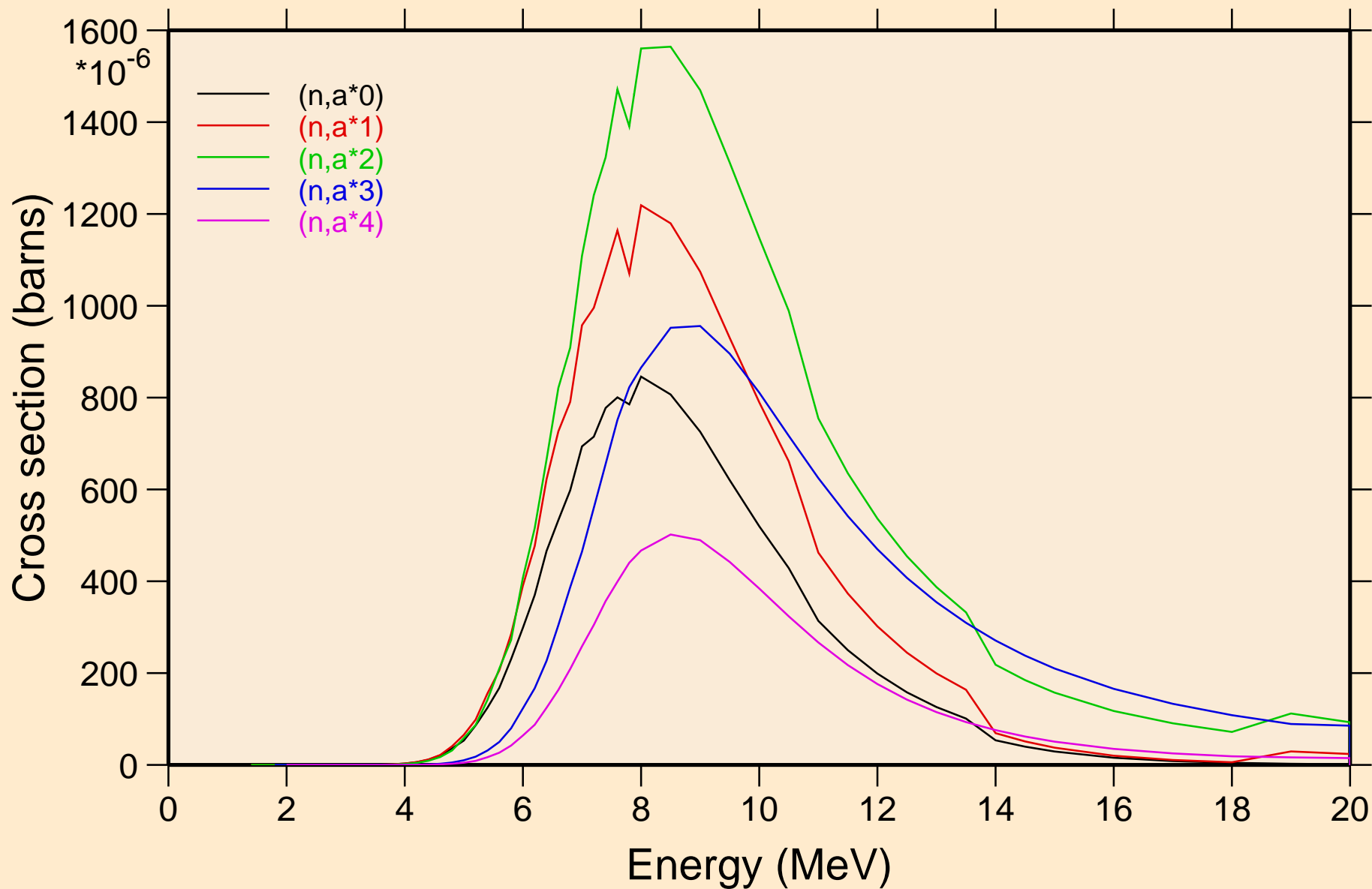

21-SC-45 FOR FENDL-3.1 FROM JEFF-3.1.1 WITH NJOY2012.50+  
Threshold reactions

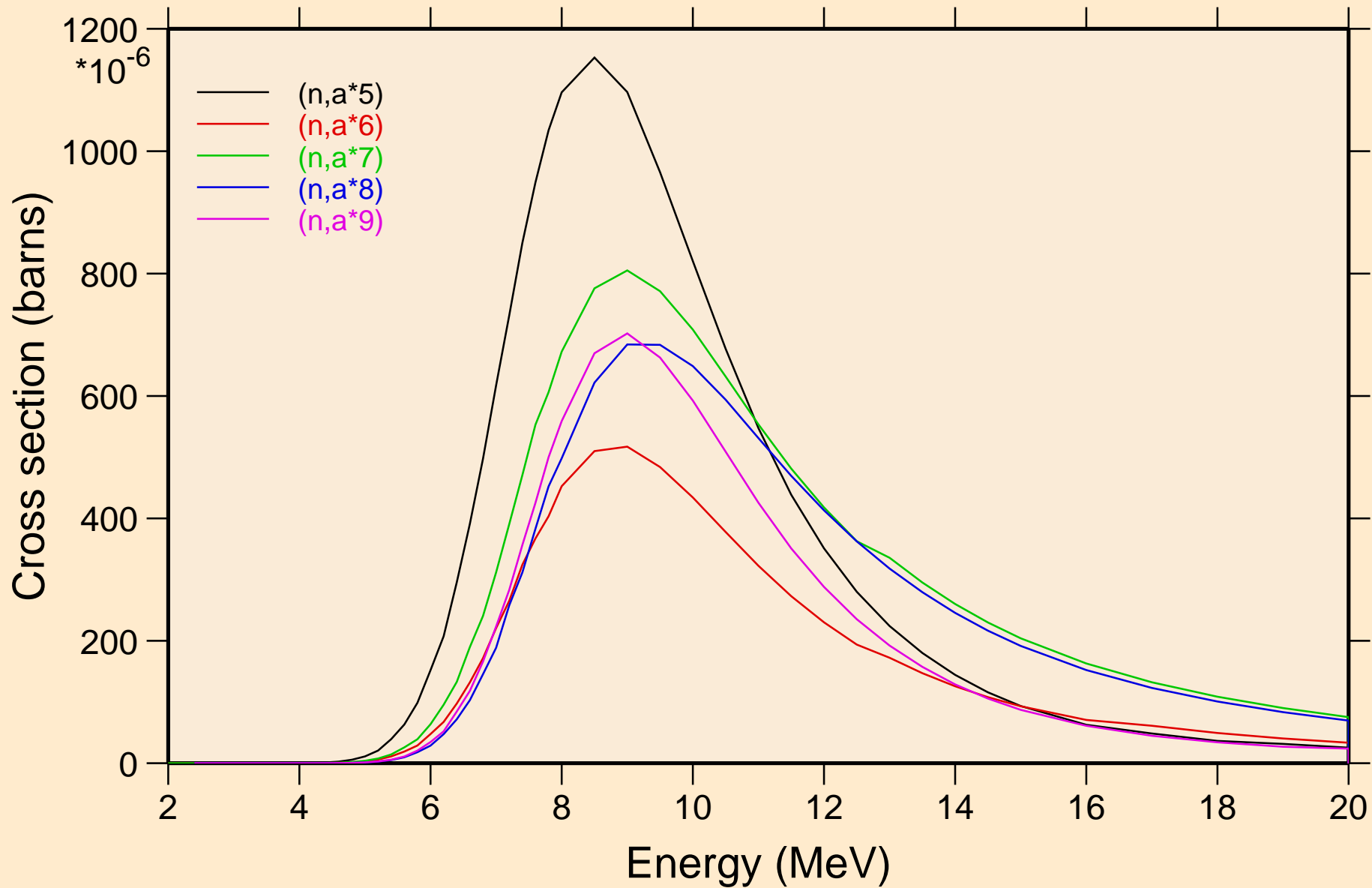

21-SC-45 FOR FENDL-3.1 FROM JEFF-3.1.1 WITH NJOY2012.50+  
Threshold reactions

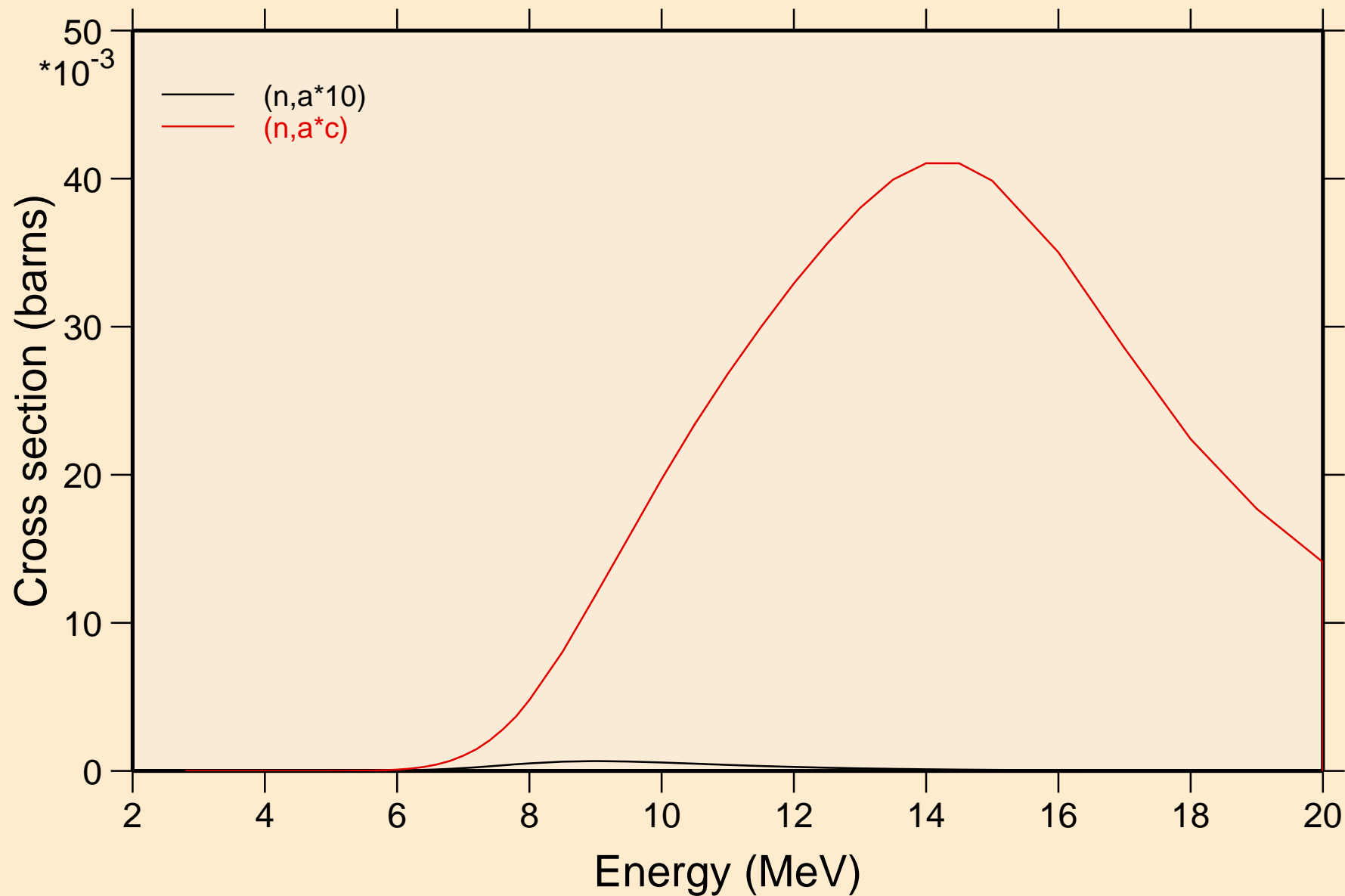

21-SC-45 FOR FENDL-3.1 FROM JEFF-3.1.1 WITH NJOY2012.50+  
angular distribution for elastic

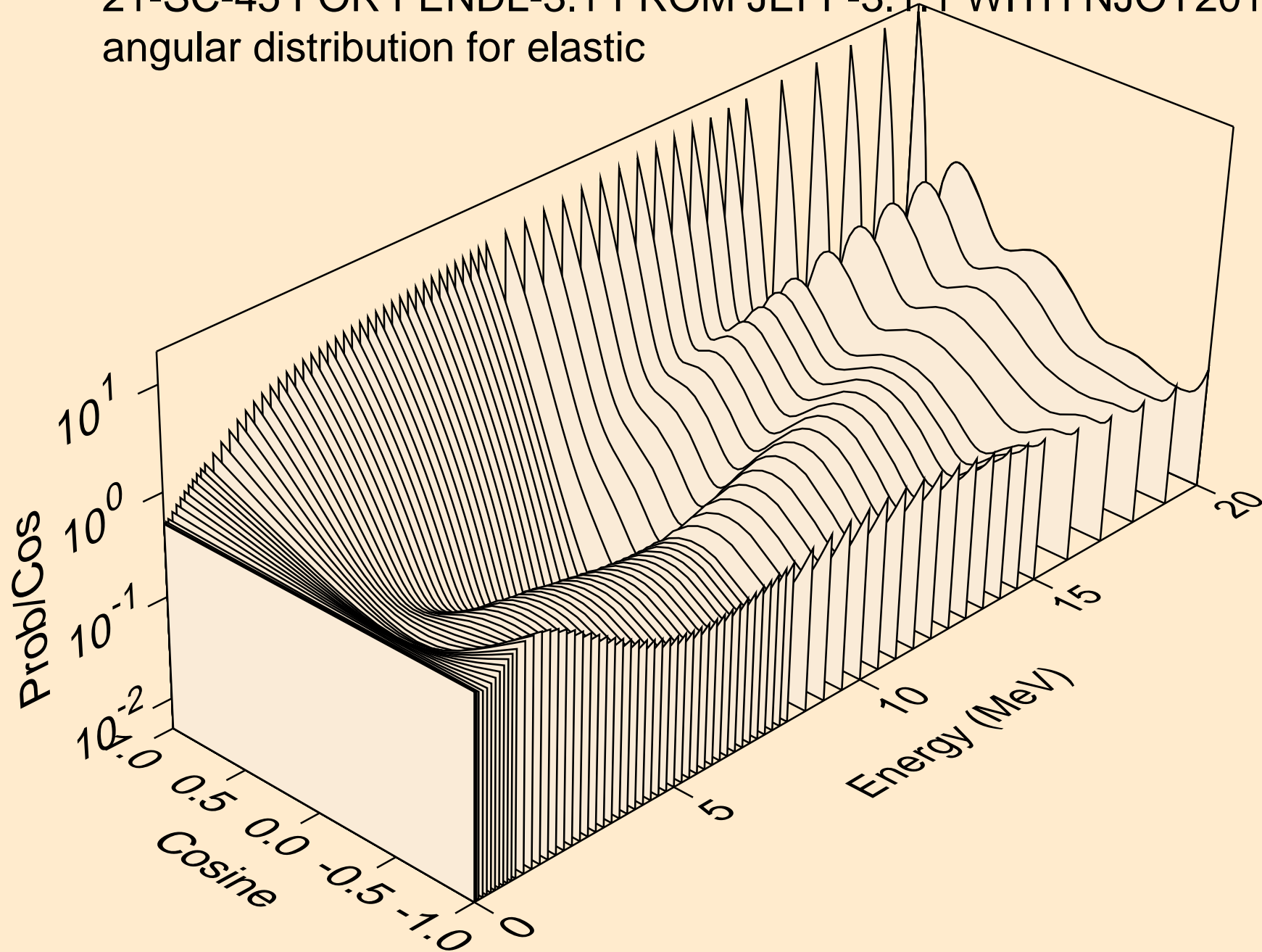

21-SC-45 FOR FENDL-3.1 FROM JEFF-3.1.1 WITH NJOY2012.50+  
angular distribution for elastic

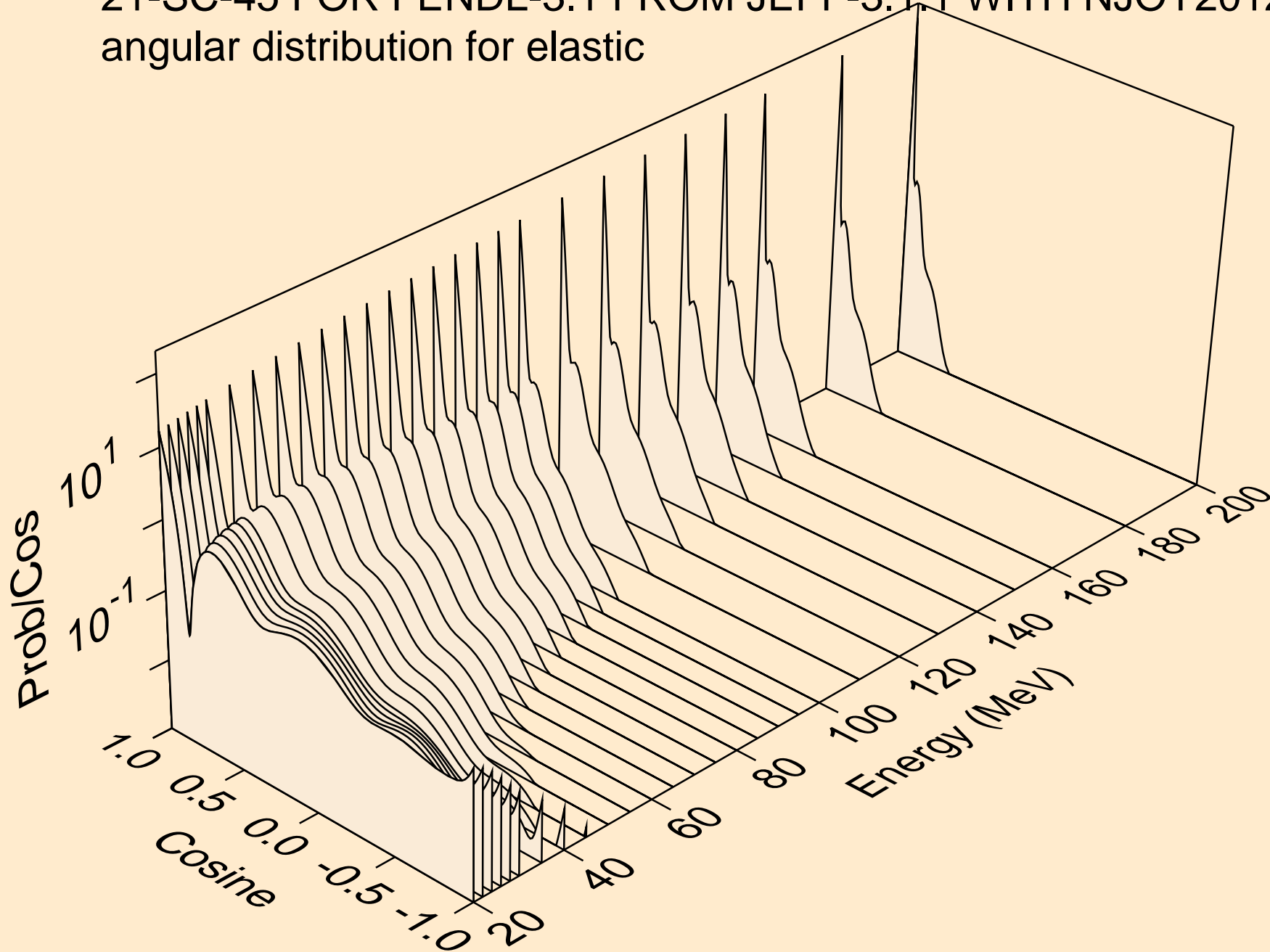

21-SC-45 FOR FENDL-3.1 FROM JEFF-3.1.1 WITH NJOY2012.50+  
angular distribution for (n,n\*1)

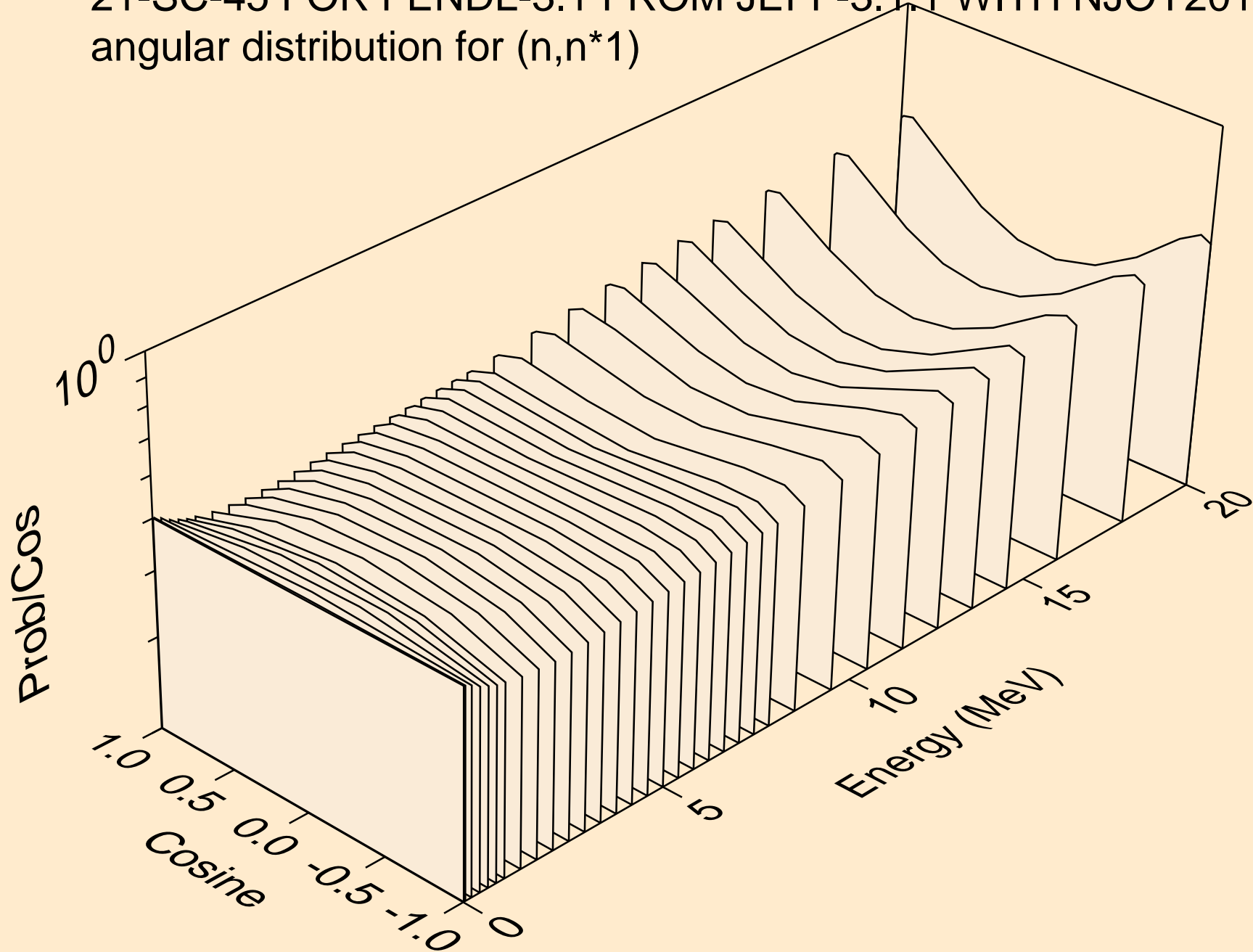

21-SC-45 FOR FENDL-3.1 FROM JEFF-3.1.1 WITH NJOY2012.50+  
angular distribution for (n,n\*2)

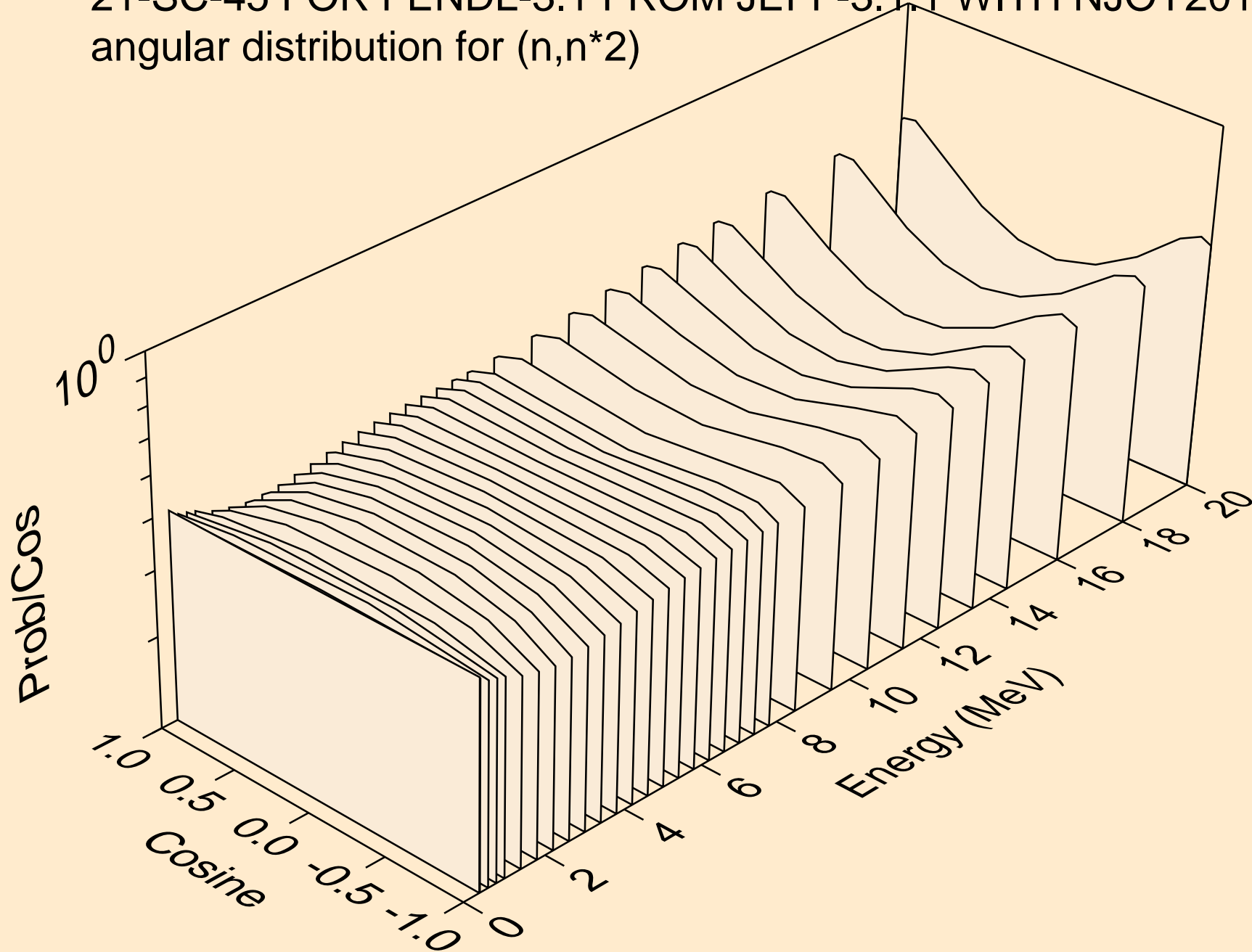



21-SC-45 FOR FENDL-3.1 FROM JEFF-3.1.1 WITH NJOY2012.50+  
angular distribution for (n,n\*3)

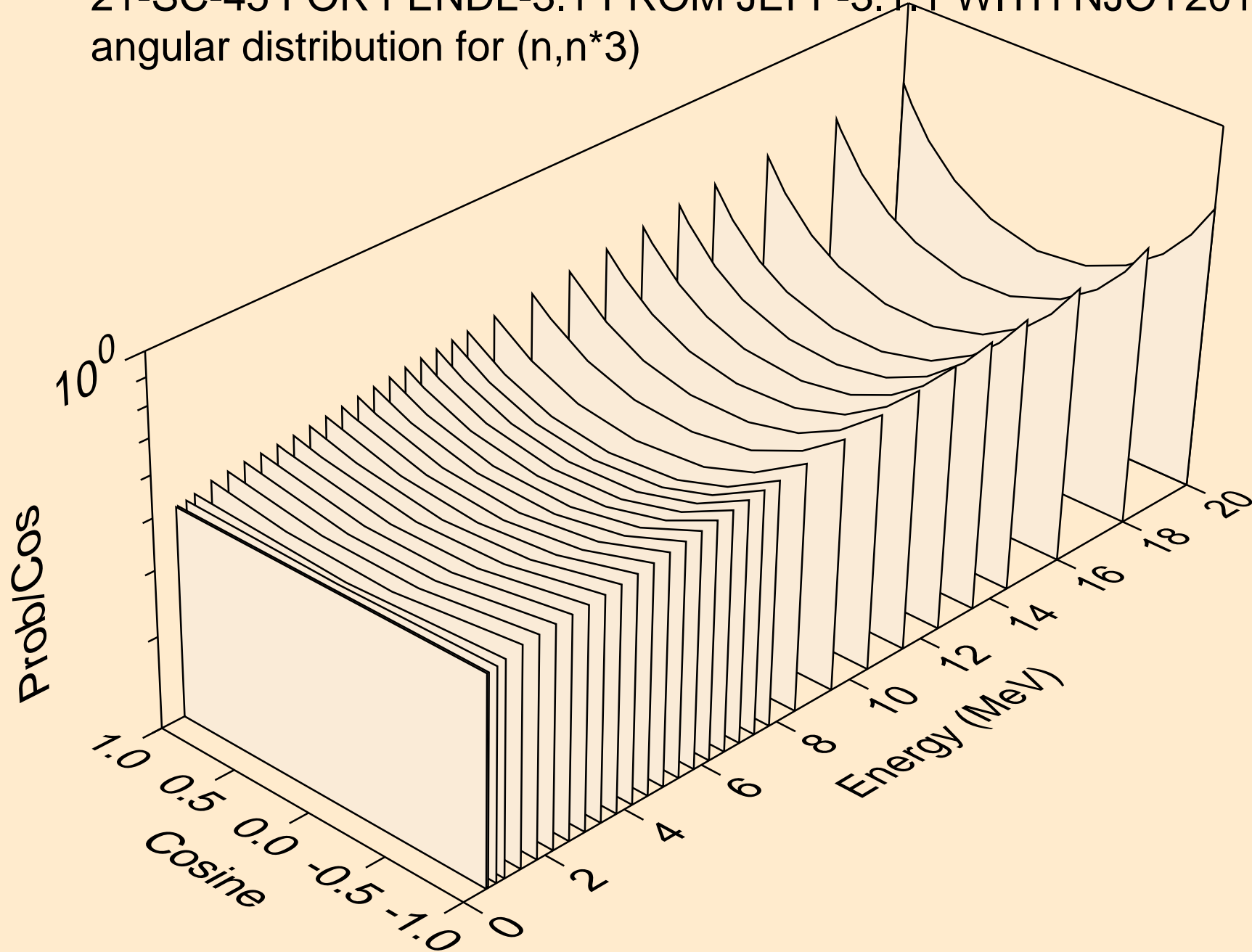

21-SC-45 FOR FENDL-3.1 FROM JEFF-3.1.1 WITH NJOY2012.50+  
angular distribution for (n,n\*4)

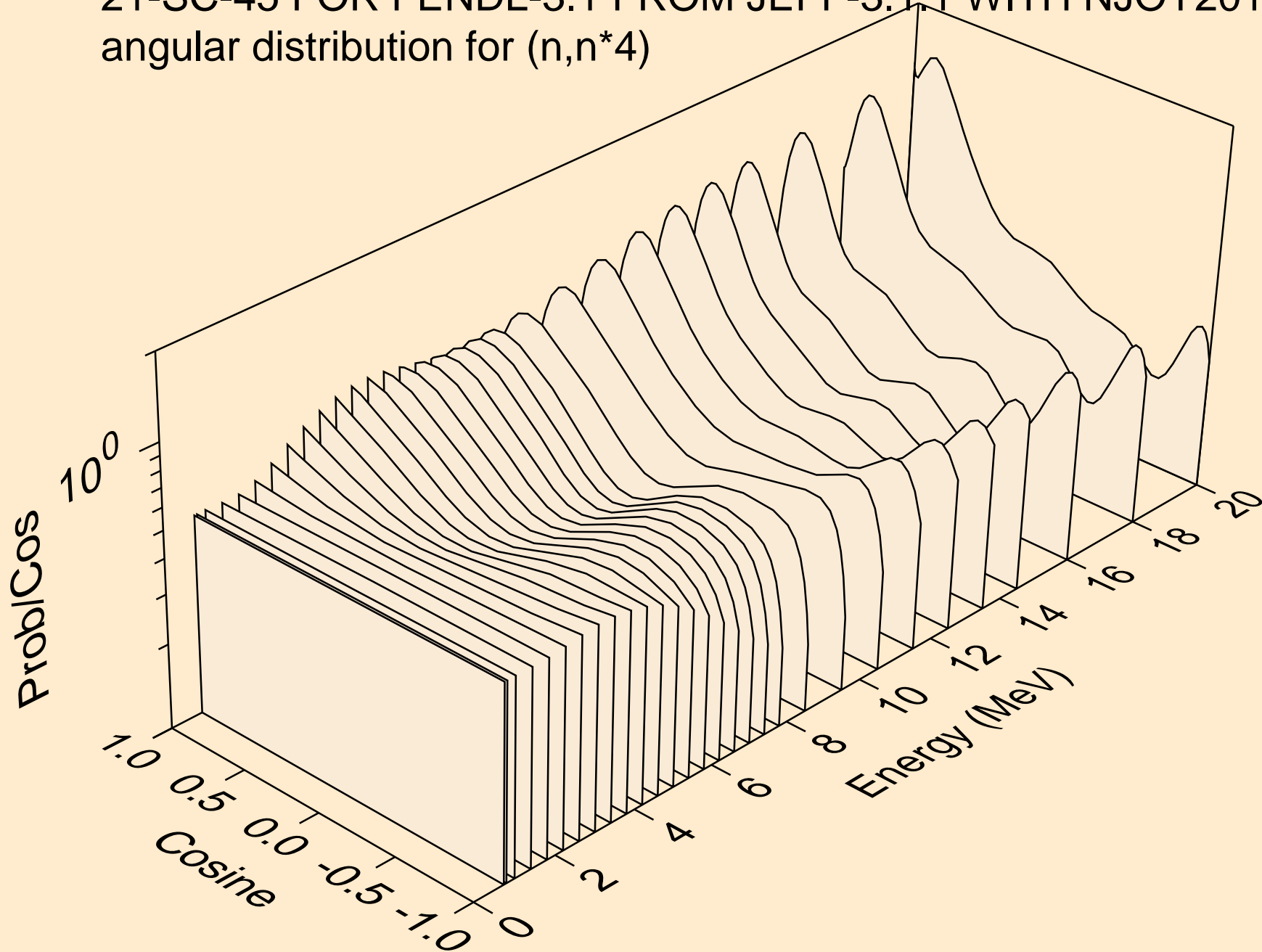

21-SC-45 FOR FENDL-3.1 FROM JEFF-3.1.1 WITH NJOY2012.50+  
angular distribution for (n,n\*5)

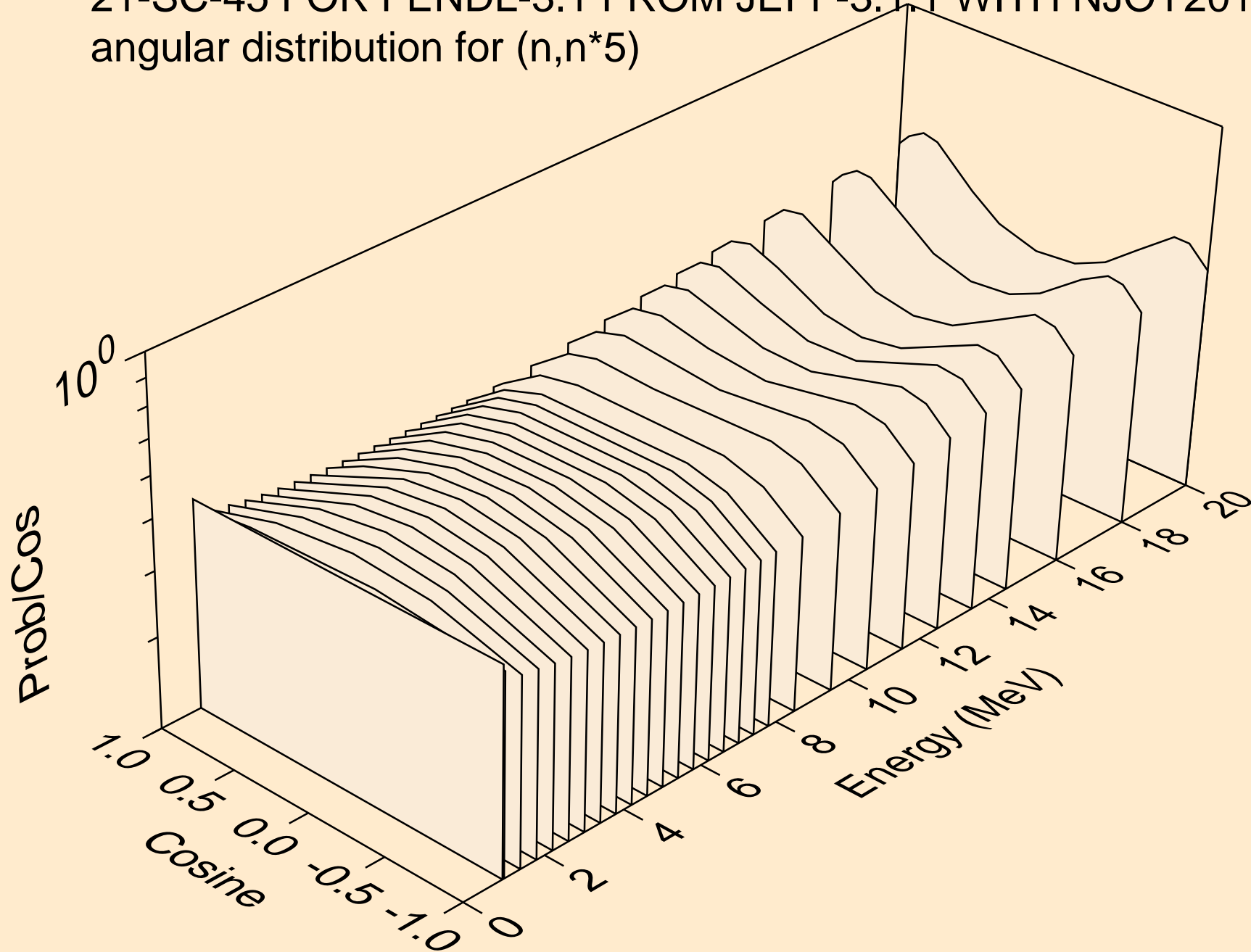

21-SC-45 FOR FENDL-3.1 FROM JEFF-3.1.1 WITH NJOY2012.50+  
angular distribution for (n,n\*6)

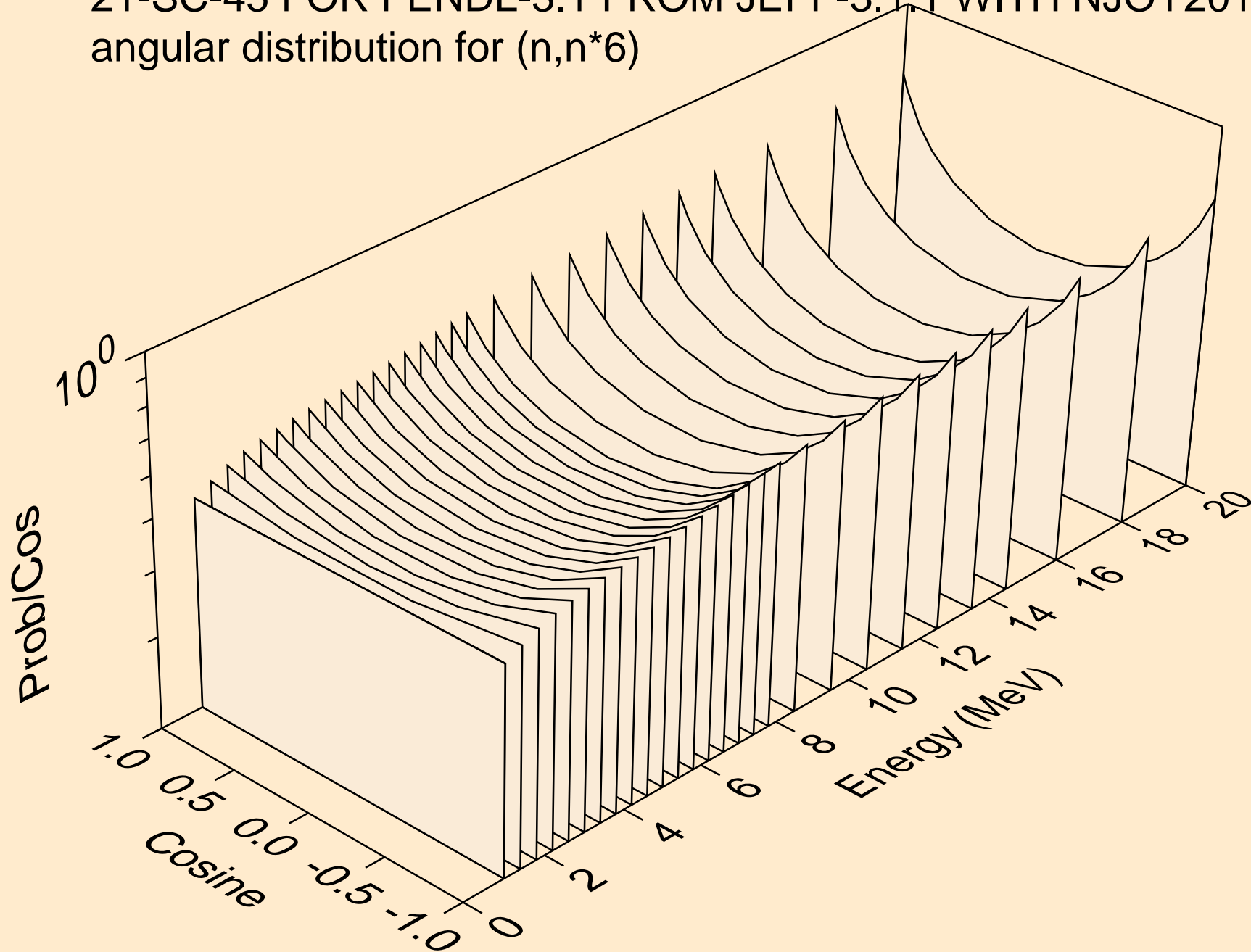

21-SC-45 FOR FENDL-3.1 FROM JEFF-3.1.1 WITH NJOY2012.50+  
angular distribution for (n,n\*7)

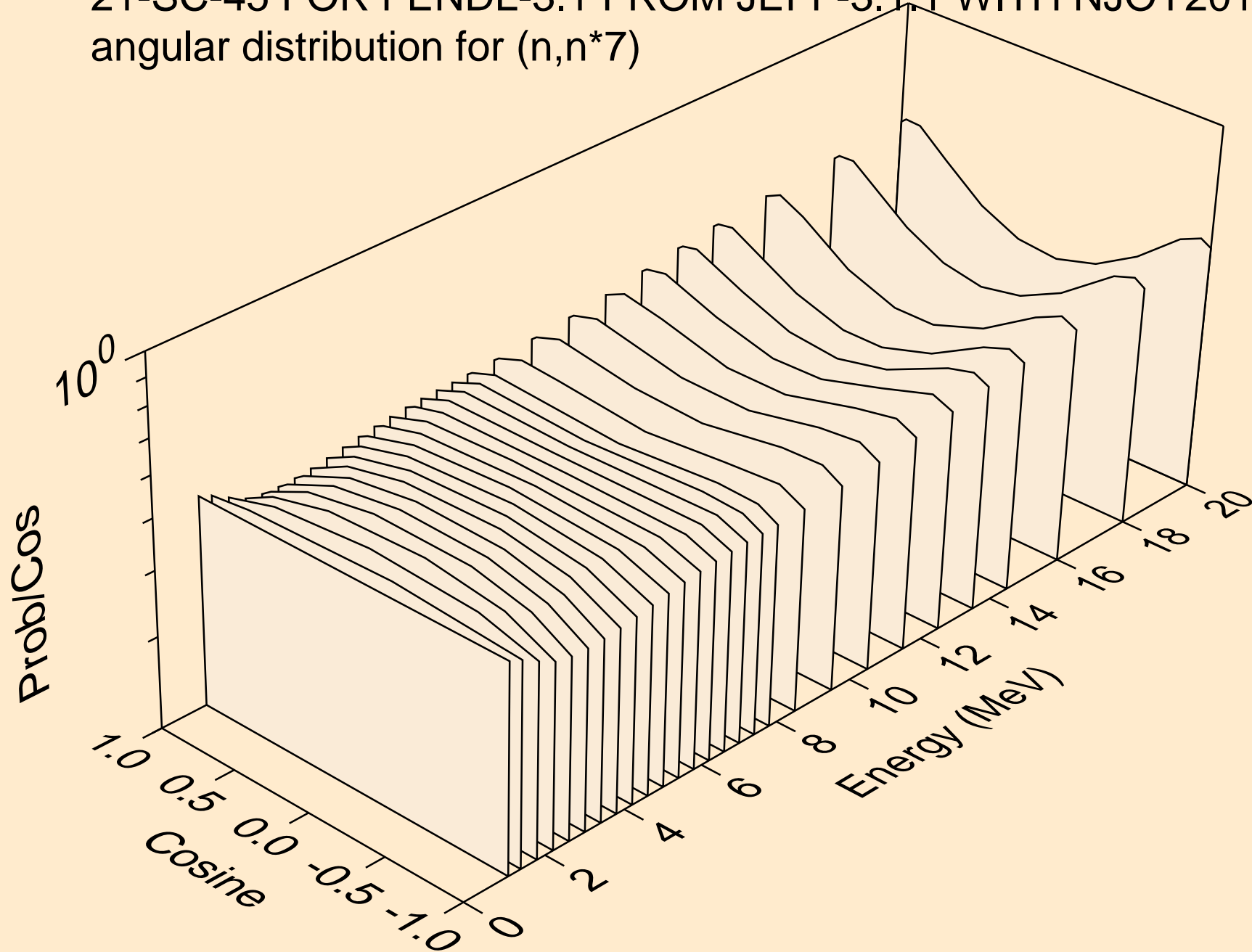

21-SC-45 FOR FENDL-3.1 FROM JEFF-3.1.1 WITH NJOY2012.50+  
angular distribution for (n,n\*8)

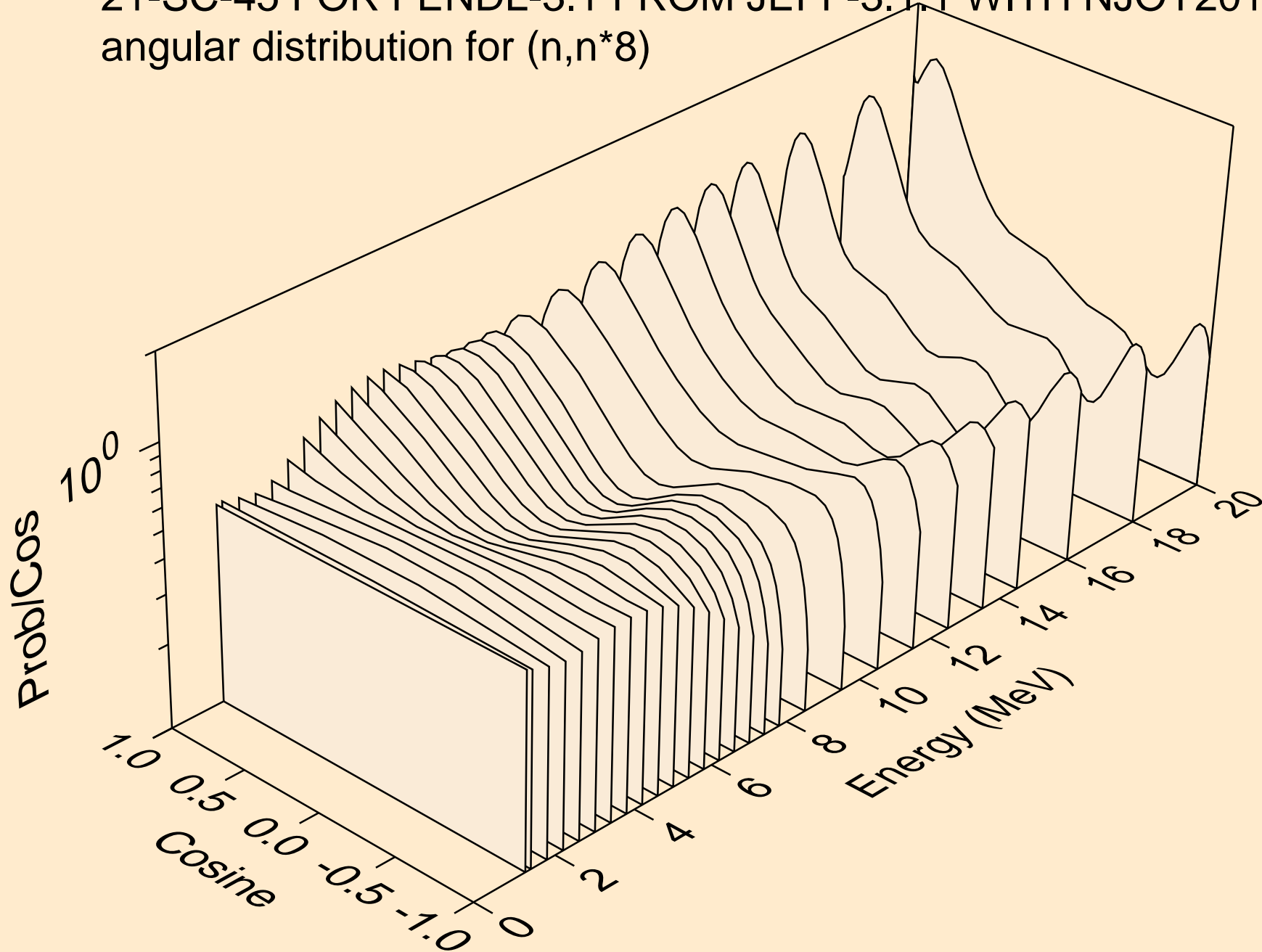

21-SC-45 FOR FENDL-3.1 FROM JEFF-3.1.1 WITH NJOY2012.50+  
angular distribution for (n,n\*9)

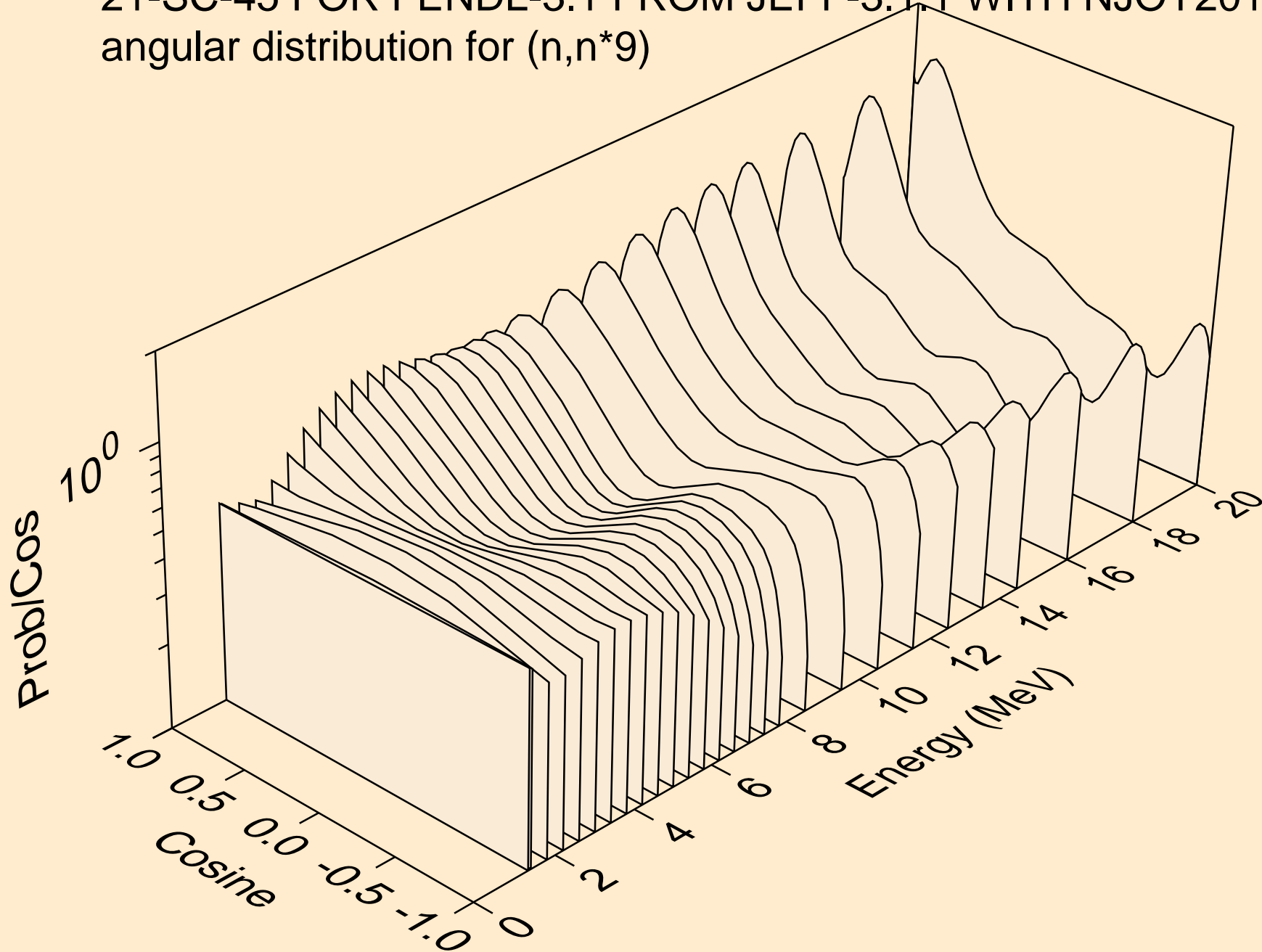

21-SC-45 FOR FENDL-3.1 FROM JEFF-3.1.1 WITH NJOY2012.50+  
angular distribution for (n,n\*10)

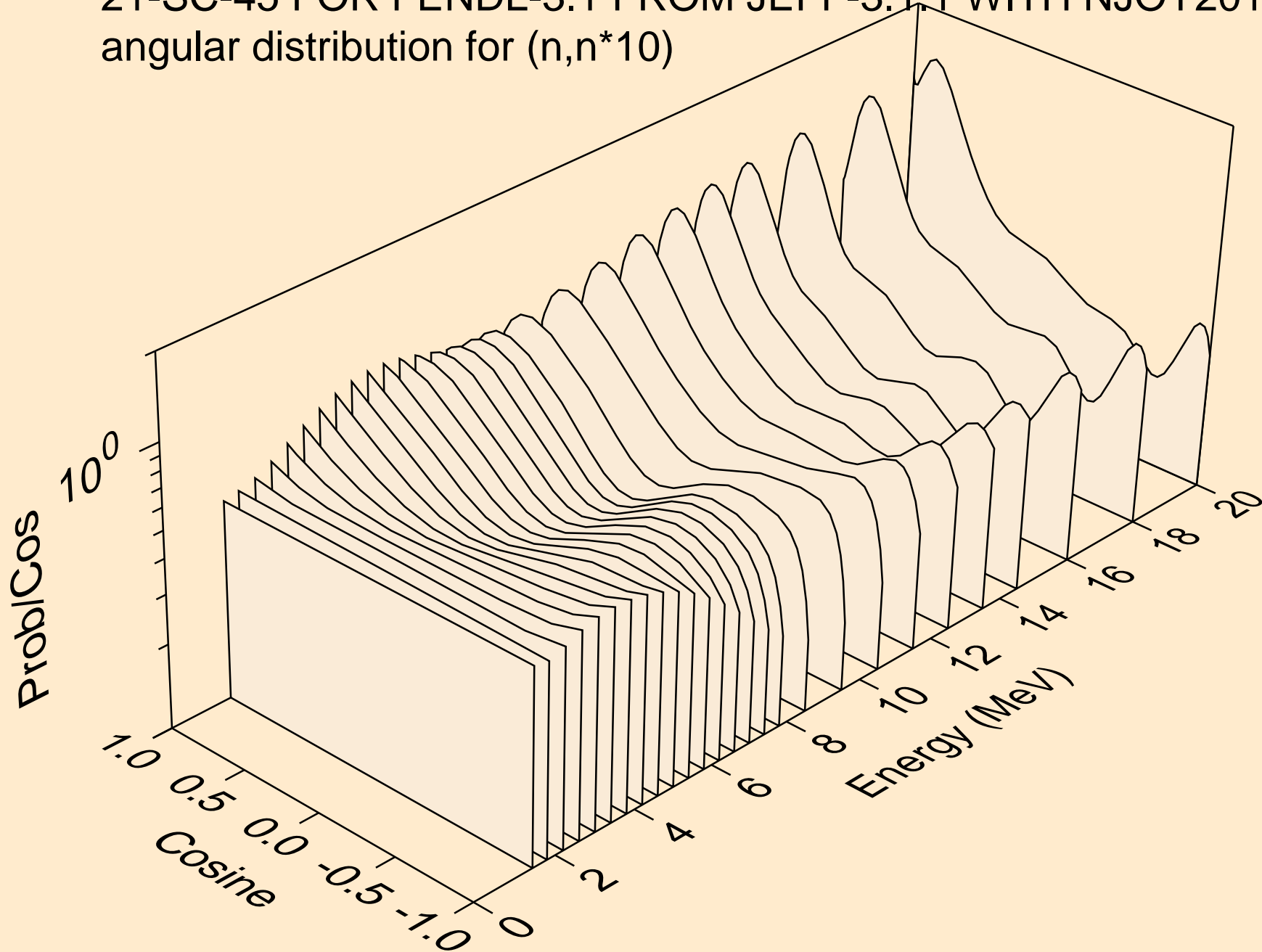



21-SC-45 FOR FENDL-3.1 FROM JEFF-3.1.1 WITH NJOY2012.50+  
angular distribution for (n,n\*11)

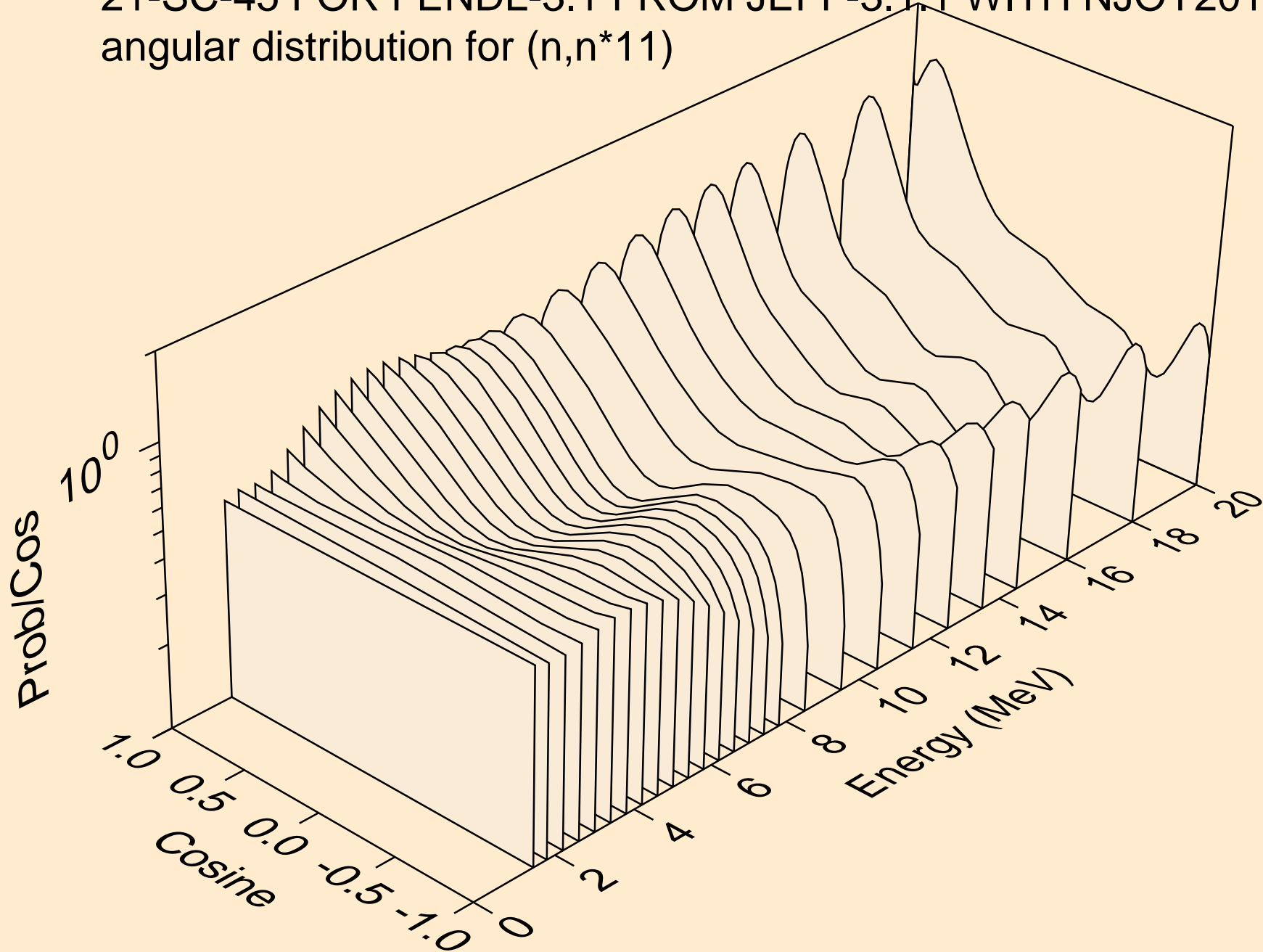

21-SC-45 FOR FENDL-3.1 FROM JEFF-3.1.1 WITH NJOY2012.50+  
angular distribution for (n,n\*12)

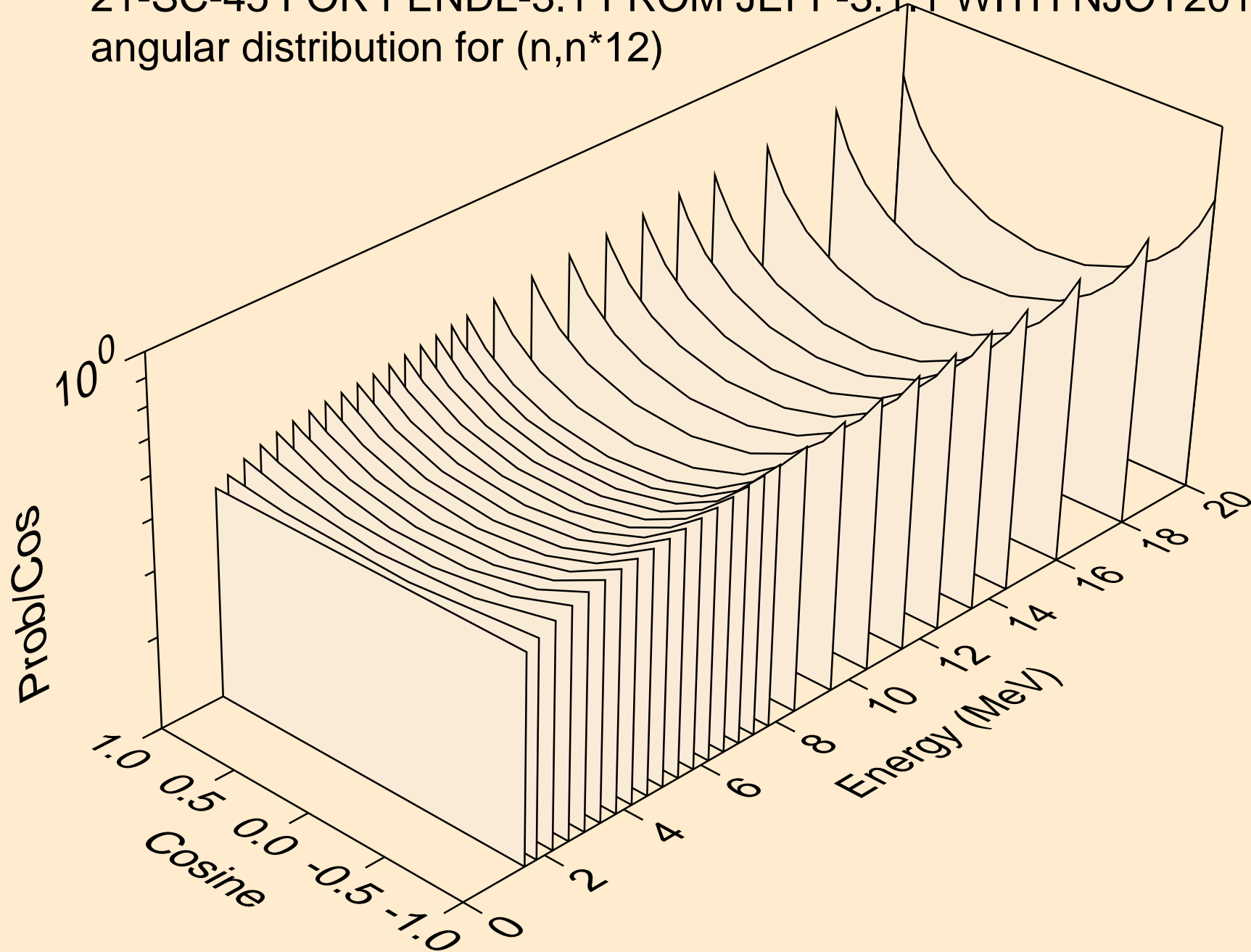

21-SC-45 FOR FENDL-3.1 FROM JEFF-3.1.1 WITH NJOY2012.50+  
angular distribution for (n,n\*13)

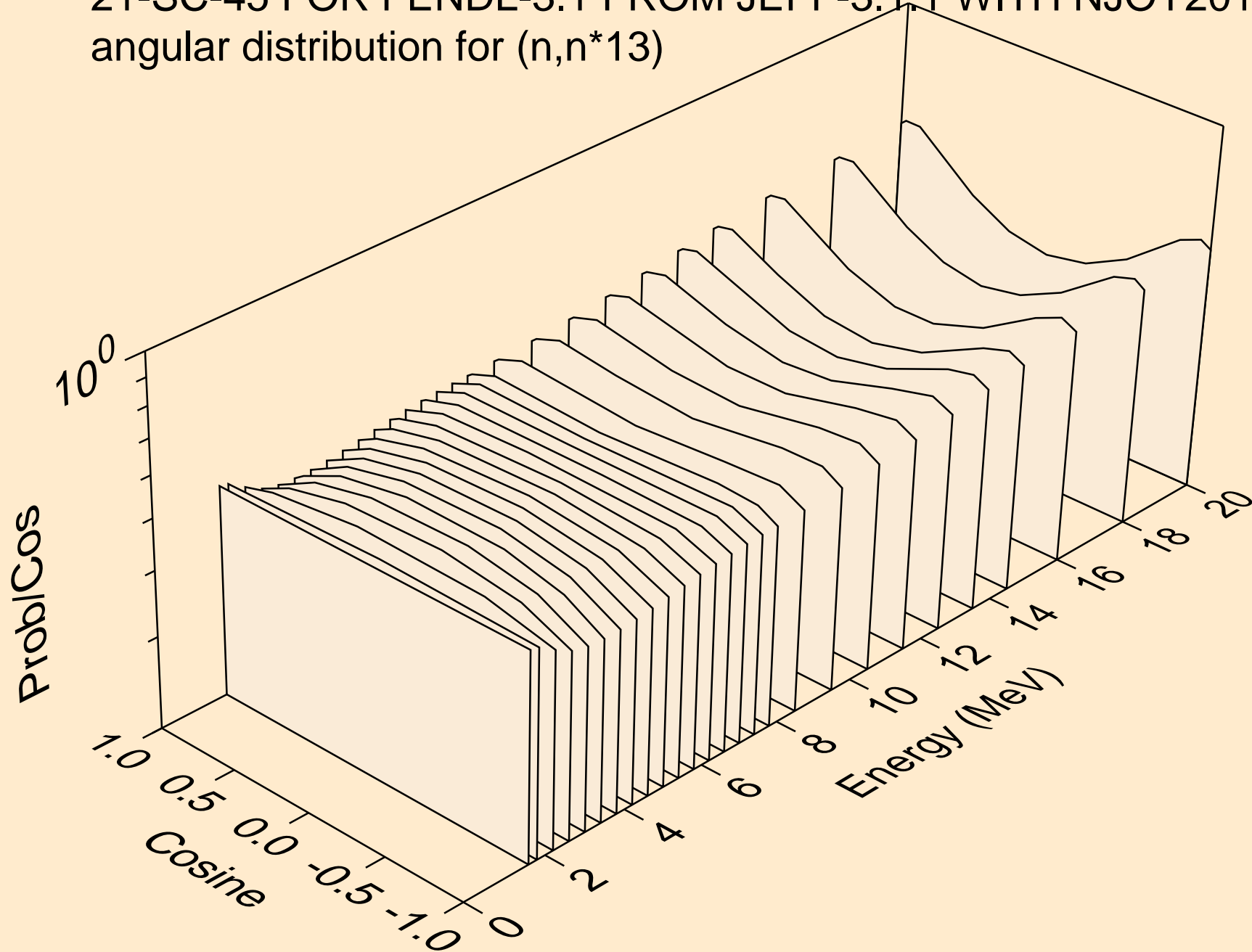

21-SC-45 FOR FENDL-3.1 FROM JEFF-3.1.1 WITH NJOY2012.50+  
angular distribution for (n,n\*14)

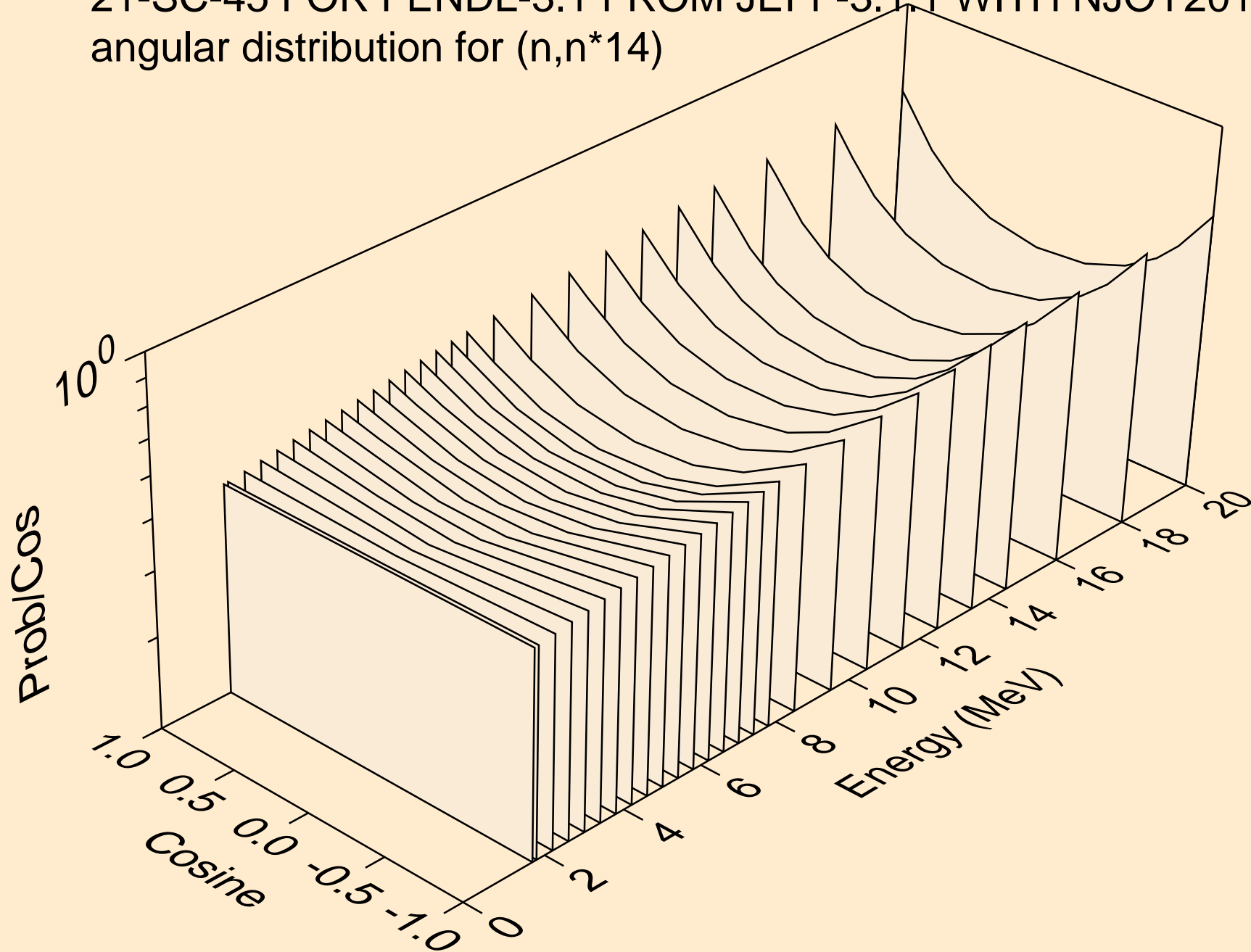

21-SC-45 FOR FENDL-3.1 FROM JEFF-3.1.1 WITH NJOY2012.50+  
angular distribution for (n,n\*15)

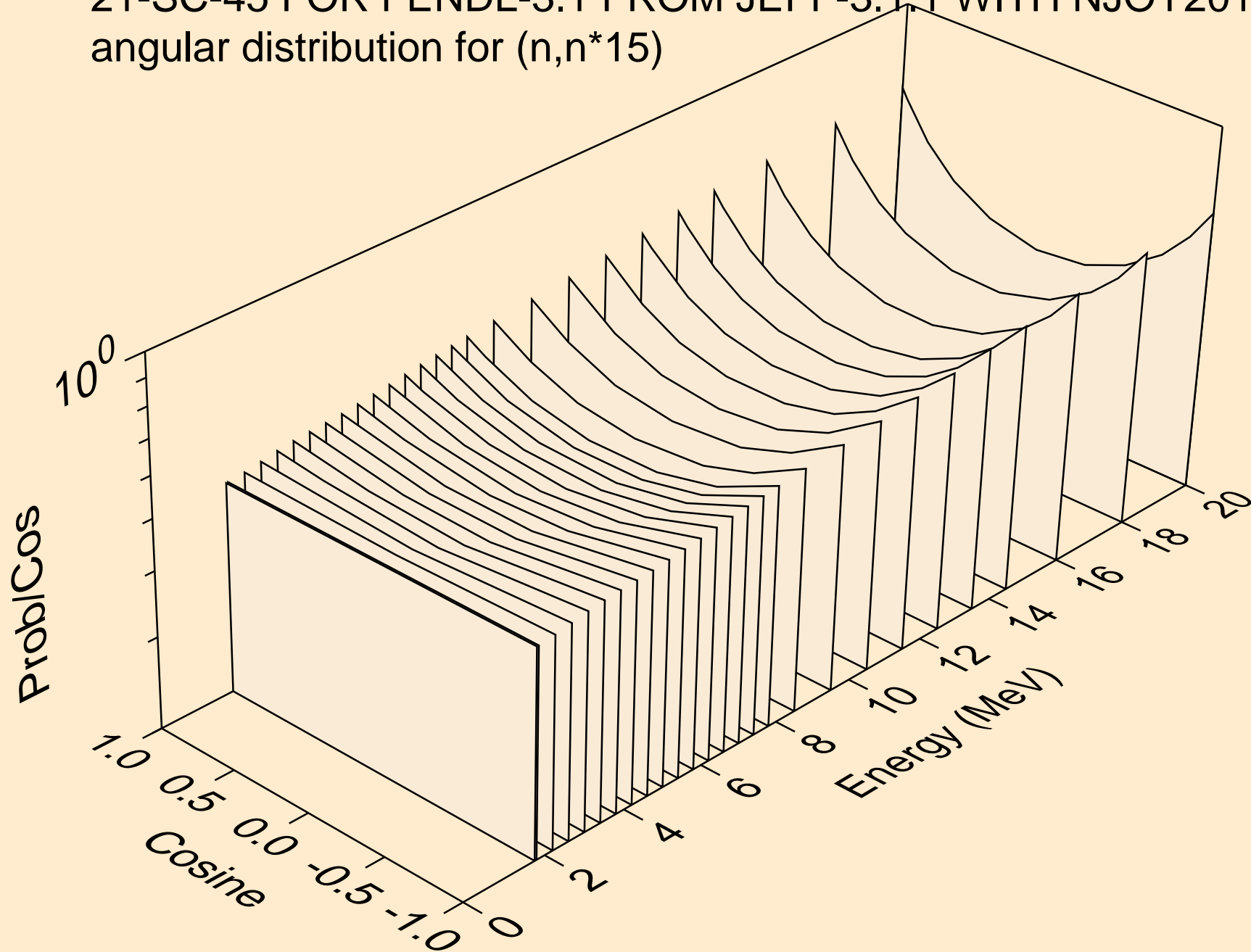

21-SC-45 FOR FENDL-3.1 FROM JEFF-3.1.1 WITH NJOY2012.50+  
angular distribution for (n,n\*16)

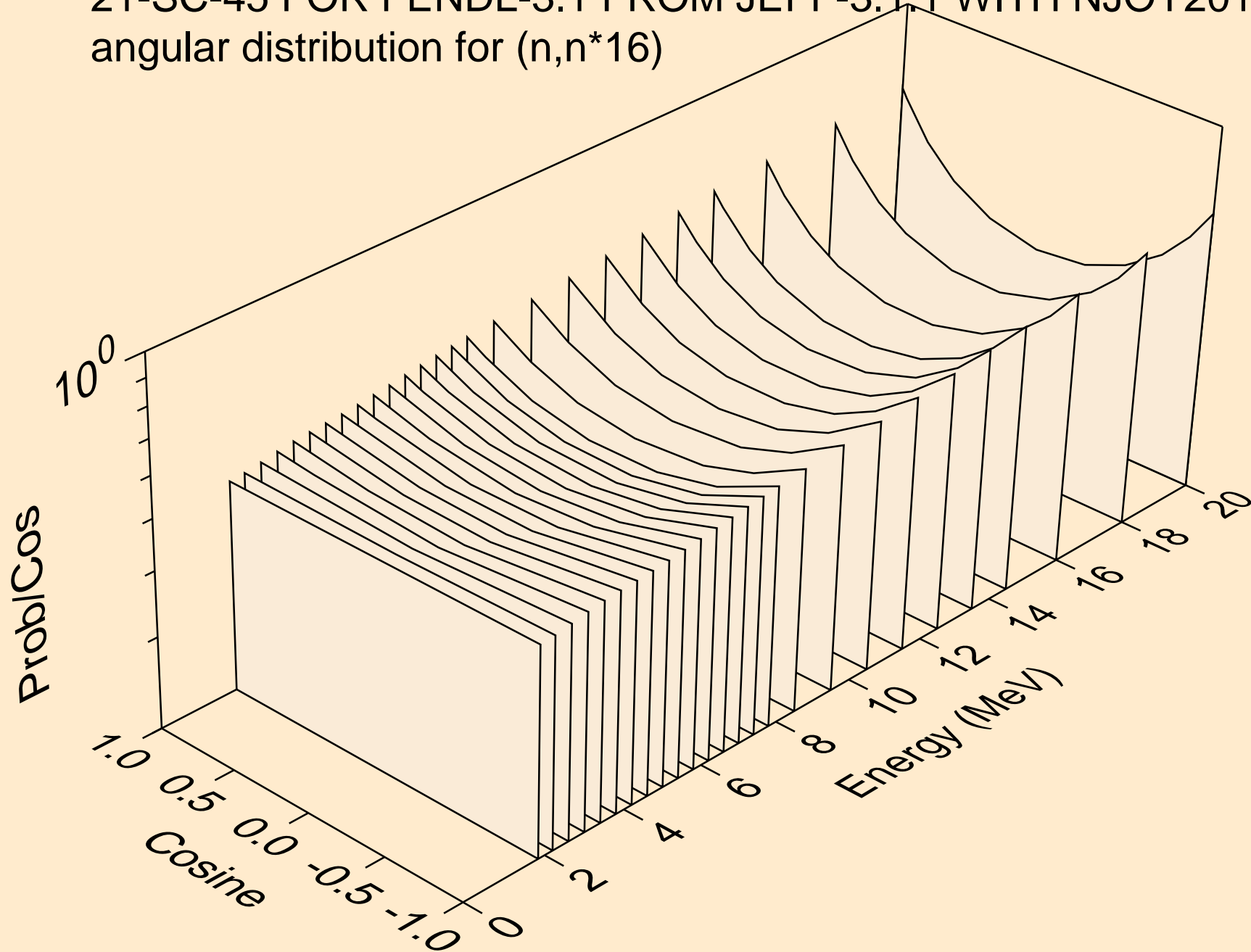

21-SC-45 FOR FENDL-3.1 FROM JEFF-3.1.1 WITH NJOY2012.50+  
angular distribution for (n,n\*17)

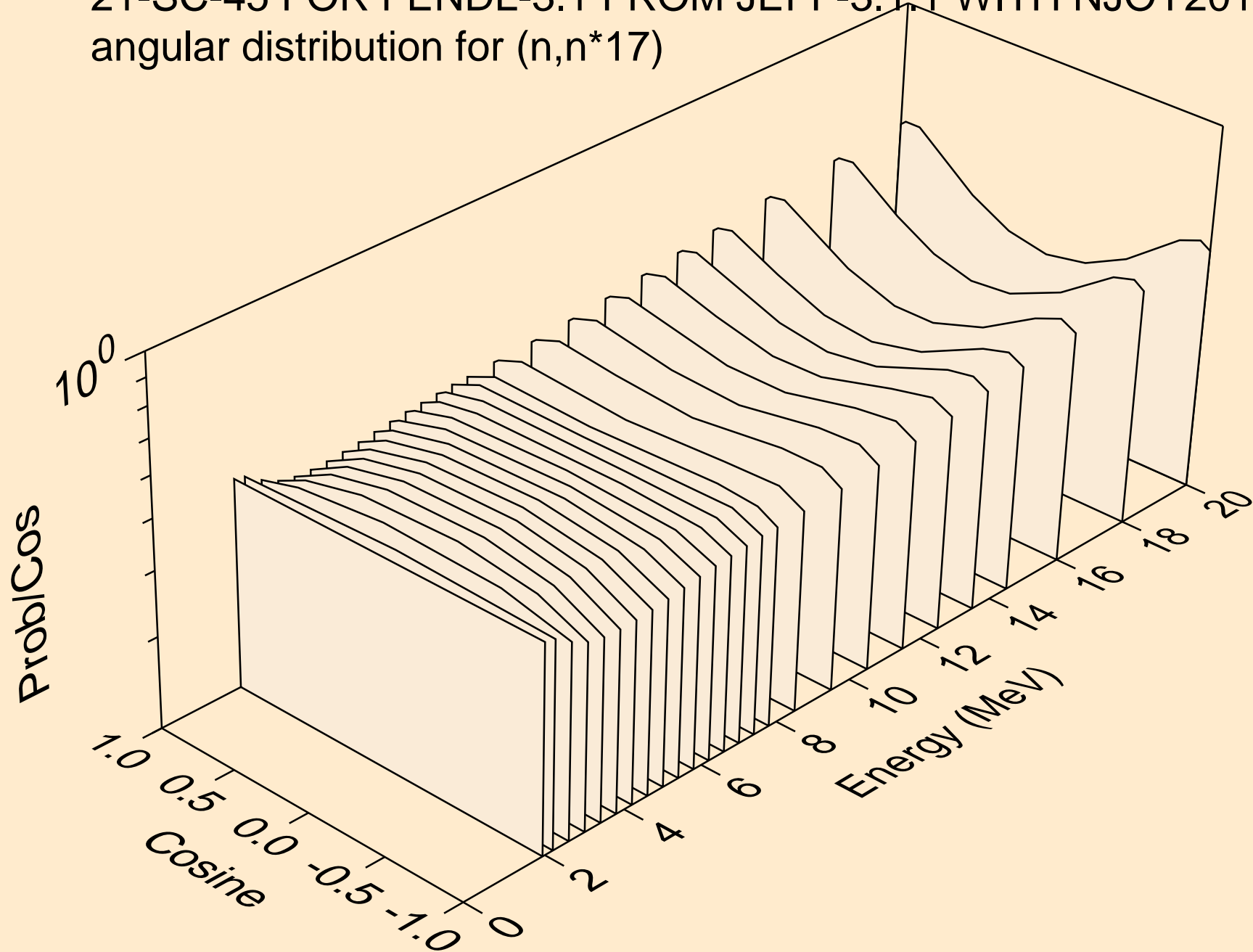

21-SC-45 FOR FENDL-3.1 FROM JEFF-3.1.1 WITH NJOY2012.50+  
angular distribution for (n,n\*18)

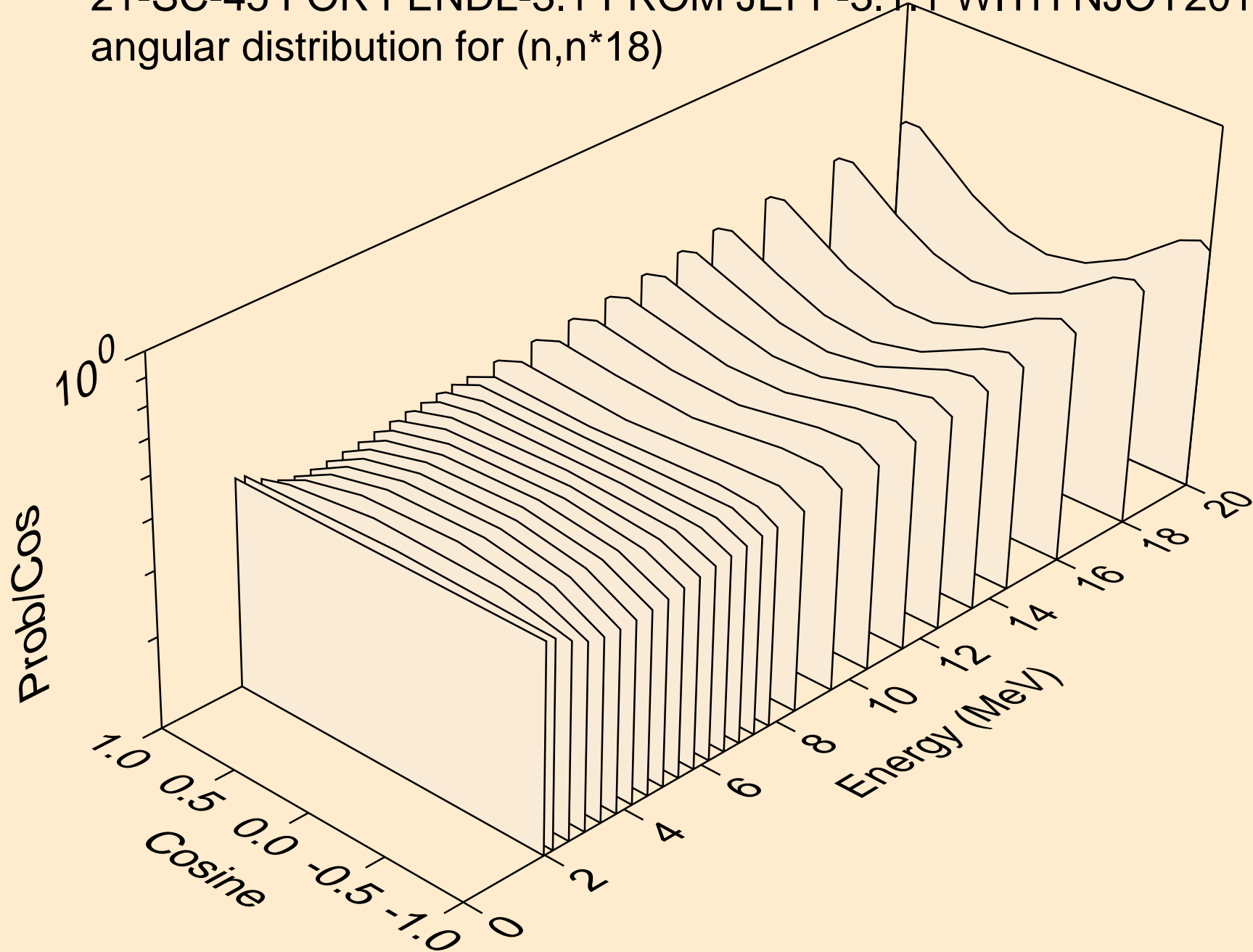



21-SC-45 FOR FENDL-3.1 FROM JEFF-3.1.1 WITH NJOY2012.50+  
angular distribution for (n,n\*19)

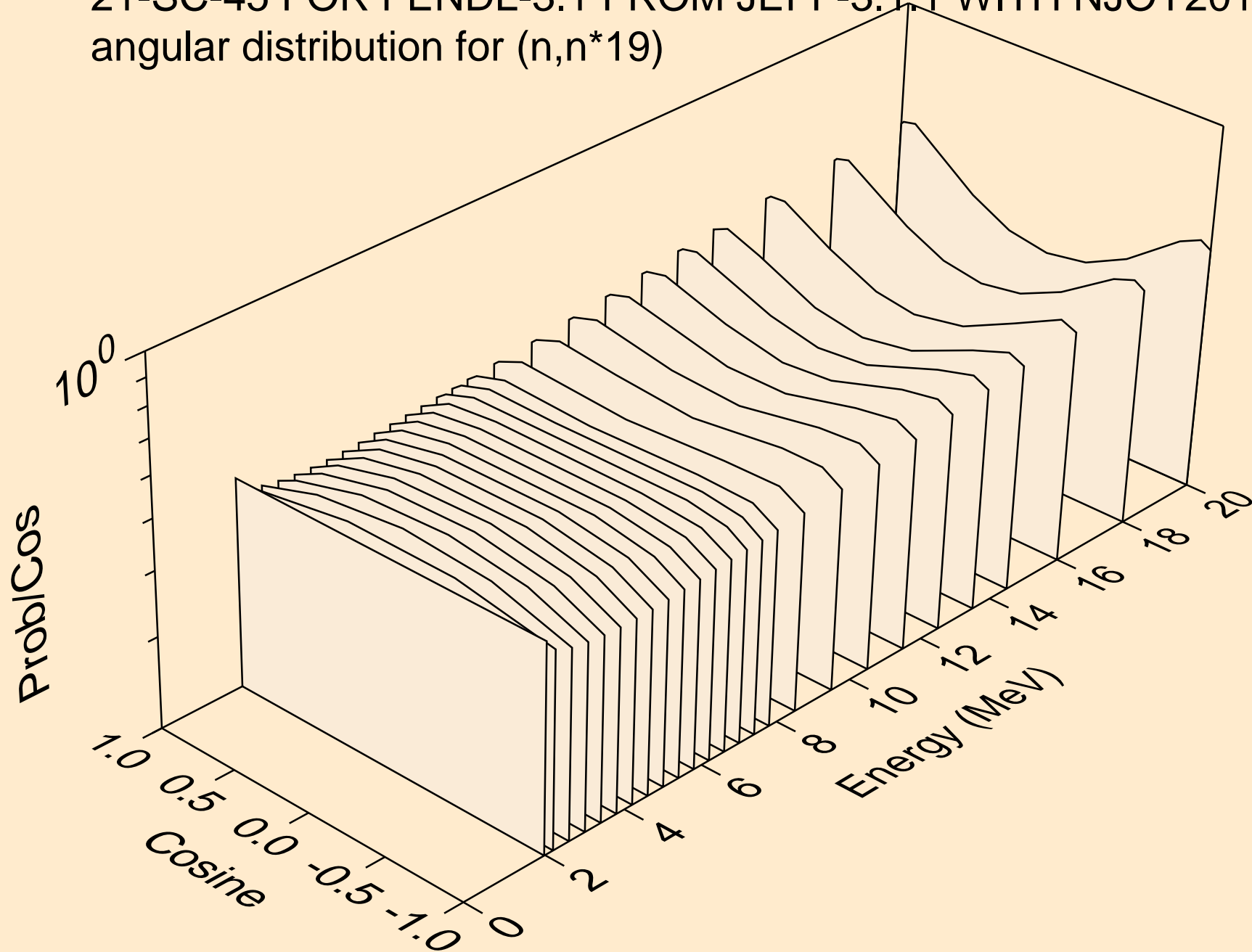

21-SC-45 FOR FENDL-3.1 FROM JEFF-3.1.1 WITH NJOY2012.50+  
angular distribution for (n,n\*20)

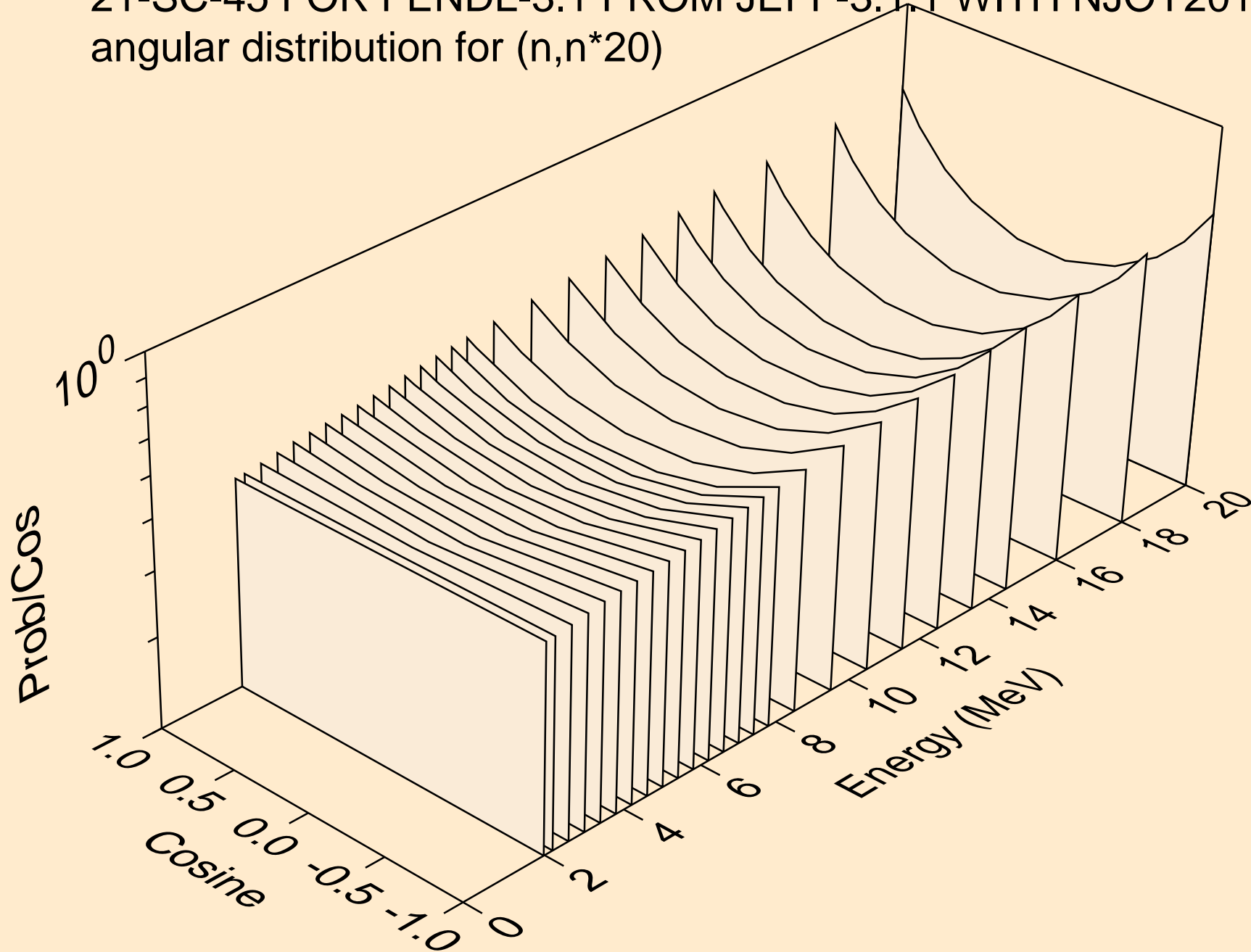

21-SC-45 FOR FENDL-3.1 FROM JEFF-3.1.1 WITH NJOY2012.50+  
Neutron emission for (n,x)

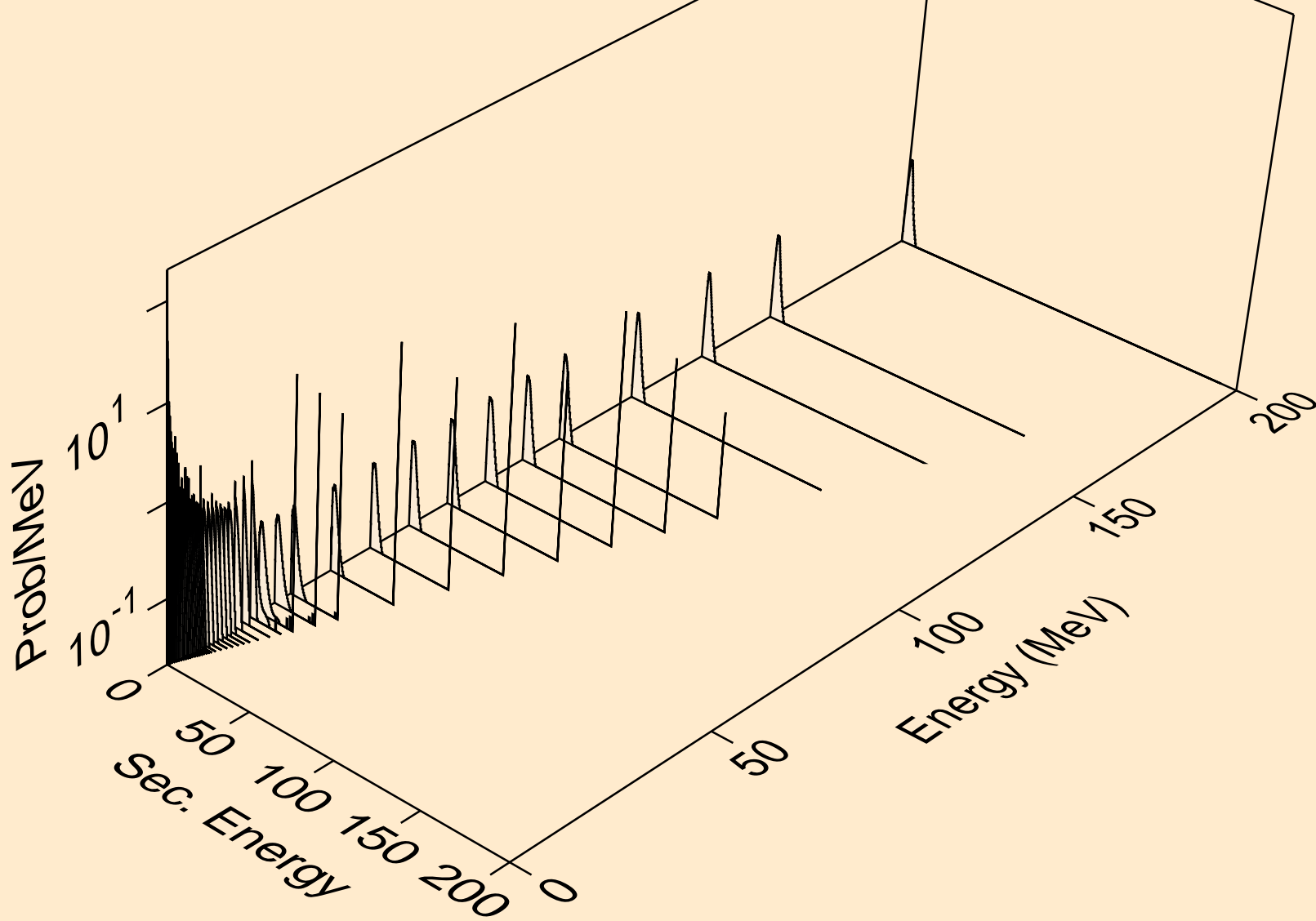

21-SC-45 FOR FENDL-3.1 FROM JEFF-3.1.1 WITH NJOY2012.50+  
Neutron emission for (n,2n)

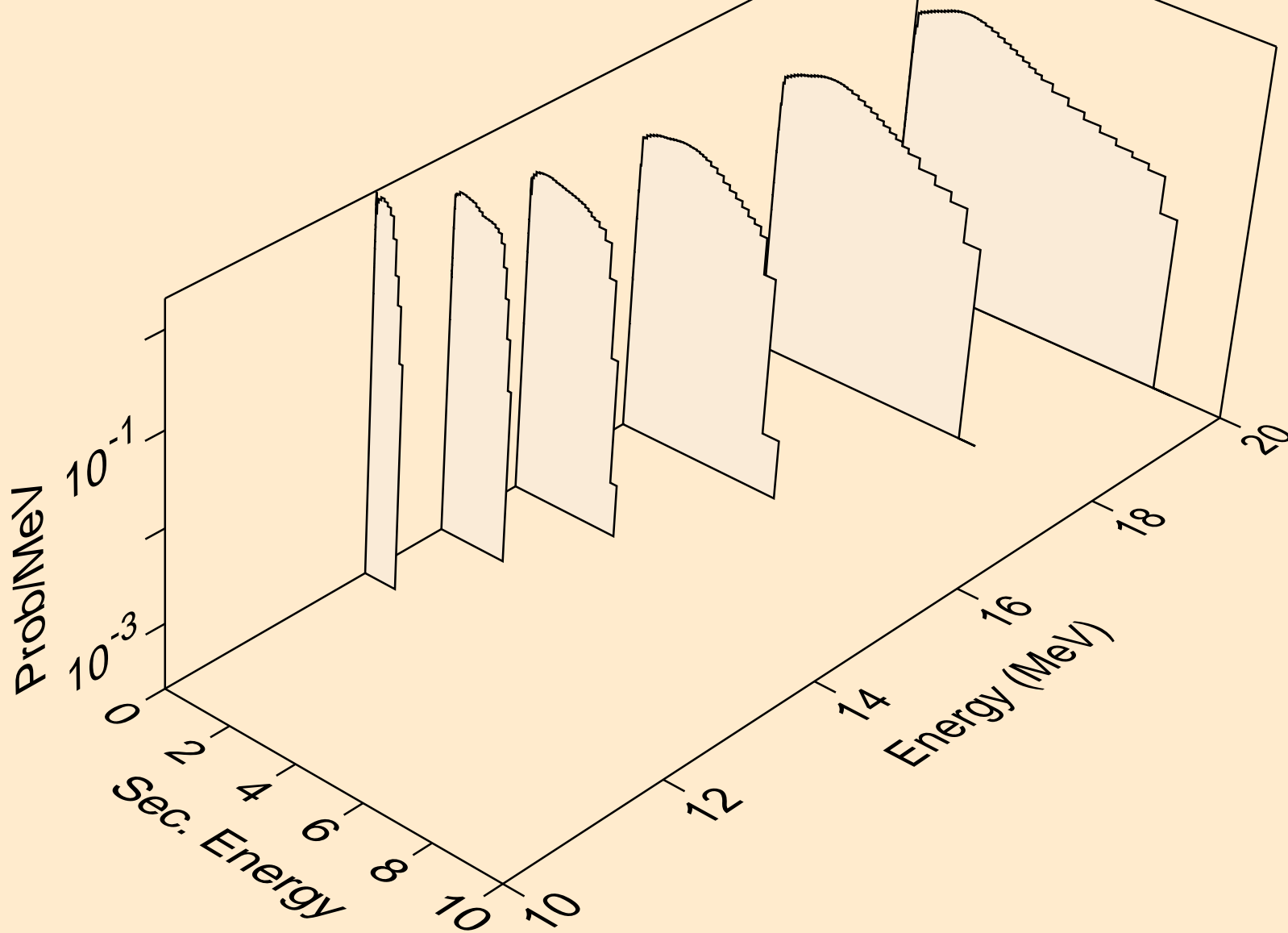

21-SC-45 FOR FENDL-3.1 FROM JEFF-3.1.1 WITH NJOY2012.50+  
Neutron emission for (n,n\*)a

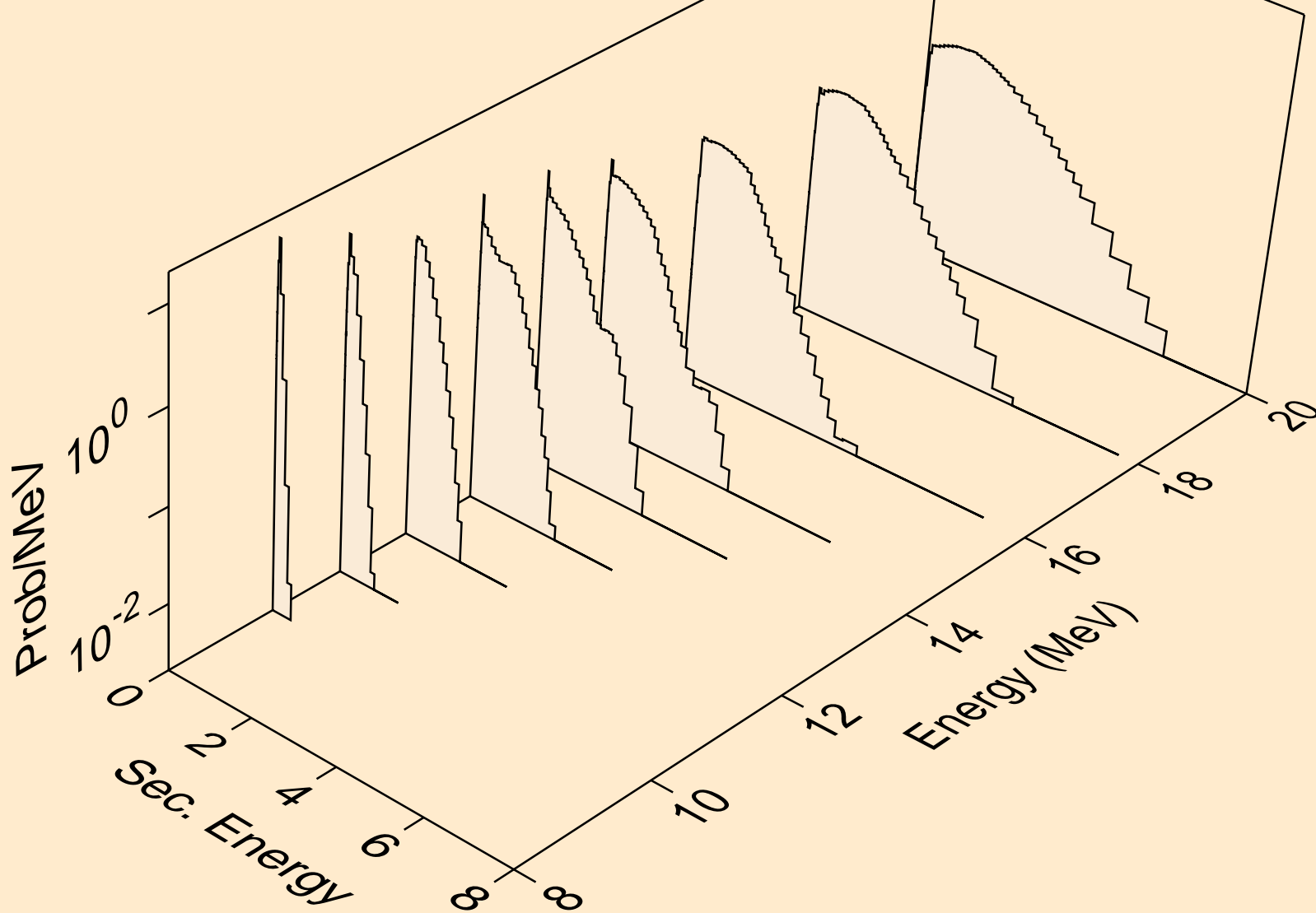

21-SC-45 FOR FENDL-3.1 FROM JEFF-3.1.1 WITH NJOY2012.50+  
Neutron emission for (n,n\*)p

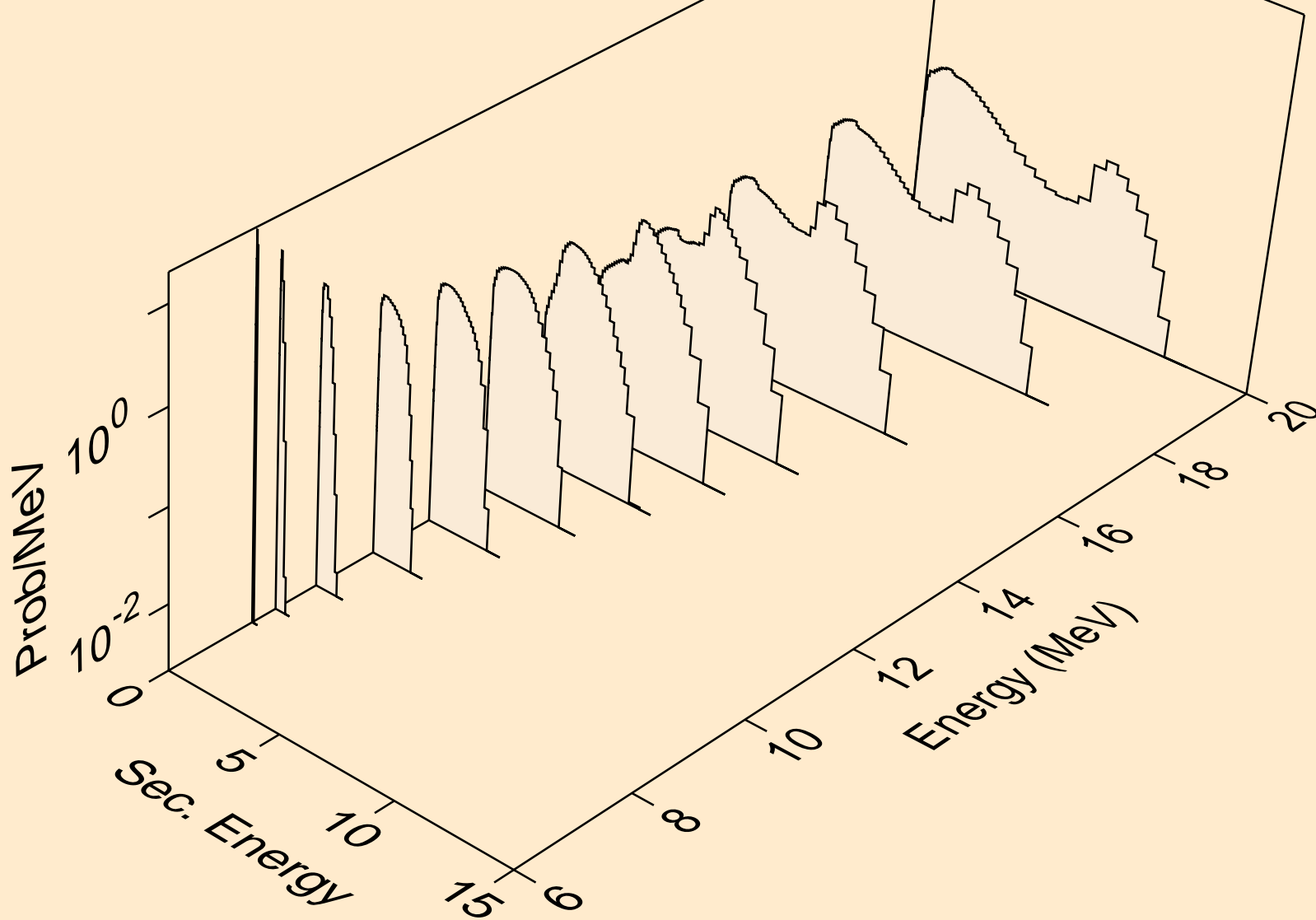

21-SC-45 FOR FENDL-3.1 FROM JEFF-3.1.1 WITH NJOY2012.50+  
Neutron emission for (n,n\*)d

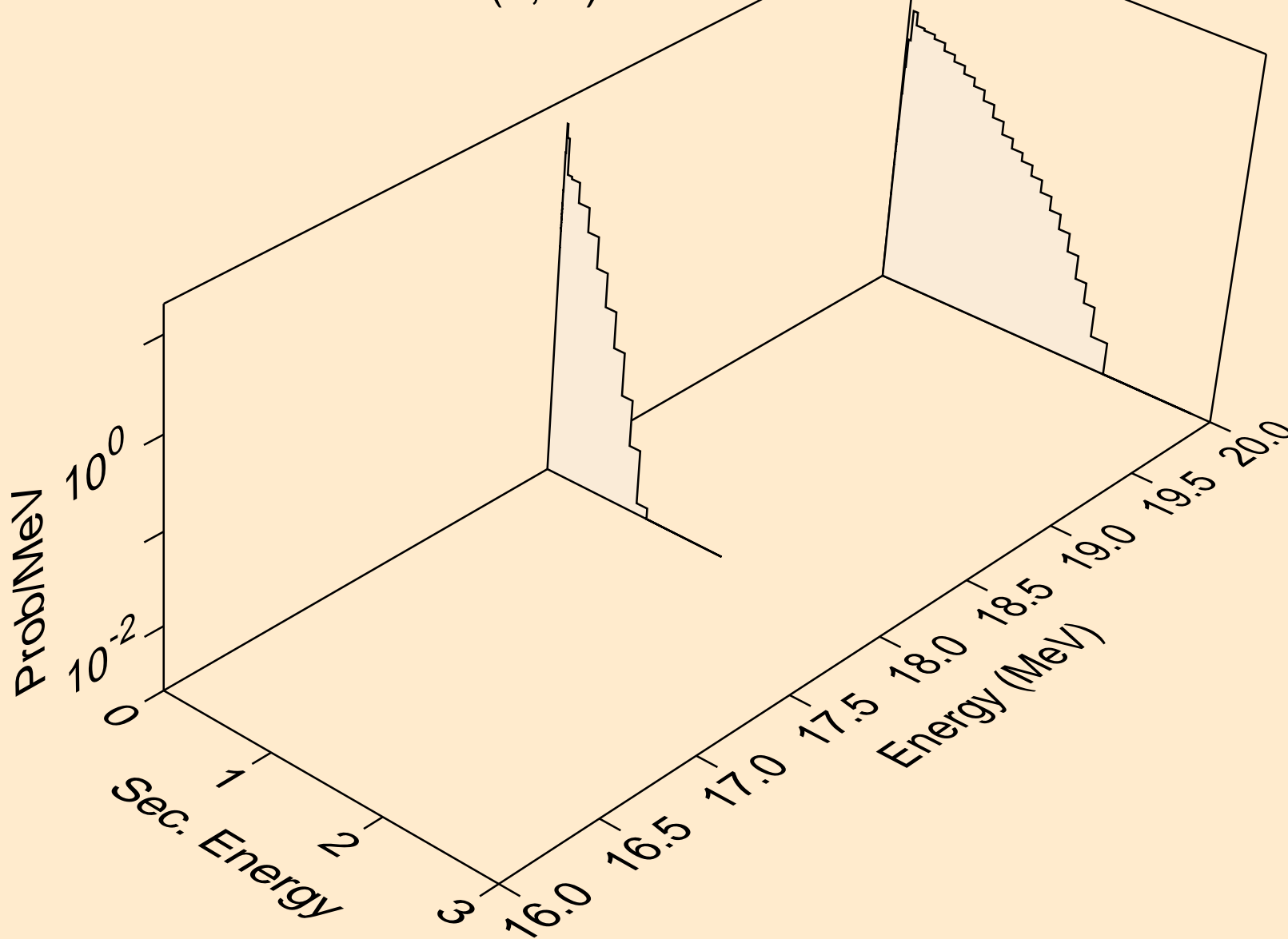

21-SC-45 FOR FENDL-3.1 FROM JEFF-3.1.1 WITH NJOY2012.50+  
Neutron emission for (n,n\*)t

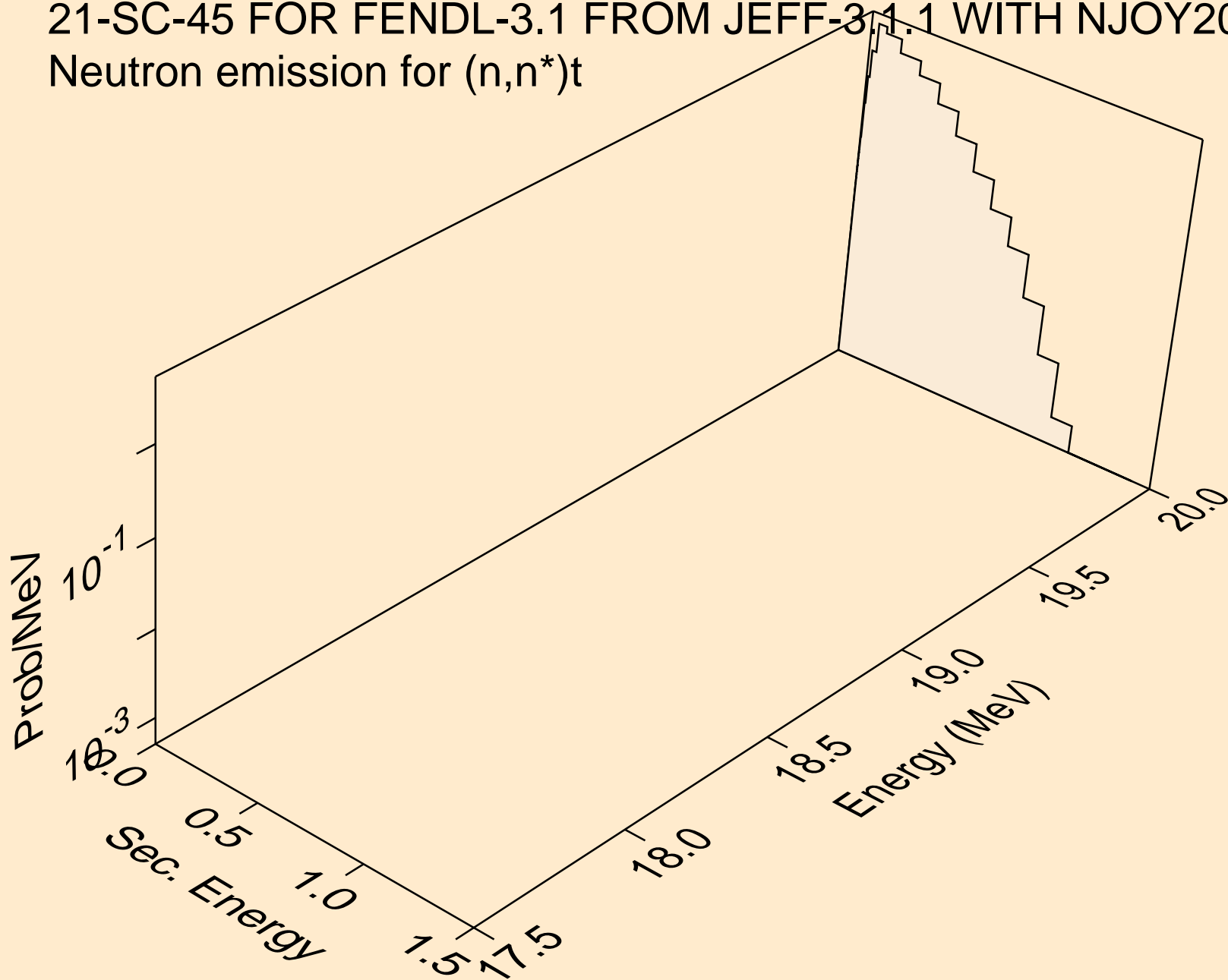



21-SC-45 FOR FENDL-3.1 FROM JEFF-3.1.1 WITH NJOY2012.50+  
Neutron emission for (n,2np)

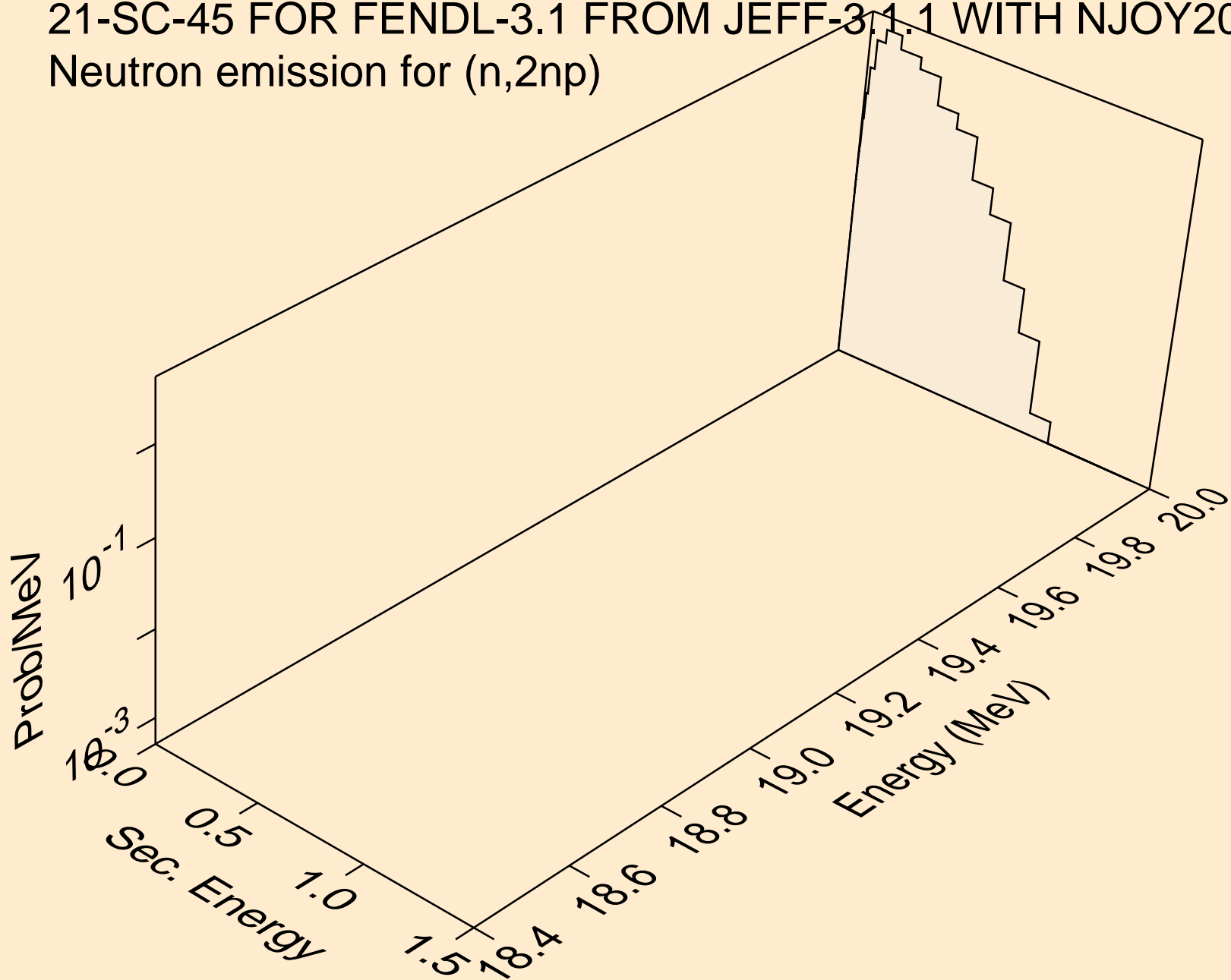

21-SC-45 FOR FENDL-3.1 FROM JEFF-3.1.1 WITH NJOY2012.50+  
Neutron emission for (n,n\*c)

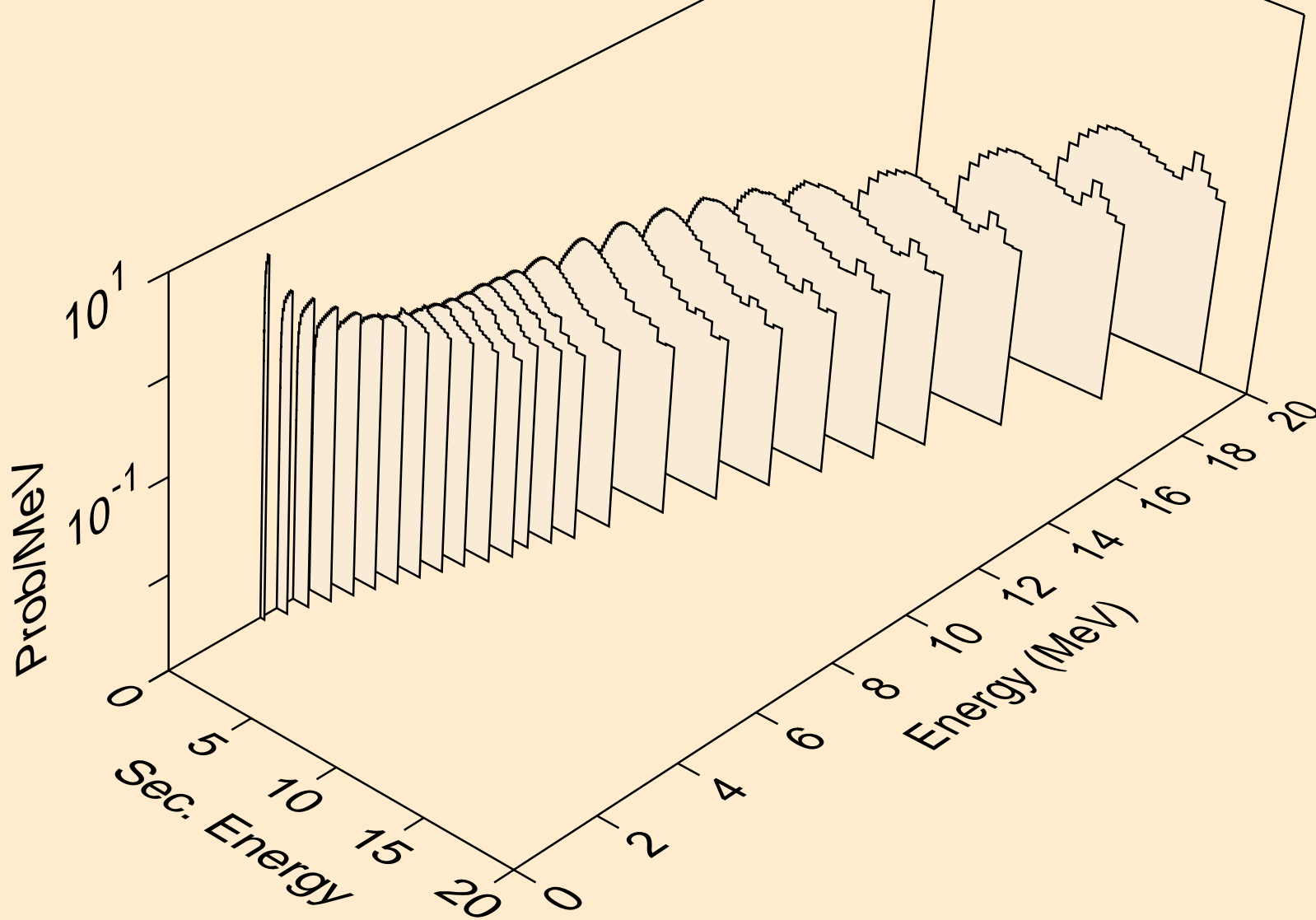

21-SC-45 FOR FENDL-3.1 FROM JEFF-3.1.1 WITH NJOY2012.50+  
Photon emission for (n,x)

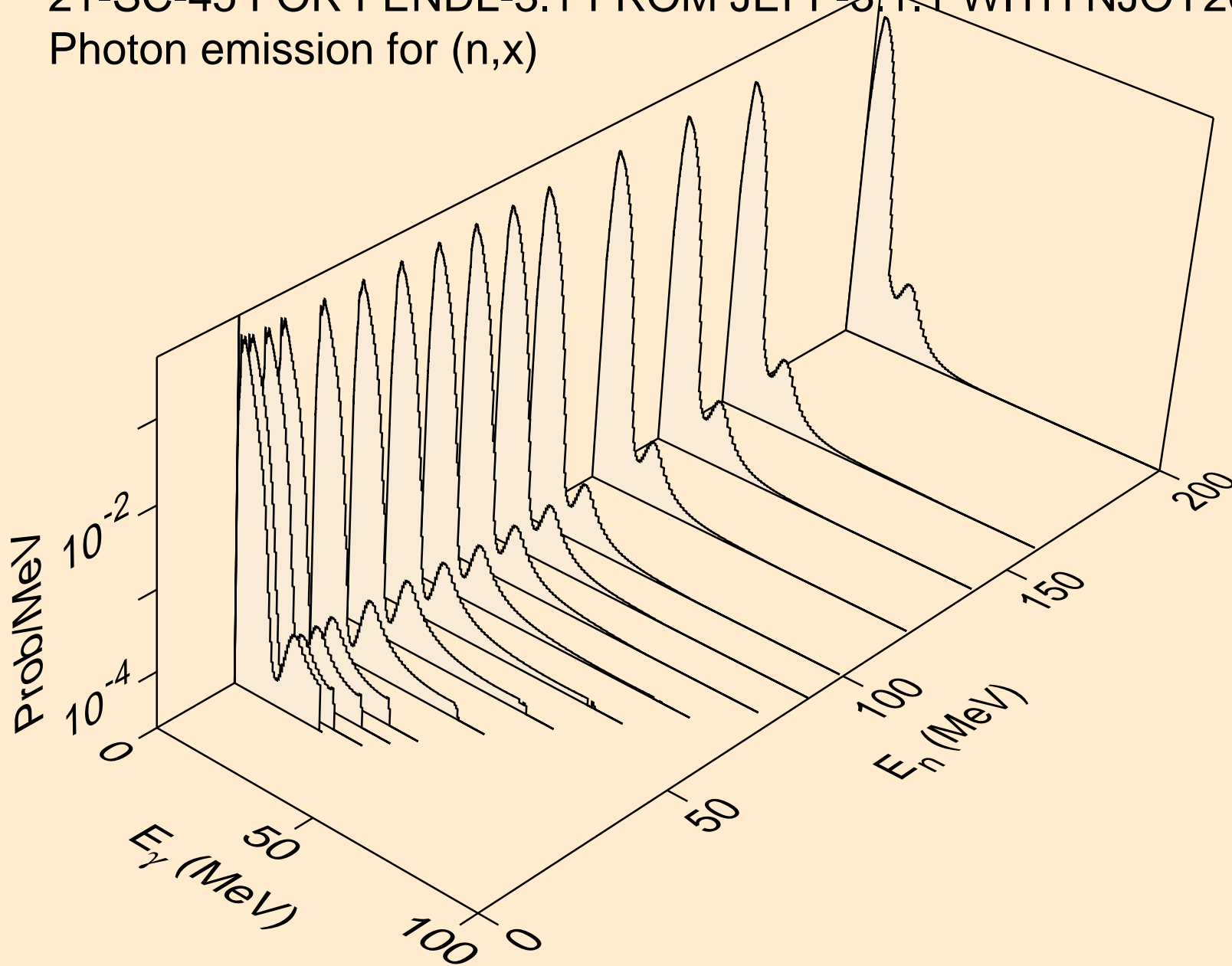

21-SC-45 FOR FENDL-3.1 FROM JEFF-3.1.1 WITH NJOY2012.50+  
Photon emission for (n,2n)

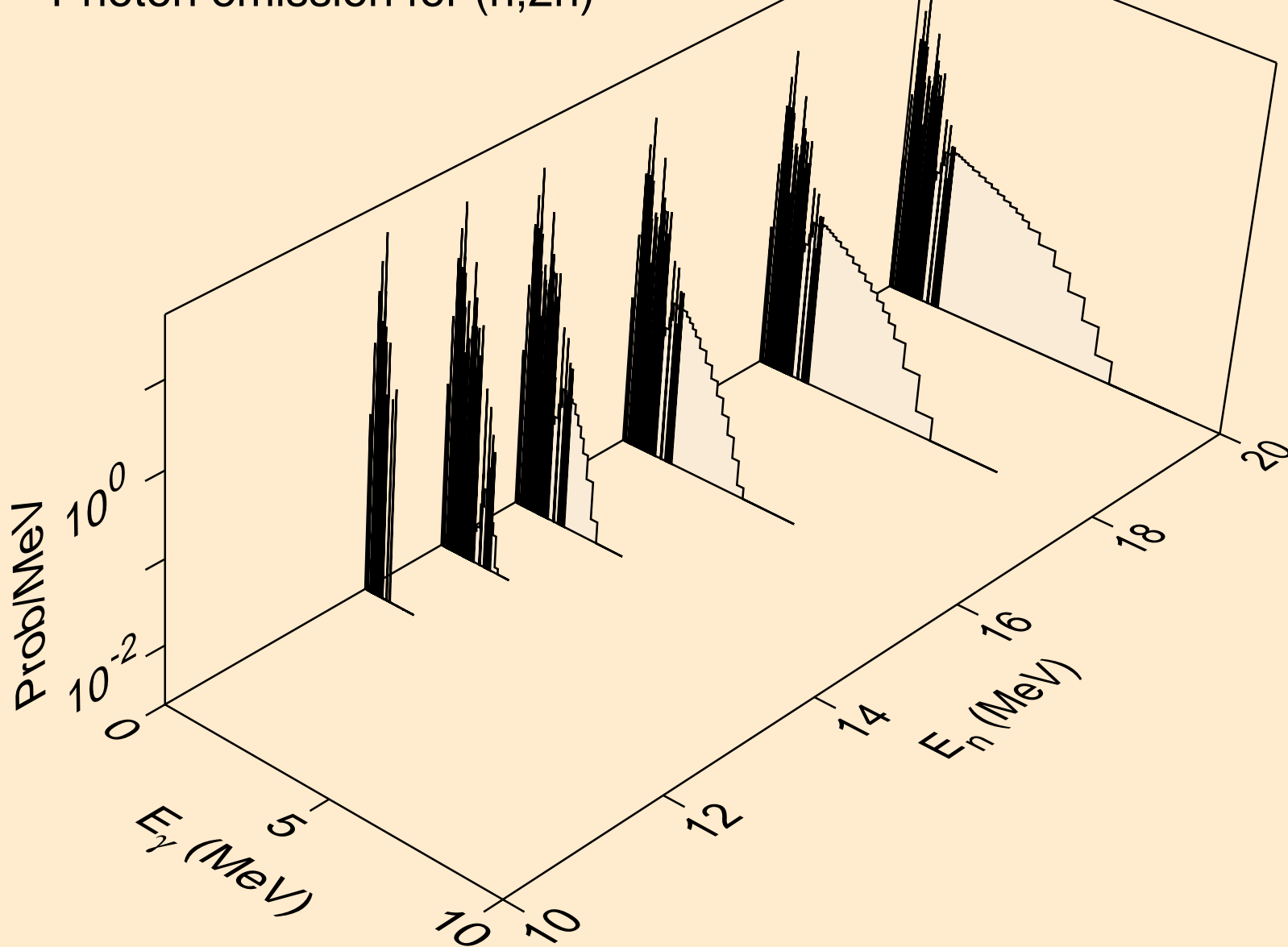

21-SC-45 FOR FENDL-3.1 FROM JEFF-3.1.1 WITH NJOY2012.50+  
Photon emission for (n,n\*)a

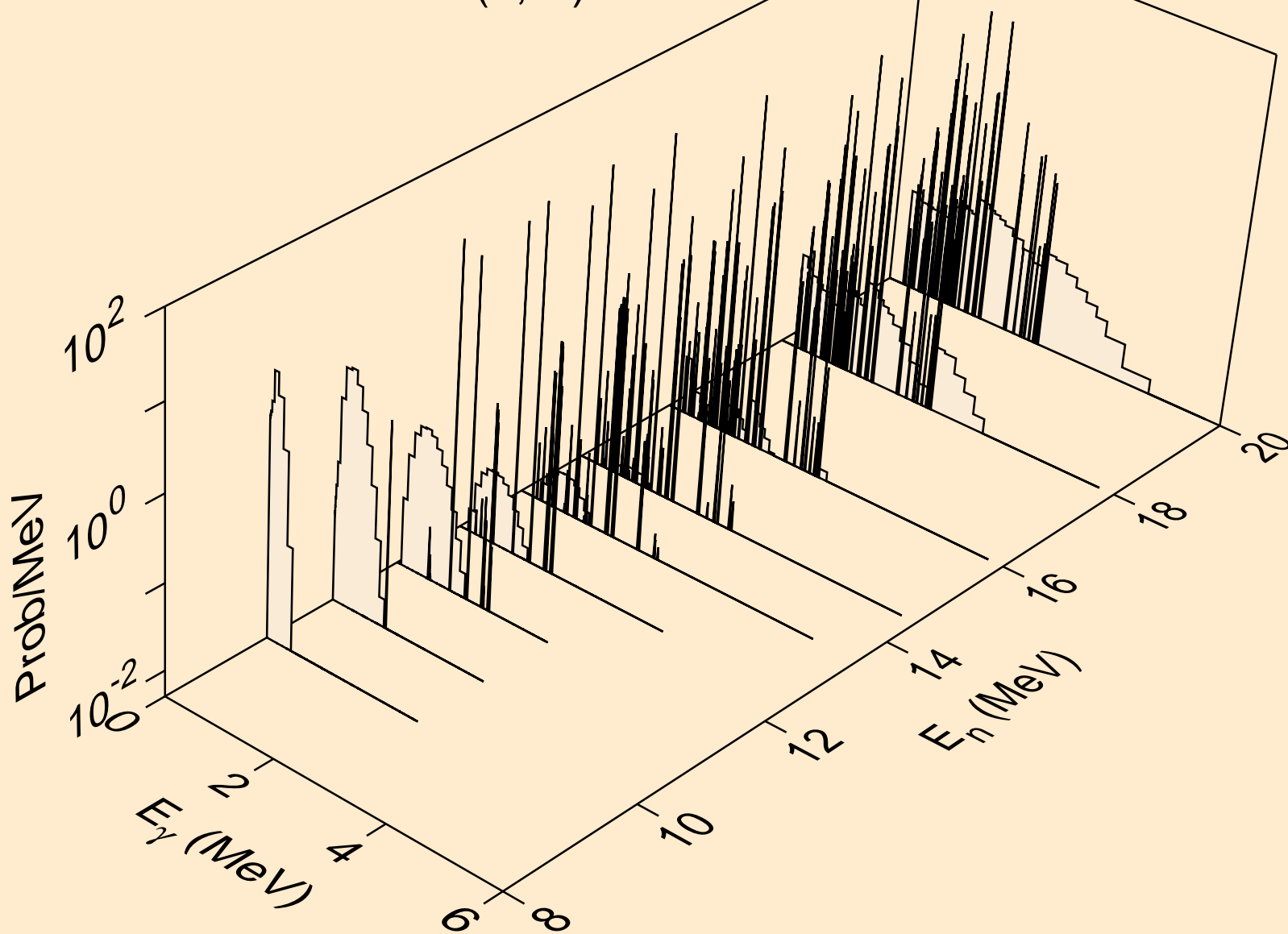

21-SC-45 FOR FENDL-3.1 FROM JEFF-3.1.1 WITH NJOY2012.50+  
Photon emission for (n,n\*)p

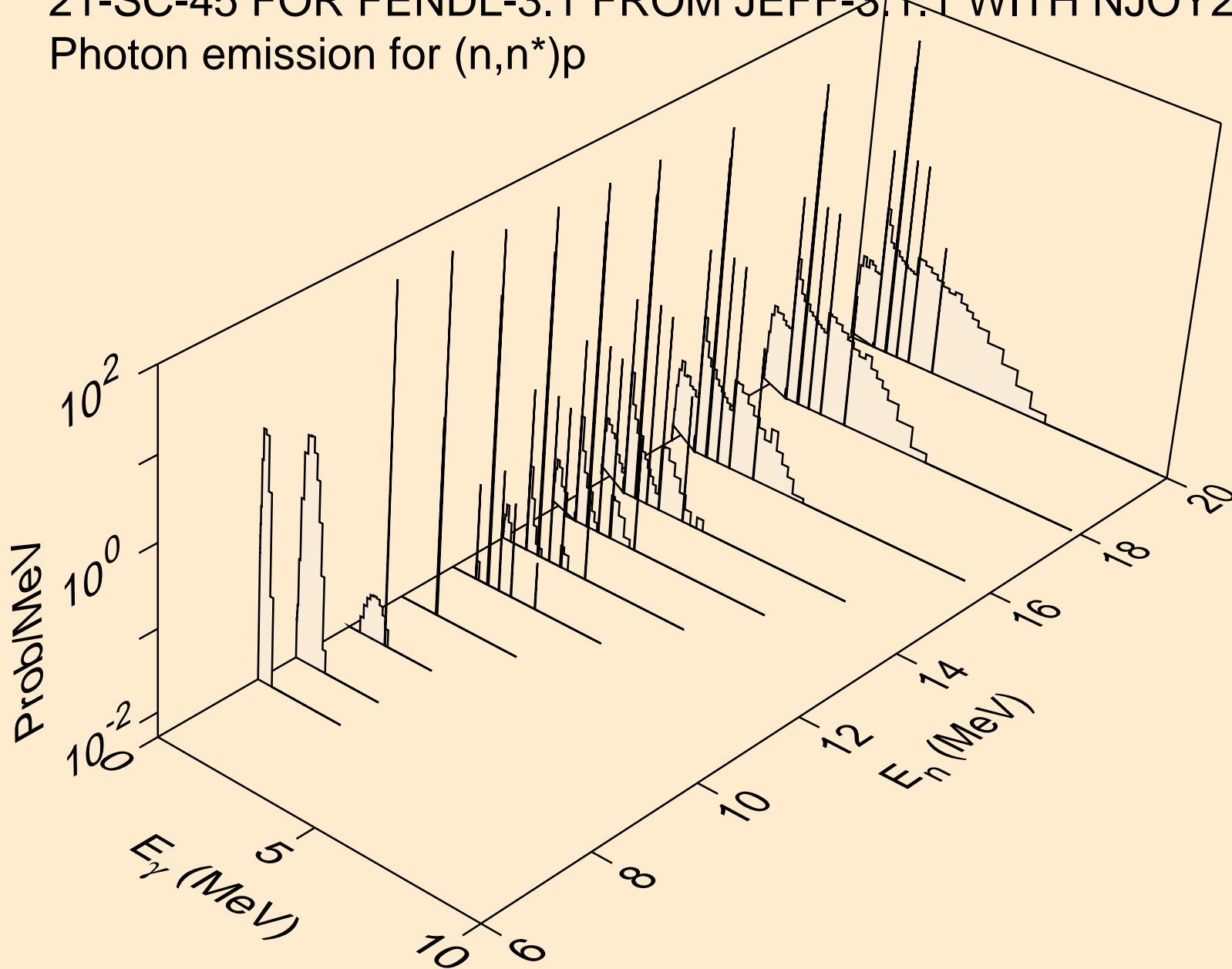

21-SC-45 FOR FENDL-3.1 FROM JEFF-3.1.1 WITH NJOY2012.50+  
Photon emission for (n,n\*)d

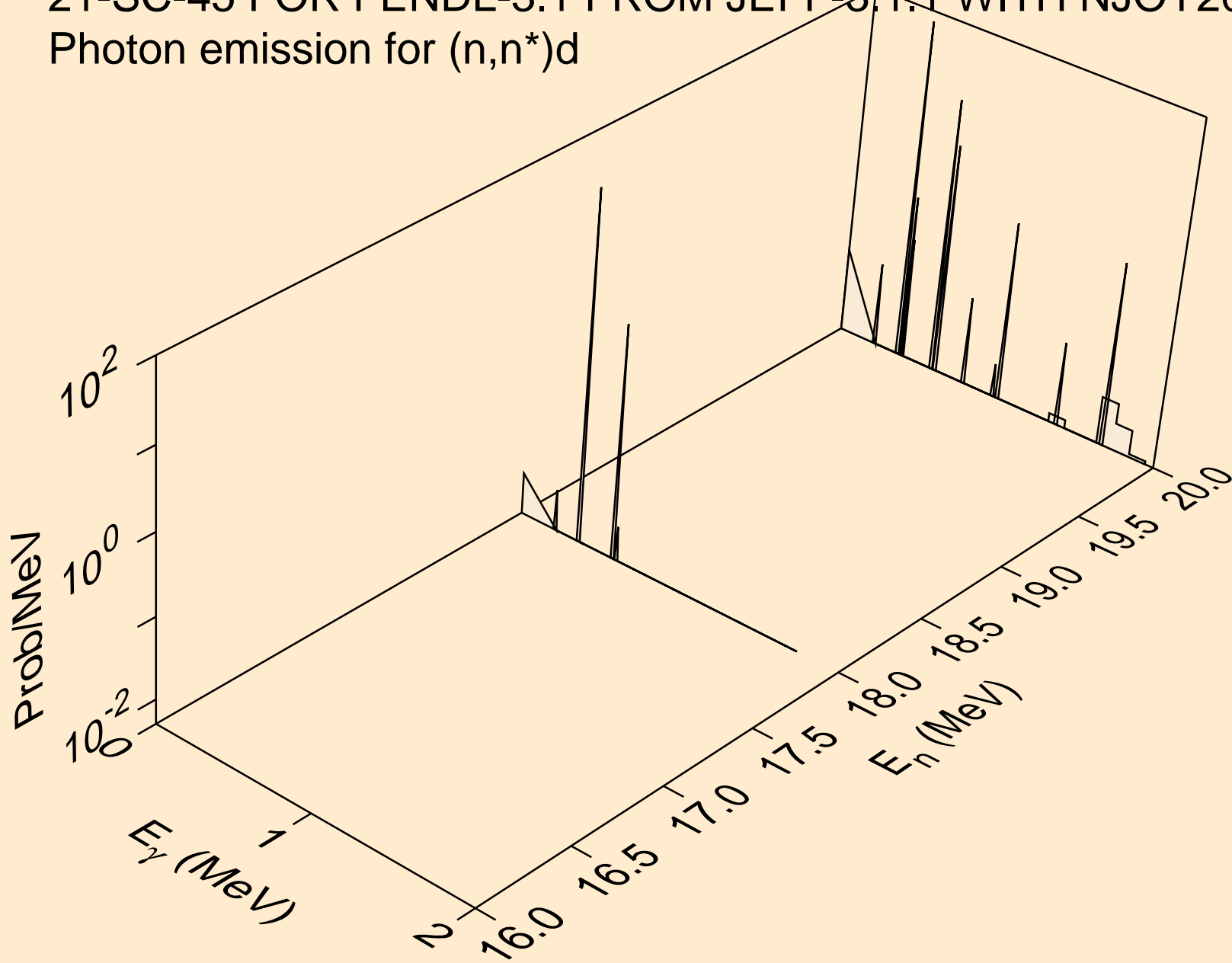

21-SC-45 FOR FENDL-3.1 FROM JEFF-3.1.1 WITH NJOY2012.50+  
Photon emission for (n,n\*)t

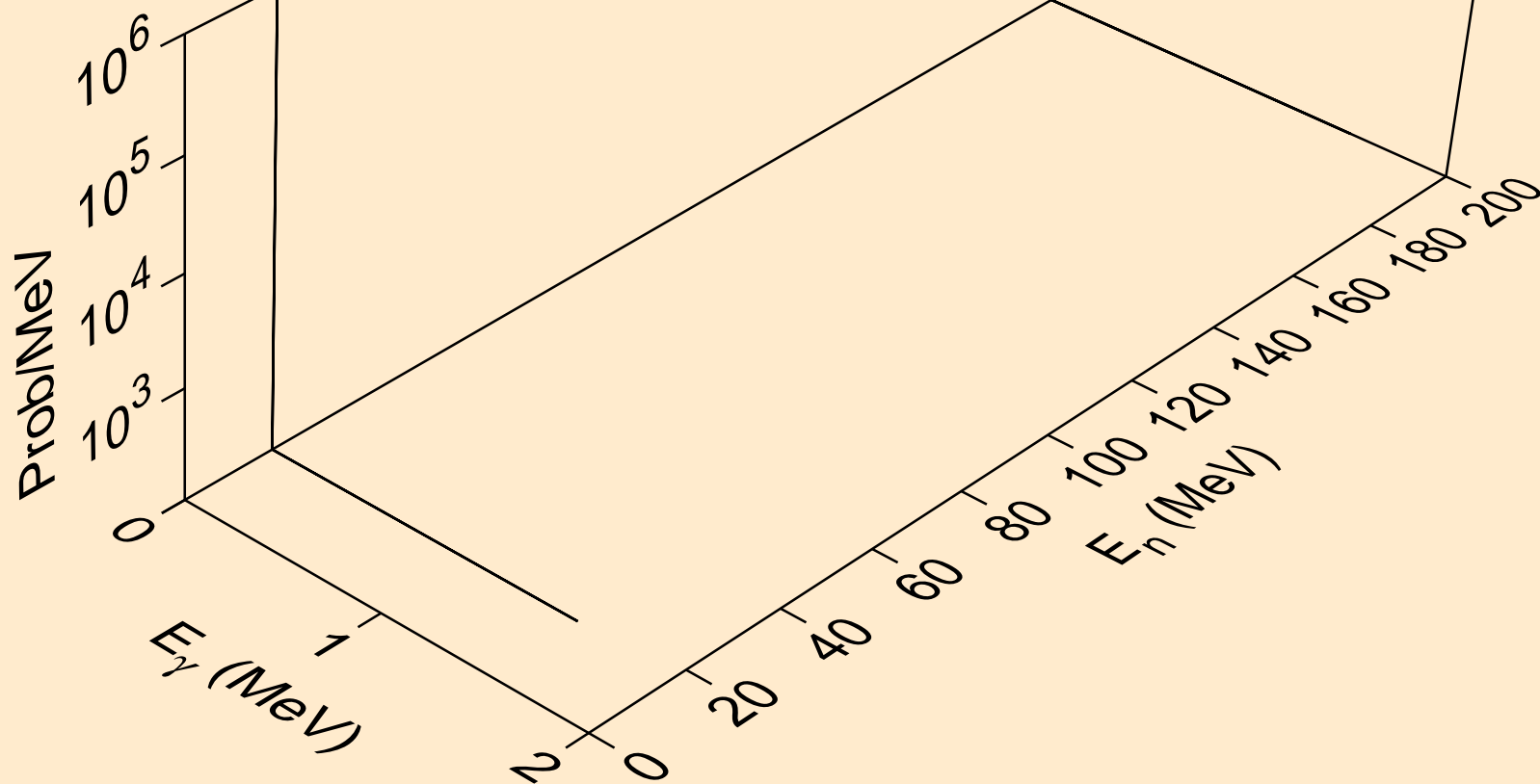



21-SC-45 FOR FENDL-3.1 FROM JEFF-3.1.1 WITH NJOY2012.50+  
Photon emission for (n,2np)

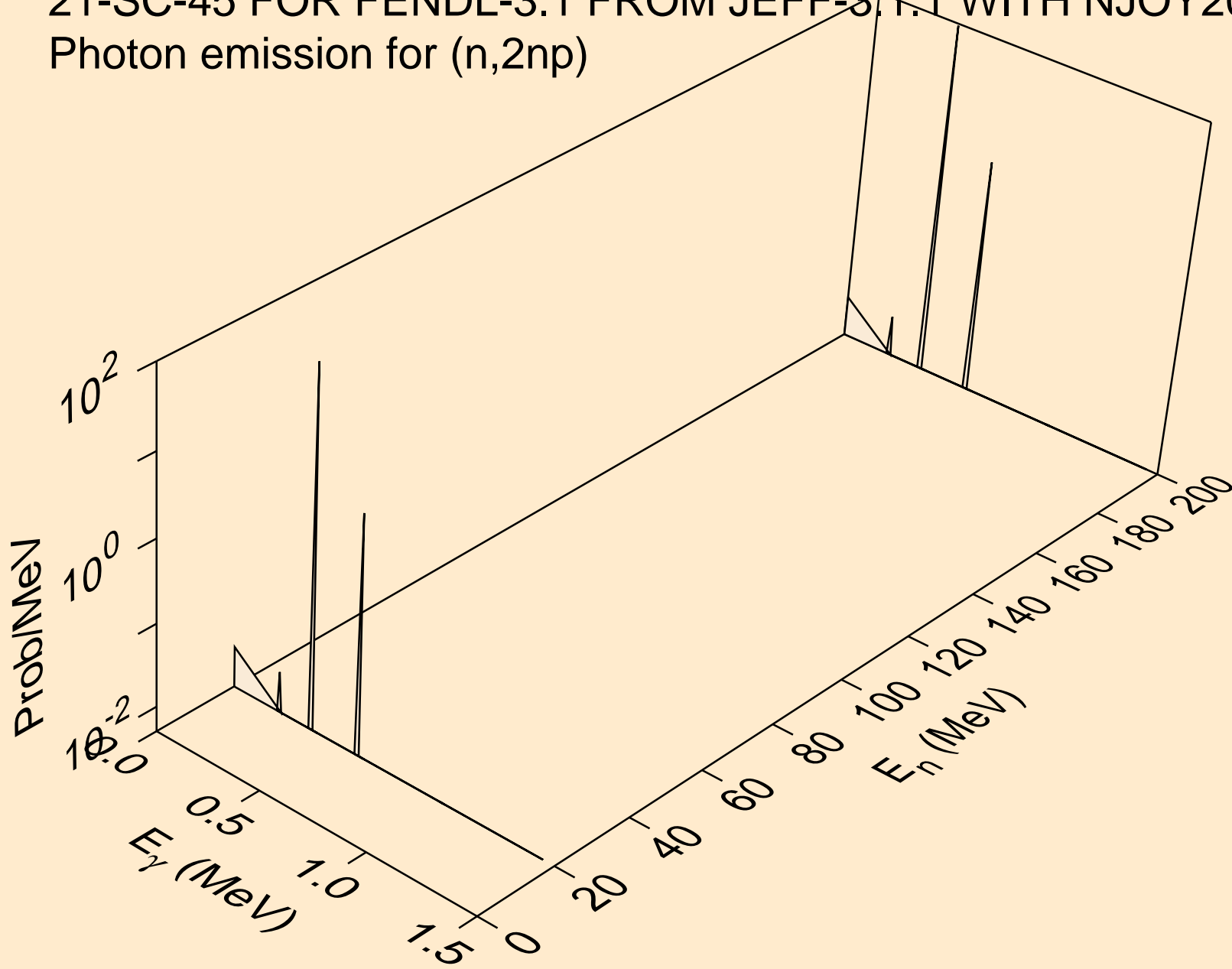

21-SC-45 FOR FENDL-3.1 FROM JEFF-3.1.1 WITH NJOY2012.50+  
Photon emission for (n,n\*1)

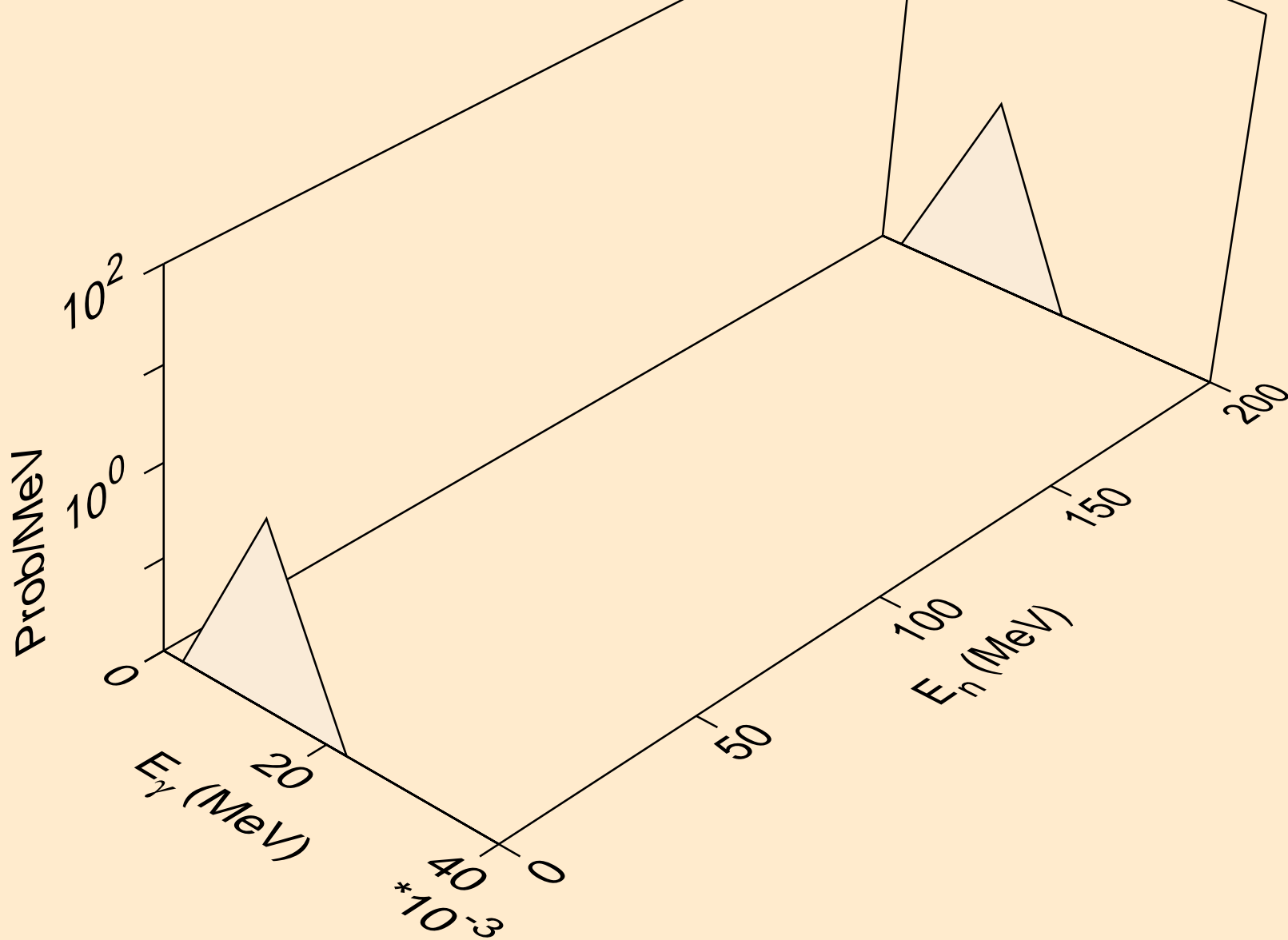

21-SC-45 FOR FENDL-3.1 FROM JEFF-3.1.1 WITH NJOY2012.50+  
Photon emission for (n,n\*2)

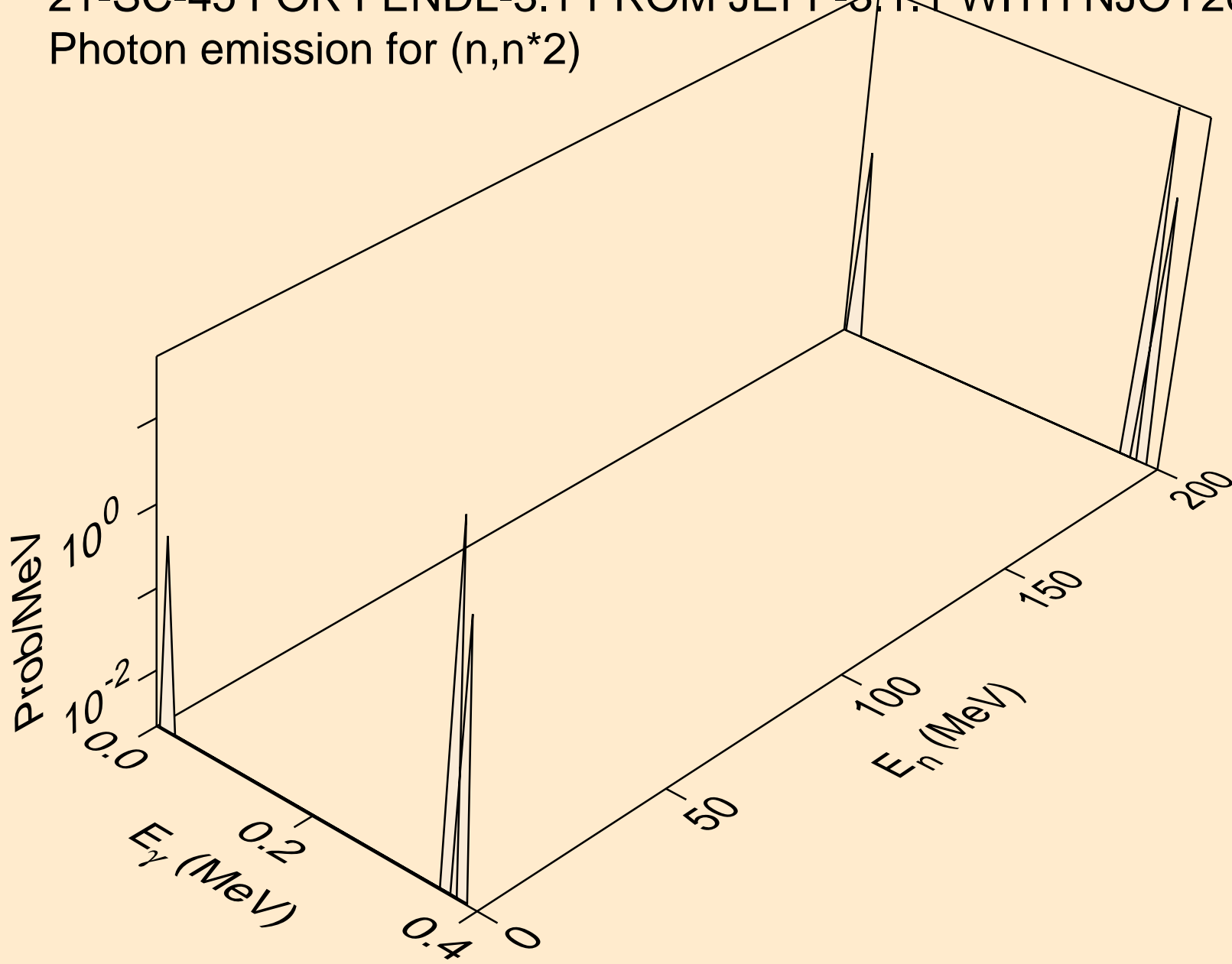

21-SC-45 FOR FENDL-3.1 FROM JEFF-3.1.1 WITH NJOY2012.50+  
Photon emission for (n,n\*3)

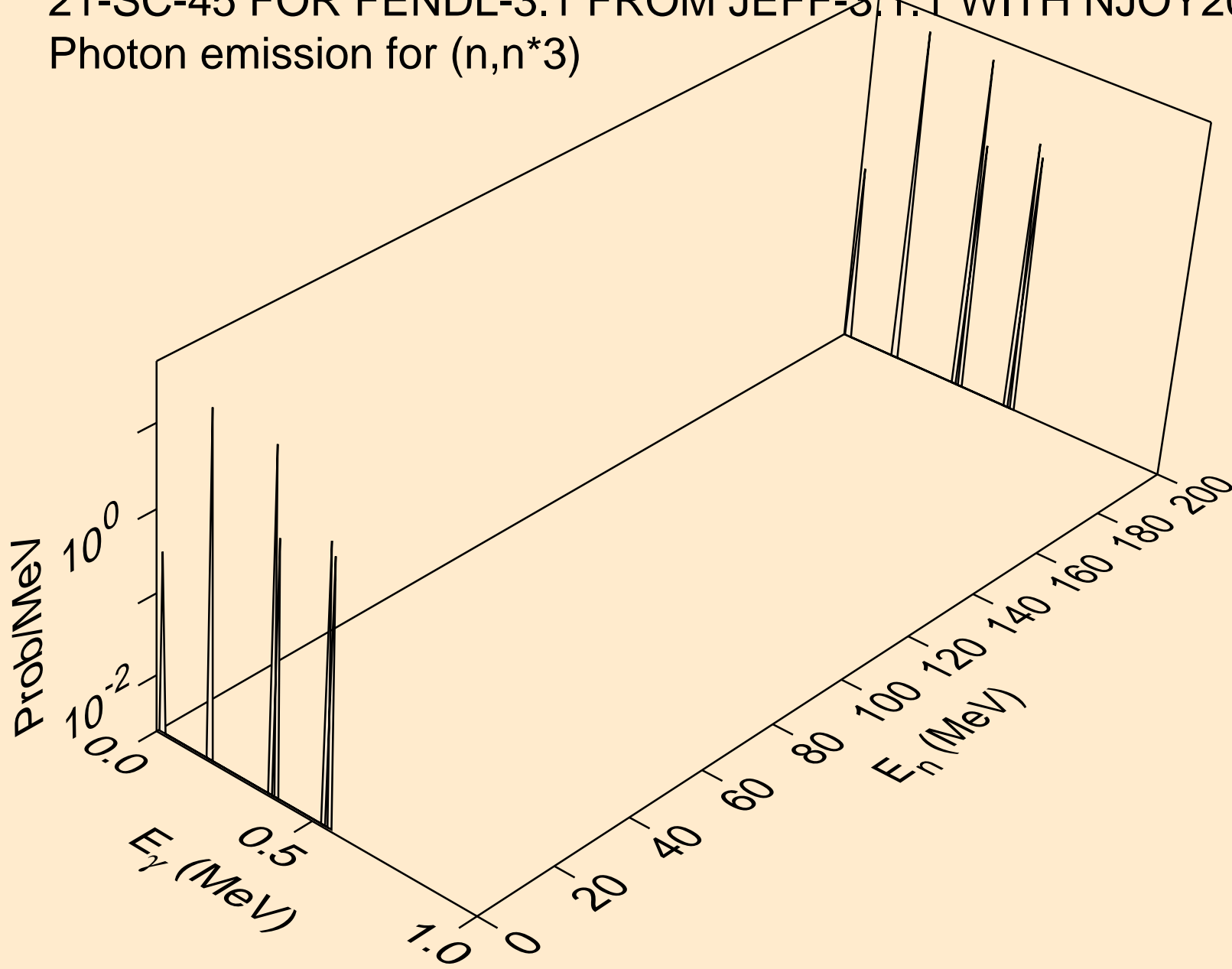

21-SC-45 FOR FENDL-3.1 FROM JEFF-3.1.1 WITH NJOY2012.50+  
Photon emission for (n,n\*4)

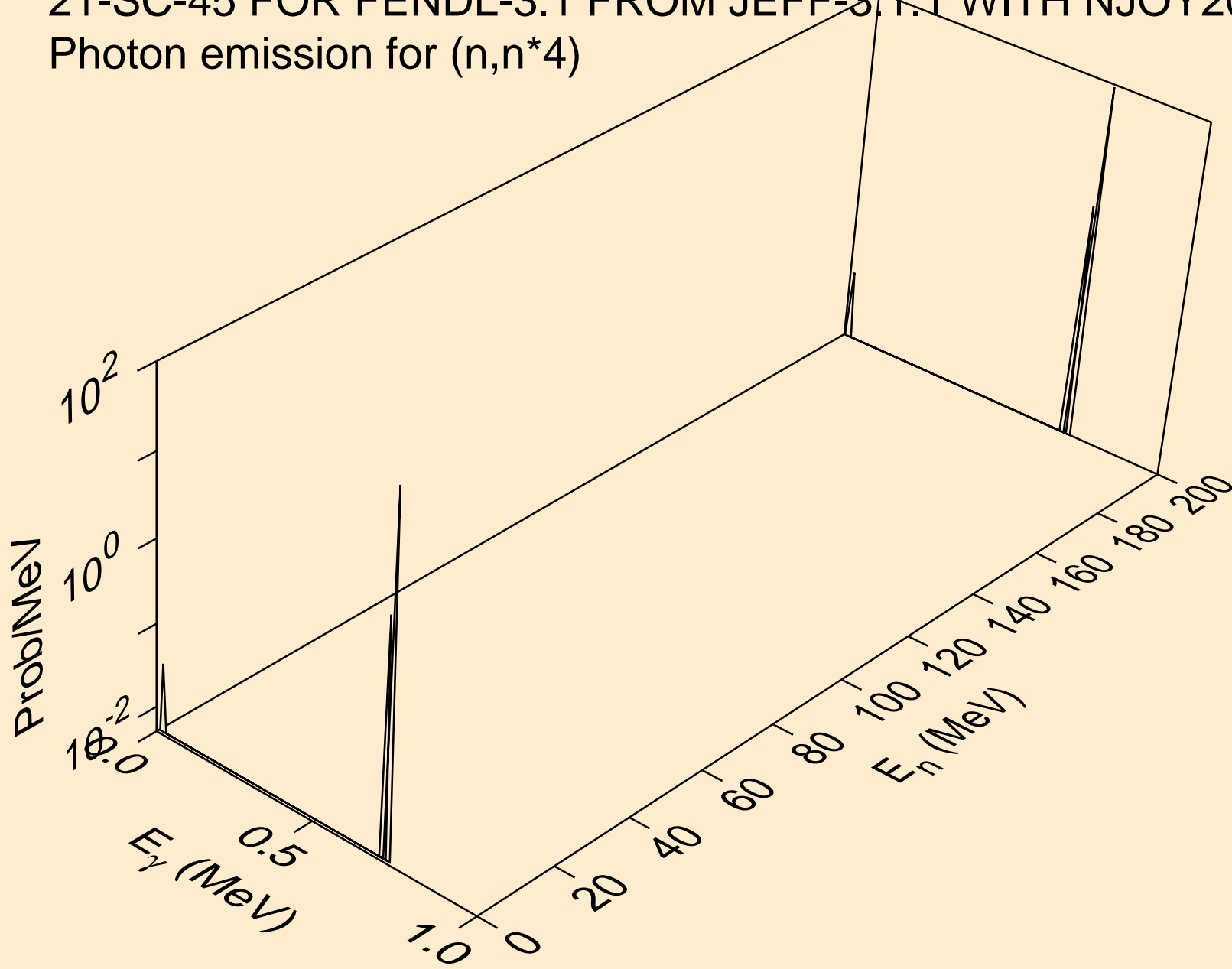

21-SC-45 FOR FENDL-3.1 FROM JEFF-3.1.1 WITH NJOY2012.50+  
Photon emission for (n,n\*5)

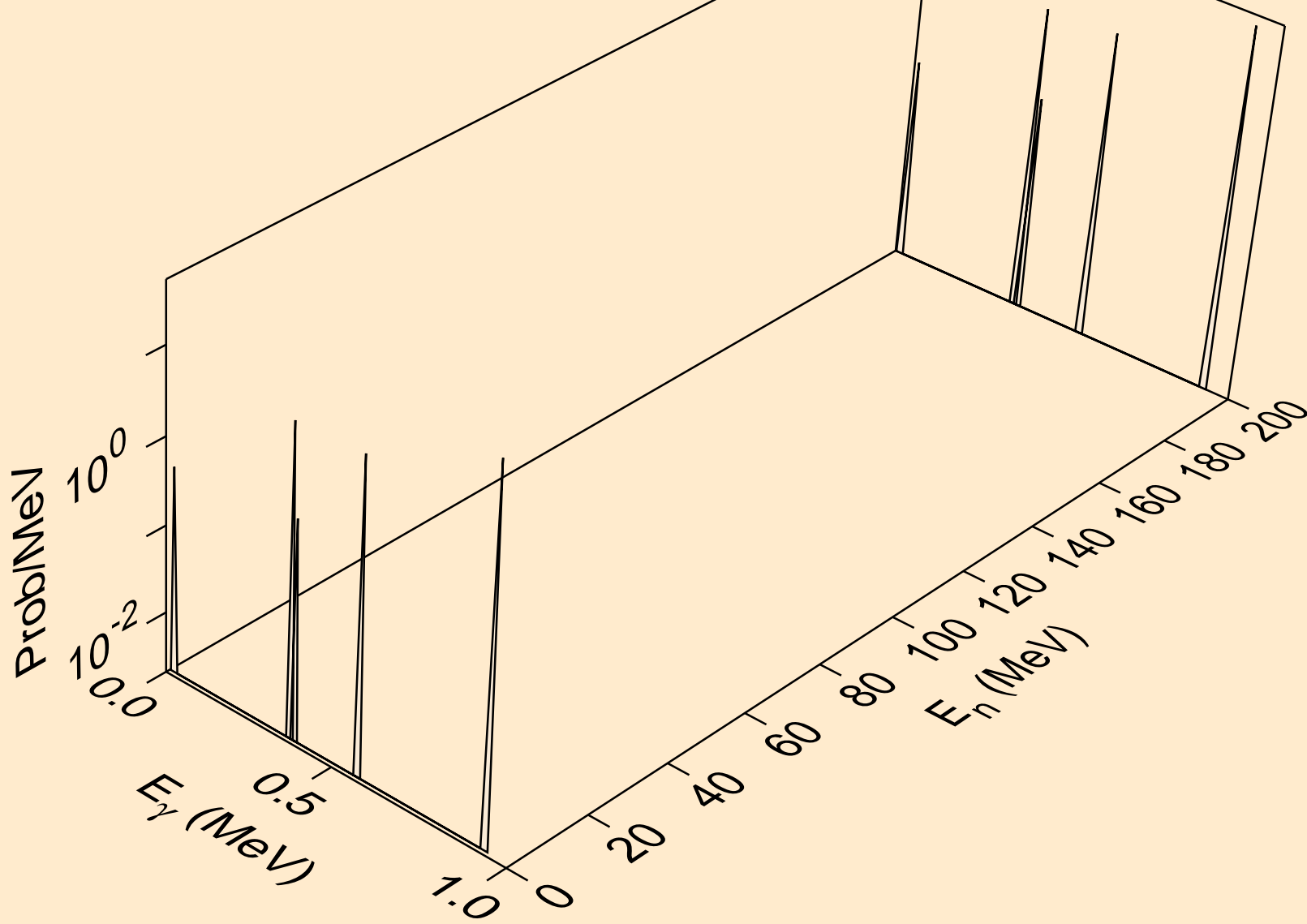

21-SC-45 FOR FENDL-3.1 FROM JEFF-3.1.1 WITH NJOY2012.50+  
Photon emission for (n,n\*6)

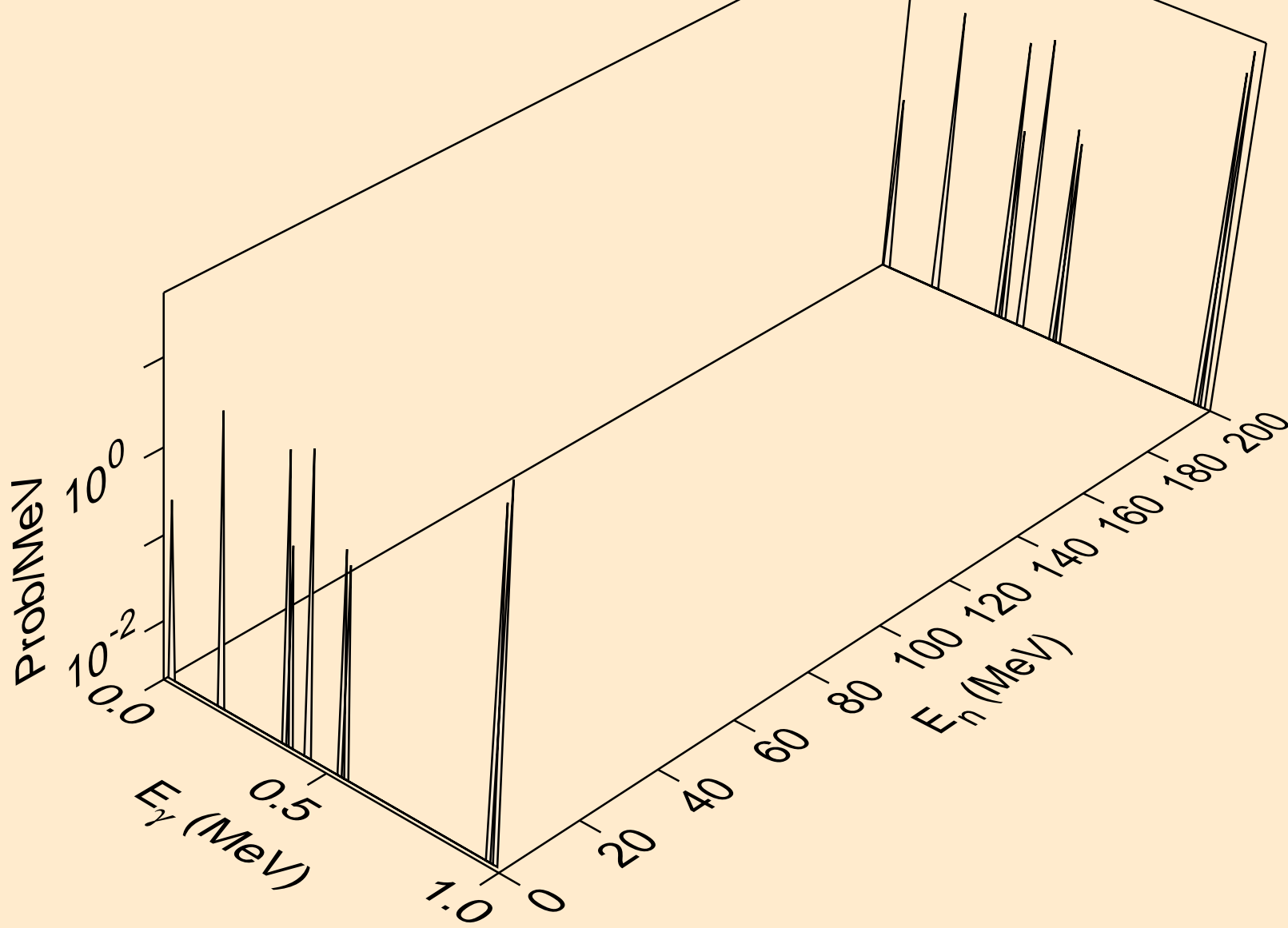

21-SC-45 FOR FENDL-3.1 FROM JEFF-3.1.1 WITH NJOY2012.50+  
Photon emission for (n,n\*7)

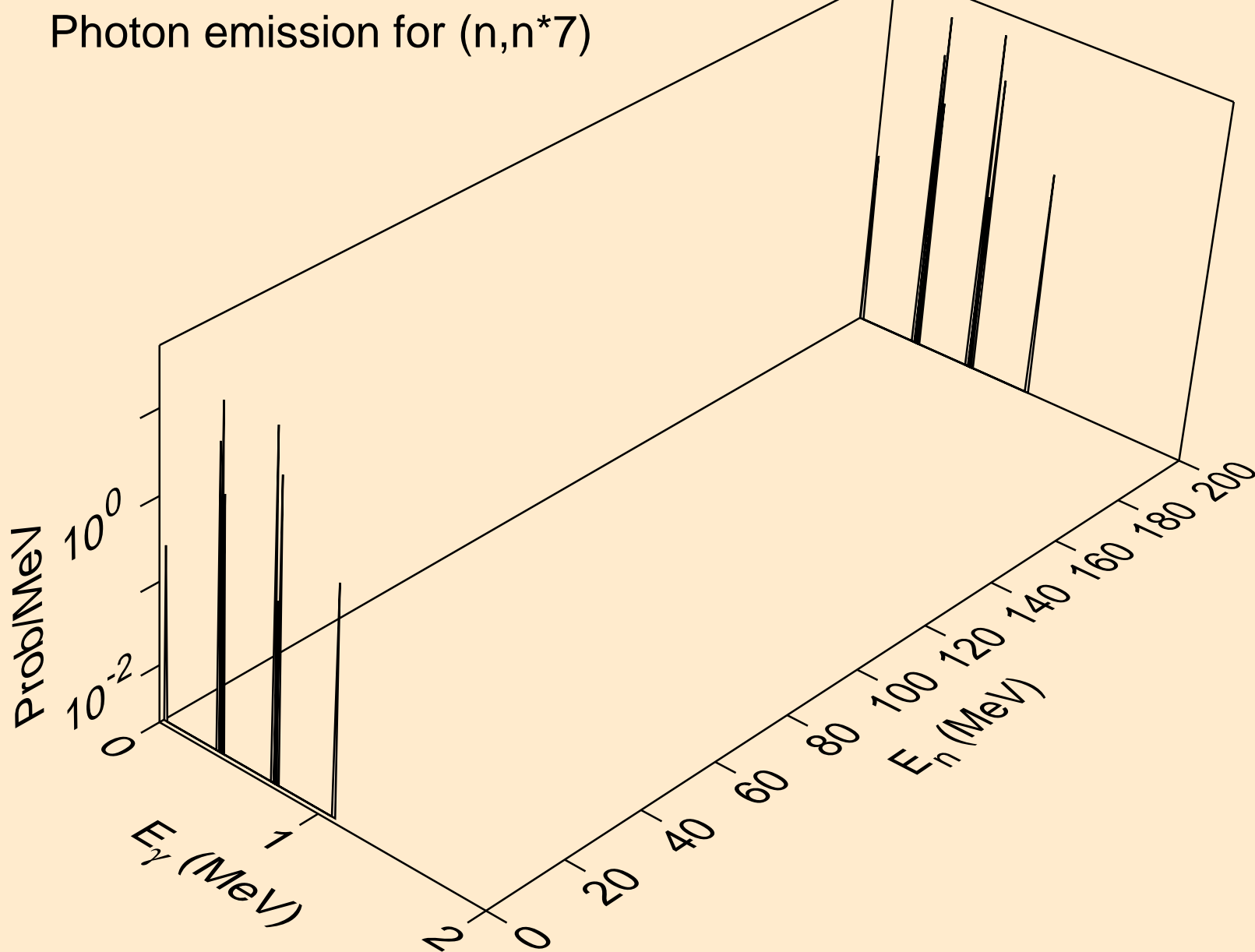



21-SC-45 FOR FENDL-3.1 FROM JEFF-3.1.1 WITH NJOY2012.50+  
Photon emission for (n,n\*8)

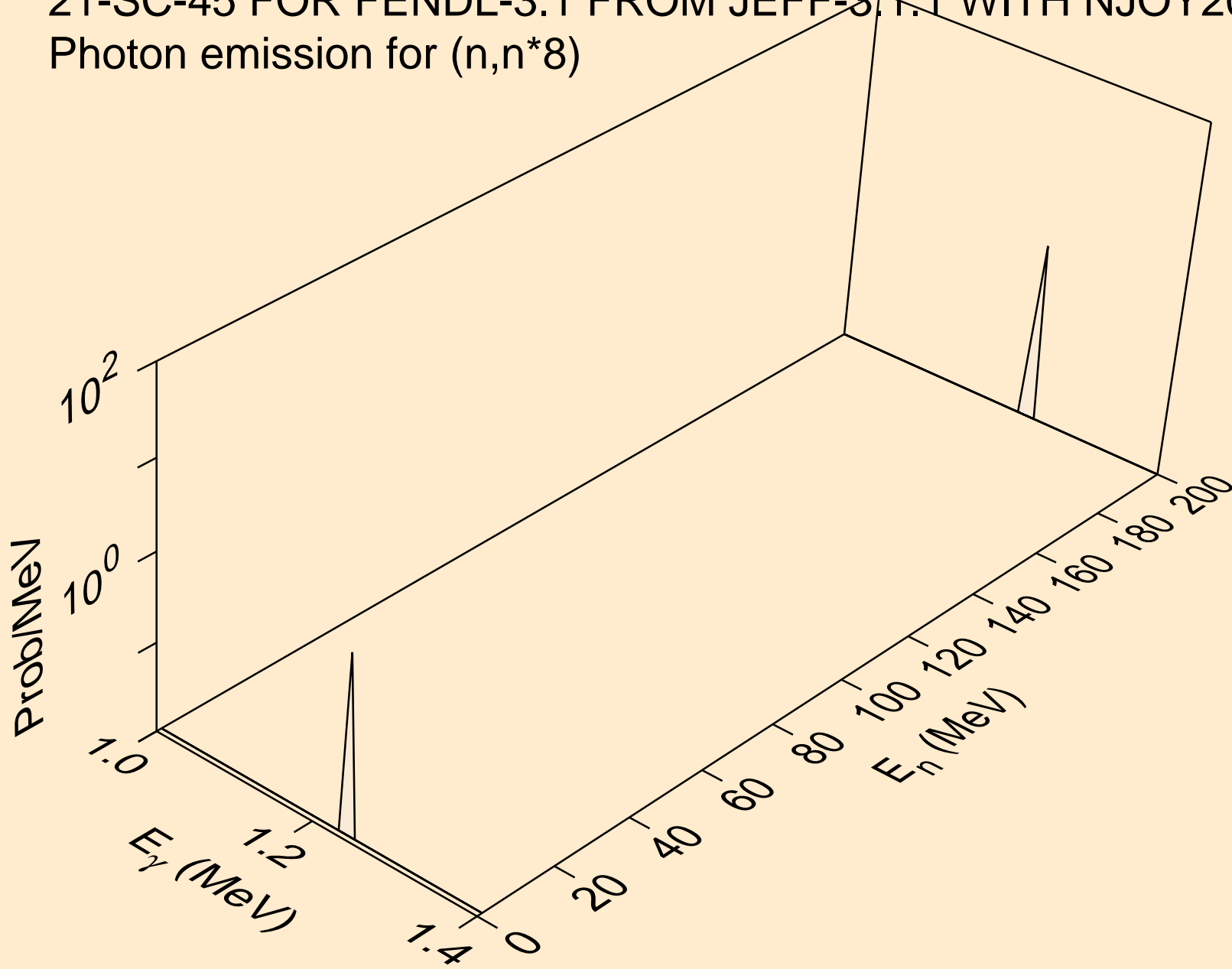

21-SC-45 FOR FENDL-3.1 FROM JEFF-3.1.1 WITH NJOY2012.50+  
Photon emission for (n,n\*9)

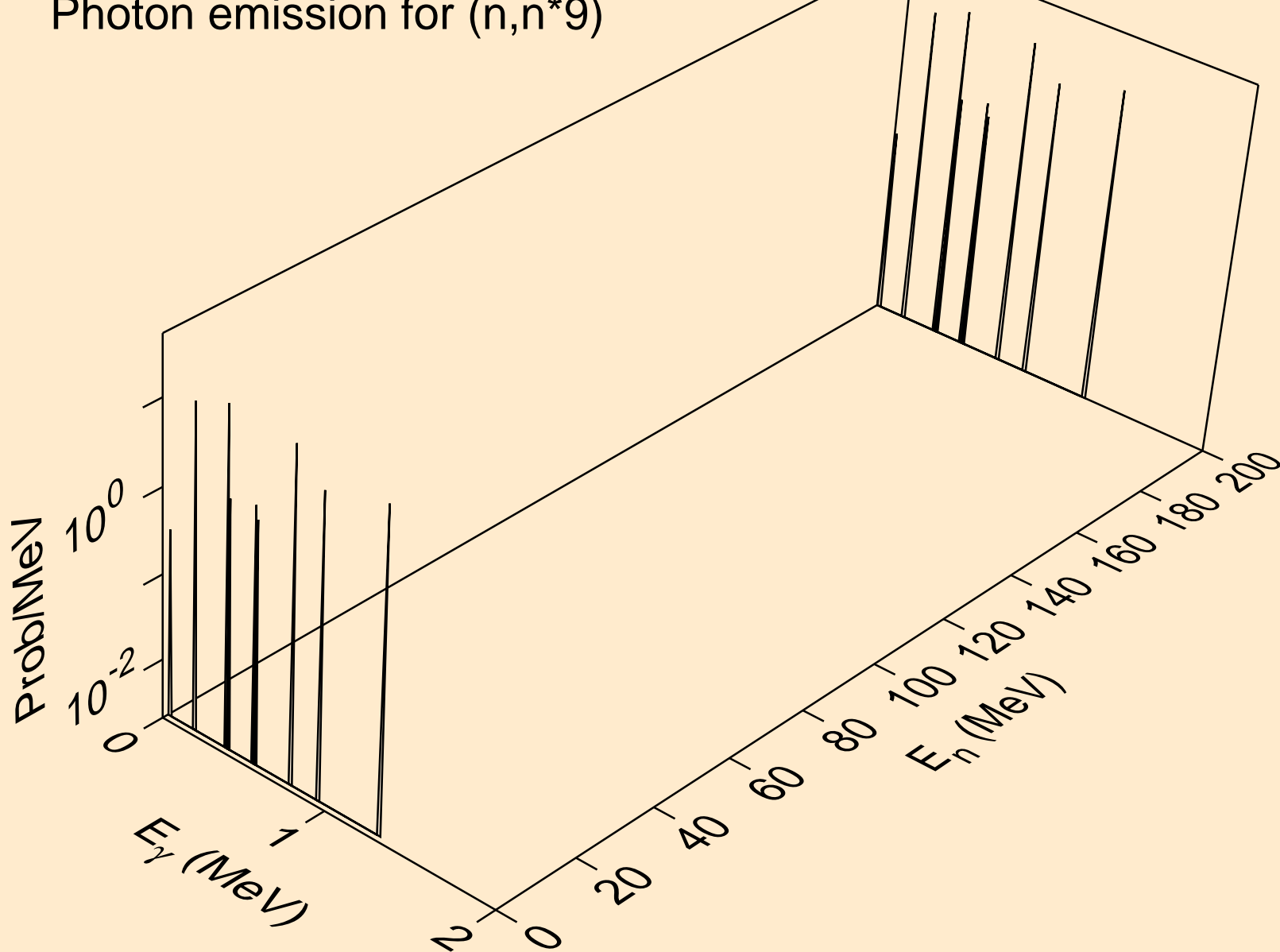

21-SC-45 FOR FENDL-3.1 FROM JEFF-3.1.1 WITH NJOY2012.50+  
Photon emission for (n,n\*10)

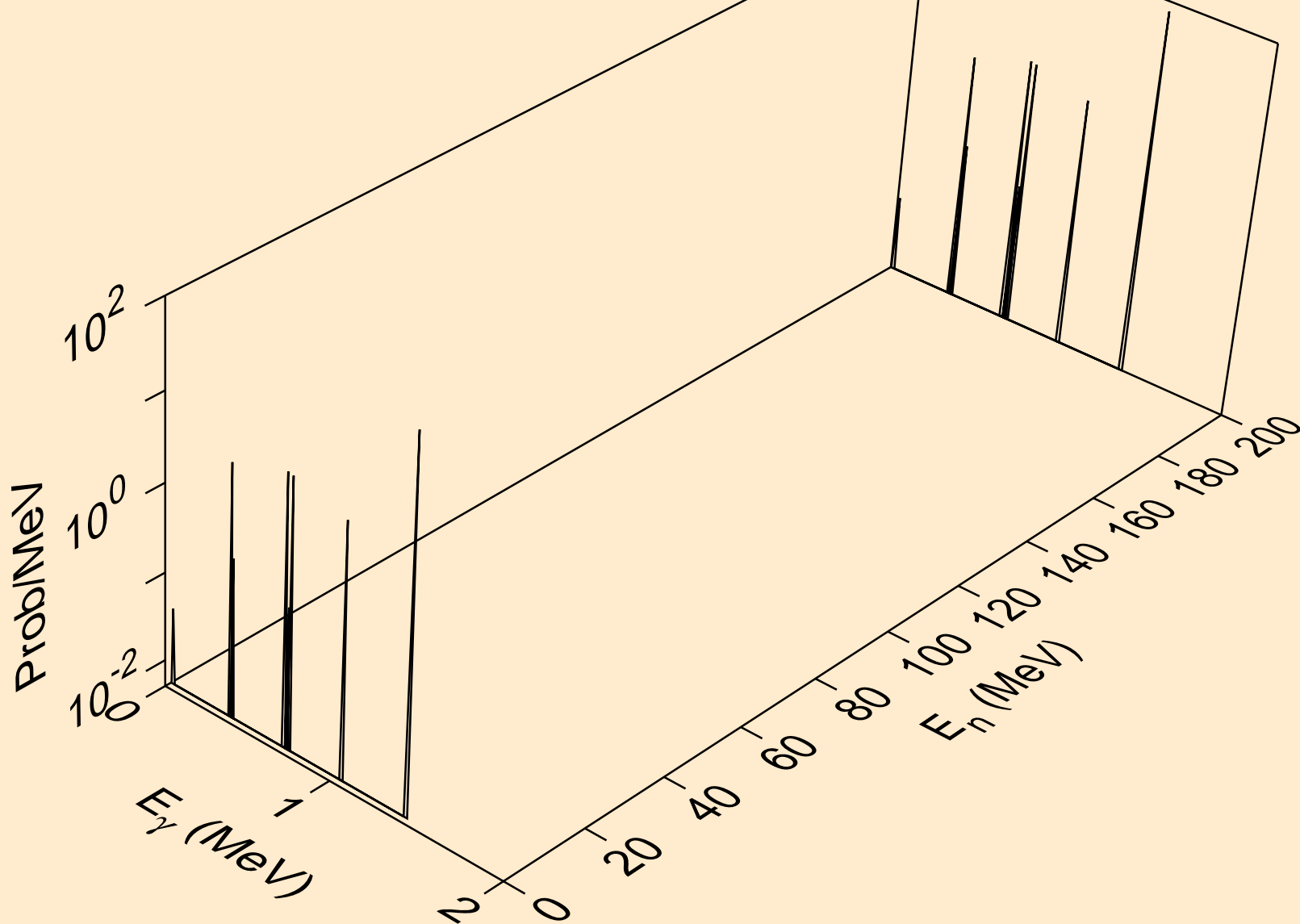

21-SC-45 FOR FENDL-3.1 FROM JEFF-3.1.1 WITH NJOY2012.50+  
Photon emission for (n,n\*11)

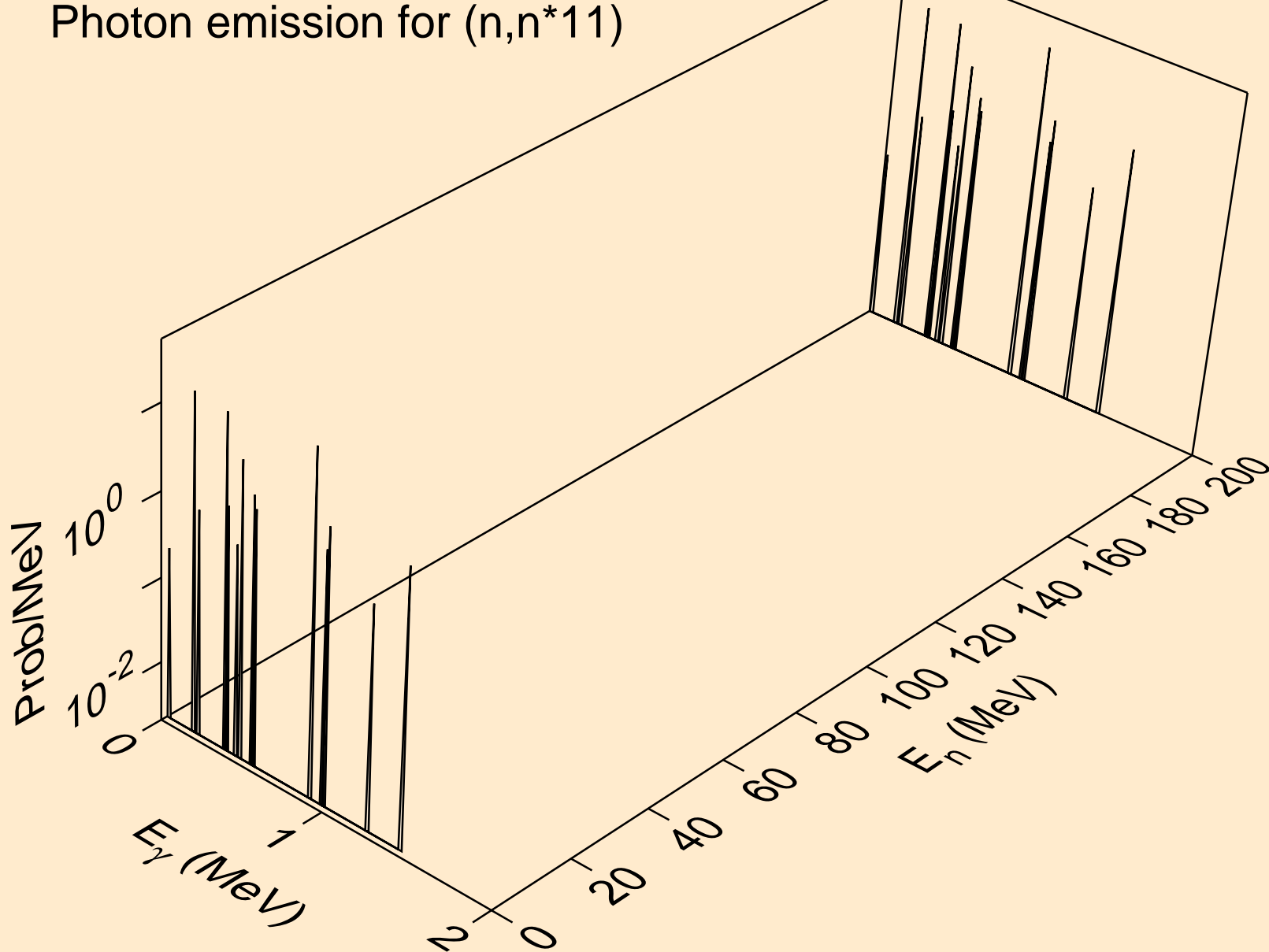

21-SC-45 FOR FENDL-3.1 FROM JEFF-3.1.1 WITH NJOY2012.50+  
Photon emission for (n,n\*12)

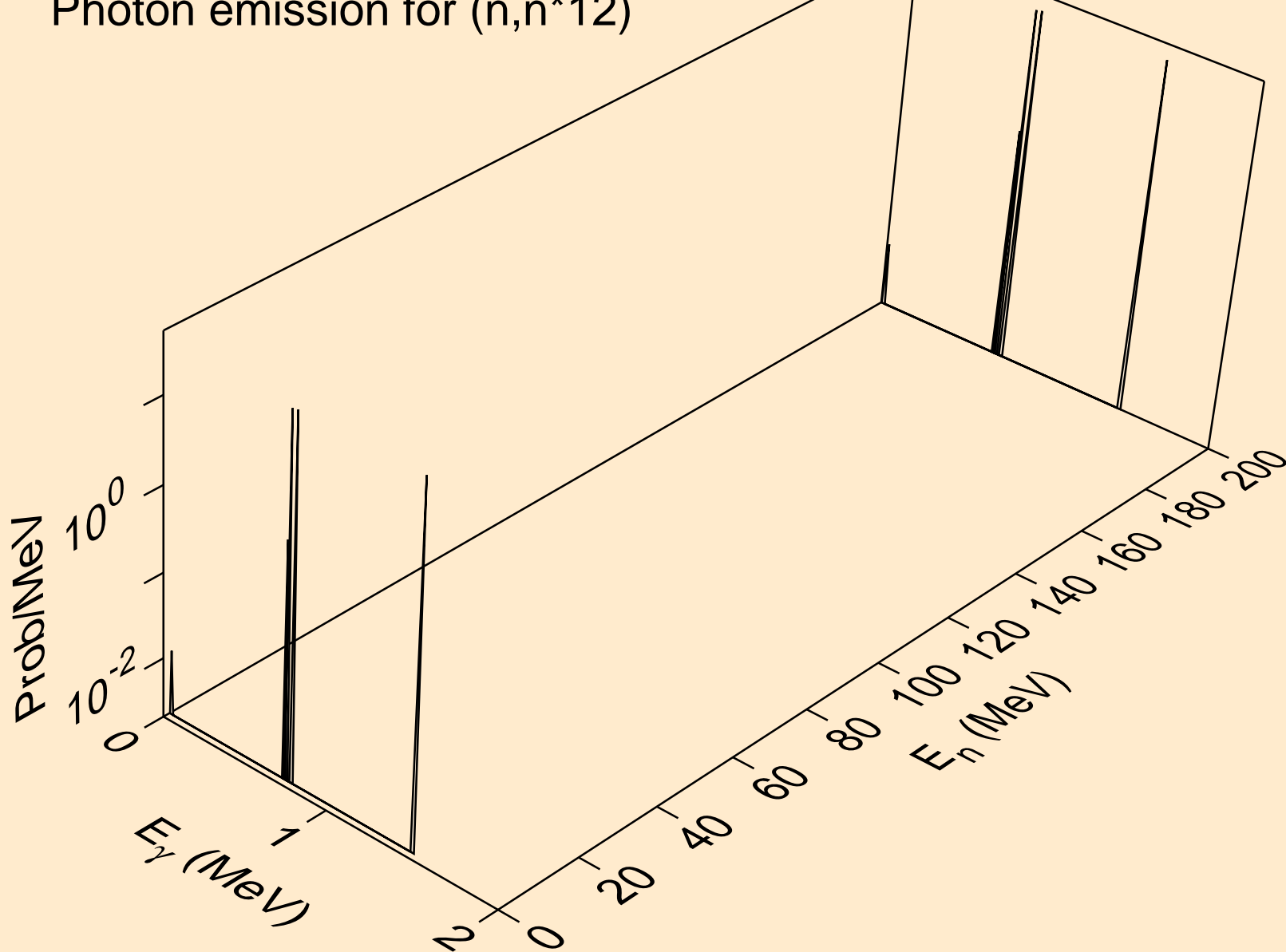

21-SC-45 FOR FENDL-3.1 FROM JEFF-3.1.1 WITH NJOY2012.50+  
Photon emission for (n,n\*13)

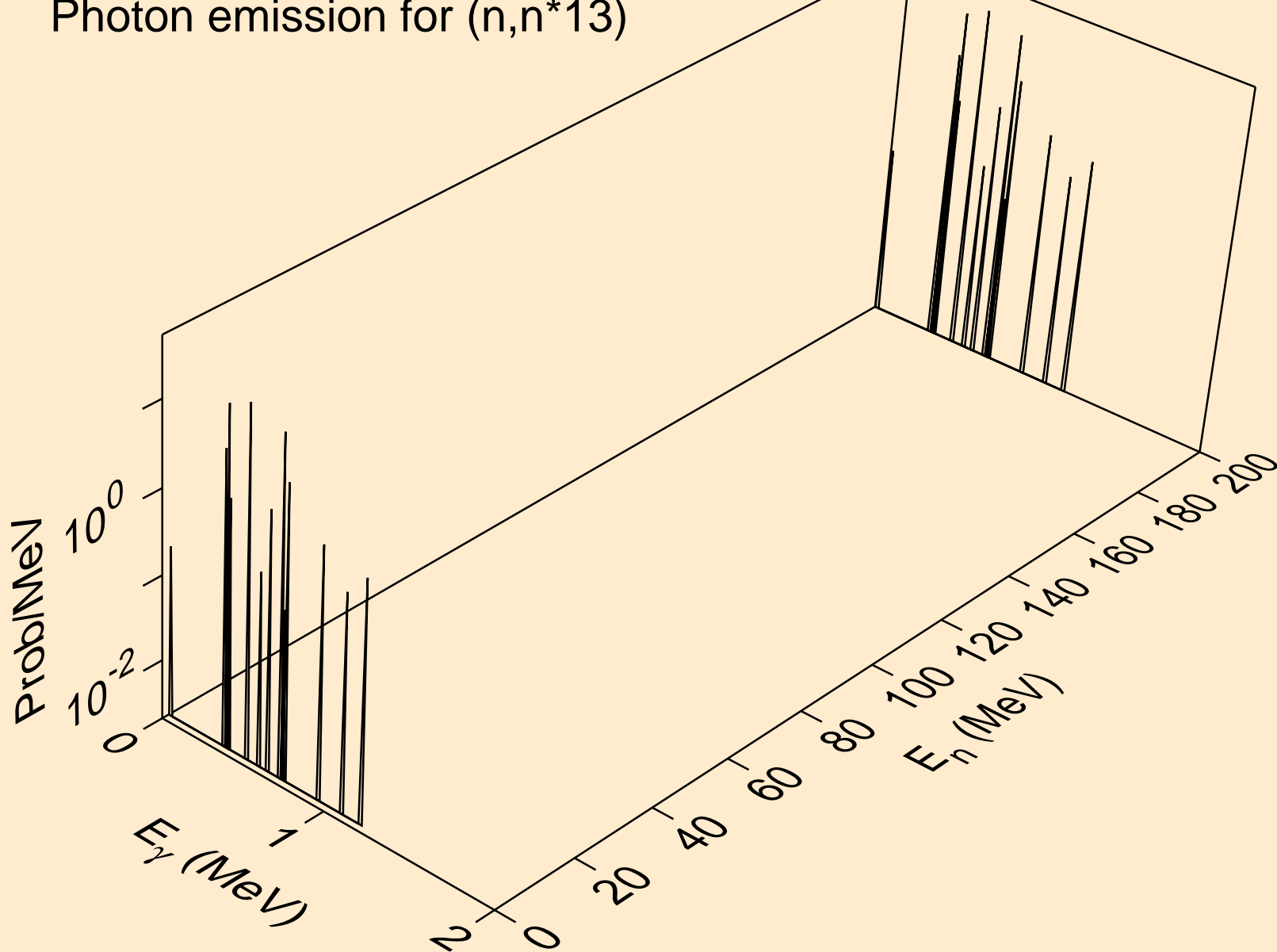

21-SC-45 FOR FENDL-3.1 FROM JEFF-3.1.1 WITH NJOY2012.50+  
Photon emission for (n,n\*14)

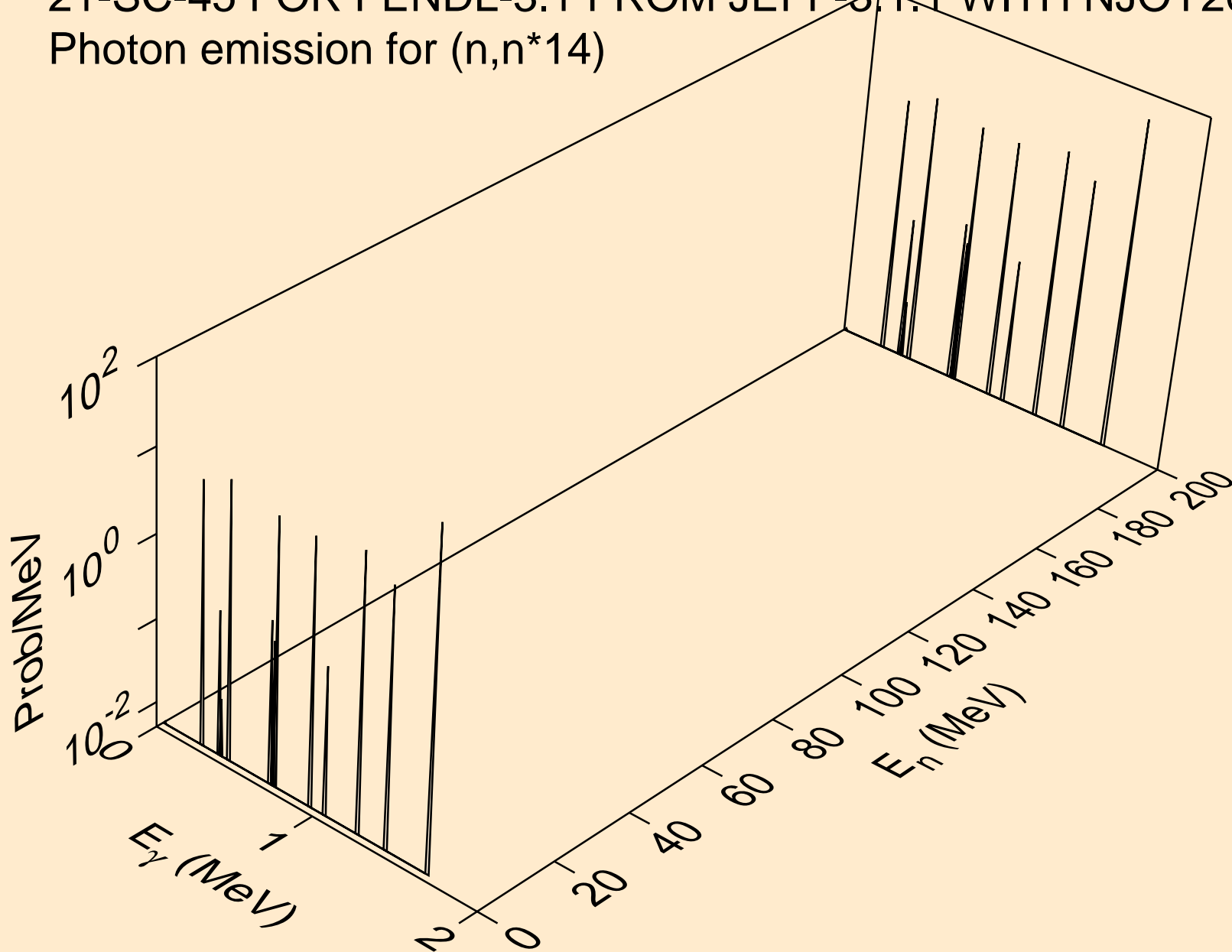

21-SC-45 FOR FENDL-3.1 FROM JEFF-3.1.1 WITH NJOY2012.50+  
Photon emission for (n,n\*15)

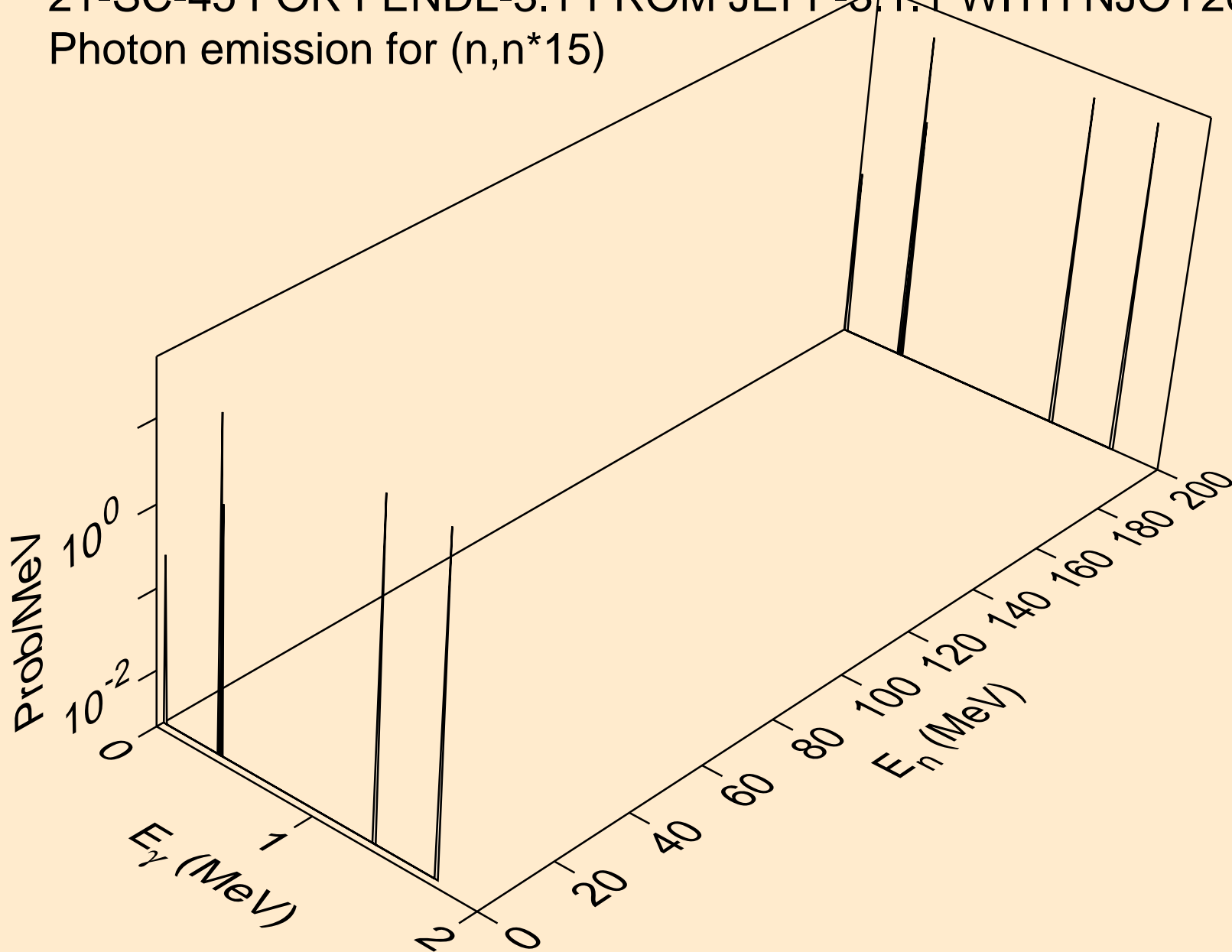



21-SC-45 FOR FENDL-3.1 FROM JEFF-3.1.1 WITH NJOY2012.50+  
Photon emission for (n,n\*16)

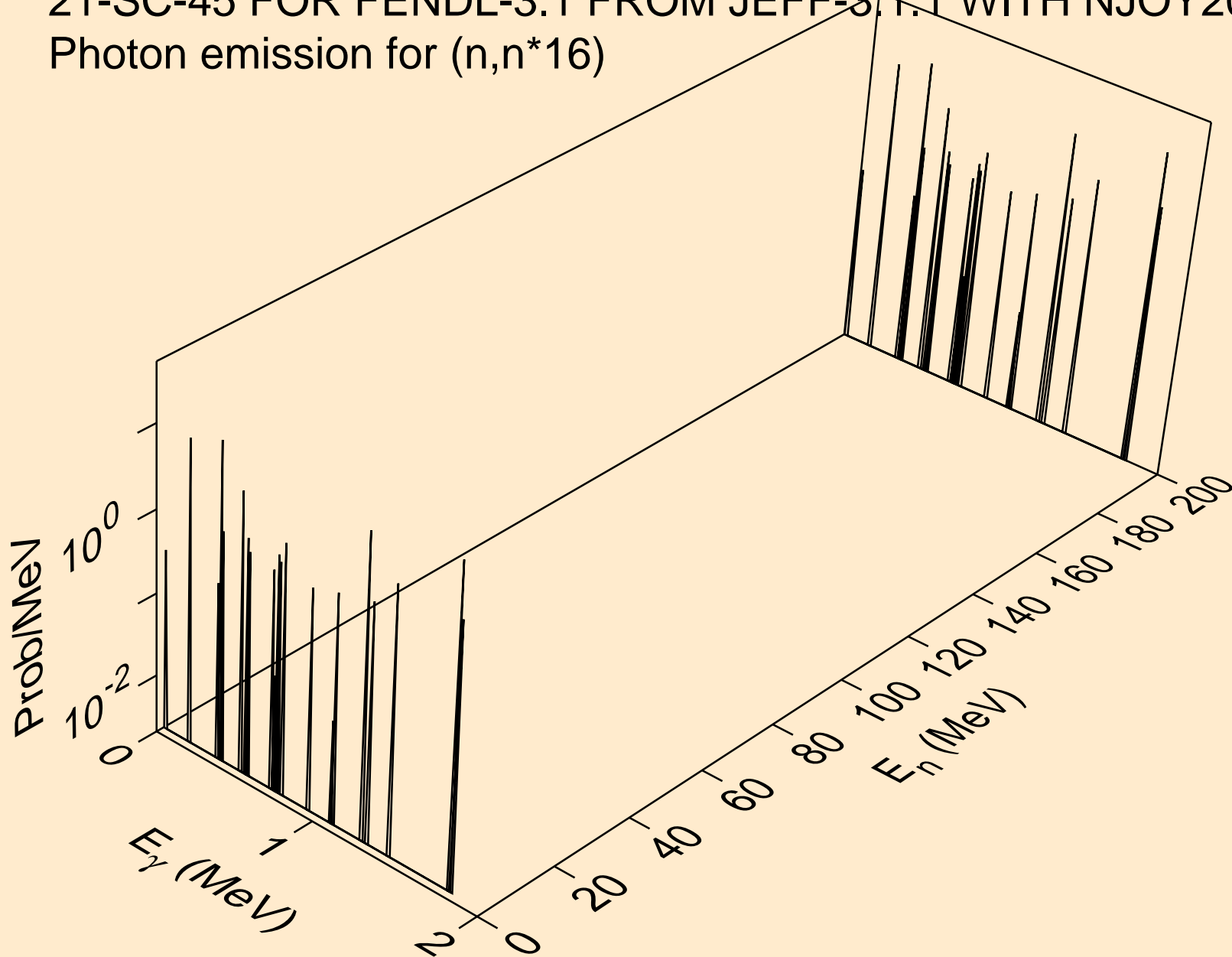

21-SC-45 FOR FENDL-3.1 FROM JEFF-3.1.1 WITH NJOY2012.50+  
Photon emission for (n,n\*17)

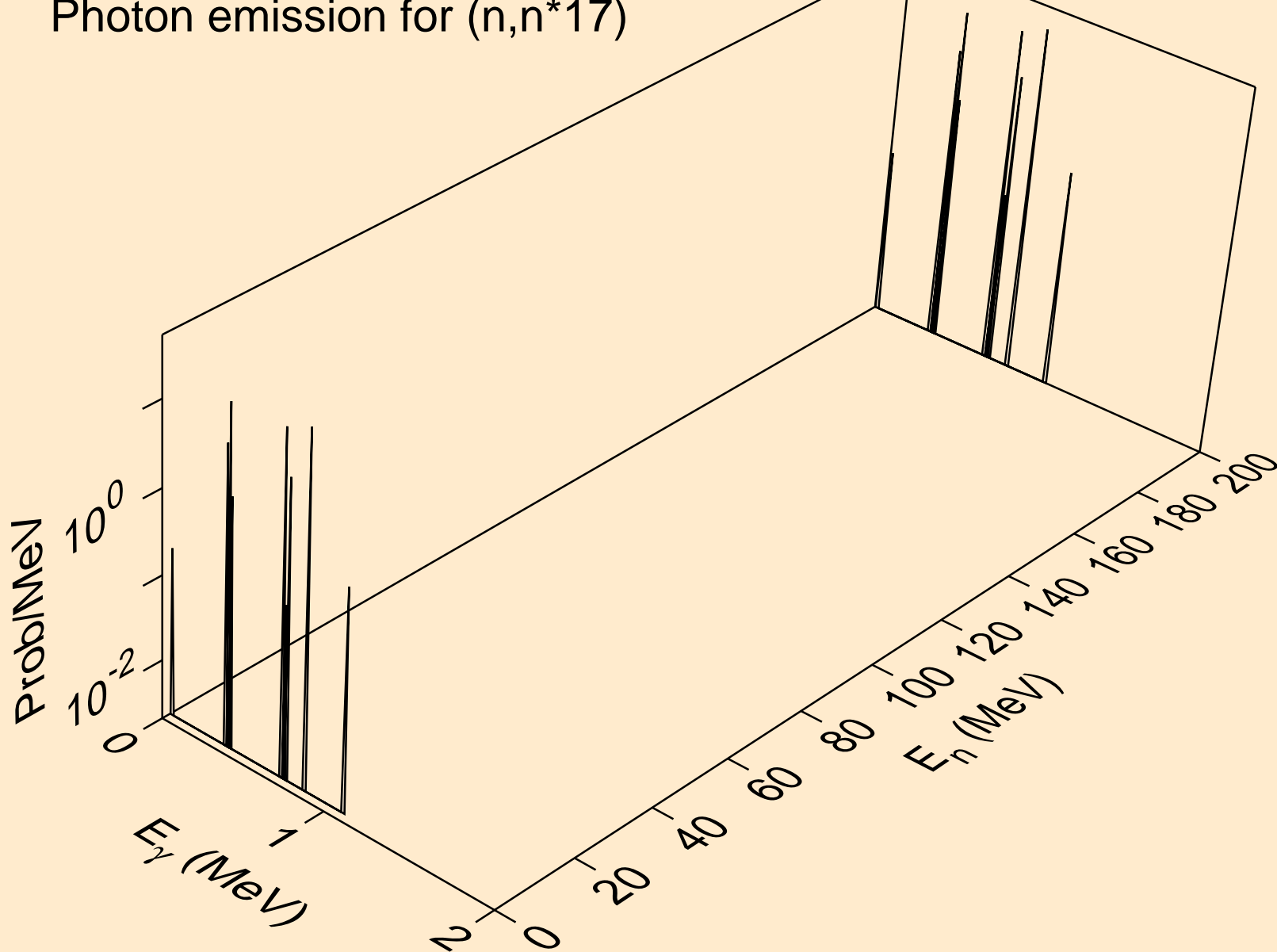

21-SC-45 FOR FENDL-3.1 FROM JEFF-3.1.1 WITH NJOY2012.50+  
Photon emission for (n,n\*18)

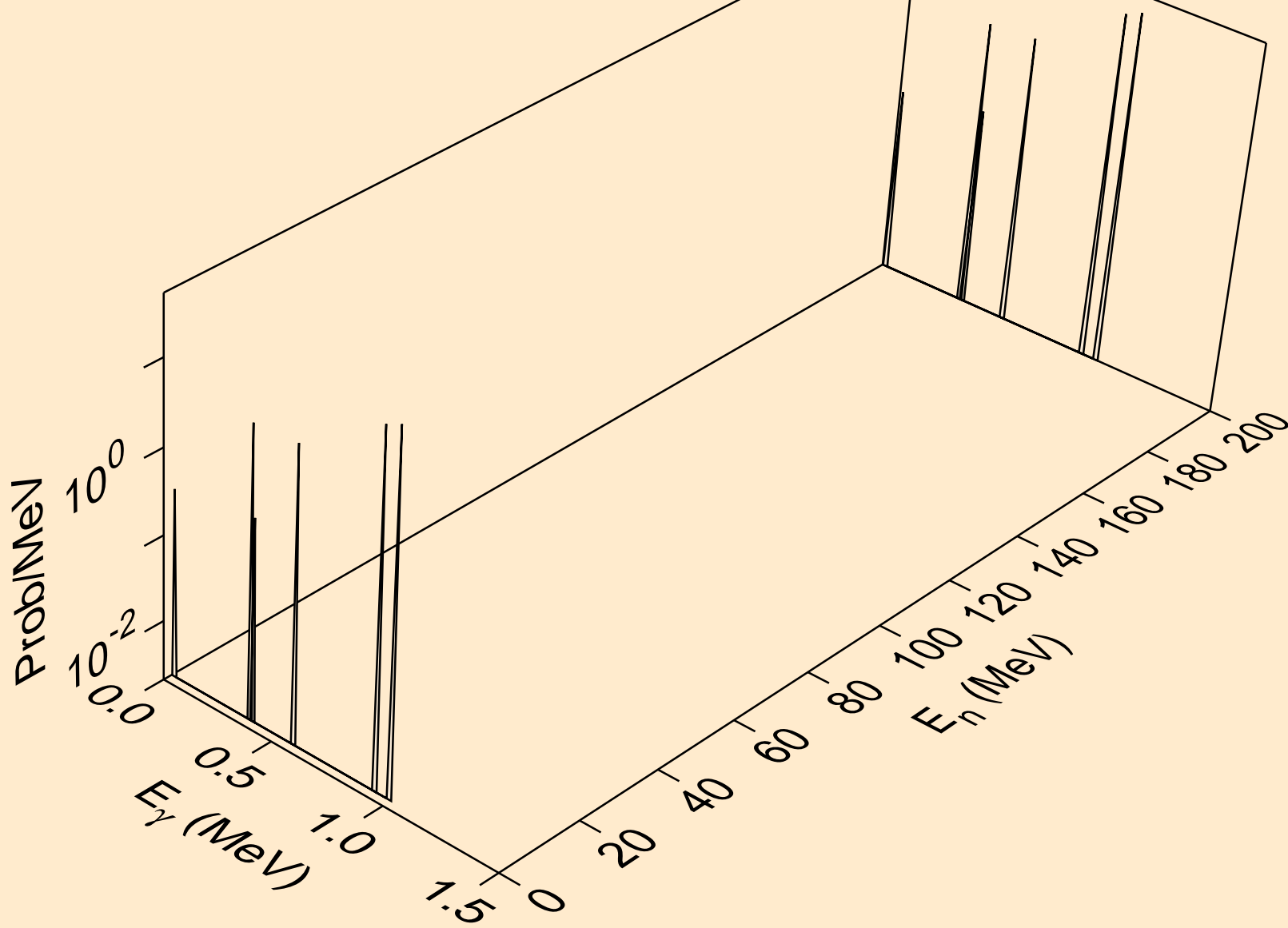

21-SC-45 FOR FENDL-3.1 FROM JEFF-3.1.1 WITH NJOY2012.50+  
Photon emission for (n,n\*19)

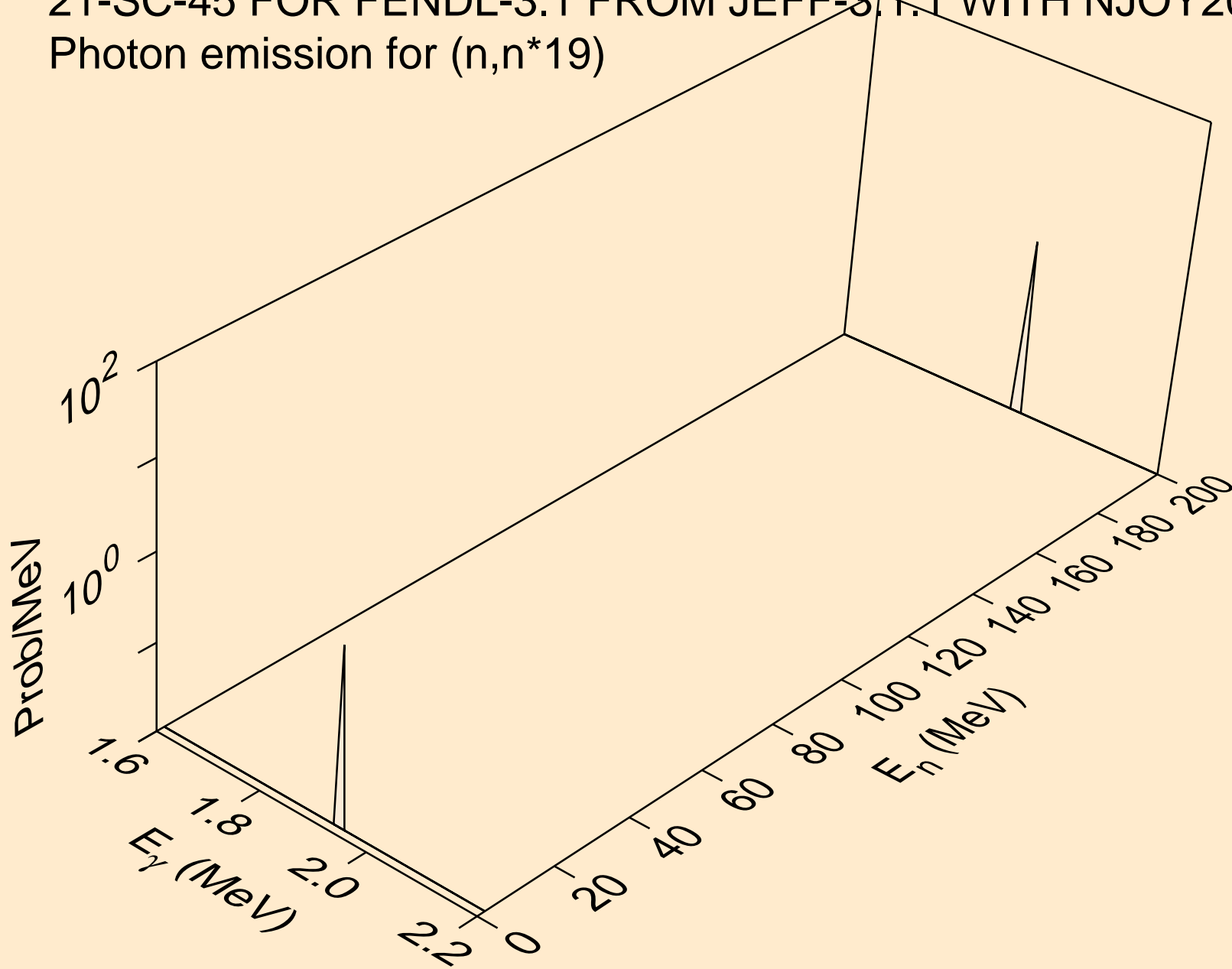

21-SC-45 FOR FENDL-3.1 FROM JEFF-3.1.1 WITH NJOY2012.50+  
Photon emission for (n,n\*20)

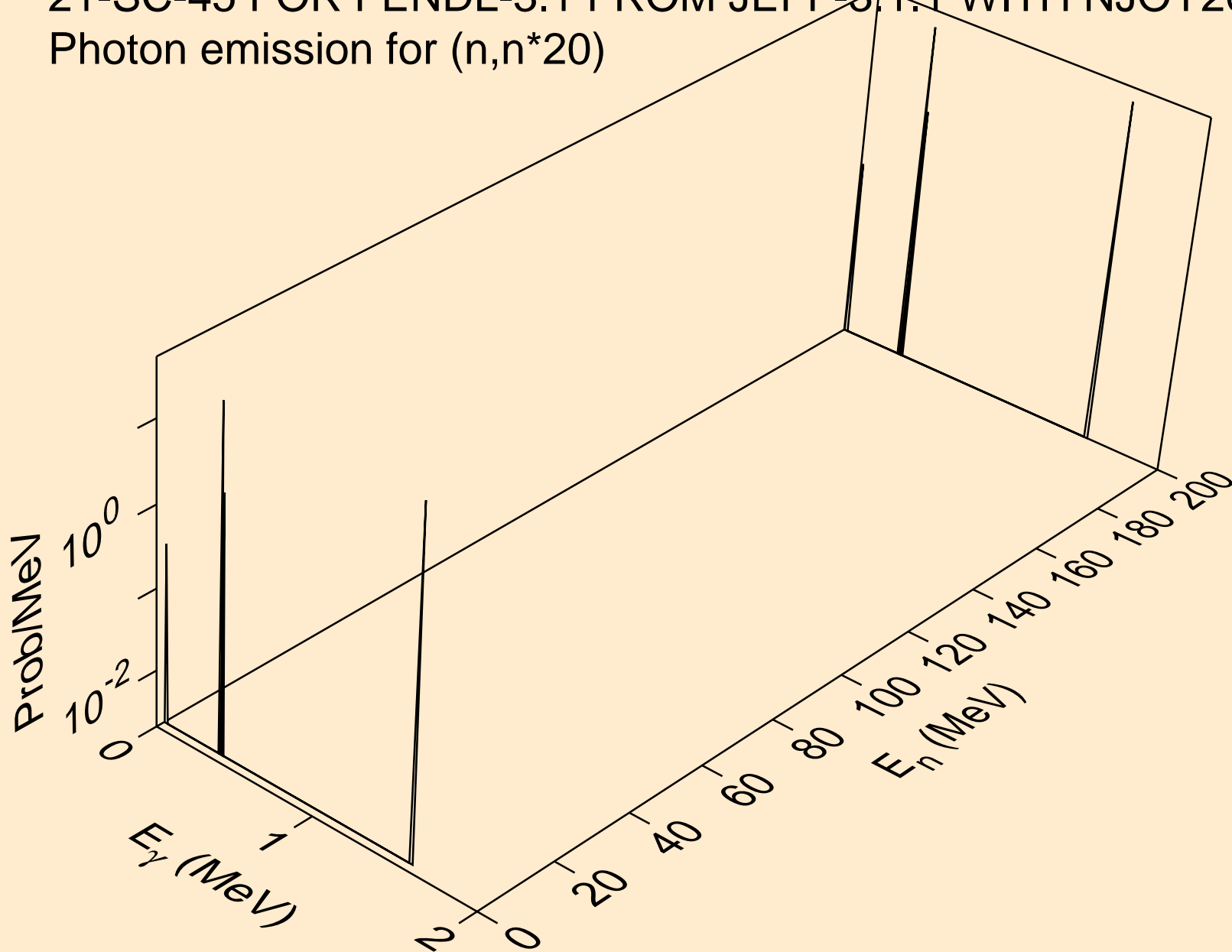

21-SC-45 FOR FENDL-3.1 FROM JEFF-3.1.1 WITH NJOY2012.50+  
Photon emission for (n,n\*c)

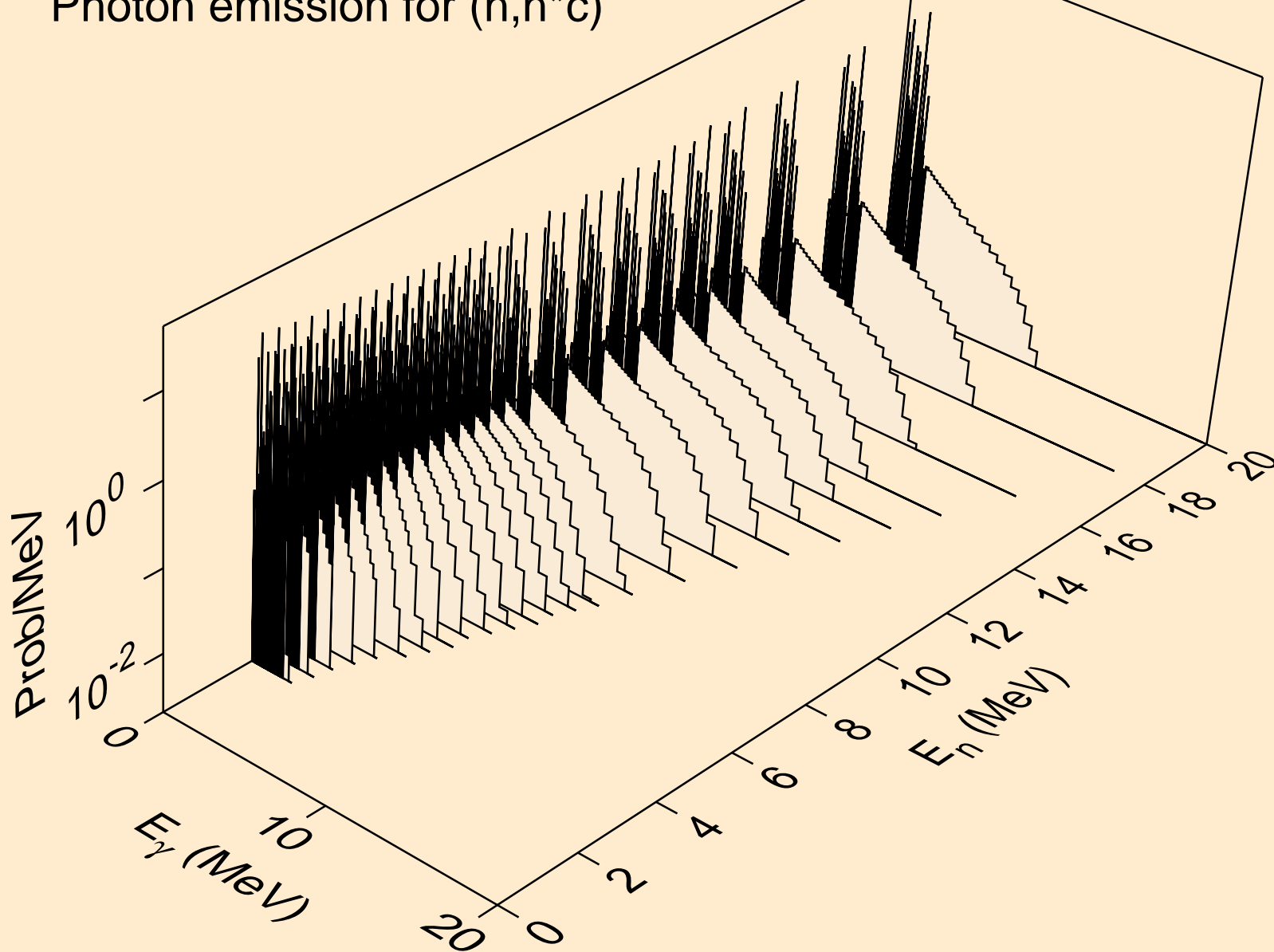

21-SC-45 FOR FENDL-3.1 FROM JEFF-3.1.1 WITH NJOY2012.50+  
Photon emission for (n,gma)

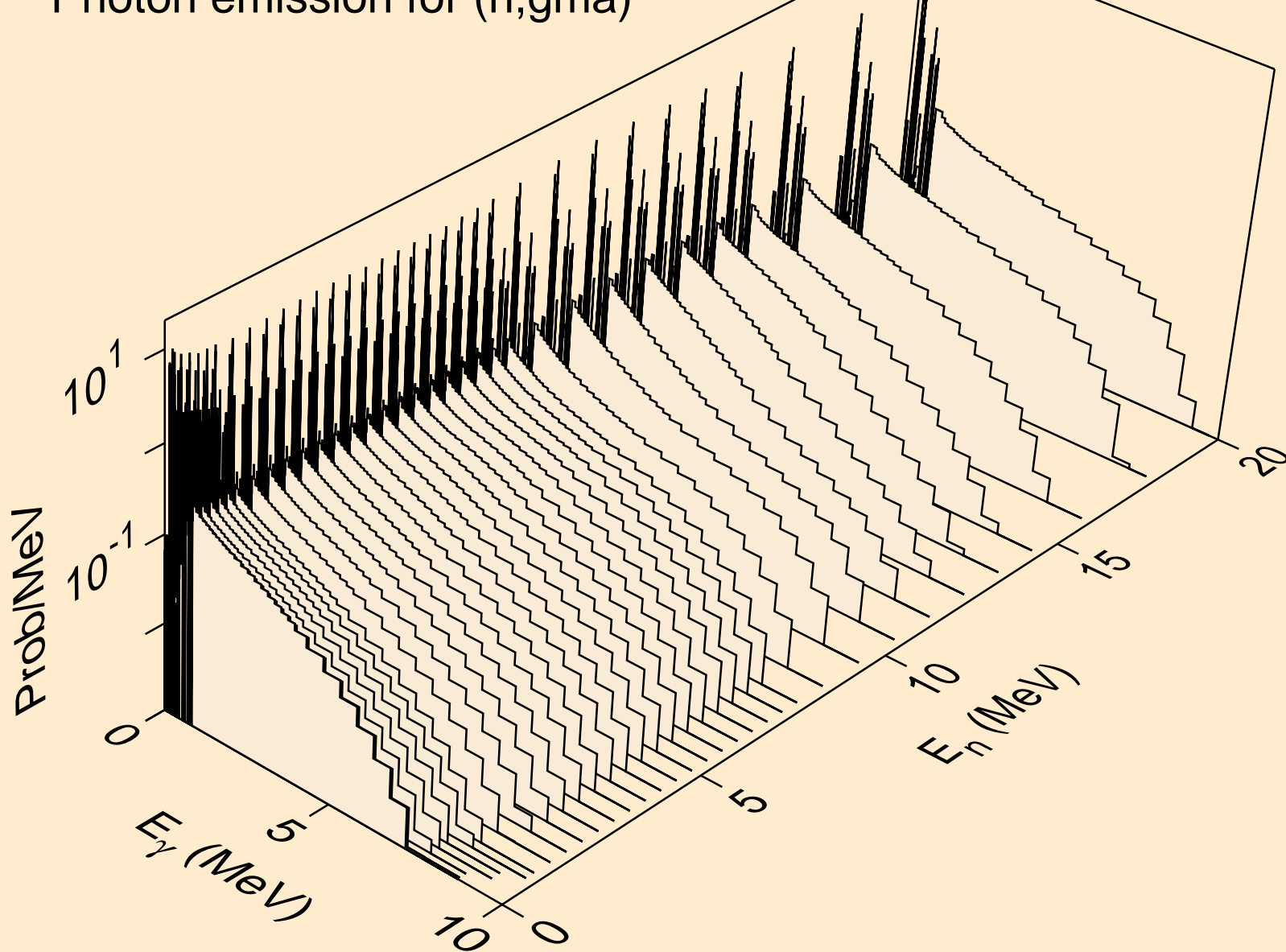

21-SC-45 FOR FENDL-3.1 FROM JEFF-3.1.1 WITH NJOY2012.50+  
Photon emission for (n,2a)

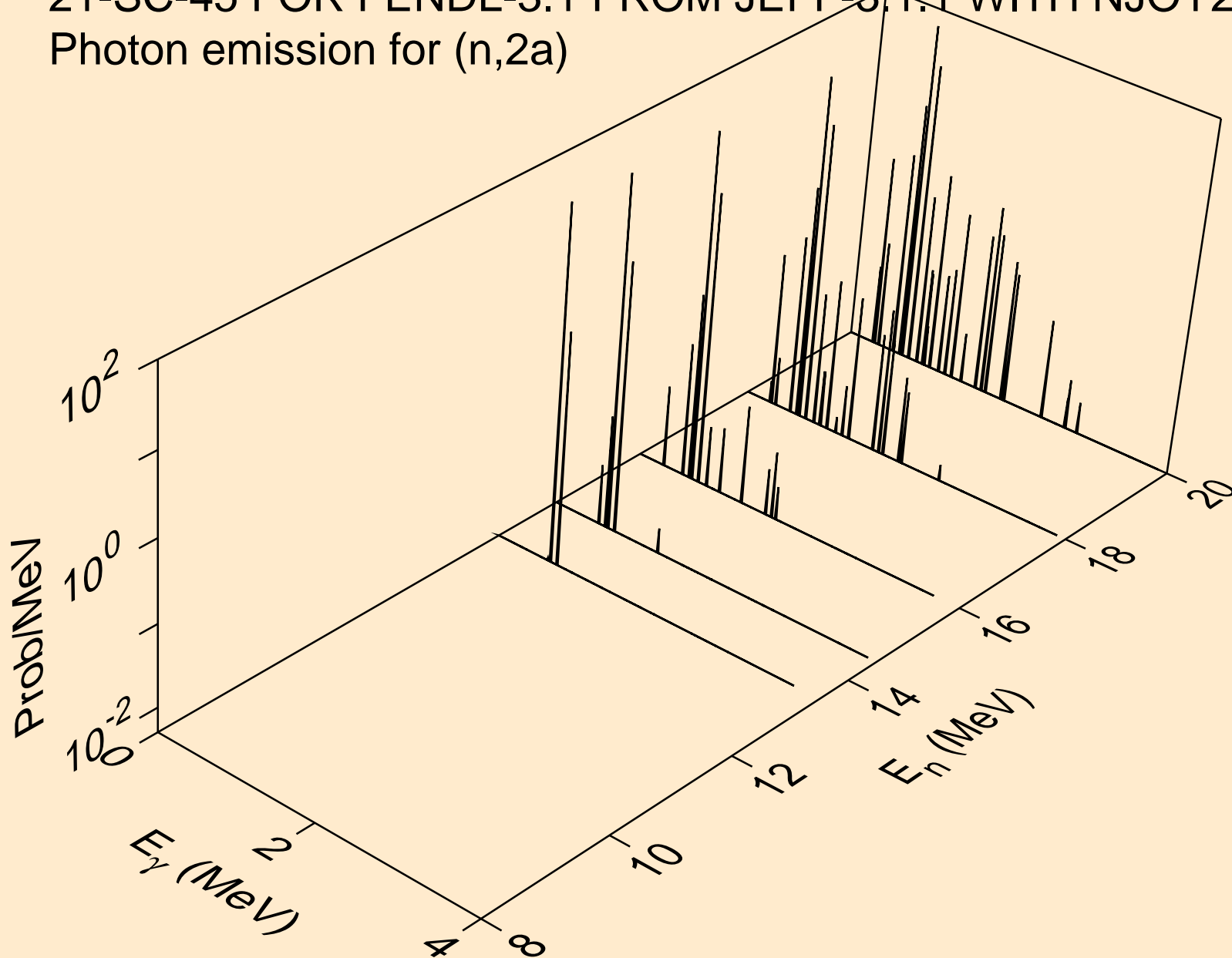



21-SC-45 FOR FENDL-3.1 FROM JEFF-3.1.1 WITH NJOY2012.50+  
Photon emission for (n,2p)

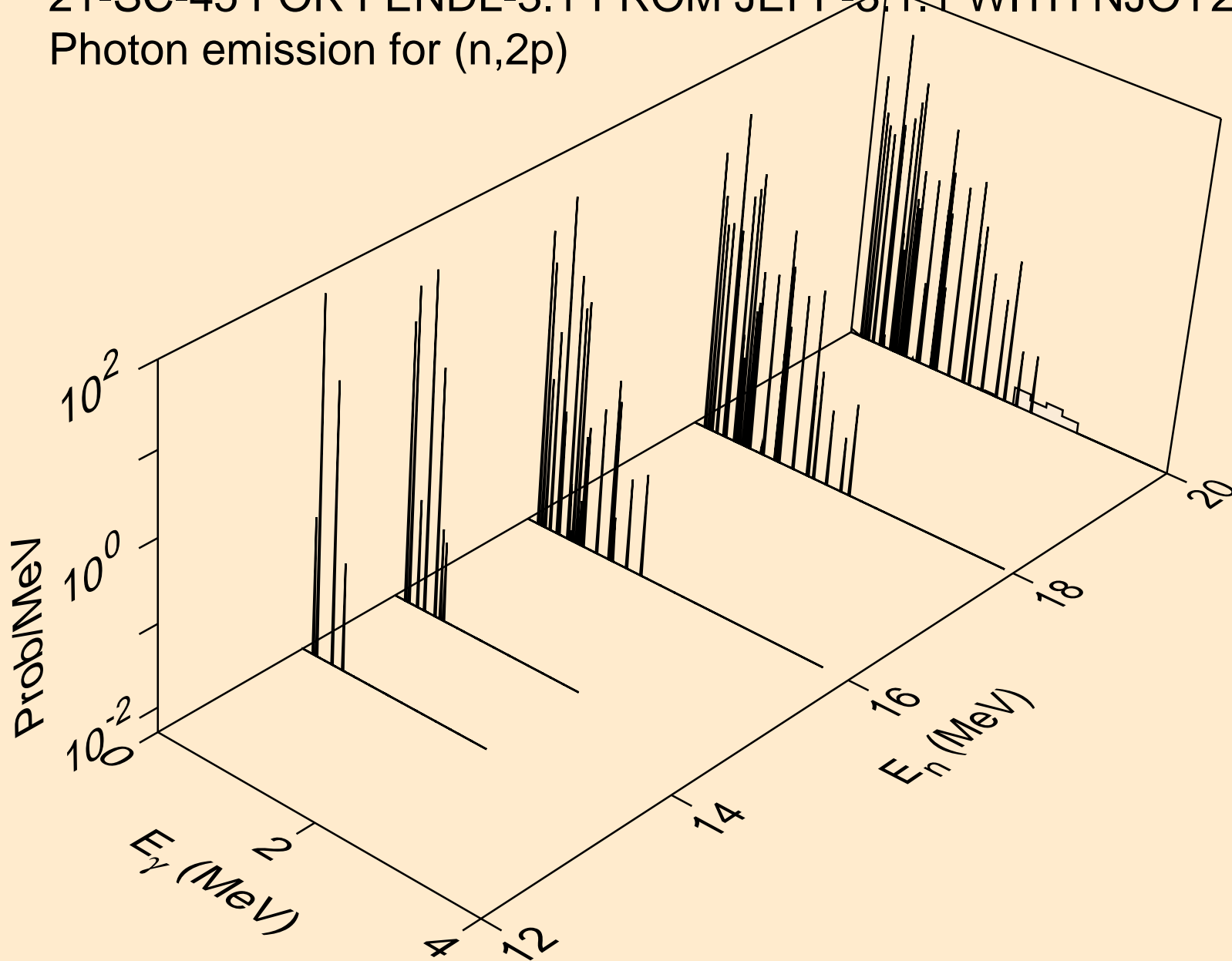

21-SC-45 FOR FENDL-3.1 FROM JEFF-3.1.1 WITH NJOY2012.50+  
Photon emission for (n,pa)

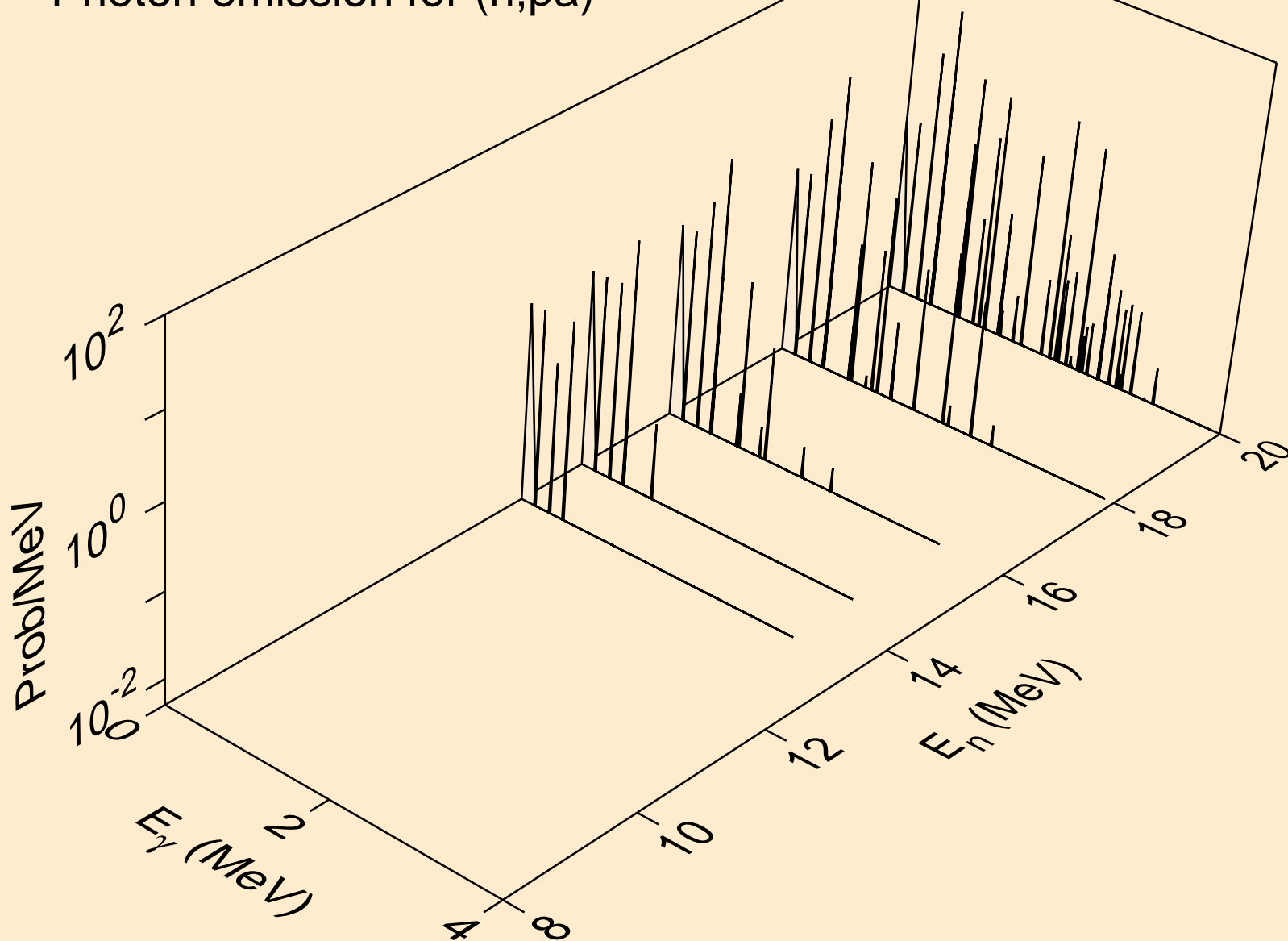

21-SC-45 FOR FENDL-3.1 FROM JEFF-3.1.1 WITH NJOY2012.50+  
Photon emission for (n,da)

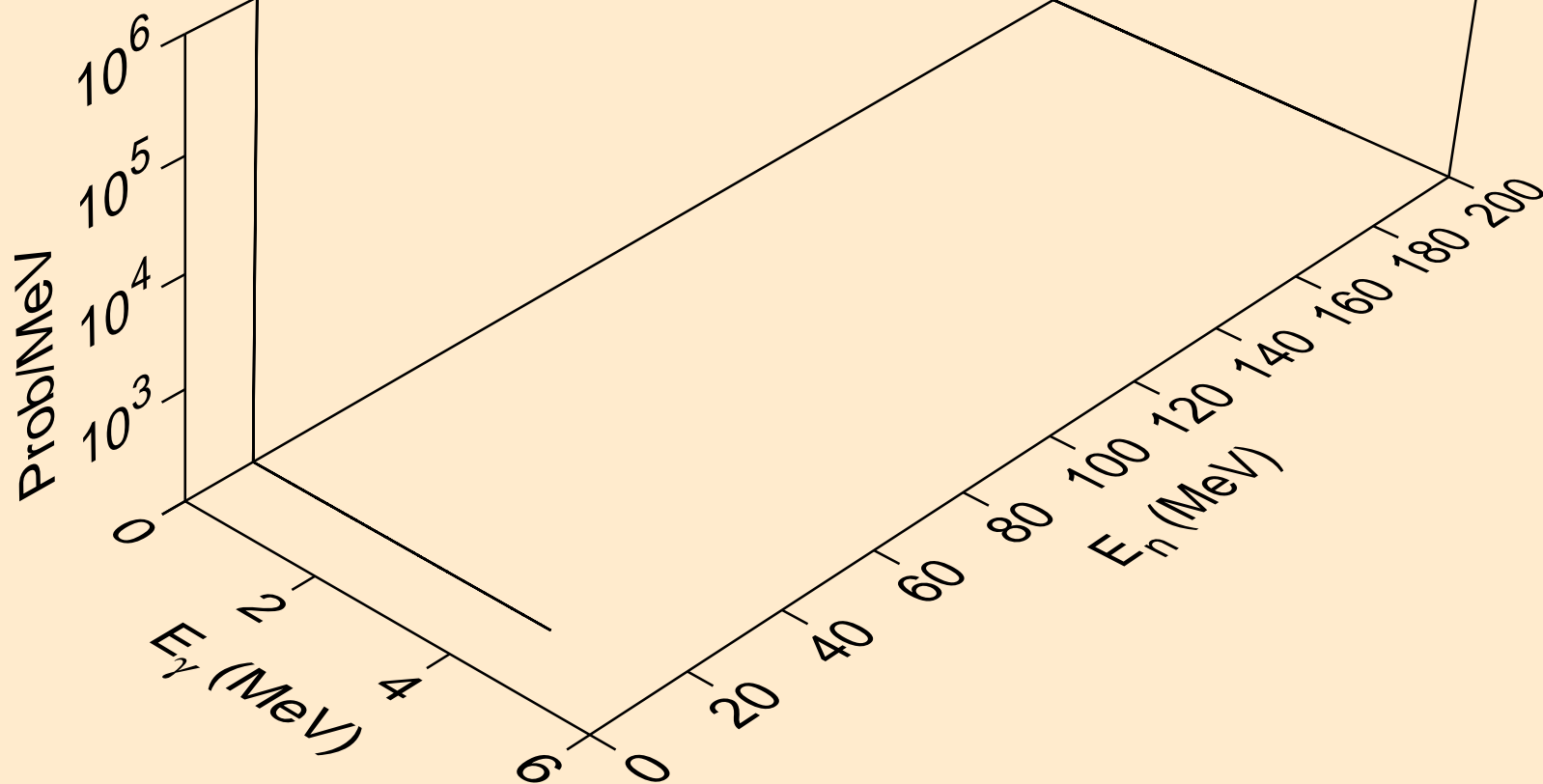

21-SC-45 FOR FENDL-3.1 FROM JEFF-3.1.1 WITH NJOY2012.50+  
Photon emission for (n,p\*1)

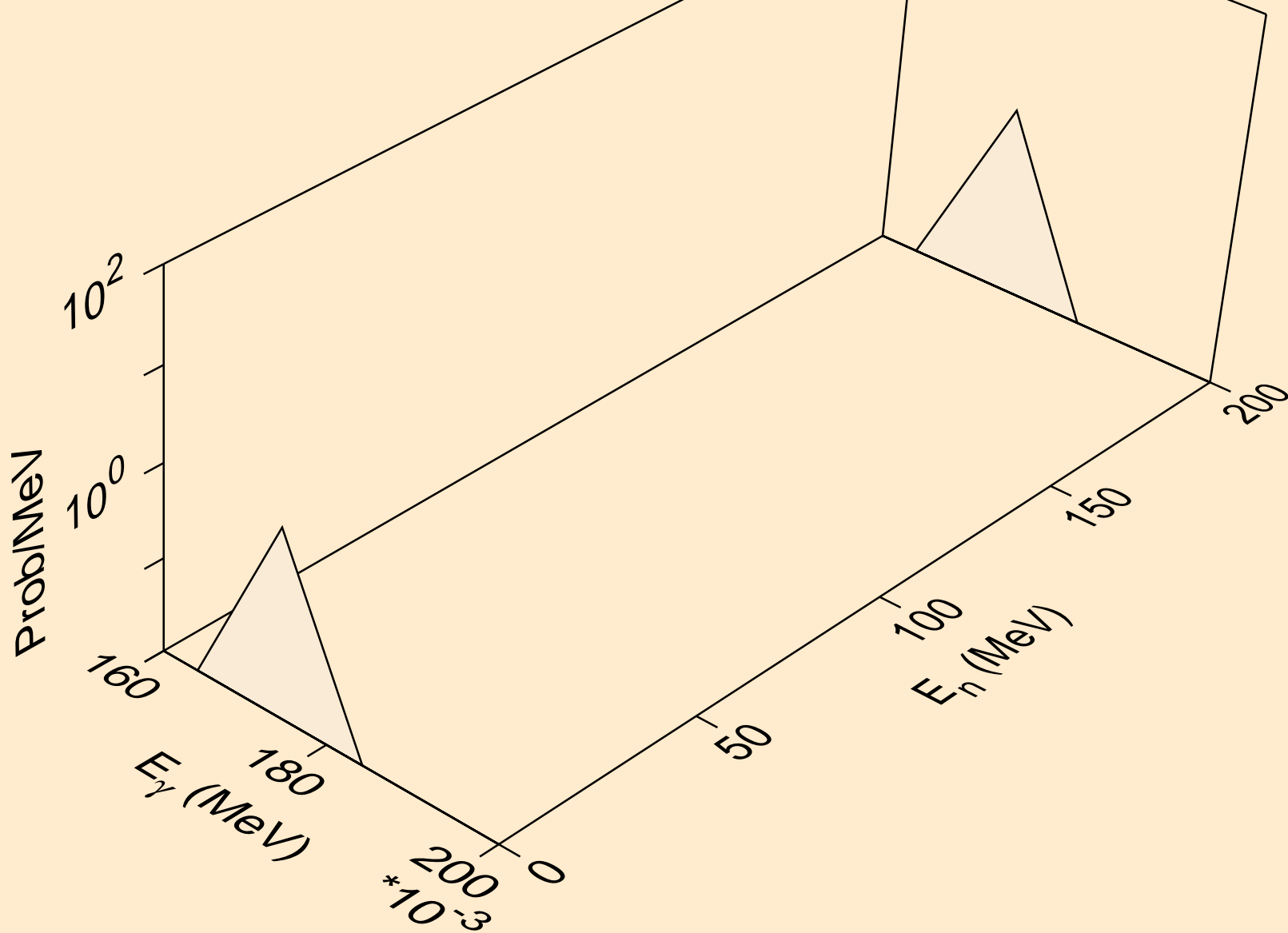

21-SC-45 FOR FENDL-3.1 FROM JEFF-3.1.1 WITH NJOY2012.50+  
Photon emission for (n,p\*2)

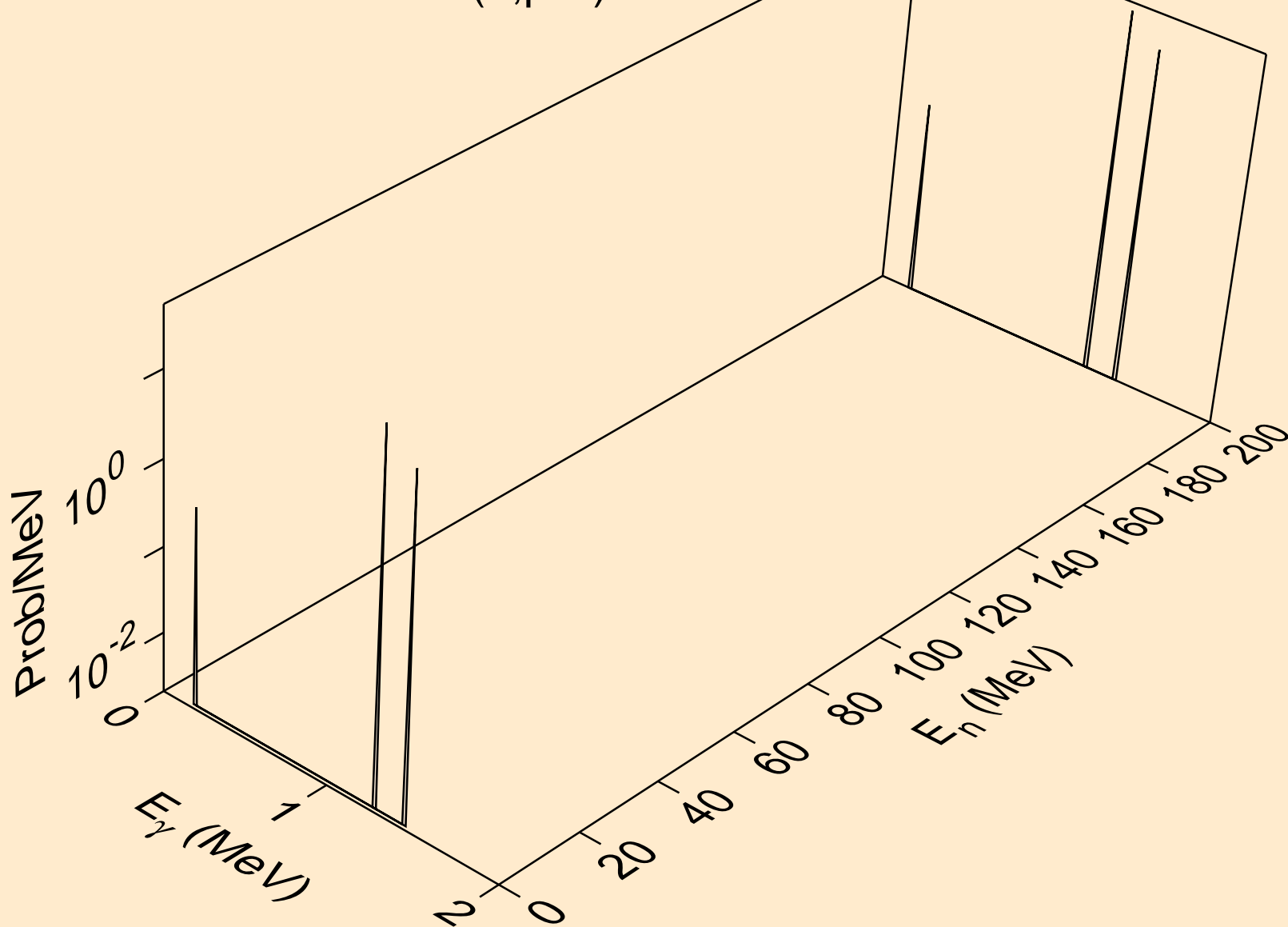

21-SC-45 FOR FENDL-3.1 FROM JEFF-3.1.1 WITH NJOY2012.50+  
Photon emission for (n,p\*3)

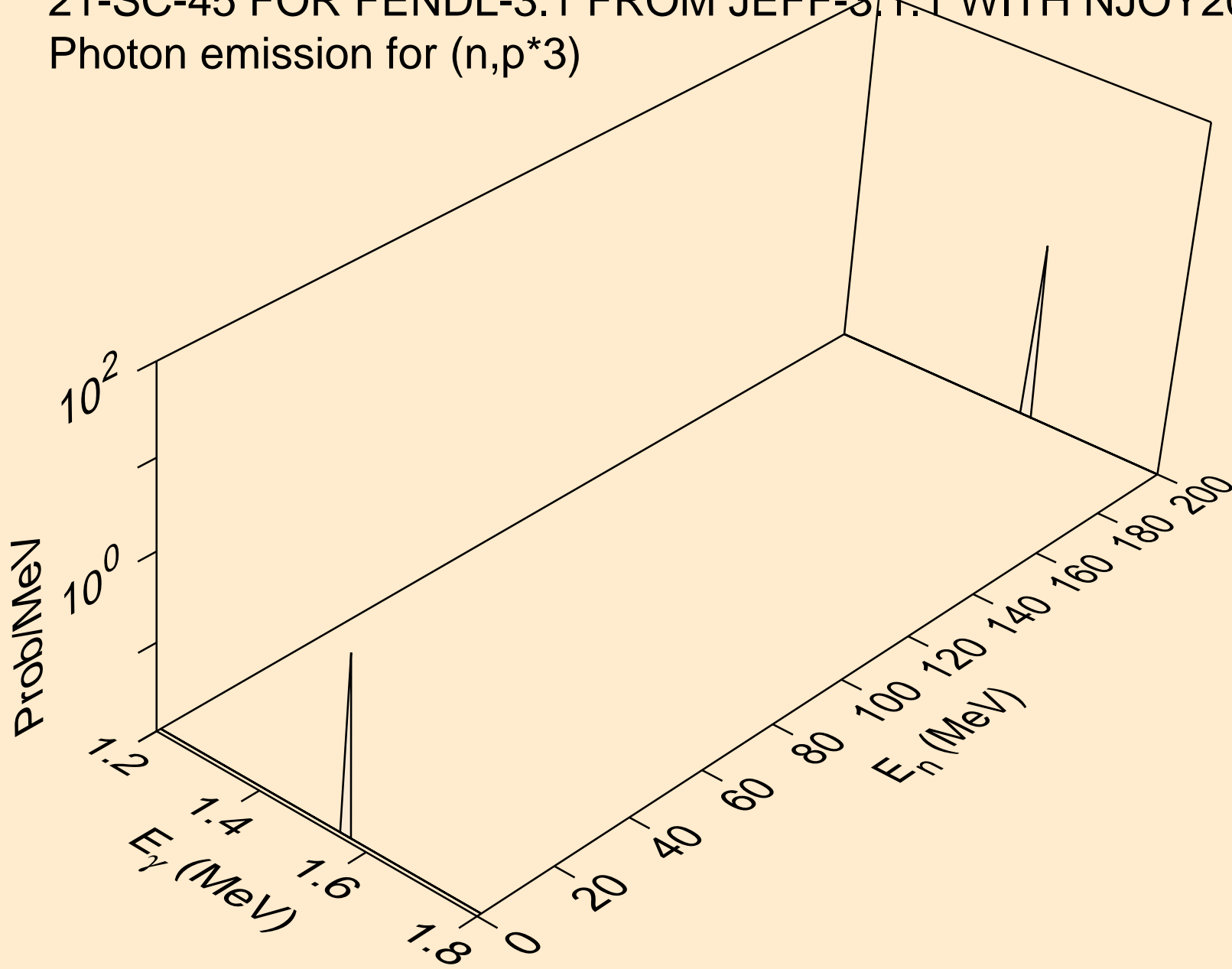

21-SC-45 FOR FENDL-3.1 FROM JEFF-3.1.1 WITH NJOY2012.50+  
Photon emission for (n,p\*4)

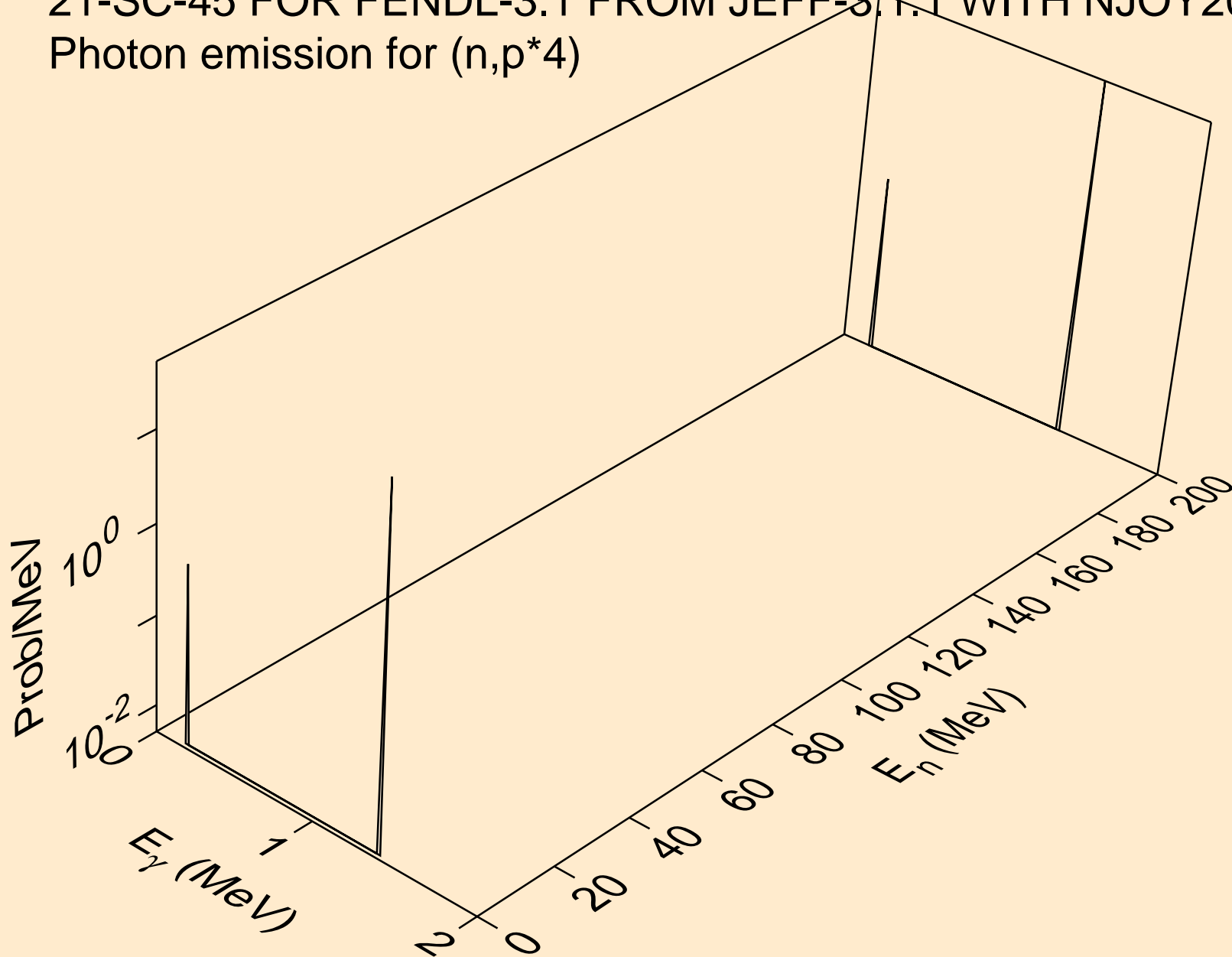

21-SC-45 FOR FENDL-3.1 FROM JEFF-3.1.1 WITH NJOY2012.50+  
Photon emission for (n,p\*5)

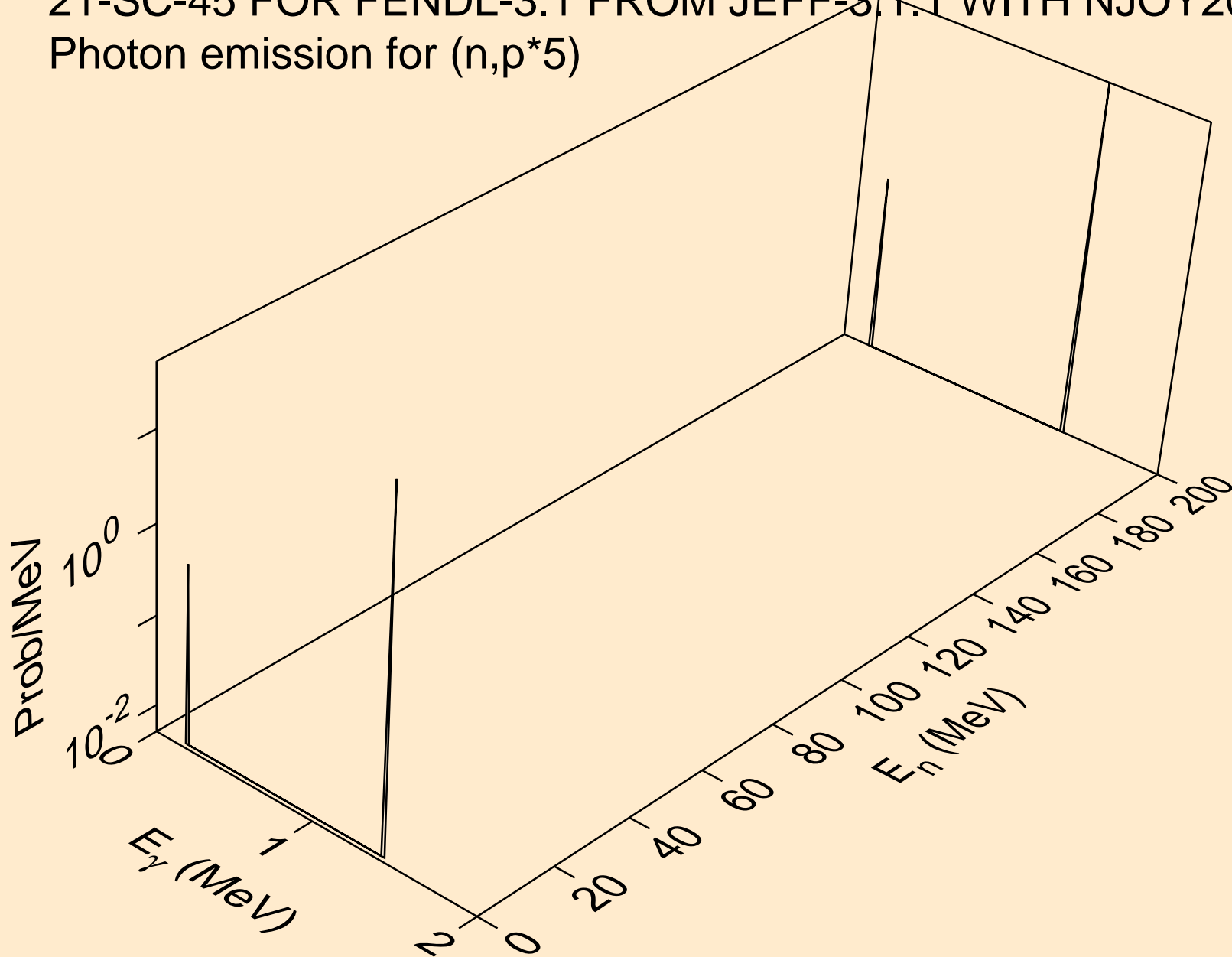



21-SC-45 FOR FENDL-3.1 FROM JEFF-3.1.1 WITH NJOY2012.50+  
Photon emission for (n,p\*6)

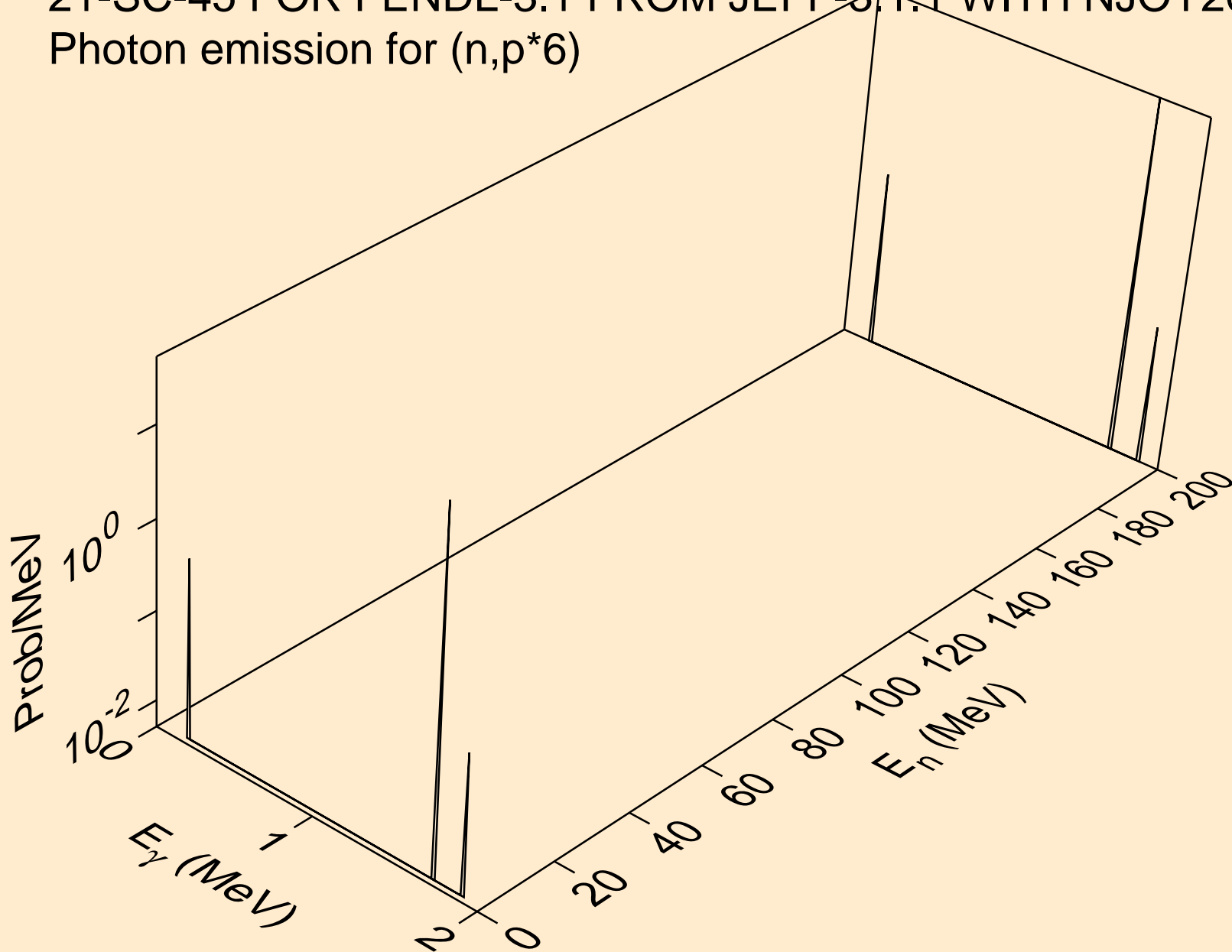

21-SC-45 FOR FENDL-3.1 FROM JEFF-3.1.1 WITH NJOY2012.50+  
Photon emission for (n,p\*7)

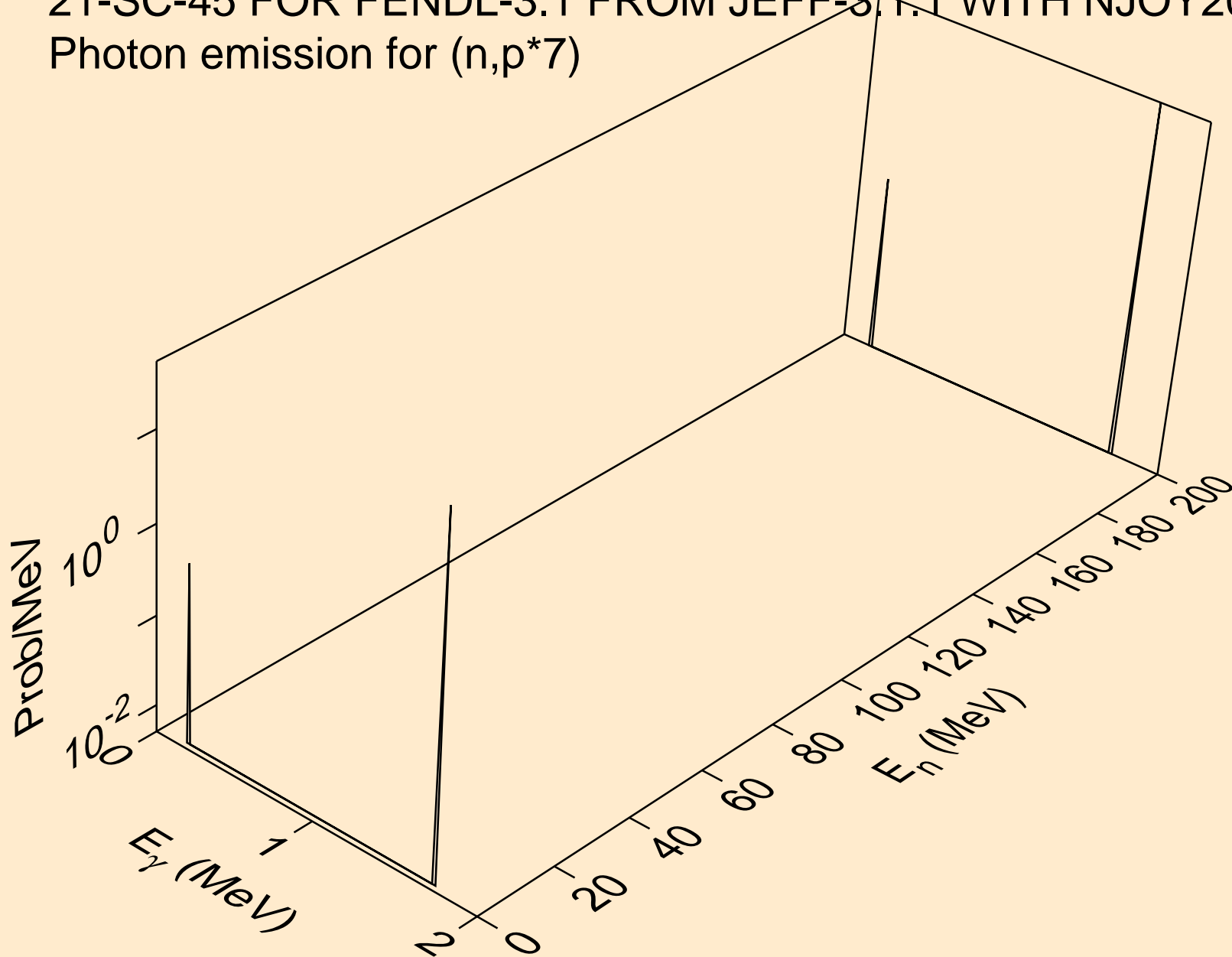

21-SC-45 FOR FENDL-3.1 FROM JEFF-3.1.1 WITH NJOY2012.50+  
Photon emission for (n,p\*8)

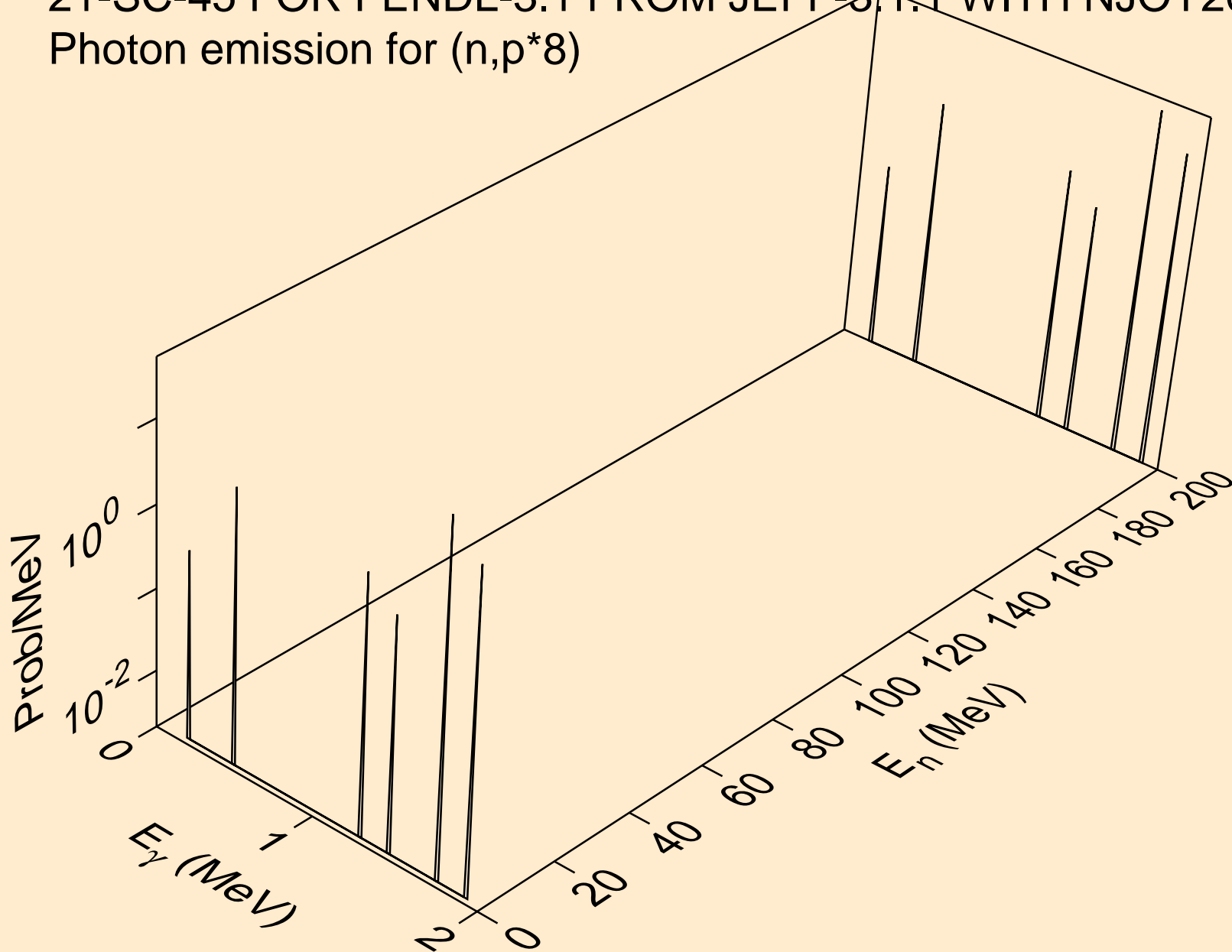

21-SC-45 FOR FENDL-3.1 FROM JEFF-3.1.1 WITH NJOY2012.50+  
Photon emission for (n,p\*9)

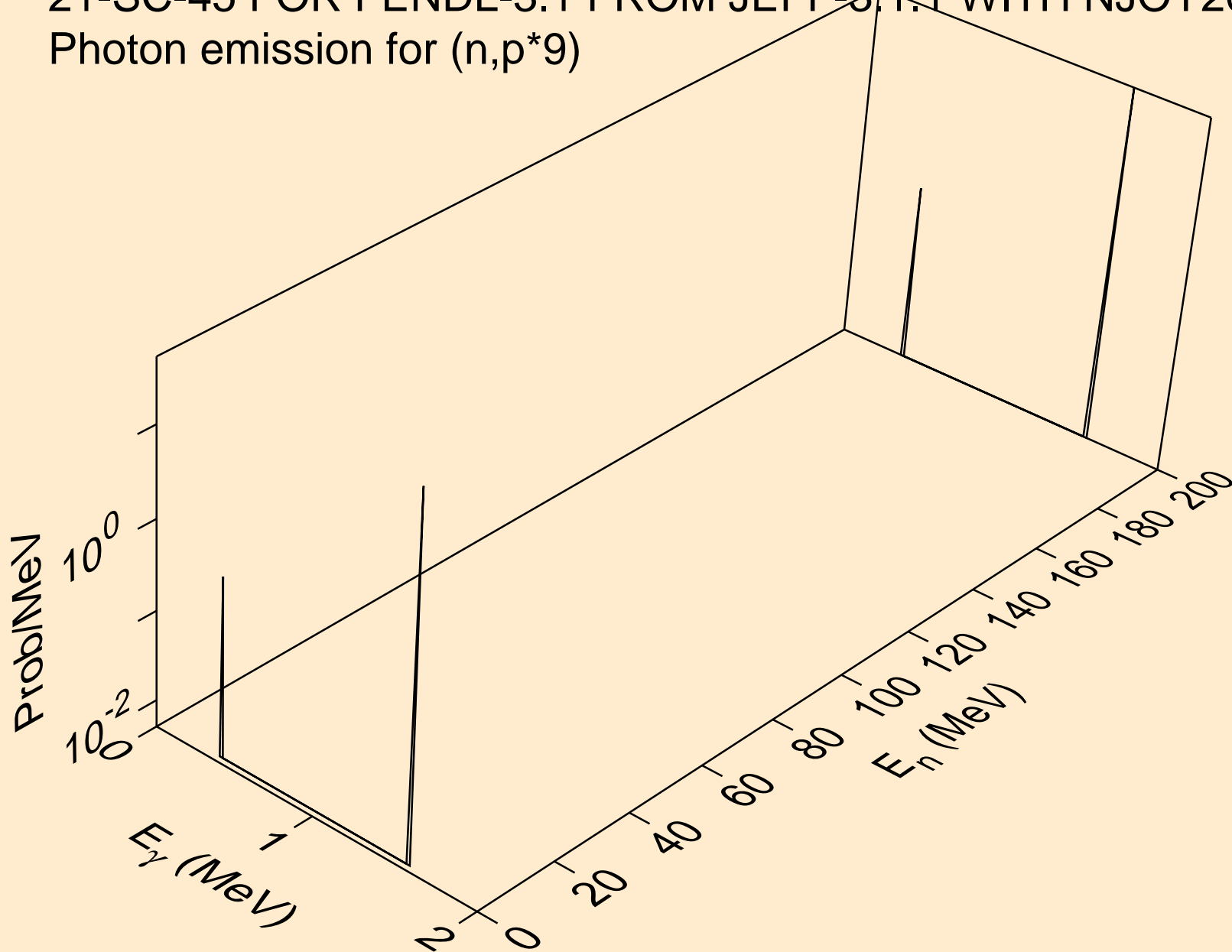

21-SC-45 FOR FENDL-3.1 FROM JEFF-3.1.1 WITH NJOY2012.50+  
Photon emission for (n,p\*10)

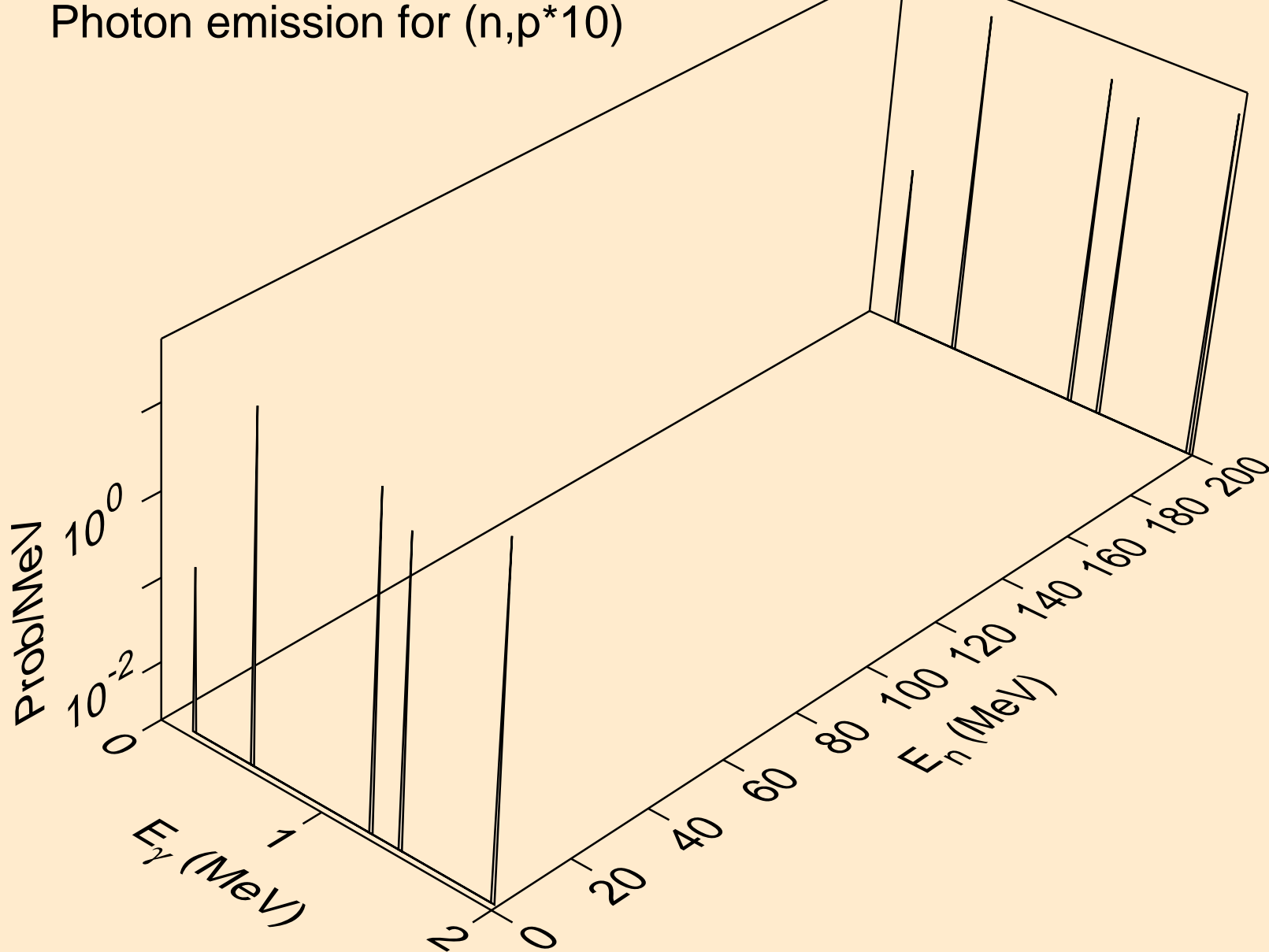

21-SC-45 FOR FENDL-3.1 FROM JEFF-3.1.1 WITH NJOY2012.50+  
Photon emission for (n,p\*c)

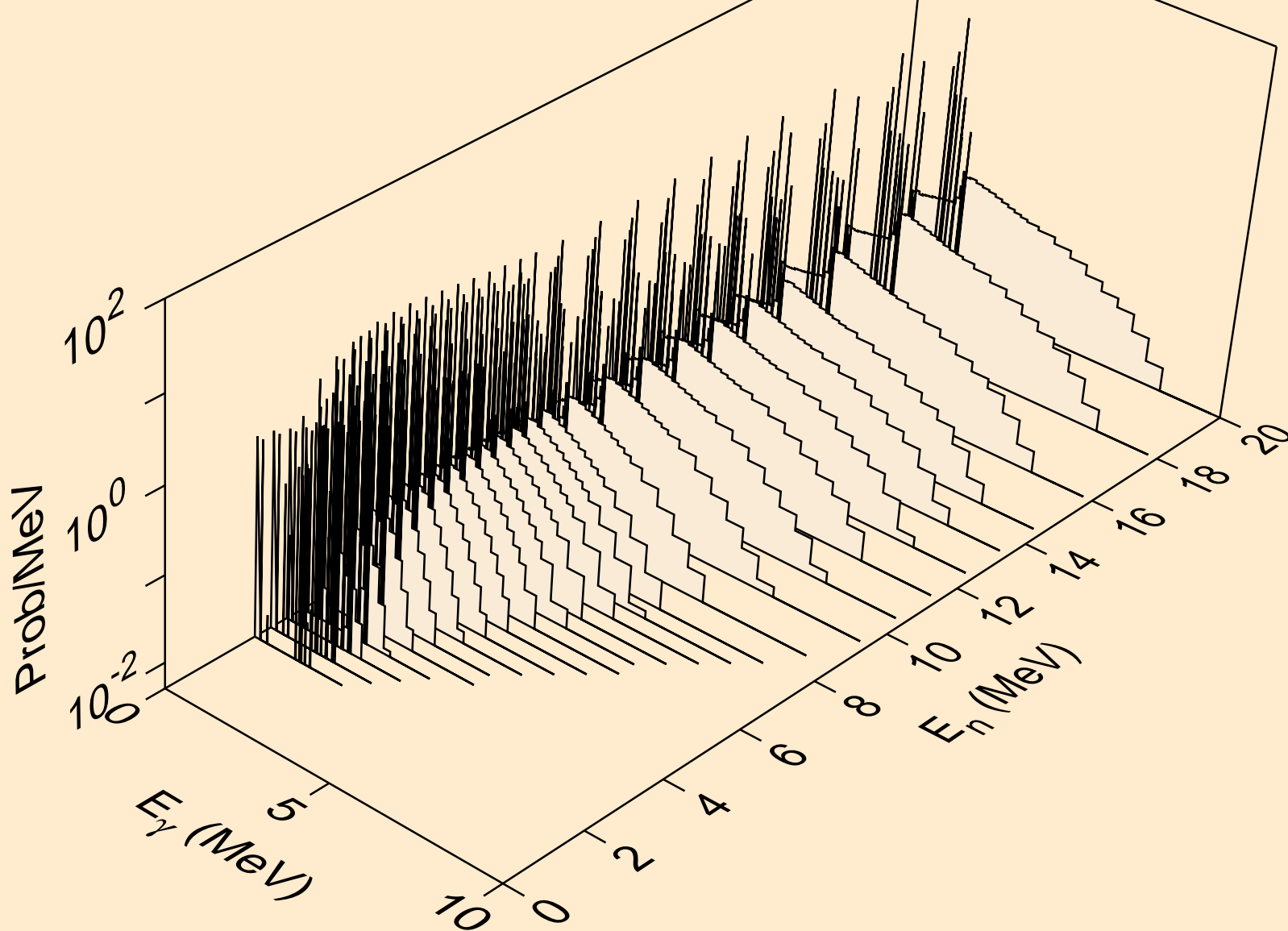

21-SC-45 FOR FENDL-3.1 FROM JEFF-3.1.1 WITH NJOY2012.50+  
Photon emission for (n,d\*1)

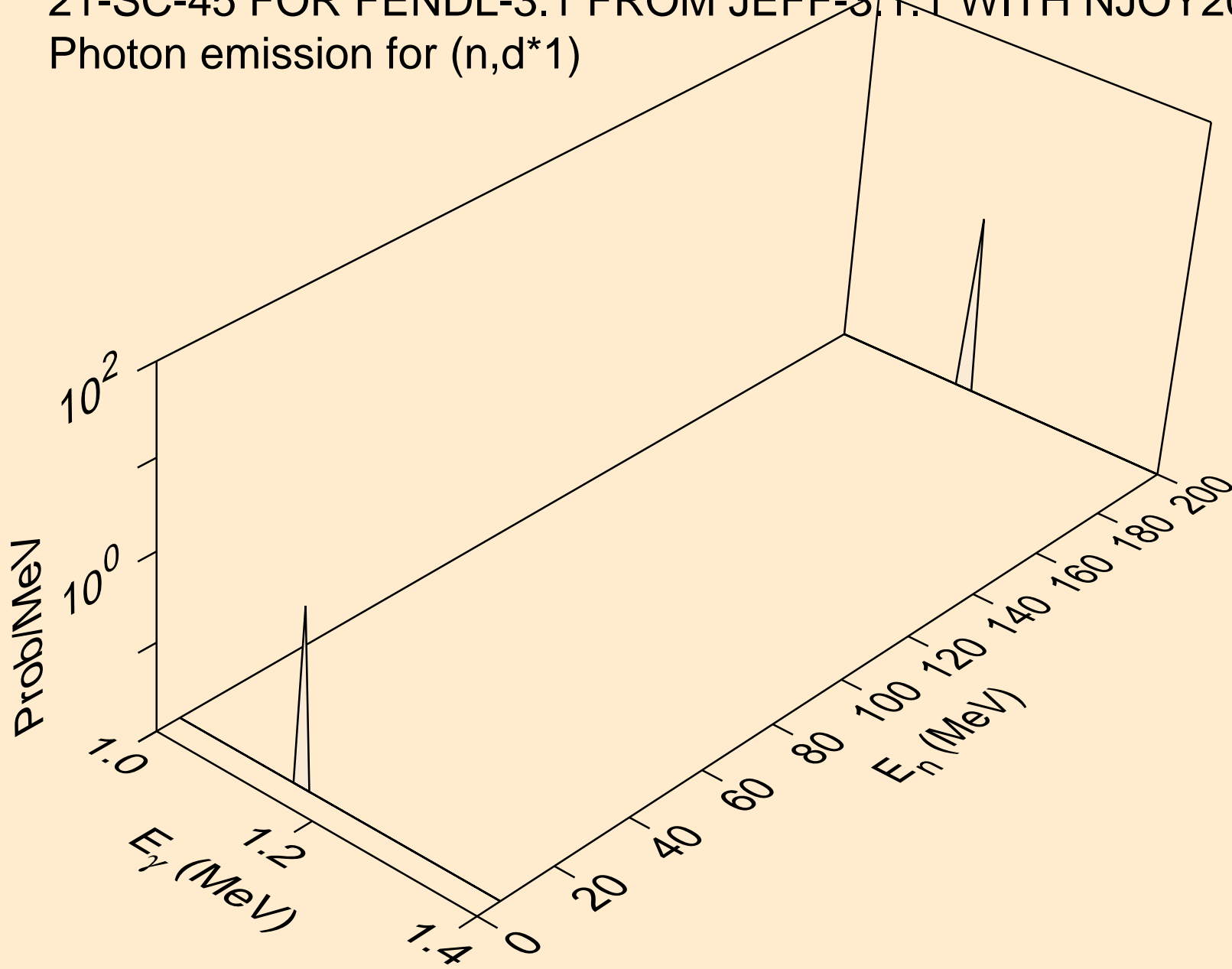

21-SC-45 FOR FENDL-3.1 FROM JEFF-3.1.1 WITH NJOY2012.50+  
Photon emission for (n,d\*2)

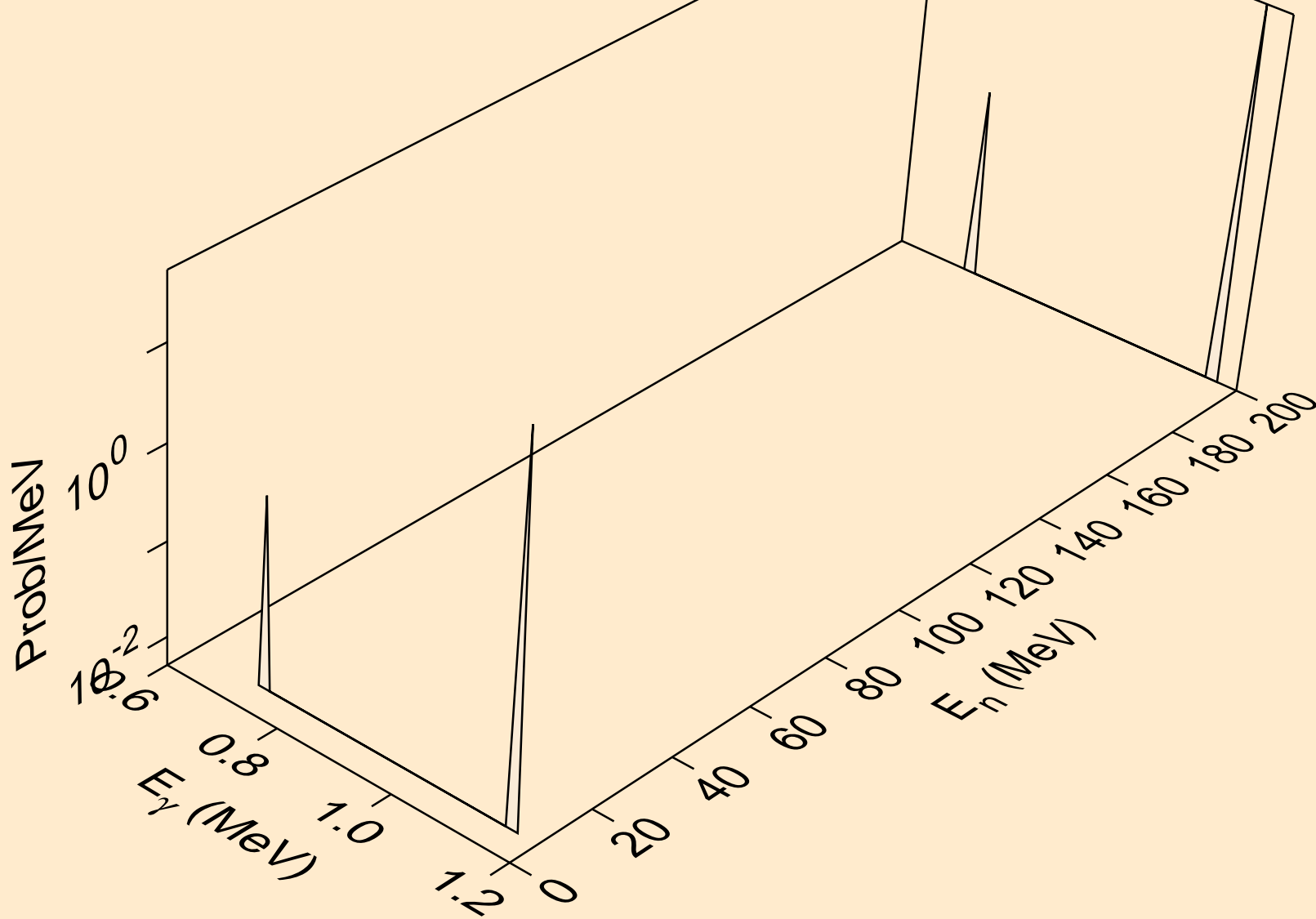



21-SC-45 FOR FENDL-3.1 FROM JEFF-3.1.1 WITH NJOY2012.50+  
Photon emission for (n,d\*3)

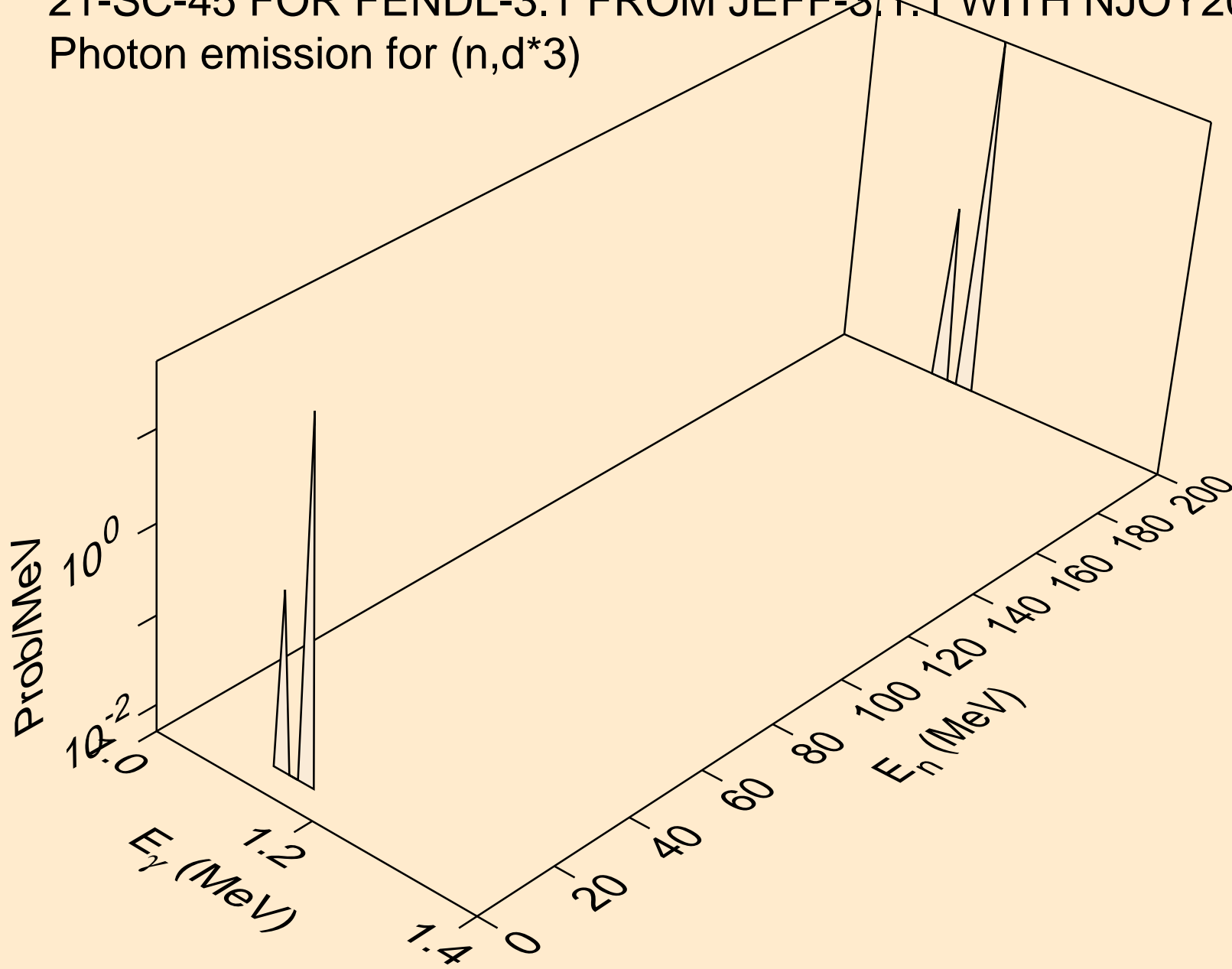

21-SC-45 FOR FENDL-3.1 FROM JEFF-3.1.1 WITH NJOY2012.50+  
Photon emission for (n,d\*4)

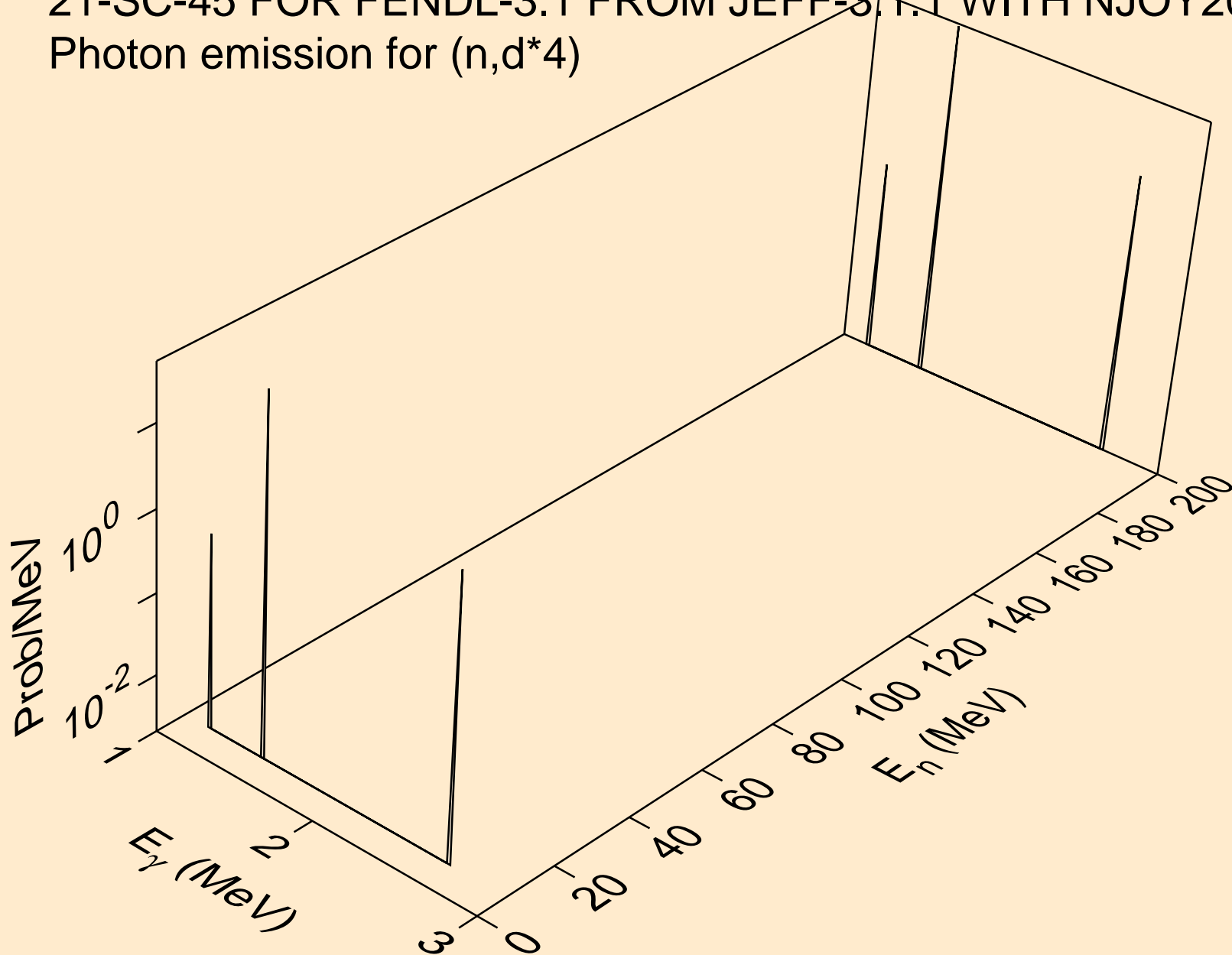

21-SC-45 FOR FENDL-3.1 FROM JEFF-3.1.1 WITH NJOY2012.50+  
Photon emission for (n,d\*5)

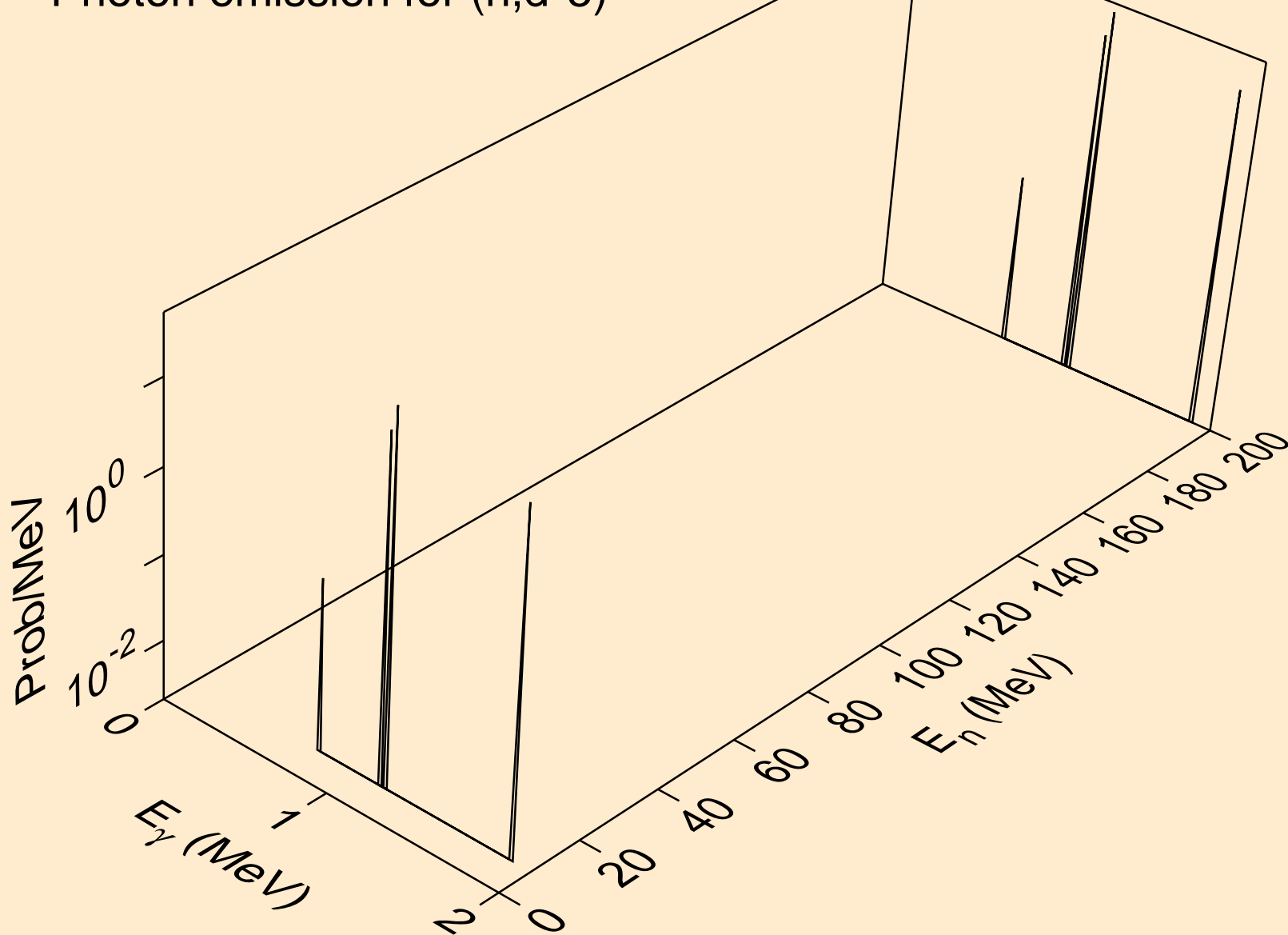

21-SC-45 FOR FENDL-3.1 FROM JEFF-3.1.1 WITH NJOY2012.50+  
Photon emission for (n,d\*c)

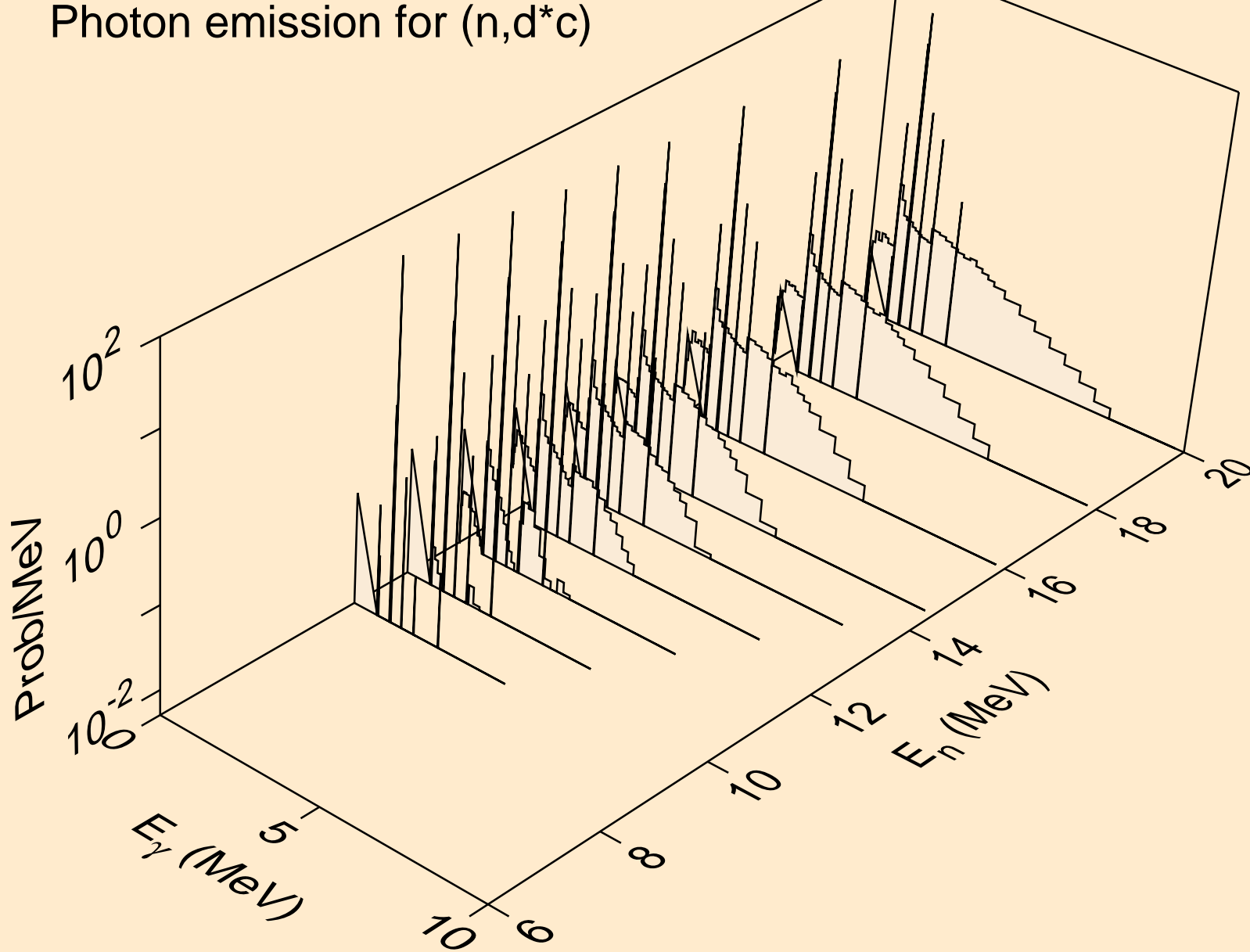

21-SC-45 FOR FENDL-3.1 FROM JEFF-3.1.1 WITH NJOY2012.50+  
Photon emission for (n,t\*1)

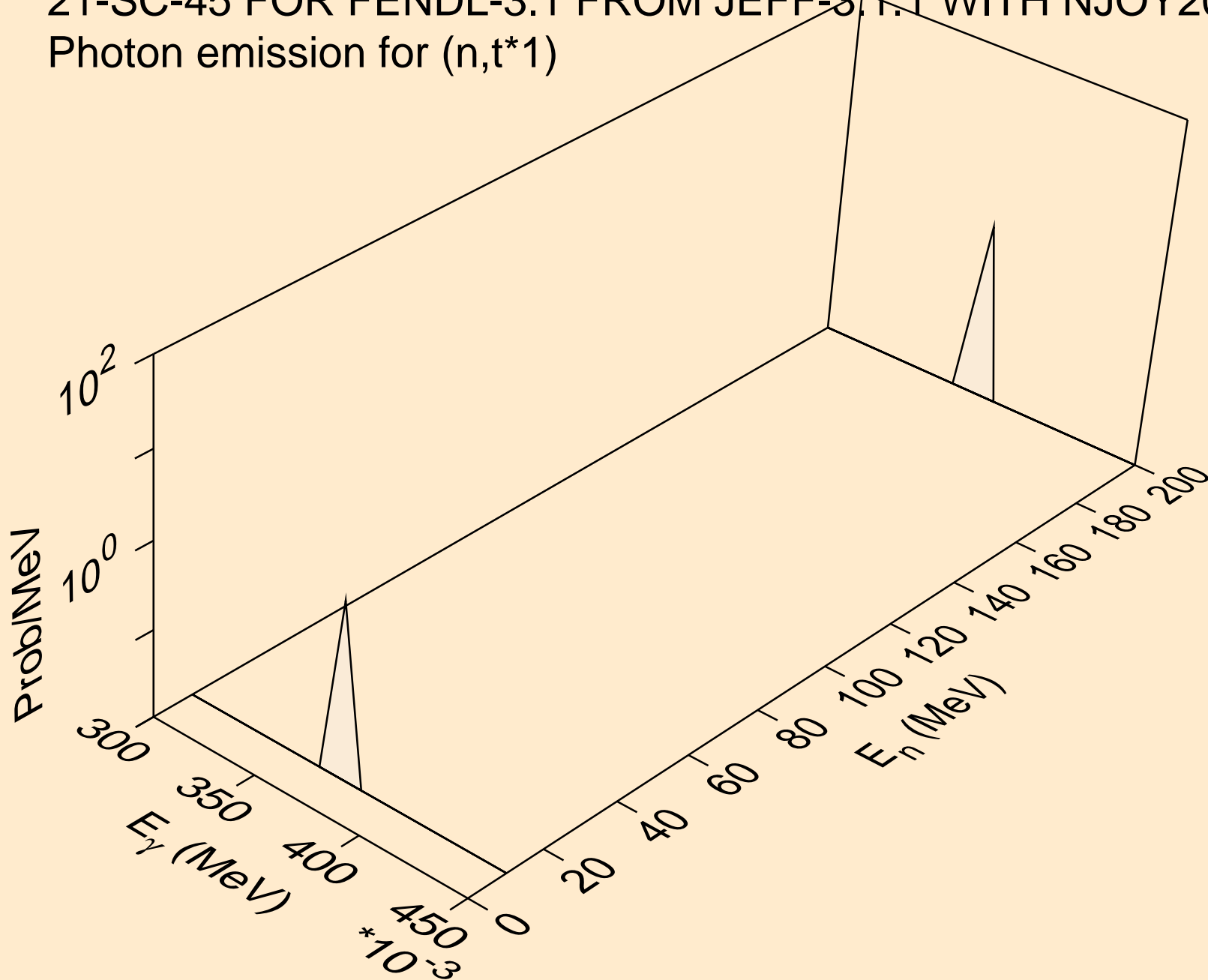

21-SC-45 FOR FENDL-3.1 FROM JEFF-3.1.1 WITH NJOY2012.50+  
Photon emission for (n,t\*2)

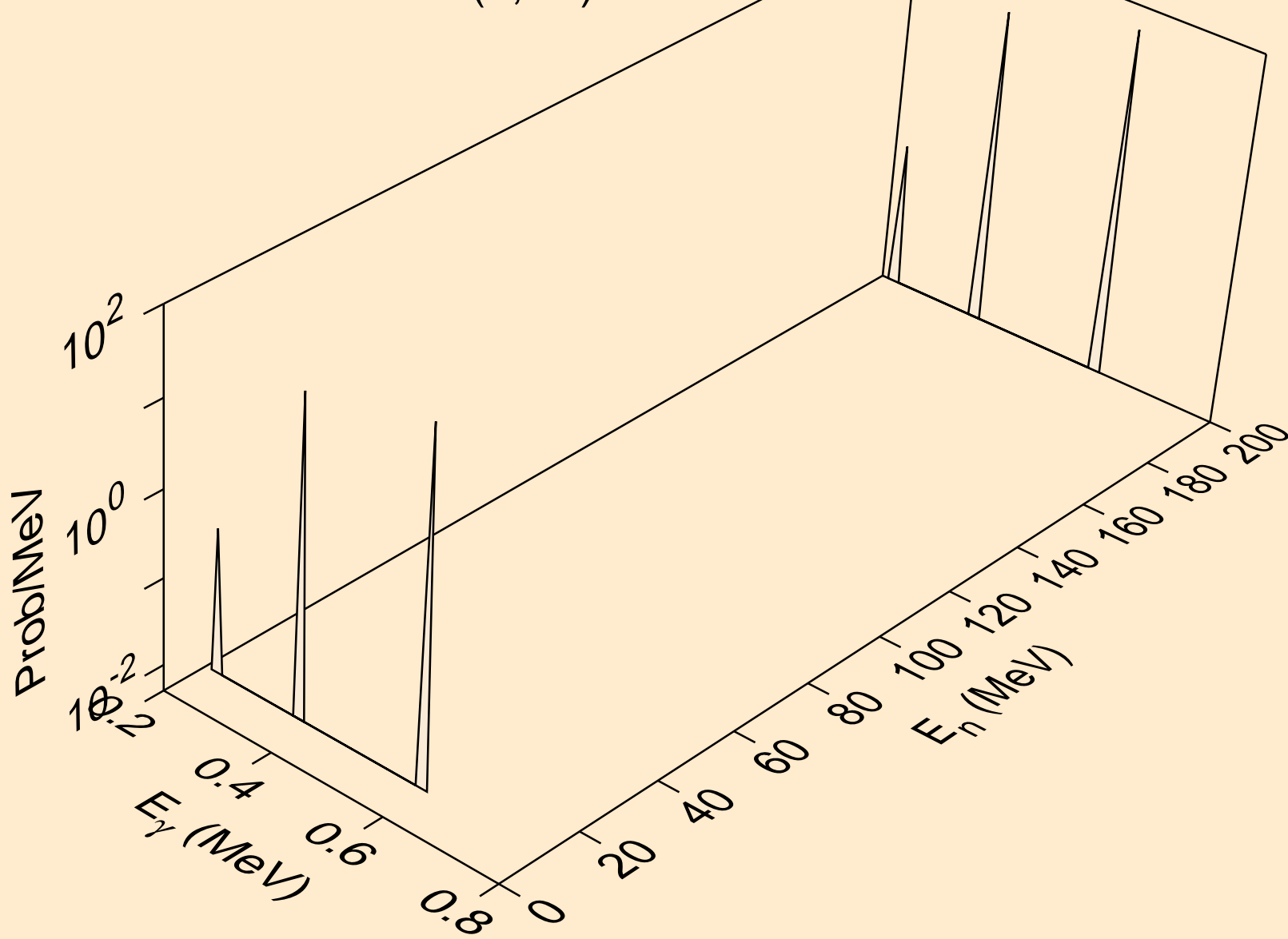

21-SC-45 FOR FENDL-3.1 FROM JEFF-3.1.1 WITH NJOY2012.50+  
Photon emission for (n,t\*3)

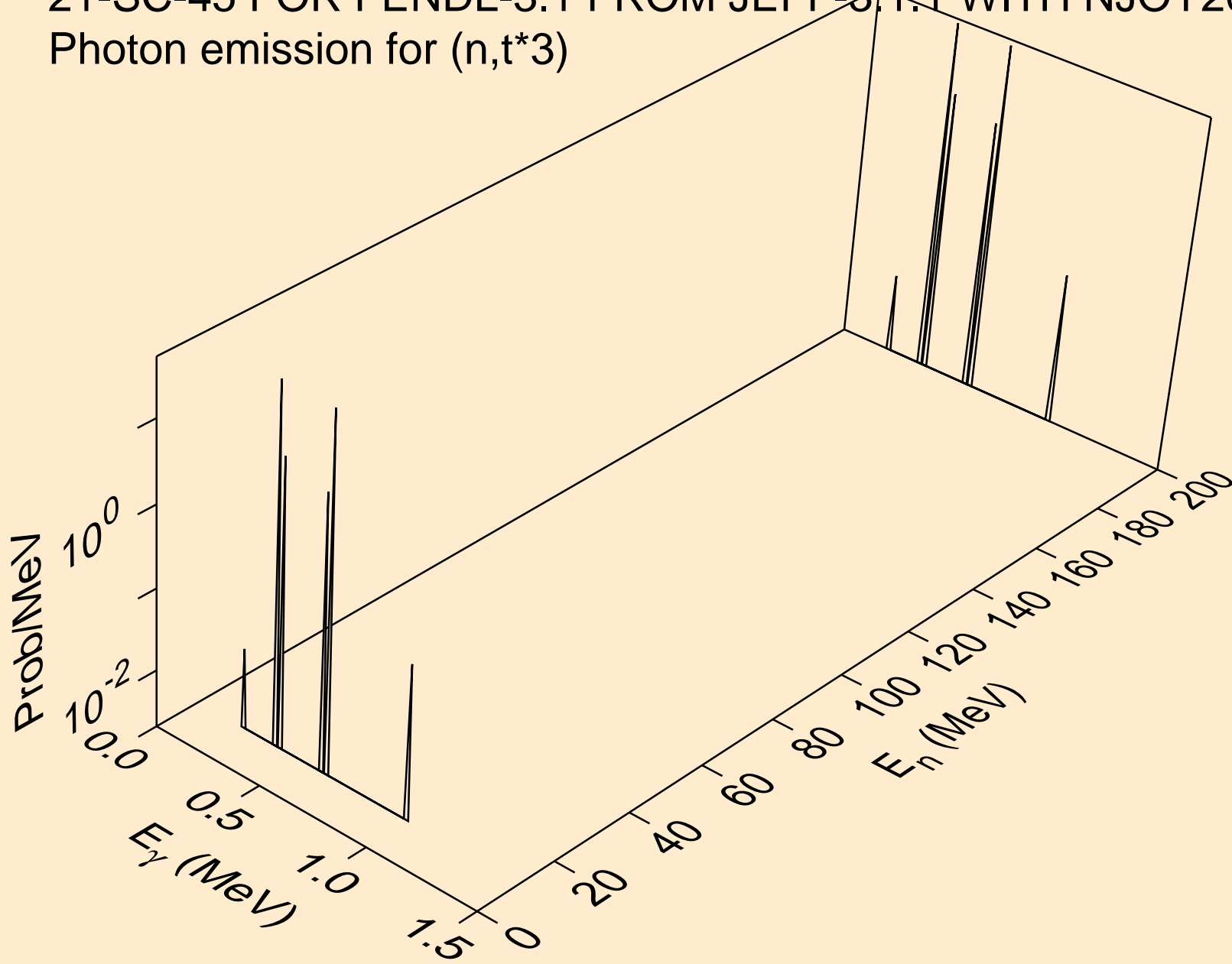

21-SC-45 FOR FENDL-3.1 FROM JEFF-3.1.1 WITH NJOY2012.50+  
Photon emission for (n,t\*4)

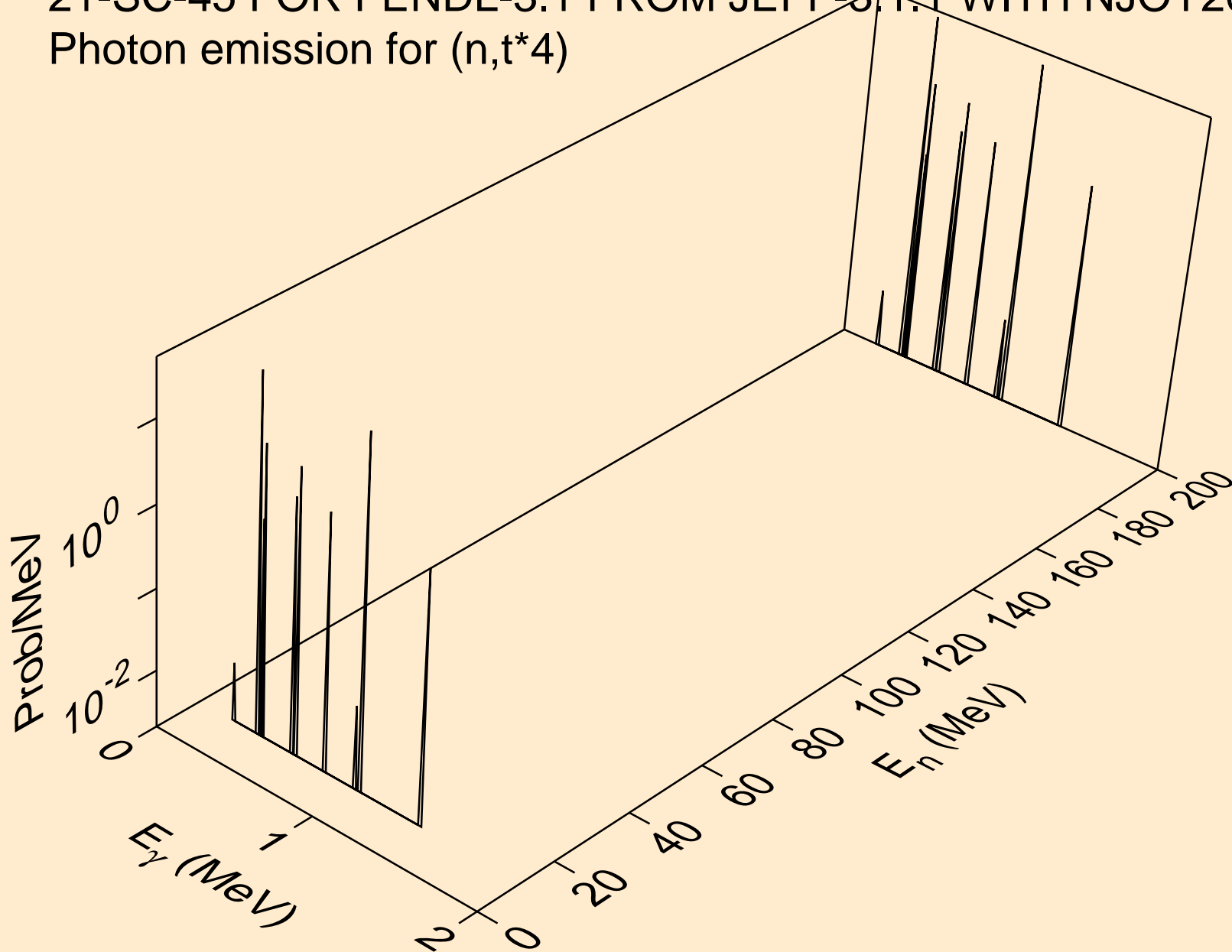



21-SC-45 FOR FENDL-3.1 FROM JEFF-3.1.1 WITH NJOY2012.50+  
Photon emission for (n,t\*5)

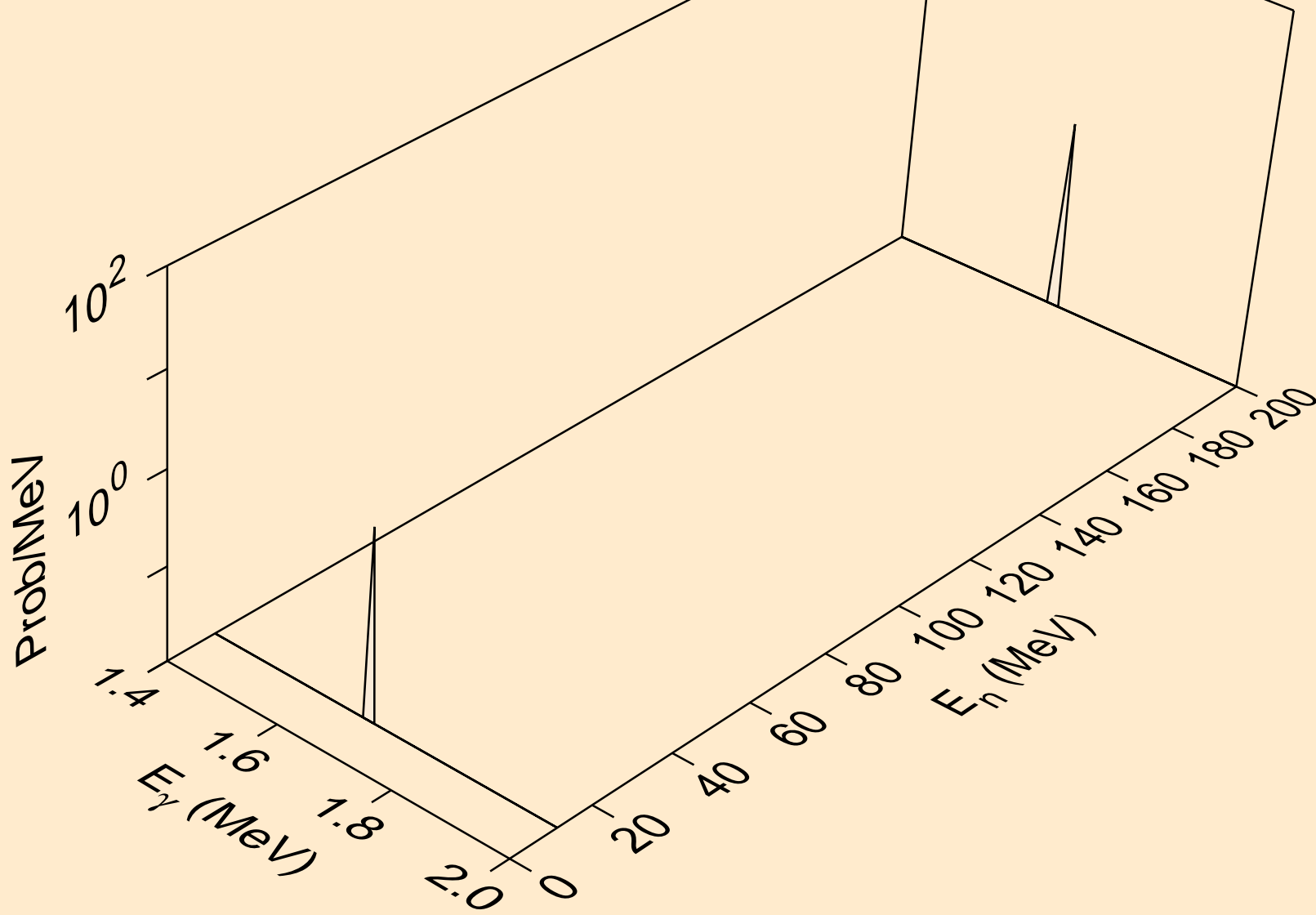

21-SC-45 FOR FENDL-3.1 FROM JEFF-3.1.1 WITH NJOY2012.50+  
Photon emission for (n,t\*c)

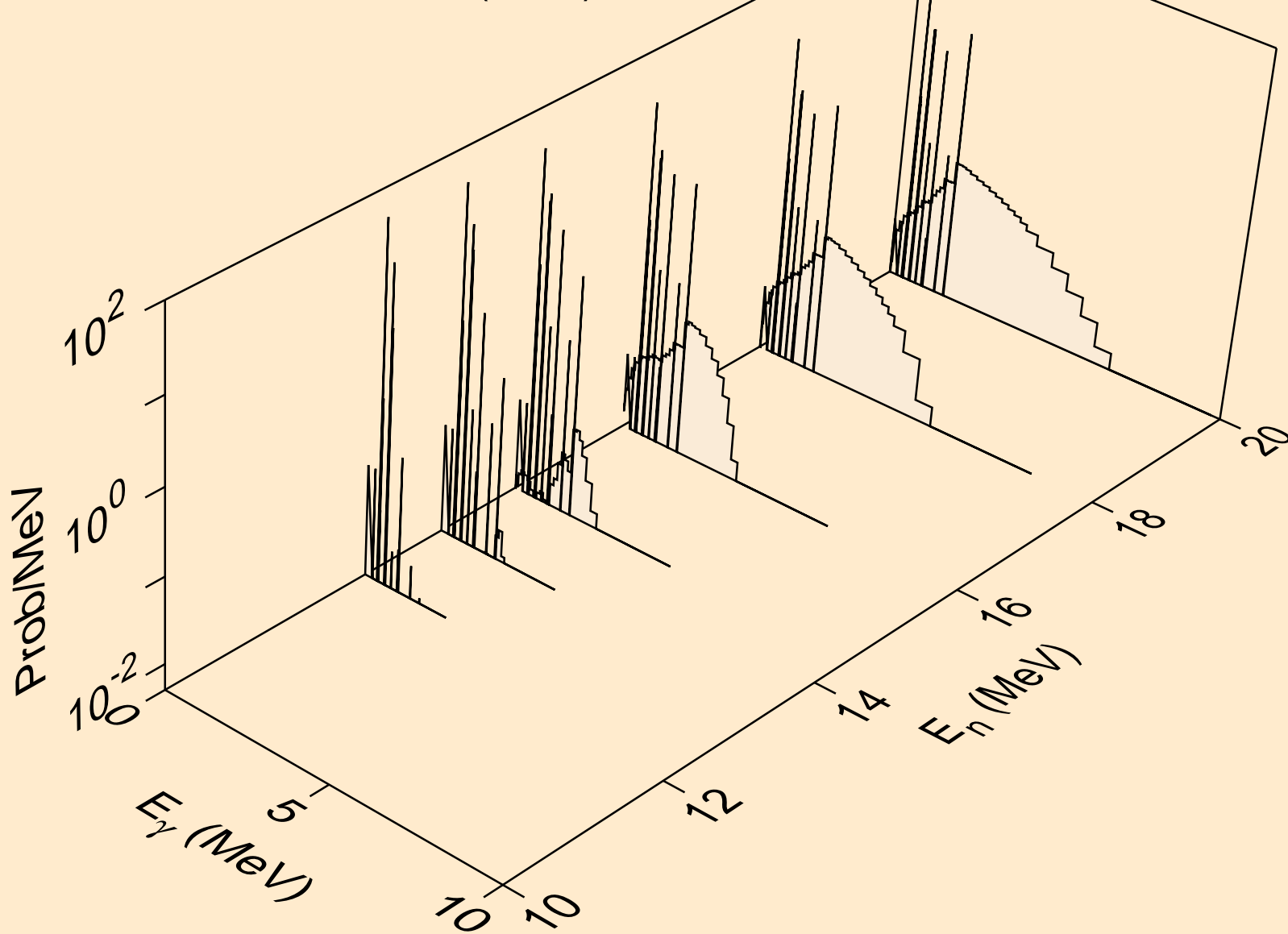

21-SC-45 FOR FENDL-3.1 FROM JEFF-3.1.1 WITH NJOY2012.50+  
Photon emission for (n,he3\*1)

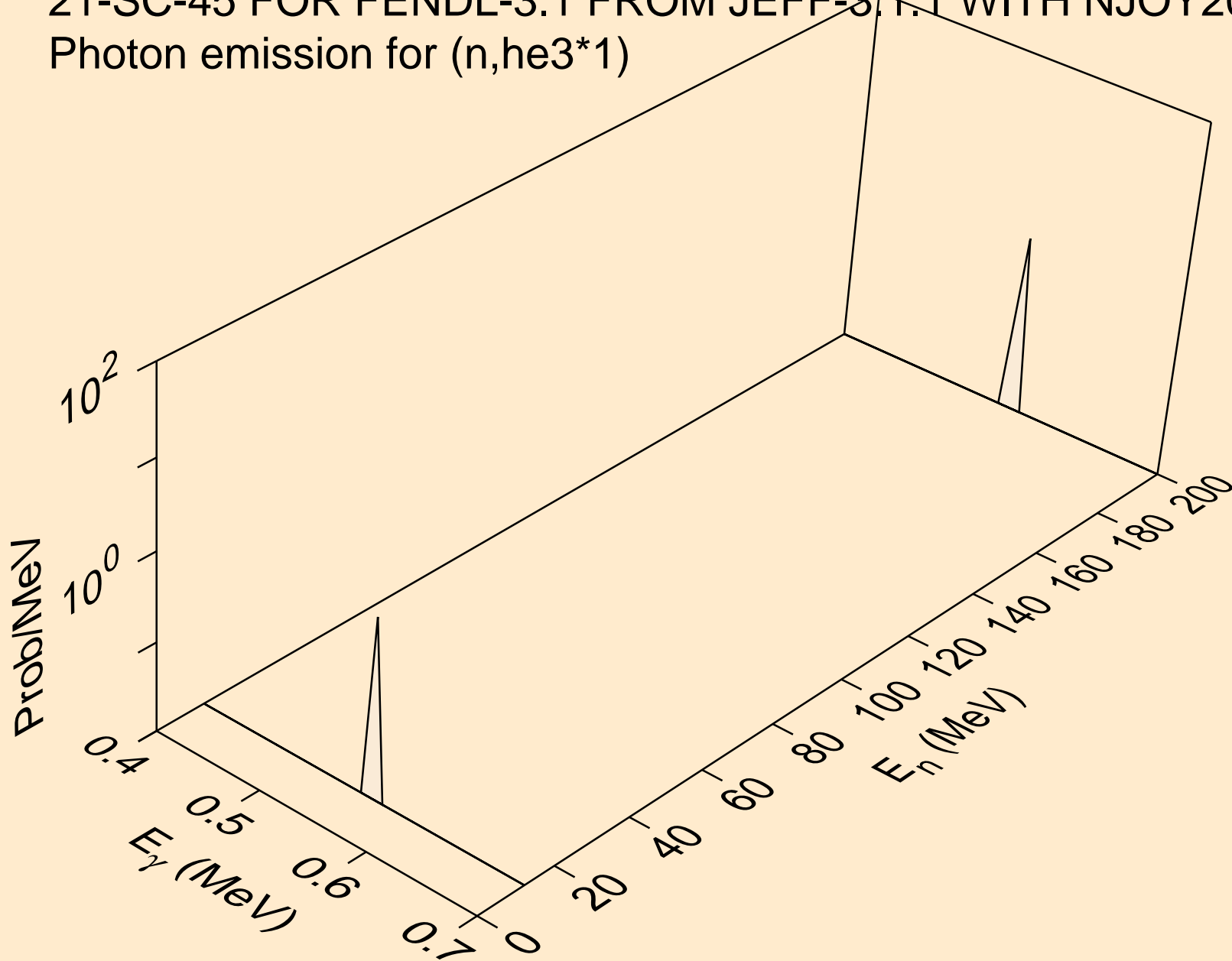

21-SC-45 FOR FENDL-3.1 FROM JEFF-3.1.1 WITH NJOY2012.50+  
Photon emission for (n,he3\*2)

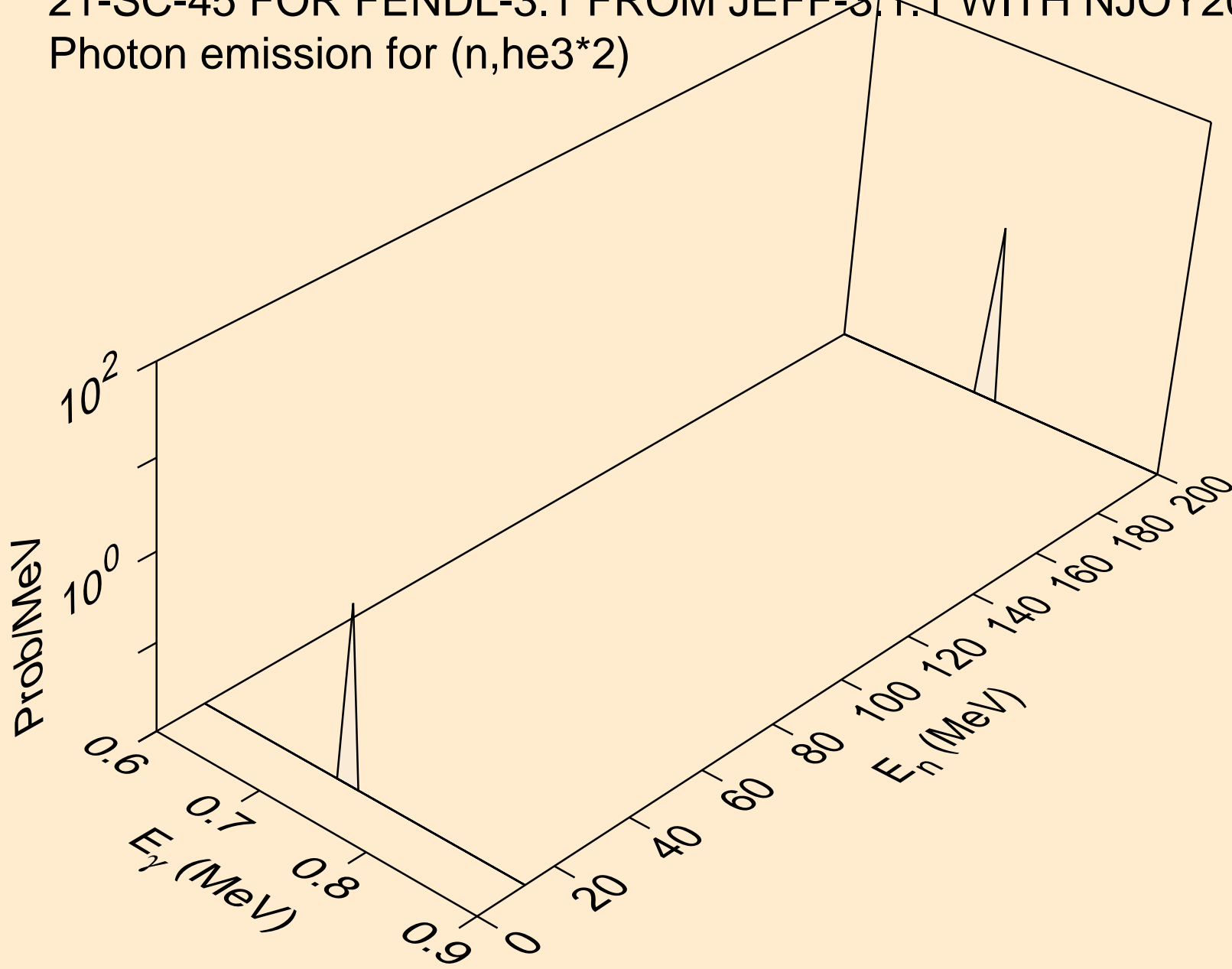

21-SC-45 FOR FENDL-3.1 FROM JEFF-3.1.1 WITH NJOY2012.50+  
Photon emission for (n,he3\*3)

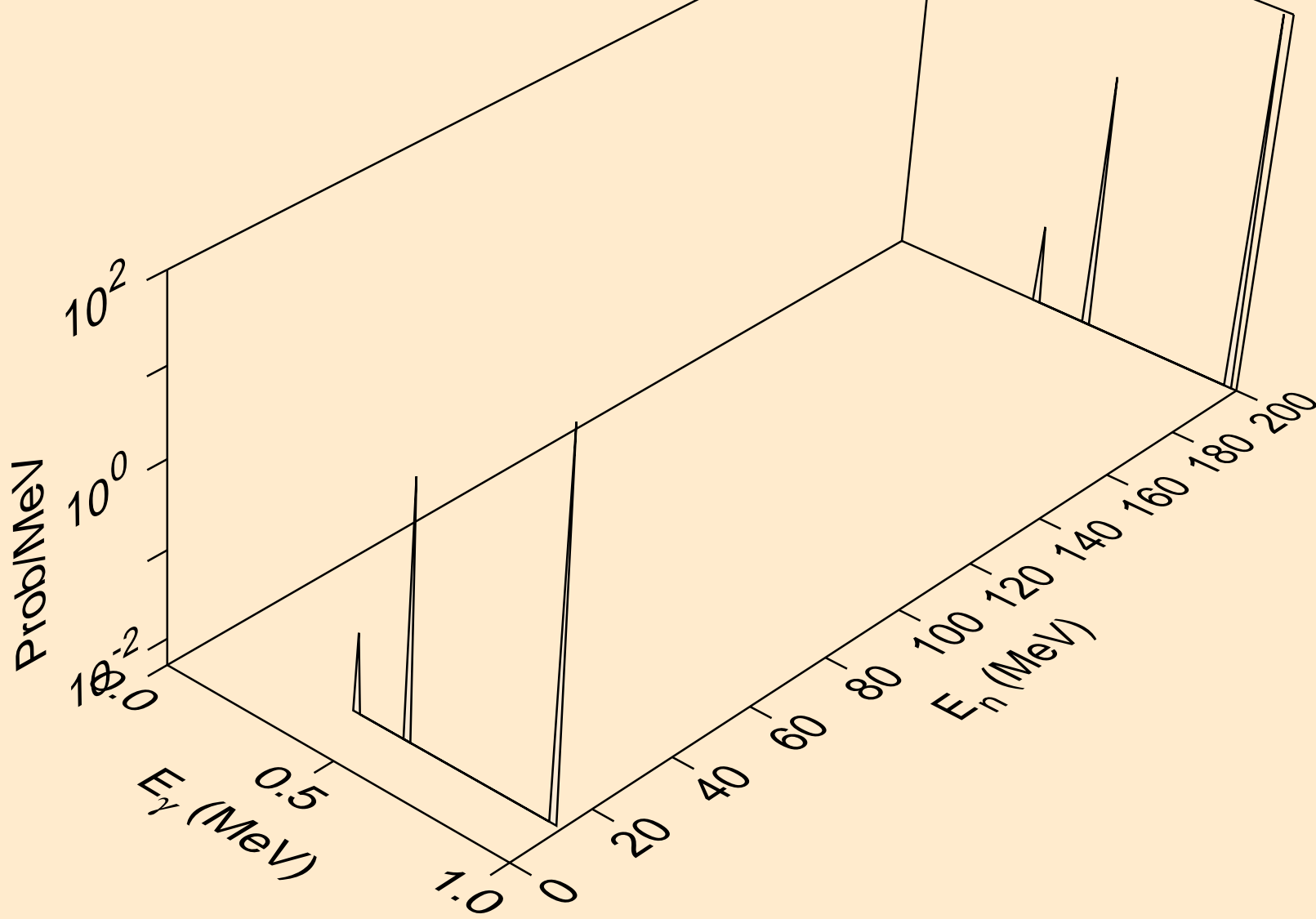

21-SC-45 FOR FENDL-3.1 FROM JEFF-3.1.1 WITH NJOY2012.50+  
Photon emission for (n,he3\*4)

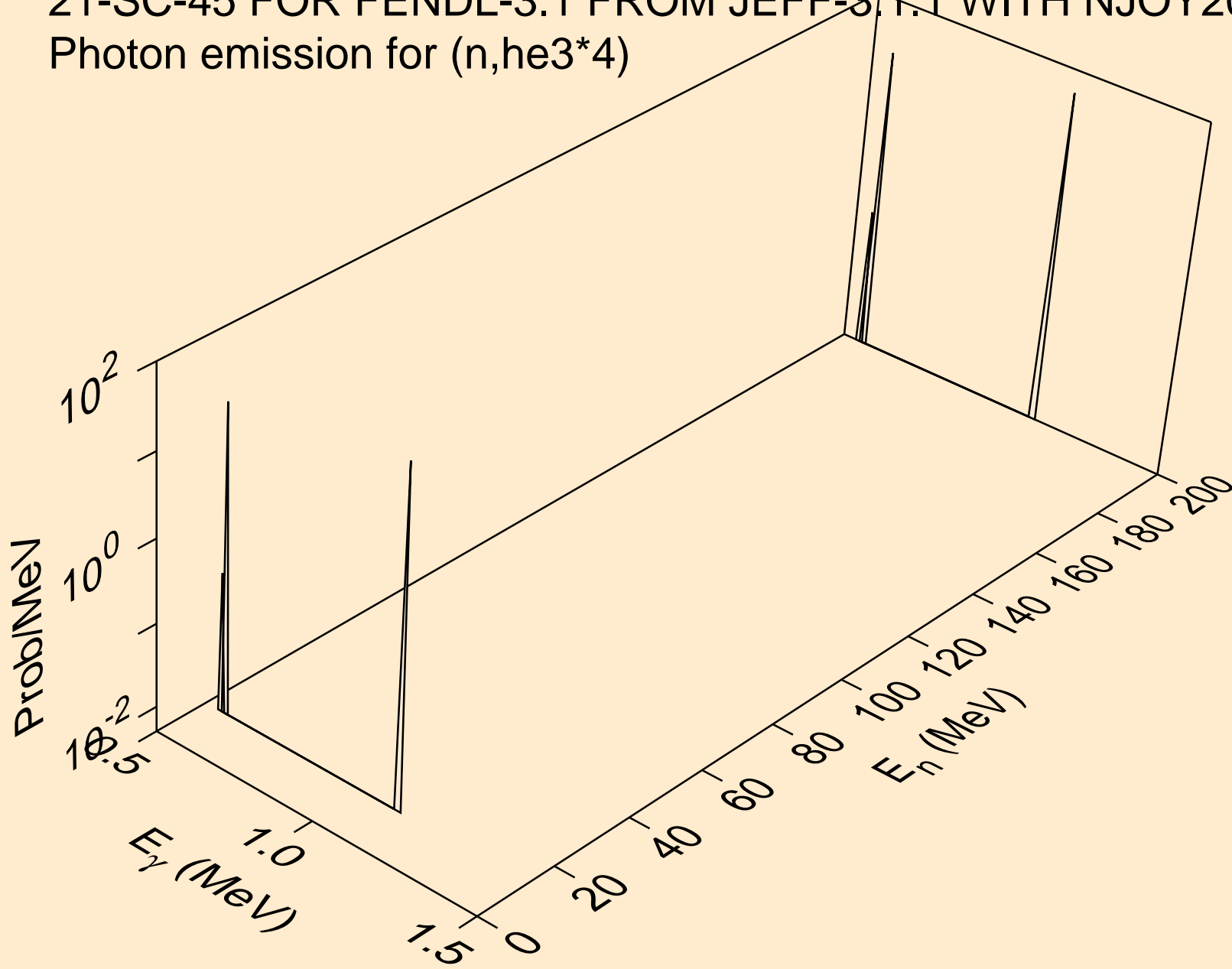

21-SC-45 FOR FENDL-3.1 FROM JEFF-3.1.1 WITH NJOY2012.50+  
Photon emission for (n,he3\*5)

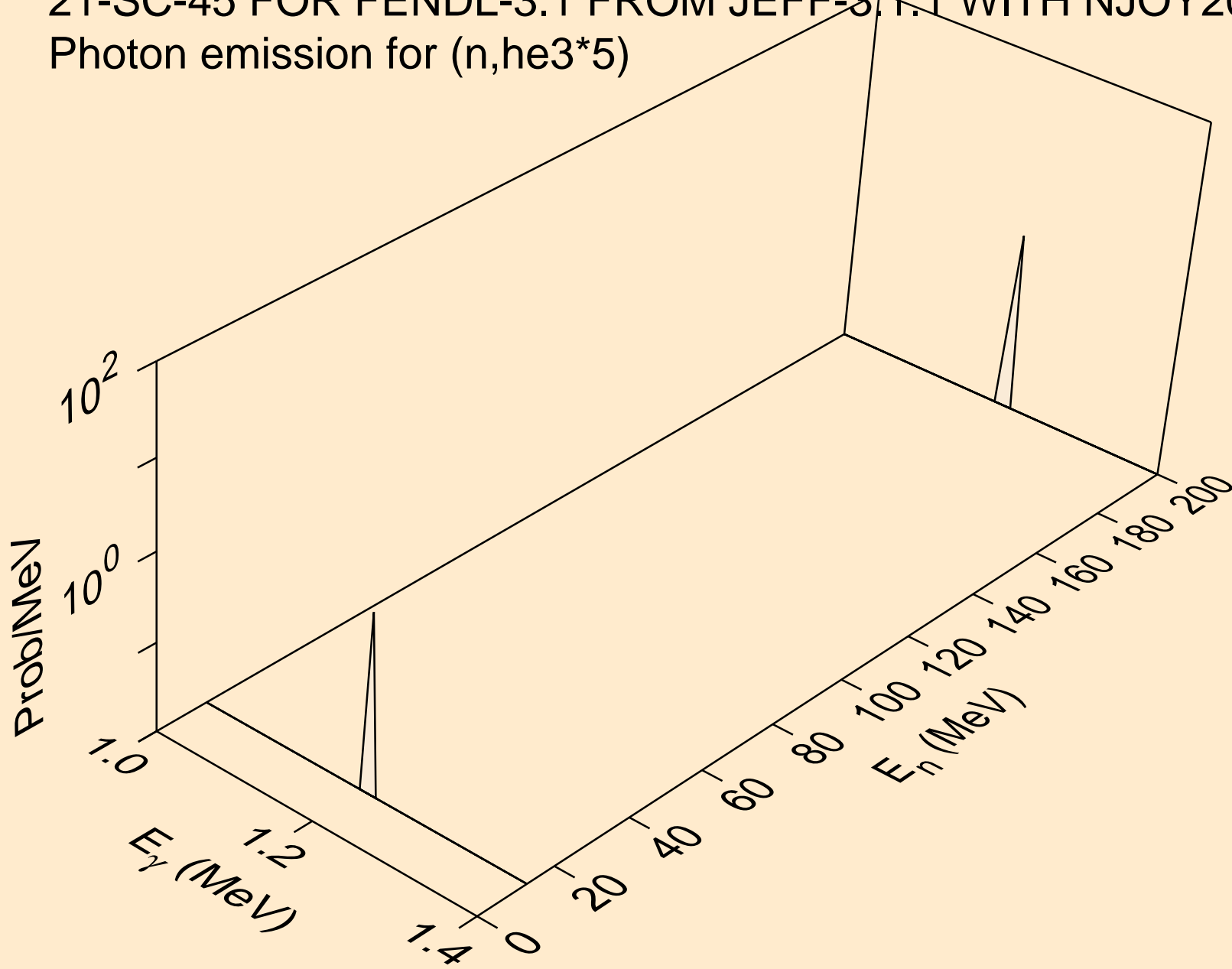

21-SC-45 FOR FENDL-3.1 FROM JEFF-3.1.1 WITH NJOY2012.50+  
Photon emission for (n,he3\*c)

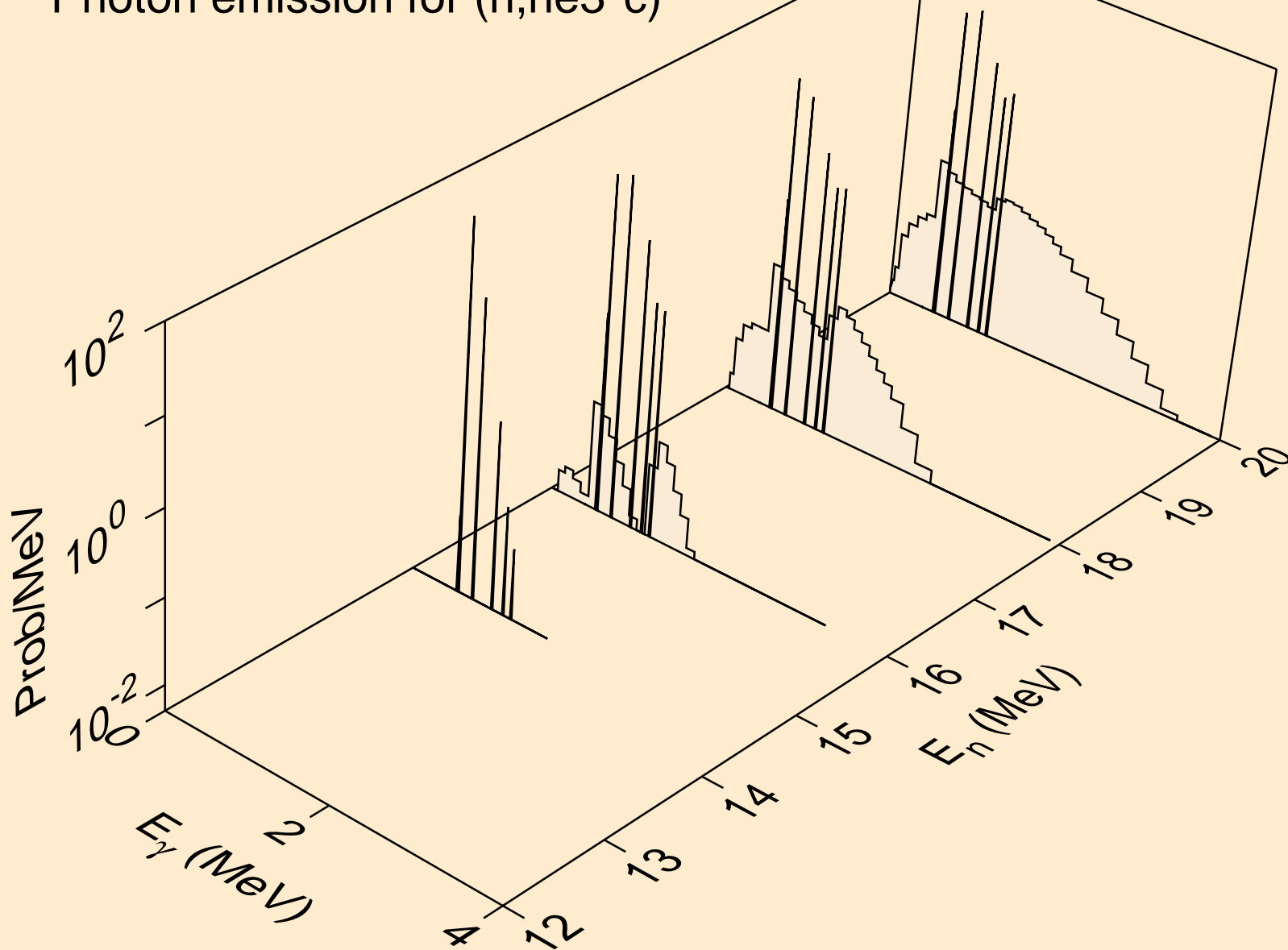



21-SC-45 FOR FENDL-3.1 FROM JEFF-3.1.1 WITH NJOY2012.50+  
Photon emission for (n,a\*1)

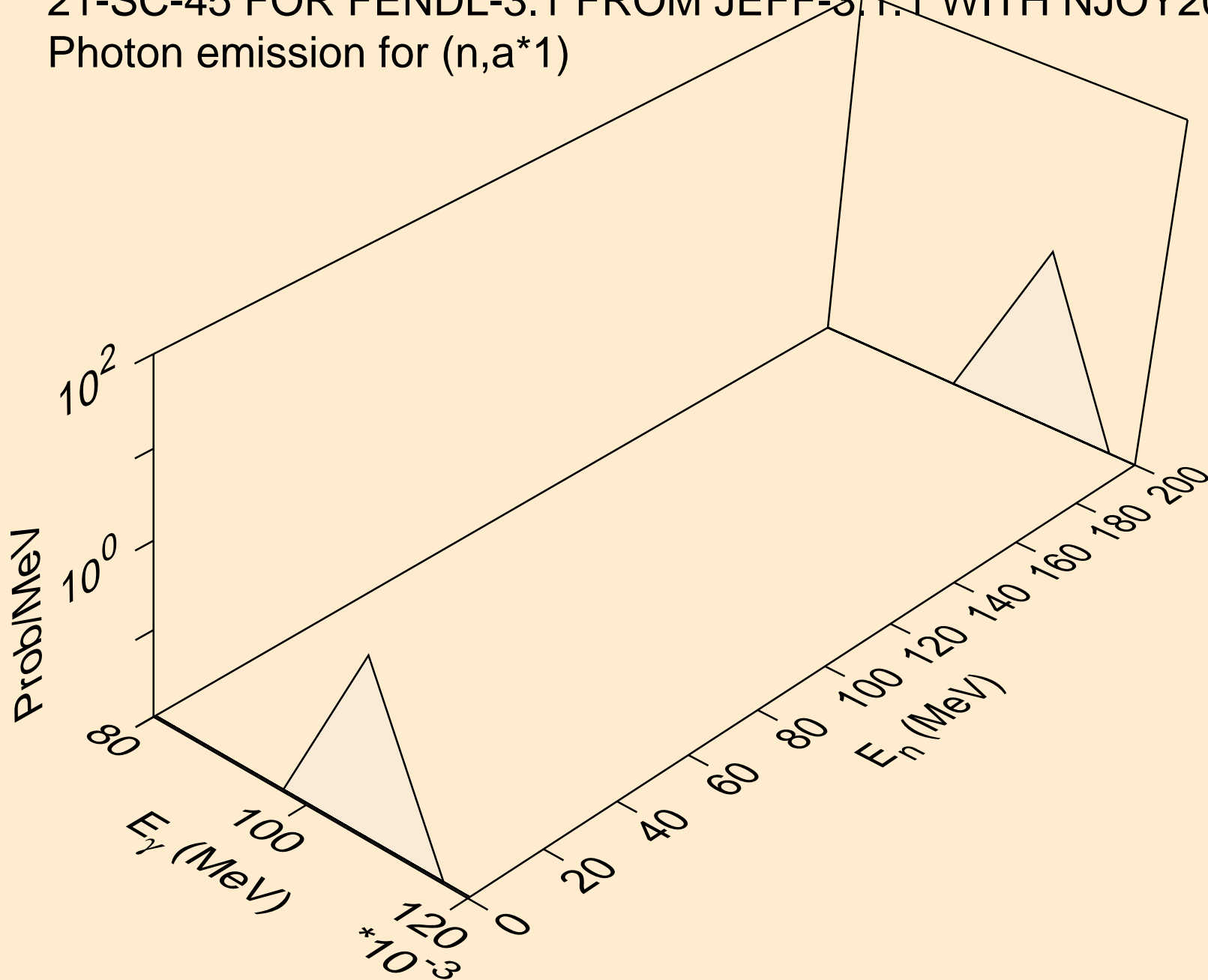

21-SC-45 FOR FENDL-3.1 FROM JEFF-3.1.1 WITH NJOY2012.50+  
Photon emission for (n,a\*2)

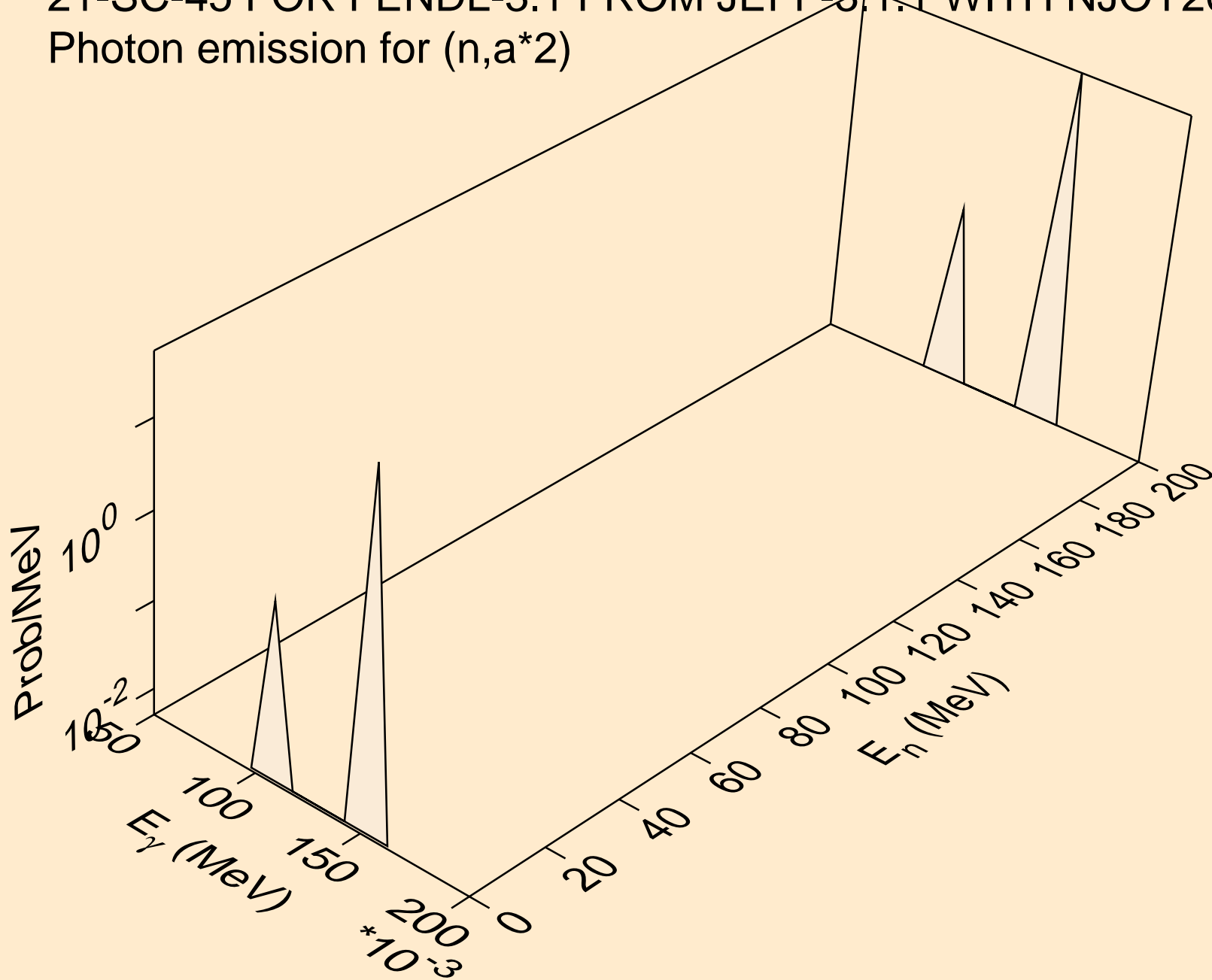

21-SC-45 FOR FENDL-3.1 FROM JEFF-3.1.1 WITH NJOY2012.50+  
Photon emission for (n,a\*3)

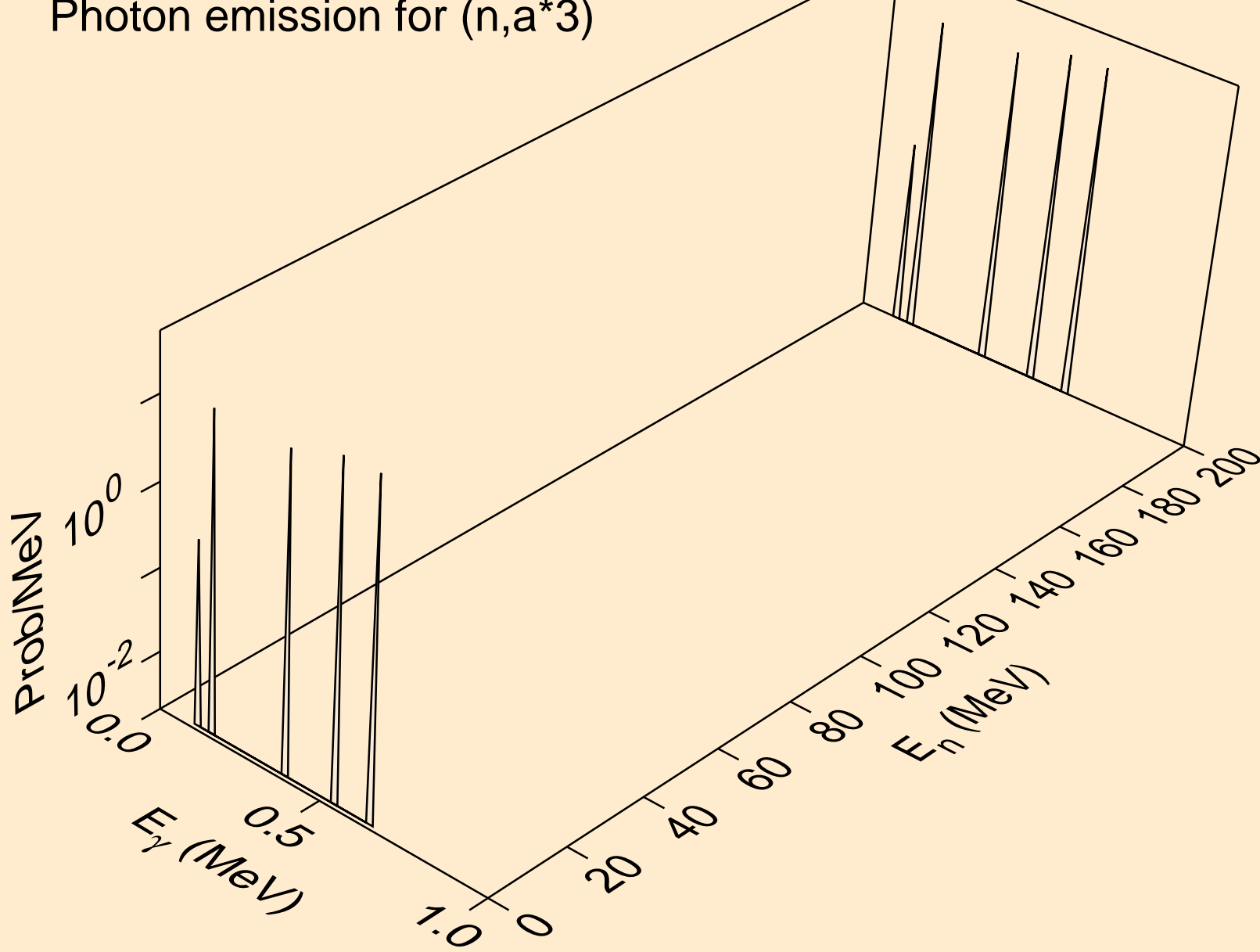

21-SC-45 FOR FENDL-3.1 FROM JEFF-3.1.1 WITH NJOY2012.50+  
Photon emission for (n,a\*4)

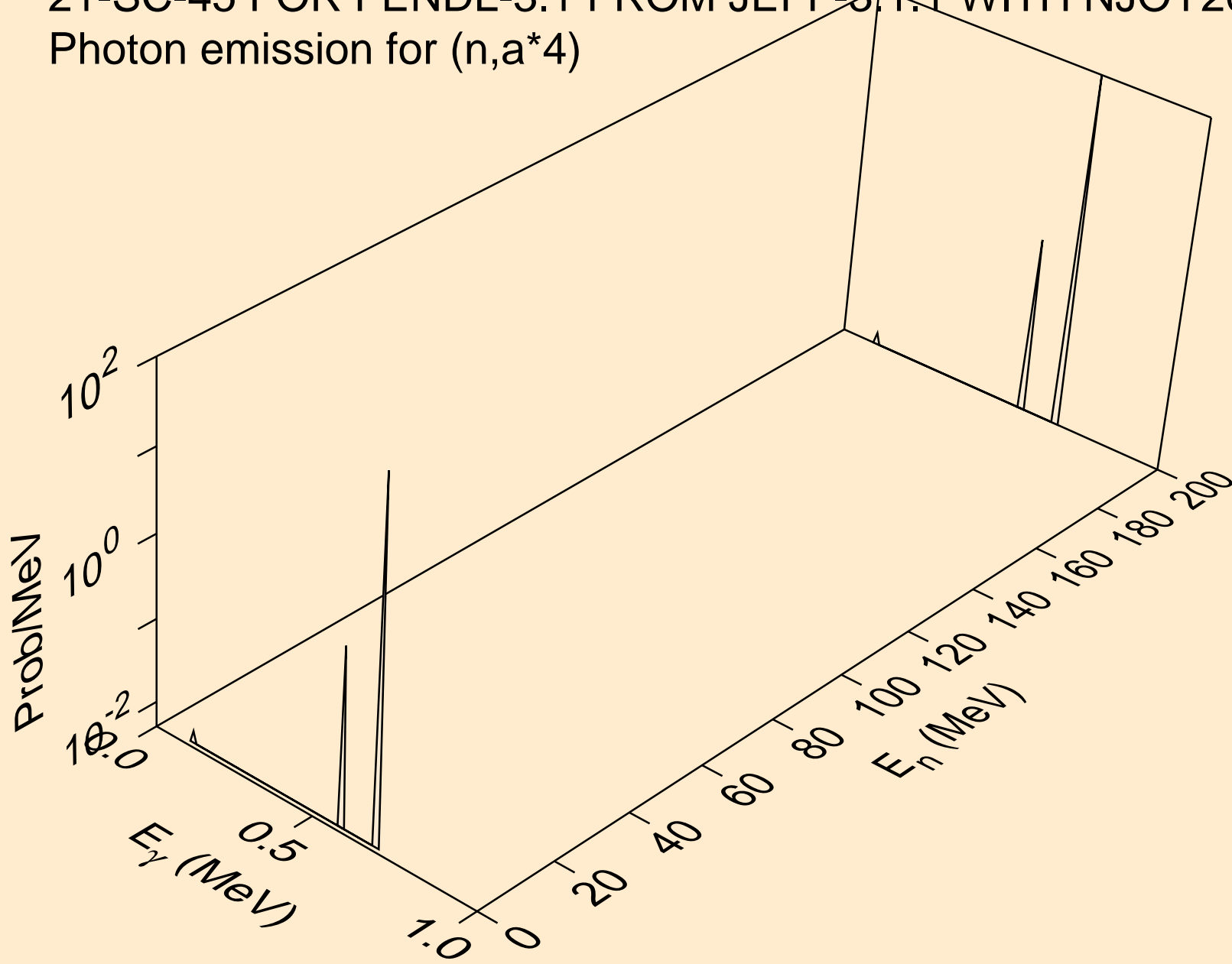

21-SC-45 FOR FENDL-3.1 FROM JEFF-3.1.1 WITH NJOY2012.50+  
Photon emission for (n,a\*5)

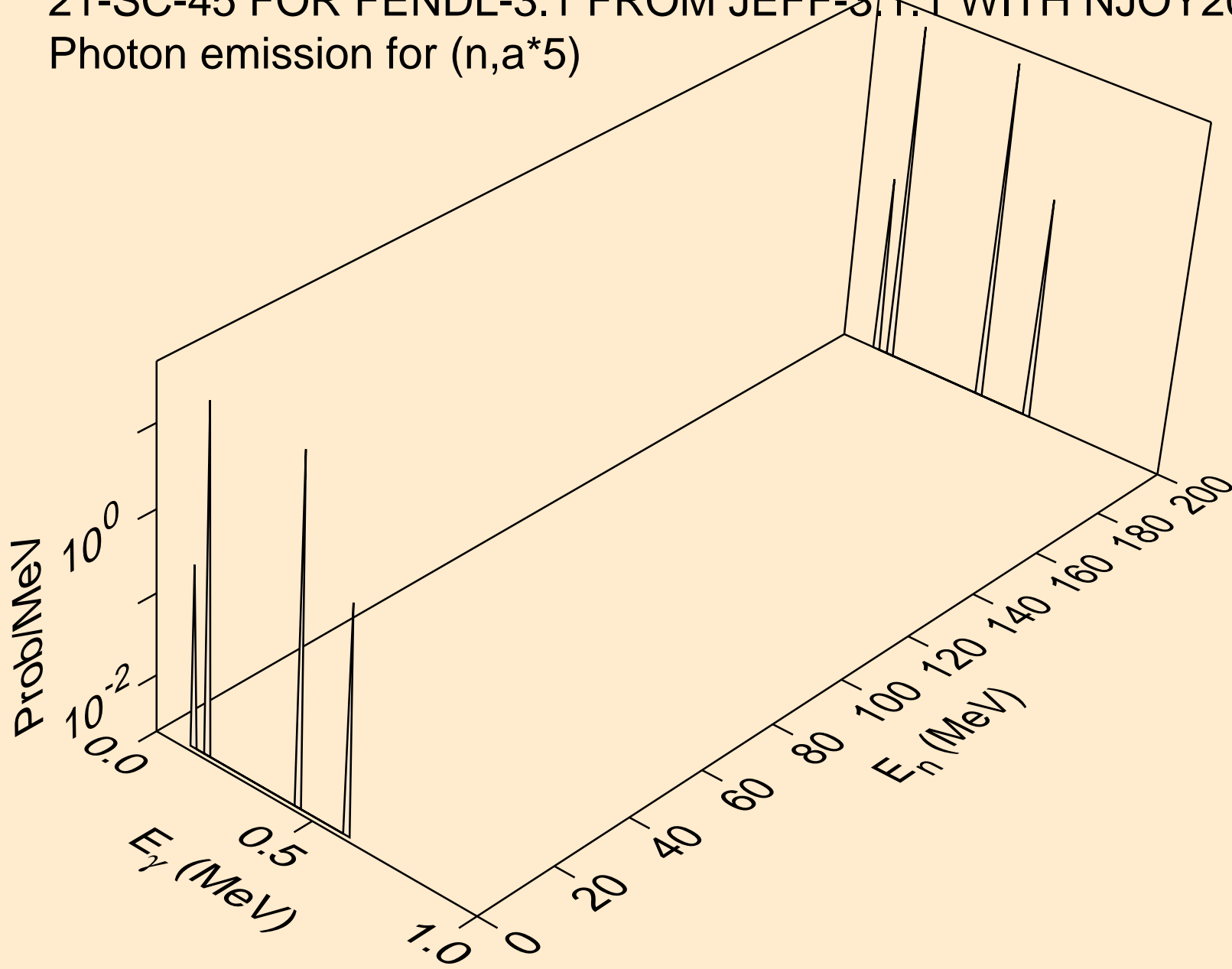

21-SC-45 FOR FENDL-3.1 FROM JEFF-3.1.1 WITH NJOY2012.50+  
Photon emission for (n,a\*6)

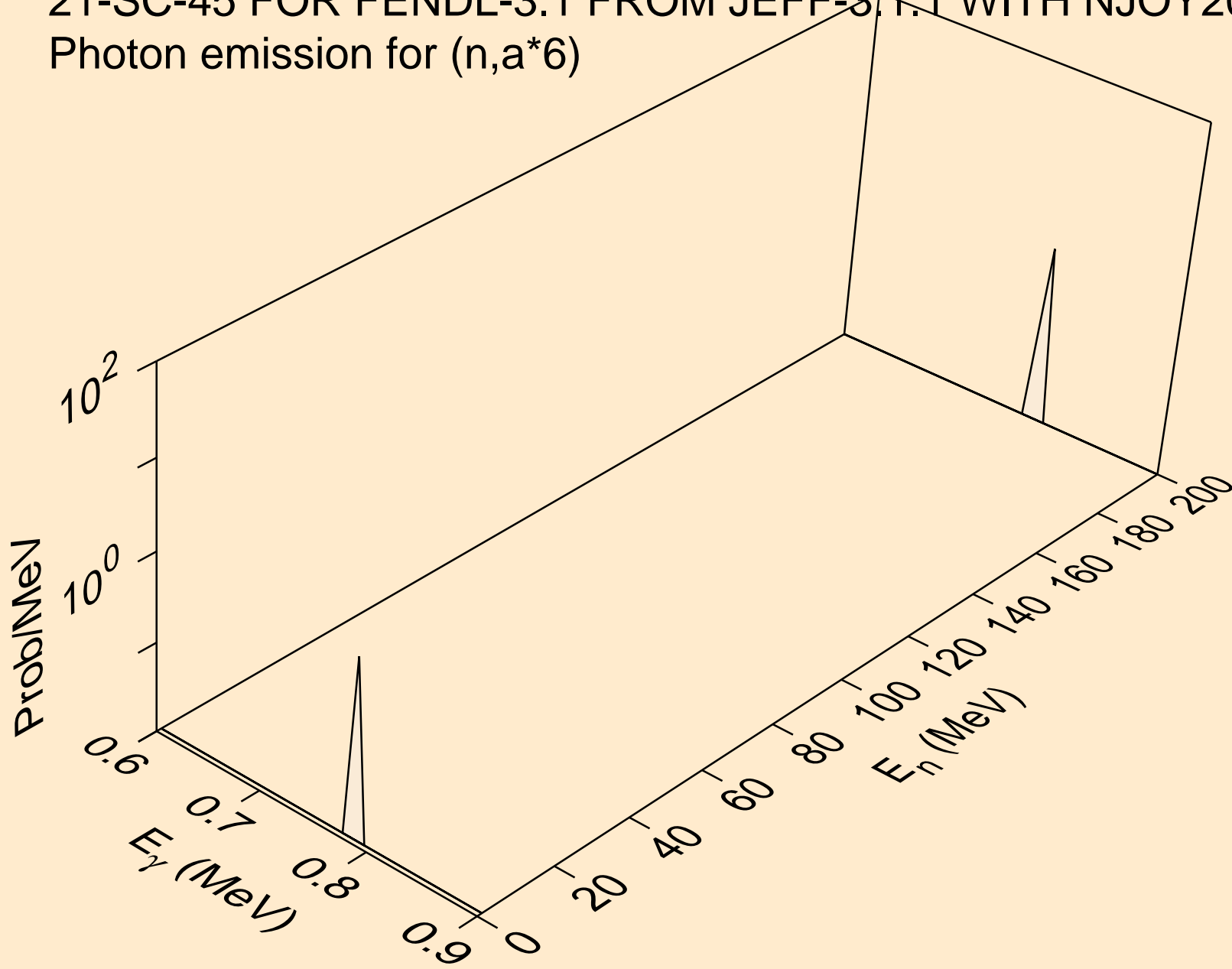

21-SC-45 FOR FENDL-3.1 FROM JEFF-3.1.1 WITH NJOY2012.50+  
Photon emission for (n,a\*7)

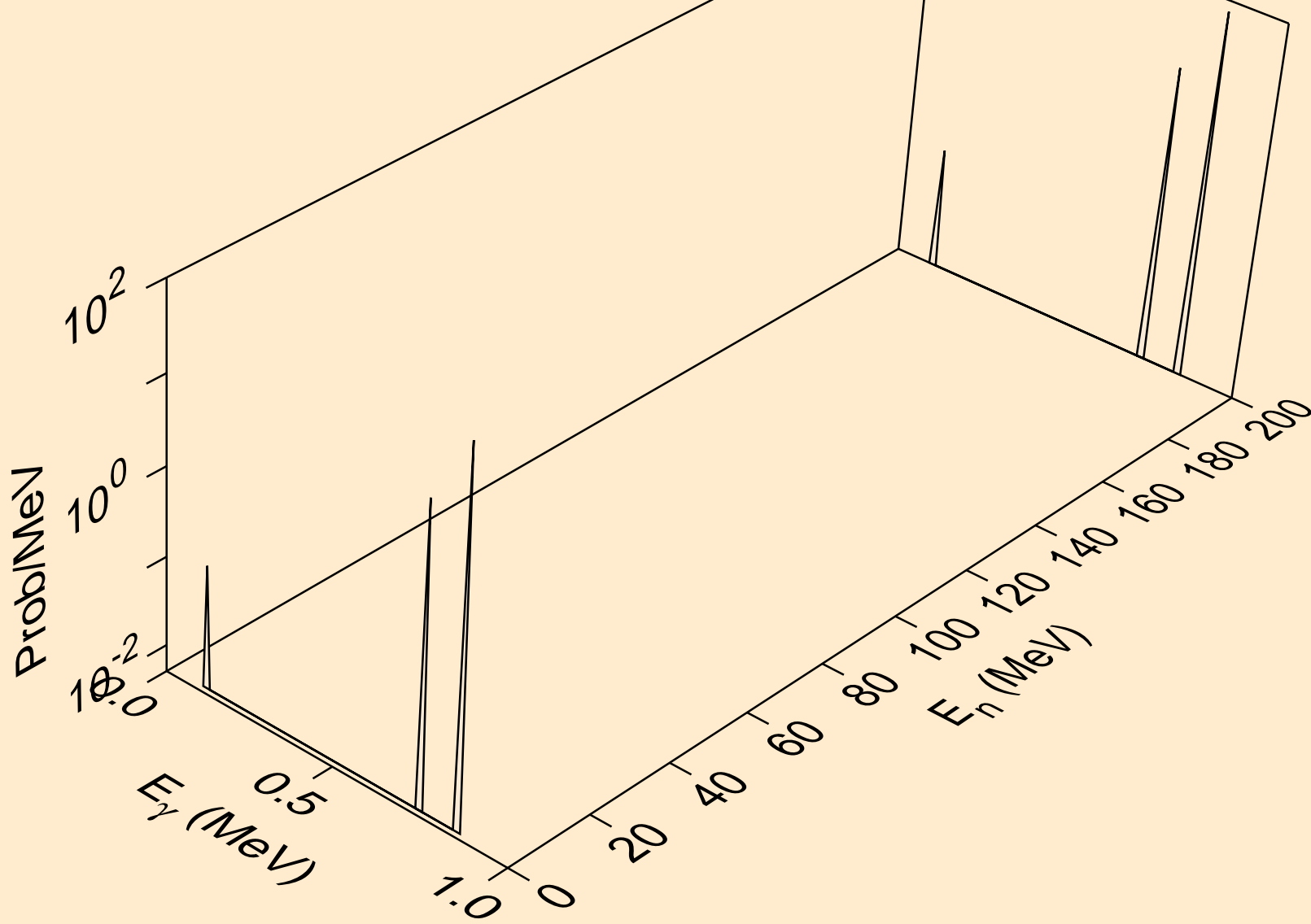

21-SC-45 FOR FENDL-3.1 FROM JEFF-3.1.1 WITH NJOY2012.50+  
Photon emission for (n,a\*8)

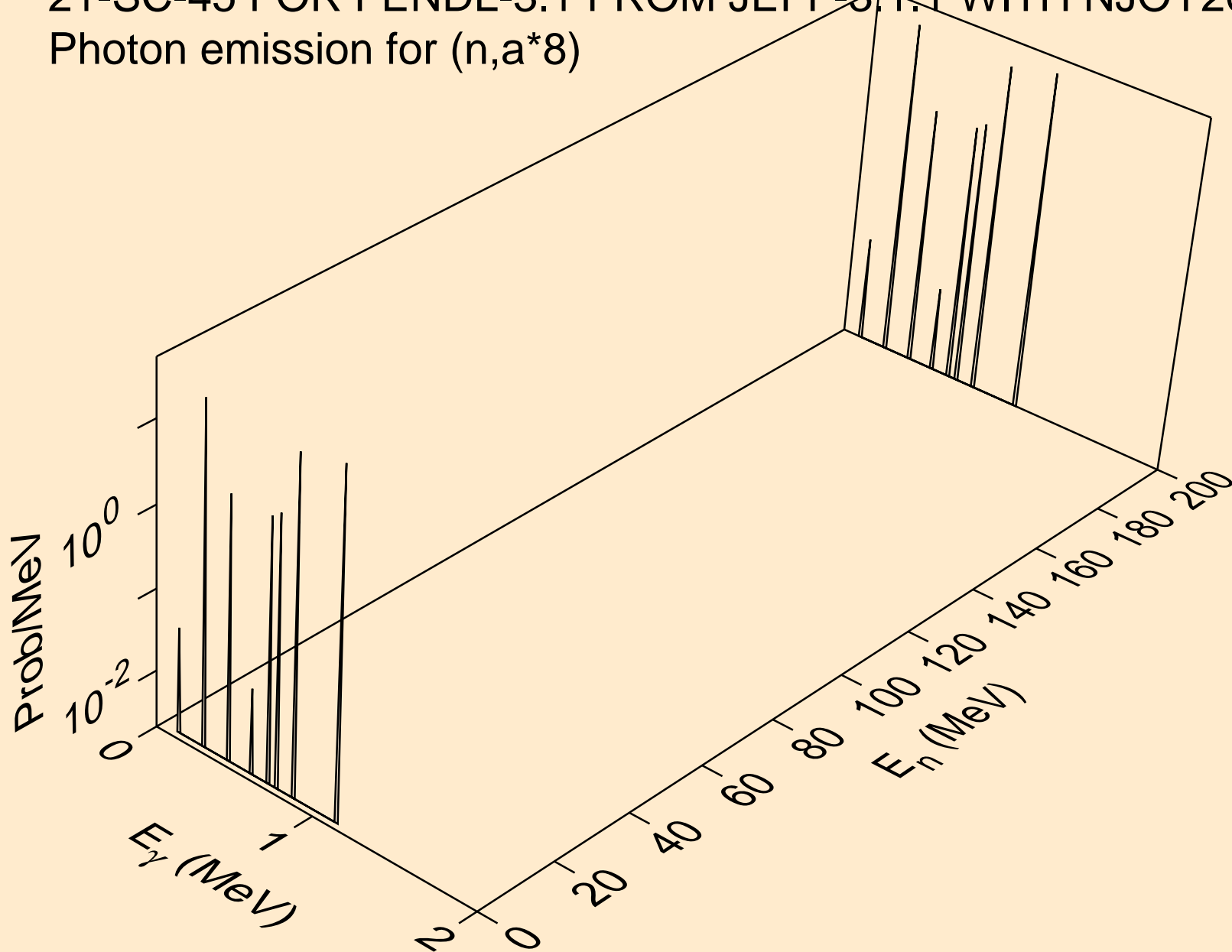



21-SC-45 FOR FENDL-3.1 FROM JEFF-3.1.1 WITH NJOY2012.50+  
Photon emission for (n,a\*9)

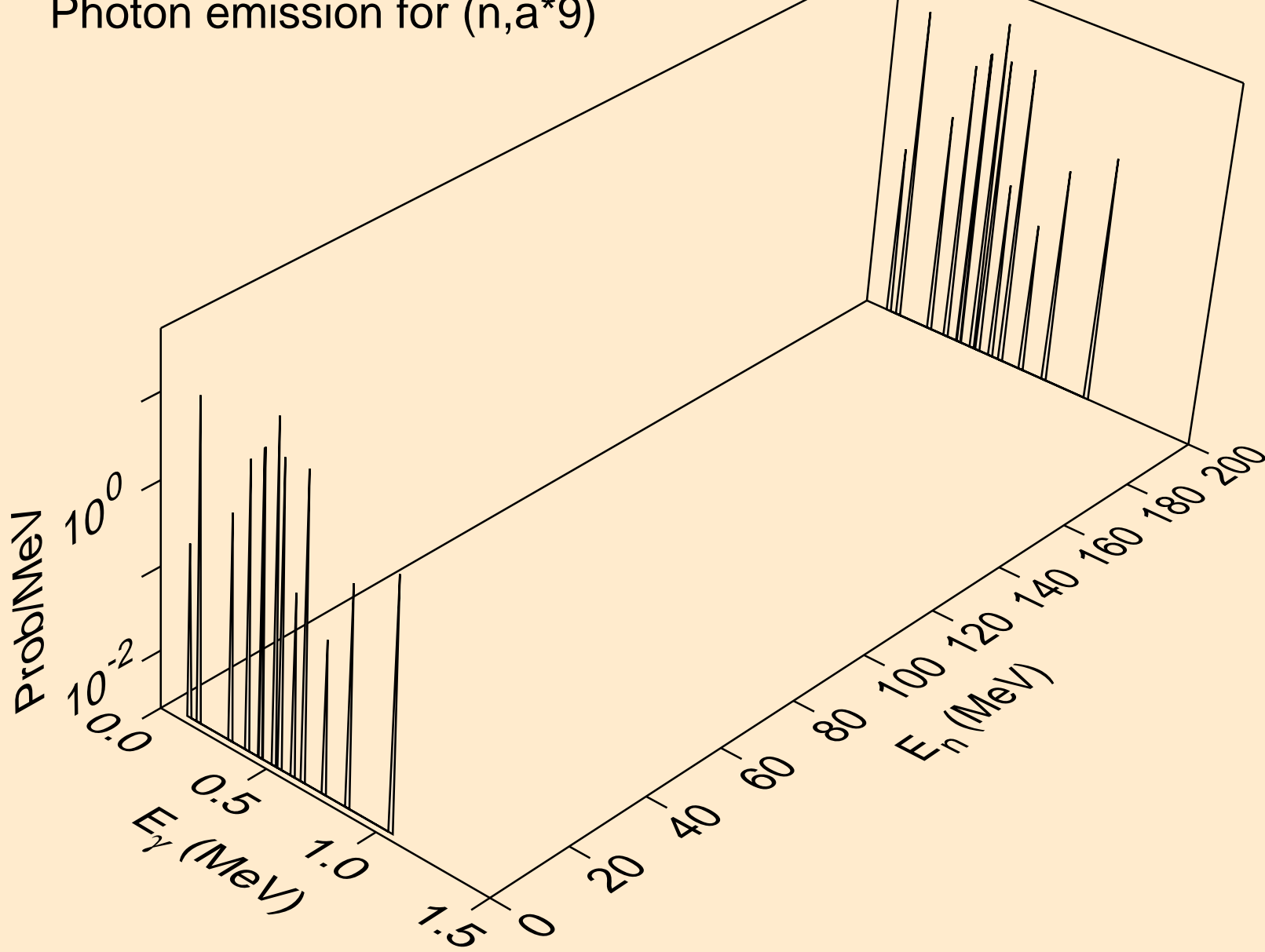

21-SC-45 FOR FENDL-3.1 FROM JEFF-3.1.1 WITH NJOY2012.50+  
Photon emission for (n,a\*10)

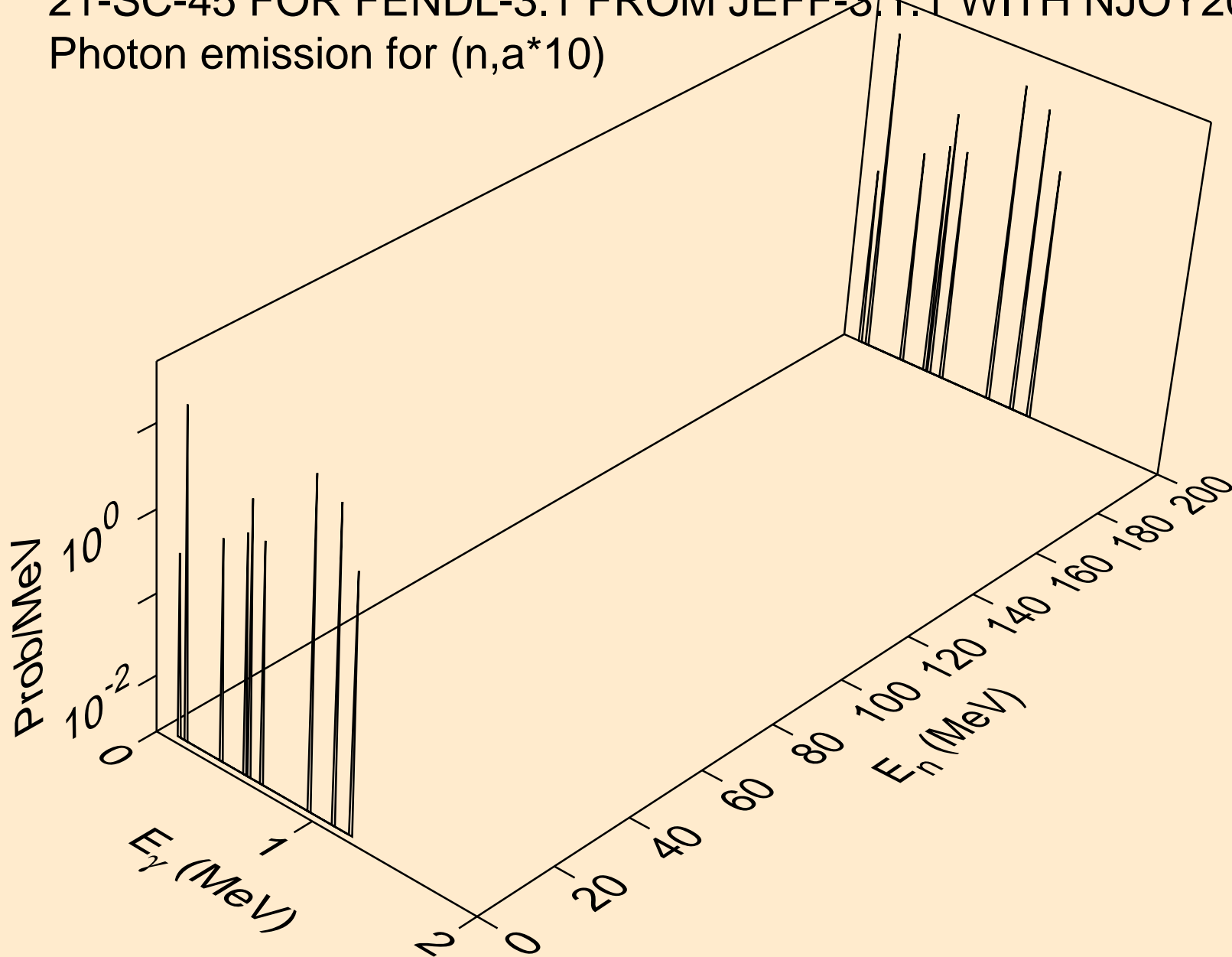

21-SC-45 FOR FENDL-3.1 FROM JEFF-3.1.1 WITH NJOY2012.50+  
Photon emission for (n,a\*c)

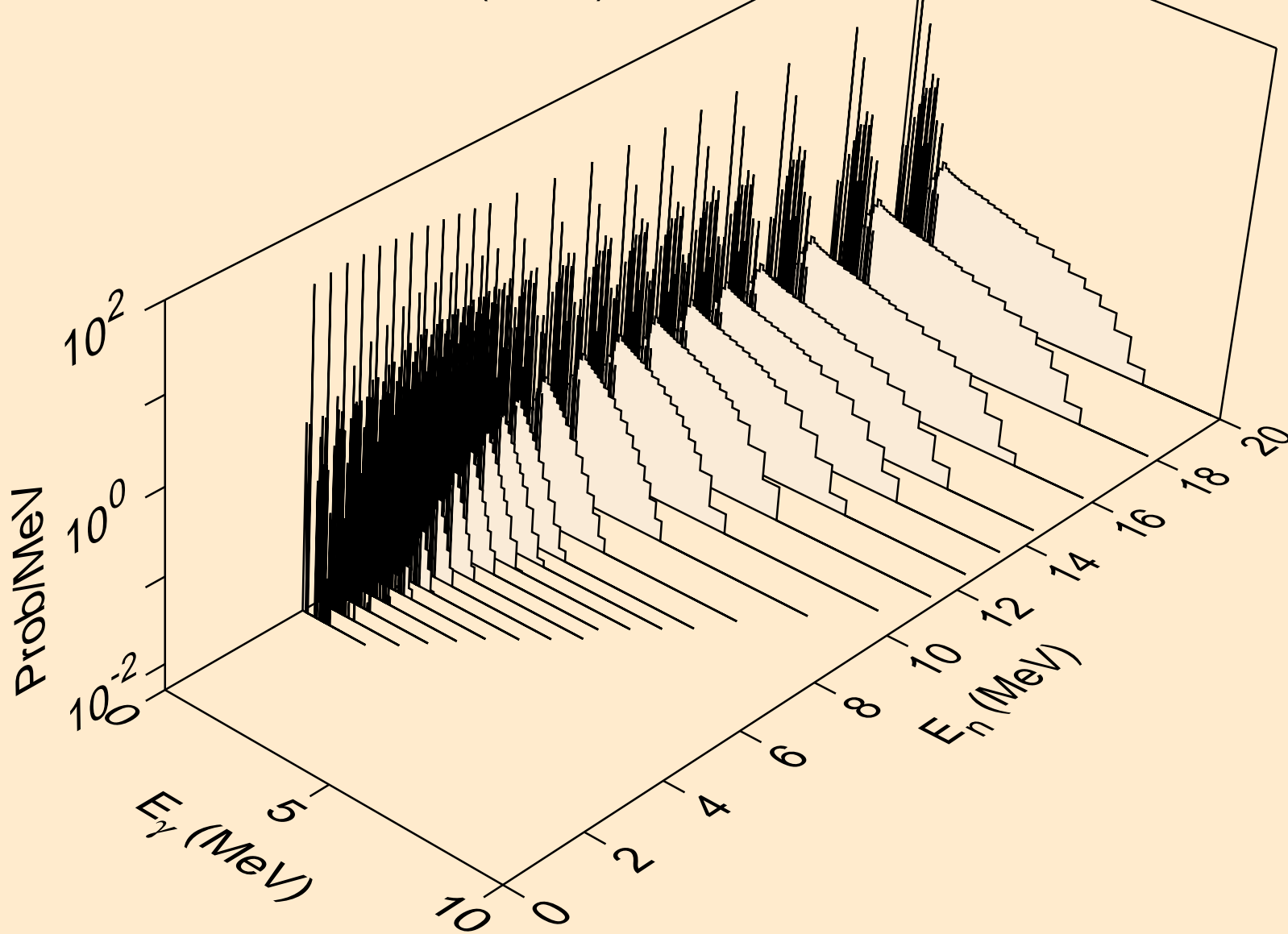

21-SC-45 FOR FENDL-3.1 FROM JEFF-3.1.1 WITH NJOY2012.50+  
thermal capture photon spectrum

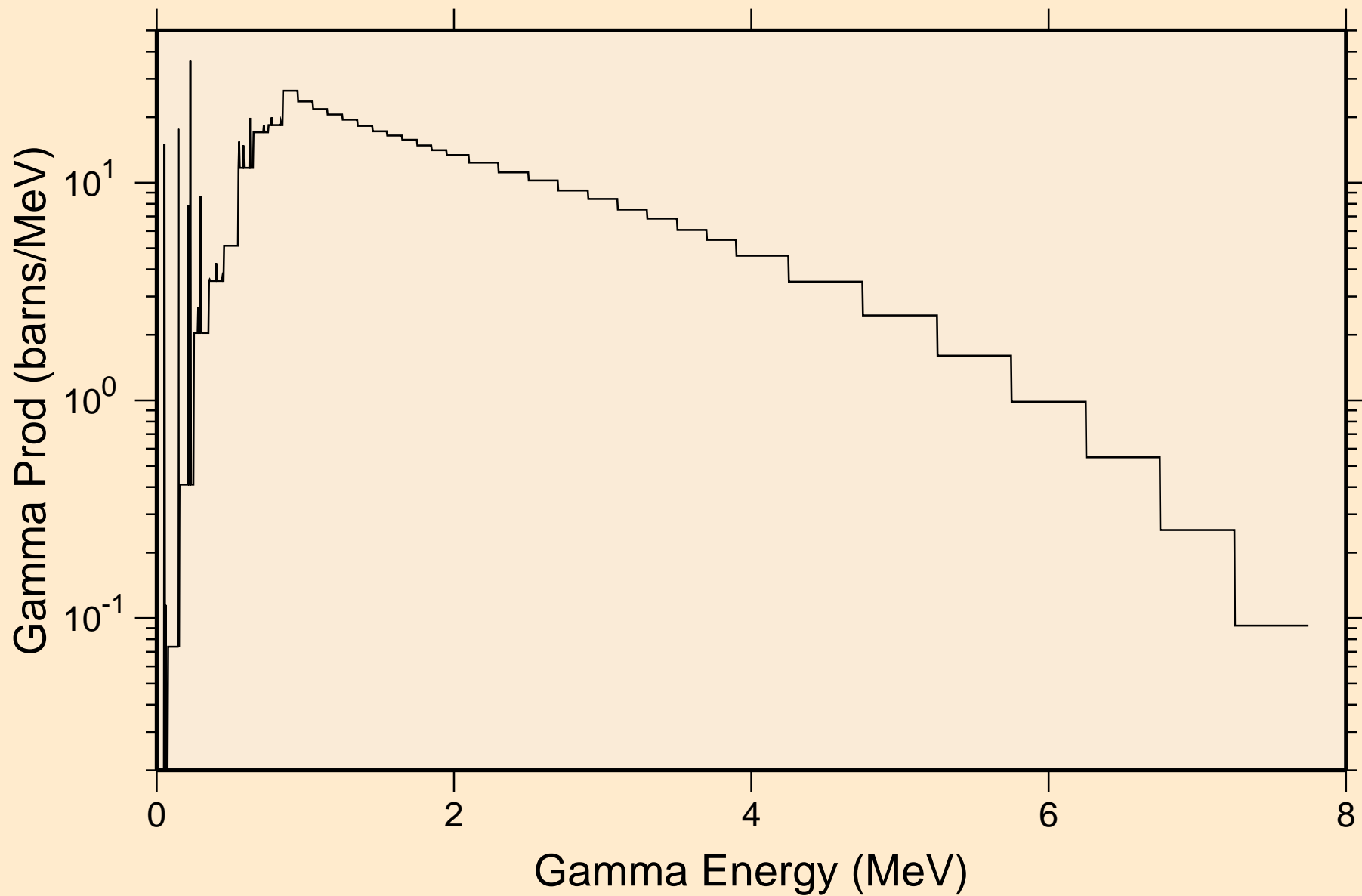

21-SC-45 FOR FENDL-3.1 FROM JEFF-3.1.1 WITH NJOY2012.50+  
14 MeV photon spectrum

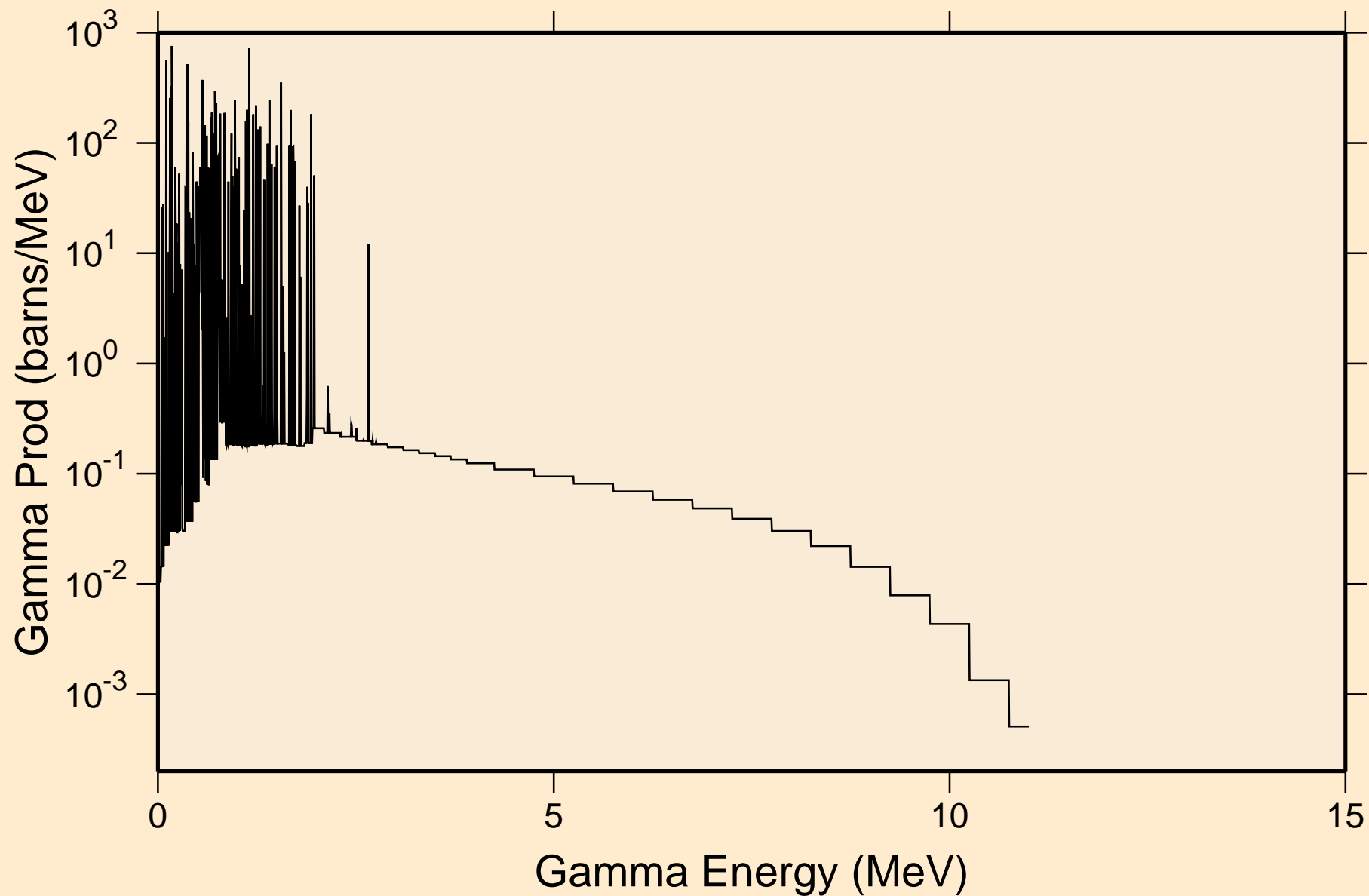

# 21-SC-45 FOR FENDL-3.1 FROM JEFF-3.1.1 WITH NJOY2012.50+

## Particle heating contributions

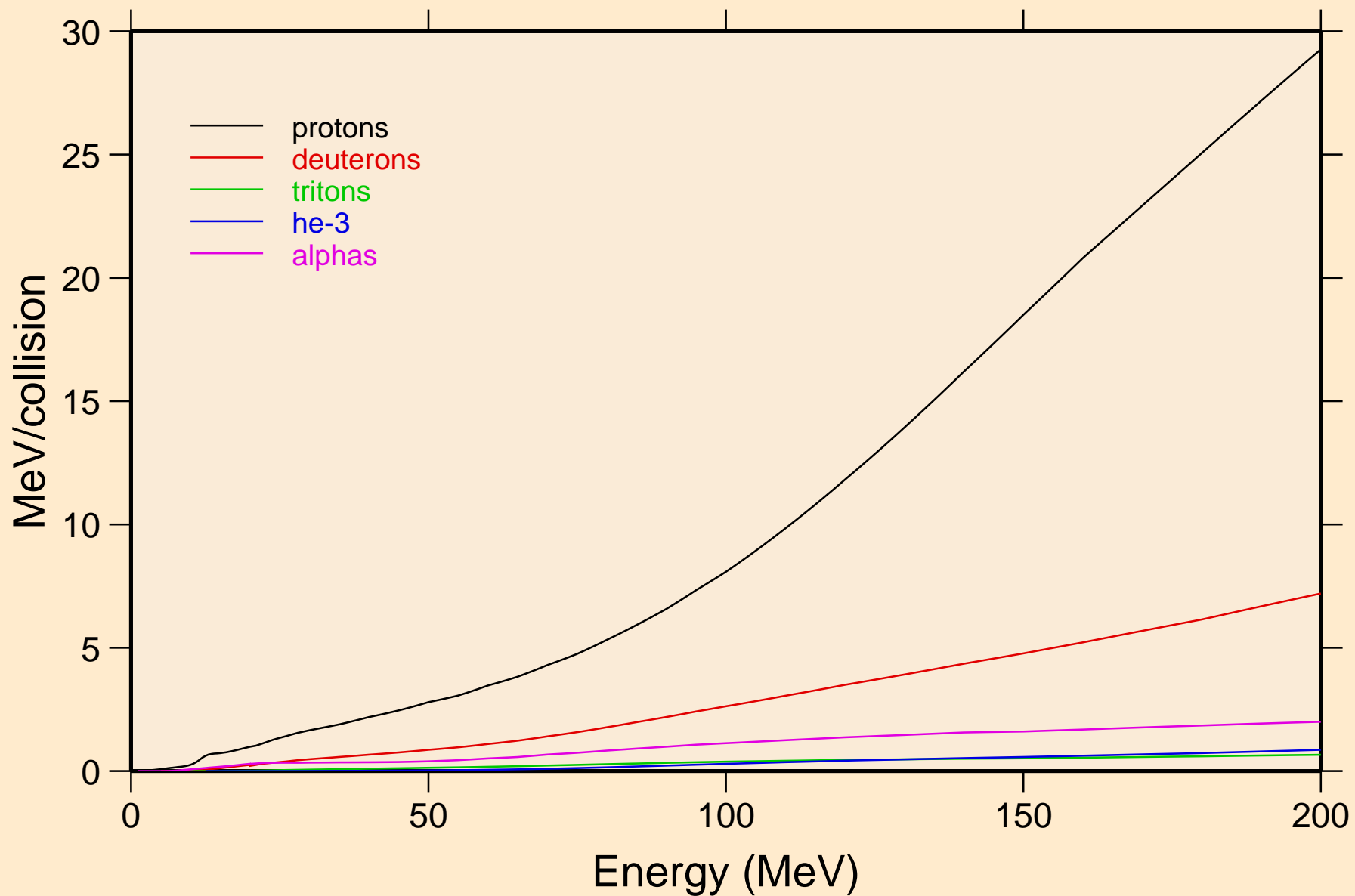

# 21-SC-45 FOR FENDL-3.1 FROM JEFF-3.1.1 WITH NJOY2012.50+ Recoil Heating

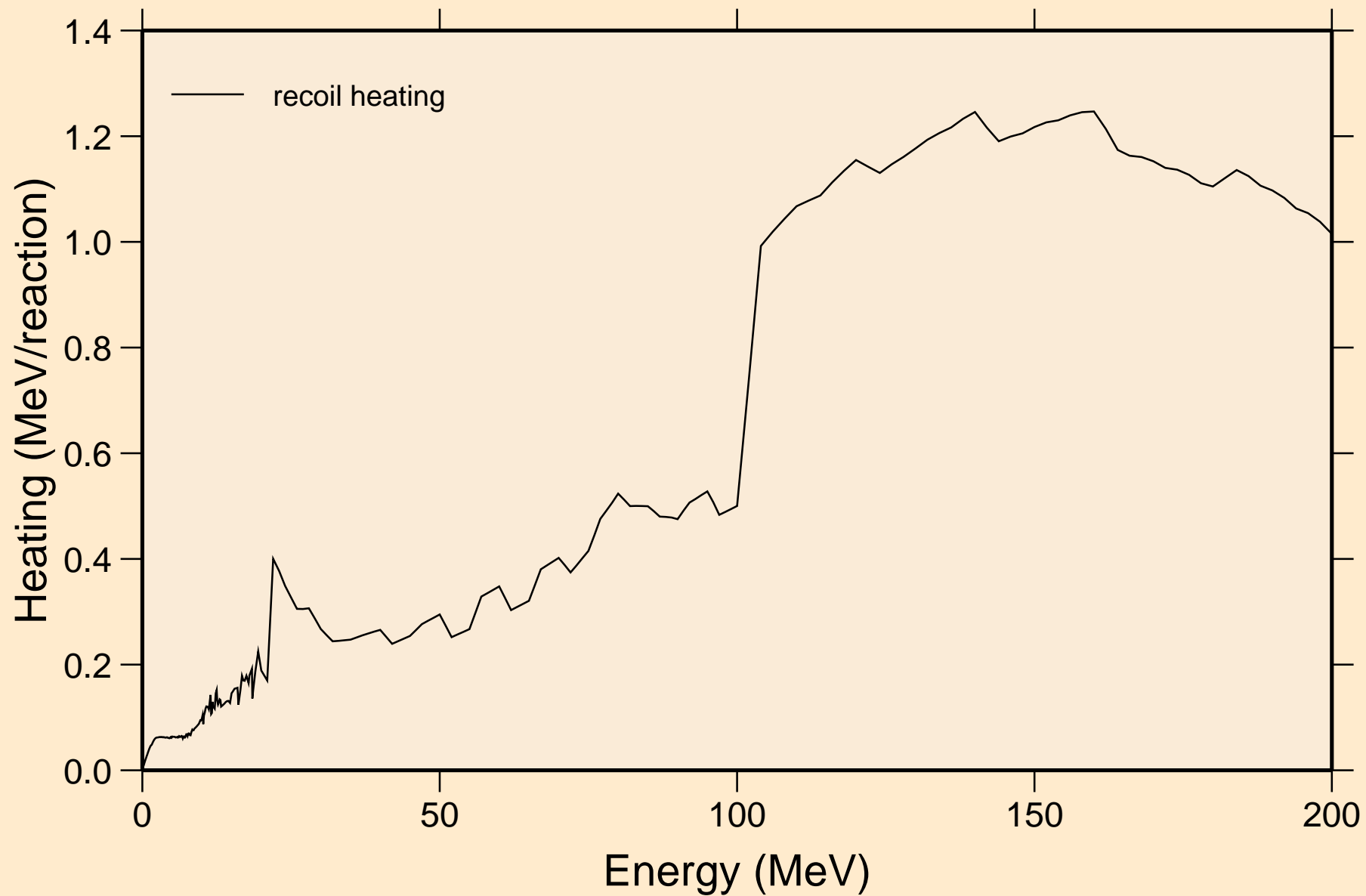

# 21-SC-45 FOR FENDL-3.1 FROM JEFF-3.1.1 WITH NJOY2012.50+

## Particle production cross sections

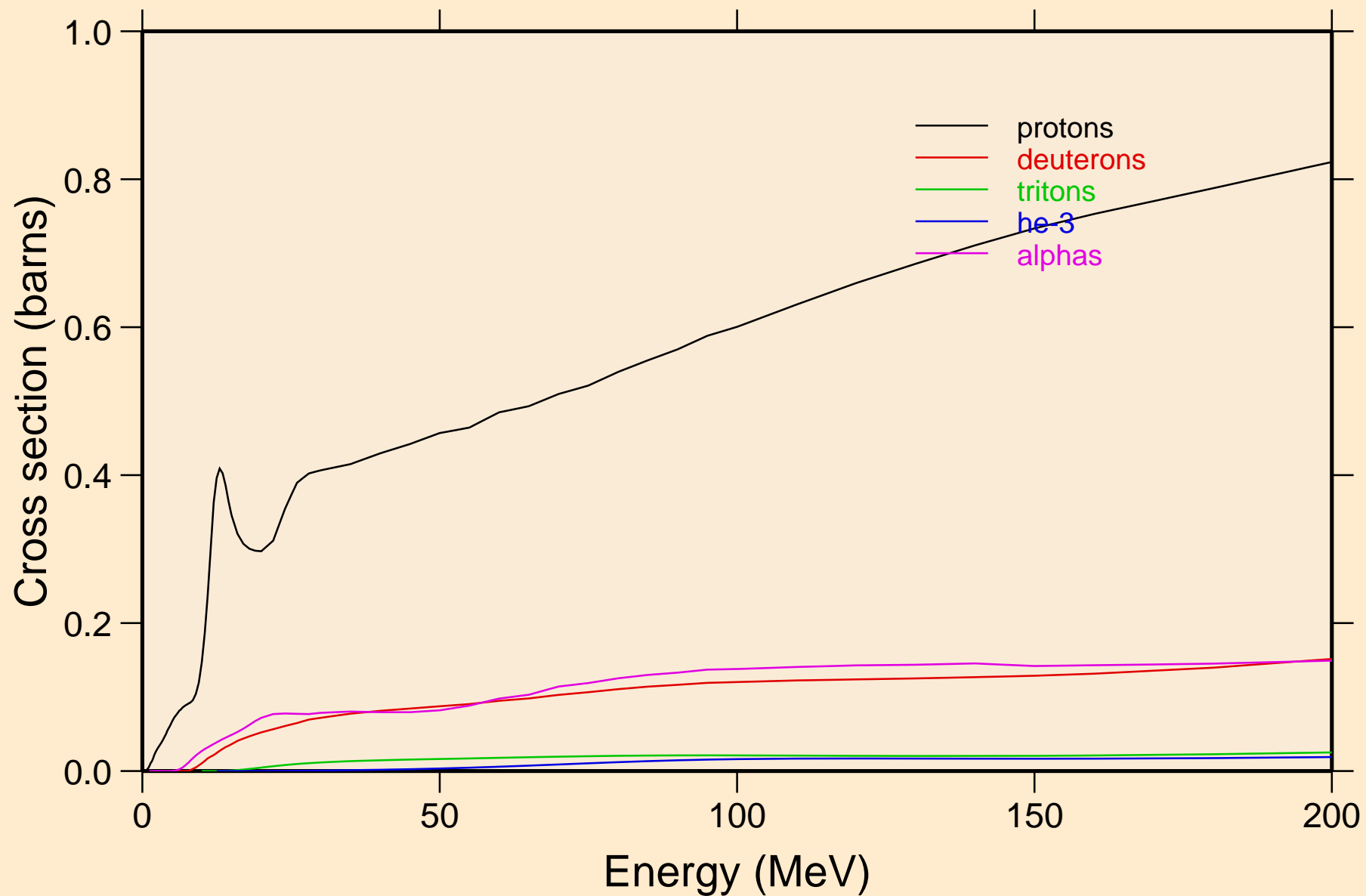



21-SC-45 FOR FENDL-3.1 FROM JEFF-3.1.1 WITH NJOY2012.50+  
protons from (n,x)

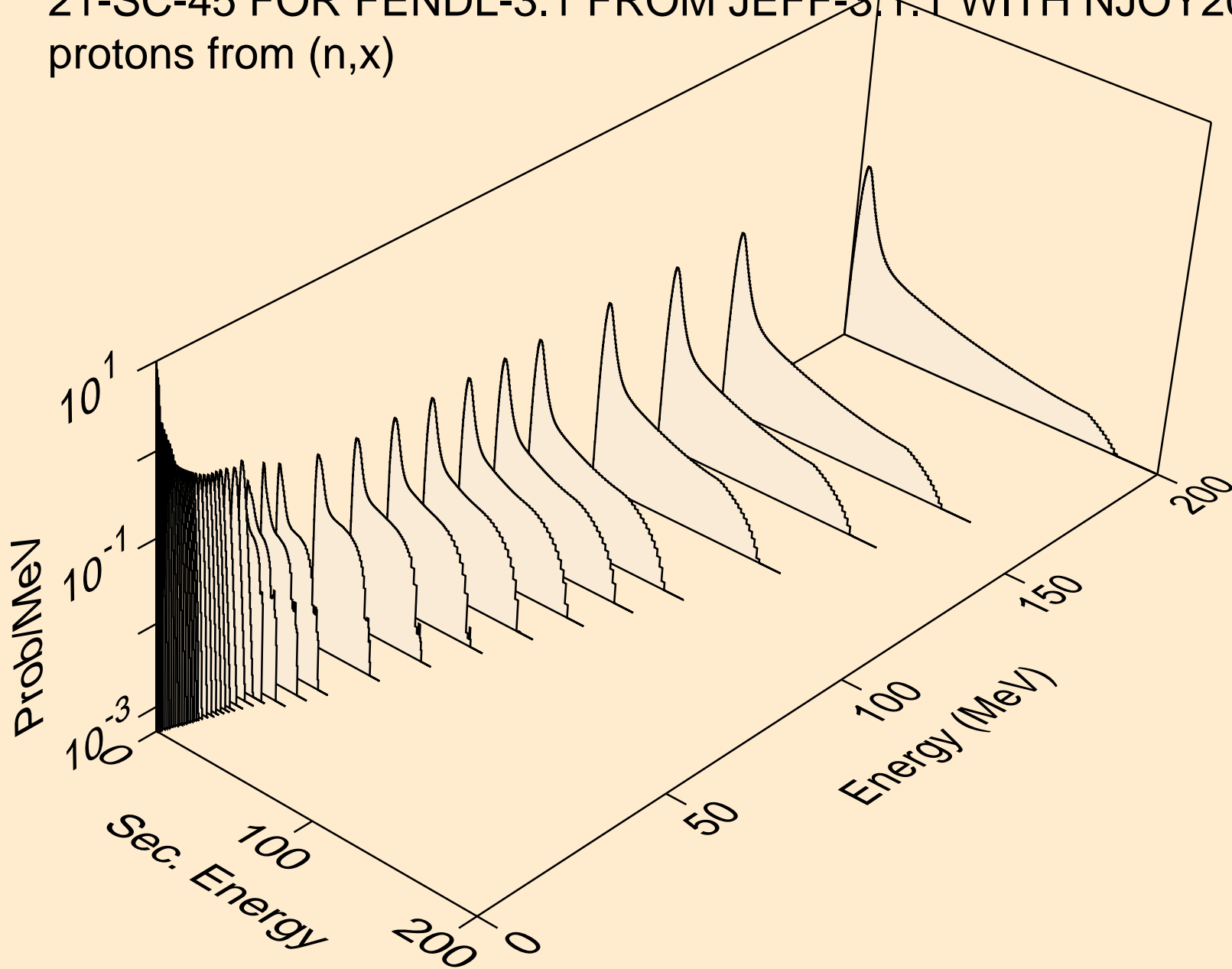

21-SC-45 FOR FENDL-3.1 FROM JEFF-3.1.1 WITH NJOY2012.50+  
protons from (n,n\*)p

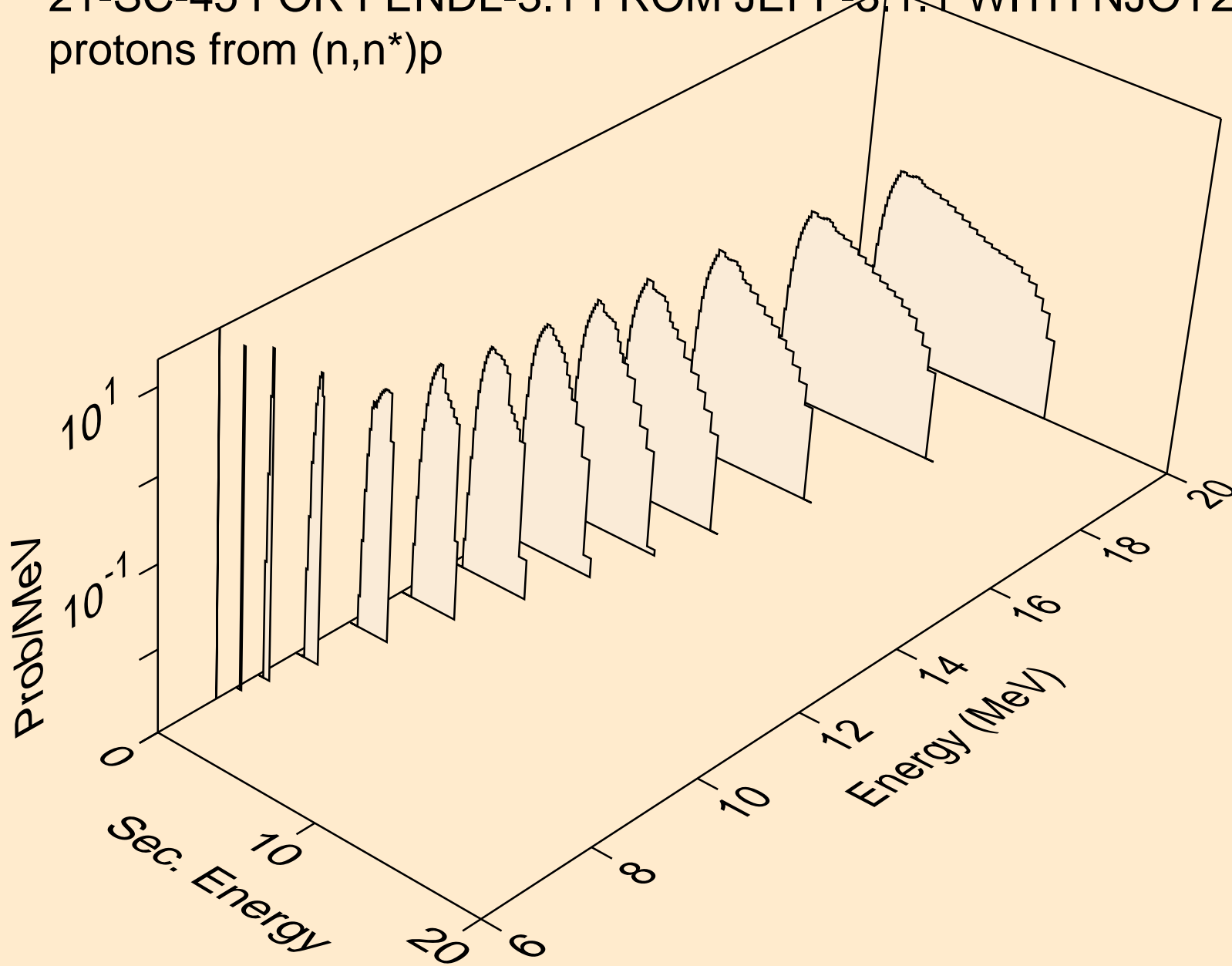

21-SC-45 FOR FENDL-3.1 FROM JEFF-3.1.1 WITH NJOY2012.50+  
protons from (n,2np)

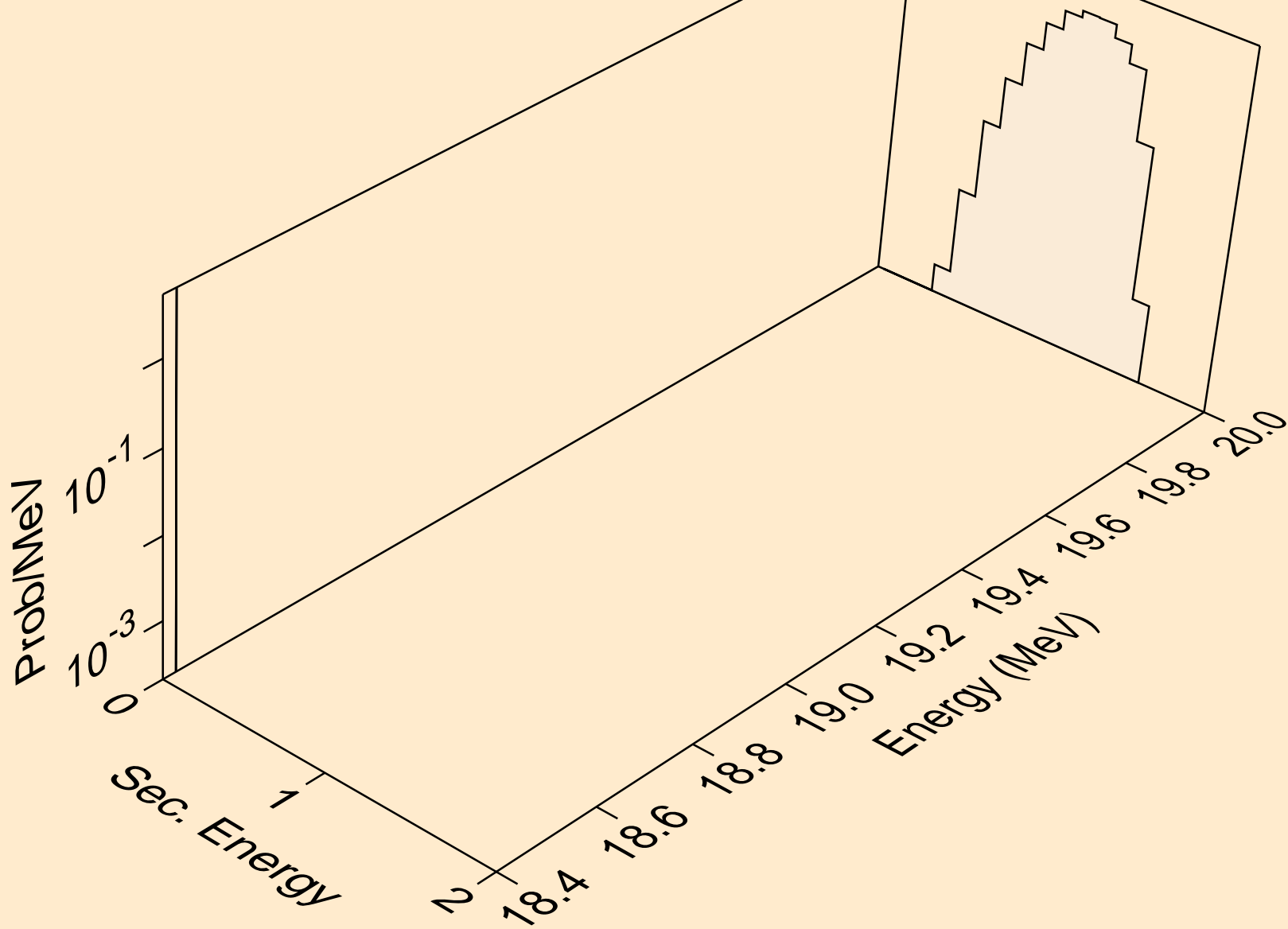

21-SC-45 FOR FENDL-3.1 FROM JEFF-3.1.1 WITH NJOY2012.50+  
protons from (n,2p)

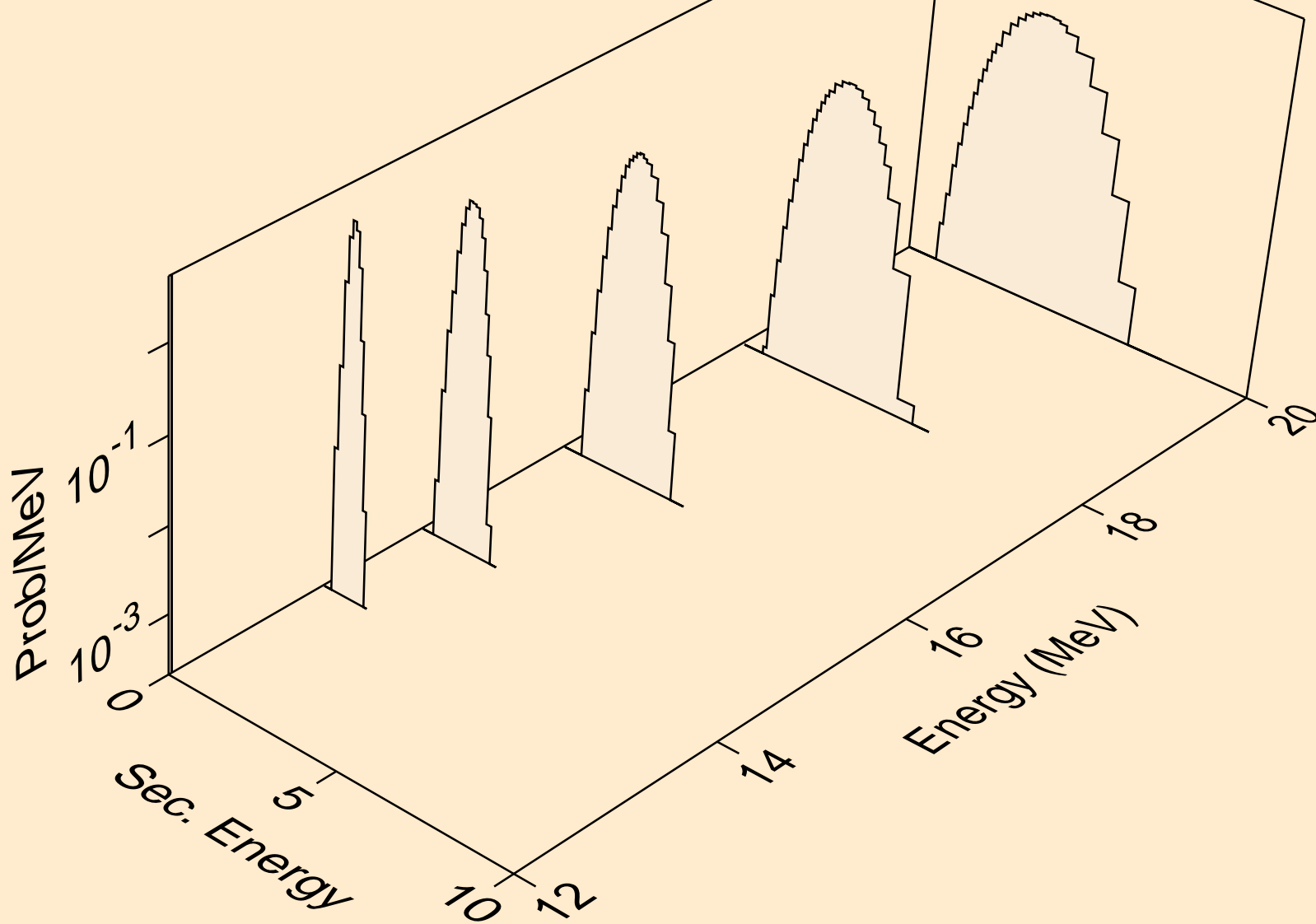

21-SC-45 FOR FENDL-3.1 FROM JEFF-3.1.1 WITH NJOY2012.50+  
protons from (n,pa)

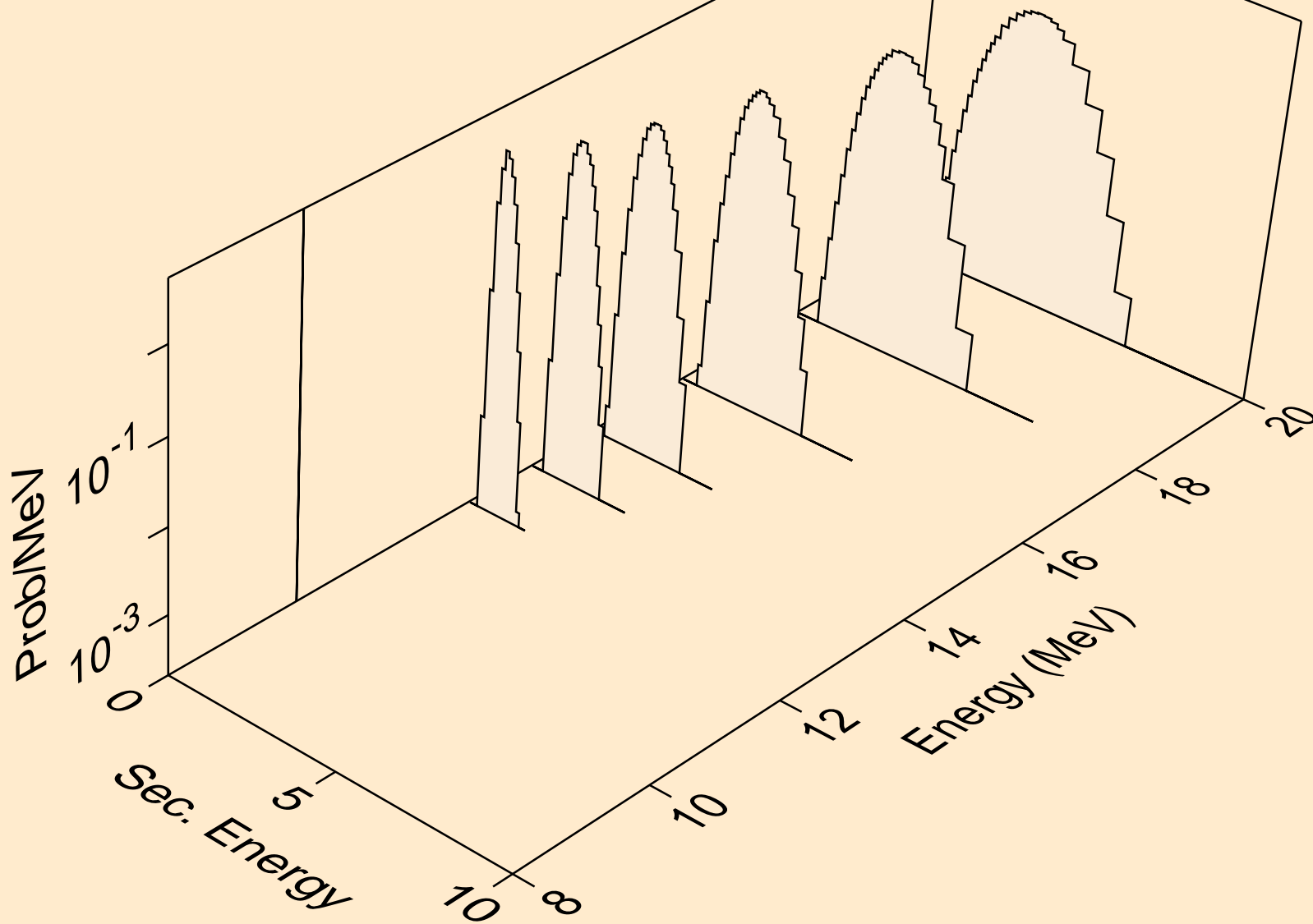

21-SC-45 FOR FENDL-3.1 FROM JEFF-3.1.1 WITH NJOY2012.50+  
angular distribution for (n,p\*0) proton

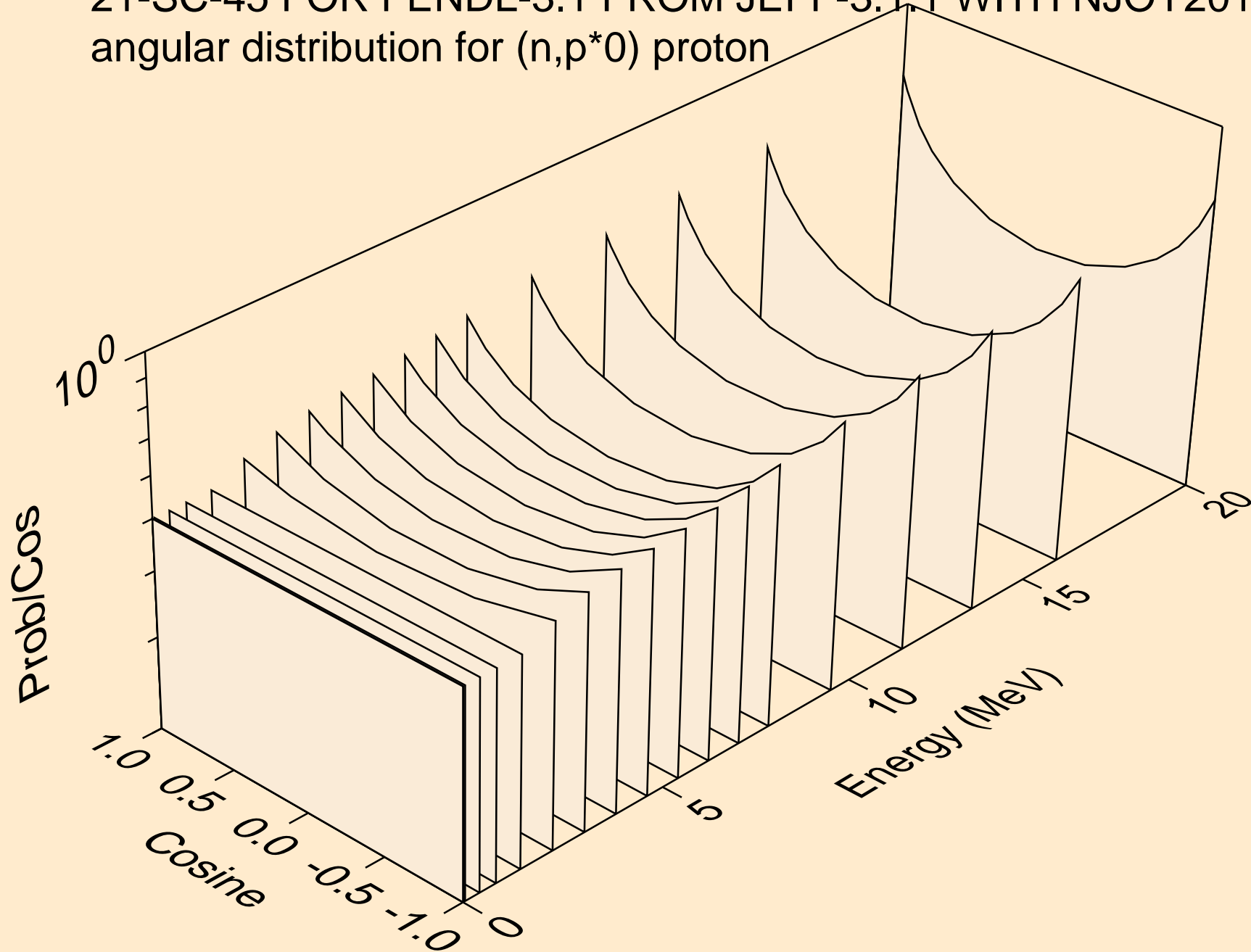

21-SC-45 FOR FENDL-3.1 FROM JEFF-3.1.1 WITH NJOY2012.50+  
angular distribution for (n,p\*1) proton

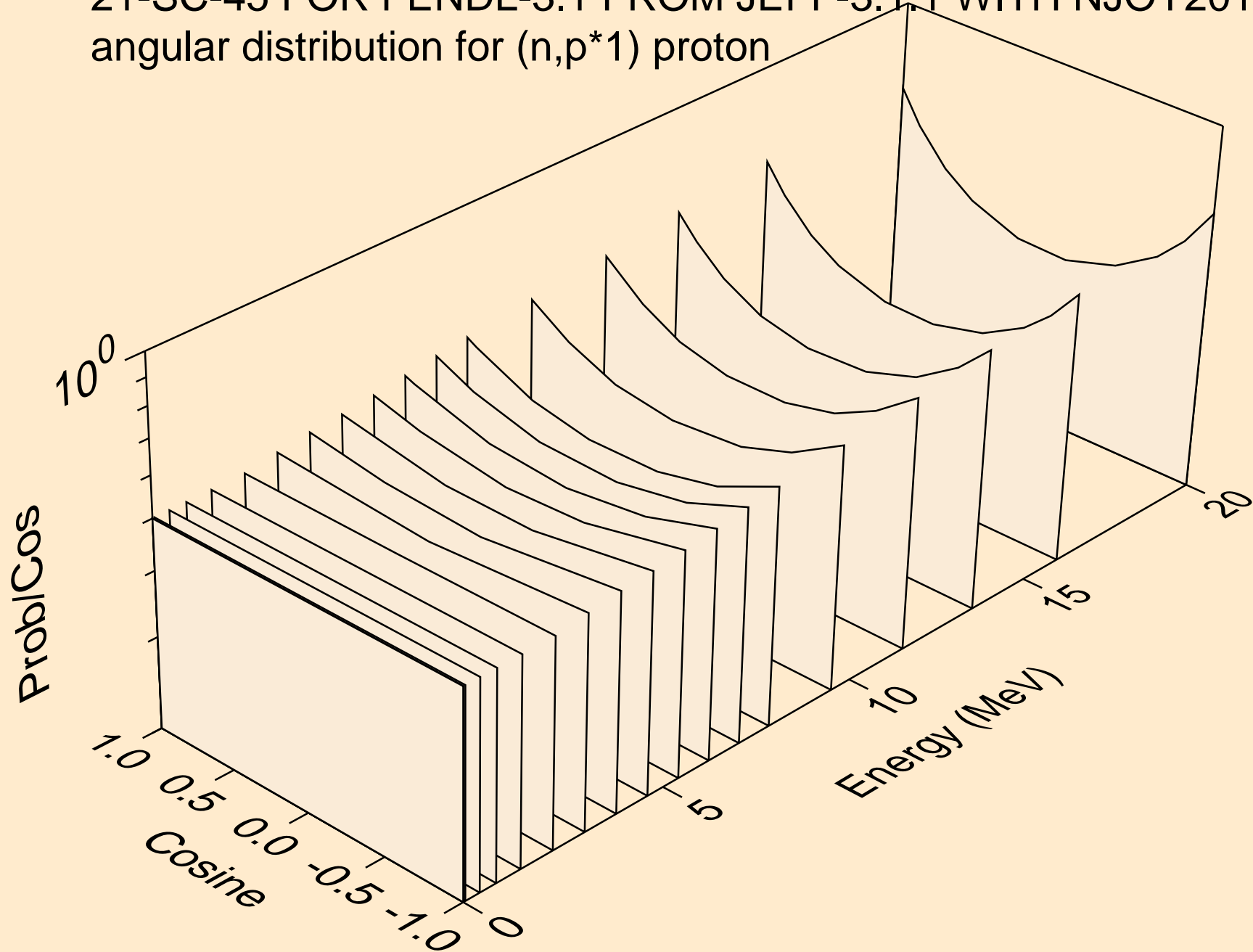

21-SC-45 FOR FENDL-3.1 FROM JEFF-3.1.1 WITH NJOY2012.50+  
angular distribution for (n,p\*2) proton

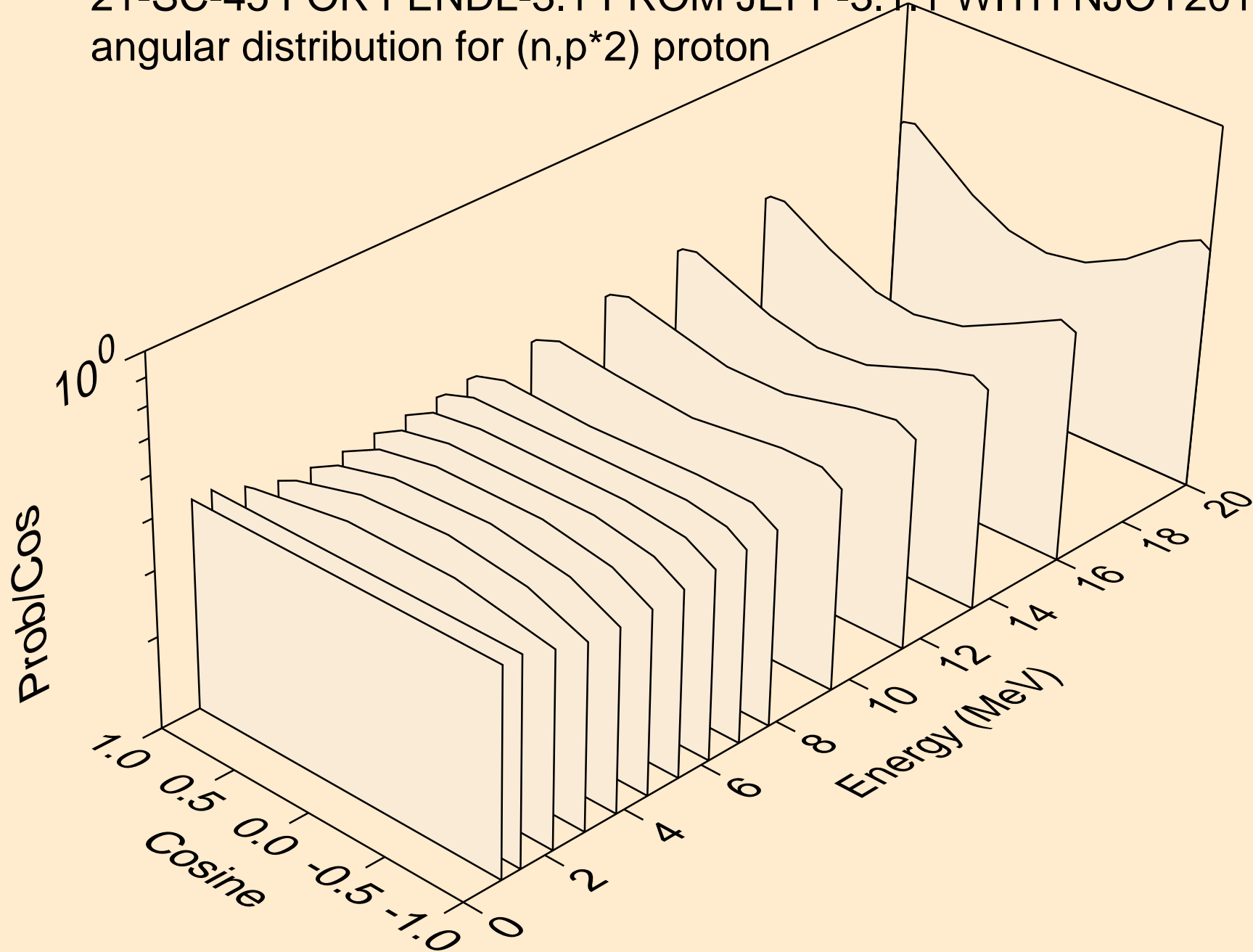



21-SC-45 FOR FENDL-3.1 FROM JEFF-3.1.1 WITH NJOY2012.50+  
angular distribution for (n,p\*3) proton

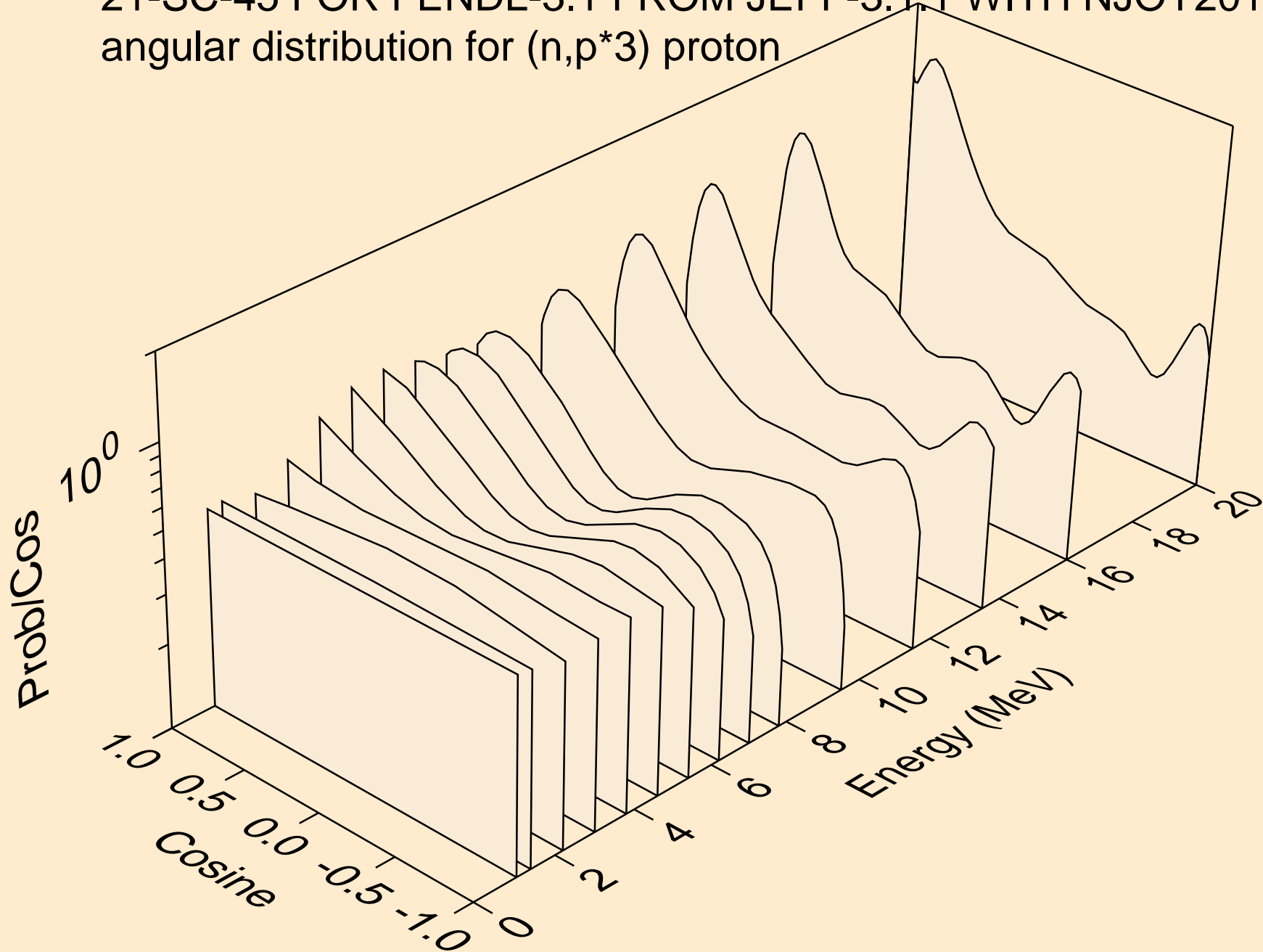

21-SC-45 FOR FENDL-3.1 FROM JEFF-3.1.1 WITH NJOY2012.50+  
angular distribution for (n,p\*4) proton

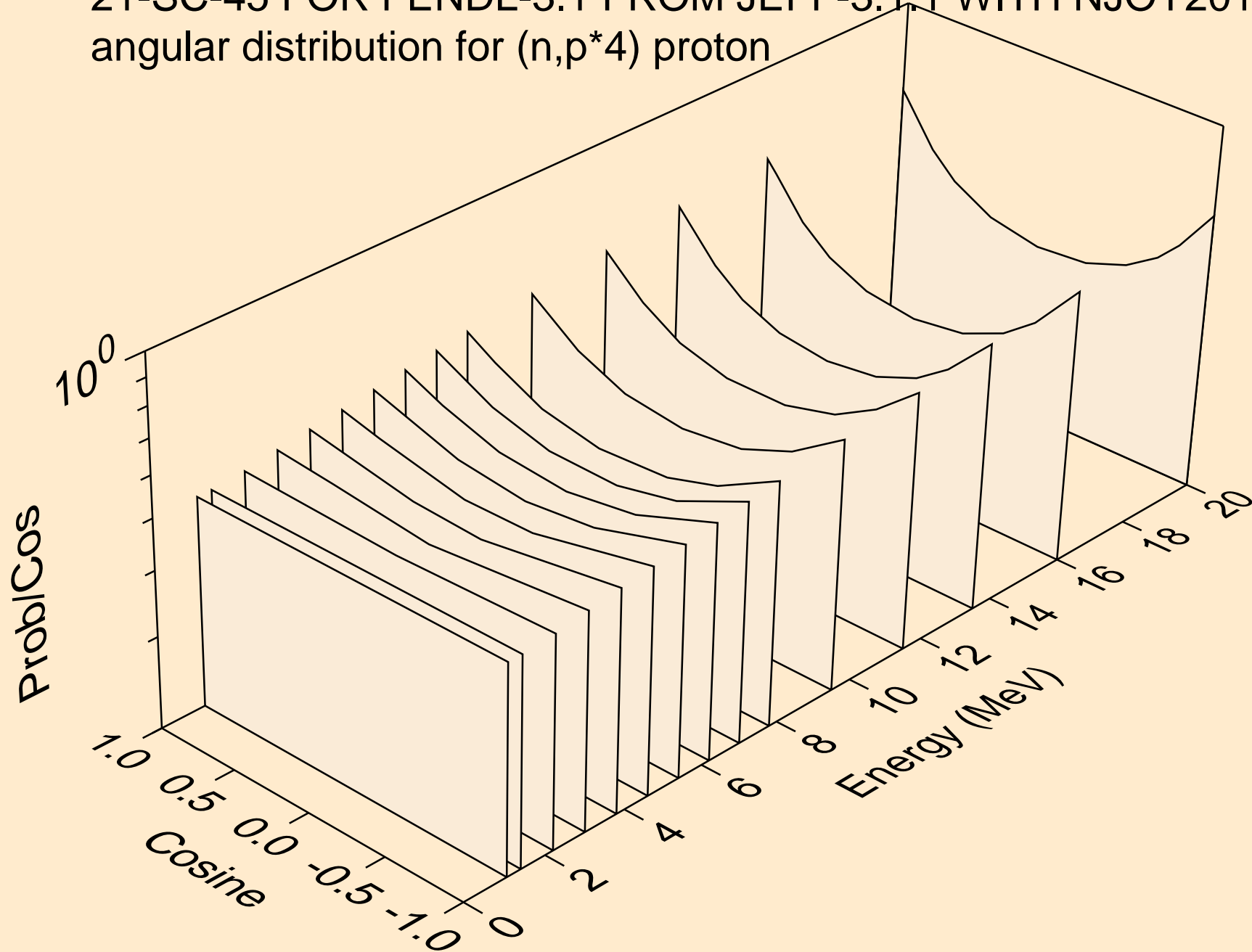

21-SC-45 FOR FENDL-3.1 FROM JEFF-3.1.1 WITH NJOY2012.50+  
angular distribution for (n,p\*5) proton

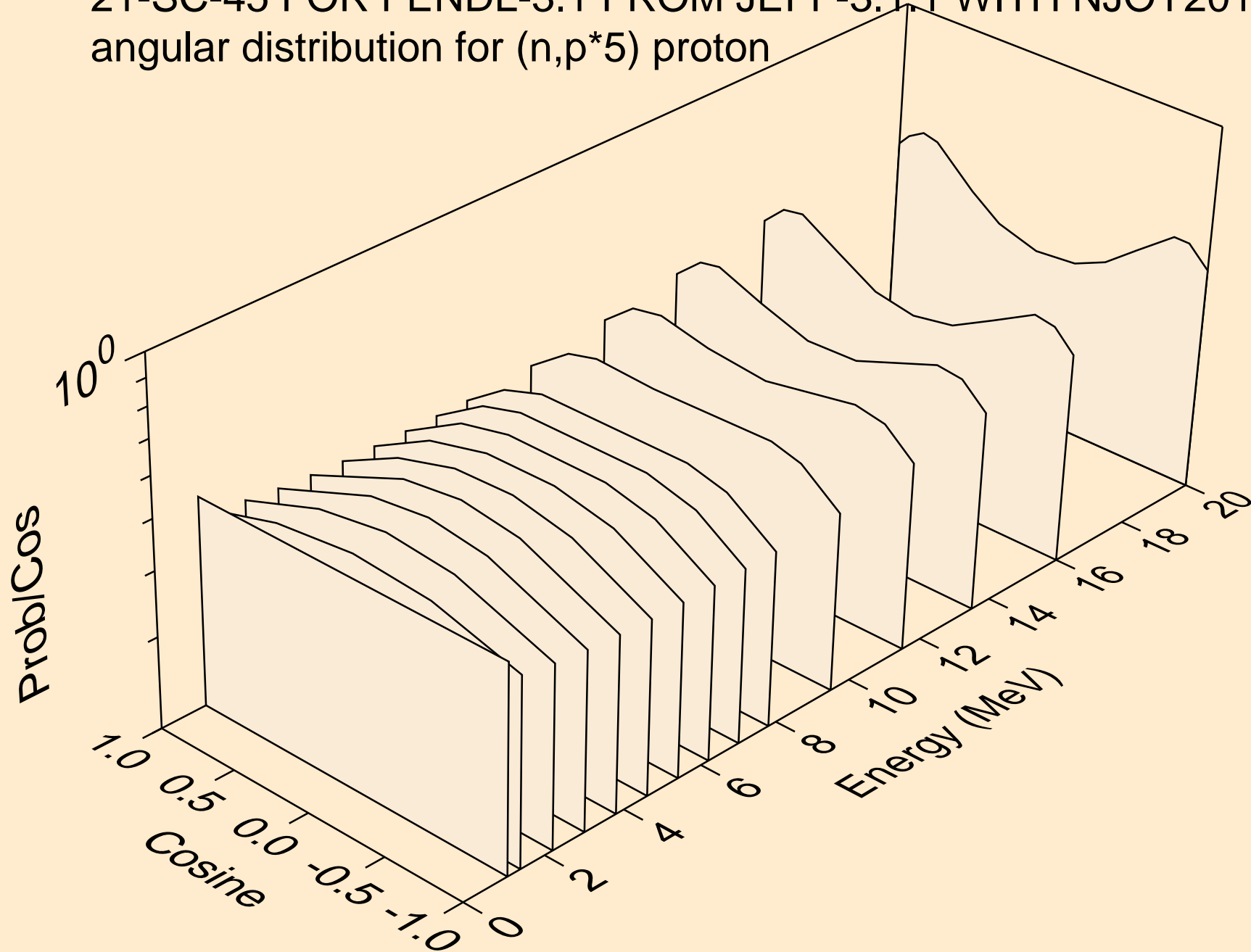

21-SC-45 FOR FENDL-3.1 FROM JEFF-3.1.1 WITH NJOY2012.50+  
angular distribution for (n,p\*6) proton

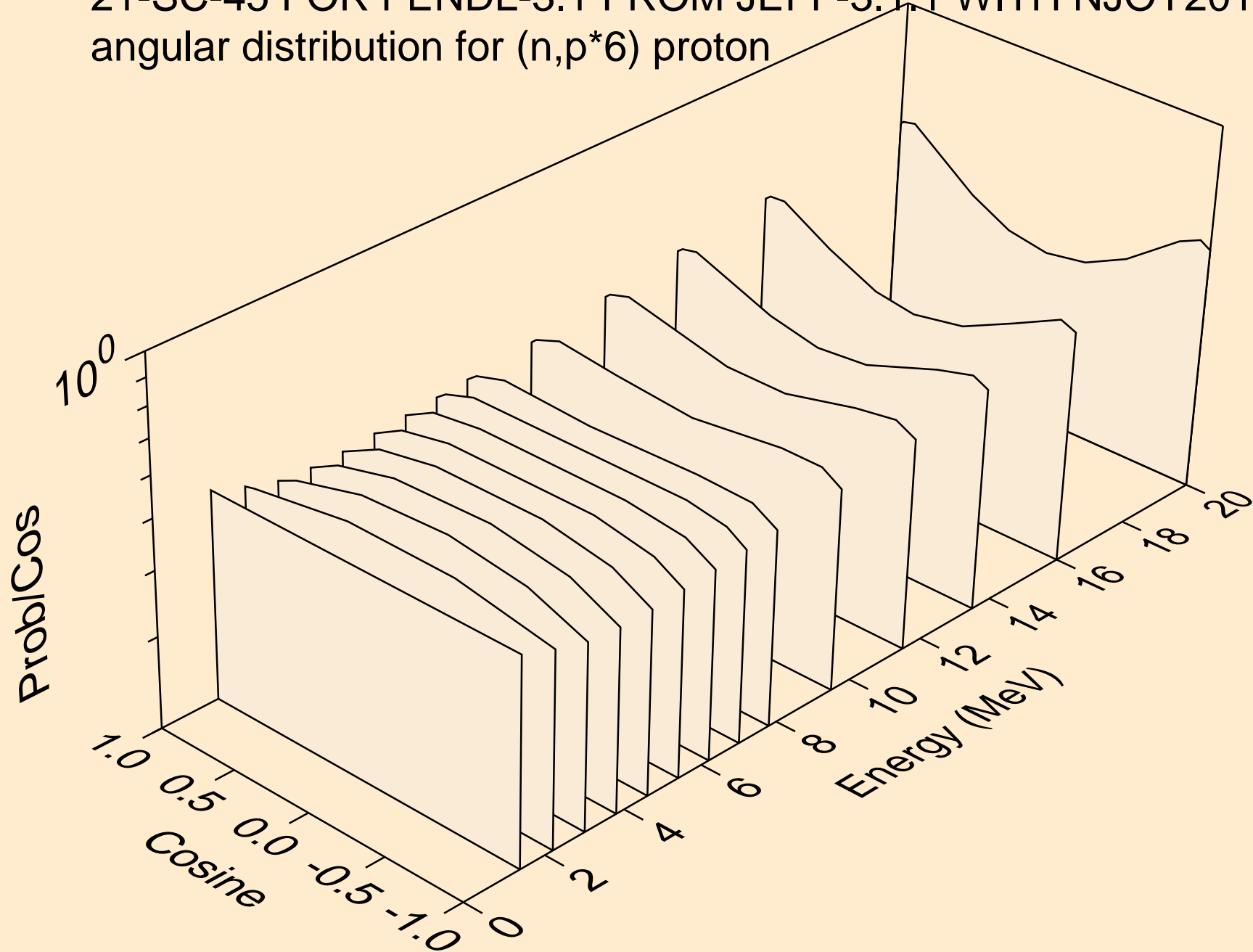

21-SC-45 FOR FENDL-3.1 FROM JEFF-3.1.1 WITH NJOY2012.50+  
angular distribution for (n,p\*7) proton

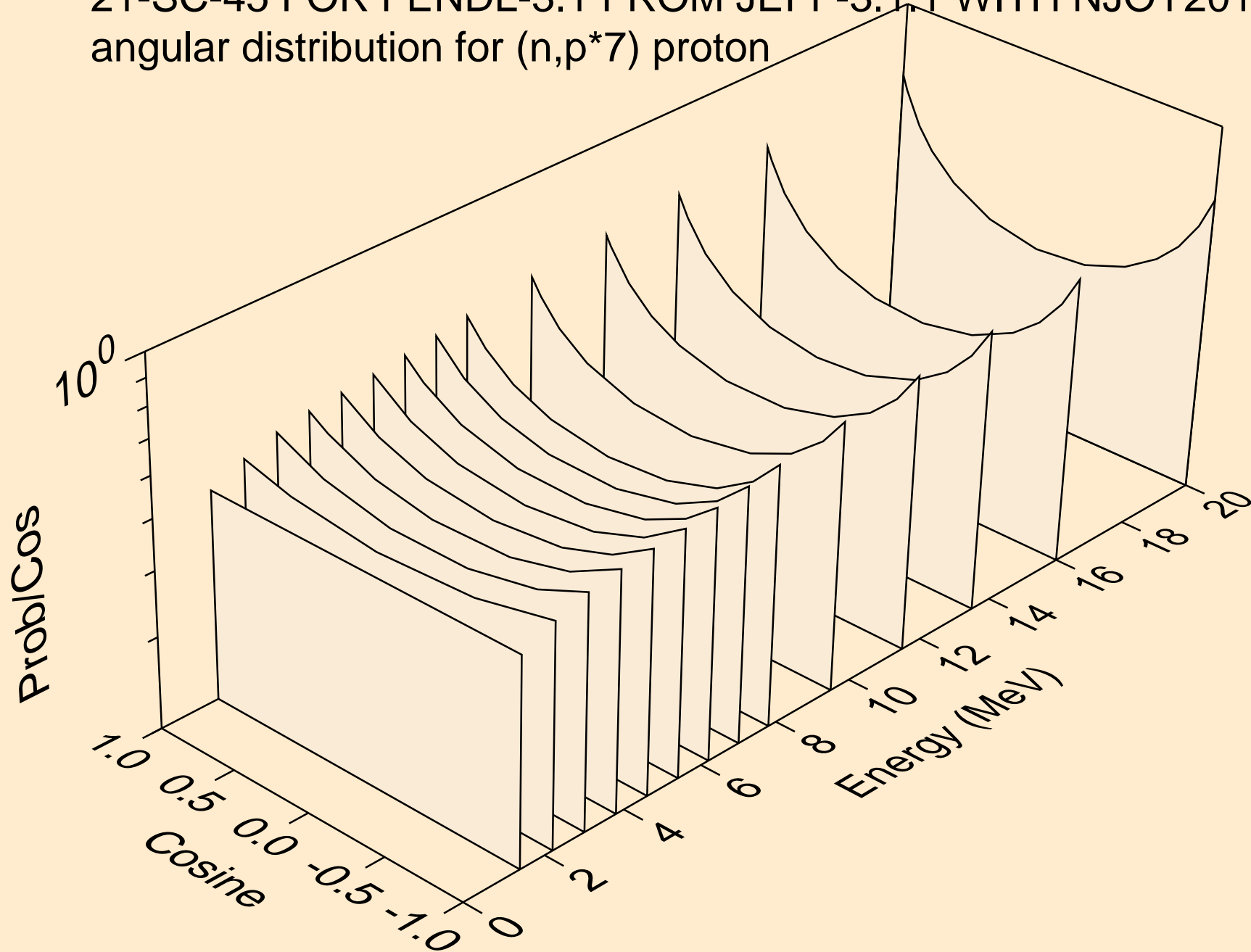

21-SC-45 FOR FENDL-3.1 FROM JEFF-3.1.1 WITH NJOY2012.50+  
angular distribution for (n,p\*8) proton

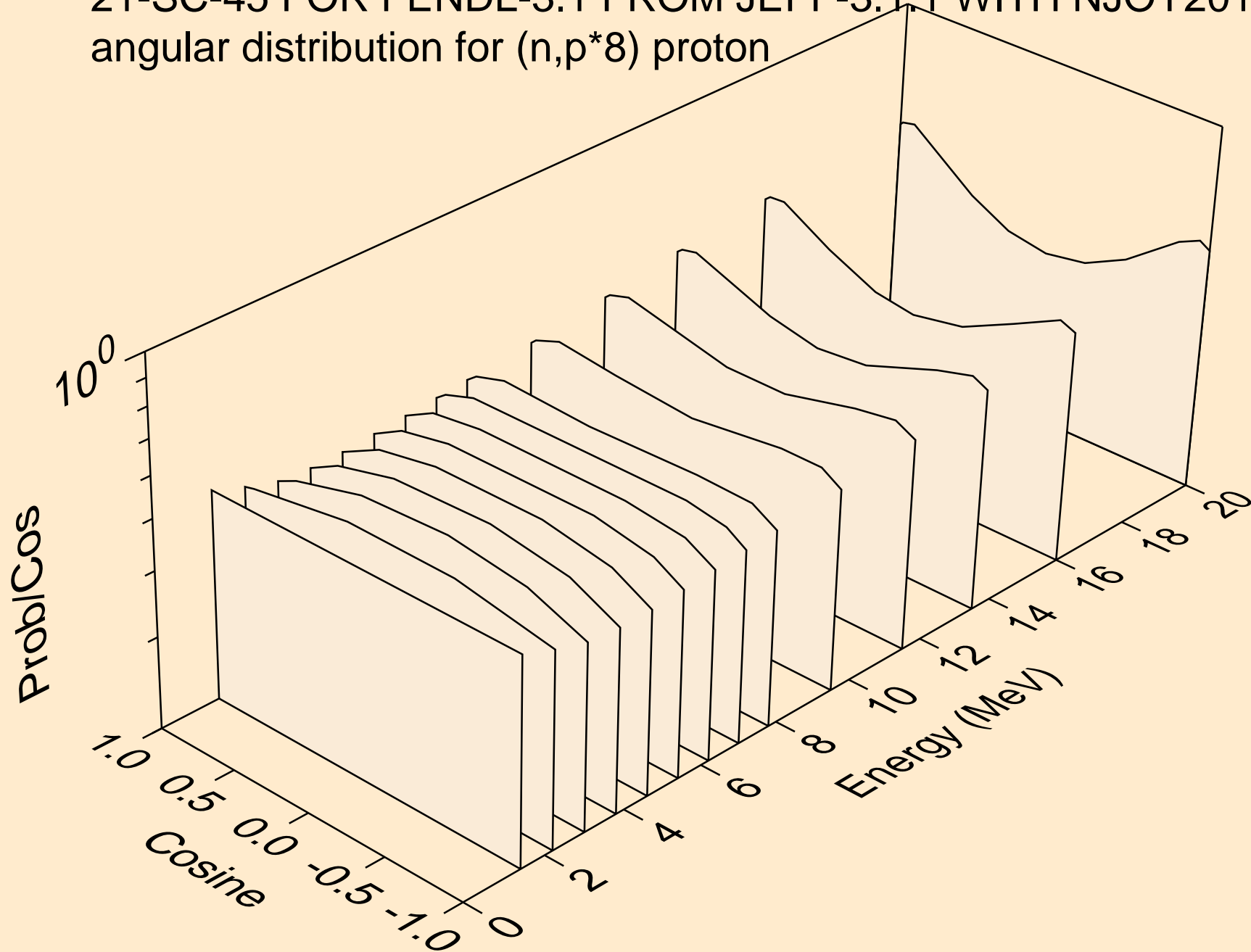

21-SC-45 FOR FENDL-3.1 FROM JEFF-3.1.1 WITH NJOY2012.50+  
angular distribution for (n,p\*9) proton

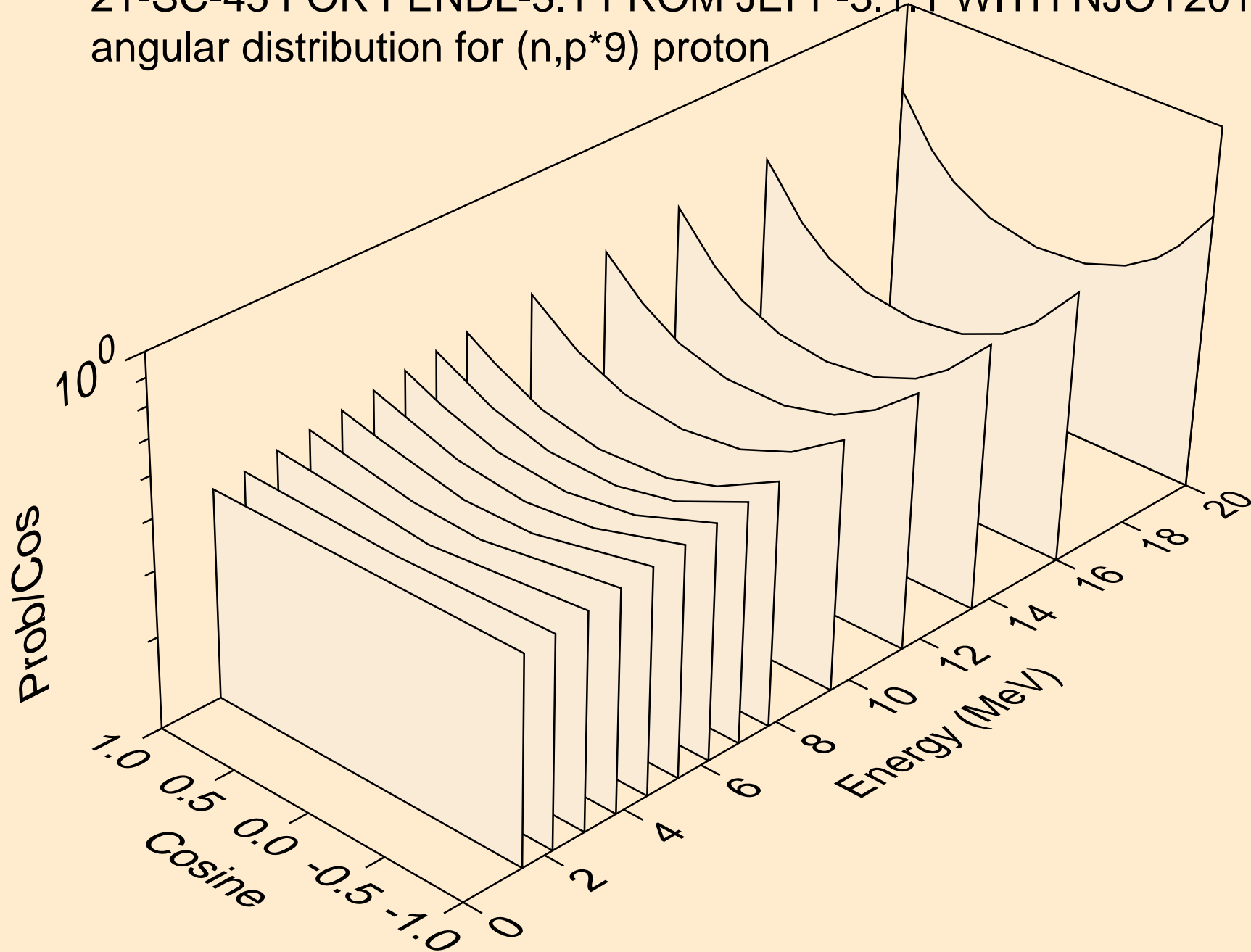

21-SC-45 FOR FENDL-3.1 FROM JEFF-3.1.1 WITH NJOY2012.50+  
angular distribution for (n,p\*10) proton

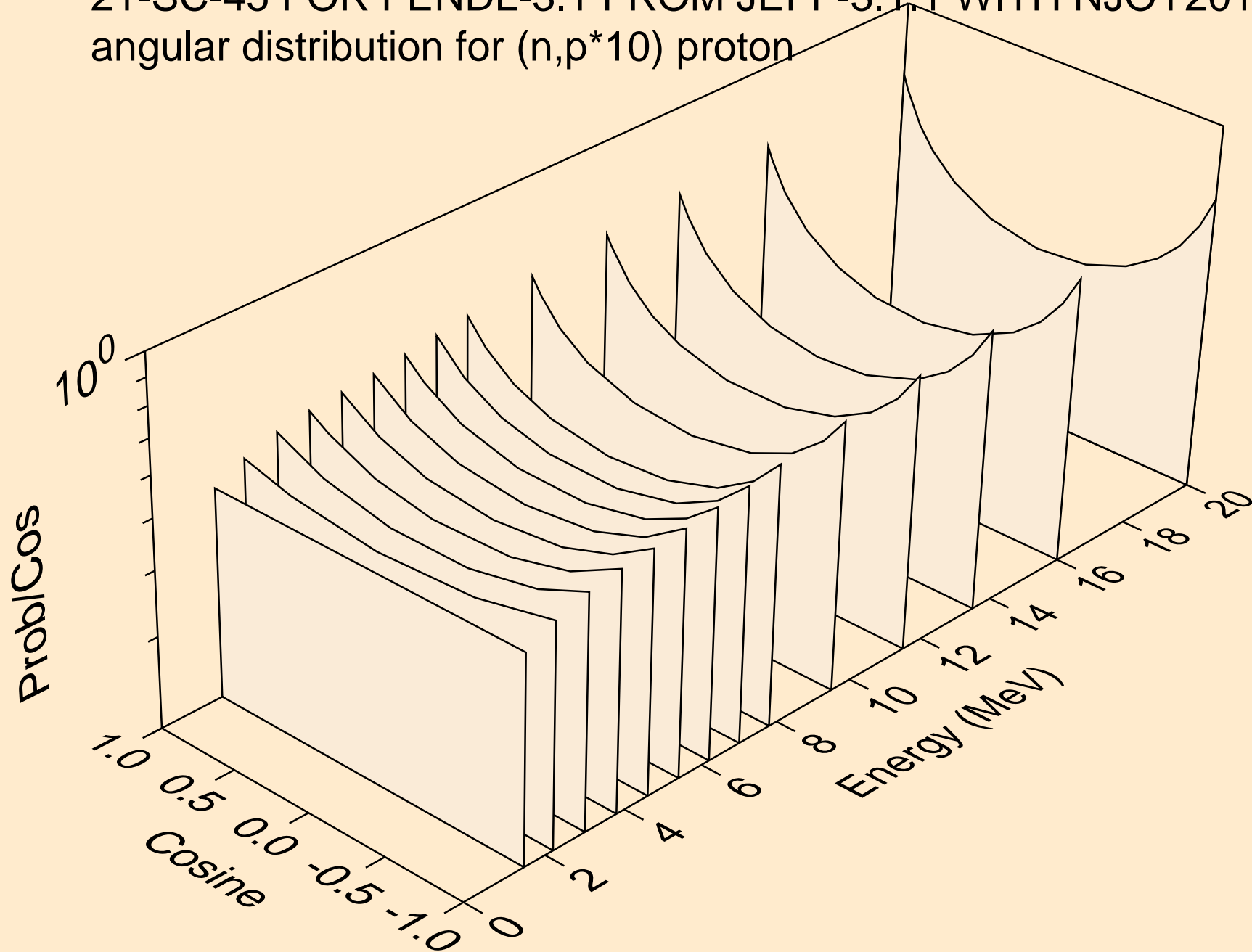



21-SC-45 FOR FENDL-3.1 FROM JEFF-3.1.1 WITH NJOY2012.50+  
protons from (n,p\*c)

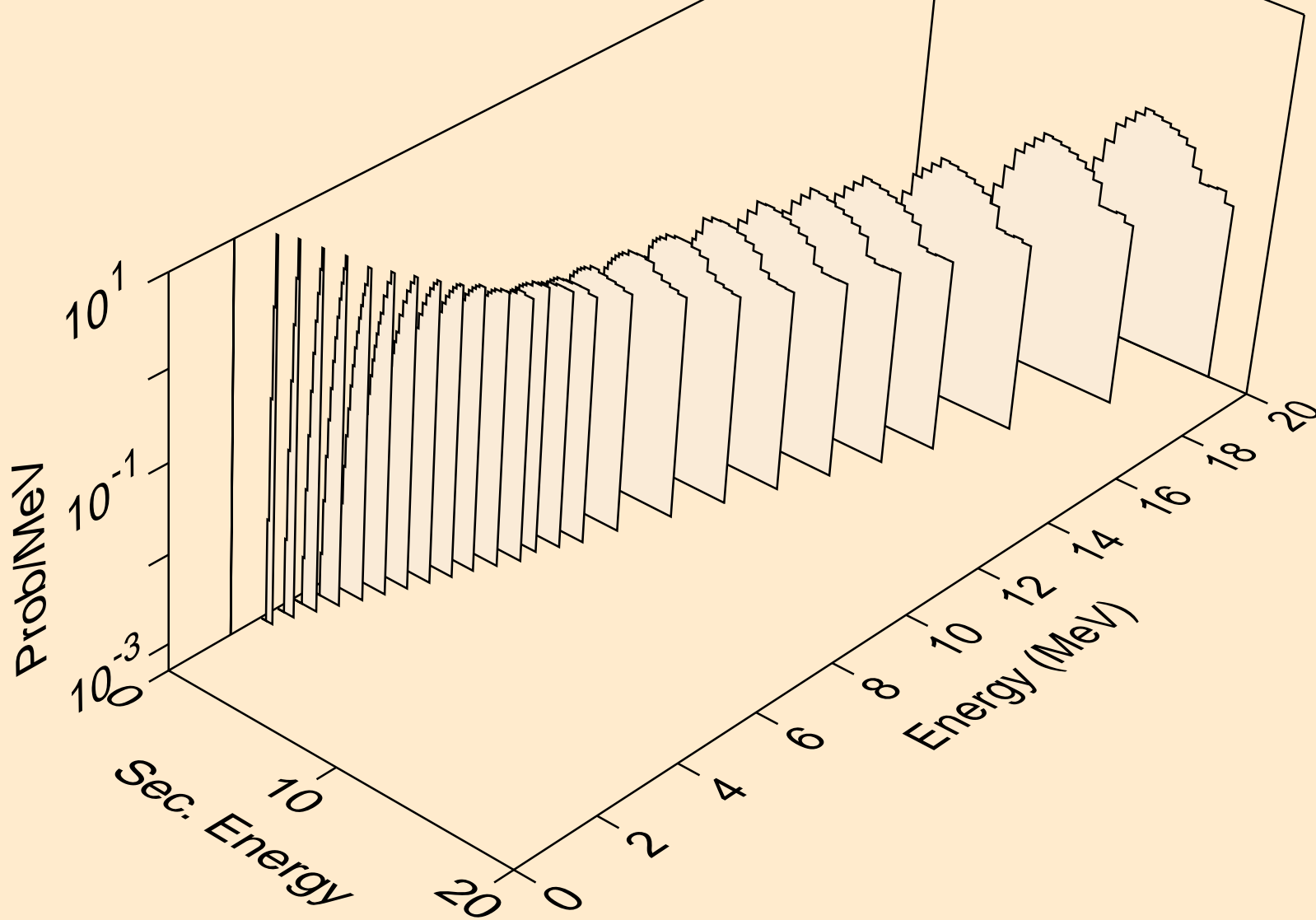

21-SC-45 FOR FENDL-3.1 FROM JEFF-3.1.1 WITH NJOY2012.50+  
deuterons from (n,x)

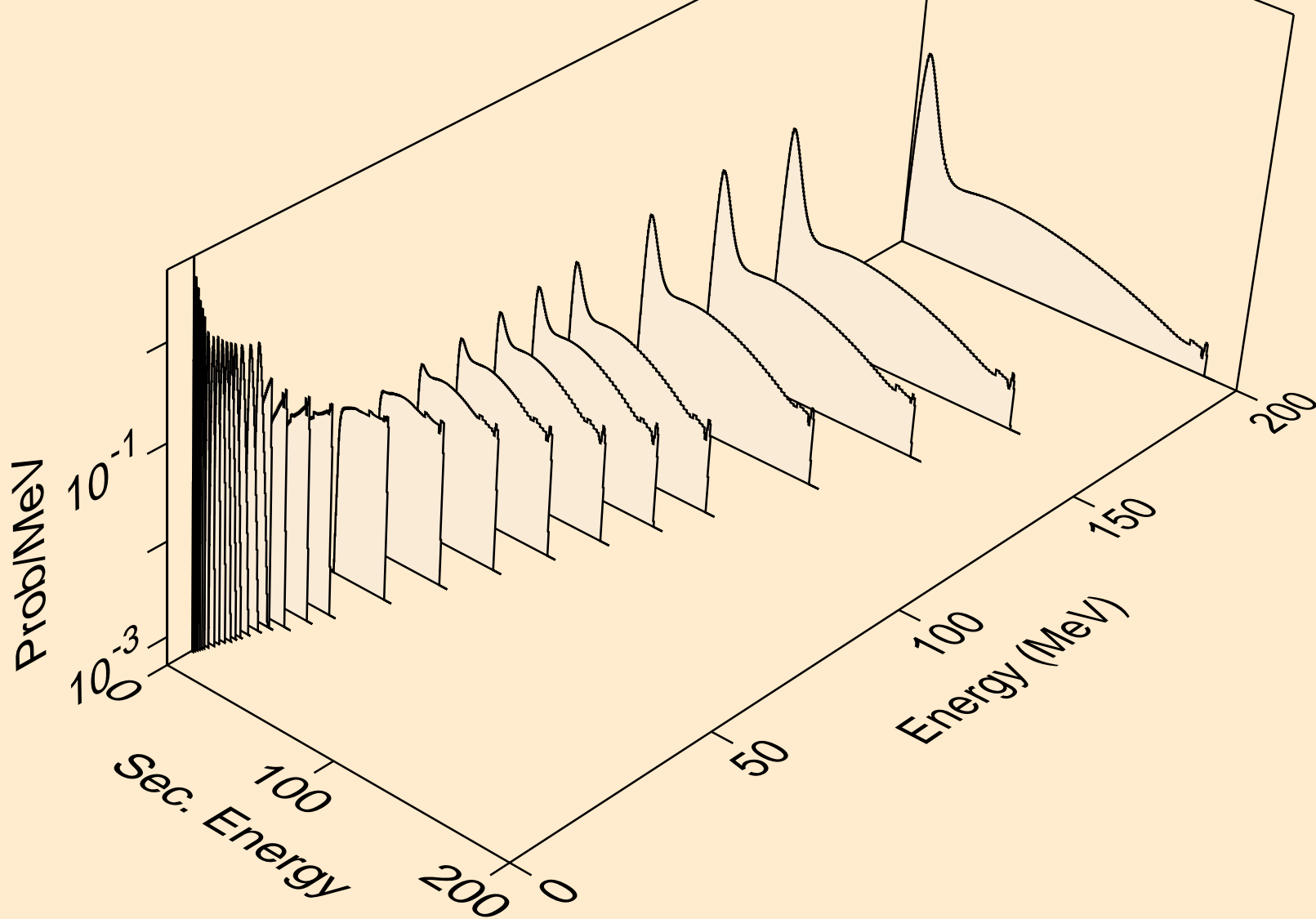

21-SC-45 FOR FENDL-3.1 FROM JEFF-3.1.1 WITH NJOY2012.50+  
deuterons from (n,n\*)d

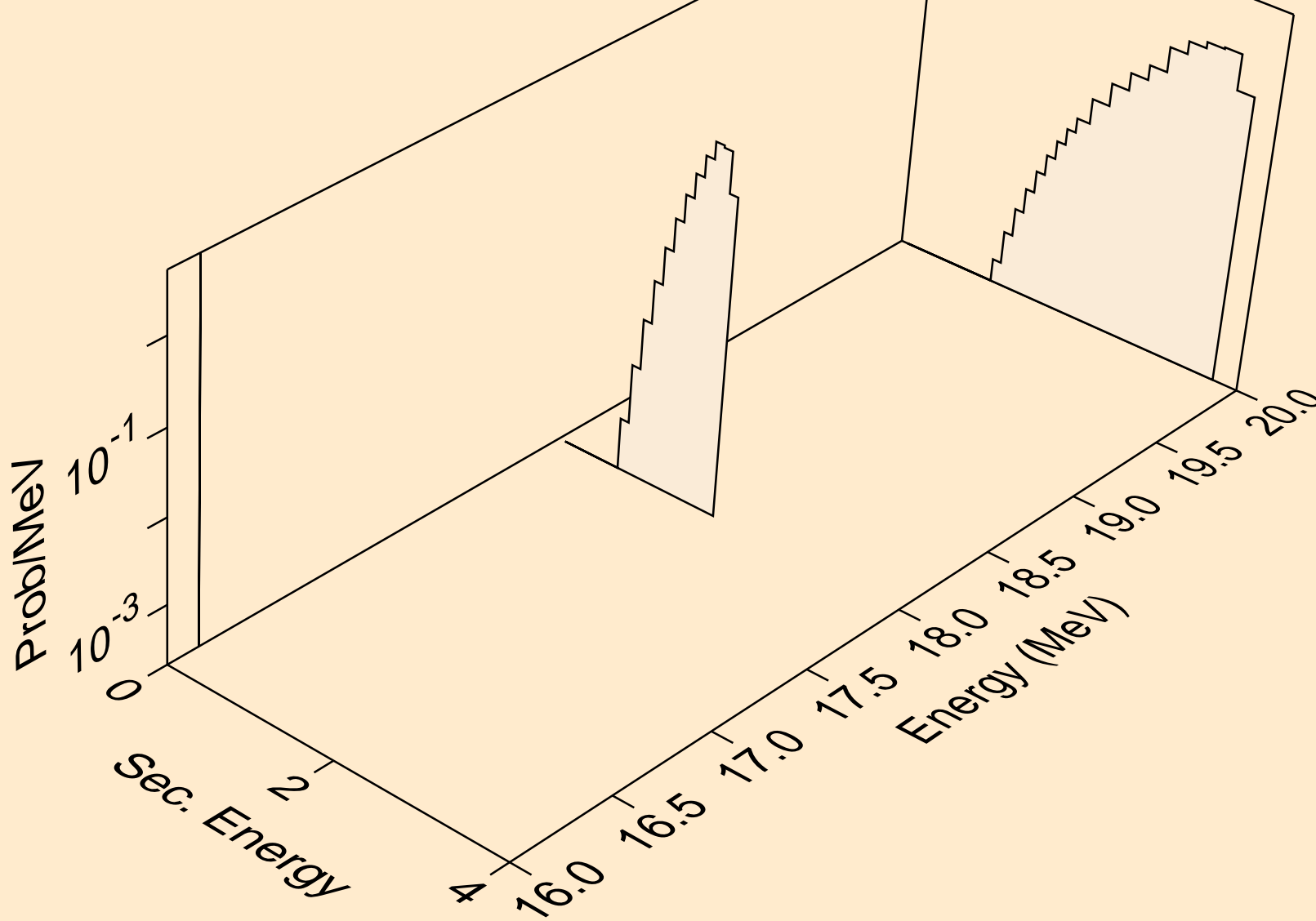

21-SC-45 FOR FENDL-3.1 FROM JEFF-3.1.1 WITH NJOY2012.50+  
deuterons from (n,da)

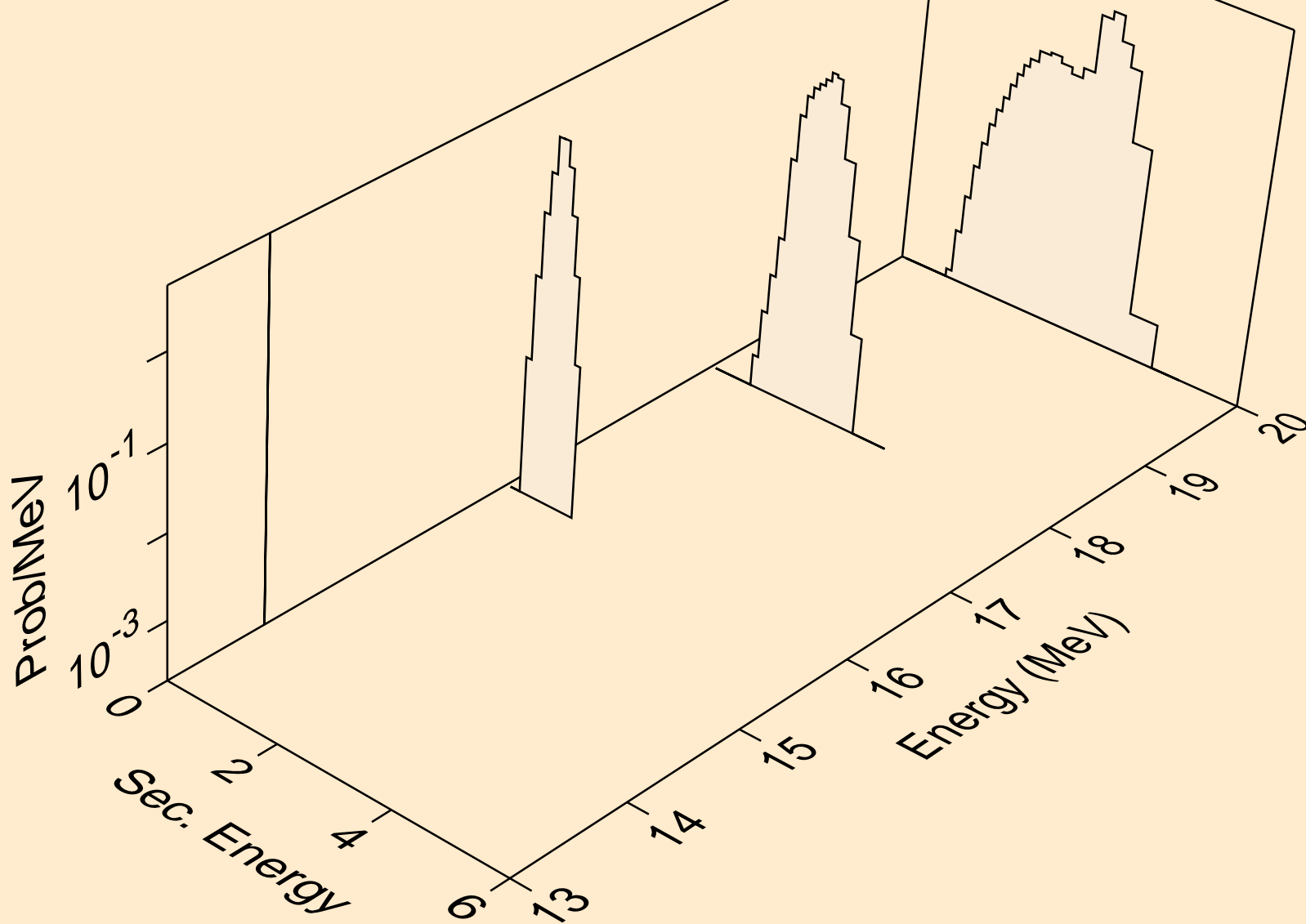

21-SC-45 FOR FENDL-3.1 FROM JEFF-3.1.1 WITH NJOY2012.50+  
angular distribution for (n,d\*0) deuteron

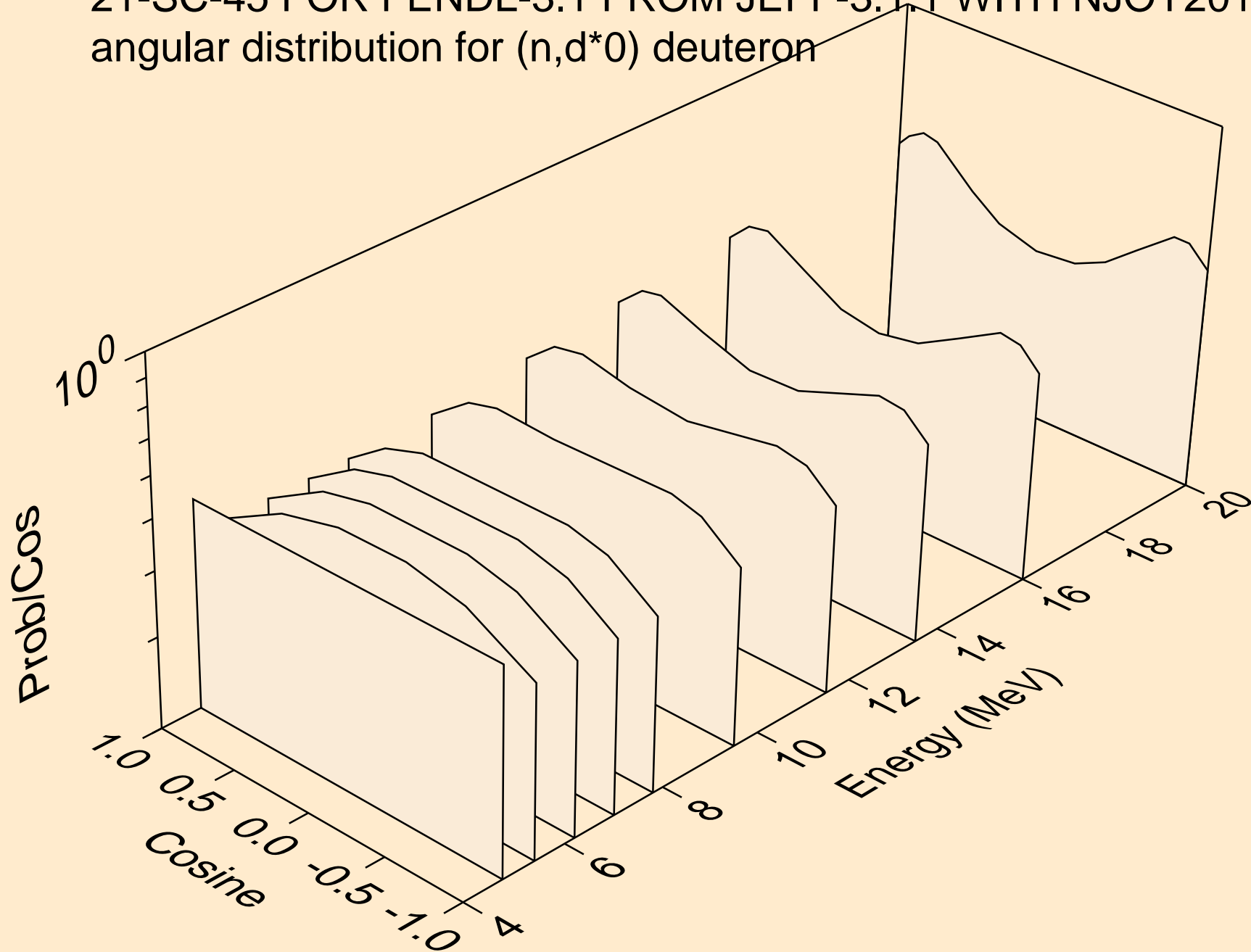

21-SC-45 FOR FENDL-3.1 FROM JEFF-3.1.1 WITH NJOY2012.50+  
angular distribution for (n,d\*1) deuteron

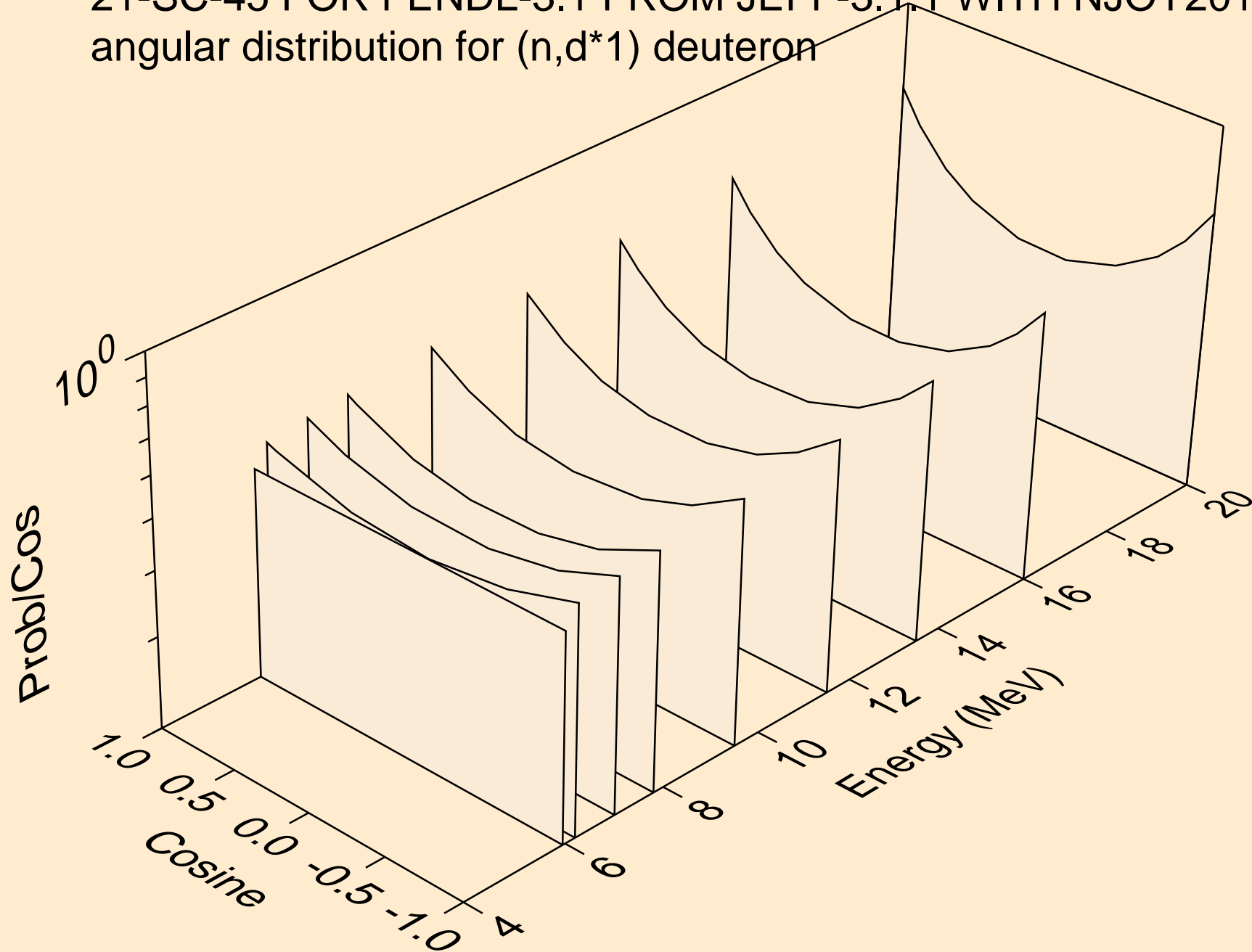

21-SC-45 FOR FENDL-3.1 FROM JEFF-3.1.1 WITH NJOY2012.50+  
angular distribution for (n,d\*2) deuteron

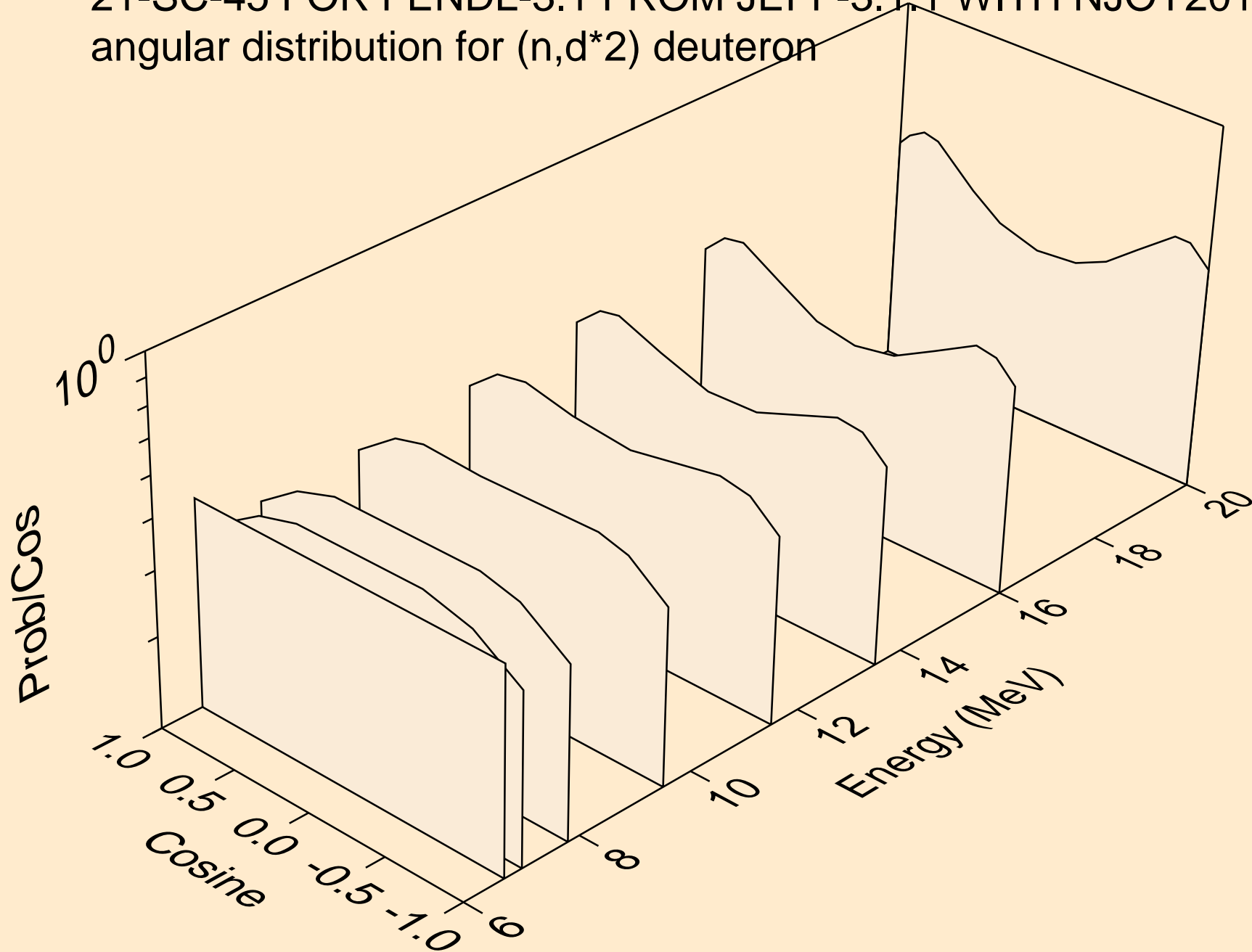

21-SC-45 FOR FENDL-3.1 FROM JEFF-3.1.1 WITH NJOY2012.50+  
angular distribution for (n,d\*3) deuteron

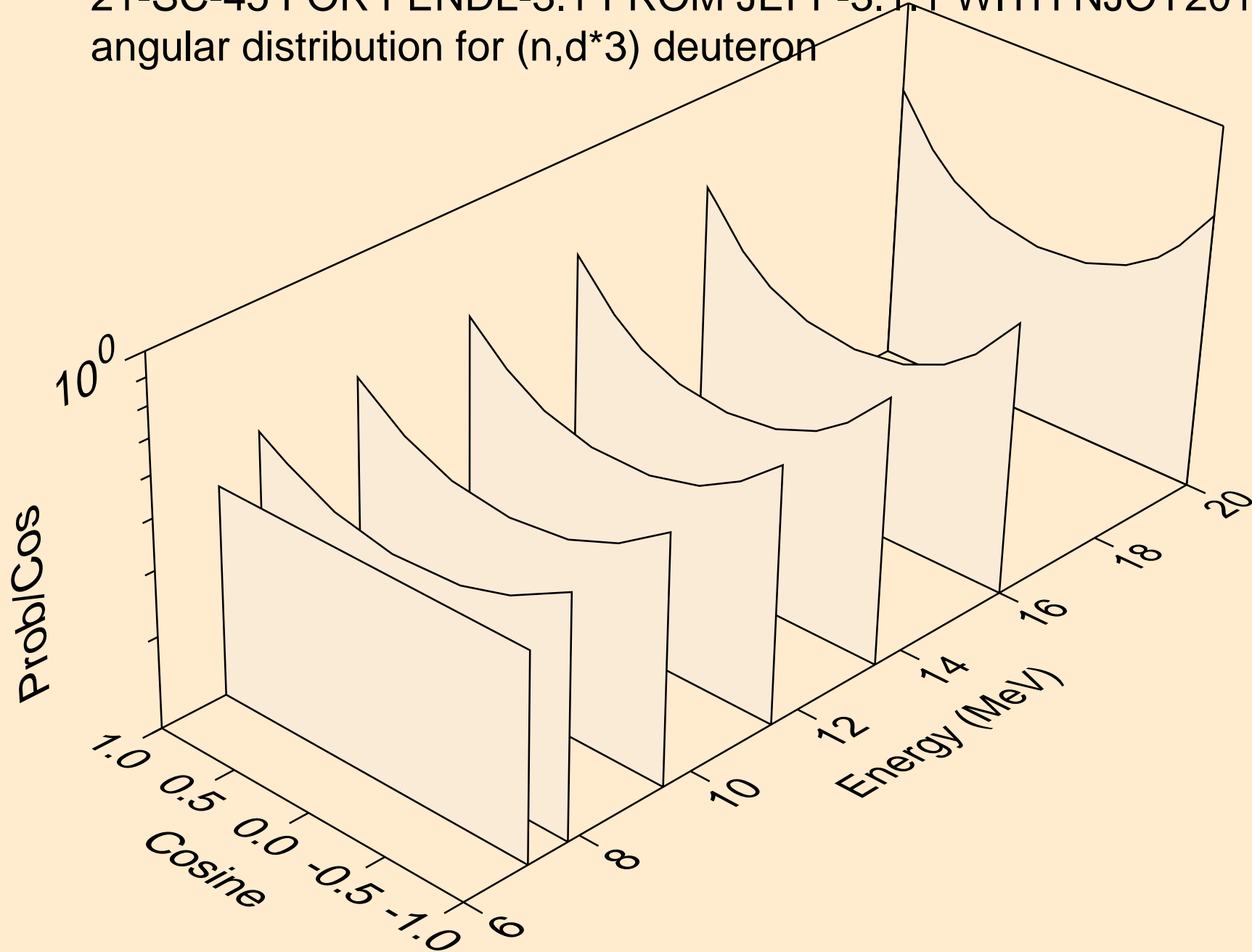



21-SC-45 FOR FENDL-3.1 FROM JEFF-3.1.1 WITH NJOY2012.50+  
angular distribution for (n,d\*4) deuteron

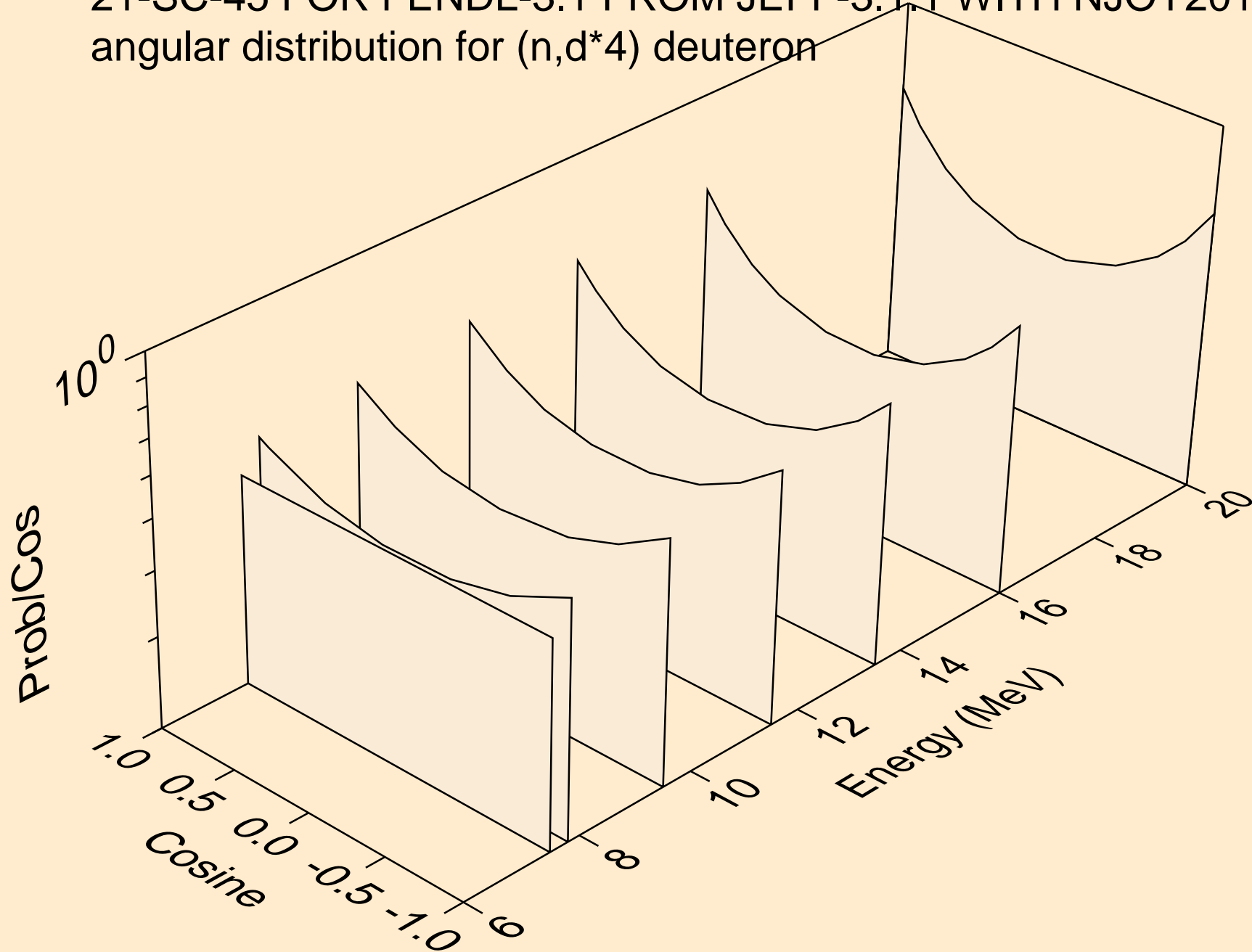

21-SC-45 FOR FENDL-3.1 FROM JEFF-3.1.1 WITH NJOY2012.50+  
angular distribution for (n,d\*5) deuteron

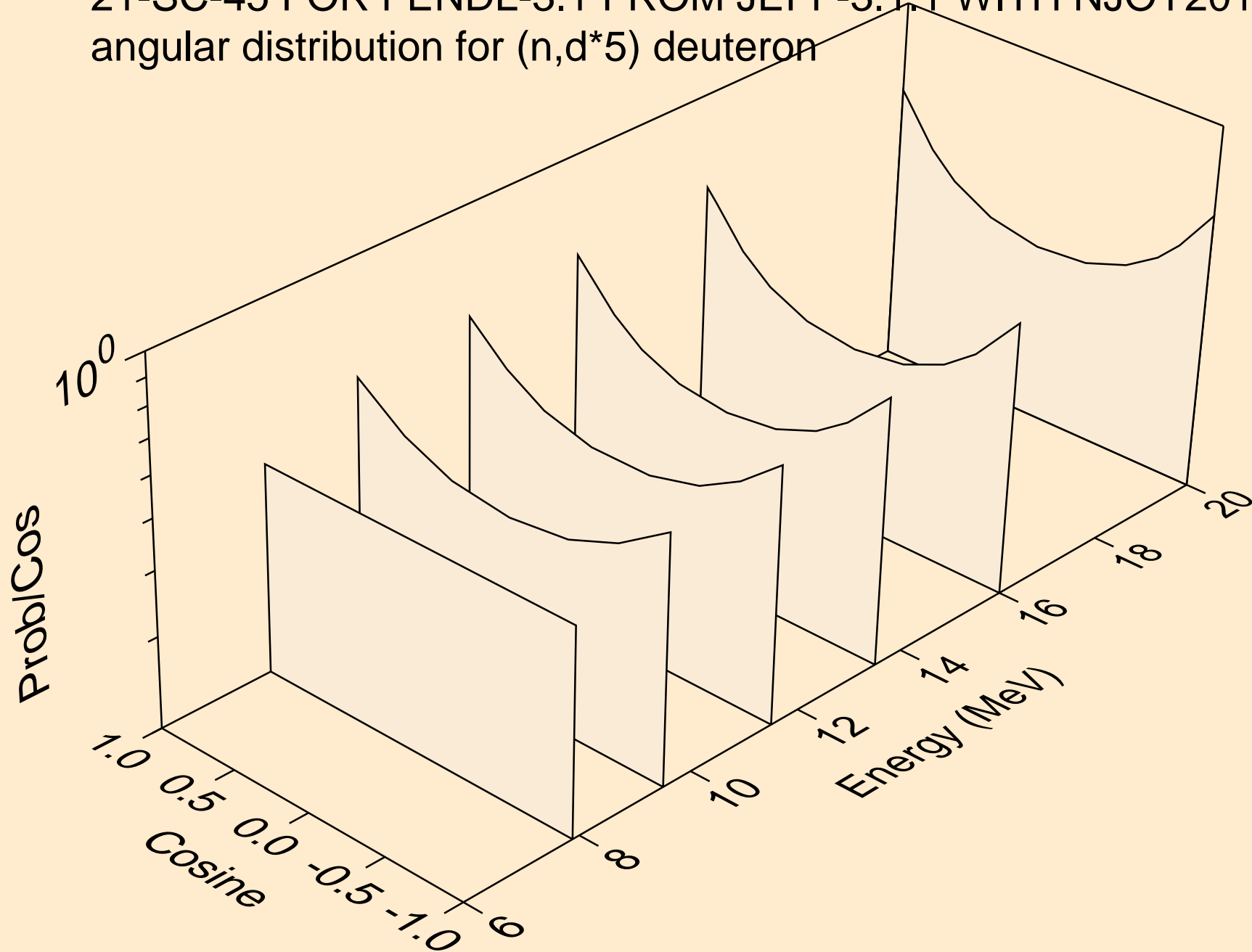

21-SC-45 FOR FENDL-3.1 FROM JEFF-3.1.1 WITH NJOY2012.50+  
deuterons from (n,d\*c)

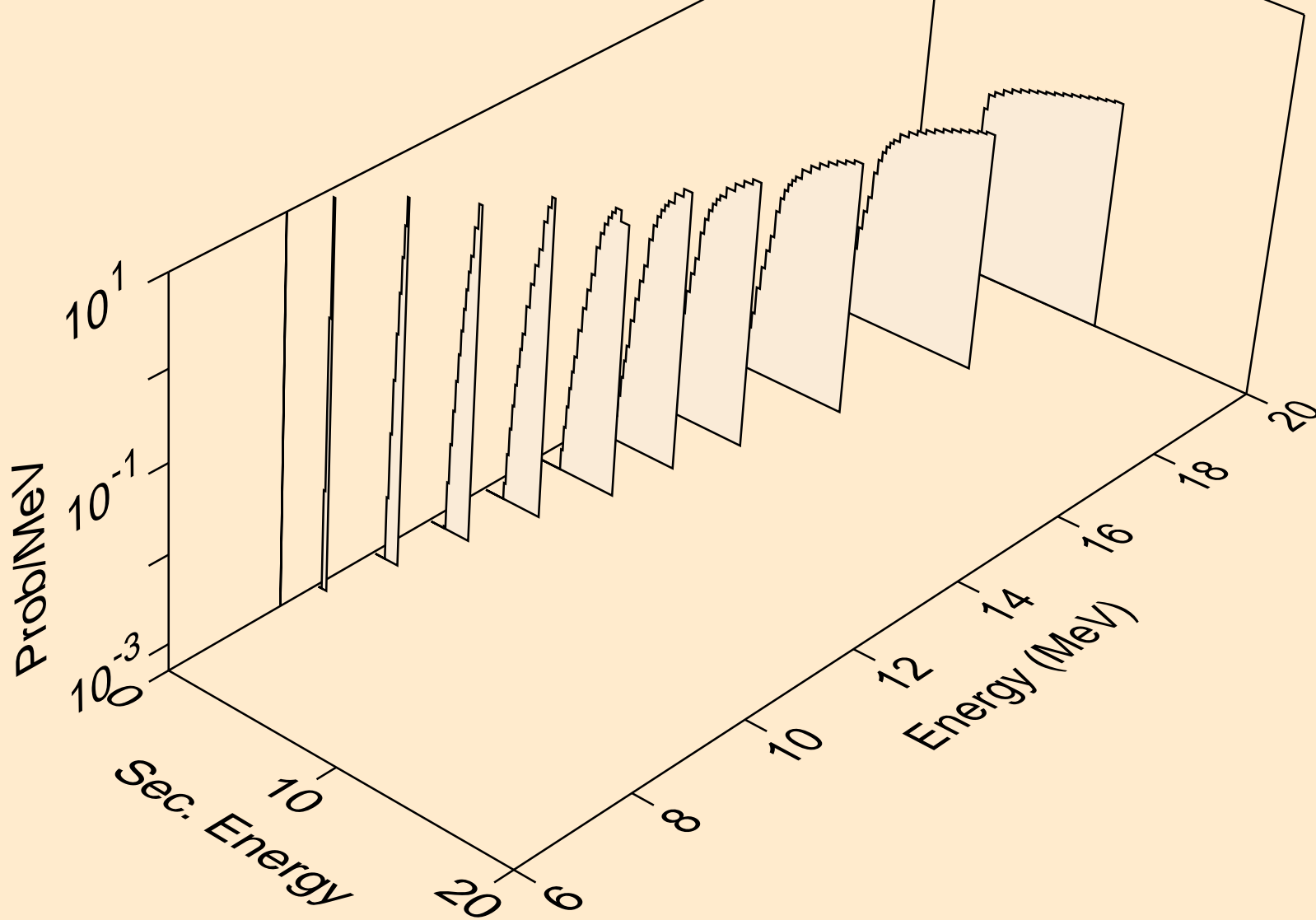

21-SC-45 FOR FENDL-3.1 FROM JEFF-3.1.1 WITH NJOY2012.50+  
tritons from (n,x)

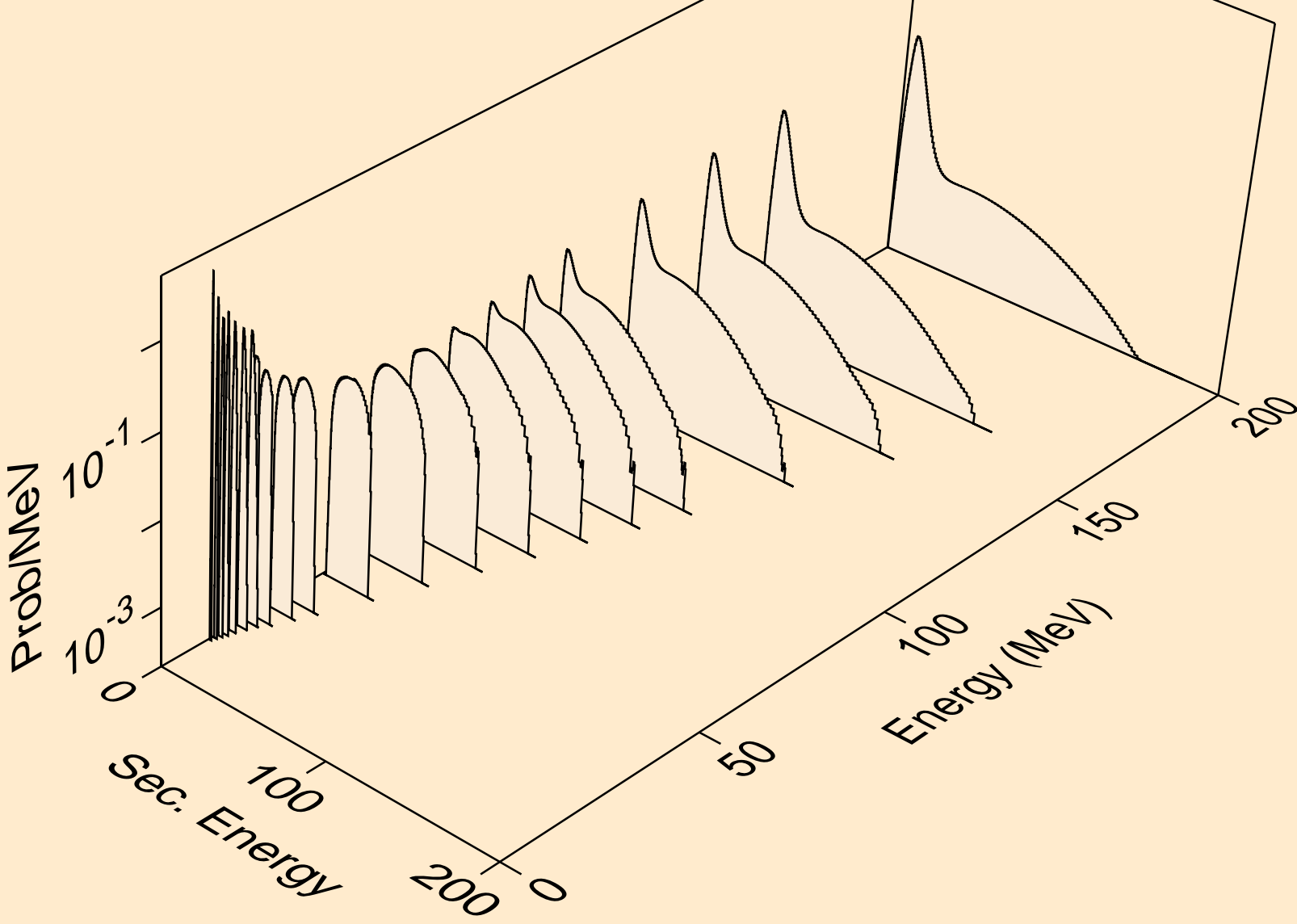

21-SC-45 FOR FENDL-3.1 FROM JEFF-3.1.1 WITH NJOY2012.50+  
tritons from (n,n\*)t

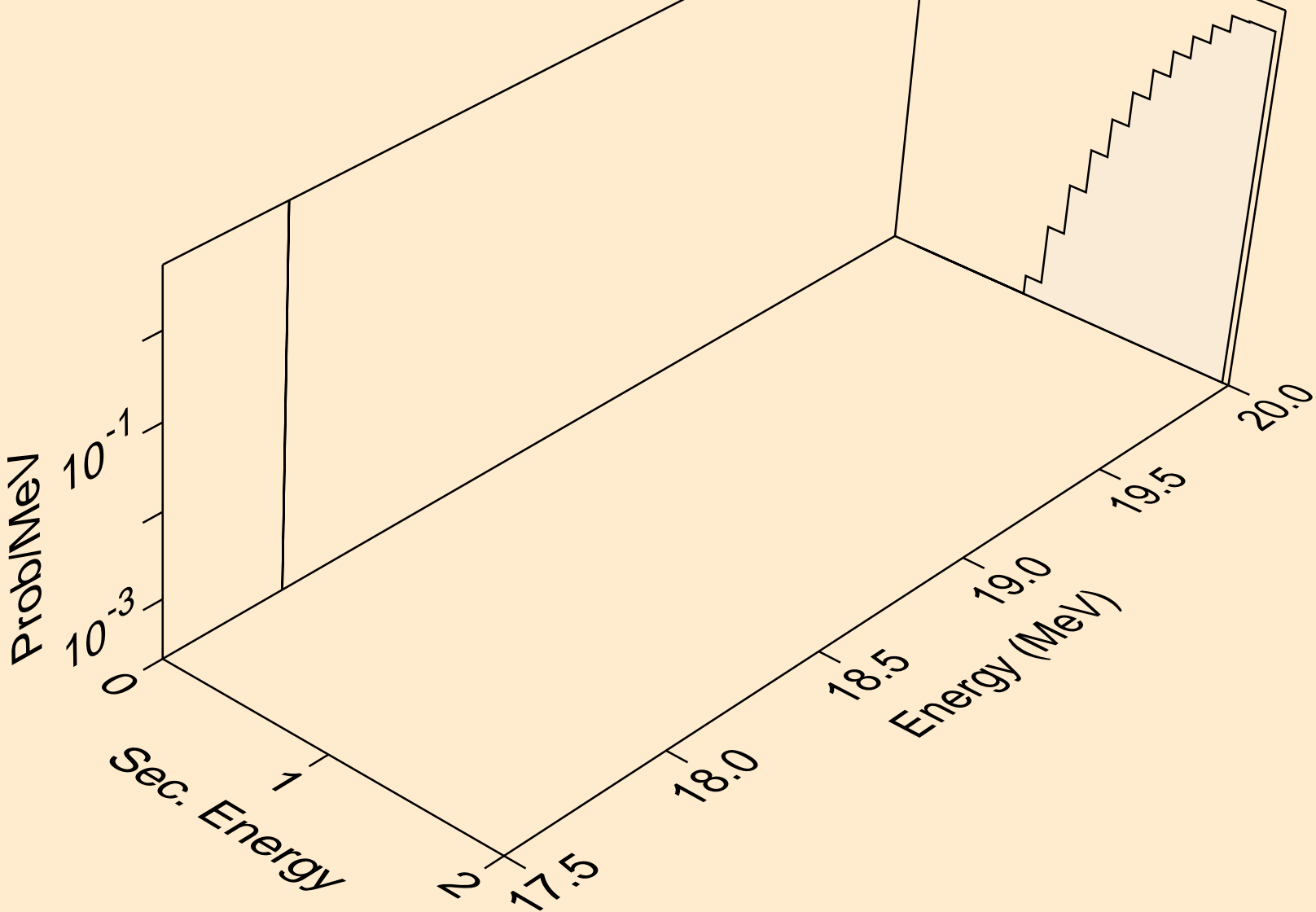

21-SC-45 FOR FENDL-3.1 FROM JEFF-3.1.1 WITH NJOY2012.50+  
angular distribution for (n,t\*0) triton

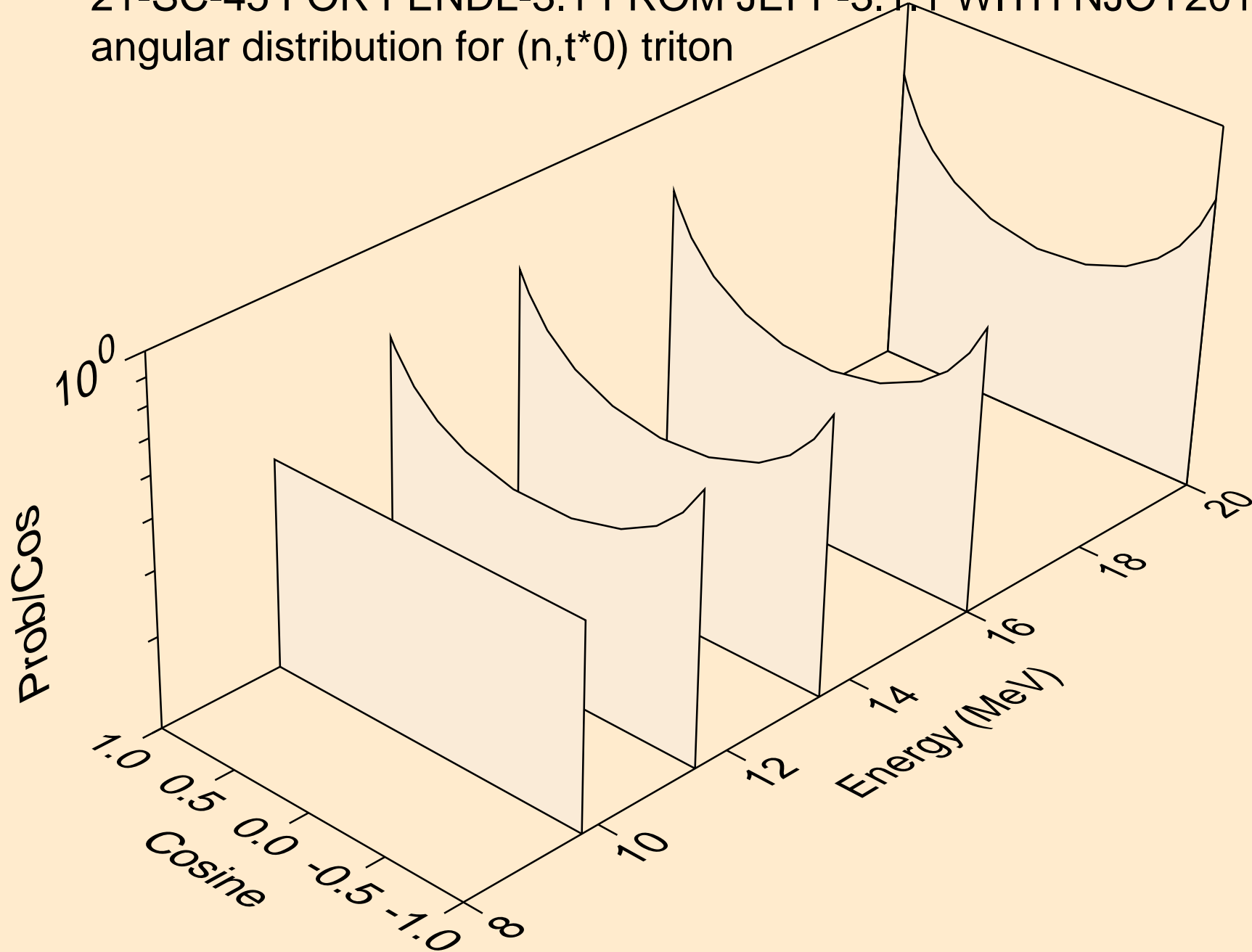

21-SC-45 FOR FENDL-3.1 FROM JEFF-3.1.1 WITH NJOY2012.50+  
angular distribution for (n,t\*1) triton

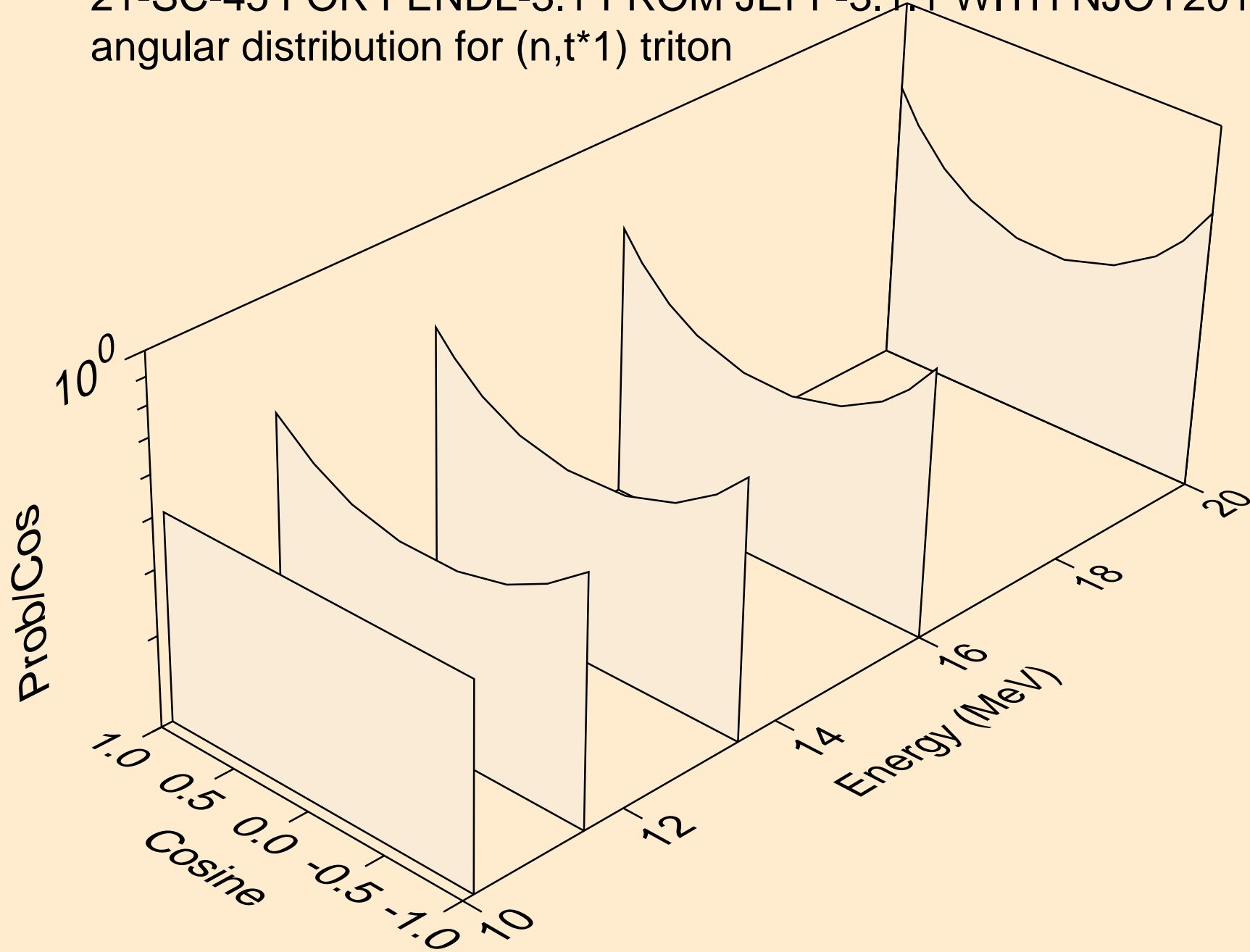

21-SC-45 FOR FENDL-3.1 FROM JEFF-3.1.1 WITH NJOY2012.50+  
angular distribution for (n,t\*2) triton

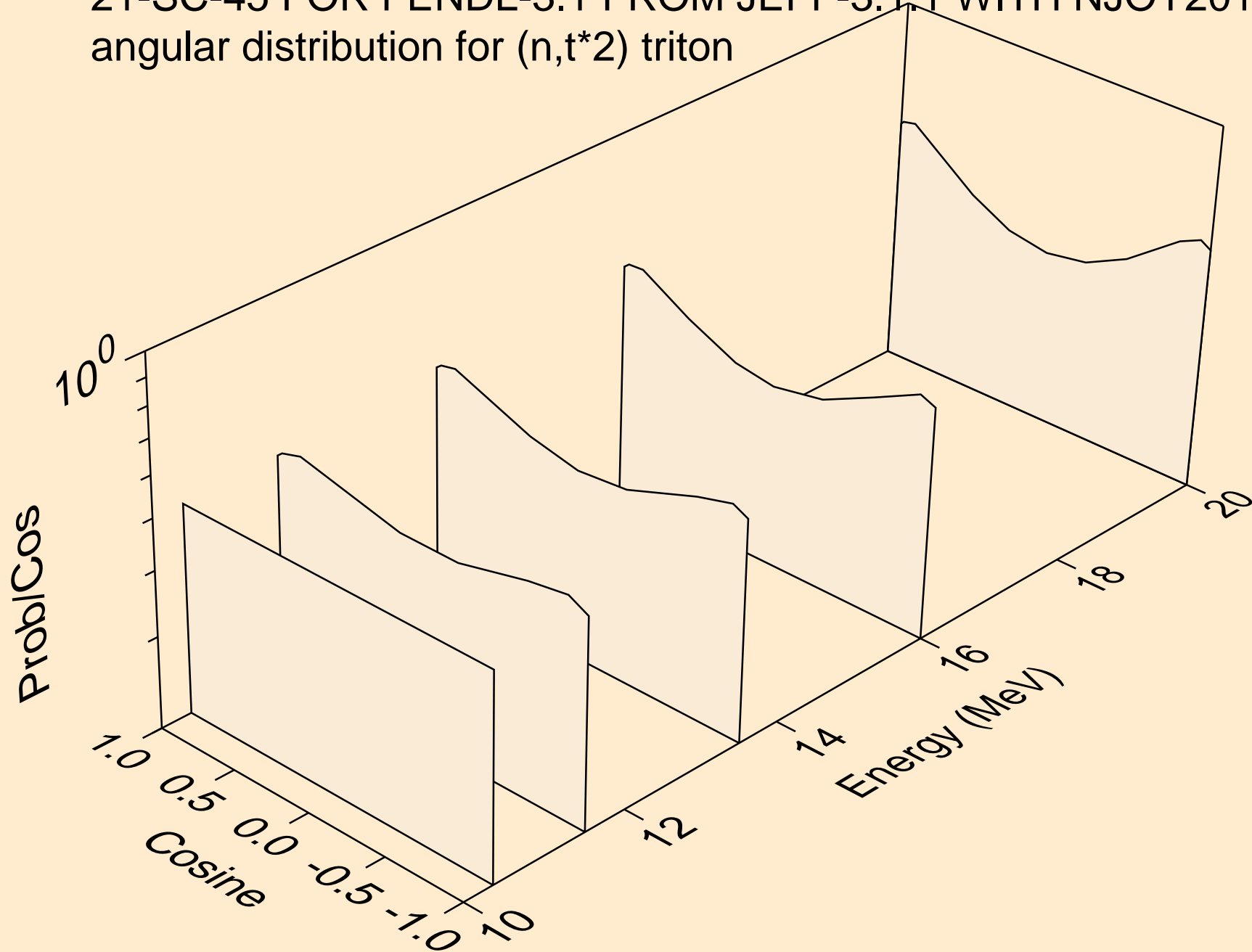



21-SC-45 FOR FENDL-3.1 FROM JEFF-3.1.1 WITH NJOY2012.50+  
angular distribution for (n,t\*3) triton

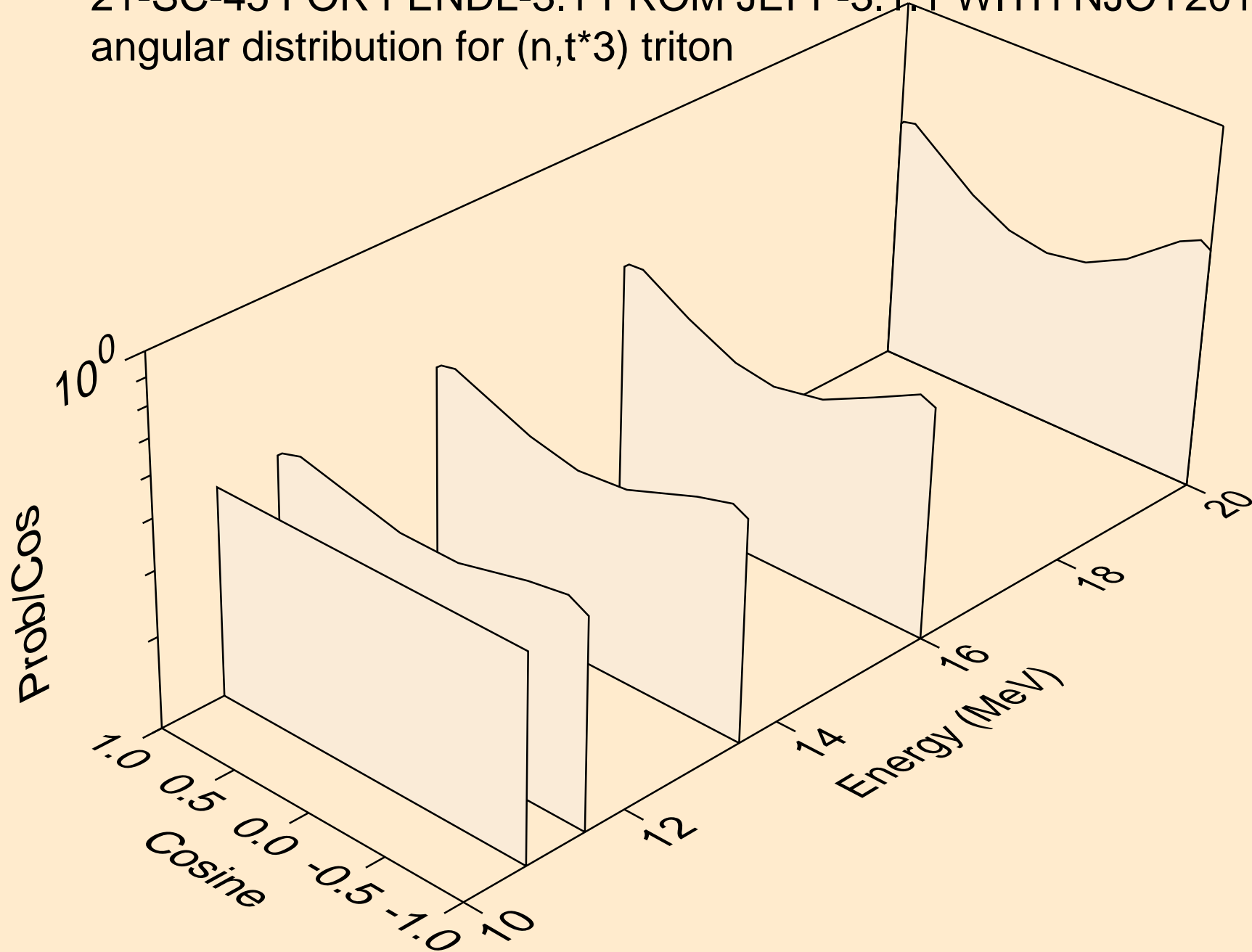

21-SC-45 FOR FENDL-3.1 FROM JEFF-3.1.1 WITH NJOY2012.50+  
angular distribution for (n,t\*4) triton

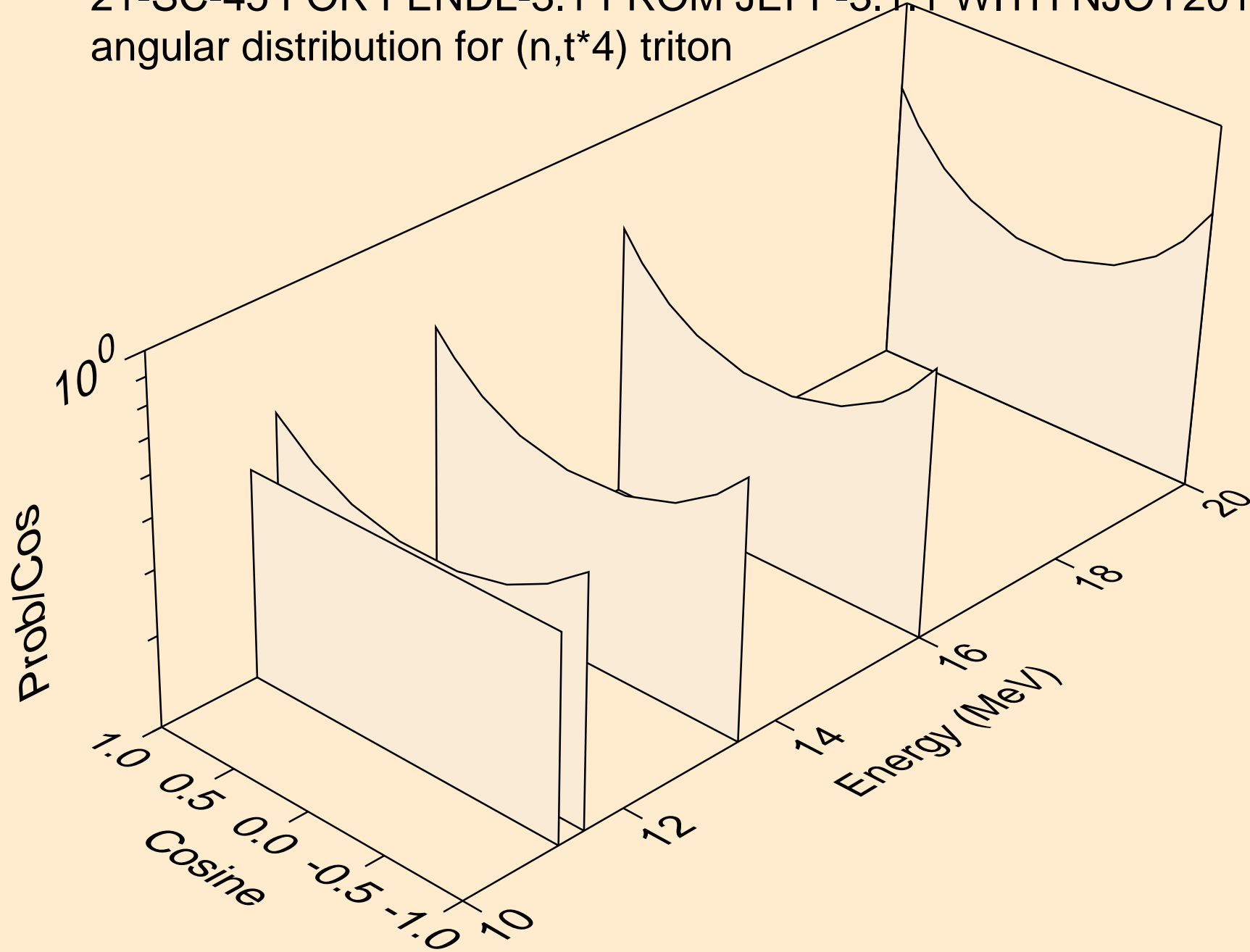

21-SC-45 FOR FENDL-3.1 FROM JEFF-3.1.1 WITH NJOY2012.50+  
angular distribution for (n,t\*5) triton

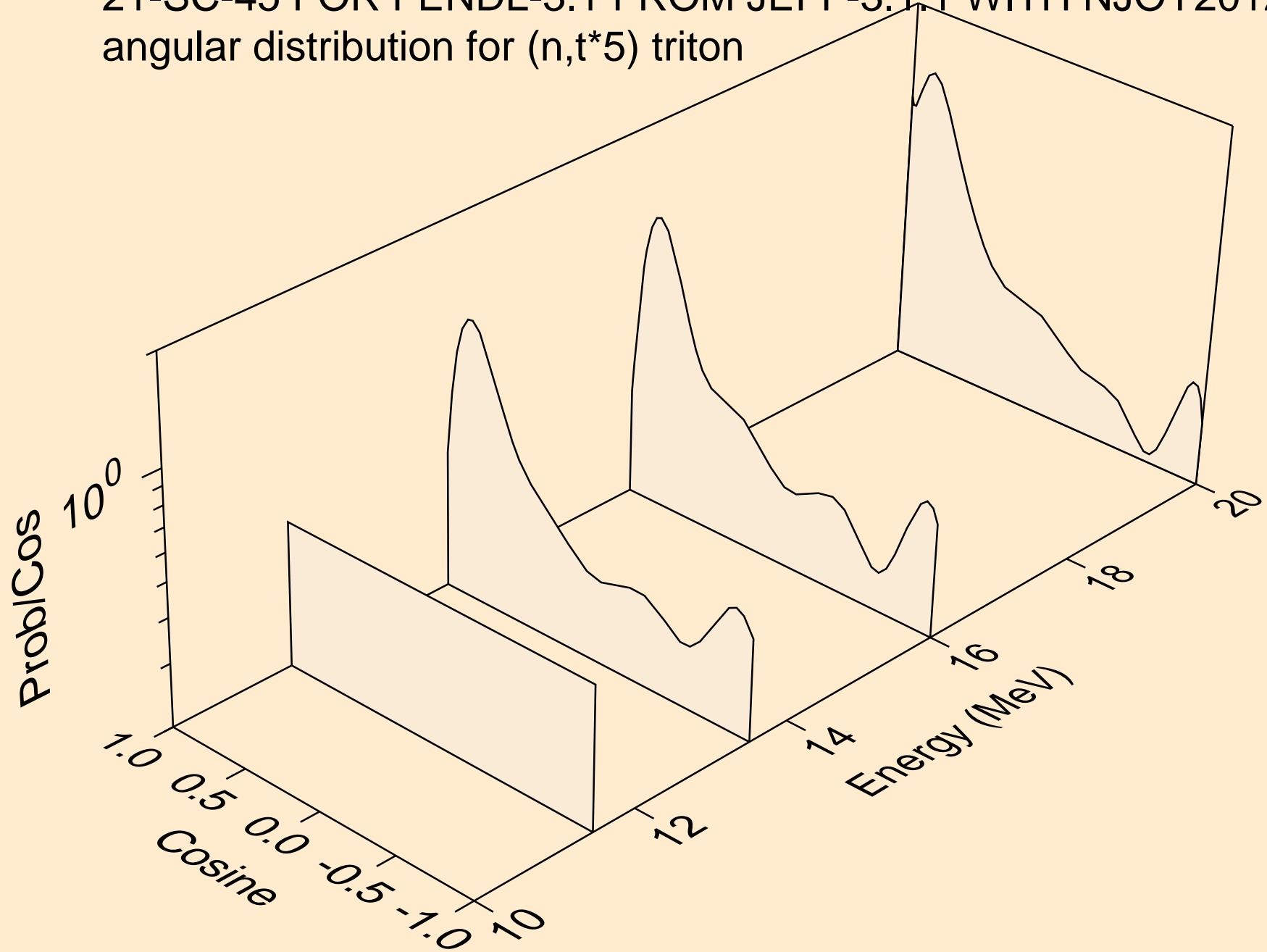

21-SC-45 FOR FENDL-3.1 FROM JEFF-3.1.1 WITH NJOY2012.50+  
tritons from (n,t\*c)

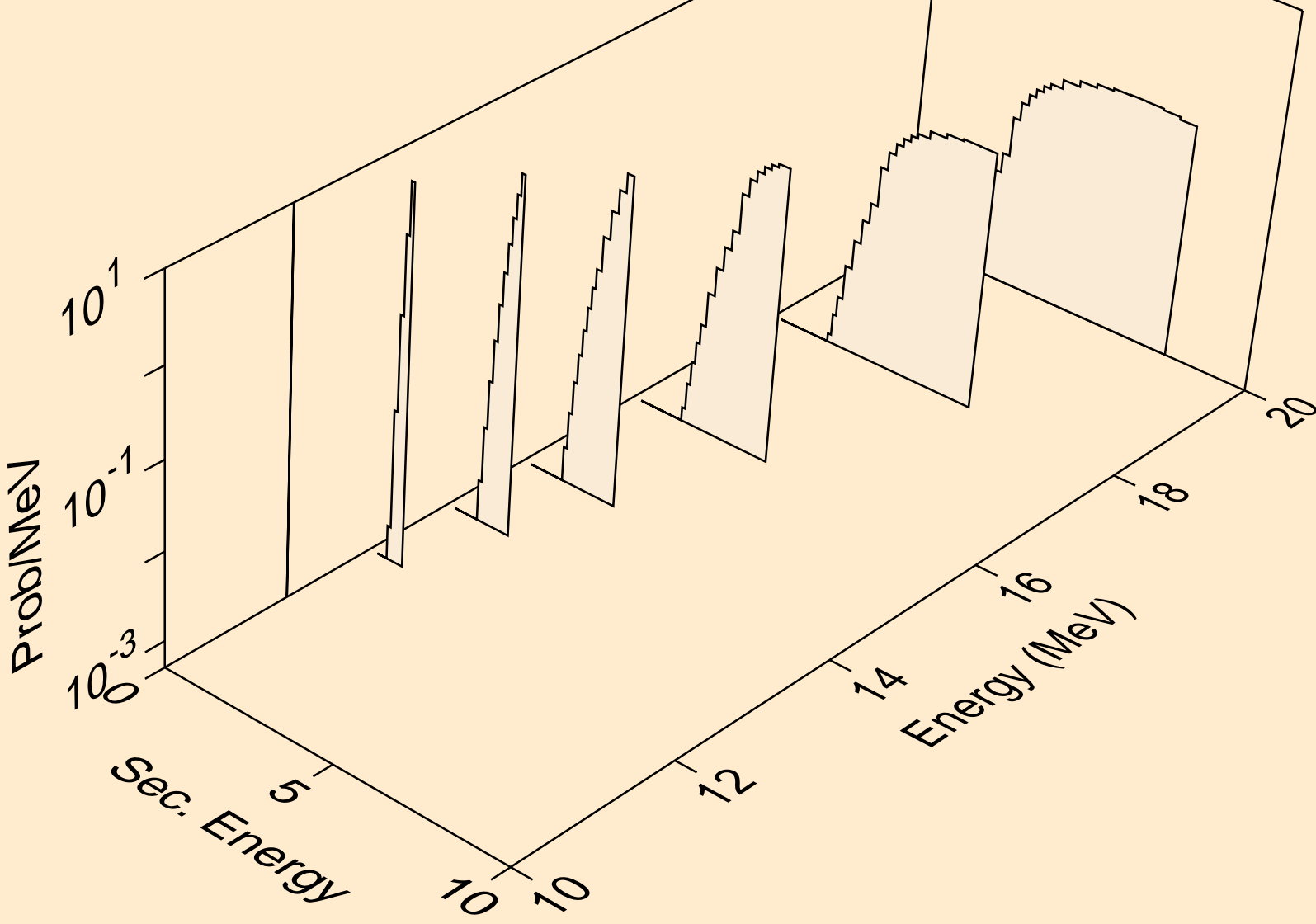

21-SC-45 FOR FENDL-3.1 FROM JEFF-3.1.1 WITH NJOY2012.50+  
he3s from (n,x)

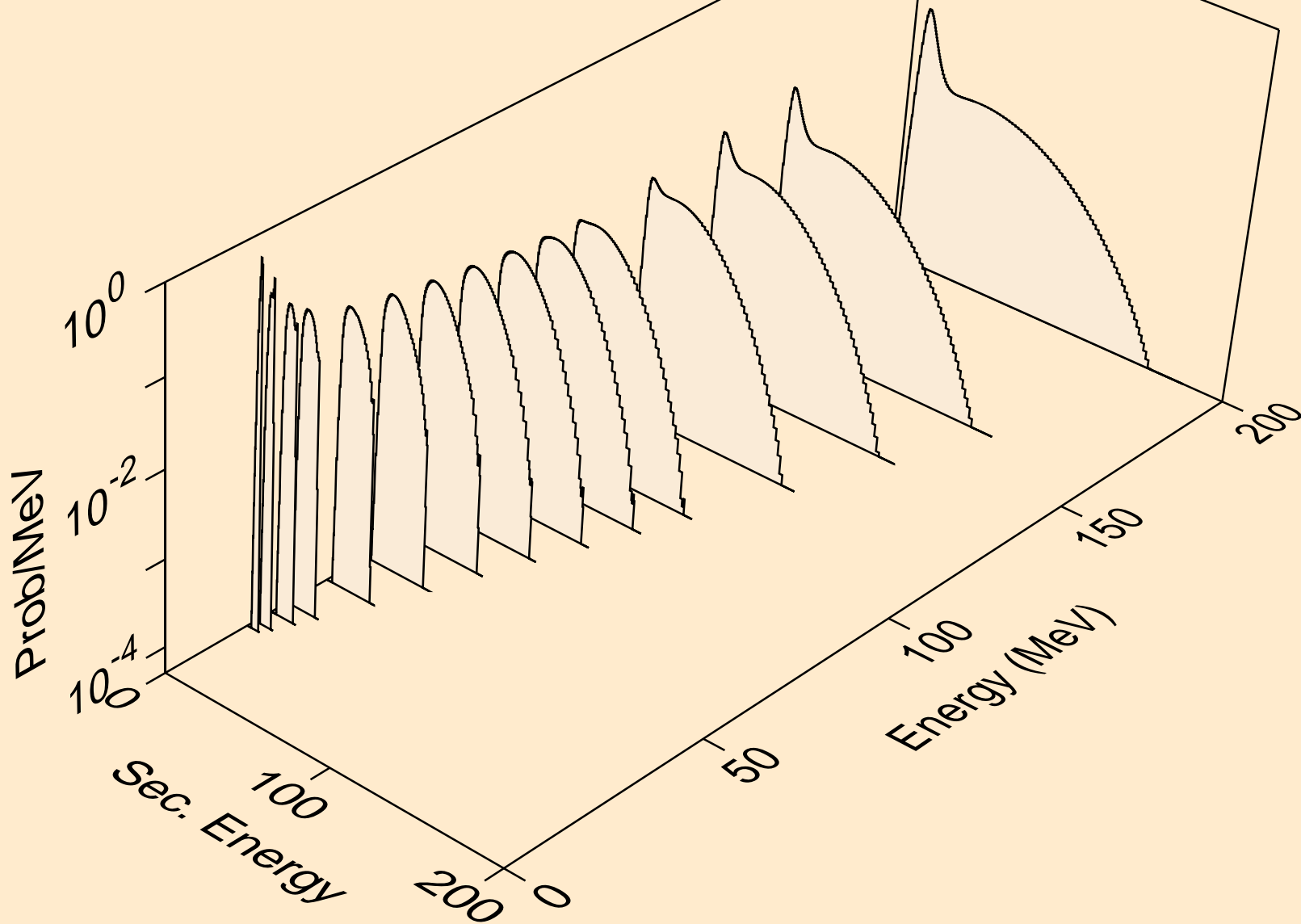

21-SC-45 FOR FENDL-3.1 FROM JEFF-3.1.1 WITH NJOY2012.50+  
angular distribution for (n,he3\*0) 3he

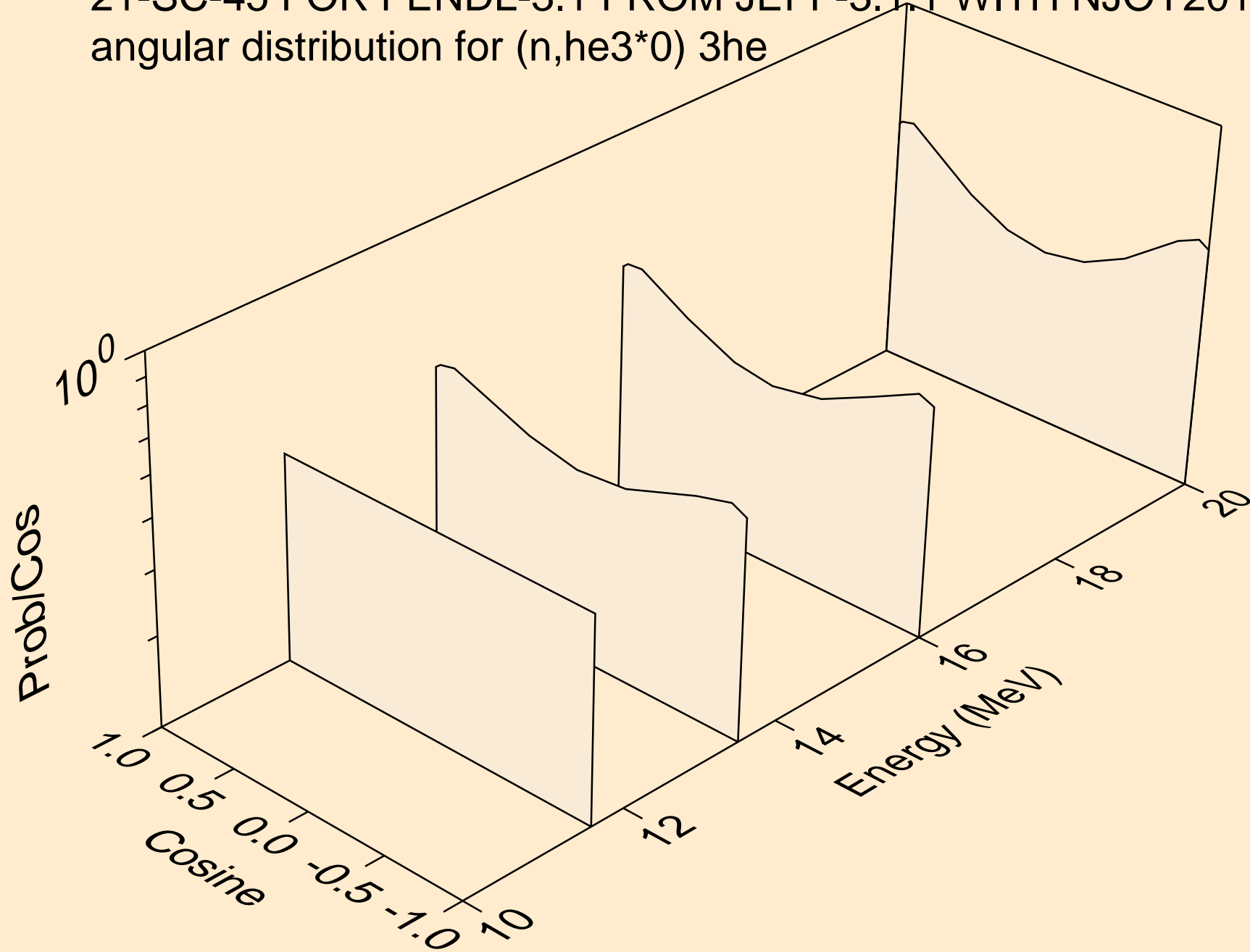

21-SC-45 FOR FENDL-3.1 FROM JEFF-3.1.1 WITH NJOY2012.50+  
angular distribution for (n,he3\*1) 3he

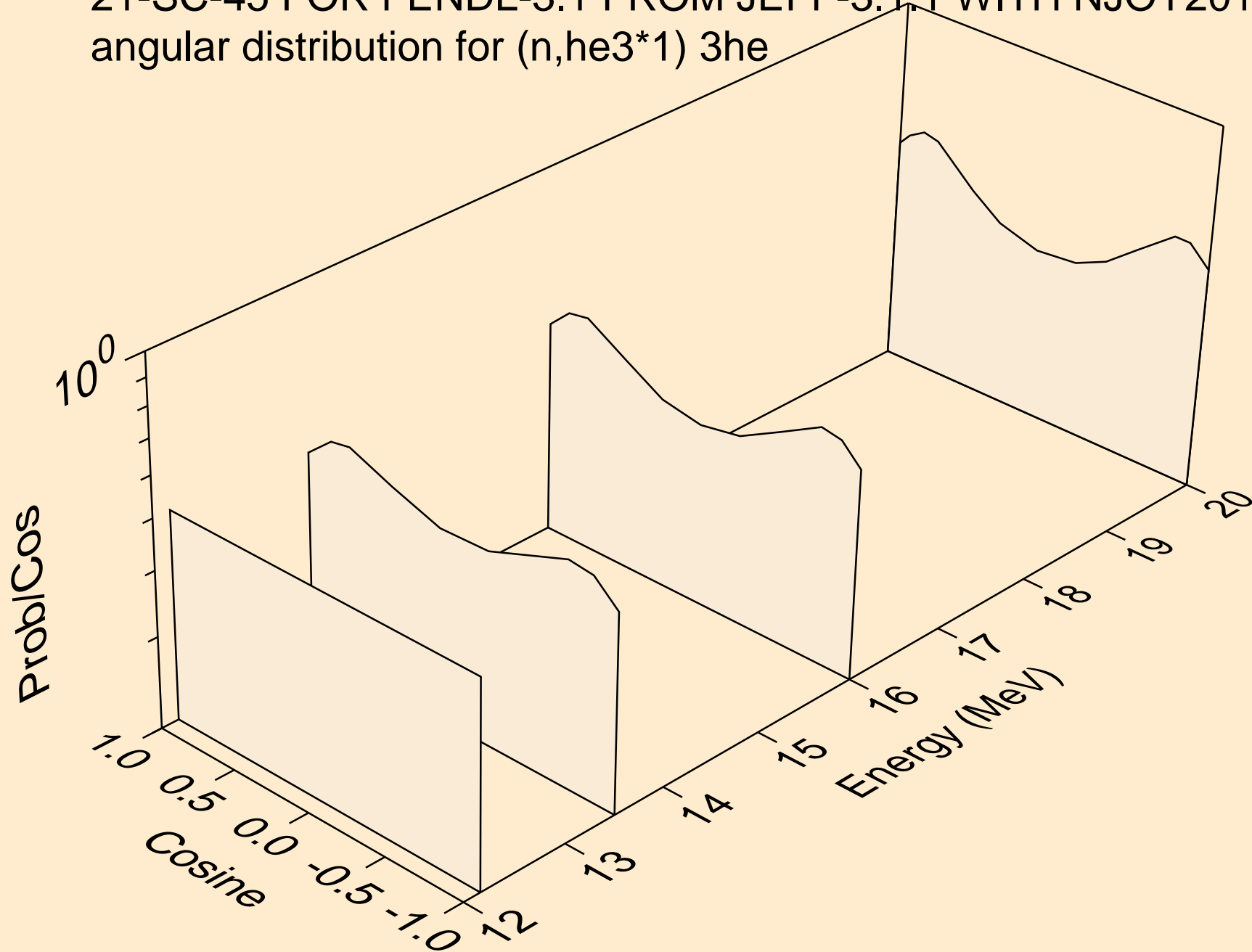

21-SC-45 FOR FENDL-3.1 FROM JEFF-3.1.1 WITH NJOY2012.50+  
angular distribution for (n,he3\*2) 3he

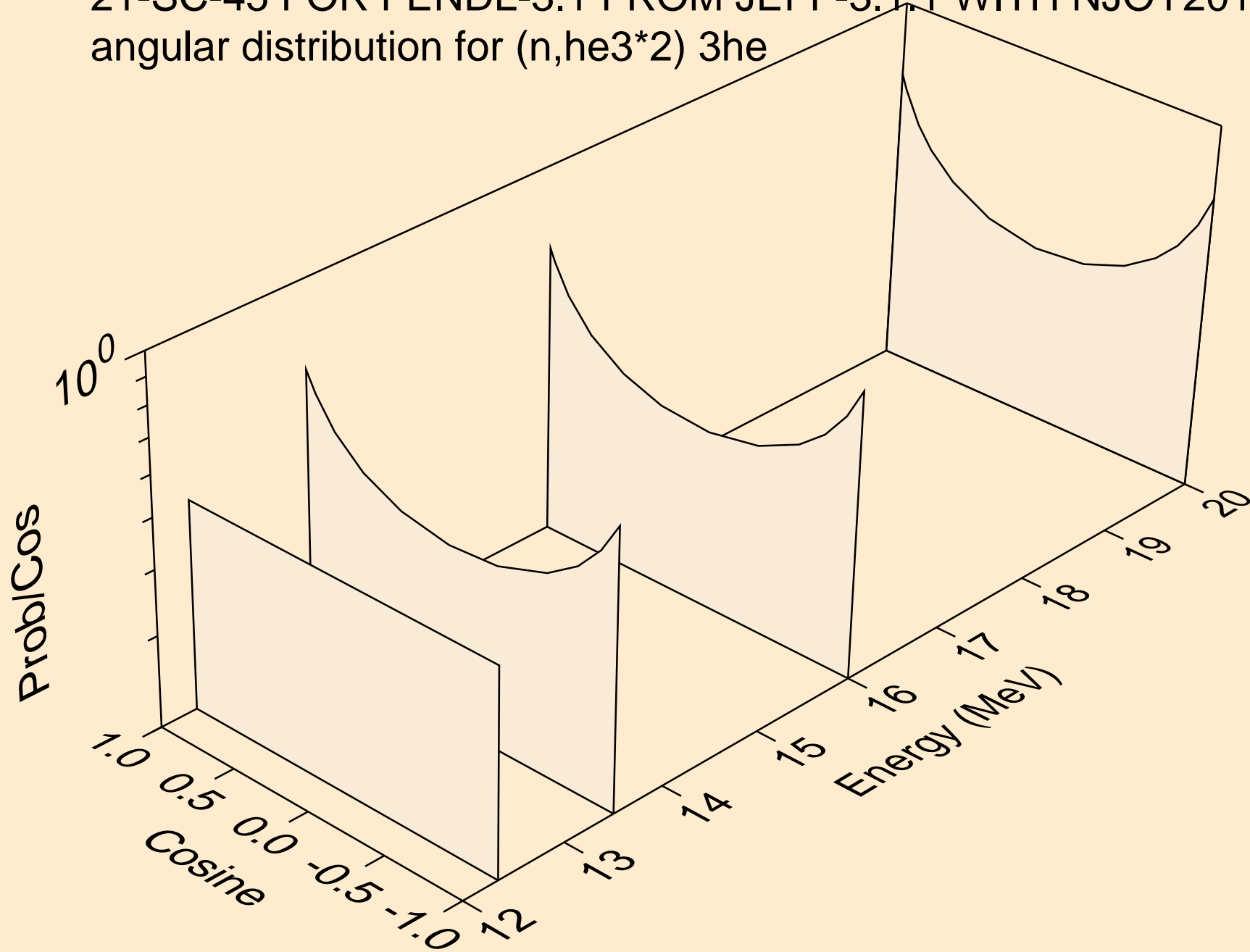



21-SC-45 FOR FENDL-3.1 FROM JEFF-3.1.1 WITH NJOY2012.50+  
angular distribution for (n,he3\*3) 3he

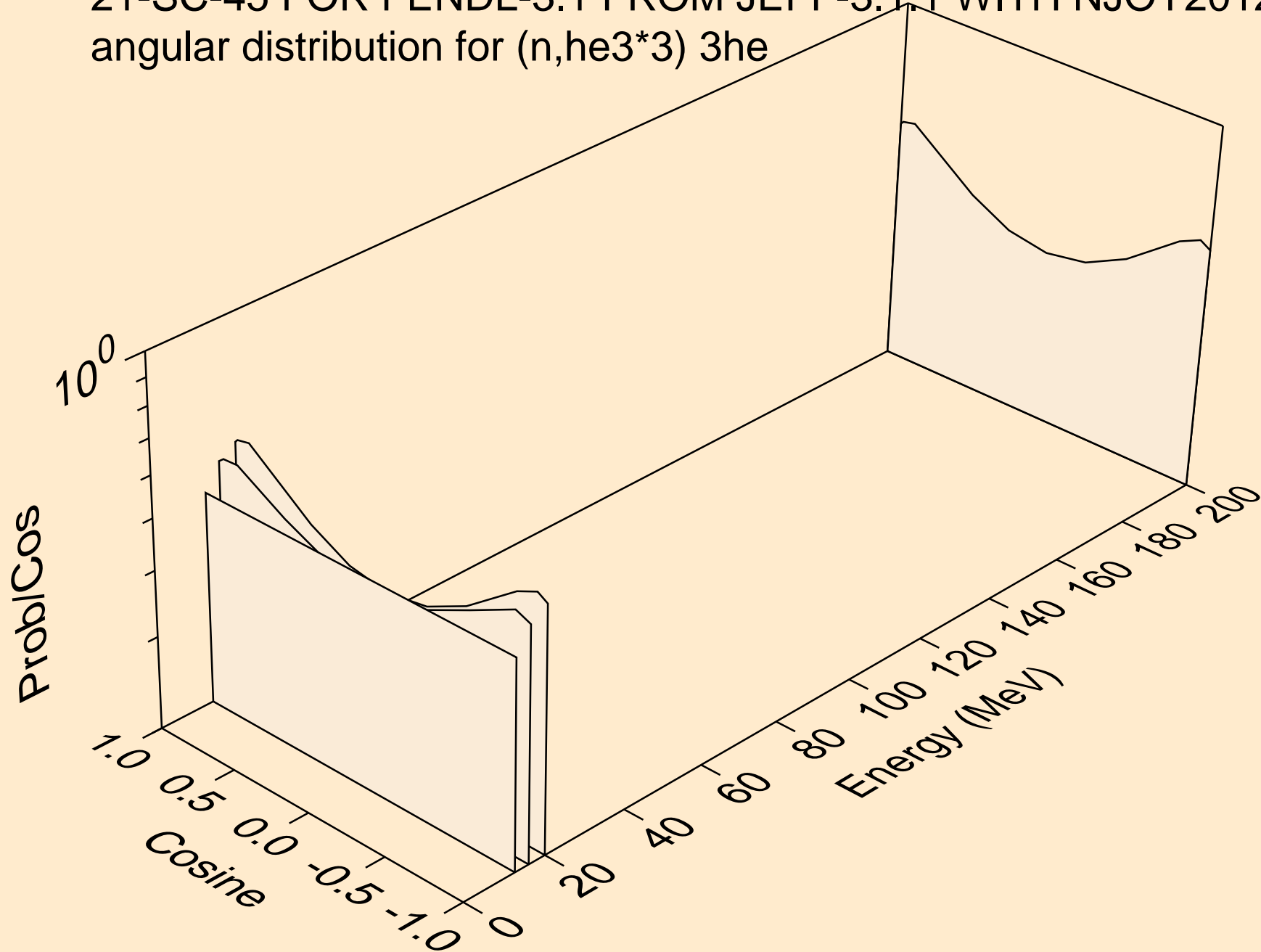

21-SC-45 FOR FENDL-3.1 FROM JEFF-3.1.1 WITH NJOY2012.50+  
angular distribution for (n,he3\*4) 3he

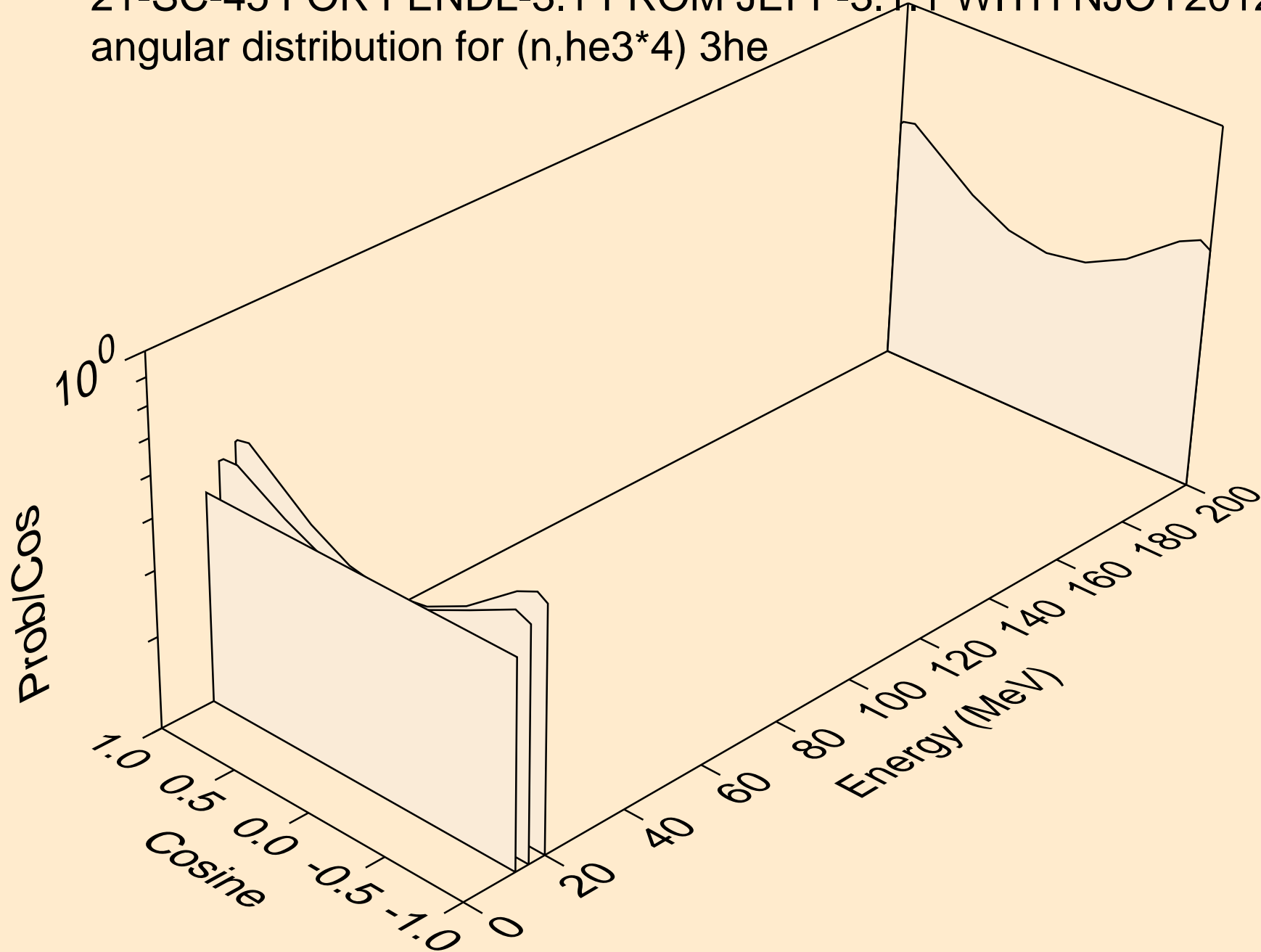

21-SC-45 FOR FENDL-3.1 FROM JEFF-3.1.1 WITH NJOY2012.50+  
angular distribution for (n,he3\*5) 3he

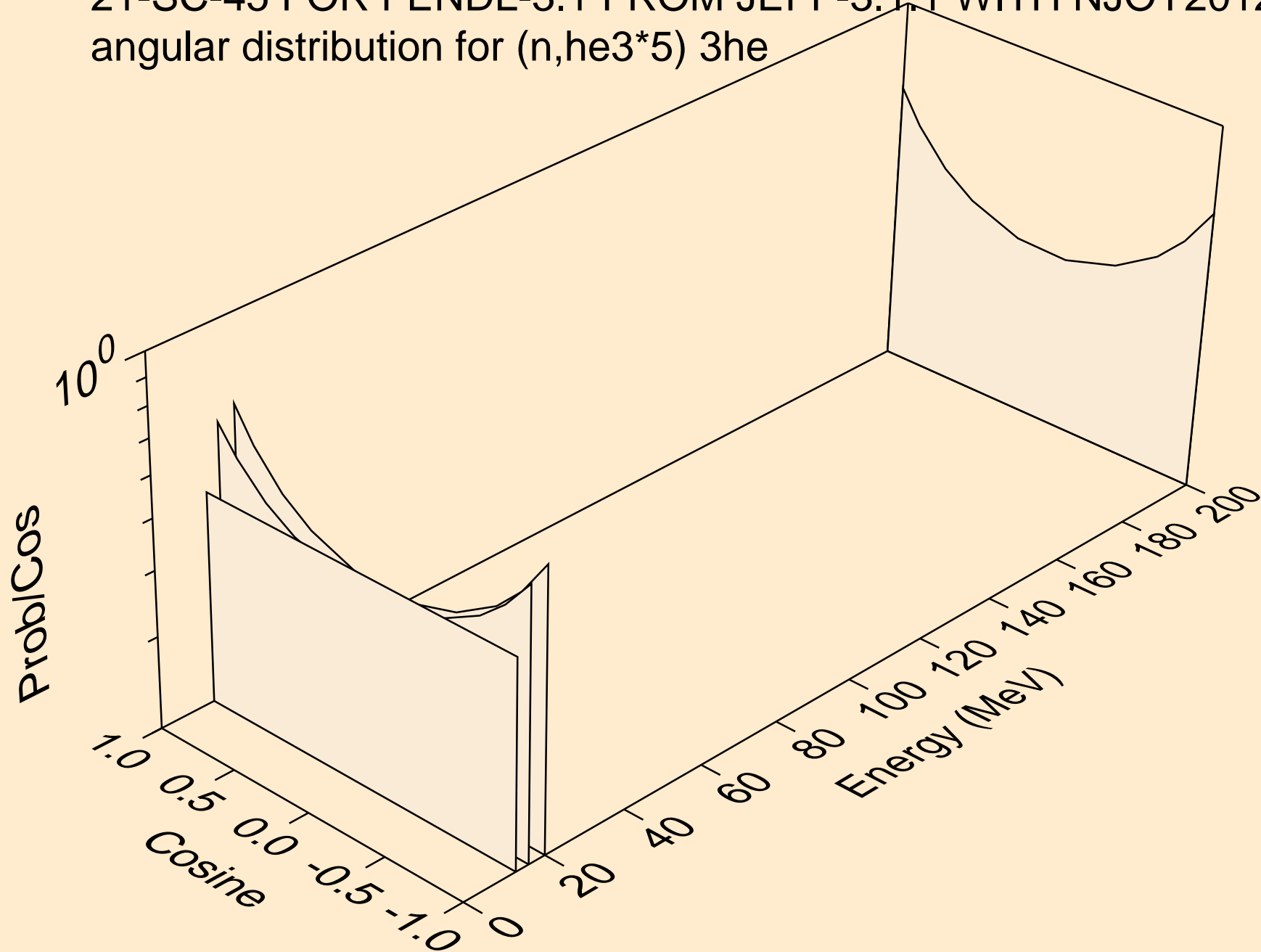

21-SC-45 FOR FENDL-3.1 FROM JEFF-3.1.1 WITH NJOY2012.50+  
he3s from (n,he3\*c)

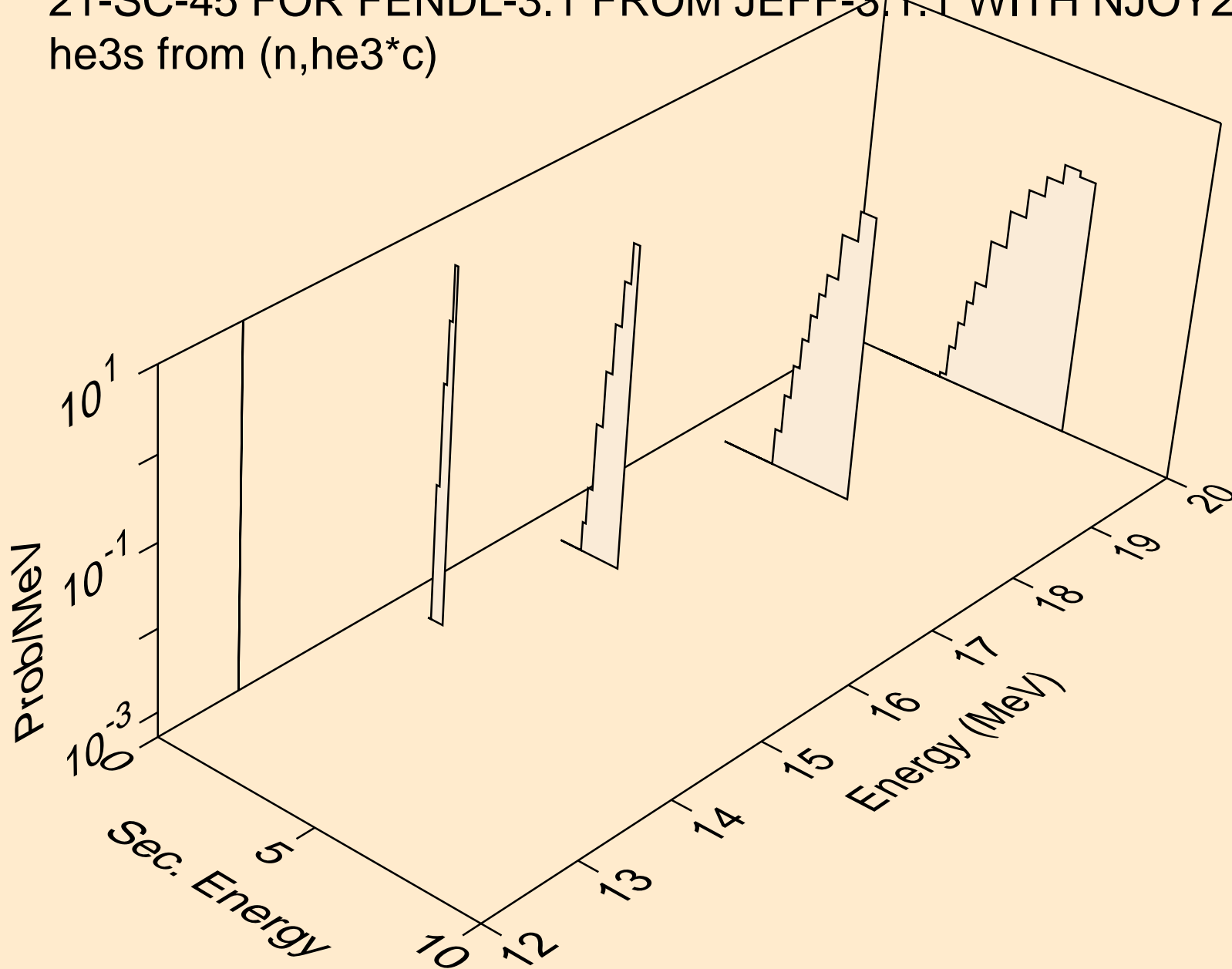

21-SC-45 FOR FENDL-3.1 FROM JEFF-3.1.1 WITH NJOY2012.50+  
alphas from (n,x)

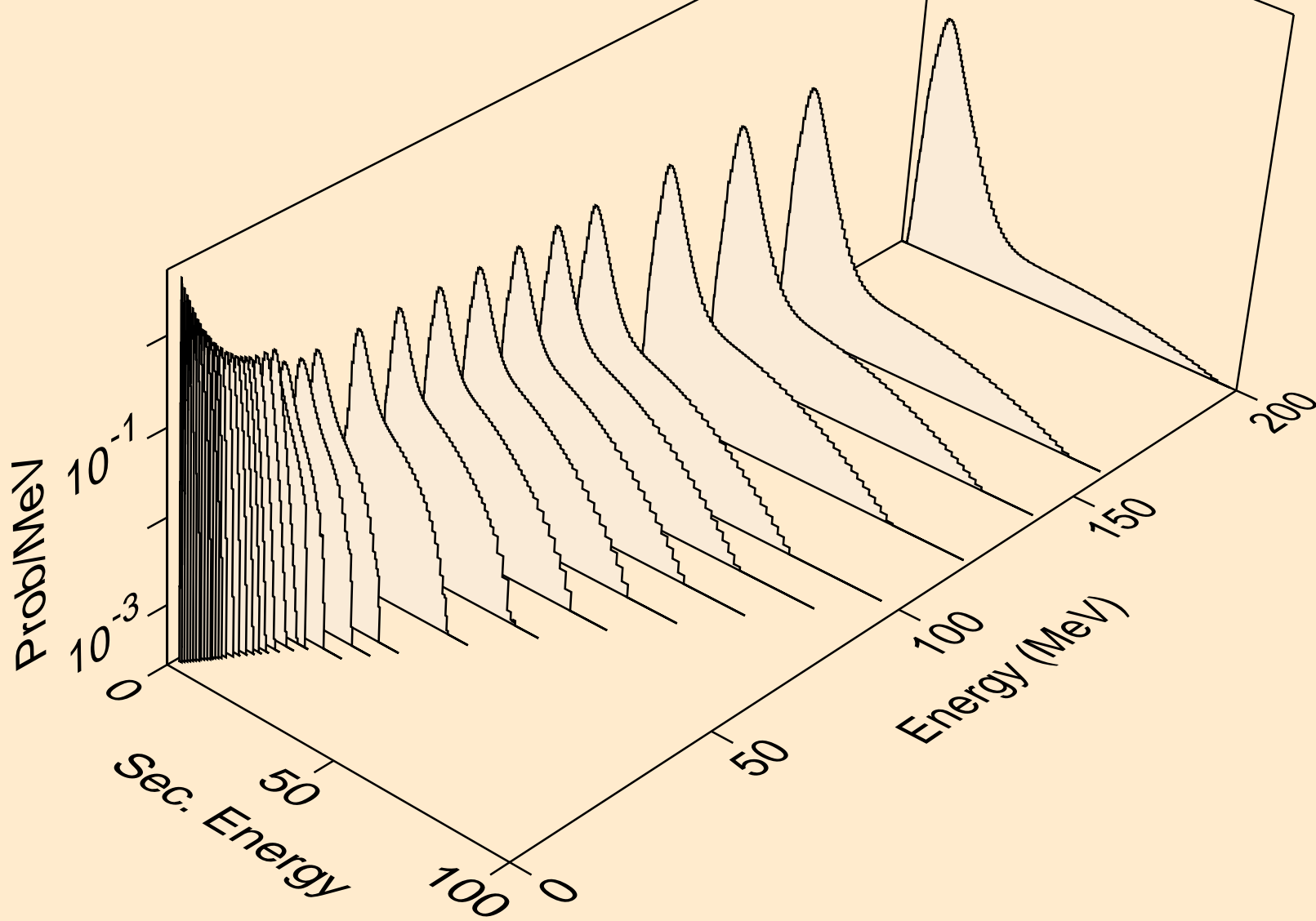

21-SC-45 FOR FENDL-3.1 FROM JEFF-3.1.1 WITH NJOY2012.50+  
alphas from (n,n\*)a

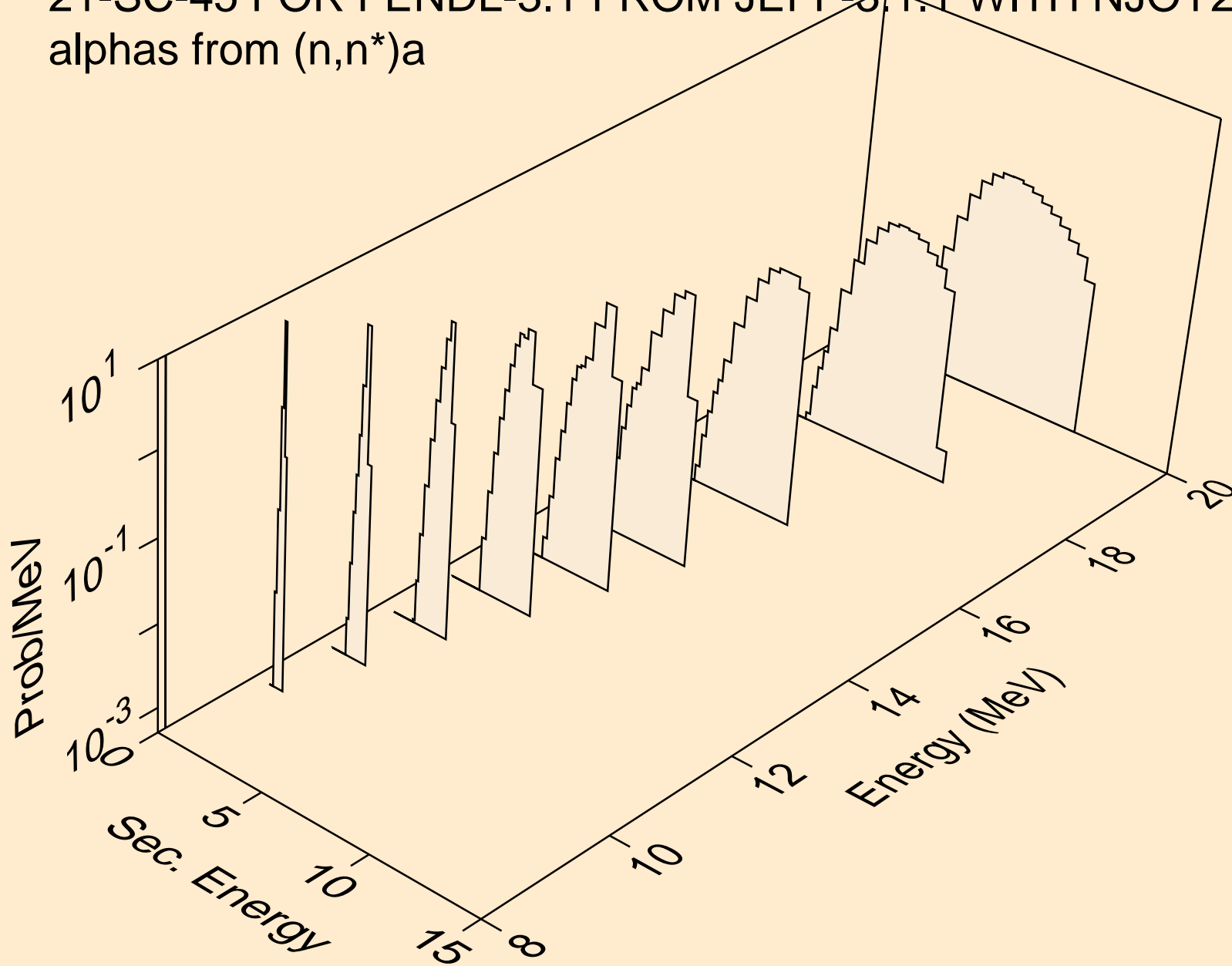

21-SC-45 FOR FENDL-3.1 FROM JEFF-3.1.1 WITH NJOY2012.50+  
alphas from (n,2a)

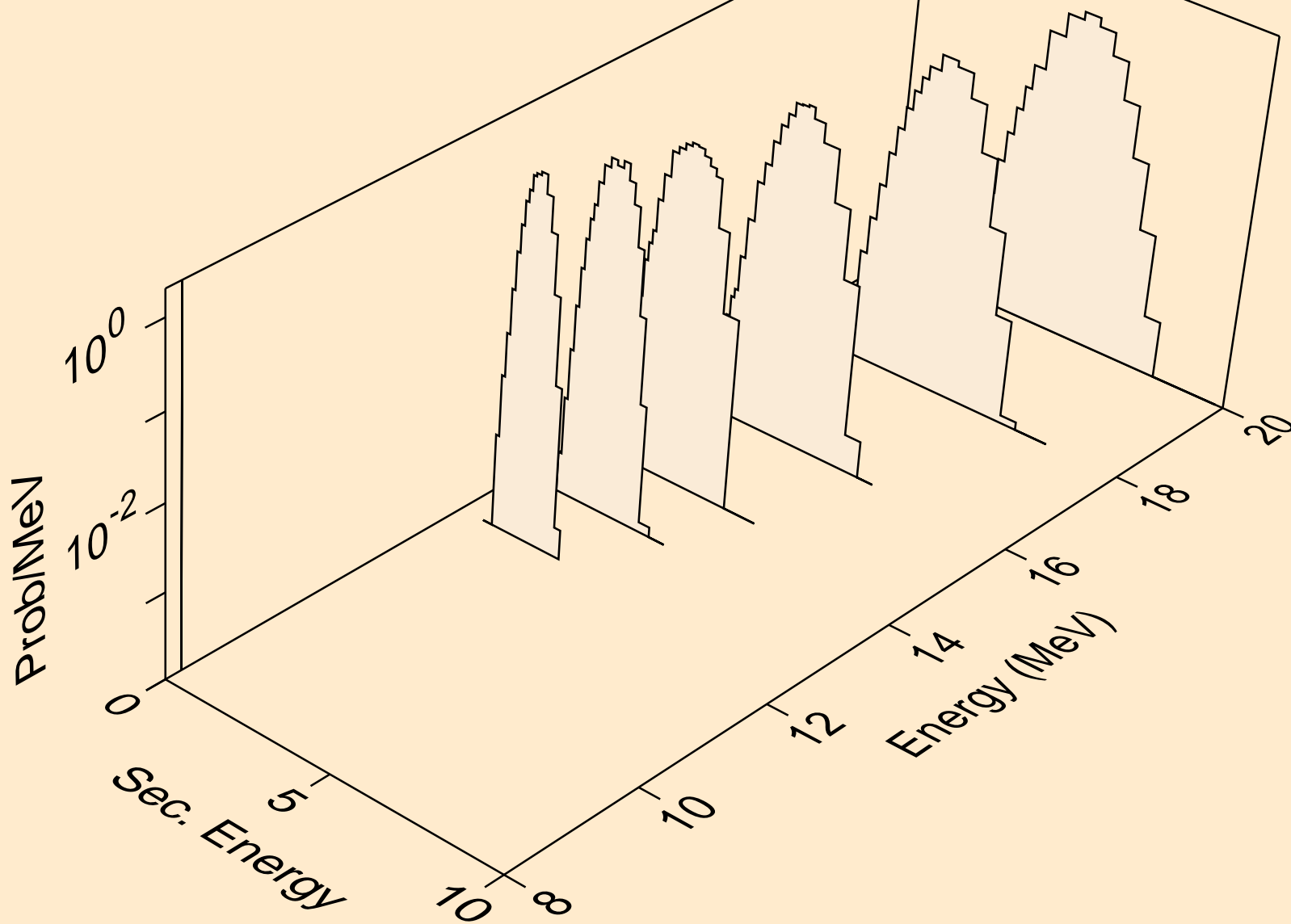

21-SC-45 FOR FENDL-3.1 FROM JEFF-3.1.1 WITH NJOY2012.50+  
alphas from (n,pa)

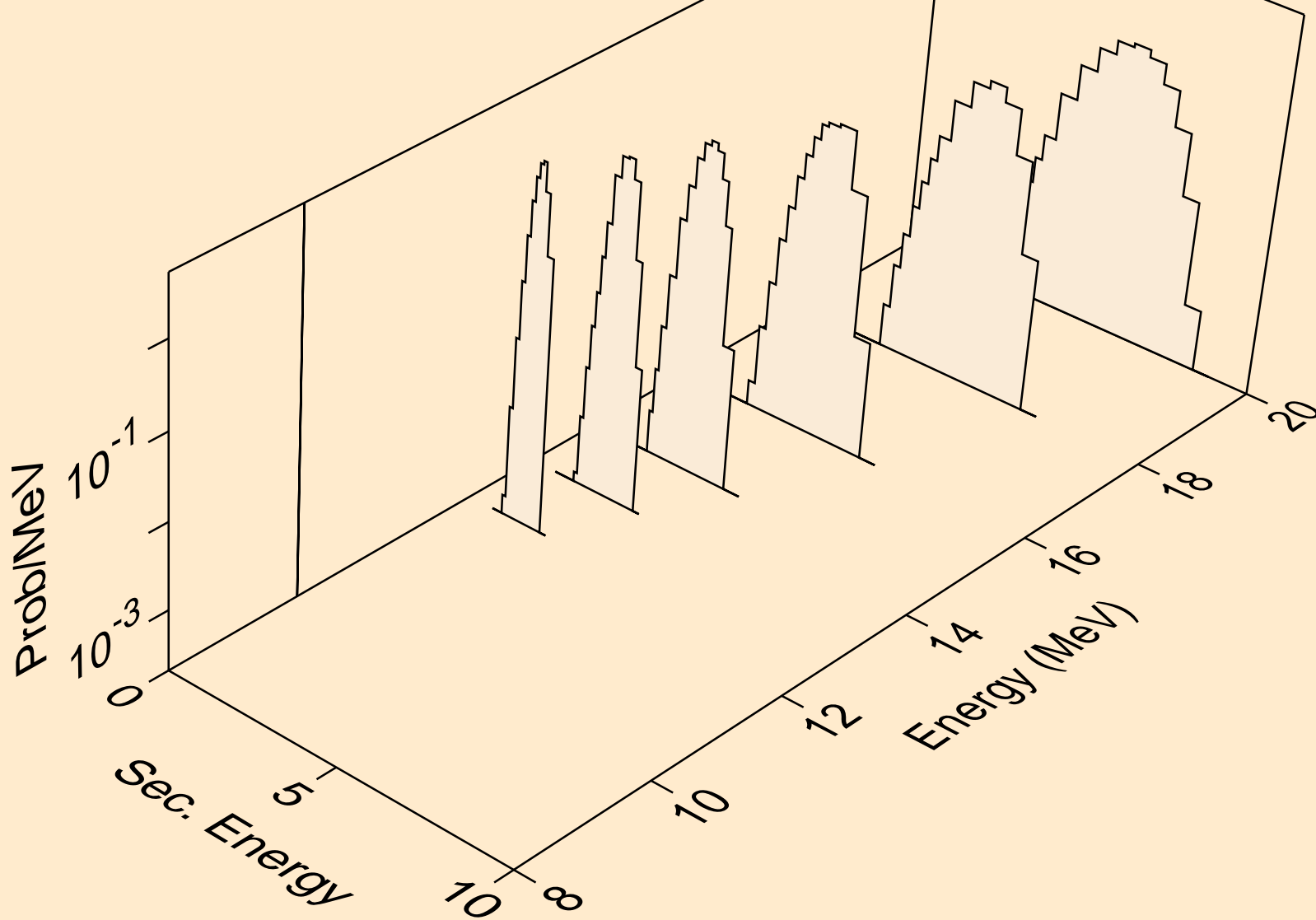



21-SC-45 FOR FENDL-3.1 FROM JEFF-3.1.1 WITH NJOY2012.50+  
alphas from (n,da)

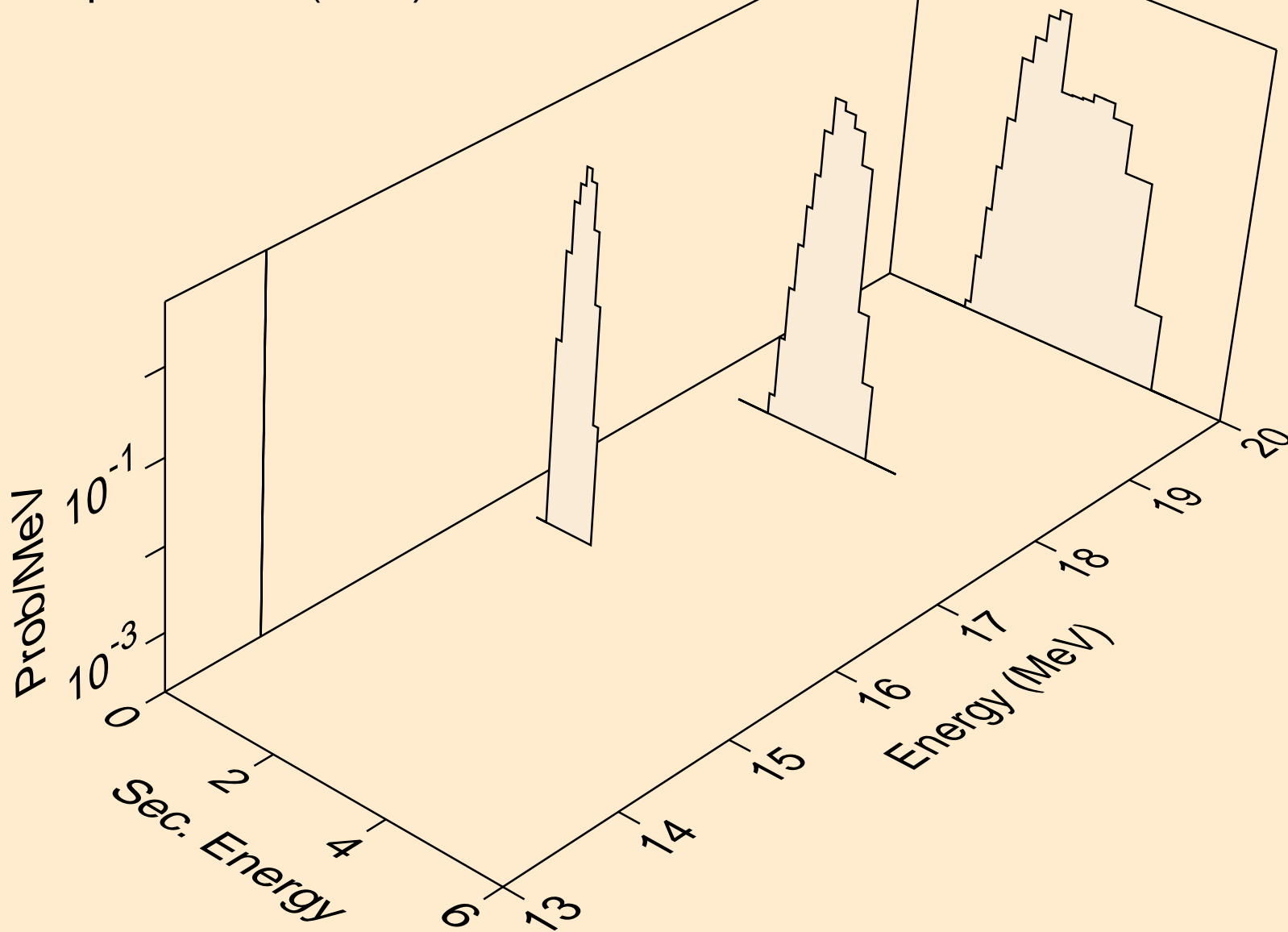

21-SC-45 FOR FENDL-3.1 FROM JEFF-3.1.1 WITH NJOY2012.50+  
angular distribution for (n,a\*0) alpha

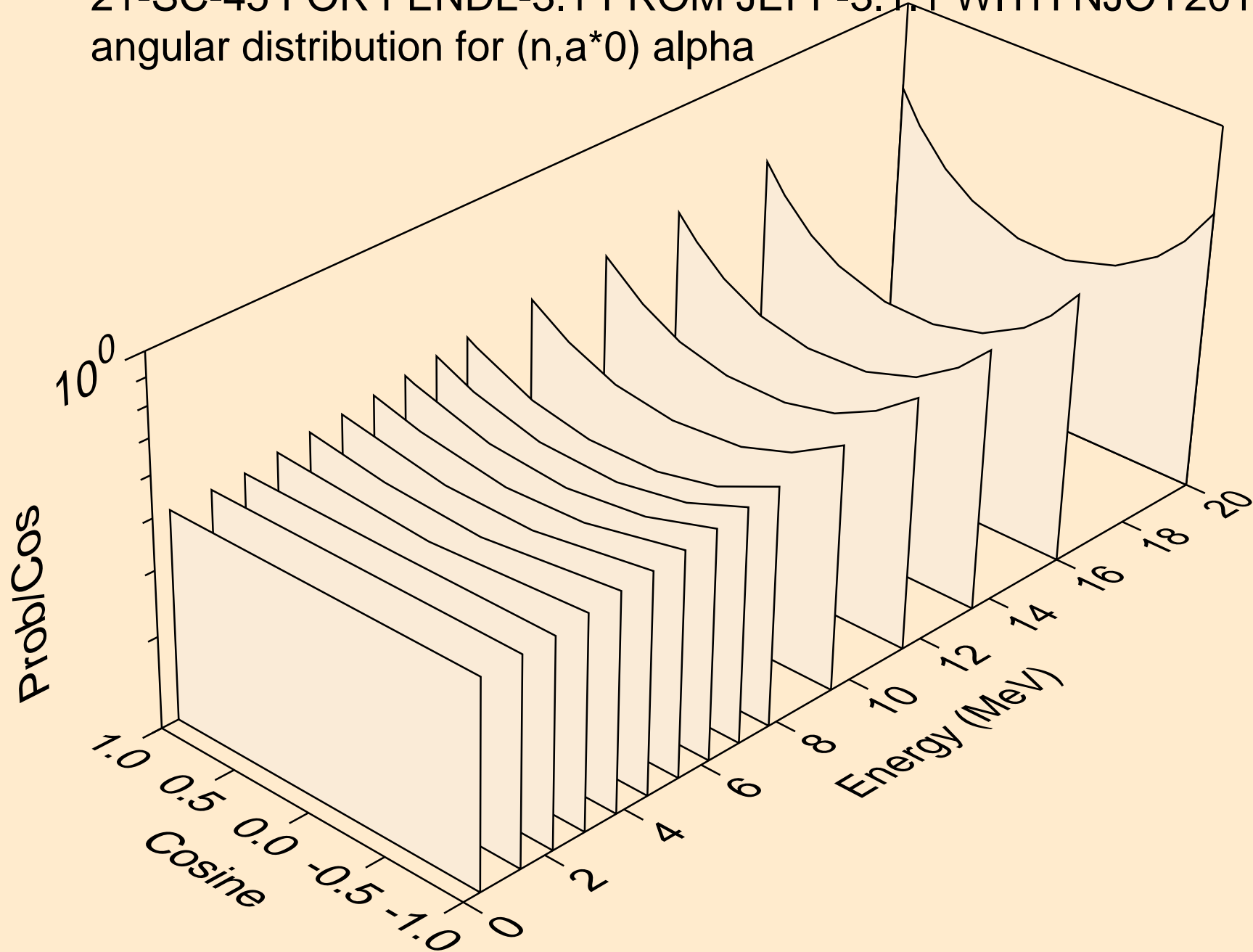

21-SC-45 FOR FENDL-3.1 FROM JEFF-3.1.1 WITH NJOY2012.50+  
angular distribution for (n,a\*1) alpha

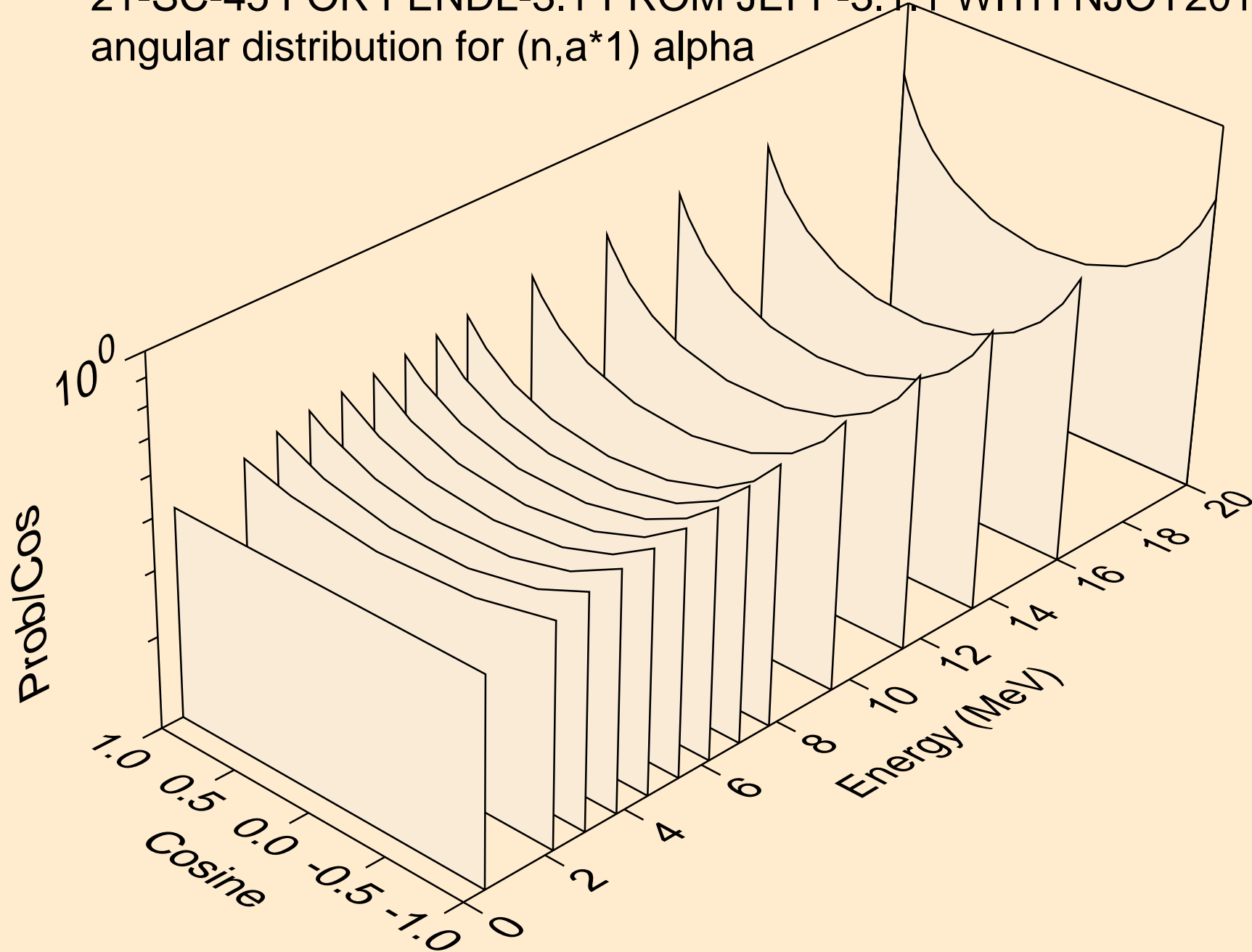

21-SC-45 FOR FENDL-3.1 FROM JEFF-3.1.1 WITH NJOY2012.50+  
angular distribution for (n,a\*2) alpha

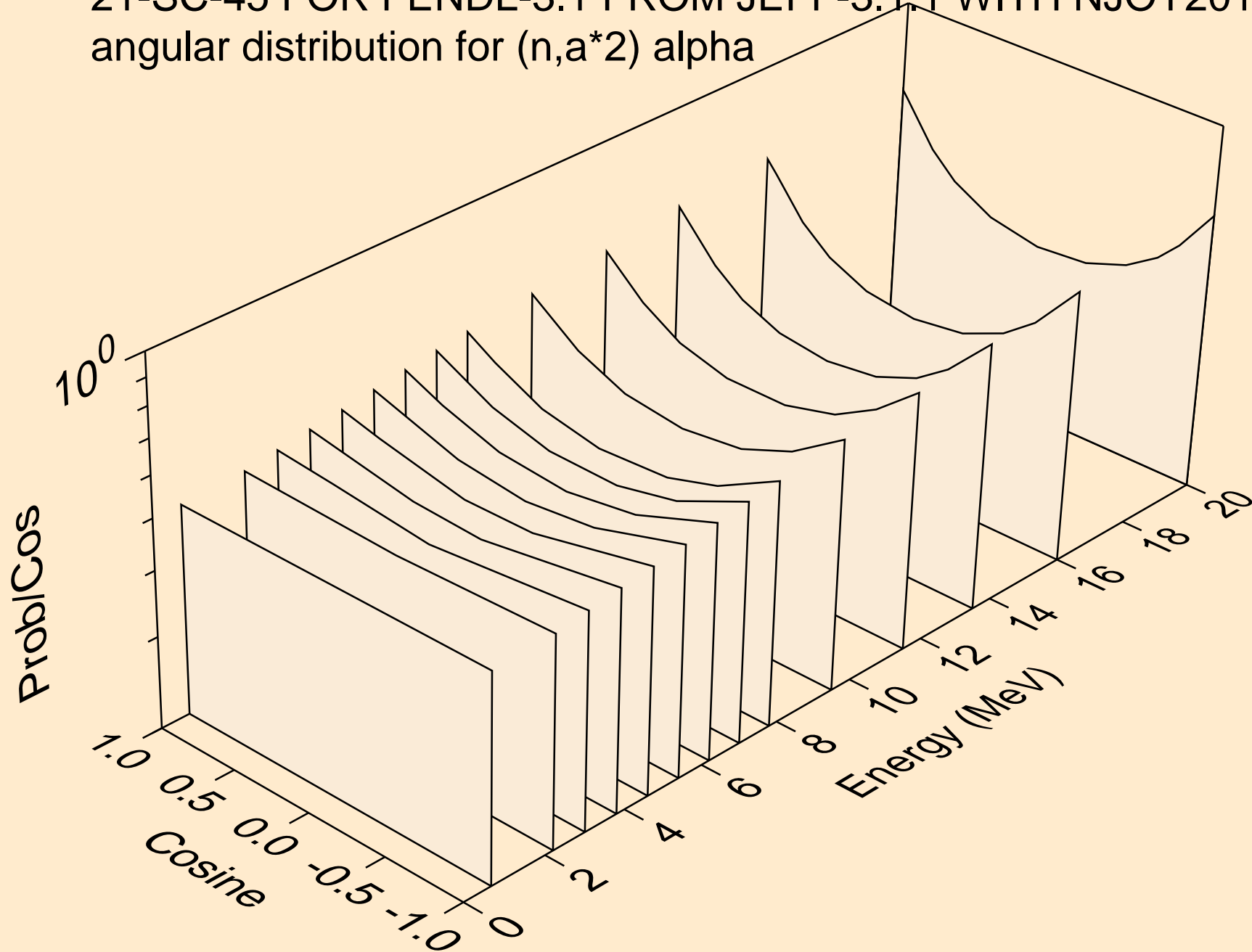

21-SC-45 FOR FENDL-3.1 FROM JEFF-3.1.1 WITH NJOY2012.50+  
angular distribution for (n,a\*3) alpha

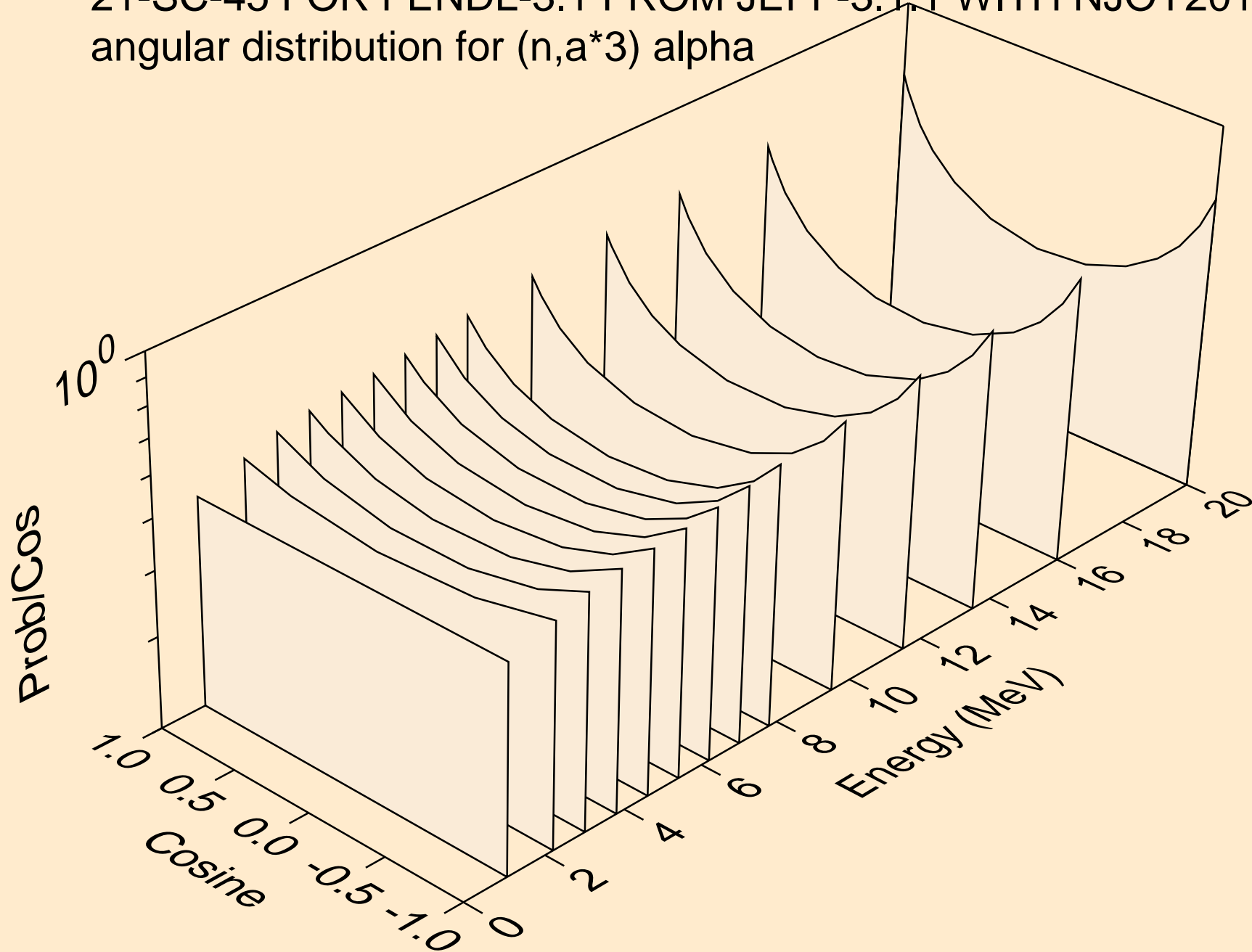

21-SC-45 FOR FENDL-3.1 FROM JEFF-3.1.1 WITH NJOY2012.50+  
angular distribution for (n,a\*4) alpha

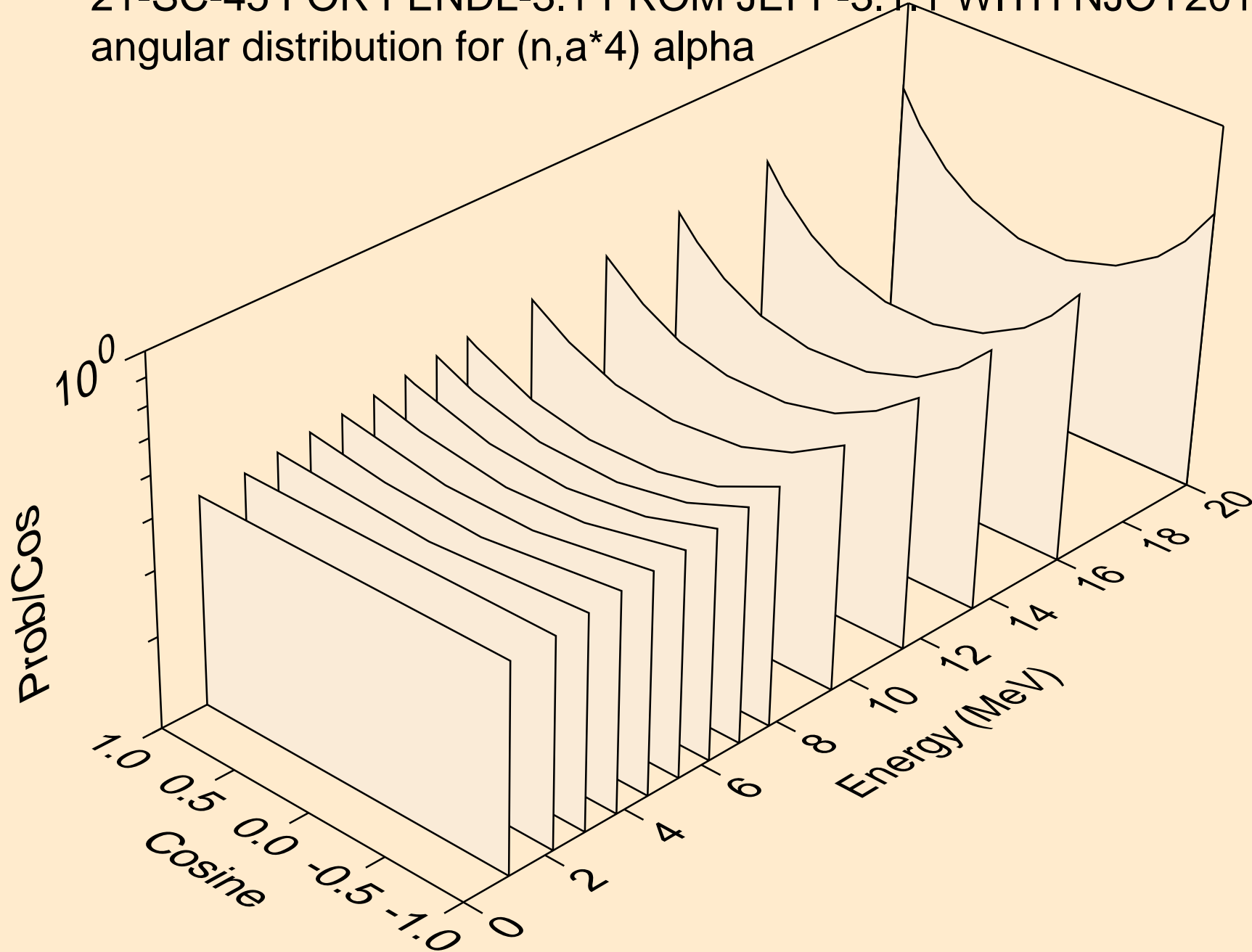

21-SC-45 FOR FENDL-3.1 FROM JEFF-3.1.1 WITH NJOY2012.50+  
angular distribution for (n,a\*5) alpha

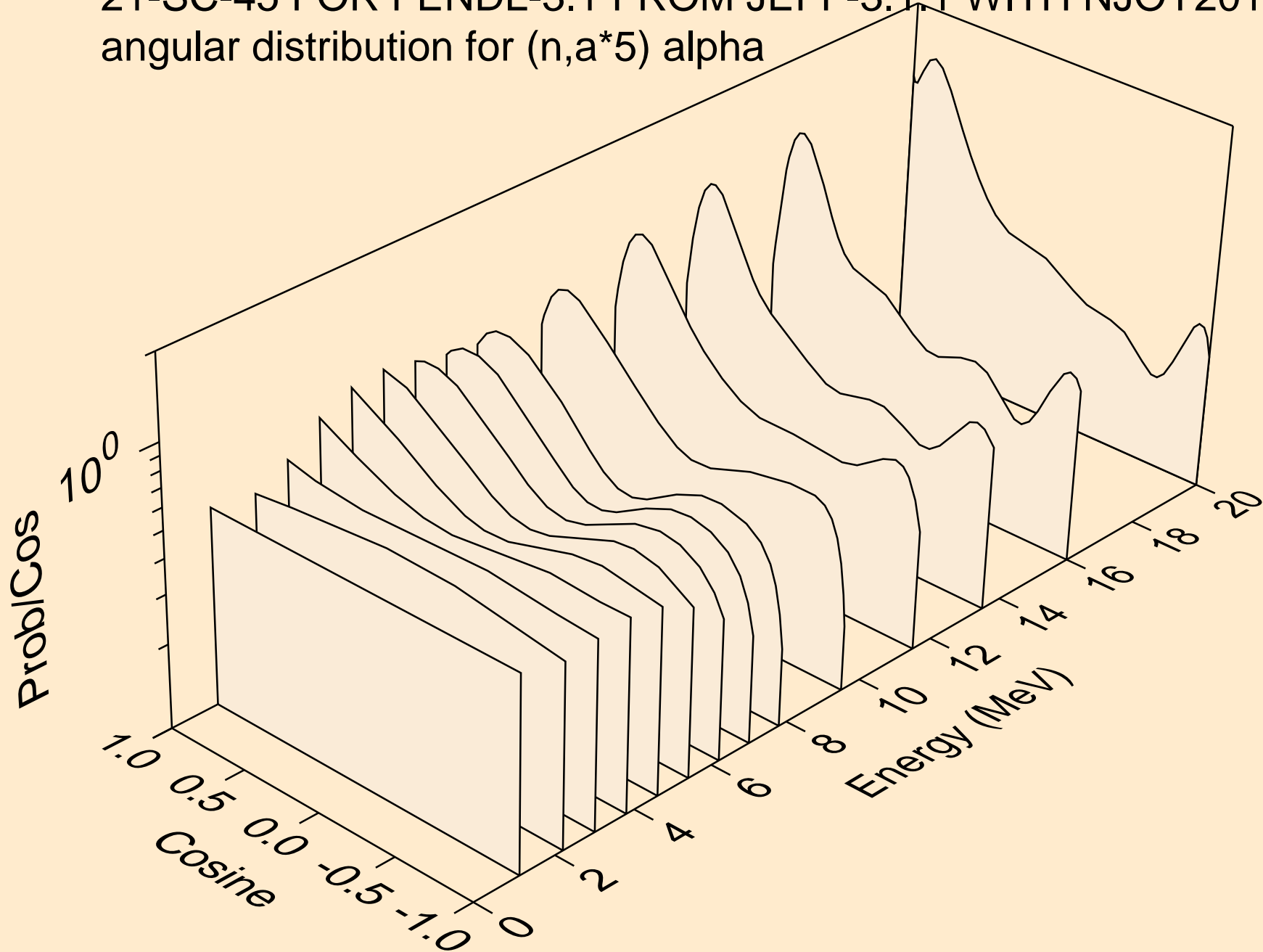

21-SC-45 FOR FENDL-3.1 FROM JEFF-3.1.1 WITH NJOY2012.50+  
angular distribution for (n,a\*6) alpha

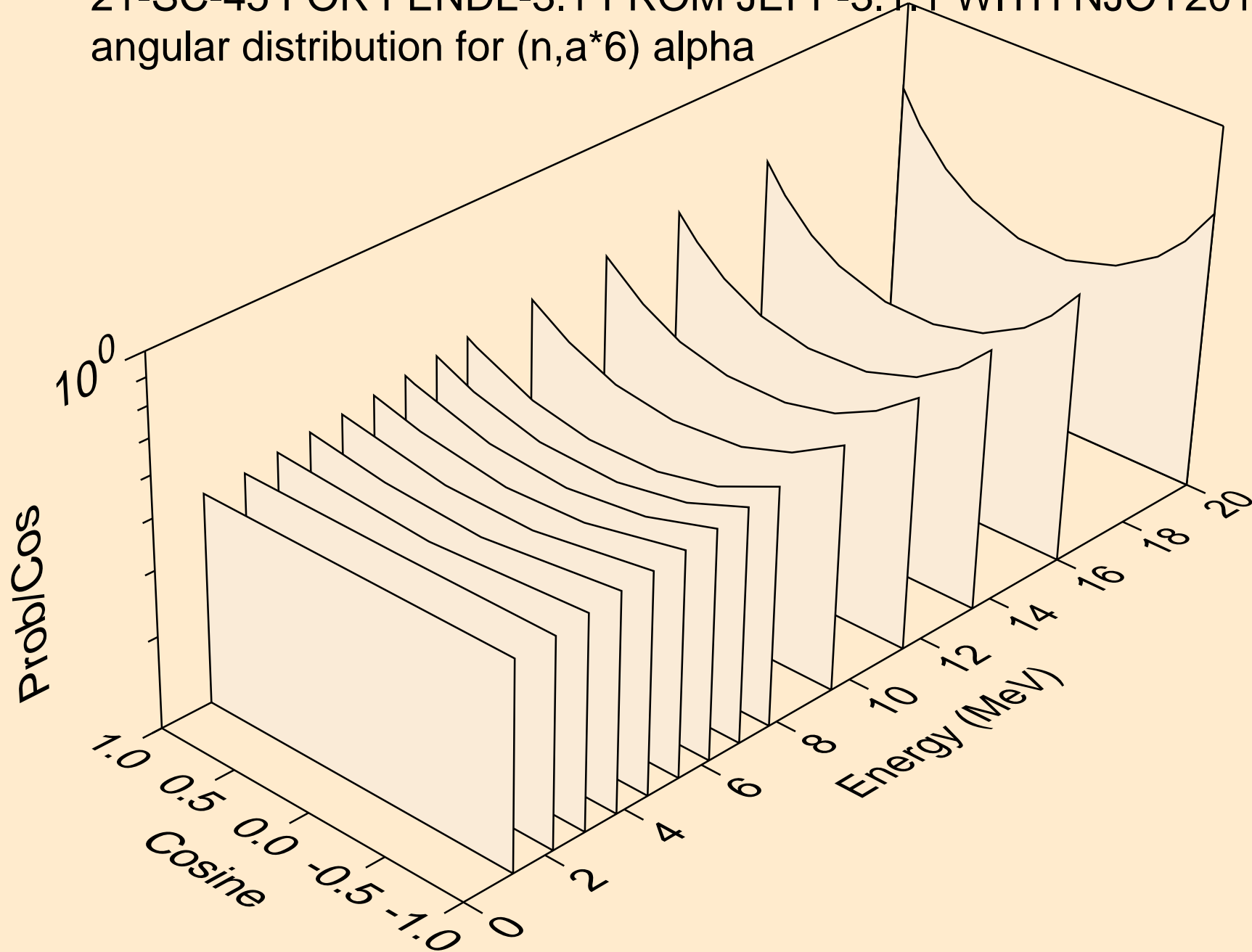



21-SC-45 FOR FENDL-3.1 FROM JEFF-3.1.1 WITH NJOY2012.50+  
angular distribution for (n,a\*7) alpha

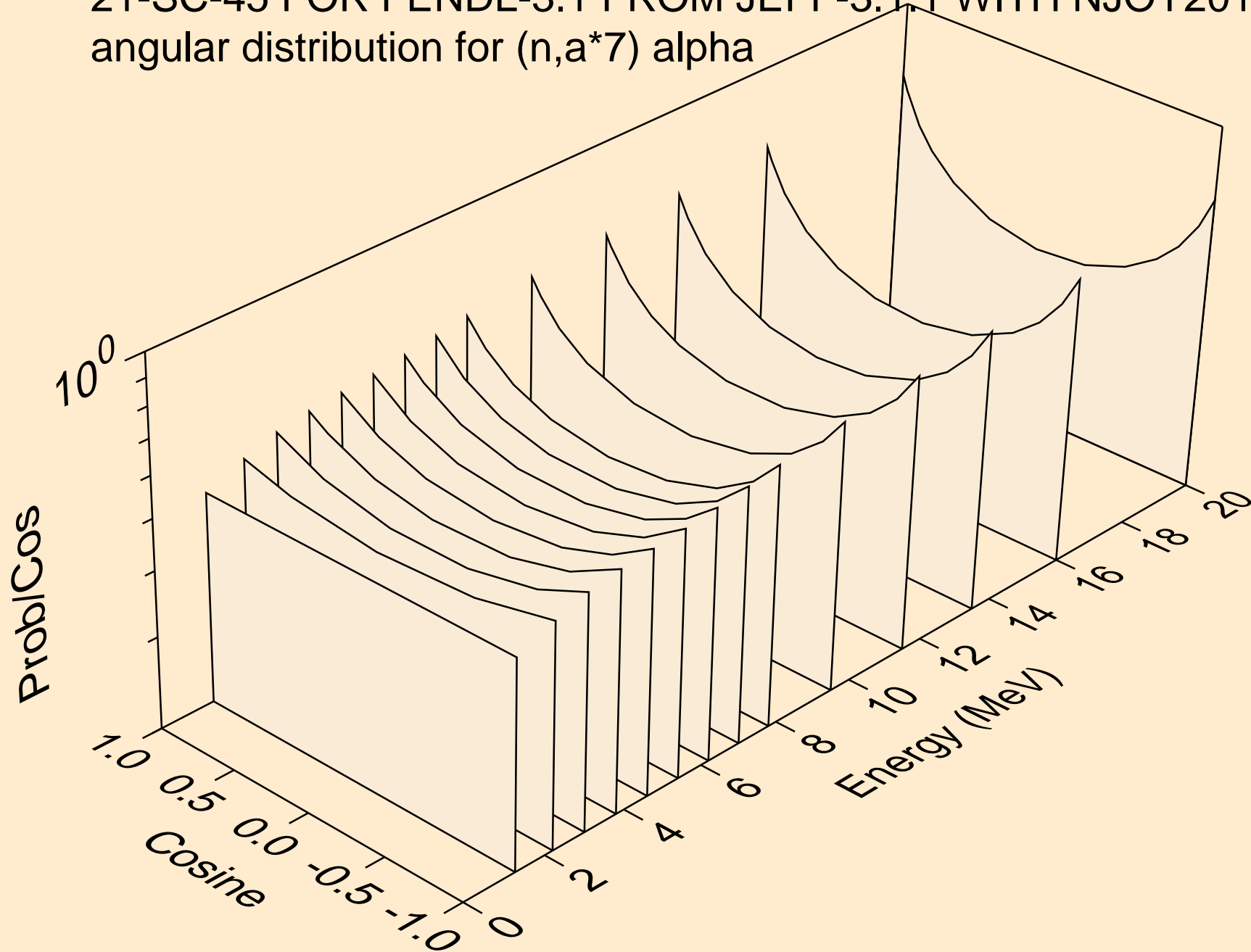

21-SC-45 FOR FENDL-3.1 FROM JEFF-3.1.1 WITH NJOY2012.50+  
angular distribution for (n,a\*8) alpha

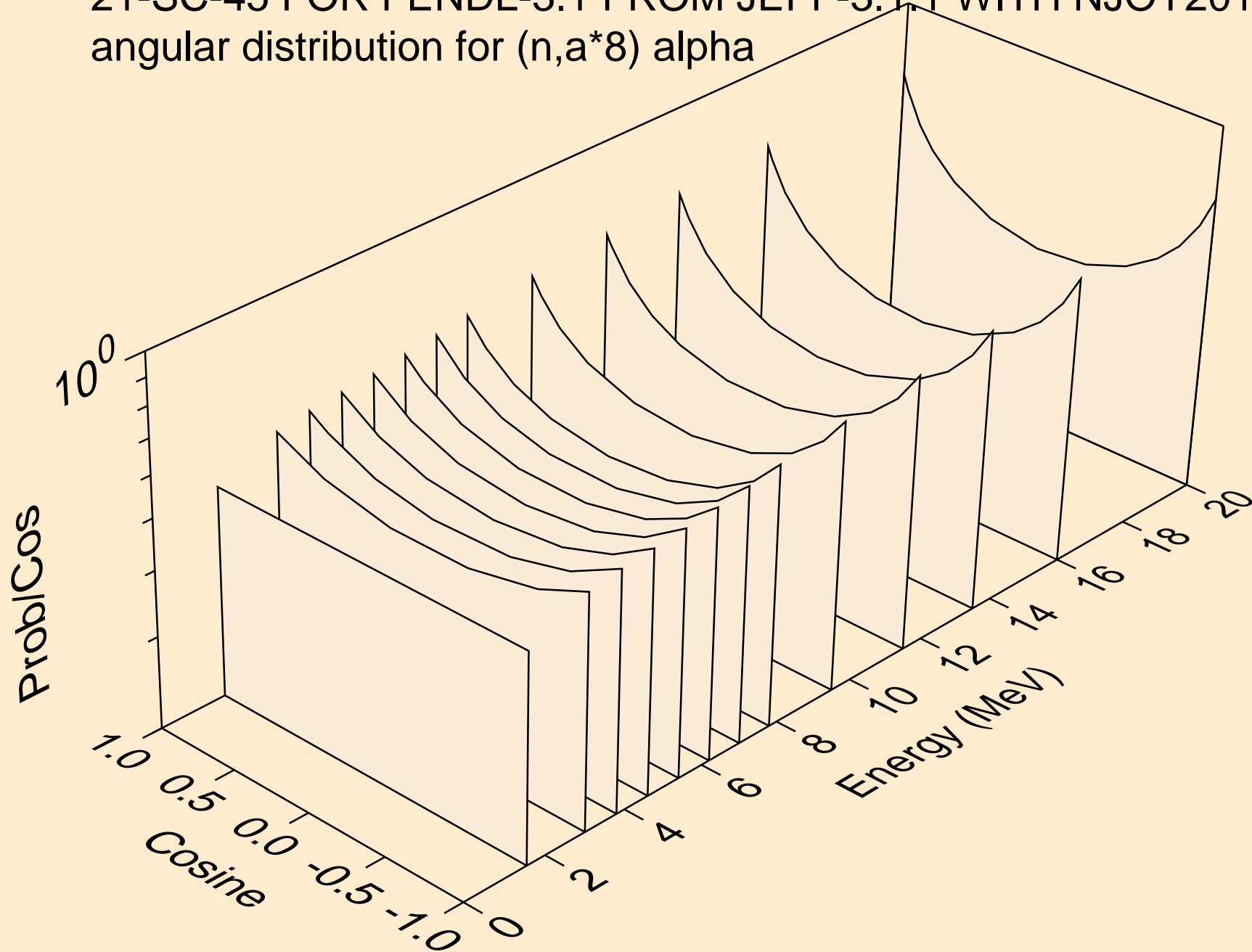

21-SC-45 FOR FENDL-3.1 FROM JEFF-3.1.1 WITH NJOY2012.50+  
angular distribution for (n,a\*9) alpha

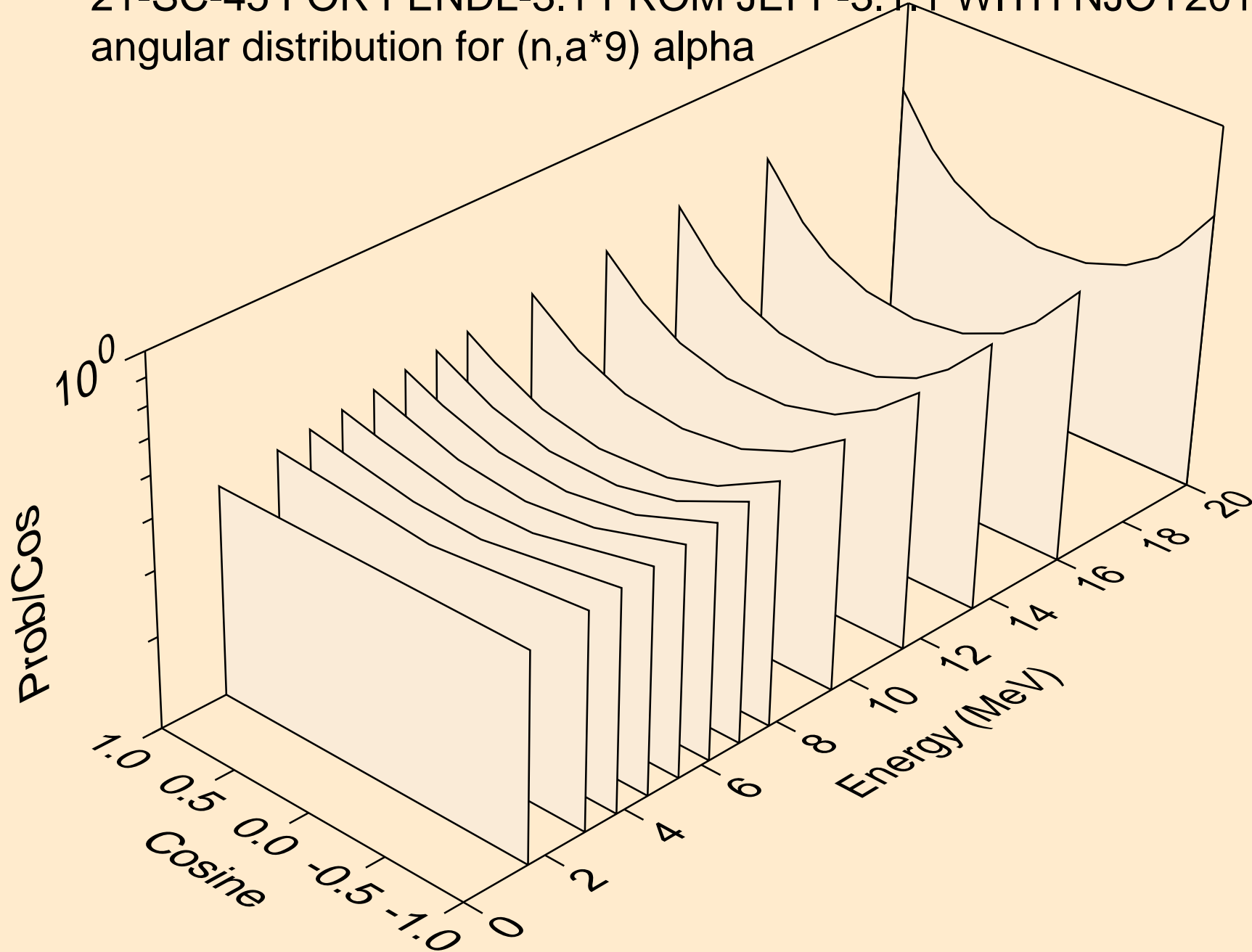

21-SC-45 FOR FENDL-3.1 FROM JEFF-3.1.1 WITH NJOY2012.50+  
angular distribution for (n,a\*10) alpha

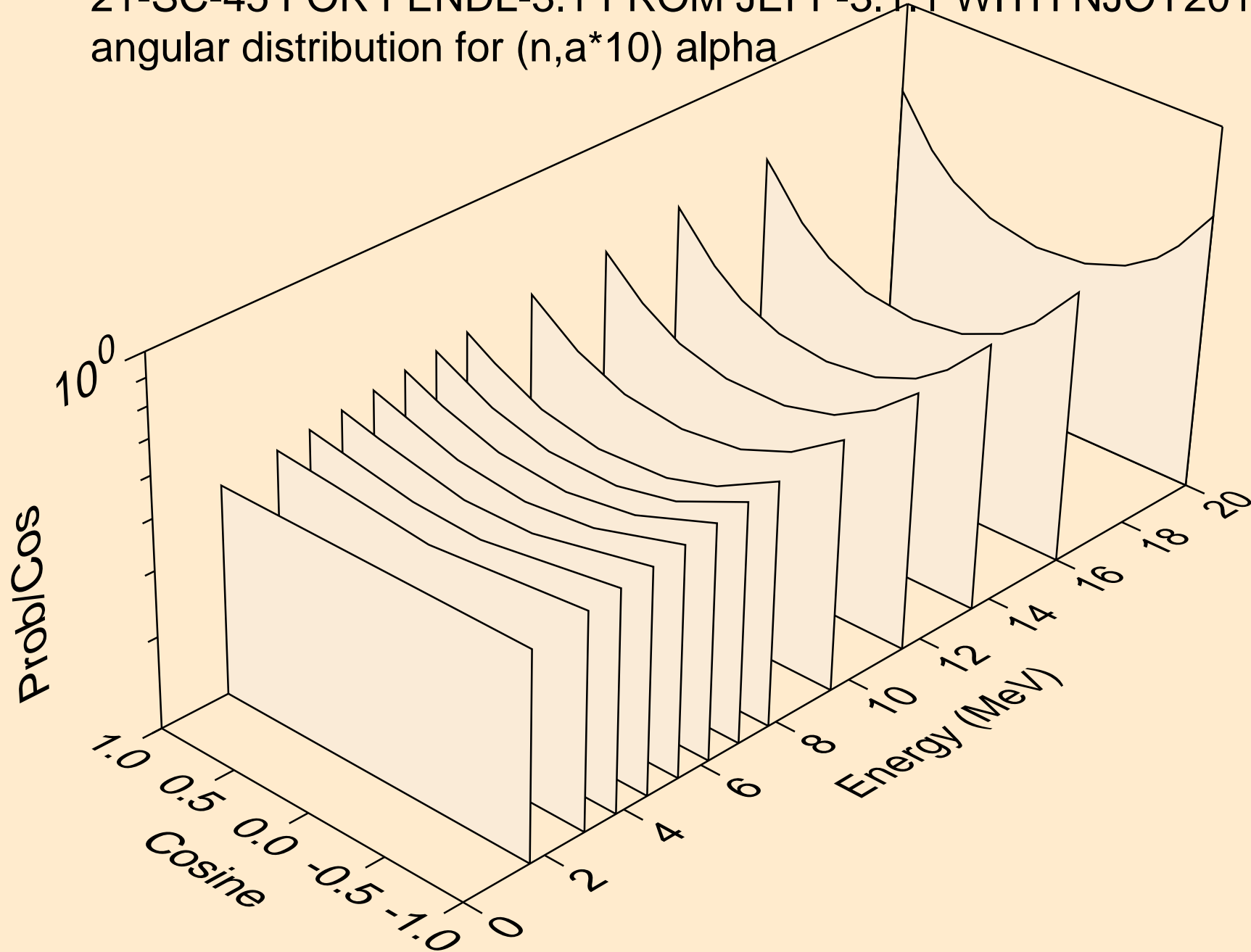

21-SC-45 FOR FENDL-3.1 FROM JEFF-3.1.1 WITH NJOY2012.50+  
alphas from (n,a\*c)

