

23-V-51 FOR FENDL-3.1 FROM FENDL-3.1 WITH NJOY2012.50+ C
Principal cross sections

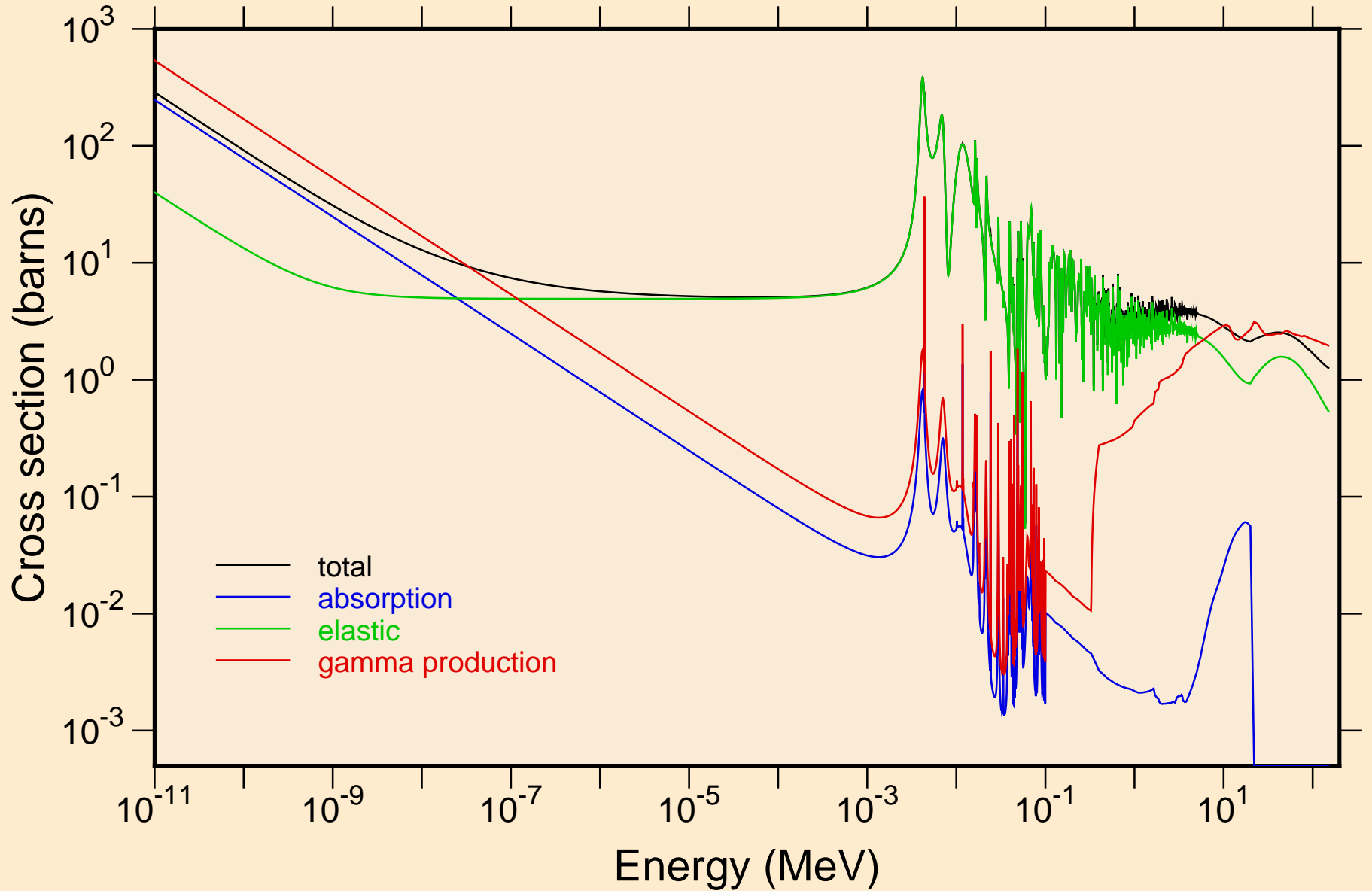

23-V-51 FOR FENDL-3.1 FROM FENDL-3.1 WITH NJOY2012.50+ C
resonance total cross section

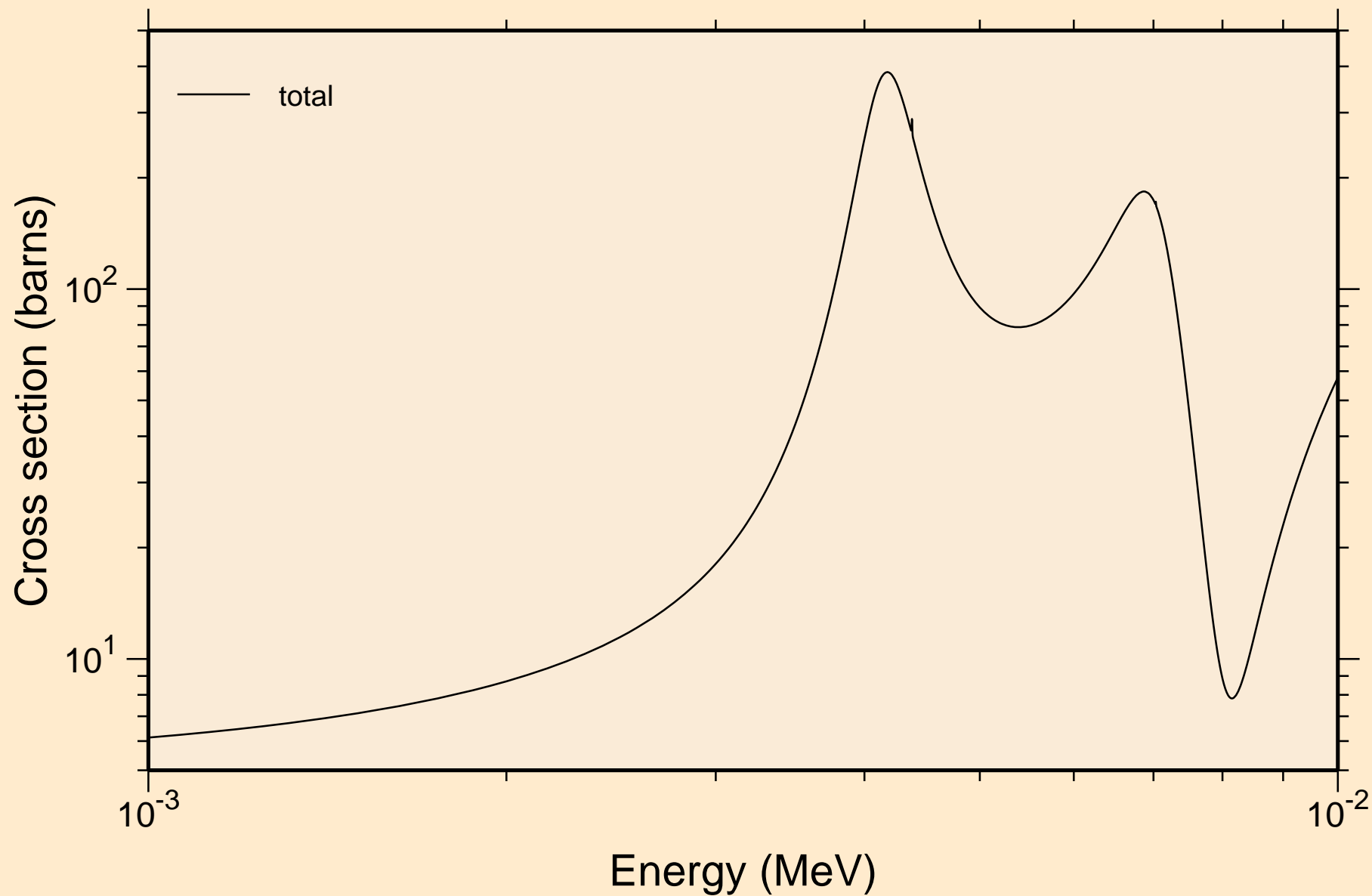

23-V-51 FOR FENDL-3.1 FROM FENDL-3.1 WITH NJOY2012.50+ C
resonance total cross section

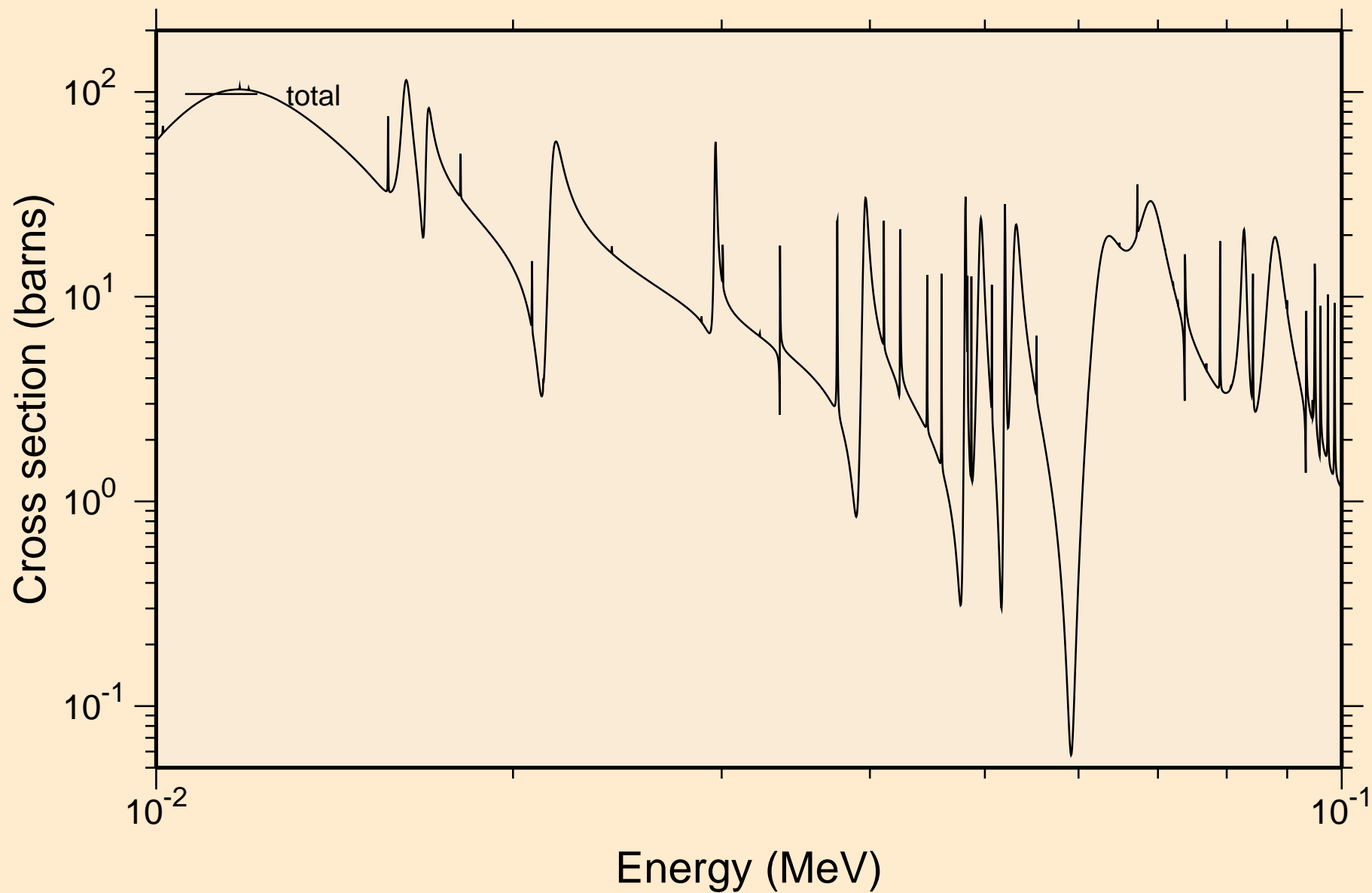

23-V-51 FOR FENDL-3.1 FROM FENDL-3.1 WITH NJOY2012.50+ C
resonance total cross section

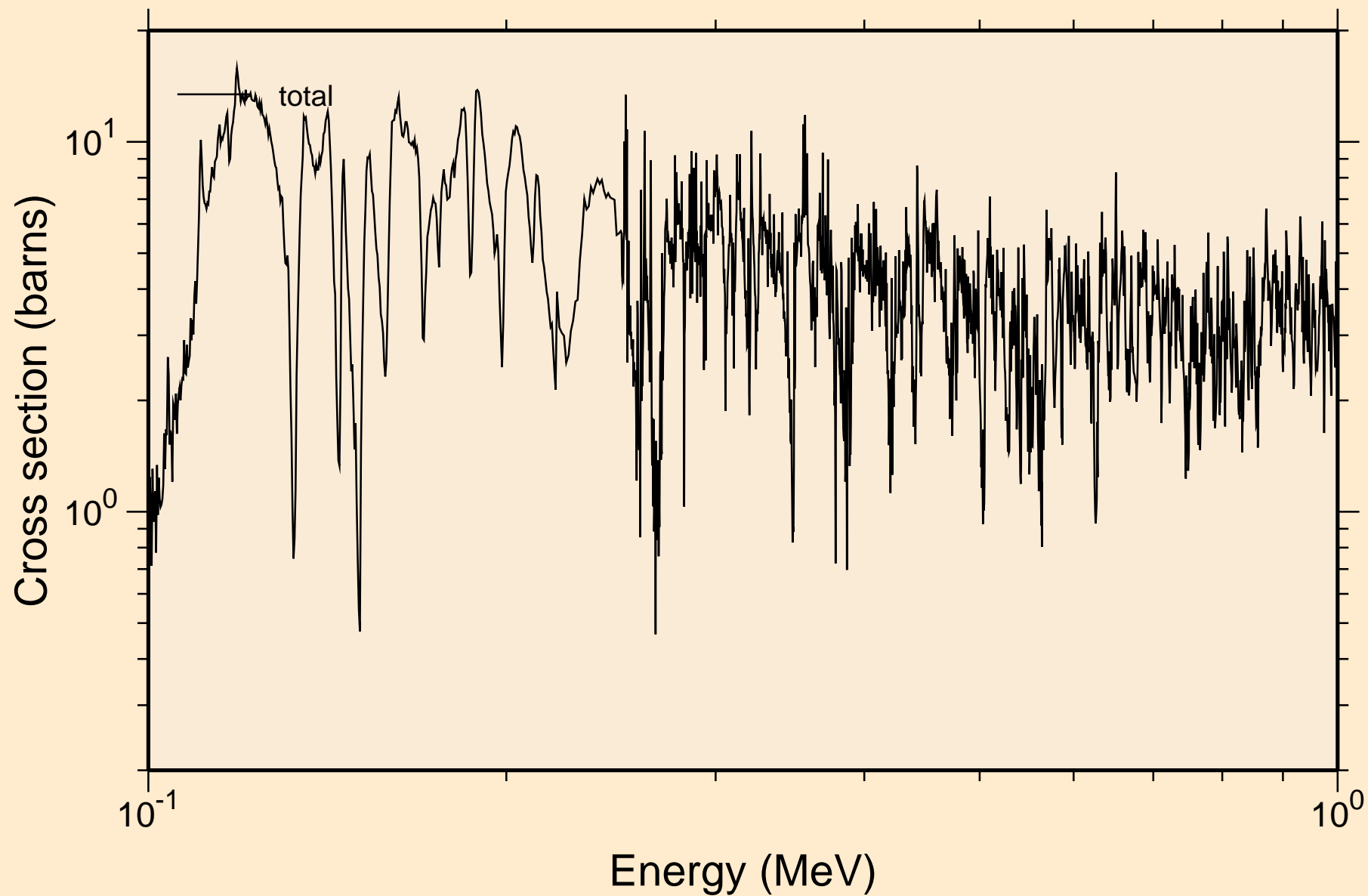

23-V-51 FOR FENDL-3.1 FROM FENDL-3.1 WITH NJOY2012.50+ C
resonance total cross section

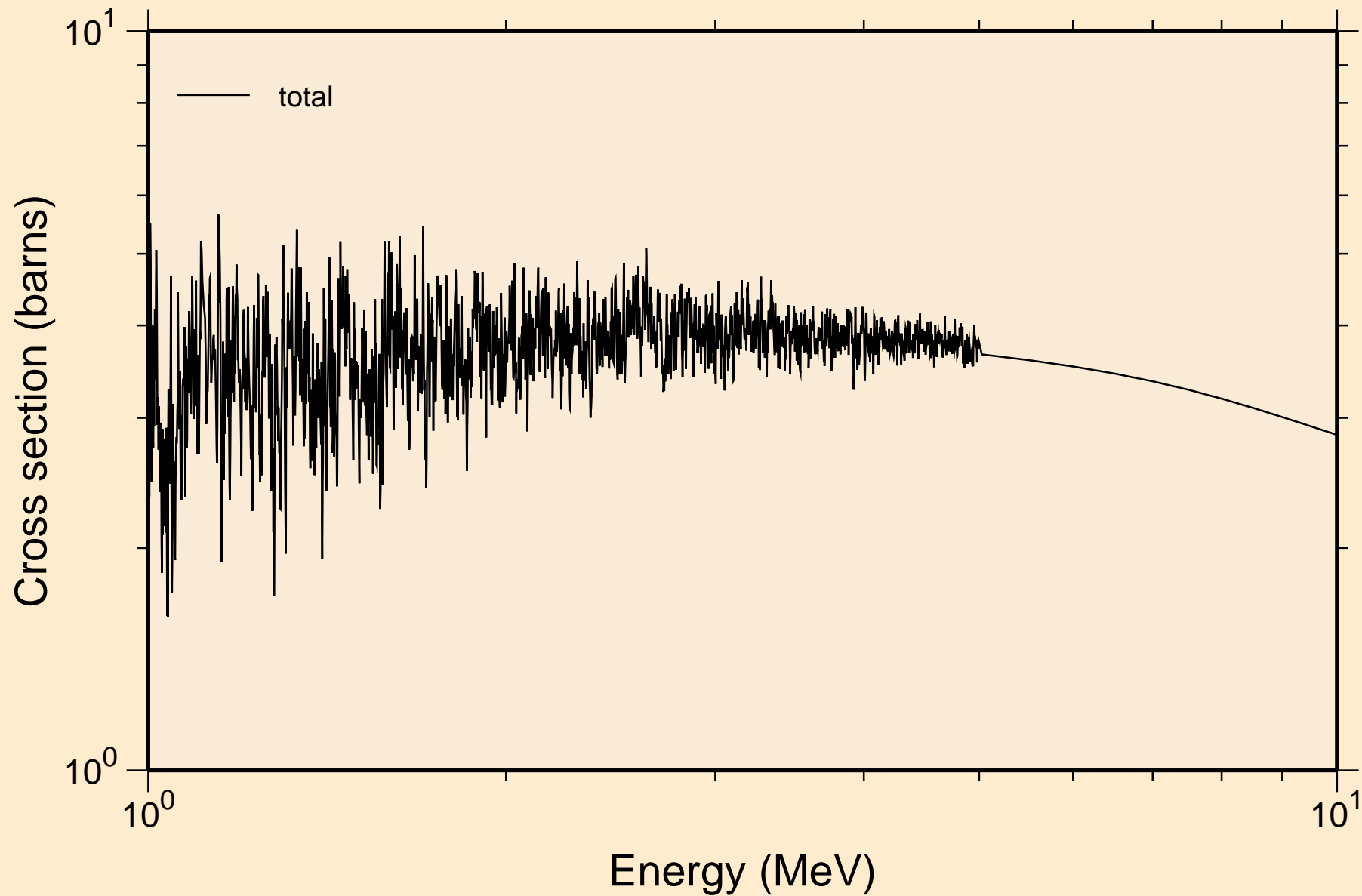

23-V-51 FOR FENDL-3.1 FROM FENDL-3.1 WITH NJOY2012.50+ C
resonance absorption cross sections

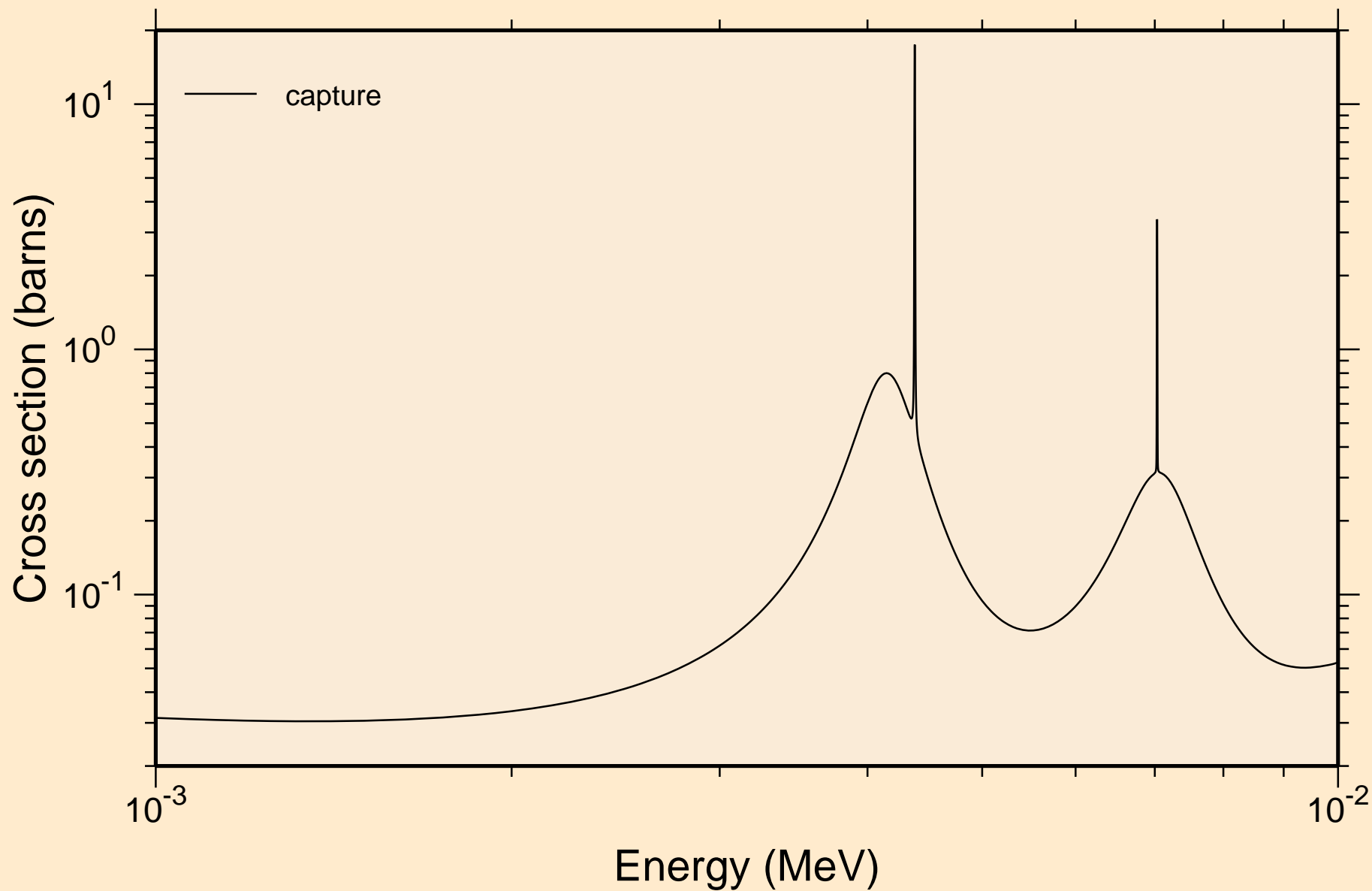

23-V-51 FOR FENDL-3.1 FROM FENDL-3.1 WITH NJOY2012.50+ C
resonance absorption cross sections

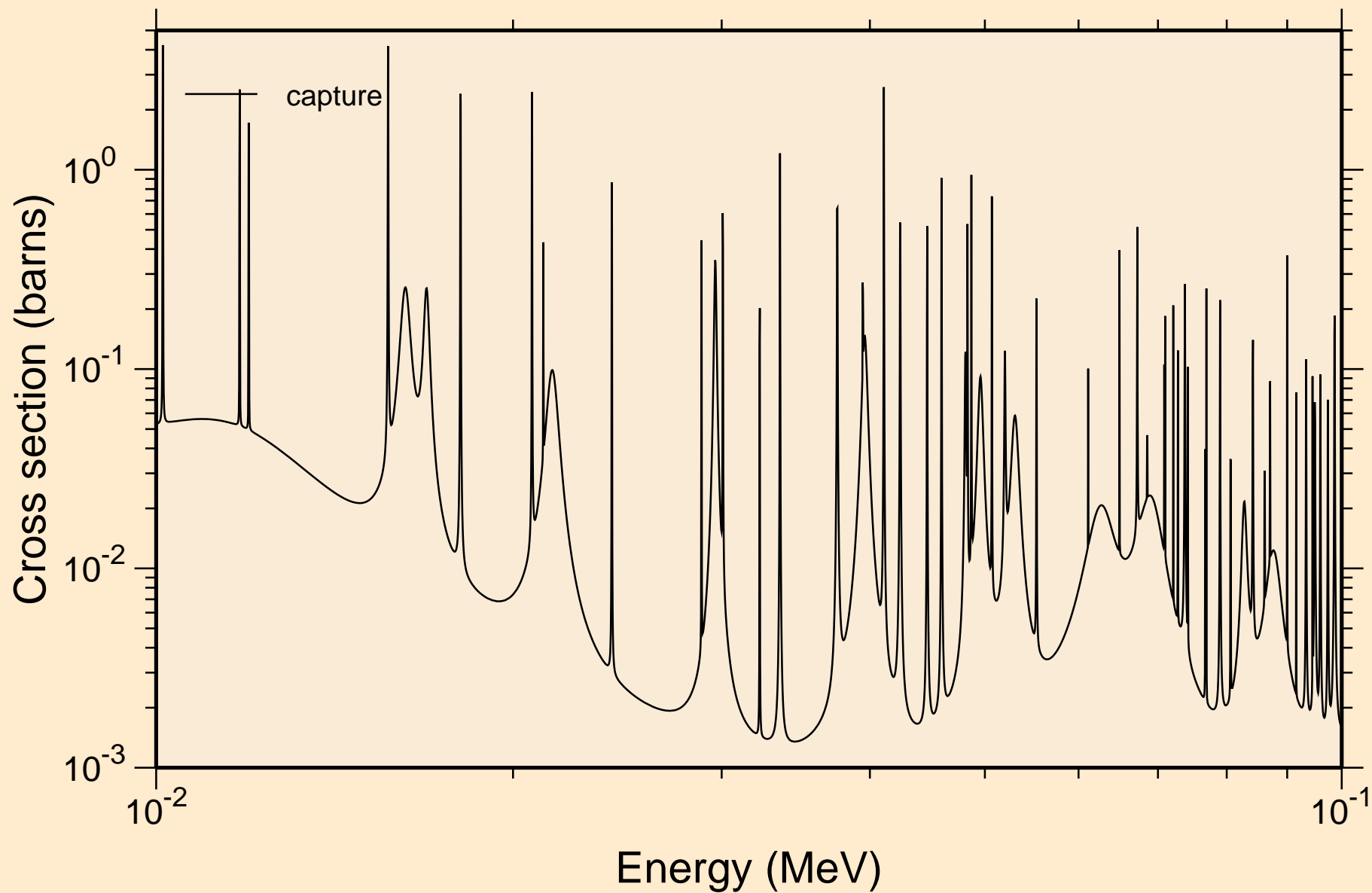

23-V-51 FOR FENDL-3.1 FROM FENDL-3.1 WITH NJOY2012.50+ C
resonance absorption cross sections

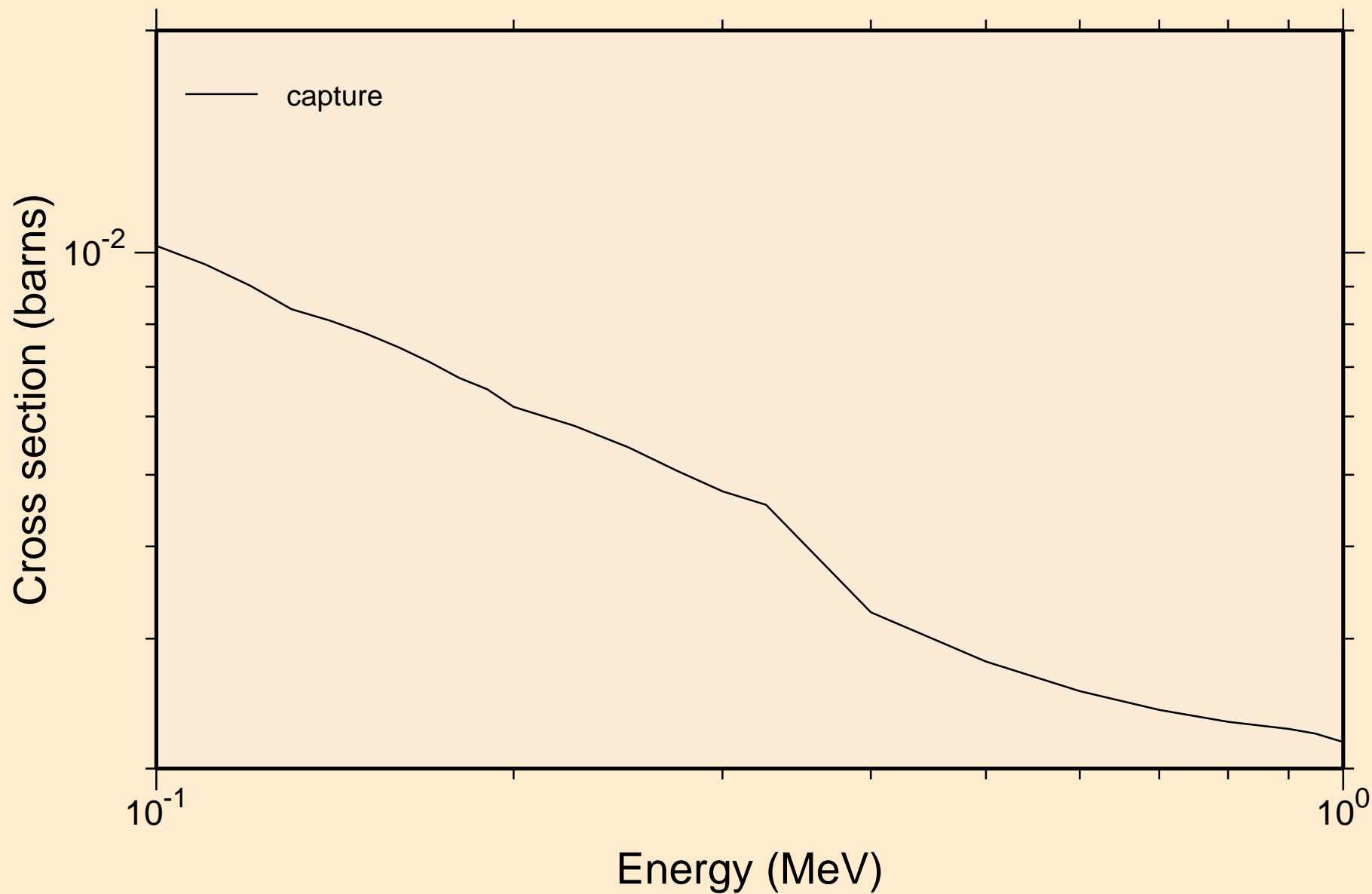

23-V-51 FOR FENDL-3.1 FROM FENDL-3.1 WITH NJOY2012.50+ C
resonance absorption cross sections

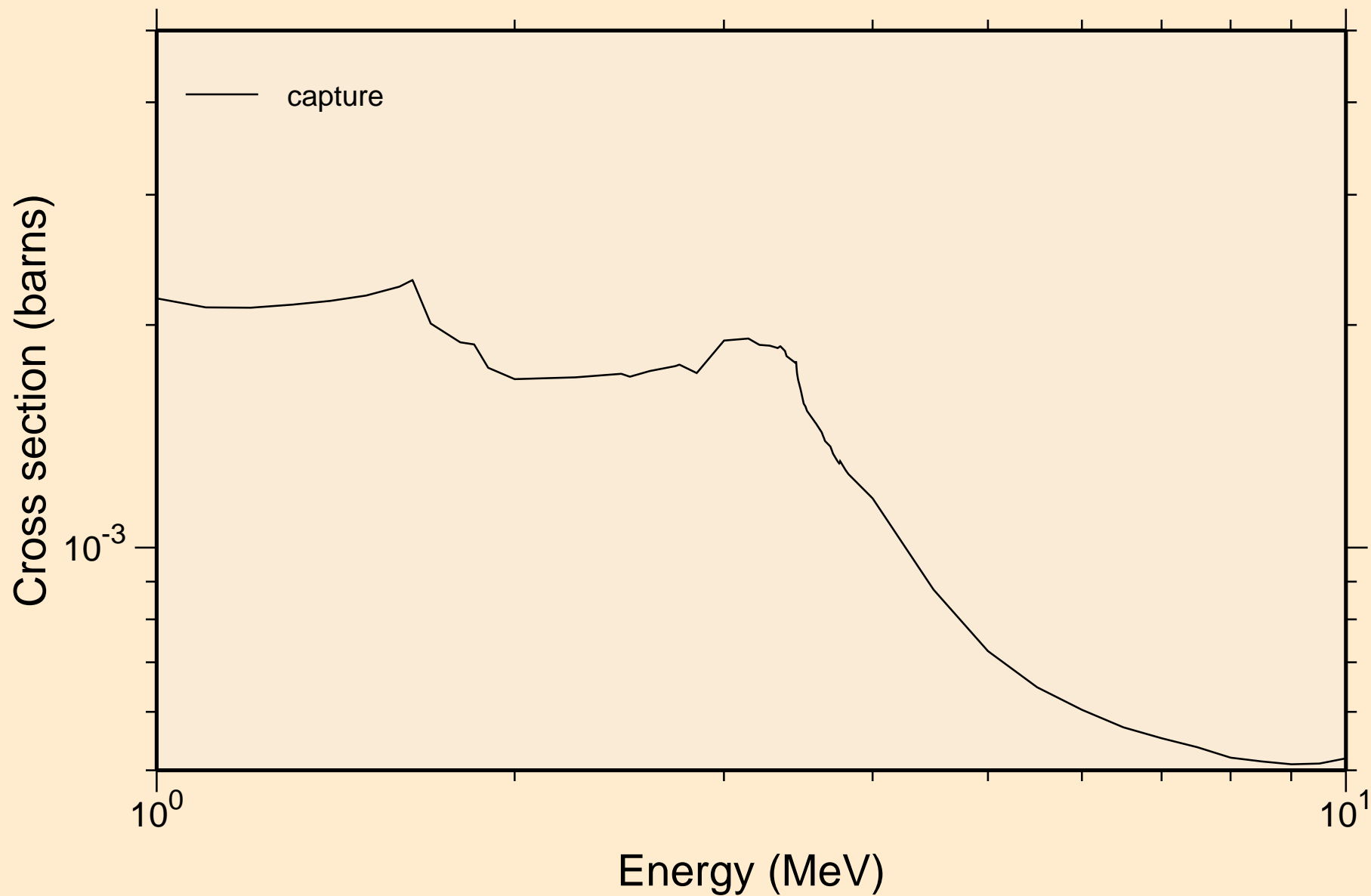

23-V-51 FOR FENDL-3.1 FROM FENDL-3.1 WITH NJOY2012.50+ C Heating

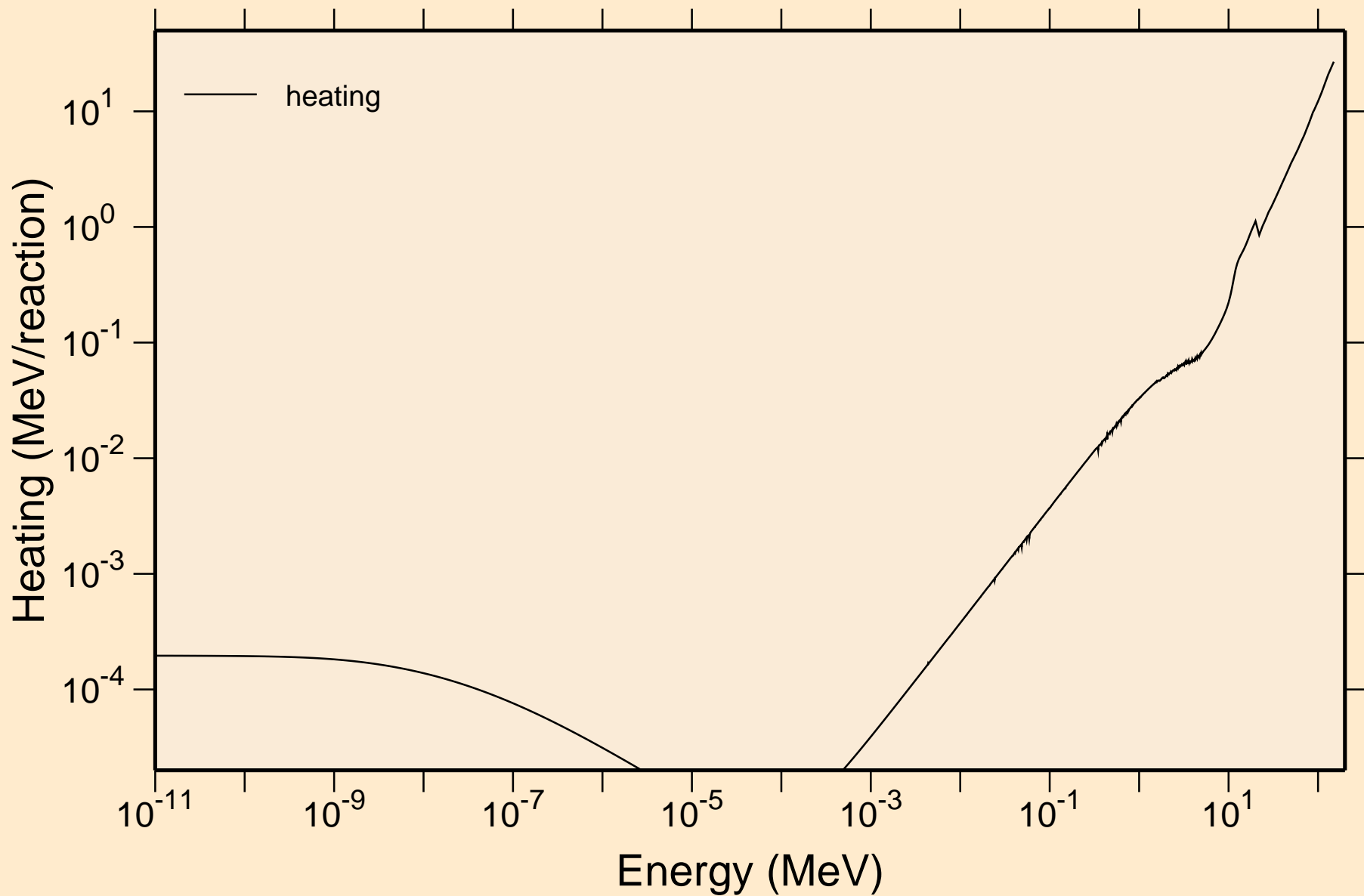

23-V-51 FOR FENDL-3.1 FROM FENDL-3.1 WITH NJOY2012.50+ C Damage

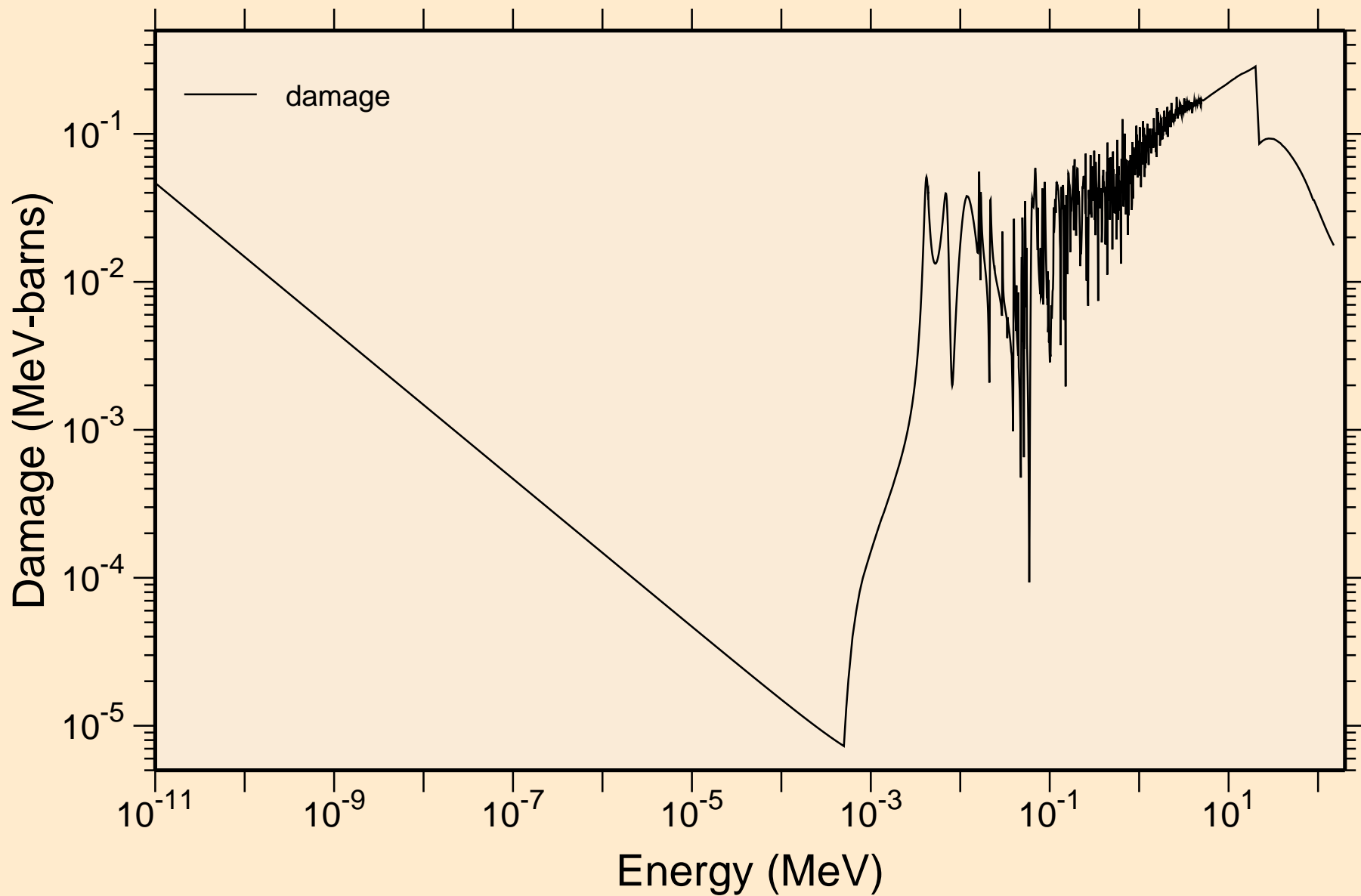

23-V-51 FOR FENDL-3.1 FROM FENDL-3.1 WITH NJOY2012.50+ C
Non-threshold reactions

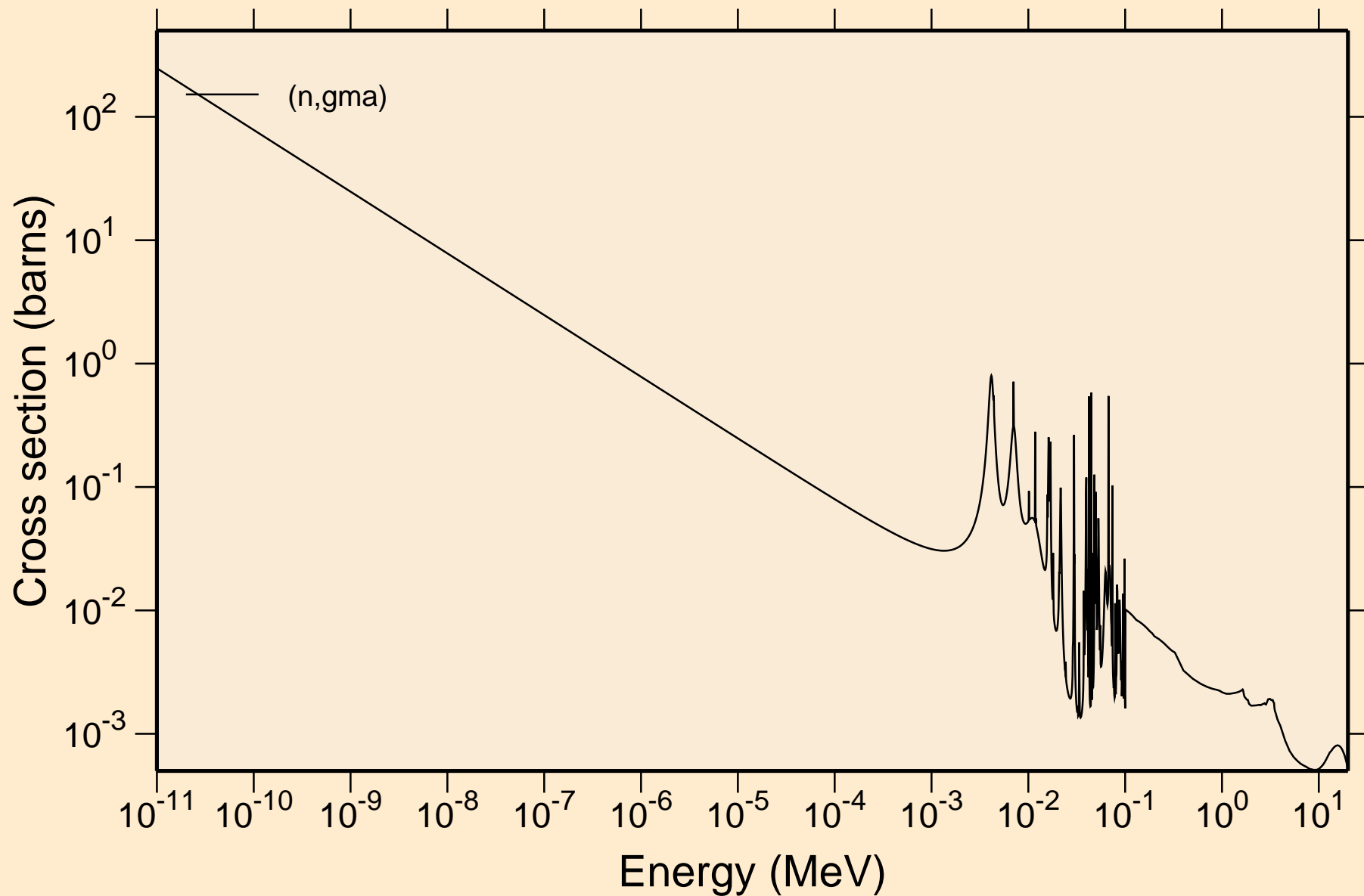

23-V-51 FOR FENDL-3.1 FROM FENDL-3.1 WITH NJOY2012.50+ C
Principal cross sections

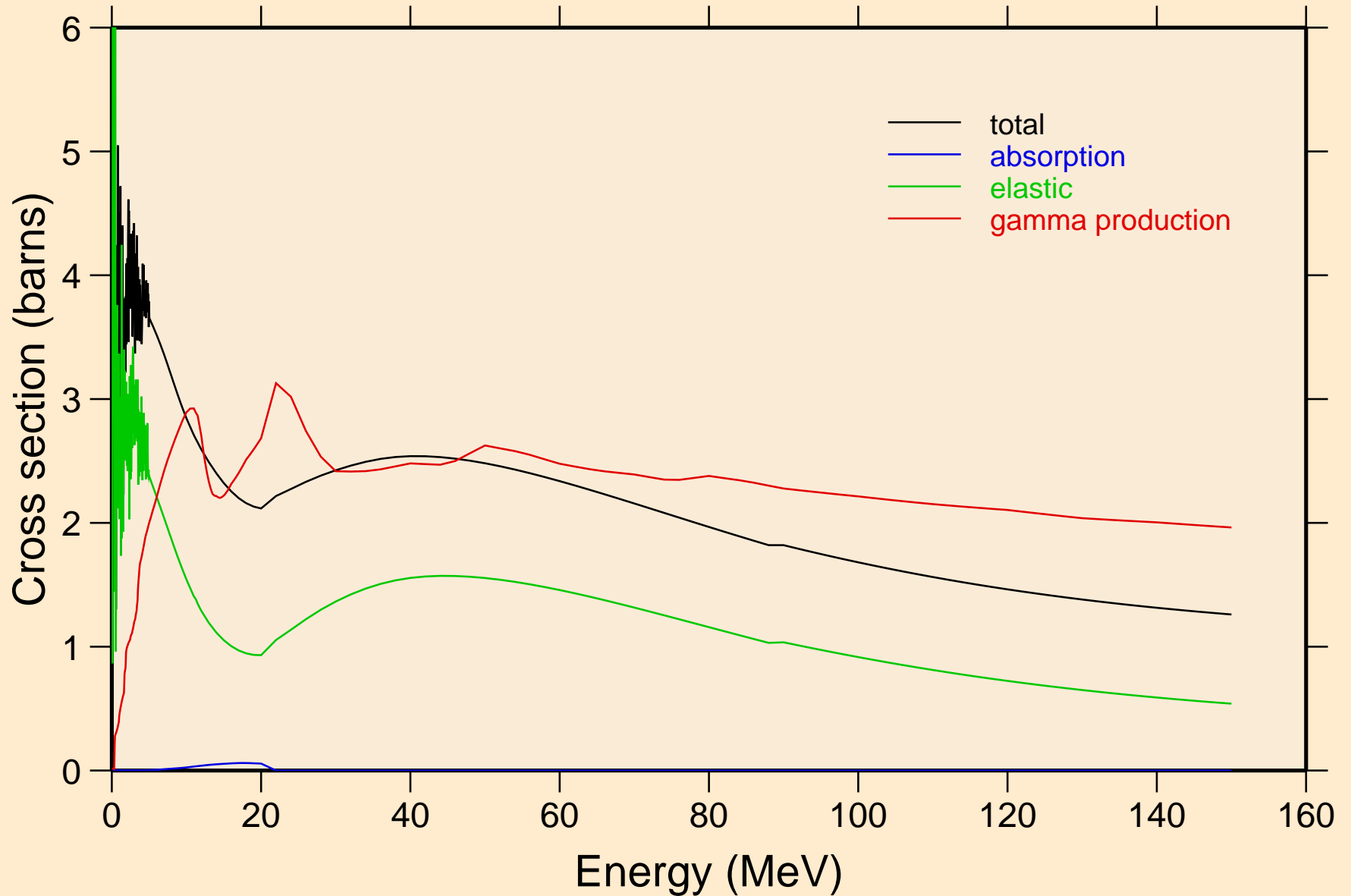

23-V-51 FOR FENDL-3.1 FROM FENDL-3.1 WITH NJOY2012.50+ C Heating

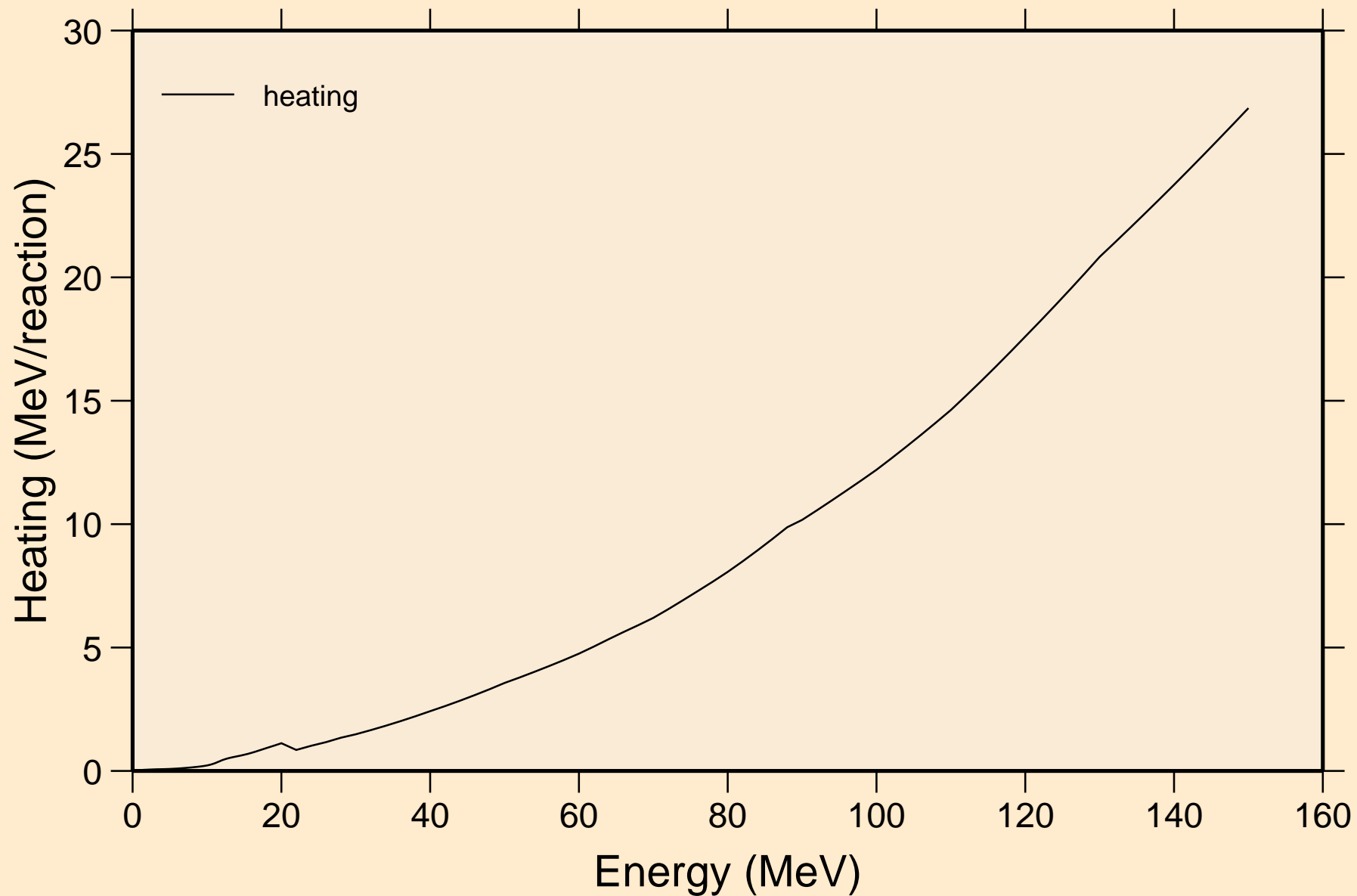

23-V-51 FOR FENDL-3.1 FROM FENDL-3.1 WITH NJOY2012.50+ C Damage

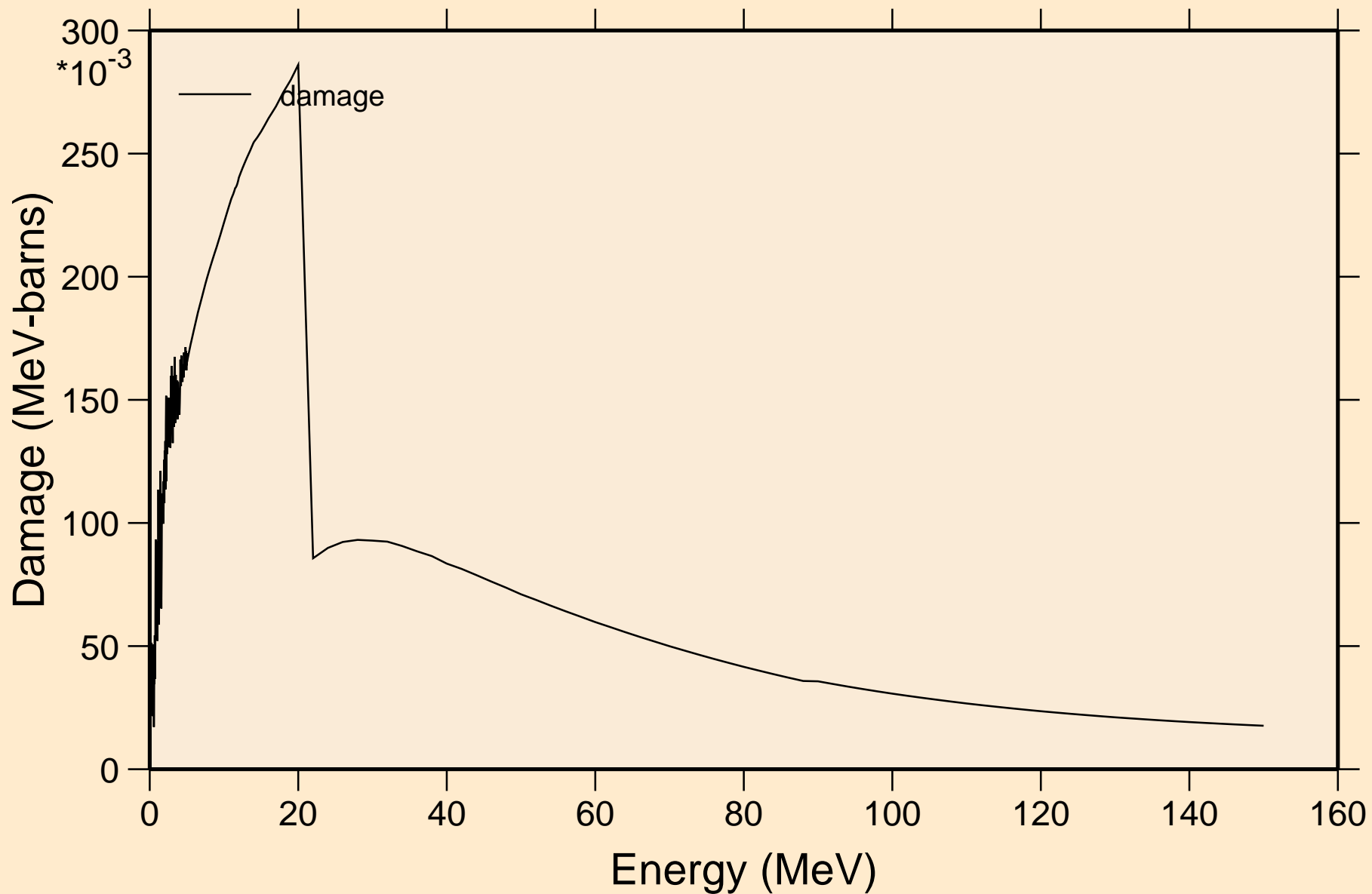

23-V-51 FOR FENDL-3.1 FROM FENDL-3.1 WITH NJOY2012.50+ C
Non-threshold reactions

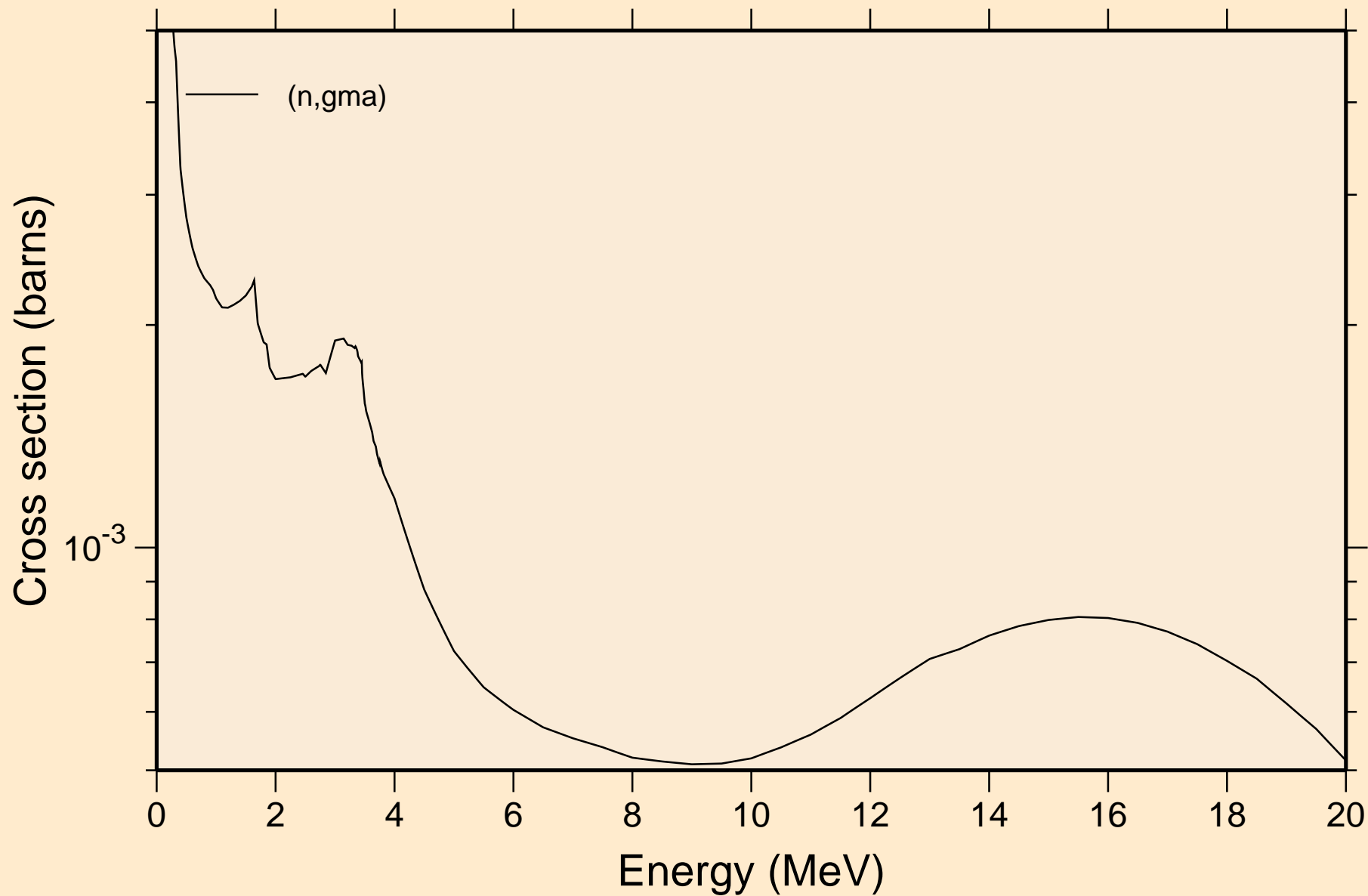

23-V-51 FOR FENDL-3.1 FROM FENDL-3.1 WITH NJOY2012.50+ C Inelastic levels

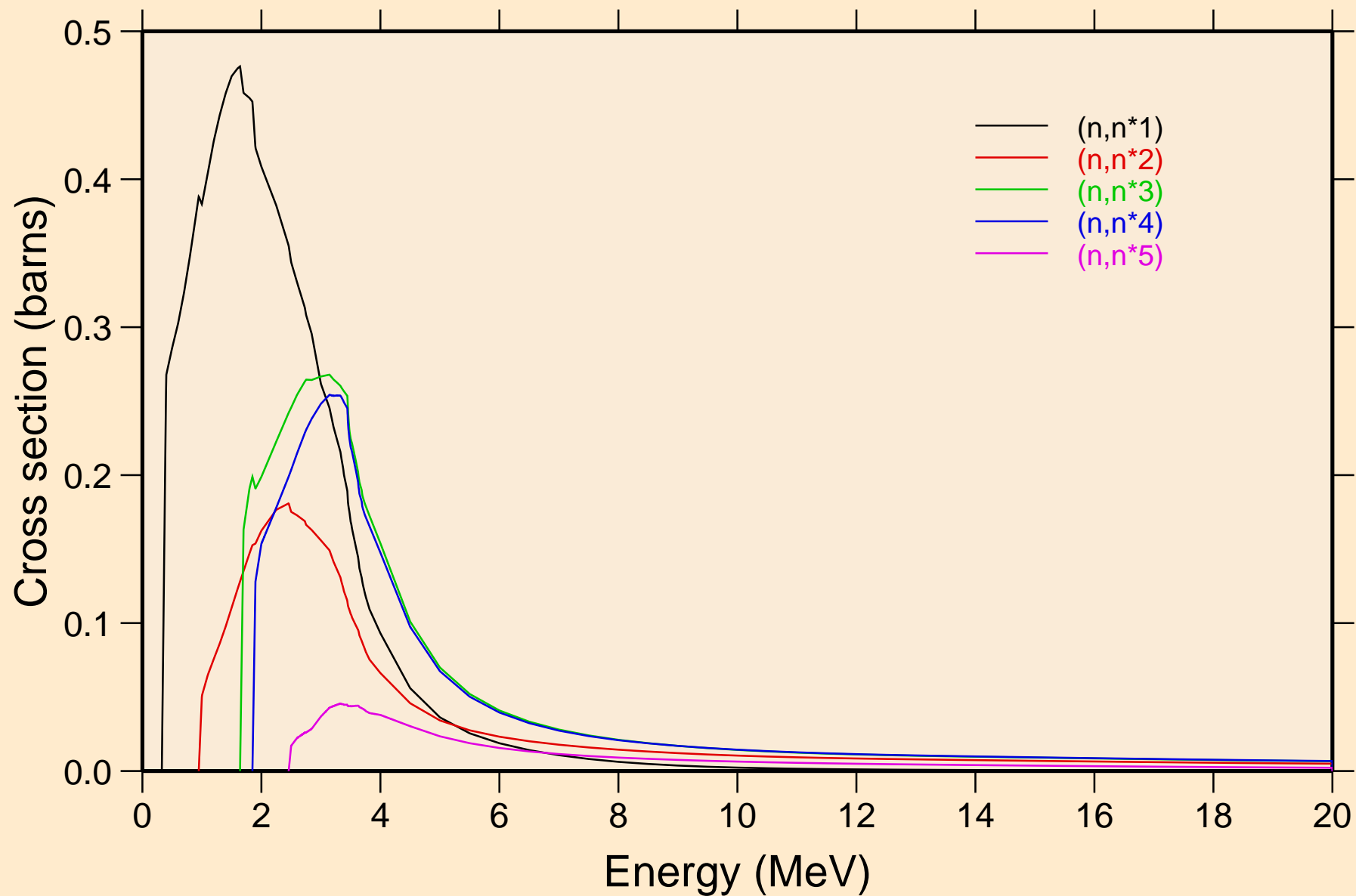

23-V-51 FOR FENDL-3.1 FROM FENDL-3.1 WITH NJOY2012.50+ C
Inelastic levels

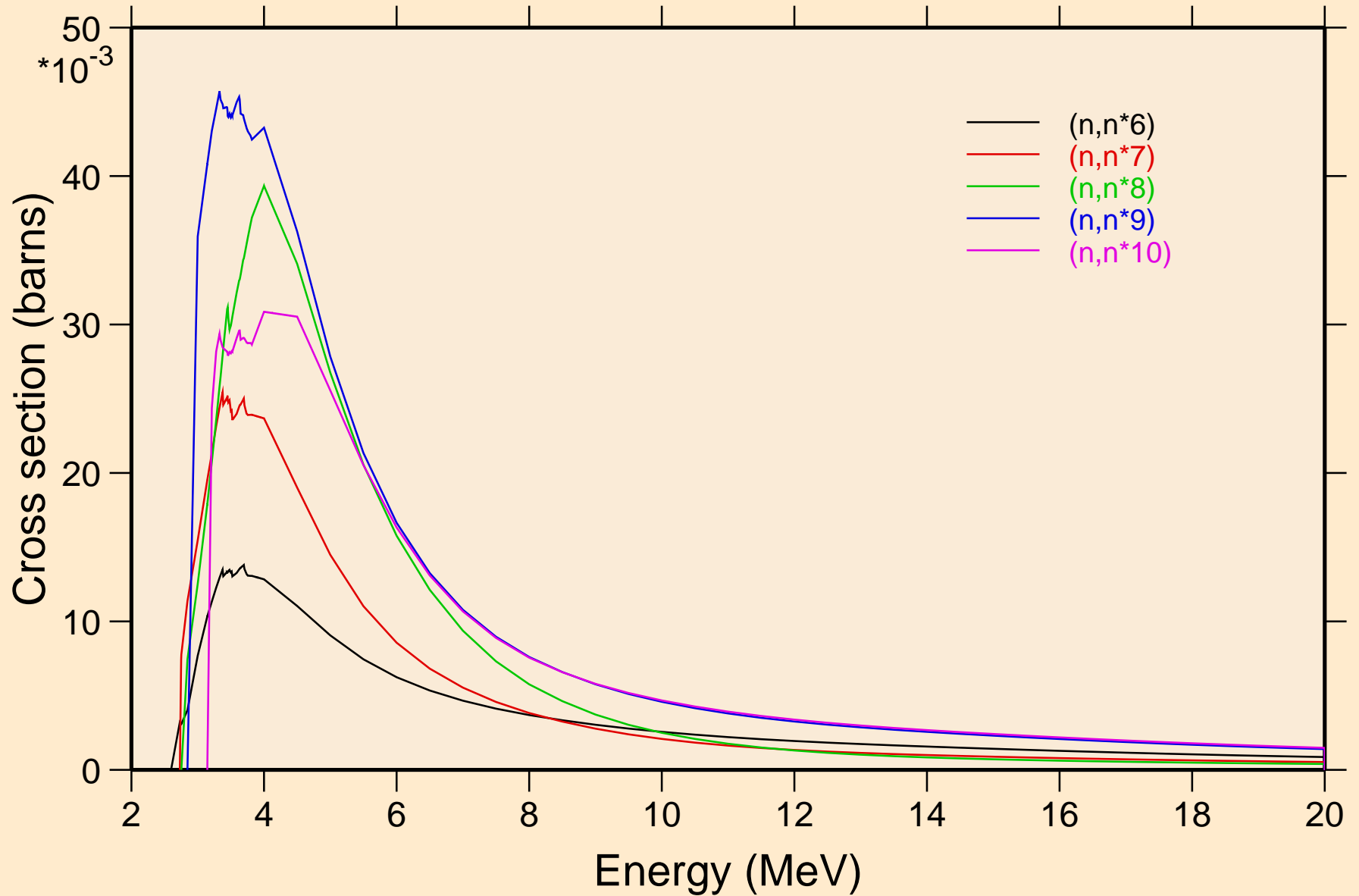

23-V-51 FOR FENDL-3.1 FROM FENDL-3.1 WITH NJOY2012.50+ C Inelastic levels

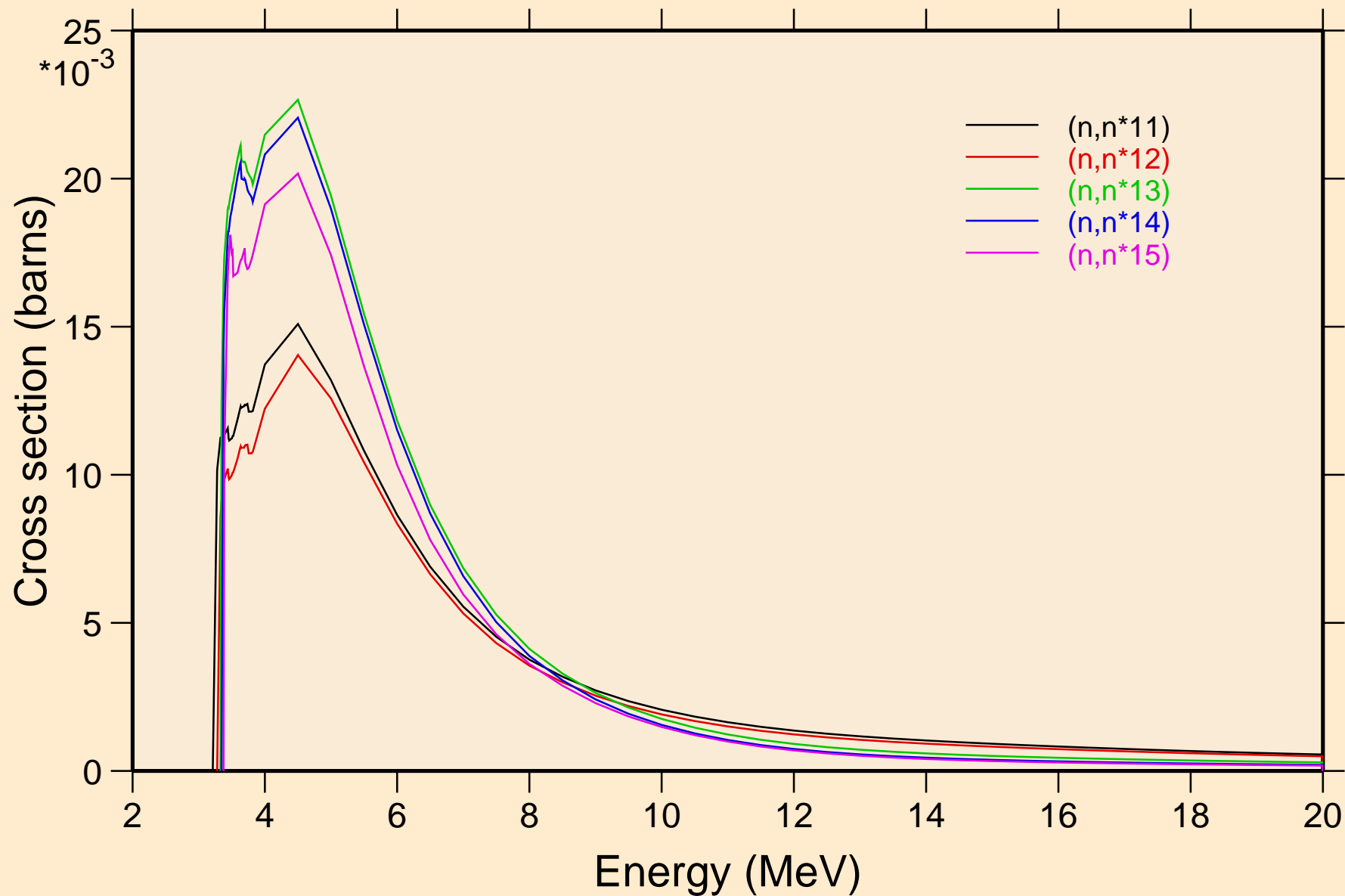

23-V-51 FOR FENDL-3.1 FROM FENDL-3.1 WITH NJOY2012.50+ C Inelastic levels

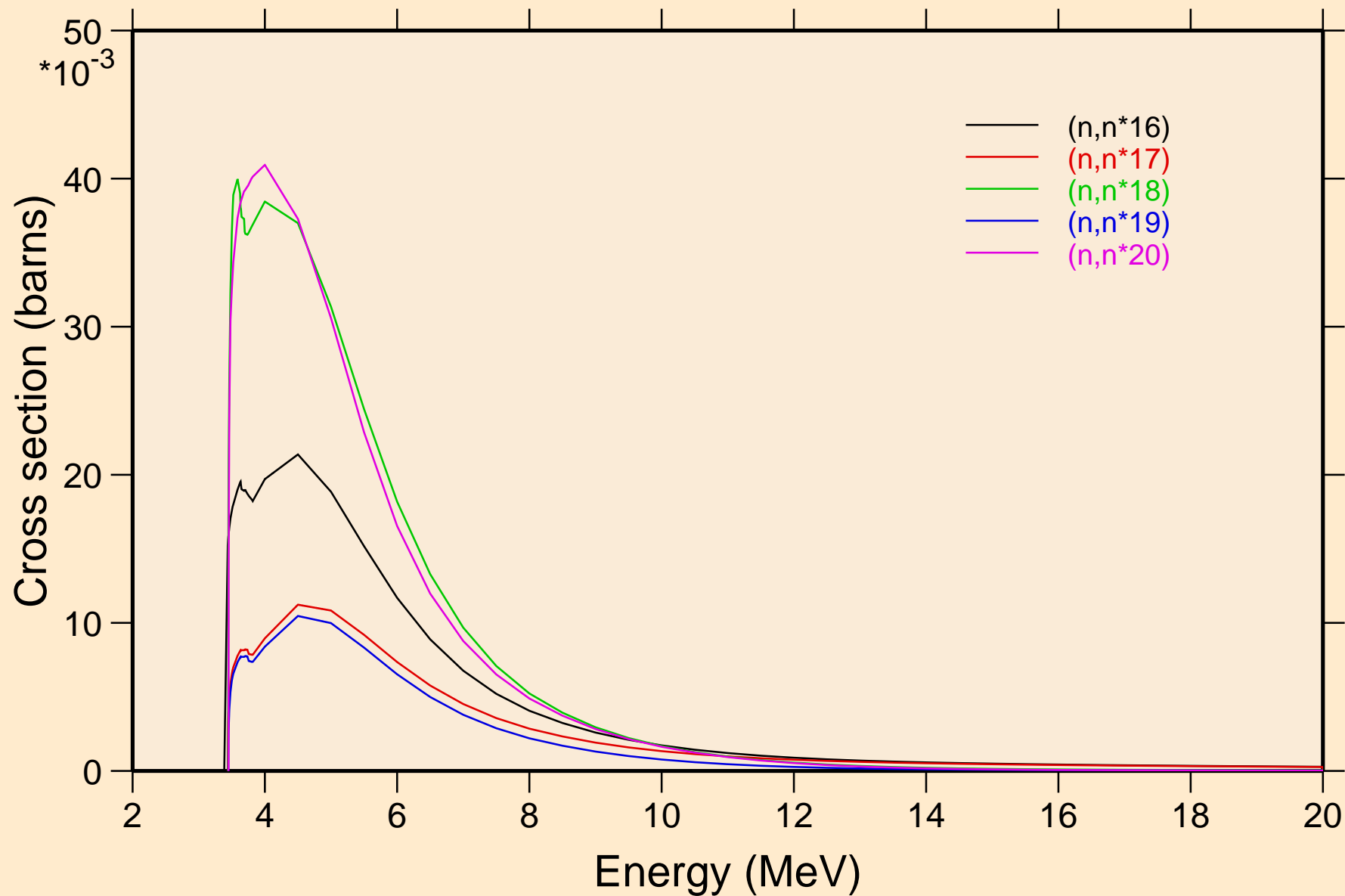

23-V-51 FOR FENDL-3.1 FROM FENDL-3.1 WITH NJOY2012.50+ C Inelastic levels

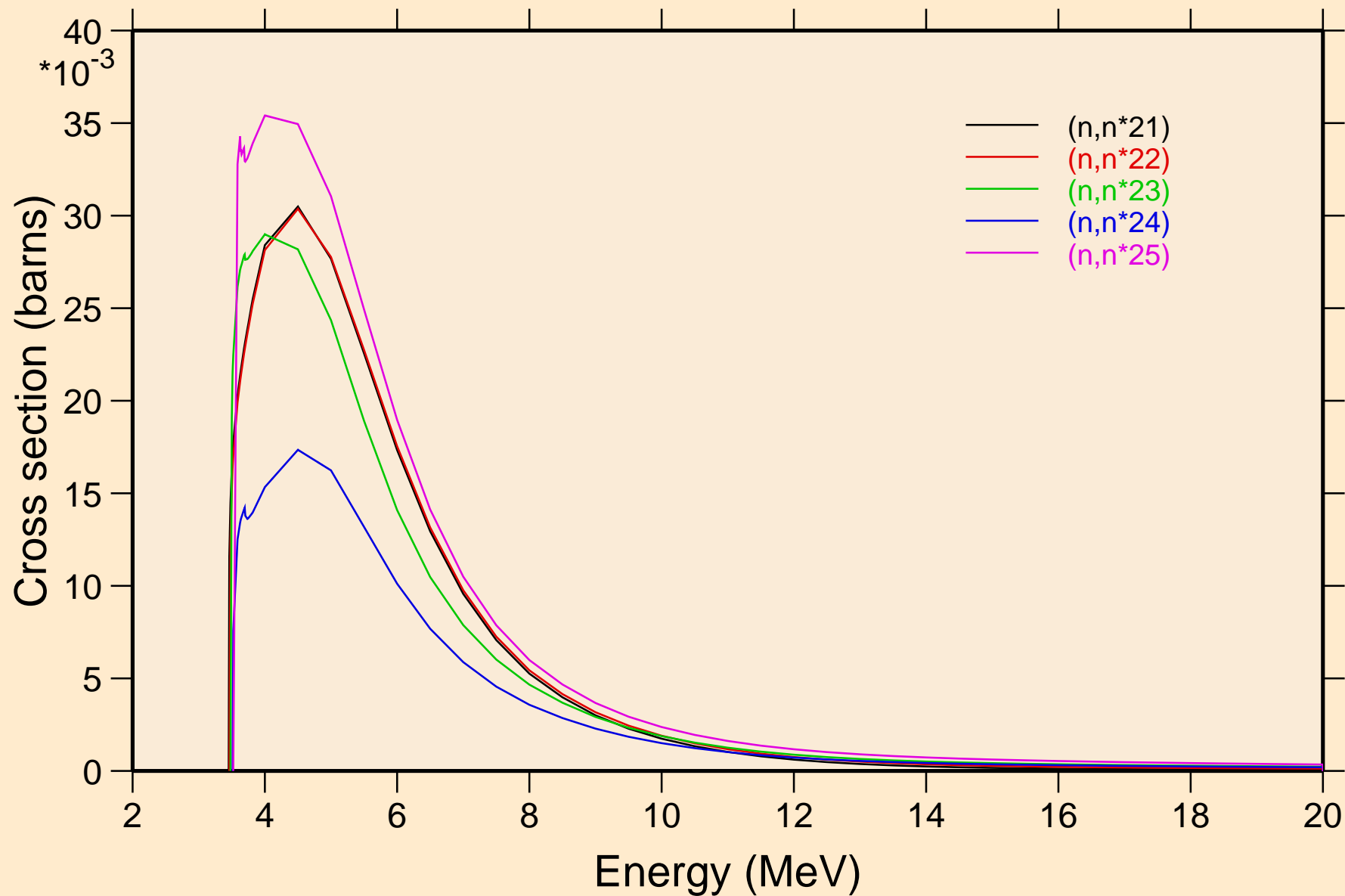

23-V-51 FOR FENDL-3.1 FROM FENDL-3.1 WITH NJOY2012.50+ C Inelastic levels

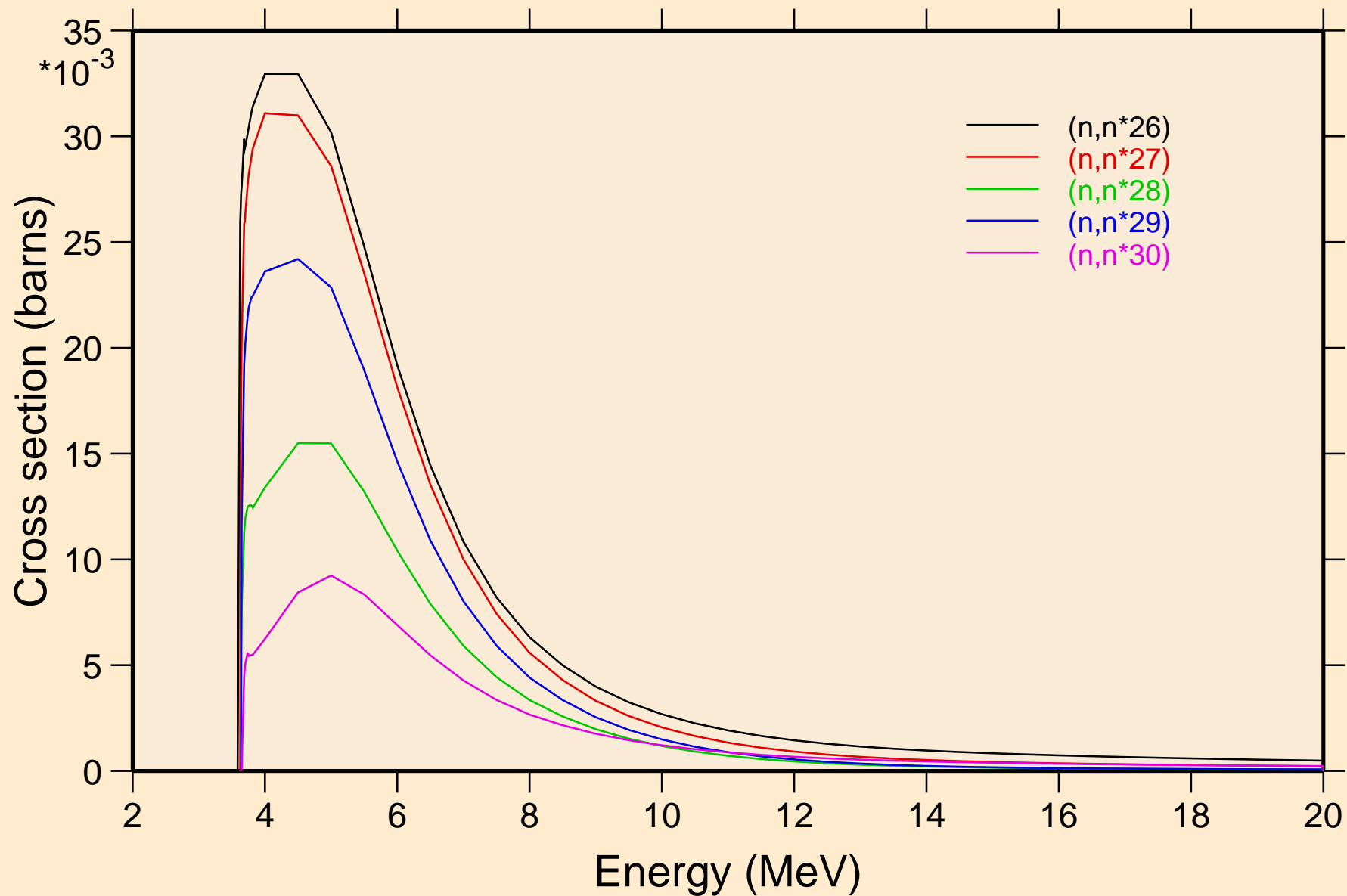

23-V-51 FOR FENDL-3.1 FROM FENDL-3.1 WITH NJOY2012.50+ C Inelastic levels

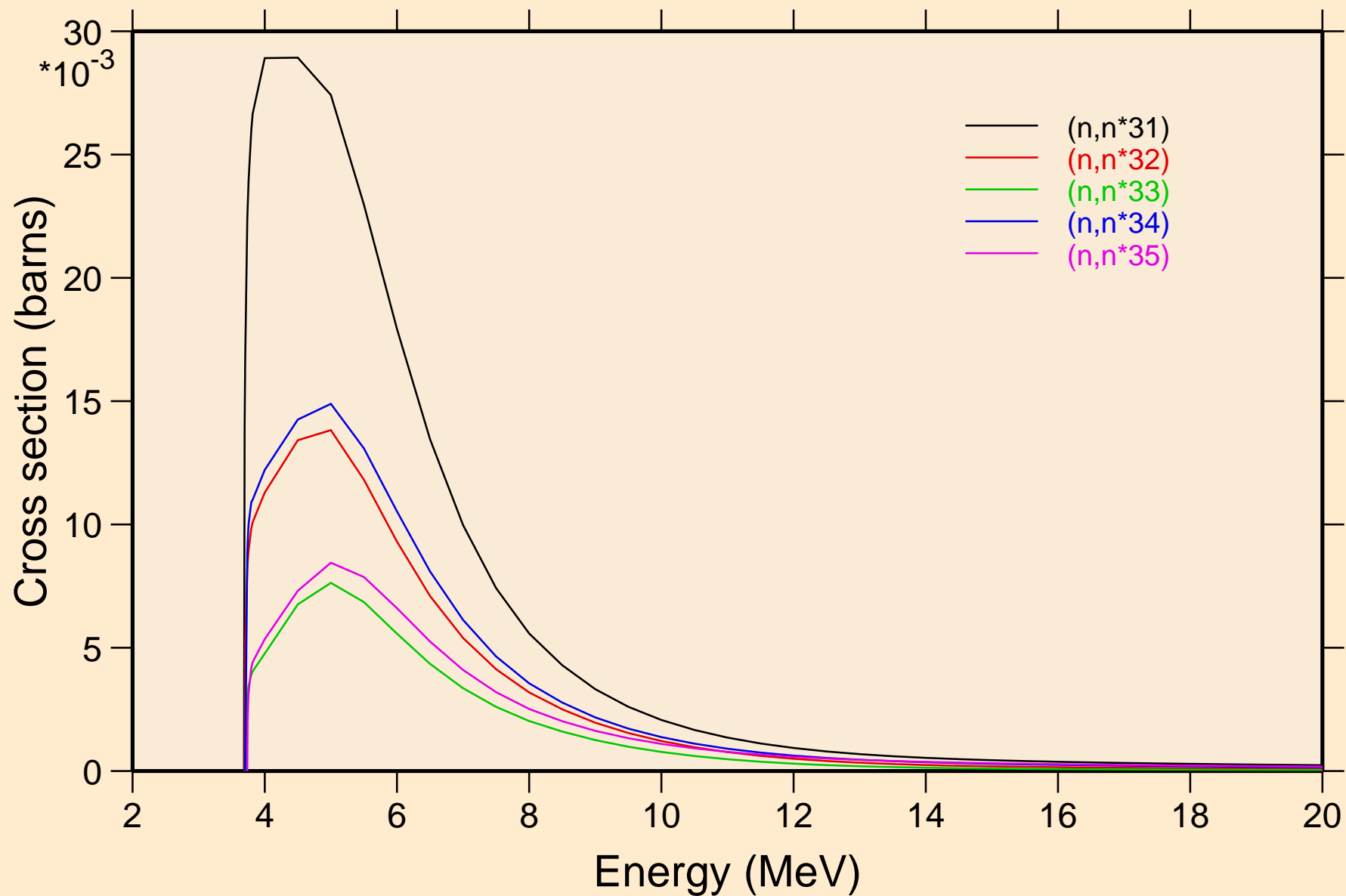

23-V-51 FOR FENDL-3.1 FROM FENDL-3.1 WITH NJOY2012.50+ C Inelastic levels

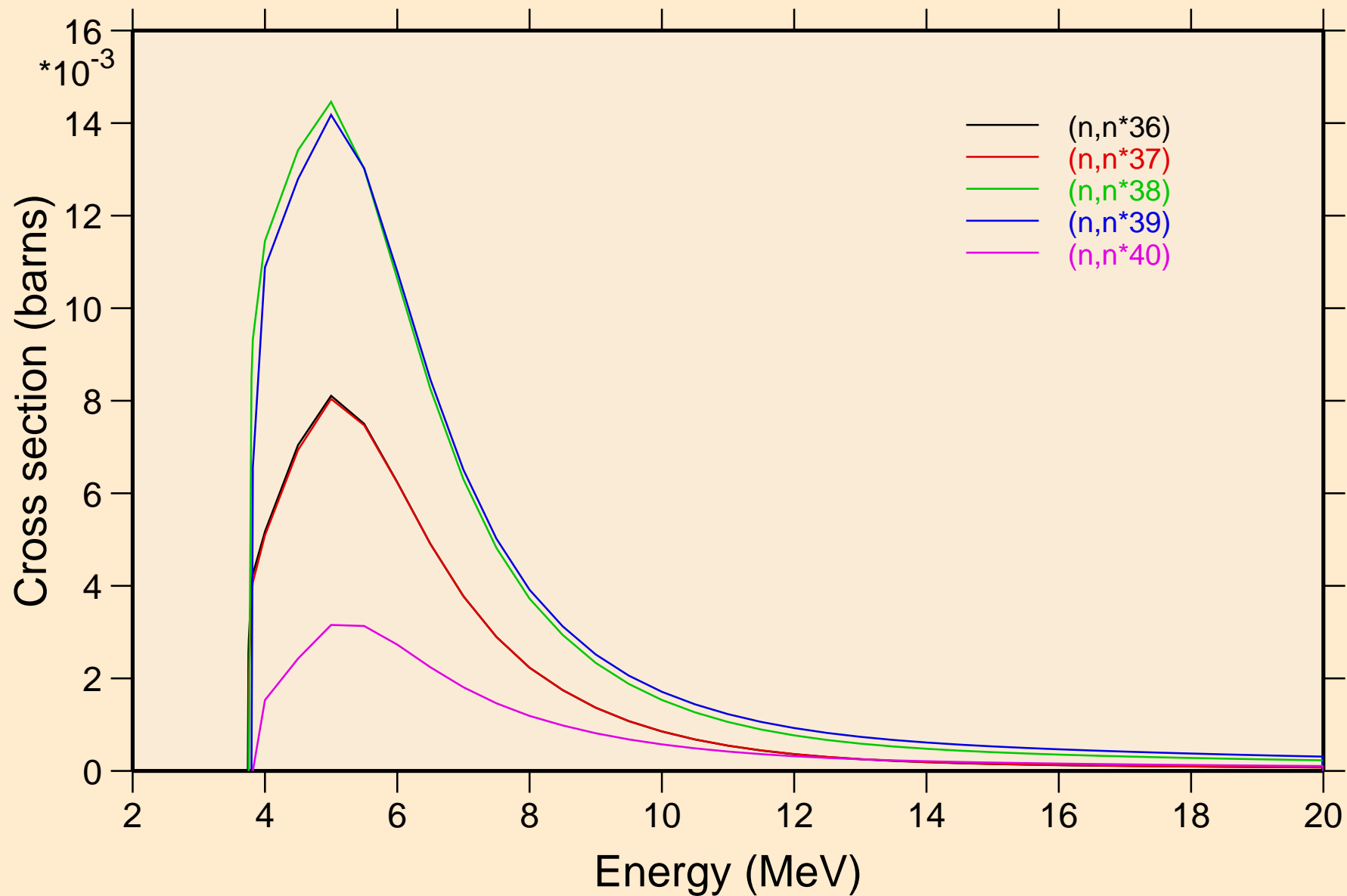

23-V-51 FOR FENDL-3.1 FROM FENDL-3.1 WITH NJOY2012.50+ C

Threshold reactions

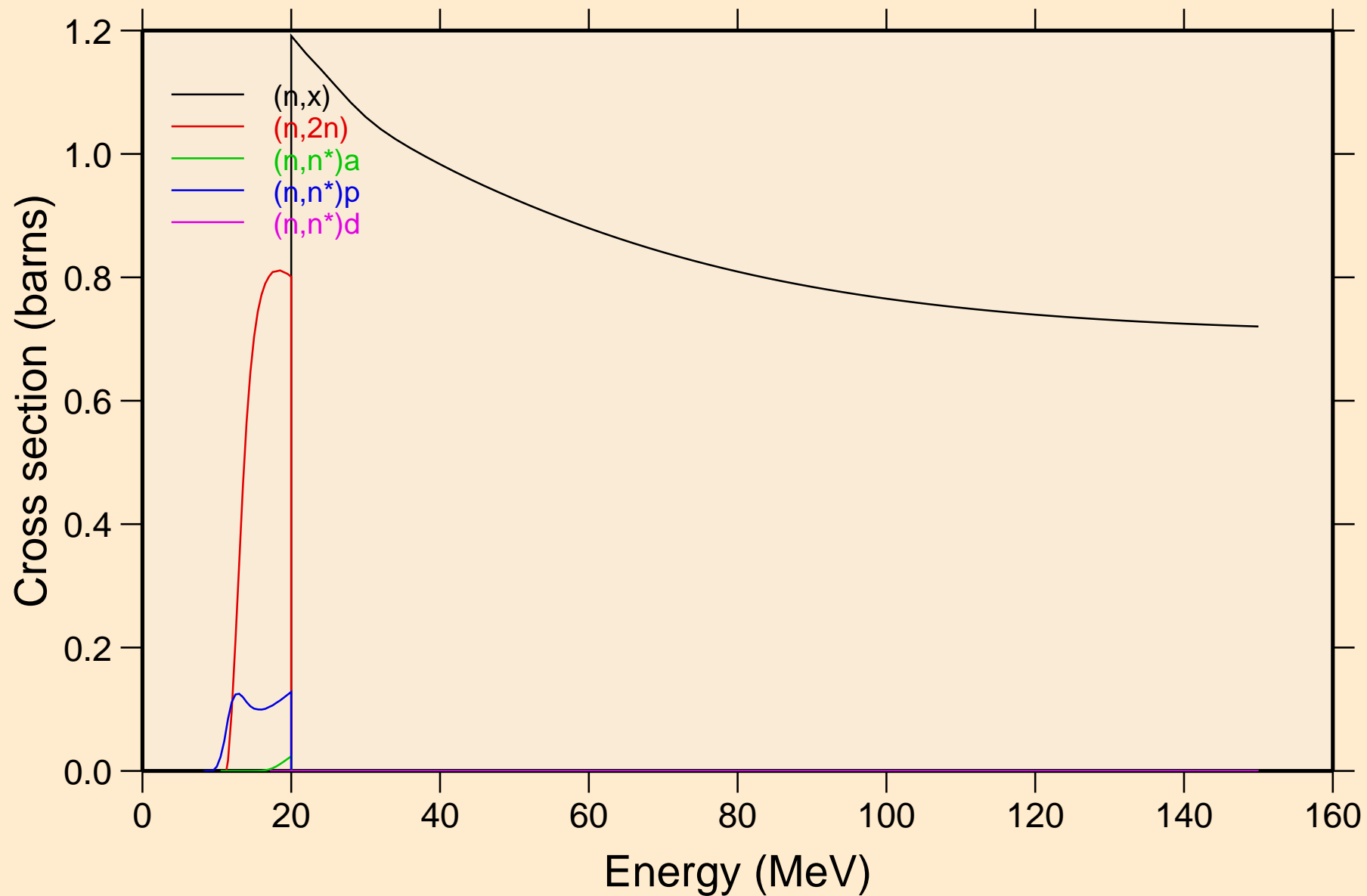

23-V-51 FOR FENDL-3.1 FROM FENDL-3.1 WITH NJOY2012.50+ C
Threshold reactions

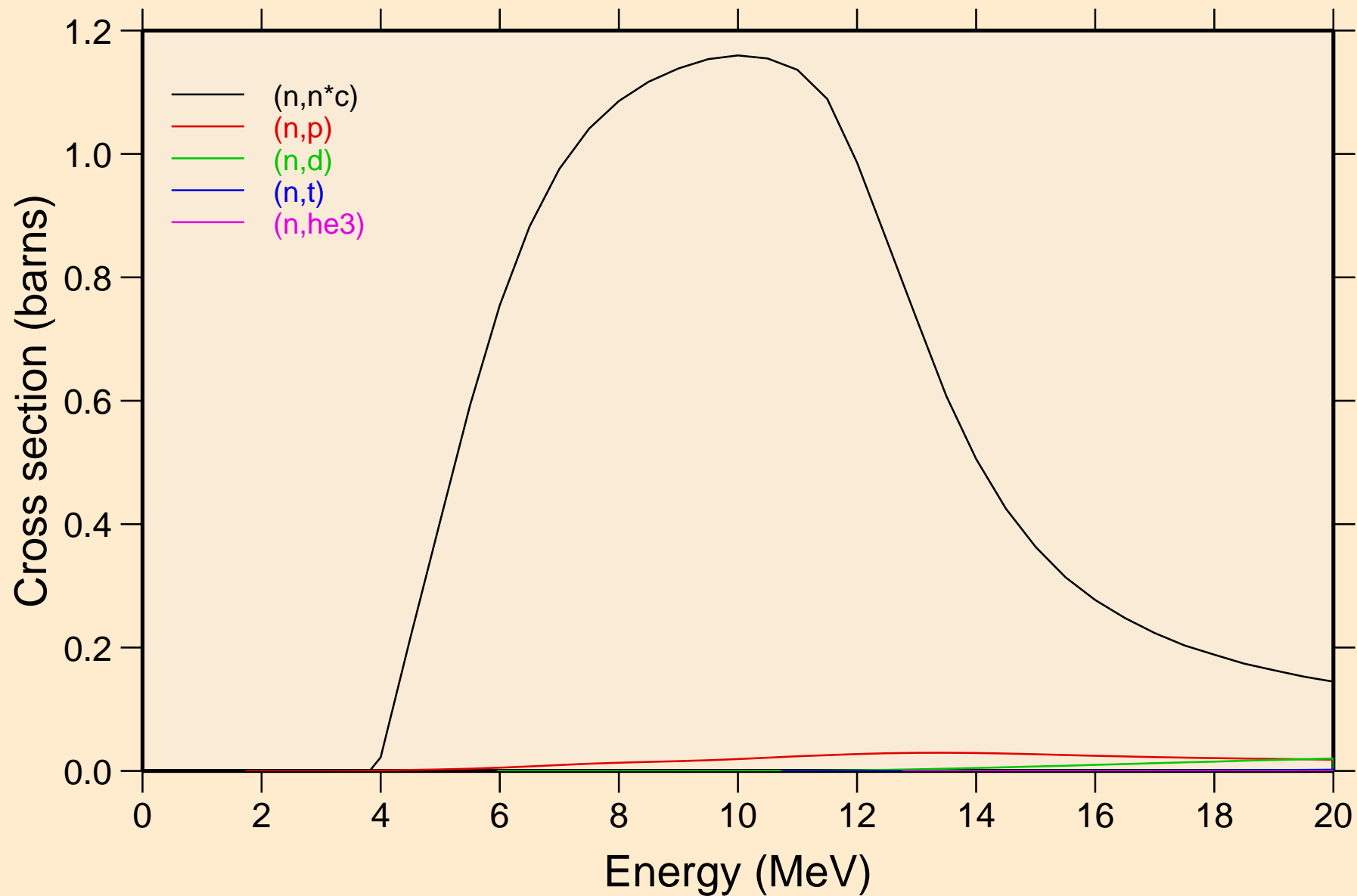

23-V-51 FOR FENDL-3.1 FROM FENDL-3.1 WITH NJOY2012.50+ C
Threshold reactions

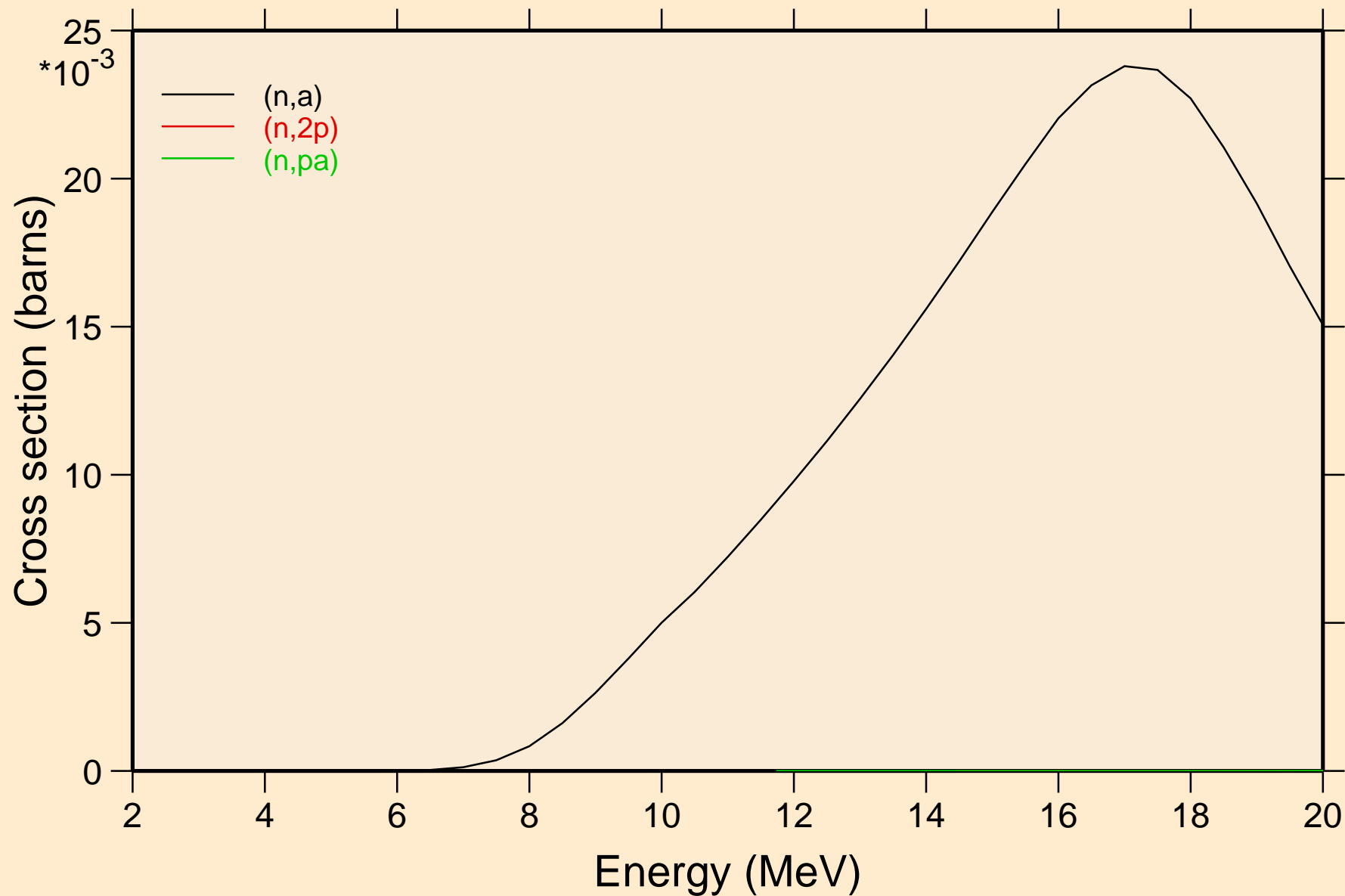

23-V-51 FOR FENDL-3.1 FROM FENDL-3.1 WITH NJOY2012.50+ C

Threshold reactions

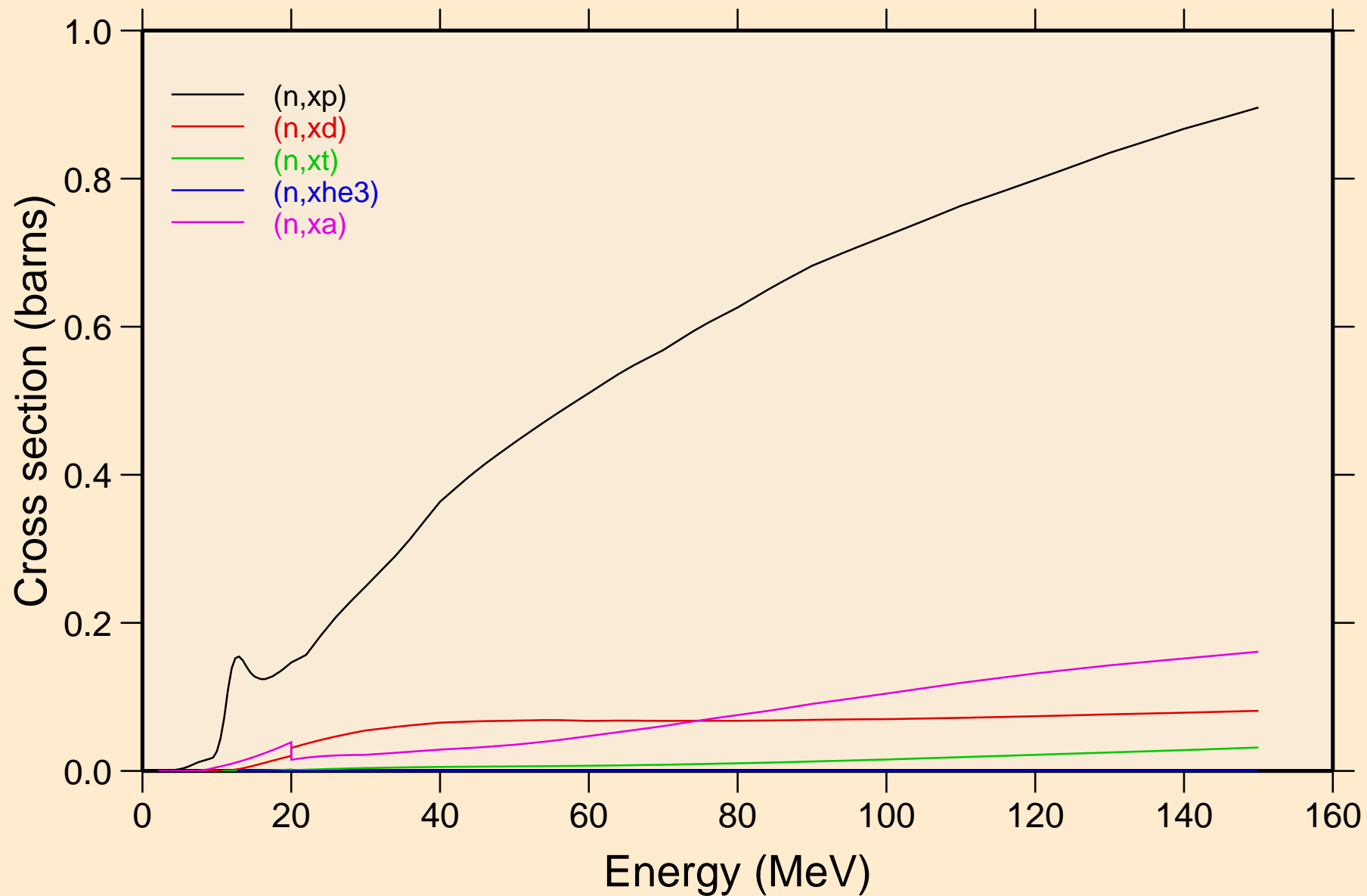

23-V-51 FOR FENDL-3.1 FROM FENDL-3.1 WITH NJOY2012.50+ C
angular distribution for elastic

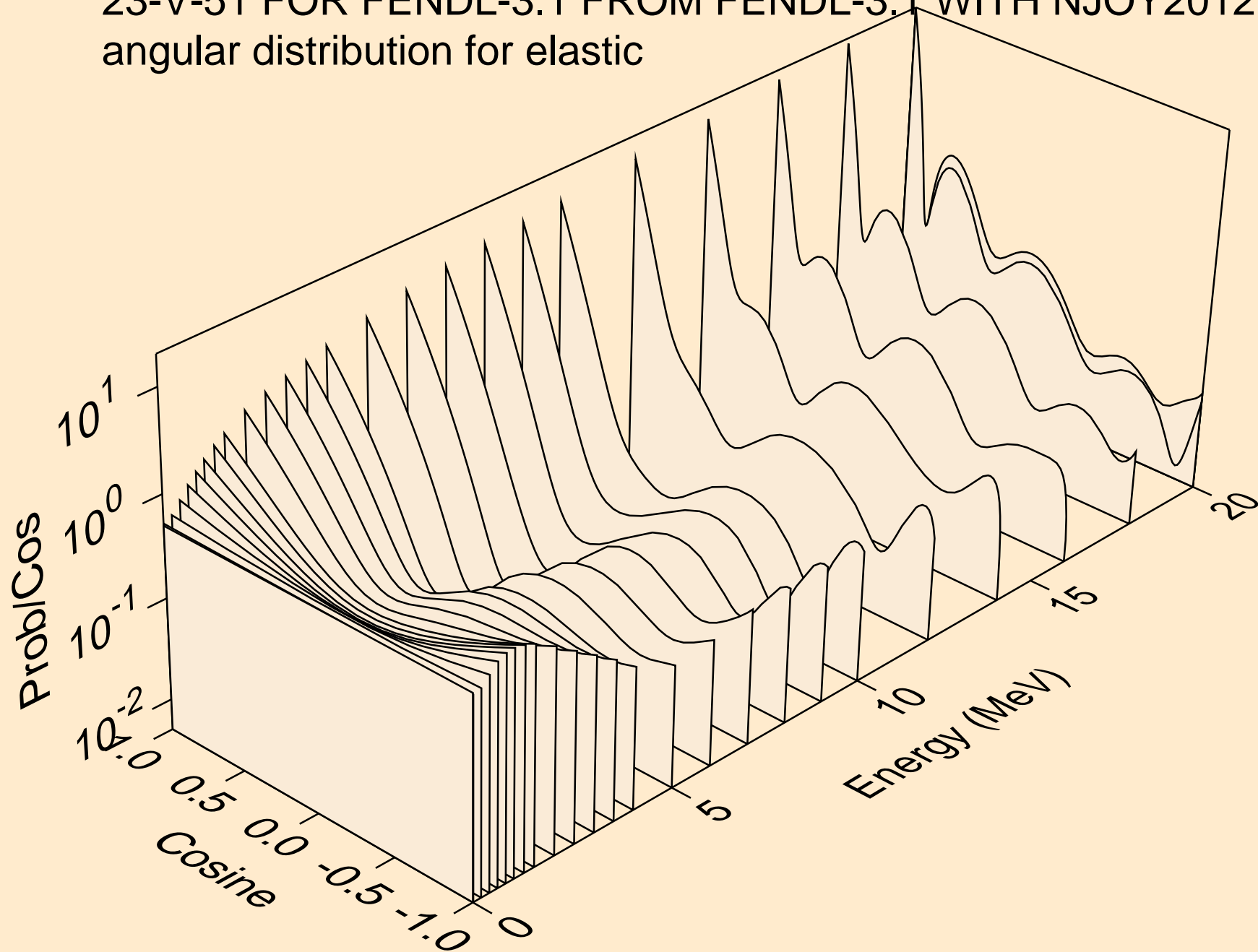

23-V-51 FOR FENDL-3.1 FROM FENDL-3.1 WITH NJOY2012.50+ C
angular distribution for elastic

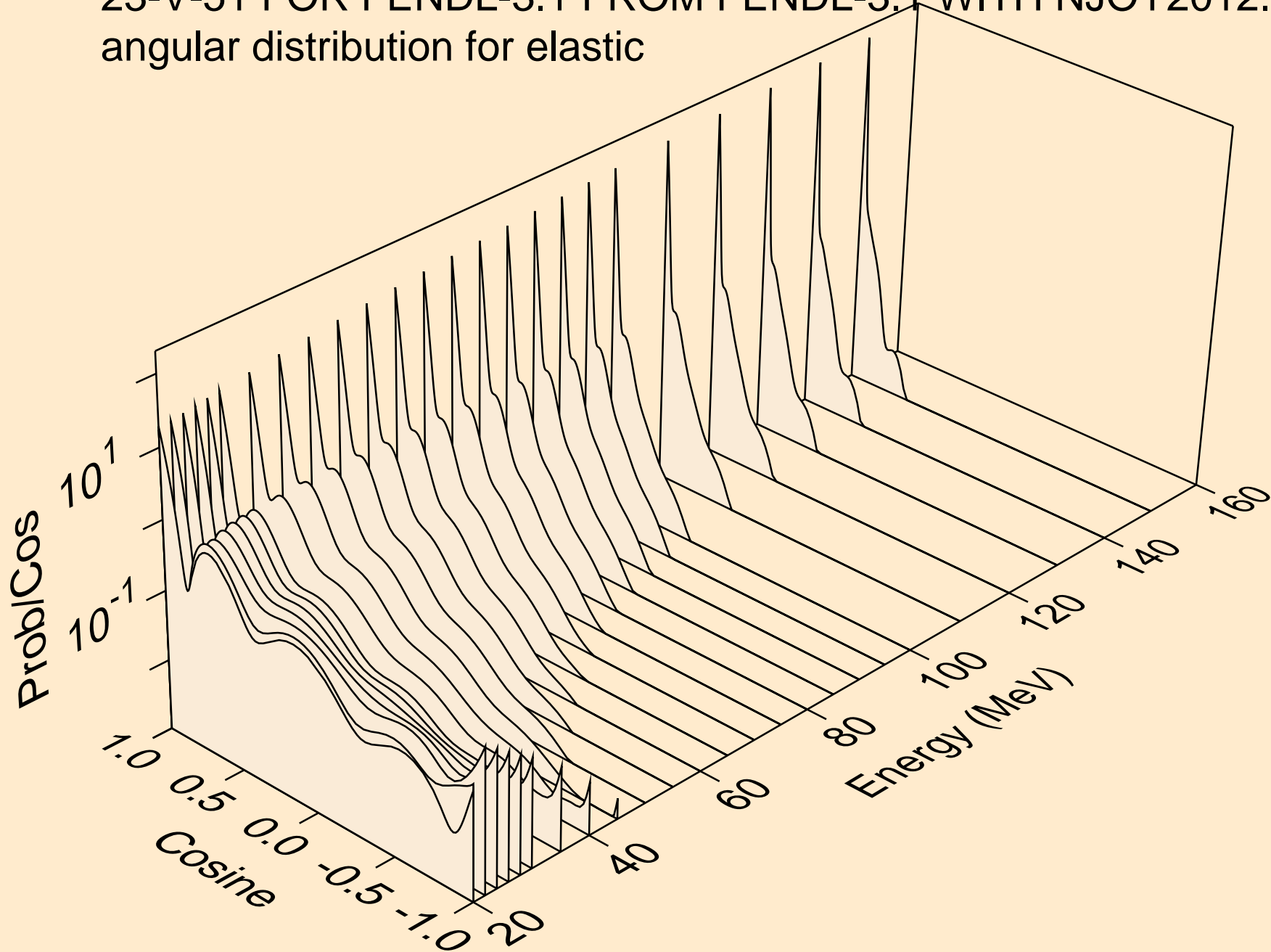

23-V-51 FOR FENDL-3.1 FROM FENDL-3.1 WITH NJOY2012.50+ C
angular distribution for (n,n*1)

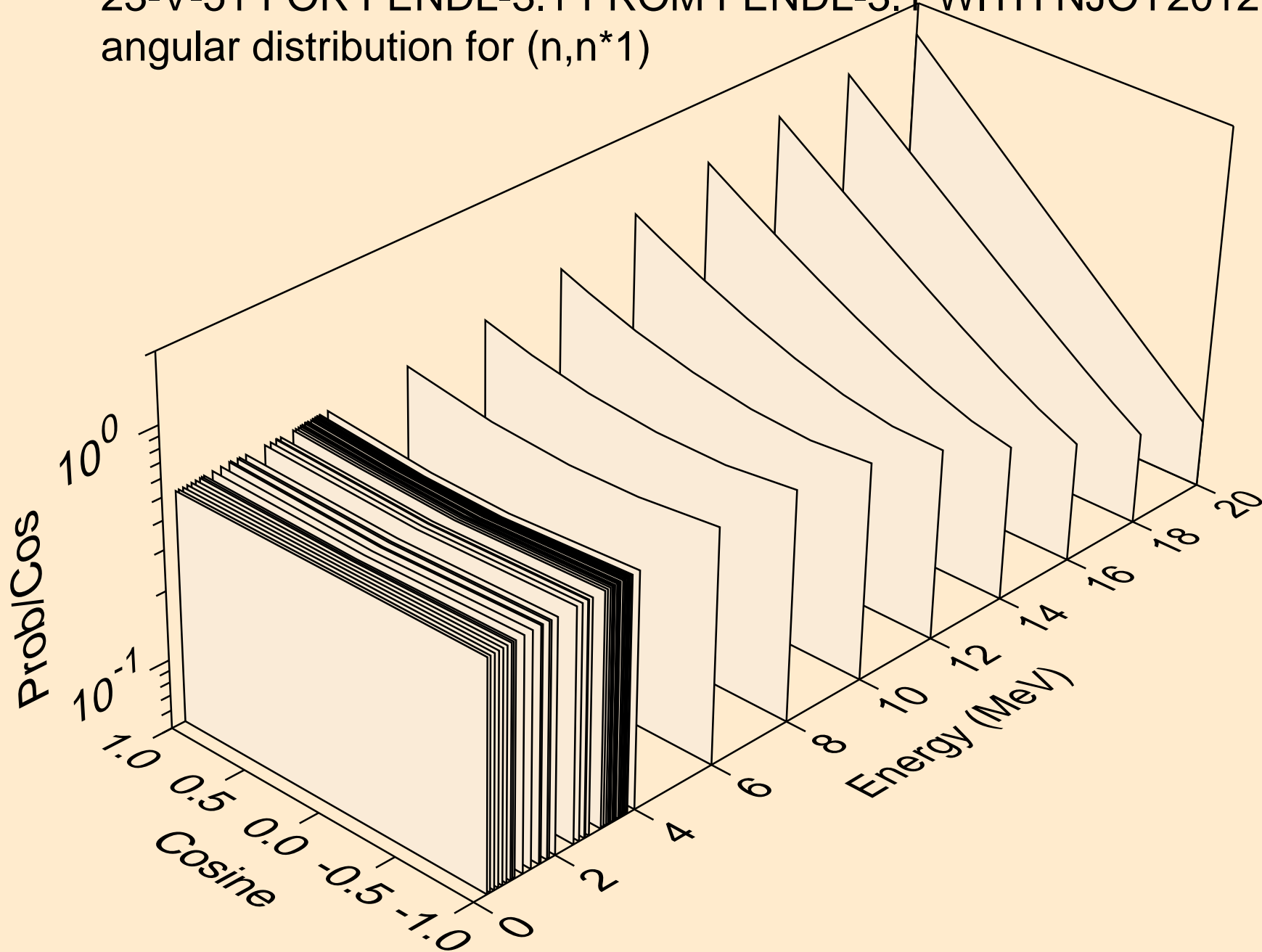

23-V-51 FOR FENDL-3.1 FROM FENDL-3.1 WITH NJOY2012.50+ C
angular distribution for (n,n*2)

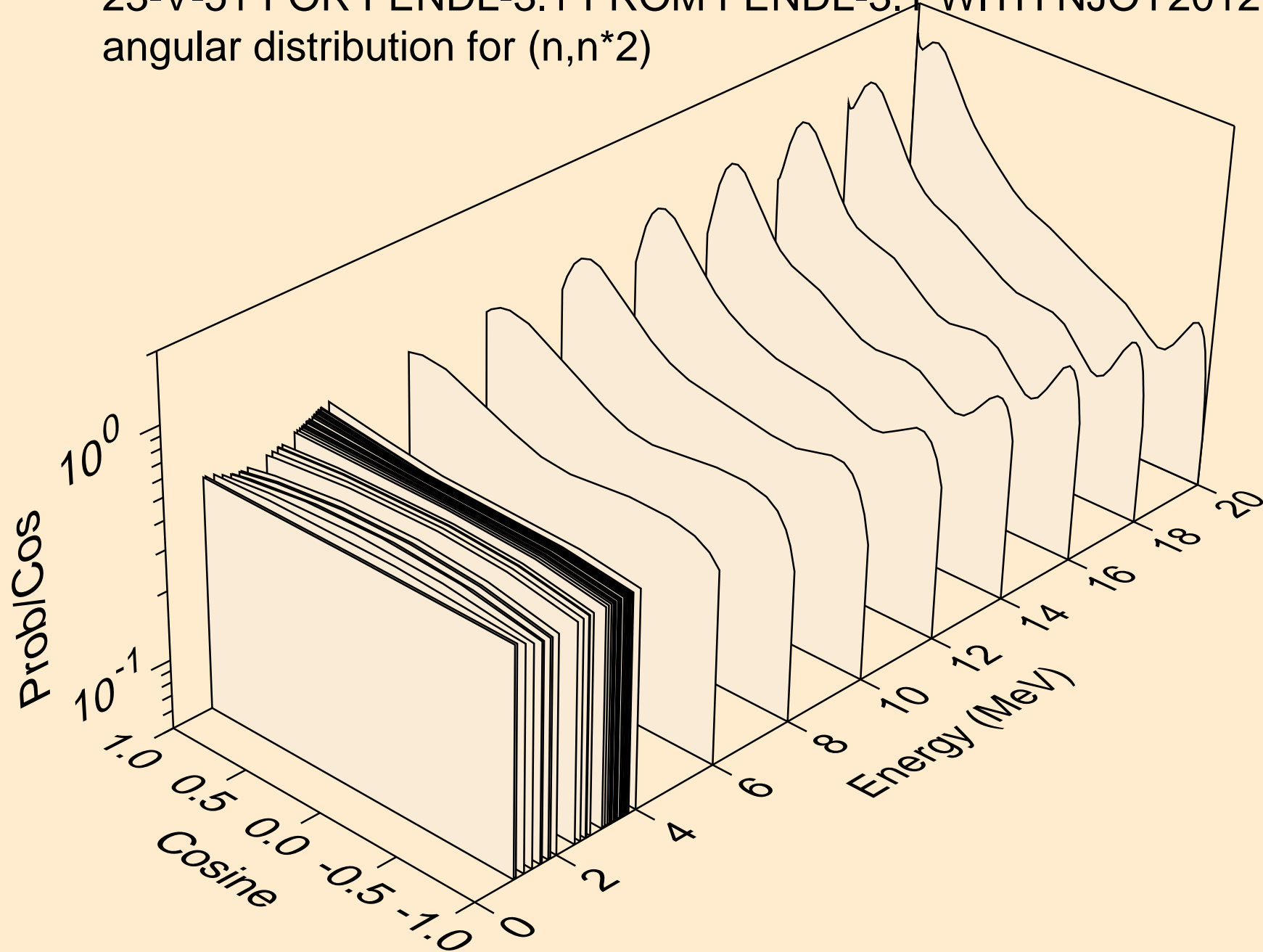

23-V-51 FOR FENDL-3.1 FROM FENDL-3.1 WITH NJOY2012.50+ C
angular distribution for (n,n*3)

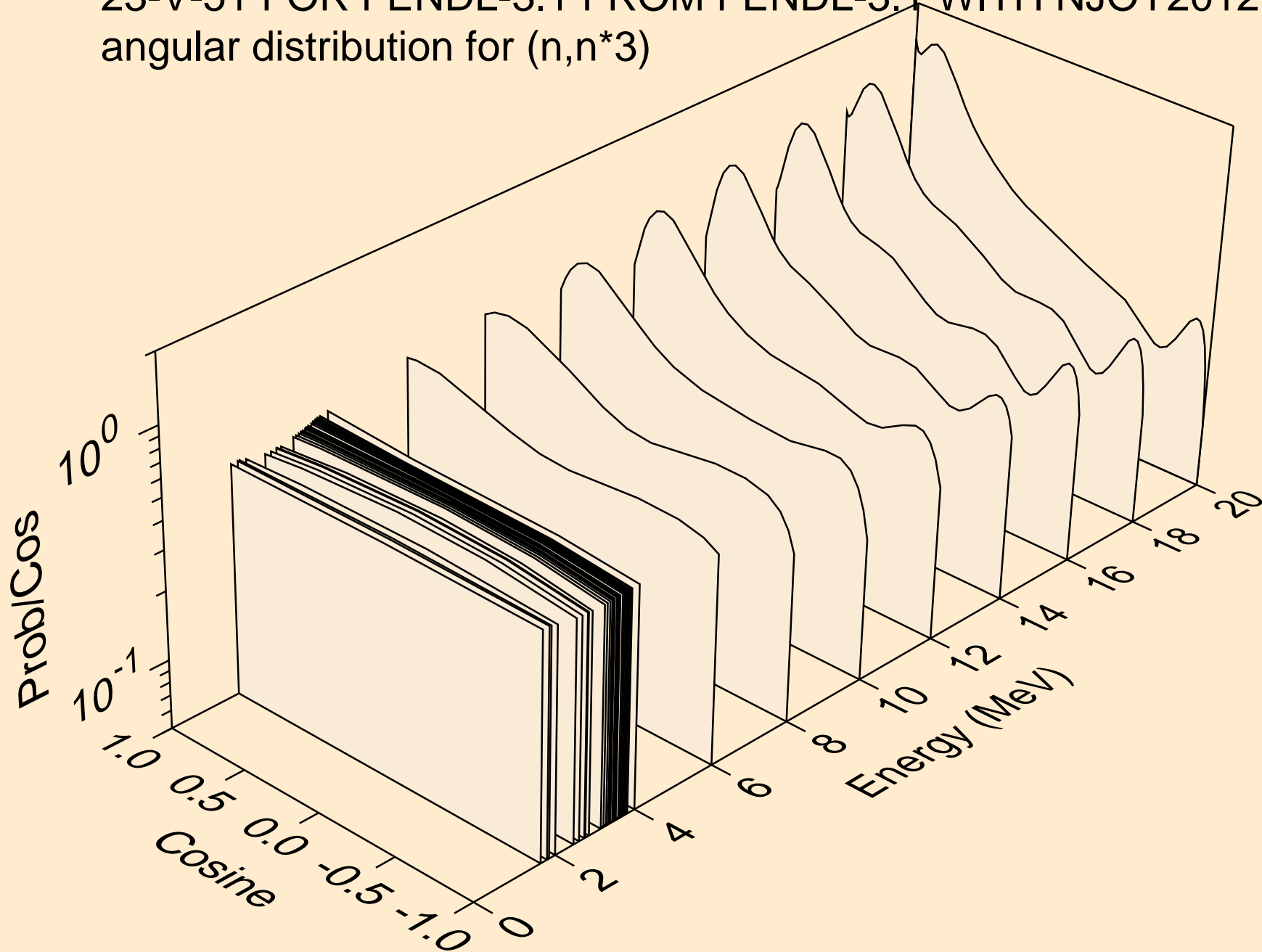

23-V-51 FOR FENDL-3.1 FROM FENDL-3.1 WITH NJOY2012.50+ C
angular distribution for (n,n*4)

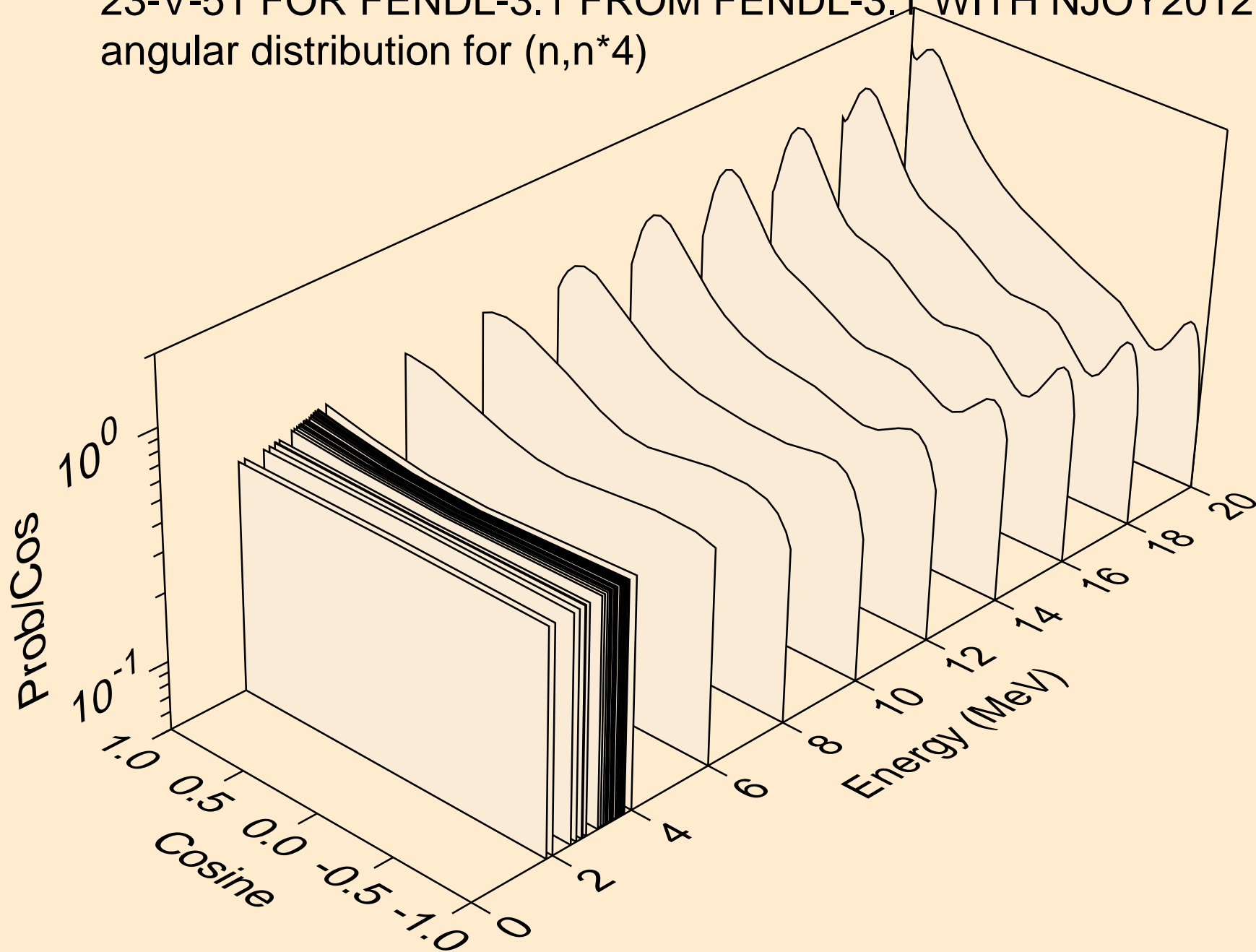

23-V-51 FOR FENDL-3.1 FROM FENDL-3.1 WITH NJOY2012.50+ C
angular distribution for (n,n*5)

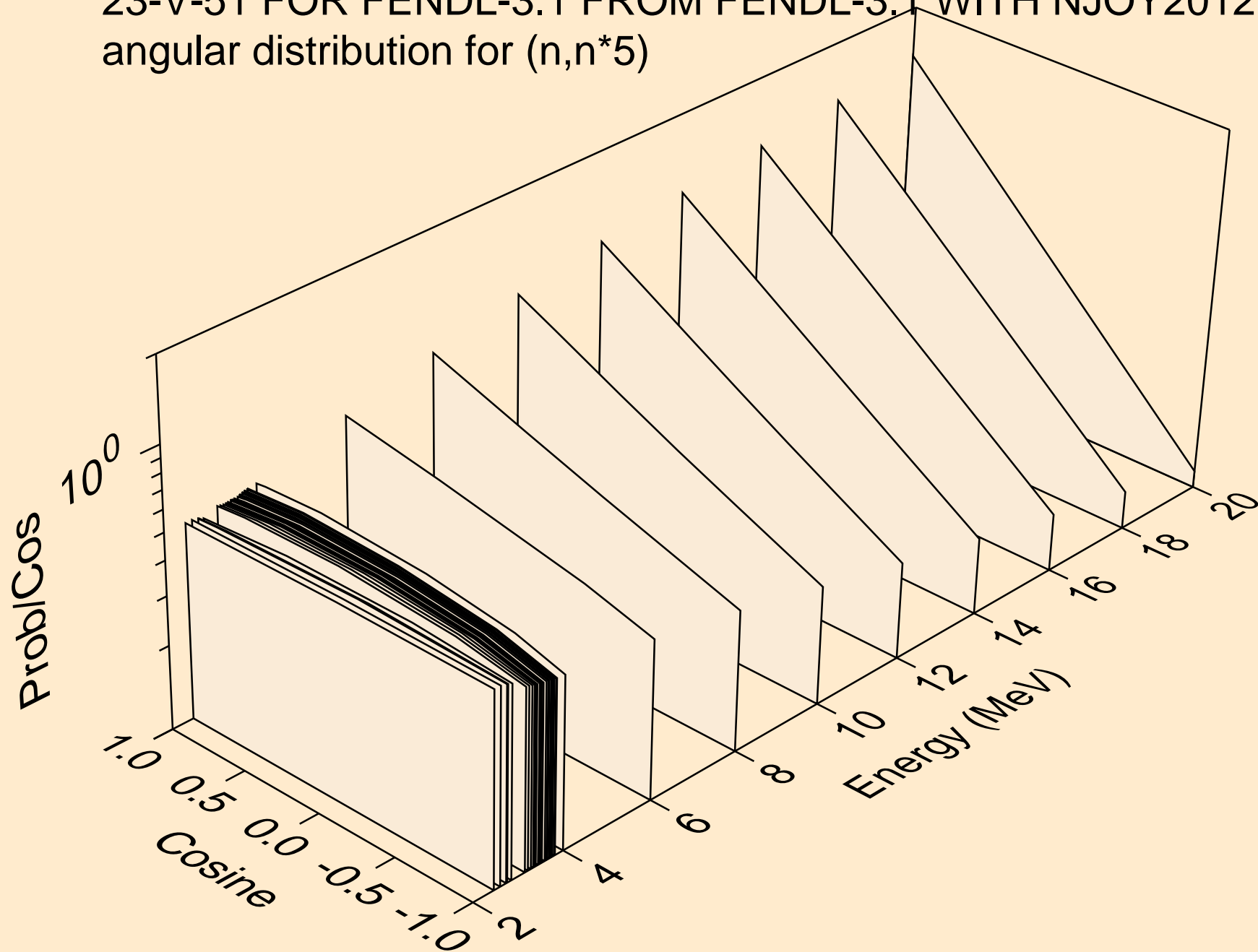

23-V-51 FOR FENDL-3.1 FROM FENDL-3.1 WITH NJOY2012.50+ C
angular distribution for (n,n*6)

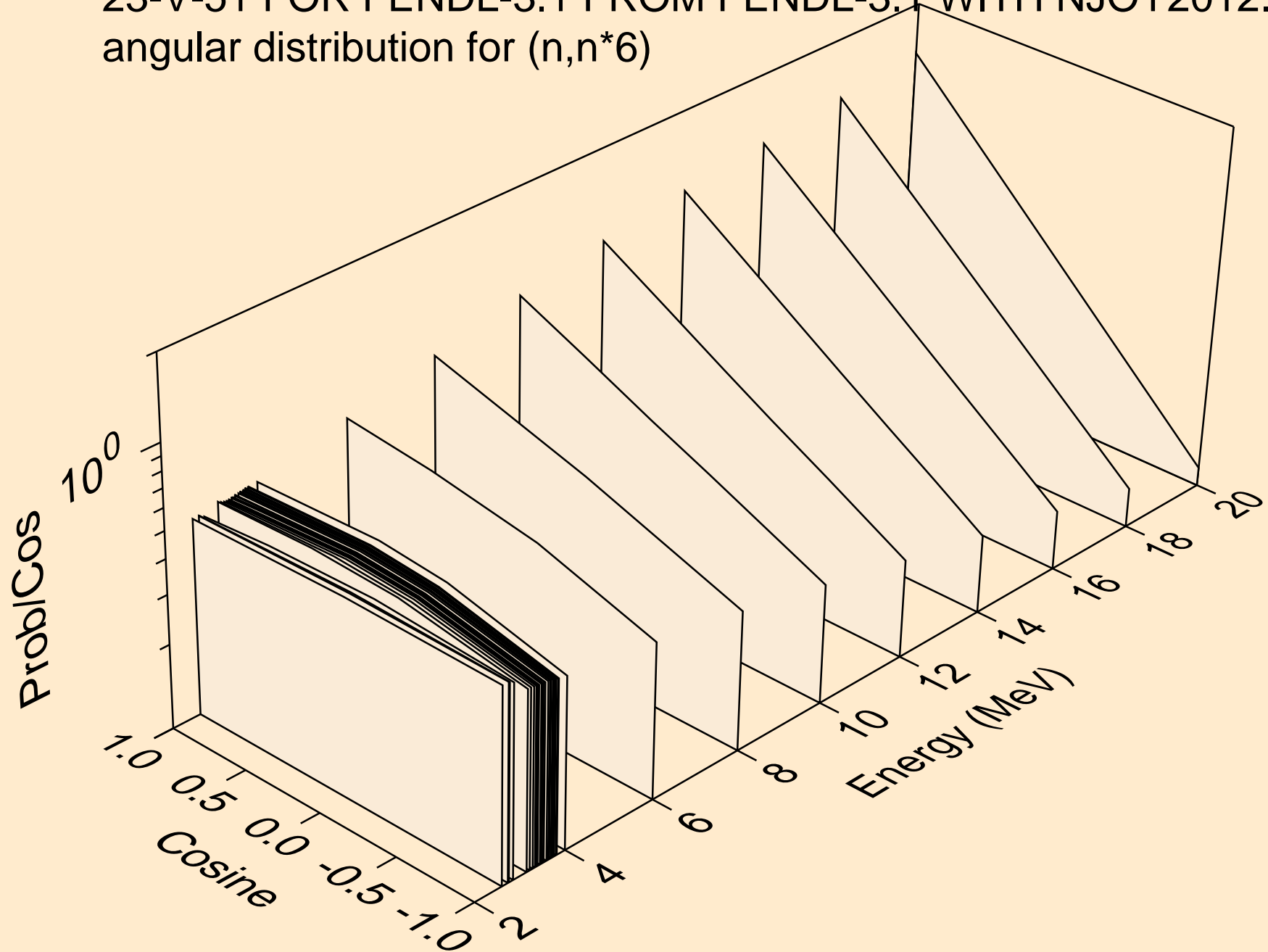

23-V-51 FOR FENDL-3.1 FROM FENDL-3.1 WITH NJOY2012.50+ C
angular distribution for (n,n*7)

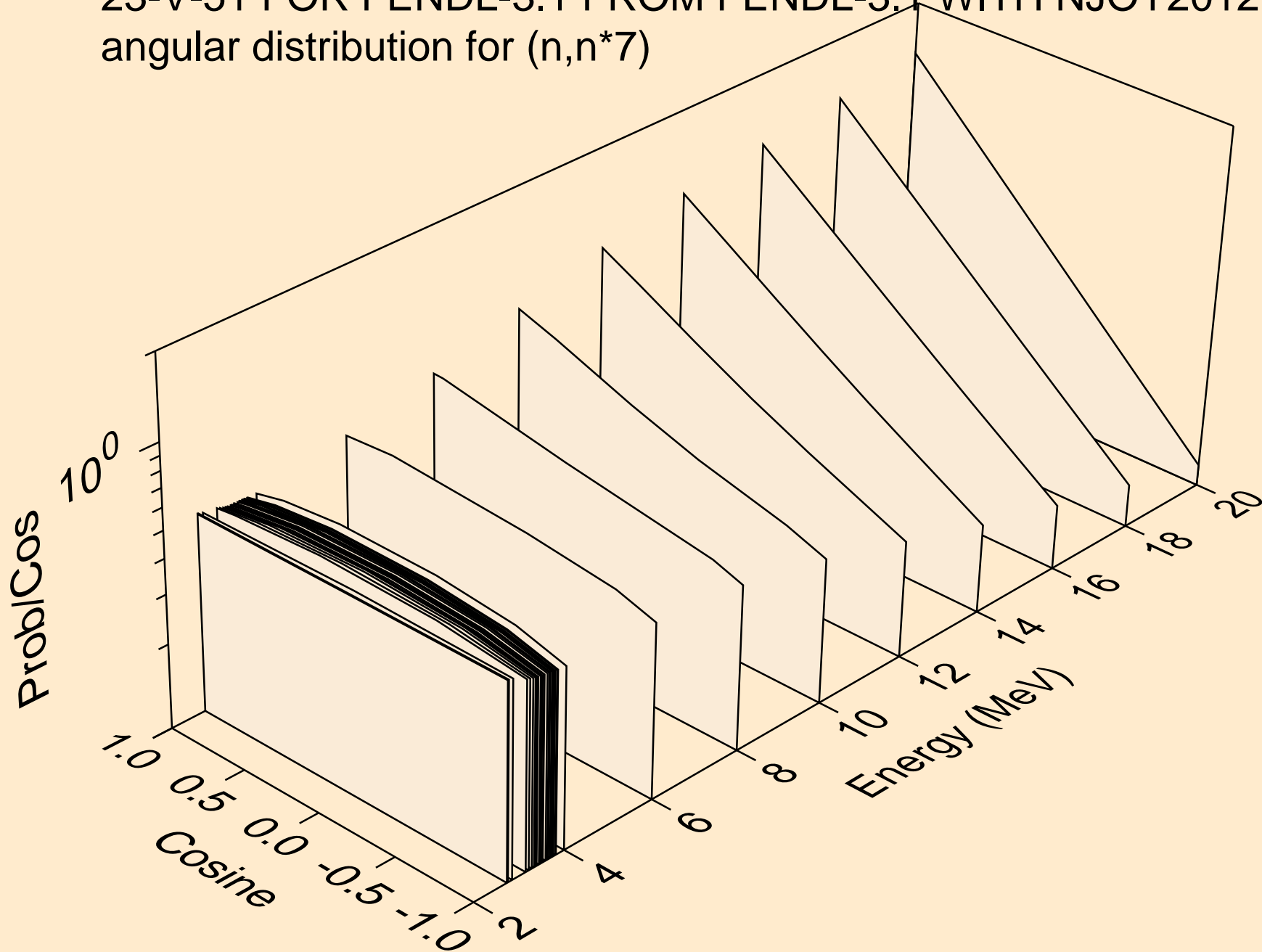

23-V-51 FOR FENDL-3.1 FROM FENDL-3.1 WITH NJOY2012.50+ C
angular distribution for (n,n*8)

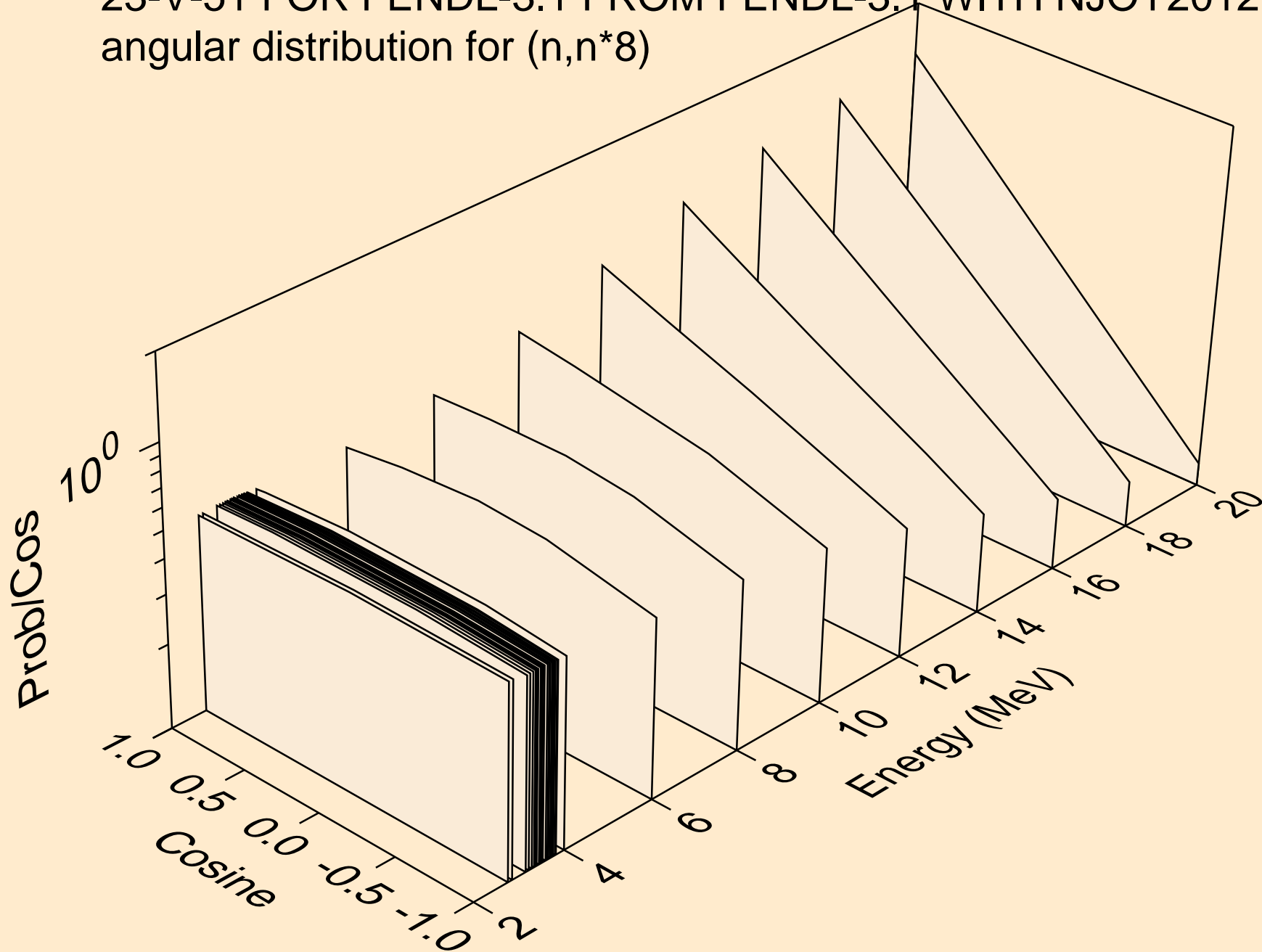

23-V-51 FOR FENDL-3.1 FROM FENDL-3.1 WITH NJOY2012.50+ C
angular distribution for (n,n*9)

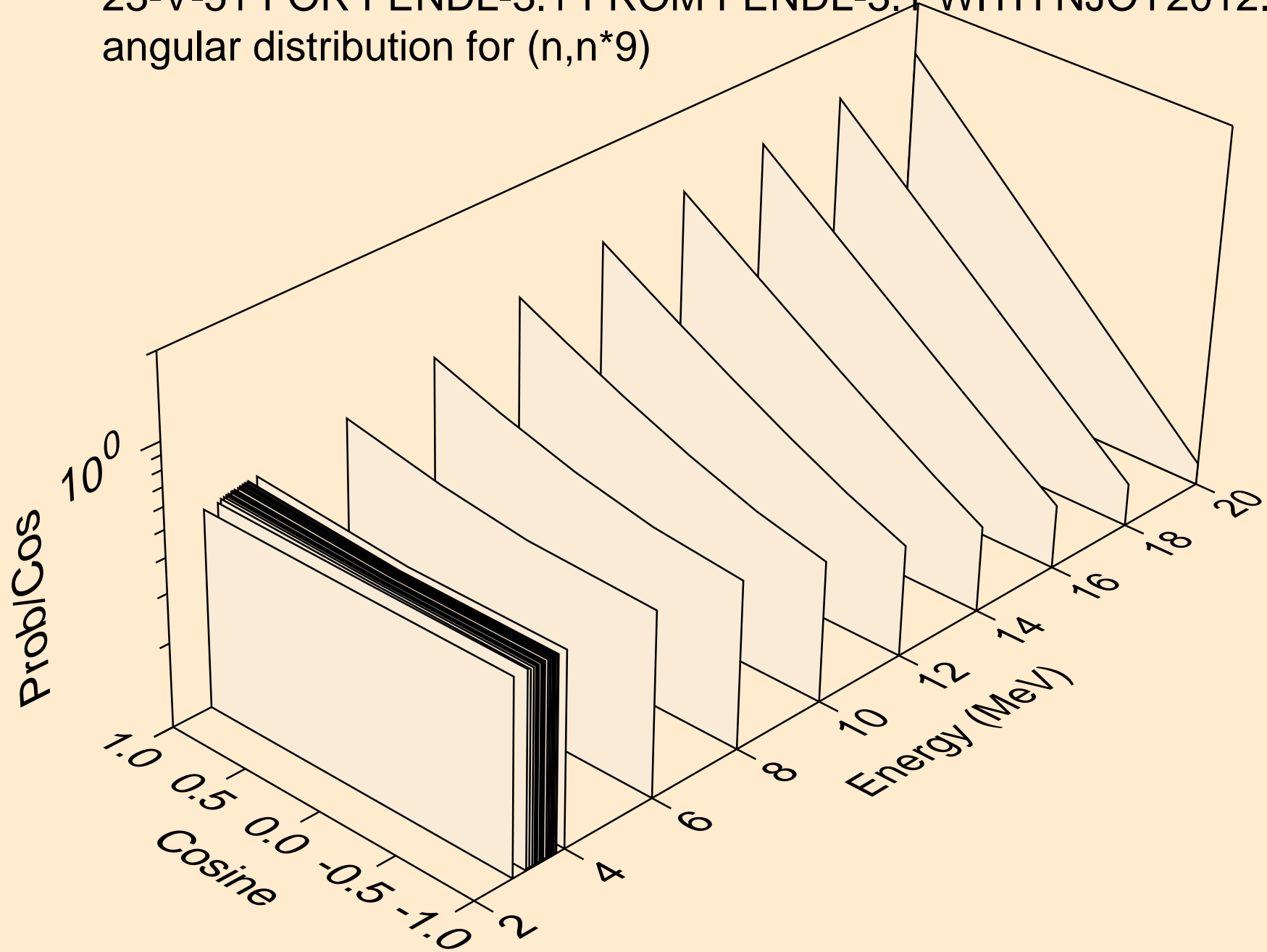

23-V-51 FOR FENDL-3.1 FROM FENDL-3.1 WITH NJOY2012.50+ C
angular distribution for (n,n*10)

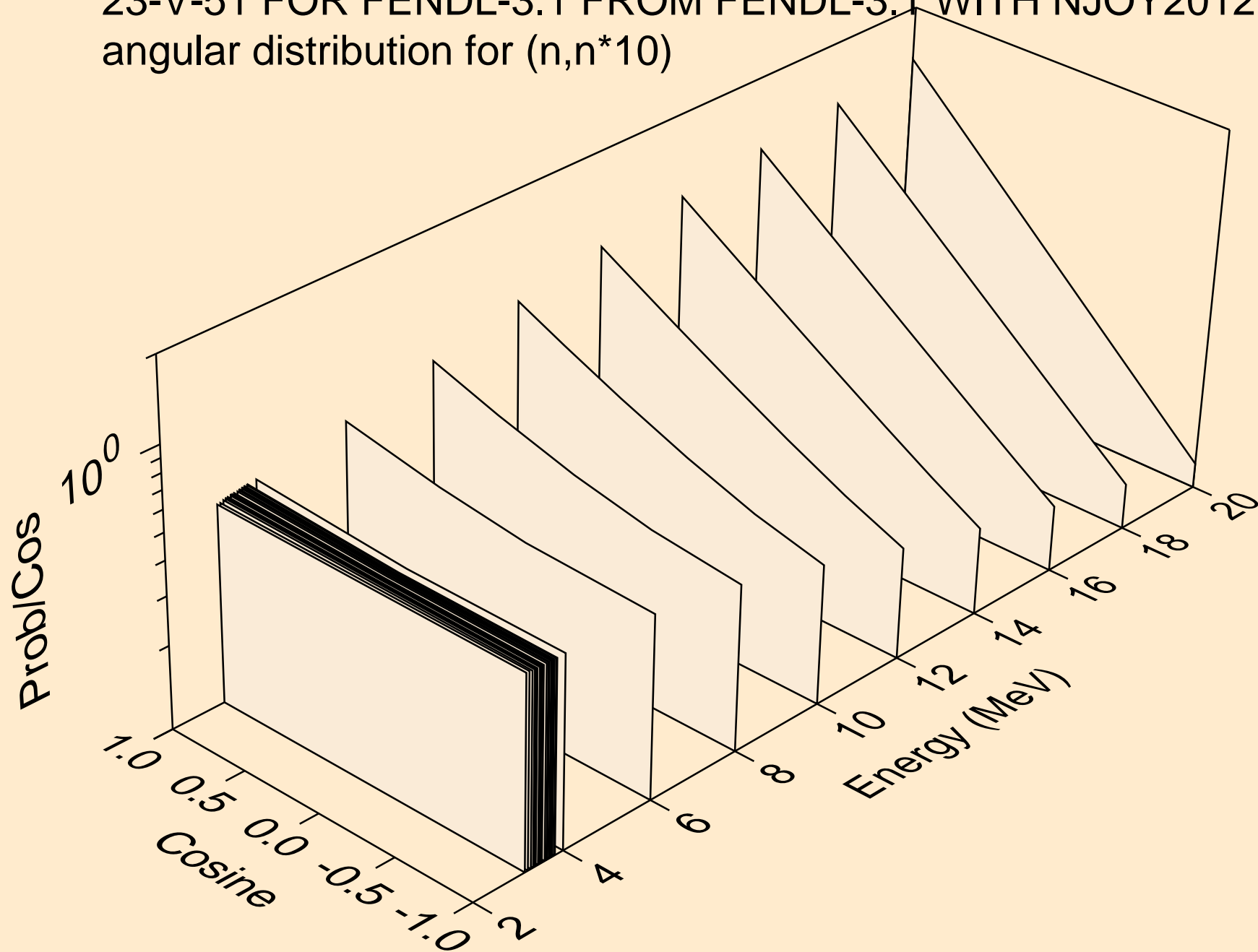

23-V-51 FOR FENDL-3.1 FROM FENDL-3.1 WITH NJOY2012.50+ C
angular distribution for (n,n*11)

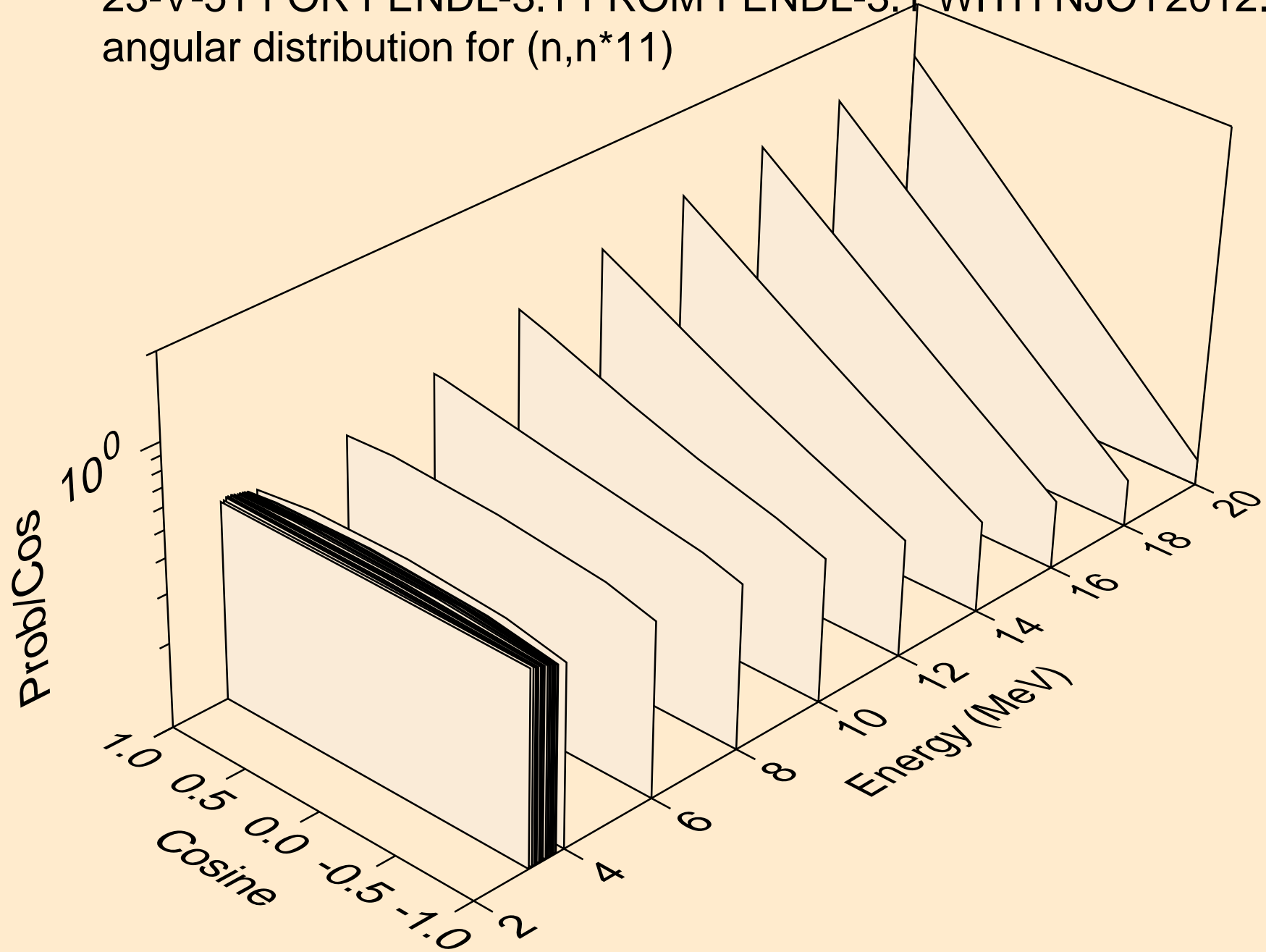

23-V-51 FOR FENDL-3.1 FROM FENDL-3.1 WITH NJOY2012.50+ C
angular distribution for (n,n*12)

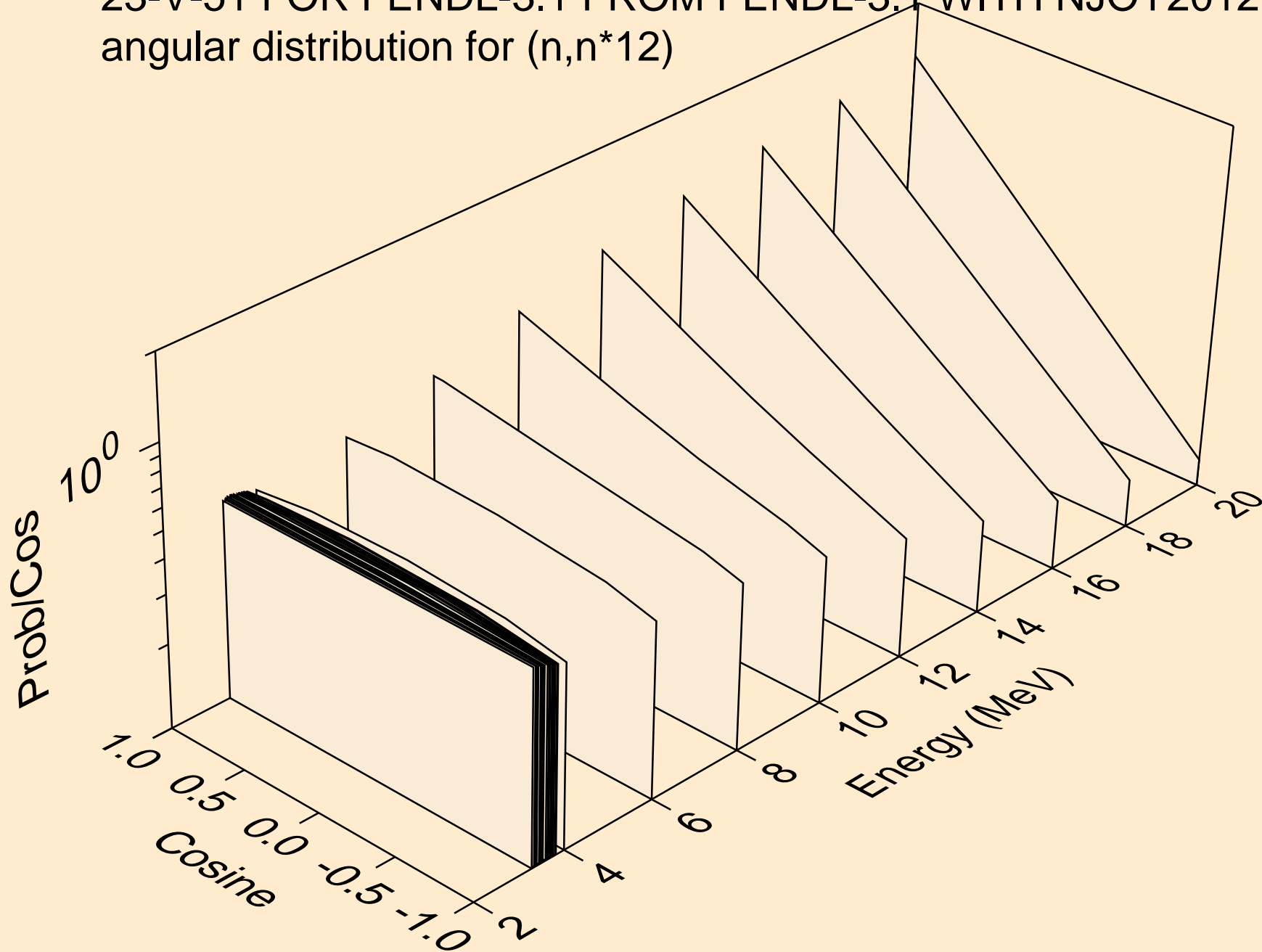

23-V-51 FOR FENDL-3.1 FROM FENDL-3.1 WITH NJOY2012.50+ C
angular distribution for (n,n*13)

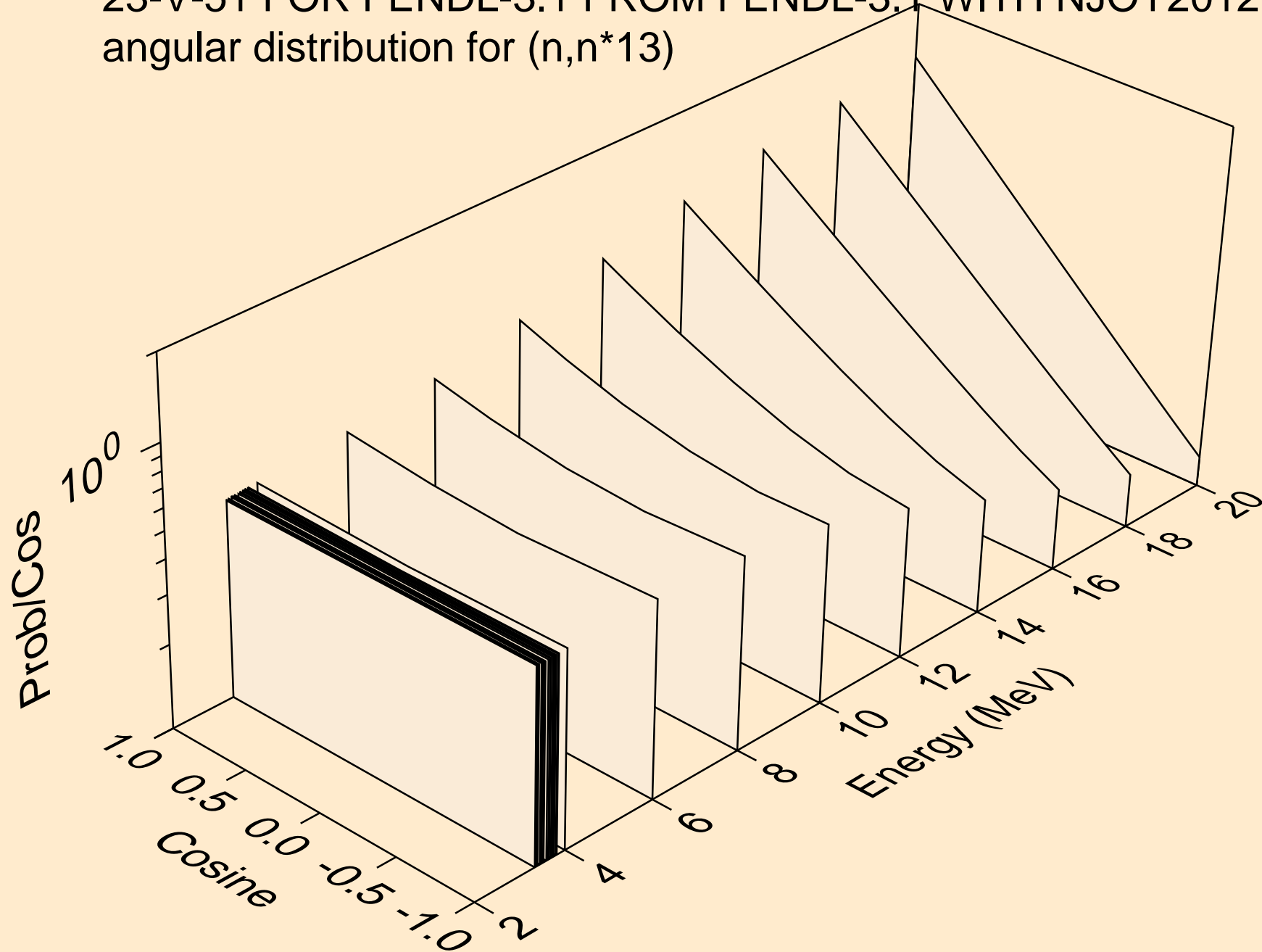

23-V-51 FOR FENDL-3.1 FROM FENDL-3.1 WITH NJOY2012.50+ C
angular distribution for (n,n*14)

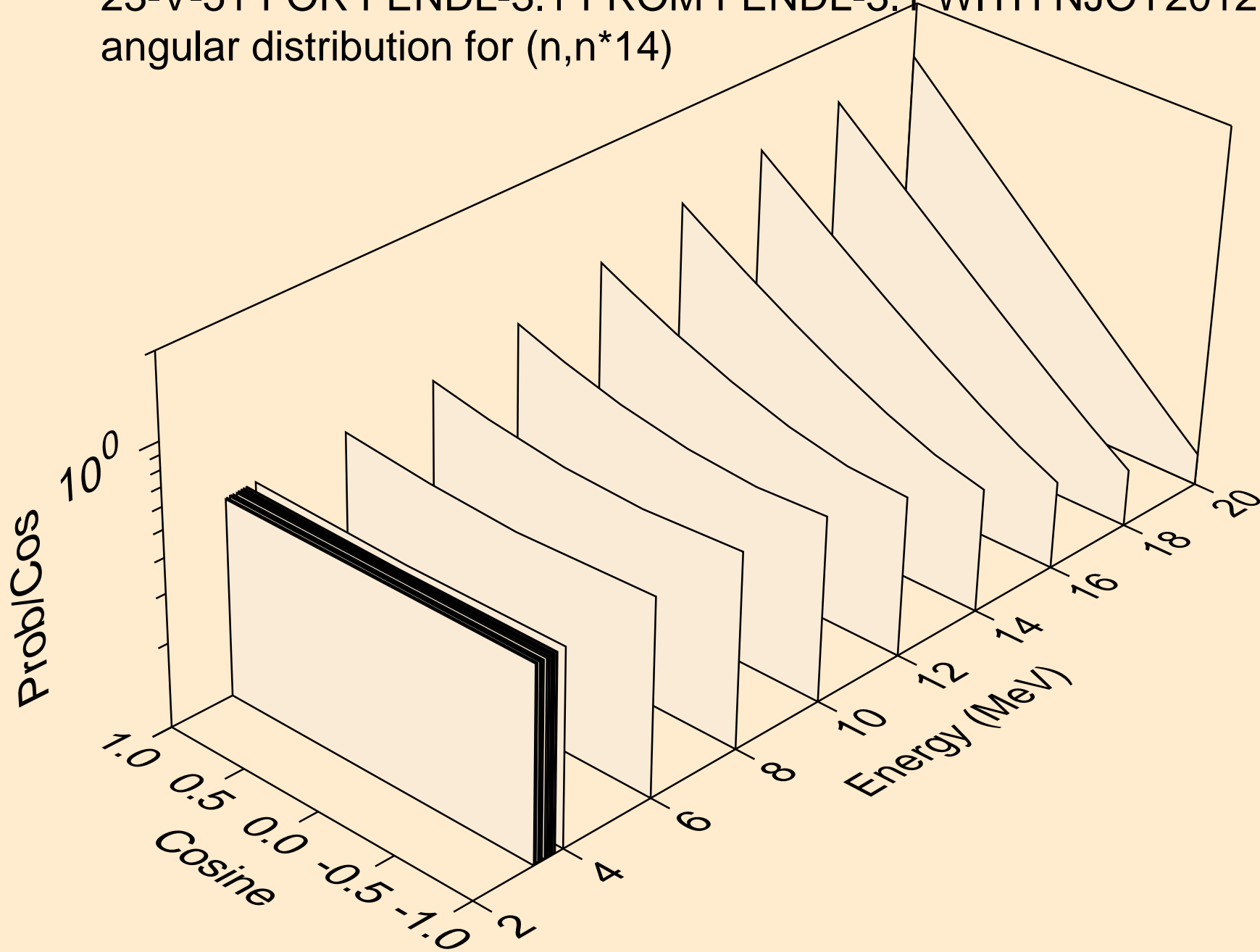

23-V-51 FOR FENDL-3.1 FROM FENDL-3.1 WITH NJOY2012.50+ C
angular distribution for (n,n*15)

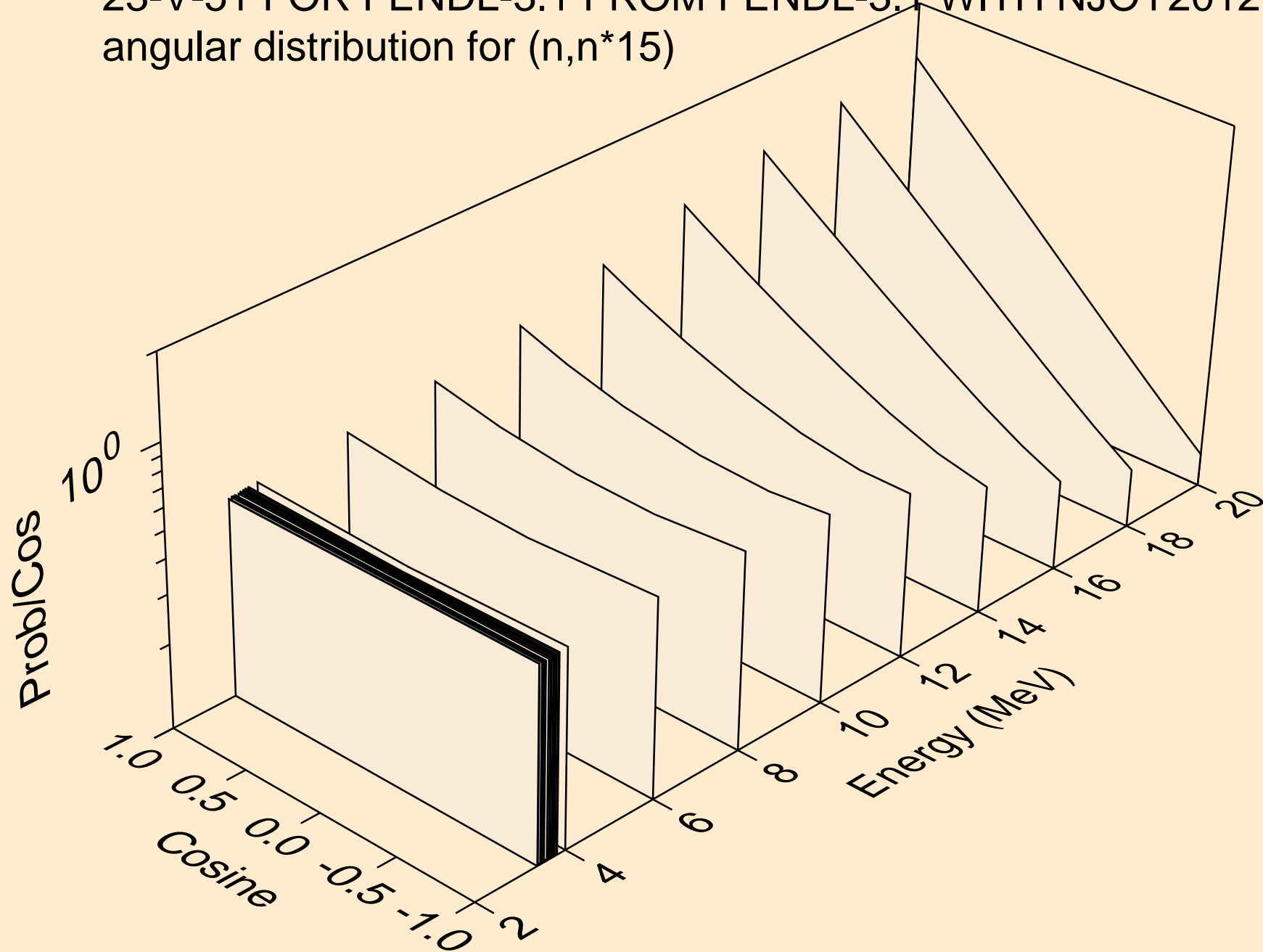

23-V-51 FOR FENDL-3.1 FROM FENDL-3.1 WITH NJOY2012.50+ C
angular distribution for (n,n*16)

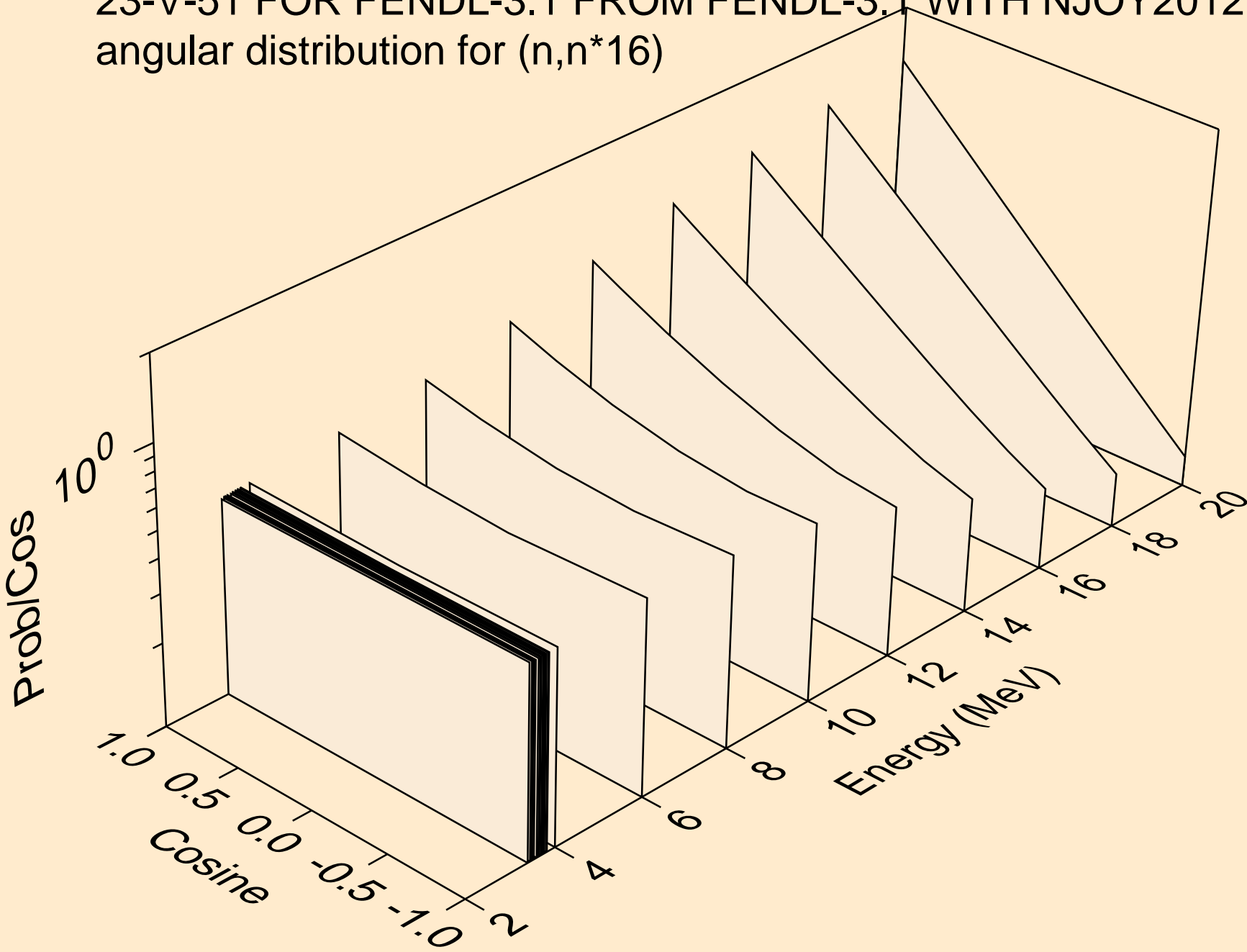

23-V-51 FOR FENDL-3.1 FROM FENDL-3.1 WITH NJOY2012.50+ C
angular distribution for (n,n*17)

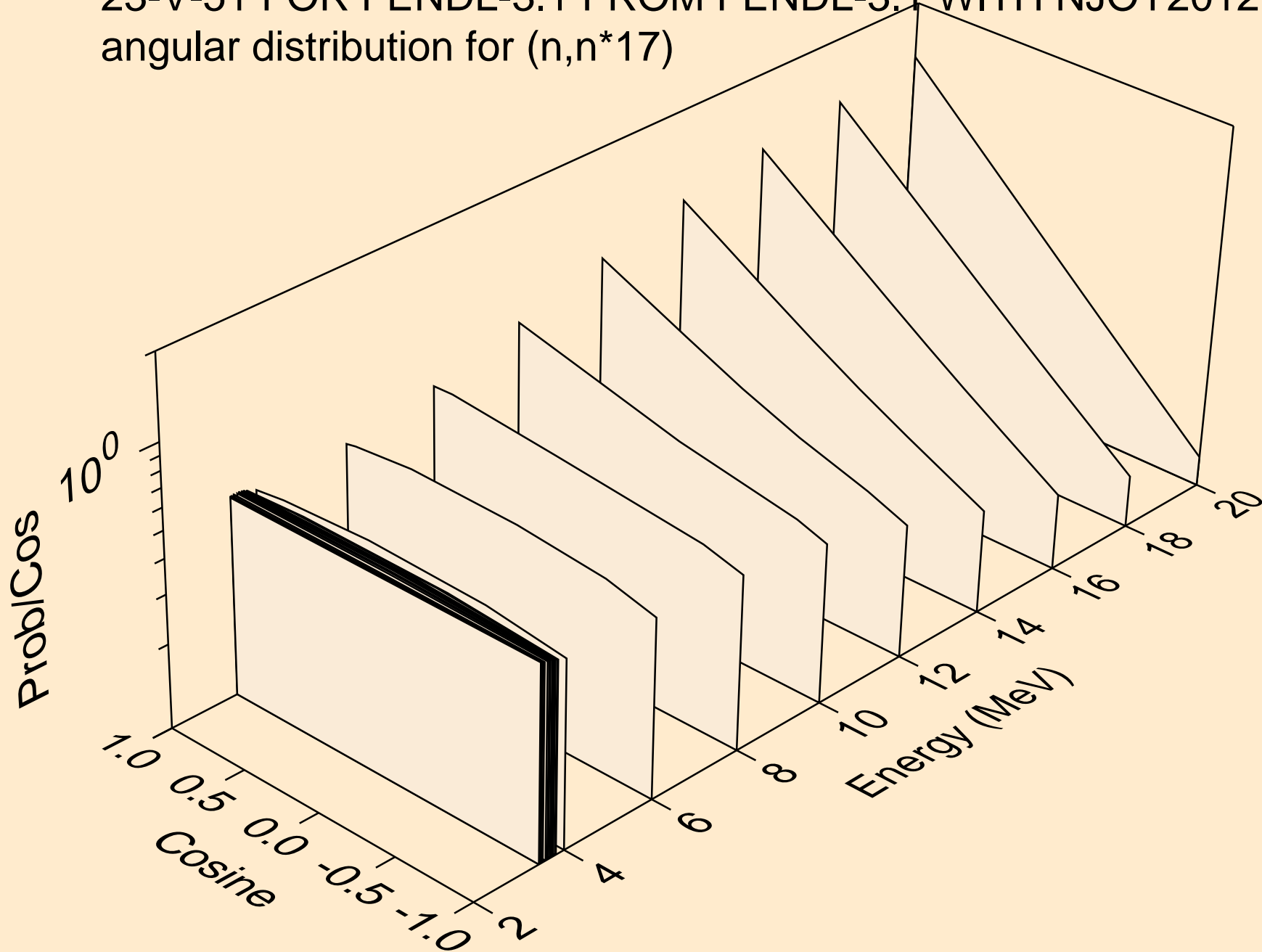

23-V-51 FOR FENDL-3.1 FROM FENDL-3.1 WITH NJOY2012.50+ C
angular distribution for (n,n*18)

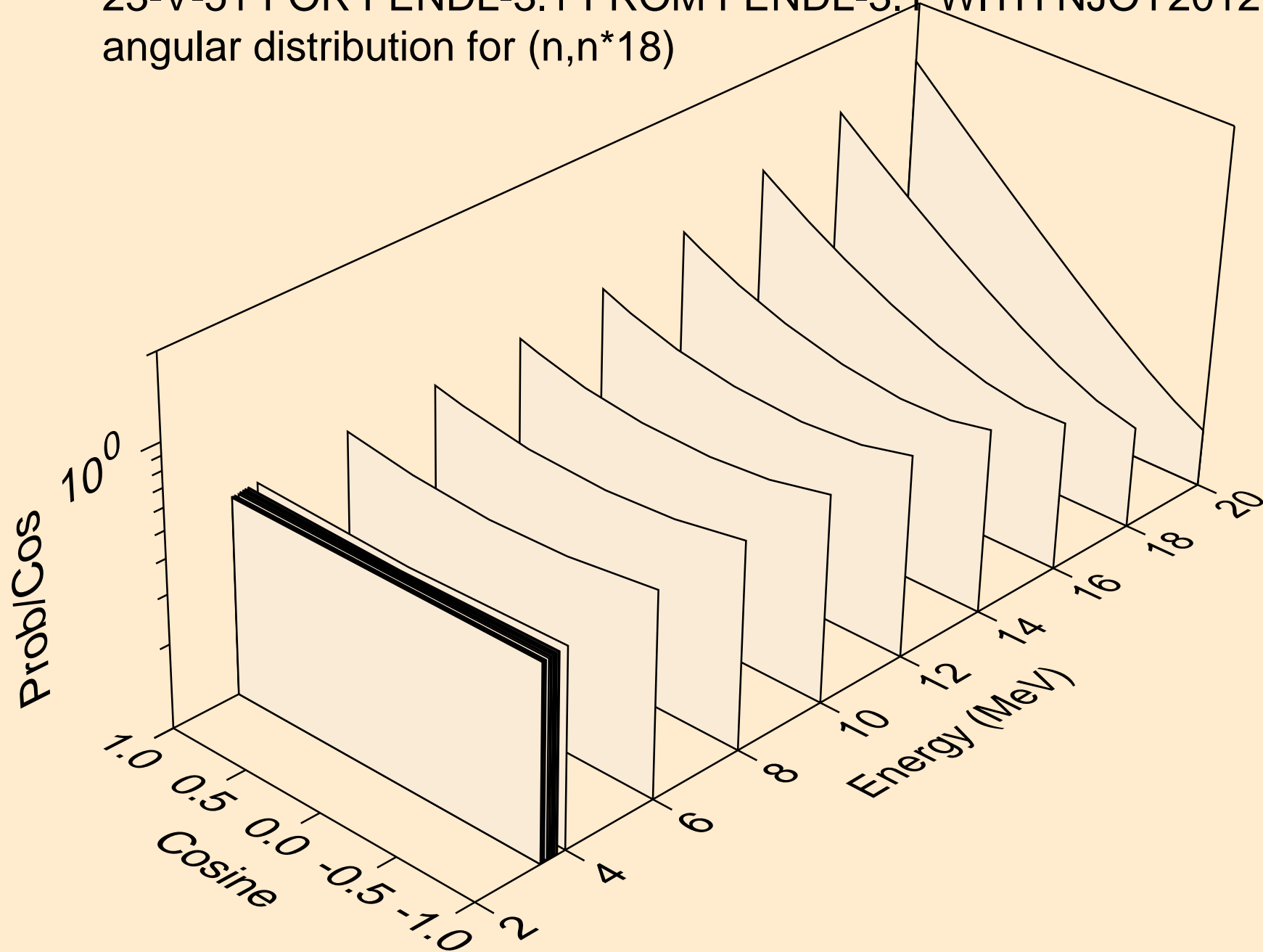

23-V-51 FOR FENDL-3.1 FROM FENDL-3.1 WITH NJOY2012.50+ C
angular distribution for (n,n*19)

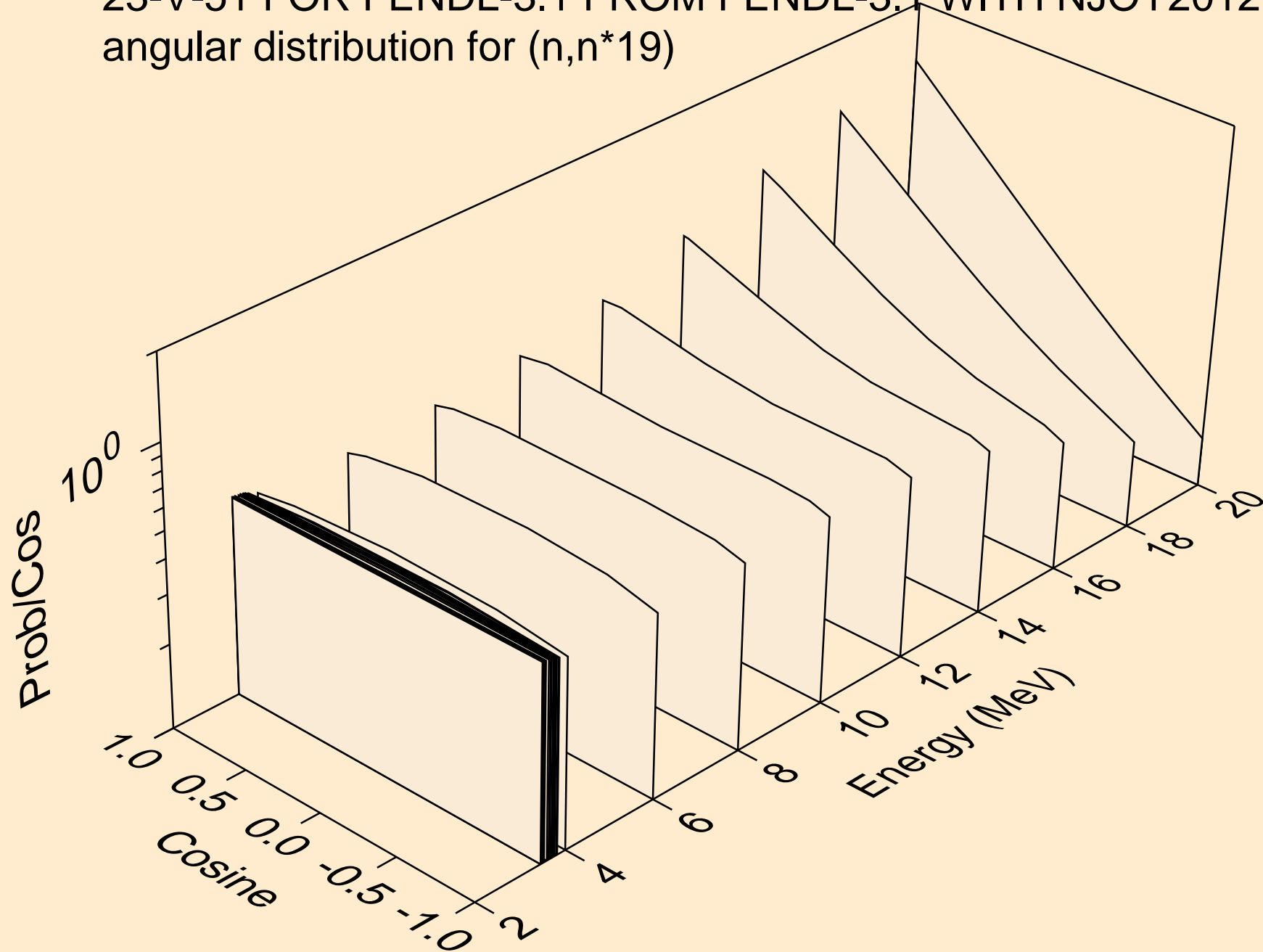

23-V-51 FOR FENDL-3.1 FROM FENDL-3.1 WITH NJOY2012.50+ C
angular distribution for (n,n*20)

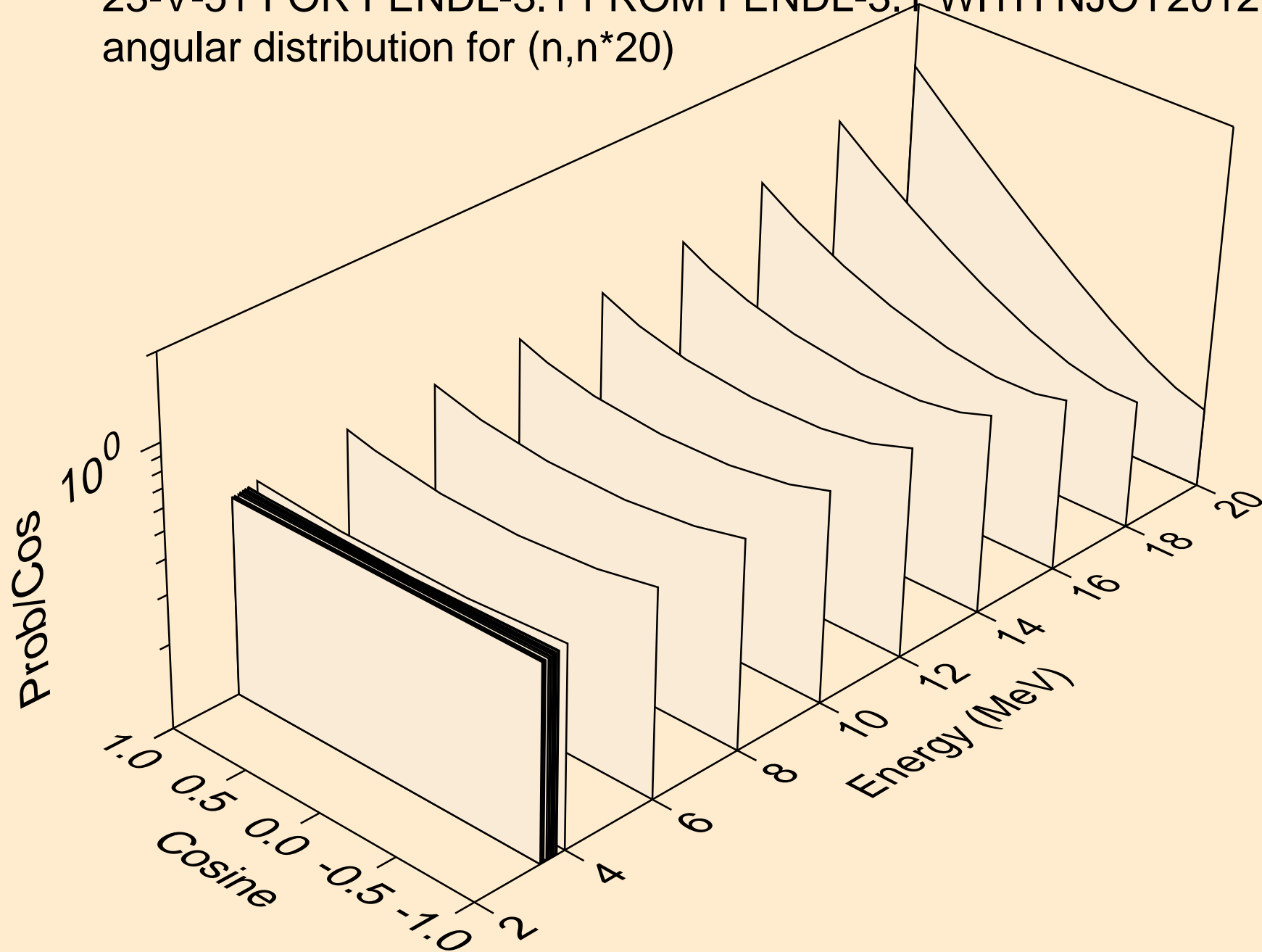

23-V-51 FOR FENDL-3.1 FROM FENDL-3.1 WITH NJOY2012.50+ C
angular distribution for (n,n*21)

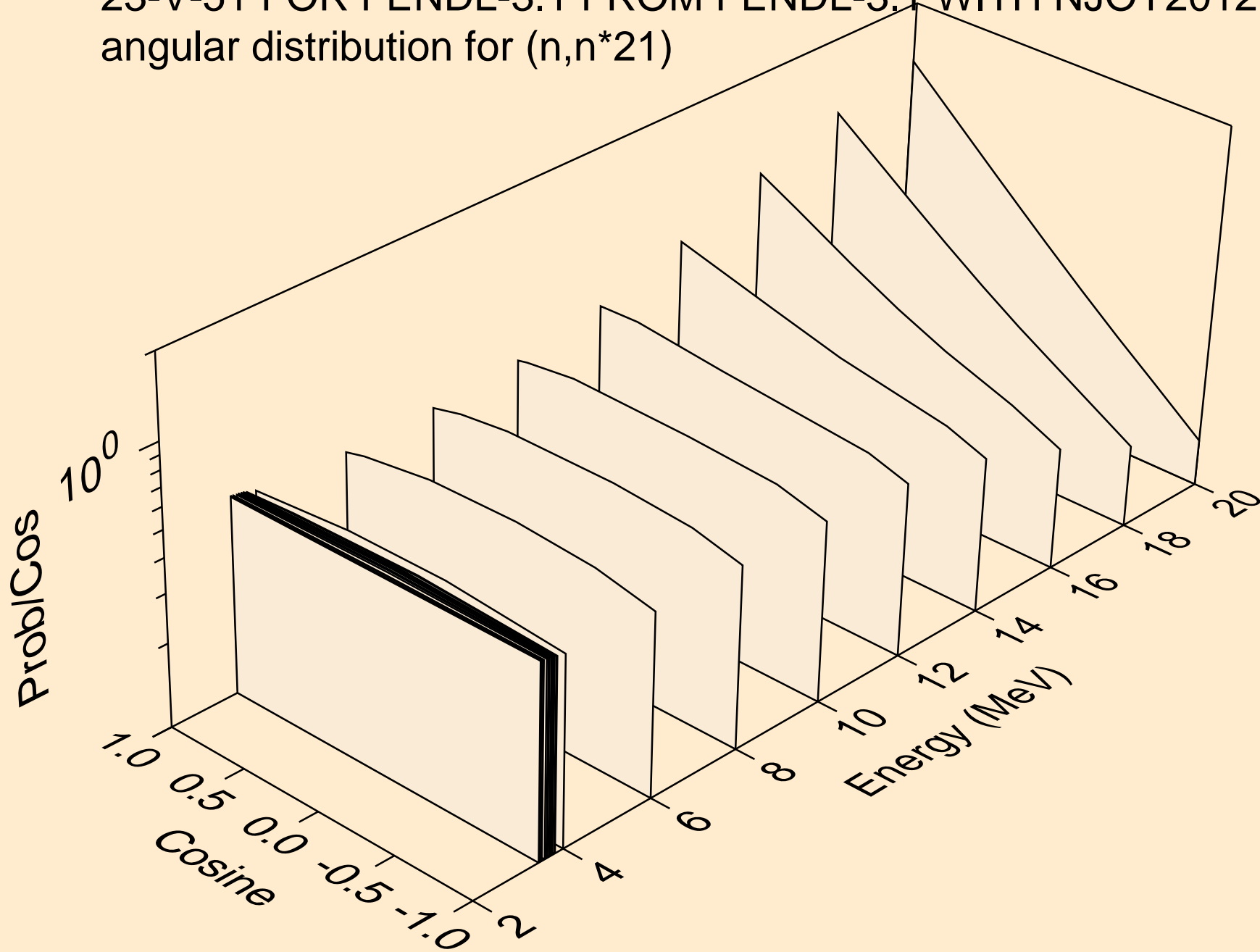

23-V-51 FOR FENDL-3.1 FROM FENDL-3.1 WITH NJOY2012.50+ C
angular distribution for (n,n*22)

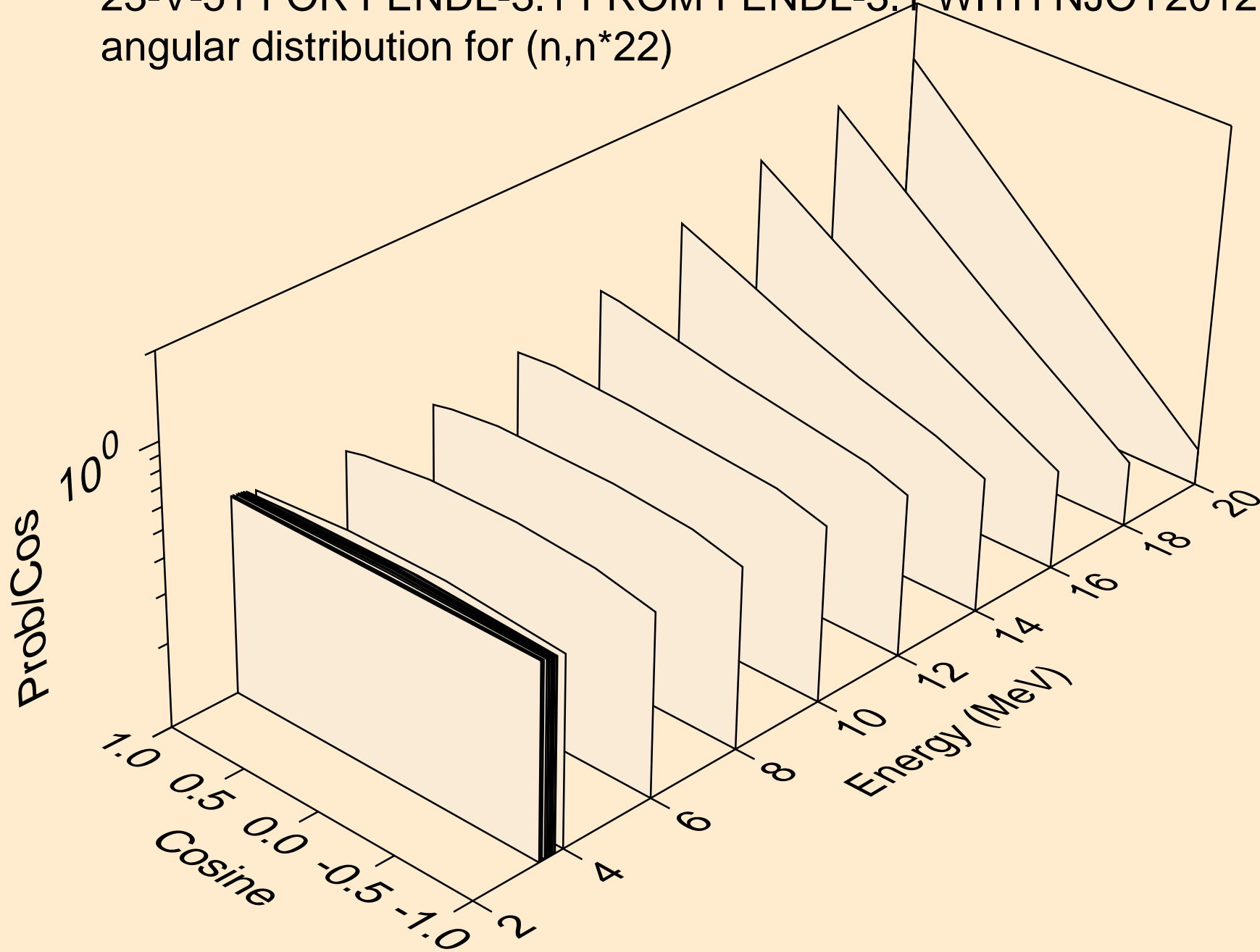

23-V-51 FOR FENDL-3.1 FROM FENDL-3.1 WITH NJOY2012.50+ C
angular distribution for (n,n*23)

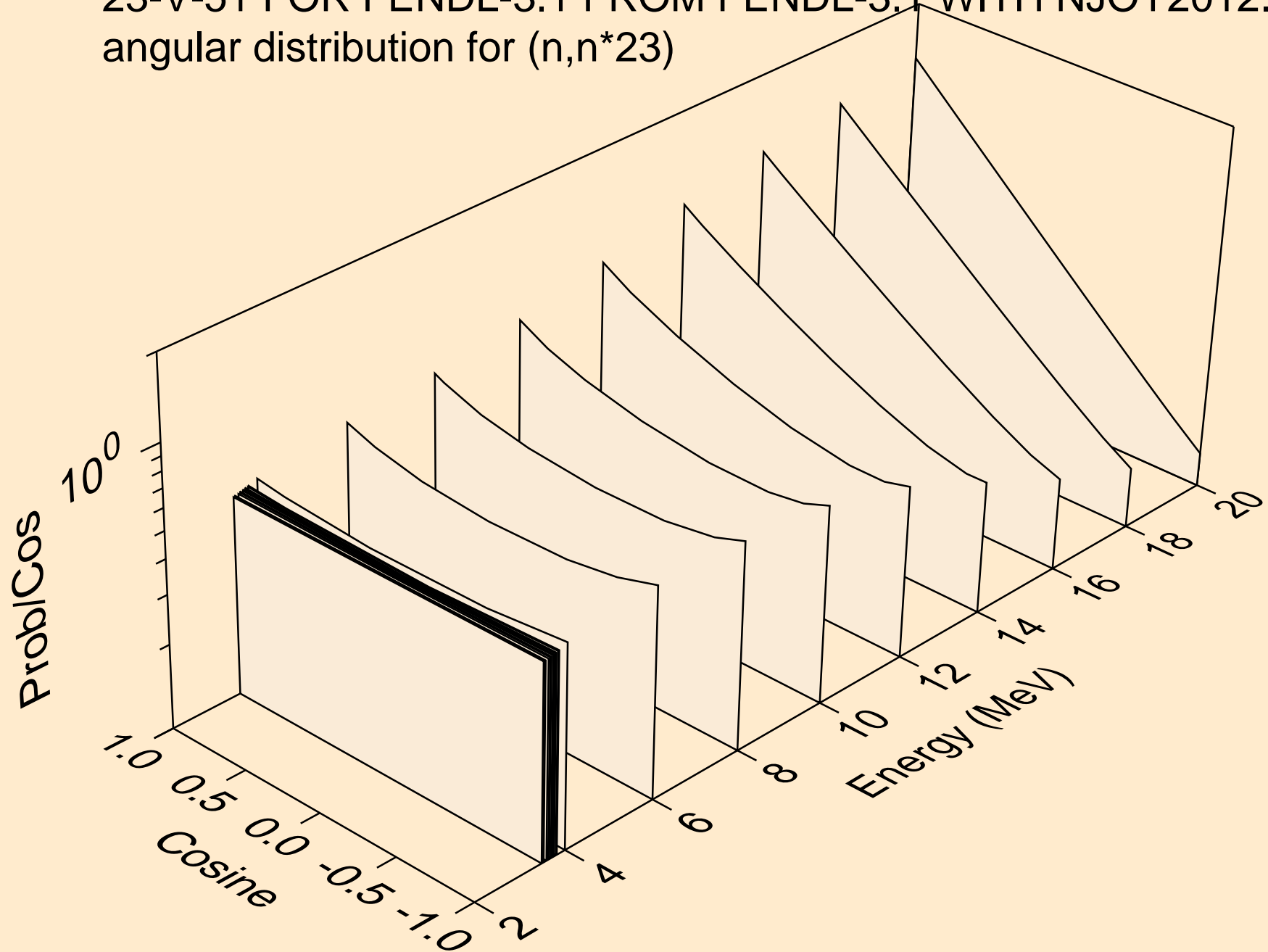

23-V-51 FOR FENDL-3.1 FROM FENDL-3.1 WITH NJOY2012.50+ C
angular distribution for (n,n*24)

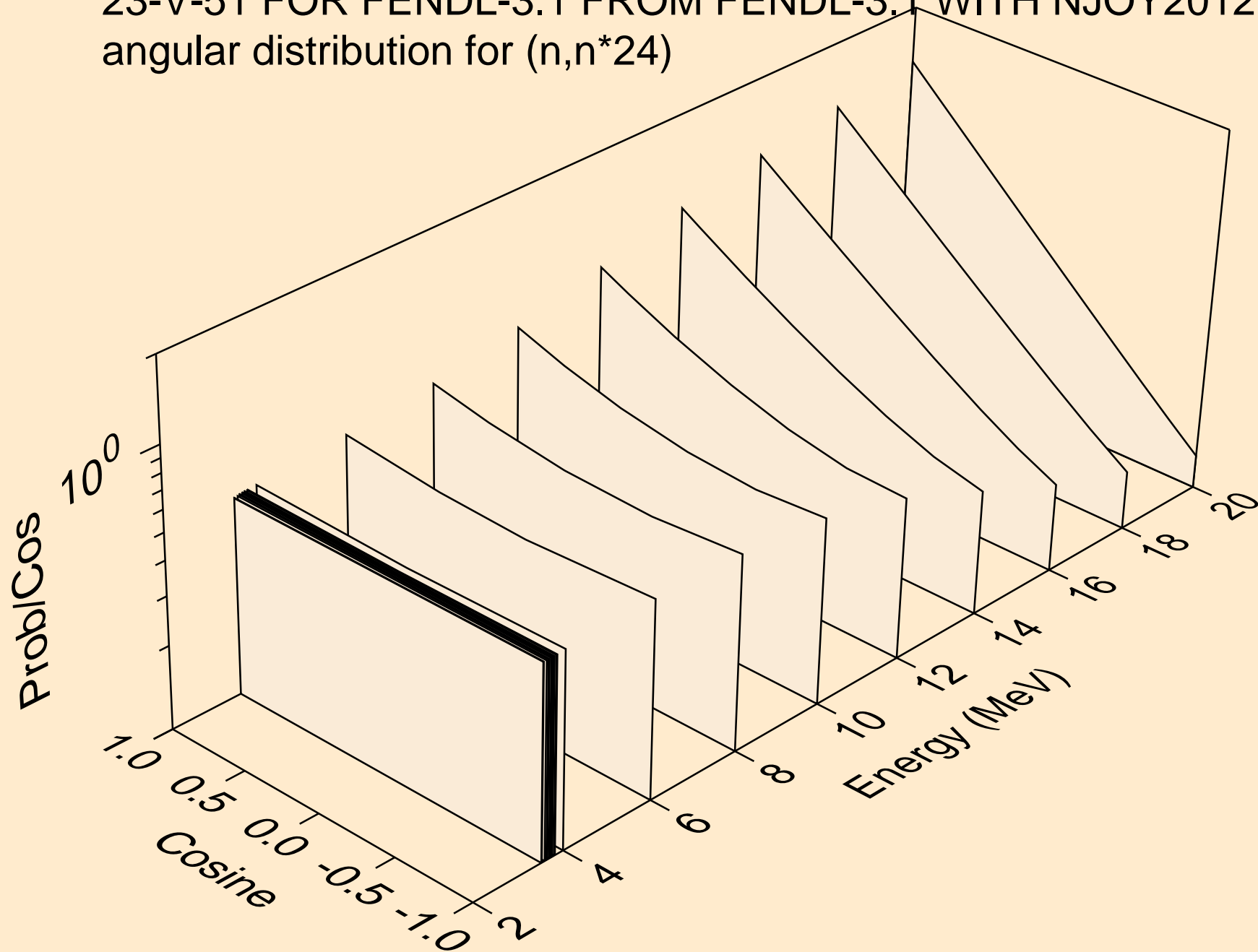

23-V-51 FOR FENDL-3.1 FROM FENDL-3.1 WITH NJOY2012.50+ C
angular distribution for (n,n*25)

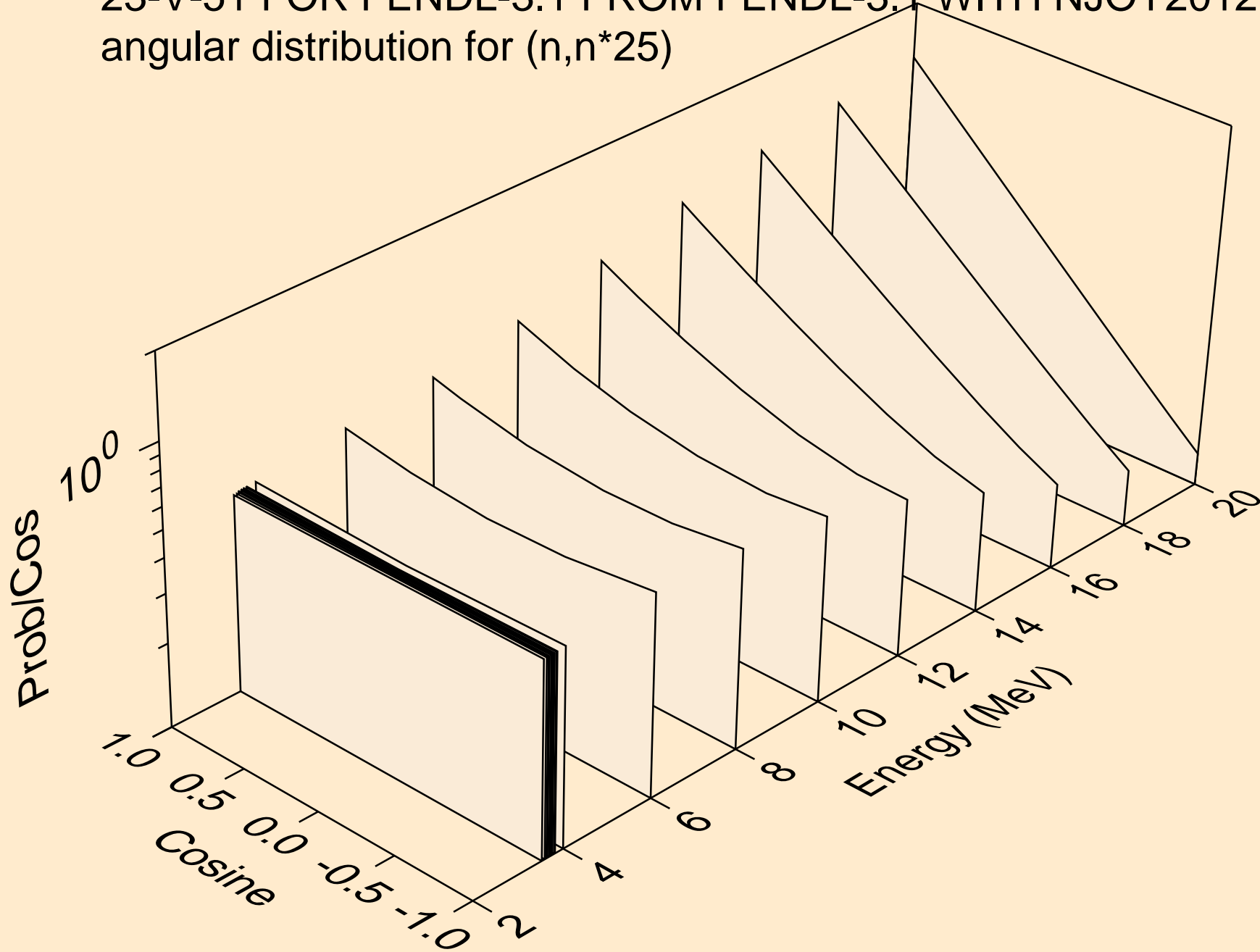

23-V-51 FOR FENDL-3.1 FROM FENDL-3.1 WITH NJOY2012.50+ C
angular distribution for (n,n*26)

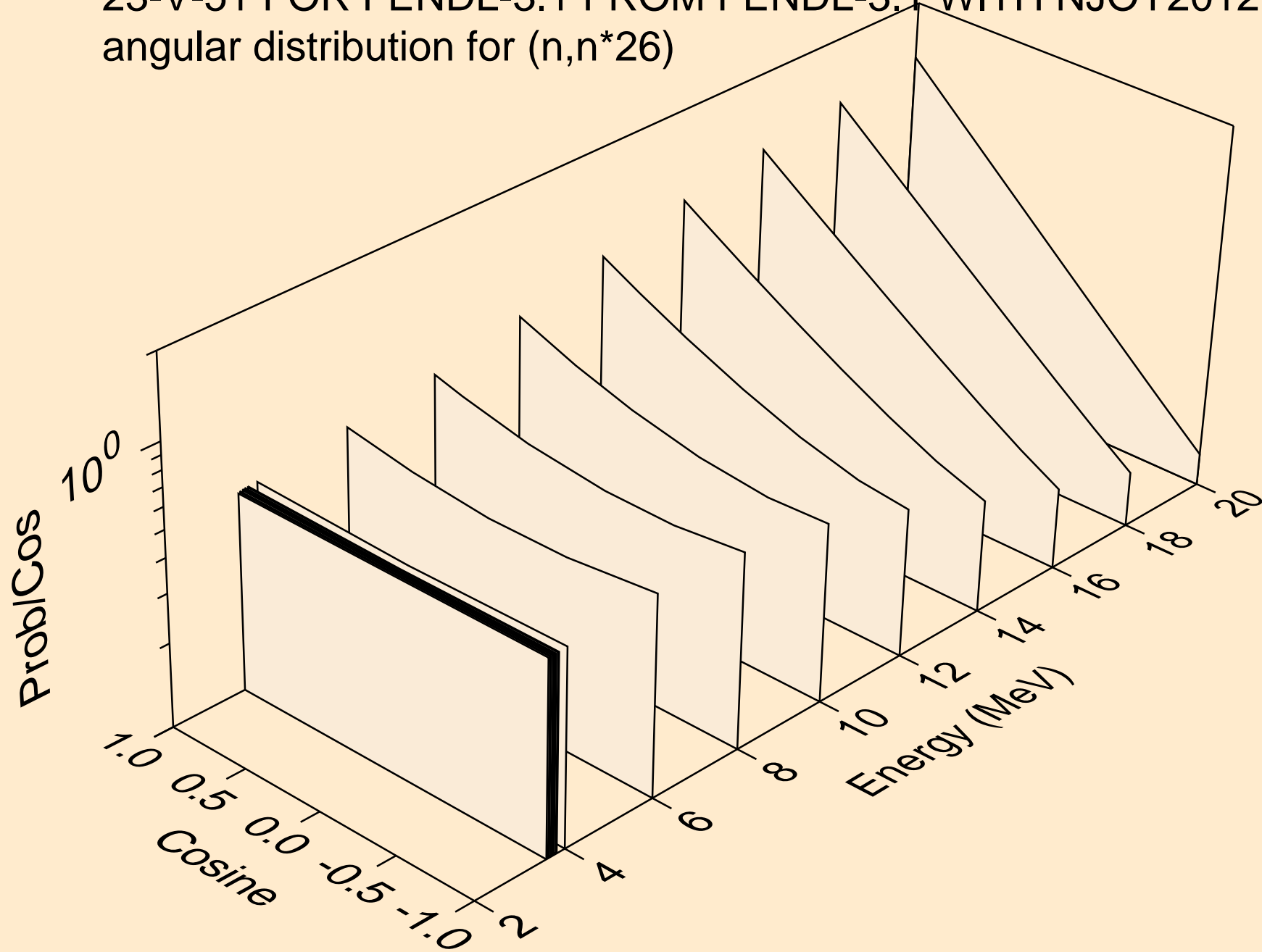

23-V-51 FOR FENDL-3.1 FROM FENDL-3.1 WITH NJOY2012.50+ C
angular distribution for (n,n*27)

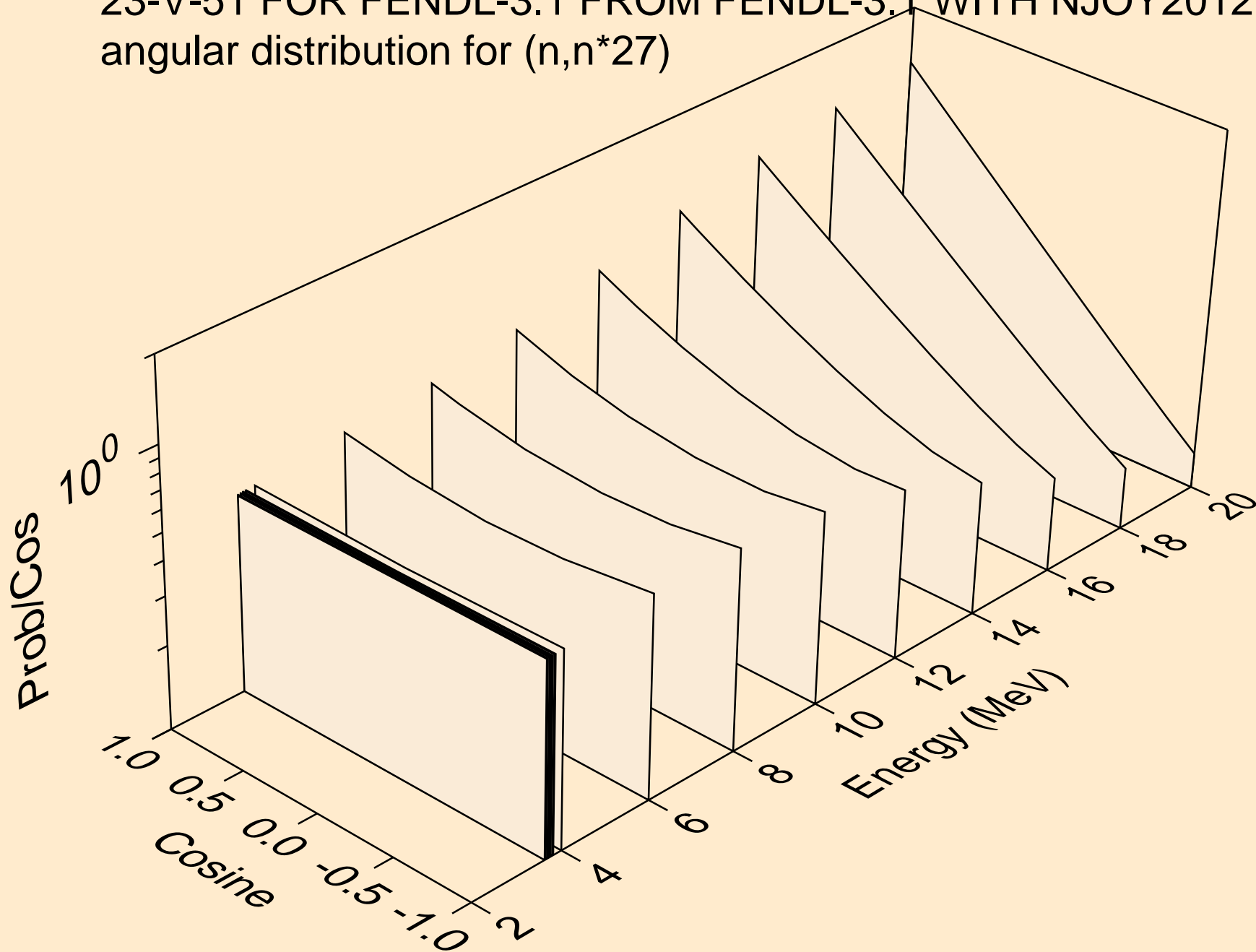

23-V-51 FOR FENDL-3.1 FROM FENDL-3.1 WITH NJOY2012.50+ C
angular distribution for (n,n*28)

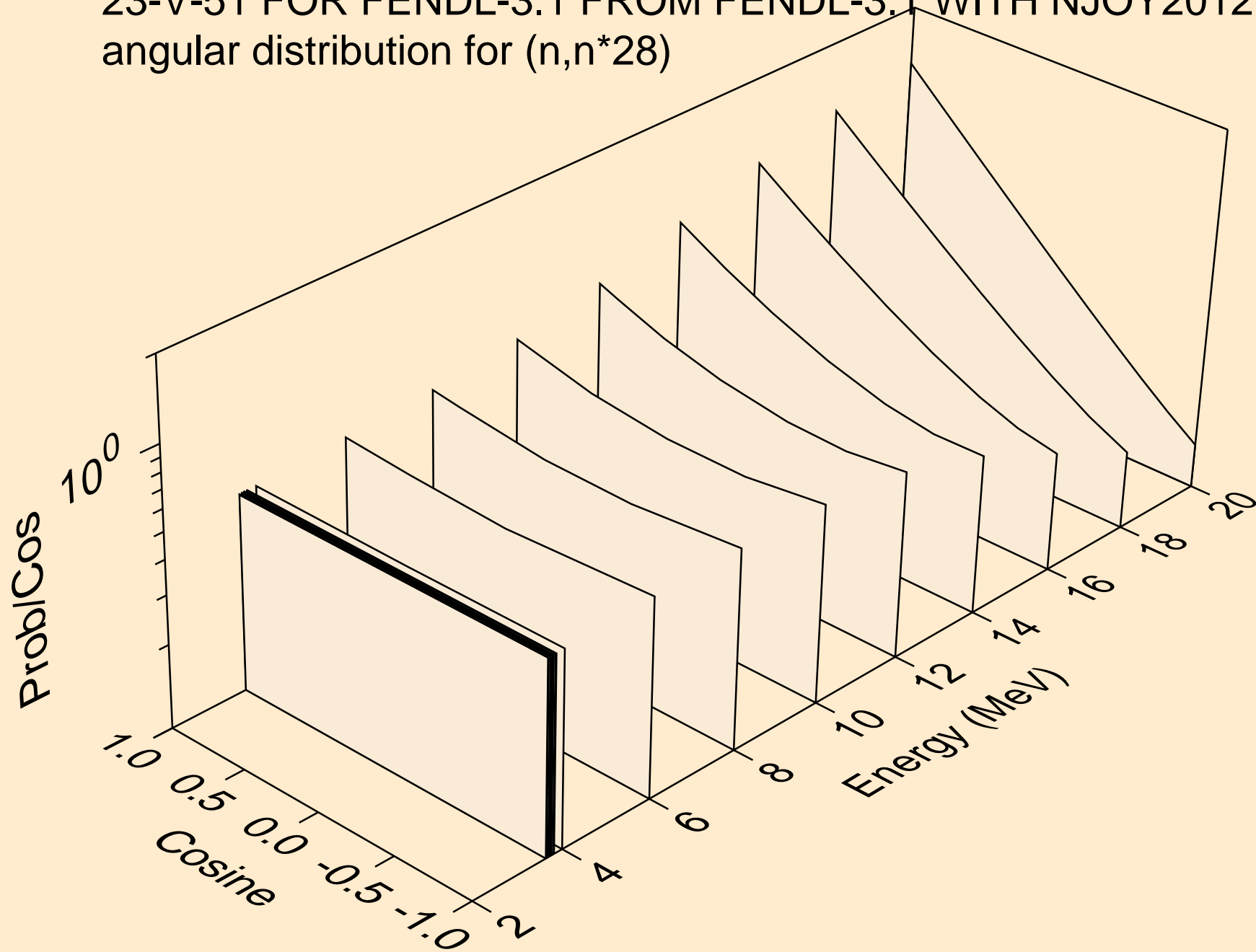

23-V-51 FOR FENDL-3.1 FROM FENDL-3.1 WITH NJOY2012.50+ C
angular distribution for (n,n*29)

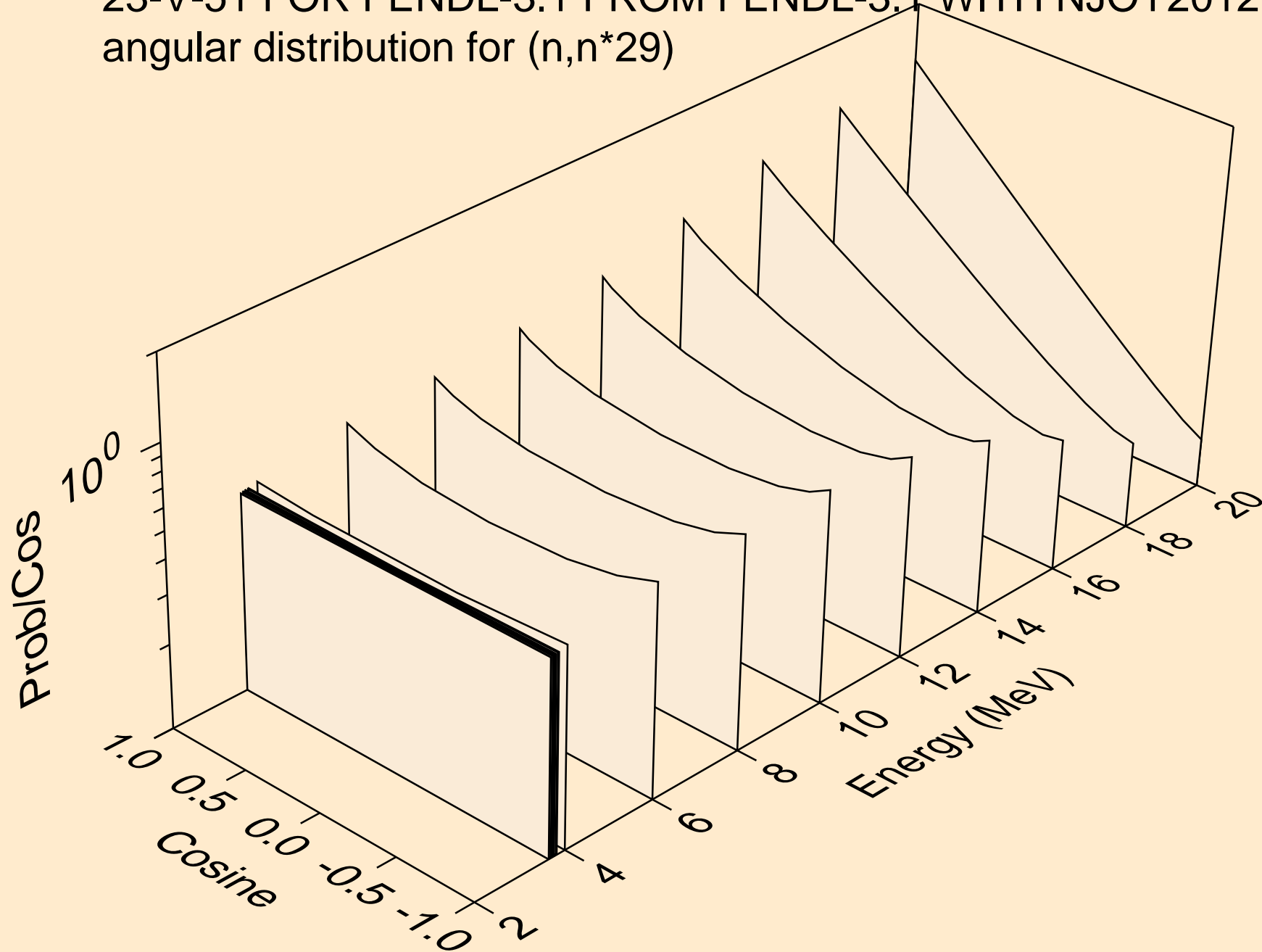

23-V-51 FOR FENDL-3.1 FROM FENDL-3.1 WITH NJOY2012.50+ C
angular distribution for (n,n*30)

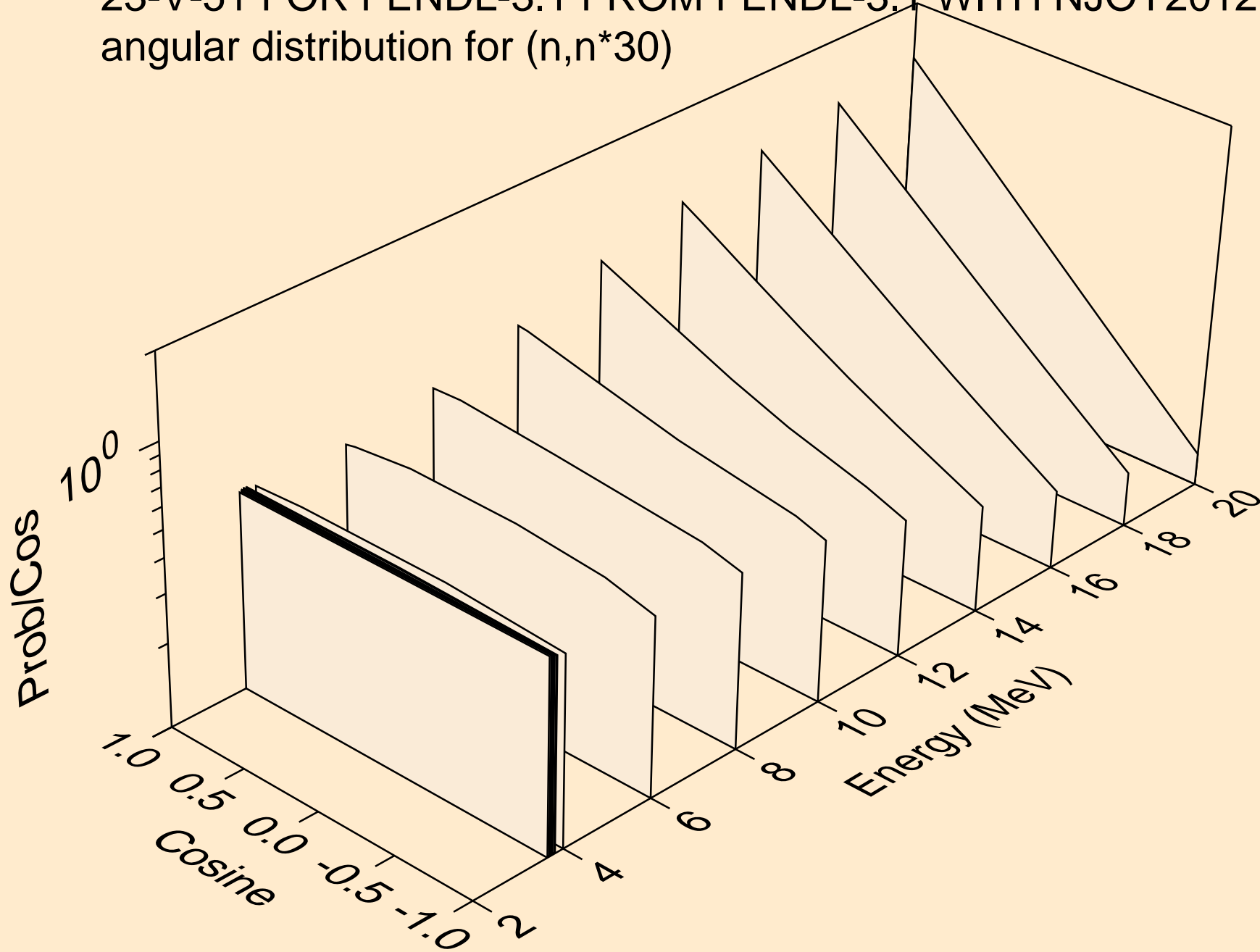

23-V-51 FOR FENDL-3.1 FROM FENDL-3.1 WITH NJOY2012.50+ C
angular distribution for (n,n*31)

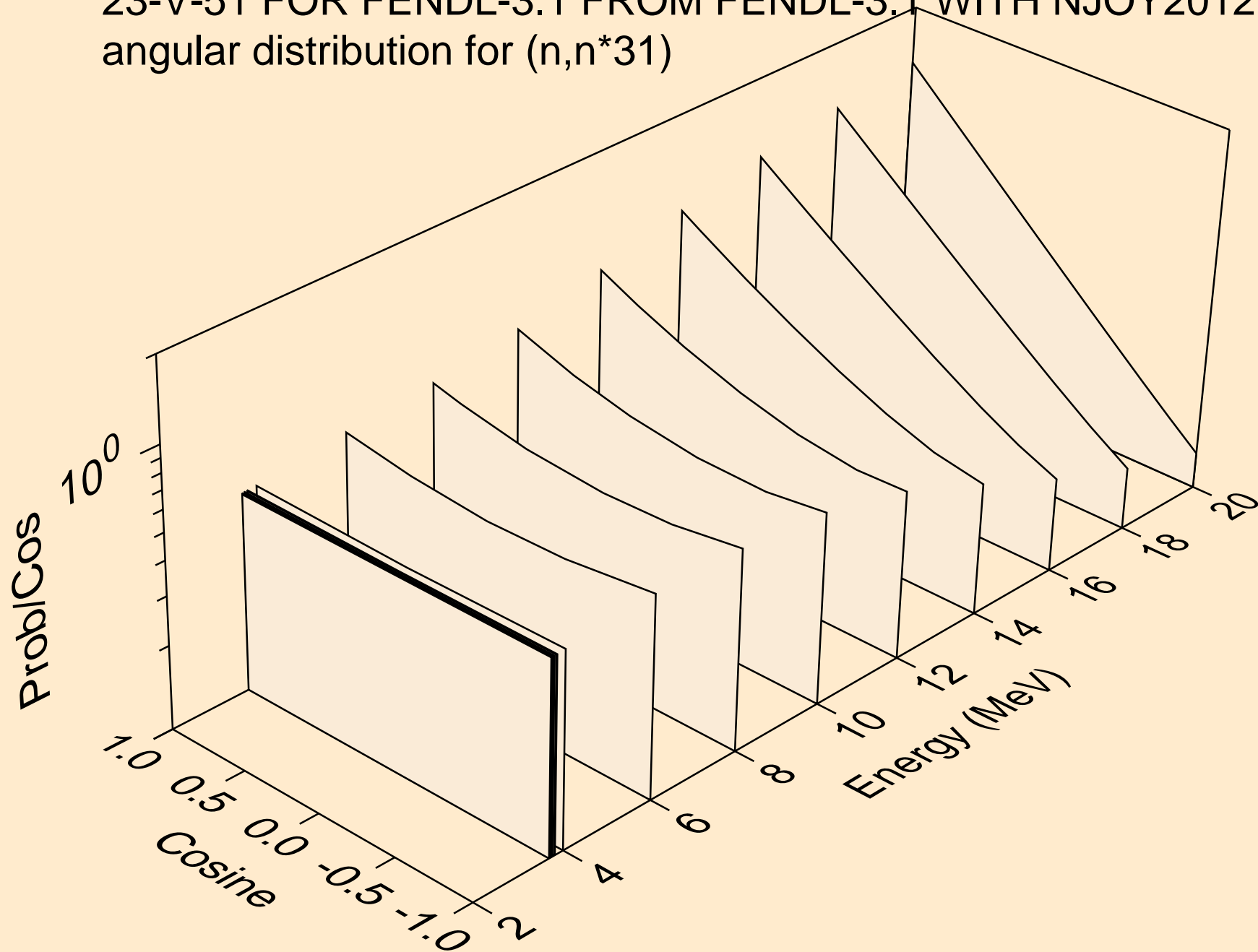

23-V-51 FOR FENDL-3.1 FROM FENDL-3.1 WITH NJOY2012.50+ C
angular distribution for (n,n*32)

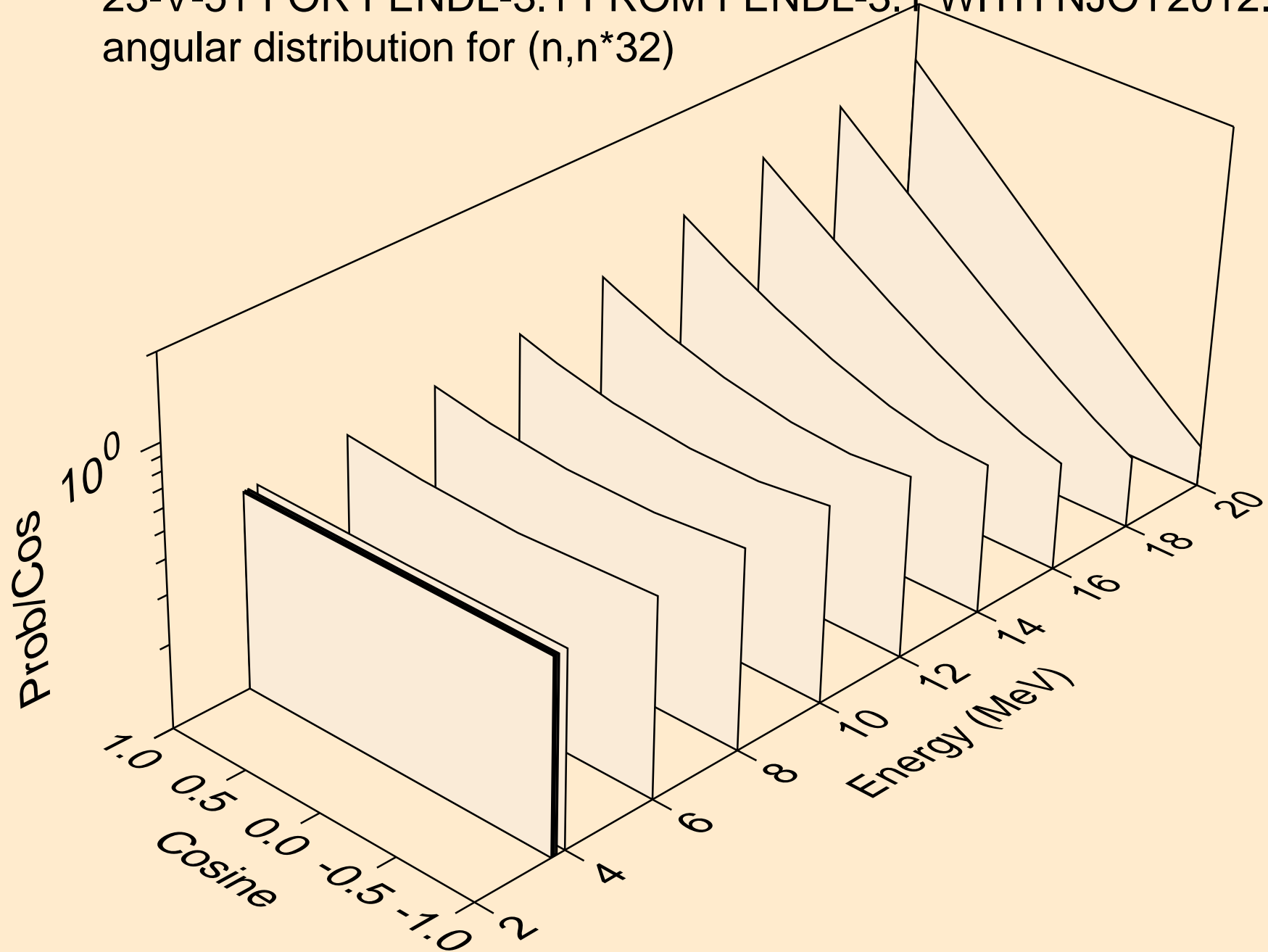

23-V-51 FOR FENDL-3.1 FROM FENDL-3.1 WITH NJOY2012.50+ C
angular distribution for (n,n*33)

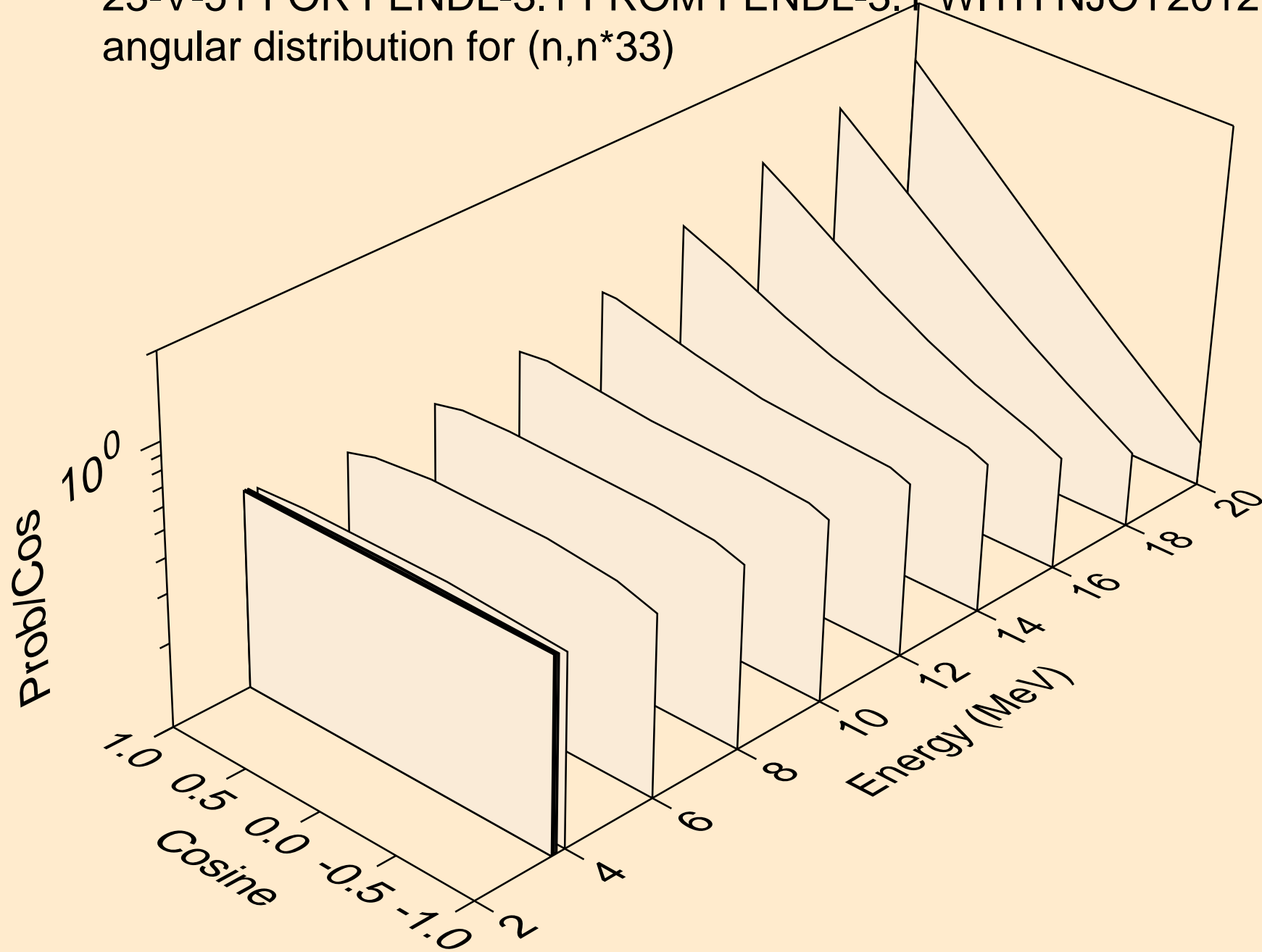

23-V-51 FOR FENDL-3.1 FROM FENDL-3.1 WITH NJOY2012.50+ C
angular distribution for (n,n*34)

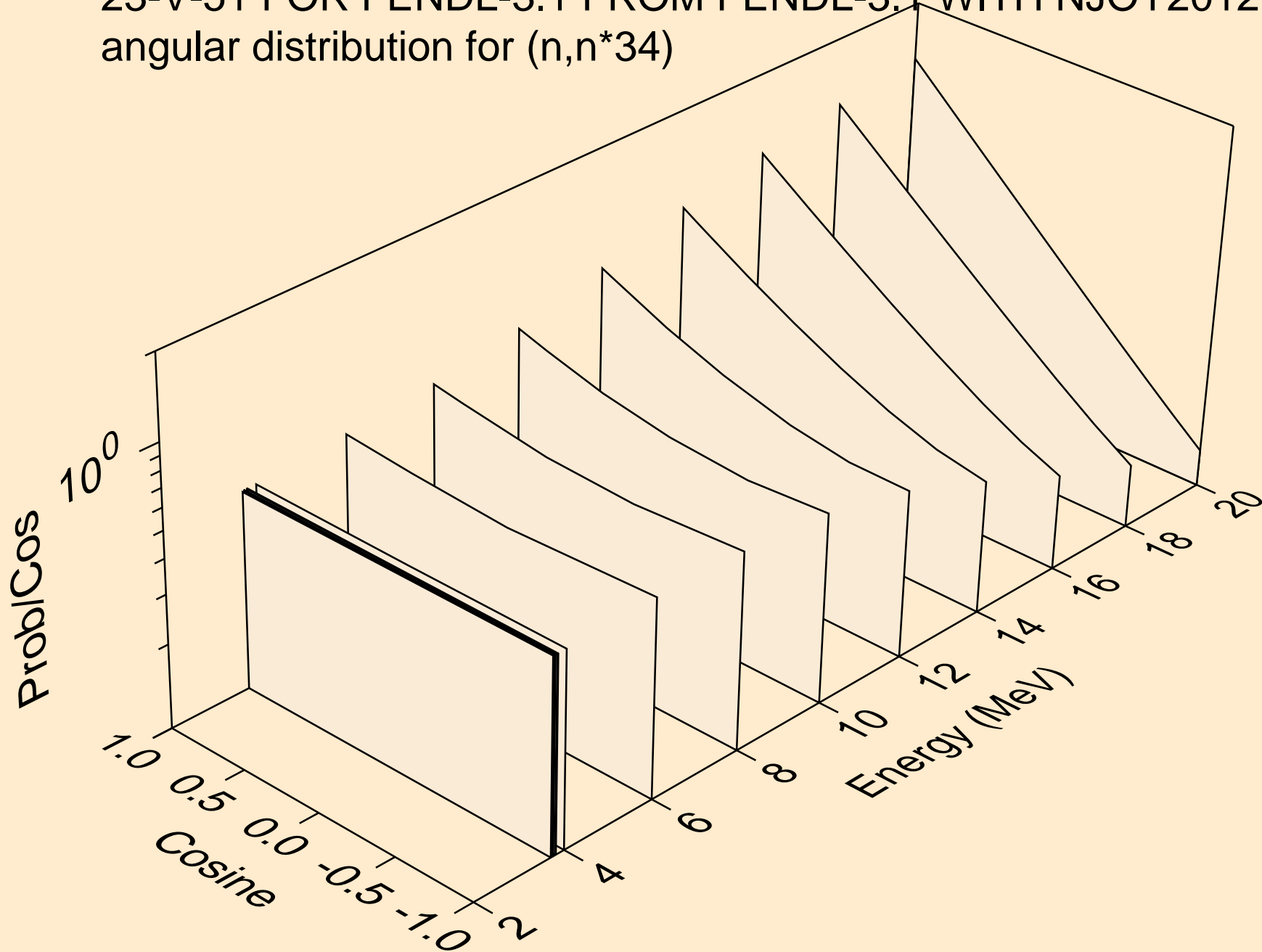

23-V-51 FOR FENDL-3.1 FROM FENDL-3.1 WITH NJOY2012.50+ C
angular distribution for (n,n*35)

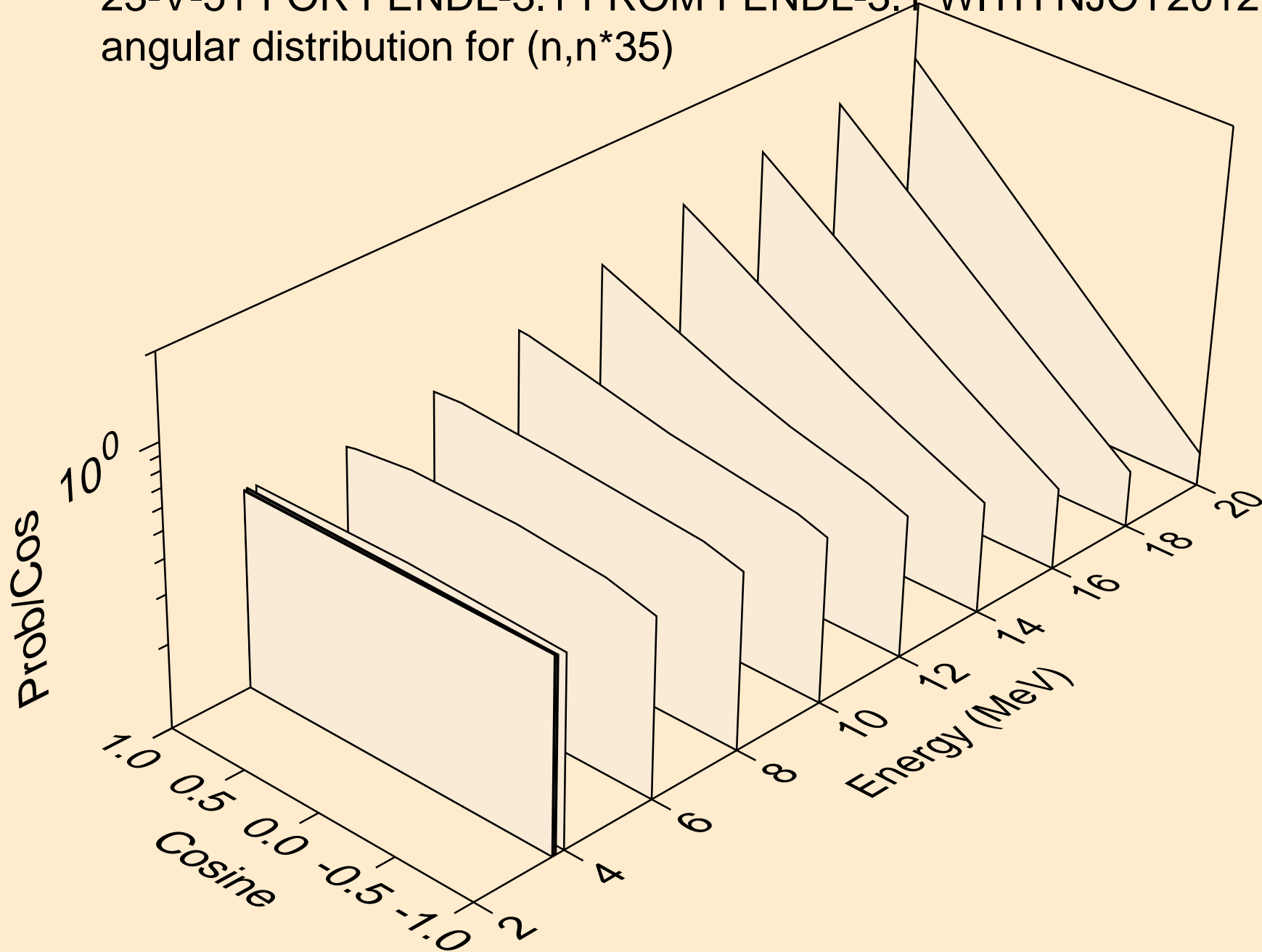

23-V-51 FOR FENDL-3.1 FROM FENDL-3.1 WITH NJOY2012.50+ C
angular distribution for (n,n*36)

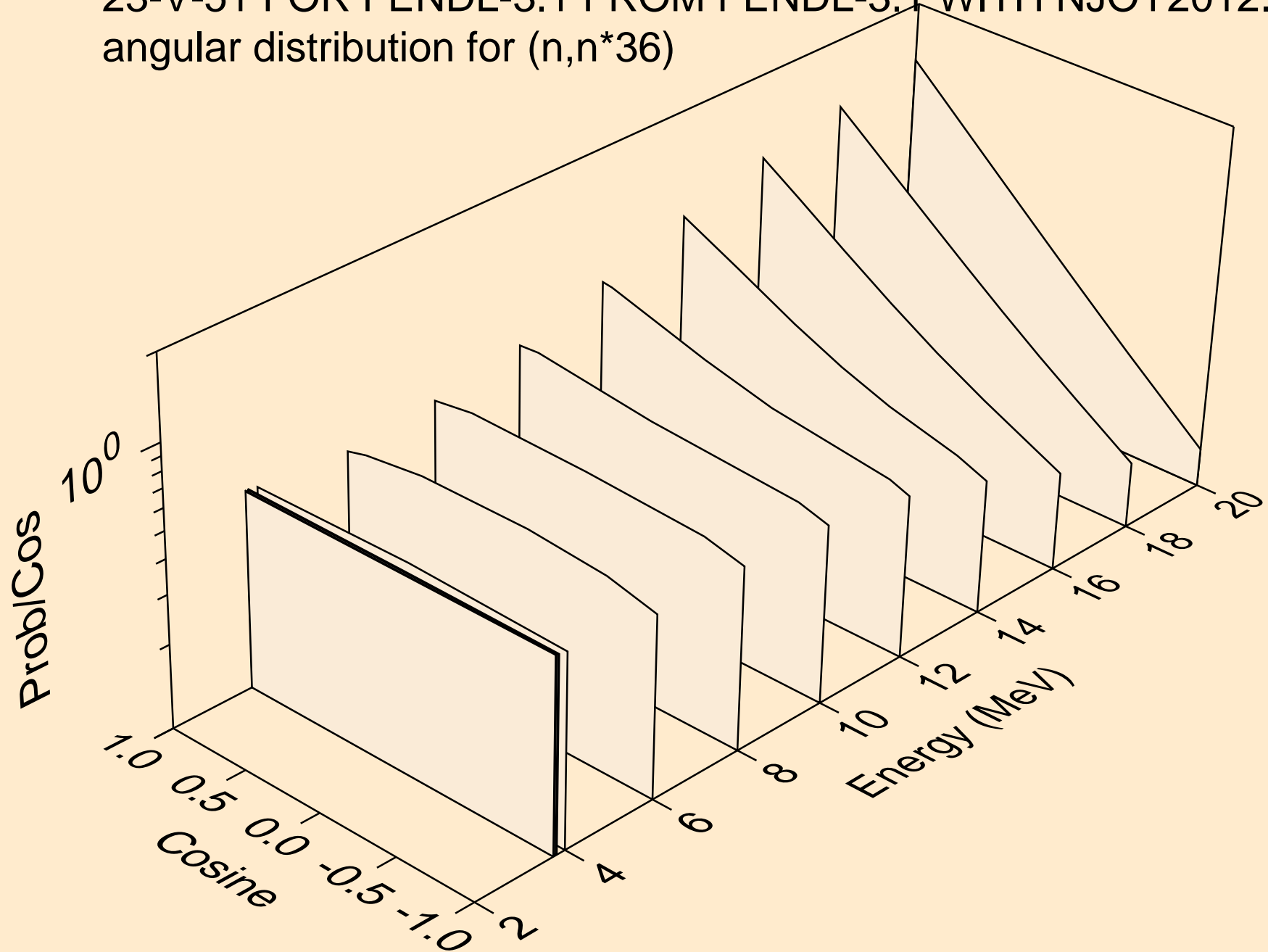

23-V-51 FOR FENDL-3.1 FROM FENDL-3.1 WITH NJOY2012.50+ C
angular distribution for (n,n*37)

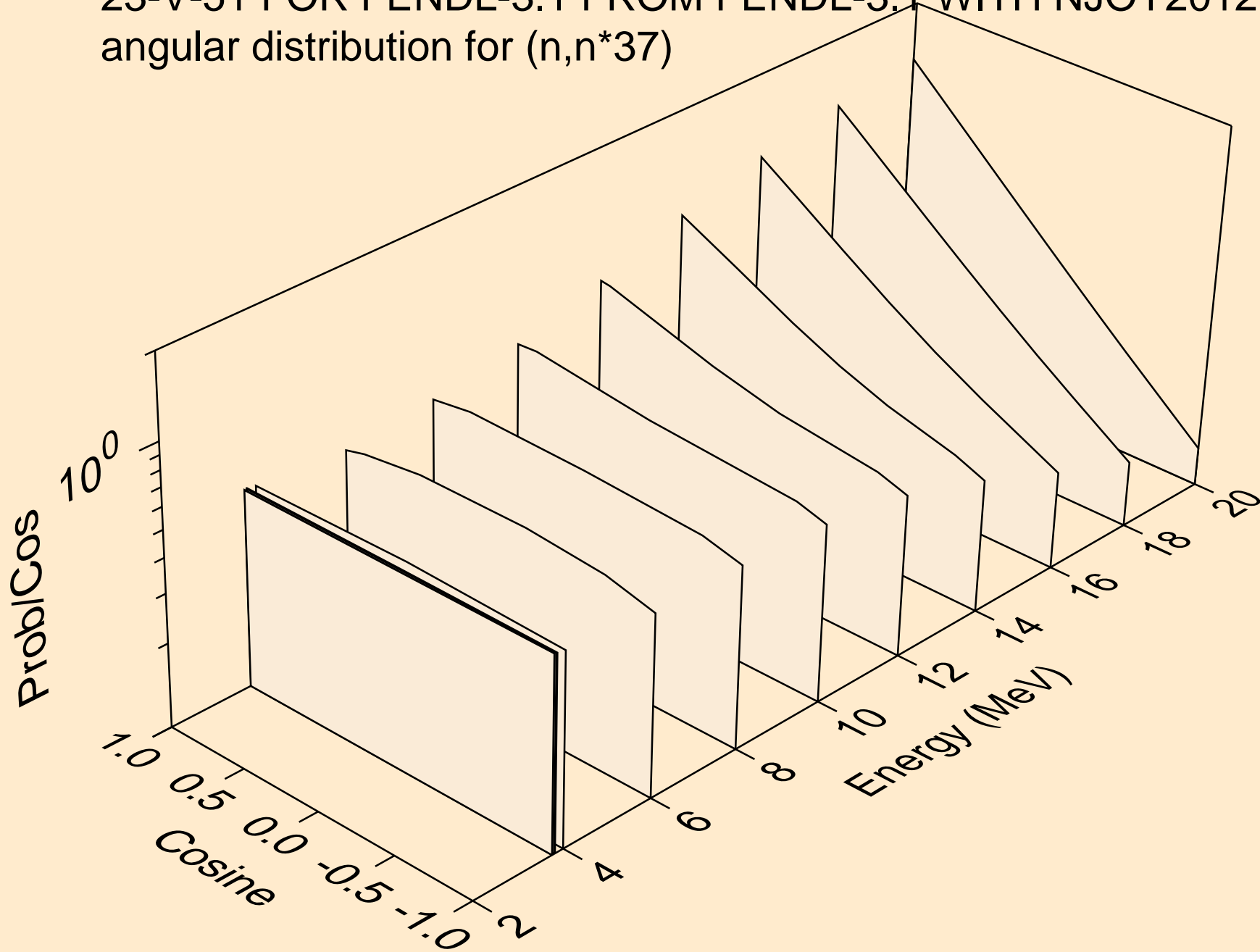

23-V-51 FOR FENDL-3.1 FROM FENDL-3.1 WITH NJOY2012.50+ C
angular distribution for (n,n*38)

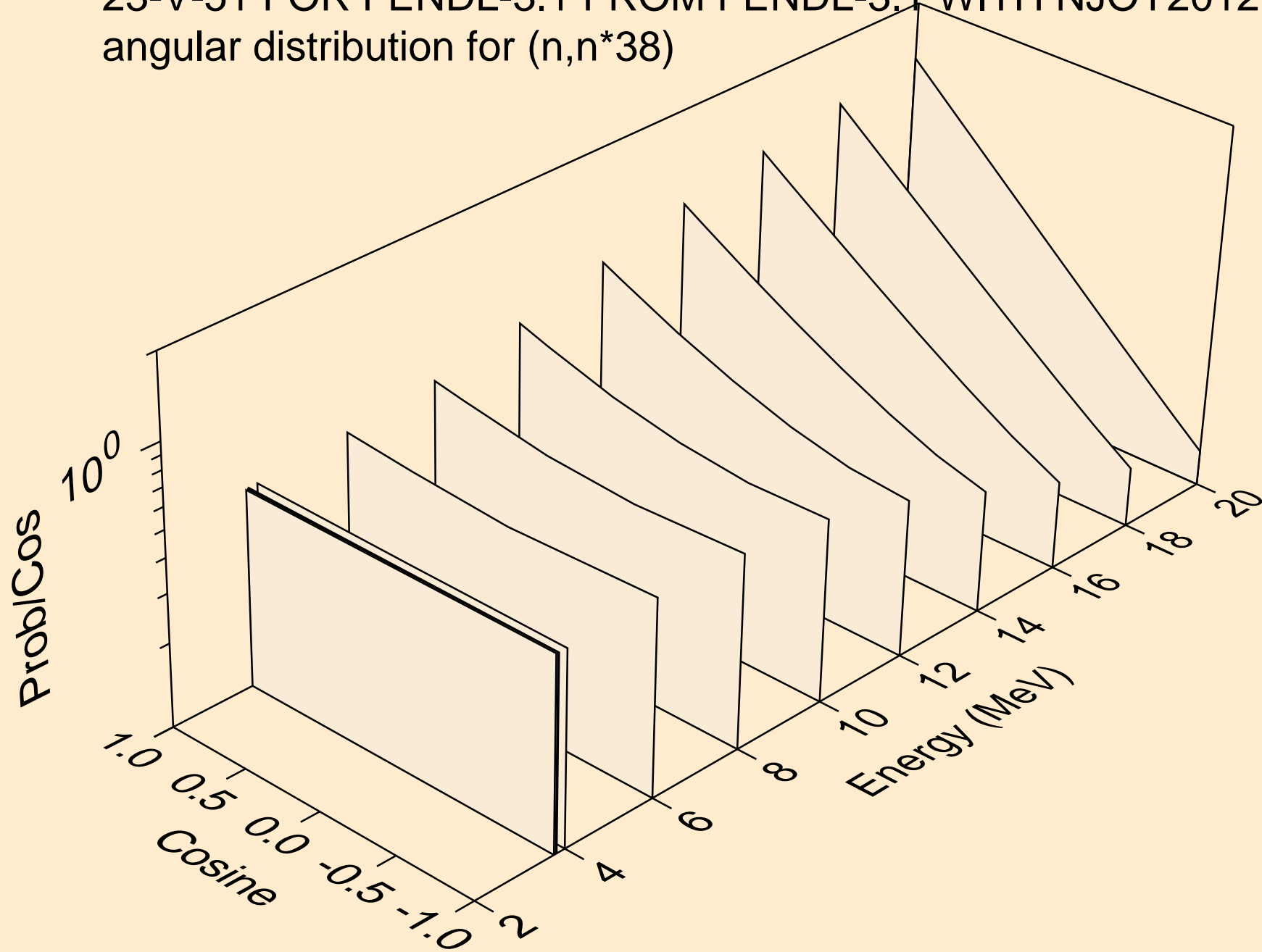

23-V-51 FOR FENDL-3.1 FROM FENDL-3.1 WITH NJOY2012.50+ C
angular distribution for (n,n*39)

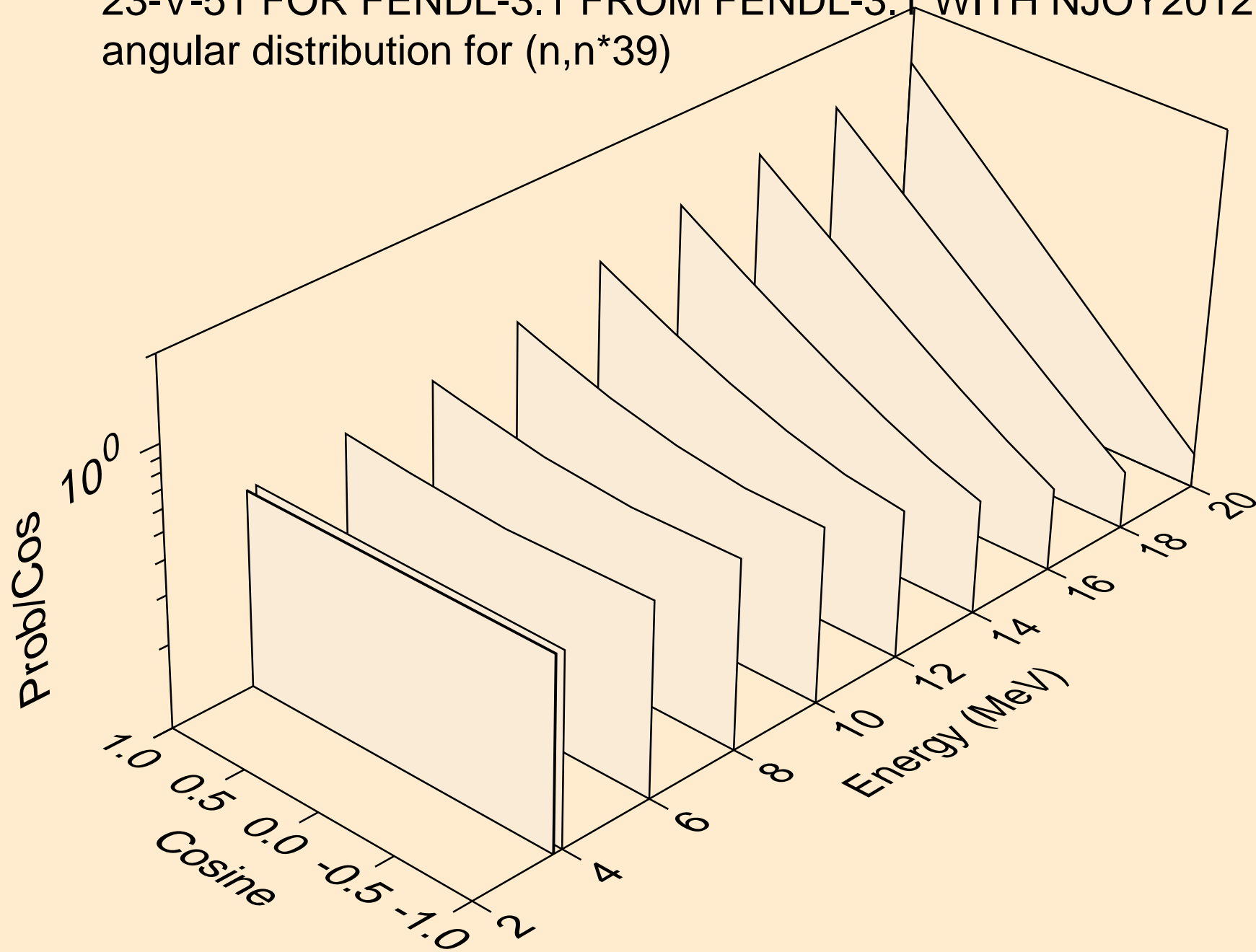

23-V-51 FOR FENDL-3.1 FROM FENDL-3.1 WITH NJOY2012.50+ C
angular distribution for (n,n*40)

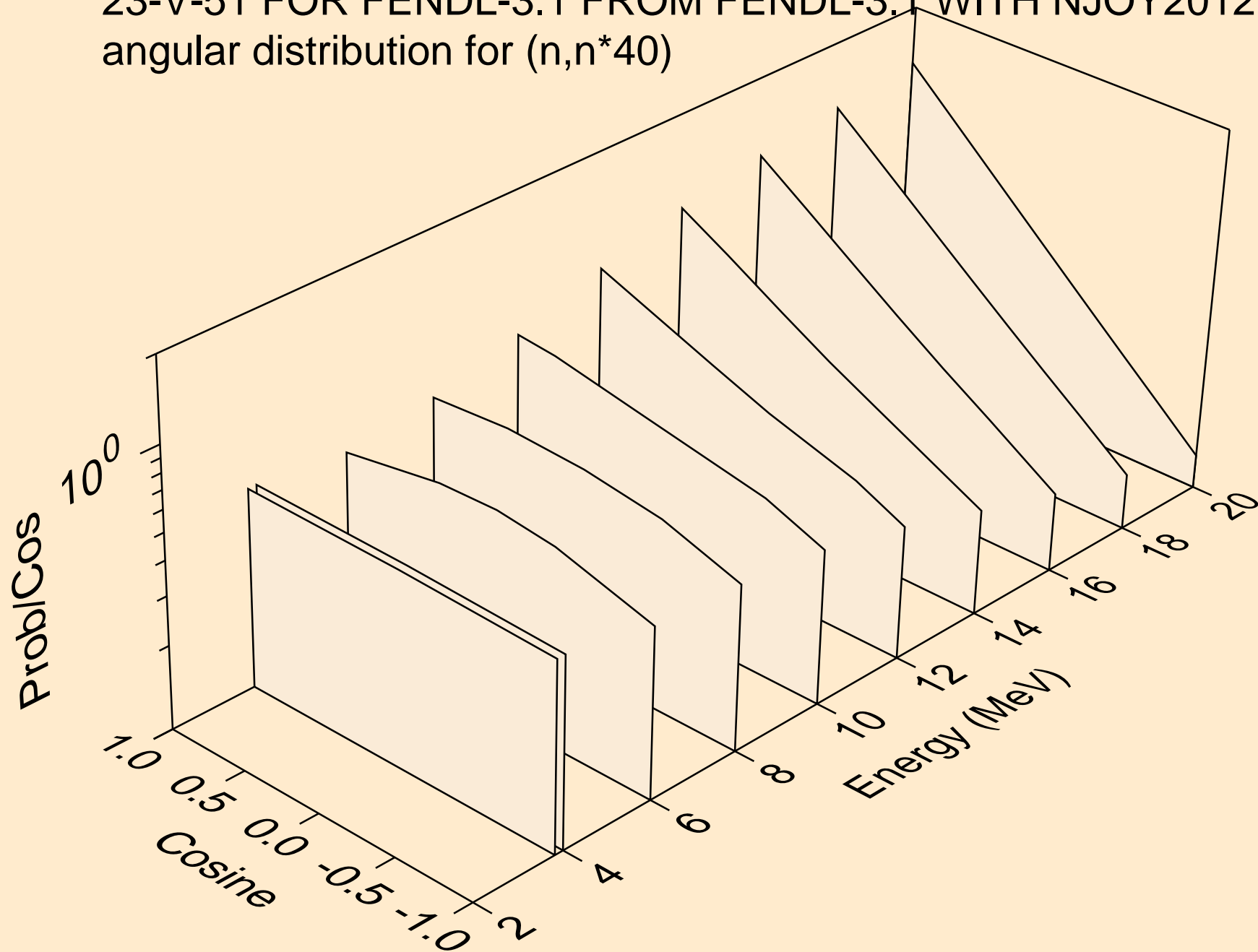

23-V-51 FOR FENDL-3.1 FROM FENDL-3.1 WITH NJOY2012.50+ C
Neutron emission for (n,x)

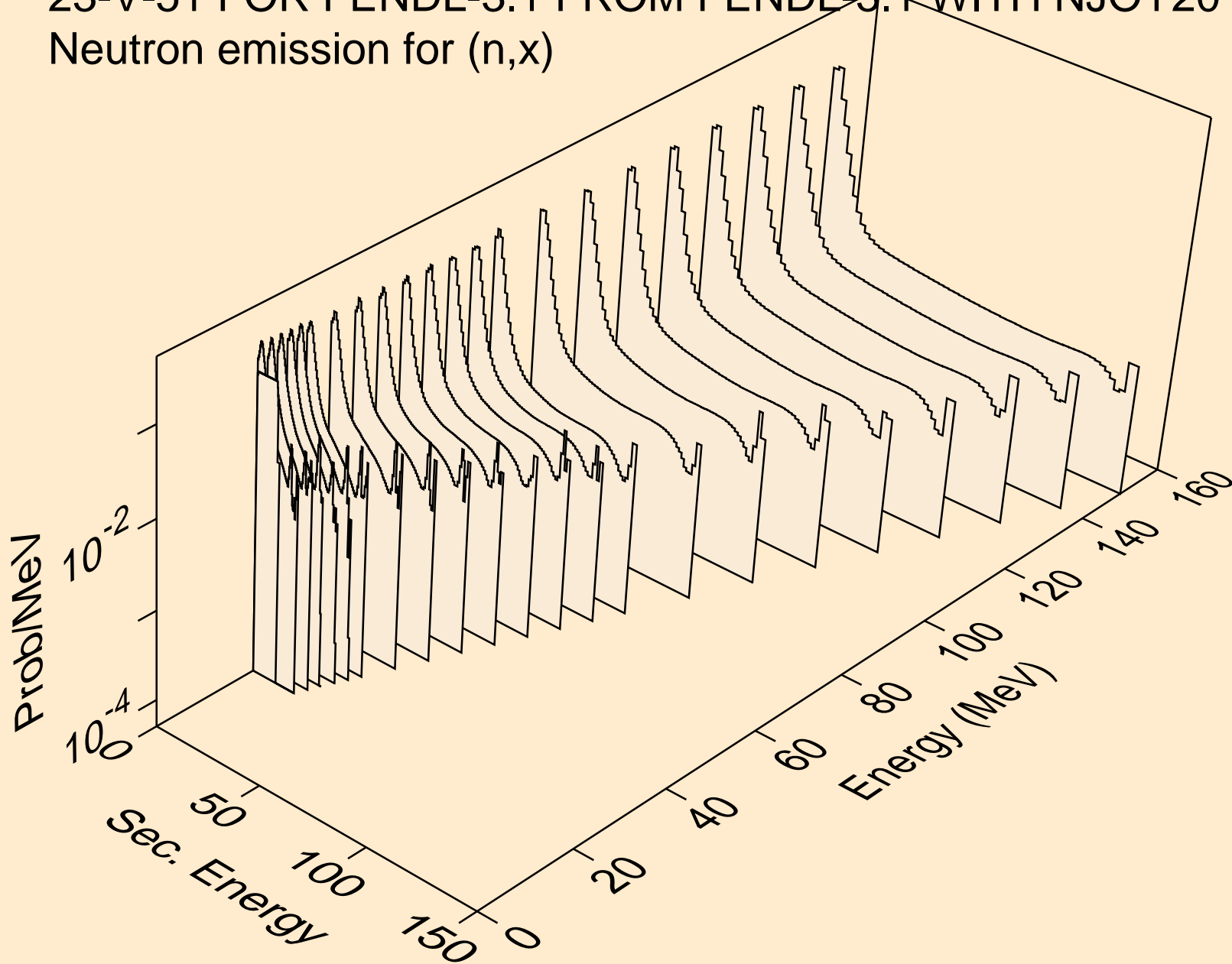

23-V-51 FOR FENDL-3.1 FROM FENDL-3.1 WITH NJOY2012.50+ C
Neutron emission for (n,2n)

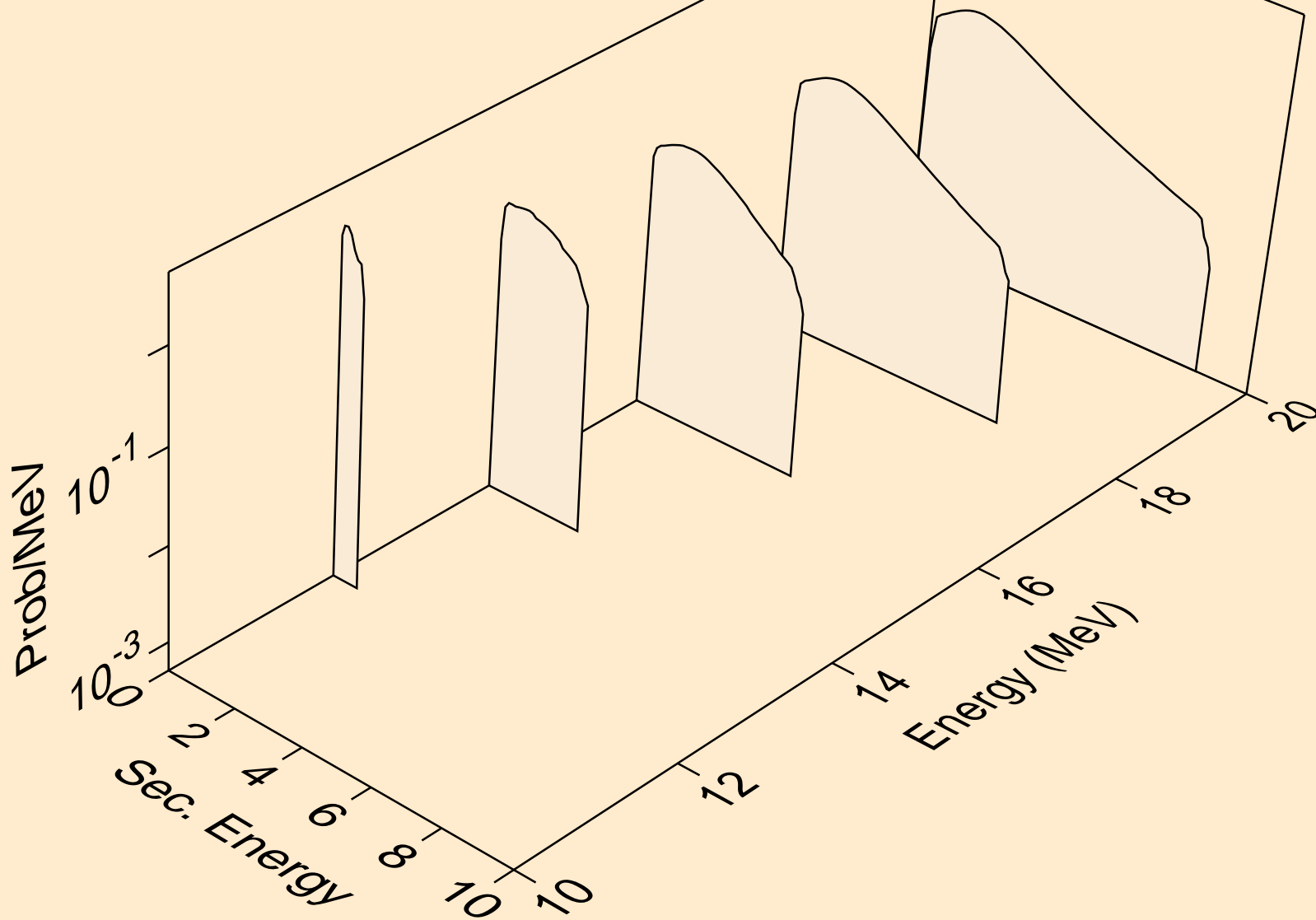

23-V-51 FOR FENDL-3.1 FROM FENDL-3.1 WITH NJOY2012.50+ C
Neutron emission for (n,n*)a

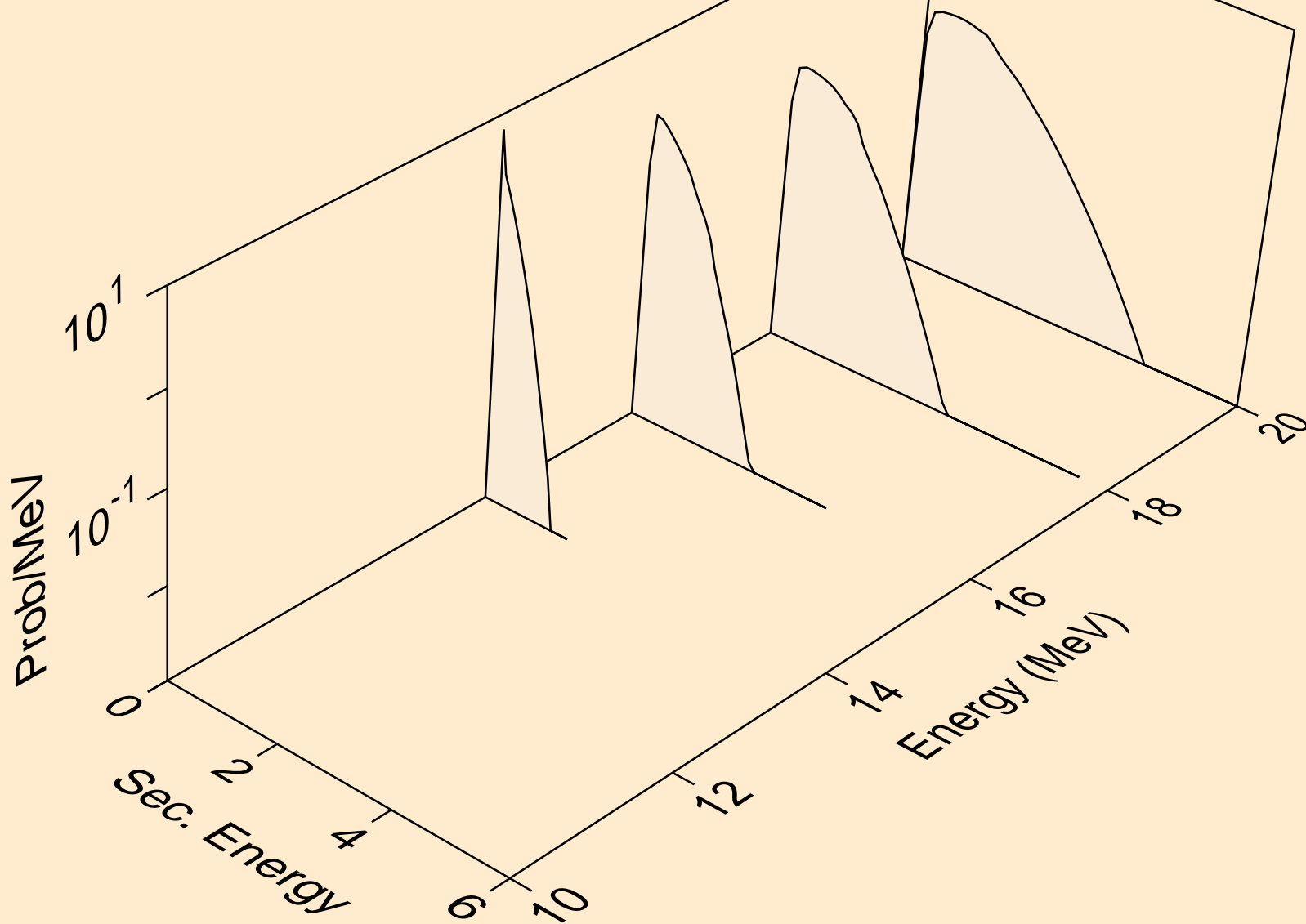

23-V-51 FOR FENDL-3.1 FROM FENDL-3.1 WITH NJOY2012.50+ C
Neutron emission for (n,n*)p

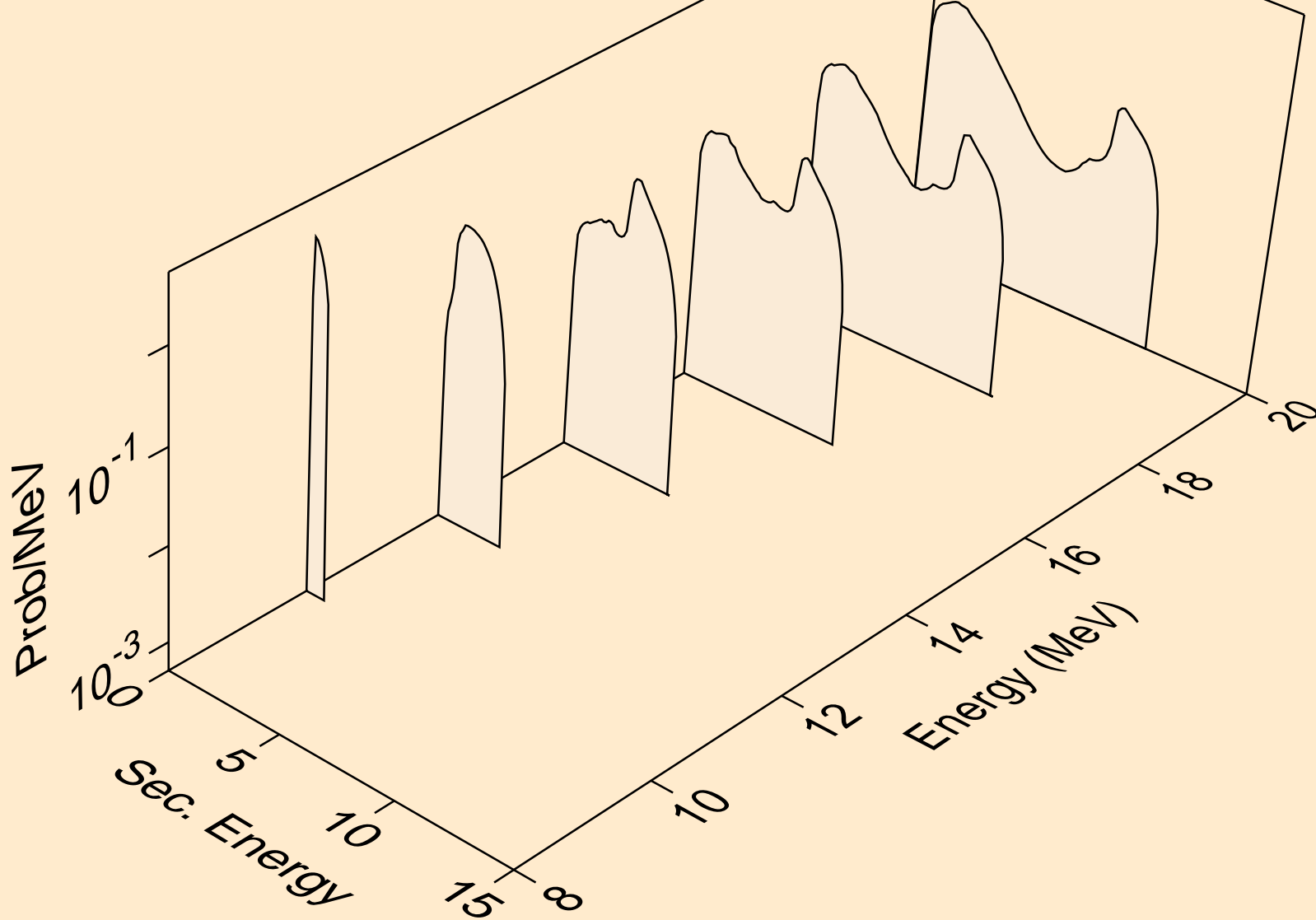

23-V-51 FOR FENDL-3.1 FROM FENDL-3.1 WITH NJOY2012.50+ C
Neutron emission for (n,n*)d

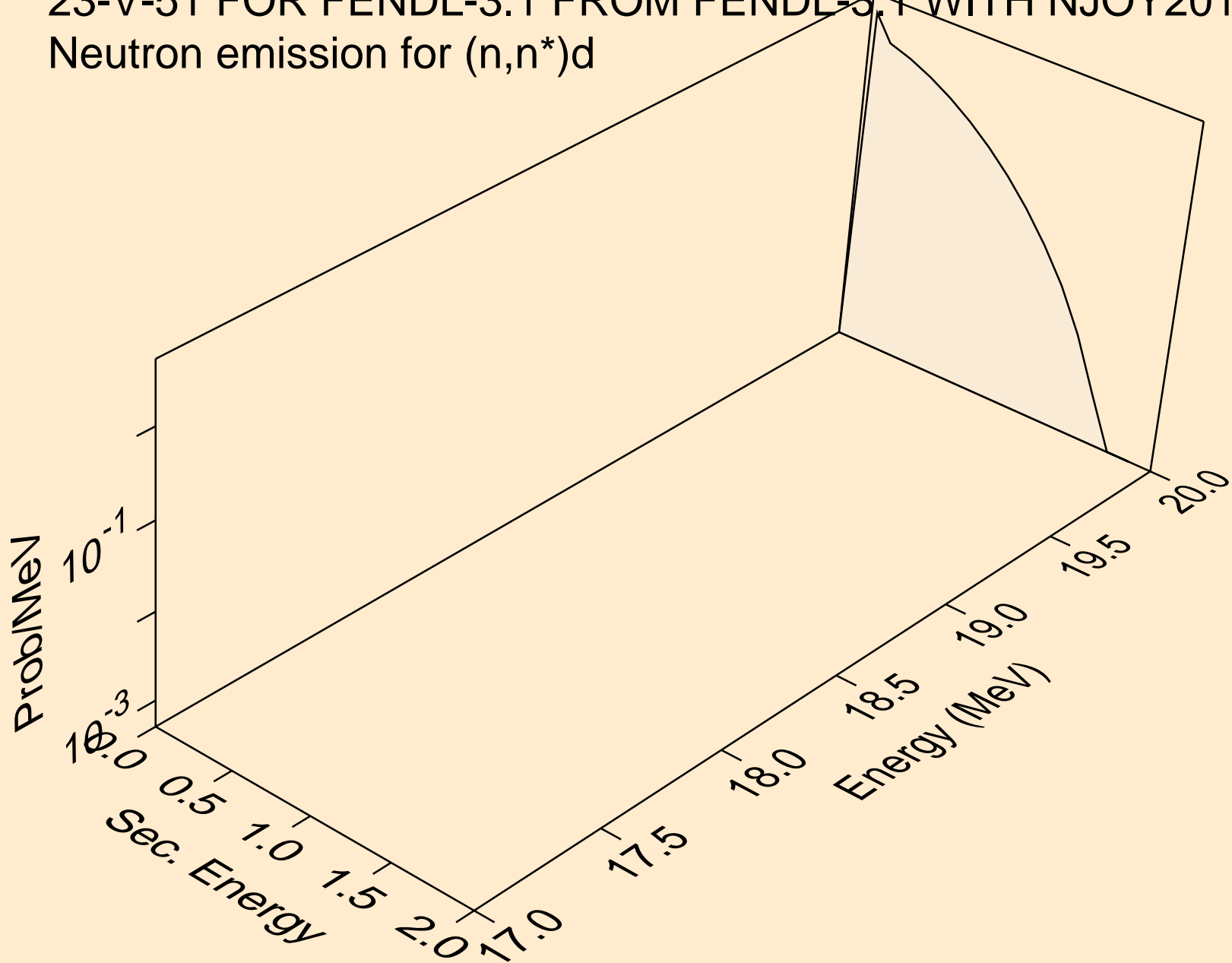

23-V-51 FOR FENDL-3.1 FROM FENDL-3.1 WITH NJOY2012.50+ C
Neutron emission for (n,n*c)

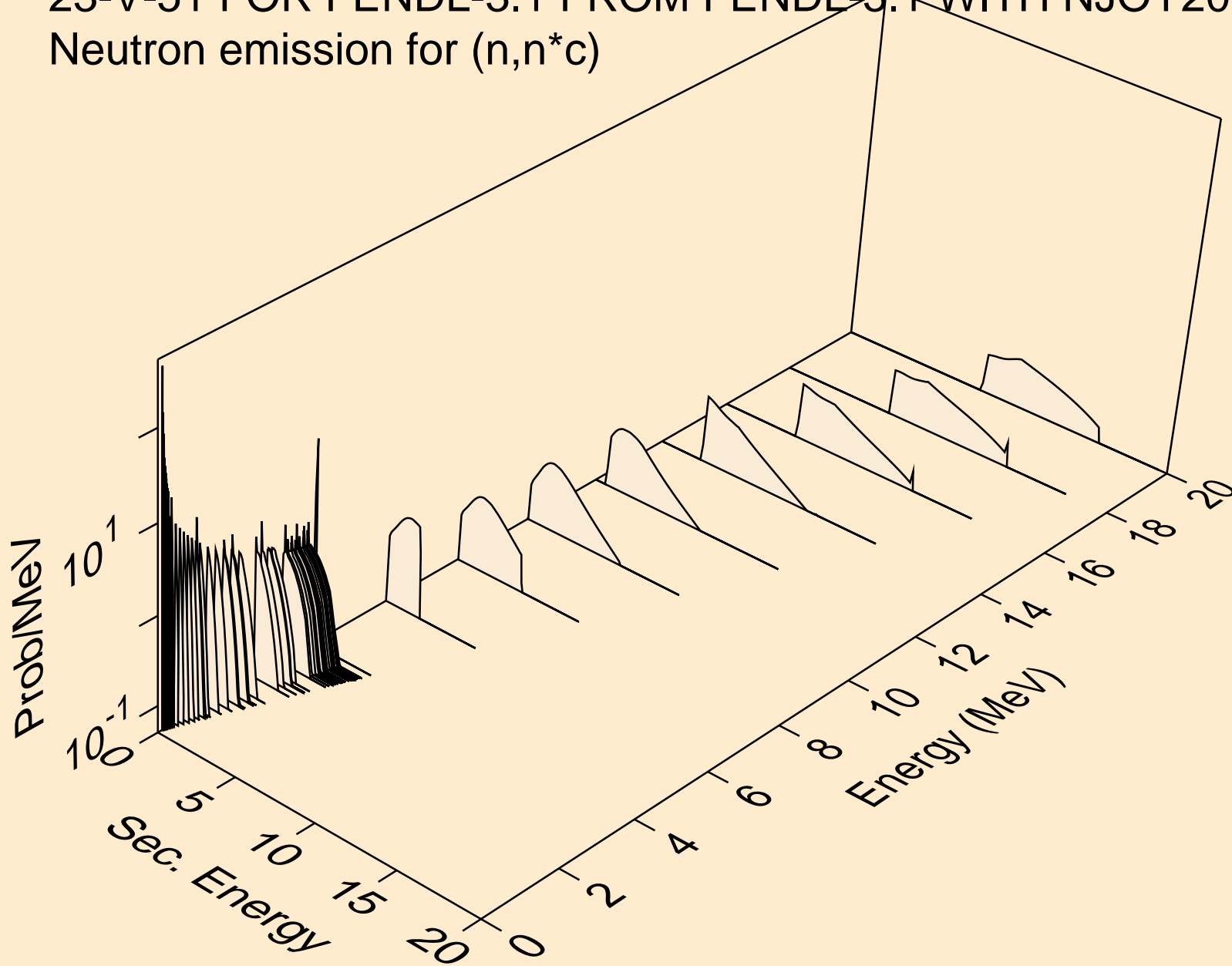

23-V-51 FOR FENDL-3.1 FROM FENDL-3.1 WITH NJOY2012.50+ C
Photon emission for (n,x)

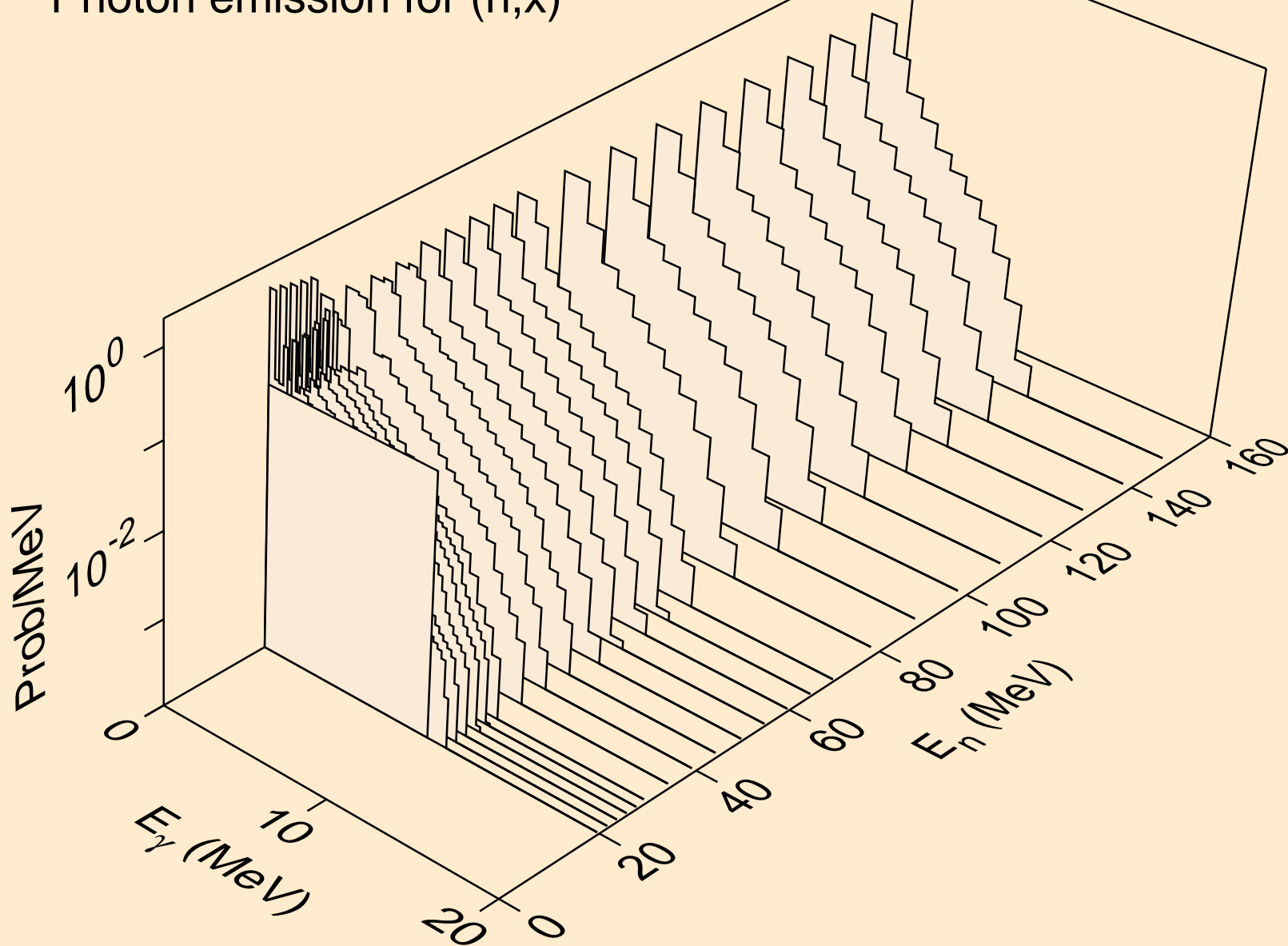

23-V-51 FOR FENDL-3.1 FROM FENDL-3.1 WITH NJOY2012.50+ C
Photon emission for (n,2n)

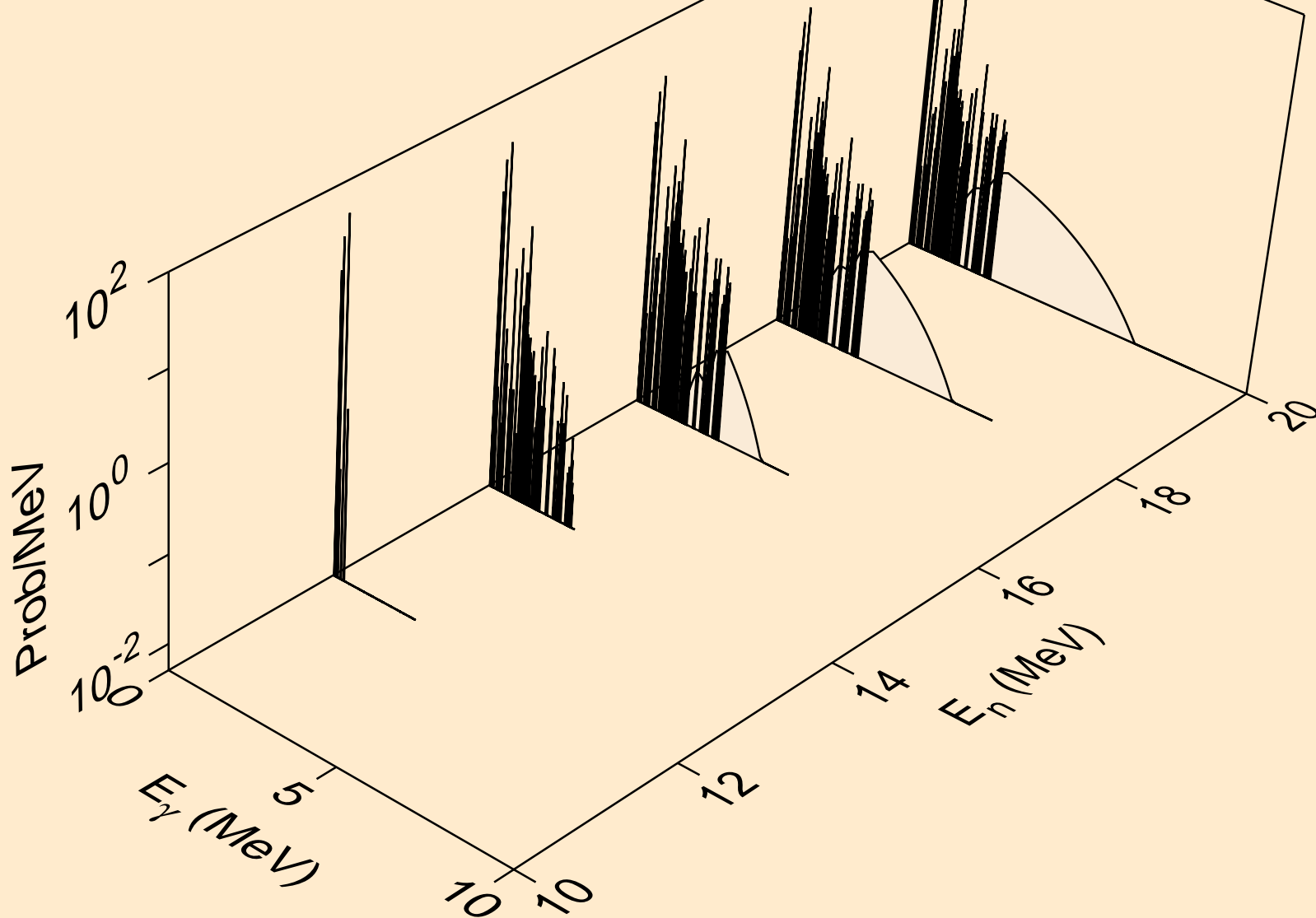

23-V-51 FOR FENDL-3.1 FROM FENDL-3.1 WITH NJOY2012.50+ C
Photon emission for (n,n*)a

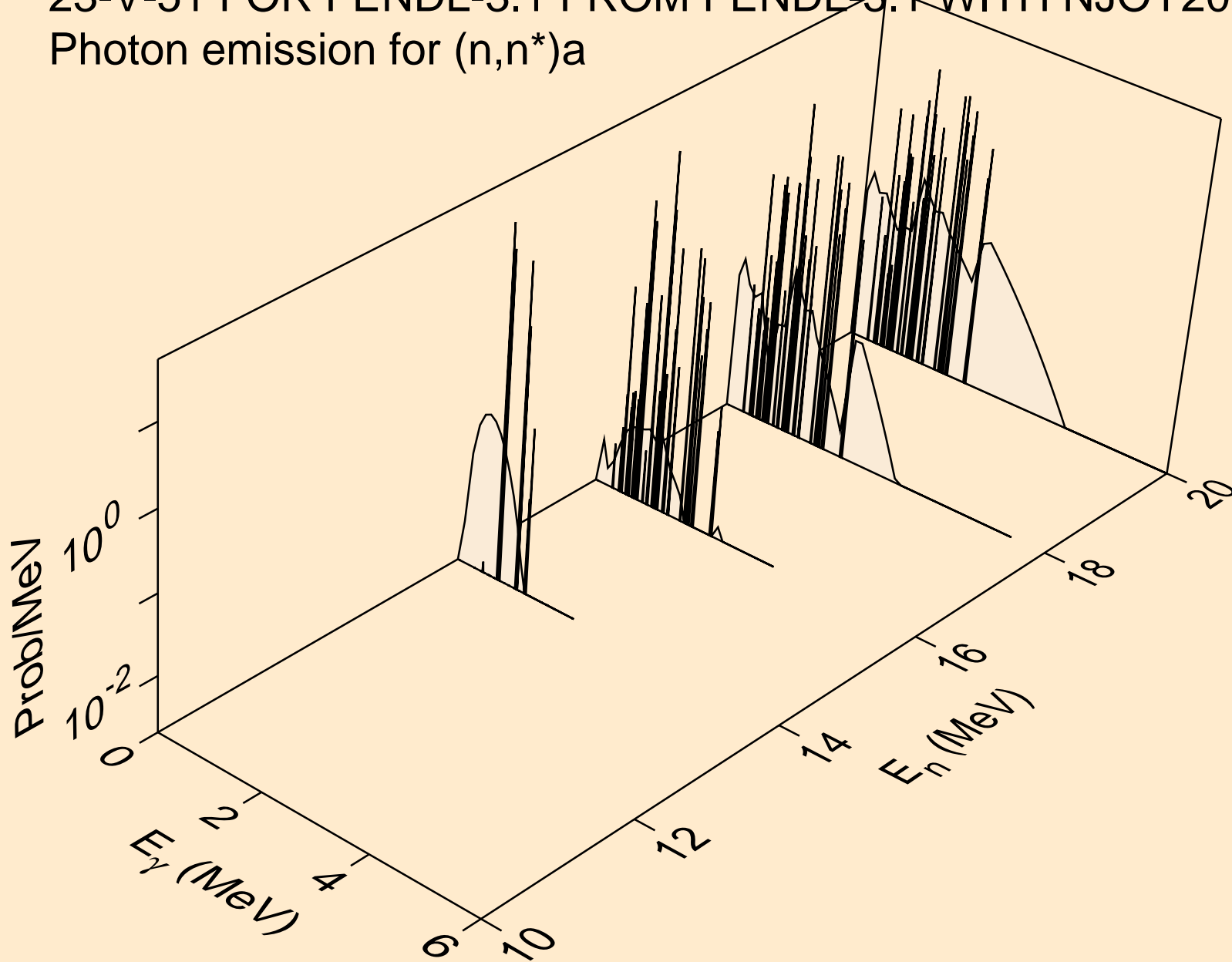

23-V-51 FOR FENDL-3.1 FROM FENDL-3.1 WITH NJOY2012.50+ C
Photon emission for (n,n*)p

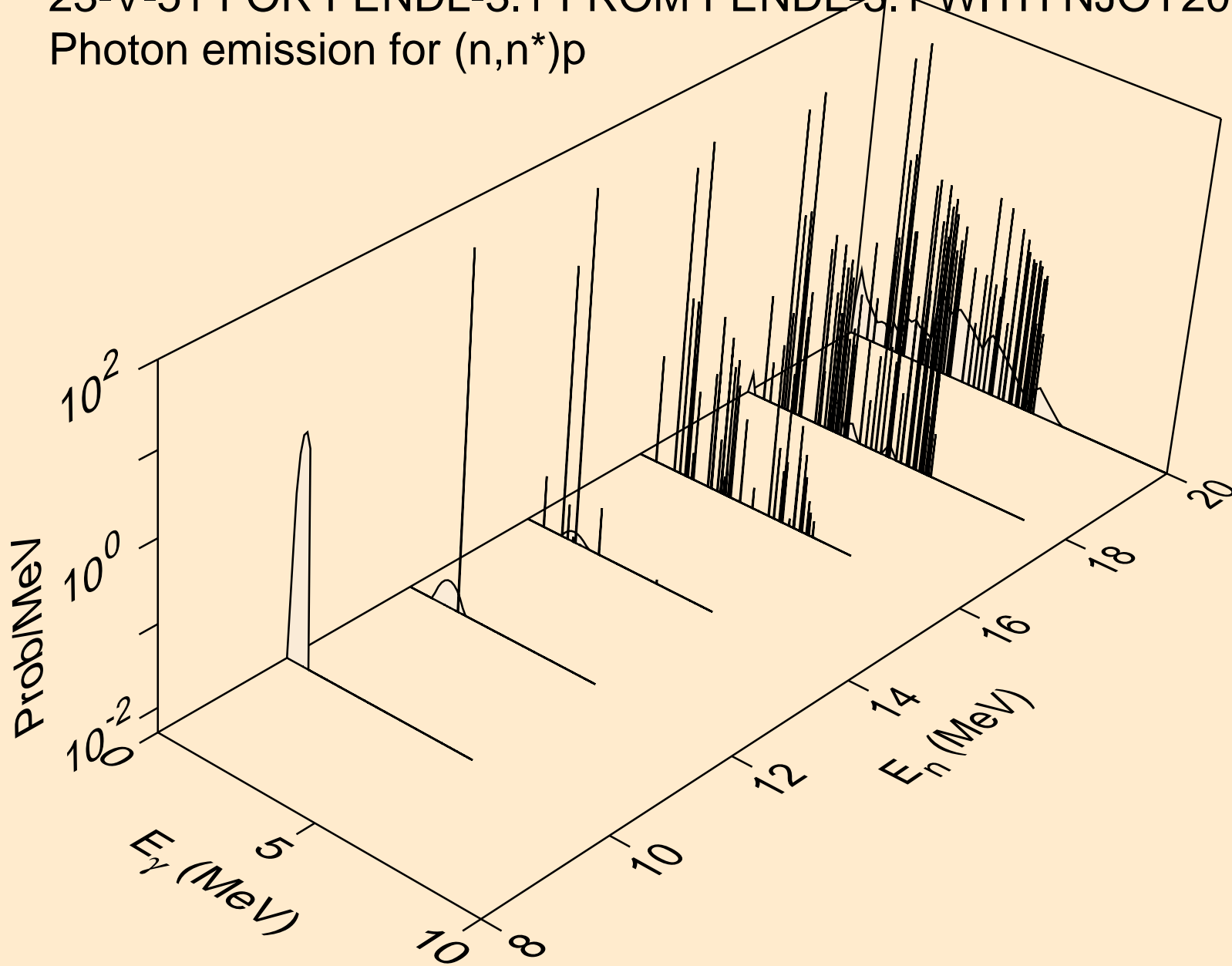

23-V-51 FOR FENDL-3.1 FROM FENDL-3.1 WITH NJOY2012.50+ C
Photon emission for (n,n*)d

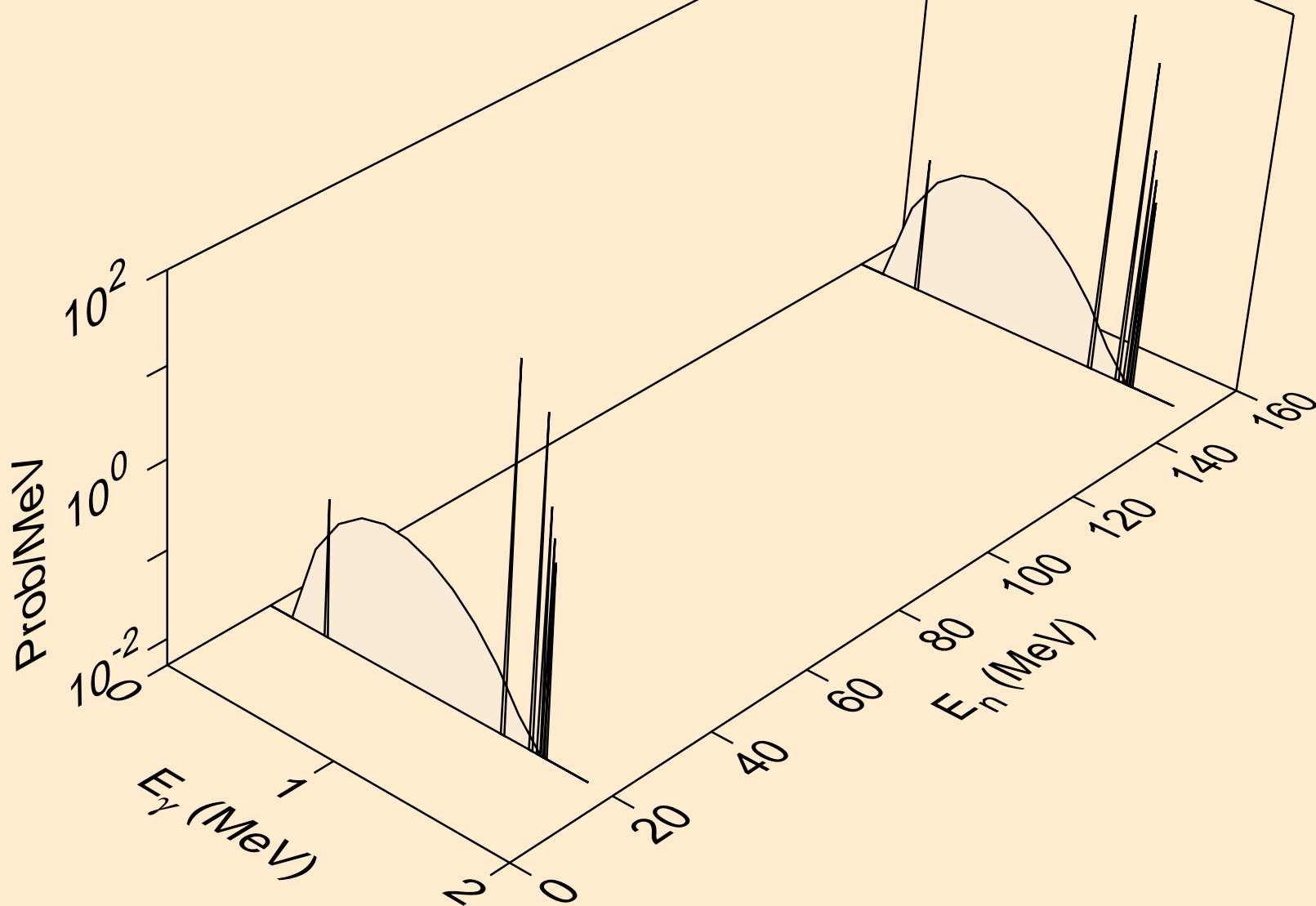

23-V-51 FOR FENDL-3.1 FROM FENDL-3.1 WITH NJOY2012.50+ C
Photon emission for (n,n*1)

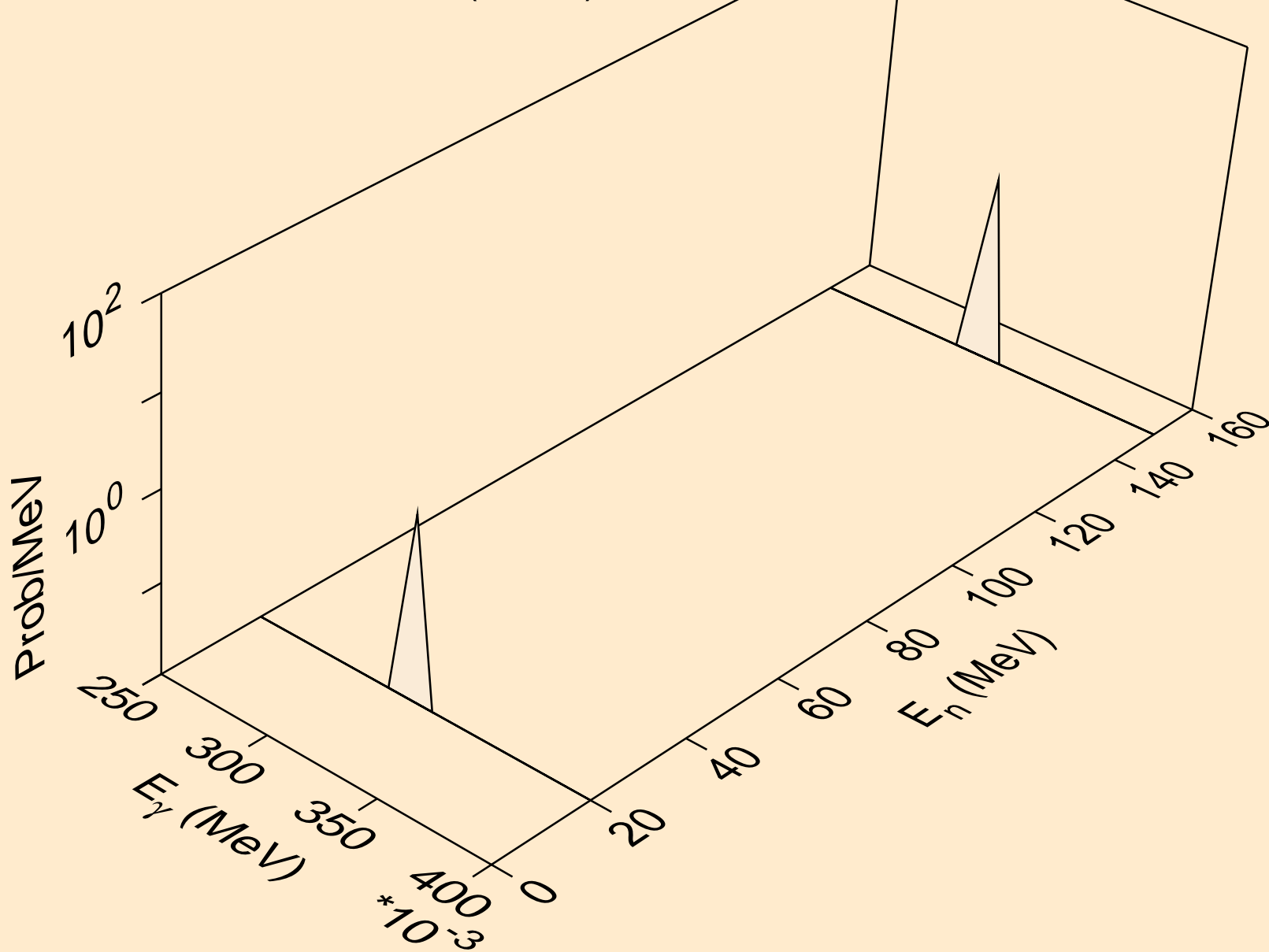

23-V-51 FOR FENDL-3.1 FROM FENDL-3.1 WITH NJOY2012.50+ C
Photon emission for (n,n*2)

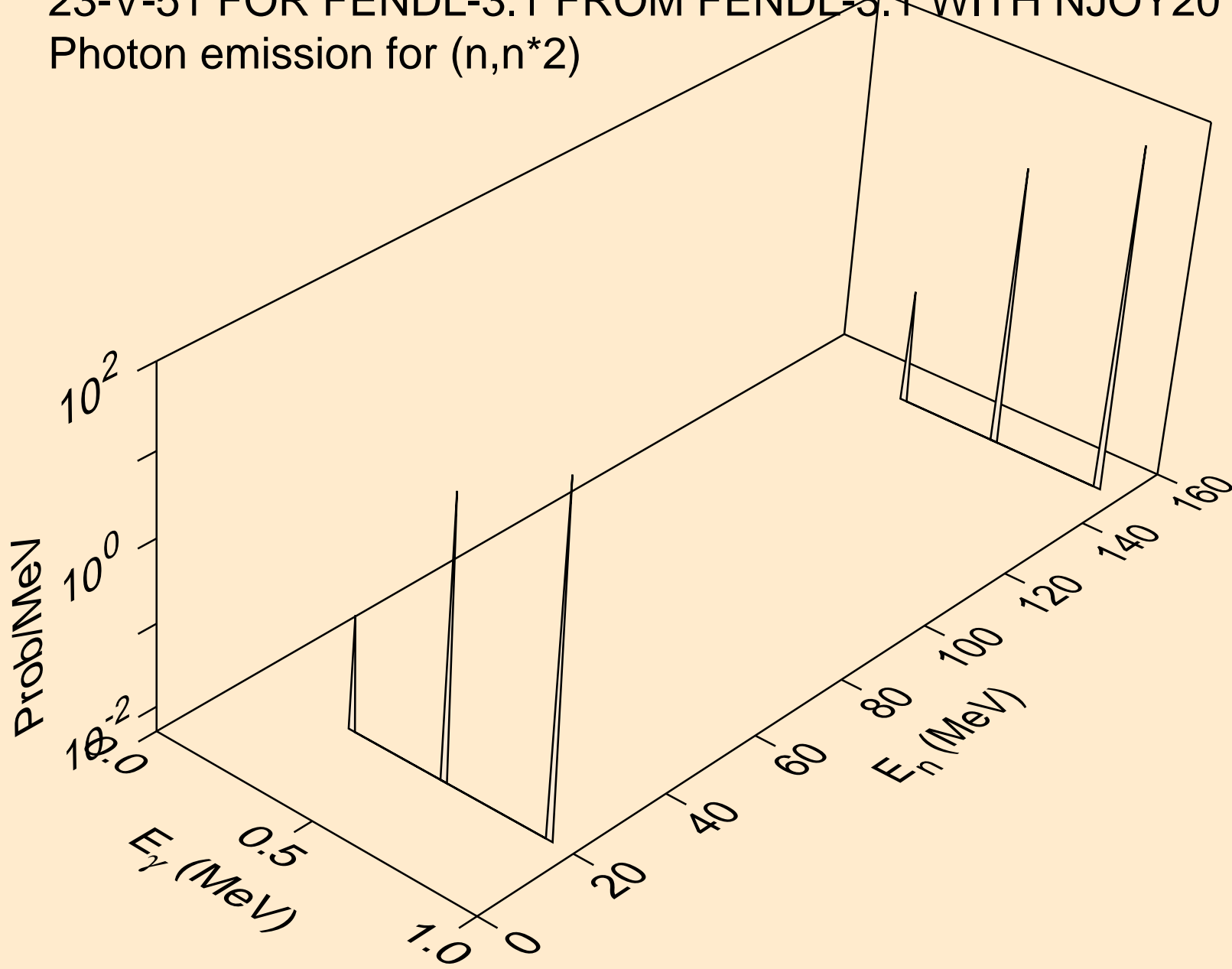

23-V-51 FOR FENDL-3.1 FROM FENDL-3.1 WITH NJOY2012.50+ C
Photon emission for (n,n*3)

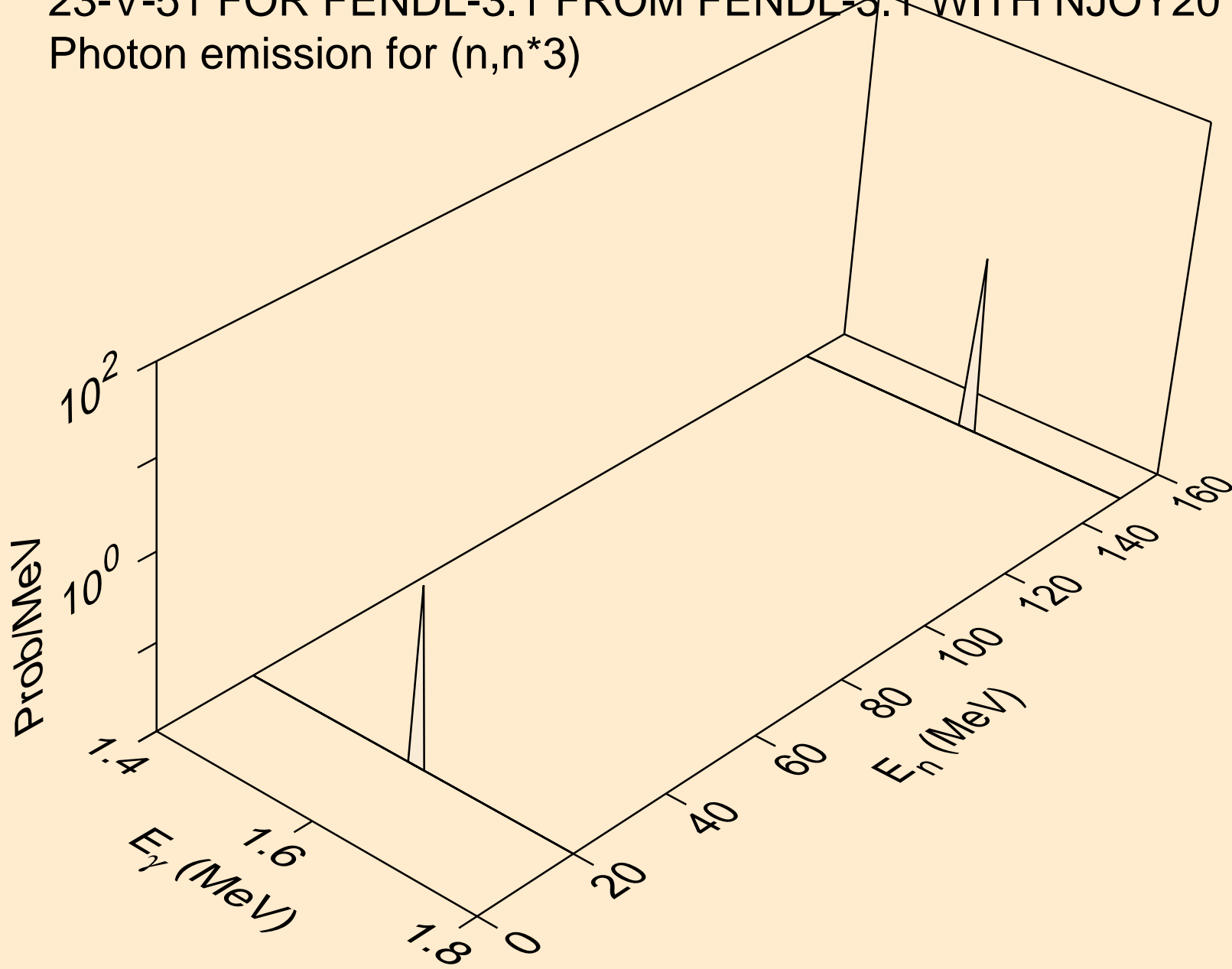

23-V-51 FOR FENDL-3.1 FROM FENDL-3.1 WITH NJOY2012.50+ C
Photon emission for (n,n*4)

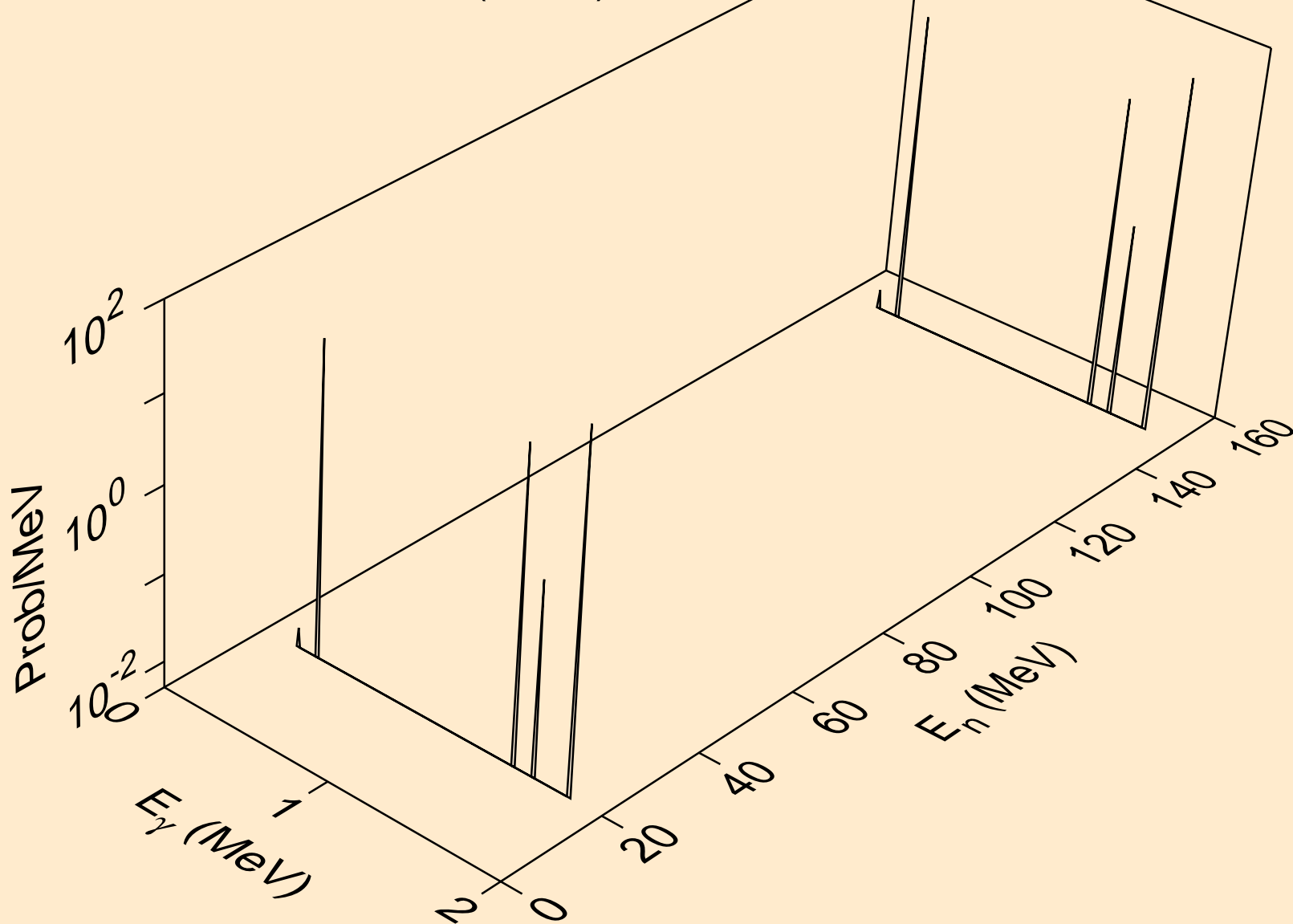

23-V-51 FOR FENDL-3.1 FROM FENDL-3.1 WITH NJOY2012.50+ C
Photon emission for (n,n*5)

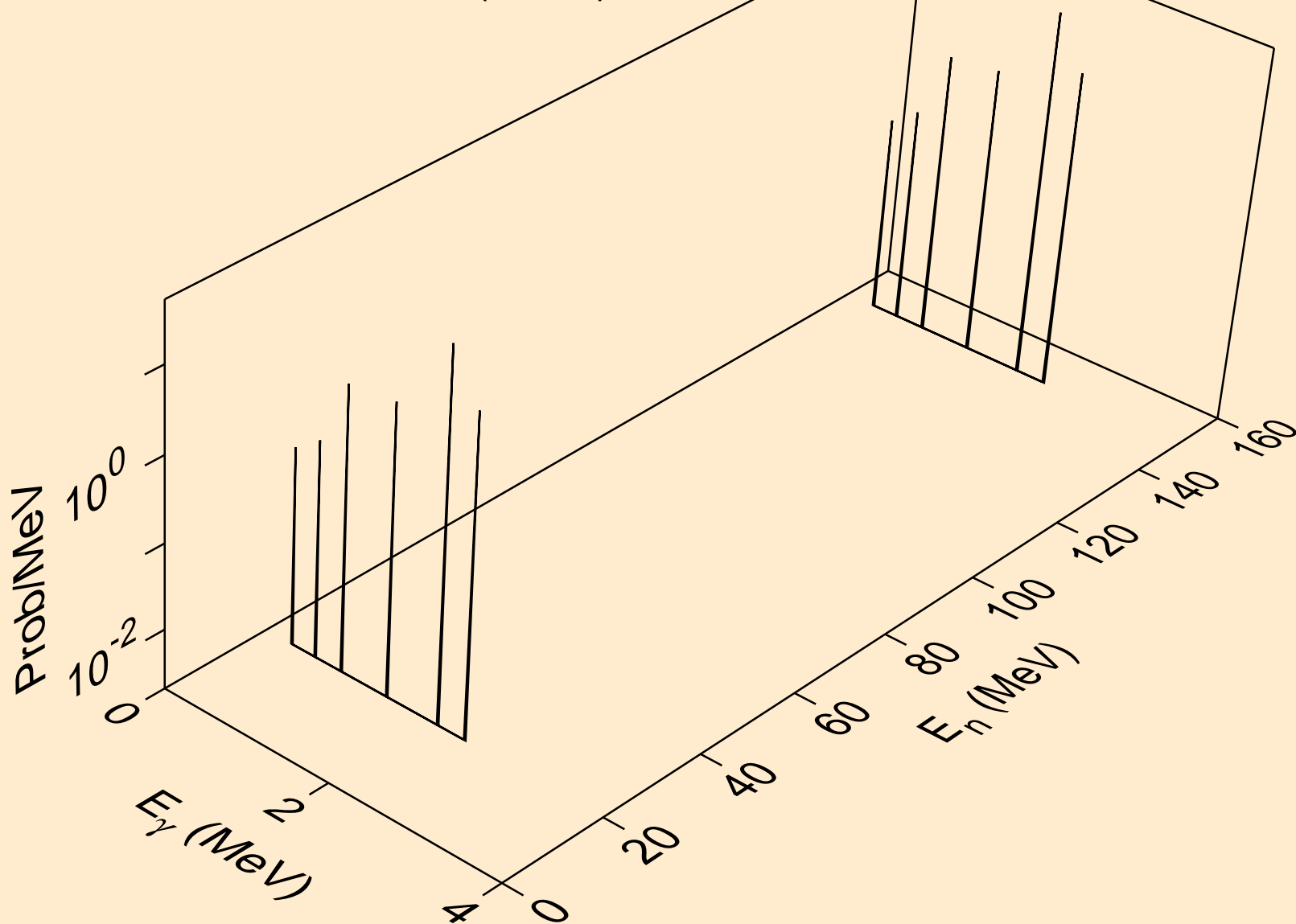

23-V-51 FOR FENDL-3.1 FROM FENDL-3.1 WITH NJOY2012.50+ C
Photon emission for (n,n*6)

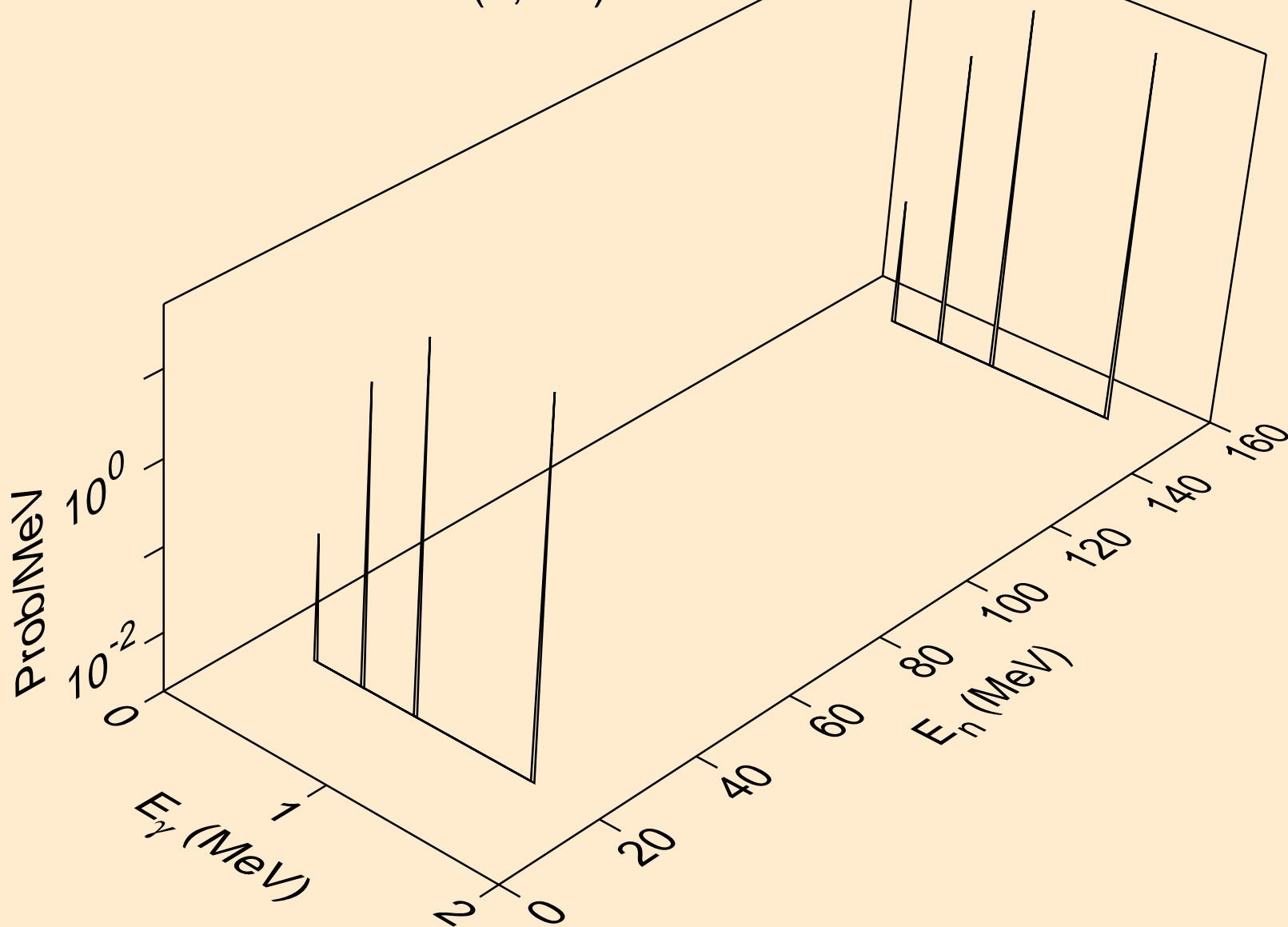

23-V-51 FOR FENDL-3.1 FROM FENDL-3.1 WITH NJOY2012.50+ C
Photon emission for (n,n*7)

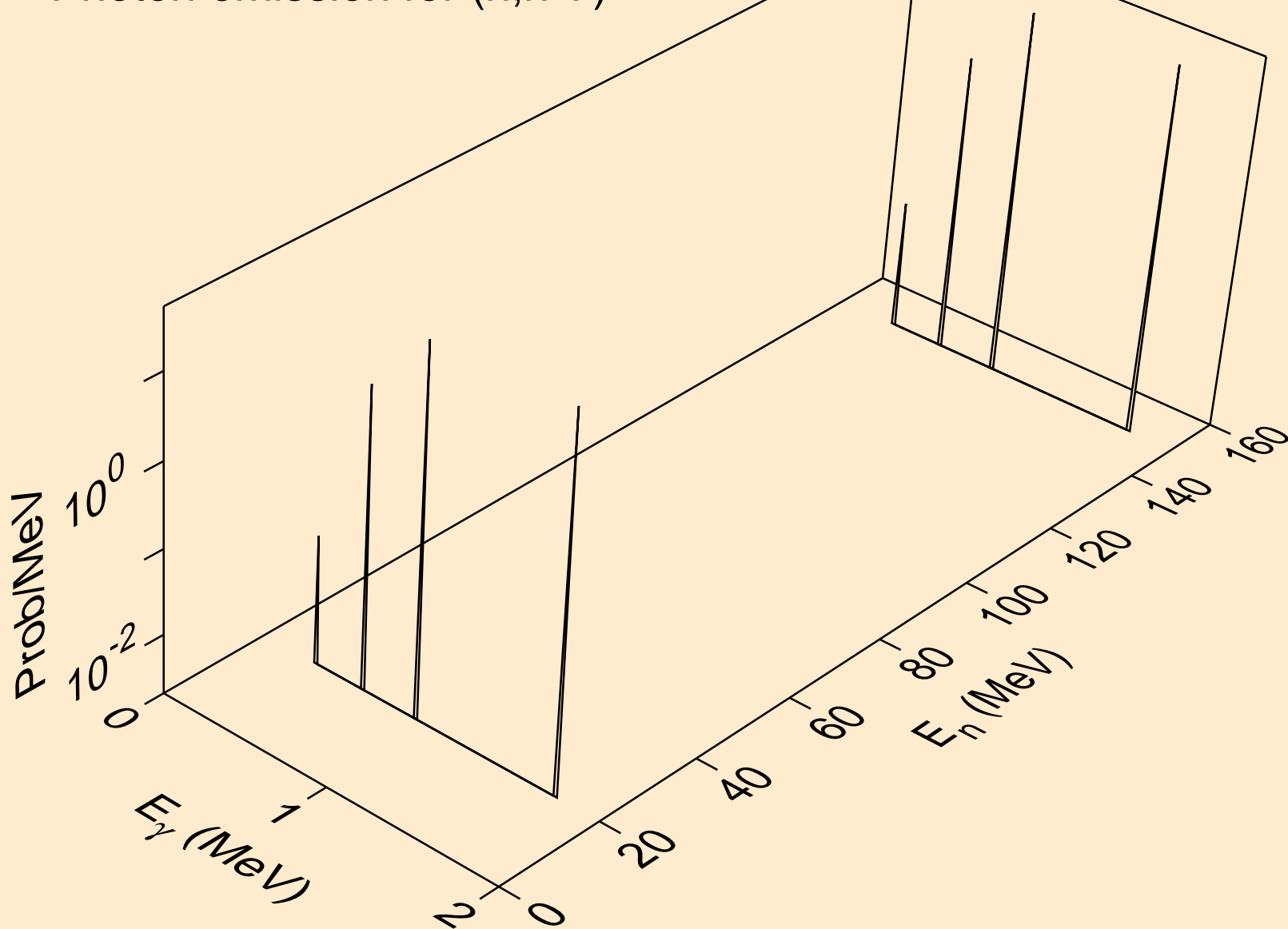

23-V-51 FOR FENDL-3.1 FROM FENDL-3.1 WITH NJOY2012.50+ C
Photon emission for (n,n*8)

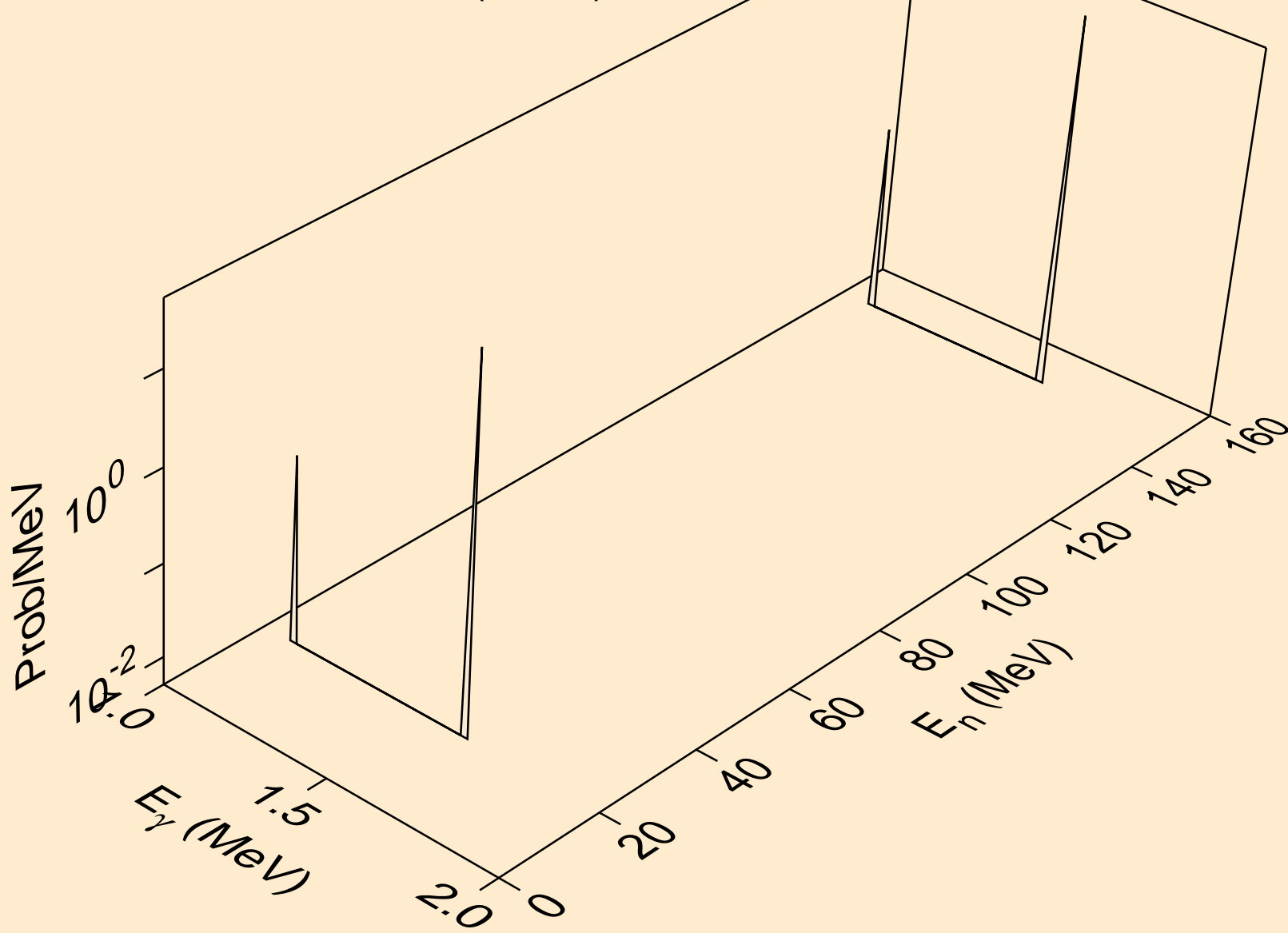

23-V-51 FOR FENDL-3.1 FROM FENDL-3.1 WITH NJOY2012.50+ C
Photon emission for (n,n*9)

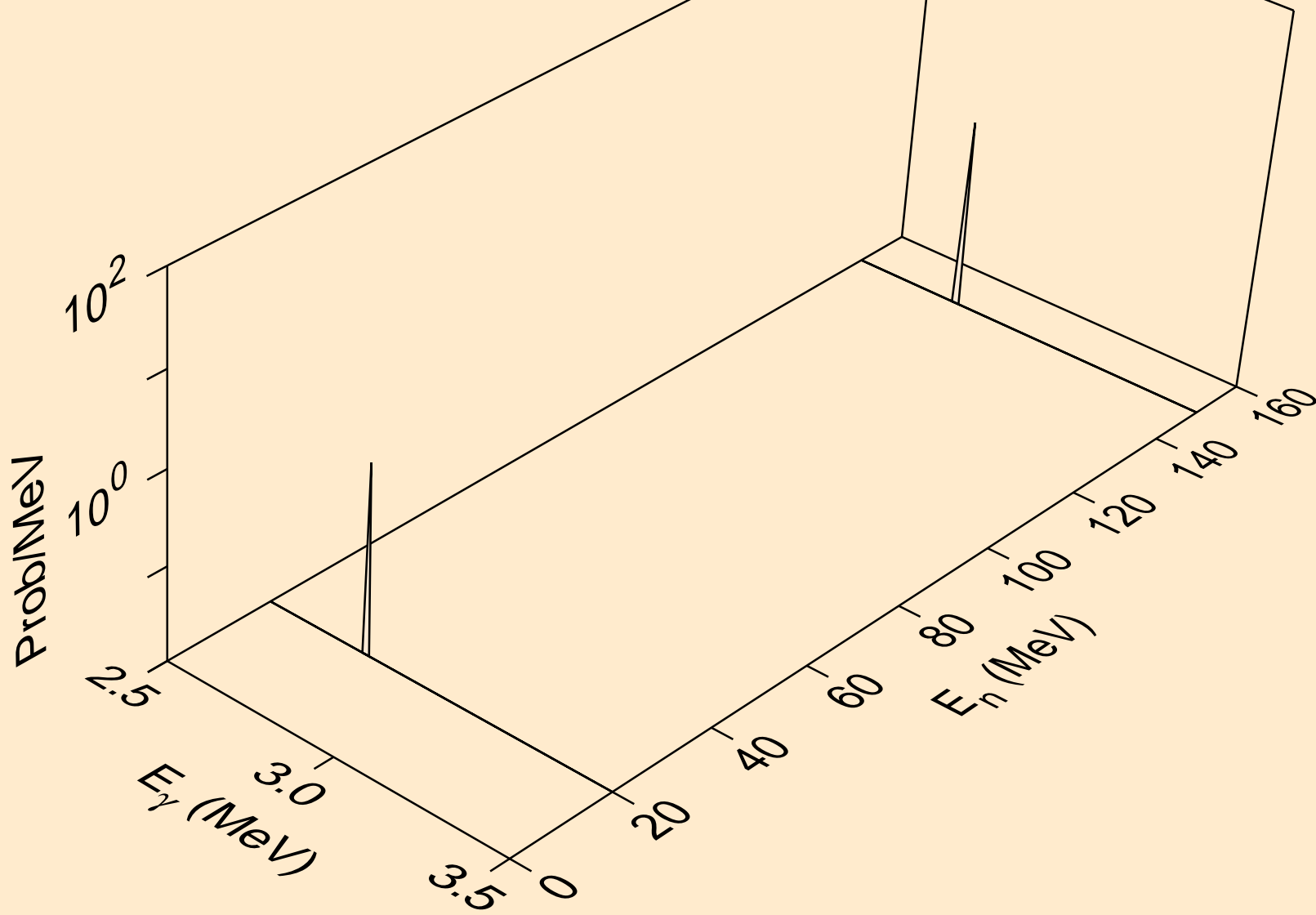

23-V-51 FOR FENDL-3.1 FROM FENDL-3.1 WITH NJOY2012.50+ C
Photon emission for (n,n*10)

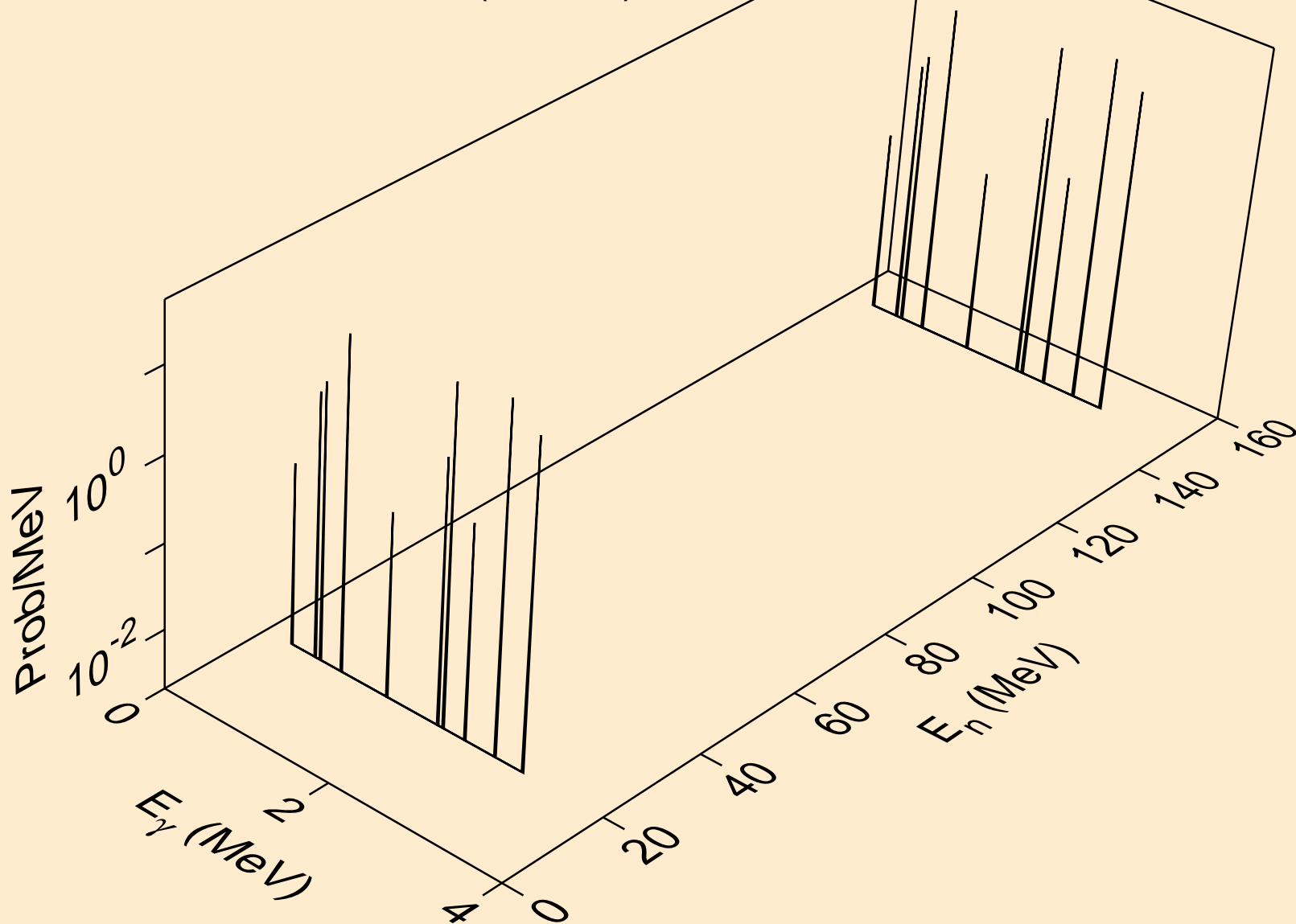

23-V-51 FOR FENDL-3.1 FROM FENDL-3.1 WITH NJOY2012.50+ C
Photon emission for (n,n*11)

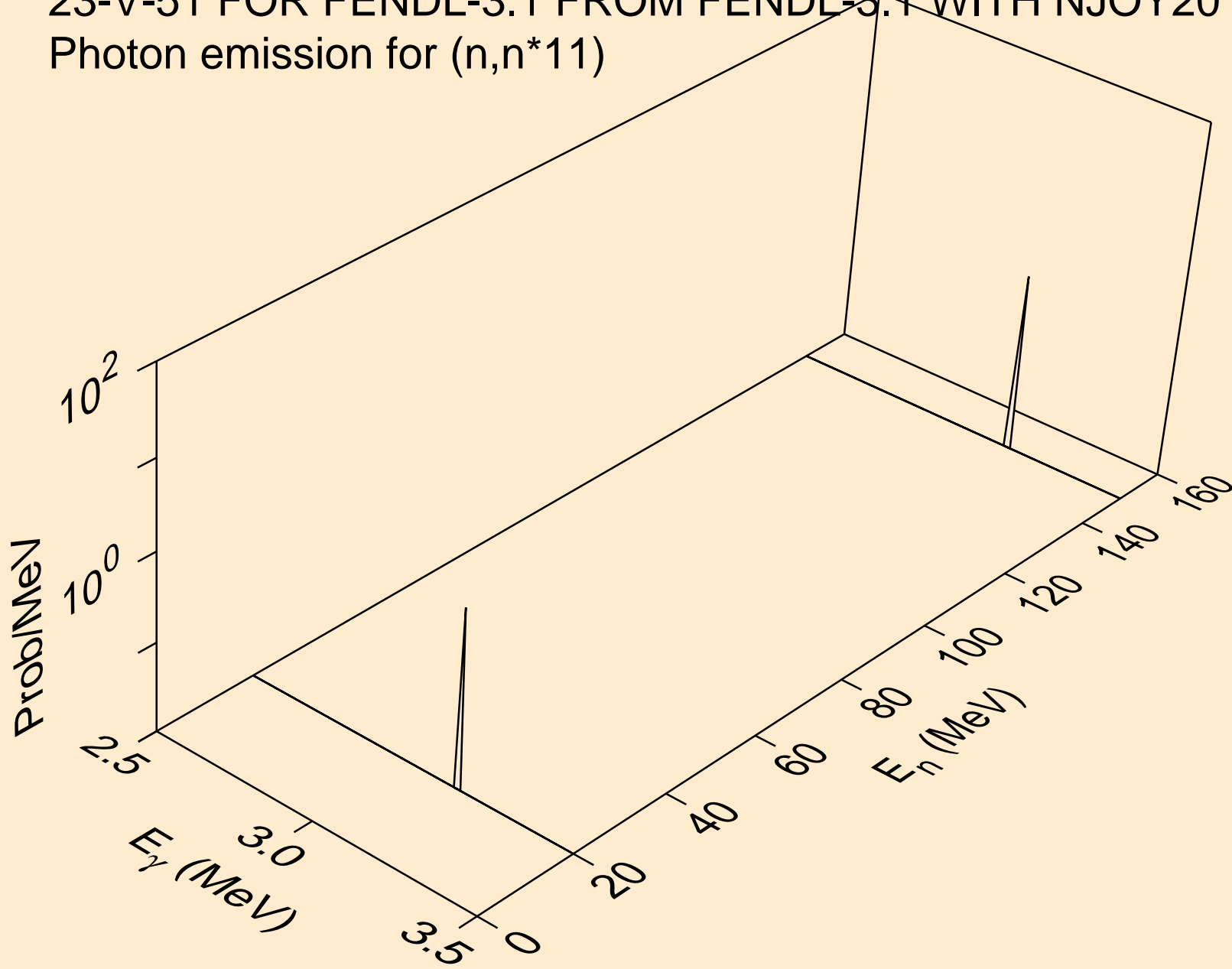

23-V-51 FOR FENDL-3.1 FROM FENDL-3.1 WITH NJOY2012.50+ C
Photon emission for (n,n*12)

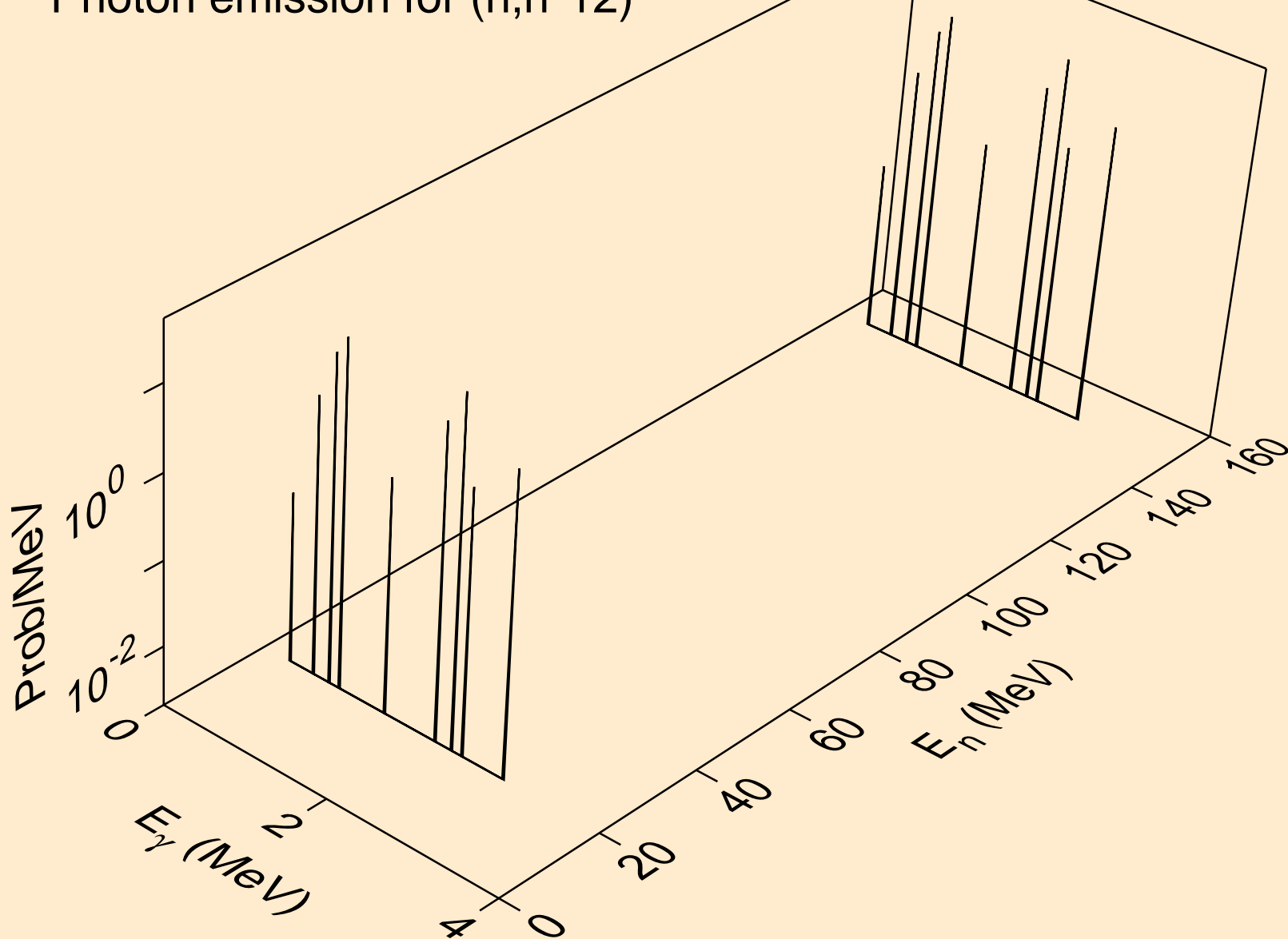

23-V-51 FOR FENDL-3.1 FROM FENDL-3.1 WITH NJOY2012.50+ C
Photon emission for (n,n*13)

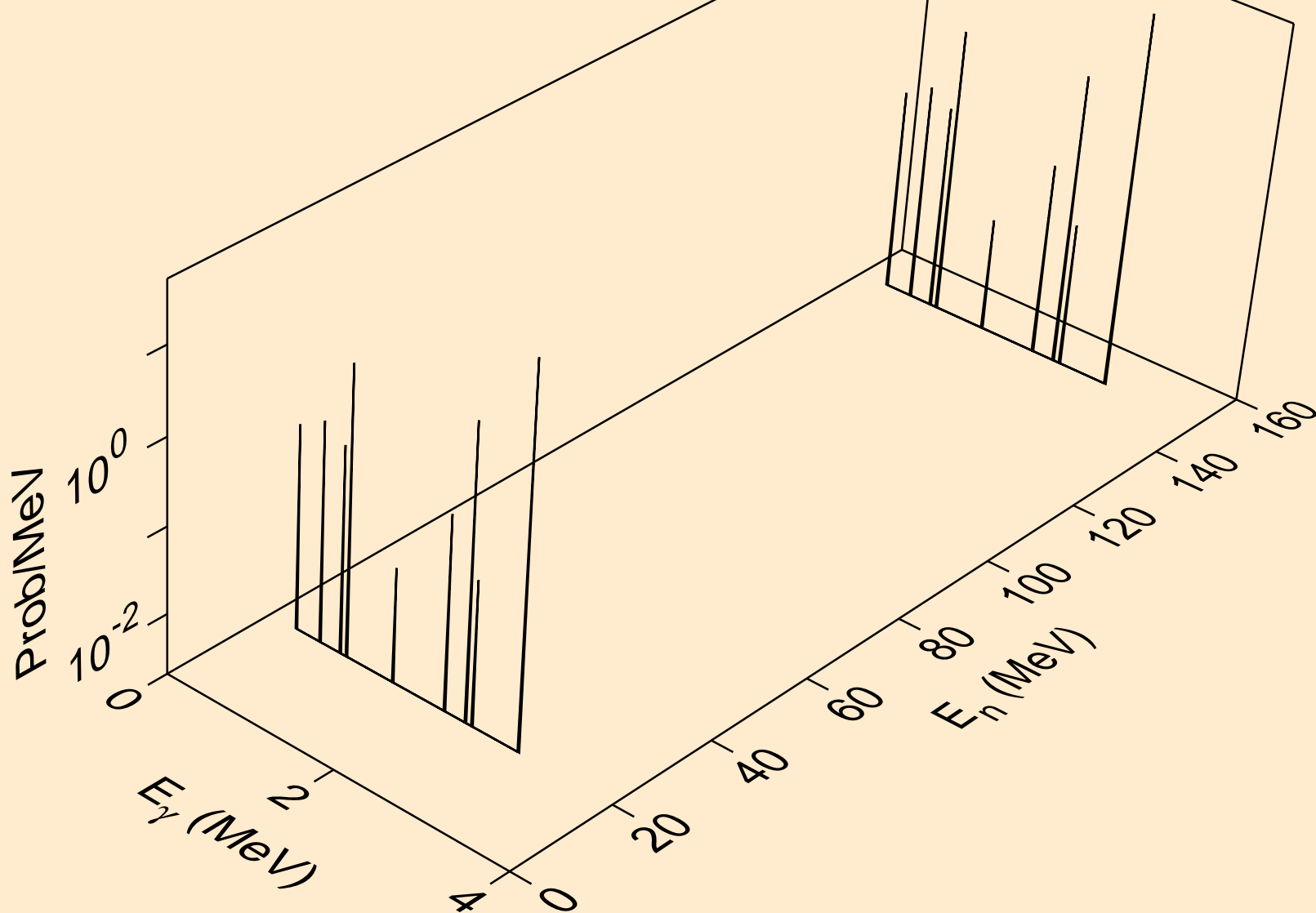

23-V-51 FOR FENDL-3.1 FROM FENDL-3.1 WITH NJOY2012.50+ C
Photon emission for (n,n*14)

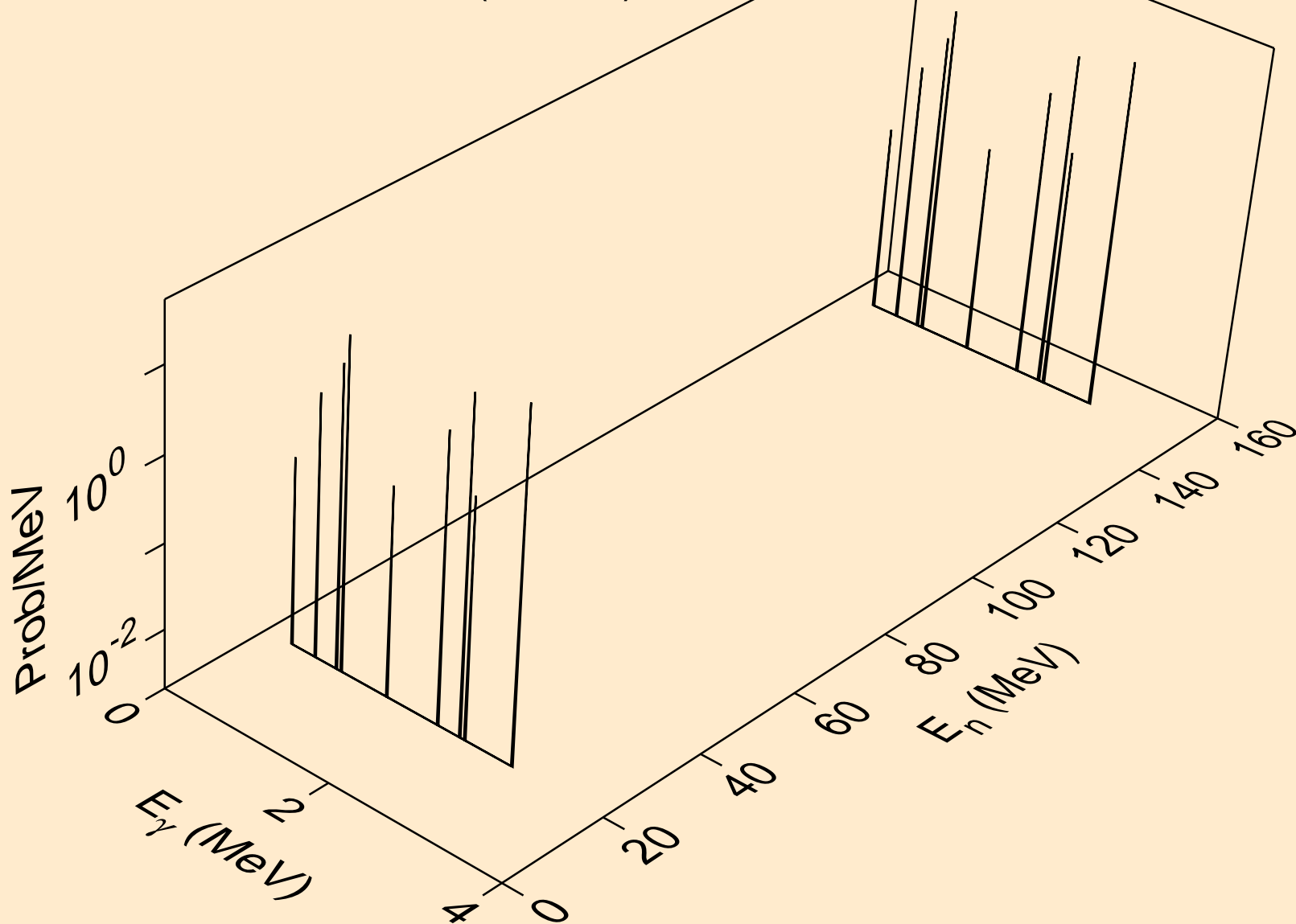

23-V-51 FOR FENDL-3.1 FROM FENDL-3.1 WITH NJOY2012.50+ C
Photon emission for (n,n*15)

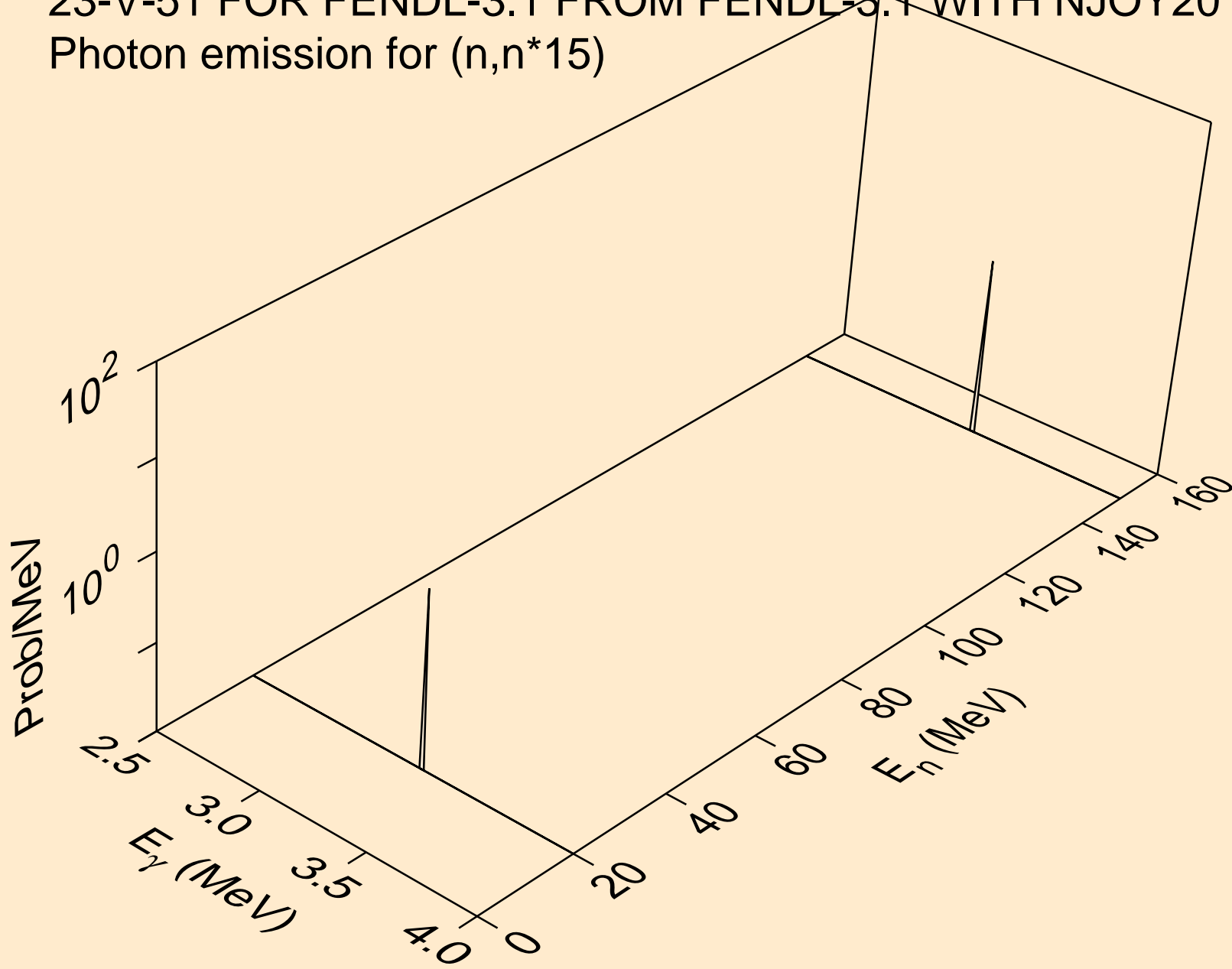

23-V-51 FOR FENDL-3.1 FROM FENDL-3.1 WITH NJOY2012.50+ C
Photon emission for (n,n*16)

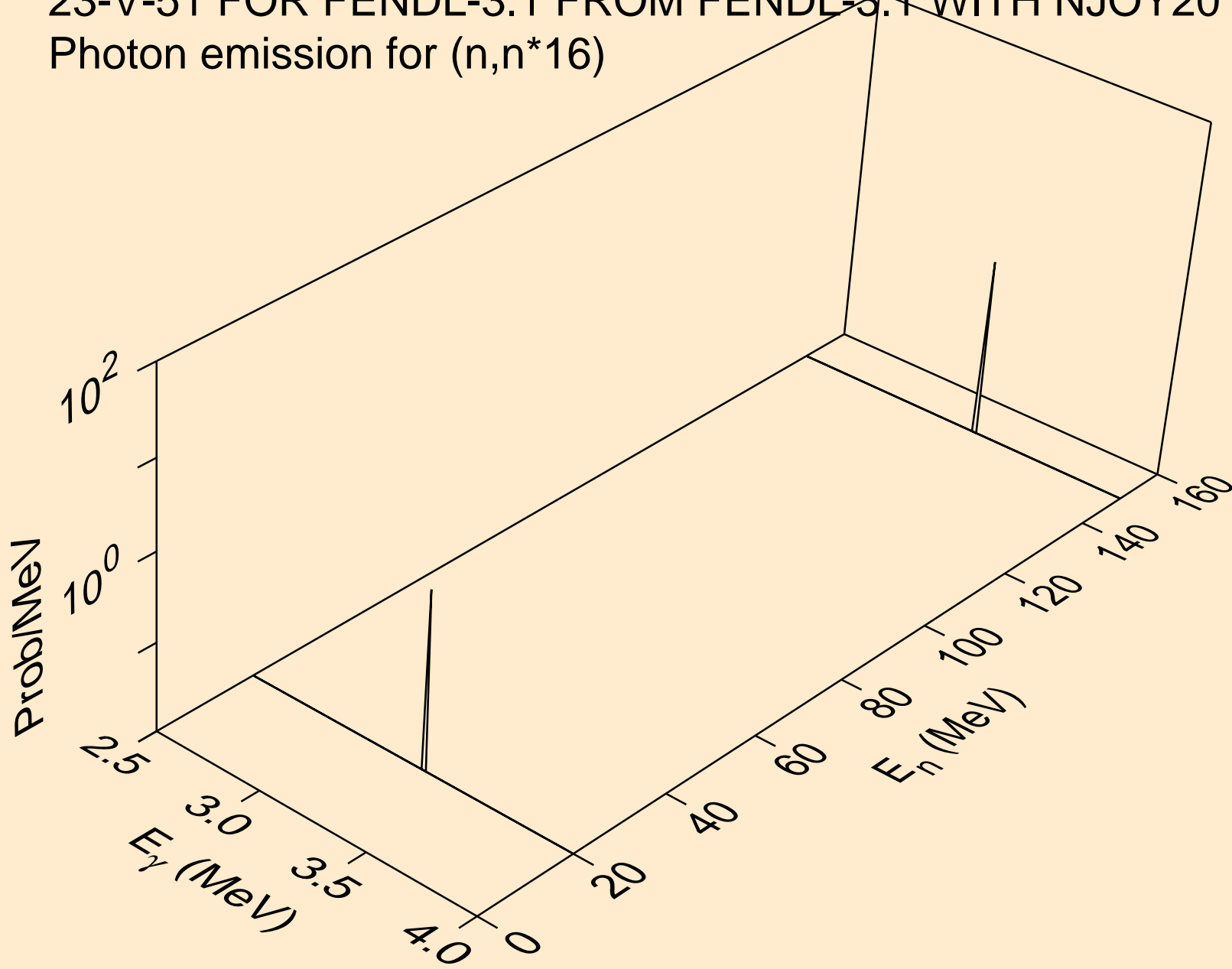

23-V-51 FOR FENDL-3.1 FROM FENDL-3.1 WITH NJOY2012.50+ C
Photon emission for (n,n*17)

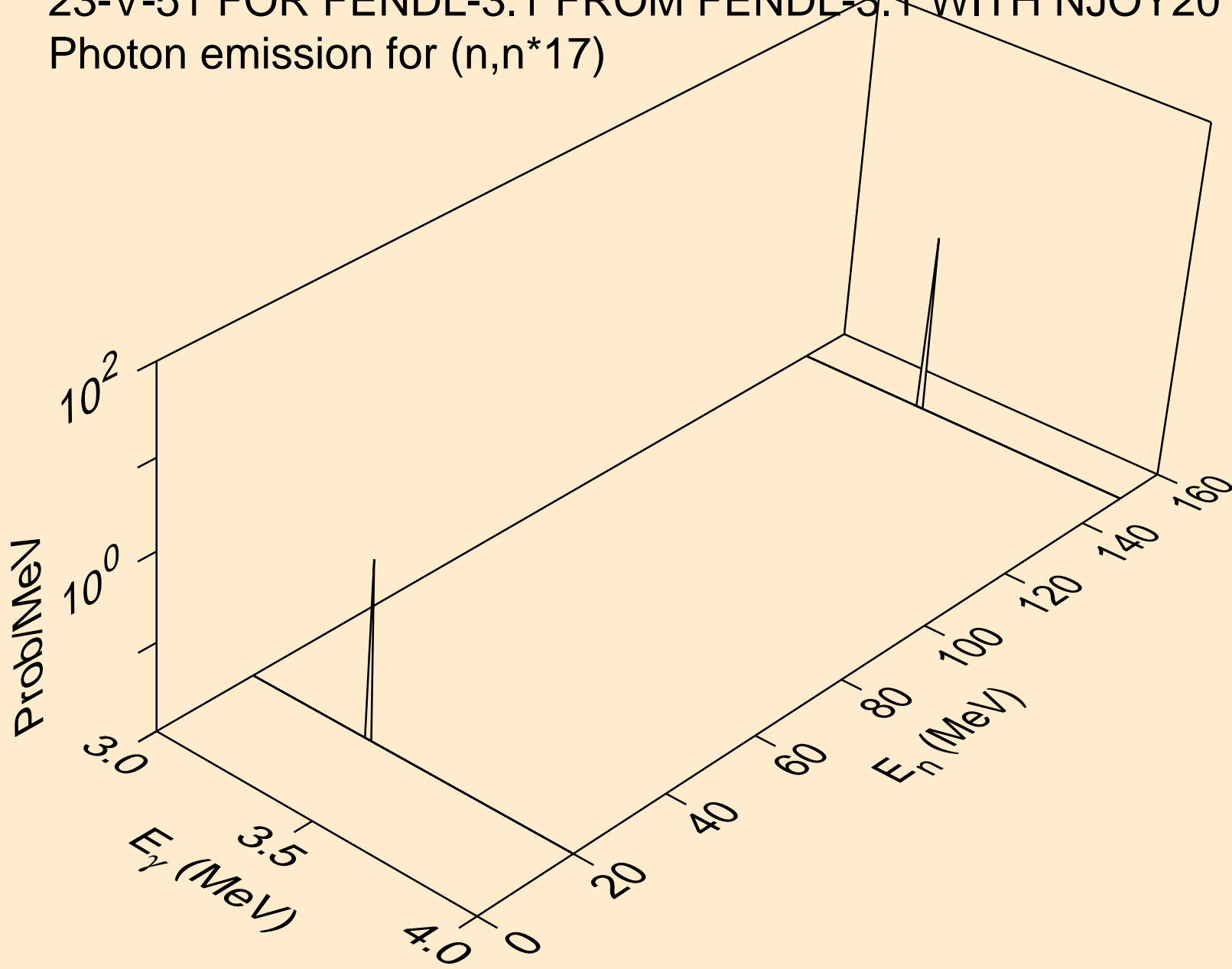

23-V-51 FOR FENDL-3.1 FROM FENDL-3.1 WITH NJOY2012.50+ C
Photon emission for (n,n*18)

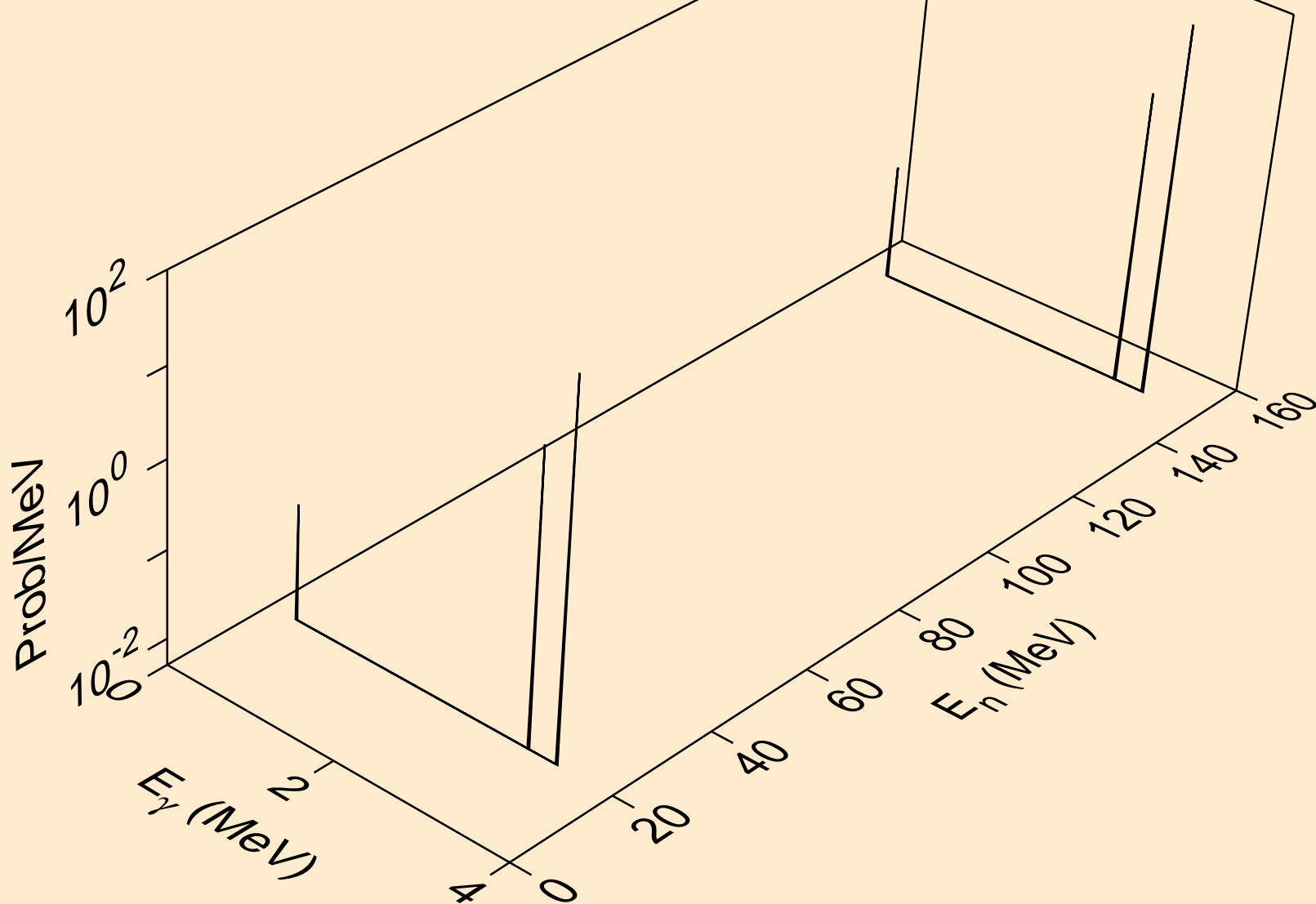

23-V-51 FOR FENDL-3.1 FROM FENDL-3.1 WITH NJOY2012.50+ C
Photon emission for (n,n*19)

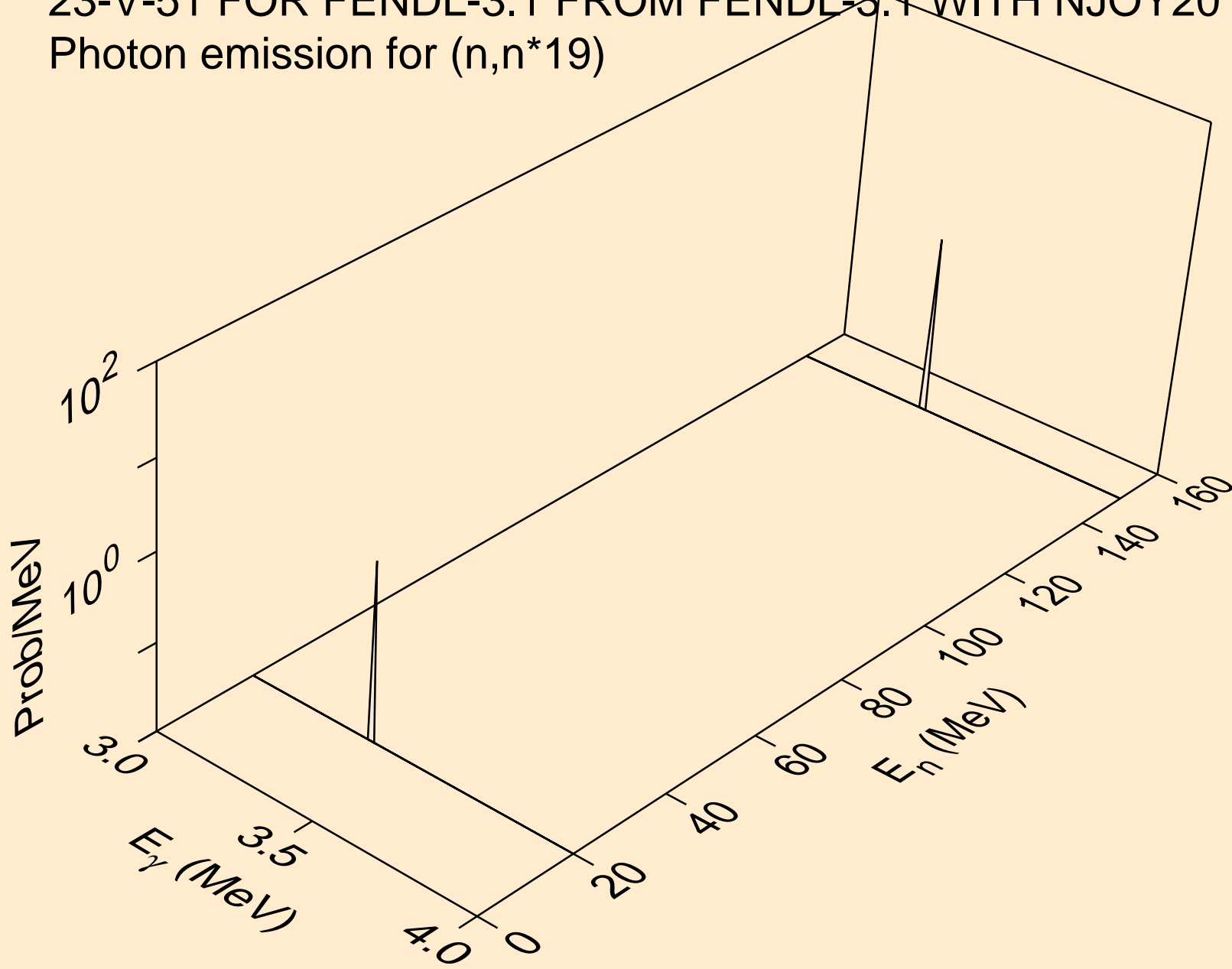

23-V-51 FOR FENDL-3.1 FROM FENDL-3.1 WITH NJOY2012.50+ C
Photon emission for (n,n*20)

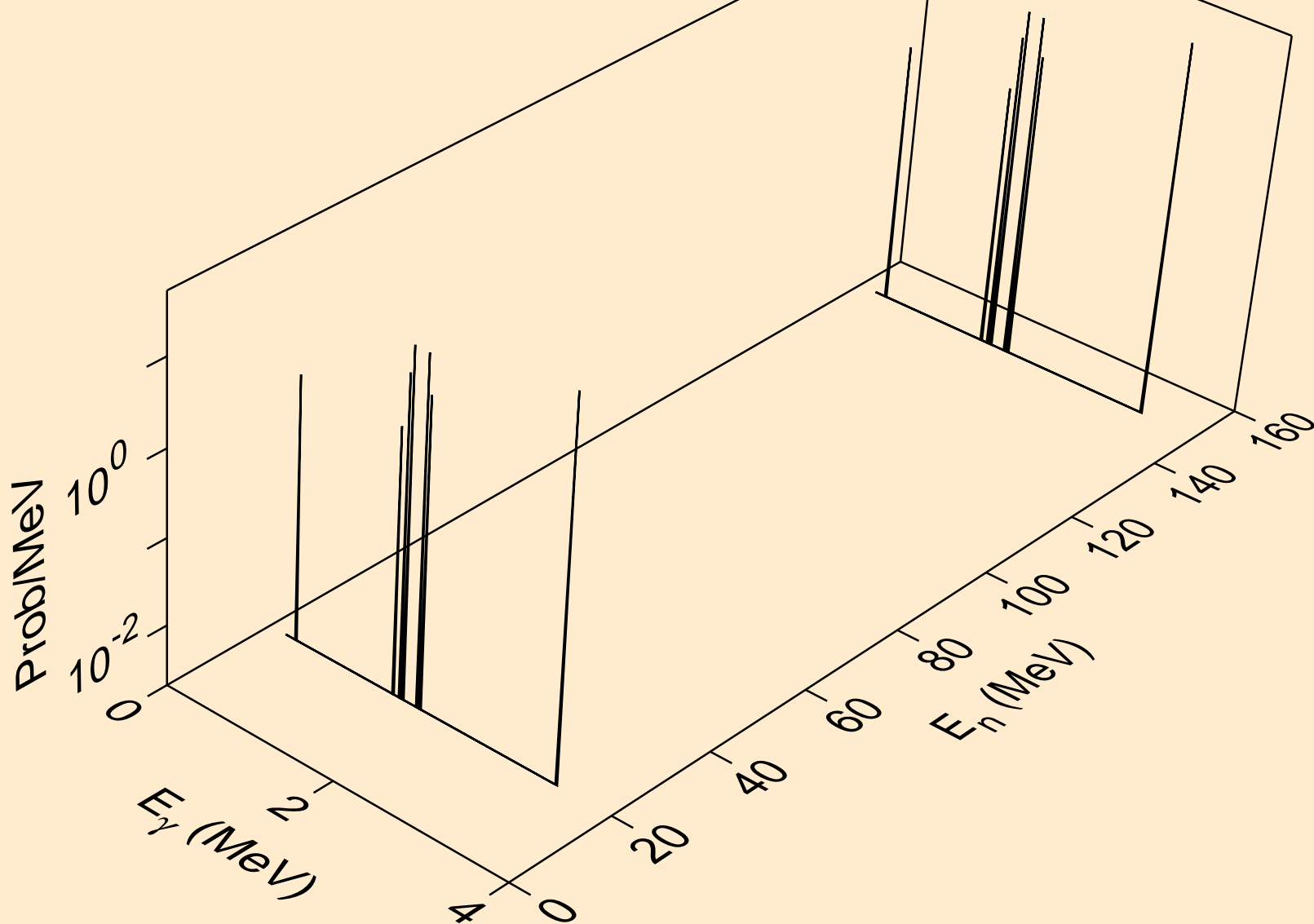

23-V-51 FOR FENDL-3.1 FROM FENDL-3.1 WITH NJOY2012.50+ C
Photon emission for (n,n*21)

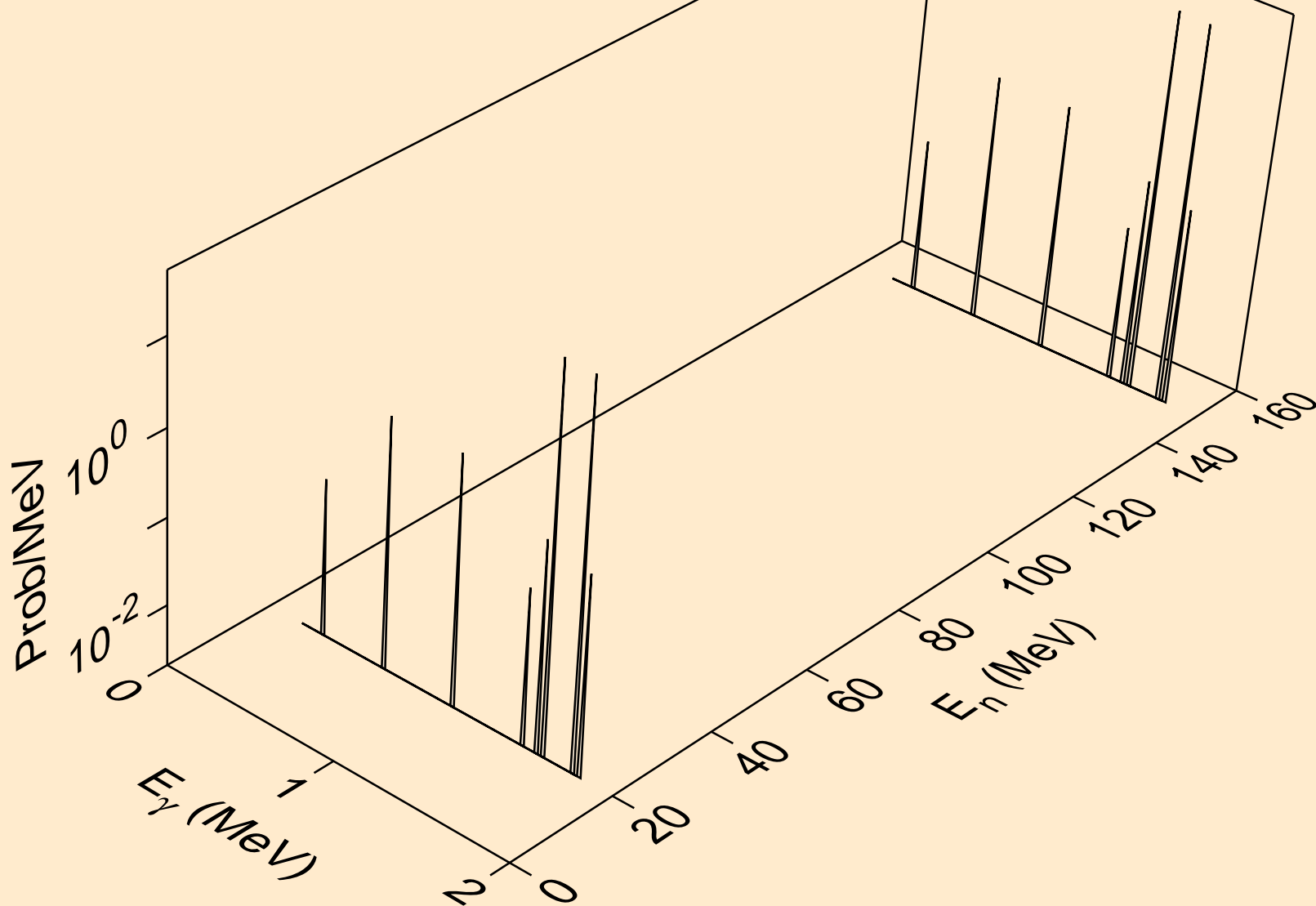

23-V-51 FOR FENDL-3.1 FROM FENDL-3.1 WITH NJOY2012.50+ C
Photon emission for (n,n*22)

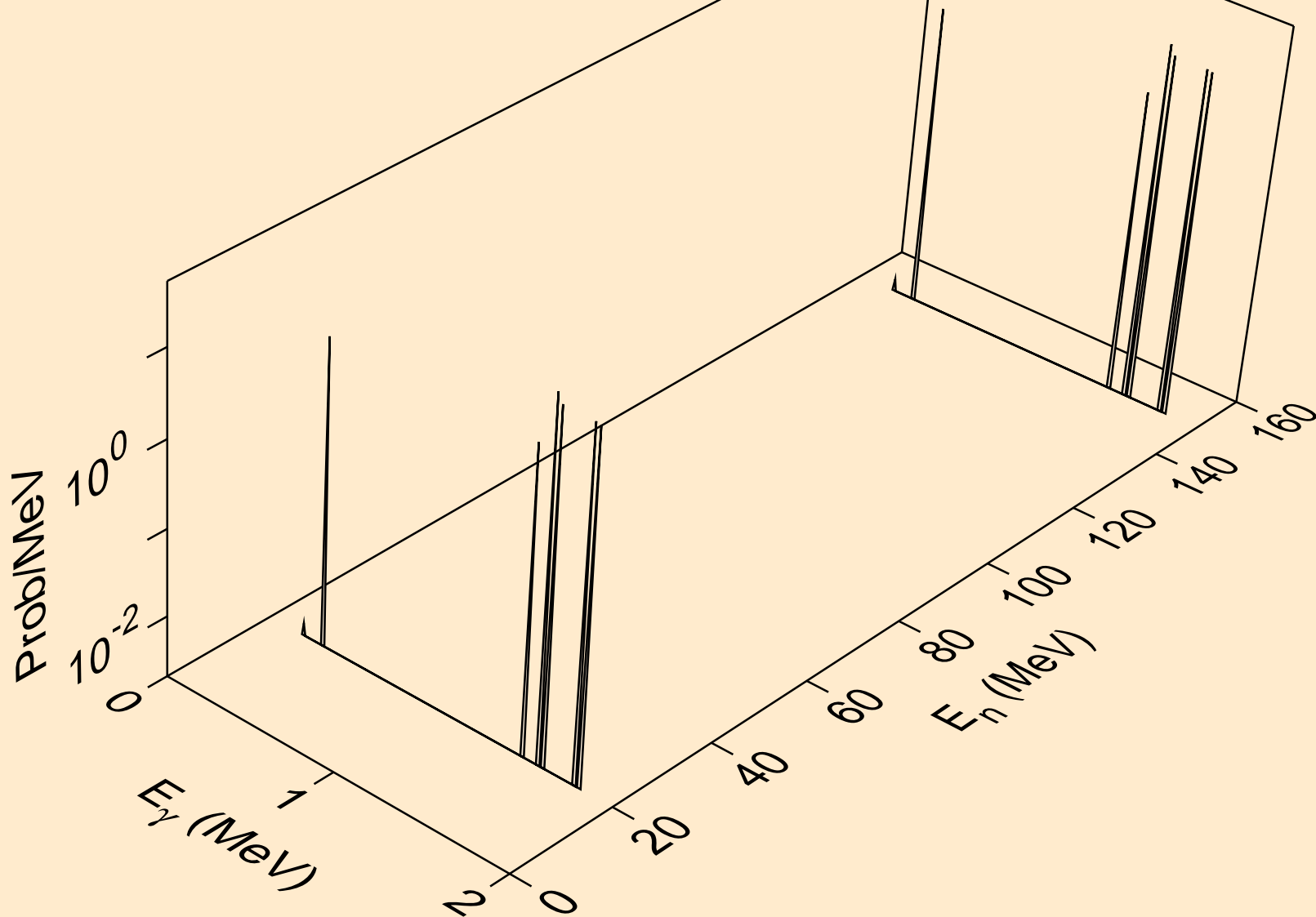

23-V-51 FOR FENDL-3.1 FROM FENDL-3.1 WITH NJOY2012.50+ C
Photon emission for (n,n*23)

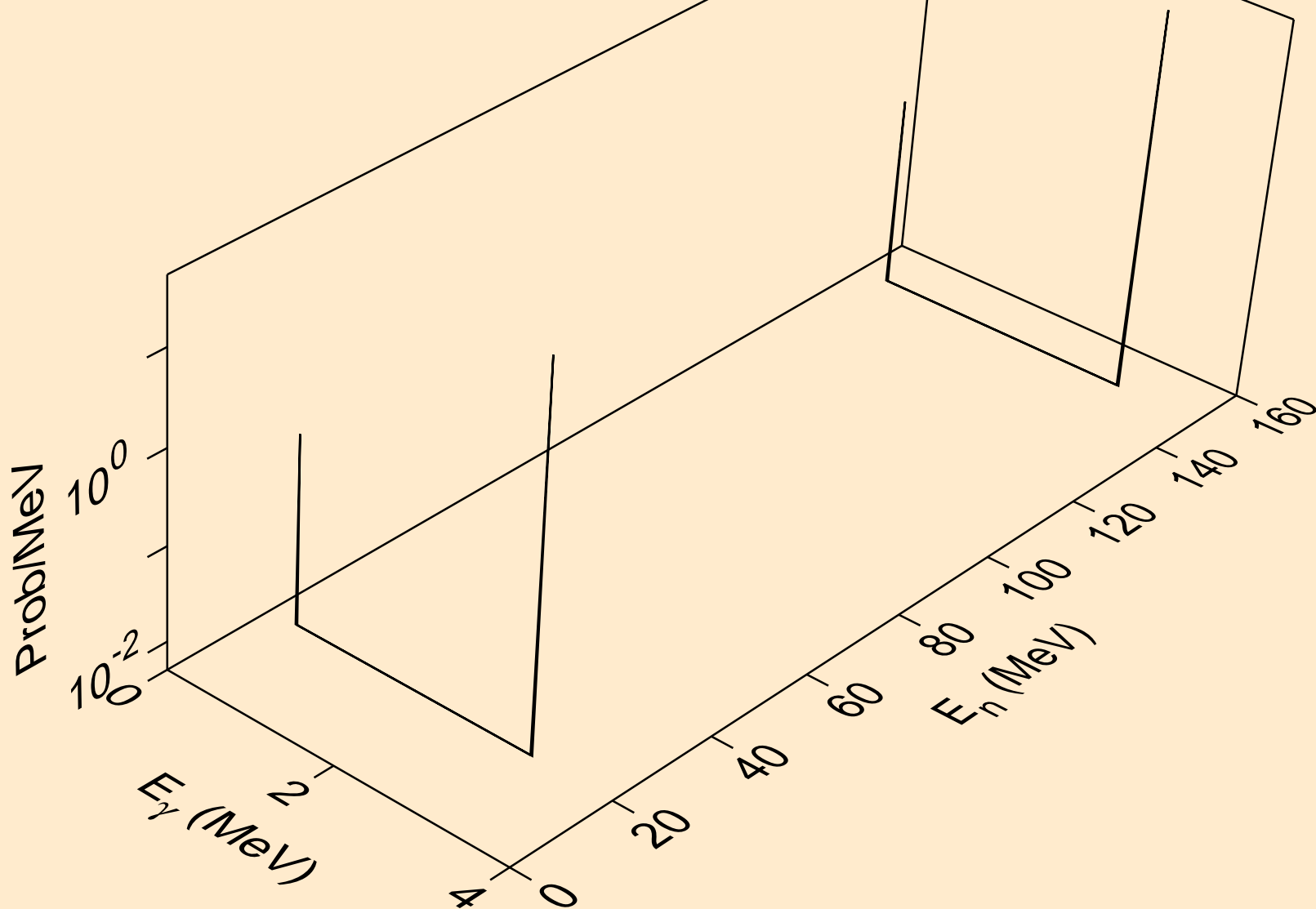

23-V-51 FOR FENDL-3.1 FROM FENDL-3.1 WITH NJOY2012.50+ C
Photon emission for (n,n*24)

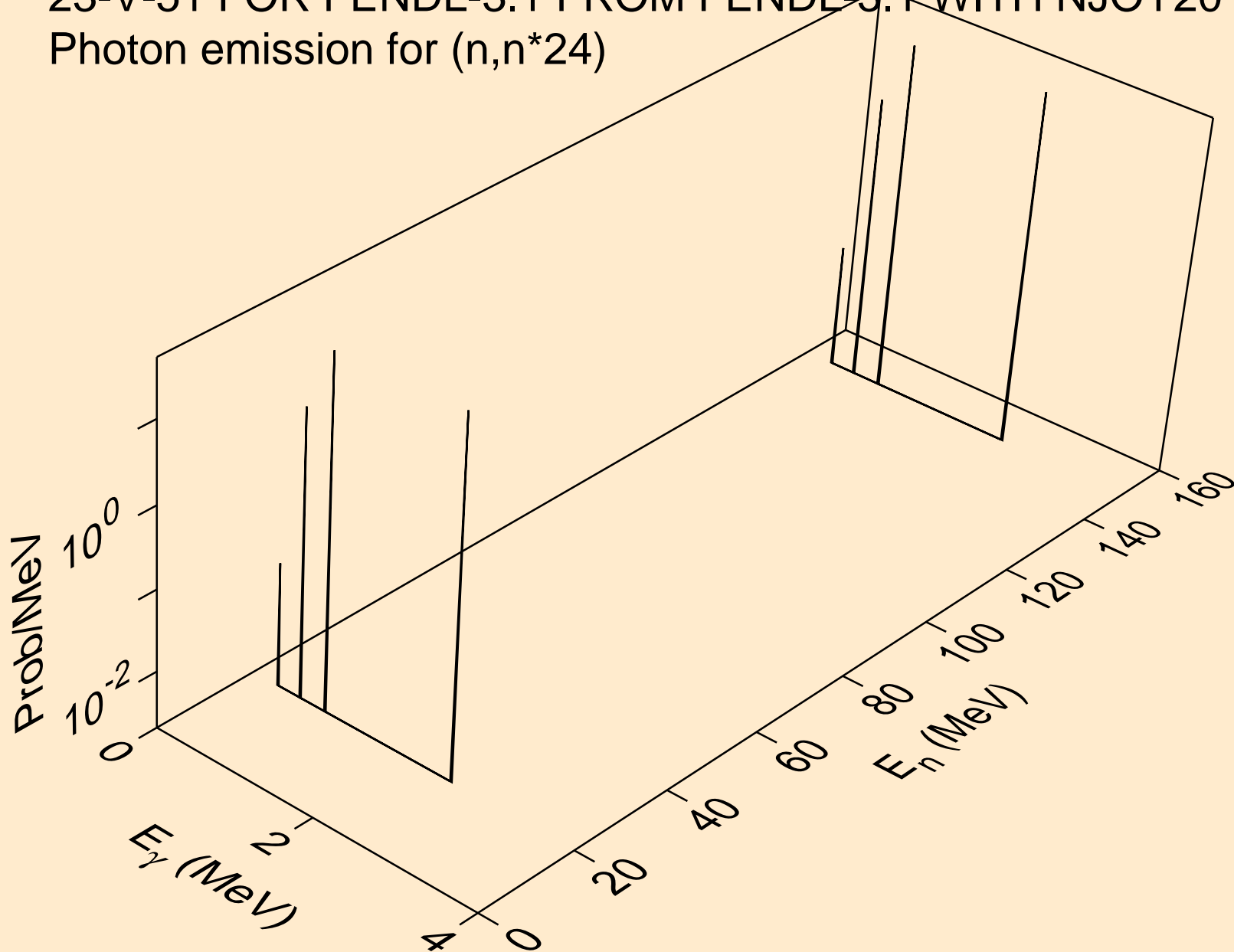

23-V-51 FOR FENDL-3.1 FROM FENDL-3.1 WITH NJOY2012.50+ C
Photon emission for (n,n*25)

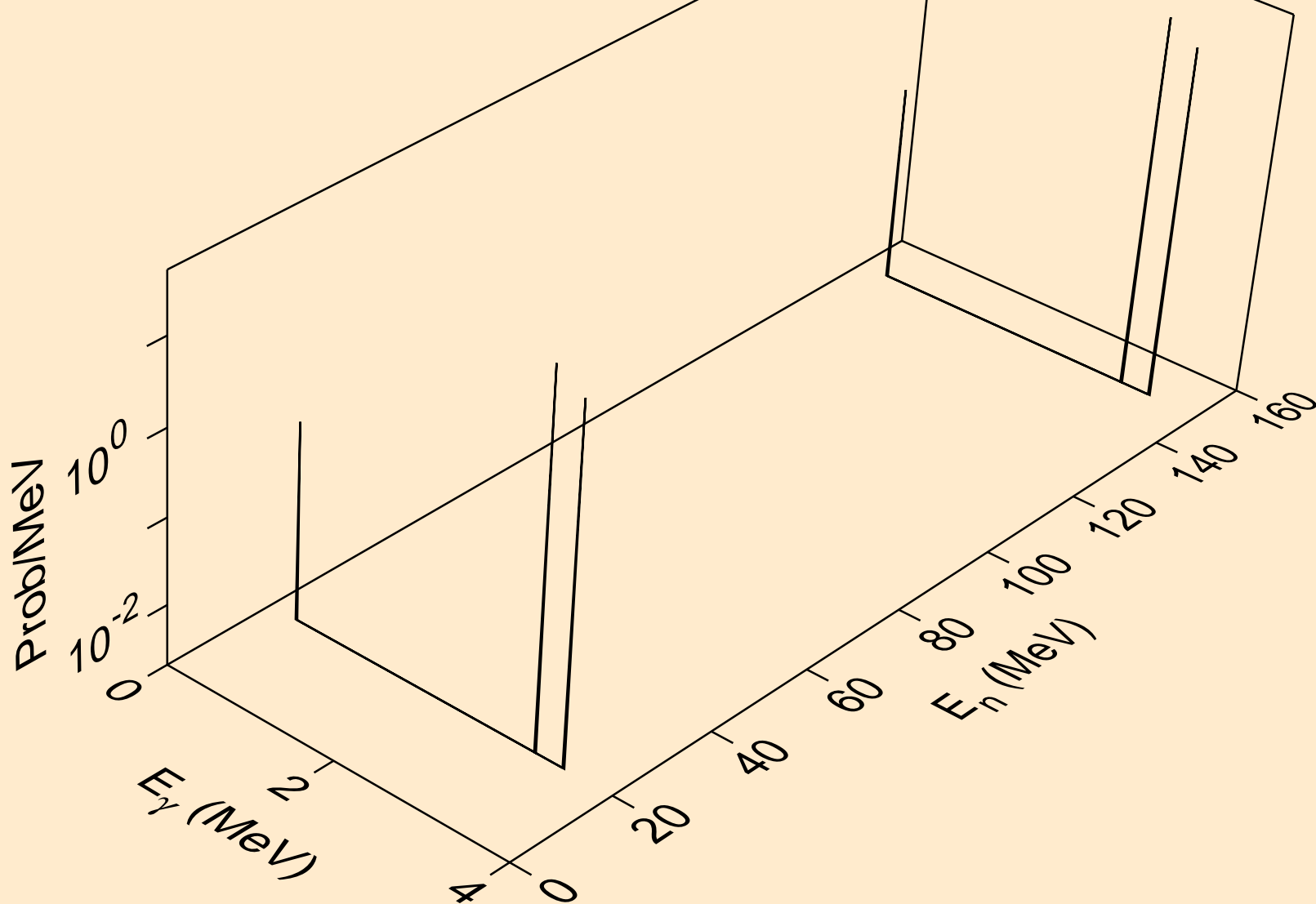

23-V-51 FOR FENDL-3.1 FROM FENDL-3.1 WITH NJOY2012.50+ C
Photon emission for (n,n*26)

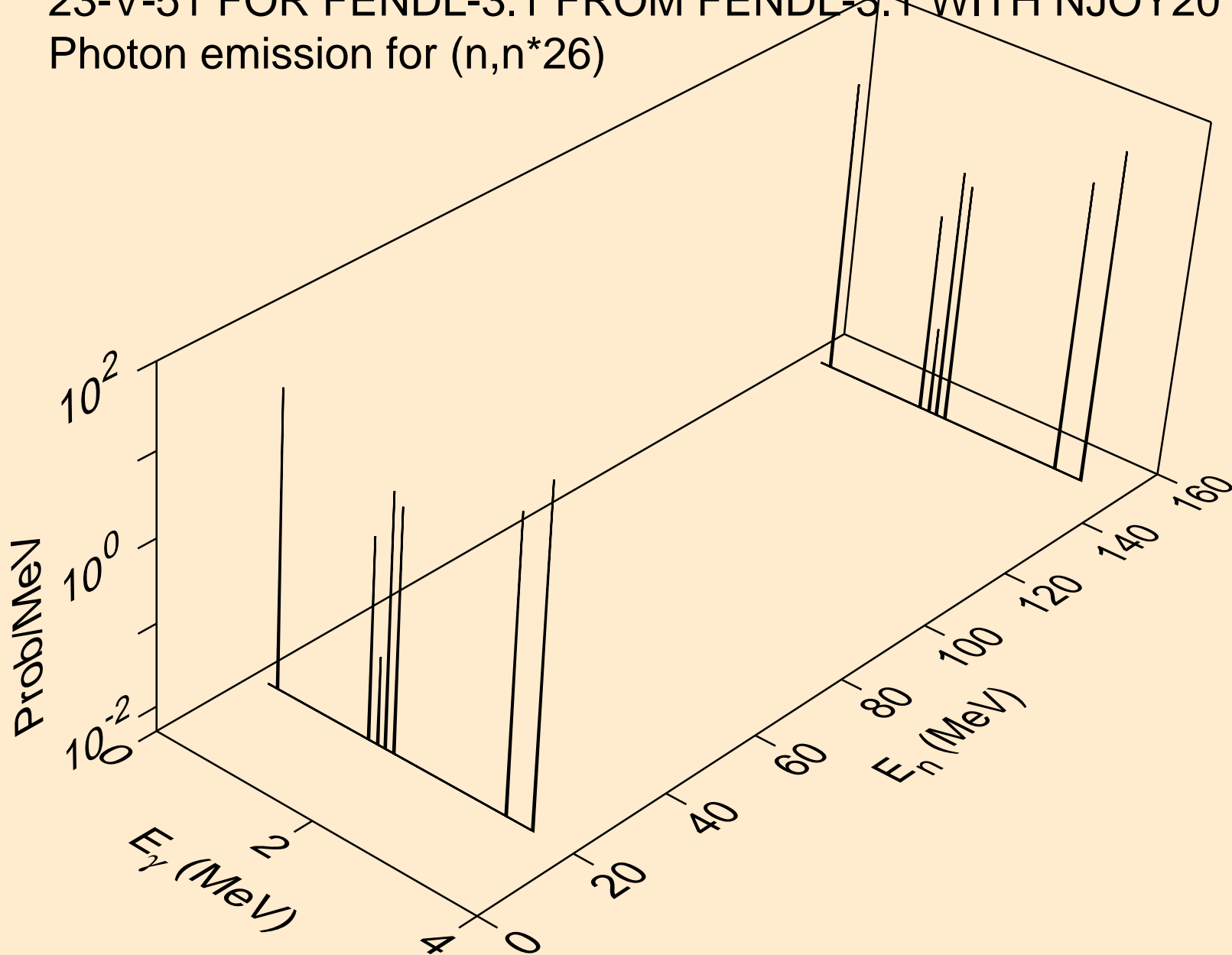

23-V-51 FOR FENDL-3.1 FROM FENDL-3.1 WITH NJOY2012.50+ C
Photon emission for (n,n*27)

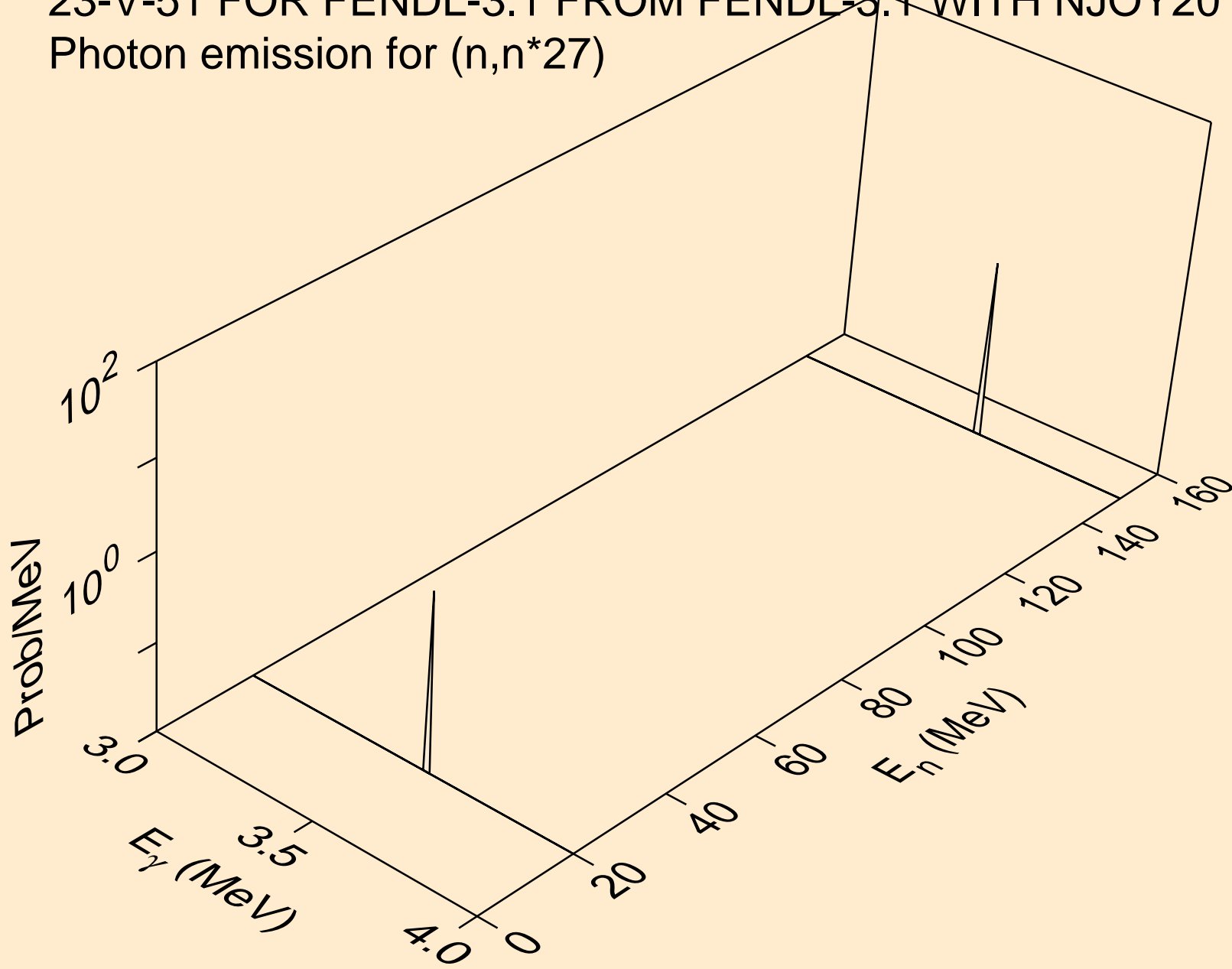

23-V-51 FOR FENDL-3.1 FROM FENDL-3.1 WITH NJOY2012.50+ C
Photon emission for (n,n*28)

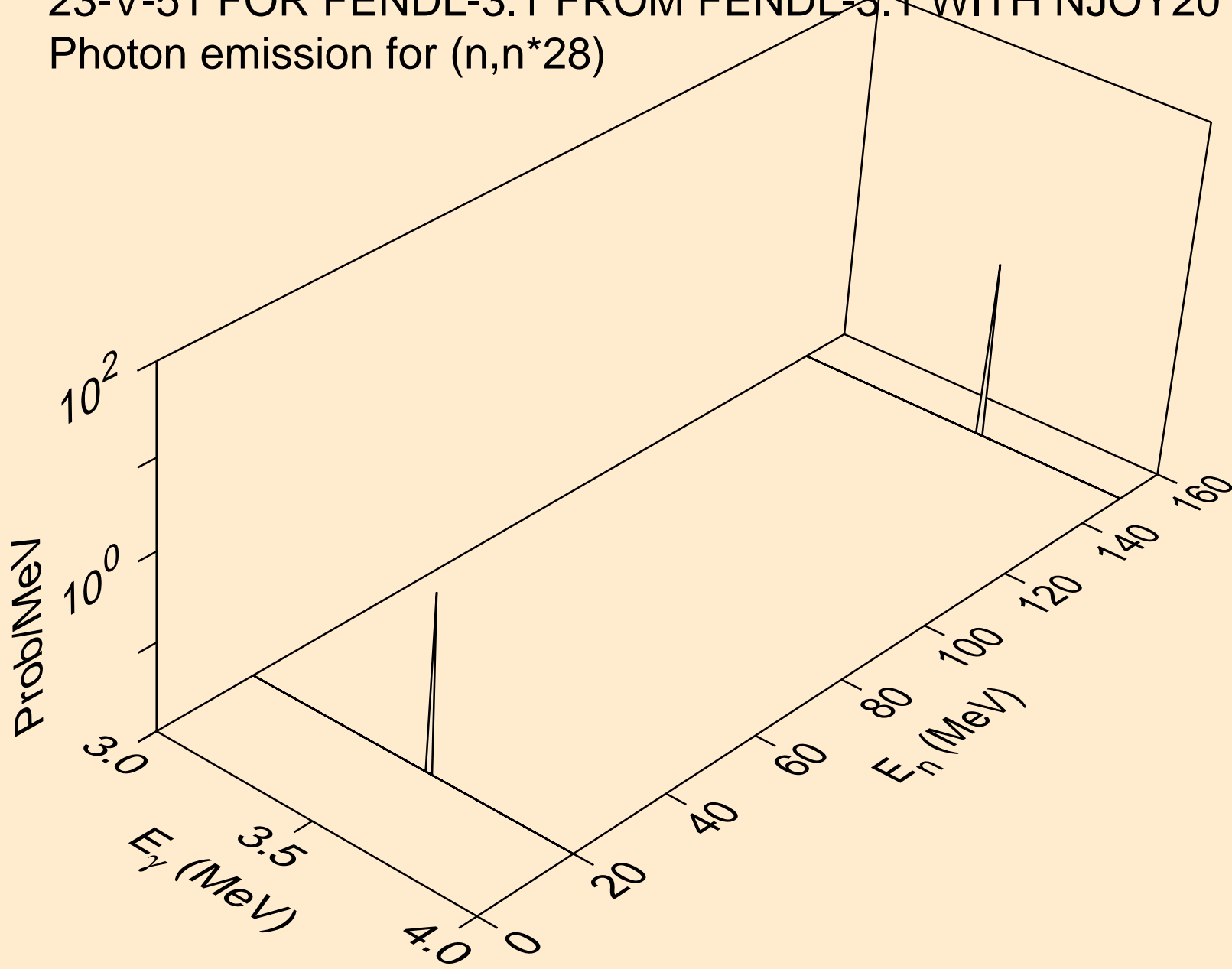

23-V-51 FOR FENDL-3.1 FROM FENDL-3.1 WITH NJOY2012.50+ C
Photon emission for (n,n*29)

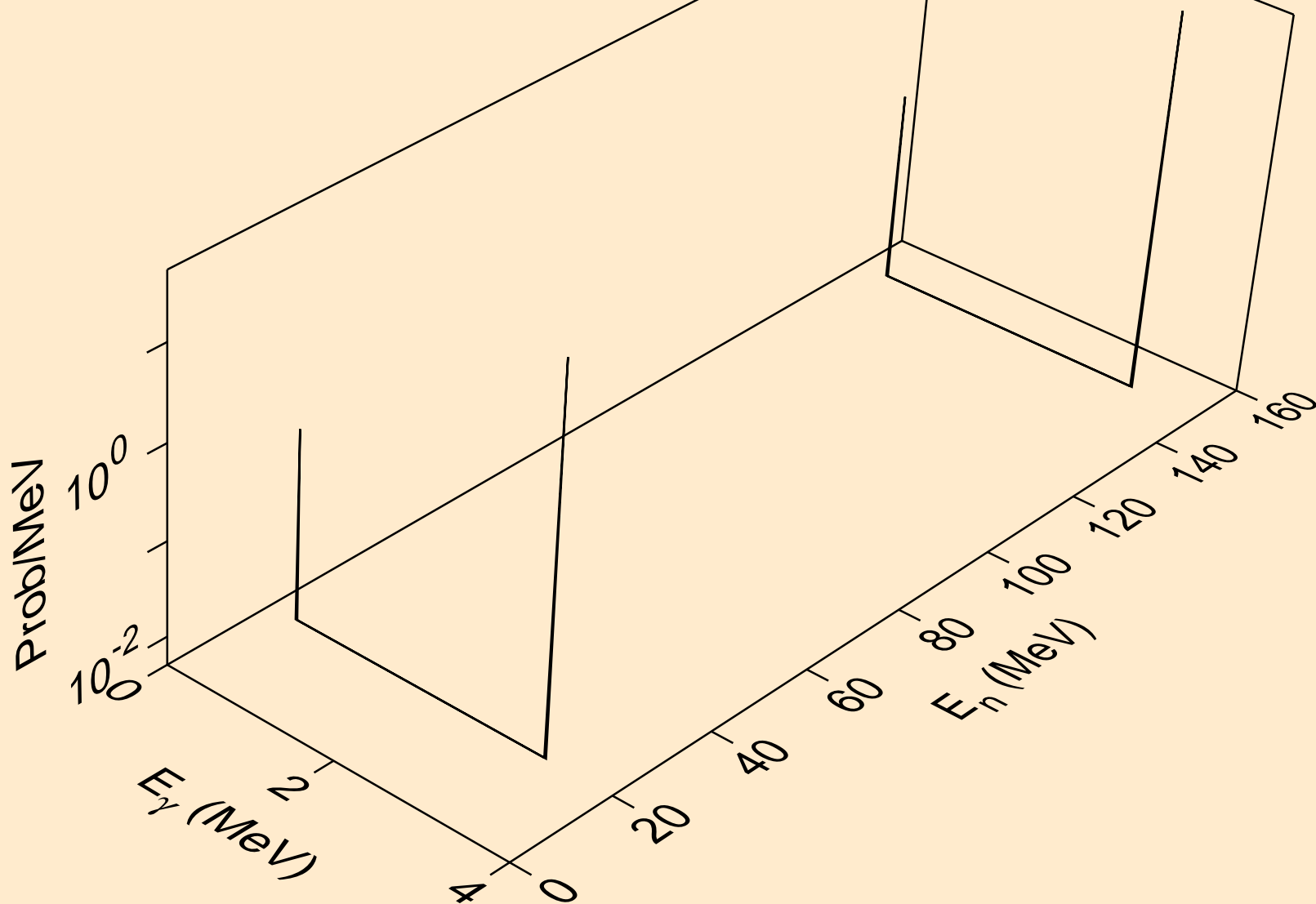

23-V-51 FOR FENDL-3.1 FROM FENDL-3.1 WITH NJOY2012.50+ C
Photon emission for (n,n*30)

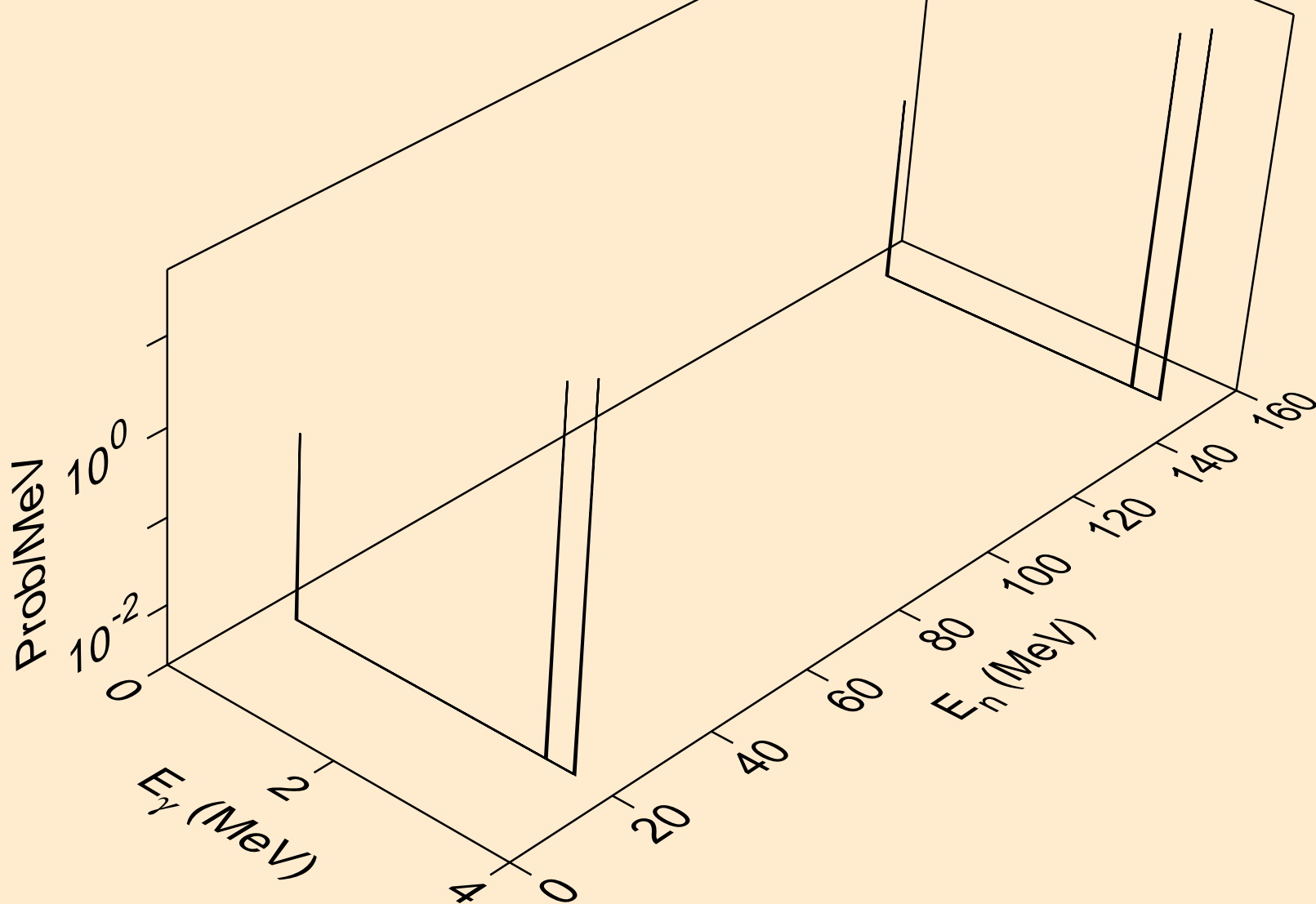

23-V-51 FOR FENDL-3.1 FROM FENDL-3.1 WITH NJOY2012.50+ C
Photon emission for (n,n*31)

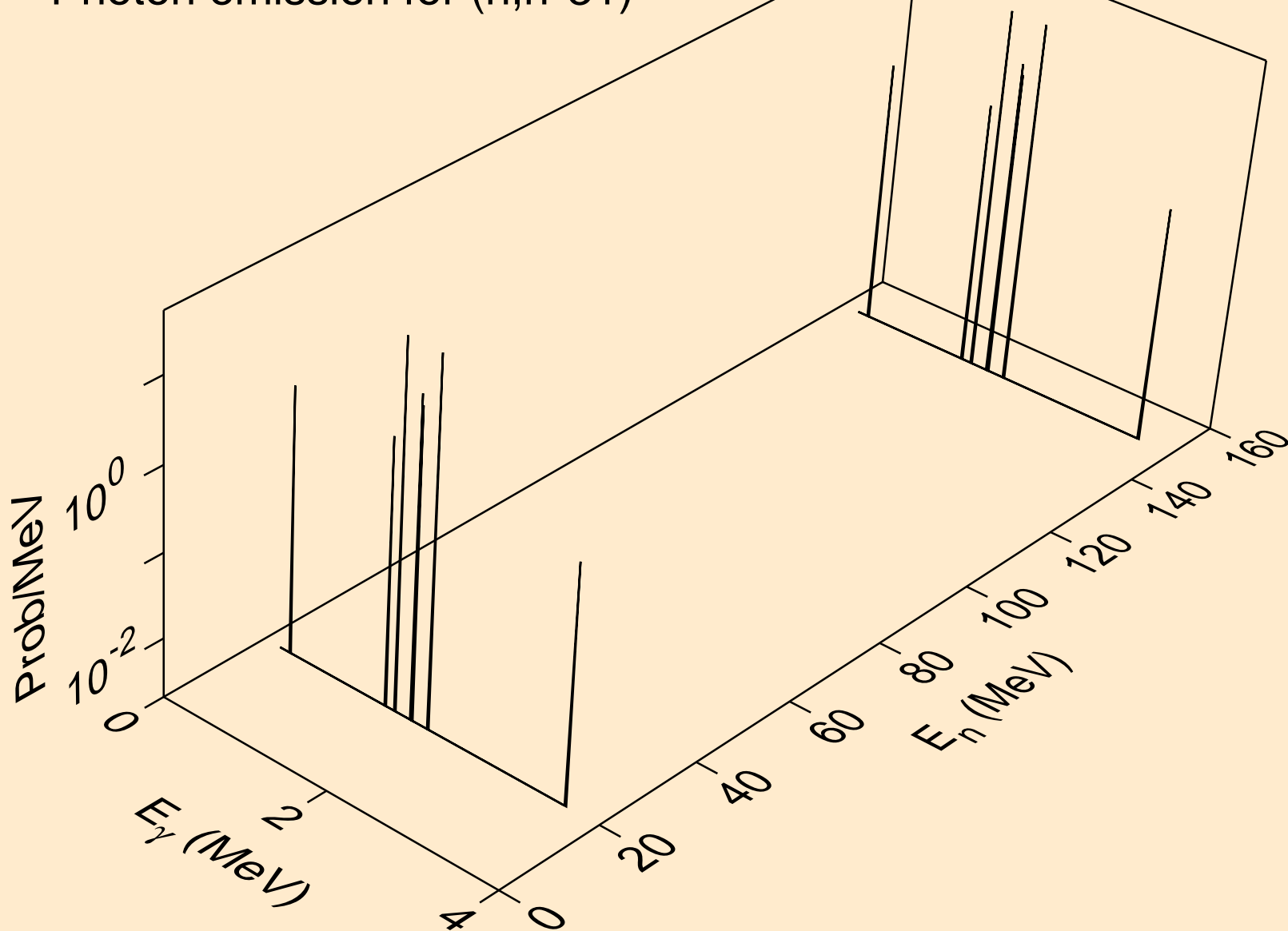

23-V-51 FOR FENDL-3.1 FROM FENDL-3.1 WITH NJOY2012.50+ C
Photon emission for (n,n*32)

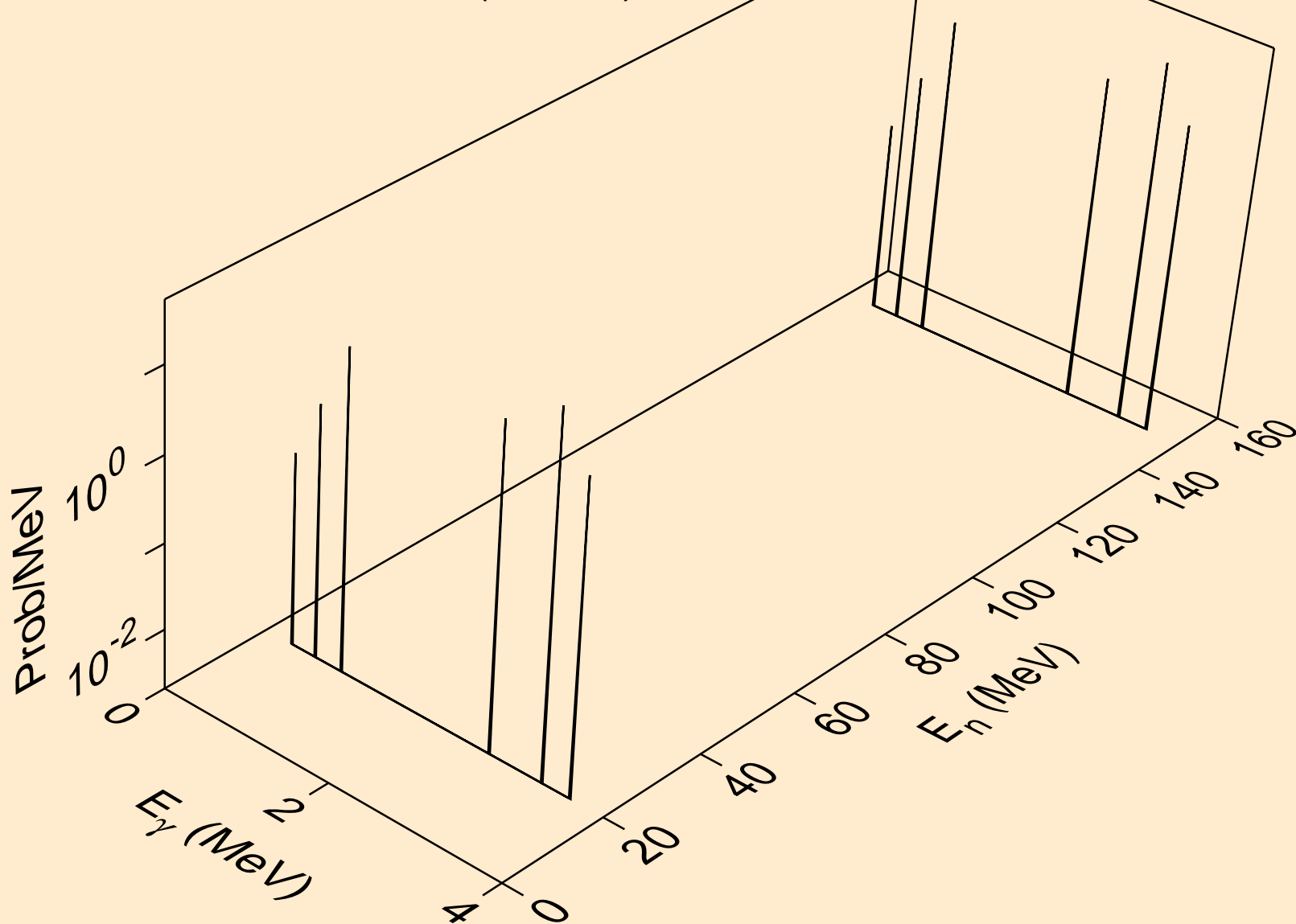

23-V-51 FOR FENDL-3.1 FROM FENDL-3.1 WITH NJOY2012.50+ C
Photon emission for (n,n*33)

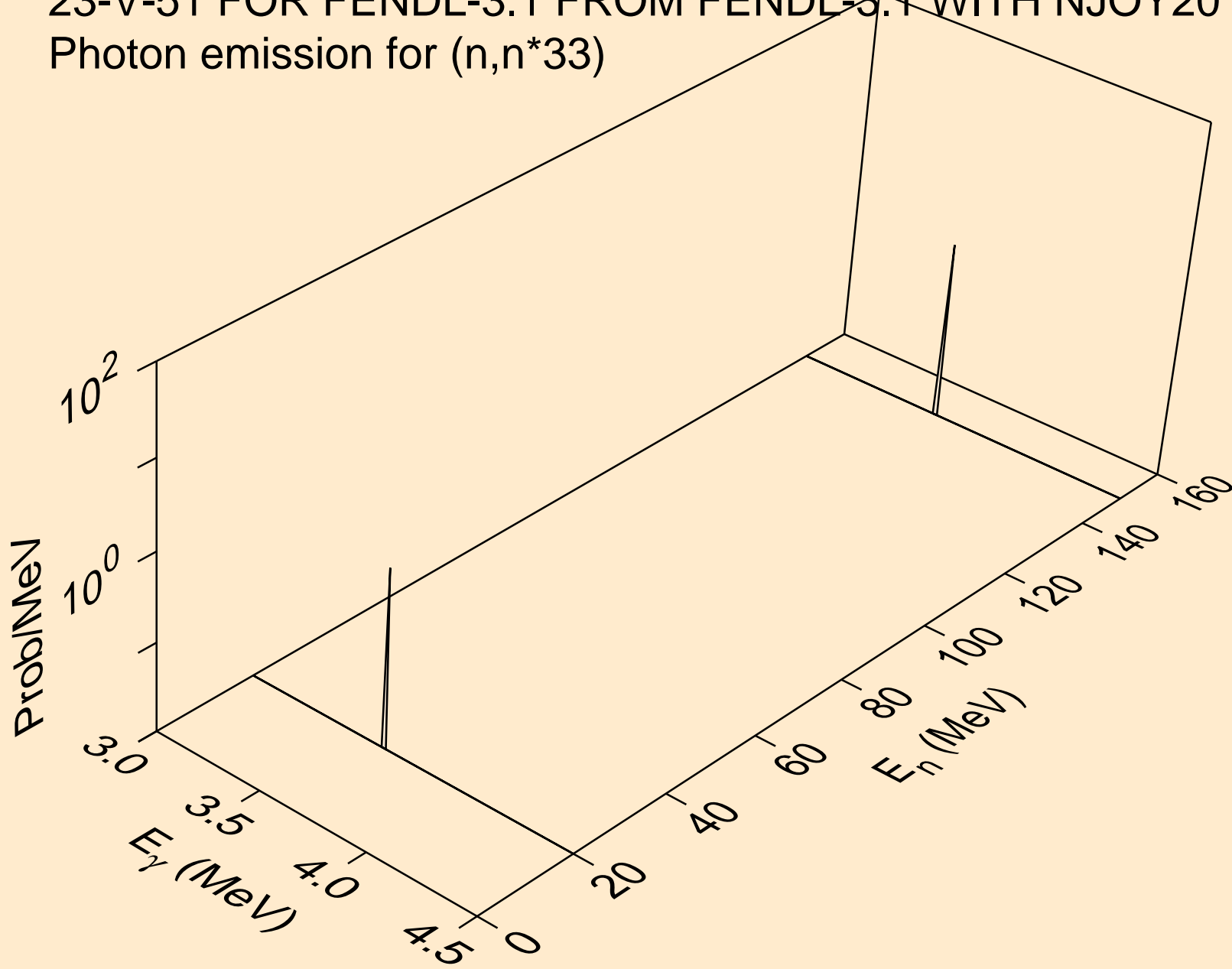

23-V-51 FOR FENDL-3.1 FROM FENDL-3.1 WITH NJOY2012.50+ C
Photon emission for (n,n*34)

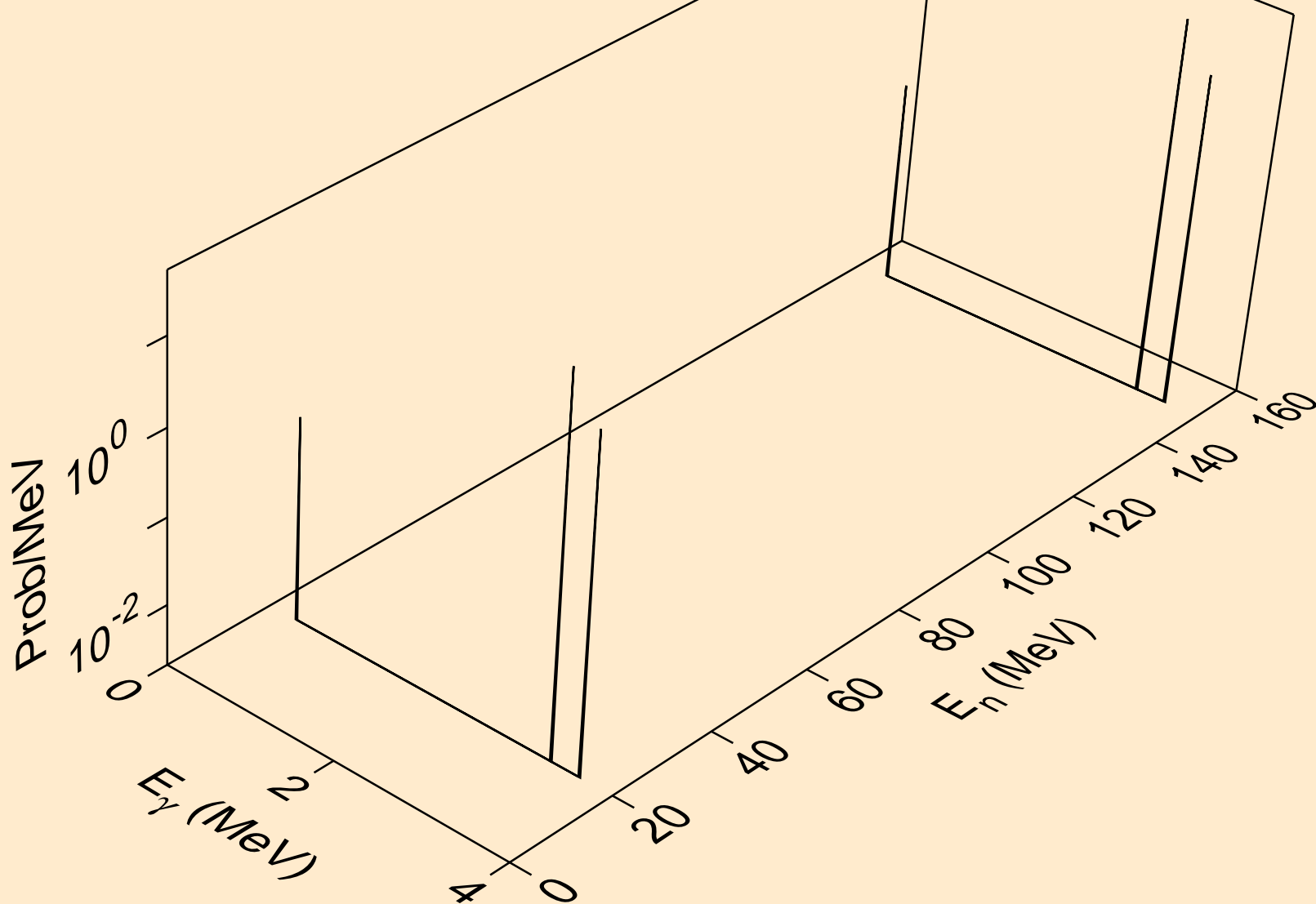

23-V-51 FOR FENDL-3.1 FROM FENDL-3.1 WITH NJOY2012.50+ C
Photon emission for (n,n*35)

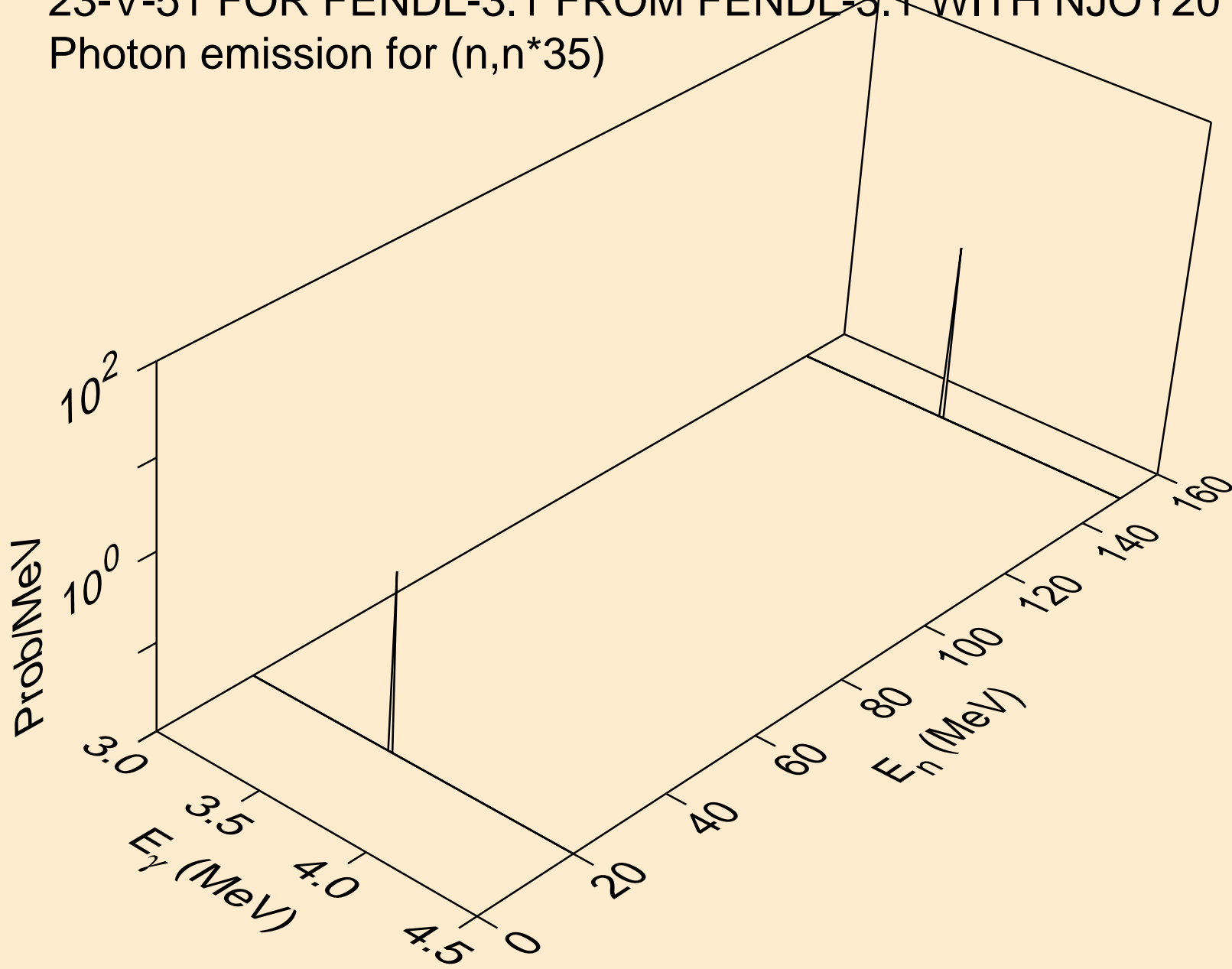

23-V-51 FOR FENDL-3.1 FROM FENDL-3.1 WITH NJOY2012.50+ C
Photon emission for (n,n*36)

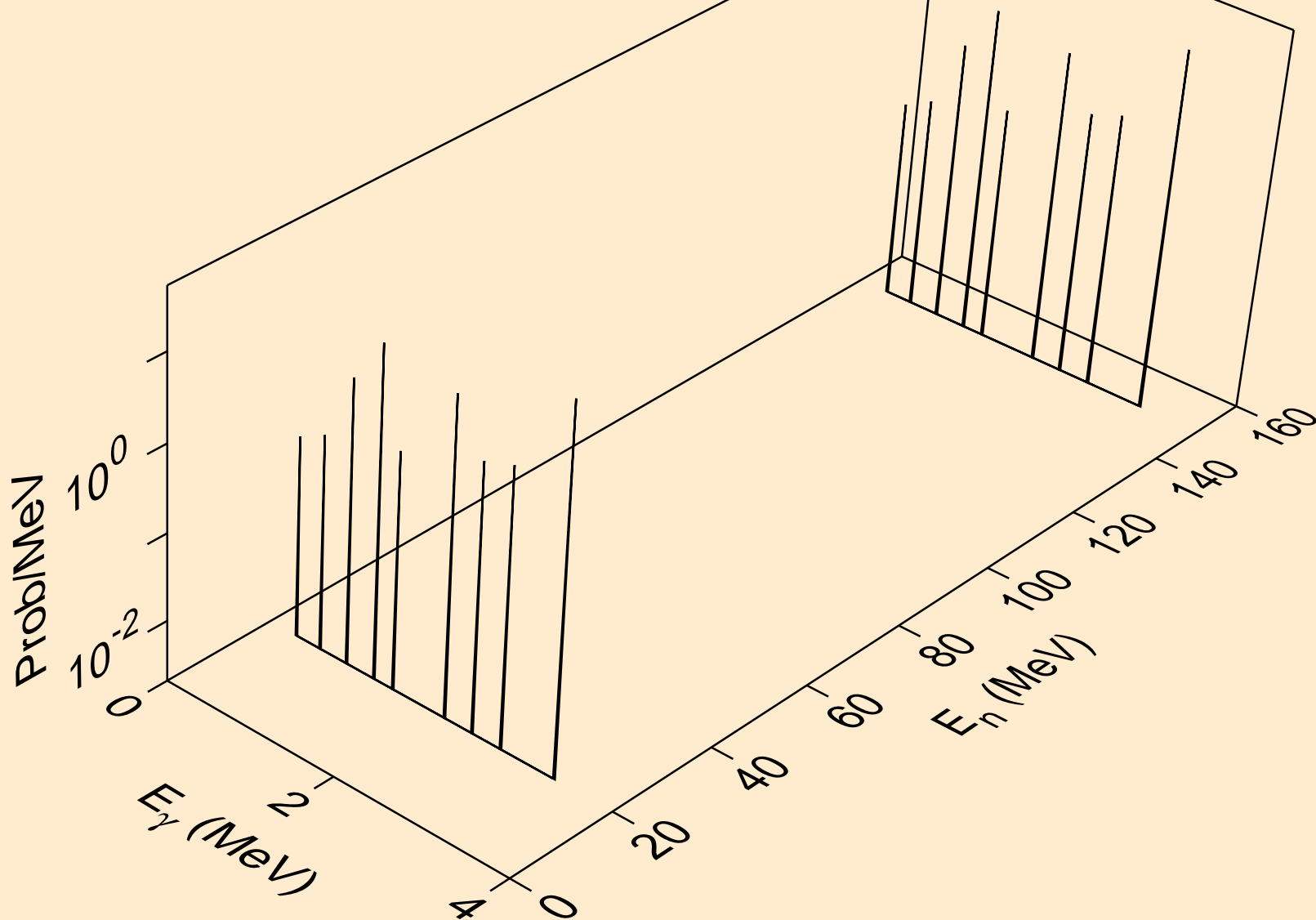

23-V-51 FOR FENDL-3.1 FROM FENDL-3.1 WITH NJOY2012.50+ C
Photon emission for (n,n*37)

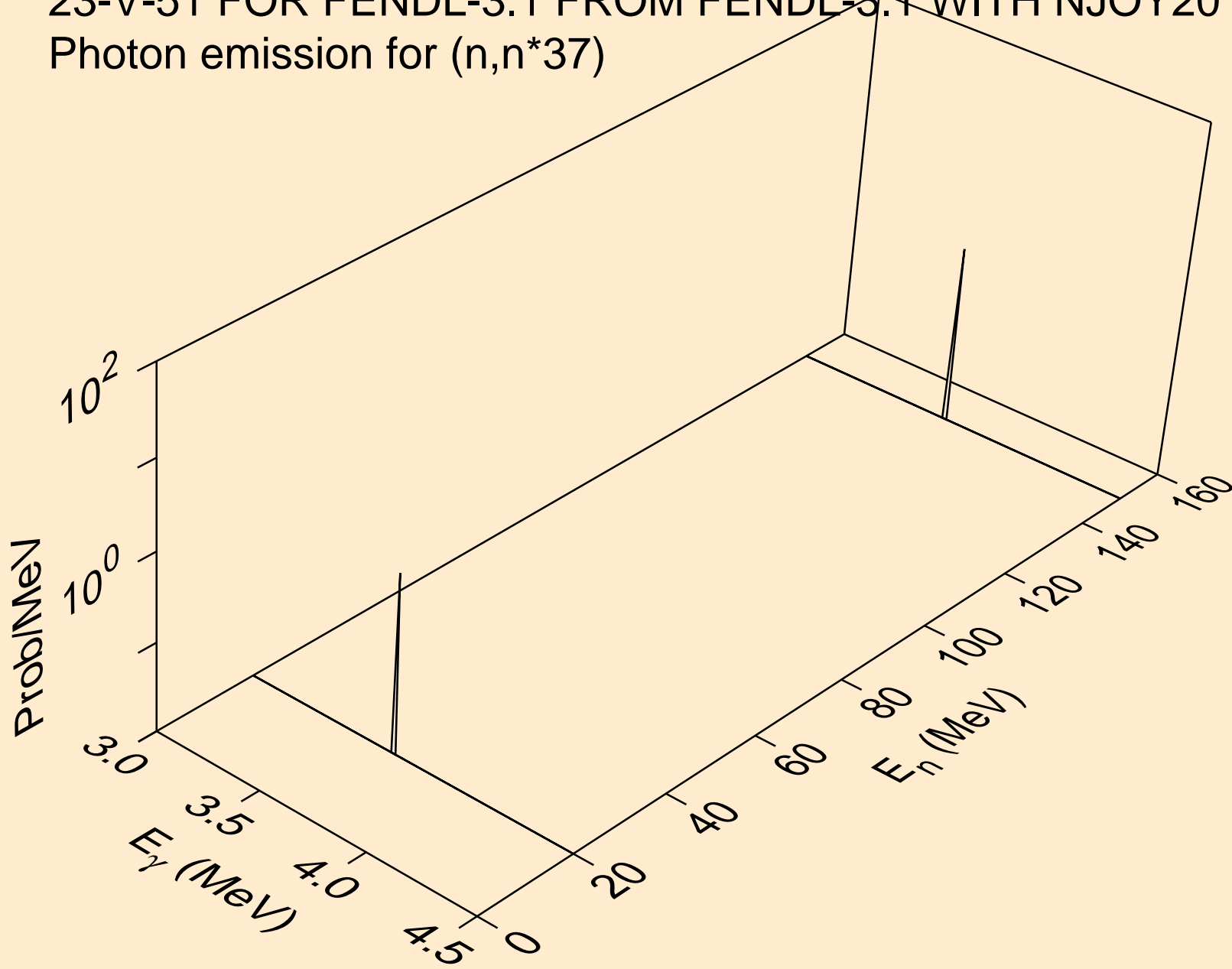

23-V-51 FOR FENDL-3.1 FROM FENDL-3.1 WITH NJOY2012.50+ C
Photon emission for (n,n*38)

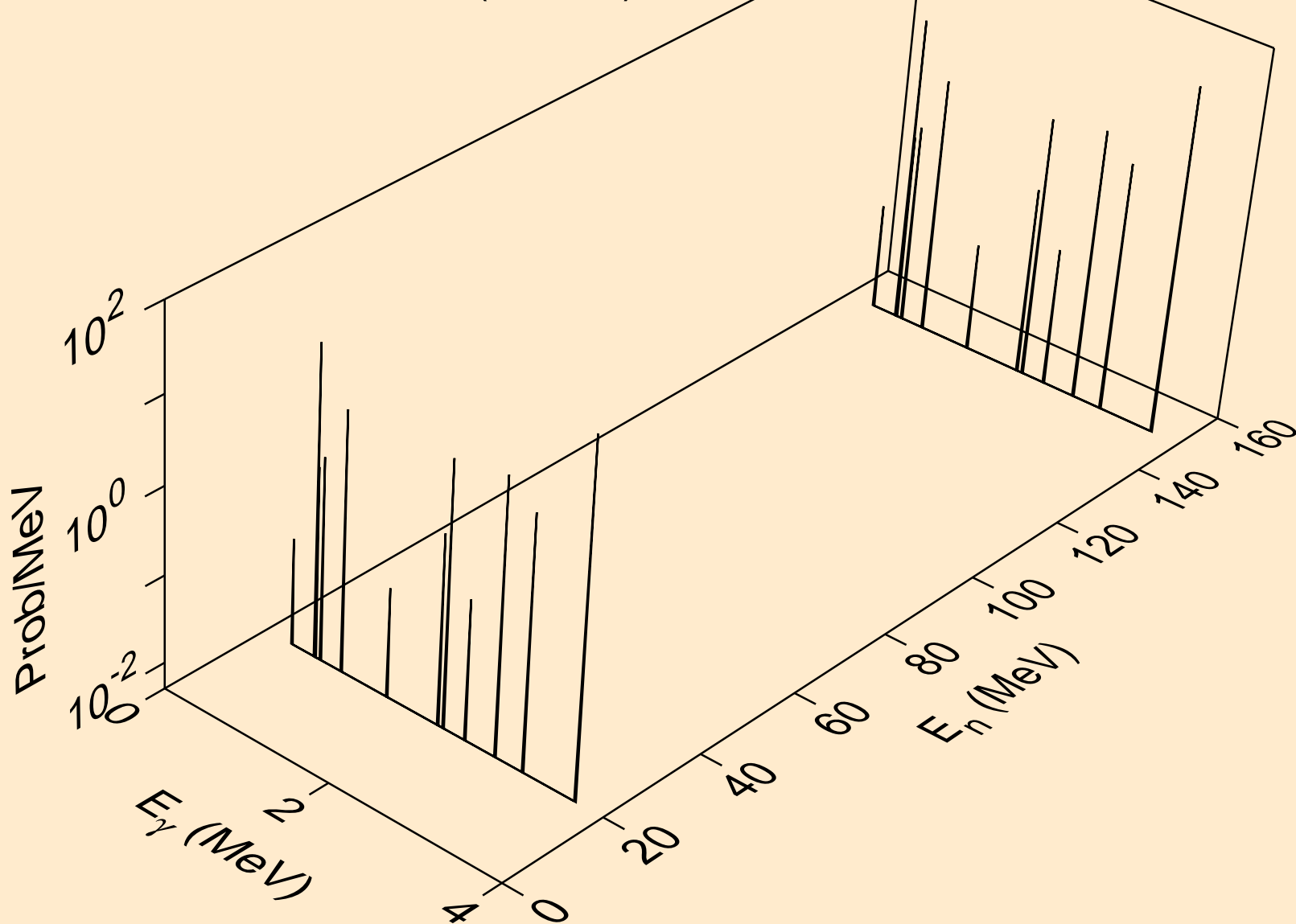

23-V-51 FOR FENDL-3.1 FROM FENDL-3.1 WITH NJOY2012.50+ C
Photon emission for (n,n*39)

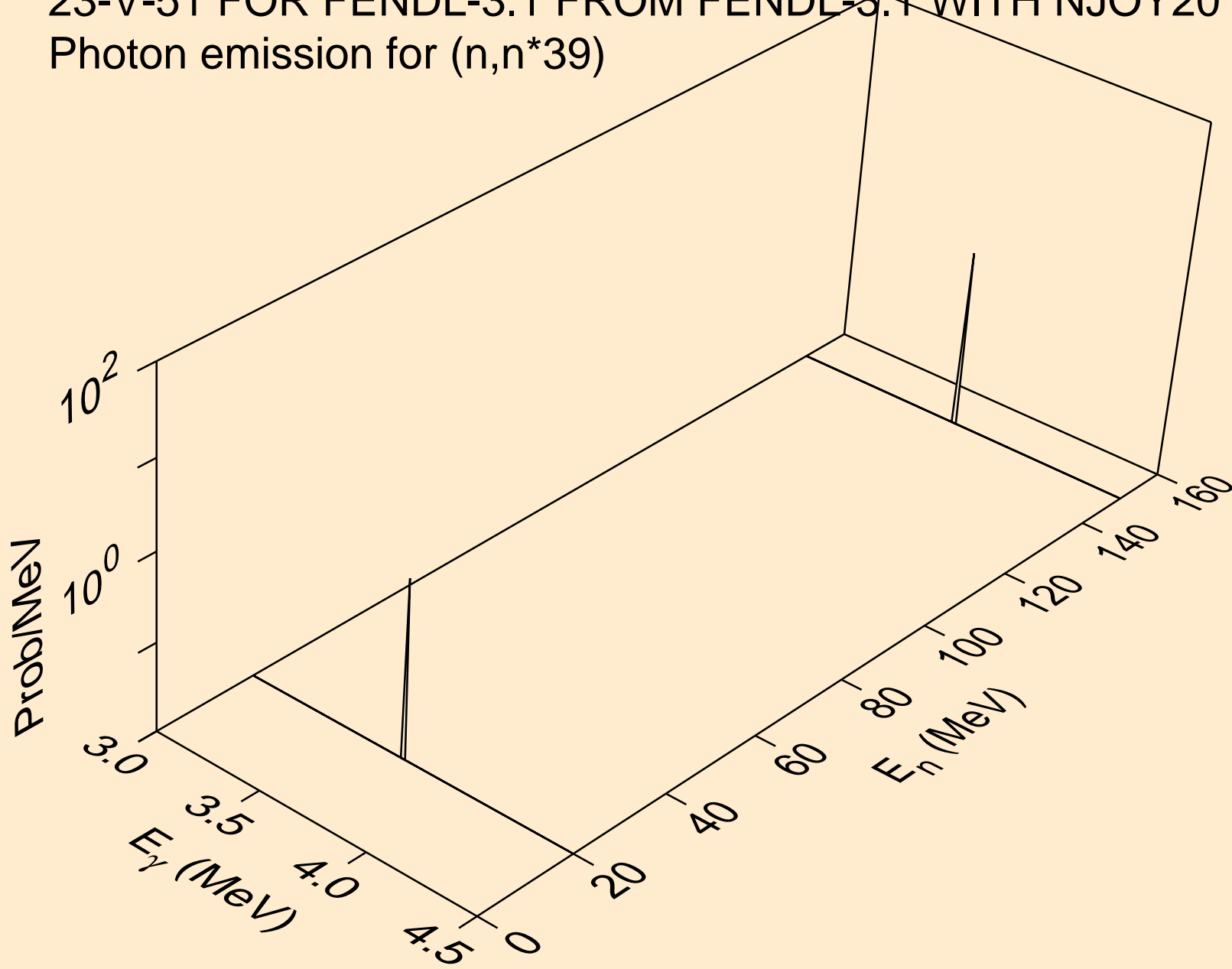

23-V-51 FOR FENDL-3.1 FROM FENDL-3.1 WITH NJOY2012.50+ C
Photon emission for (n,n*40)

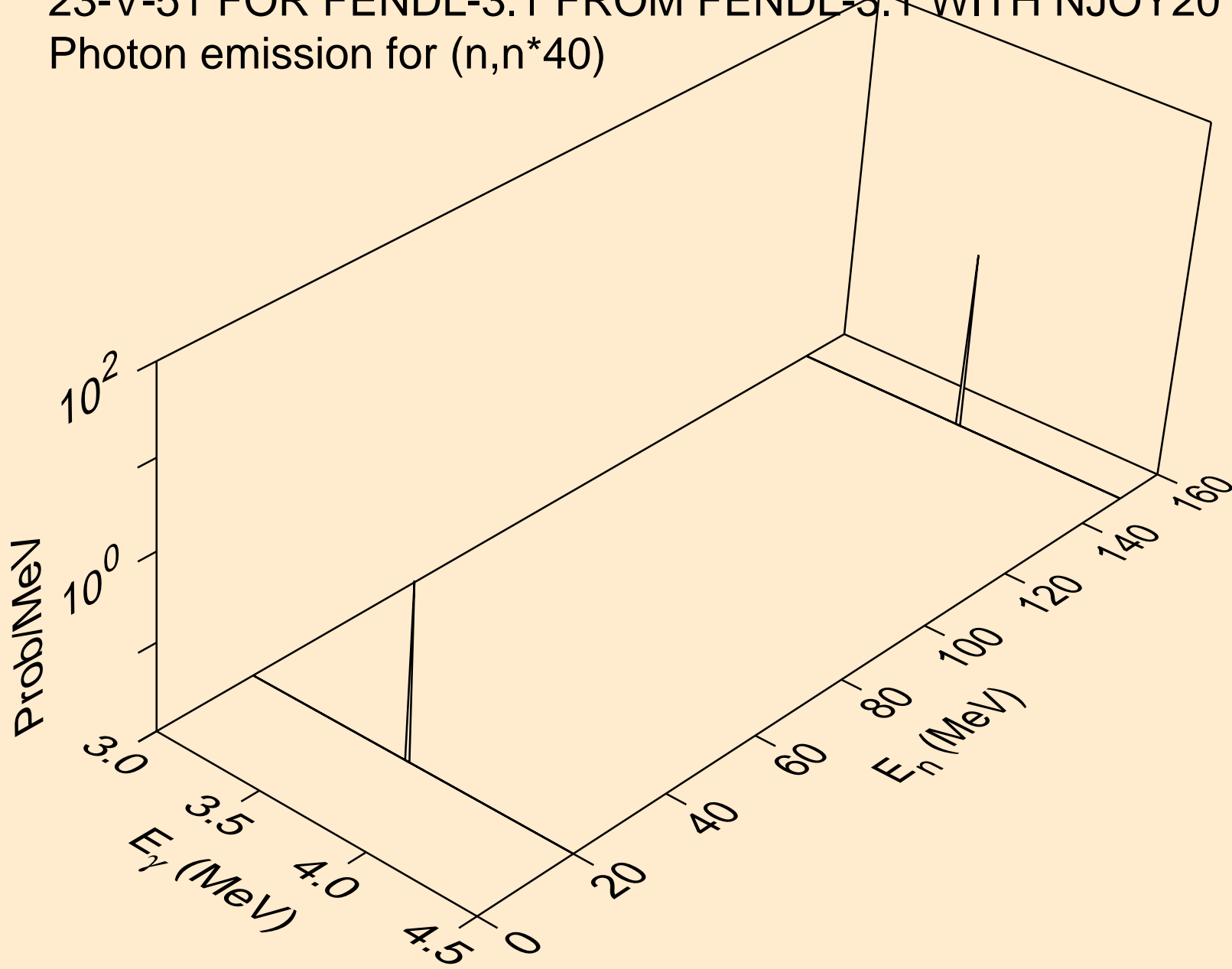

23-V-51 FOR FENDL-3.1 FROM FENDL-3.1 WITH NJOY2012.50+ C
Photon emission for (n,n*c)

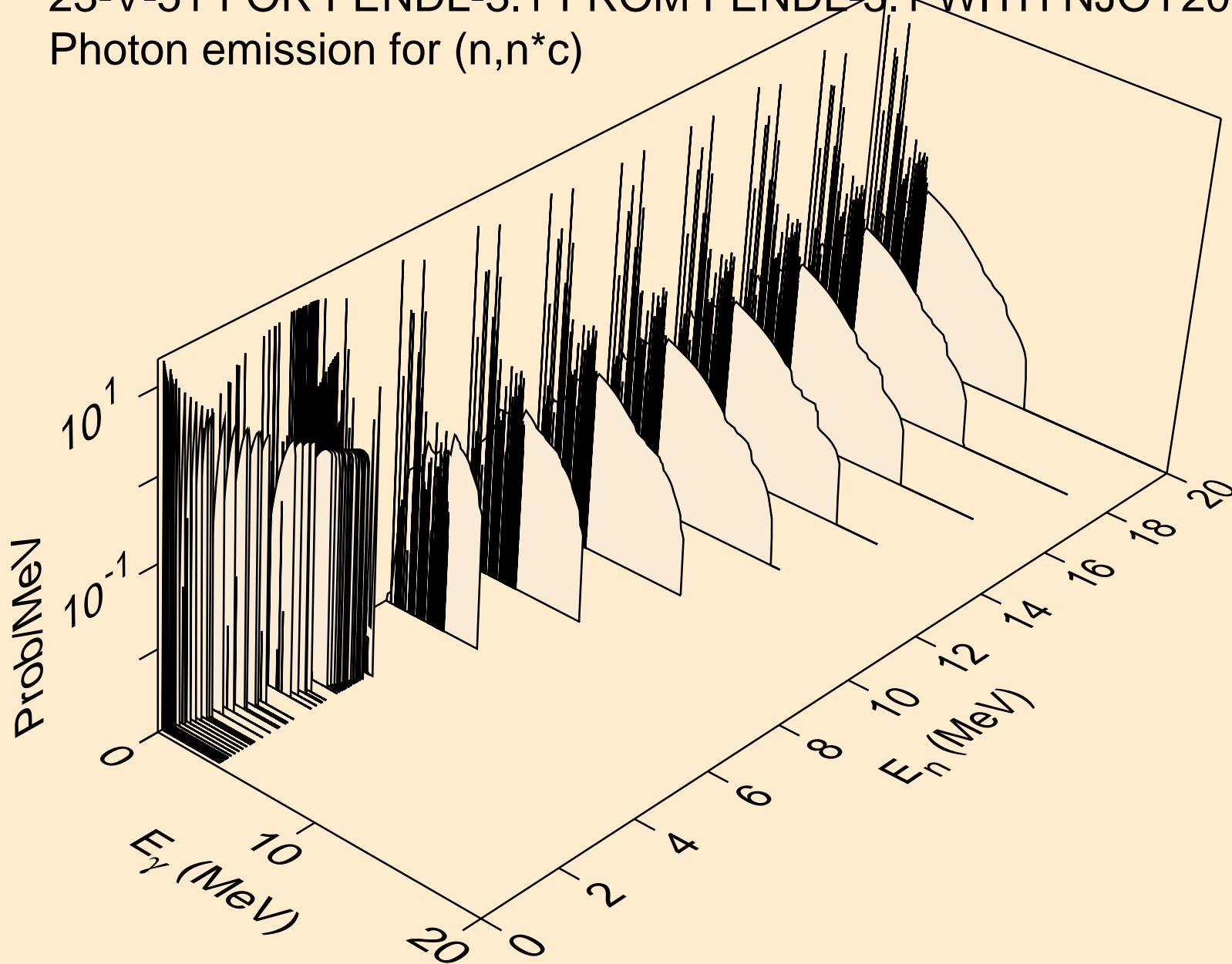

23-V-51 FOR FENDL-3.1 FROM FENDL-3.1 WITH NJOY2012.50+ C
Photon emission for (n,gma)

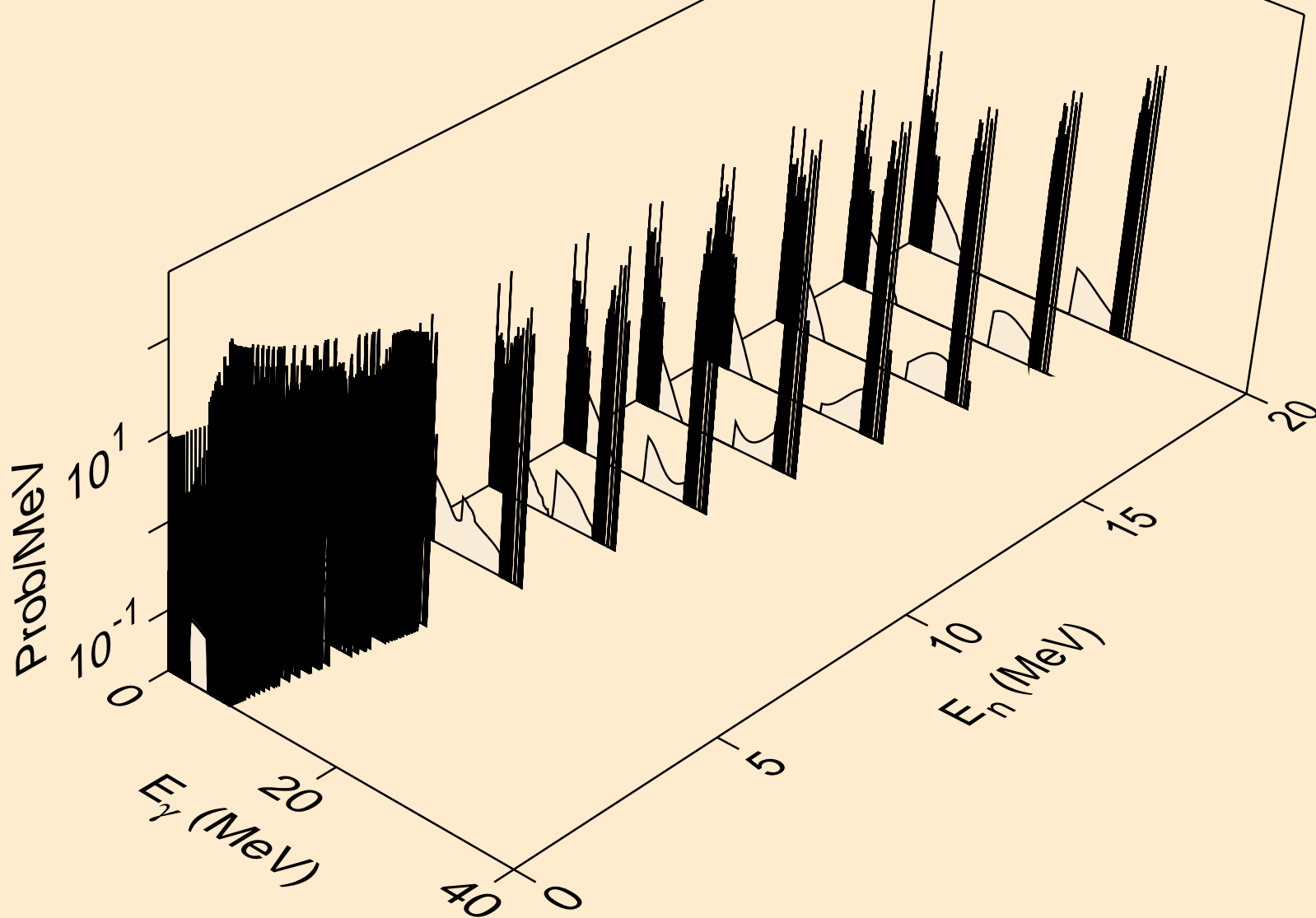

23-V-51 FOR FENDL-3.1 FROM FENDL-3.1 WITH NJOY2012.50+ C
thermal capture photon spectrum

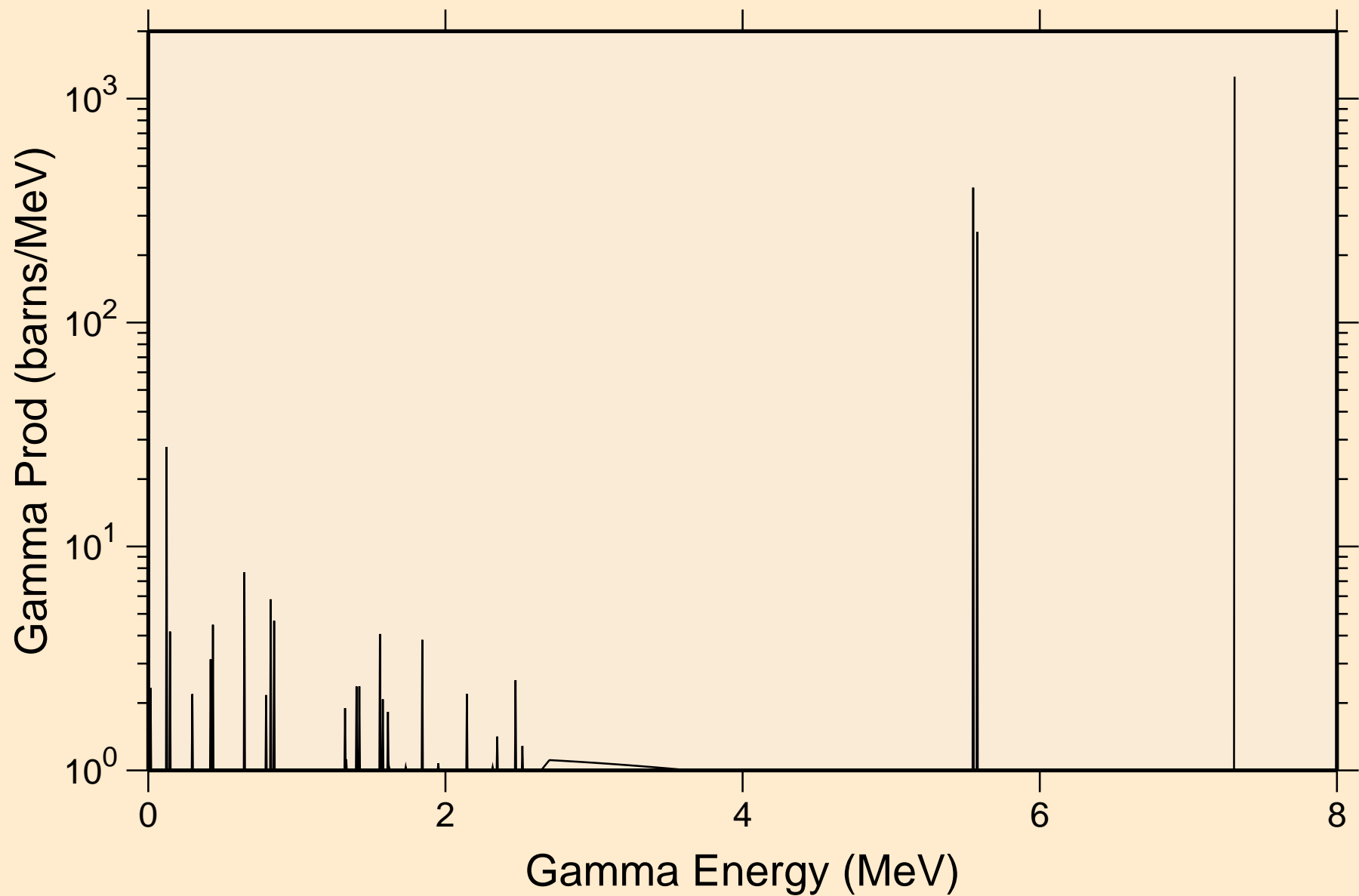

23-V-51 FOR FENDL-3.1 FROM FENDL-3.1 WITH NJOY2012.50+ C
14 MeV photon spectrum

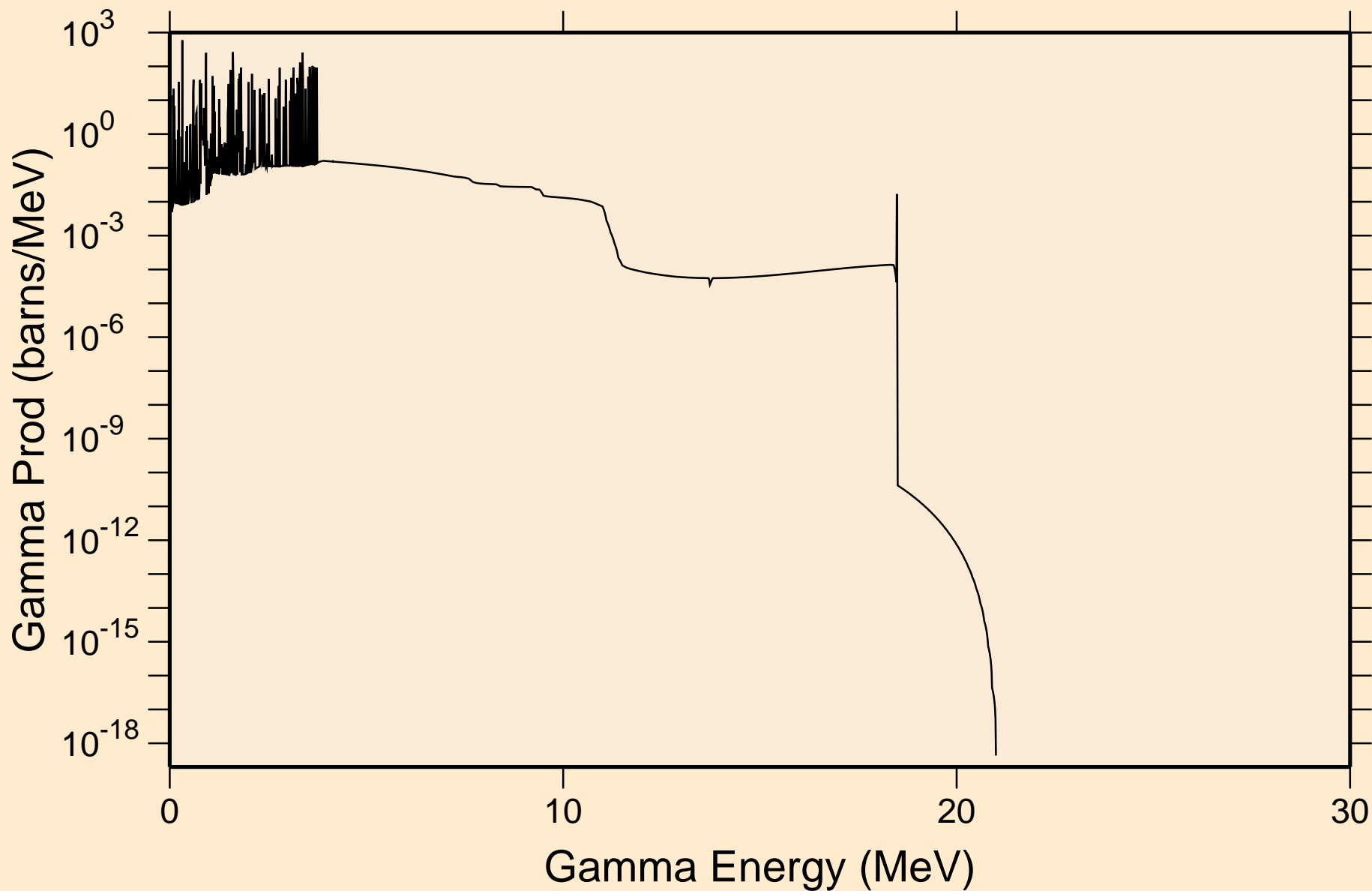

23-V-51 FOR FENDL-3.1 FROM FENDL-3.1 WITH NJOY2012.50+ C

Particle heating contributions

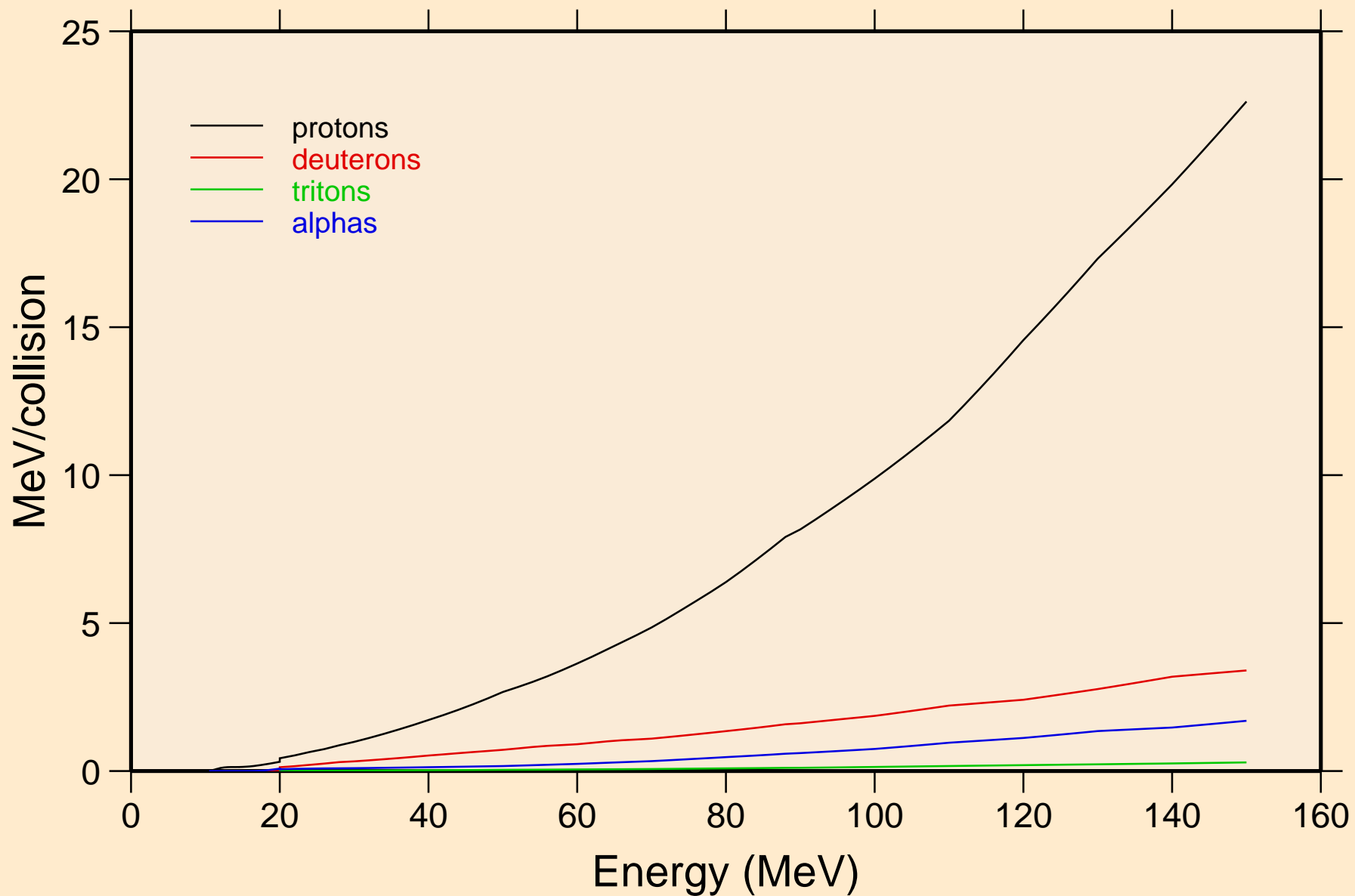

23-V-51 FOR FENDL-3.1 FROM FENDL-3.1 WITH NJOY2012.50+ C Recoil Heating

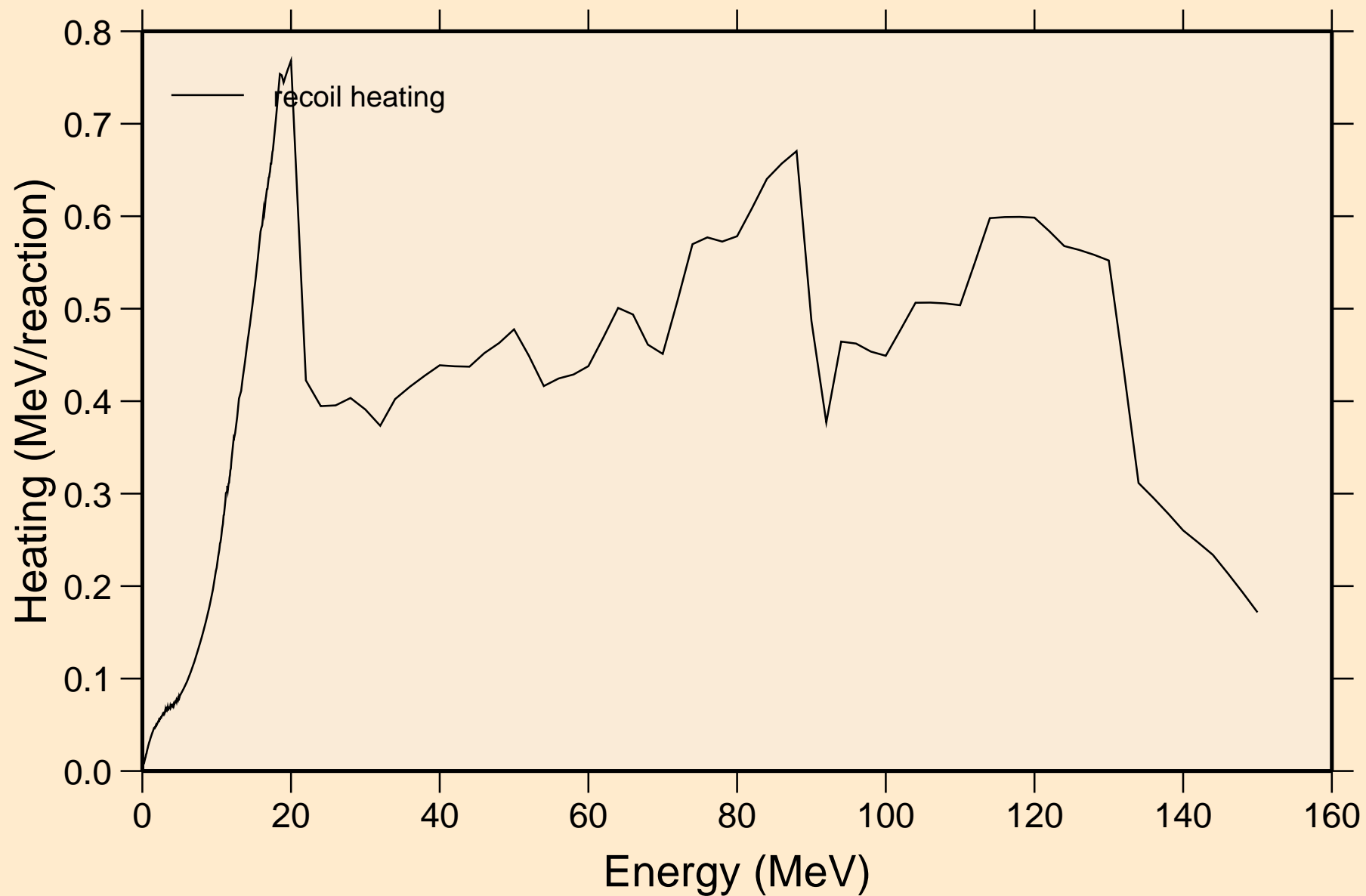

23-V-51 FOR FENDL-3.1 FROM FENDL-3.1 WITH NJOY2012.50+ C
Particle production cross sections

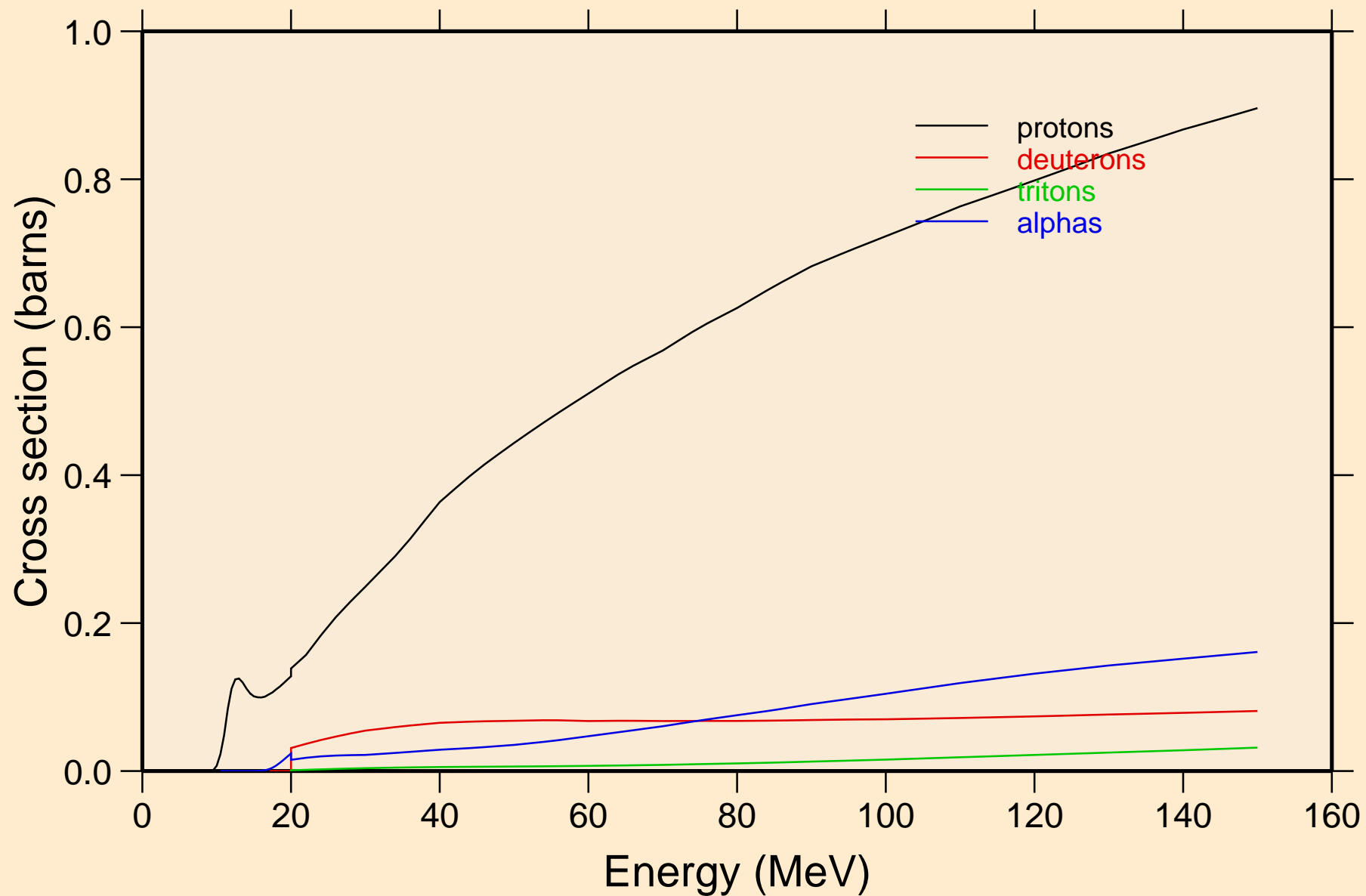

23-V-51 FOR FENDL-3.1 FROM FENDL-3.1 WITH NJOY2012.50+ C
protons from (n,x)

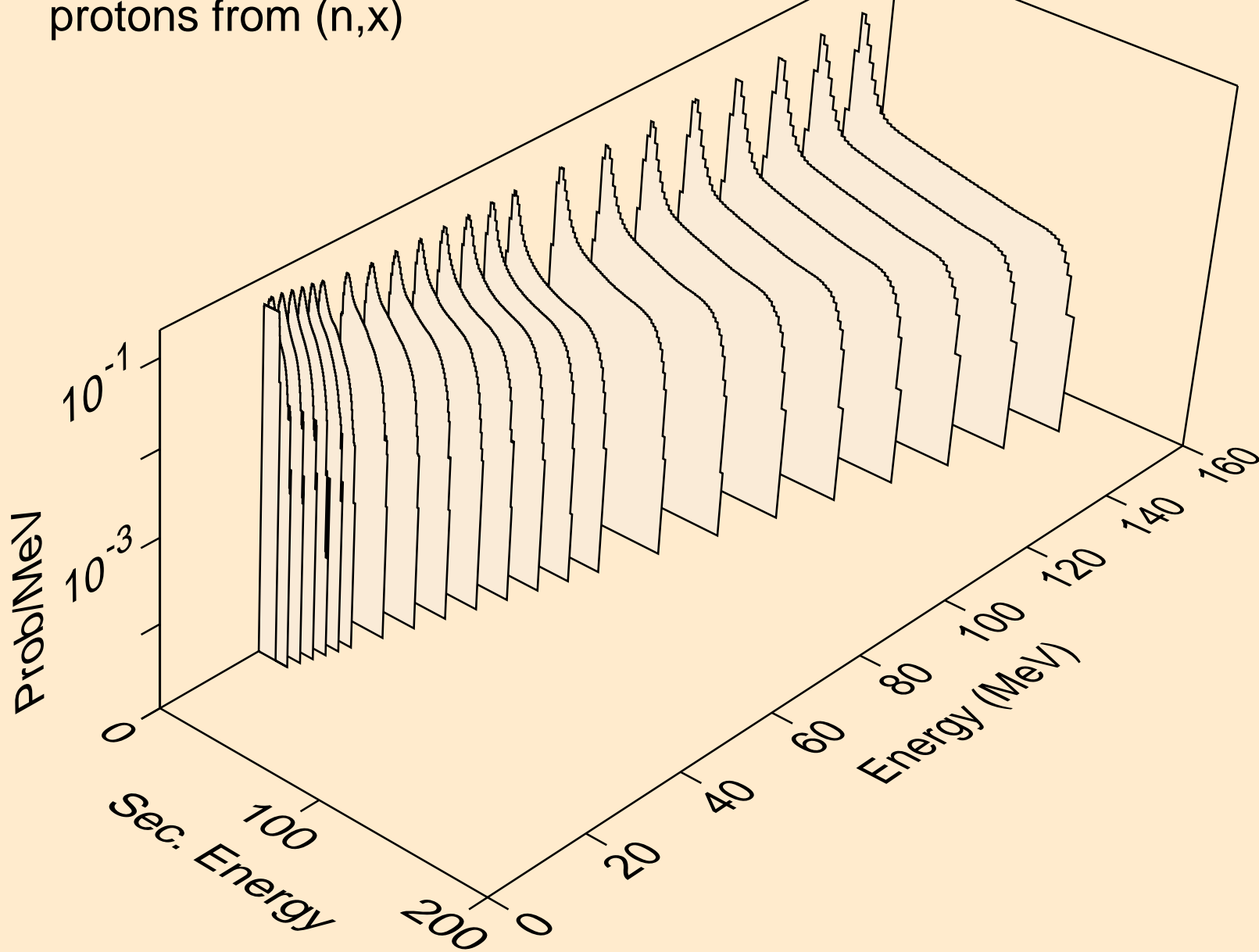

23-V-51 FOR FENDL-3.1 FROM FENDL-3.1 WITH NJOY2012.50+ C
protons from (n,n*)p

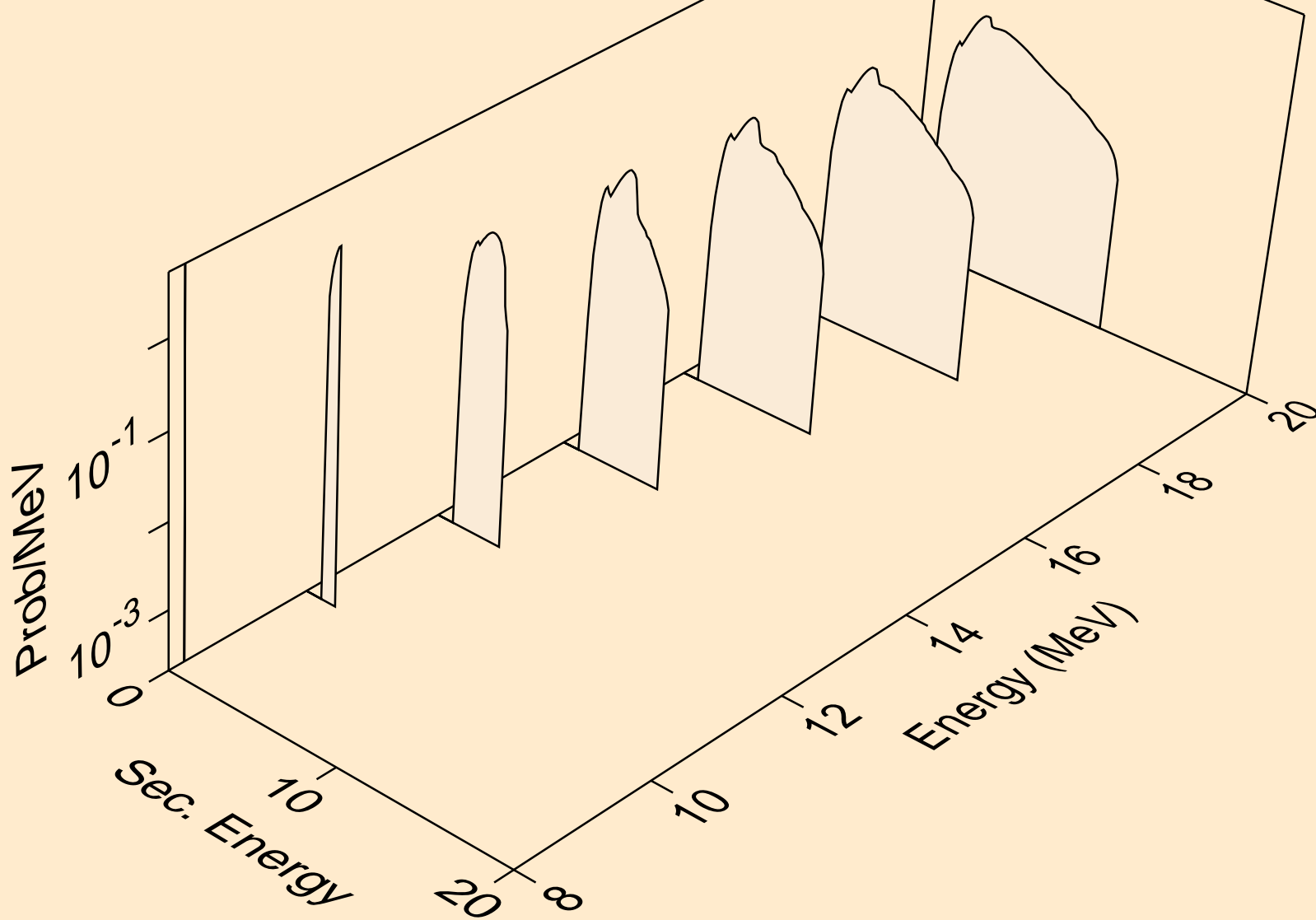

23-V-51 FOR FENDL-3.1 FROM FENDL-3.1 WITH NJOY2012.50+ C
deuterons from (n,x)

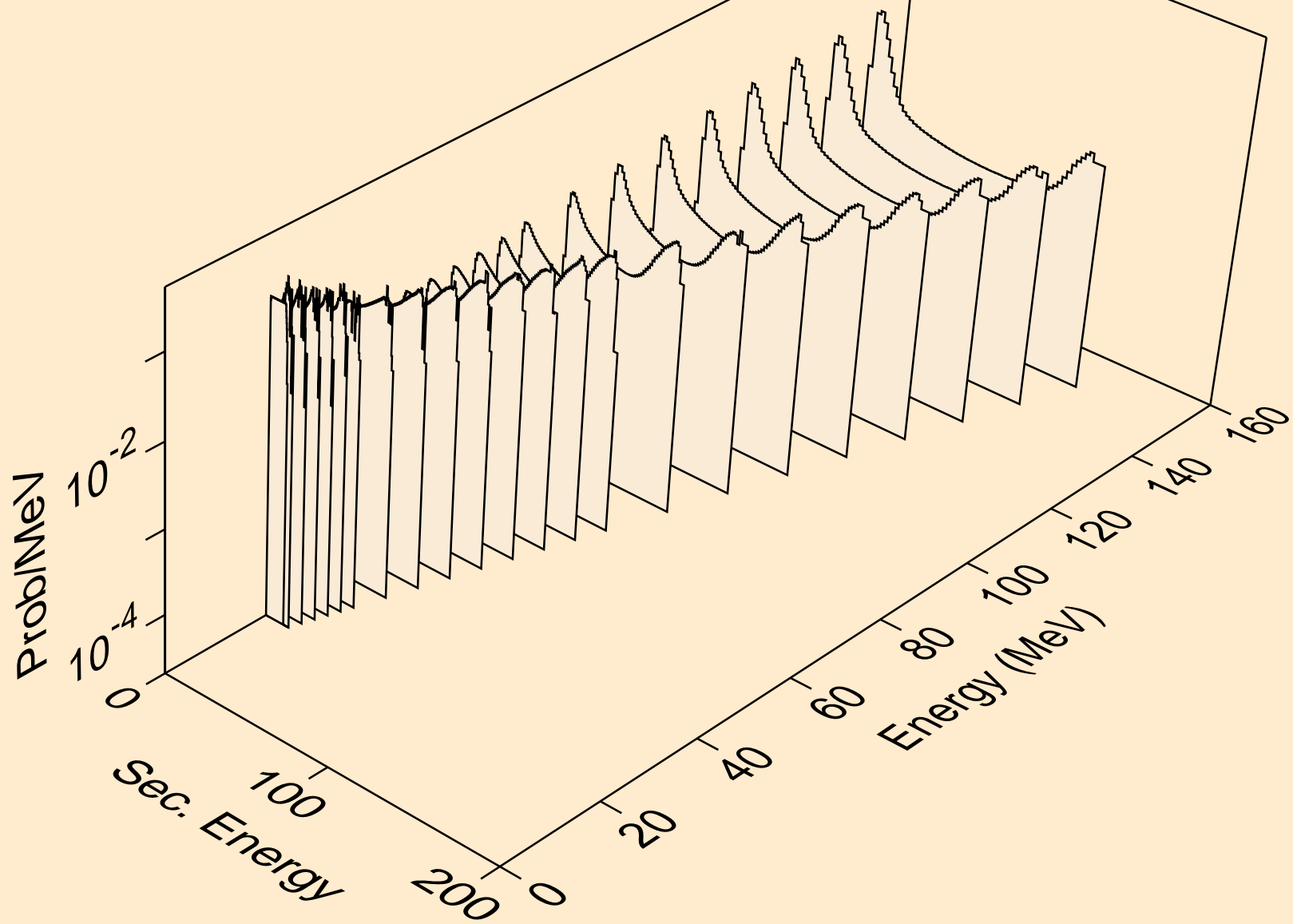

23-V-51 FOR FENDL-3.1 FROM FENDL-3.1 WITH NJOY2012.50+ C
deuterons from (n,n*)d

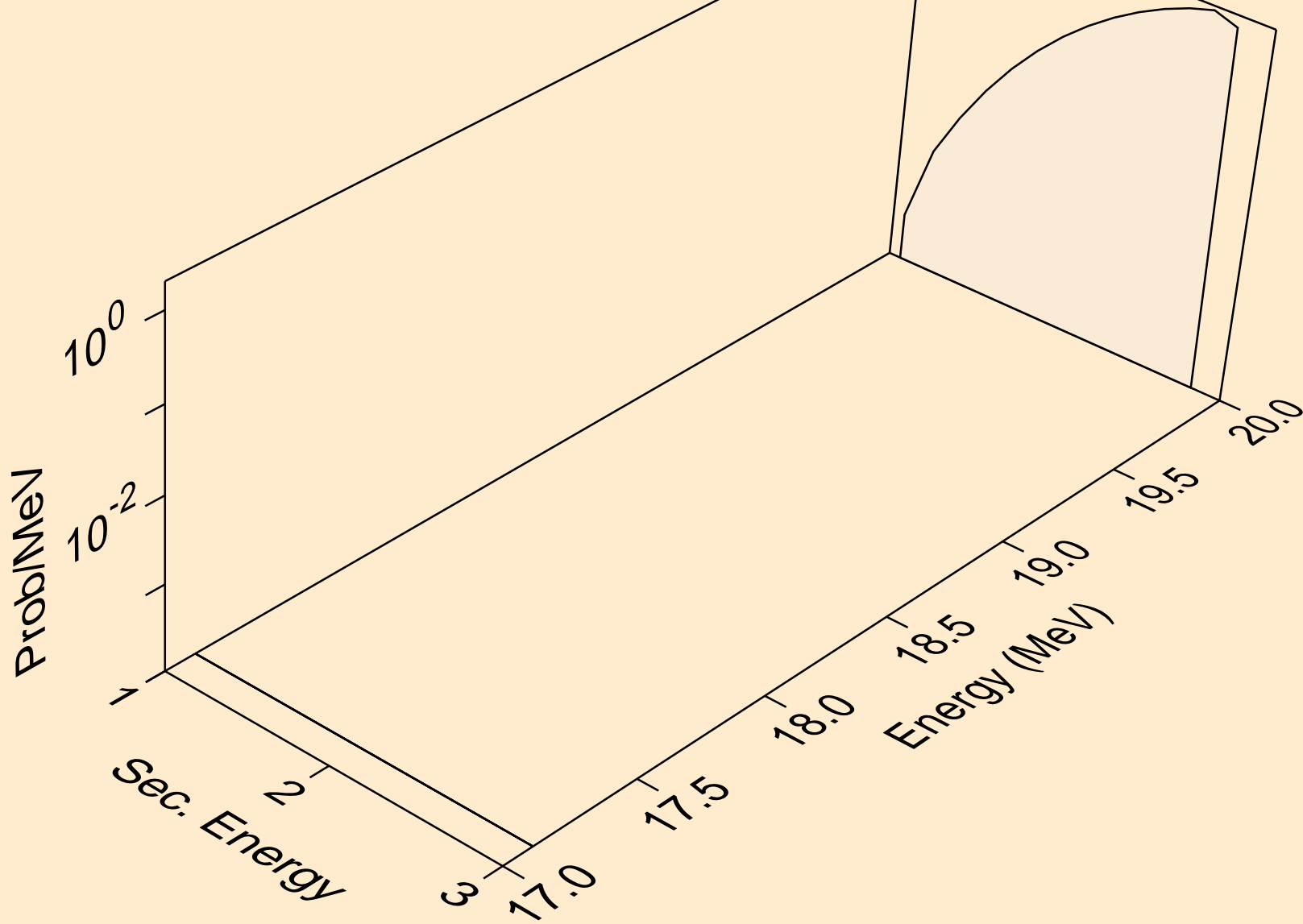

23-V-51 FOR FENDL-3.1 FROM FENDL-3.1 WITH NJOY2012.50+ C
tritons from (n,x)

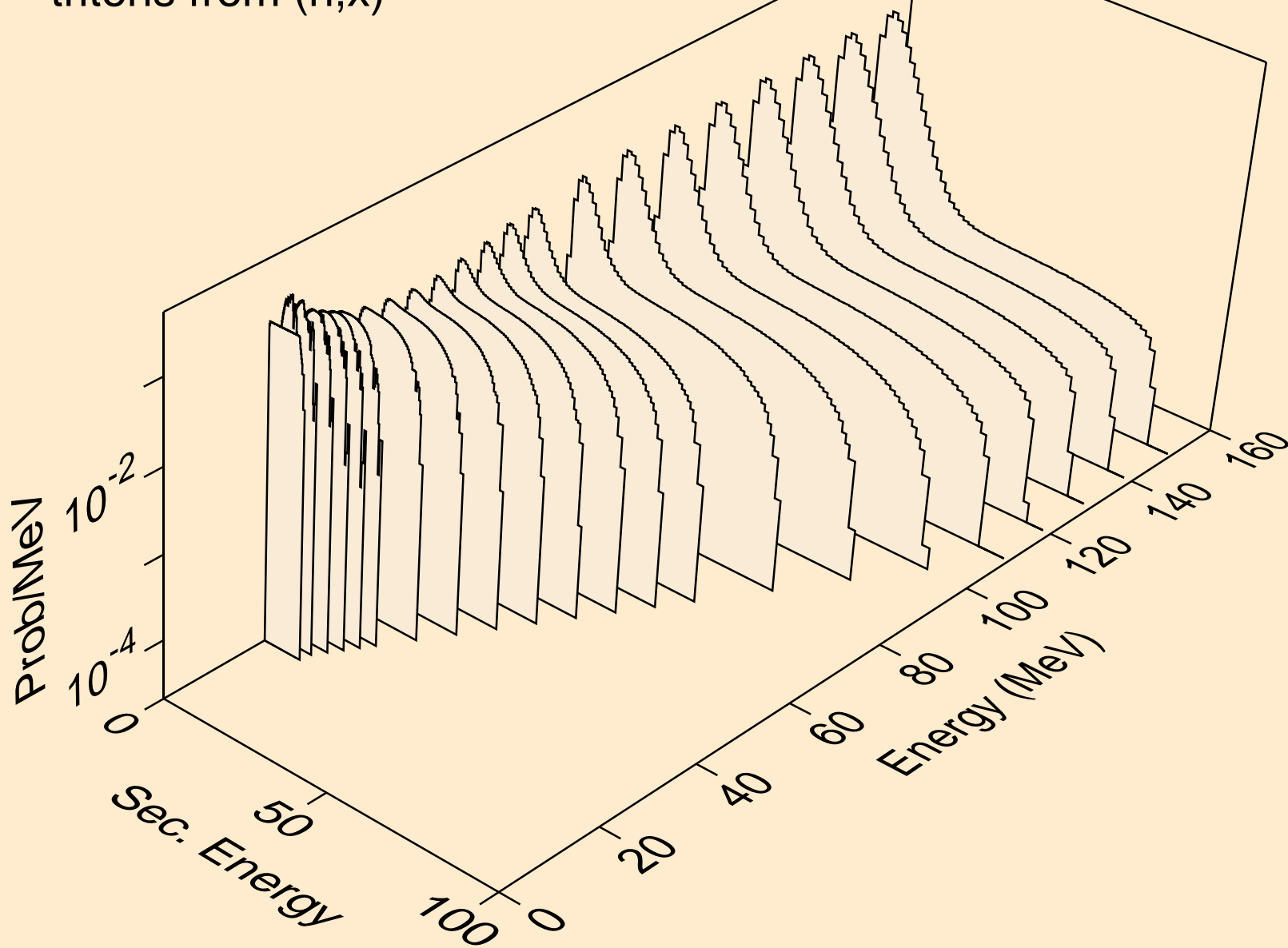

23-V-51 FOR FENDL-3.1 FROM FENDL-3.1 WITH NJOY2012.50+ C
alphas from (n,x)

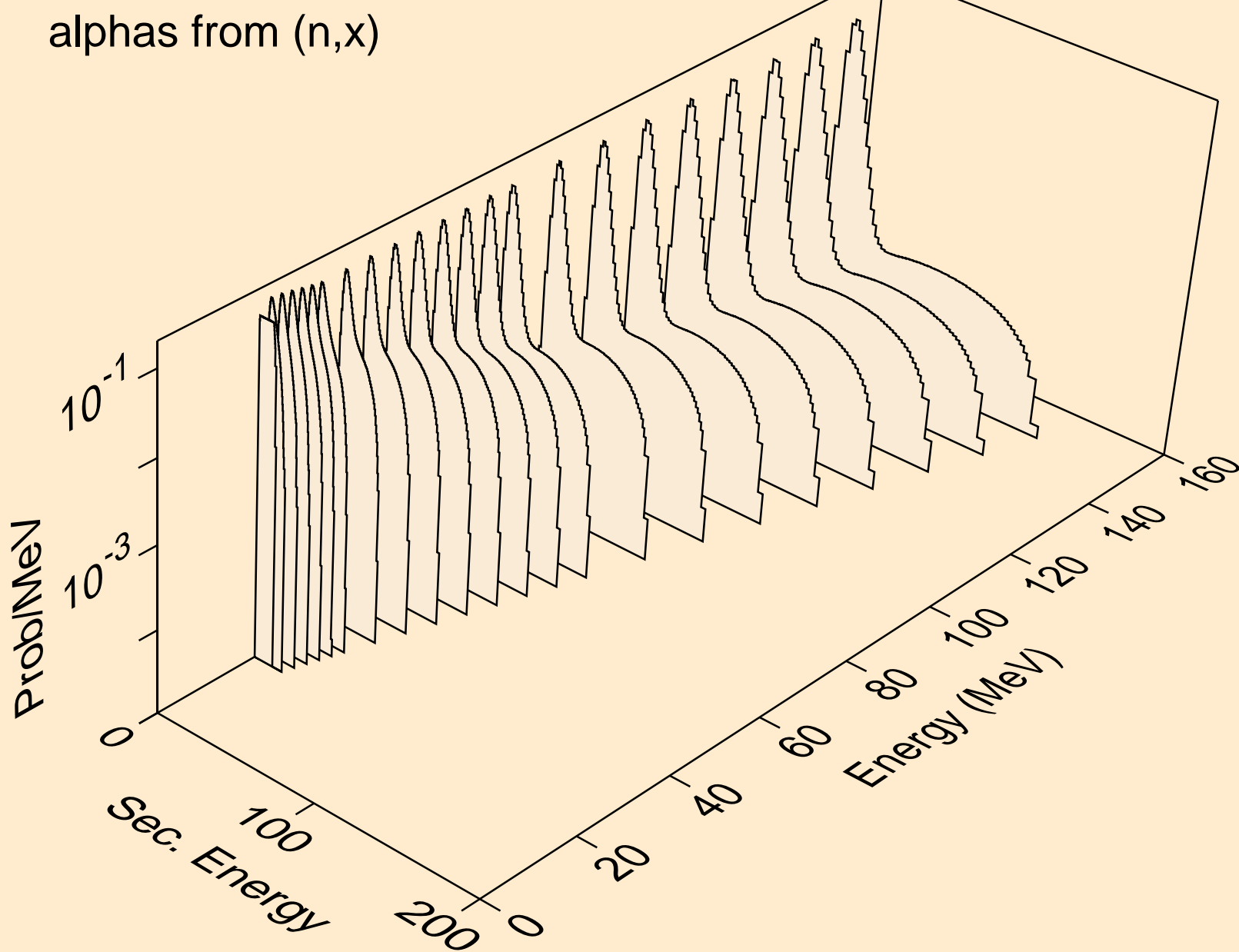

23-V-51 FOR FENDL-3.1 FROM FENDL-3.1 WITH NJOY2012.50+ C
alphas from (n,n*)a

