

24-CR-53 FOR FENDL-3.1 FROM KIT-2010 WITH NJOY2012.50+ C
Principal cross sections

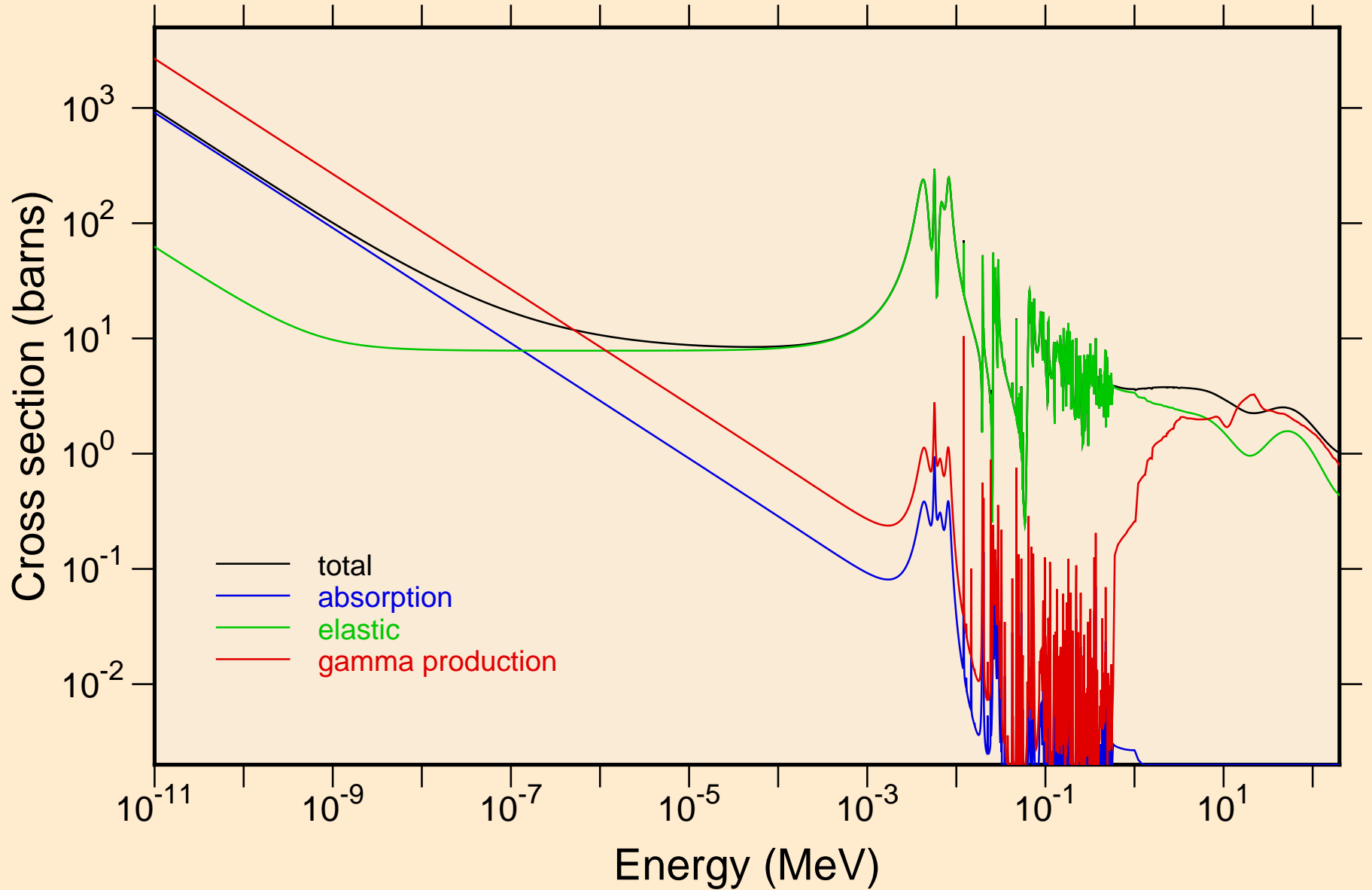

24-CR-53 FOR FENDL-3.1 FROM KIT-2010 WITH NJOY2012.50+ C
resonance total cross section

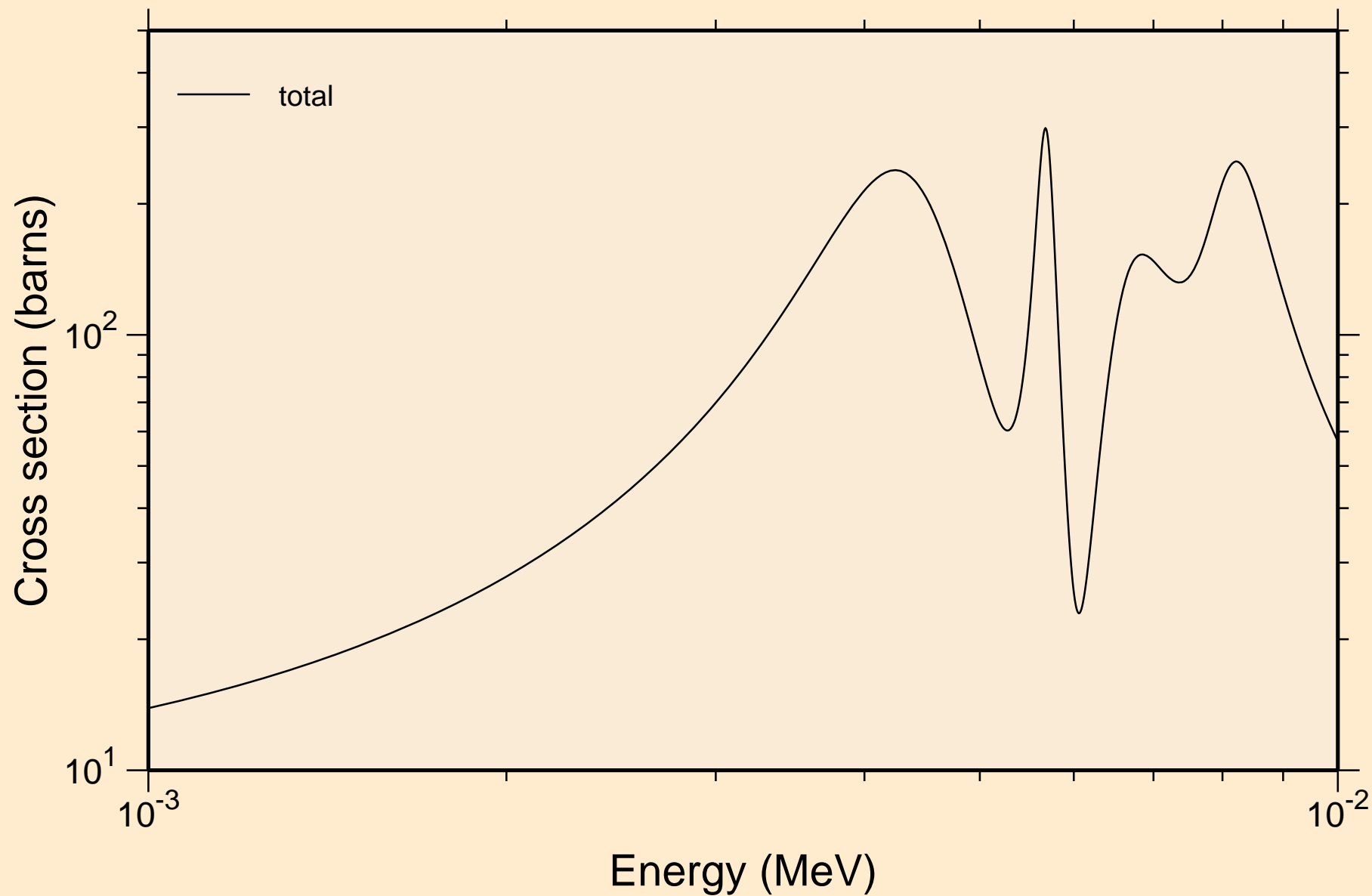

24-CR-53 FOR FENDL-3.1 FROM KIT-2010 WITH NJOY2012.50+ C
resonance total cross section

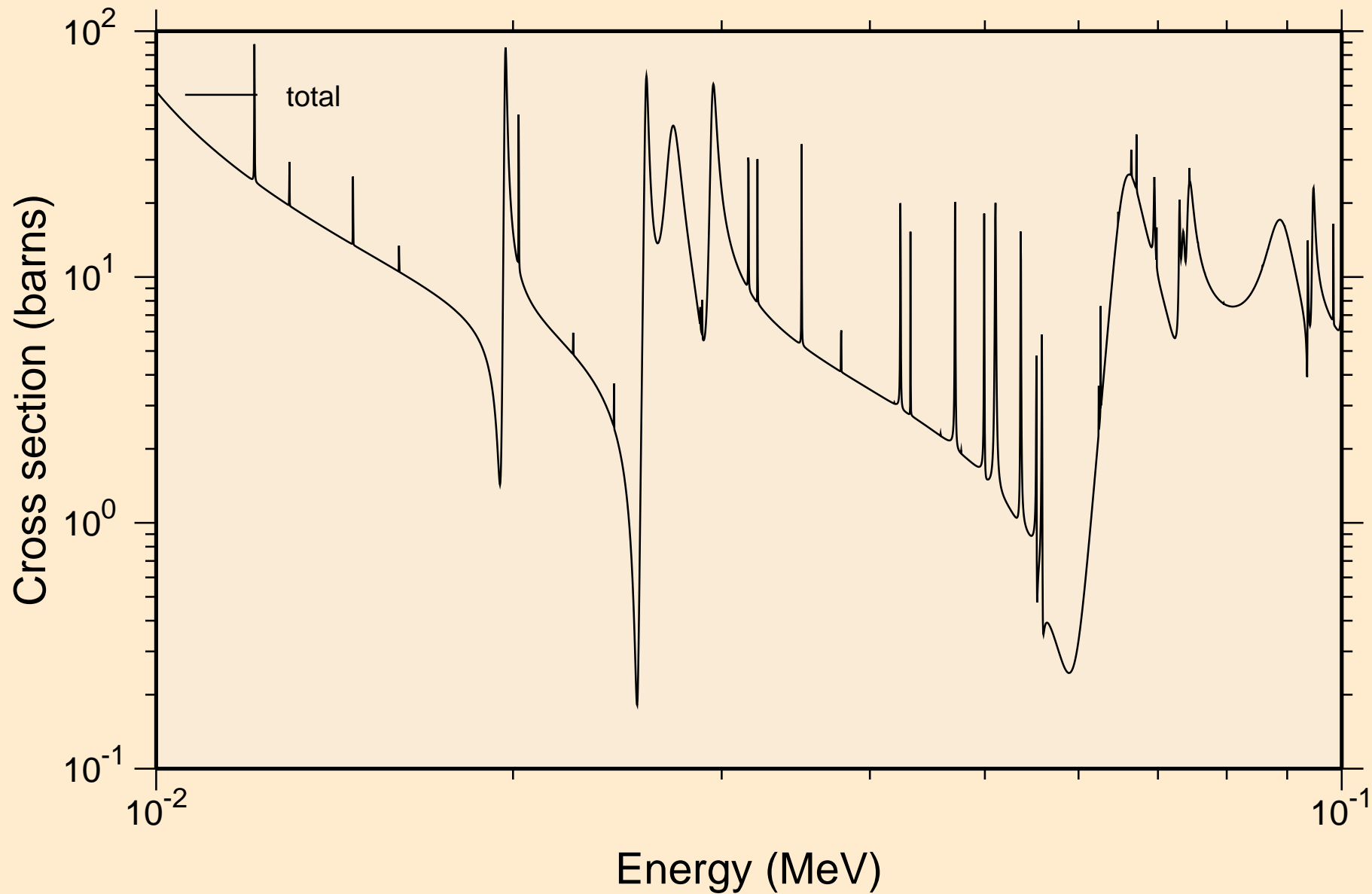

24-CR-53 FOR FENDL-3.1 FROM KIT-2010 WITH NJOY2012.50+ C
resonance total cross section

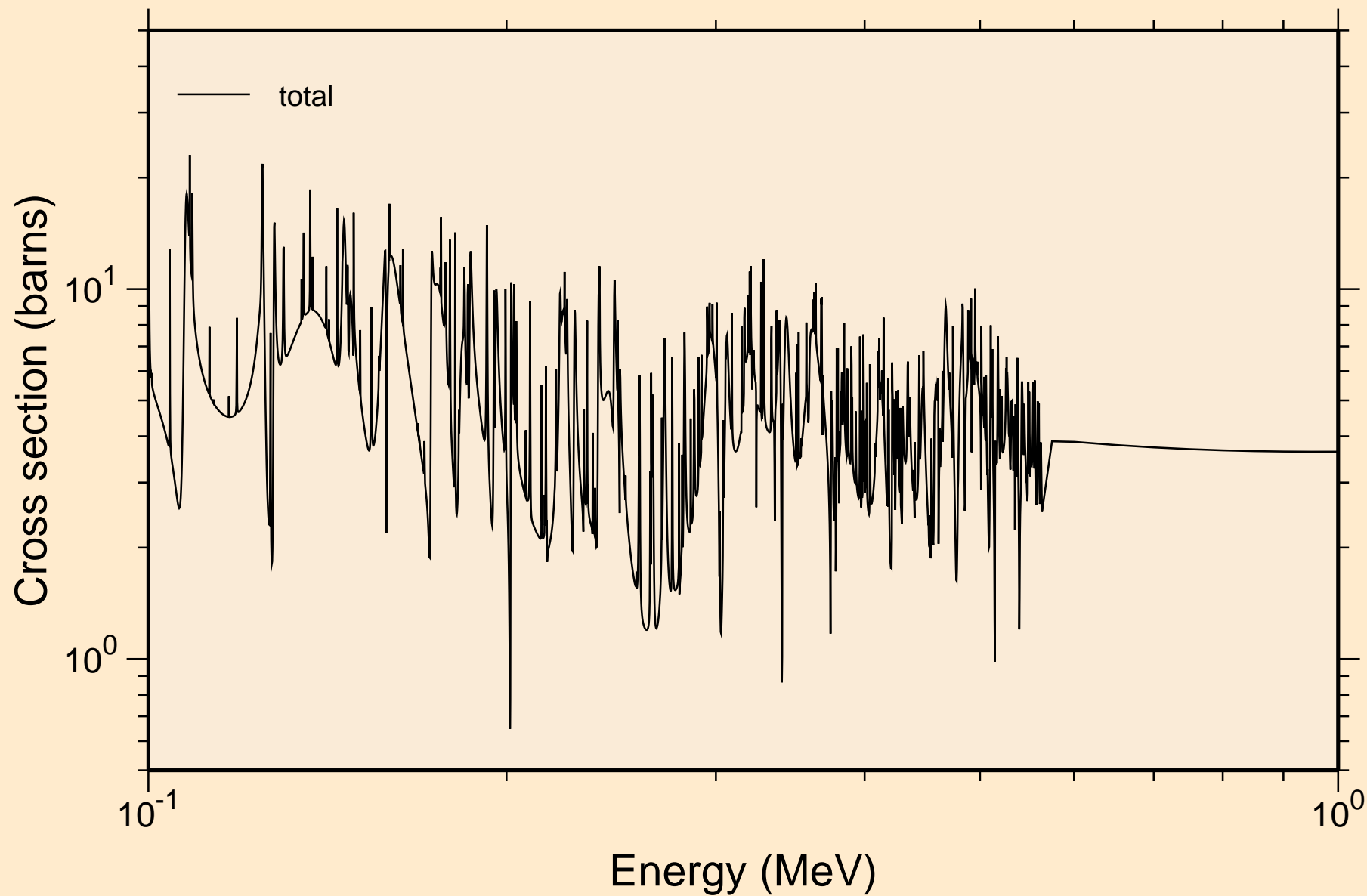

24-CR-53 FOR FENDL-3.1 FROM KIT-2010 WITH NJOY2012.50+ C
resonance absorption cross sections

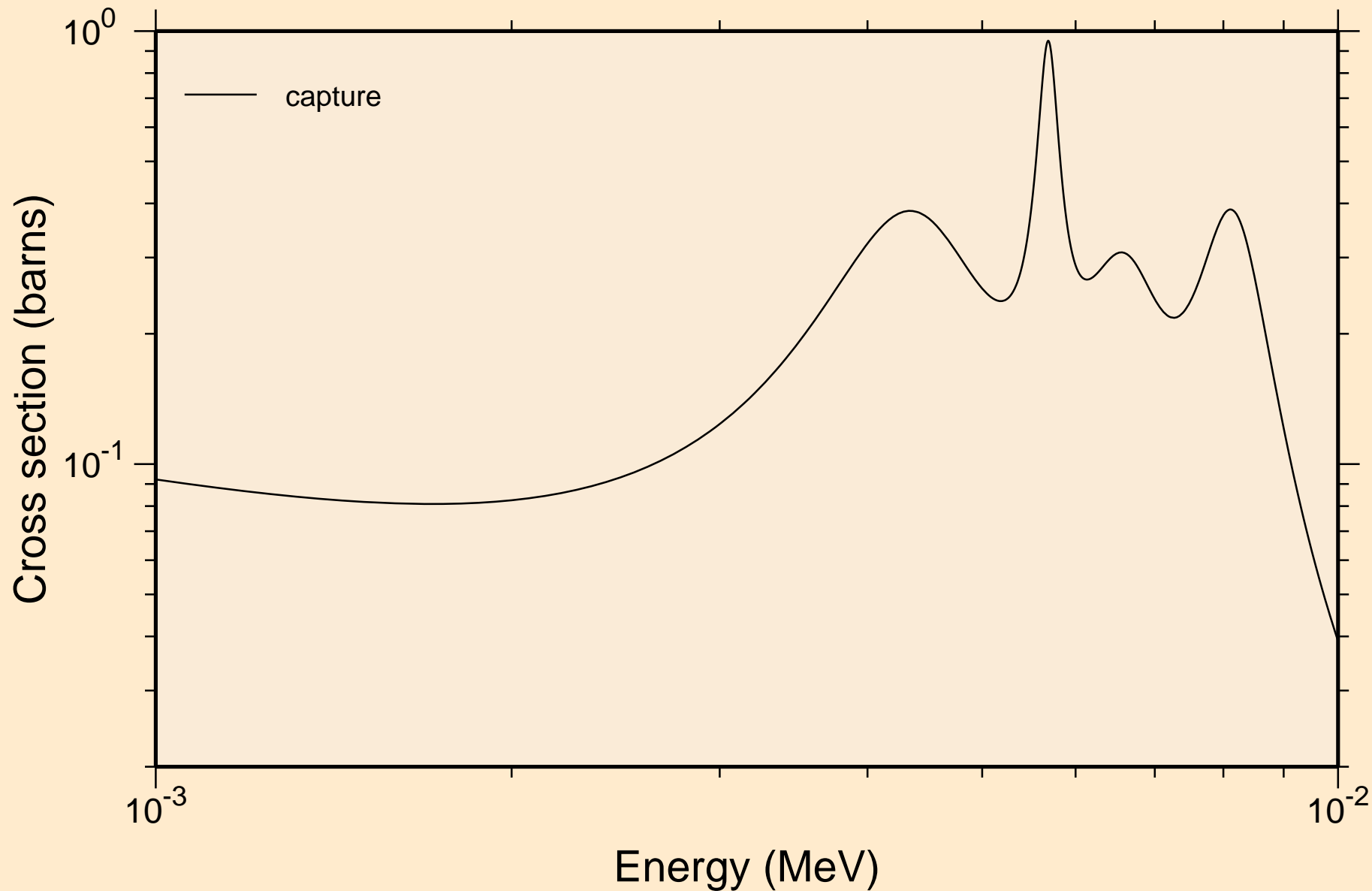

24-CR-53 FOR FENDL-3.1 FROM KIT-2010 WITH NJOY2012.50+ C resonance absorption cross sections

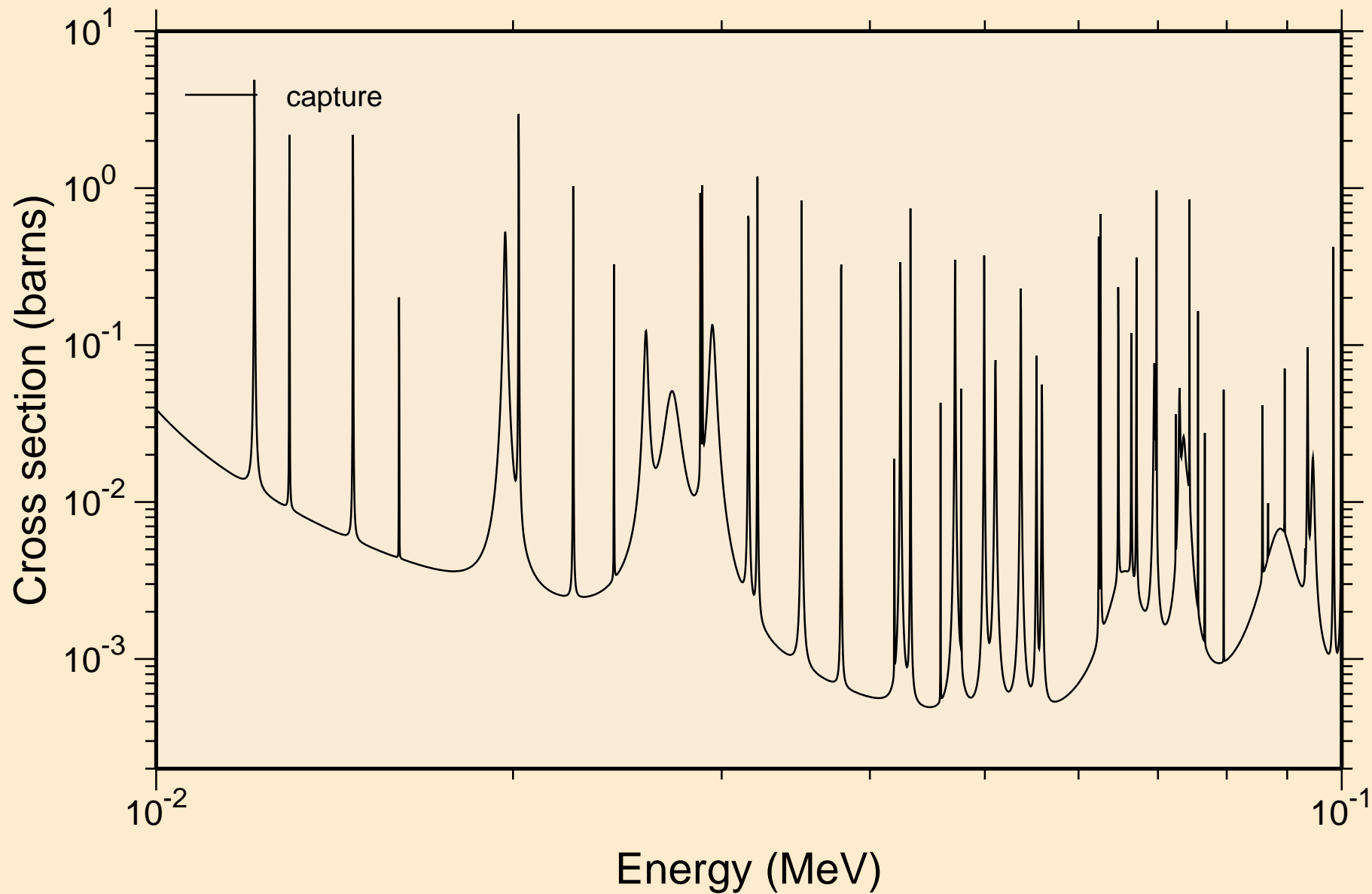

24-CR-53 FOR FENDL-3.1 FROM KIT-2010 WITH NJOY2012.50+ C resonance absorption cross sections

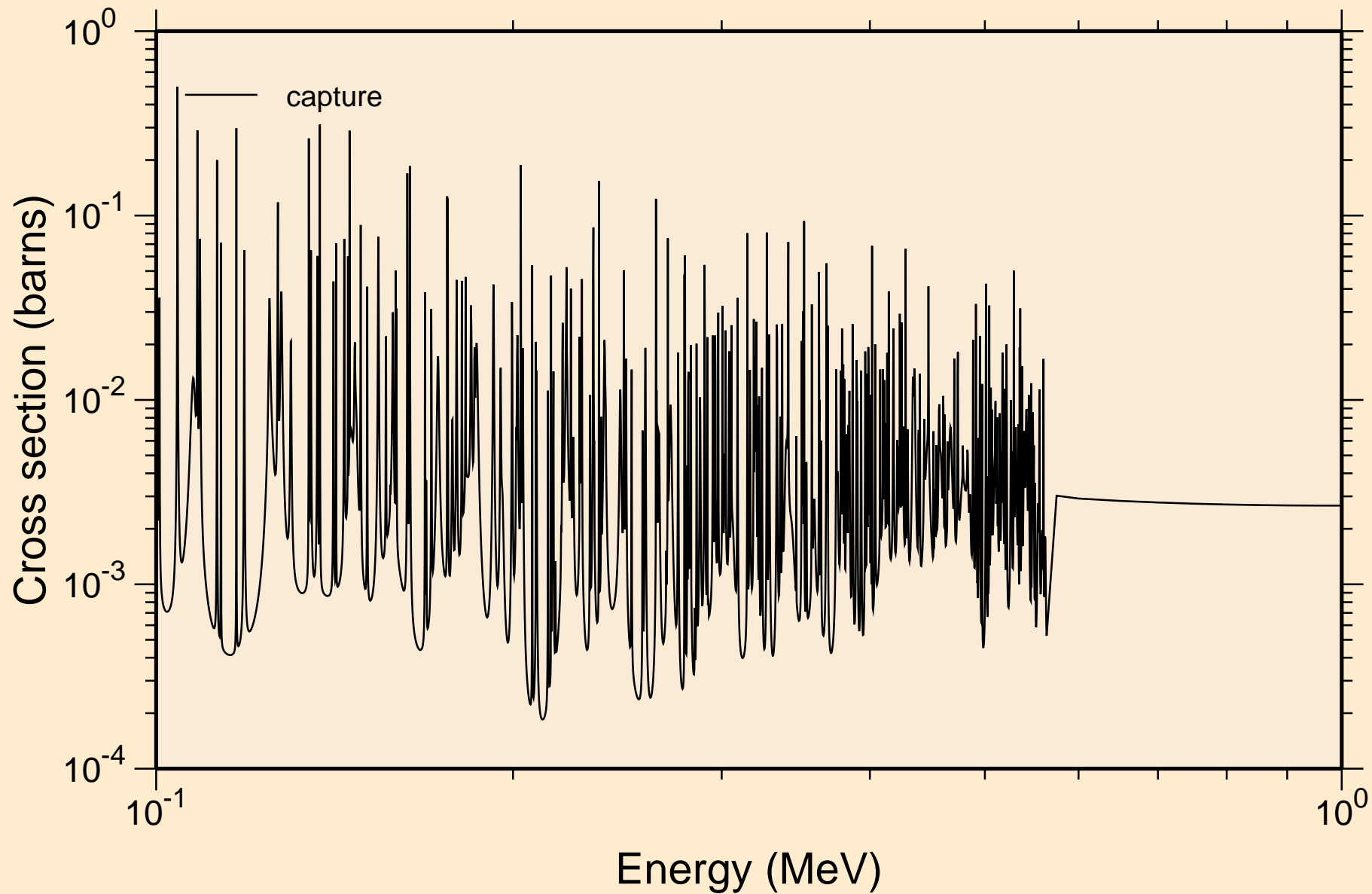

24-CR-53 FOR FENDL-3.1 FROM KIT-2010 WITH NJOY2012.50+ C Heating

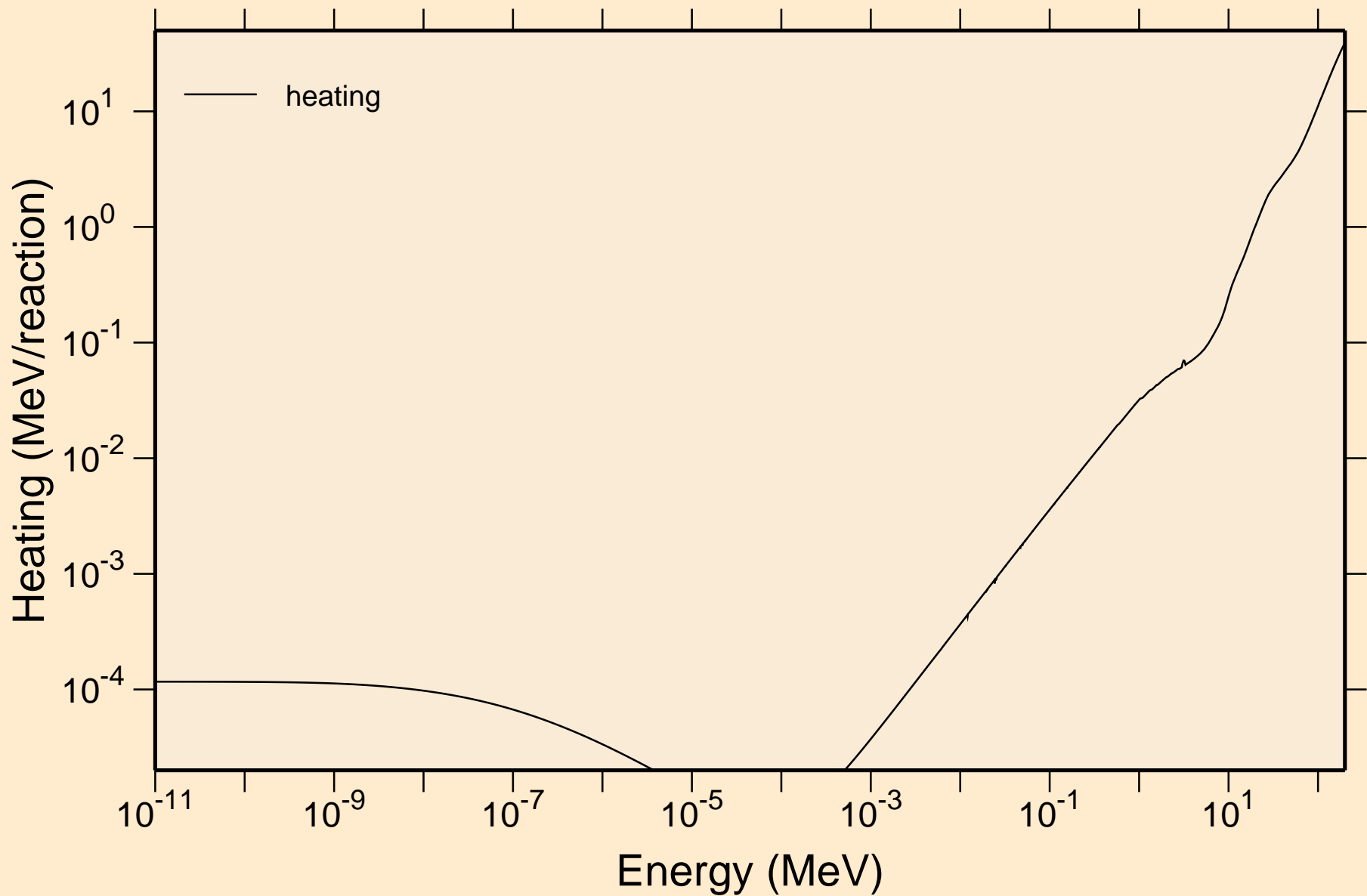

24-CR-53 FOR FENDL-3.1 FROM KIT-2010 WITH NJOY2012.50+ C Damage

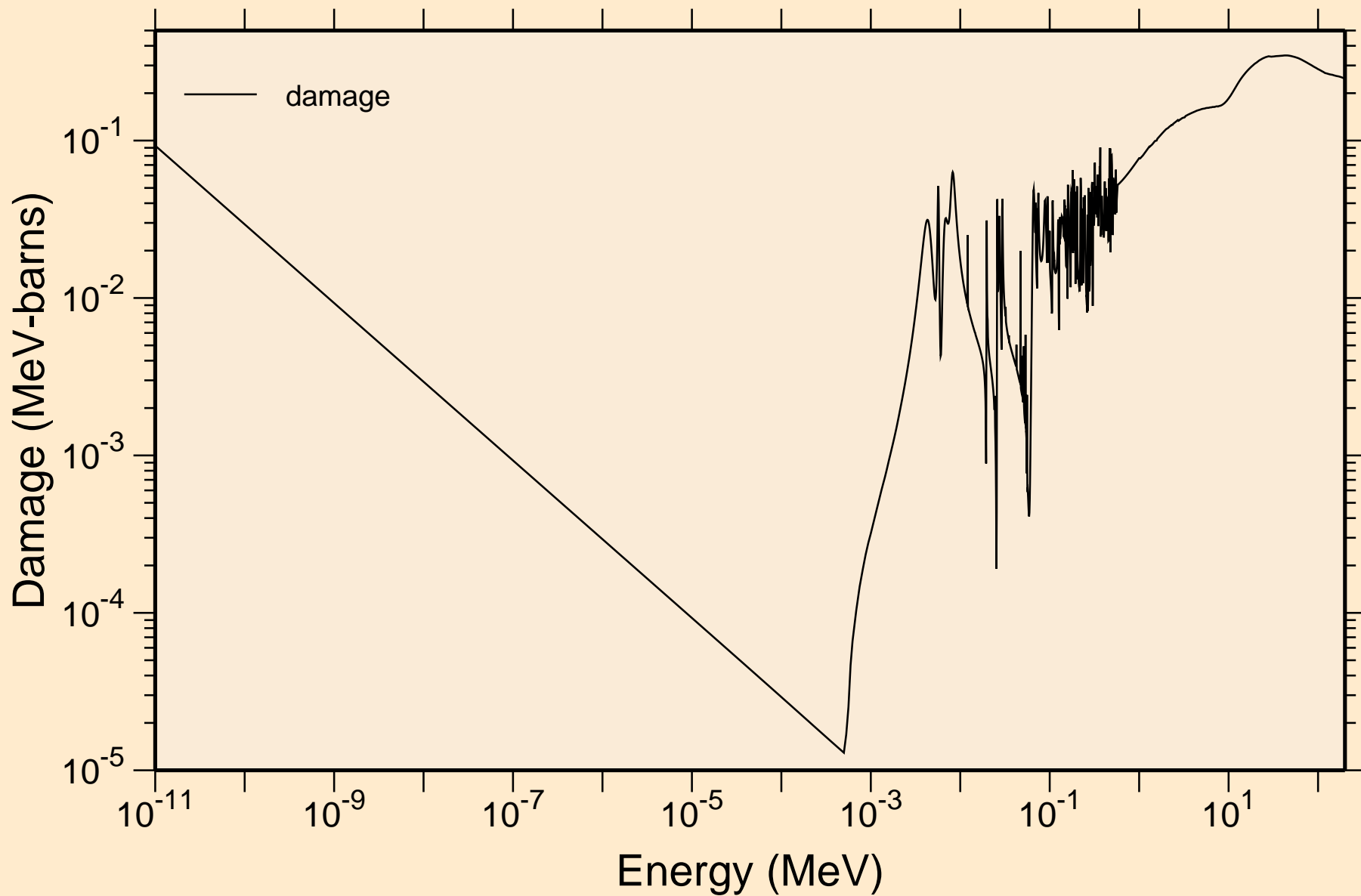

24-CR-53 FOR FENDL-3.1 FROM KIT-2010 WITH NJOY2012.50+ C
Non-threshold reactions

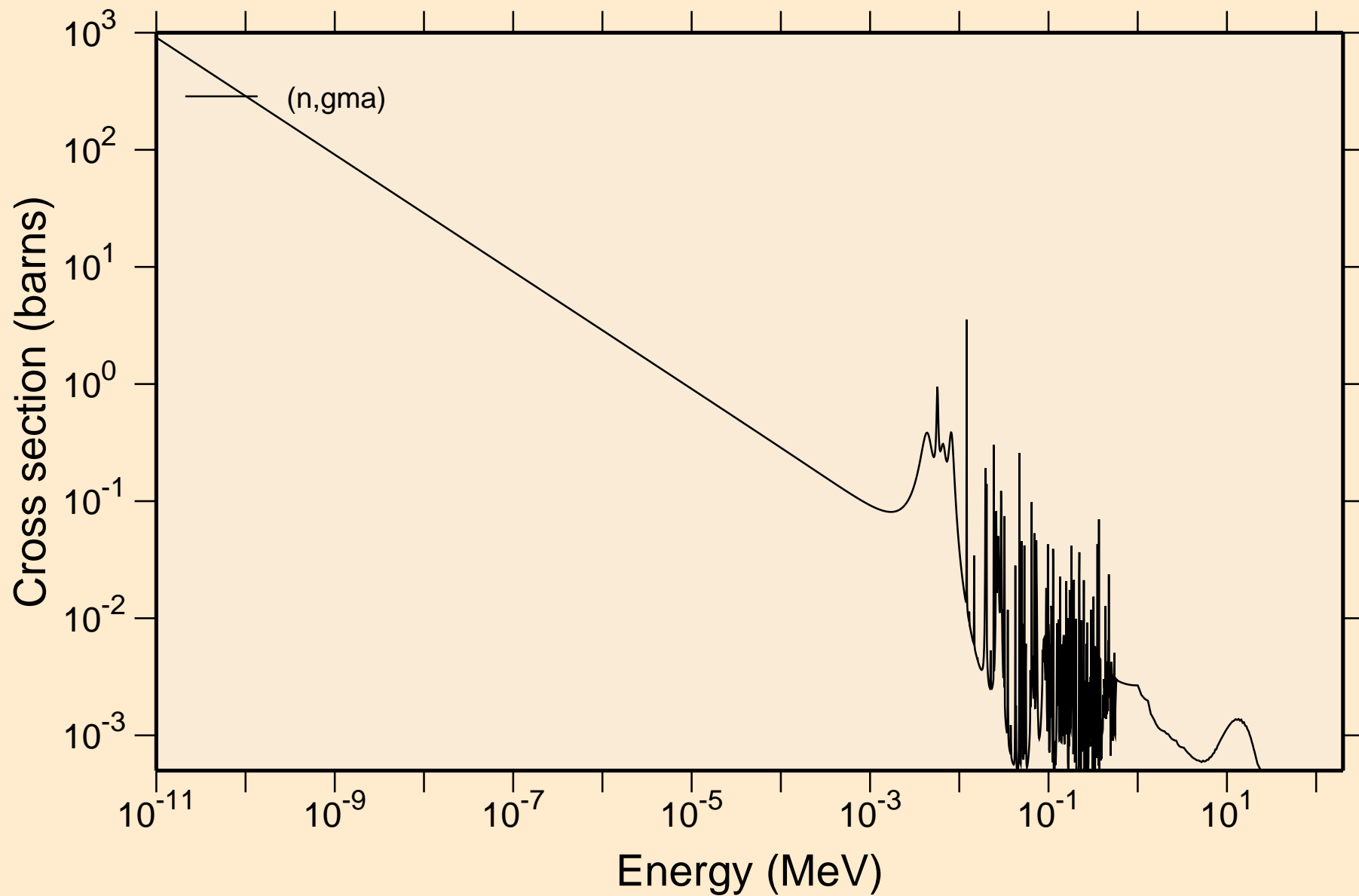

24-CR-53 FOR FENDL-3.1 FROM KIT-2010 WITH NJOY2012.50+ C

Principal cross sections

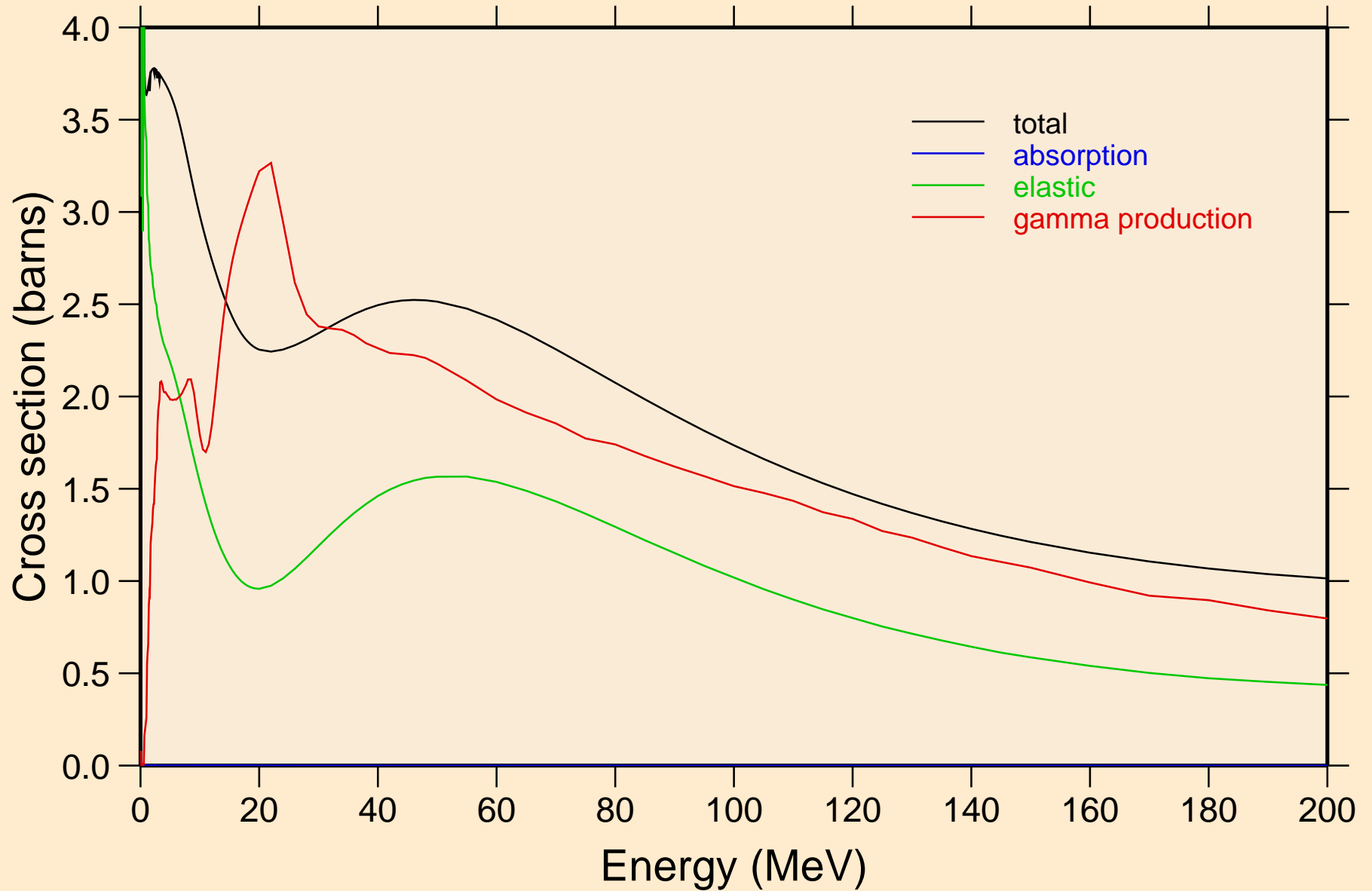

24-CR-53 FOR FENDL-3.1 FROM KIT-2010 WITH NJOY2012.50+ C Heating

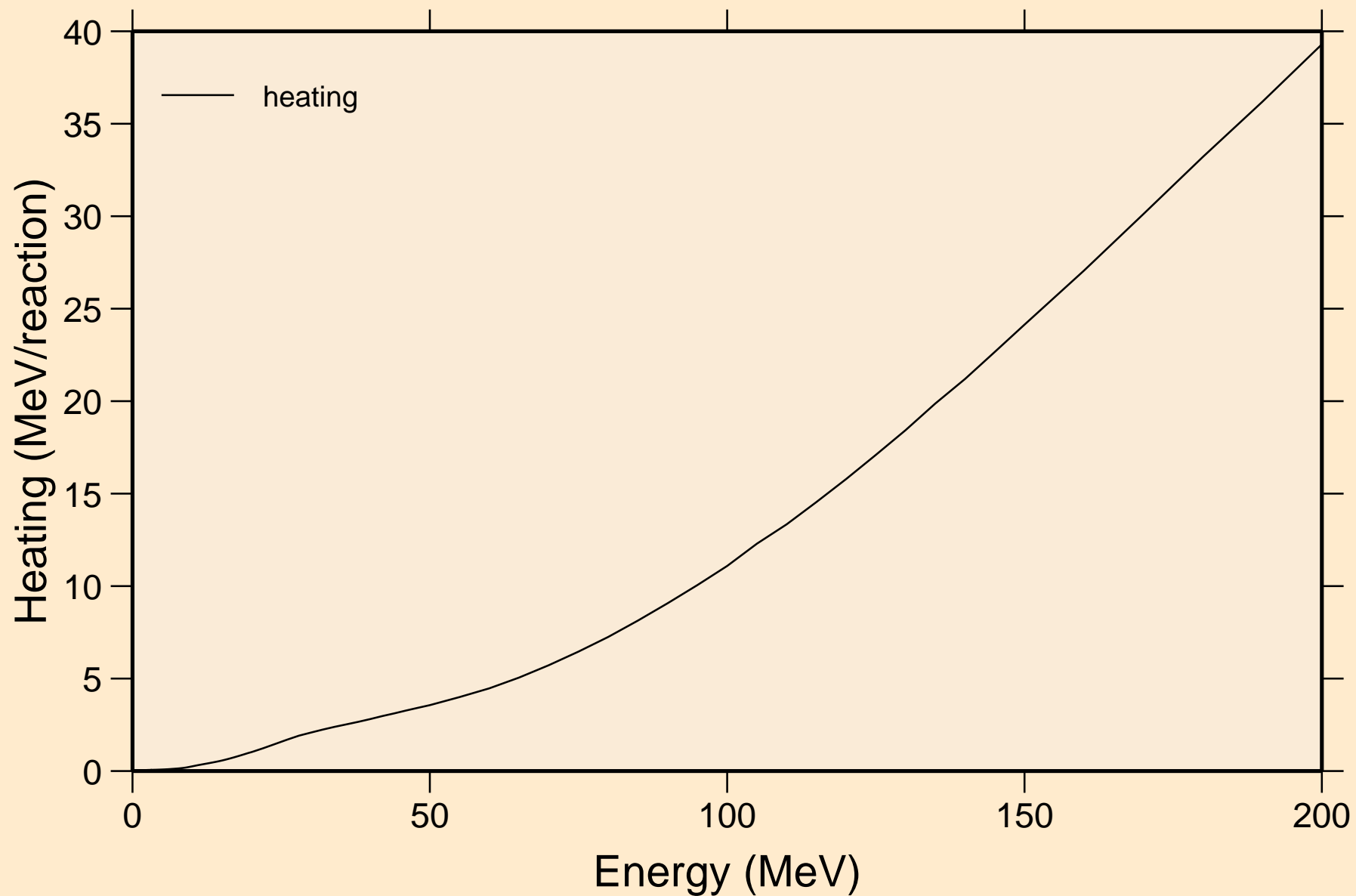

24-CR-53 FOR FENDL-3.1 FROM KIT-2010 WITH NJOY2012.50+ C Damage

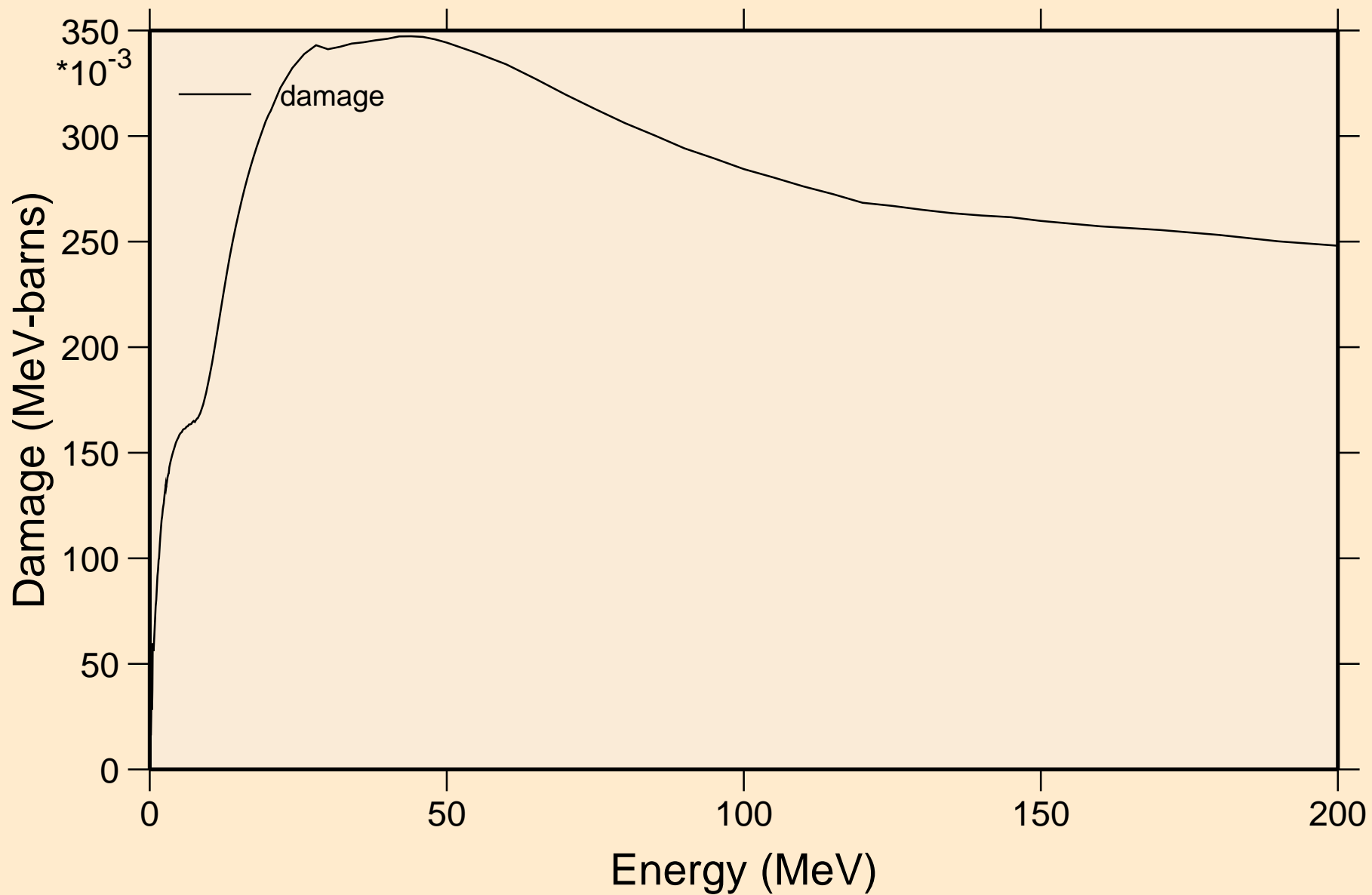

24-CR-53 FOR FENDL-3.1 FROM KIT-2010 WITH NJOY2012.50+ C
Non-threshold reactions

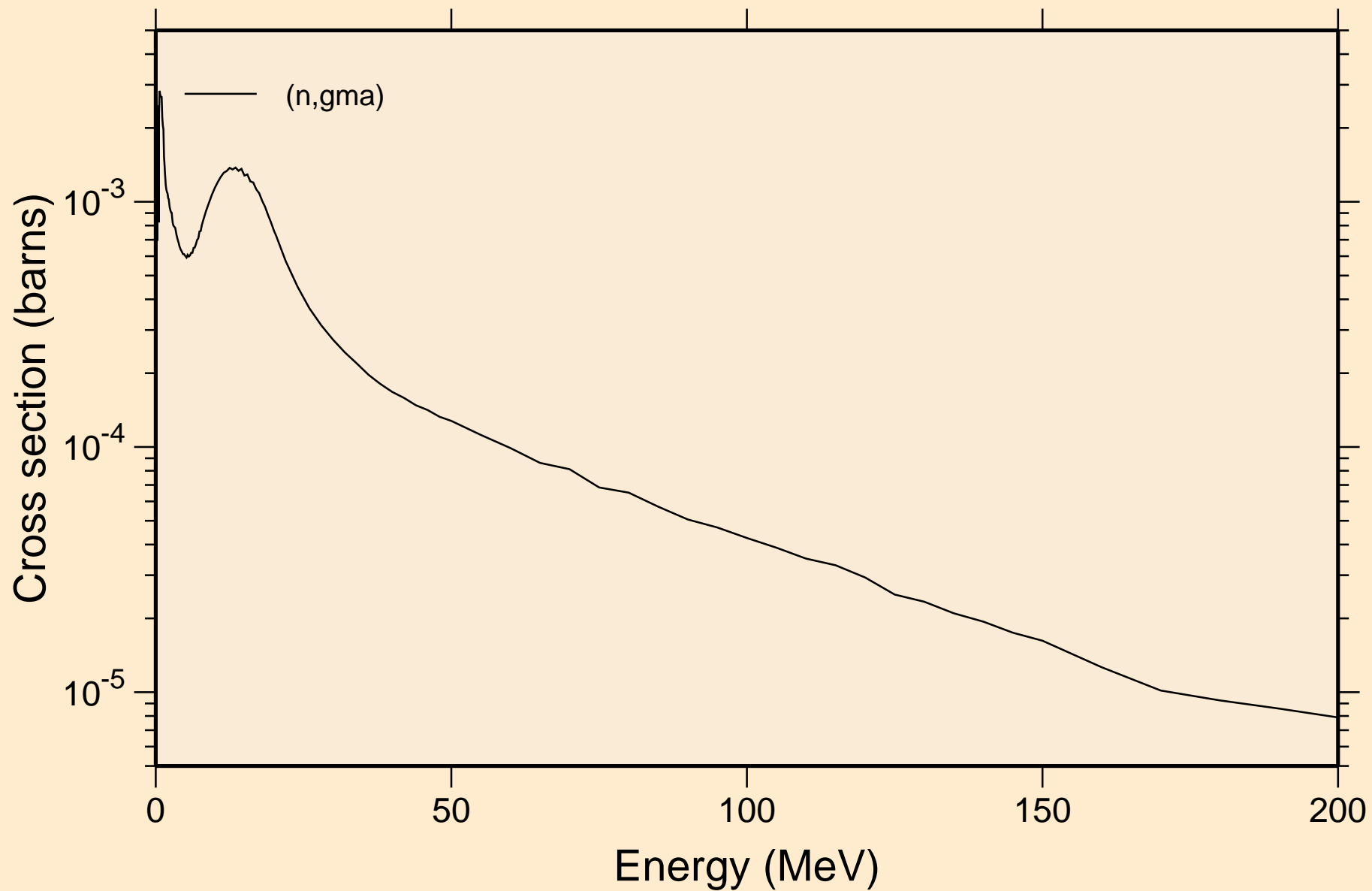

24-CR-53 FOR FENDL-3.1 FROM KIT-2010 WITH NJOY2012.50+ C Inelastic levels

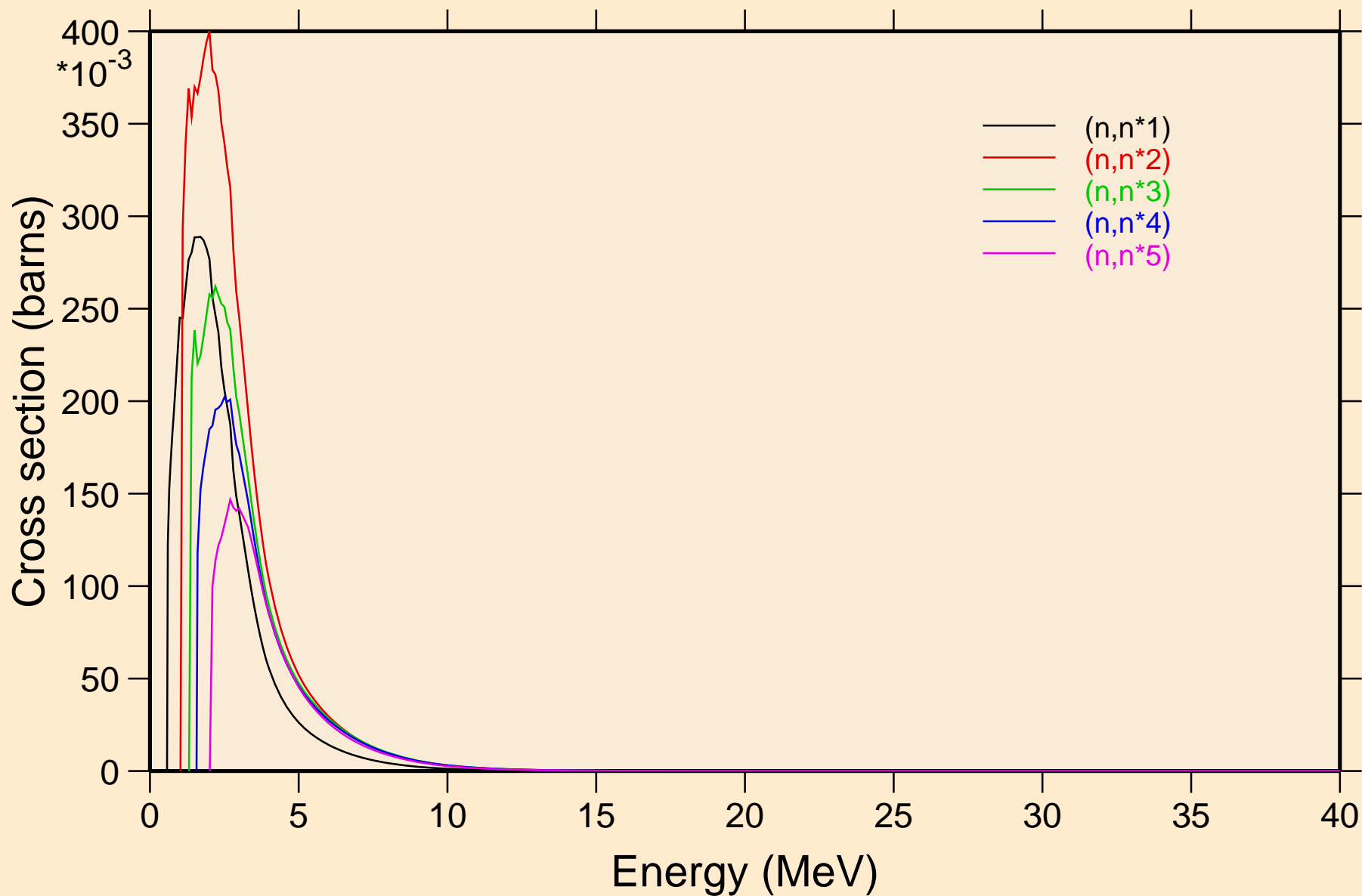

24-CR-53 FOR FENDL-3.1 FROM KIT-2010 WITH NJOY2012.50+ C Inelastic levels

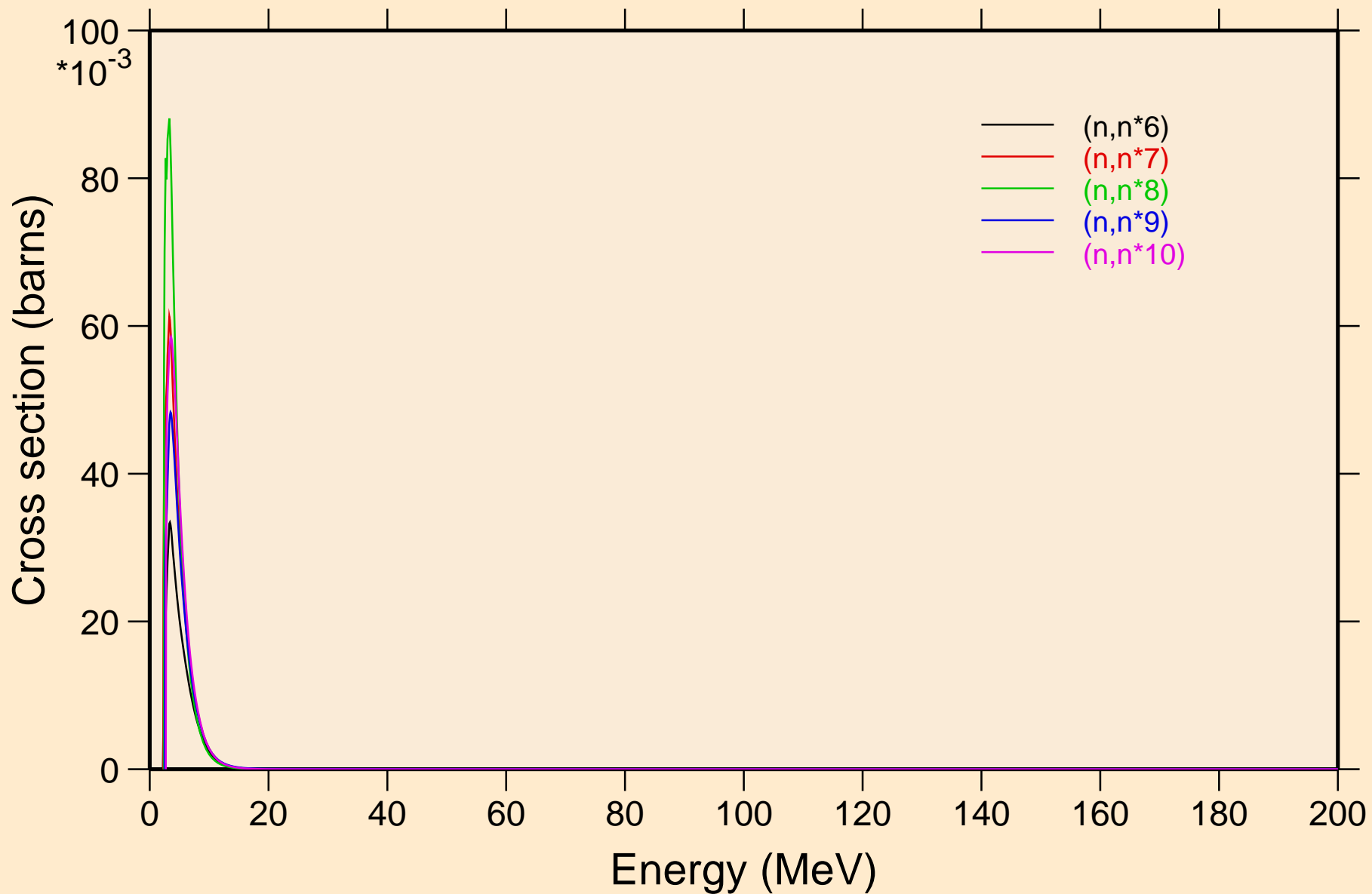

24-CR-53 FOR FENDL-3.1 FROM KIT-2010 WITH NJOY2012.50+ C Inelastic levels

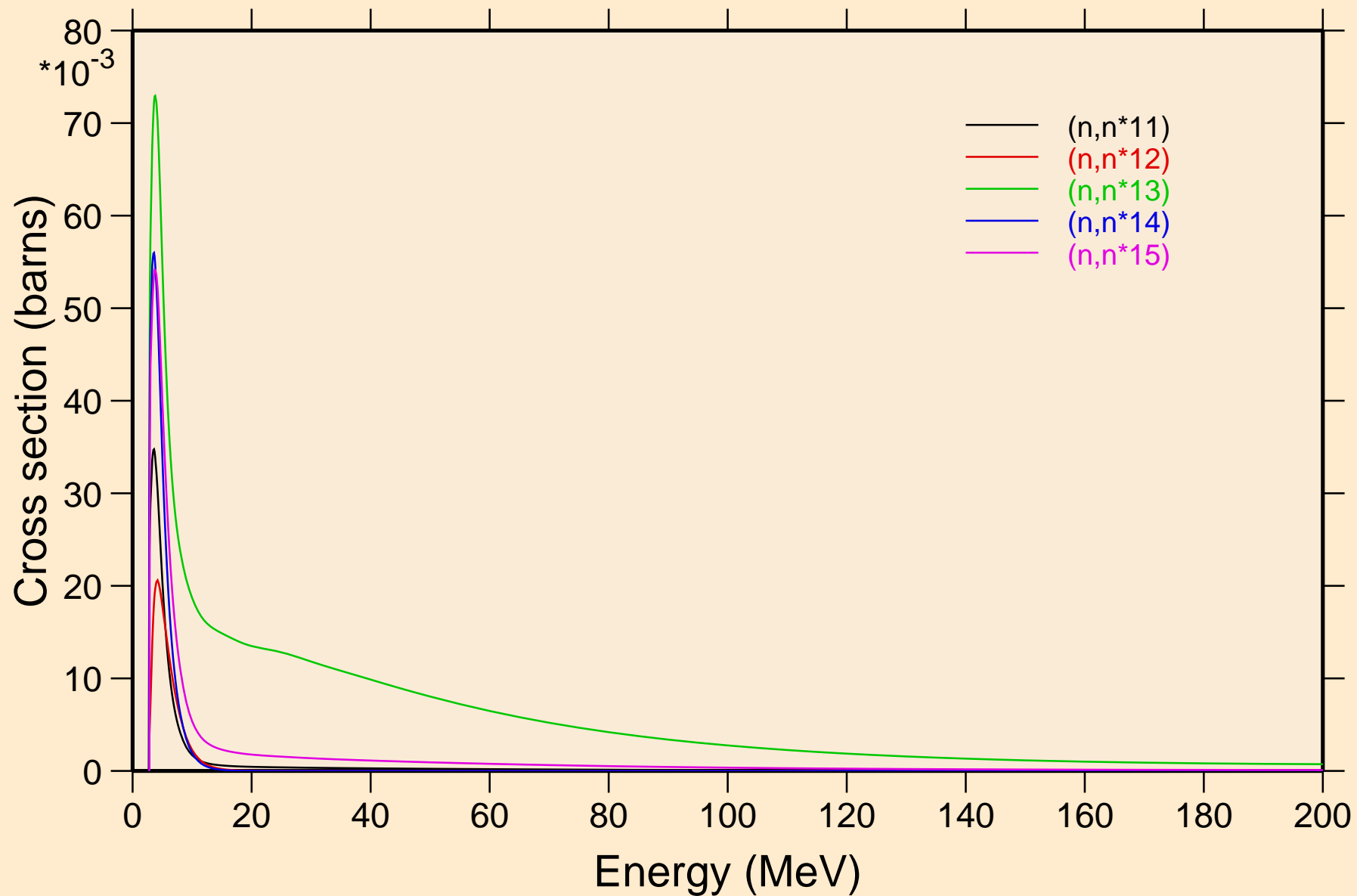

24-CR-53 FOR FENDL-3.1 FROM KIT-2010 WITH NJOY2012.50+ C Inelastic levels

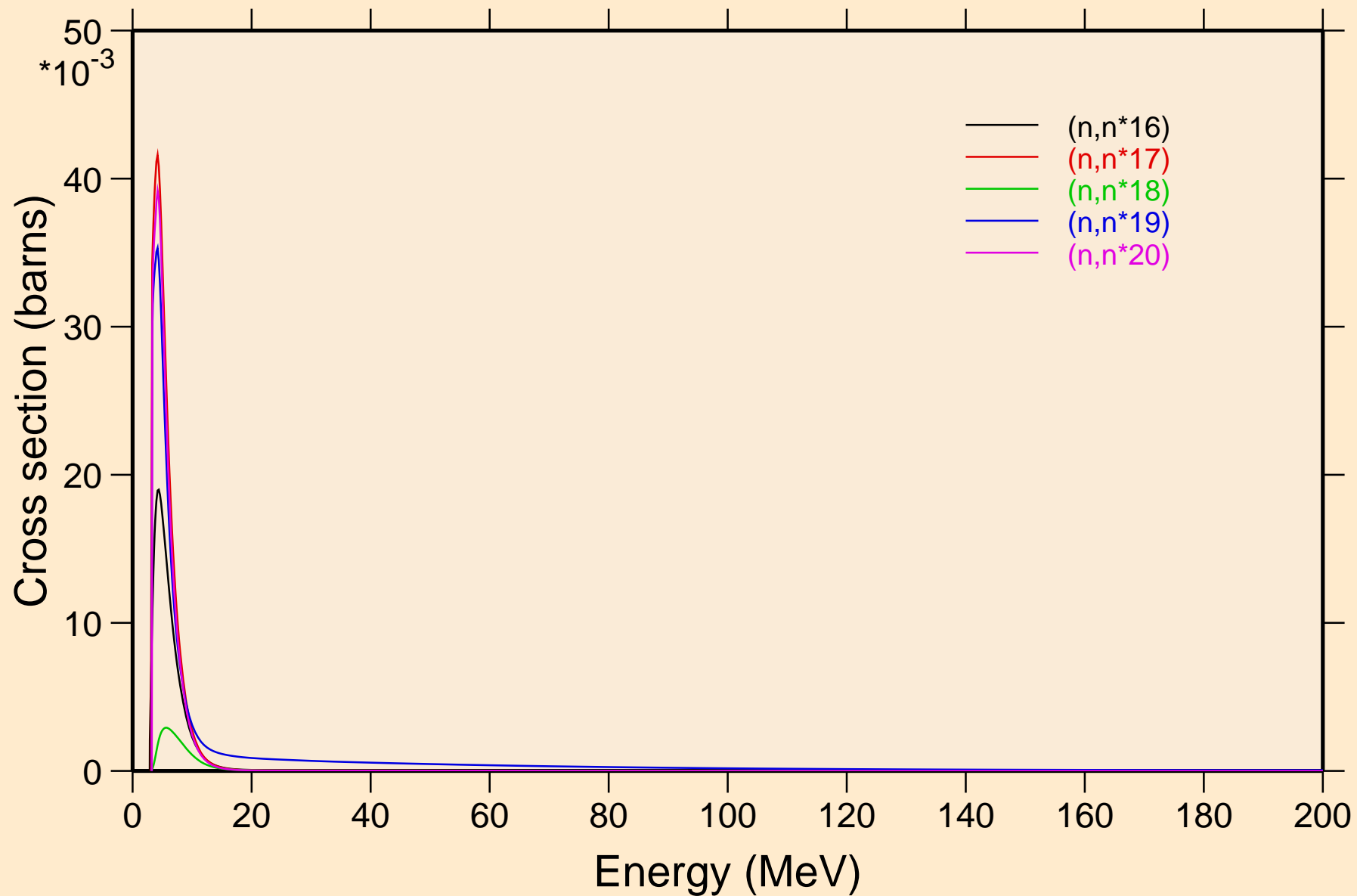

24-CR-53 FOR FENDL-3.1 FROM KIT-2010 WITH NJOY2012.50+ C Threshold reactions

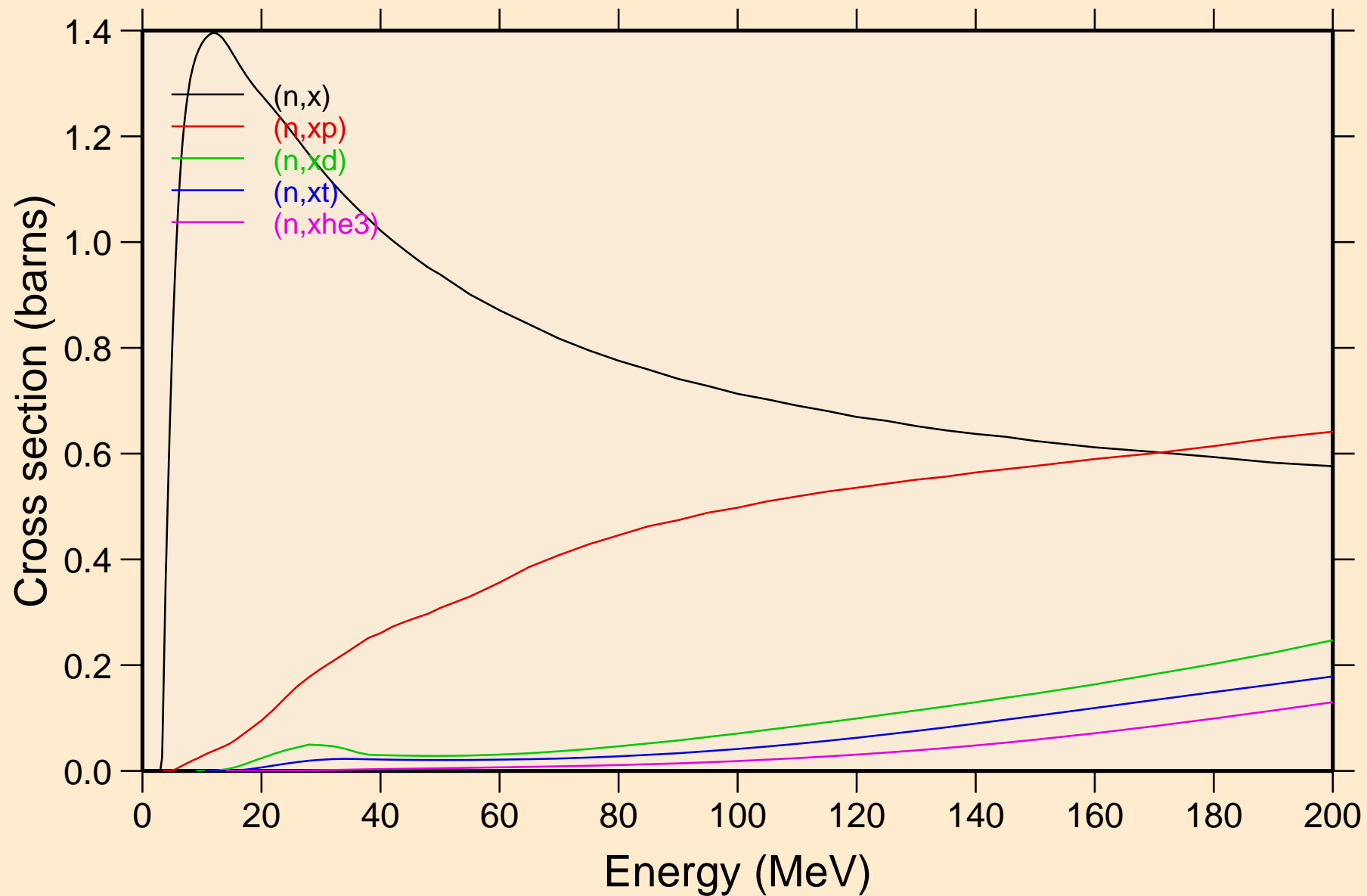

24-CR-53 FOR FENDL-3.1 FROM KIT-2010 WITH NJOY2012.50+ C Threshold reactions

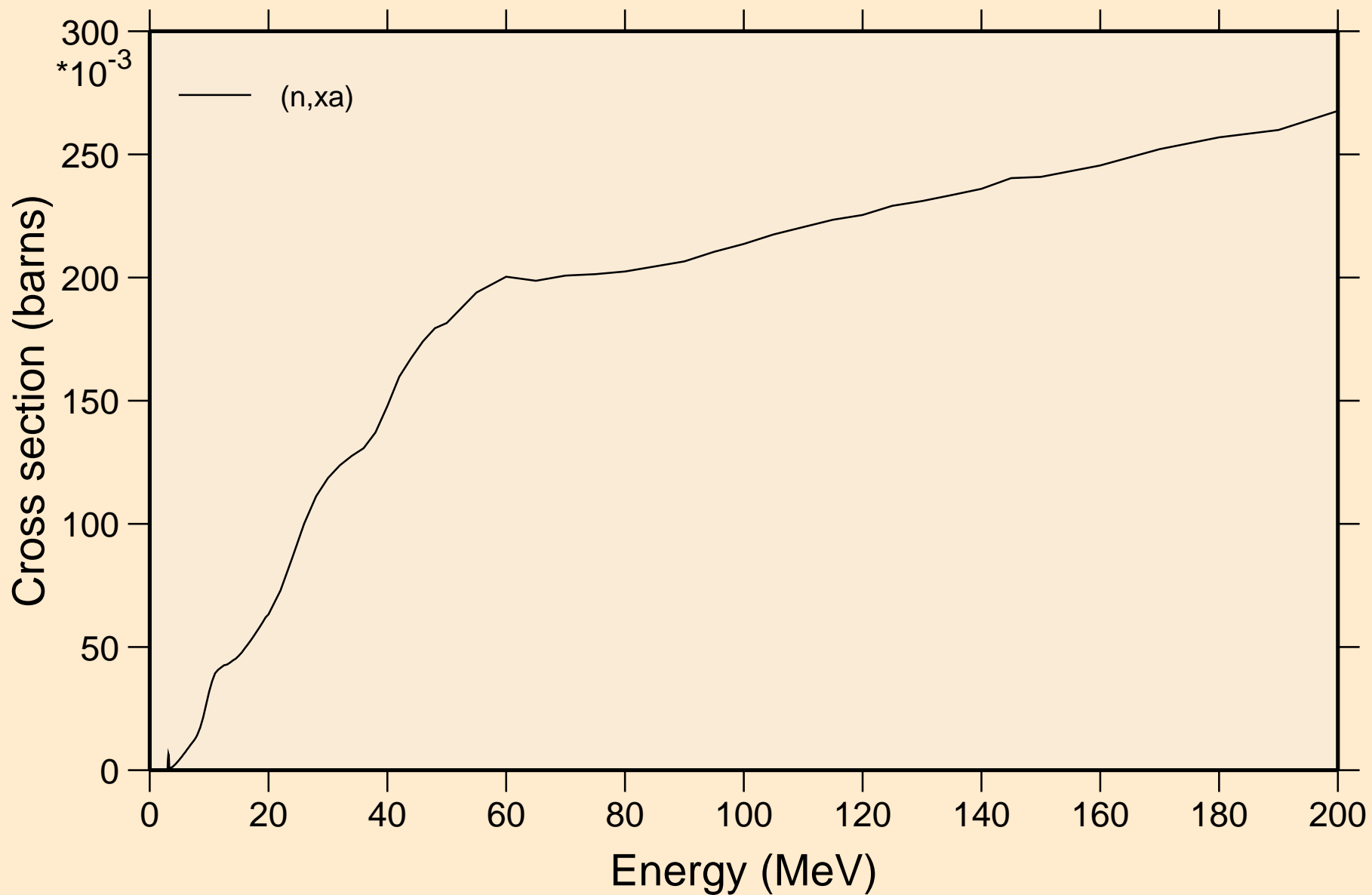

24-CR-53 FOR FENDL-3.1 FROM KIT-2010 WITH NJOY2012.50+ C
angular distribution for elastic

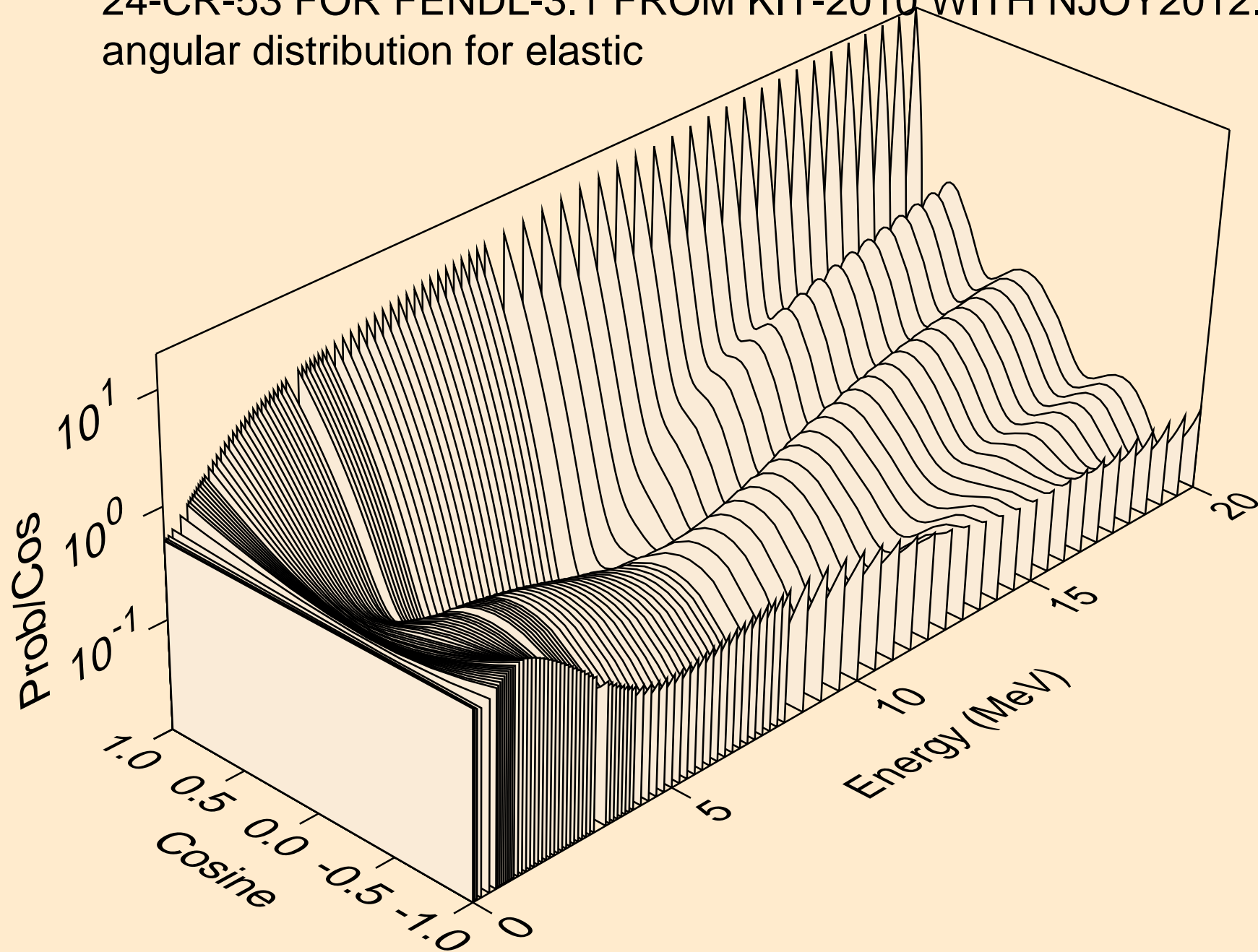

24-CR-53 FOR FENDL-3.1 FROM KIT-2010 WITH NJOY2012.50+ C
angular distribution for elastic

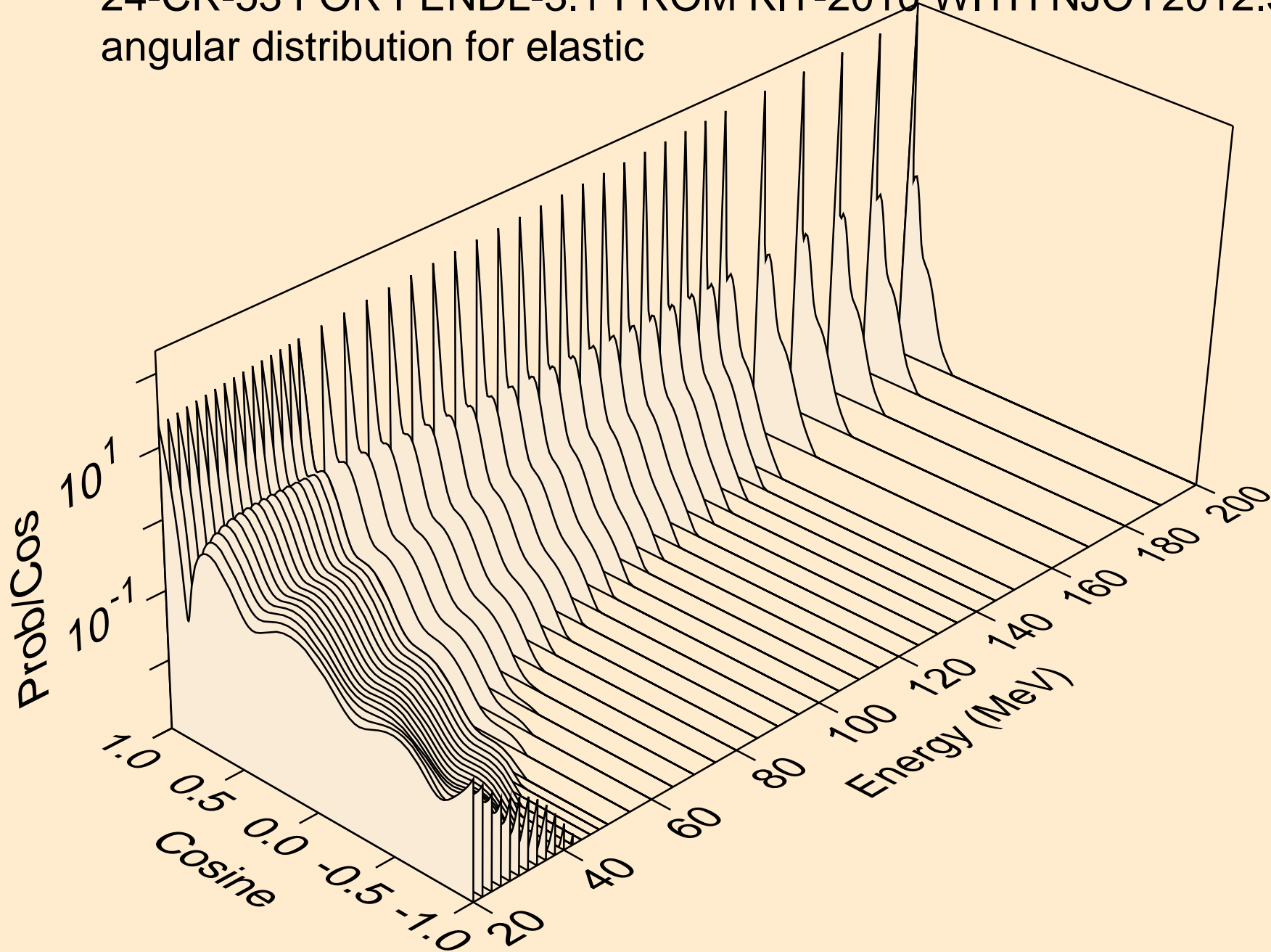

24-CR-53 FOR FENDL-3.1 FROM KIT-2010 WITH NJOY2012.50+ C
angular distribution for (n,n*1)

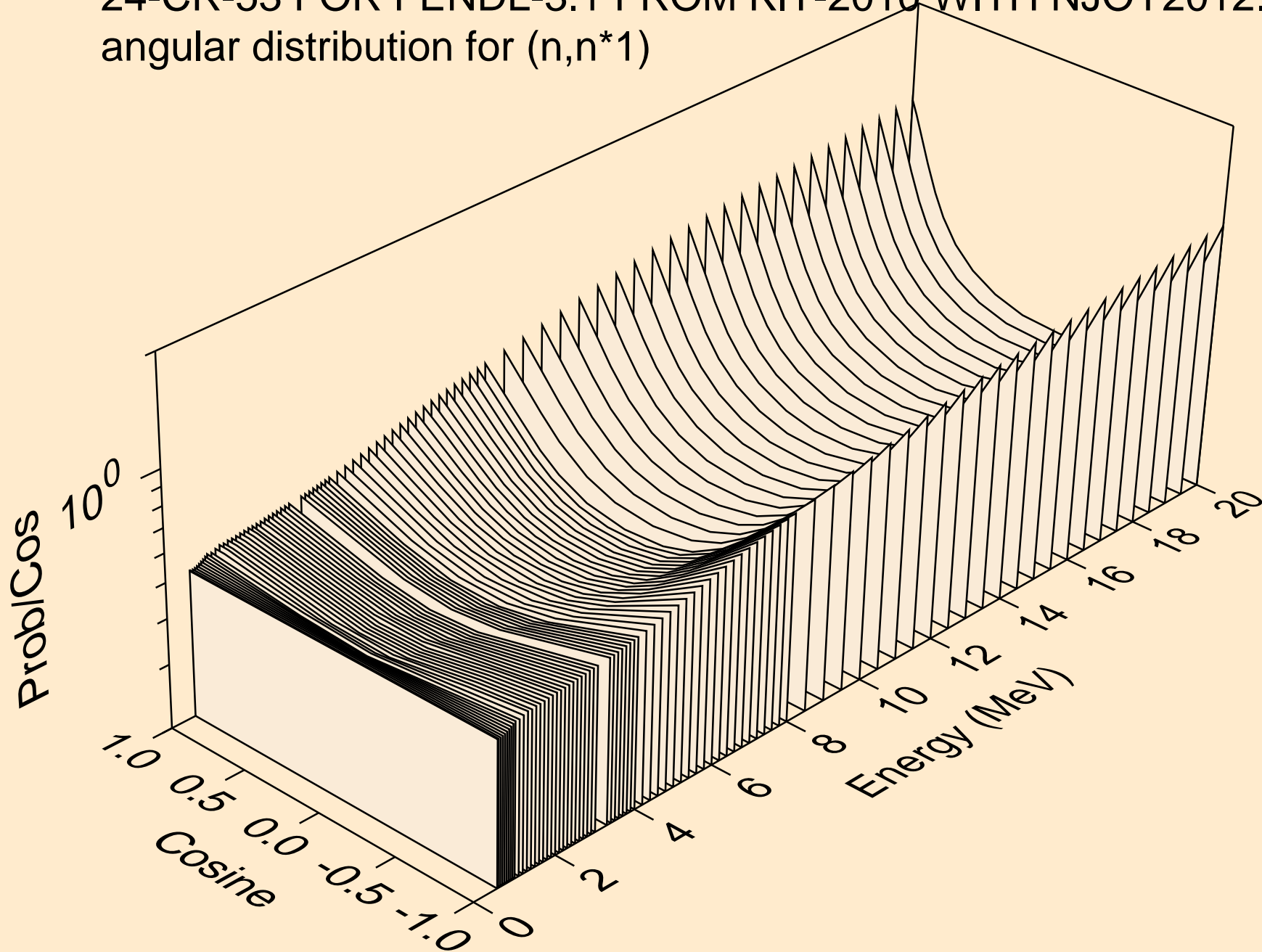

24-CR-53 FOR FENDL-3.1 FROM KIT-2010 WITH NJOY2012.50+ C
angular distribution for (n,n*1)

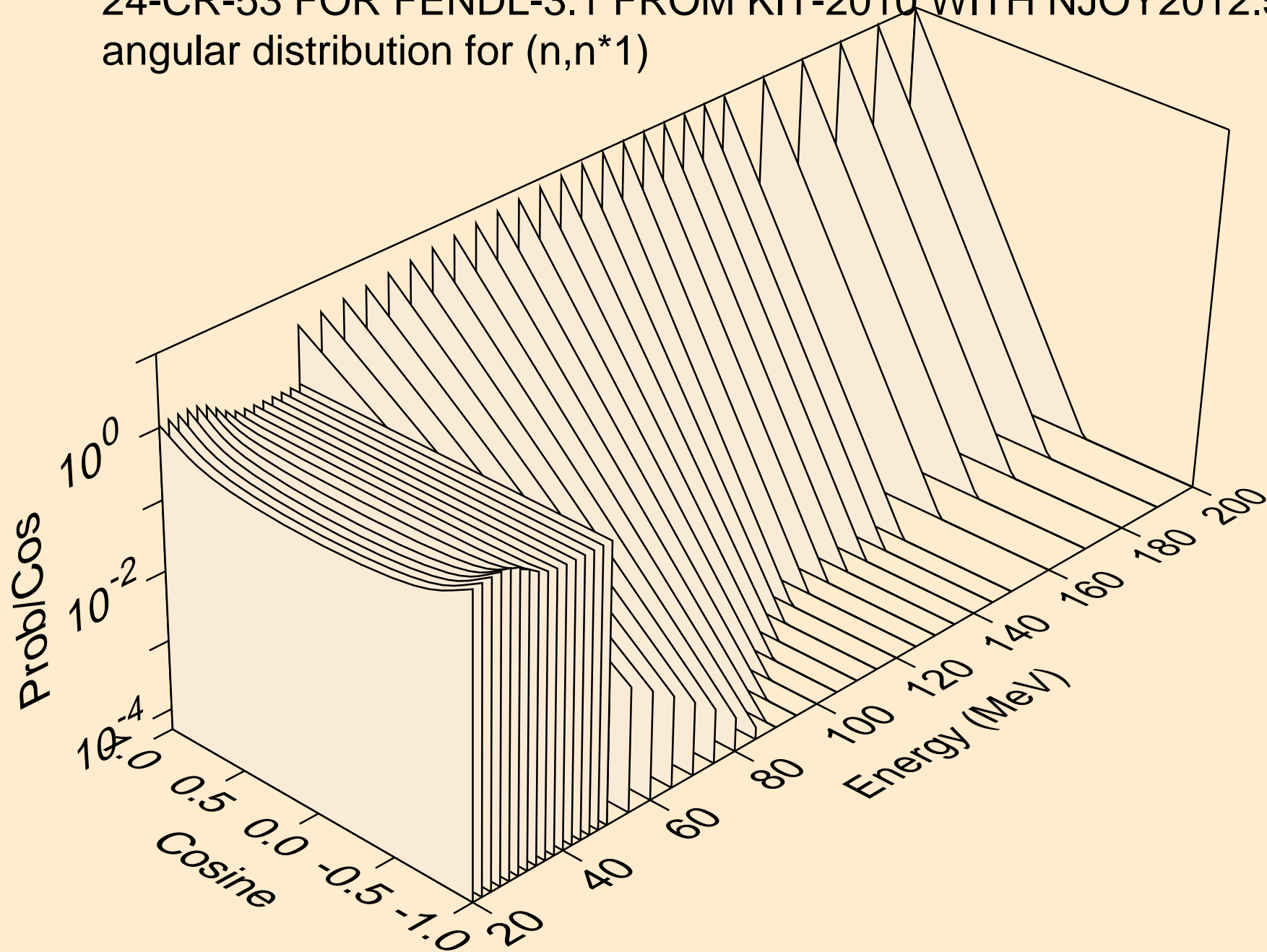

24-CR-53 FOR FENDL-3.1 FROM KIT-2010 WITH NJOY2012.50+ C
angular distribution for (n,n*2)

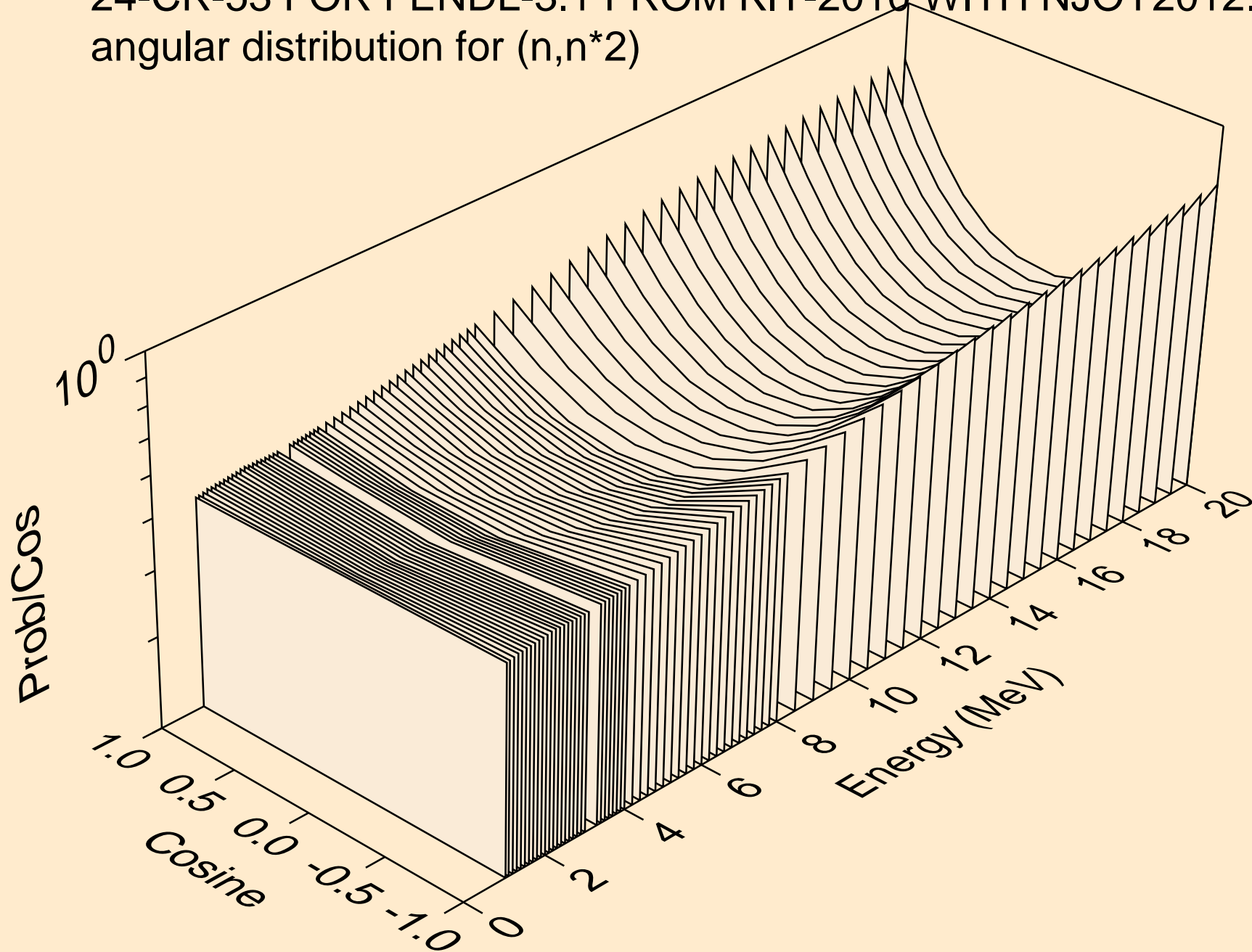

24-CR-53 FOR FENDL-3.1 FROM KIT-2010 WITH NJOY2012.50+ C
angular distribution for (n,n*2)

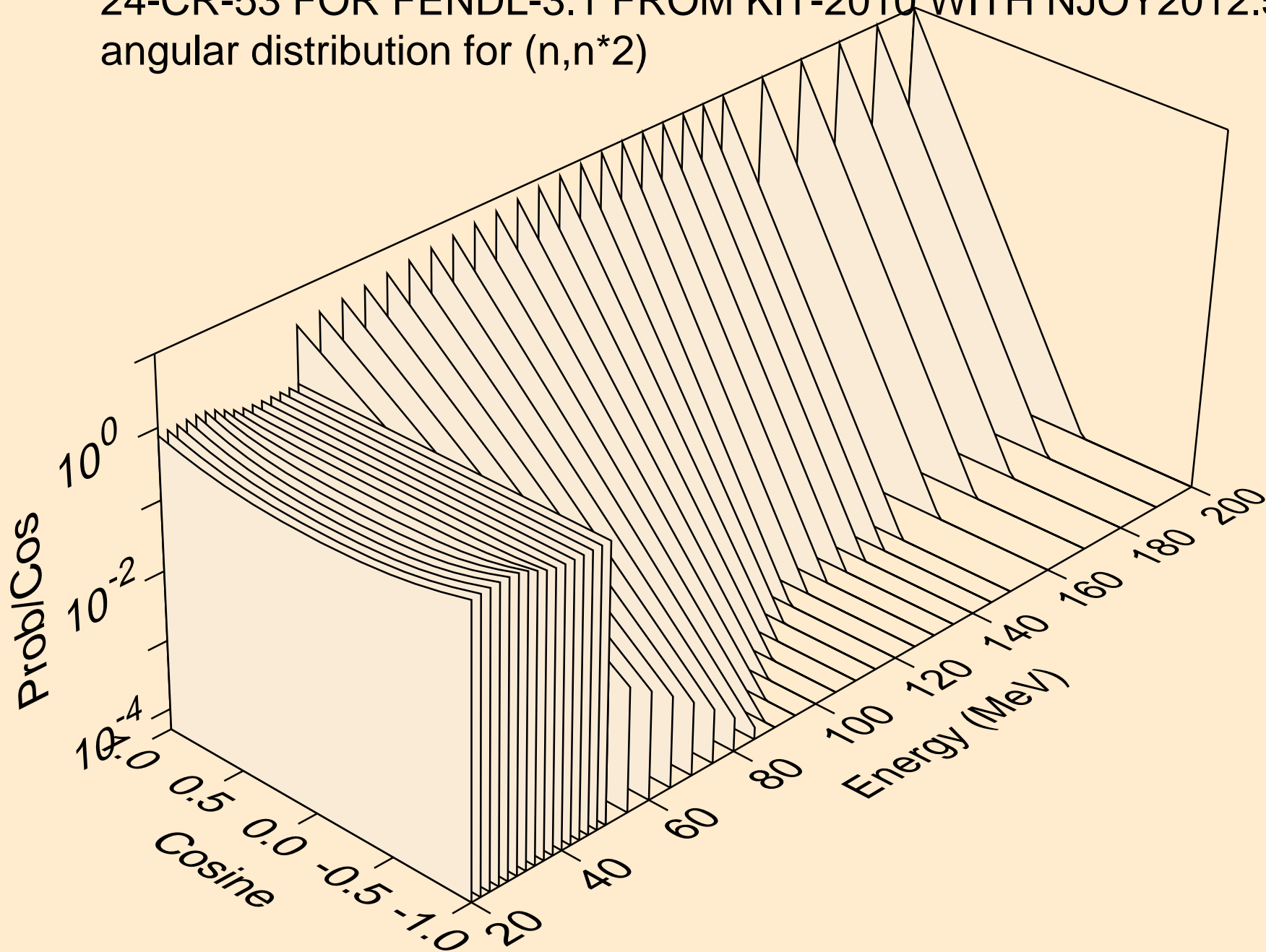

24-CR-53 FOR FENDL-3.1 FROM KIT-2010 WITH NJOY2012.50+ C
angular distribution for (n,n*3)

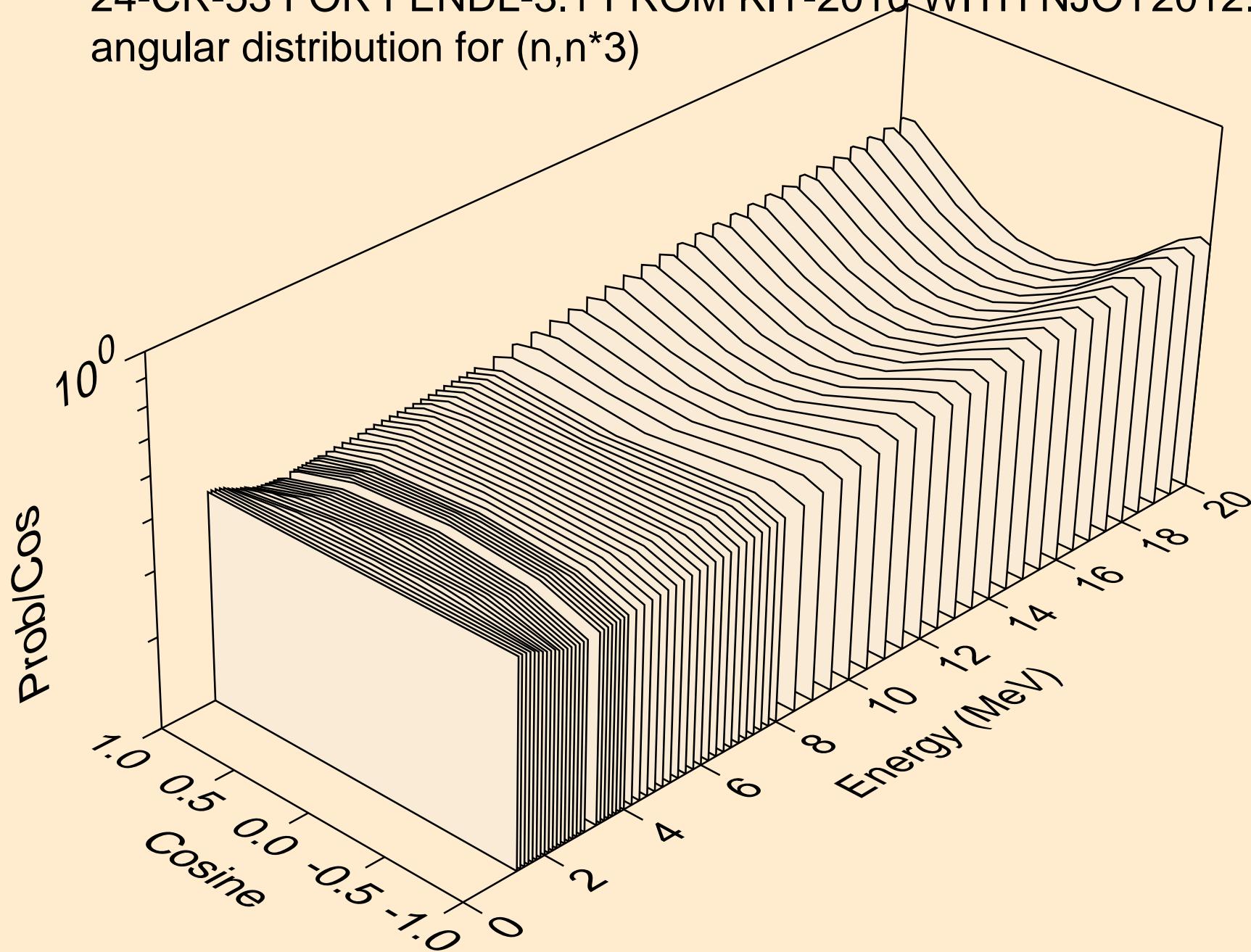

24-CR-53 FOR FENDL-3.1 FROM KIT-2010 WITH NJOY2012.50+ C
angular distribution for (n,n*3)

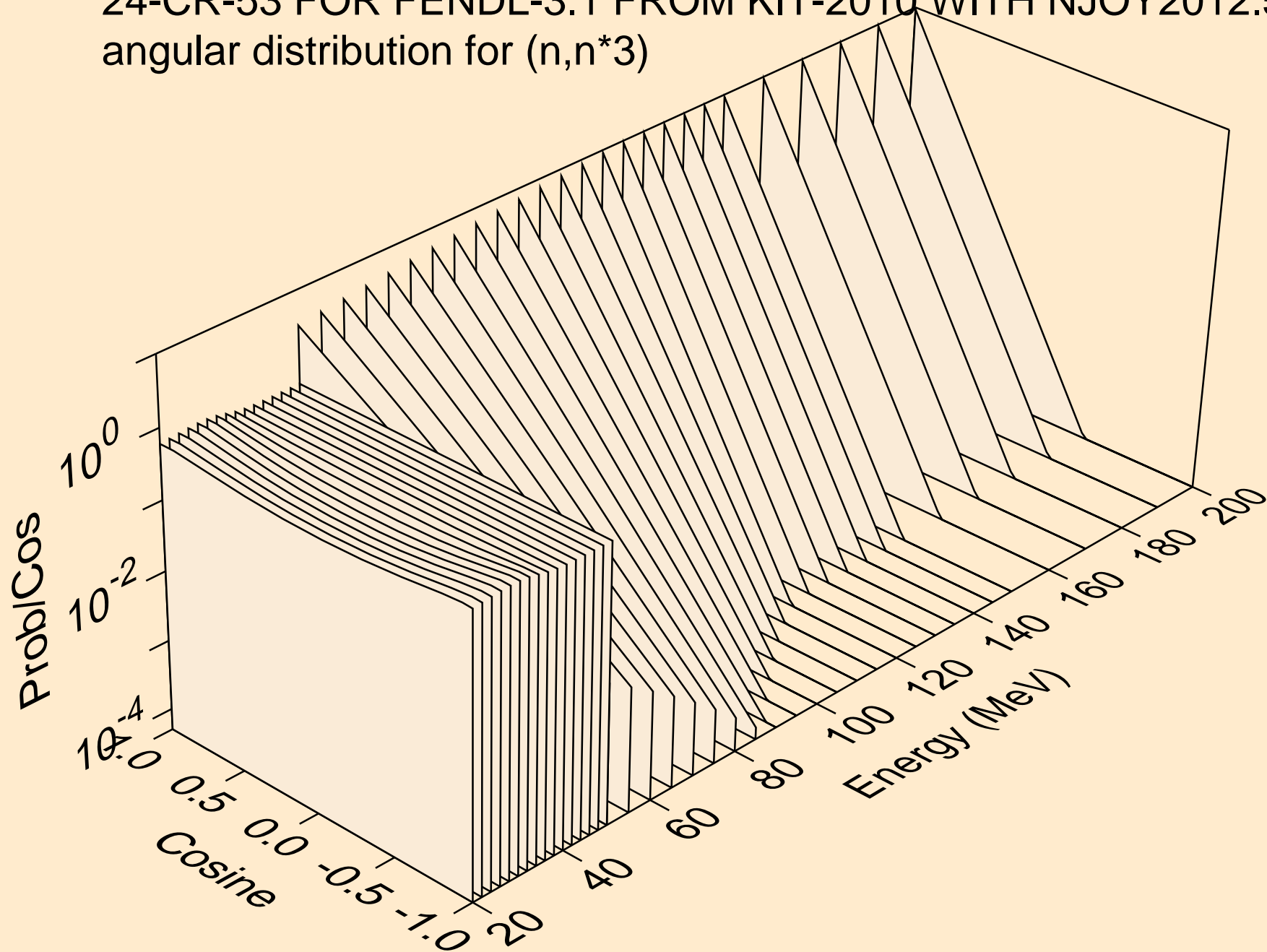

24-CR-53 FOR FENDL-3.1 FROM KIT-2010 WITH NJOY2012.50+ C
angular distribution for (n,n*4)

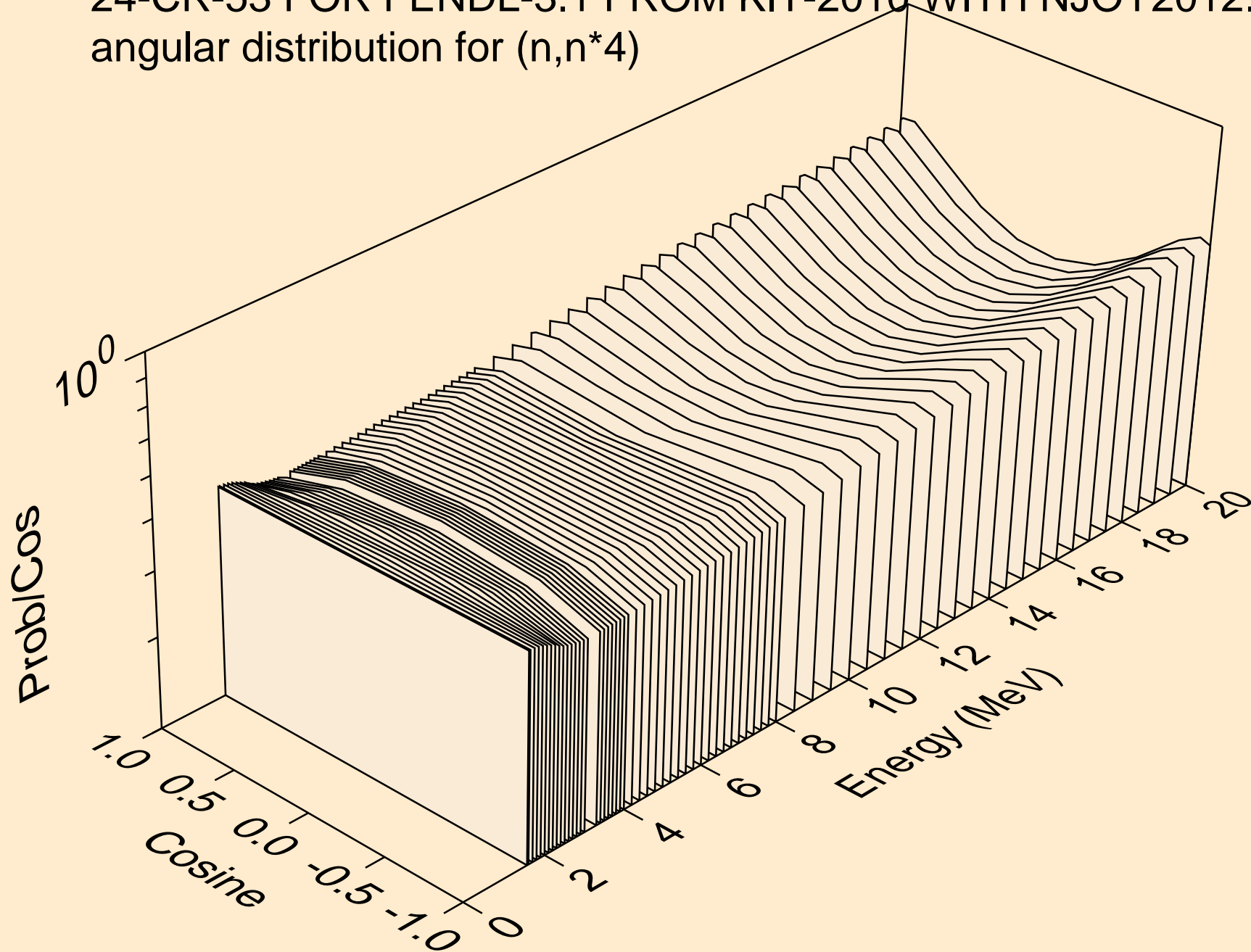

24-CR-53 FOR FENDL-3.1 FROM KIT-2010 WITH NJOY2012.50+ C
angular distribution for (n,n*4)

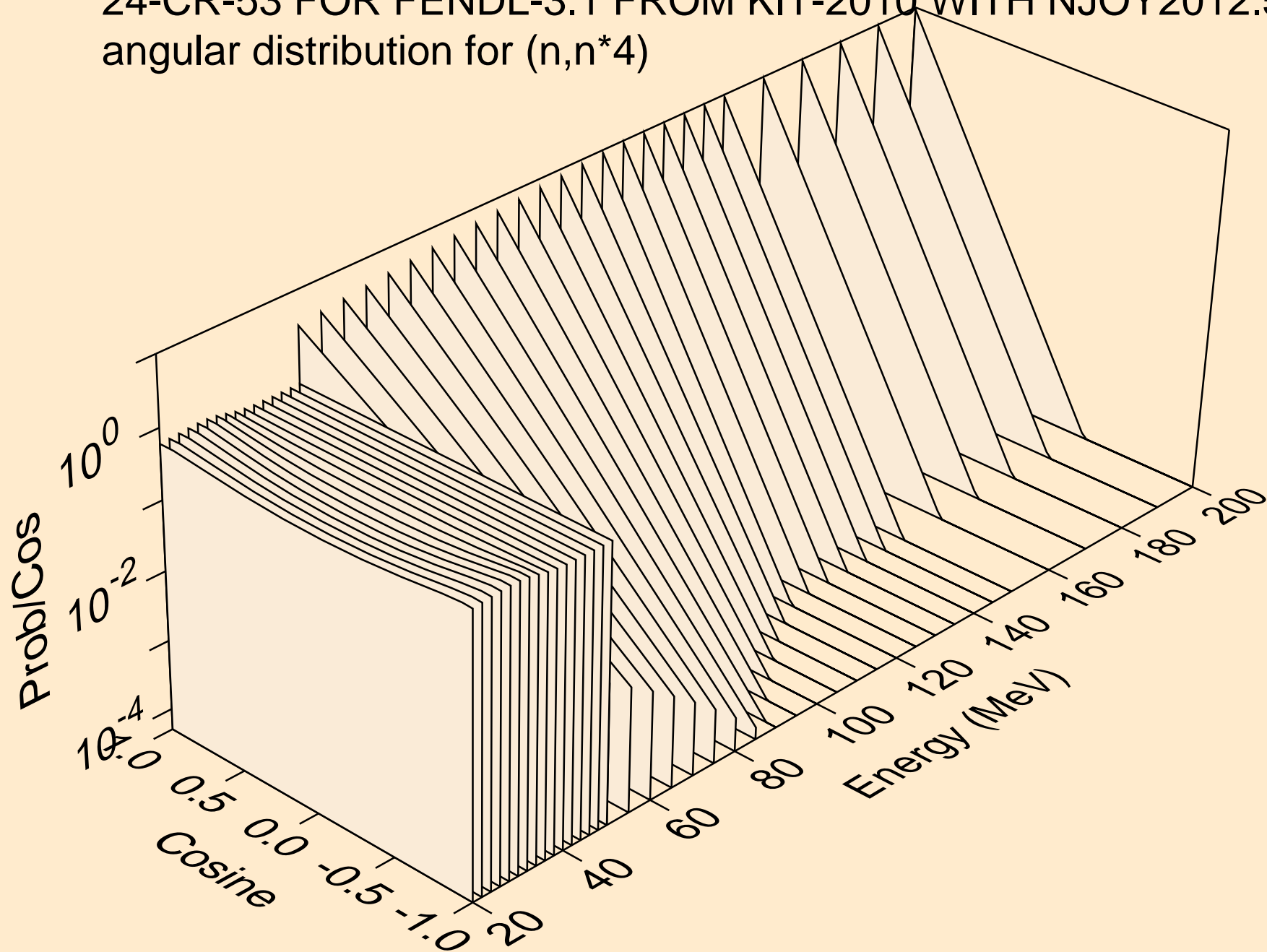

24-CR-53 FOR FENDL-3.1 FROM KIT-2010 WITH NJOY2012.50+ C
angular distribution for (n,n*5)

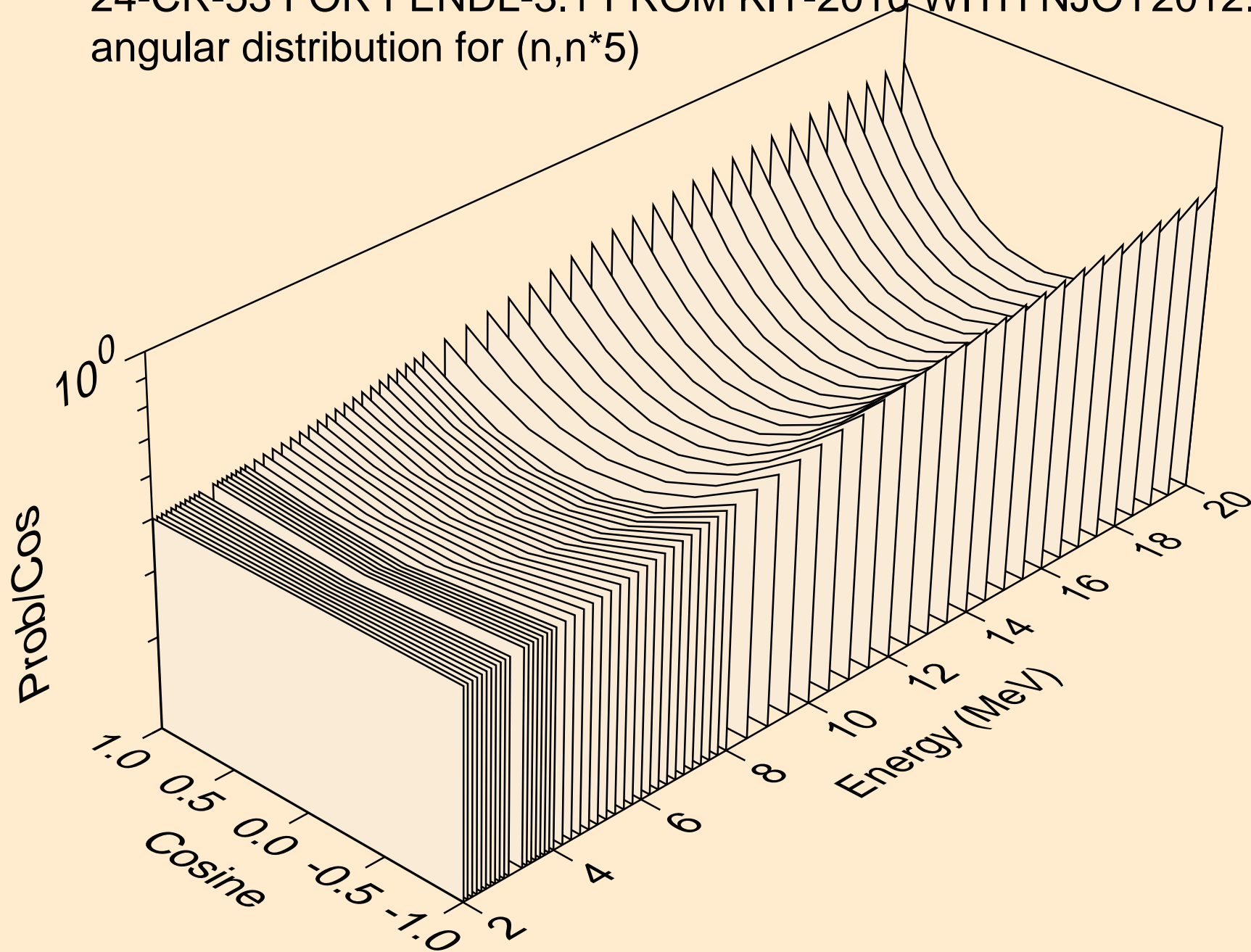

24-CR-53 FOR FENDL-3.1 FROM KIT-2010 WITH NJOY2012.50+ C
angular distribution for (n,n*5)

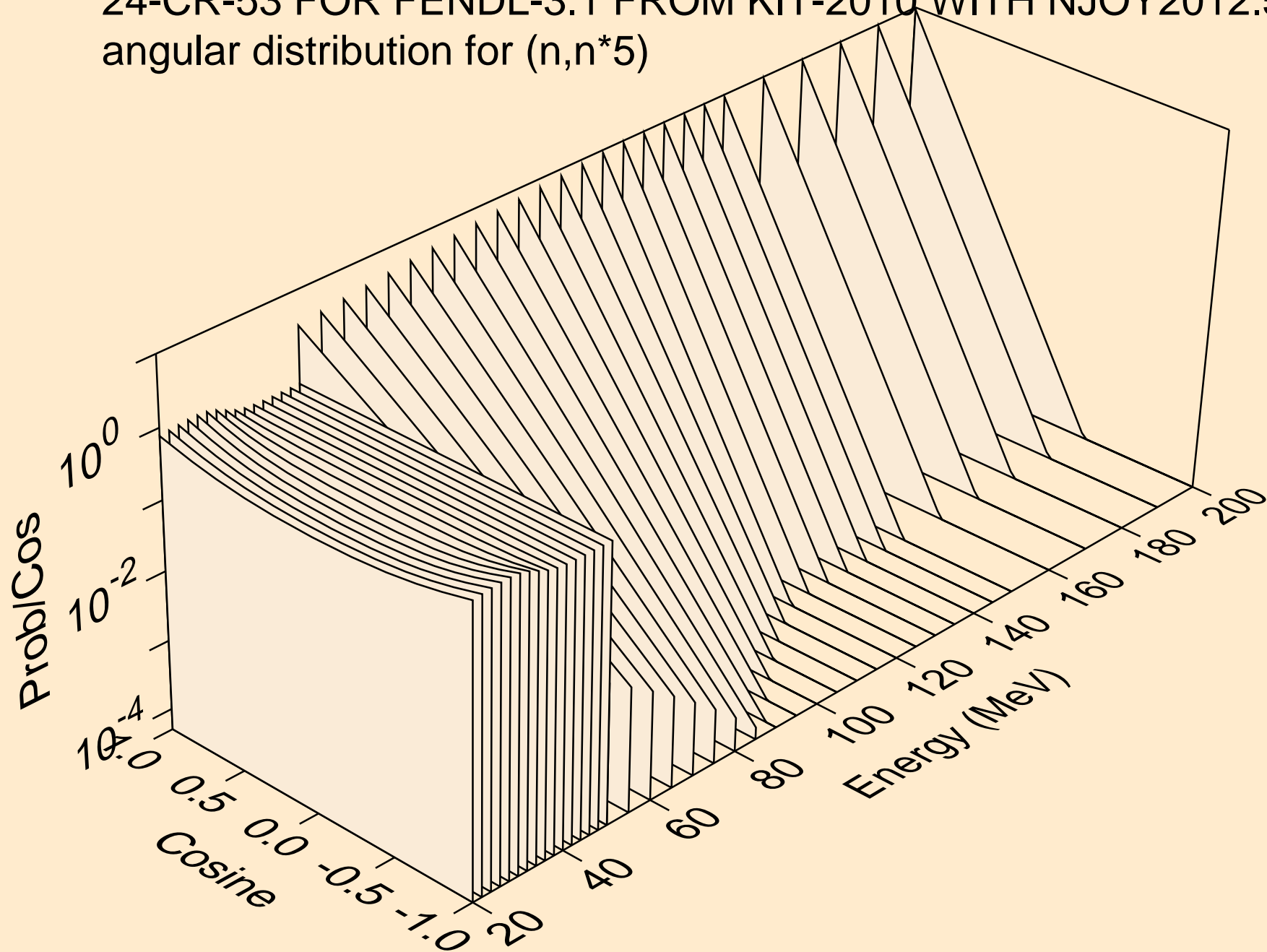

24-CR-53 FOR FENDL-3.1 FROM KIT-2010 WITH NJOY2012.50+ C
angular distribution for (n,n*6)

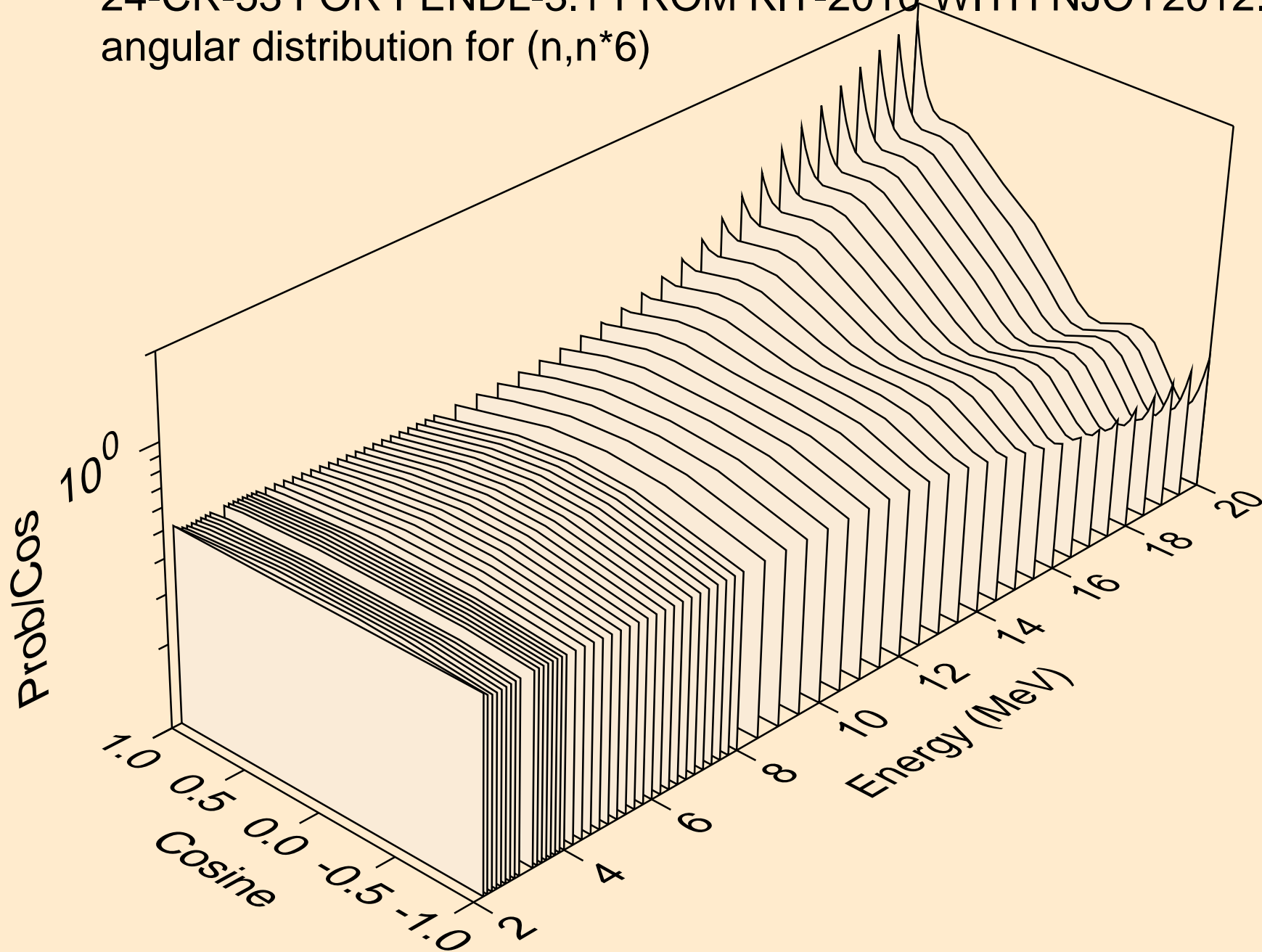

24-CR-53 FOR FENDL-3.1 FROM KIT-2010 WITH NJOY2012.50+ C
angular distribution for (n,n*6)

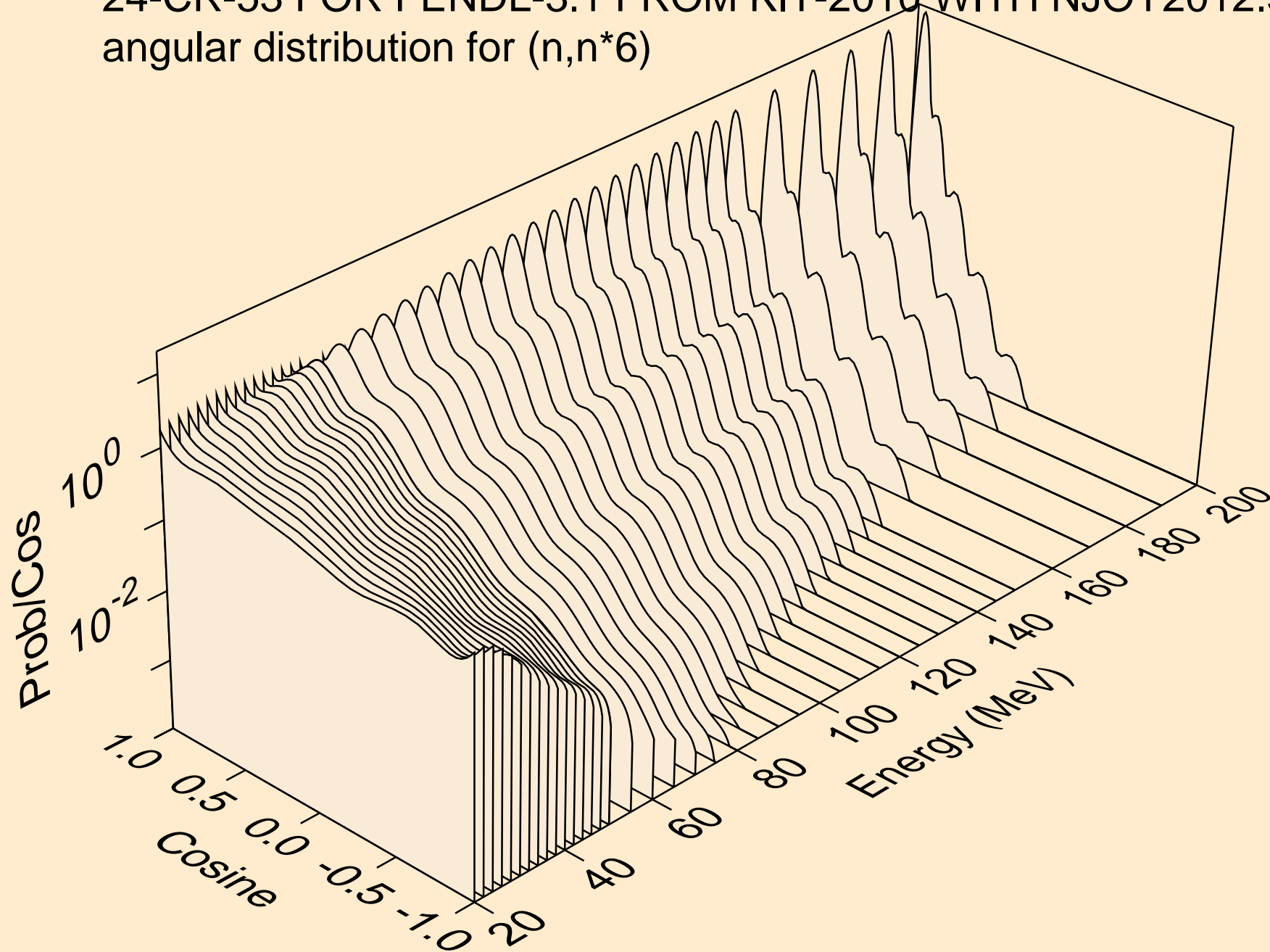

24-CR-53 FOR FENDL-3.1 FROM KIT-2010 WITH NJOY2012.50+ C
angular distribution for (n,n*7)

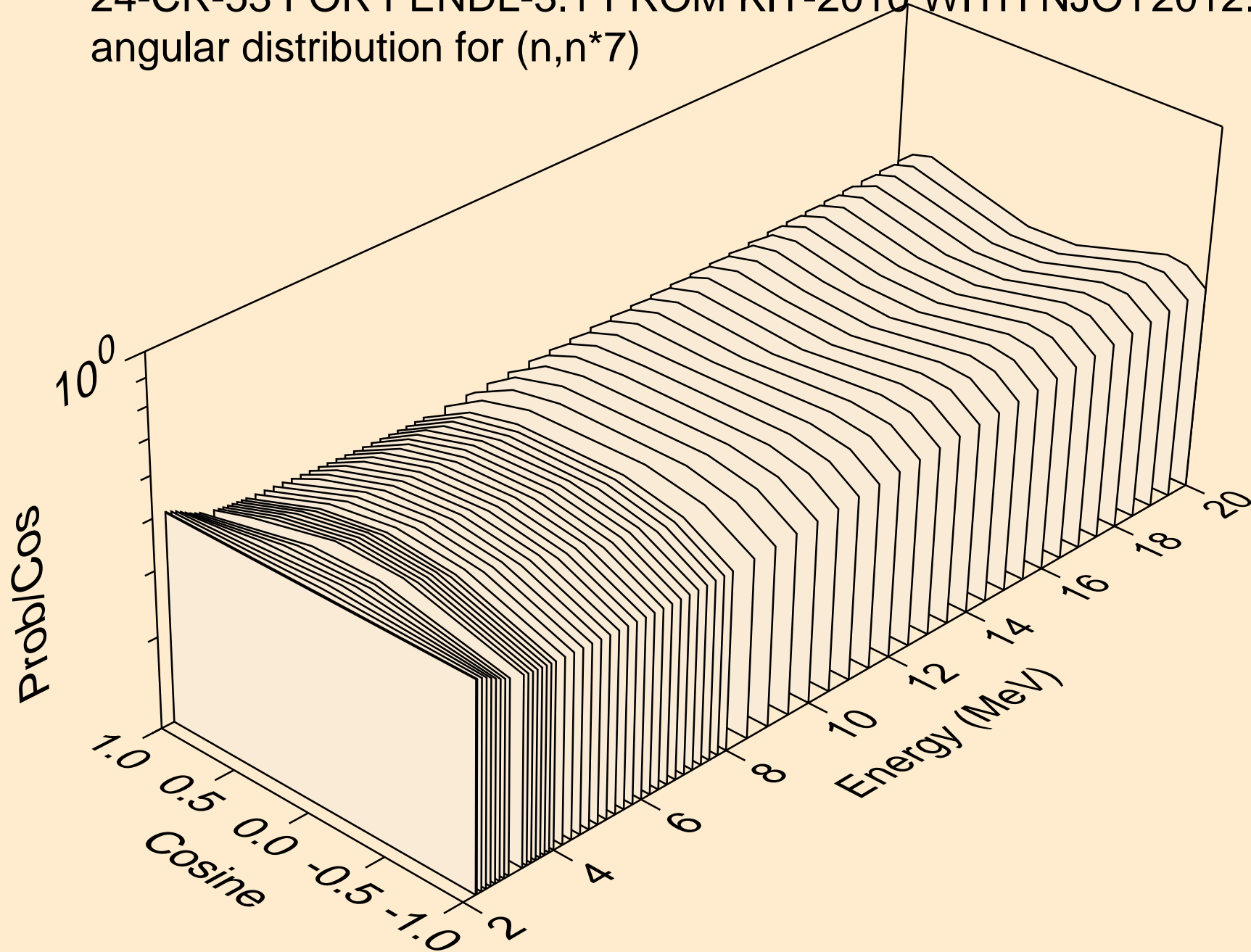

24-CR-53 FOR FENDL-3.1 FROM KIT-2010 WITH NJOY2012.50+ C
angular distribution for (n,n*7)

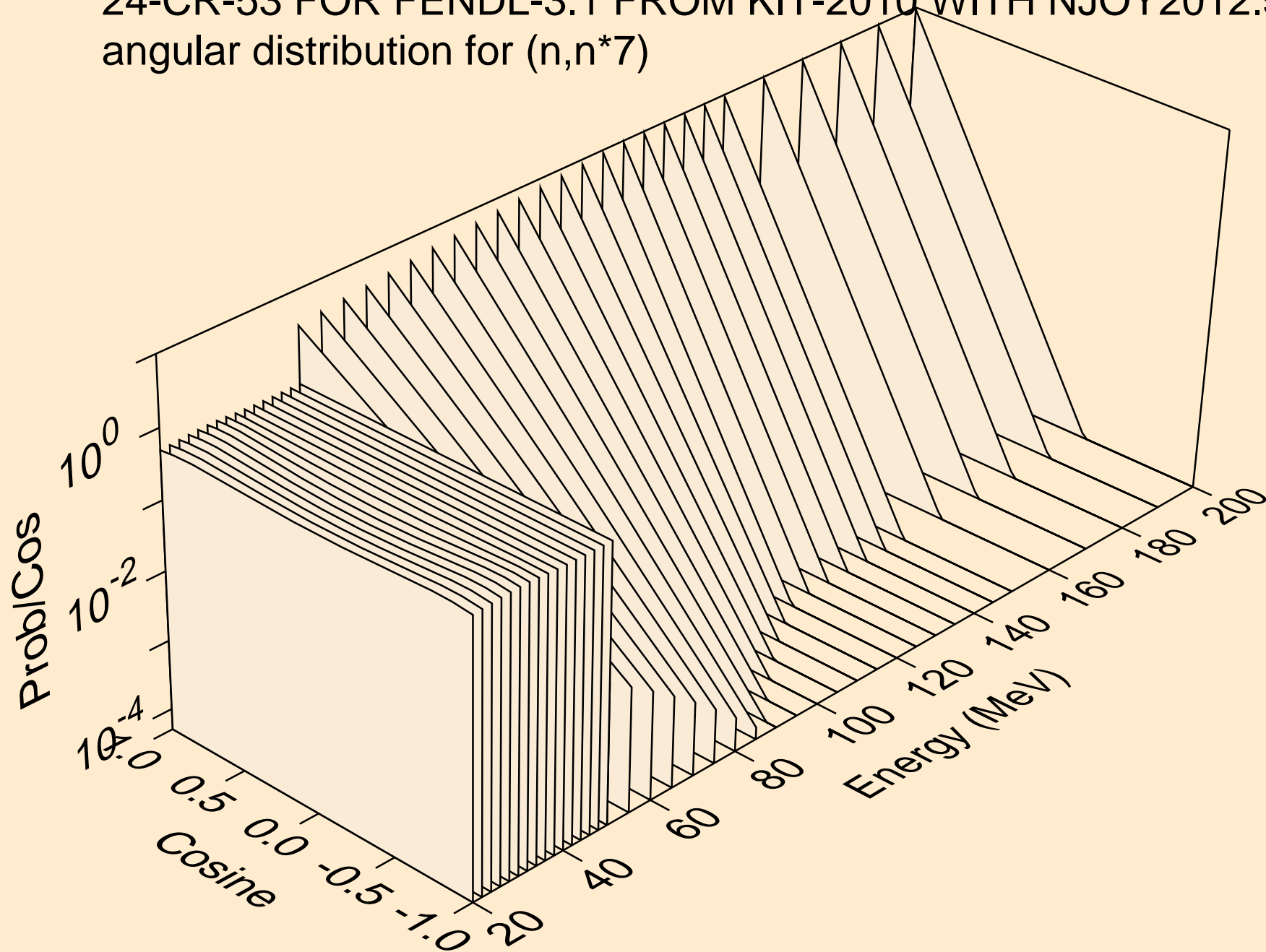

24-CR-53 FOR FENDL-3.1 FROM KIT-2010 WITH NJOY2012.50+ C
angular distribution for (n,n*8)

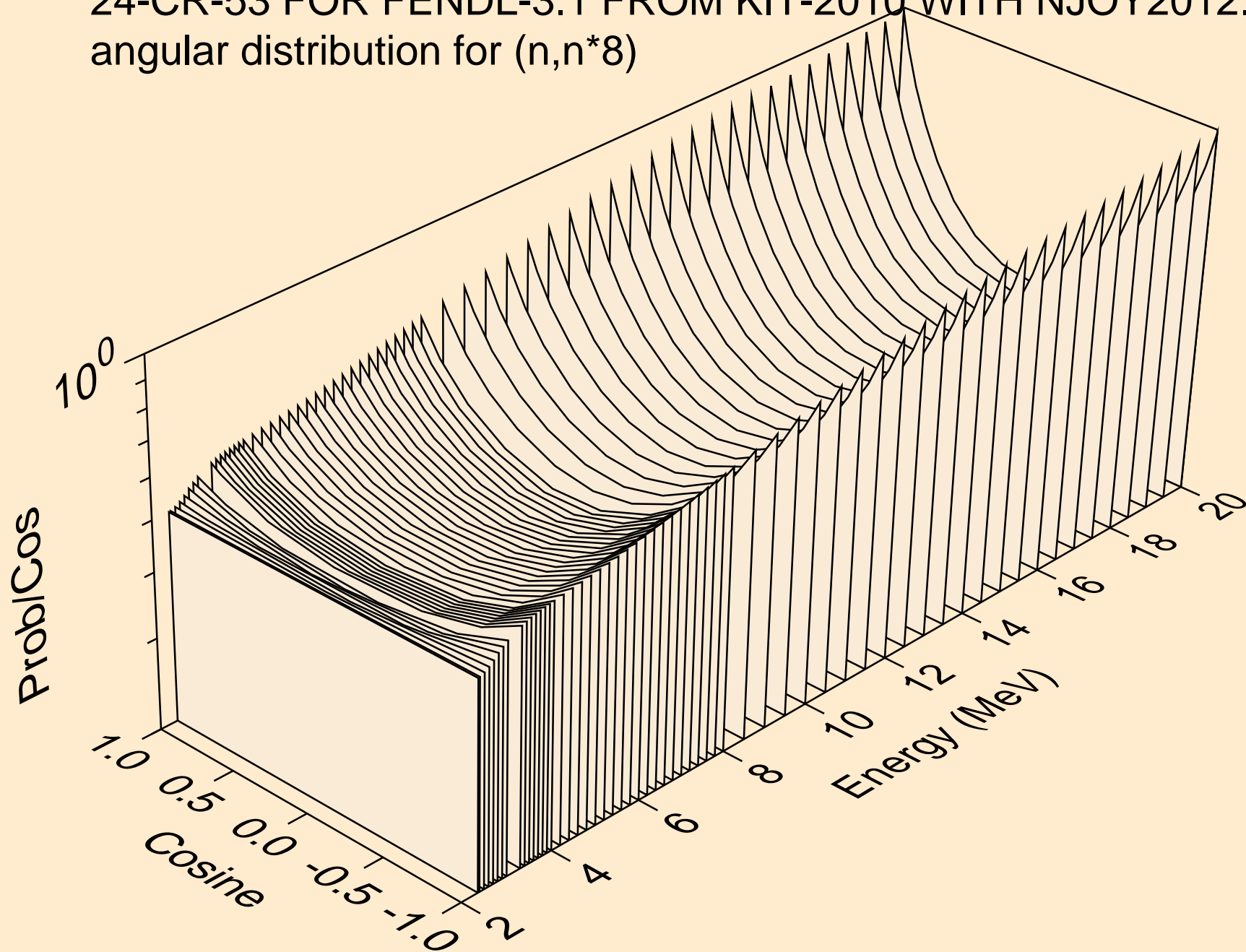

24-CR-53 FOR FENDL-3.1 FROM KIT-2010 WITH NJOY2012.50+ C
angular distribution for (n,n*8)

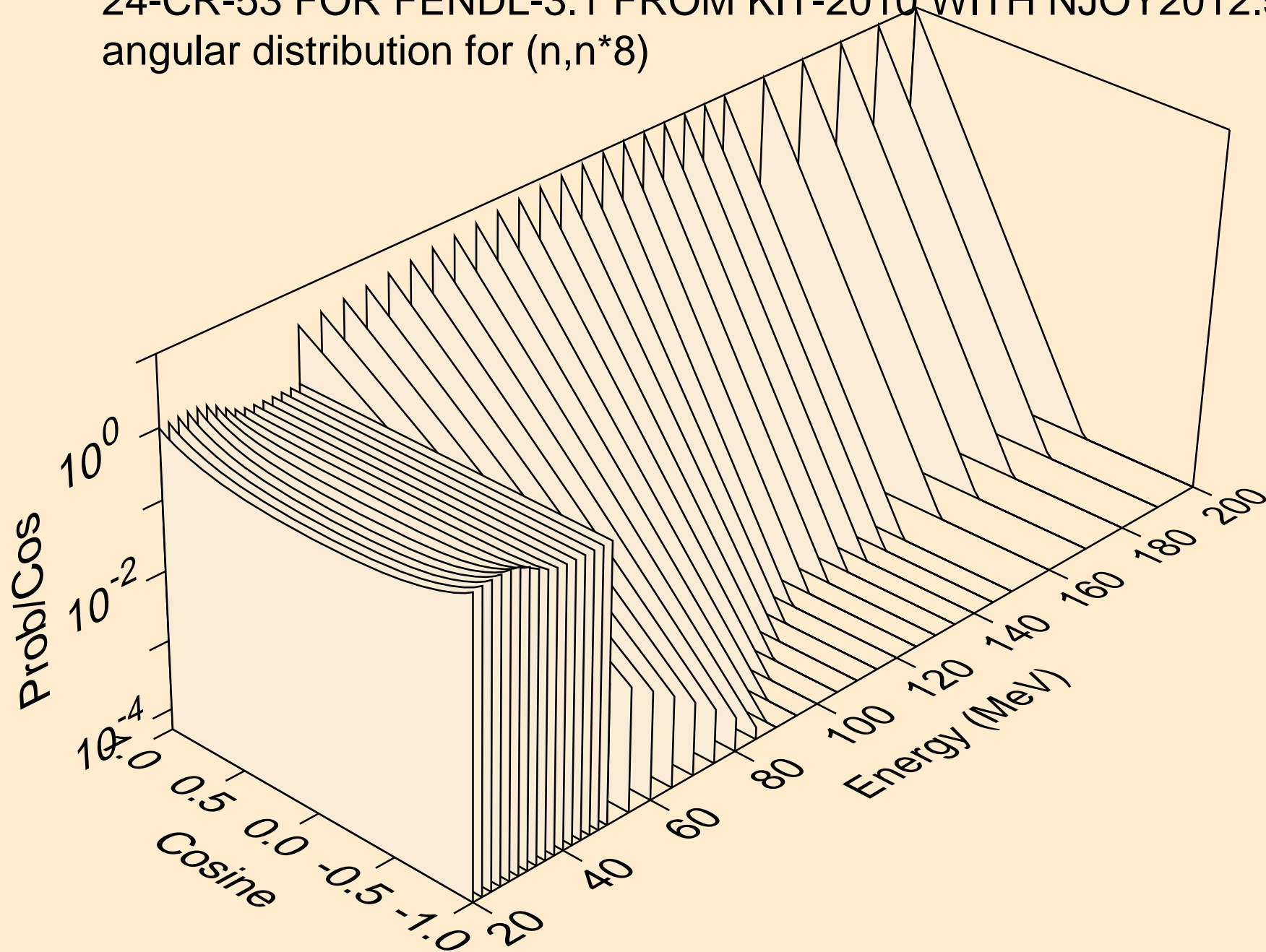

24-CR-53 FOR FENDL-3.1 FROM KIT-2010 WITH NJOY2012.50+ C
angular distribution for (n,n*9)

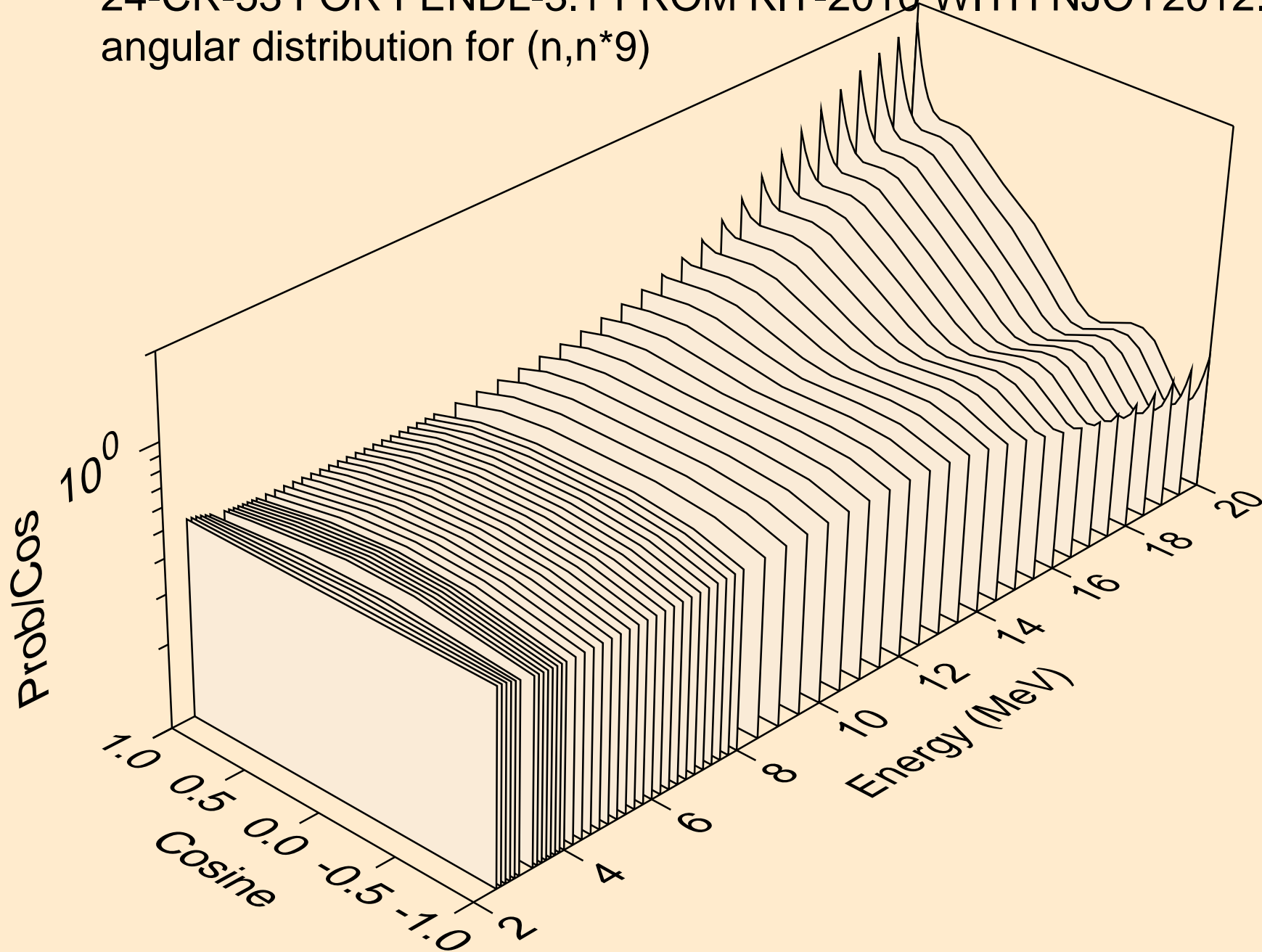

24-CR-53 FOR FENDL-3.1 FROM KIT-2010 WITH NJOY2012.50+ C
angular distribution for (n,n*9)

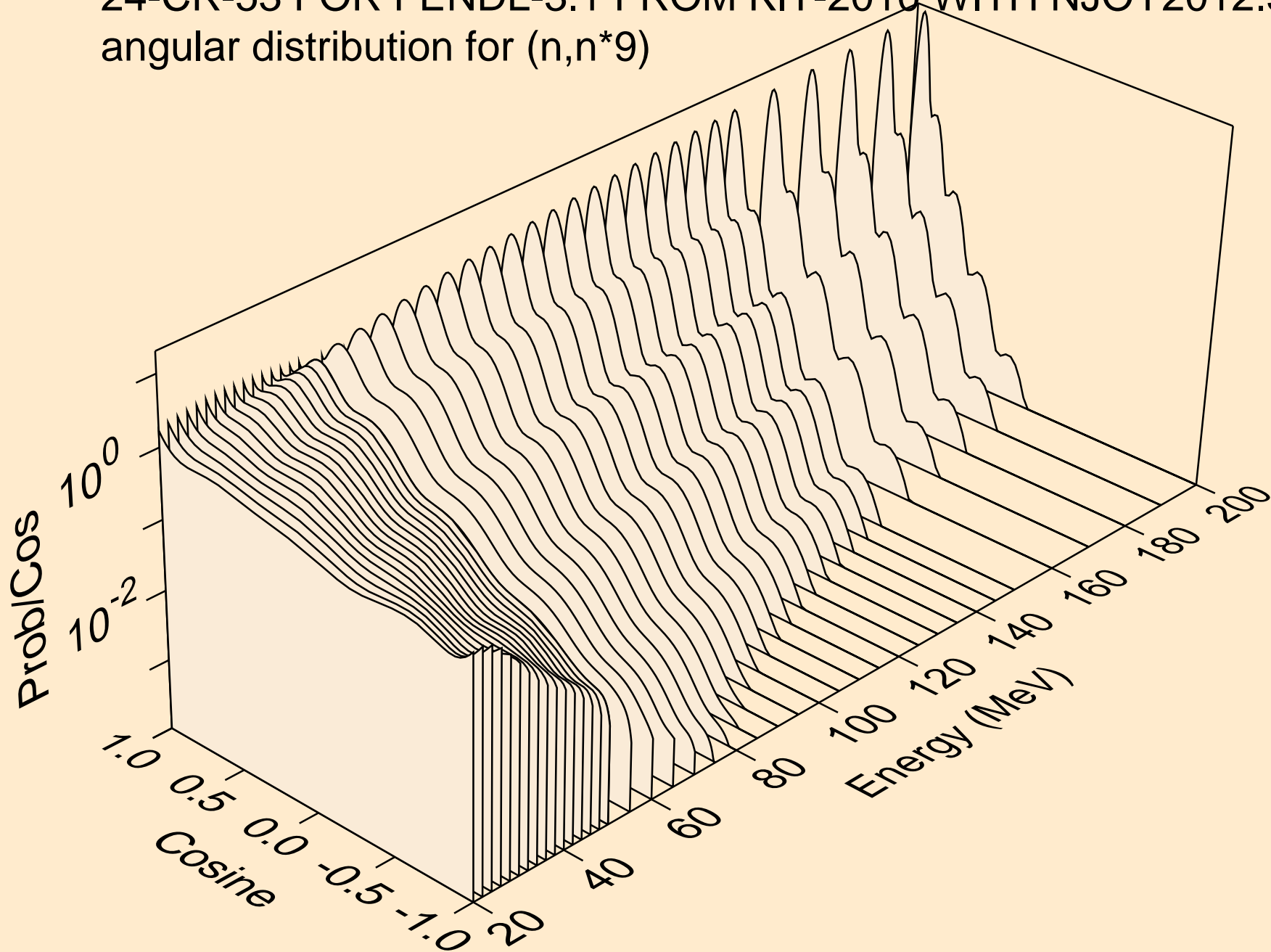

24-CR-53 FOR FENDL-3.1 FROM KIT-2010 WITH NJOY2012.50+ C
angular distribution for (n,n*10)

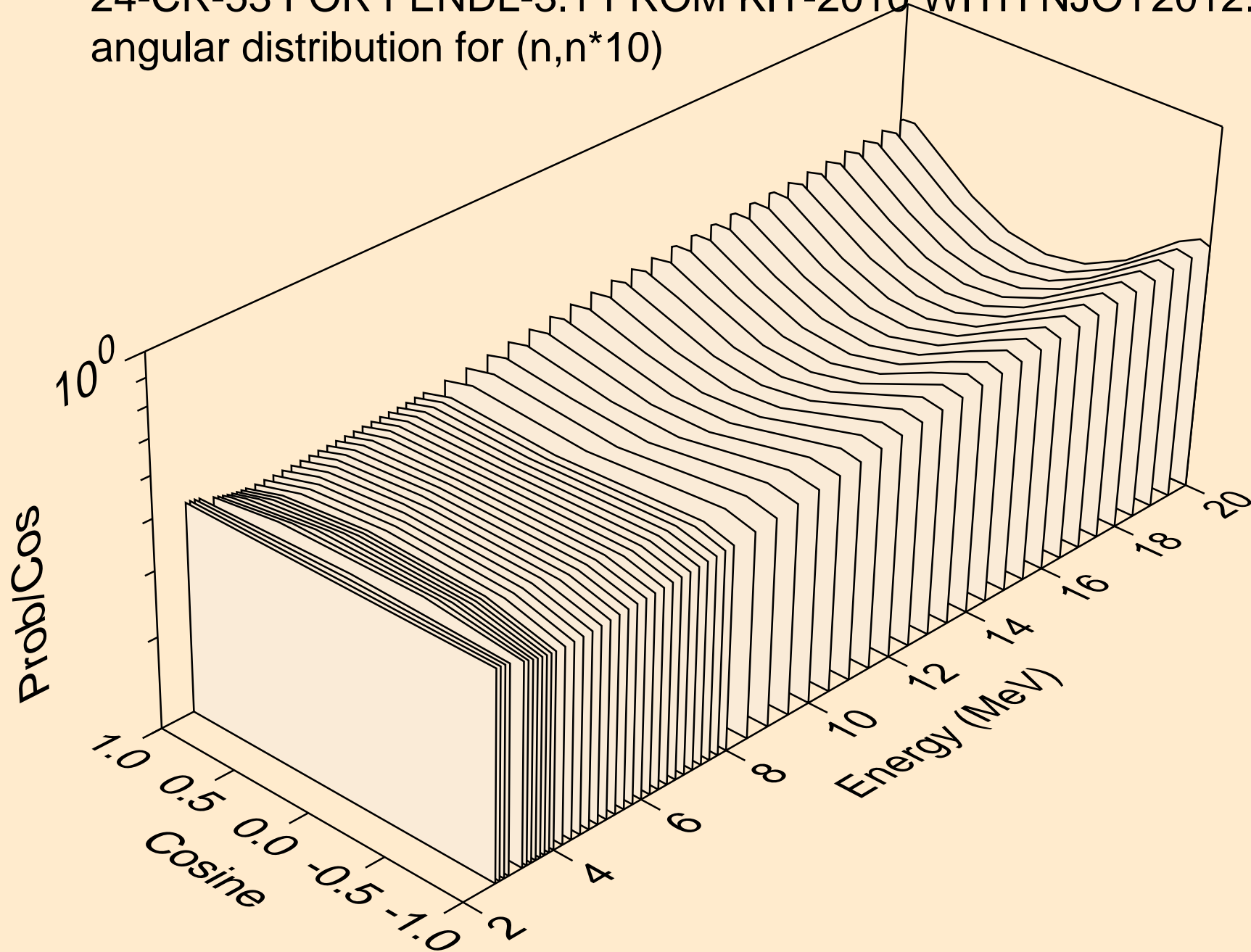

24-CR-53 FOR FENDL-3.1 FROM KIT-2010 WITH NJOY2012.50+ C
angular distribution for (n,n*10)

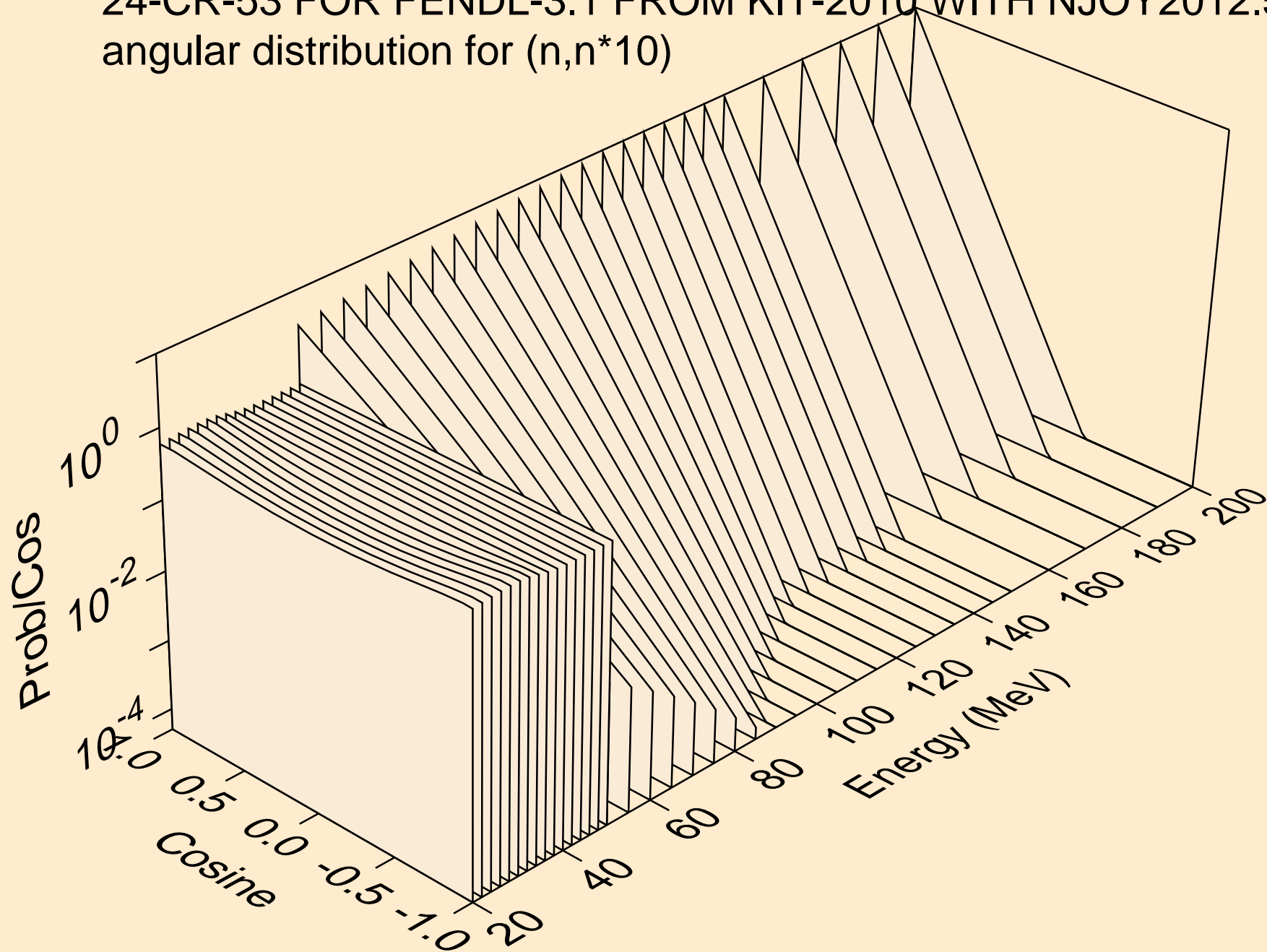

24-CR-53 FOR FENDL-3.1 FROM KIT-2010 WITH NJOY2012.50+ C
angular distribution for (n,n*11)

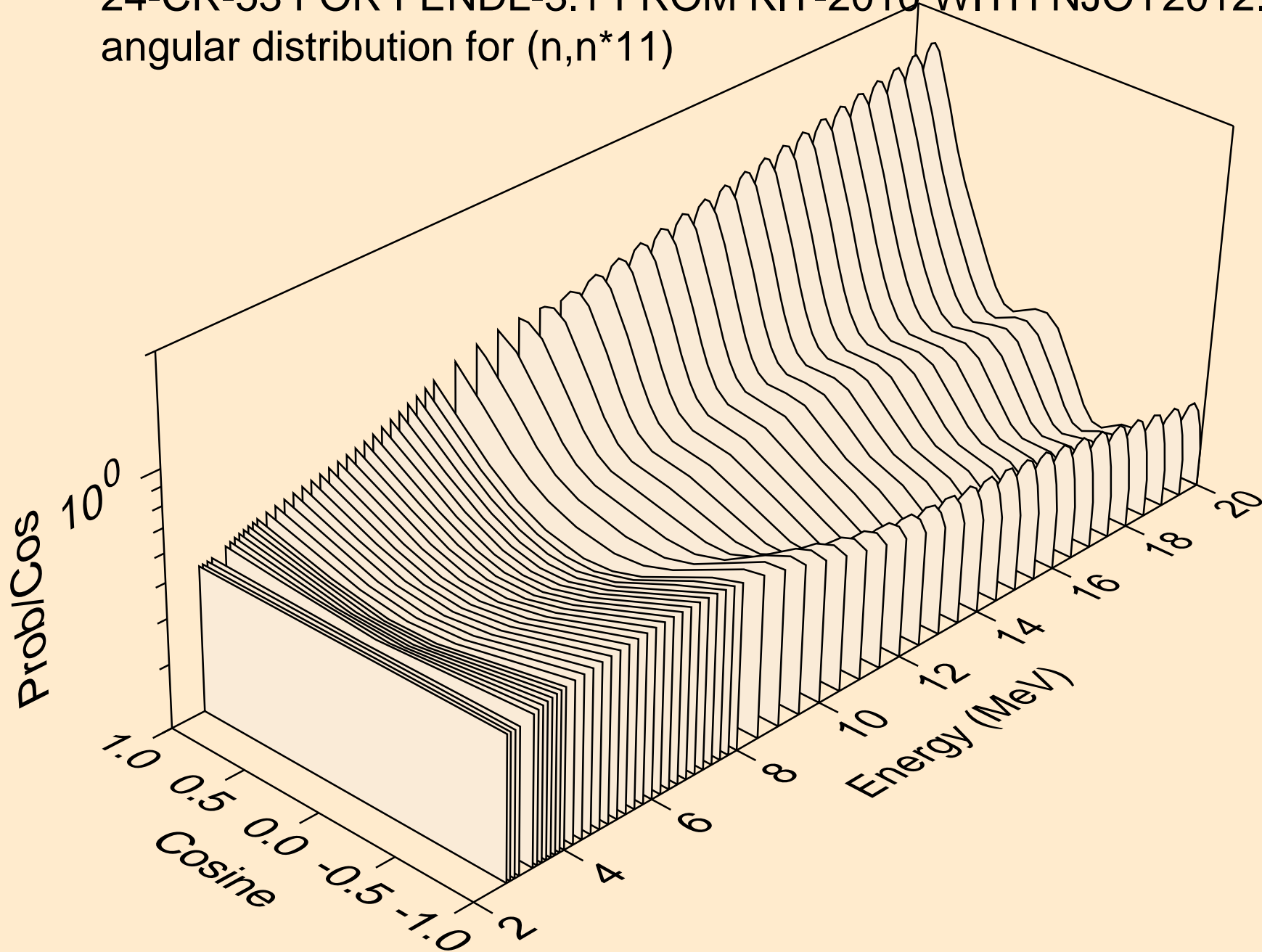

24-CR-53 FOR FENDL-3.1 FROM KIT-2010 WITH NJOY2012.50+ C
angular distribution for (n,n*11)

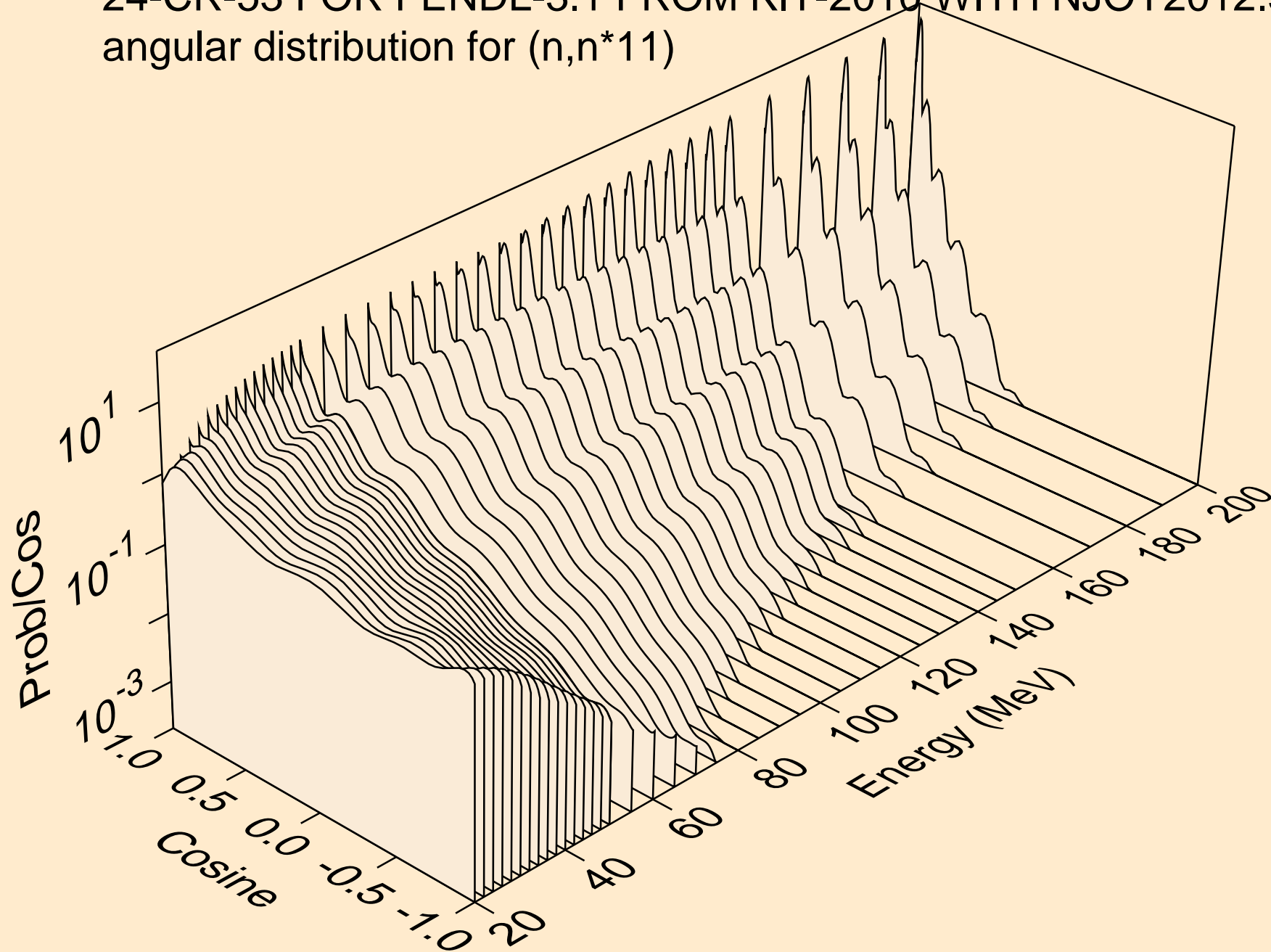

24-CR-53 FOR FENDL-3.1 FROM KIT-2010 WITH NJOY2012.50+ C
angular distribution for (n,n*12)

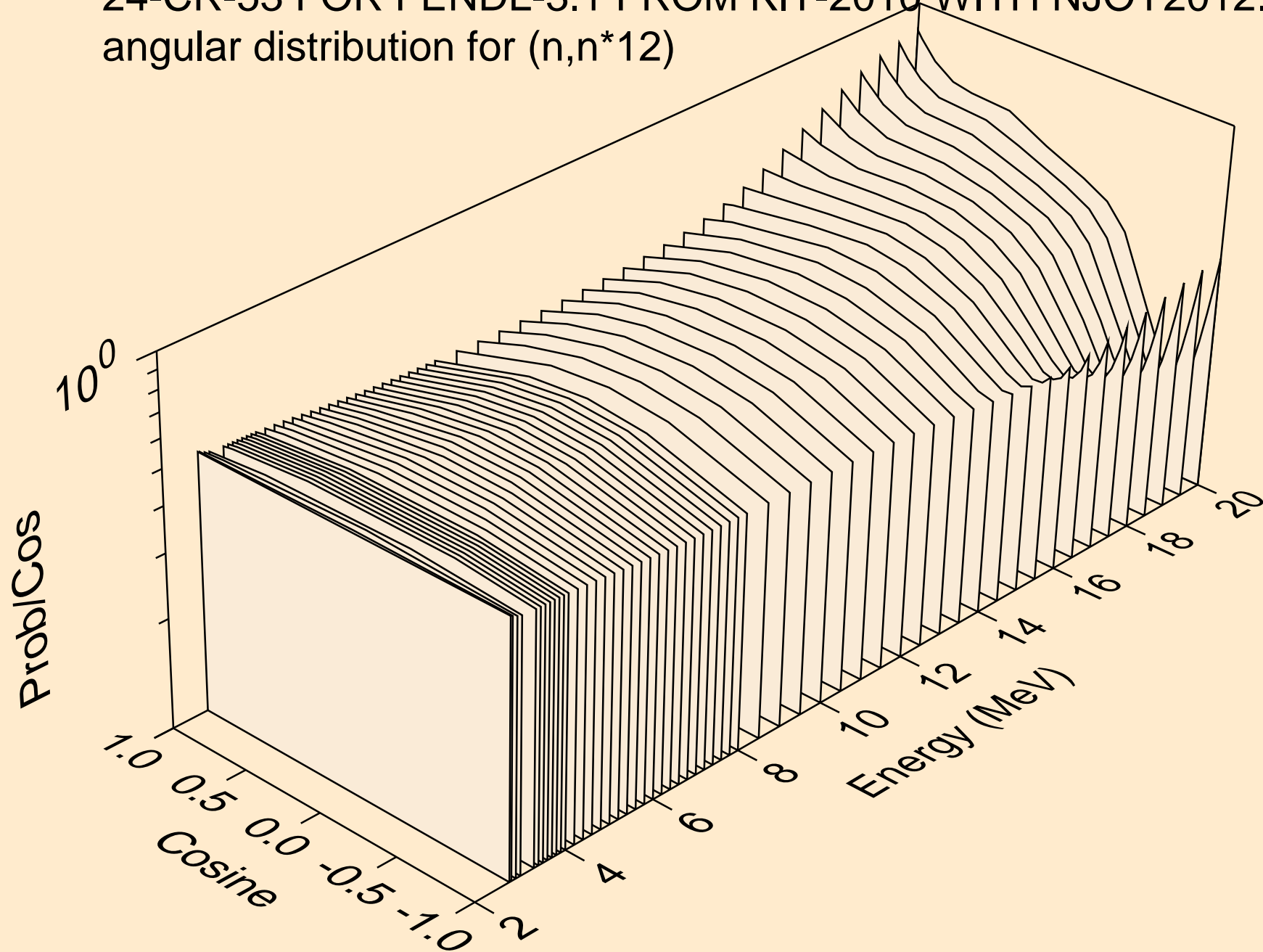

24-CR-53 FOR FENDL-3.1 FROM KIT-2010 WITH NJOY2012.50+ C
angular distribution for (n,n*12)

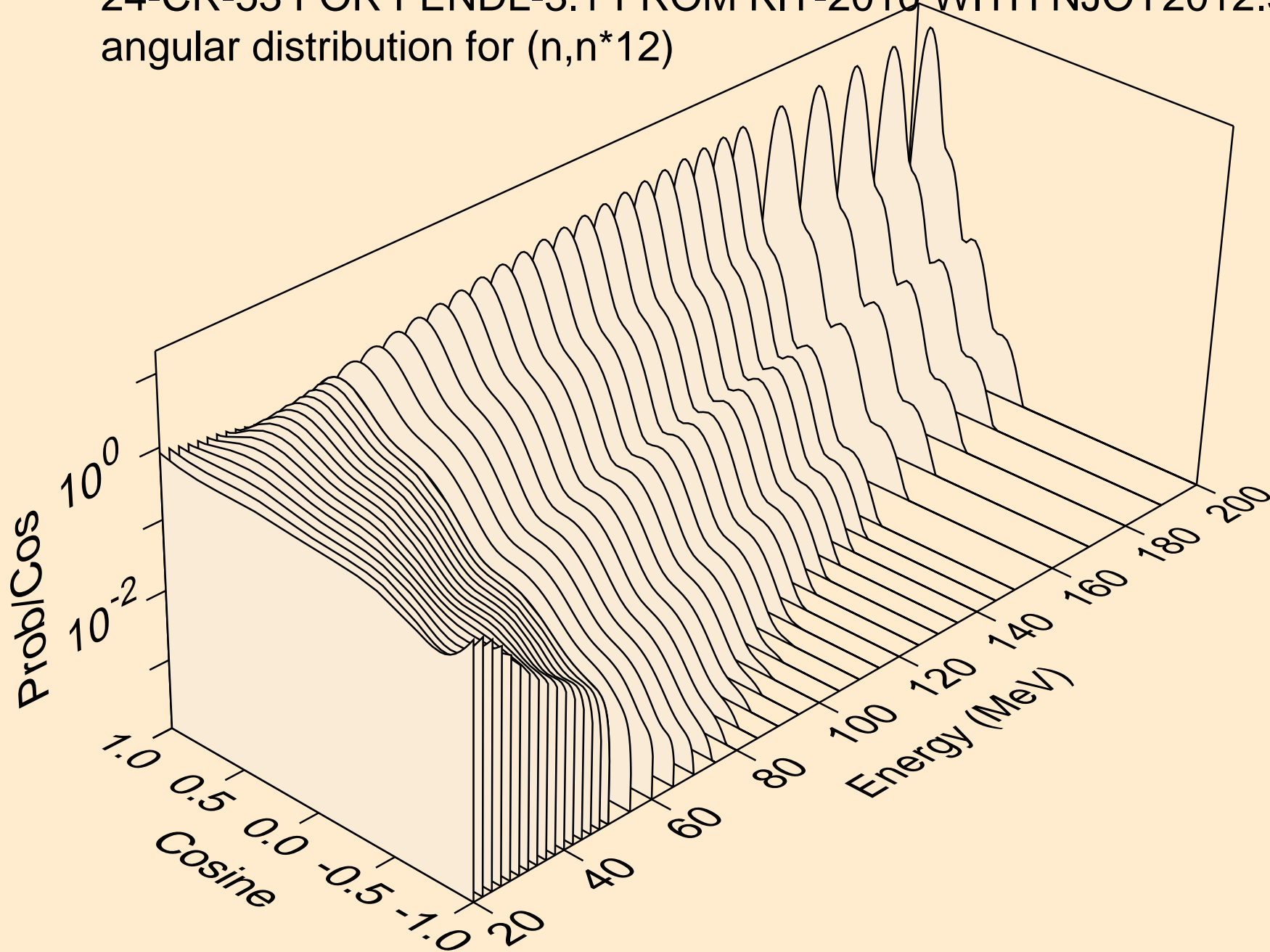

24-CR-53 FOR FENDL-3.1 FROM KIT-2010 WITH NJOY2012.50+ C
angular distribution for (n,n*13)

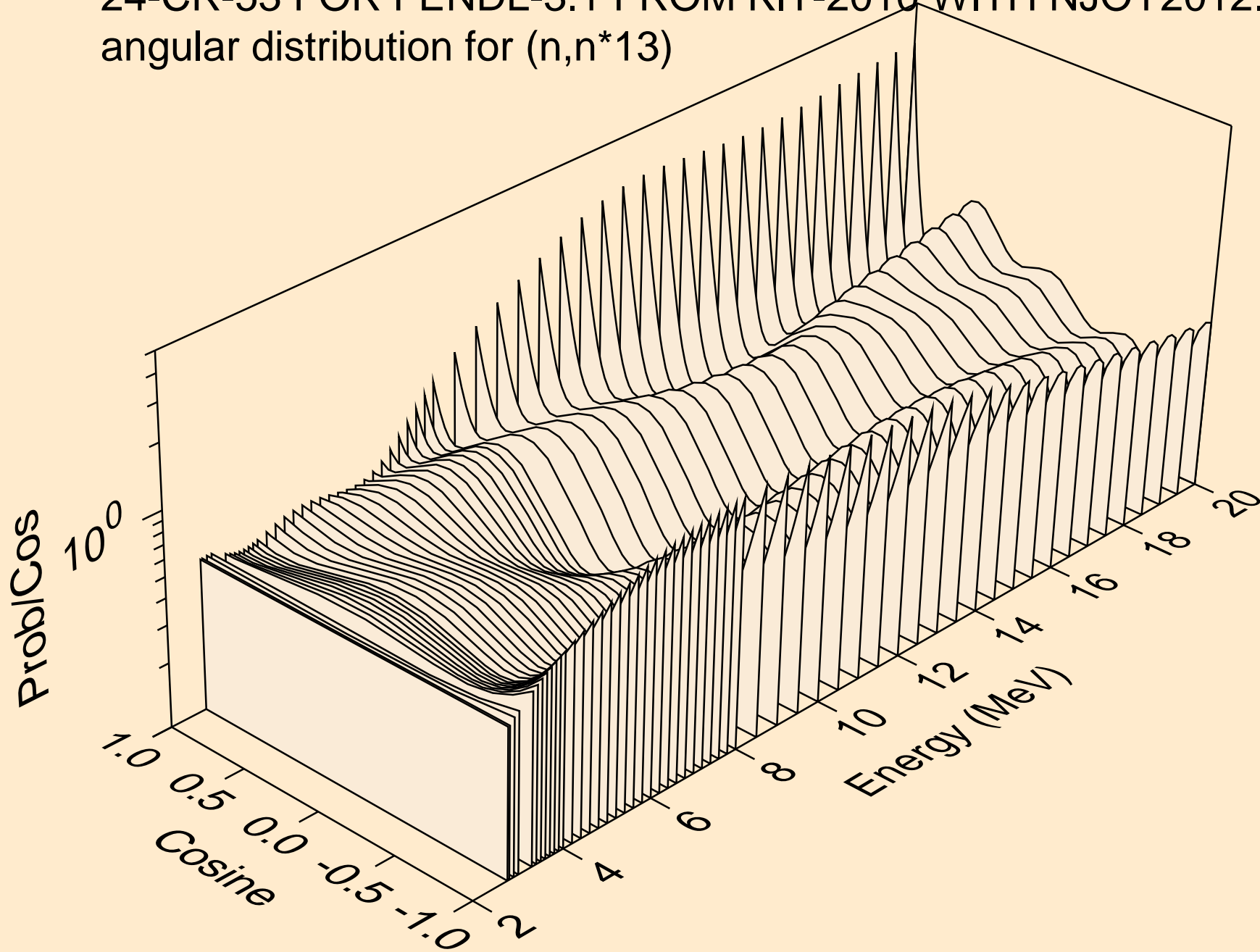

24-CR-53 FOR FENDL-3.1 FROM KIT-2010 WITH NJOY2012.50+ C
angular distribution for (n,n*13)

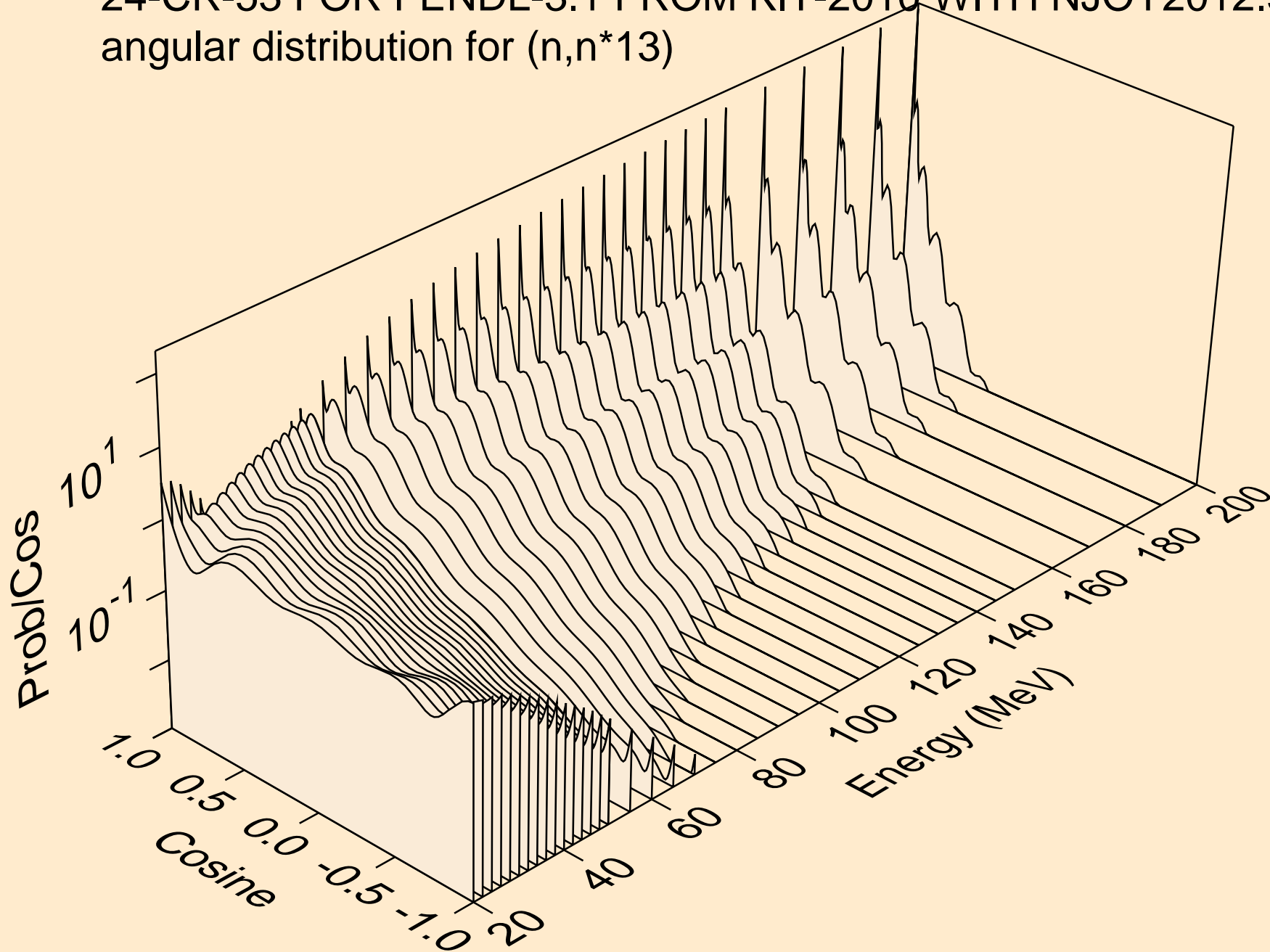

24-CR-53 FOR FENDL-3.1 FROM KIT-2010 WITH NJOY2012.50+ C
angular distribution for (n,n*14)

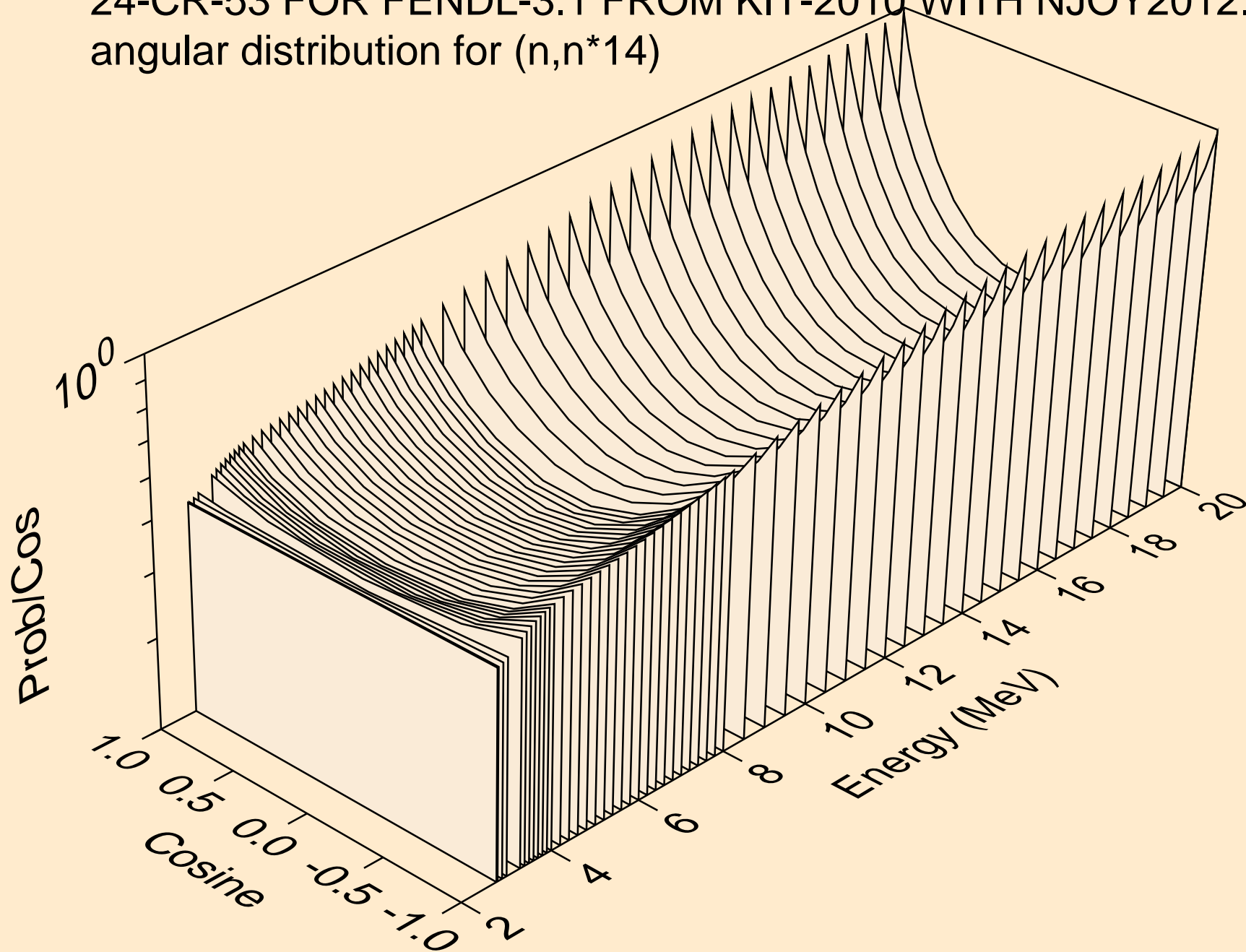

24-CR-53 FOR FENDL-3.1 FROM KIT-2010 WITH NJOY2012.50+ C
angular distribution for (n,n*14)

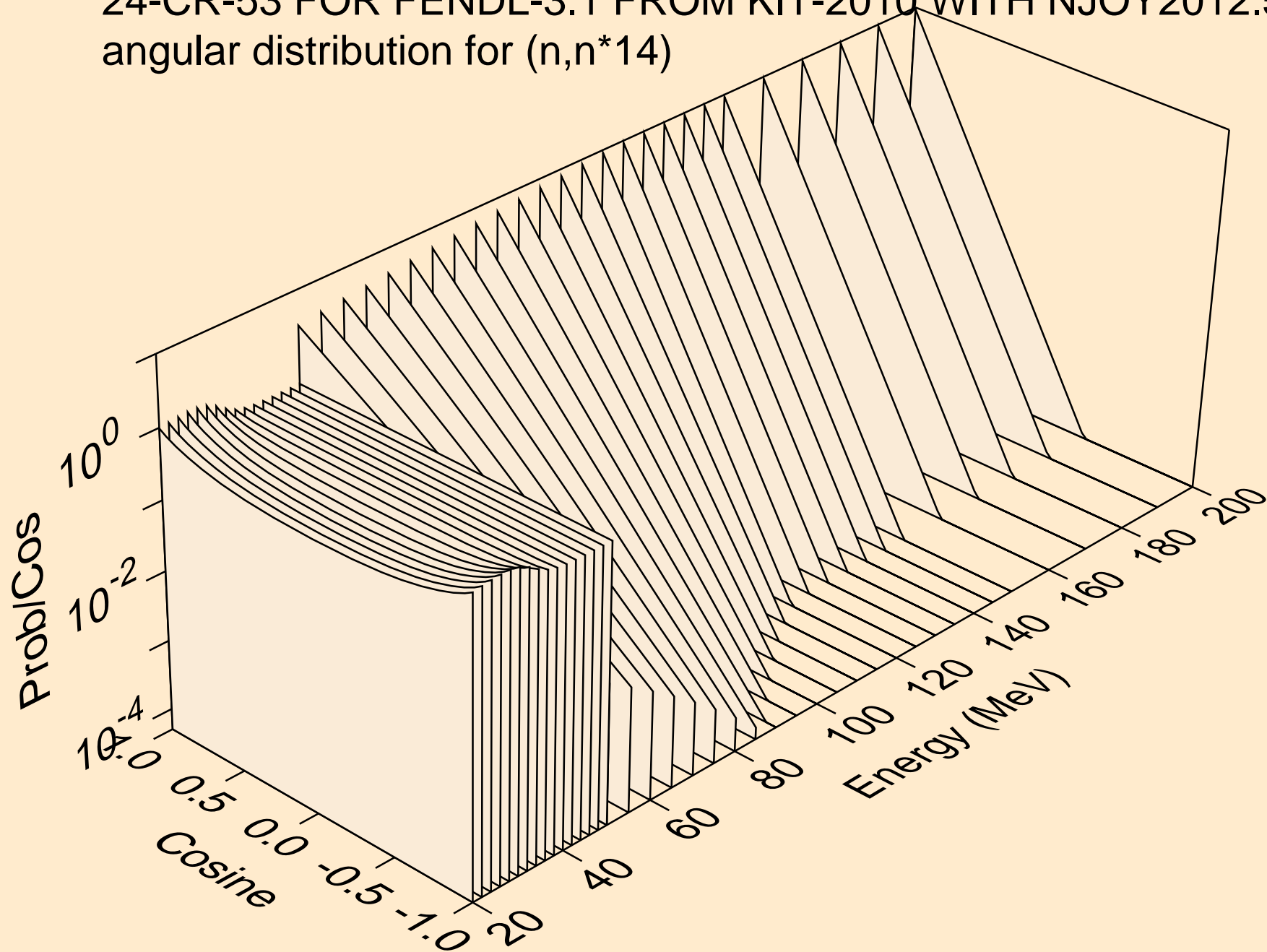

24-CR-53 FOR FENDL-3.1 FROM KIT-2010 WITH NJOY2012.50+ C
angular distribution for (n,n*15)

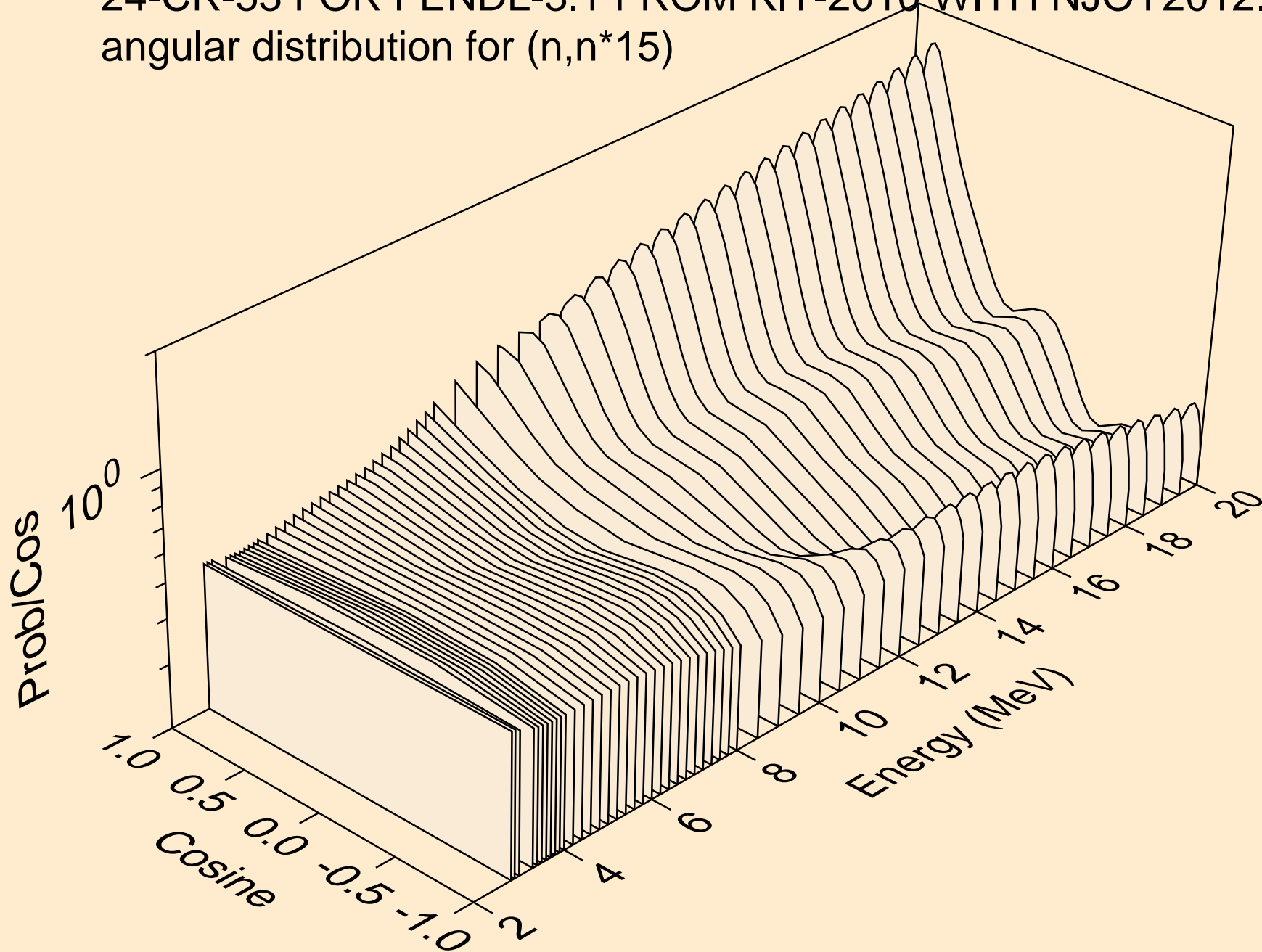

24-CR-53 FOR FENDL-3.1 FROM KIT-2010 WITH NJOY2012.50+ C
angular distribution for (n,n*15)

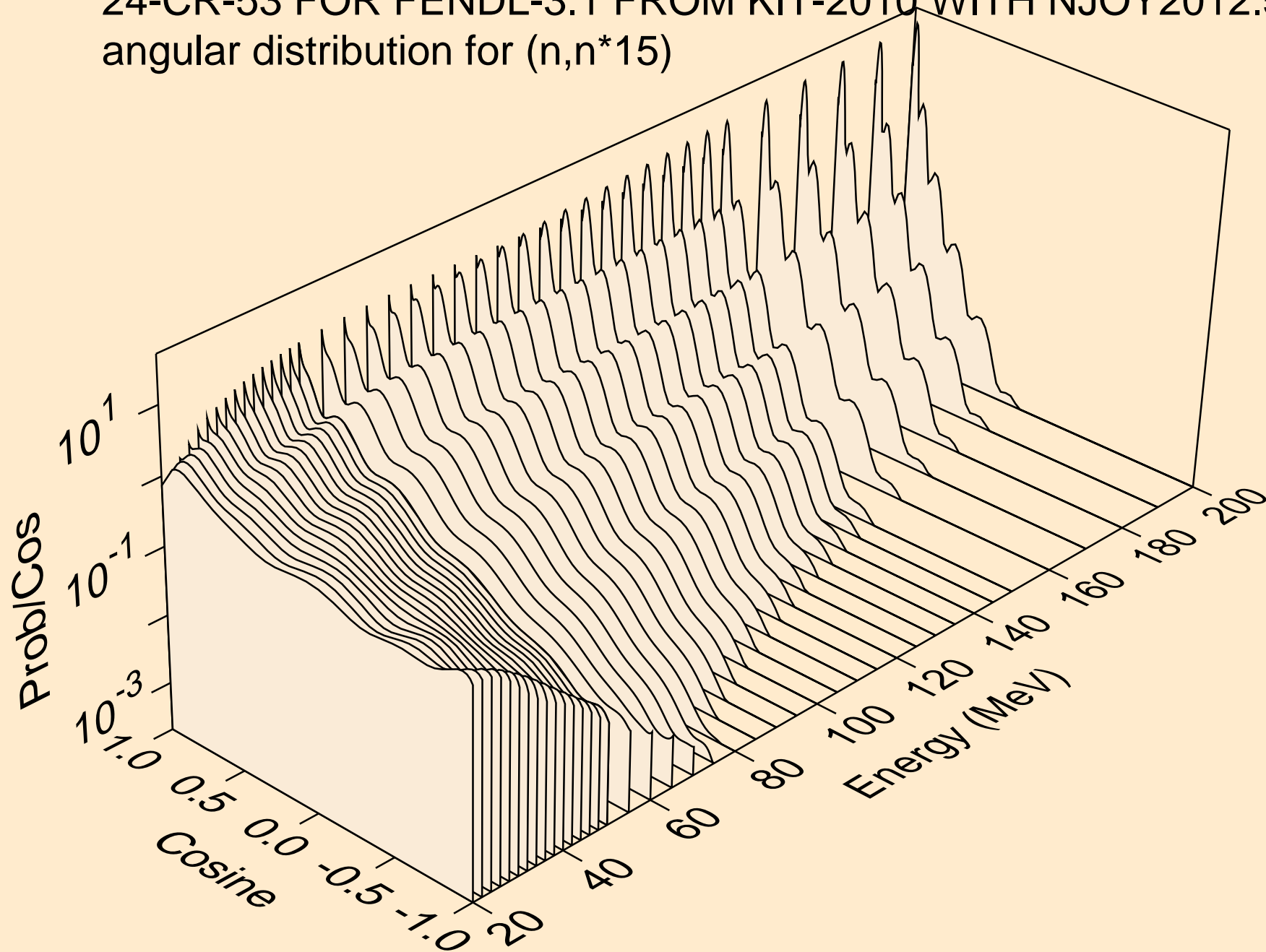

24-CR-53 FOR FENDL-3.1 FROM KIT-2010 WITH NJOY2012.50+ C
angular distribution for (n,n*16)

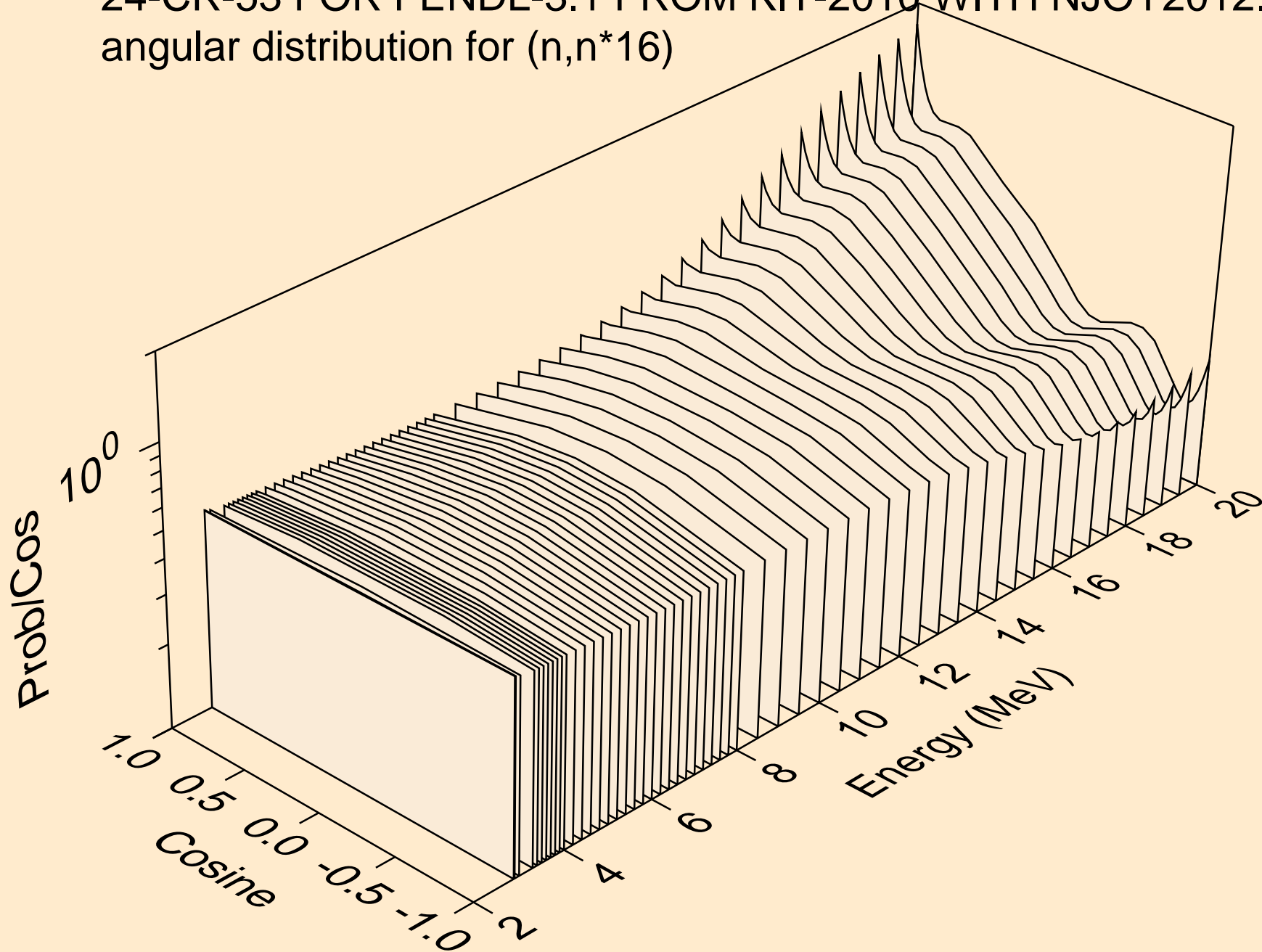

24-CR-53 FOR FENDL-3.1 FROM KIT-2010 WITH NJOY2012.50+ C
angular distribution for (n,n*16)

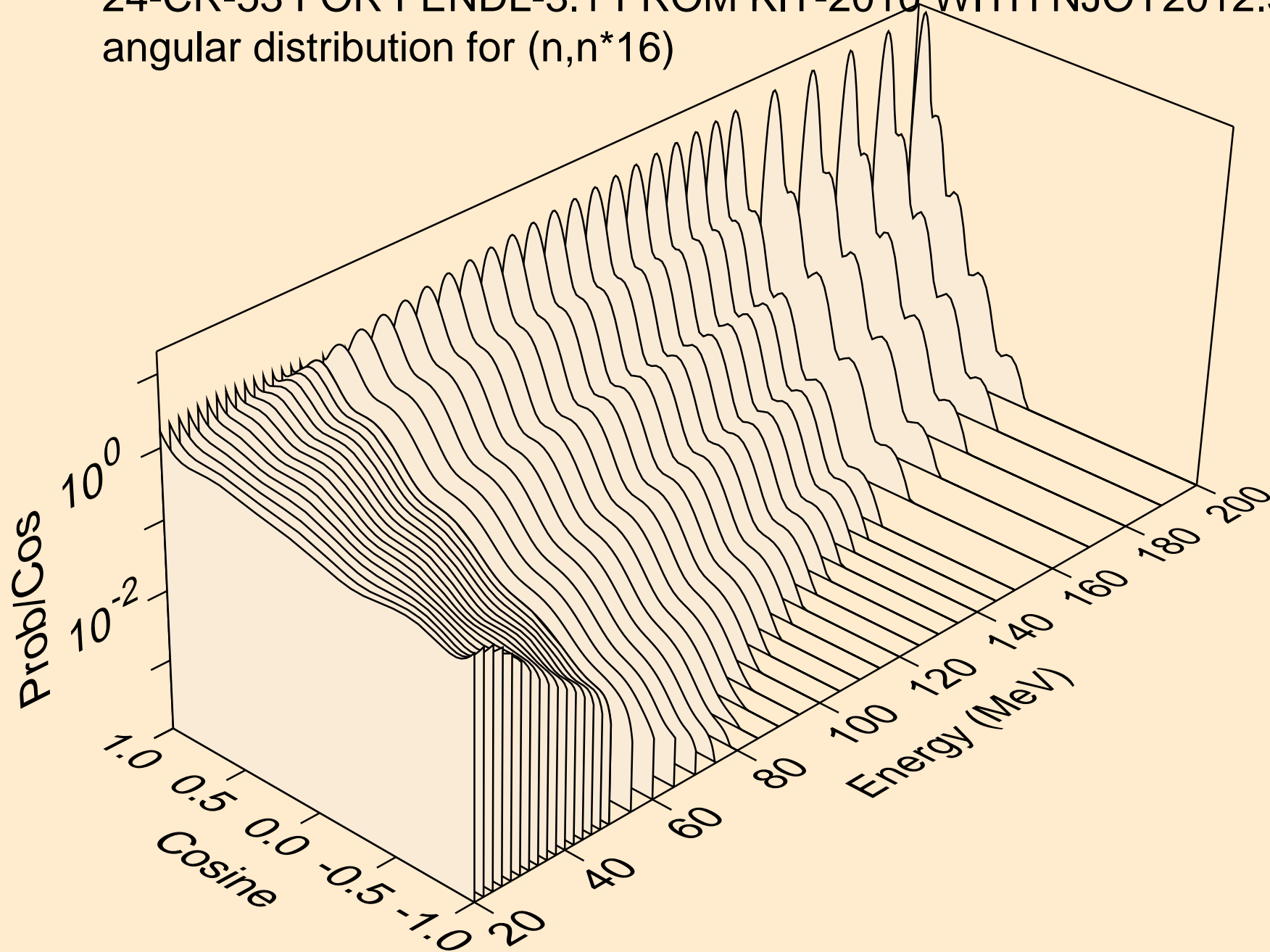

24-CR-53 FOR FENDL-3.1 FROM KIT-2010 WITH NJOY2012.50+ C
angular distribution for (n,n*17)

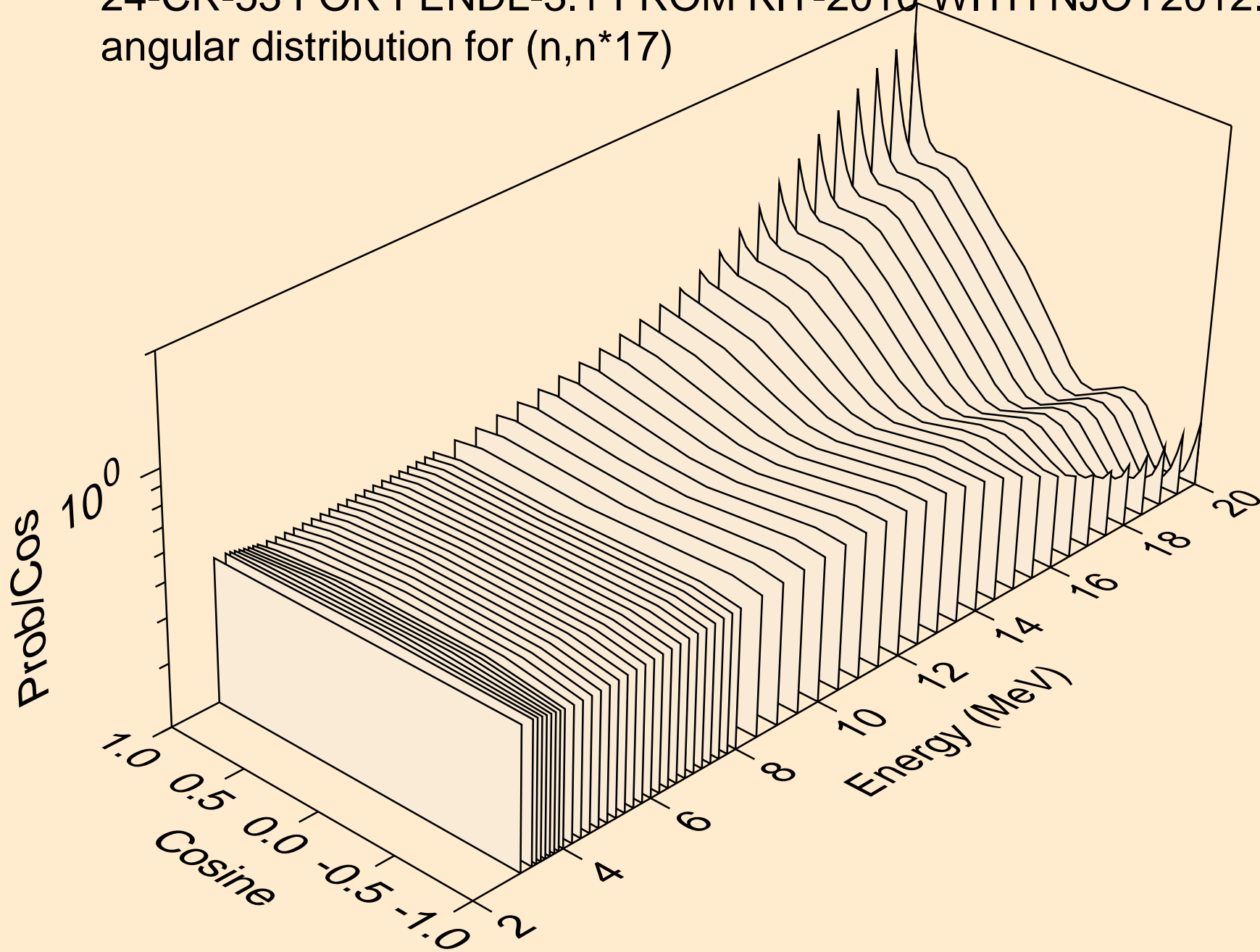

24-CR-53 FOR FENDL-3.1 FROM KIT-2010 WITH NJOY2012.50+ C
angular distribution for (n,n*17)

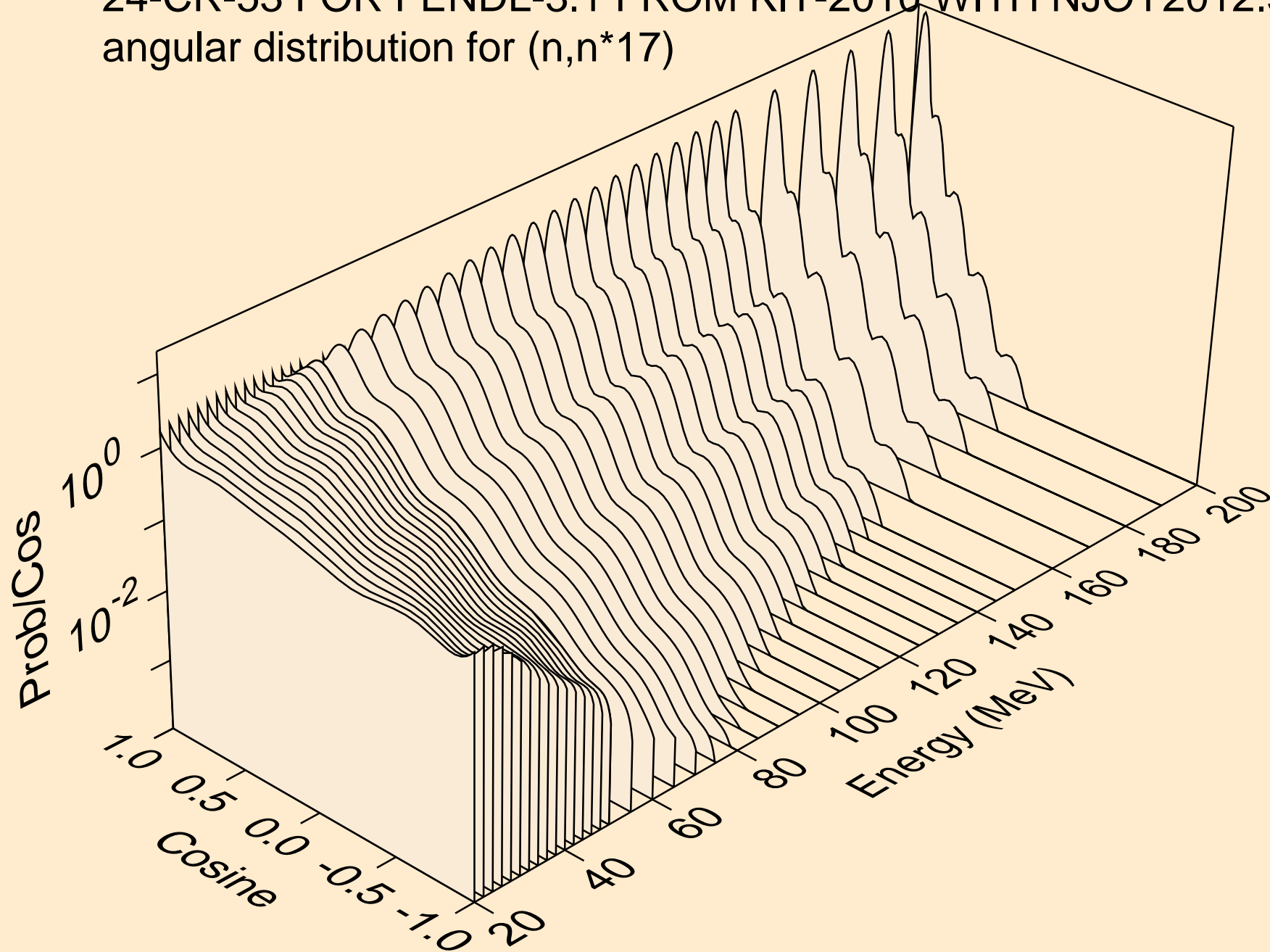

24-CR-53 FOR FENDL-3.1 FROM KIT-2010 WITH NJOY2012.50+ C
angular distribution for (n,n*18)

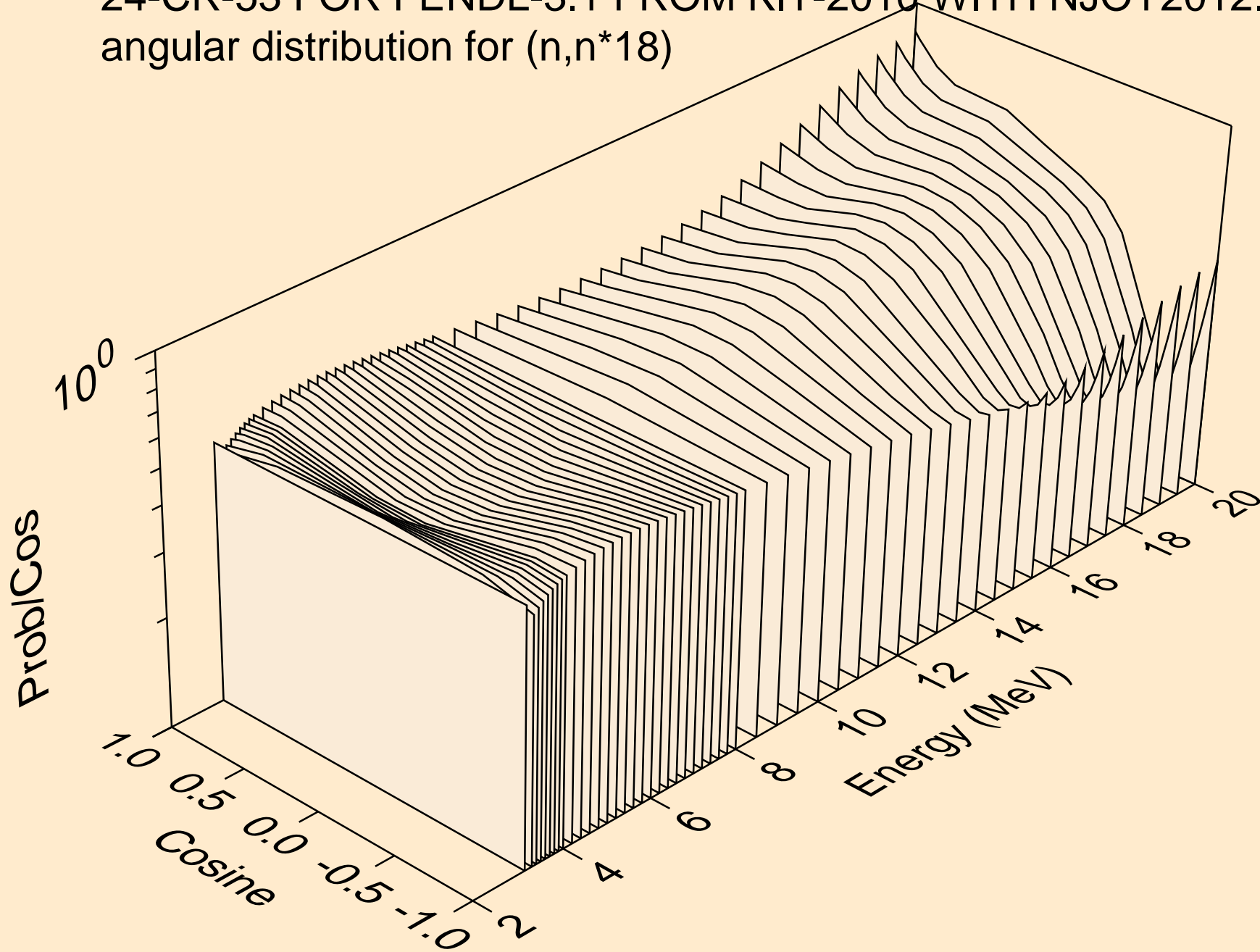

24-CR-53 FOR FENDL-3.1 FROM KIT-2010 WITH NJOY2012.50+ C
angular distribution for (n,n*18)

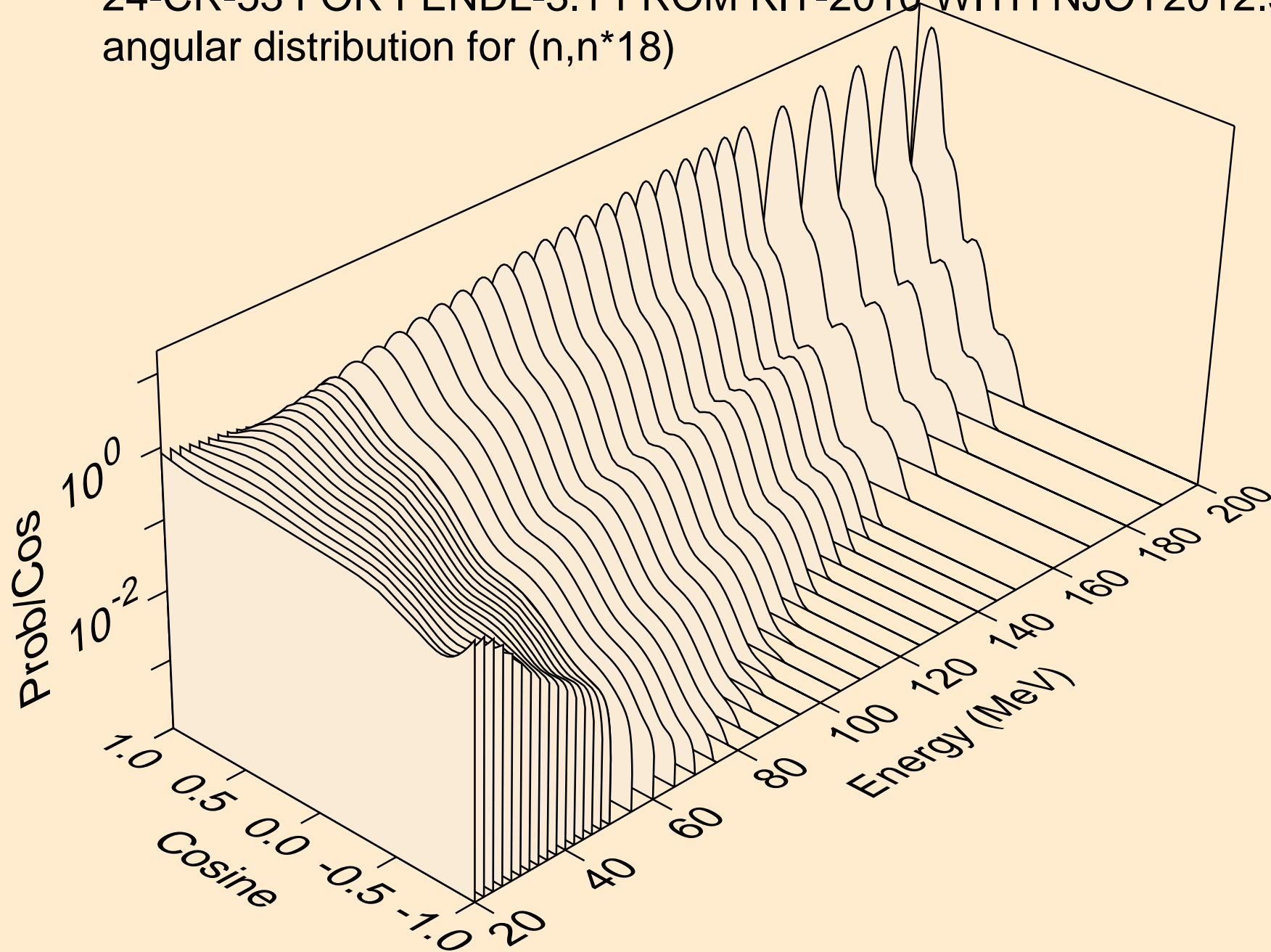

24-CR-53 FOR FENDL-3.1 FROM KIT-2010 WITH NJOY2012.50+ C
angular distribution for (n,n*19)

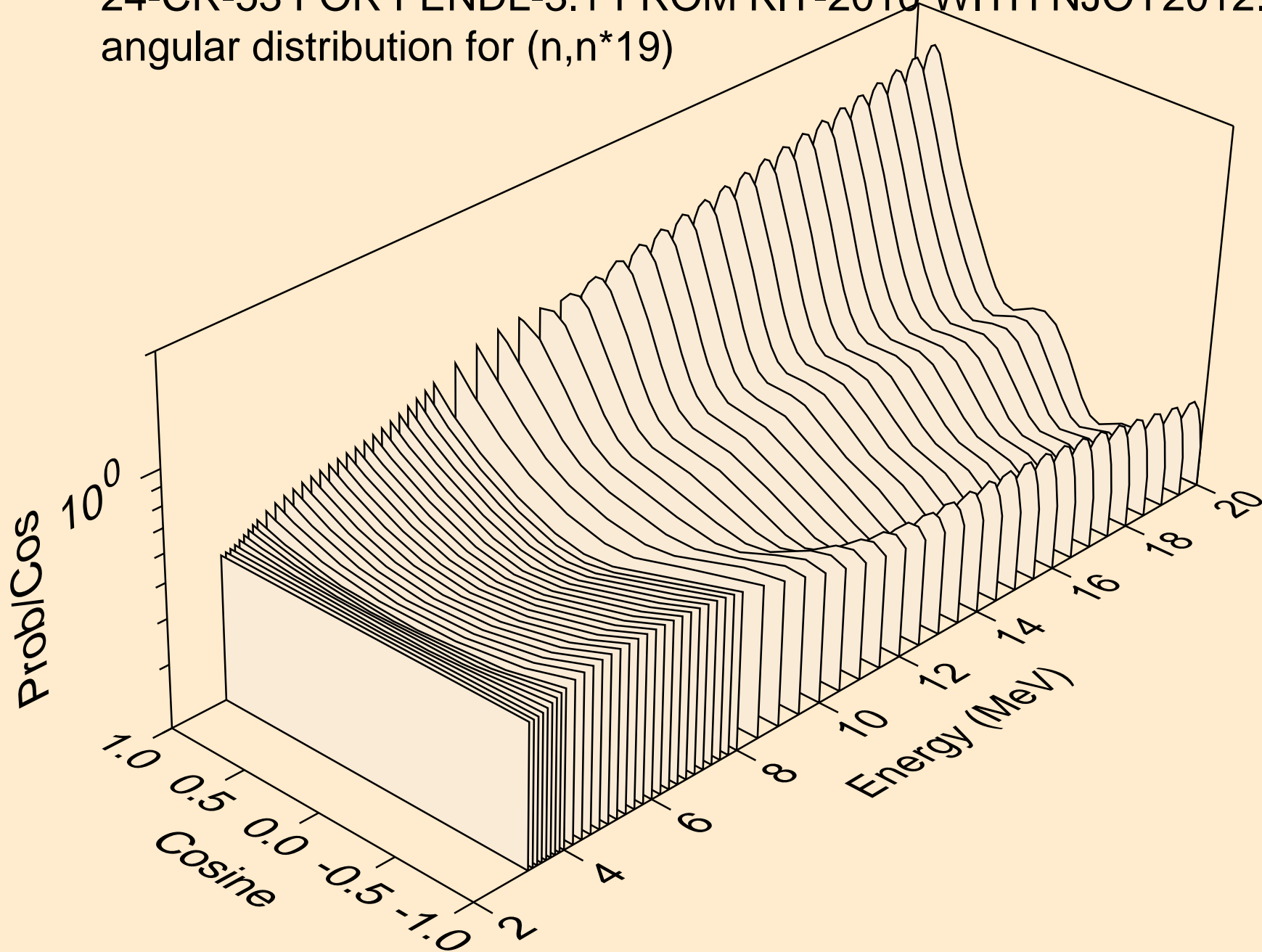

24-CR-53 FOR FENDL-3.1 FROM KIT-2010 WITH NJOY2012.50+ C
angular distribution for (n,n*19)

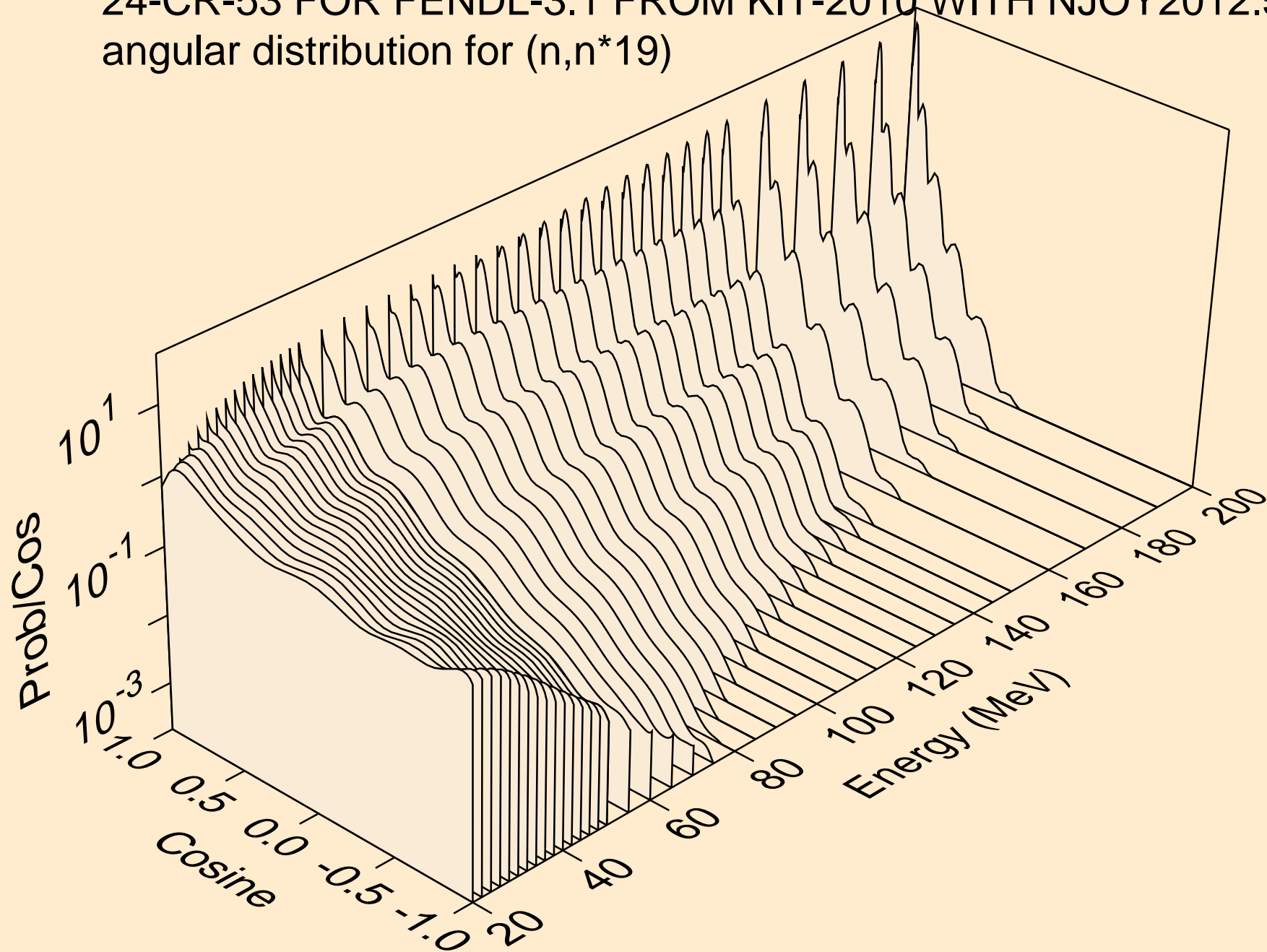

24-CR-53 FOR FENDL-3.1 FROM KIT-2010 WITH NJOY2012.50+ C
angular distribution for (n,n*20)

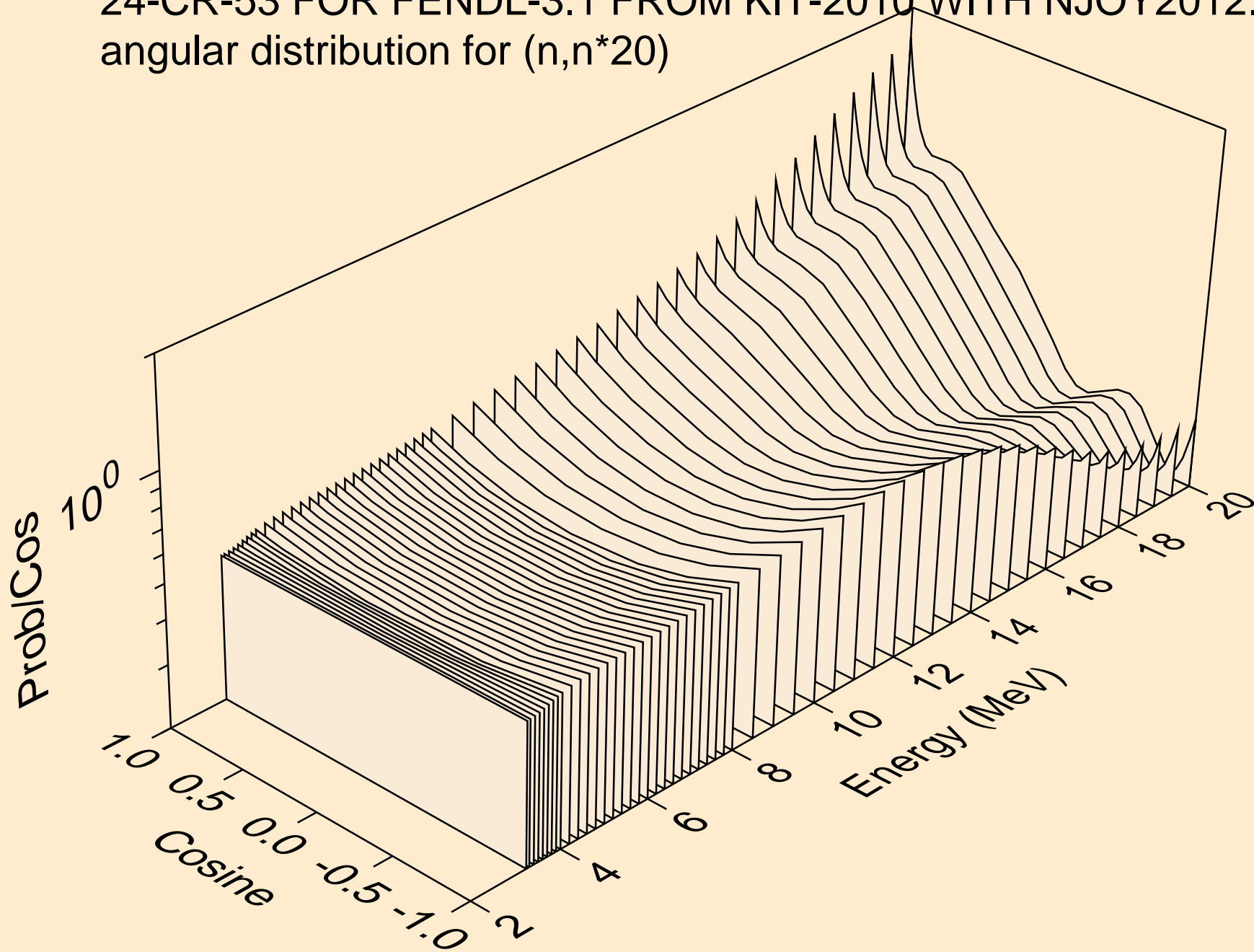

24-CR-53 FOR FENDL-3.1 FROM KIT-2010 WITH NJOY2012.50+ C
angular distribution for (n,n*20)

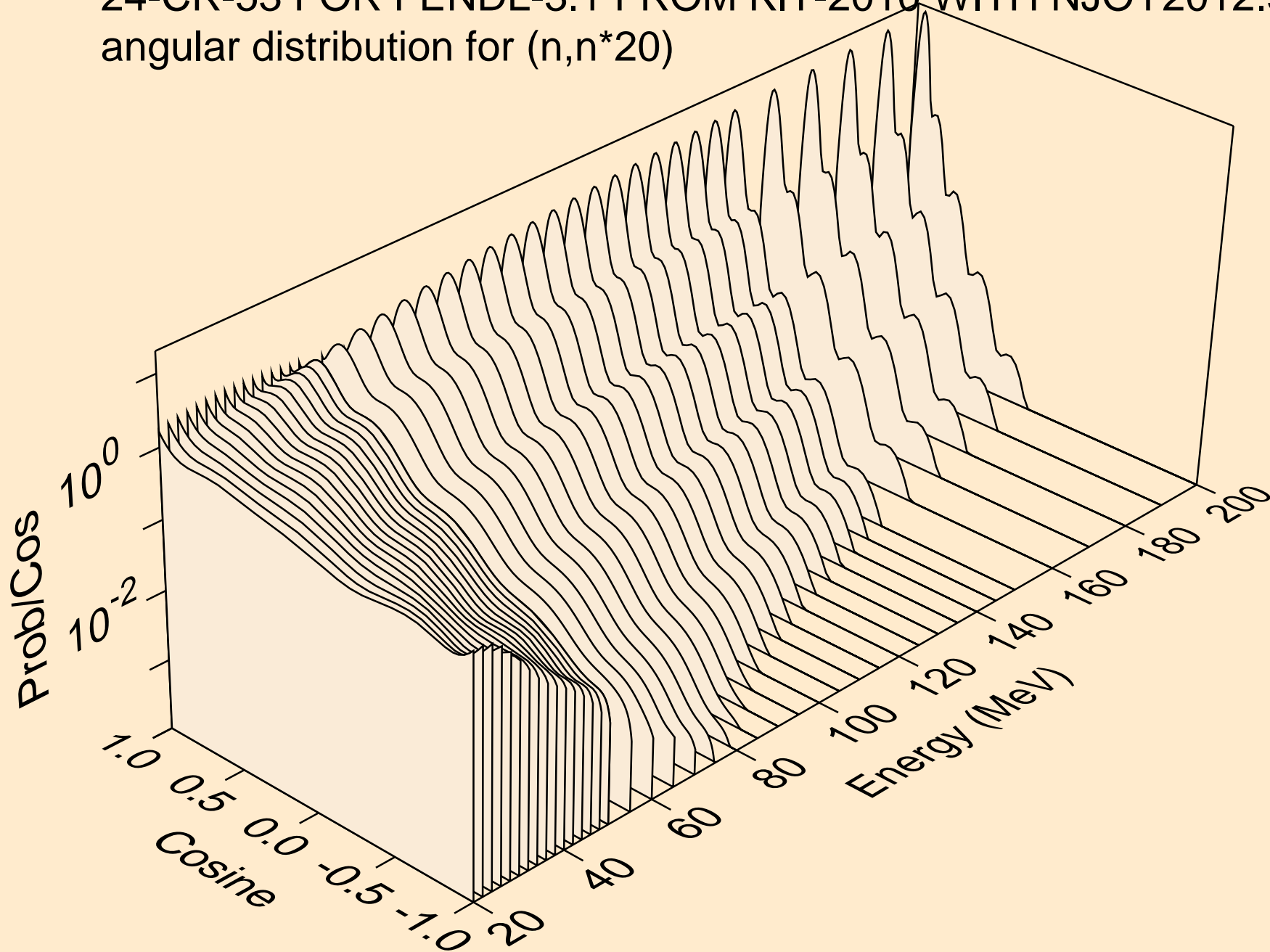

24-CR-53 FOR FENDL-3.1 FROM KIT-2010 WITH NJOY2012.50+ C
Neutron emission for (n,x)

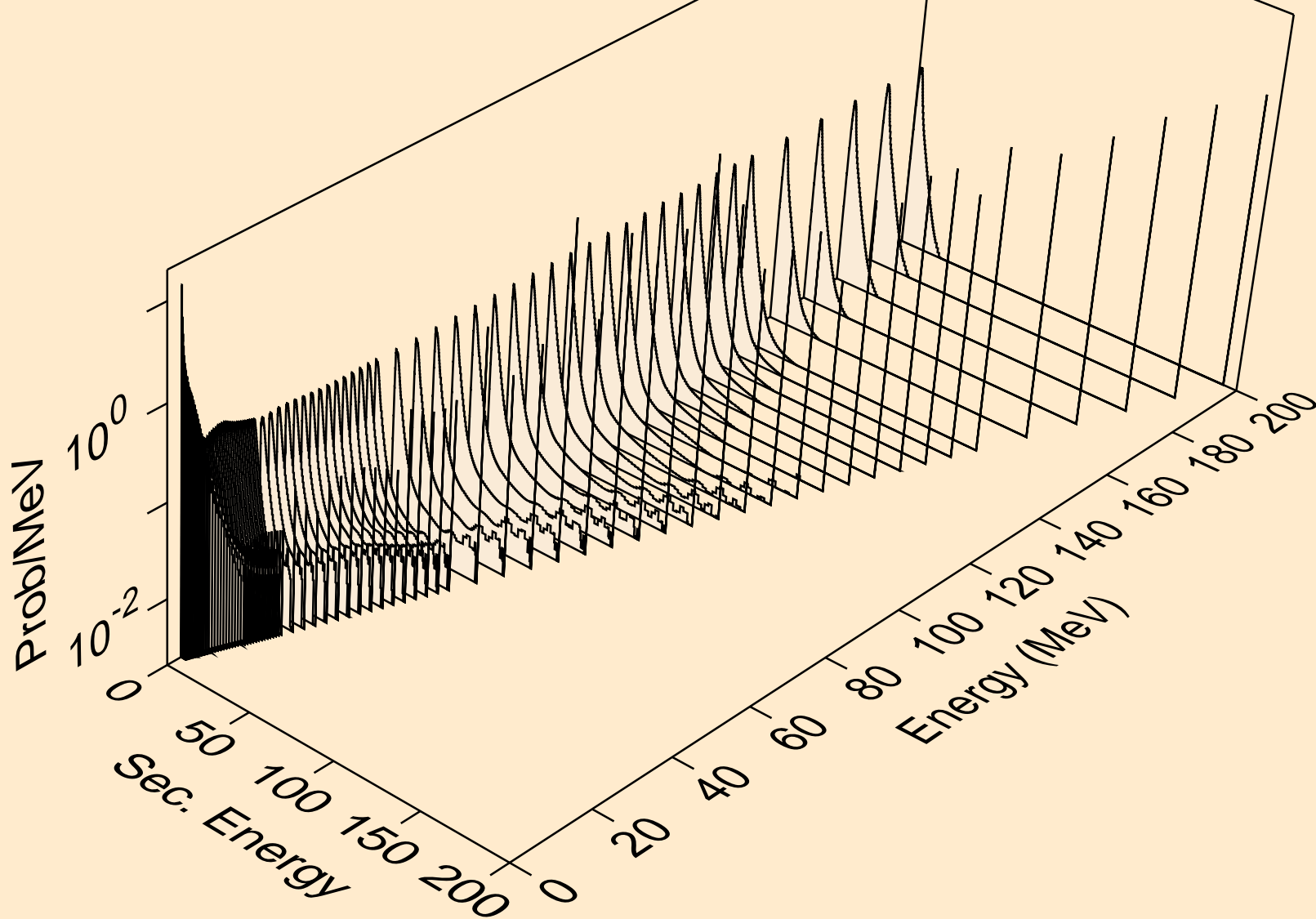

24-CR-53 FOR FENDL-3.1 FROM KIT-2010 WITH NJOY2012.50+ C
Photon emission for (n,x)

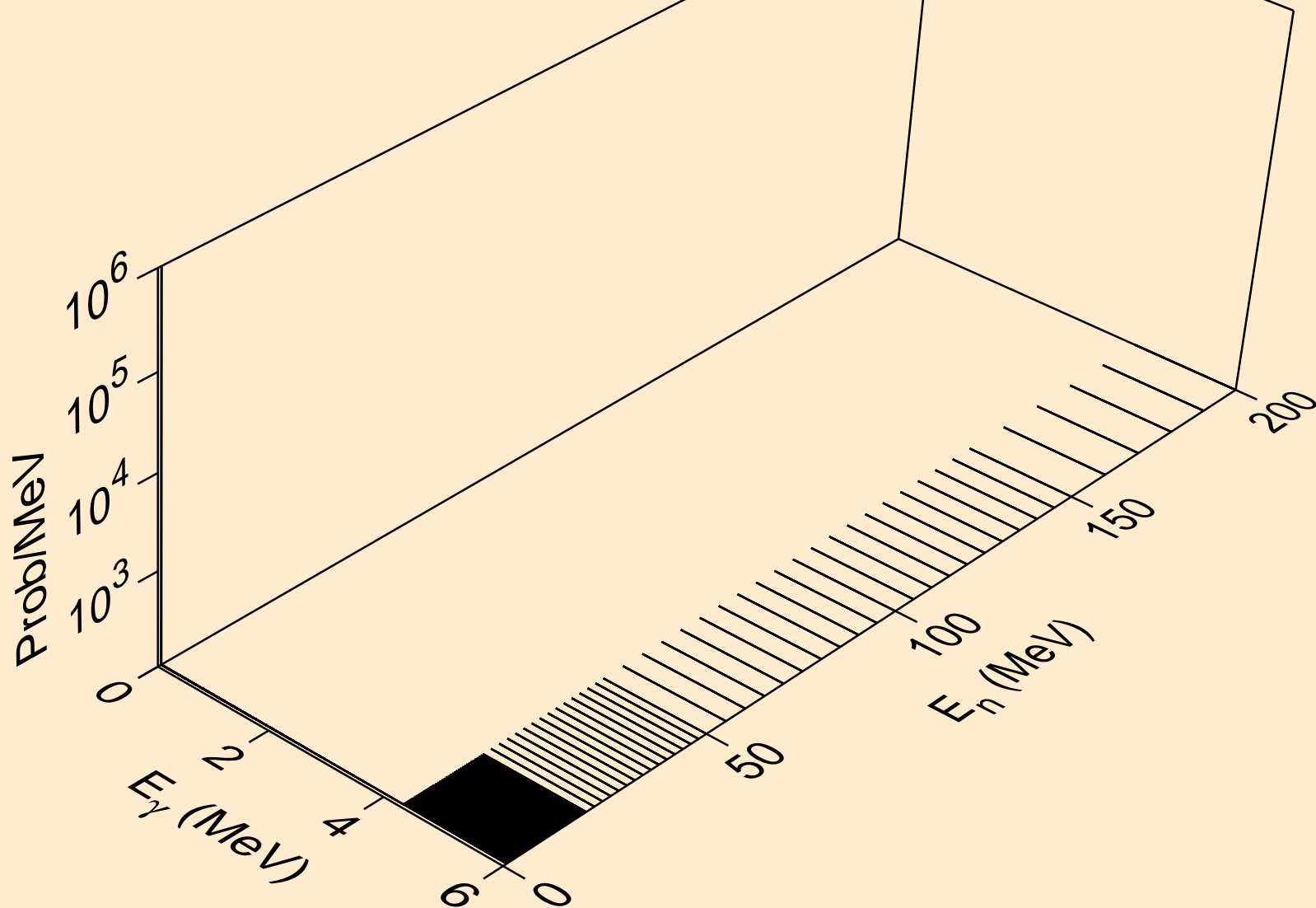

24-CR-53 FOR FENDL-3.1 FROM KIT-2010 WITH NJOY2012.50+ C
Photon emission for (n,gma)

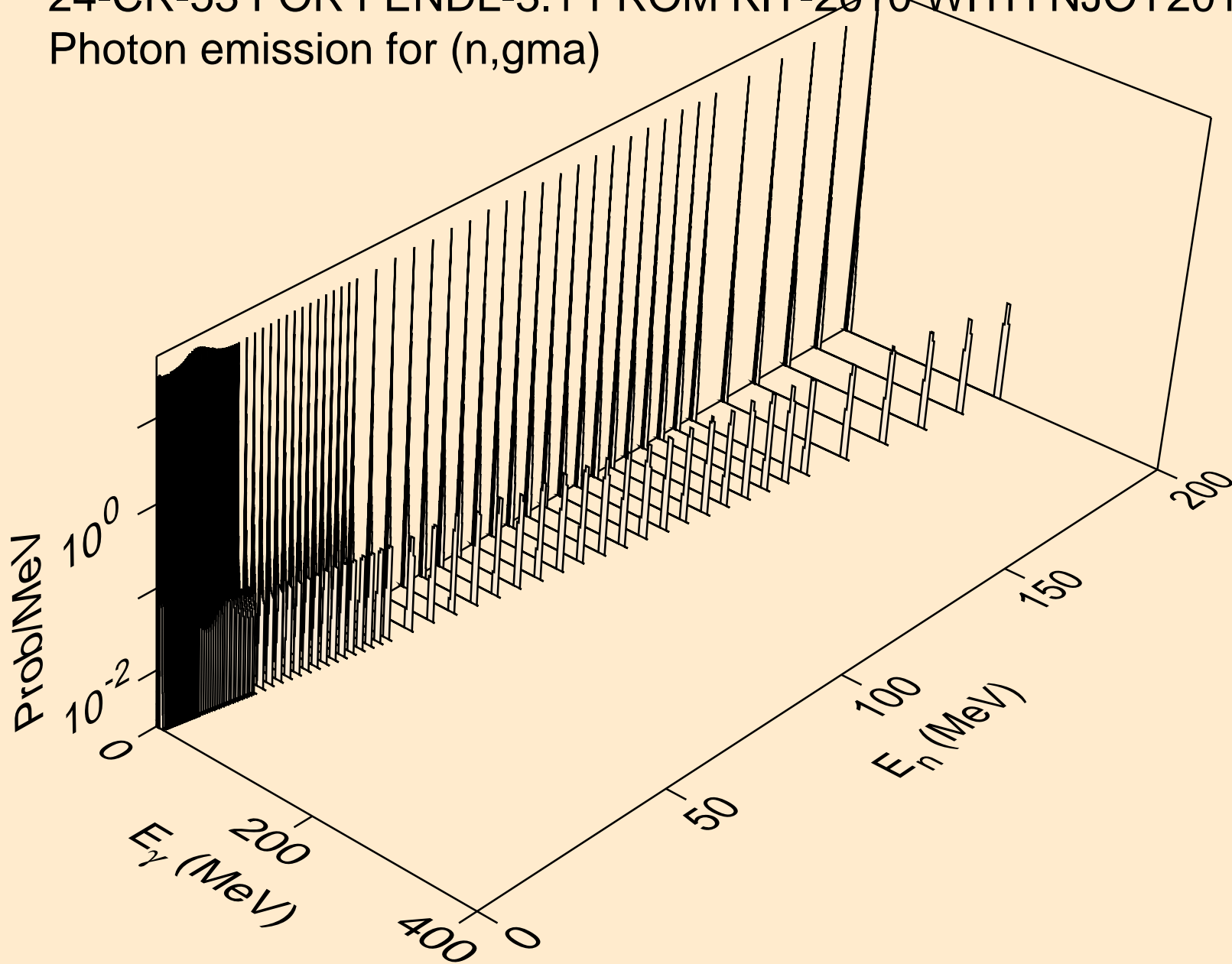

24-CR-53 FOR FENDL-3.1 FROM KIT-2010 WITH NJOY2012.50+ C
thermal capture photon spectrum

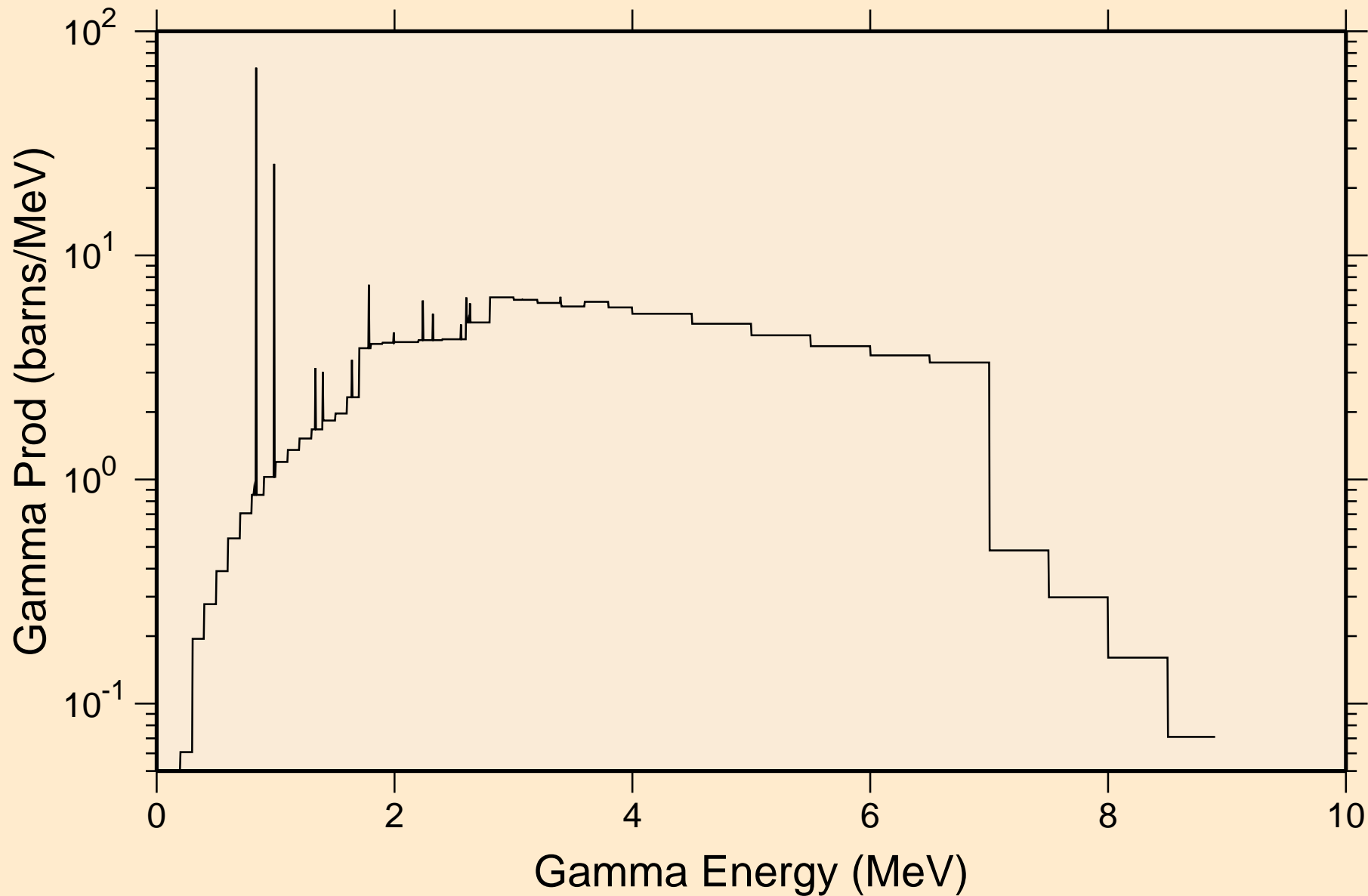

24-CR-53 FOR FENDL-3.1 FROM KIT-2010 WITH NJOY2012.50+ C
14 MeV photon spectrum

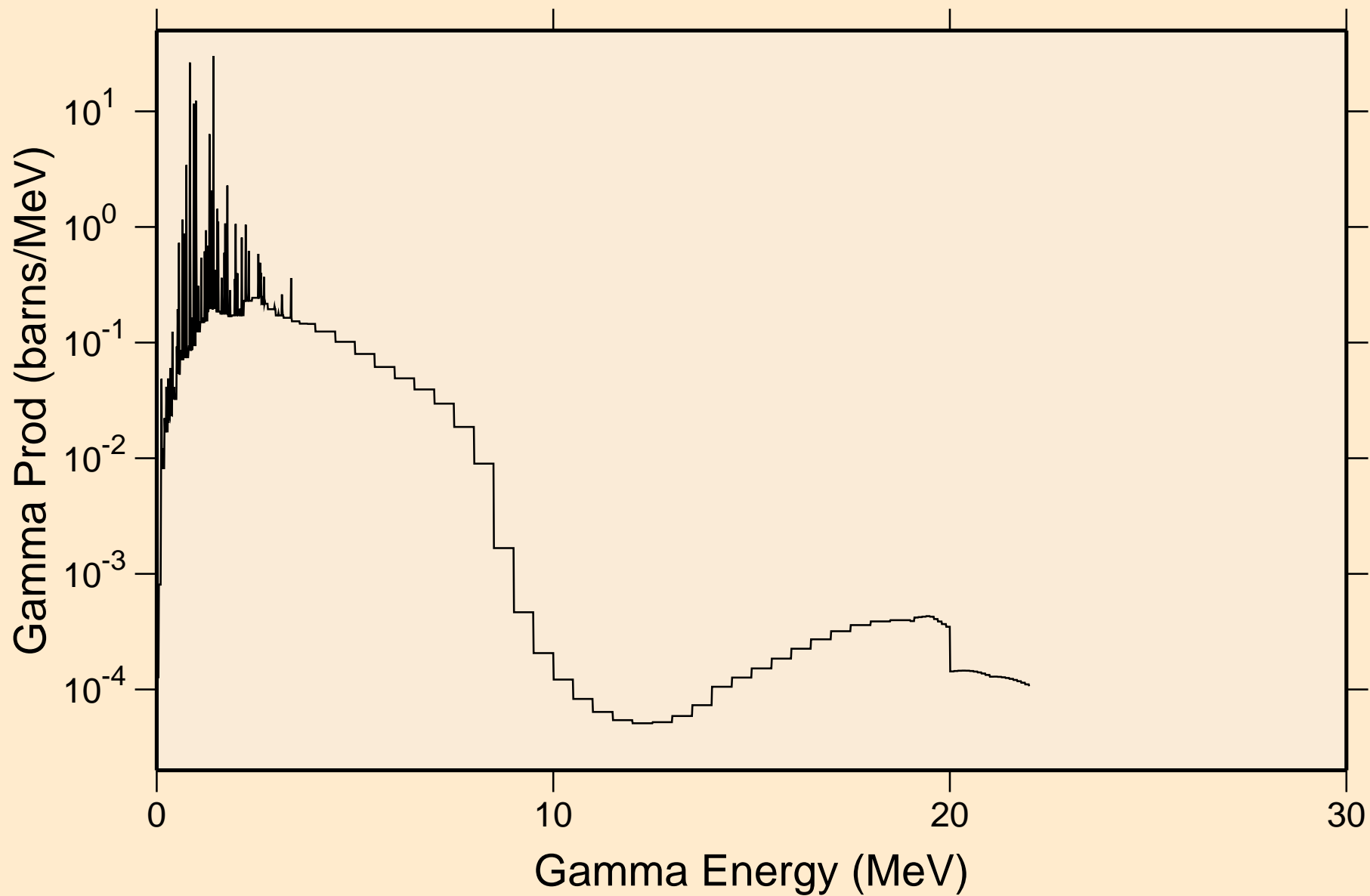

24-CR-53 FOR FENDL-3.1 FROM KIT-2010 WITH NJOY2012.50+ C

Particle heating contributions

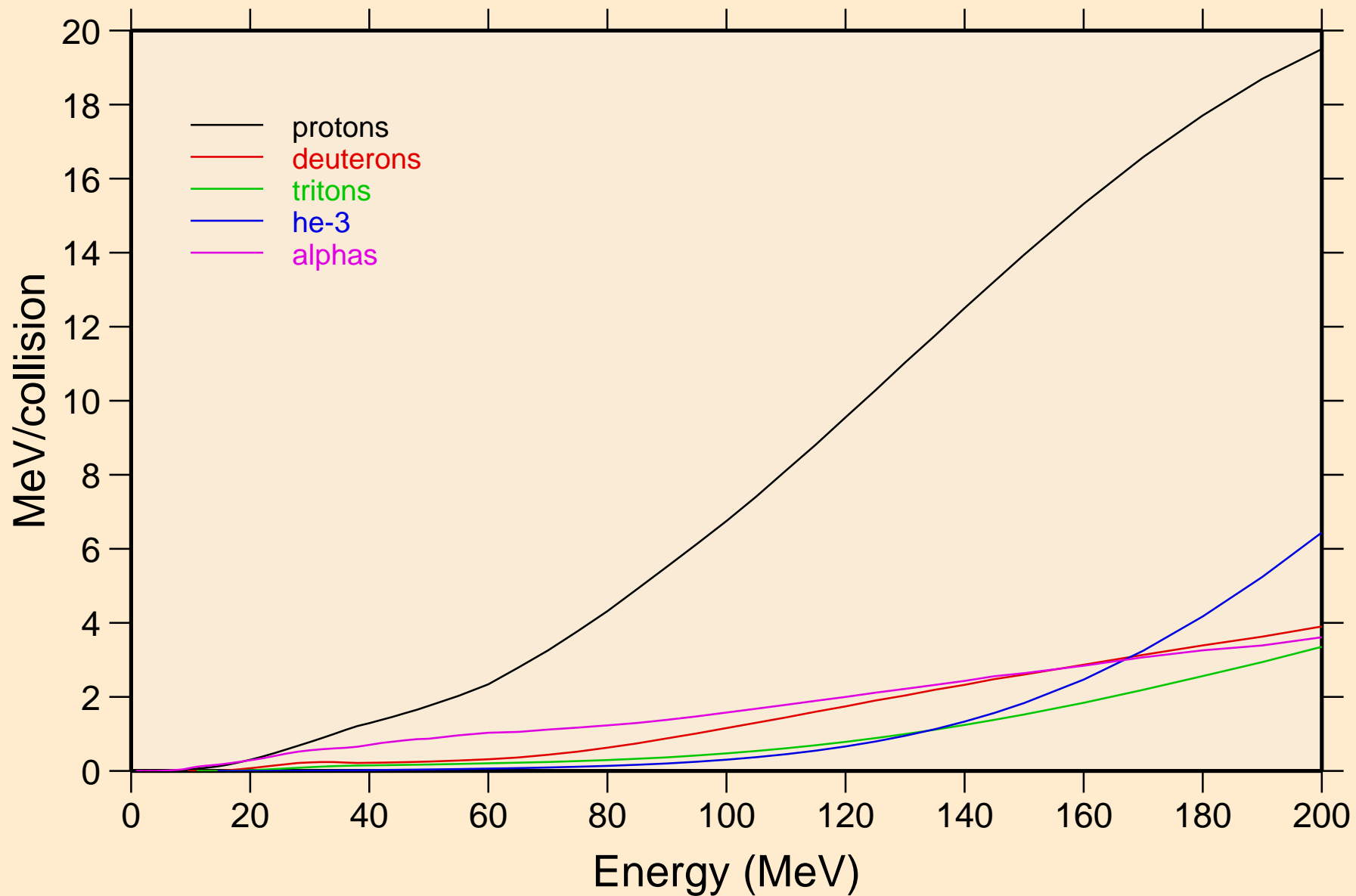

24-CR-53 FOR FENDL-3.1 FROM KIT-2010 WITH NJOY2012.50+ C Recoil Heating

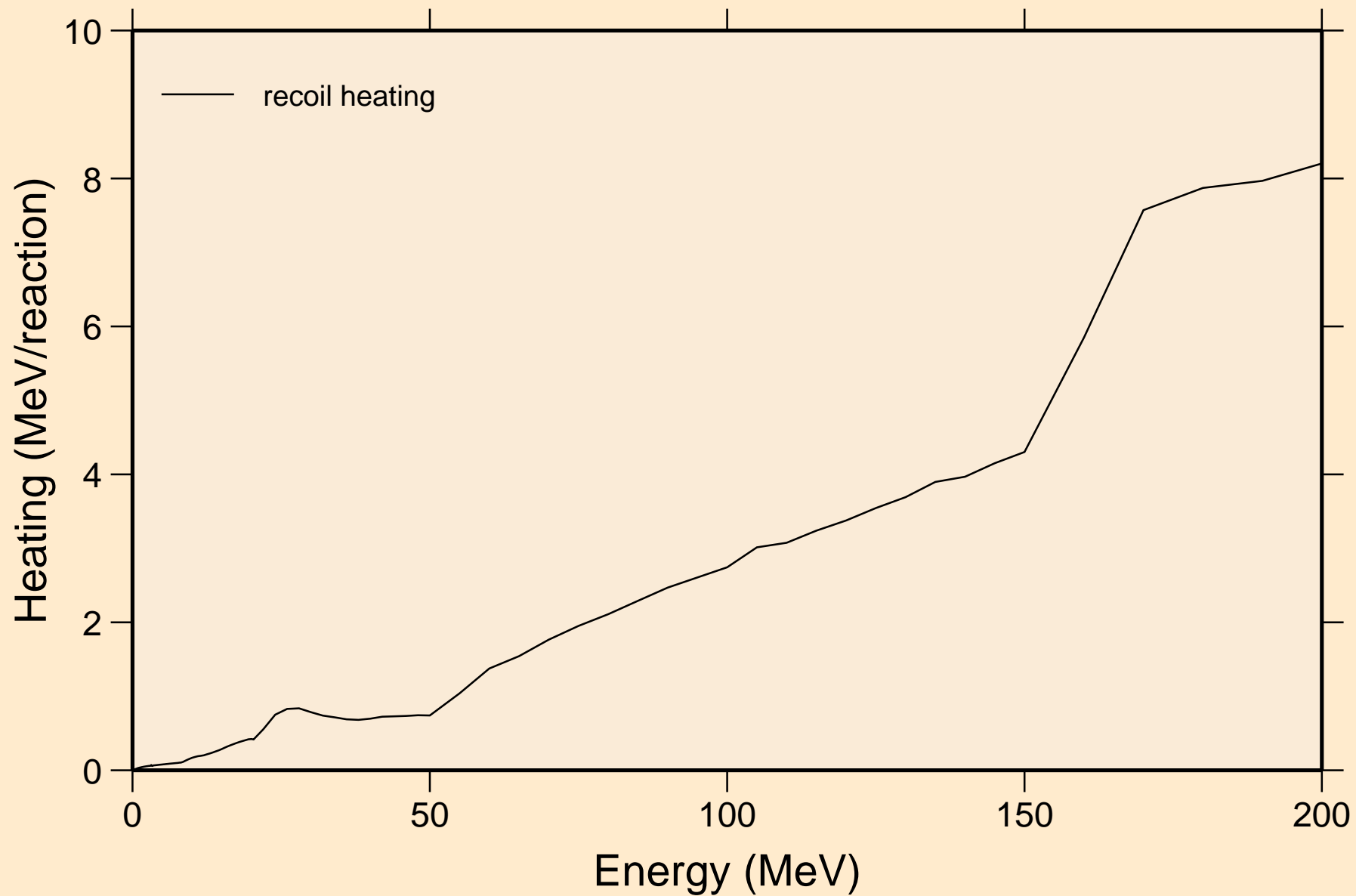

24-CR-53 FOR FENDL-3.1 FROM KIT-2010 WITH NJOY2012.50+ C

Particle production cross sections

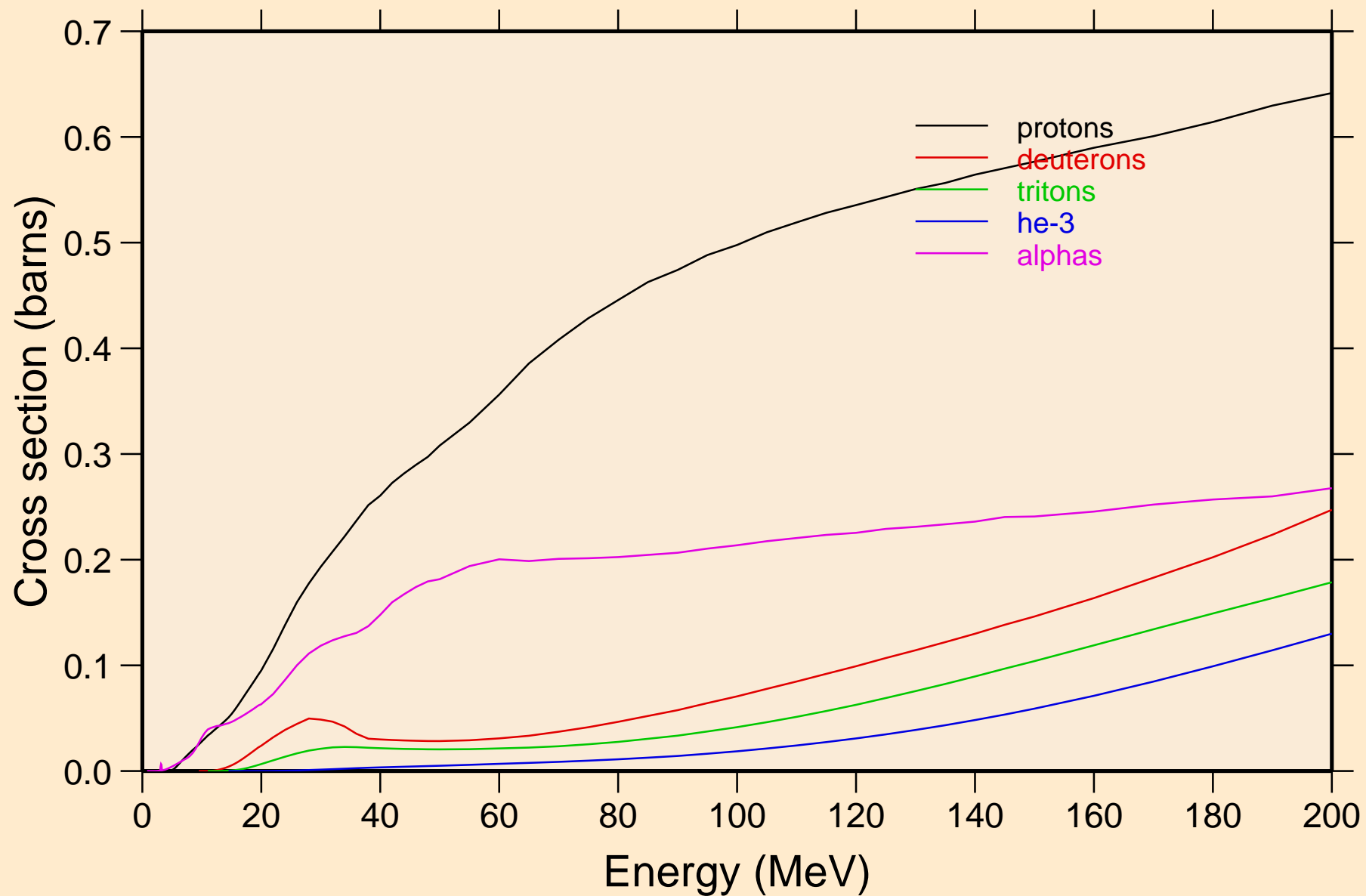

24-CR-53 FOR FENDL-3.1 FROM KIT-2010 WITH NJOY2012.50+ C
protons from (n,x)

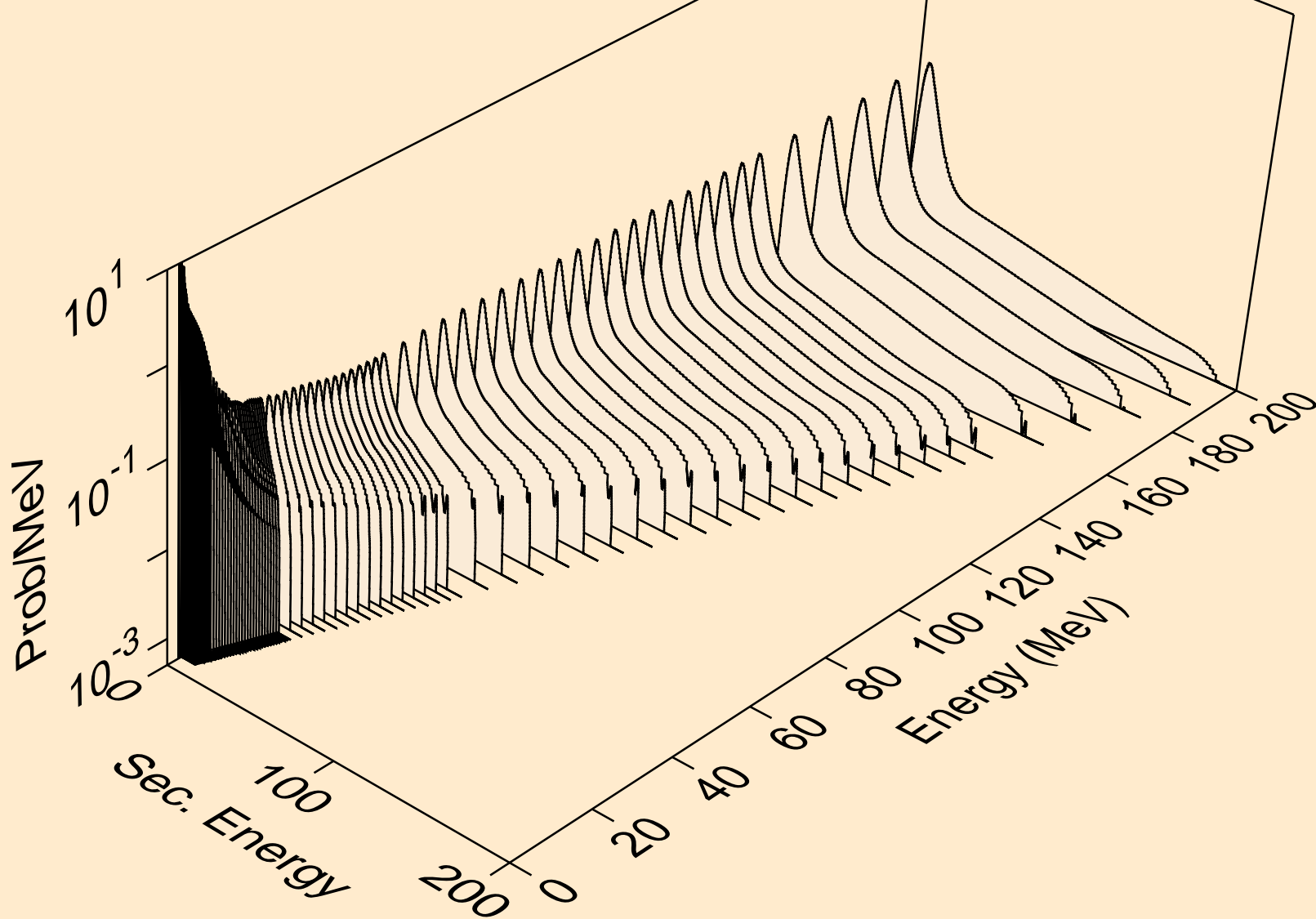

24-CR-53 FOR FENDL-3.1 FROM KIT-2010 WITH NJOY2012.50+ C
deuterons from (n,x)

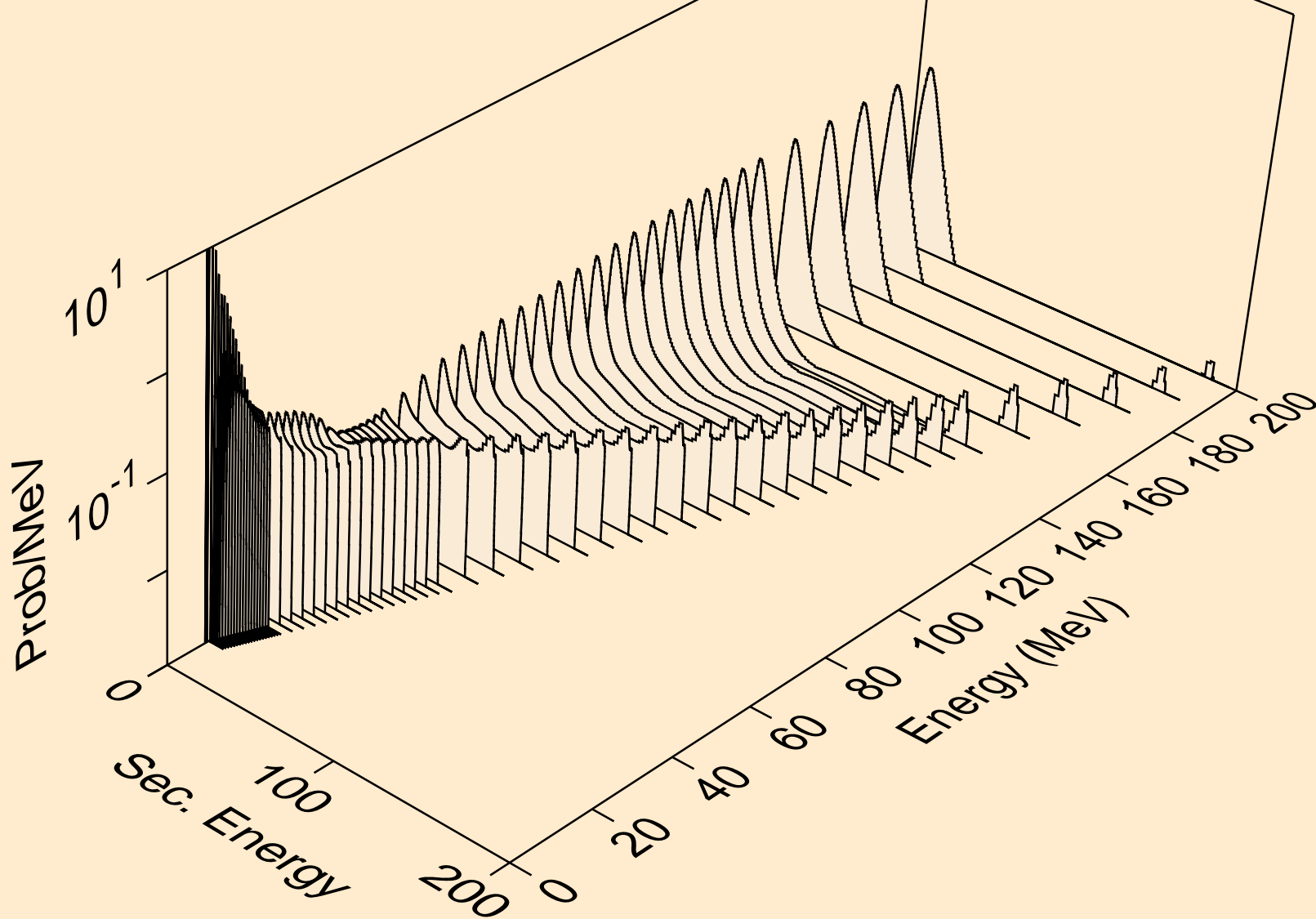

24-CR-53 FOR FENDL-3.1 FROM KIT-2010 WITH NJOY2012.50+ C
tritons from (n,x)

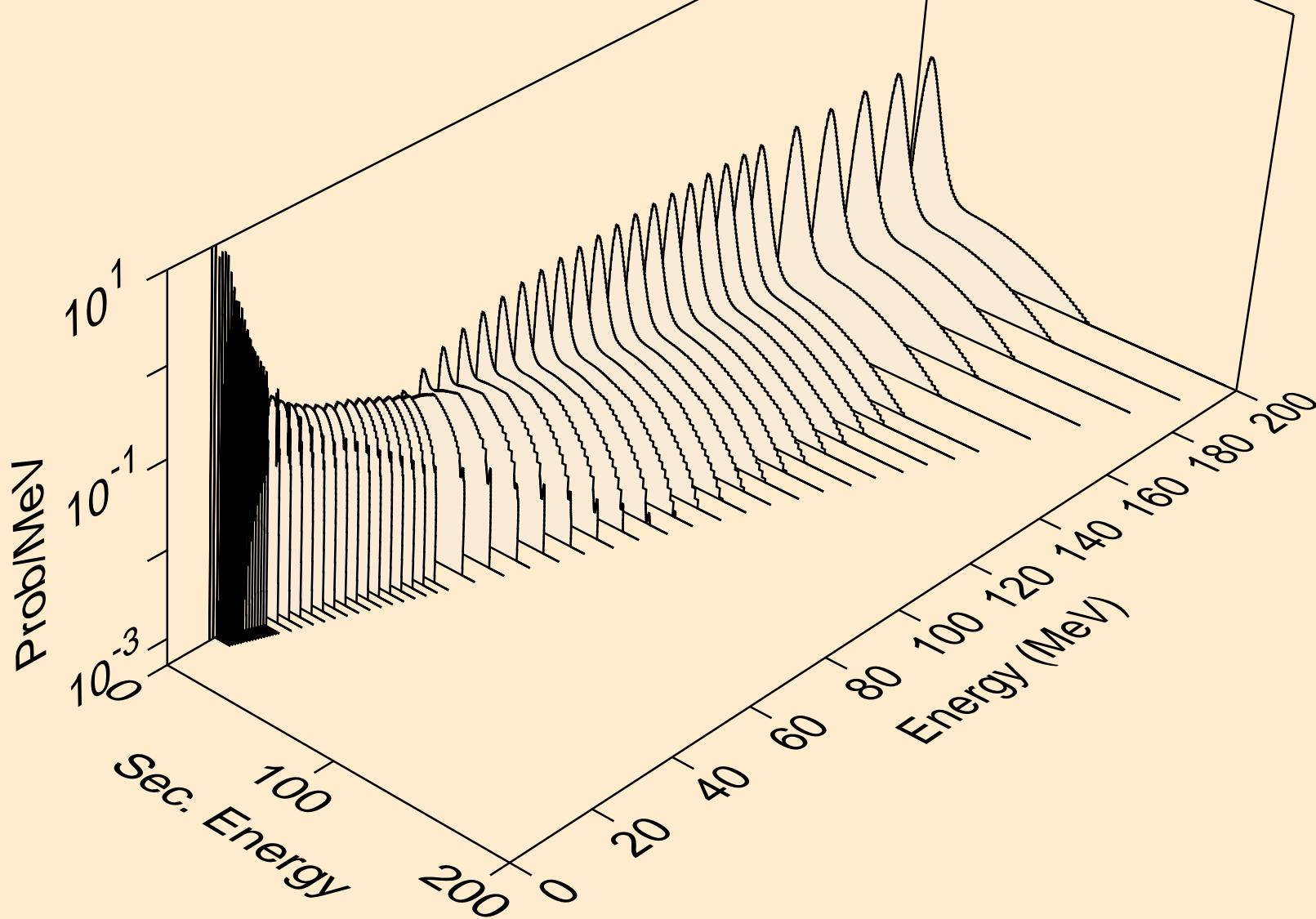

24-CR-53 FOR FENDL-3.1 FROM KIT-2010 WITH NJOY2012.50+ C
he3s from (n,x)

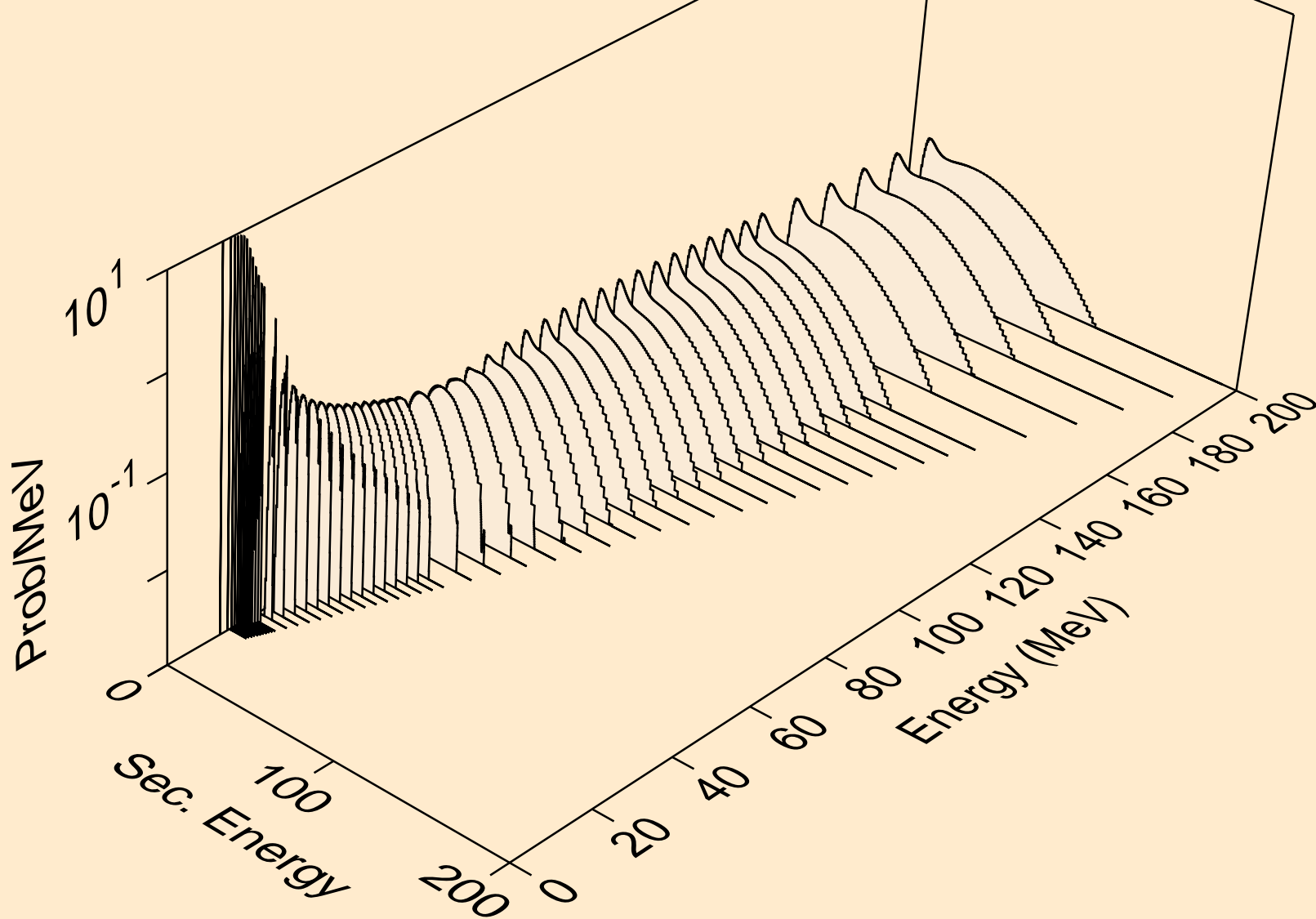

24-CR-53 FOR FENDL-3.1 FROM KIT-2010 WITH NJOY2012.50+ C
alphas from (n,x)

