

30-ZN-64 FOR FENDL-3.1 FROM FENDL-3.1 WITH NJOY2012.50+
Principal cross sections

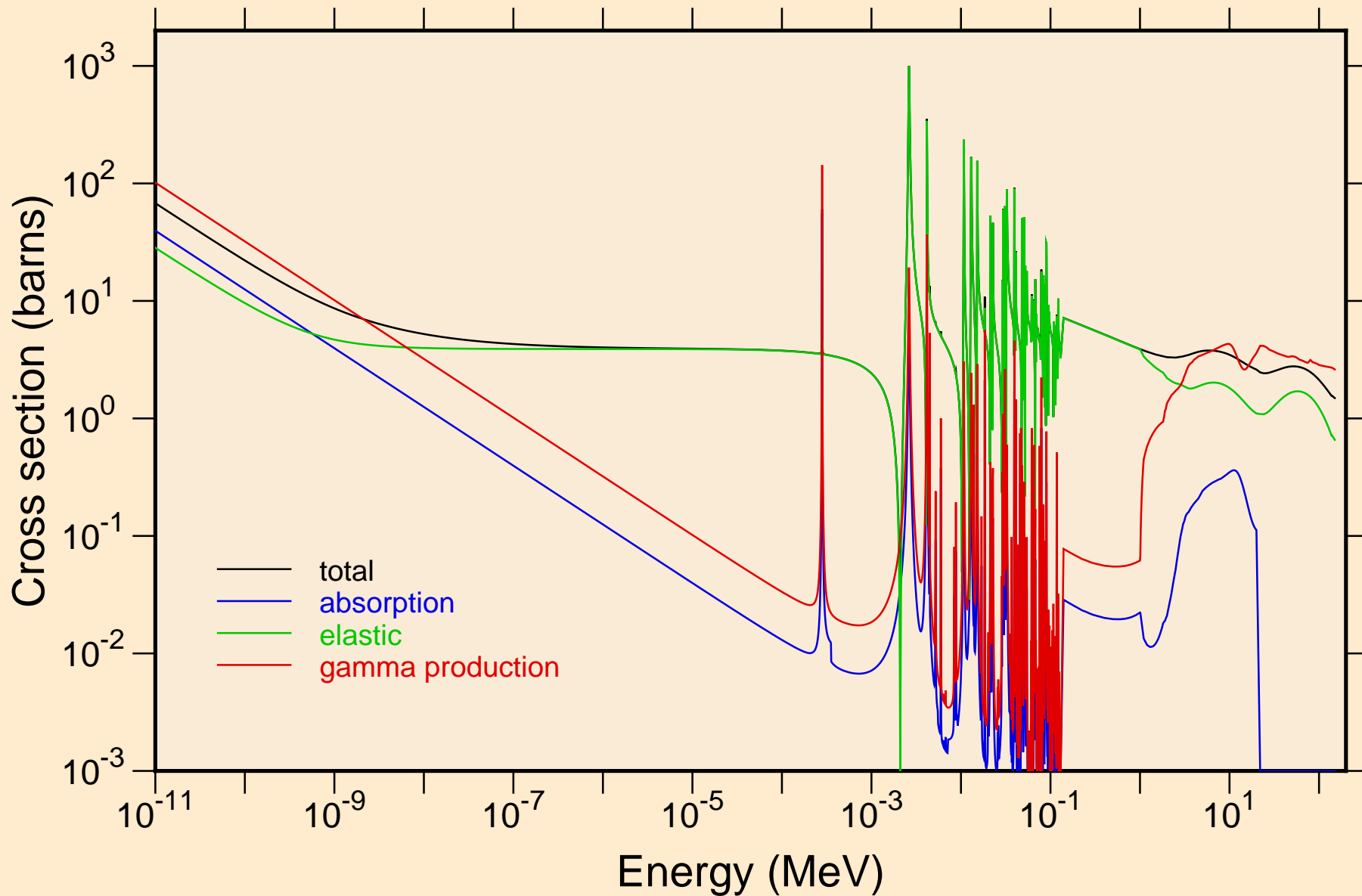

30-ZN-64 FOR FENDL-3.1 FROM FENDL-3.1 WITH NJOY2012.50+
resonance total cross section

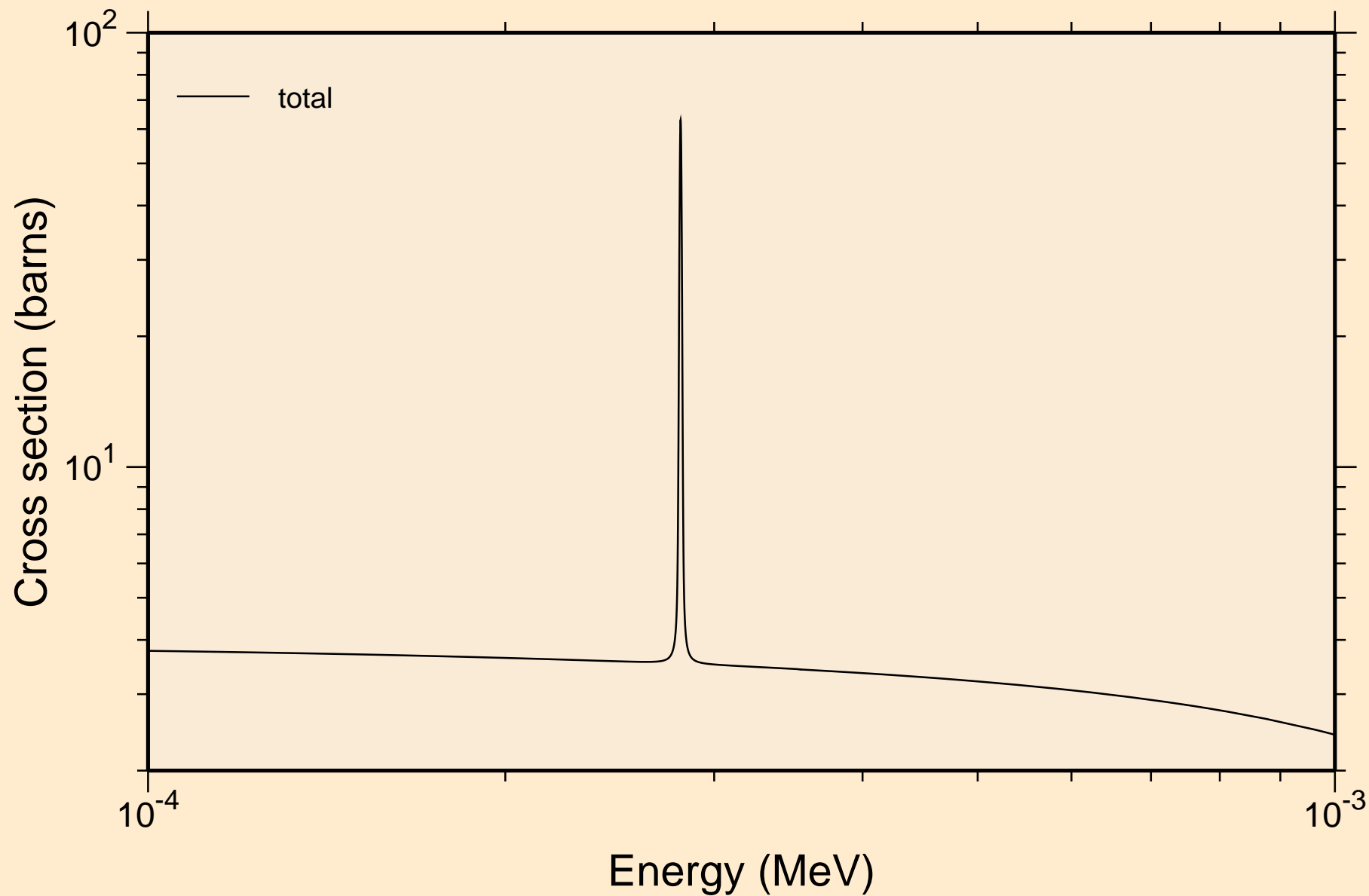

30-ZN-64 FOR FENDL-3.1 FROM FENDL-3.1 WITH NJOY2012.50+
resonance total cross section

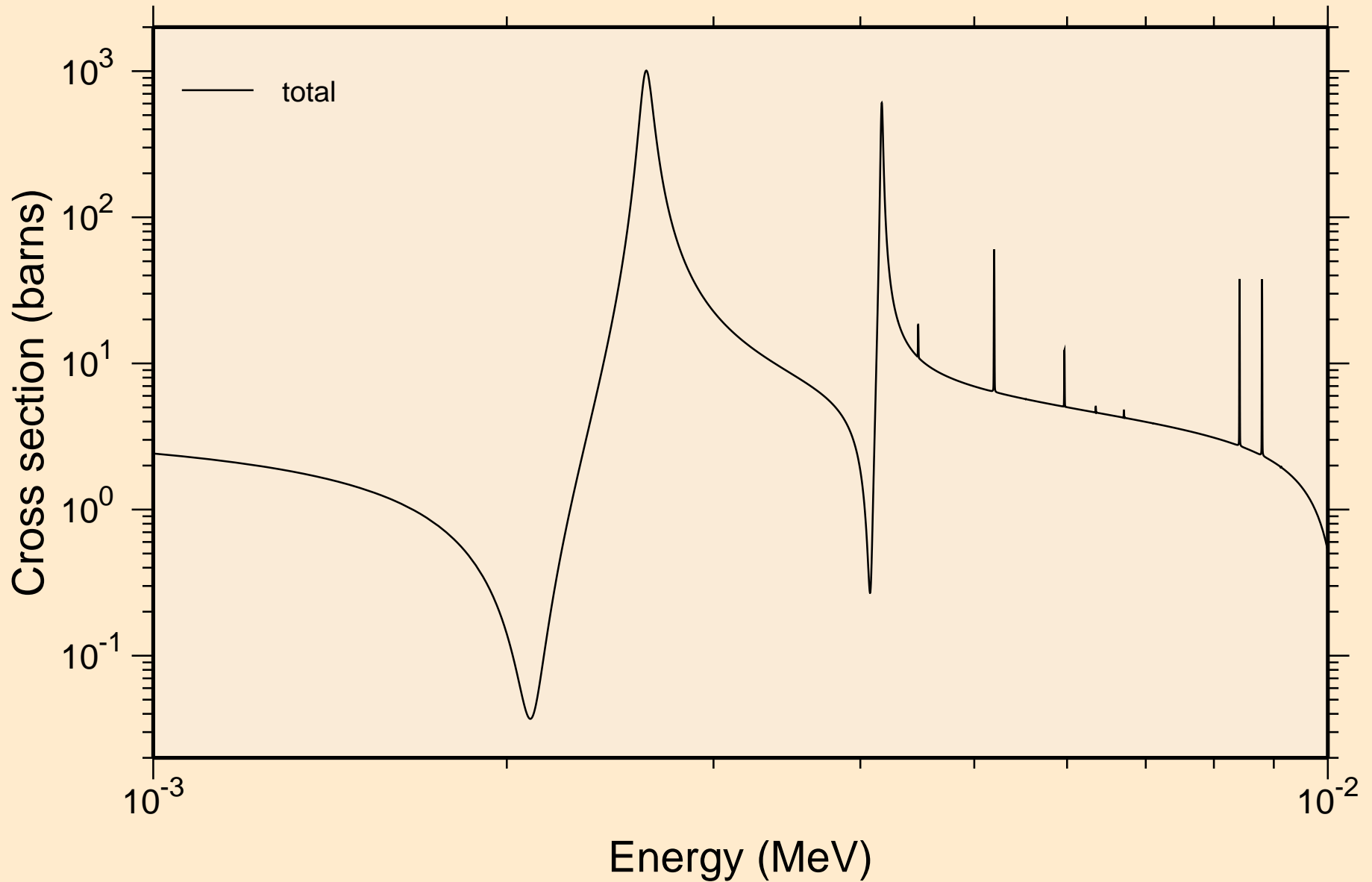

30-ZN-64 FOR FENDL-3.1 FROM FENDL-3.1 WITH NJOY2012.50+
resonance total cross section

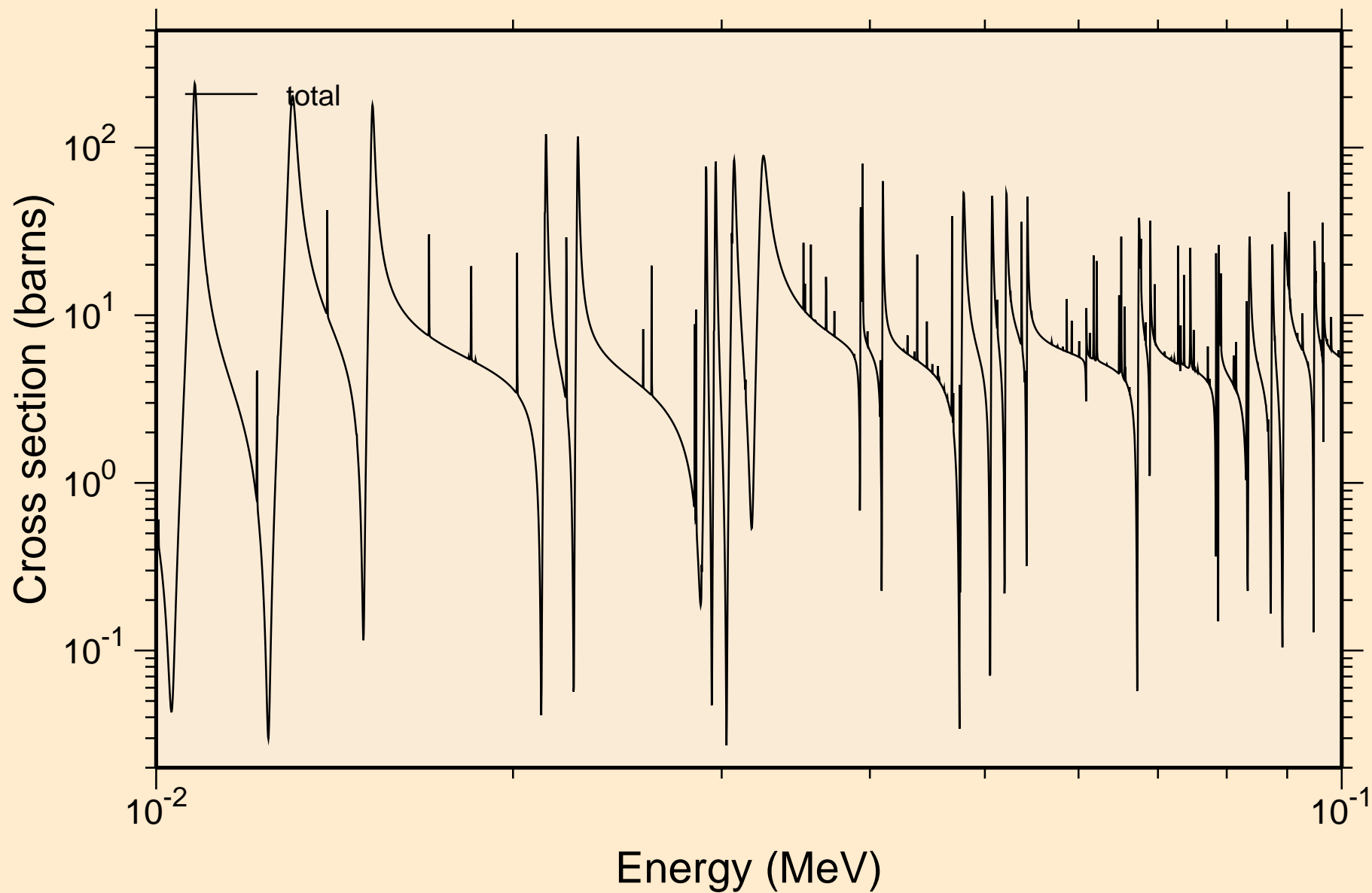

30-ZN-64 FOR FENDL-3.1 FROM FENDL-3.1 WITH NJOY2012.50+
resonance total cross section

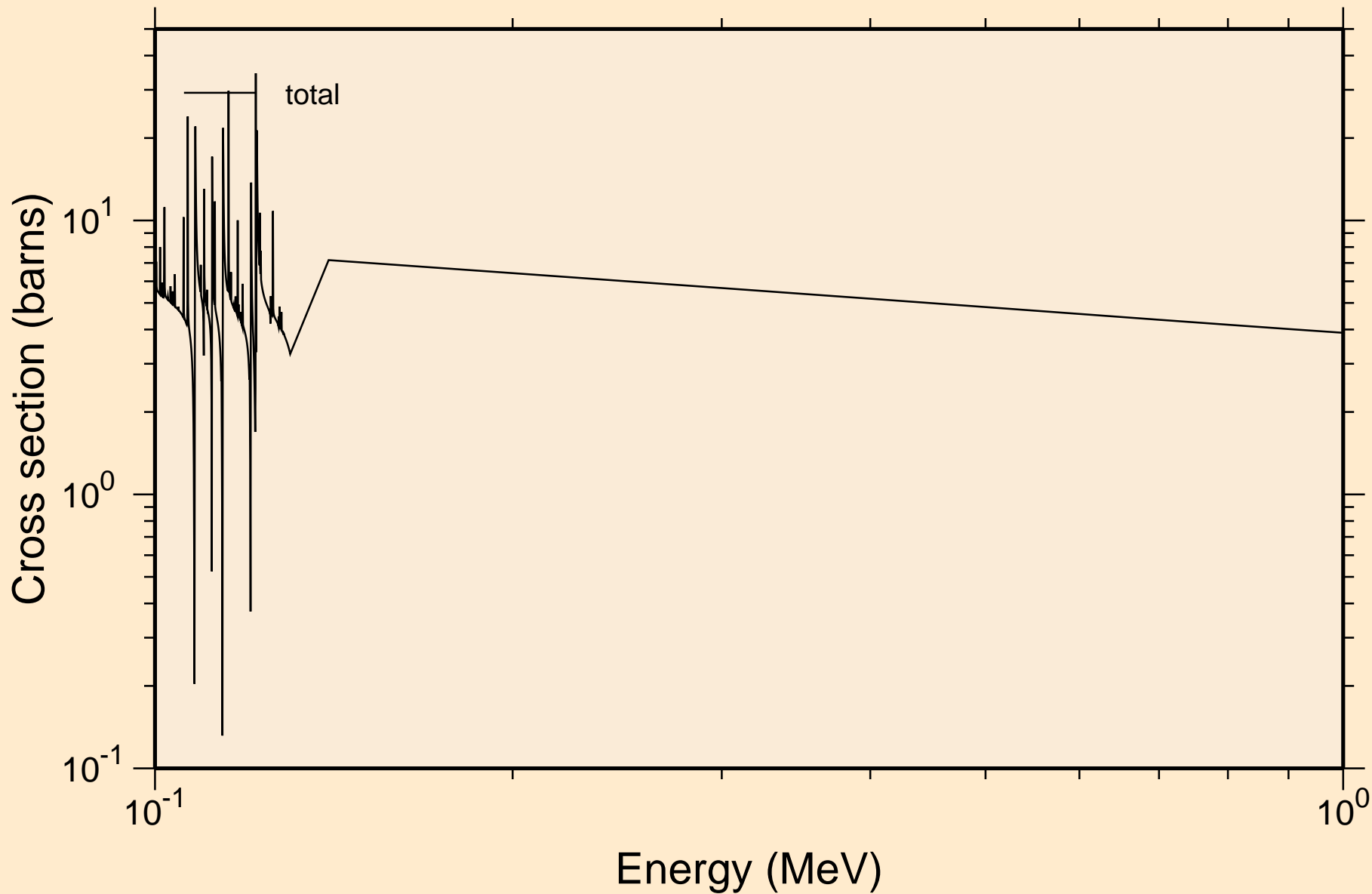

30-ZN-64 FOR FENDL-3.1 FROM FENDL-3.1 WITH NJOY2012.50+
resonance total cross section

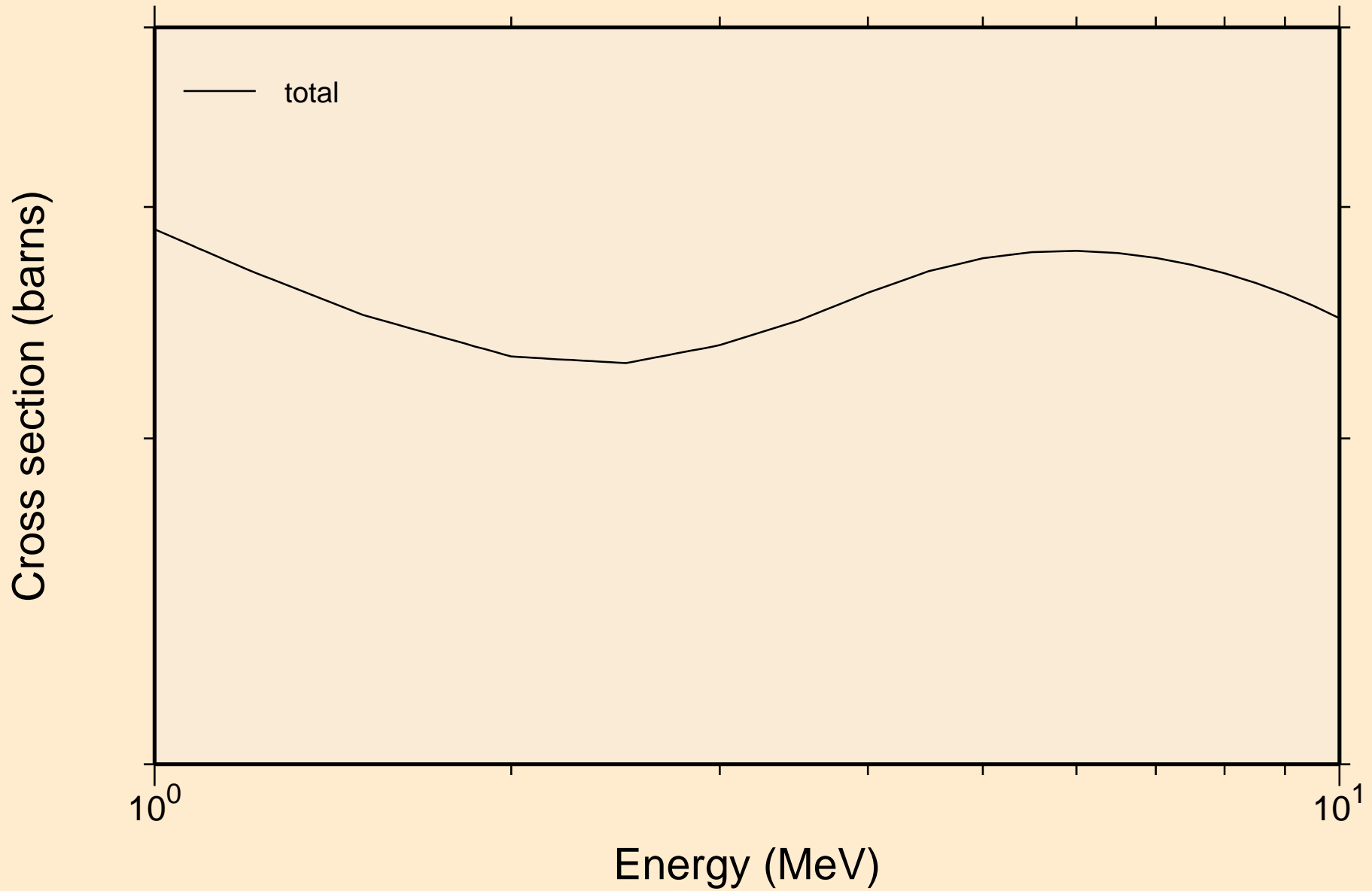

30-ZN-64 FOR FENDL-3.1 FROM FENDL-3.1 WITH NJOY2012.50+
resonance absorption cross sections

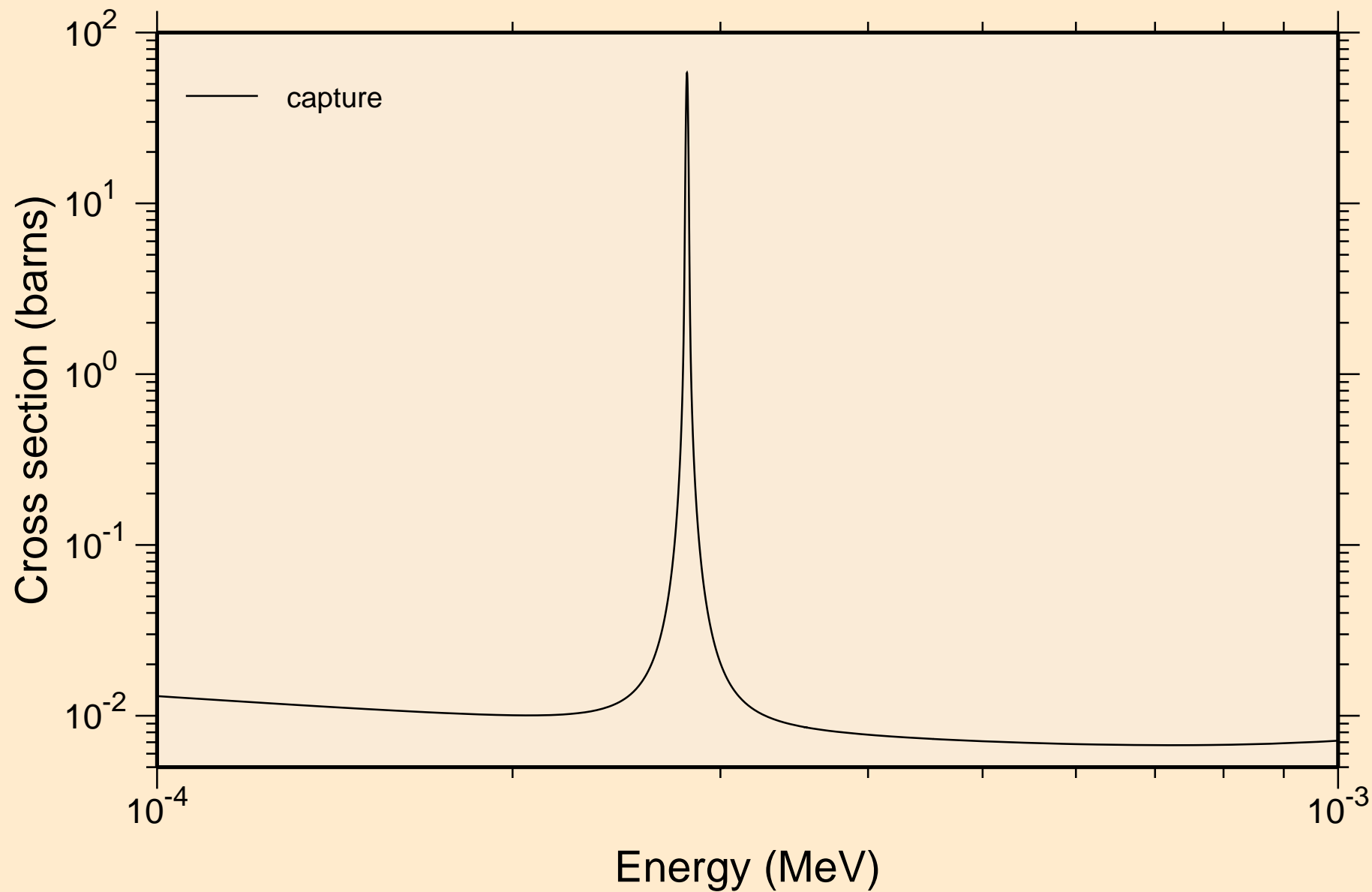

30-ZN-64 FOR FENDL-3.1 FROM FENDL-3.1 WITH NJOY2012.50+
resonance absorption cross sections

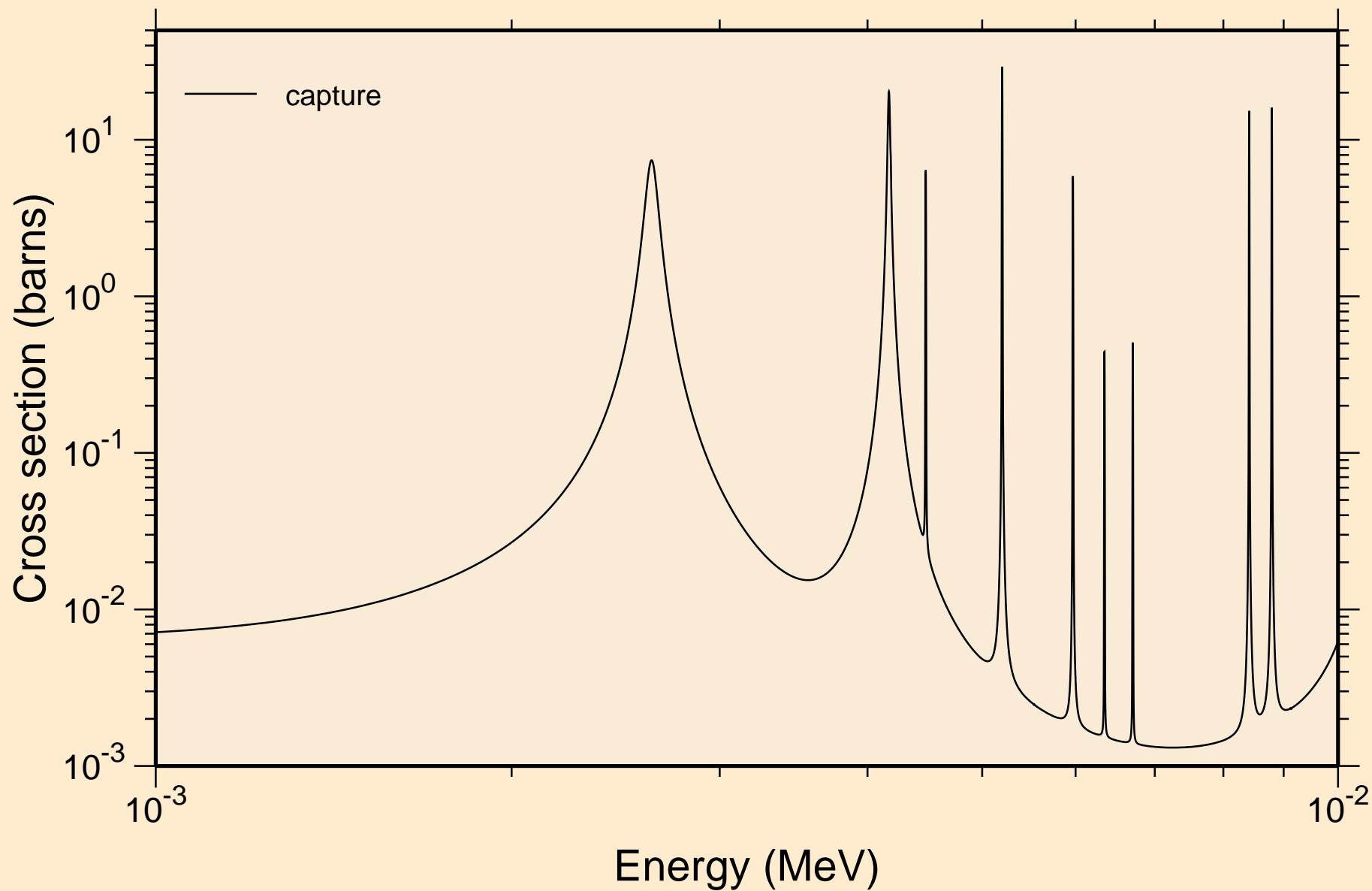

30-ZN-64 FOR FENDL-3.1 FROM FENDL-3.1 WITH NJOY2012.50+
resonance absorption cross sections

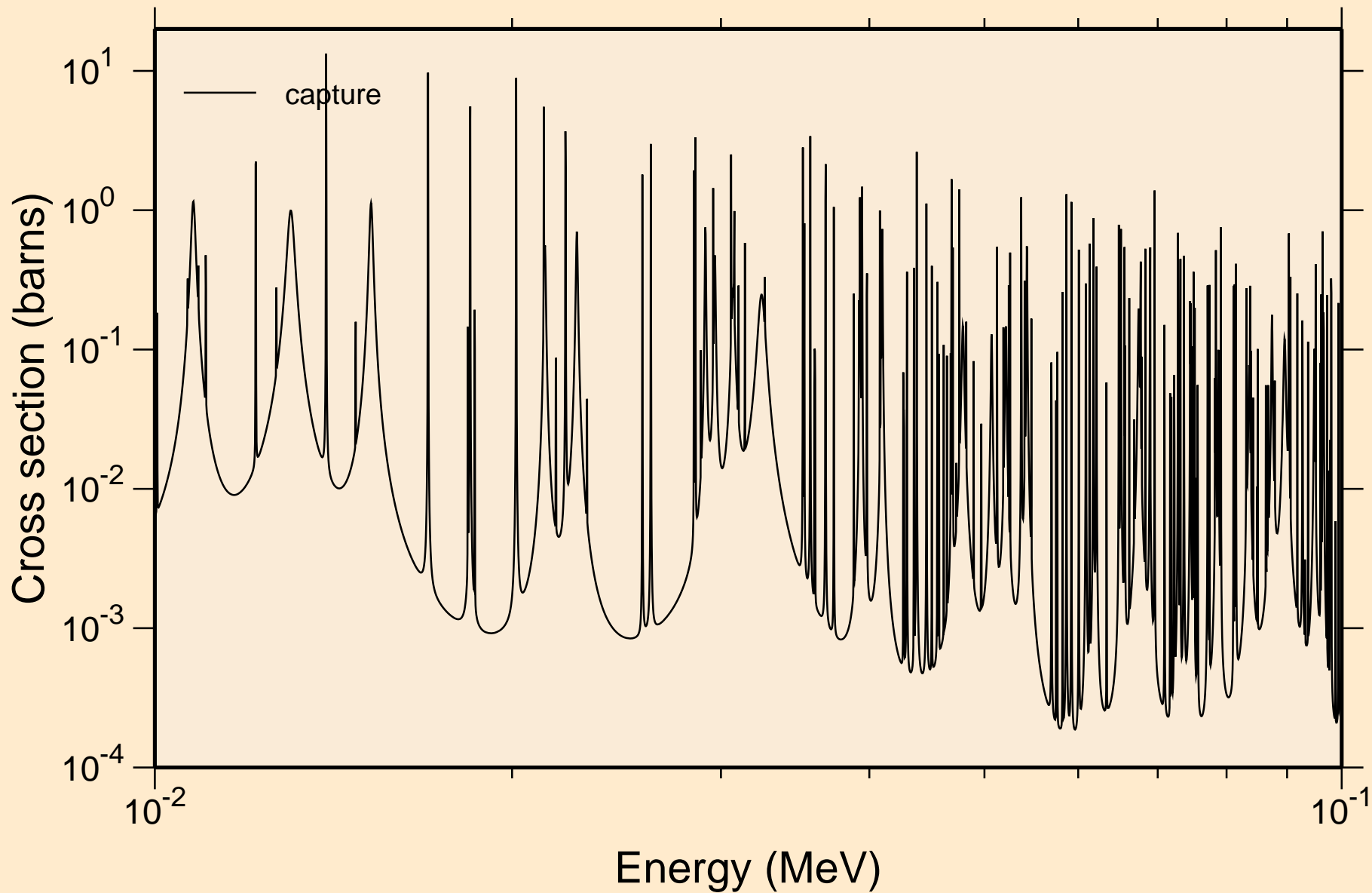

30-ZN-64 FOR FENDL-3.1 FROM FENDL-3.1 WITH NJOY2012.50+
resonance absorption cross sections

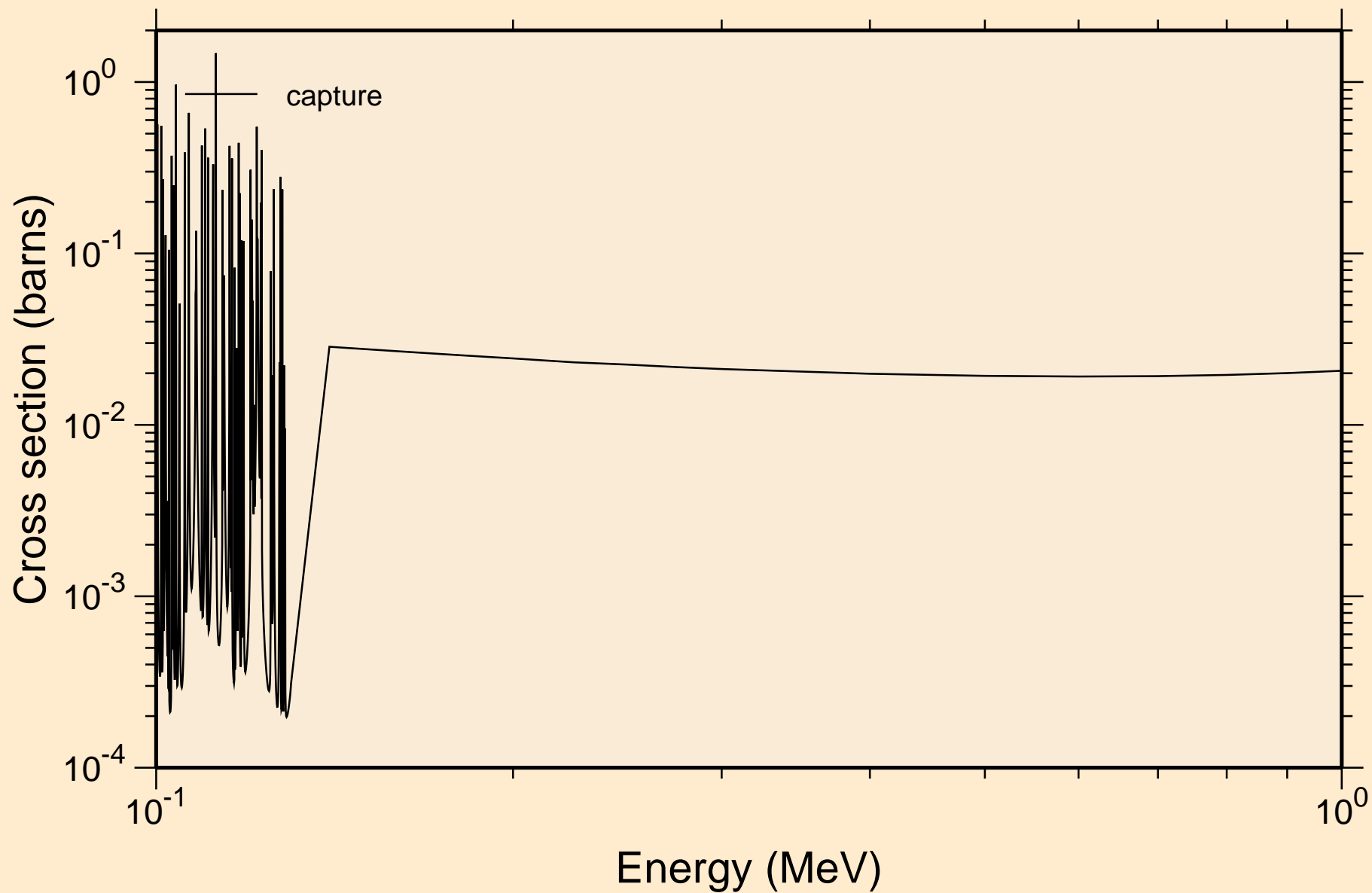

30-ZN-64 FOR FENDL-3.1 FROM FENDL-3.1 WITH NJOY2012.50+
resonance absorption cross sections

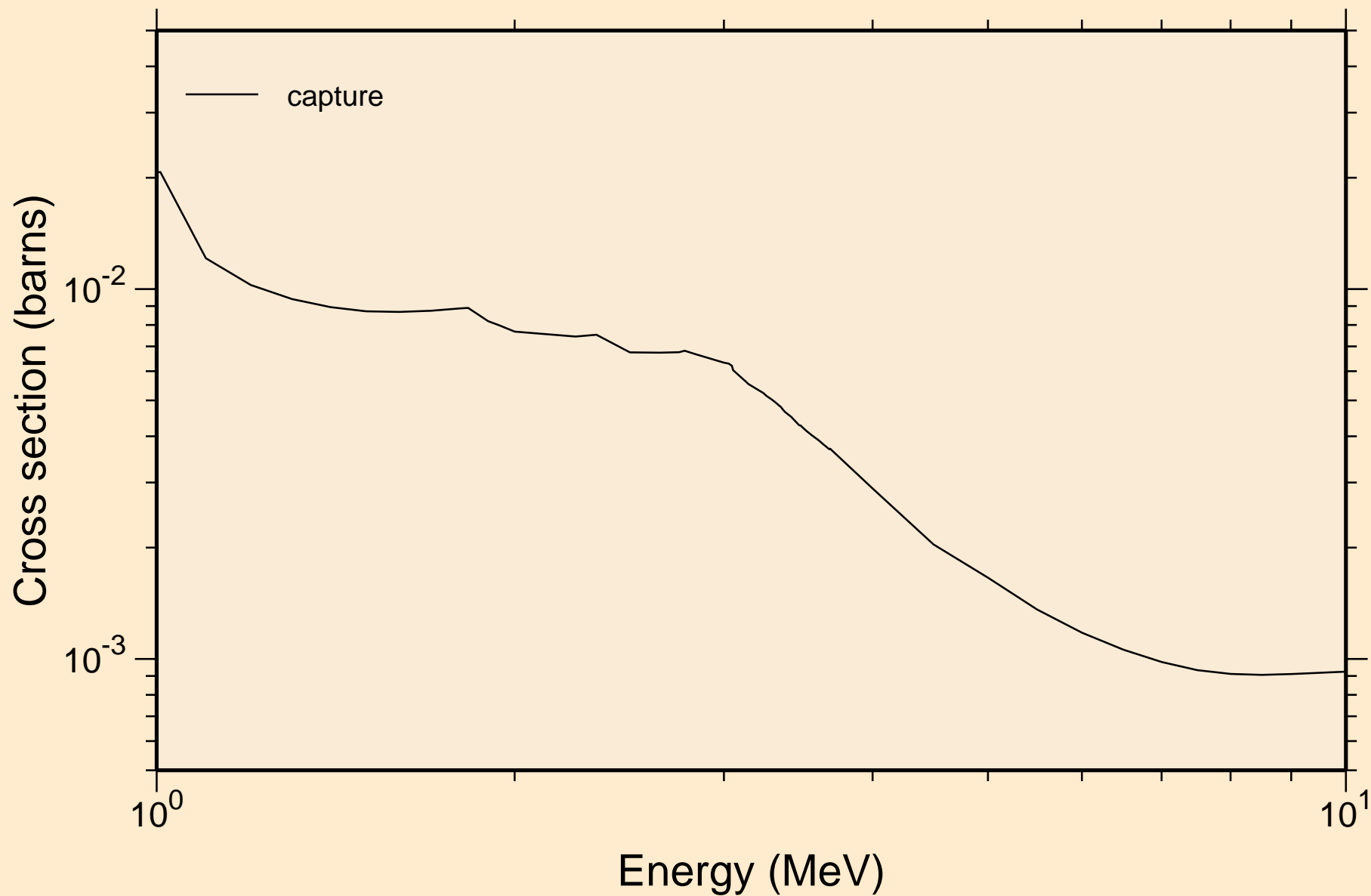

30-ZN-64 FOR FENDL-3.1 FROM FENDL-3.1 WITH NJOY2012.50+
UR total cross section

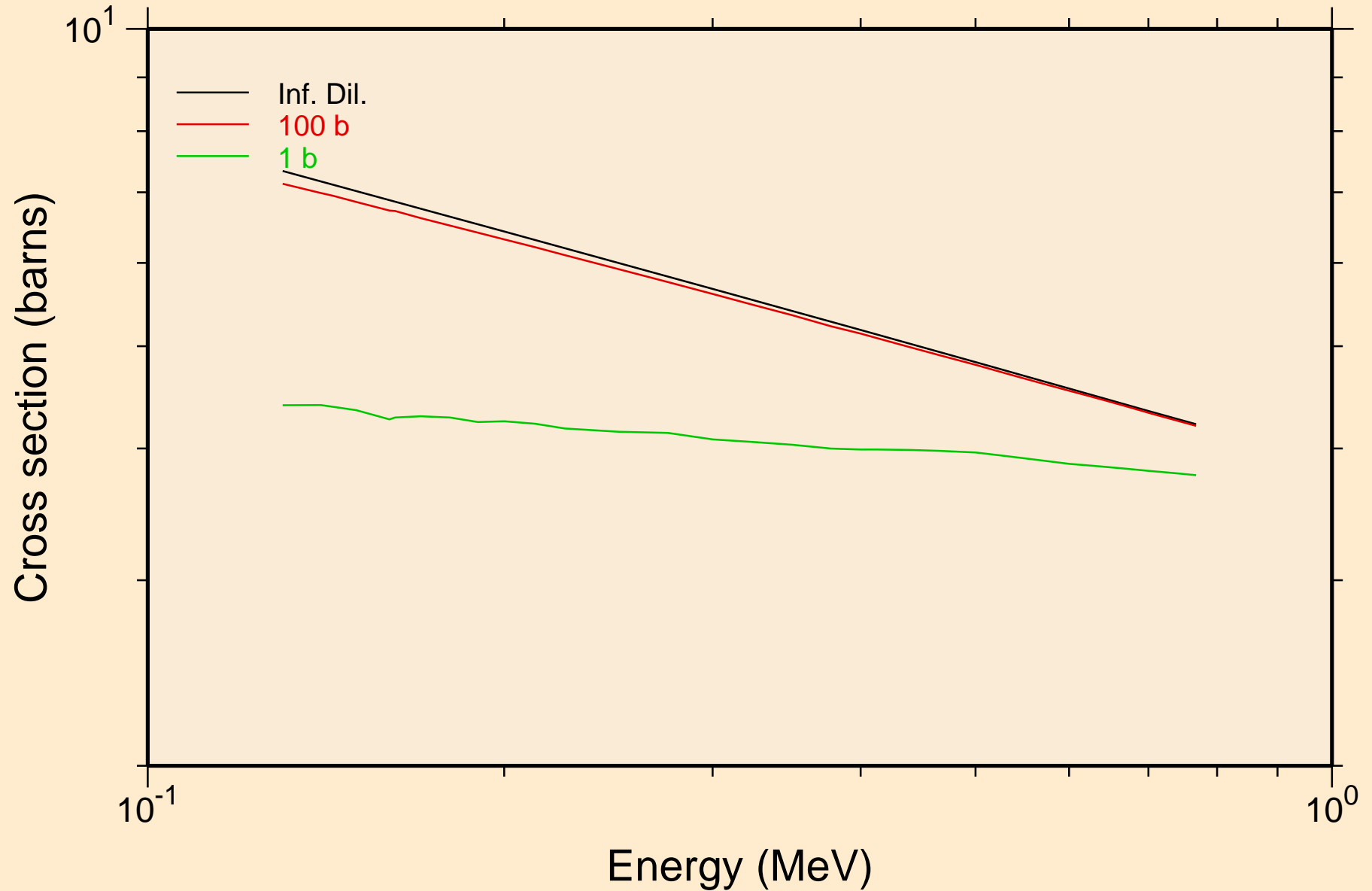

30-ZN-64 FOR FENDL-3.1 FROM FENDL-3.1 WITH NJOY2012.50+
UR elastic cross section

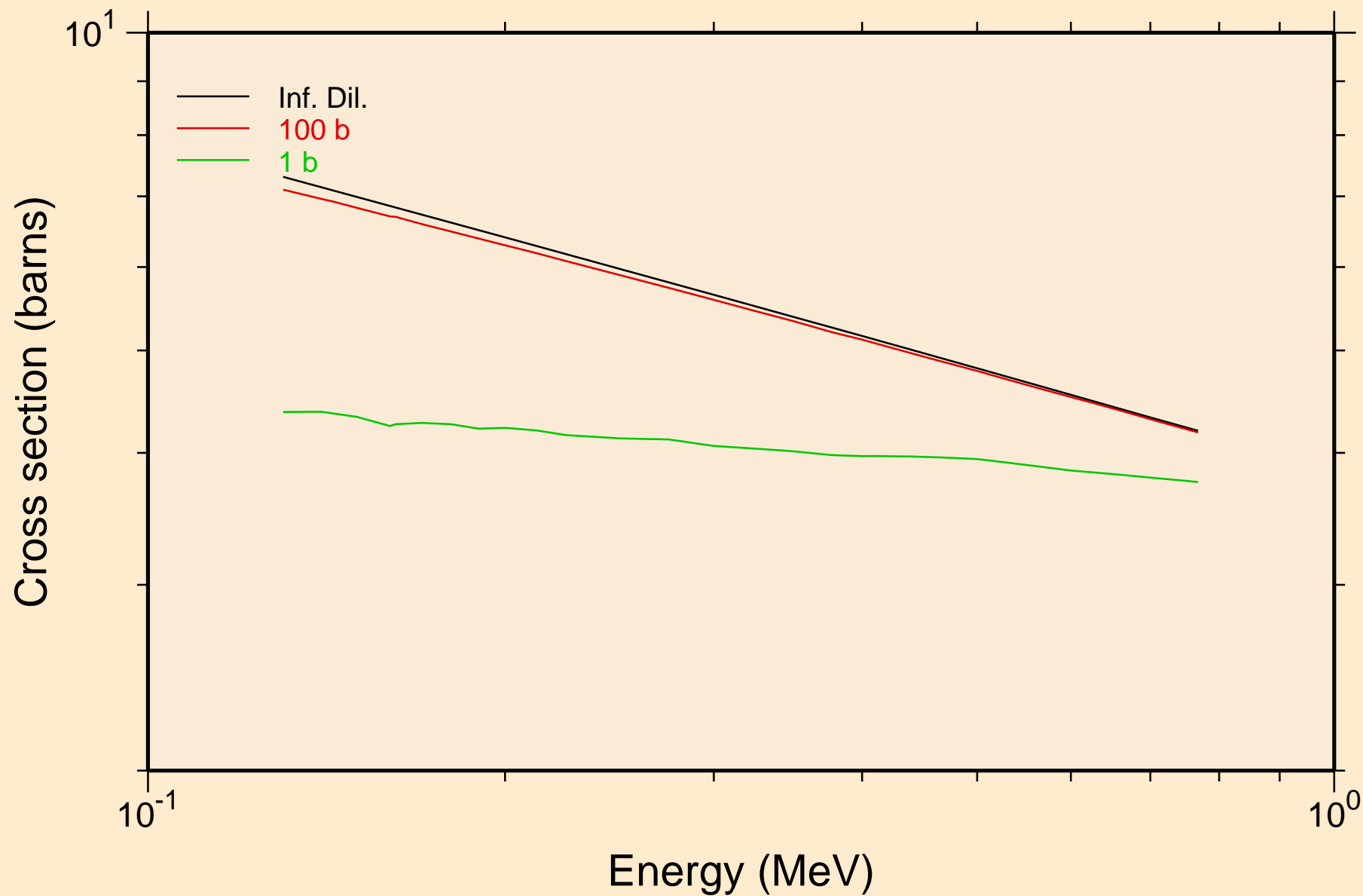

30-ZN-64 FOR FENDL-3.1 FROM FENDL-3.1 WITH NJOY2012.50+
UR capture cross section

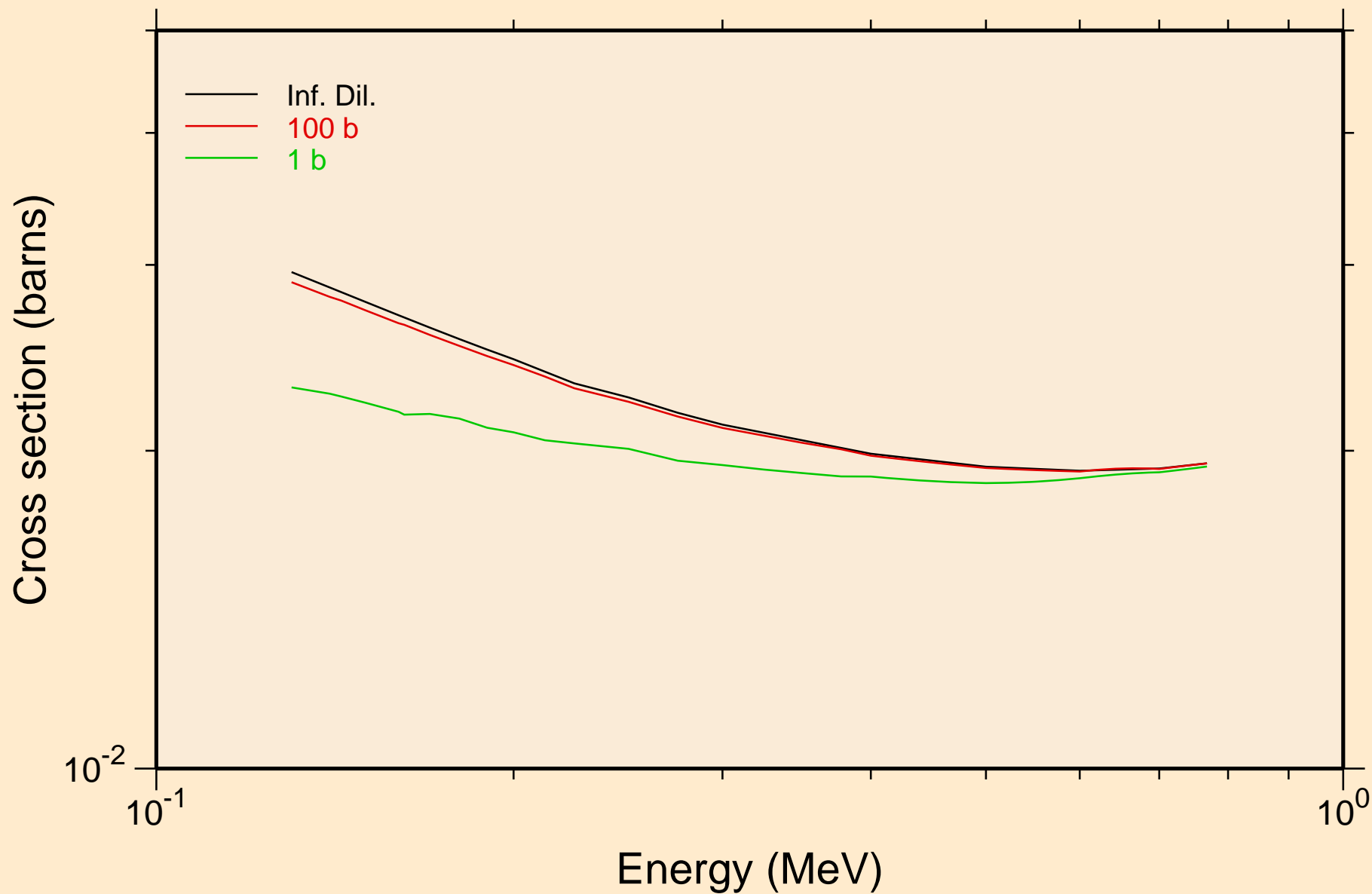

30-ZN-64 FOR FENDL-3.1 FROM FENDL-3.1 WITH NJOY2012.50+ Heating

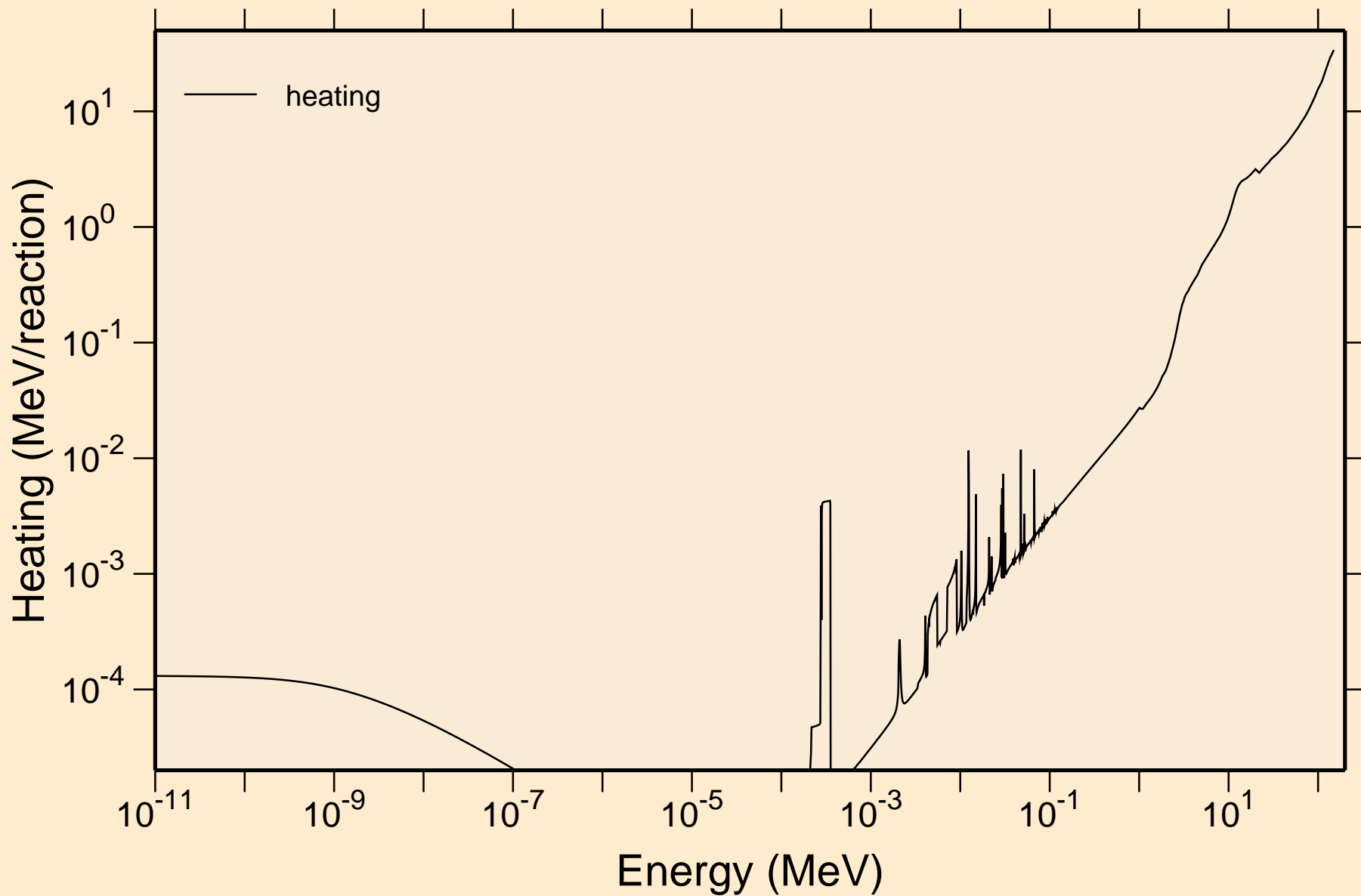

30-ZN-64 FOR FENDL-3.1 FROM FENDL-3.1 WITH NJOY2012.50+ Damage

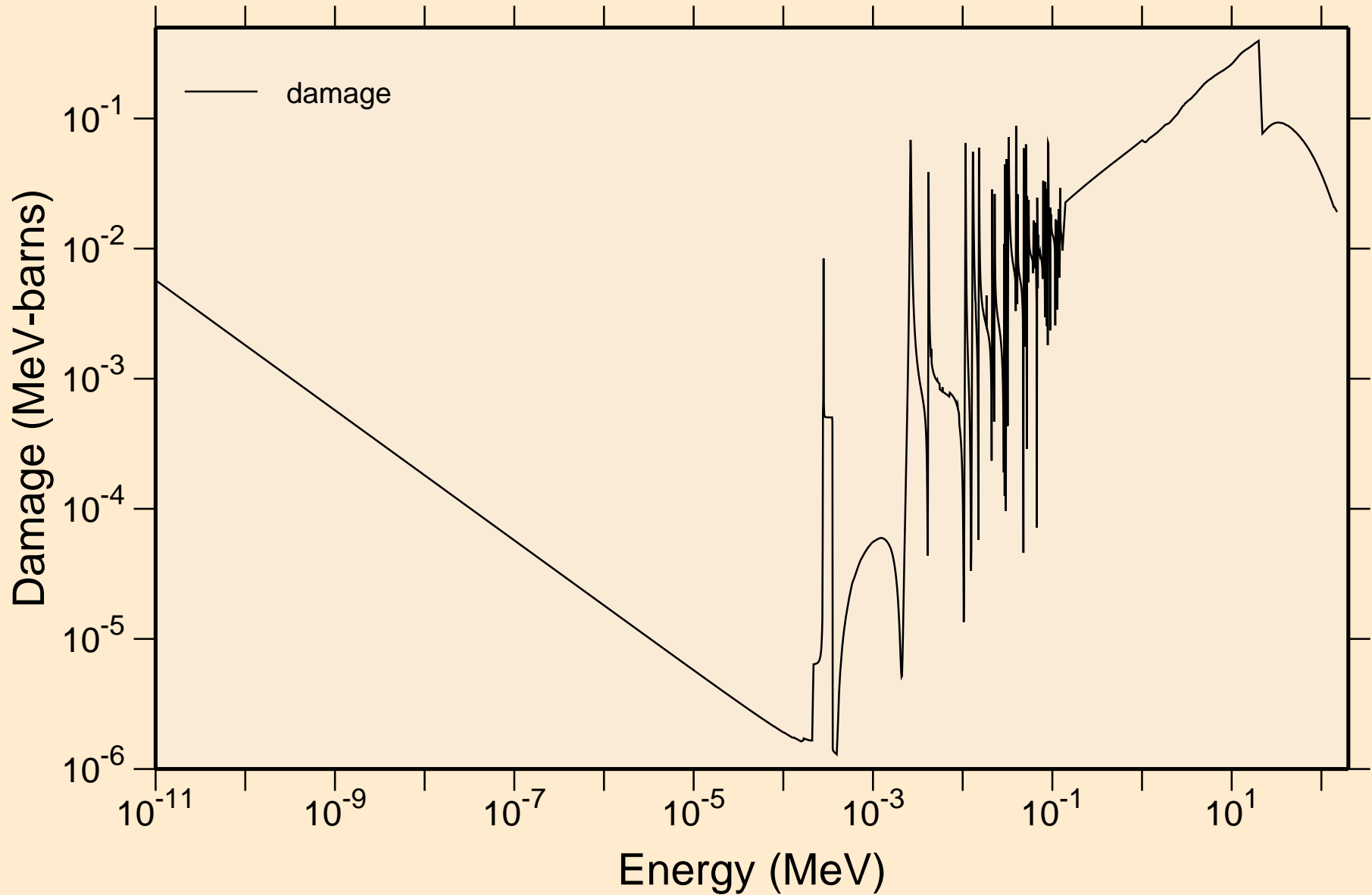

30-ZN-64 FOR FENDL-3.1 FROM FENDL-3.1 WITH NJOY2012.50+
Non-threshold reactions

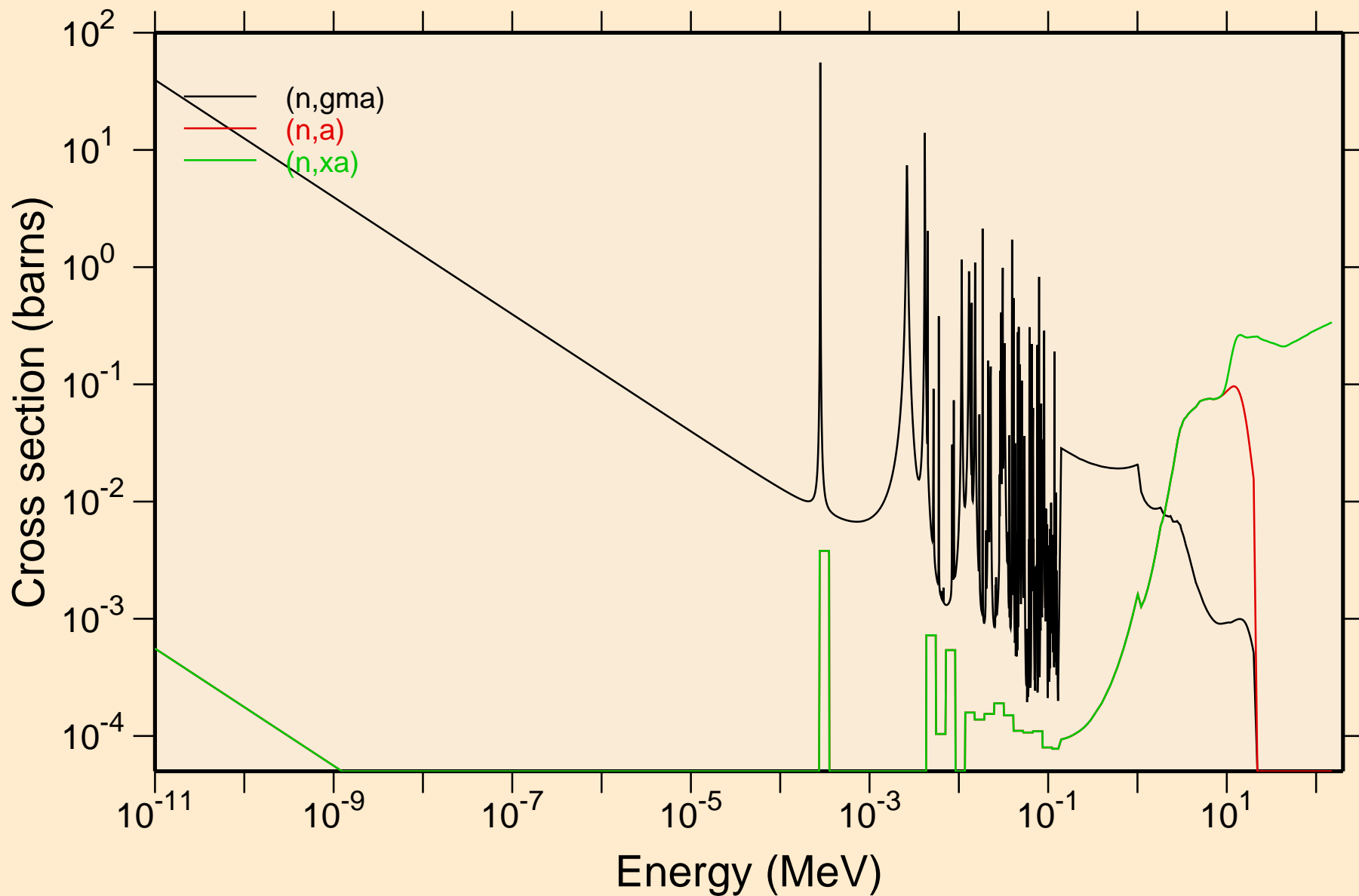

30-ZN-64 FOR FENDL-3.1 FROM FENDL-3.1 WITH NJOY2012.50+

Principal cross sections

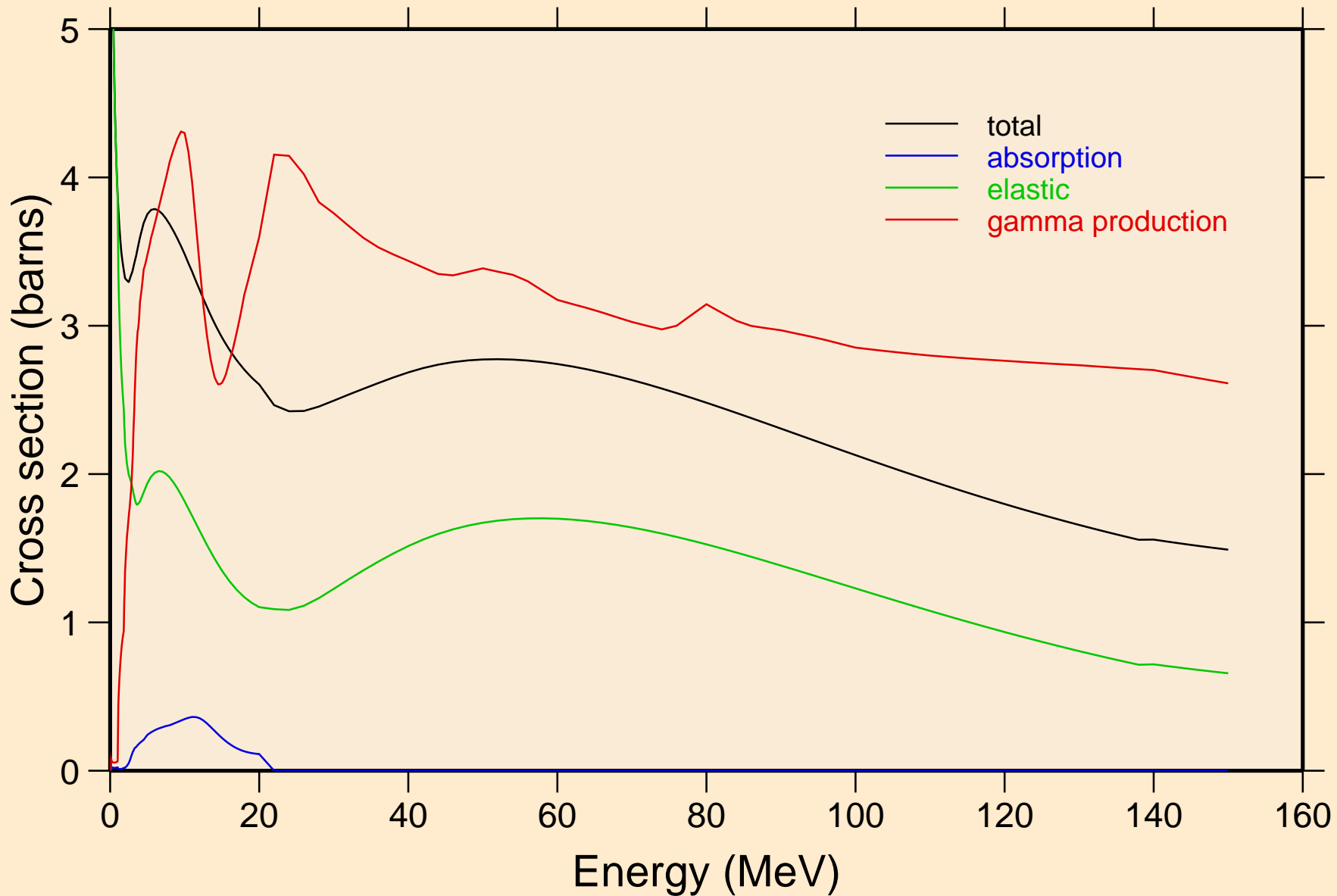

30-ZN-64 FOR FENDL-3.1 FROM FENDL-3.1 WITH NJOY2012.50+ Heating

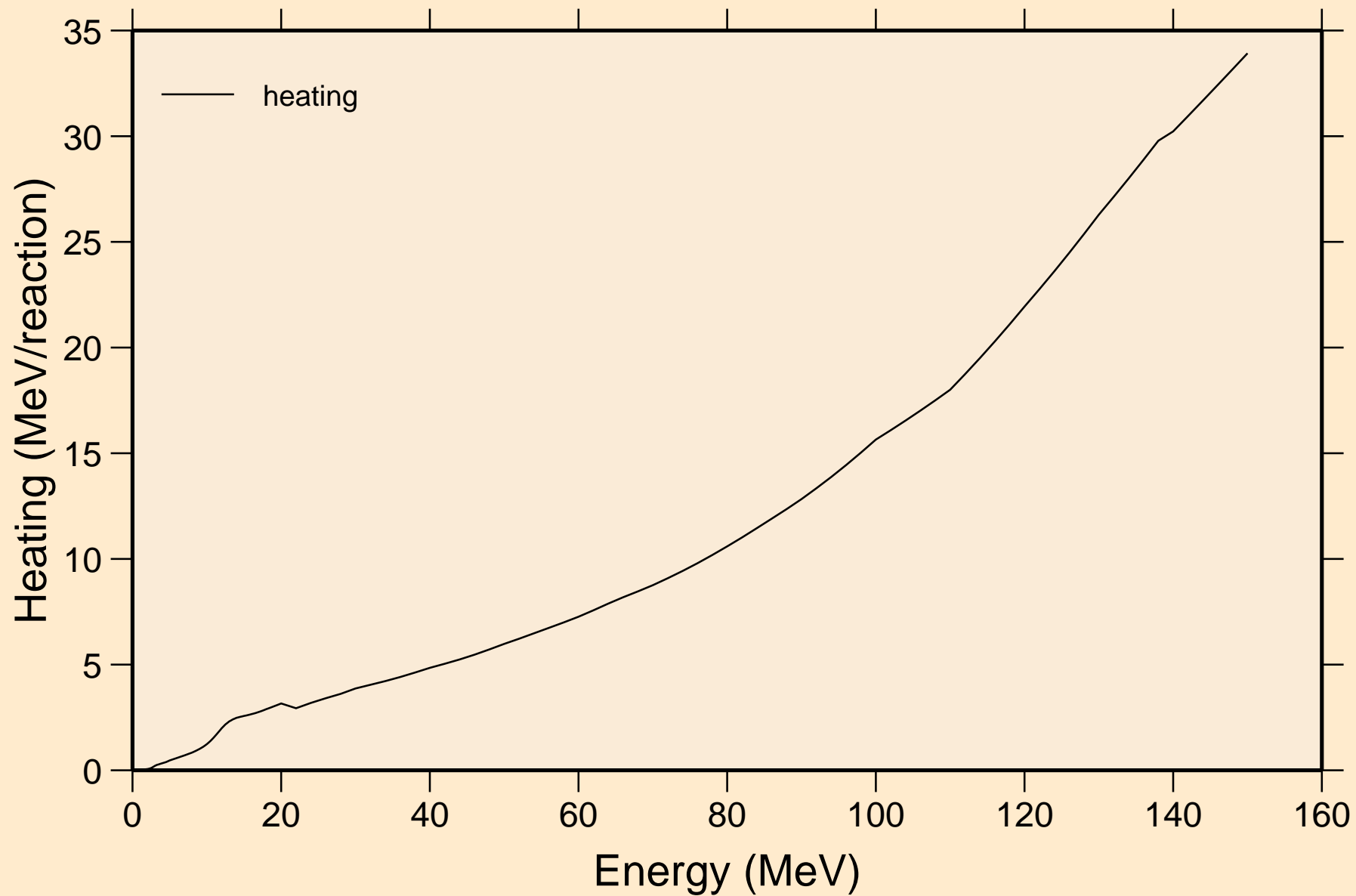

30-ZN-64 FOR FENDL-3.1 FROM FENDL-3.1 WITH NJOY2012.50+ Damage

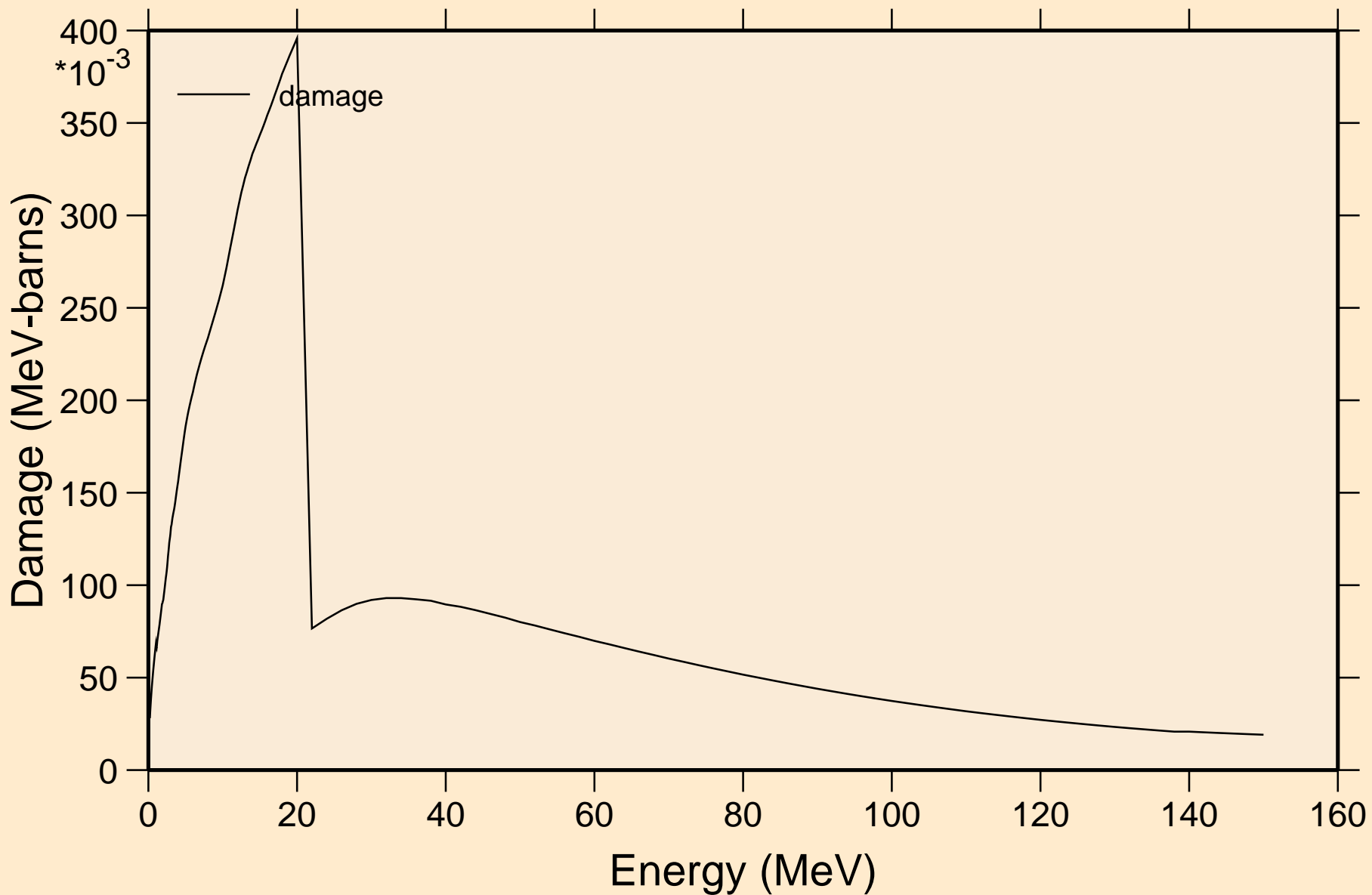

30-ZN-64 FOR FENDL-3.1 FROM FENDL-3.1 WITH NJOY2012.50+
Non-threshold reactions

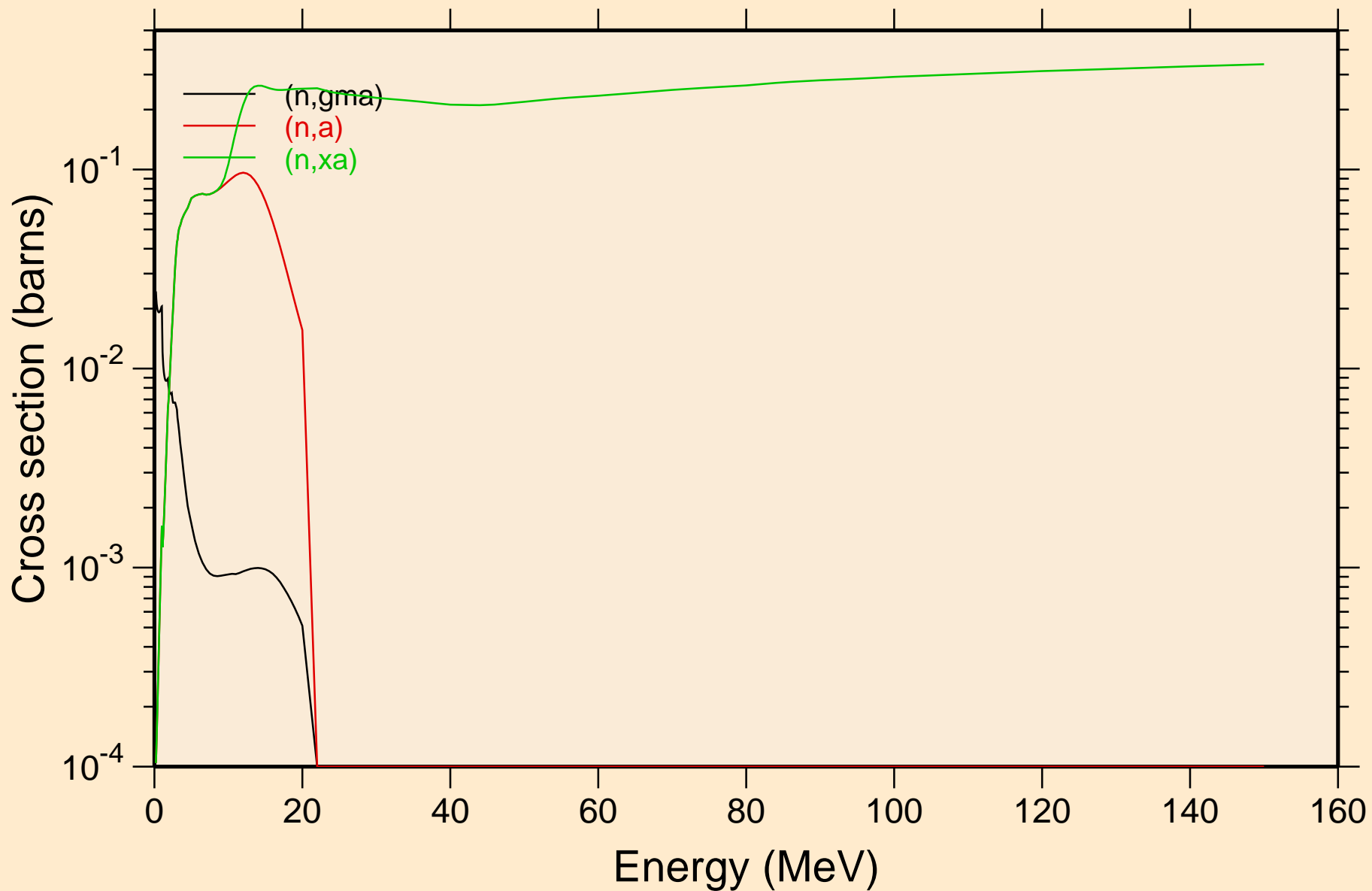

30-ZN-64 FOR FENDL-3.1 FROM FENDL-3.1 WITH NJOY2012.50+ Inelastic levels

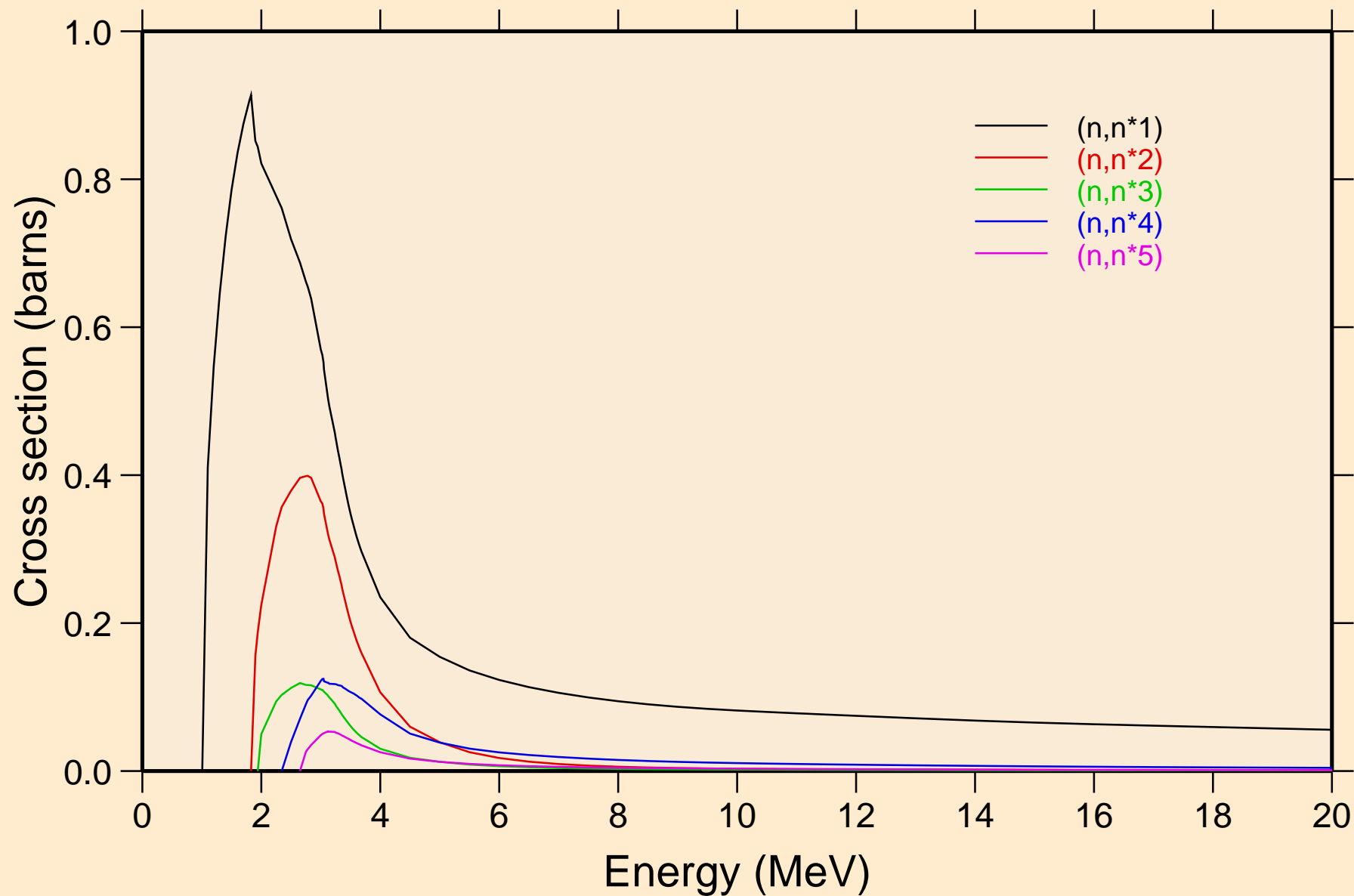

30-ZN-64 FOR FENDL-3.1 FROM FENDL-3.1 WITH NJOY2012.50+ Inelastic levels

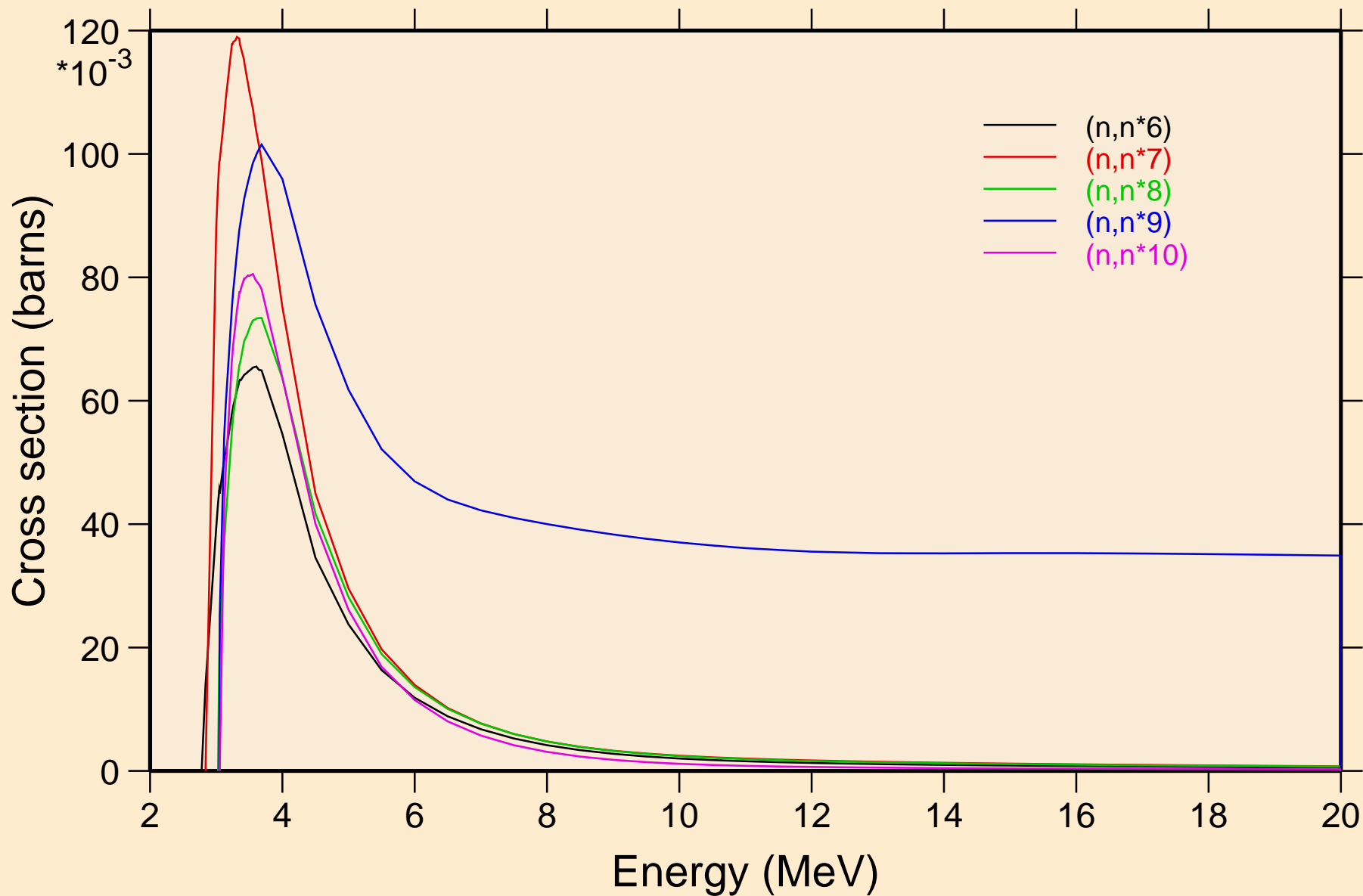

30-ZN-64 FOR FENDL-3.1 FROM FENDL-3.1 WITH NJOY2012.50+
Inelastic levels

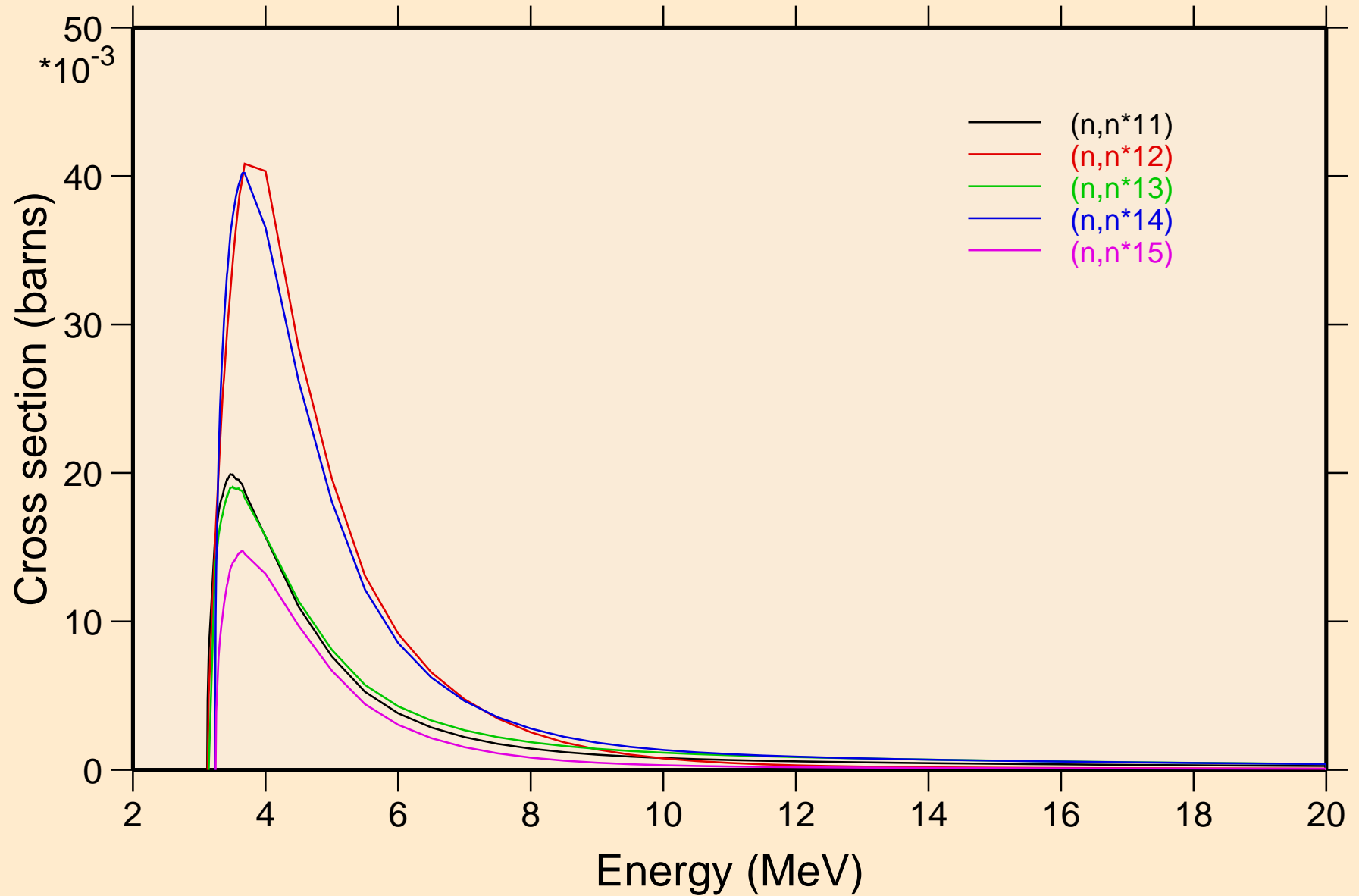

30-ZN-64 FOR FENDL-3.1 FROM FENDL-3.1 WITH NJOY2012.50+
Inelastic levels

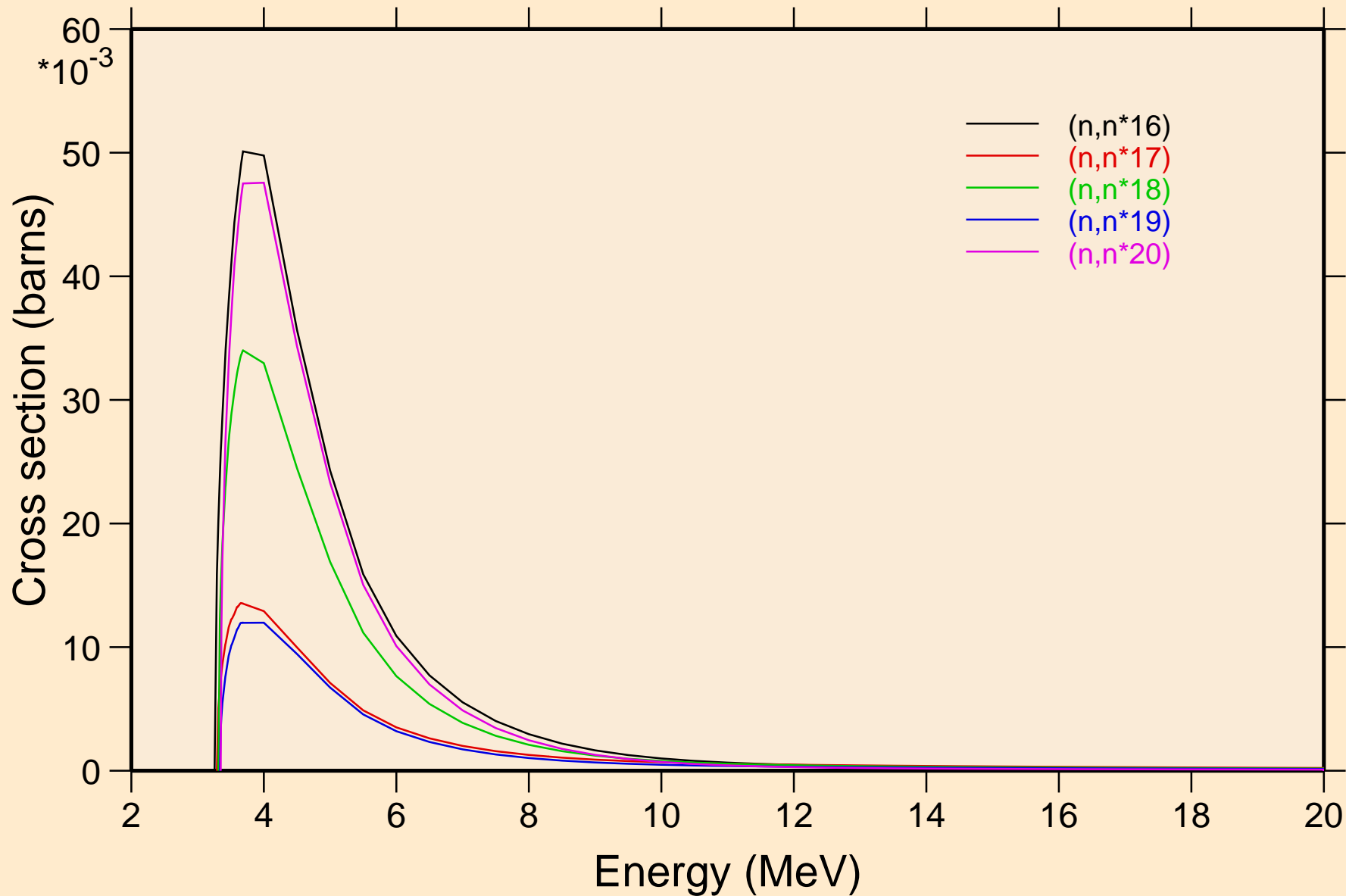

30-ZN-64 FOR FENDL-3.1 FROM FENDL-3.1 WITH NJOY2012.50+ Inelastic levels

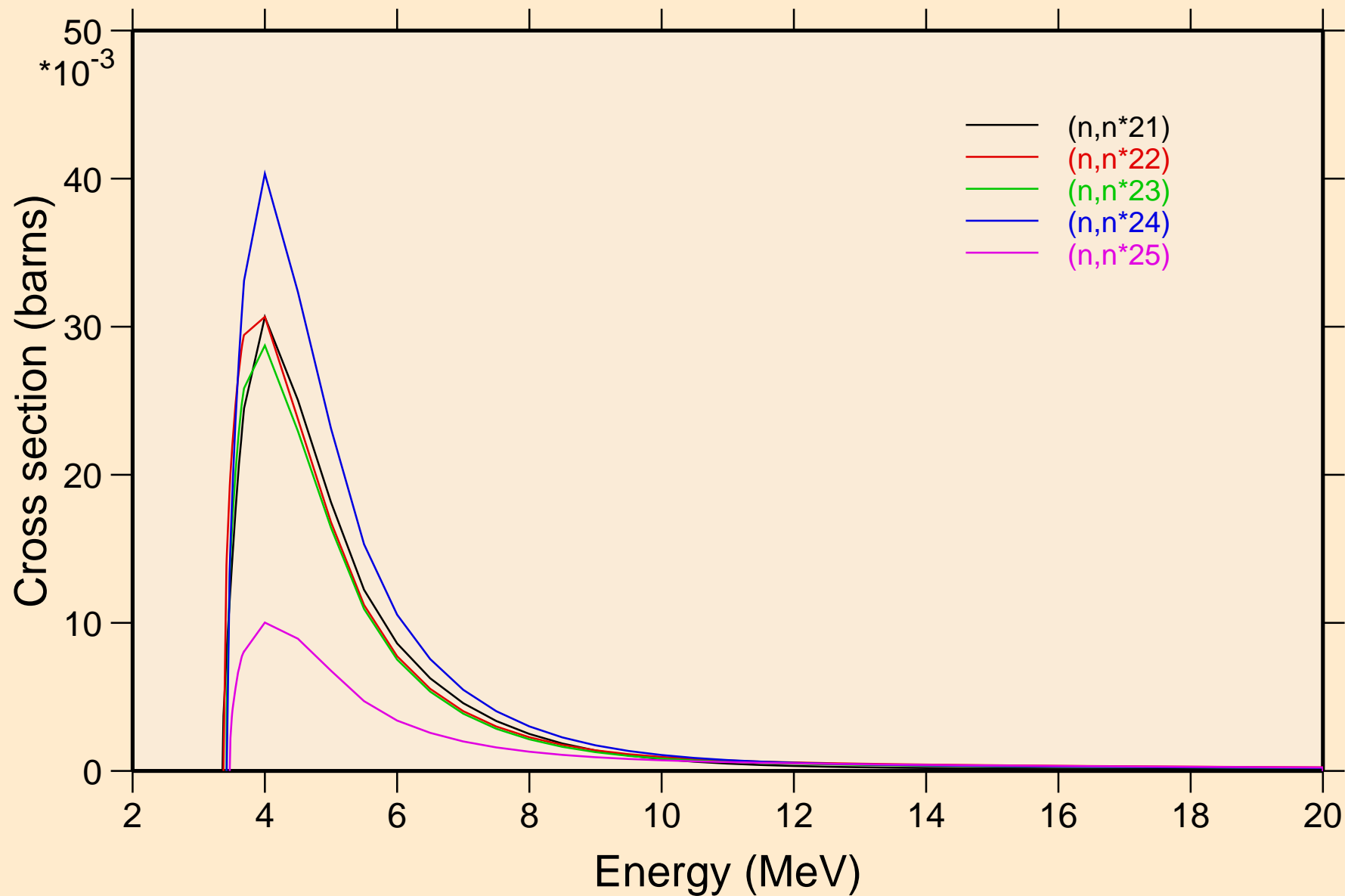

30-ZN-64 FOR FENDL-3.1 FROM FENDL-3.1 WITH NJOY2012.50+
Inelastic levels

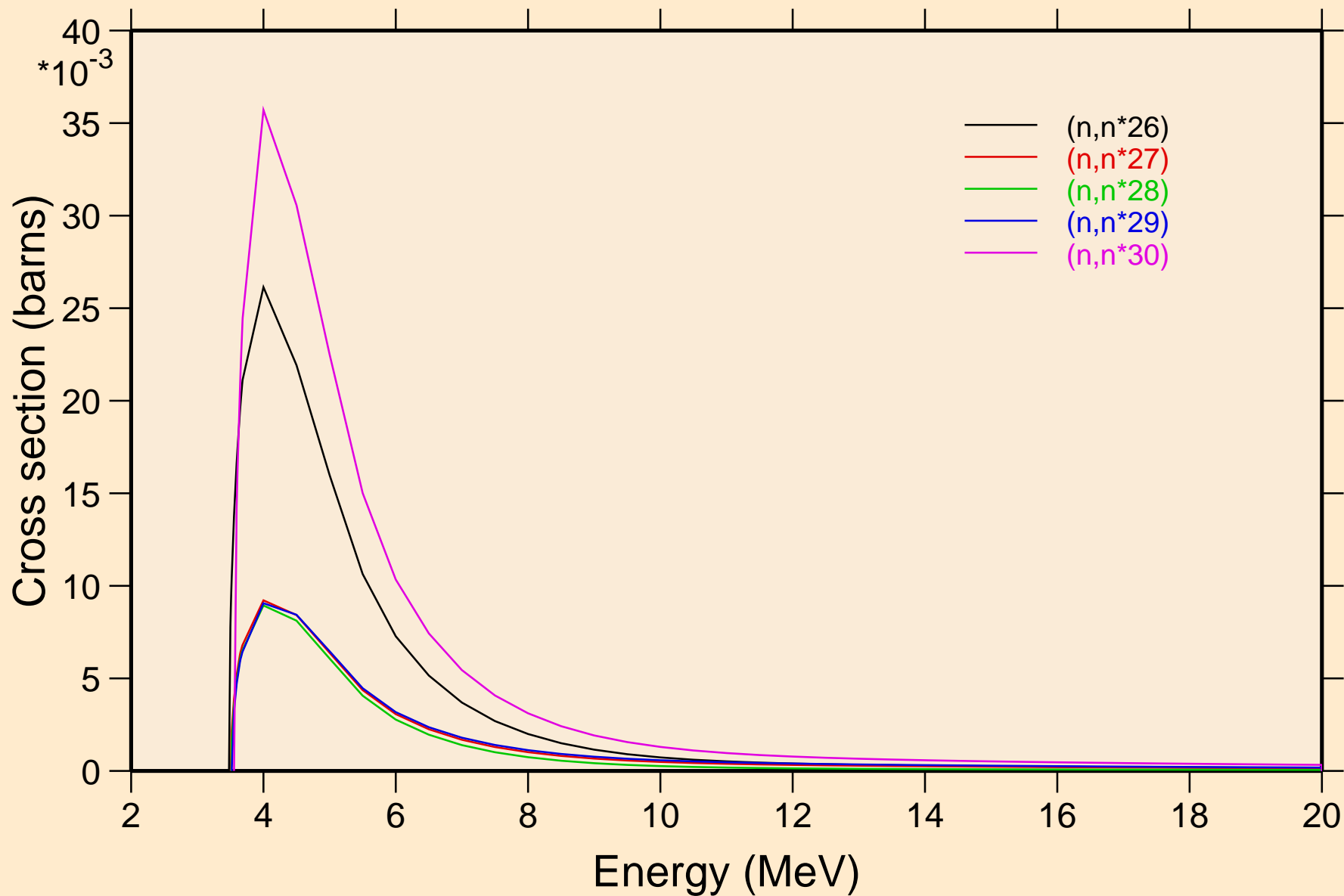

30-ZN-64 FOR FENDL-3.1 FROM FENDL-3.1 WITH NJOY2012.50+
Inelastic levels

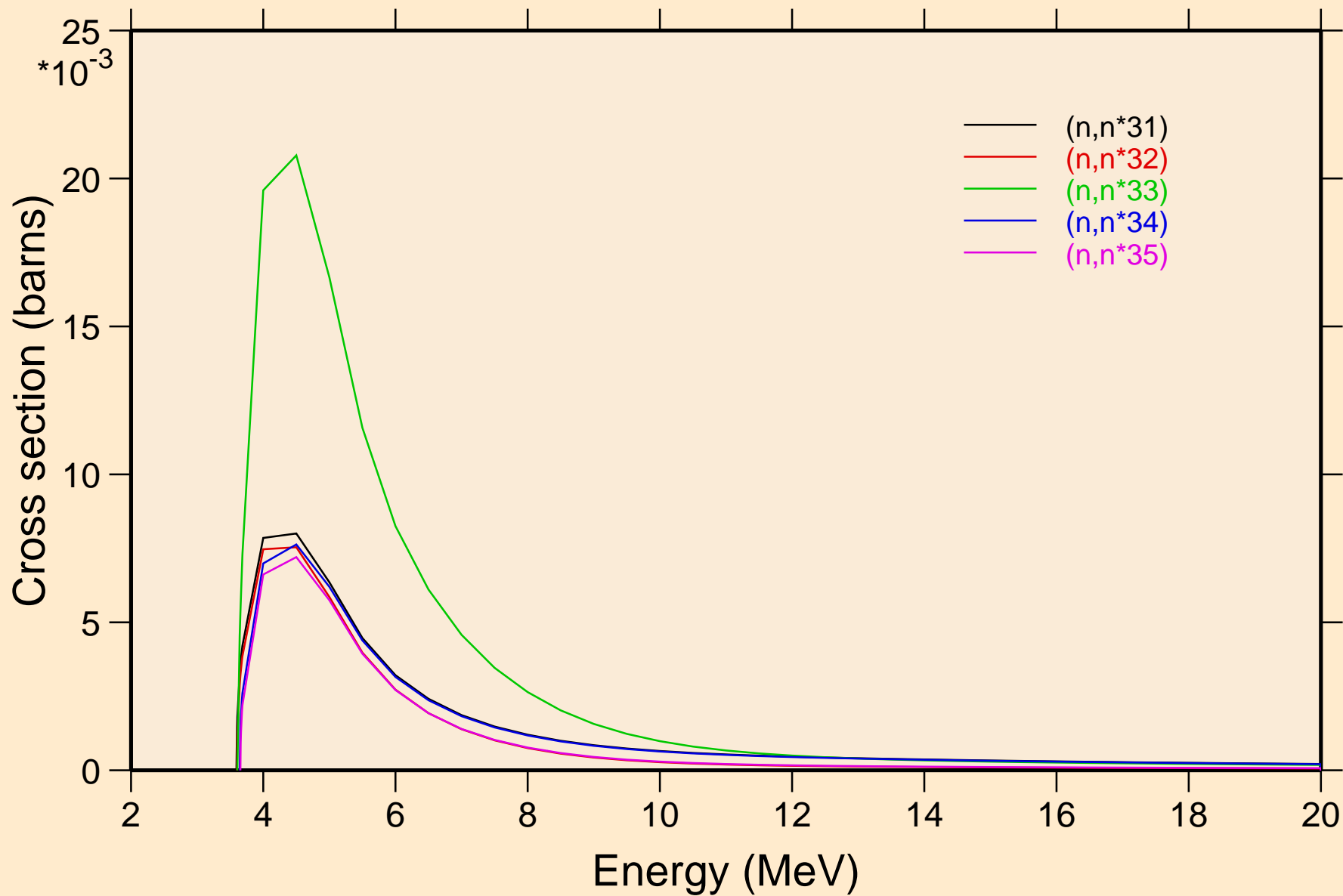

30-ZN-64 FOR FENDL-3.1 FROM FENDL-3.1 WITH NJOY2012.50+
Inelastic levels

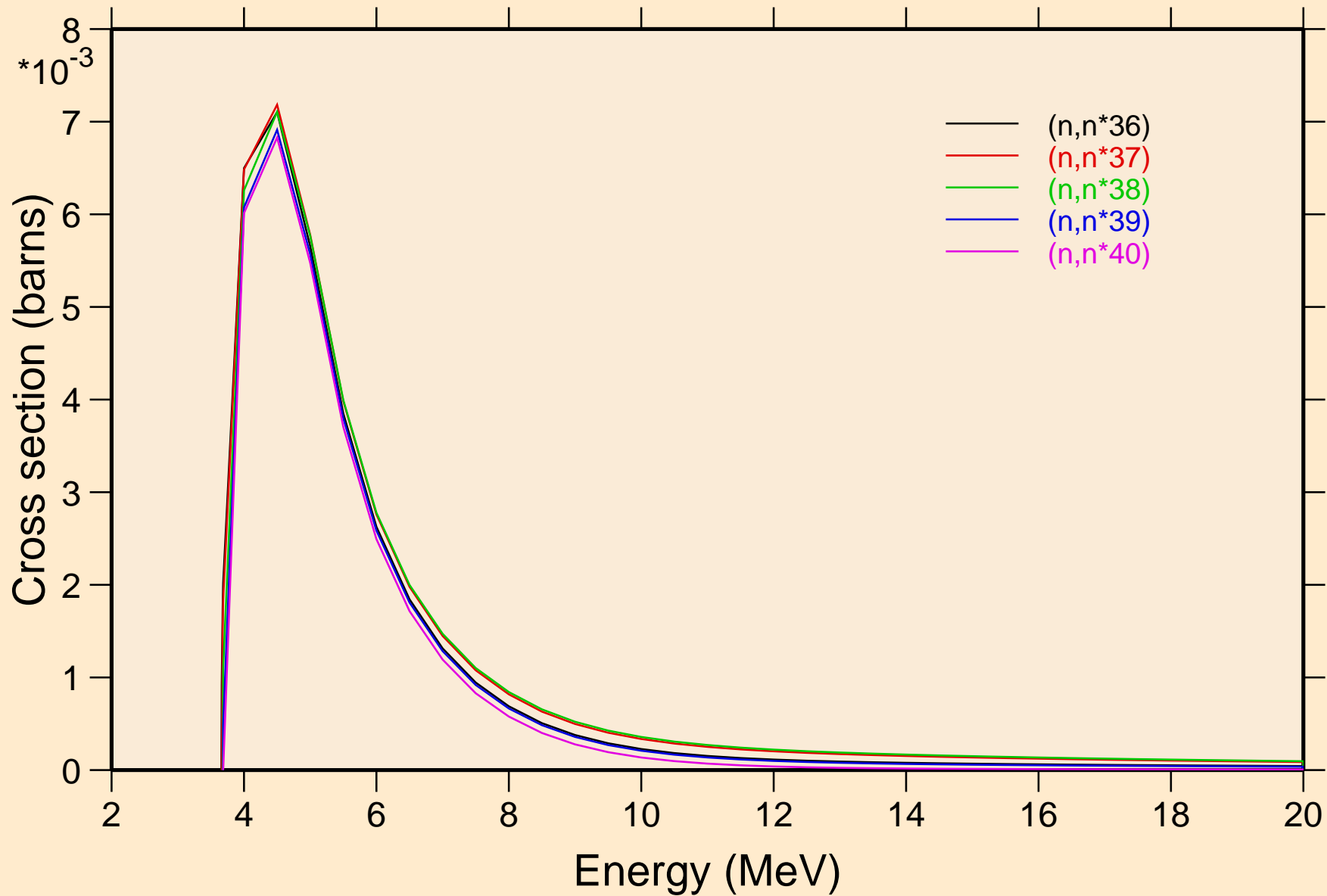

30-ZN-64 FOR FENDL-3.1 FROM FENDL-3.1 WITH NJOY2012.50+
Threshold reactions

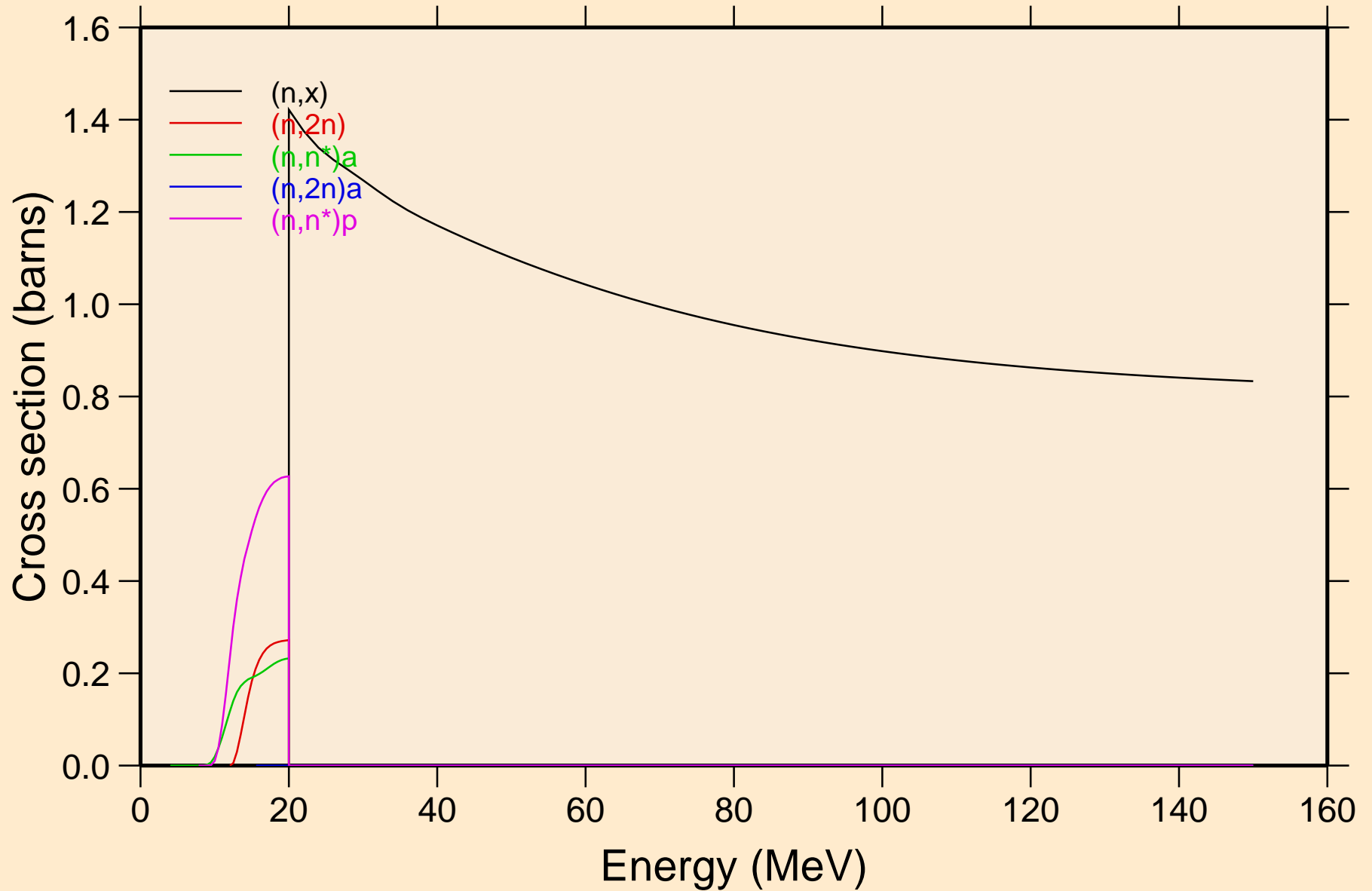

30-ZN-64 FOR FENDL-3.1 FROM FENDL-3.1 WITH NJOY2012.50+
Threshold reactions

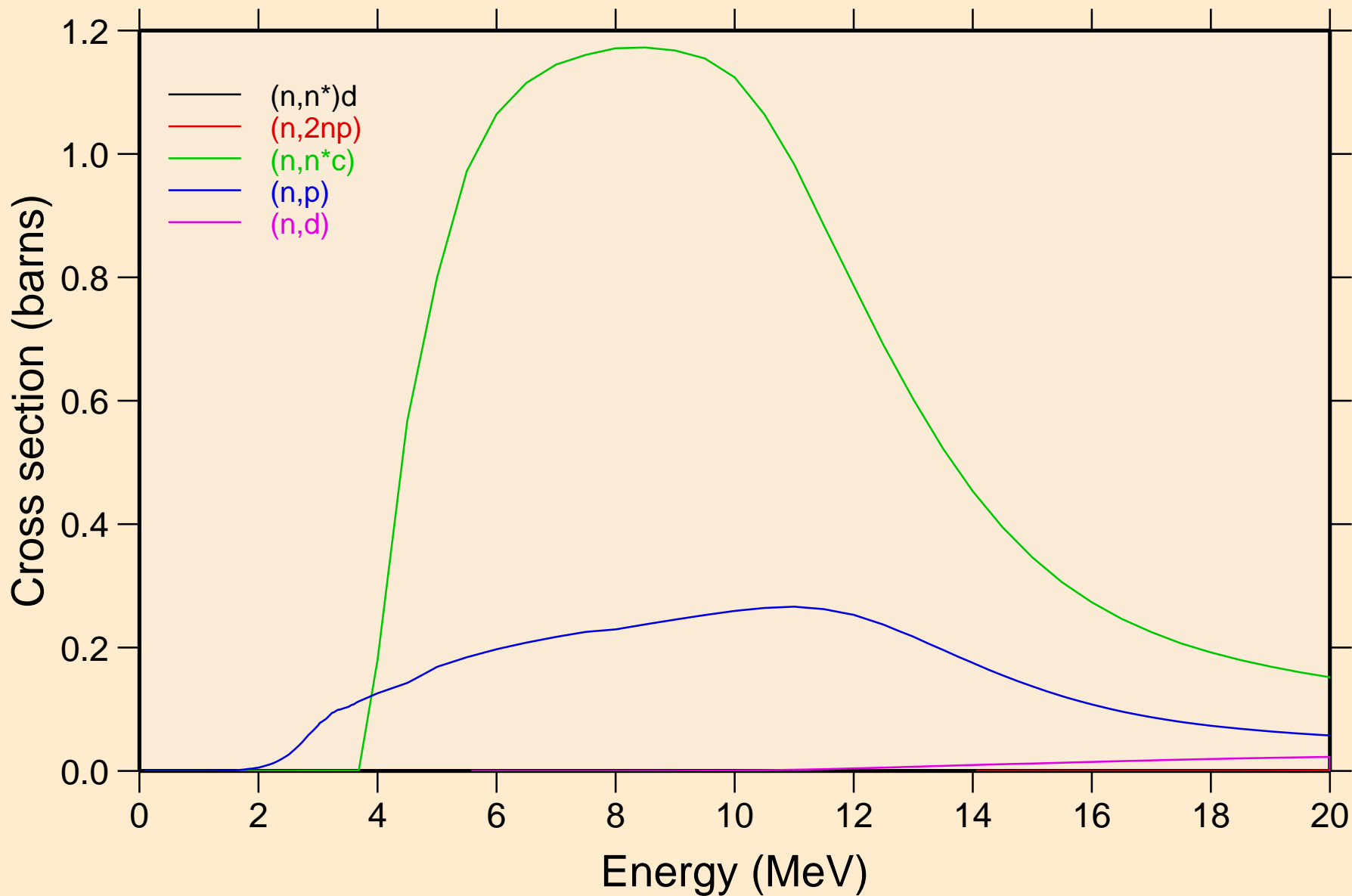

30-ZN-64 FOR FENDL-3.1 FROM FENDL-3.1 WITH NJOY2012.50+
Threshold reactions

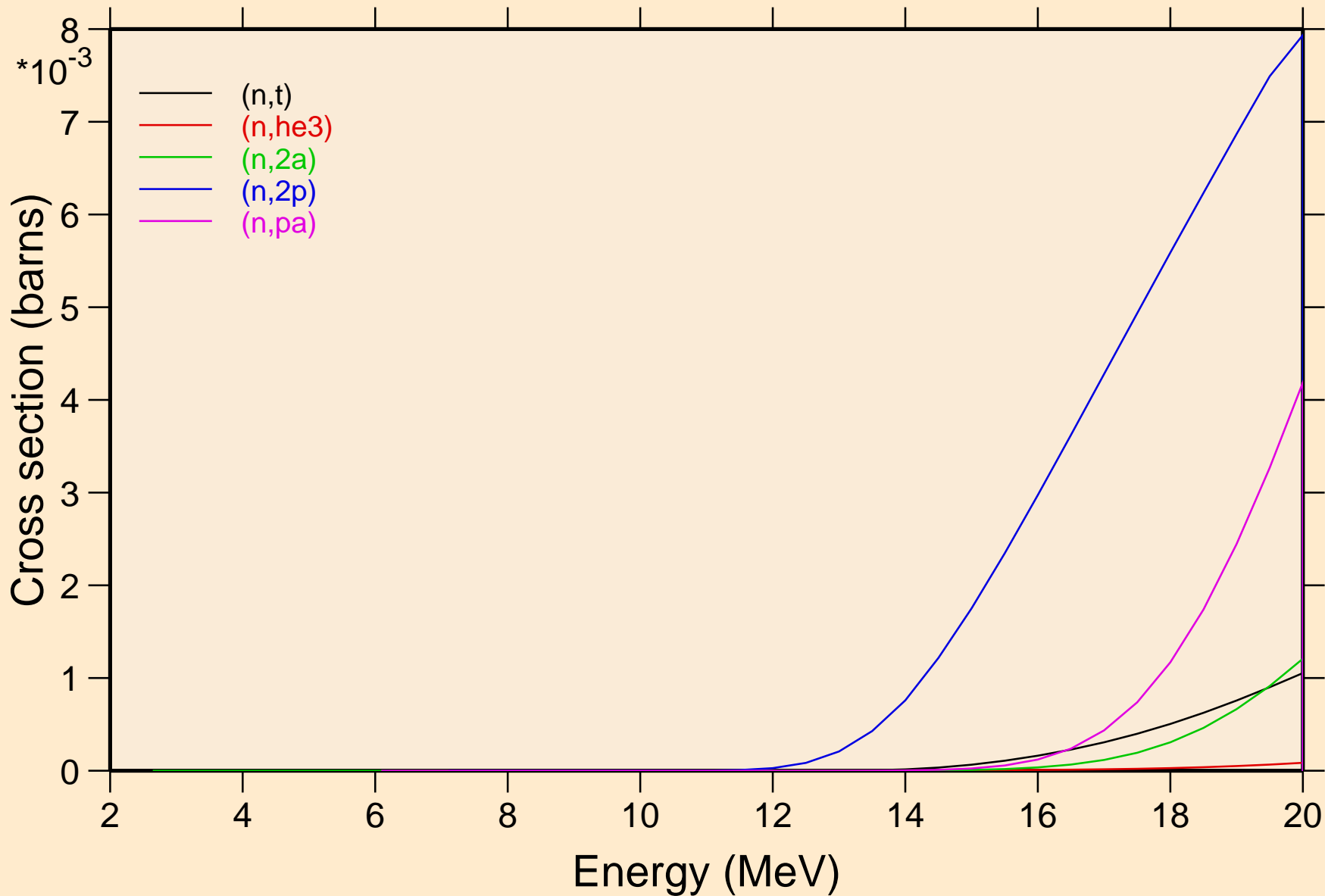

30-ZN-64 FOR FENDL-3.1 FROM FENDL-3.1 WITH NJOY2012.50+
Threshold reactions

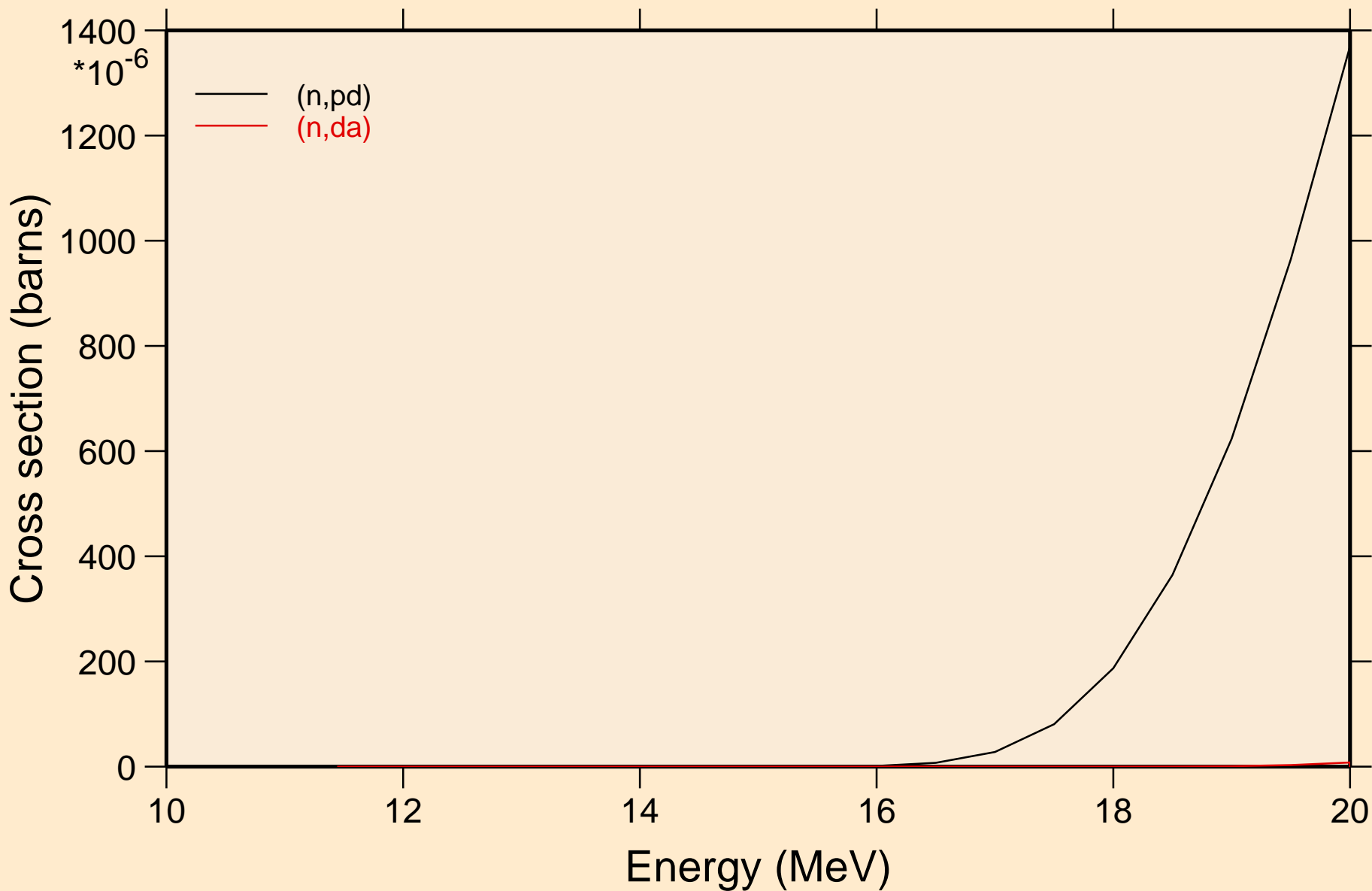

30-ZN-64 FOR FENDL-3.1 FROM FENDL-3.1 WITH NJOY2012.50+ Threshold reactions

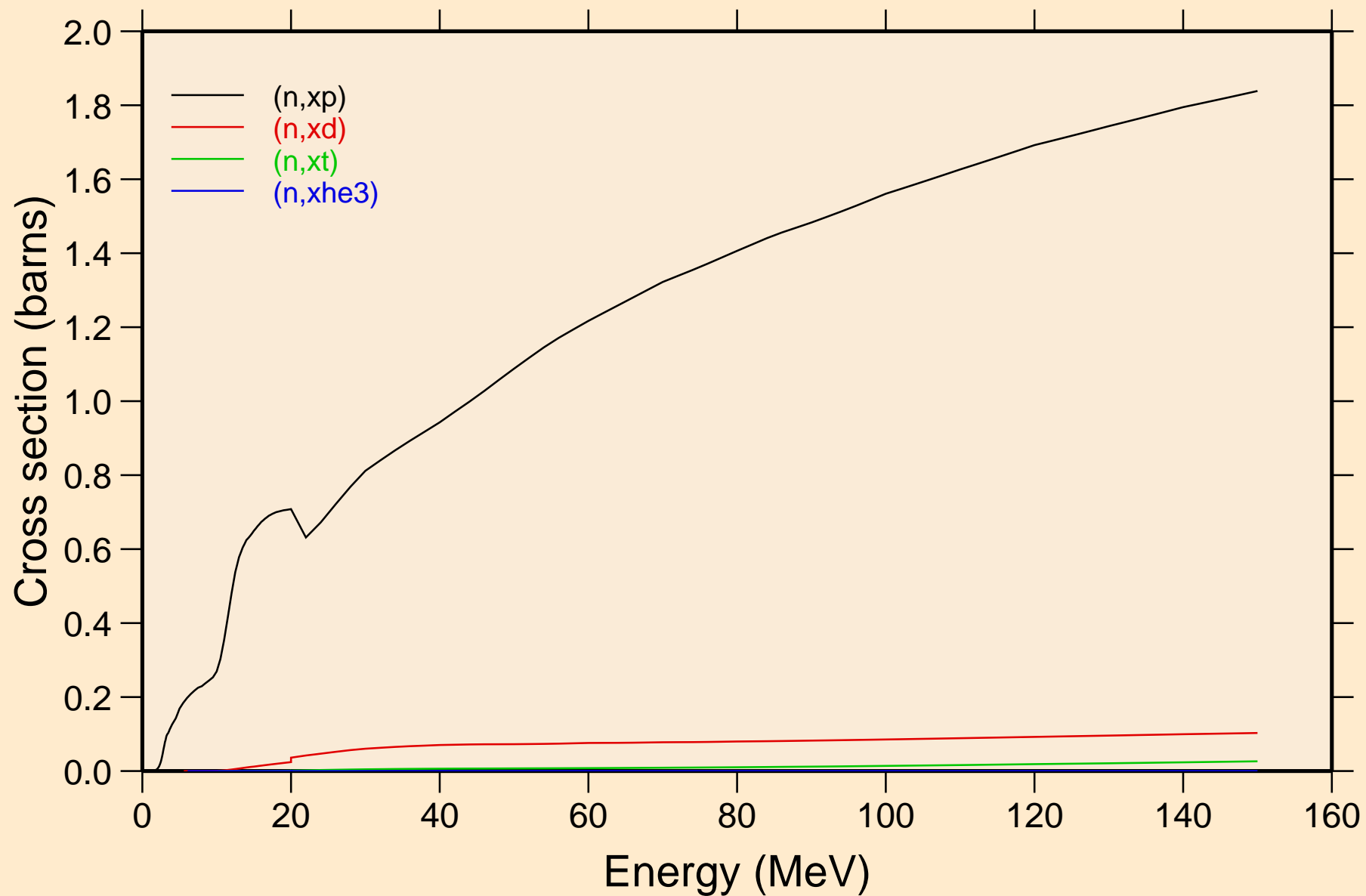

30-ZN-64 FOR FENDL-3.1 FROM FENDL-3.1 WITH NJOY2012.50+
angular distribution for elastic

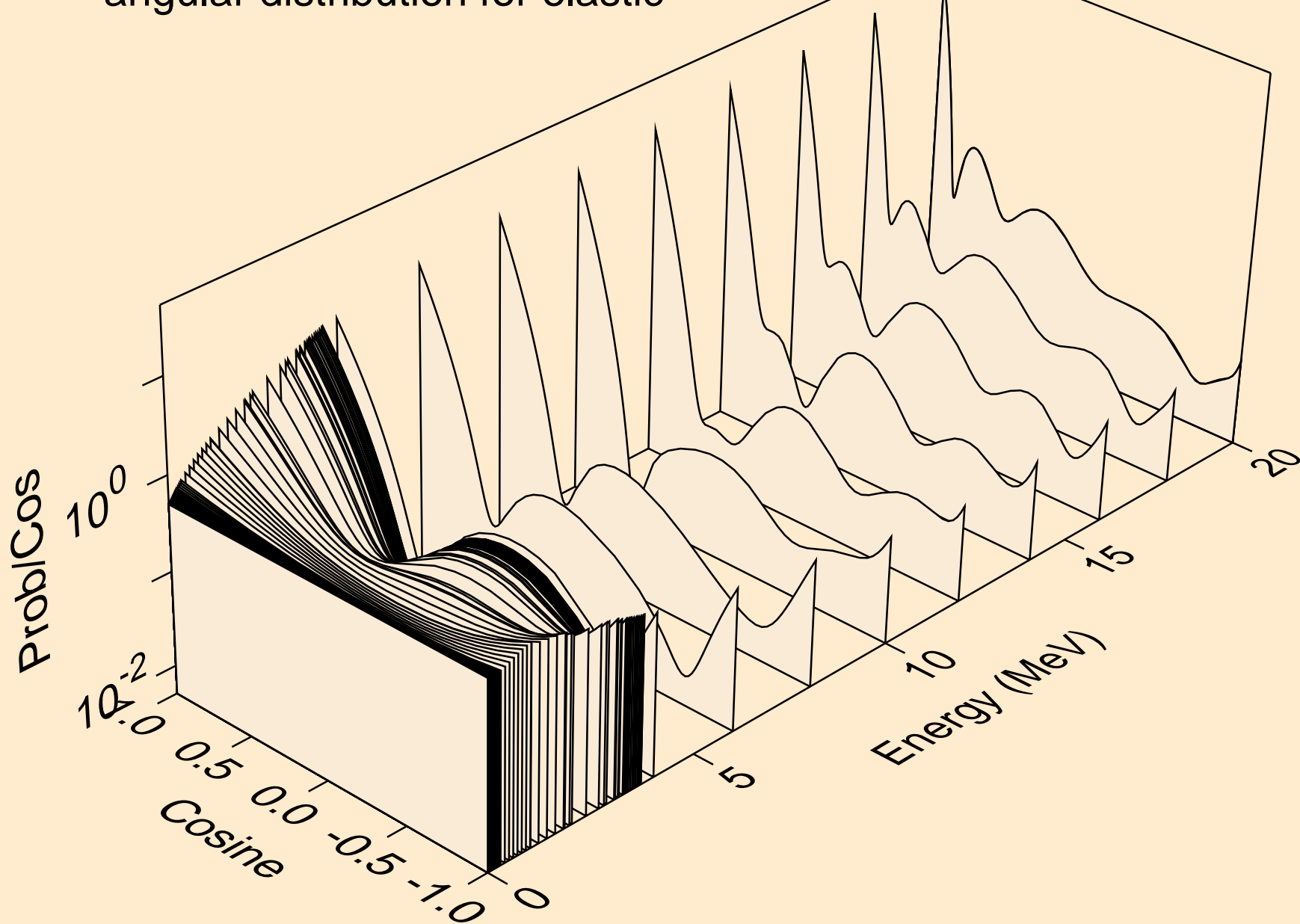

30-ZN-64 FOR FENDL-3.1 FROM FENDL-3.1 WITH NJOY2012.50+
angular distribution for elastic

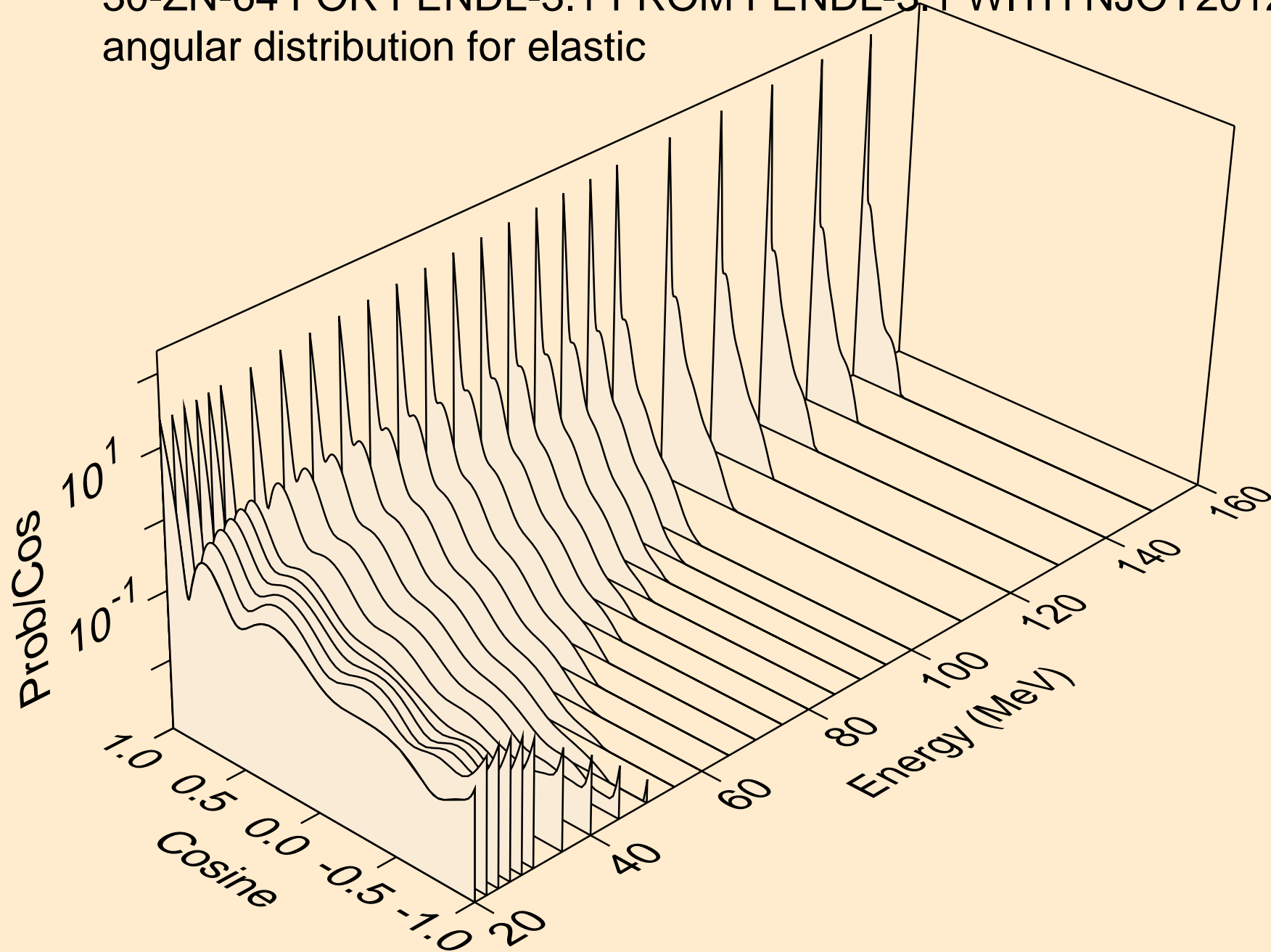

30-ZN-64 FOR FENDL-3.1 FROM FENDL-3.1 WITH NJOY2012.50+
angular distribution for (n,n*1)

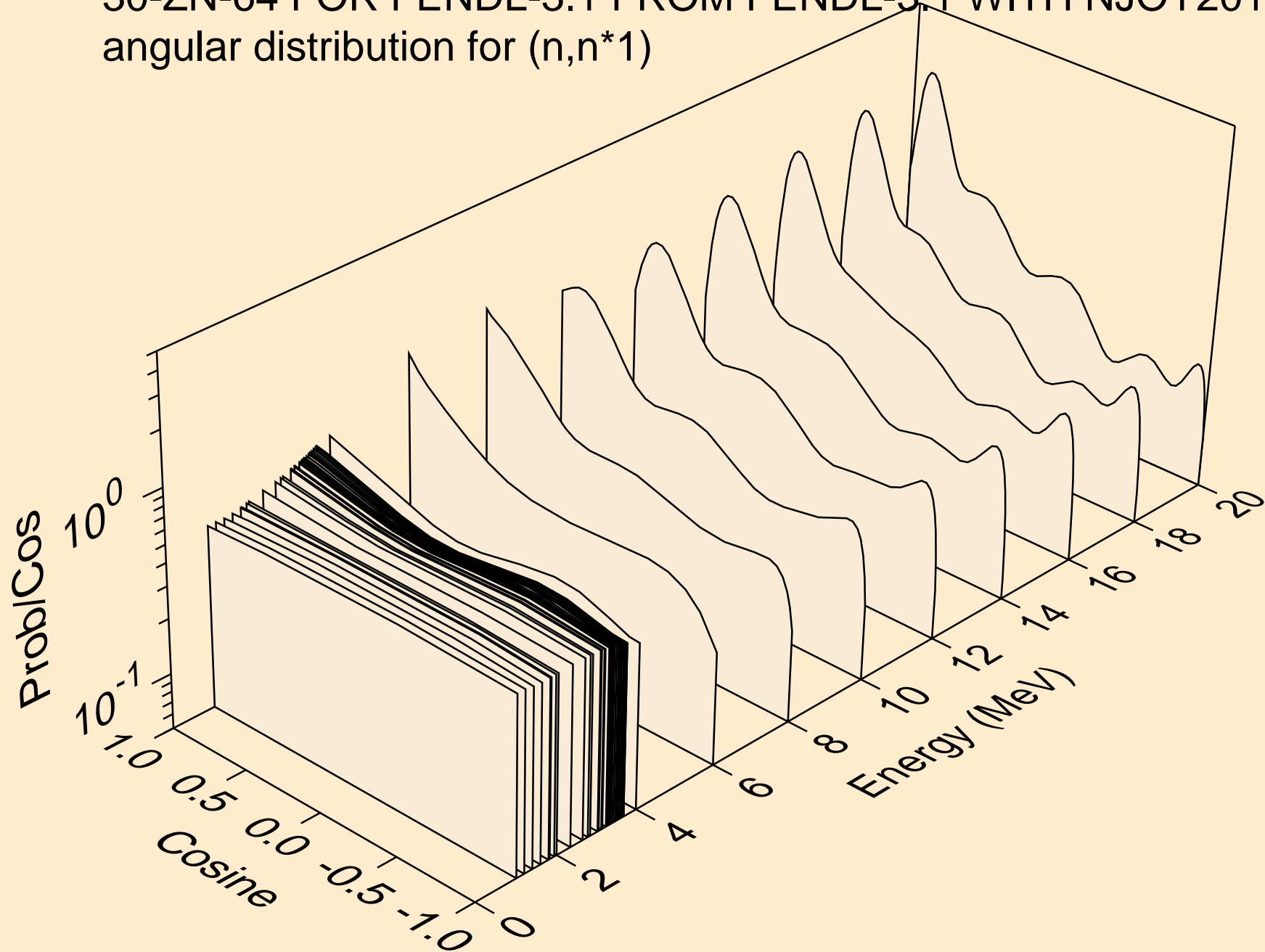

30-ZN-64 FOR FENDL-3.1 FROM FENDL-3.1 WITH NJOY2012.50+
angular distribution for (n,n*2)

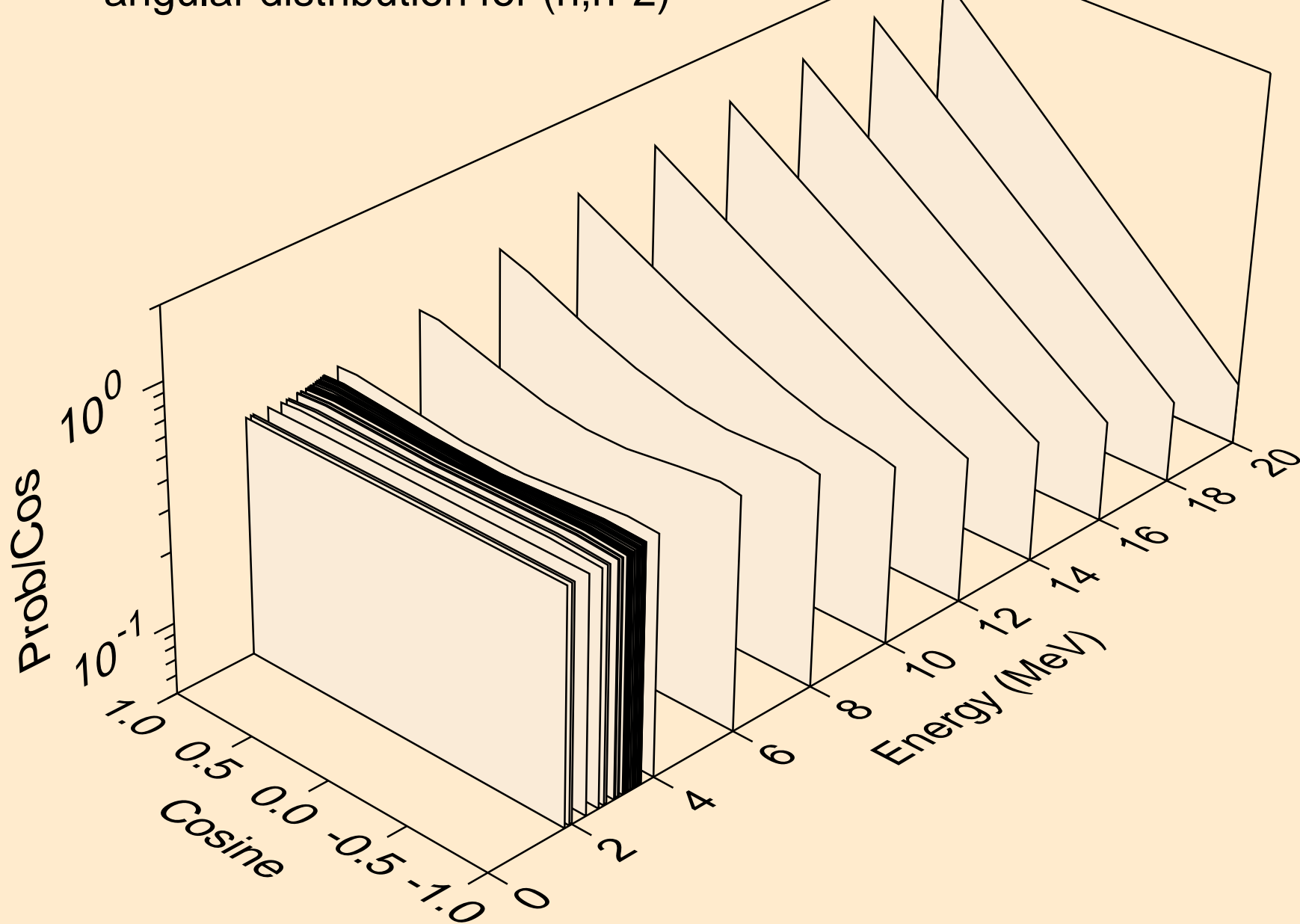

30-ZN-64 FOR FENDL-3.1 FROM FENDL-3.1 WITH NJOY2012.50+
angular distribution for (n,n*3)

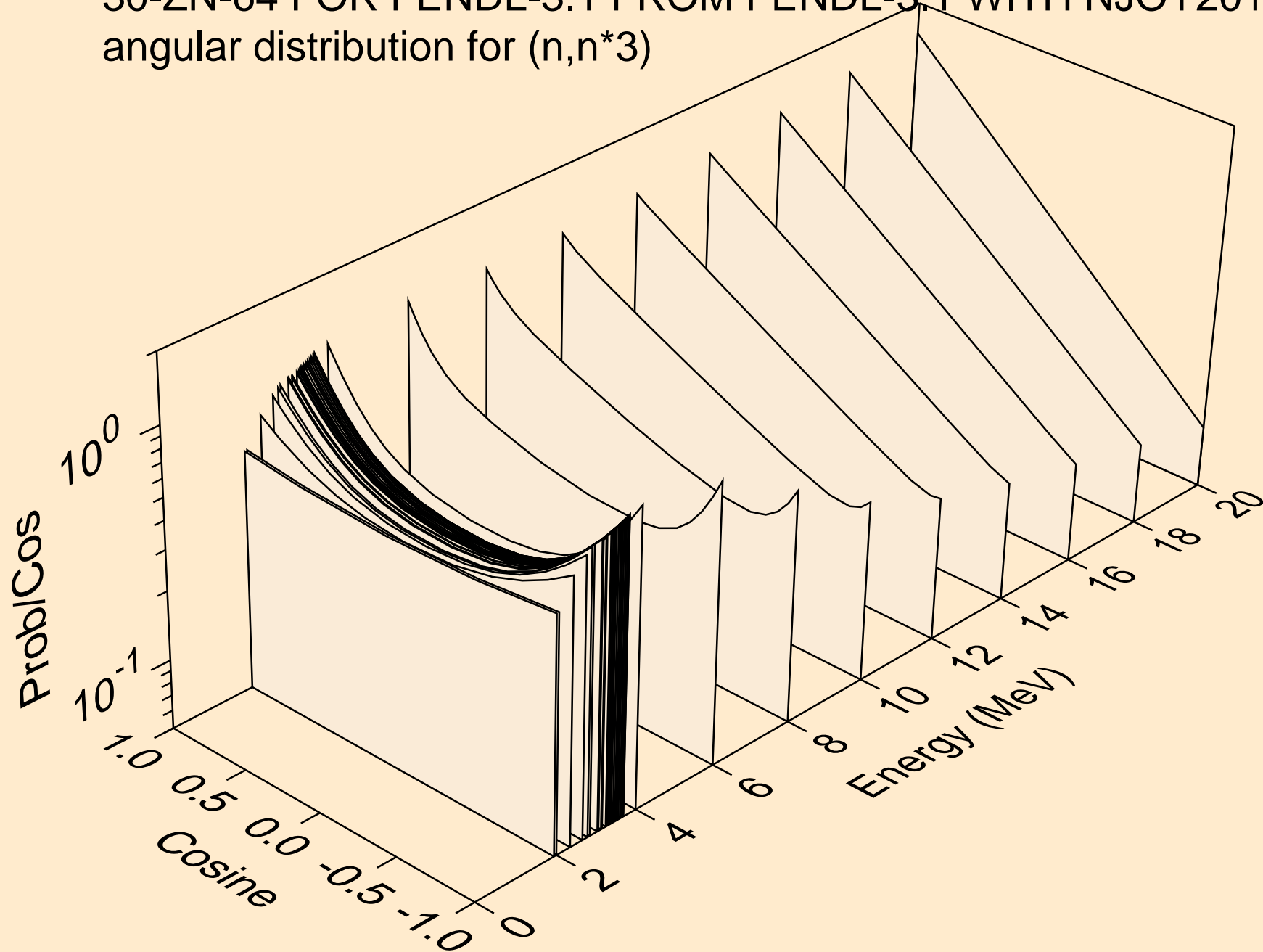

30-ZN-64 FOR FENDL-3.1 FROM FENDL-3.1 WITH NJOY2012.50+
angular distribution for (n,n*4)

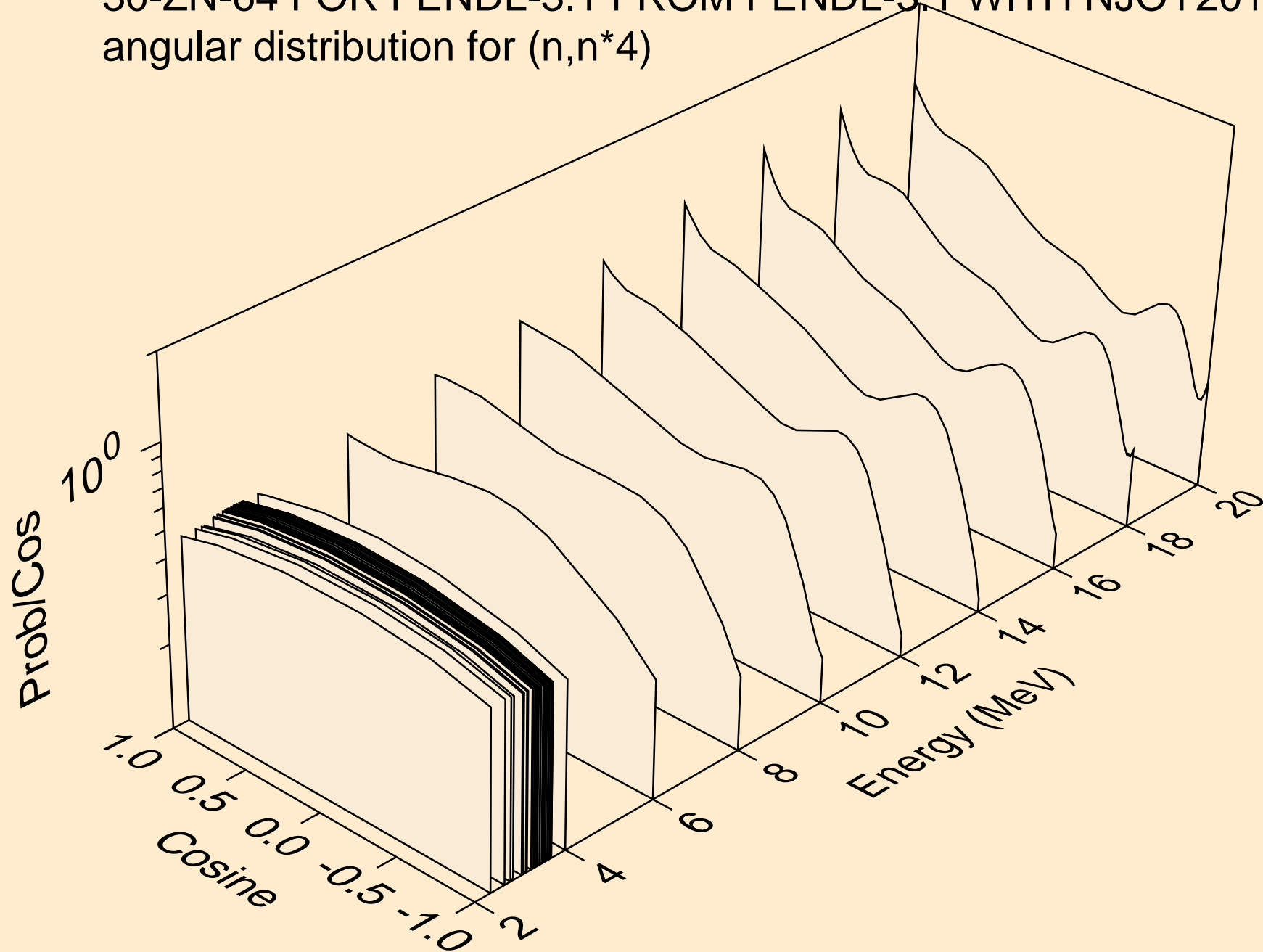

30-ZN-64 FOR FENDL-3.1 FROM FENDL-3.1 WITH NJOY2012.50+
angular distribution for (n,n*5)

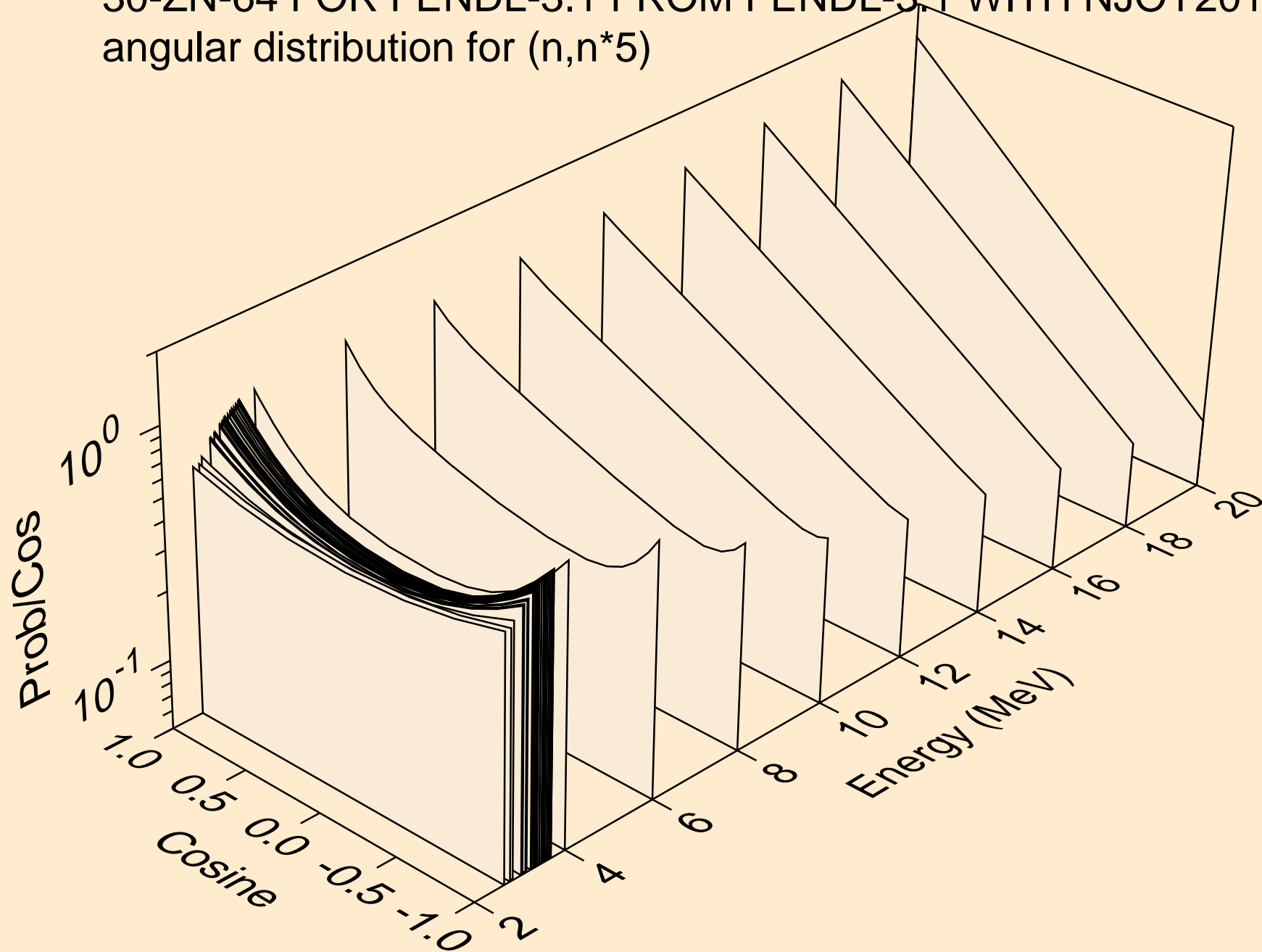

30-ZN-64 FOR FENDL-3.1 FROM FENDL-3.1 WITH NJOY2012.50+
angular distribution for (n,n*6)

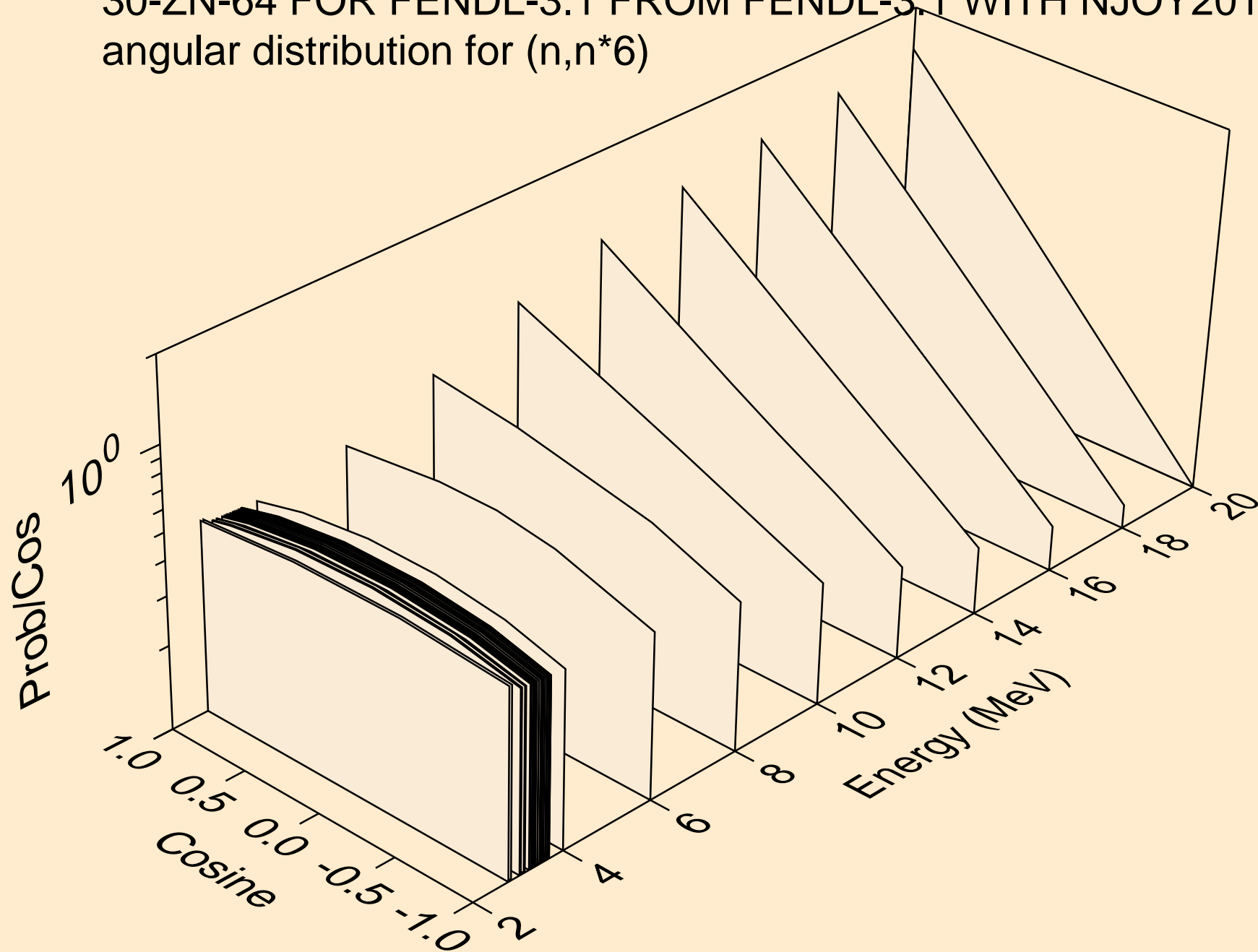

30-ZN-64 FOR FENDL-3.1 FROM FENDL-3.1 WITH NJOY2012.50+
angular distribution for (n,n*7)

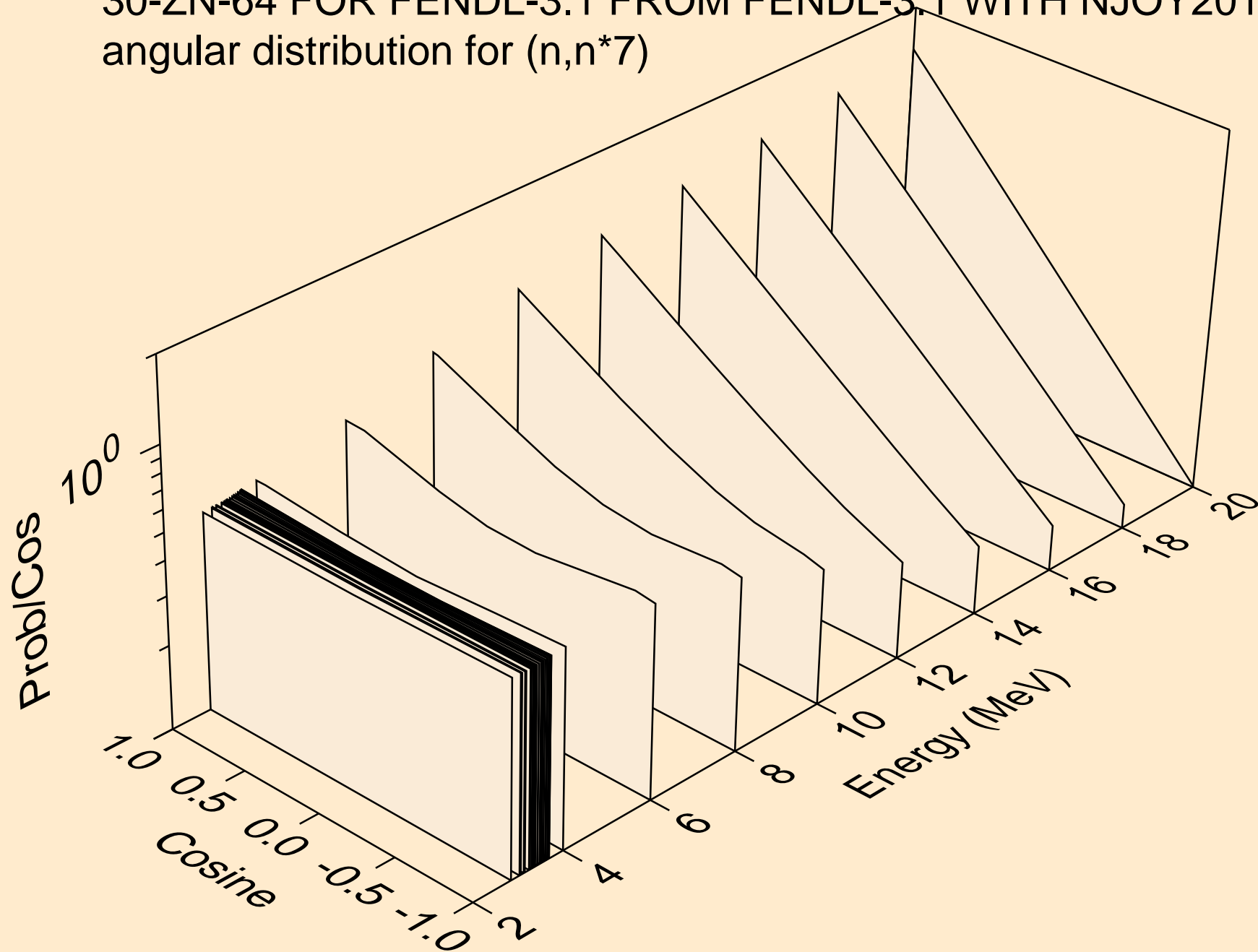

30-ZN-64 FOR FENDL-3.1 FROM FENDL-3.1 WITH NJOY2012.50+
angular distribution for (n,n*8)

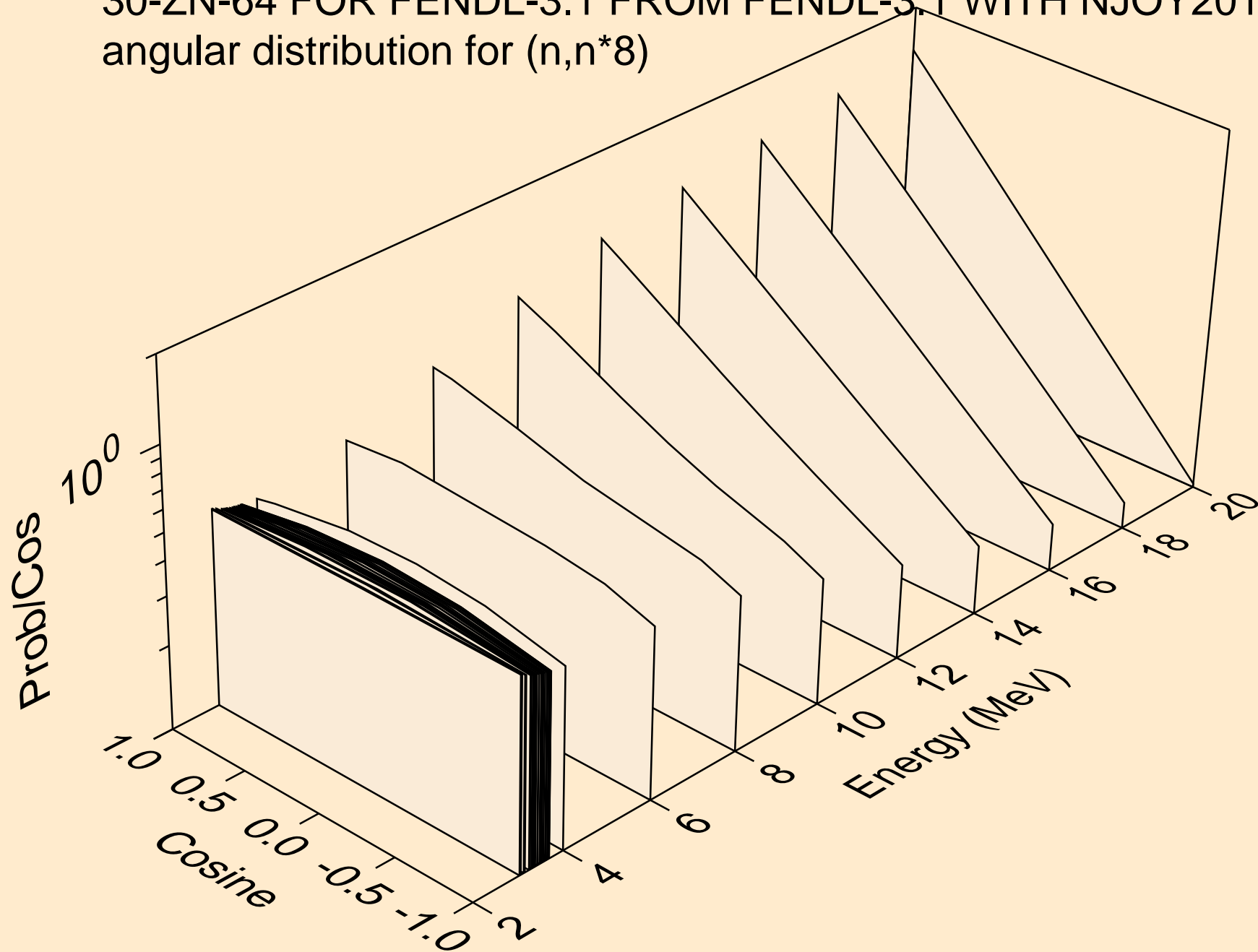

30-ZN-64 FOR FENDL-3.1 FROM FENDL-3.1 WITH NJOY2012.50+
angular distribution for (n,n*9)

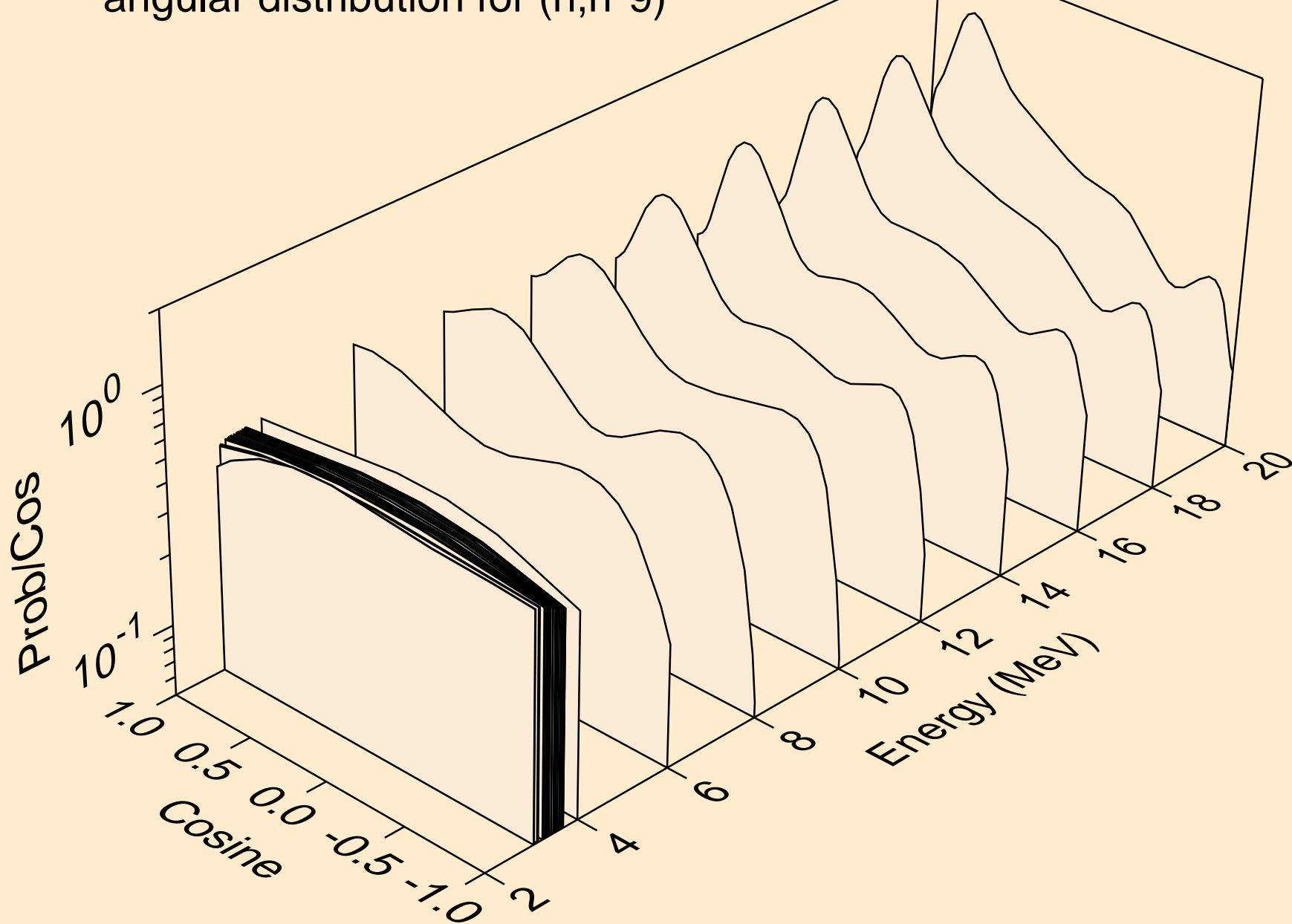

30-ZN-64 FOR FENDL-3.1 FROM FENDL-3.1 WITH NJOY2012.50+
angular distribution for (n,n*10)

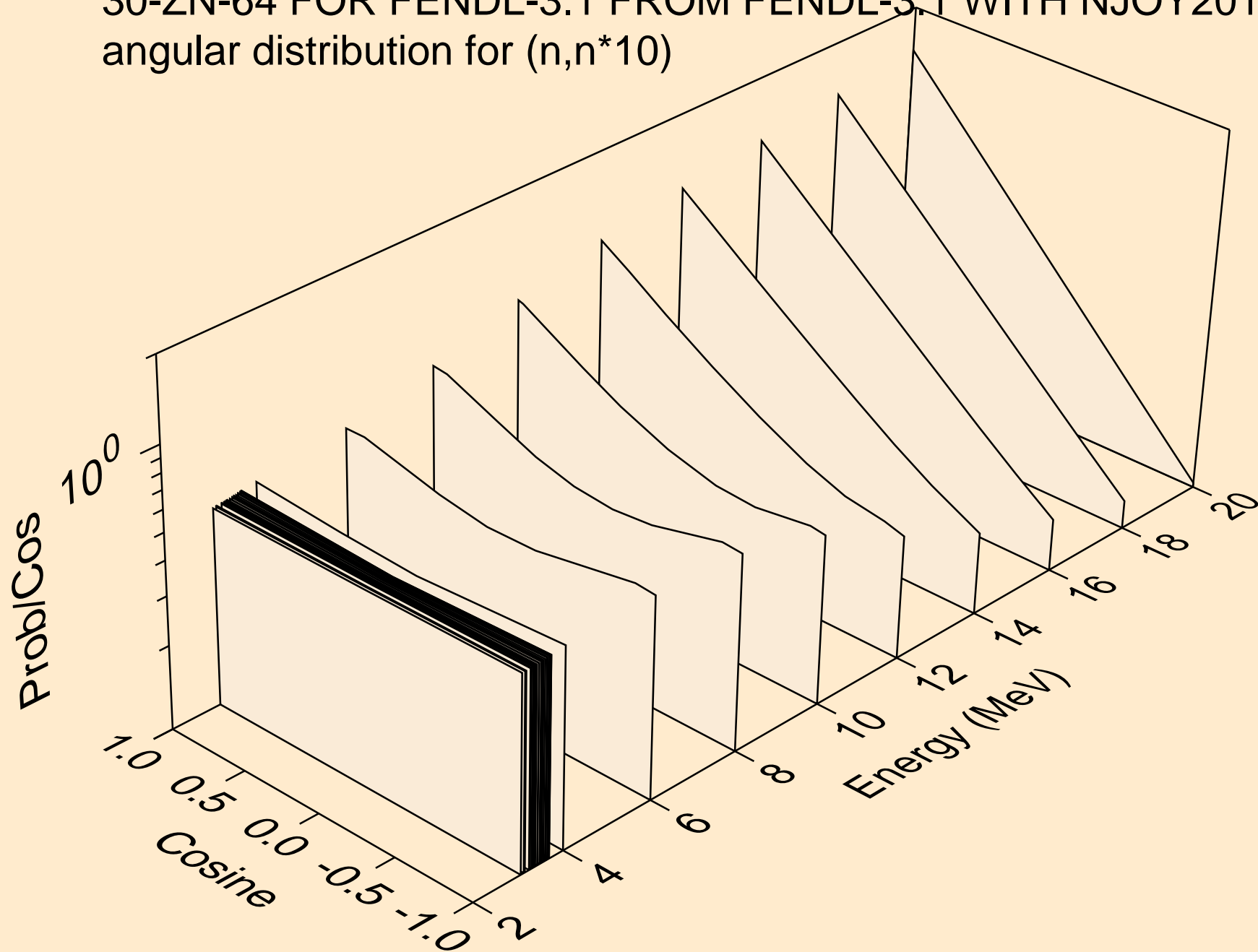

30-ZN-64 FOR FENDL-3.1 FROM FENDL-3.1 WITH NJOY2012.50+
angular distribution for (n,n*11)

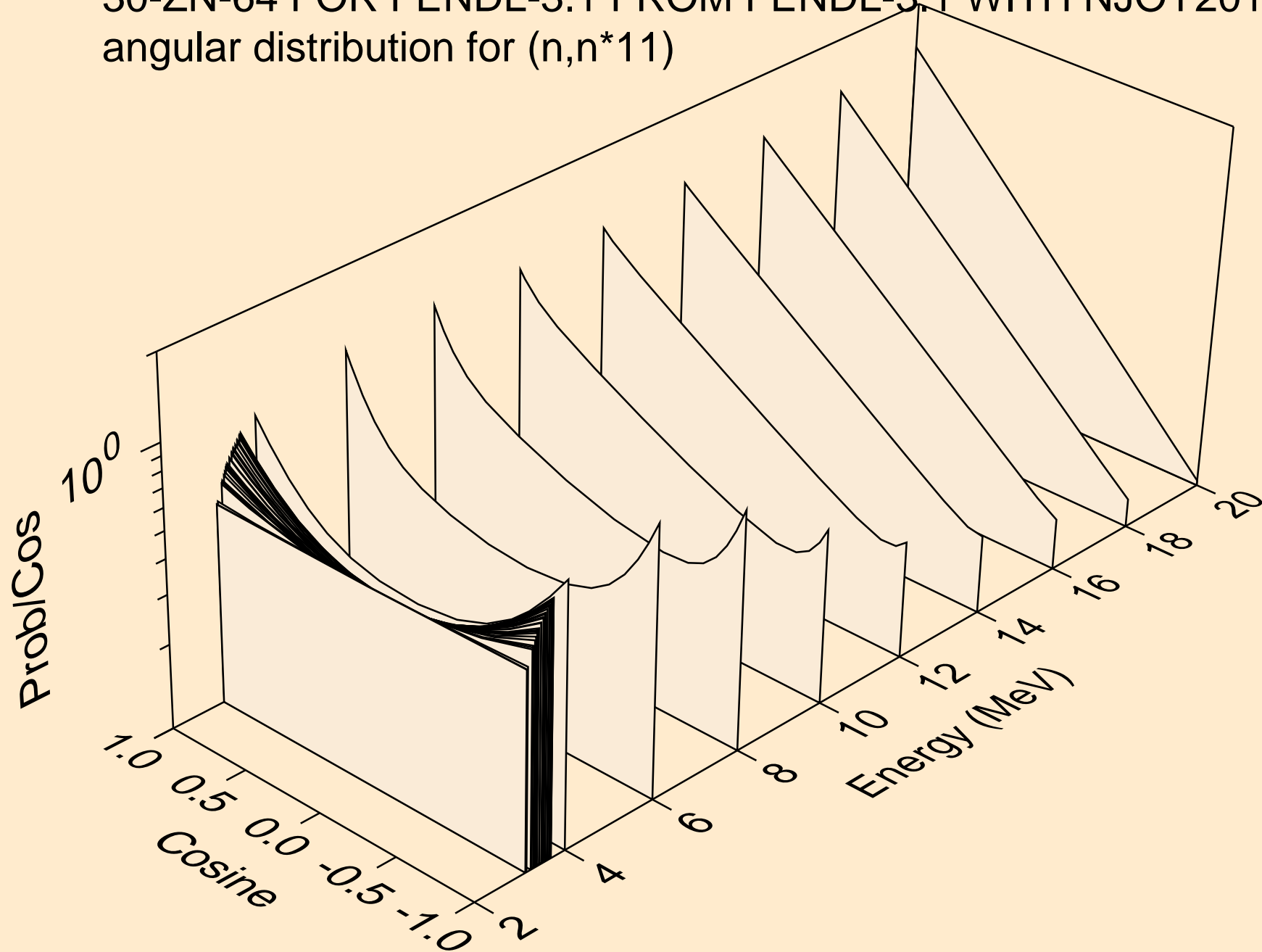

30-ZN-64 FOR FENDL-3.1 FROM FENDL-3.1 WITH NJOY2012.50+
angular distribution for (n,n*12)

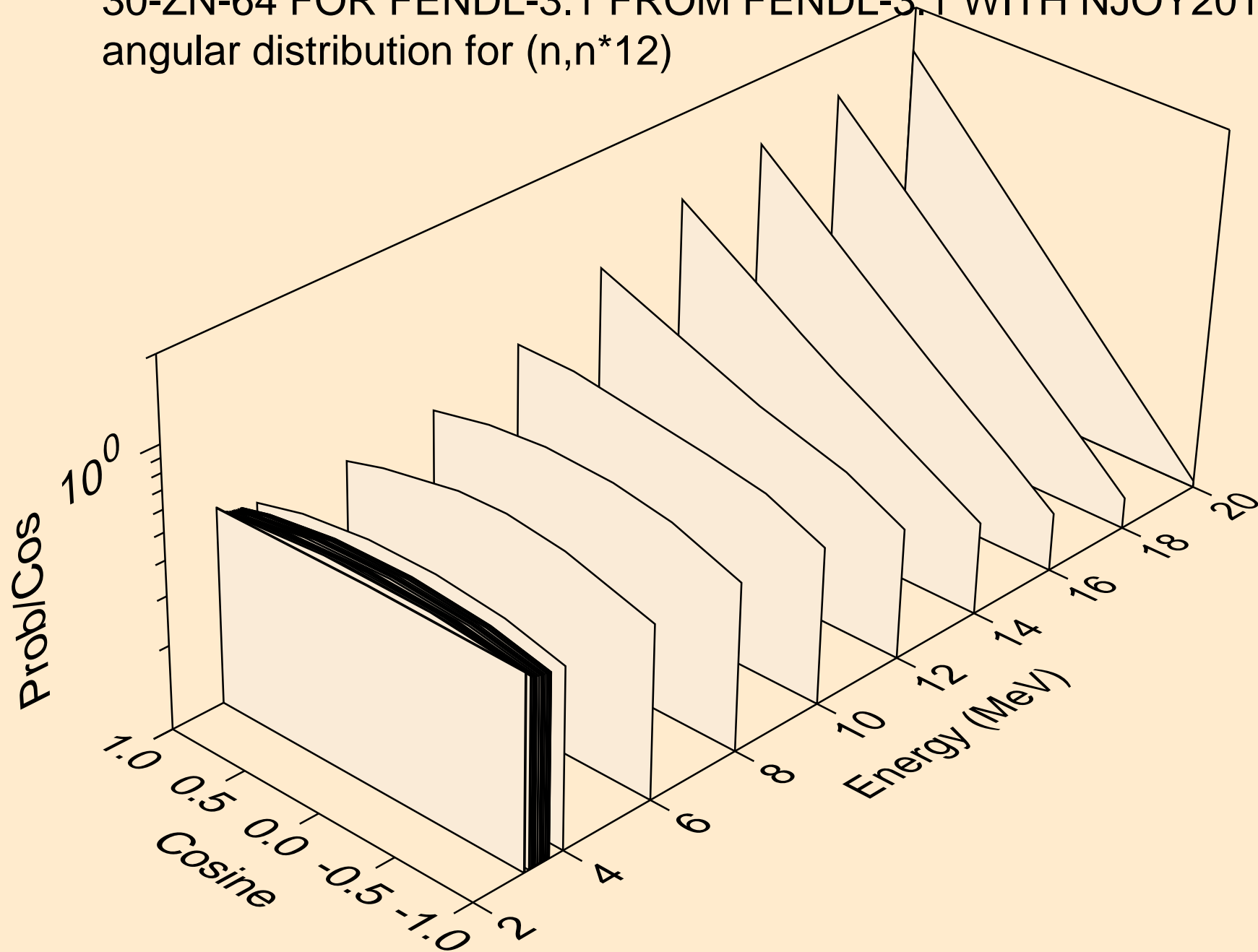

30-ZN-64 FOR FENDL-3.1 FROM FENDL-3.1 WITH NJOY2012.50+
angular distribution for (n,n*13)

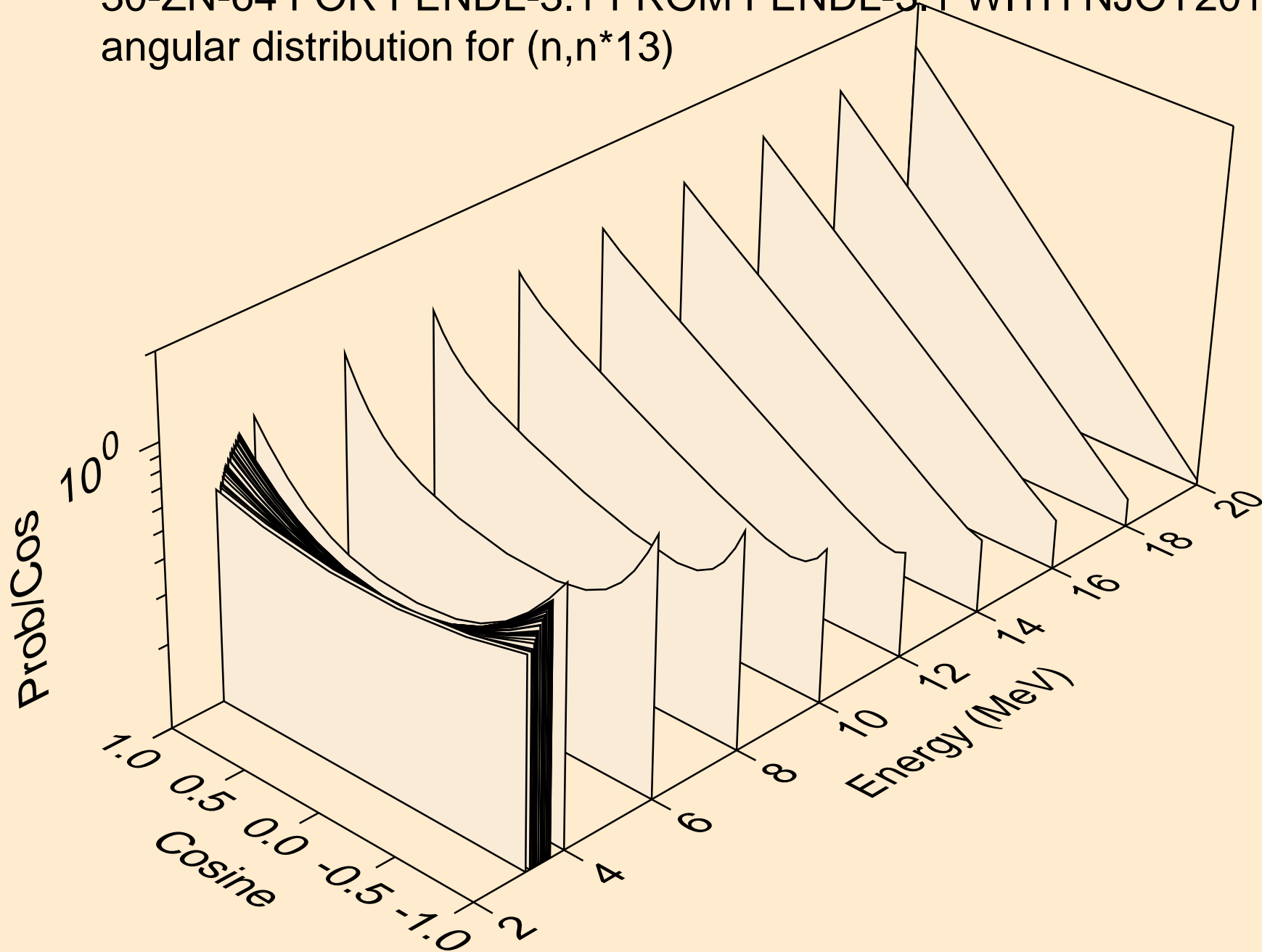

30-ZN-64 FOR FENDL-3.1 FROM FENDL-3.1 WITH NJOY2012.50+
angular distribution for (n,n*14)

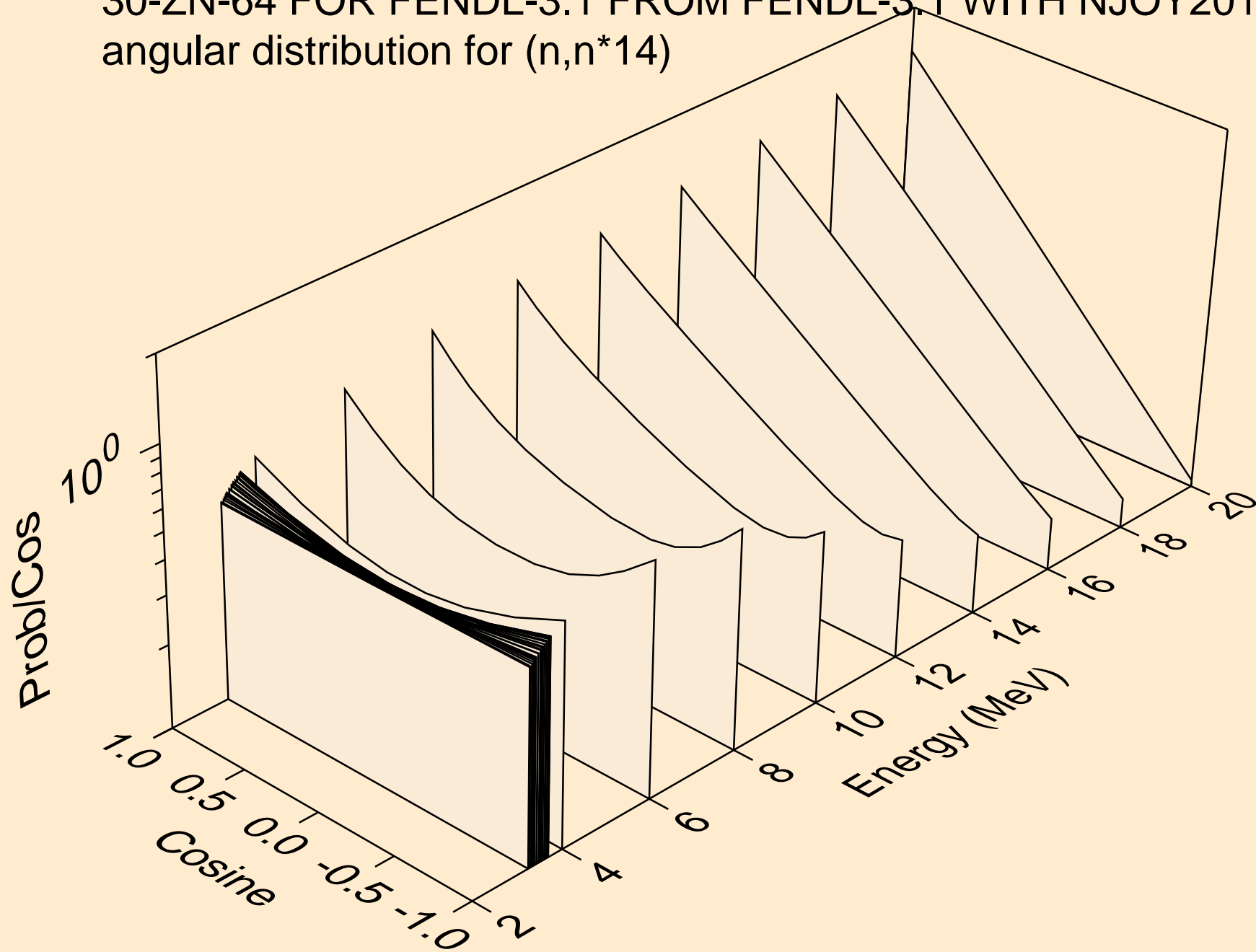

30-ZN-64 FOR FENDL-3.1 FROM FENDL-3.1 WITH NJOY2012.50+
angular distribution for (n,n*15)

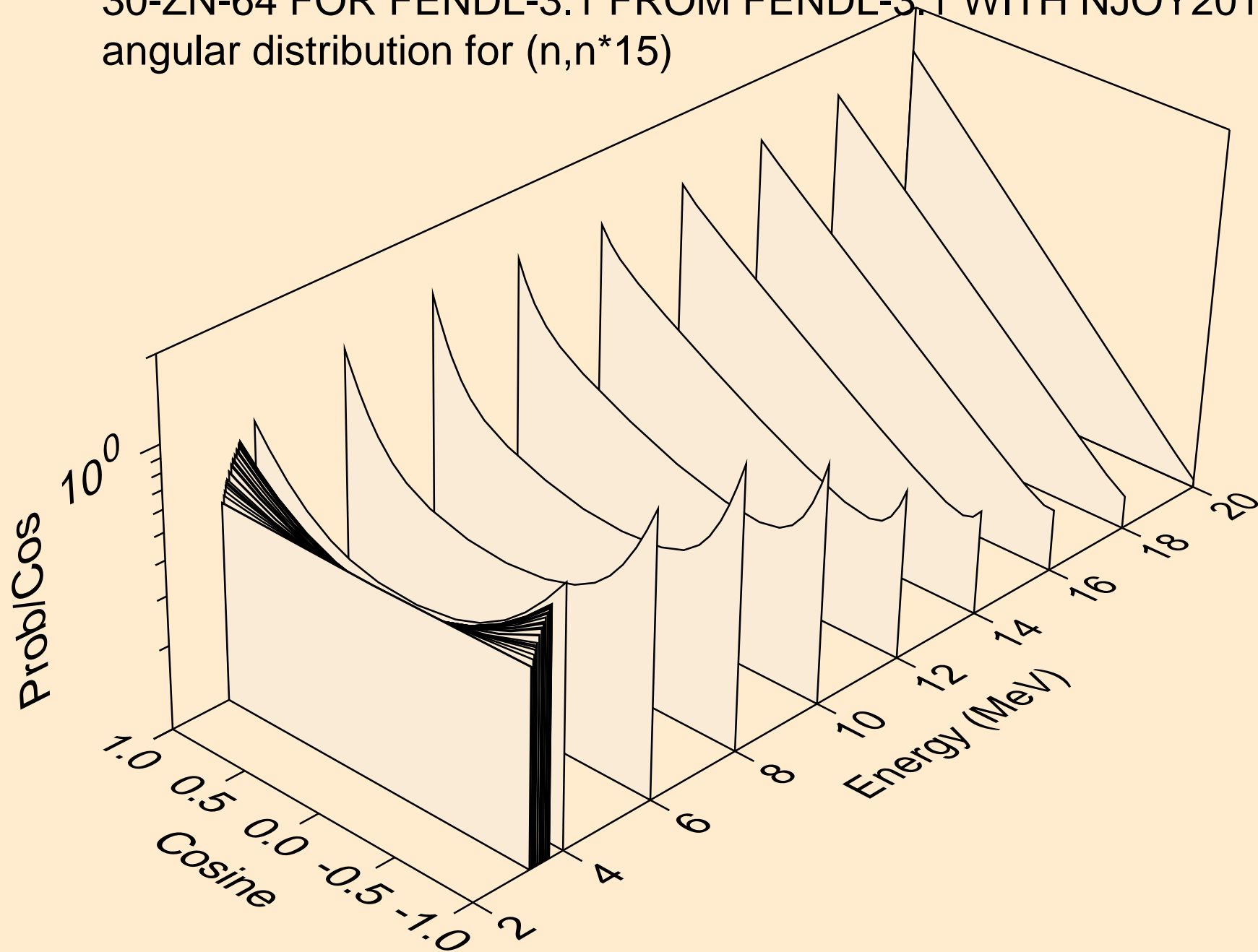

30-ZN-64 FOR FENDL-3.1 FROM FENDL-3.1 WITH NJOY2012.50+
angular distribution for (n,n*16)

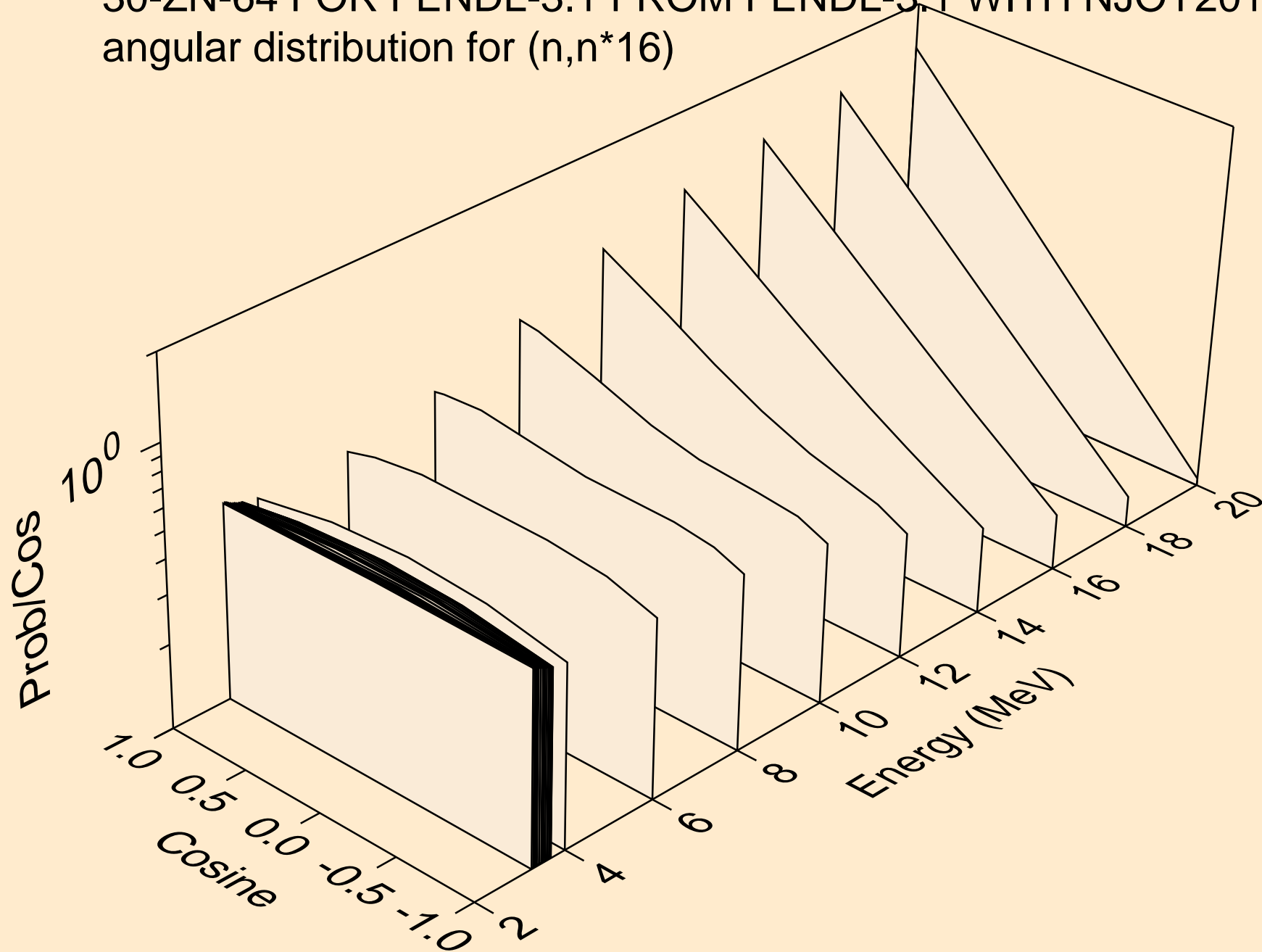

30-ZN-64 FOR FENDL-3.1 FROM FENDL-3.1 WITH NJOY2012.50+
angular distribution for (n,n*17)

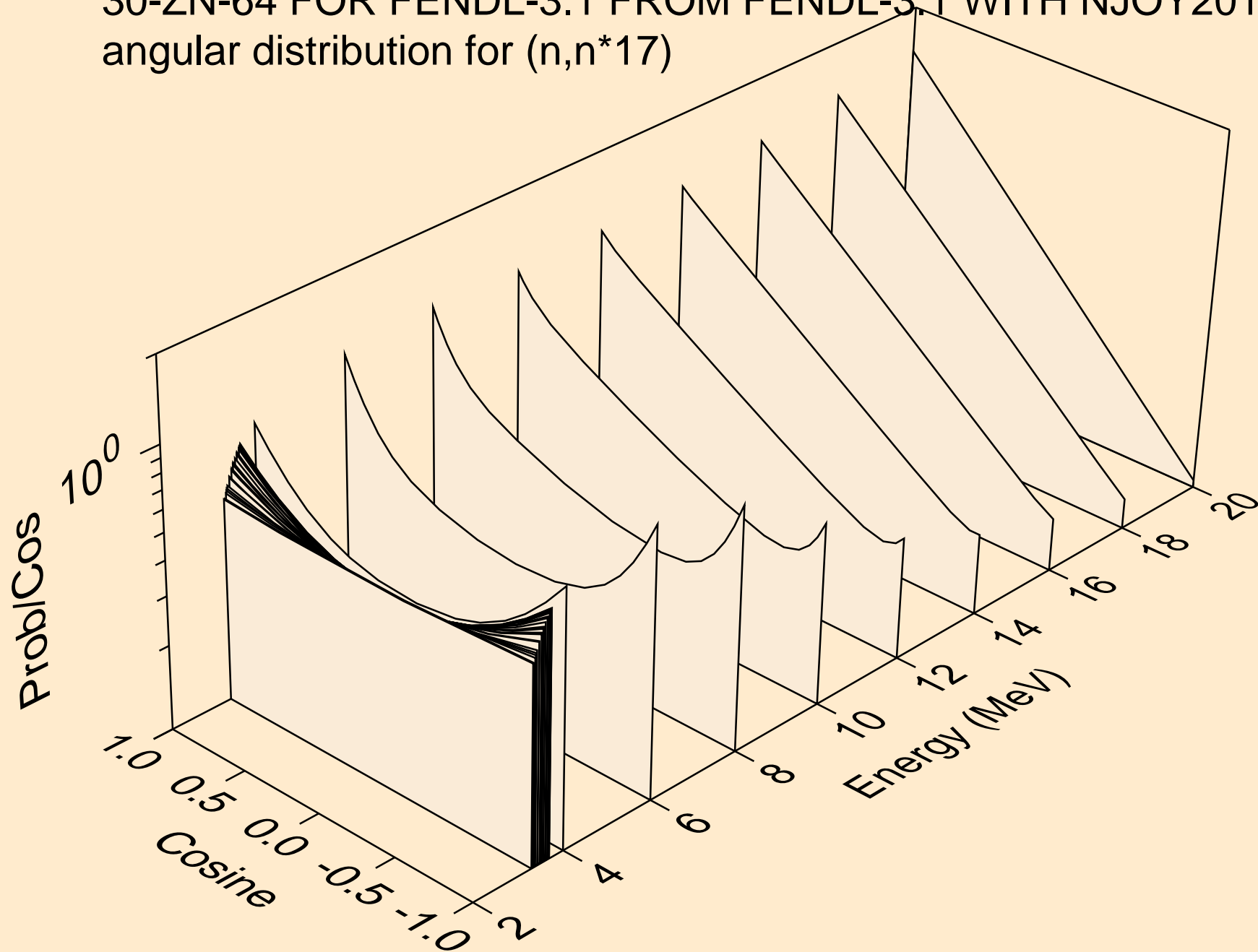

30-ZN-64 FOR FENDL-3.1 FROM FENDL-3.1 WITH NJOY2012.50+
angular distribution for (n,n*18)

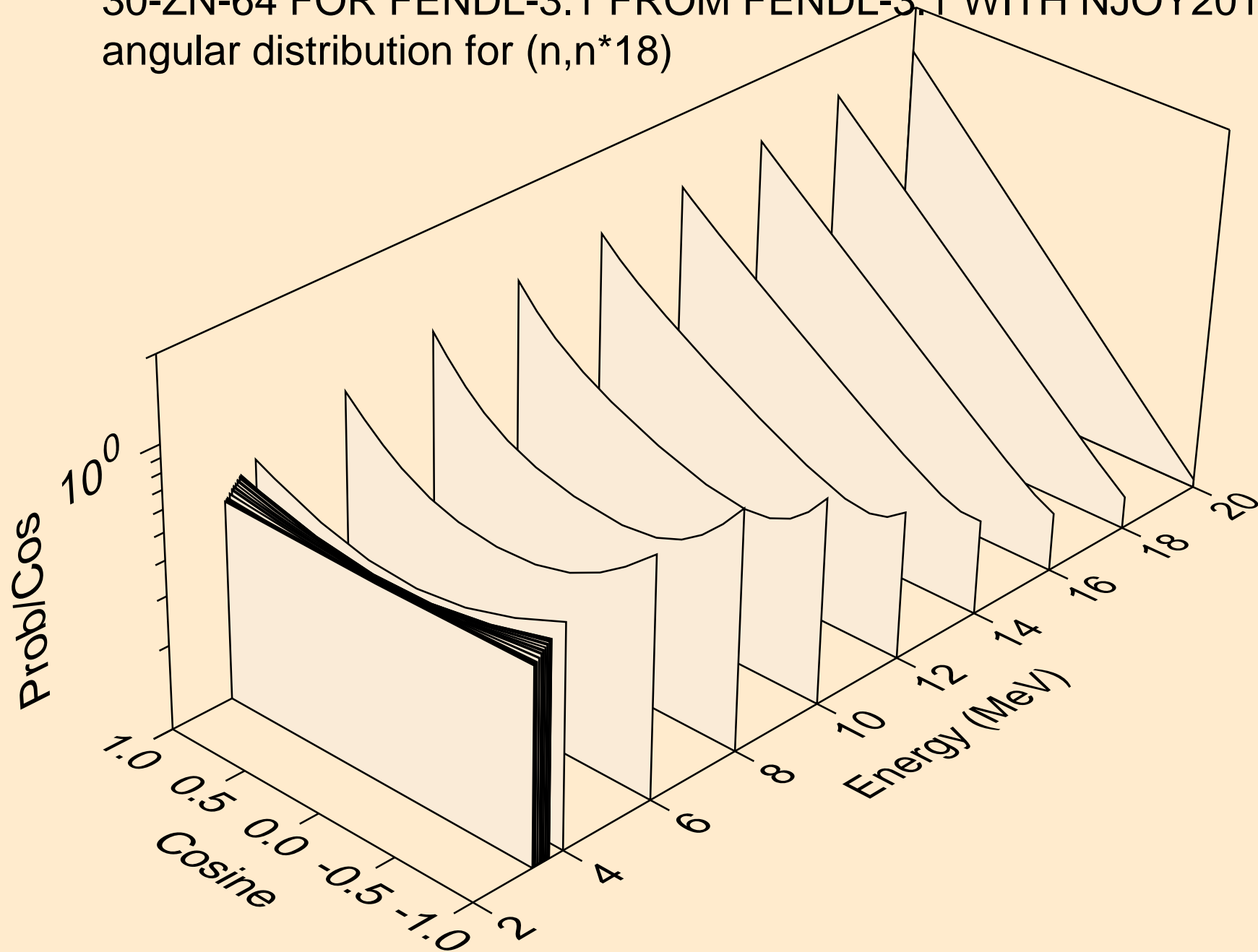

30-ZN-64 FOR FENDL-3.1 FROM FENDL-3.1 WITH NJOY2012.50+
angular distribution for (n,n*19)

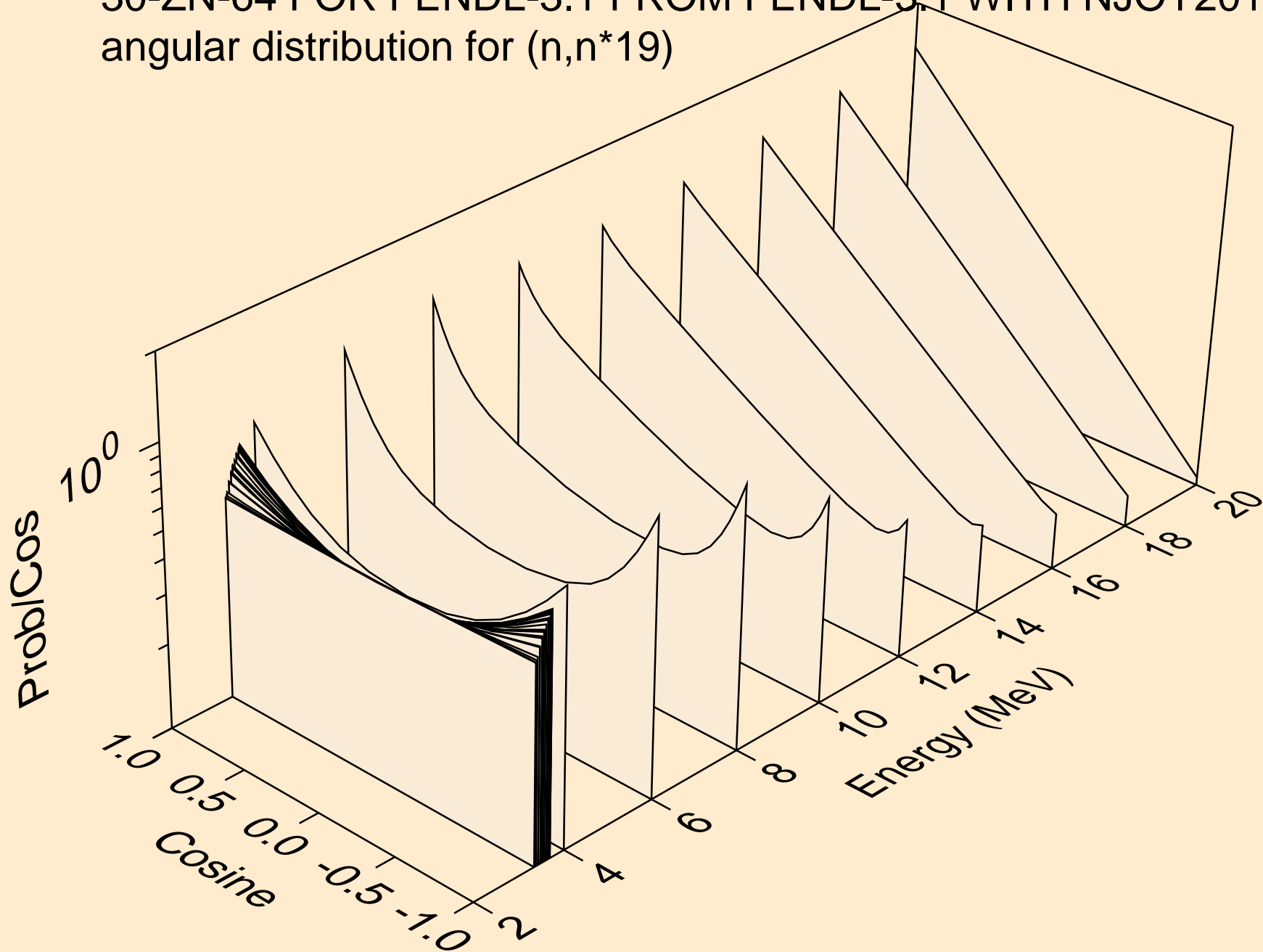

30-ZN-64 FOR FENDL-3.1 FROM FENDL-3.1 WITH NJOY2012.50+
angular distribution for (n,n*20)

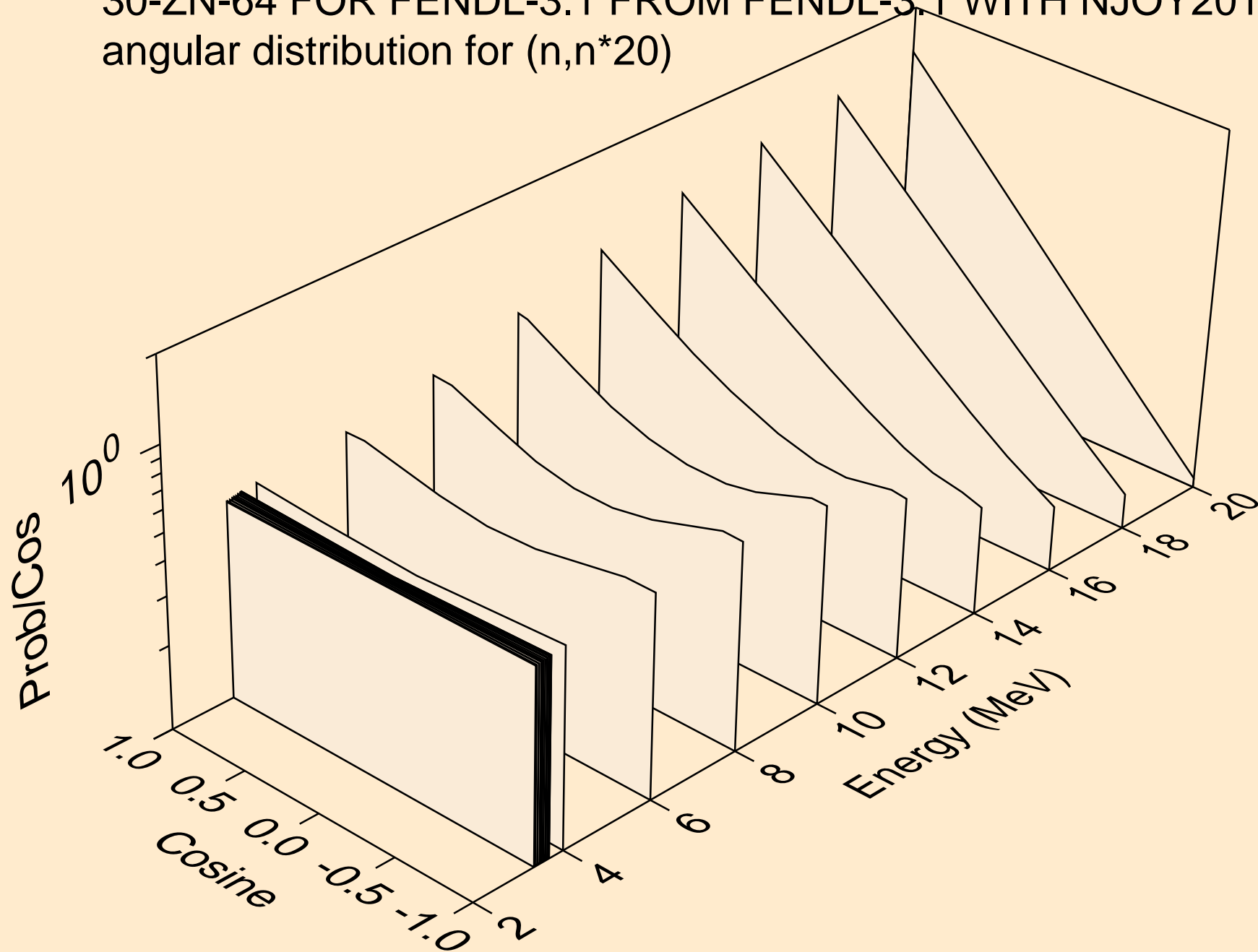

30-ZN-64 FOR FENDL-3.1 FROM FENDL-3.1 WITH NJOY2012.50+
angular distribution for (n,n*21)

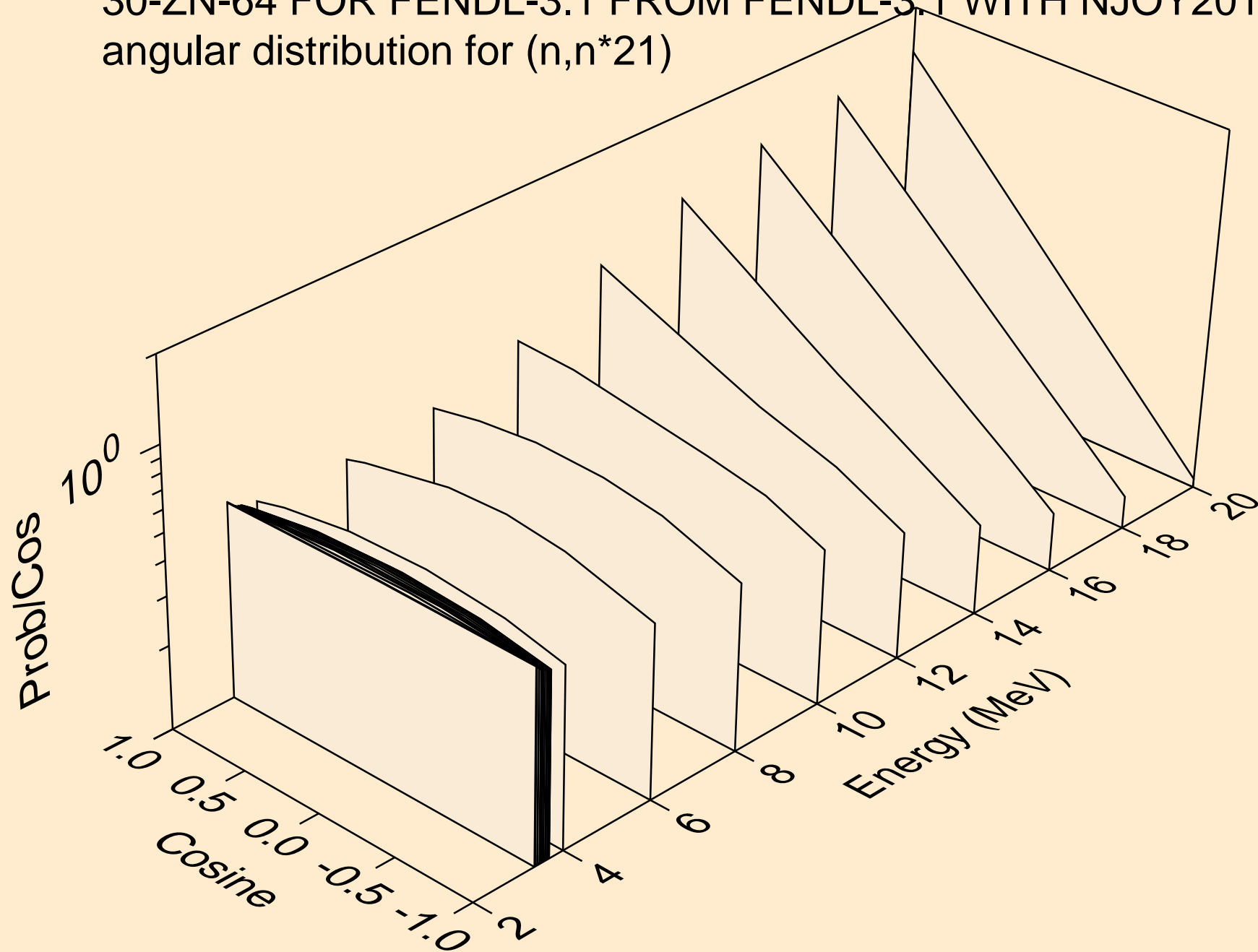

30-ZN-64 FOR FENDL-3.1 FROM FENDL-3.1 WITH NJOY2012.50+
angular distribution for (n,n*22)

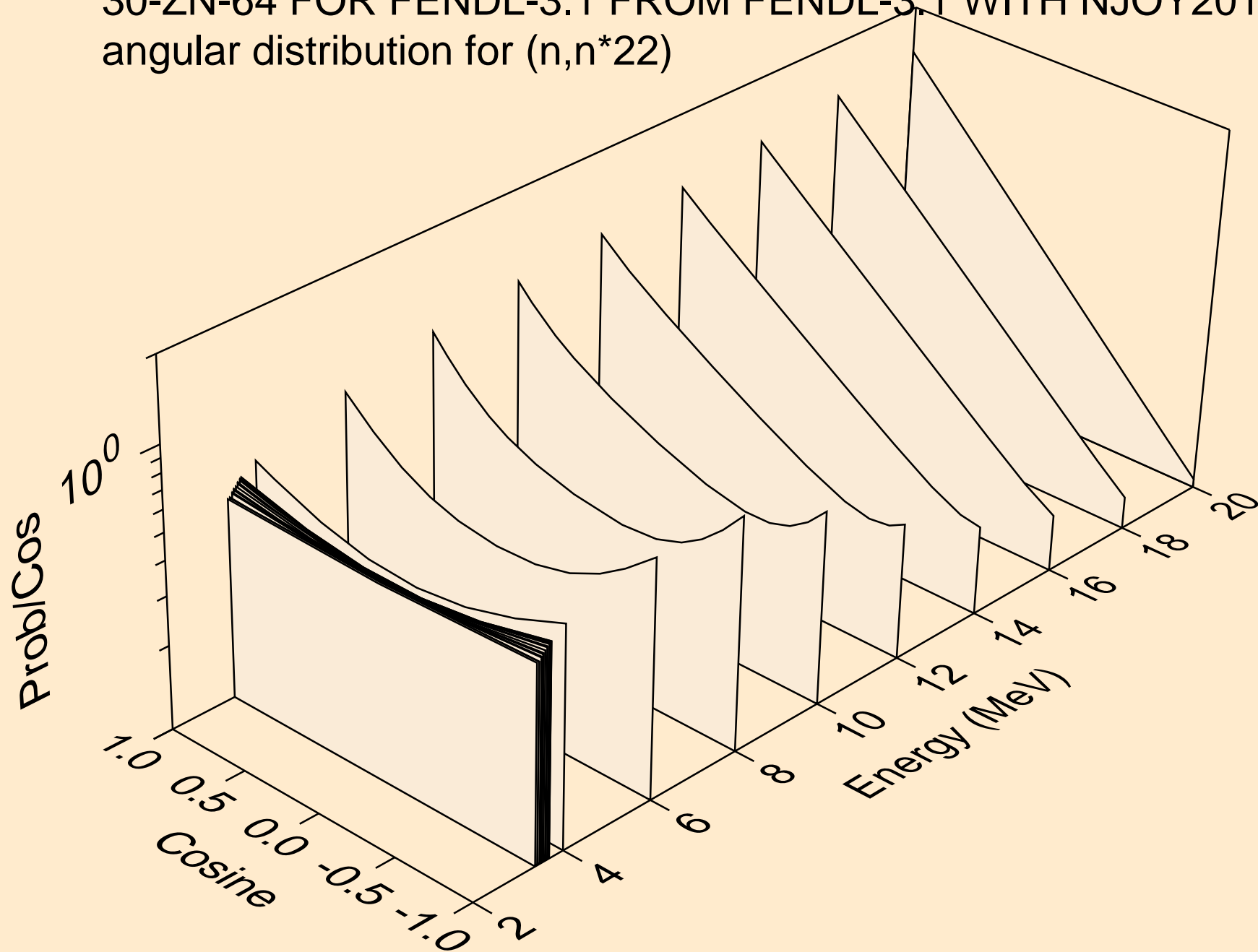

30-ZN-64 FOR FENDL-3.1 FROM FENDL-3.1 WITH NJOY2012.50+
angular distribution for (n,n*23)

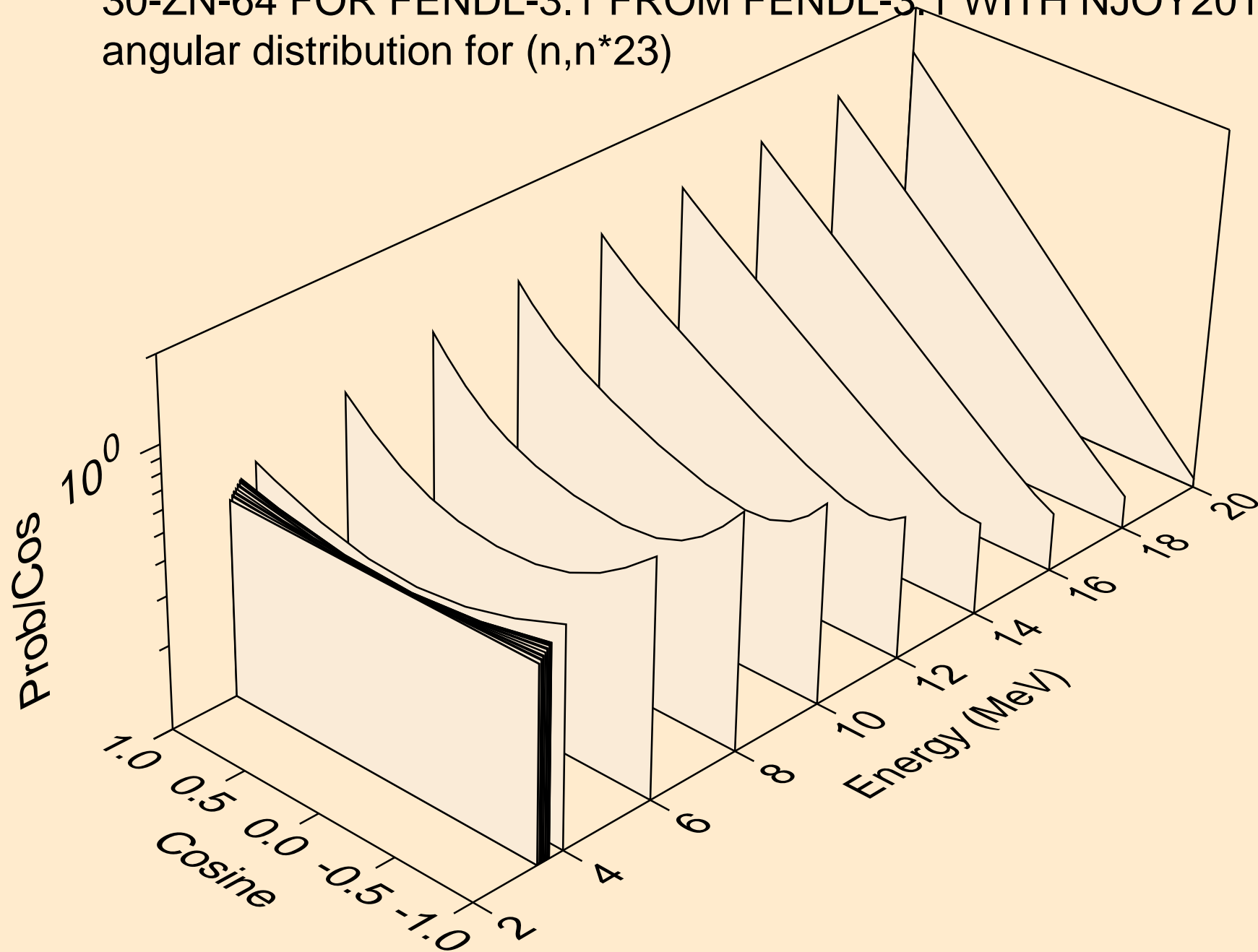

30-ZN-64 FOR FENDL-3.1 FROM FENDL-3.1 WITH NJOY2012.50+
angular distribution for (n,n*24)

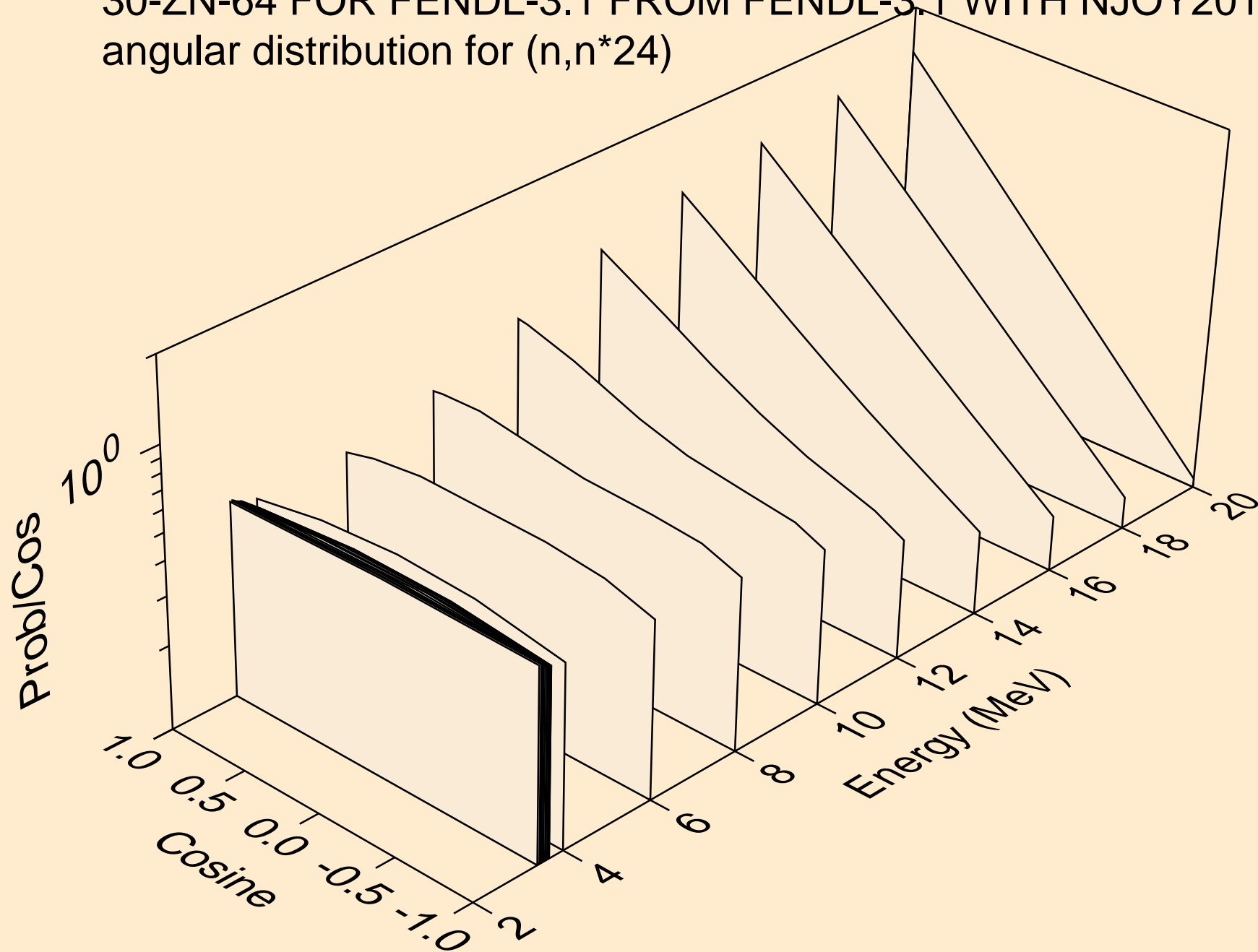

30-ZN-64 FOR FENDL-3.1 FROM FENDL-3.1 WITH NJOY2012.50+
angular distribution for (n,n*25)

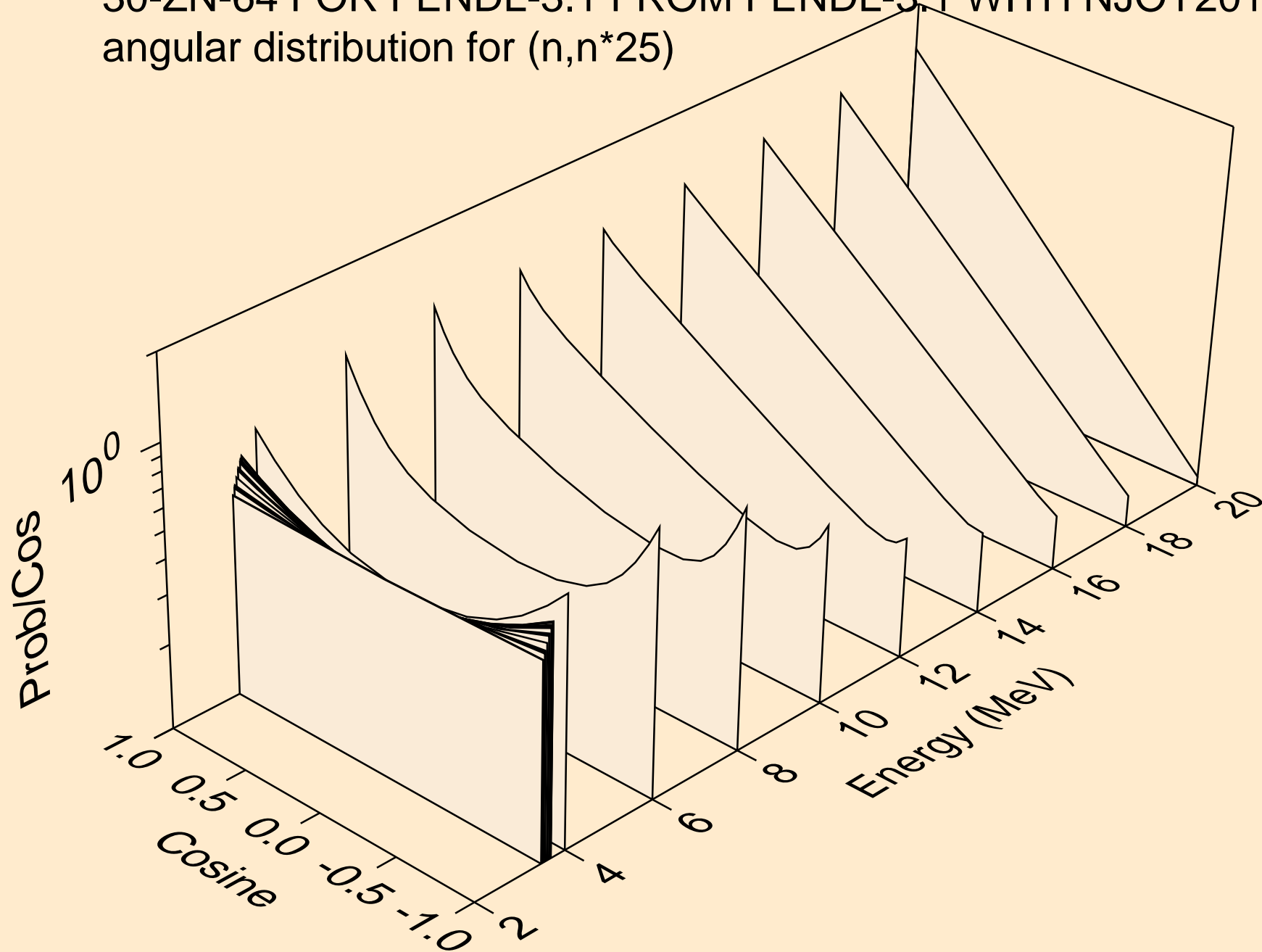

30-ZN-64 FOR FENDL-3.1 FROM FENDL-3.1 WITH NJOY2012.50+
angular distribution for (n,n*26)

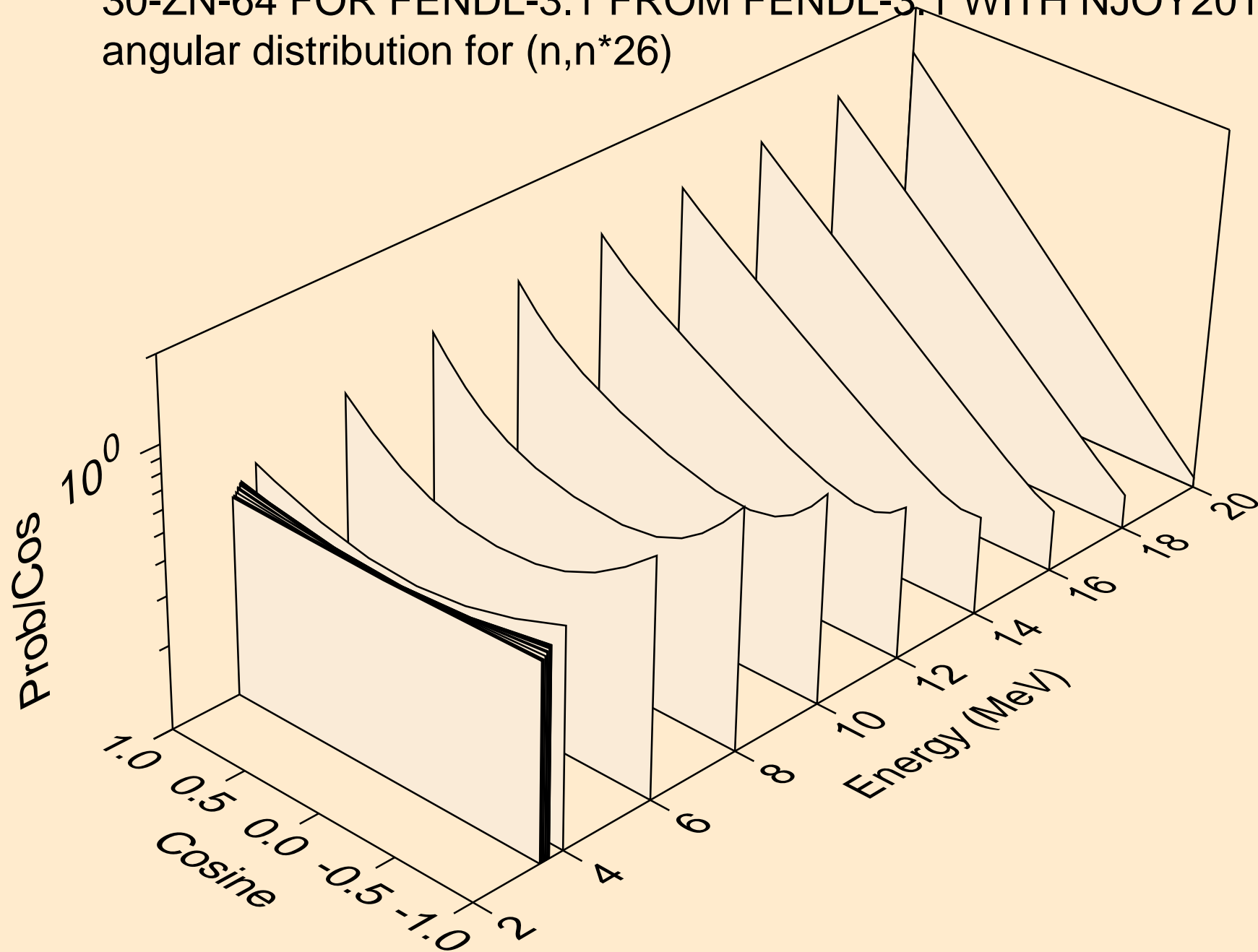

30-ZN-64 FOR FENDL-3.1 FROM FENDL-3.1 WITH NJOY2012.50+
angular distribution for (n,n*27)

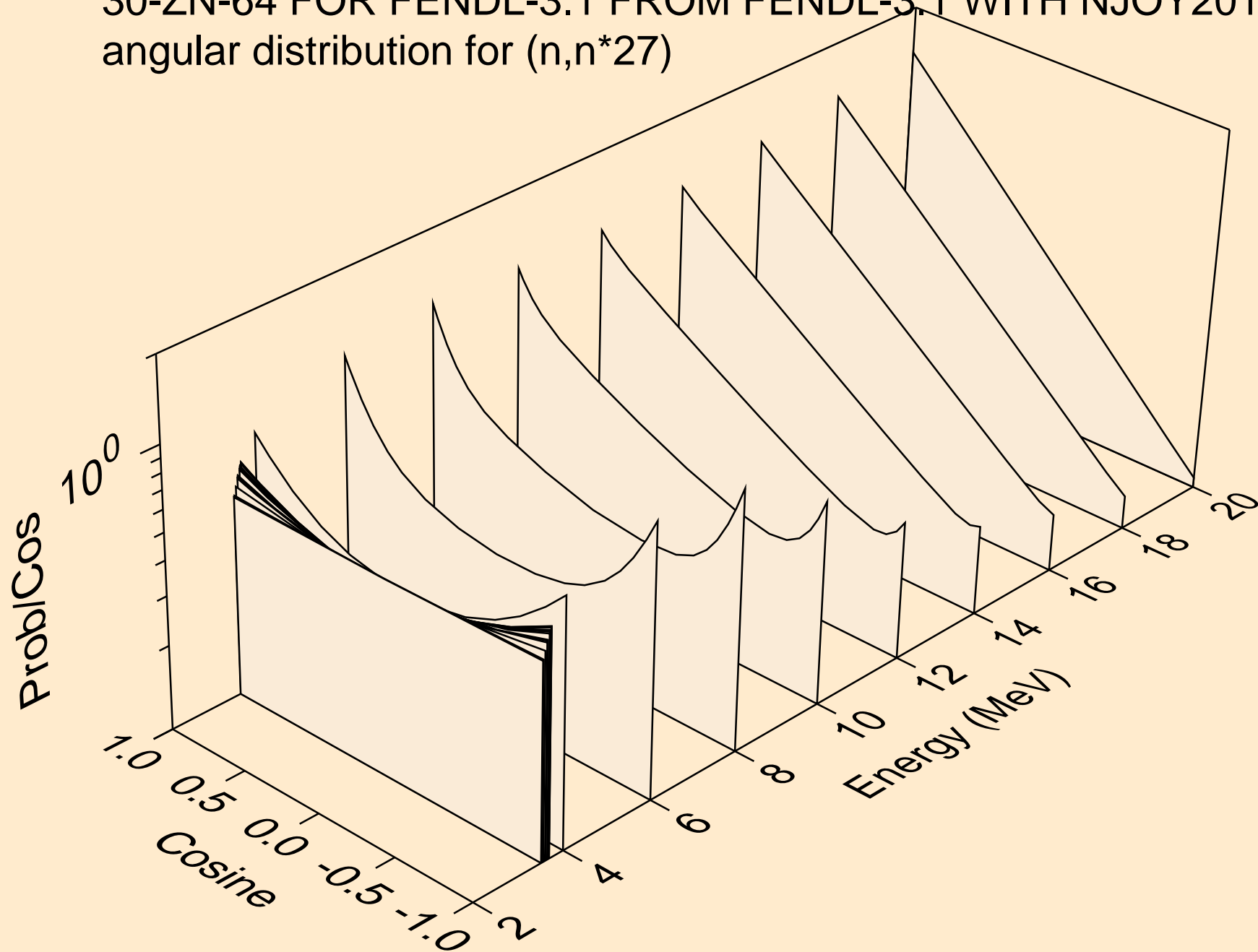

30-ZN-64 FOR FENDL-3.1 FROM FENDL-3.1 WITH NJOY2012.50+
angular distribution for (n,n*28)

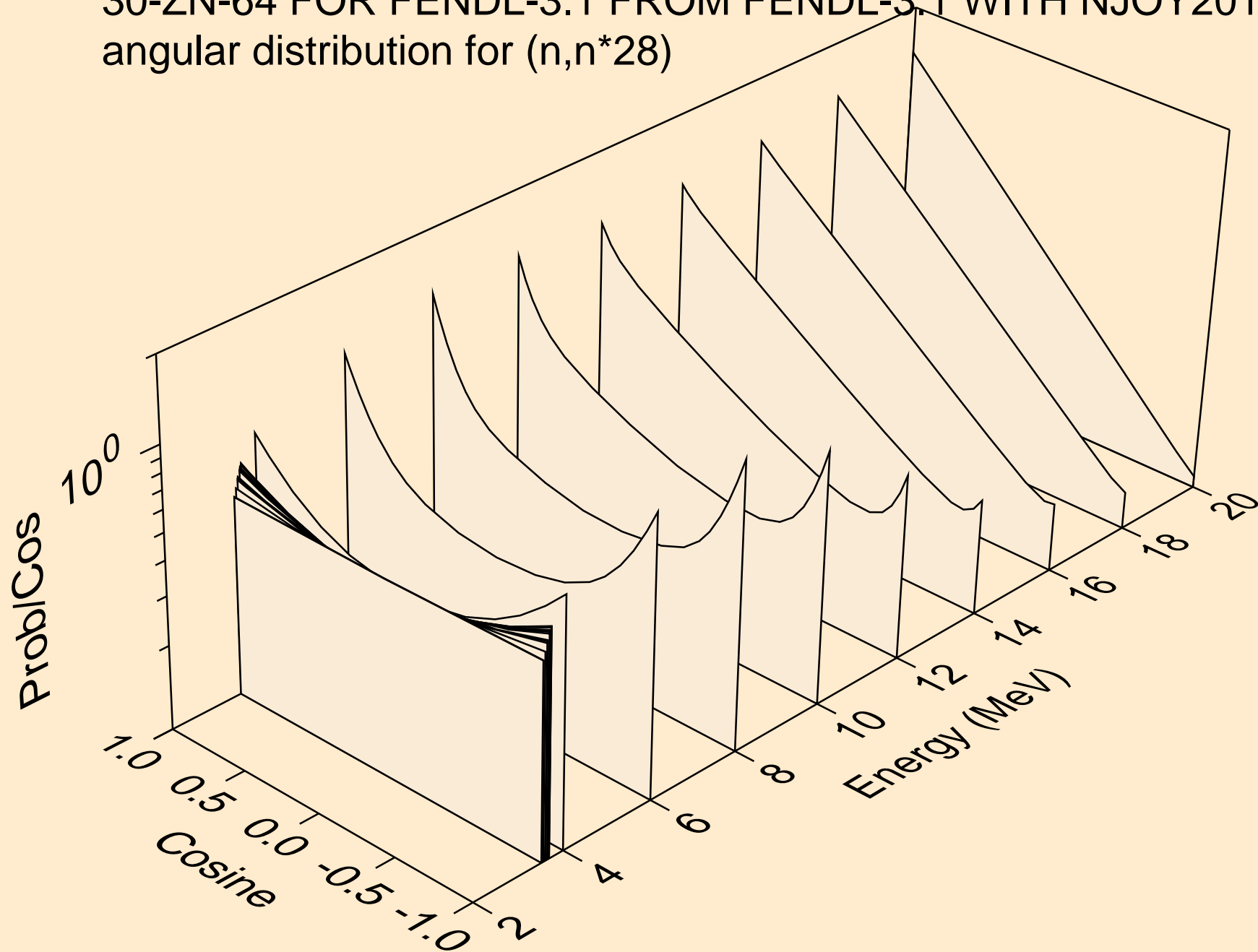

30-ZN-64 FOR FENDL-3.1 FROM FENDL-3.1 WITH NJOY2012.50+
angular distribution for (n,n*29)

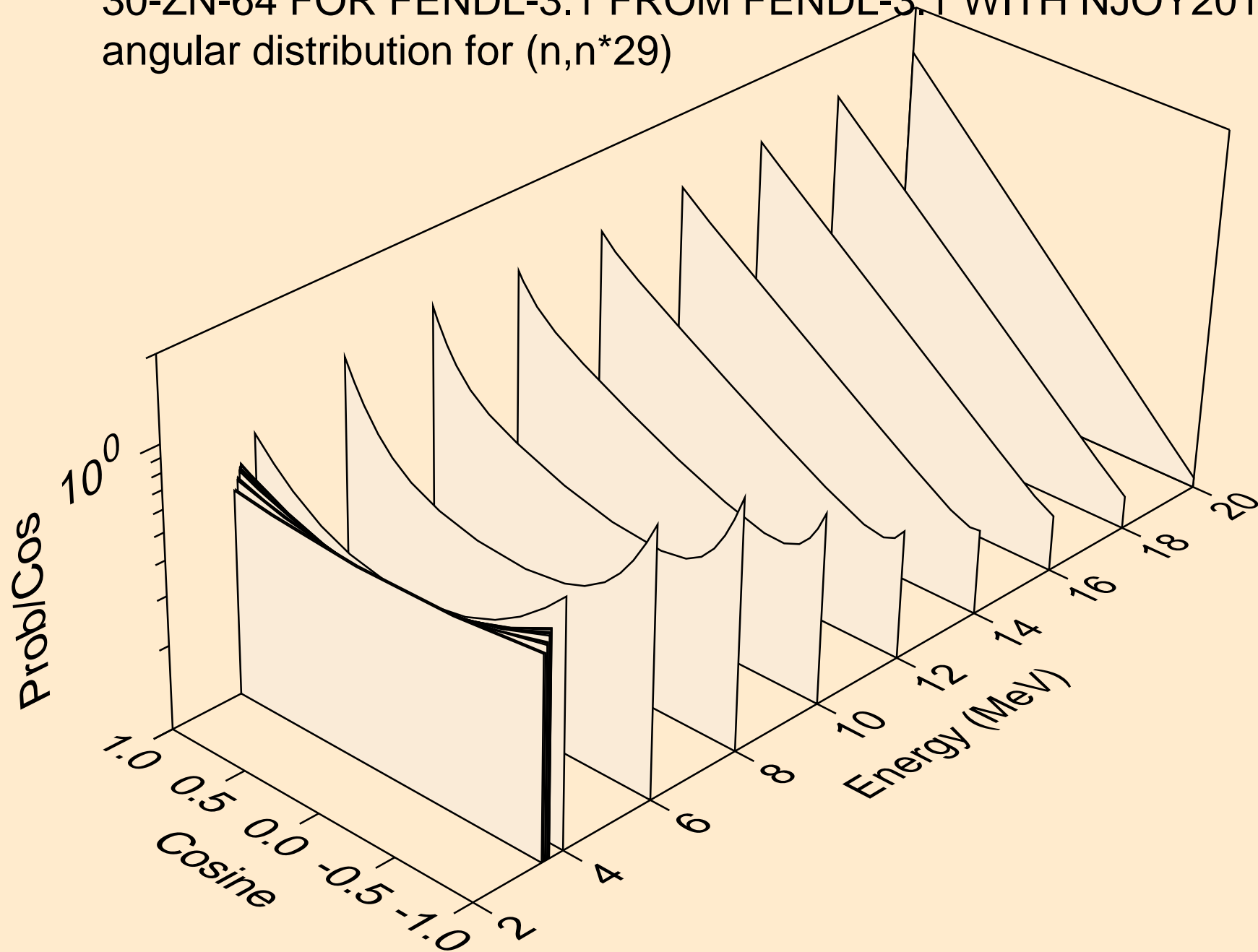

30-ZN-64 FOR FENDL-3.1 FROM FENDL-3.1 WITH NJOY2012.50+
angular distribution for (n,n*30)

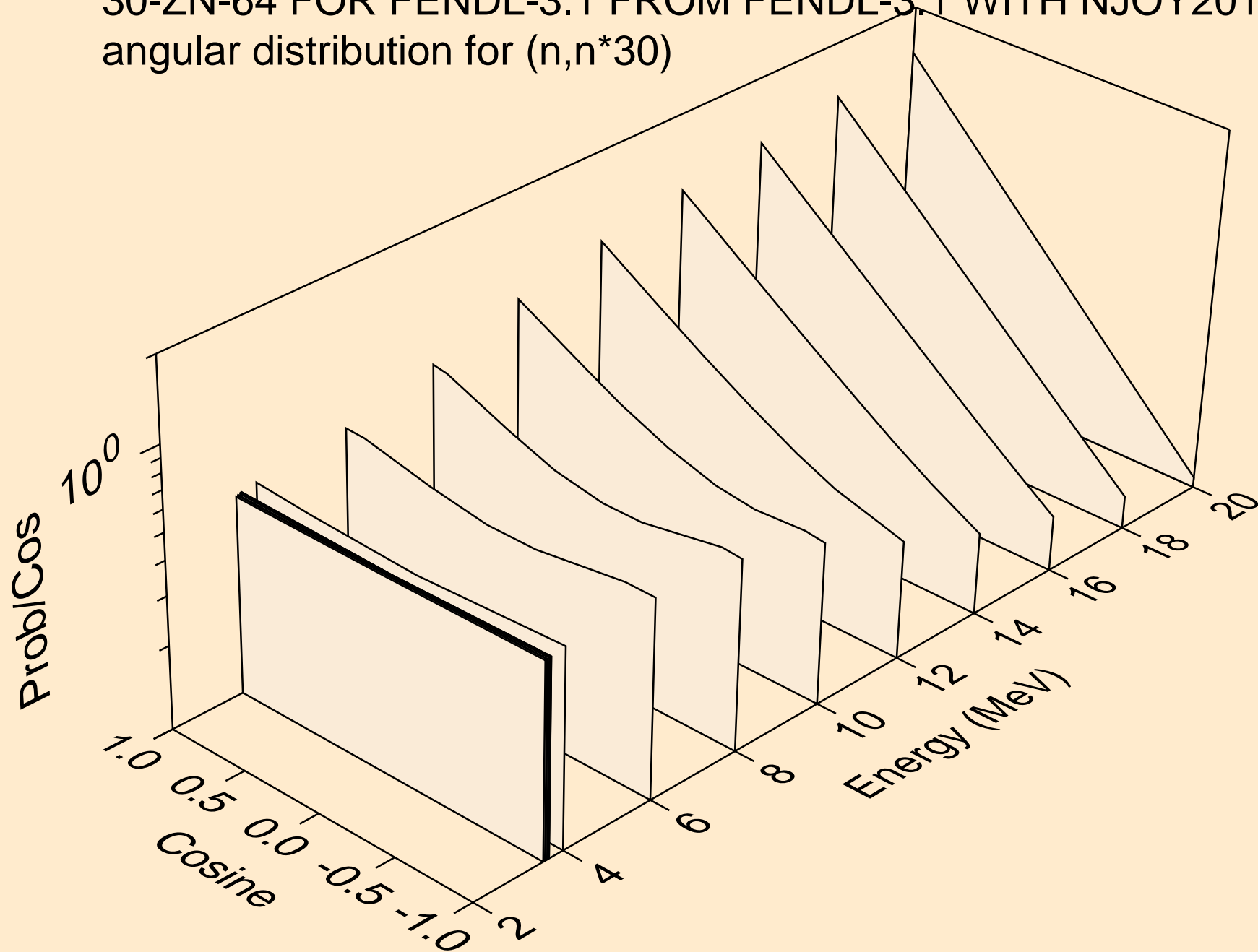

30-ZN-64 FOR FENDL-3.1 FROM FENDL-3.1 WITH NJOY2012.50+
angular distribution for (n,n*31)

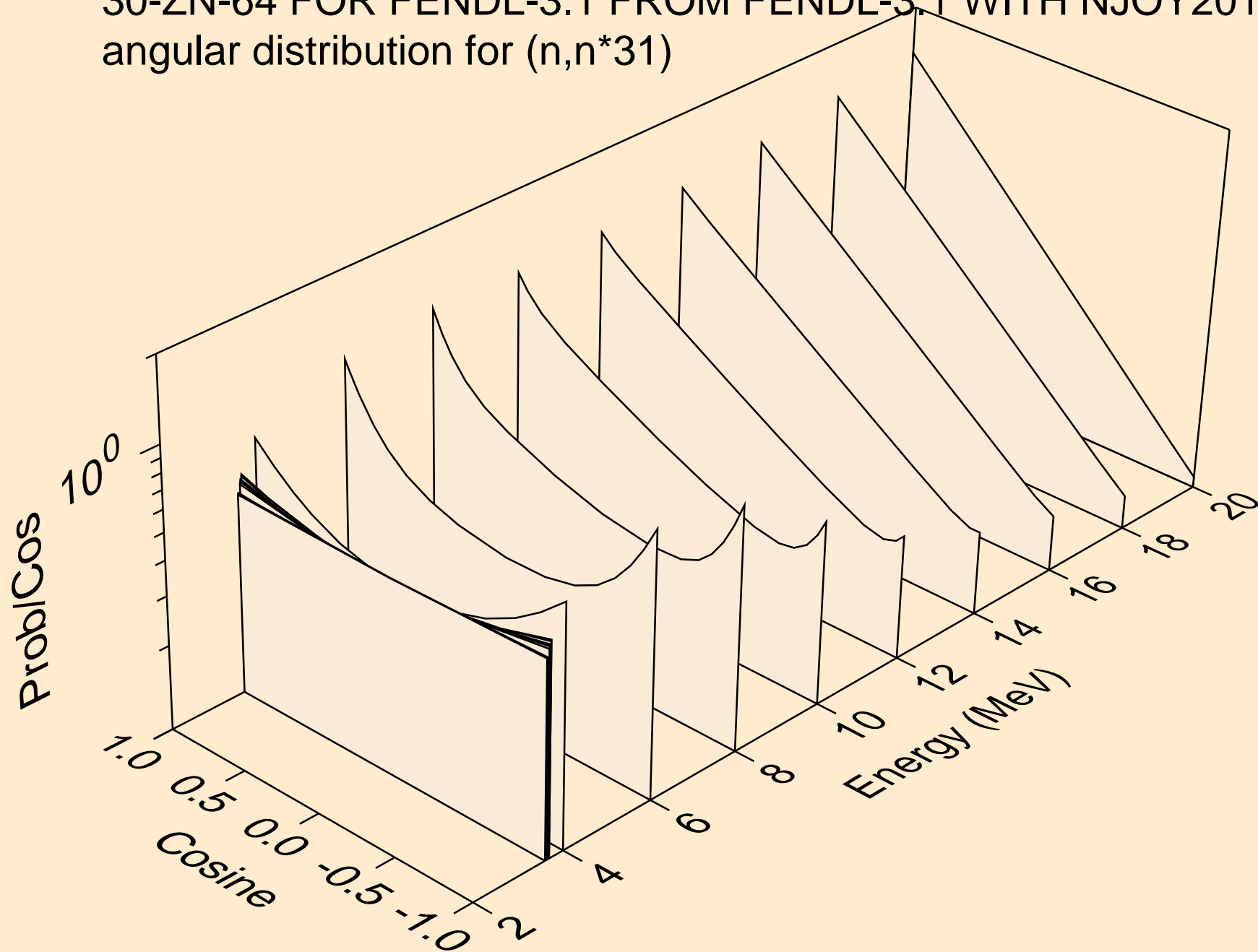

30-ZN-64 FOR FENDL-3.1 FROM FENDL-3.1 WITH NJOY2012.50+
angular distribution for (n,n*32)

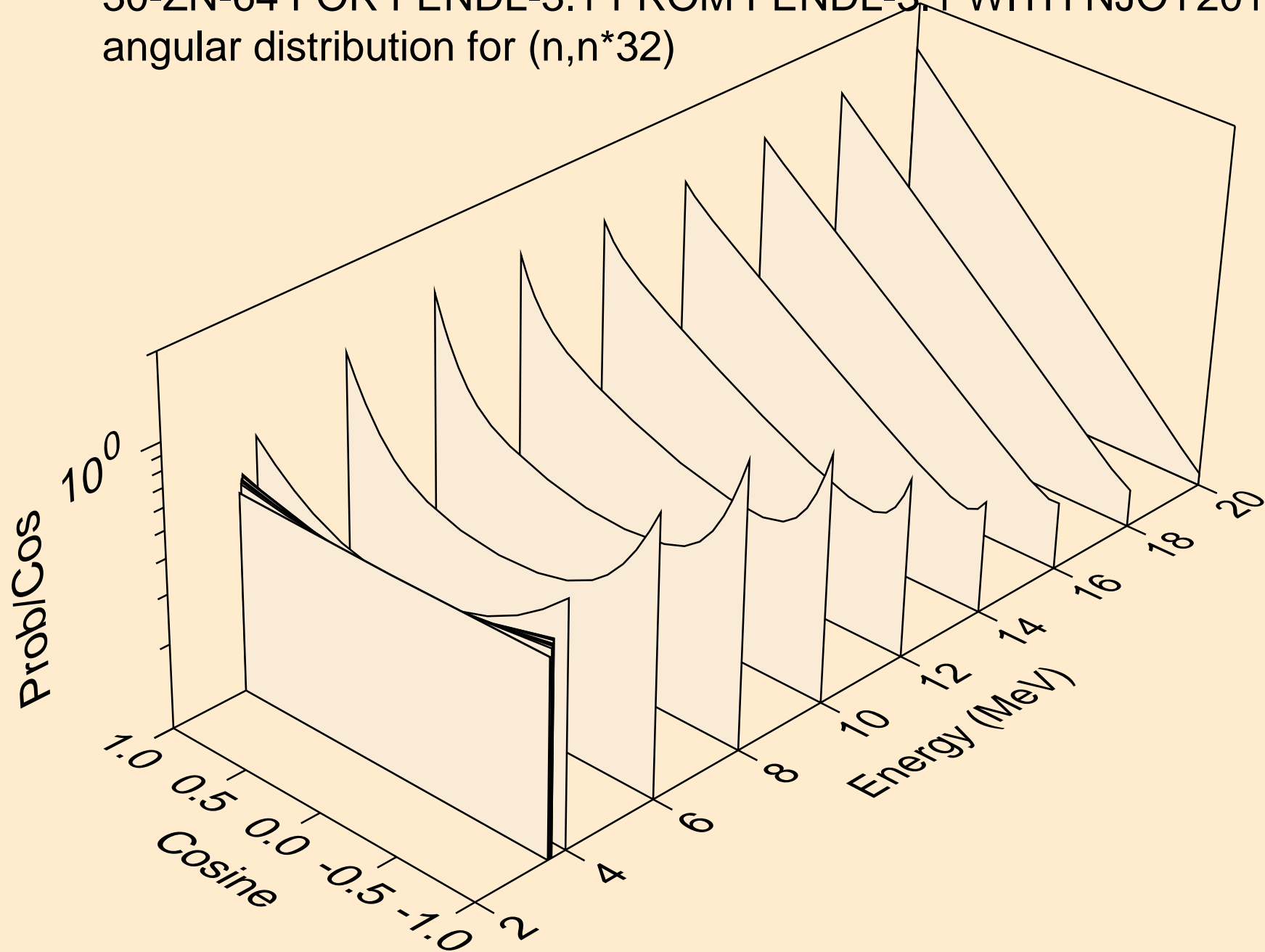

30-ZN-64 FOR FENDL-3.1 FROM FENDL-3.1 WITH NJOY2012.50+
angular distribution for (n,n*33)

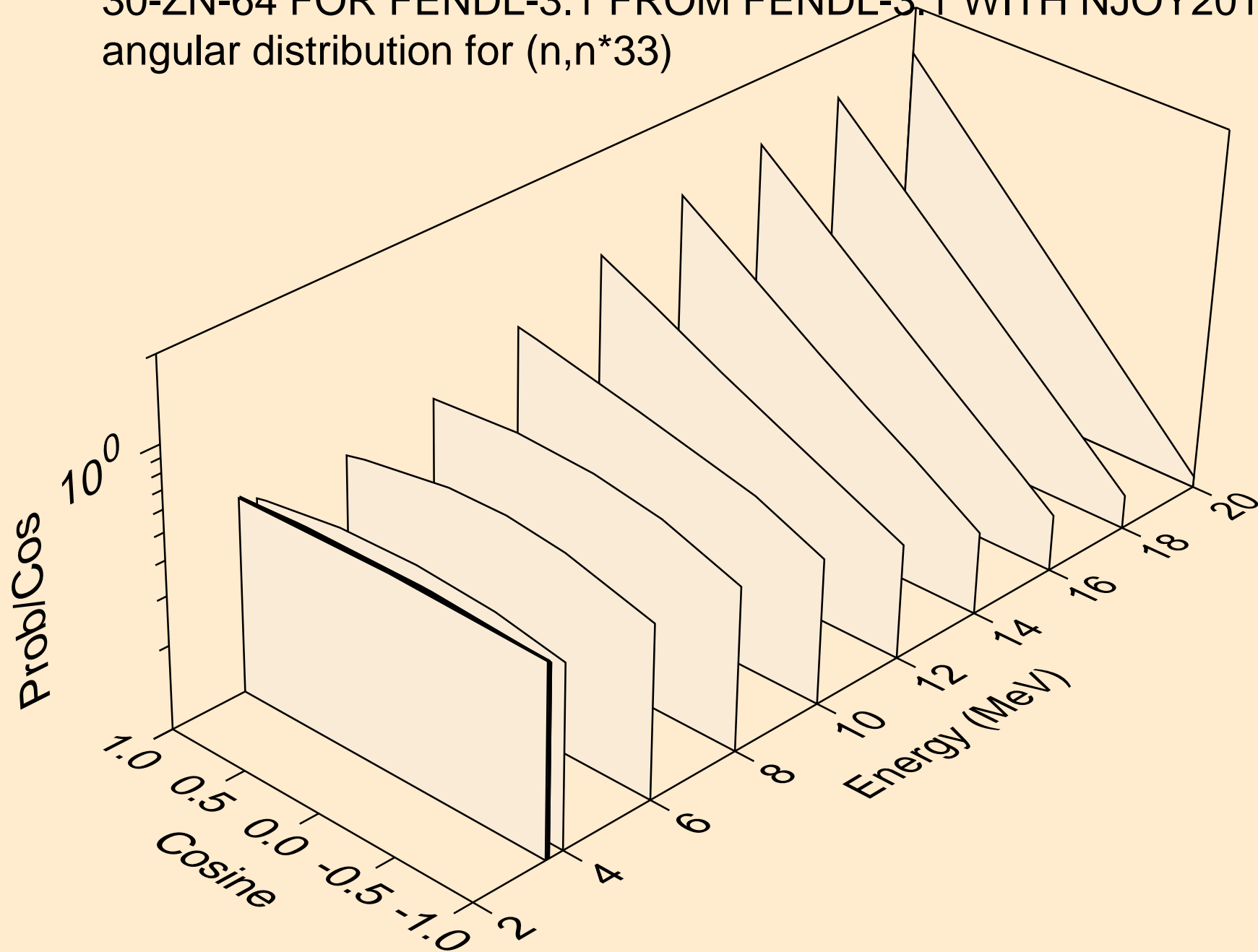

30-ZN-64 FOR FENDL-3.1 FROM FENDL-3.1 WITH NJOY2012.50+
angular distribution for (n,n*34)

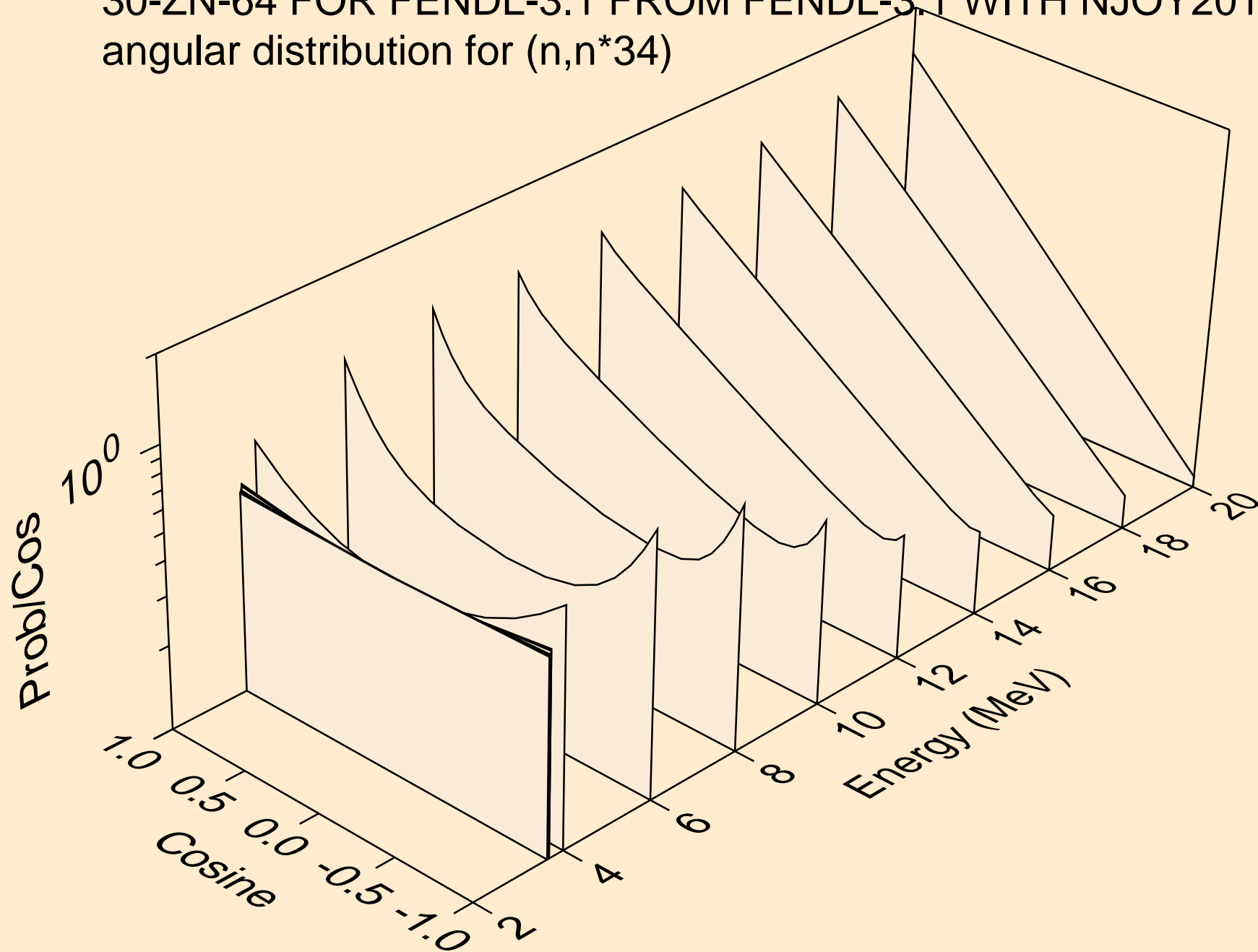

30-ZN-64 FOR FENDL-3.1 FROM FENDL-3.1 WITH NJOY2012.50+
angular distribution for (n,n*35)

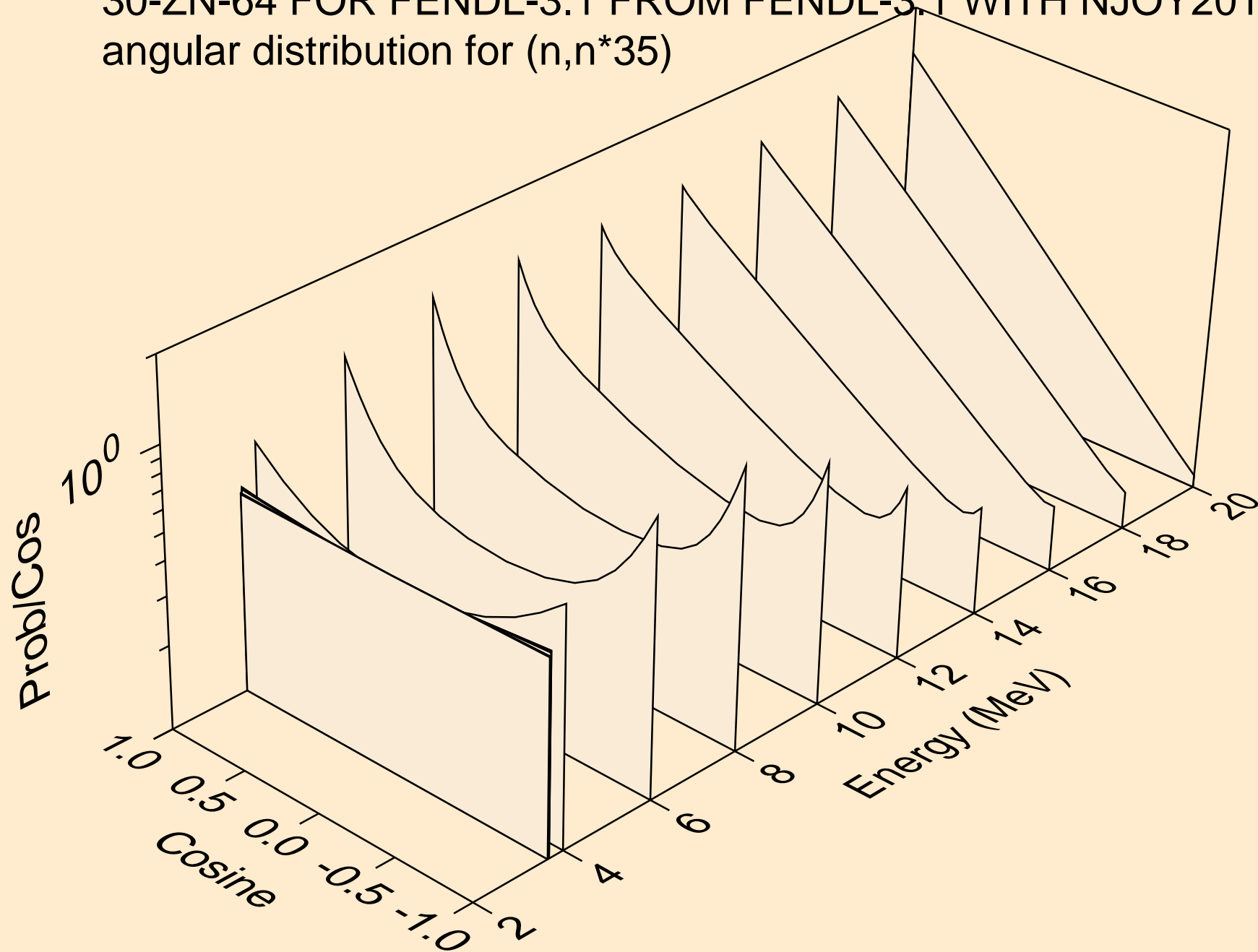

30-ZN-64 FOR FENDL-3.1 FROM FENDL-3.1 WITH NJOY2012.50+
angular distribution for (n,n*36)

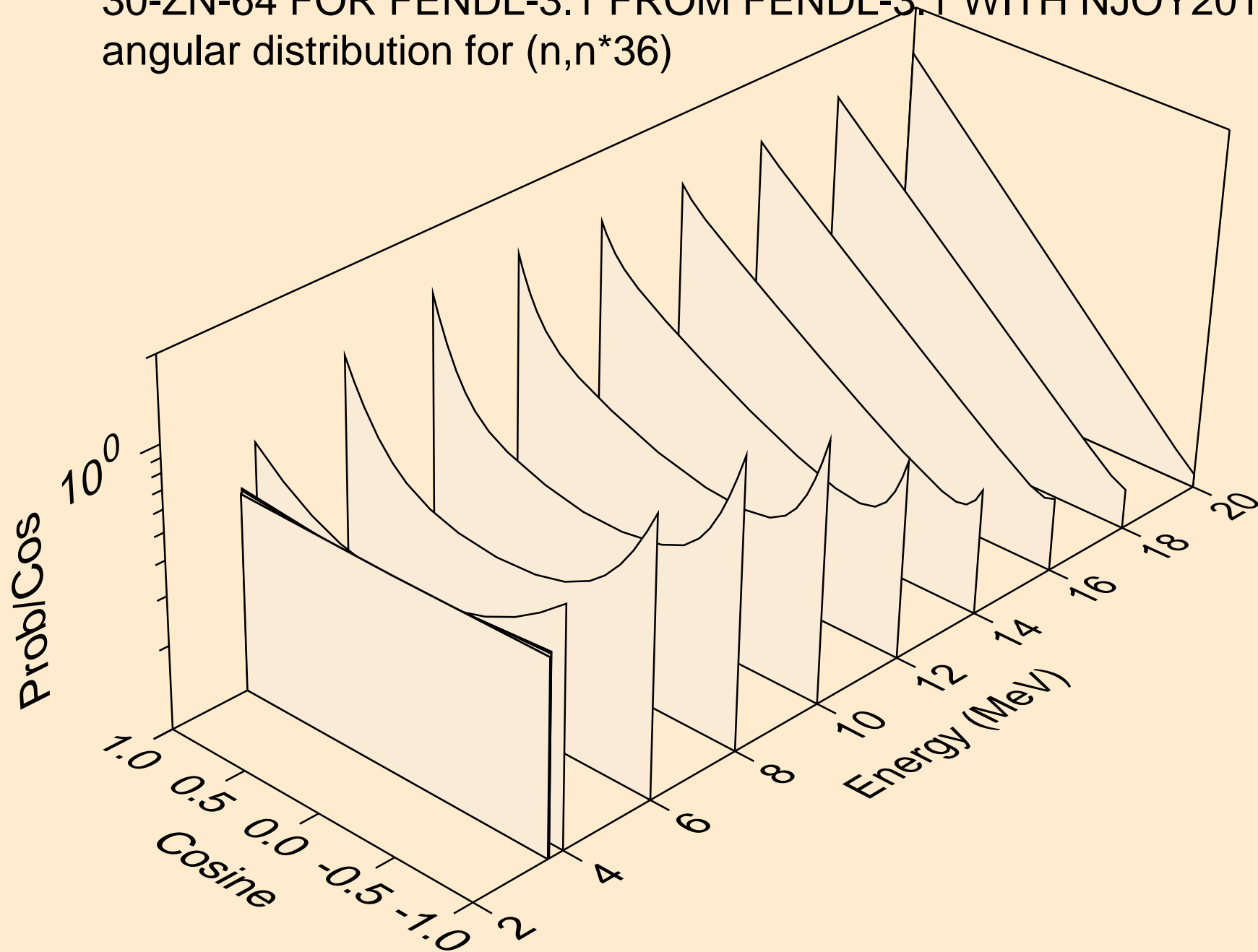

30-ZN-64 FOR FENDL-3.1 FROM FENDL-3.1 WITH NJOY2012.50+
angular distribution for (n,n*37)

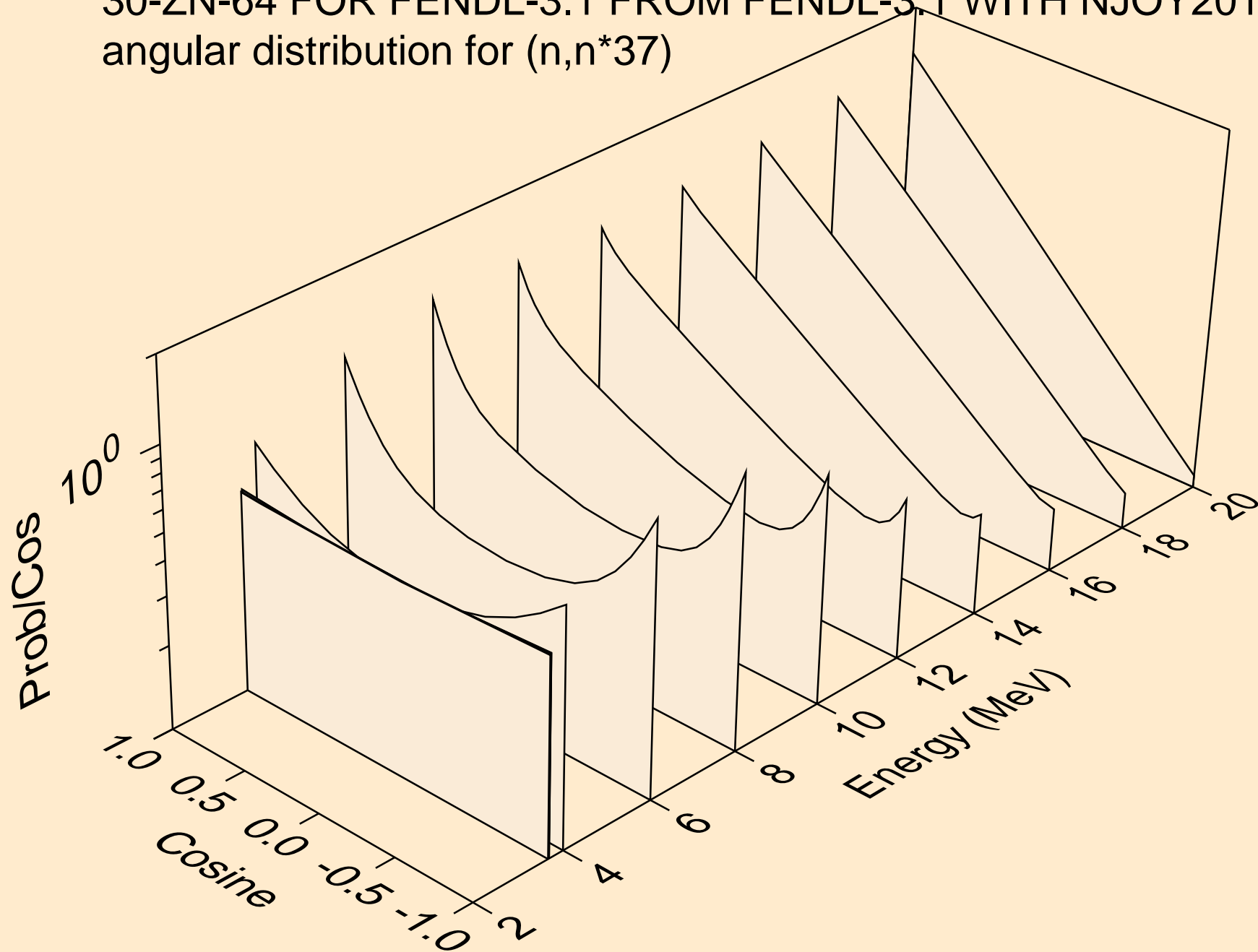

30-ZN-64 FOR FENDL-3.1 FROM FENDL-3.1 WITH NJOY2012.50+
angular distribution for (n,n*38)

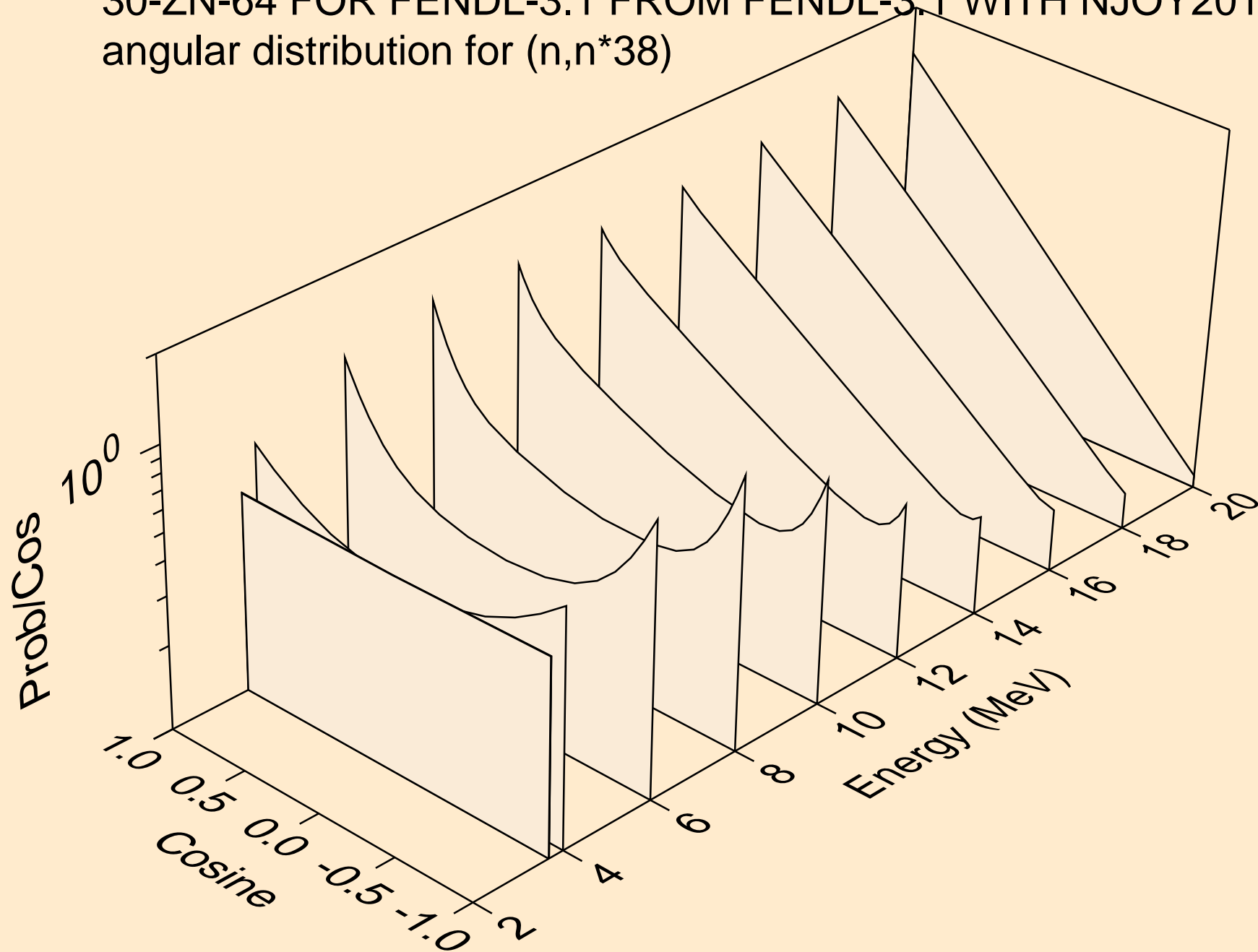

30-ZN-64 FOR FENDL-3.1 FROM FENDL-3.1 WITH NJOY2012.50+
angular distribution for (n,n*39)

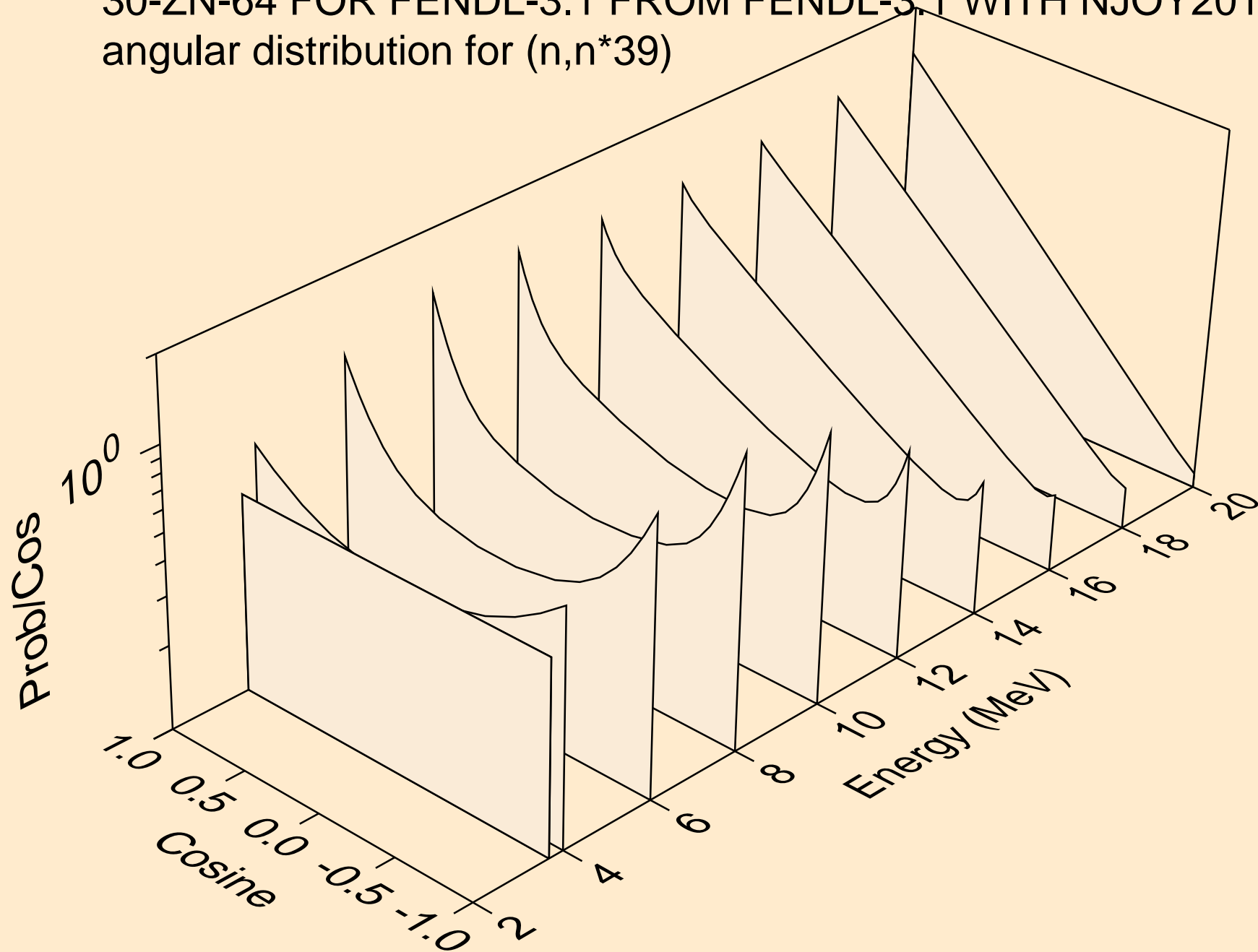

30-ZN-64 FOR FENDL-3.1 FROM FENDL-3.1 WITH NJOY2012.50+
angular distribution for (n,n*40)

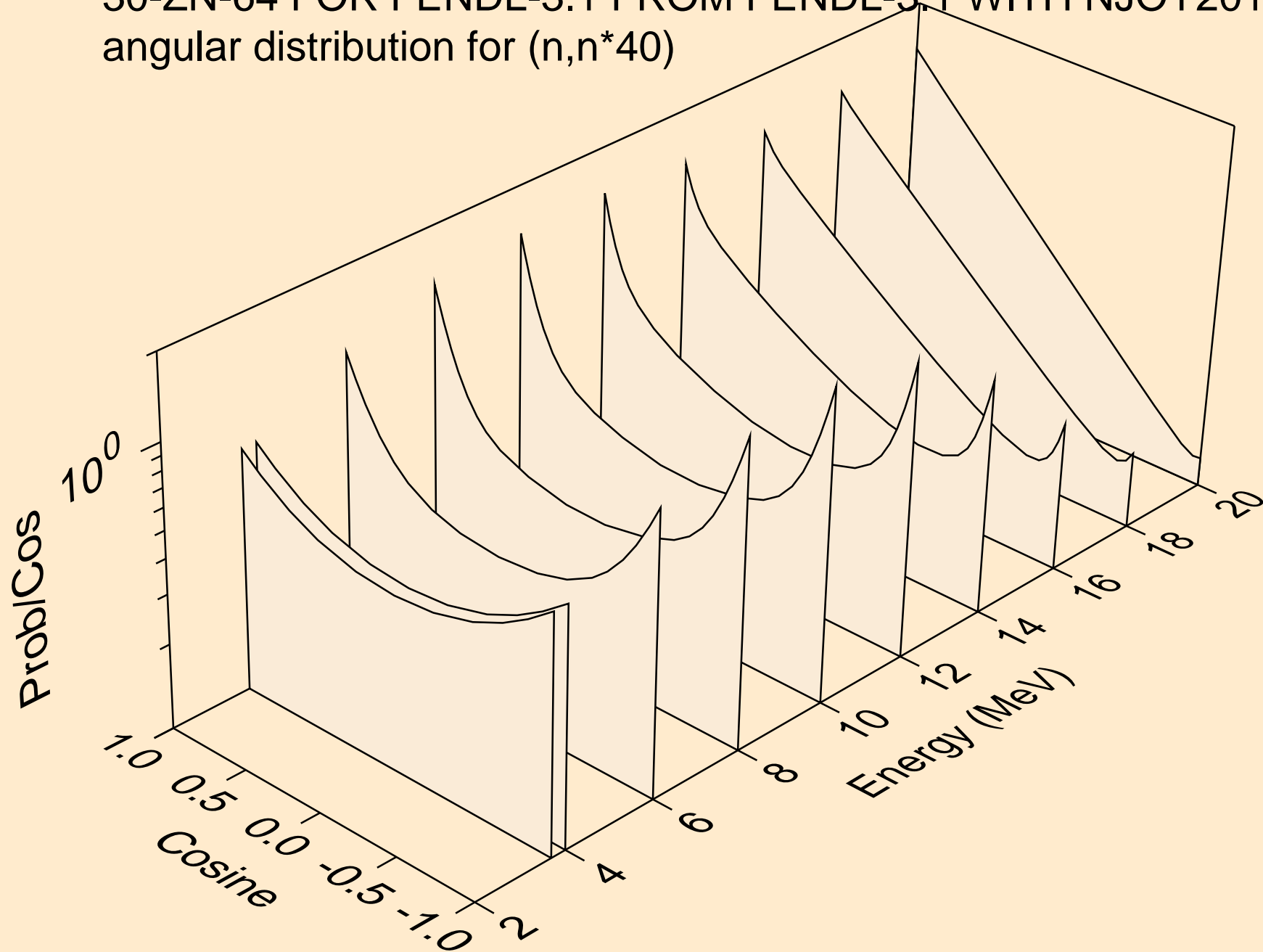

30-ZN-64 FOR FENDL-3.1 FROM FENDL-3.1 WITH NJOY2012.50+
Neutron emission for (n,x)

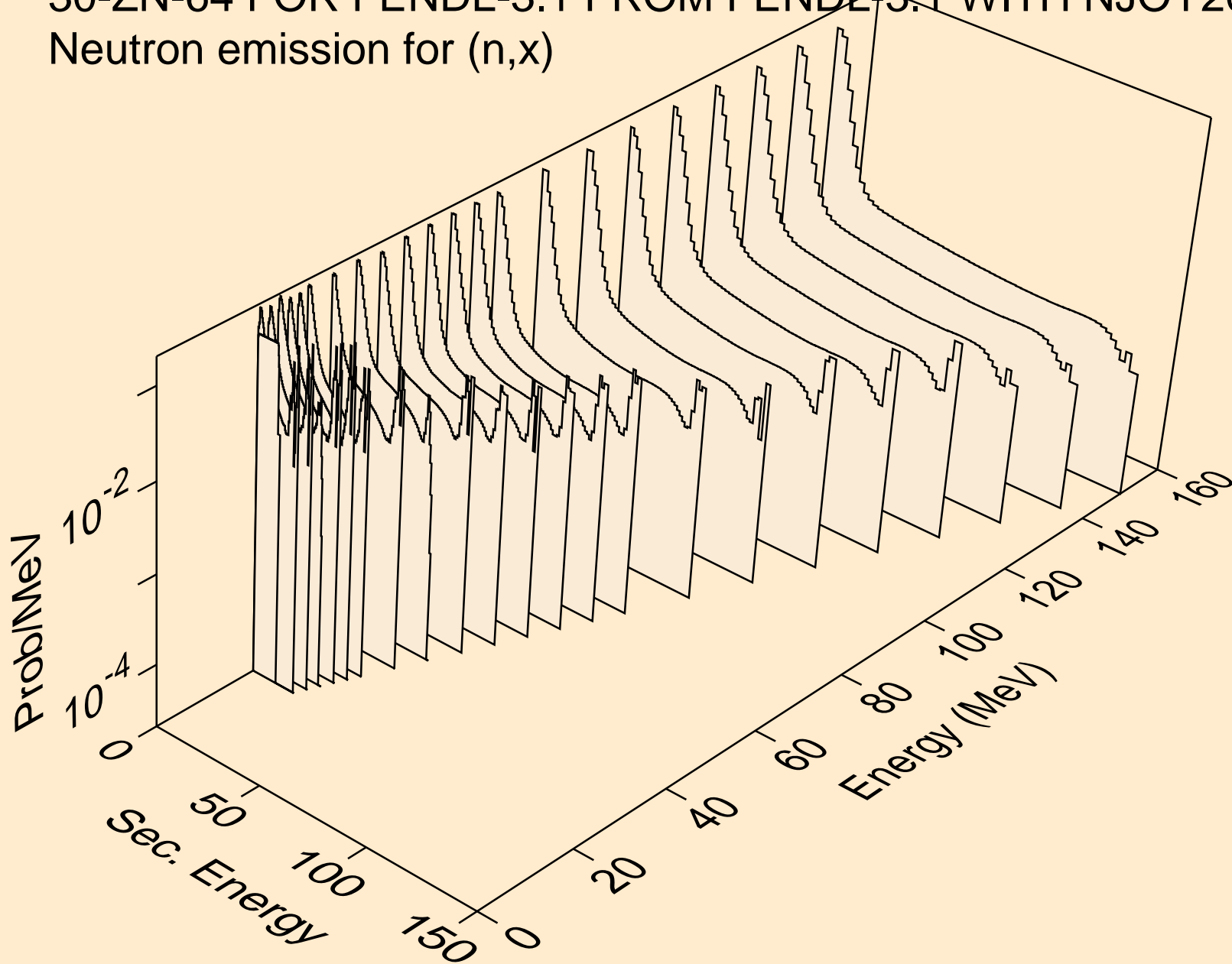

30-ZN-64 FOR FENDL-3.1 FROM FENDL-3.1 WITH NJOY2012.50+
Neutron emission for (n,2n)

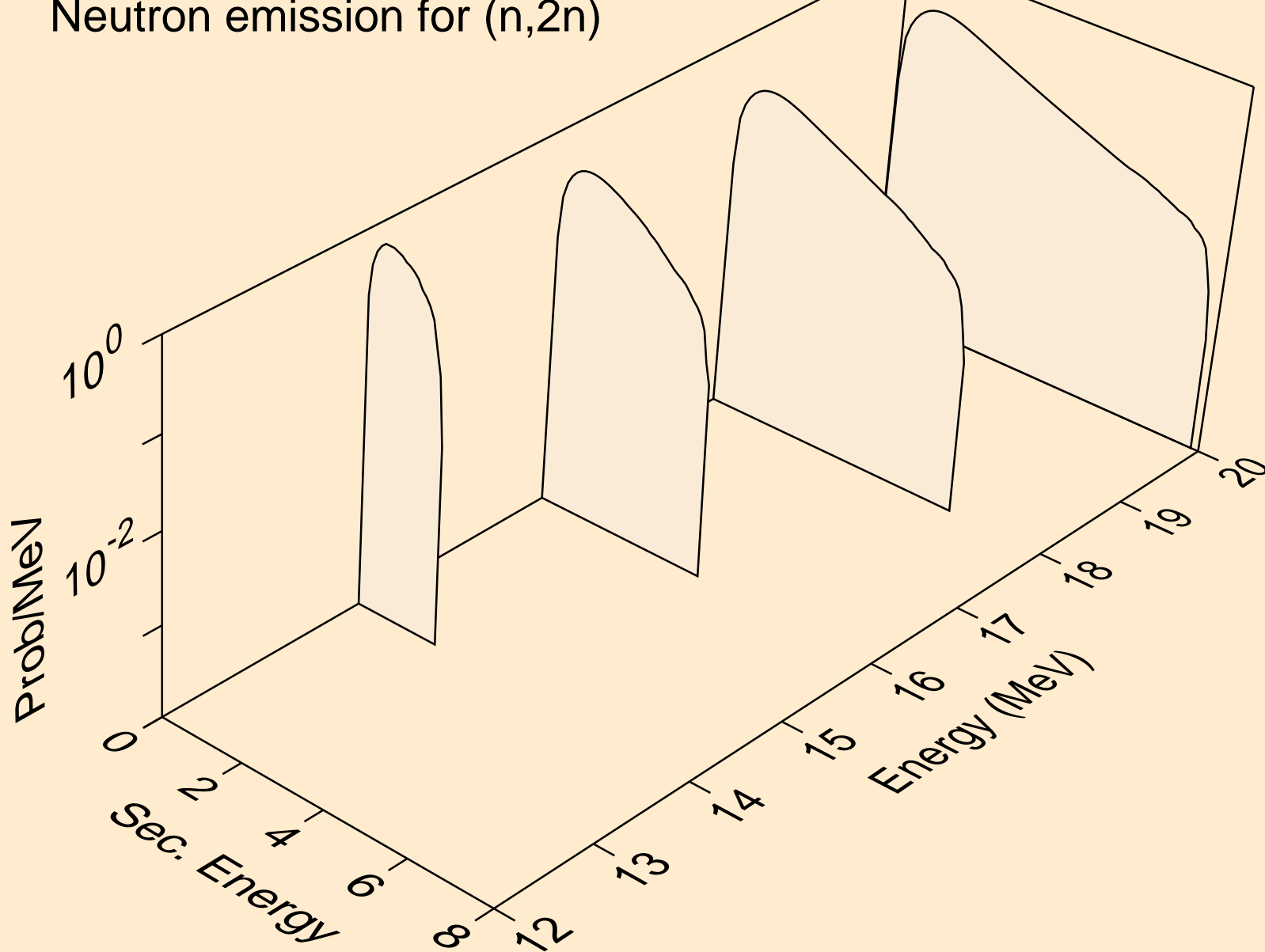

30-ZN-64 FOR FENDL-3.1 FROM FENDL-3.1 WITH NJOY2012.50+
Neutron emission for (n,n*)a

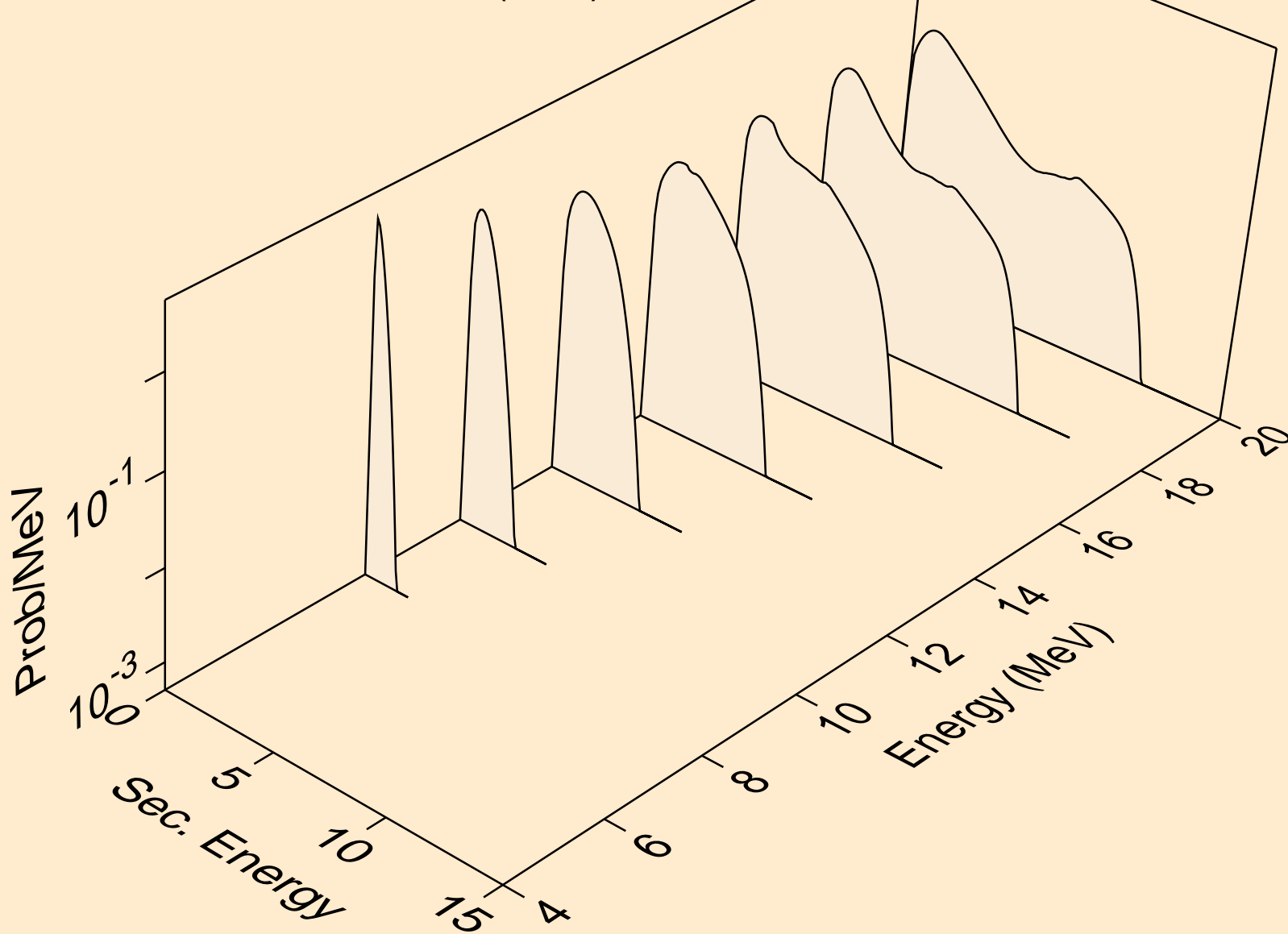

30-ZN-64 FOR FENDL-3.1 FROM FENDL-3.1 WITH NJOY2012.50+
Neutron emission for (n,2n)a

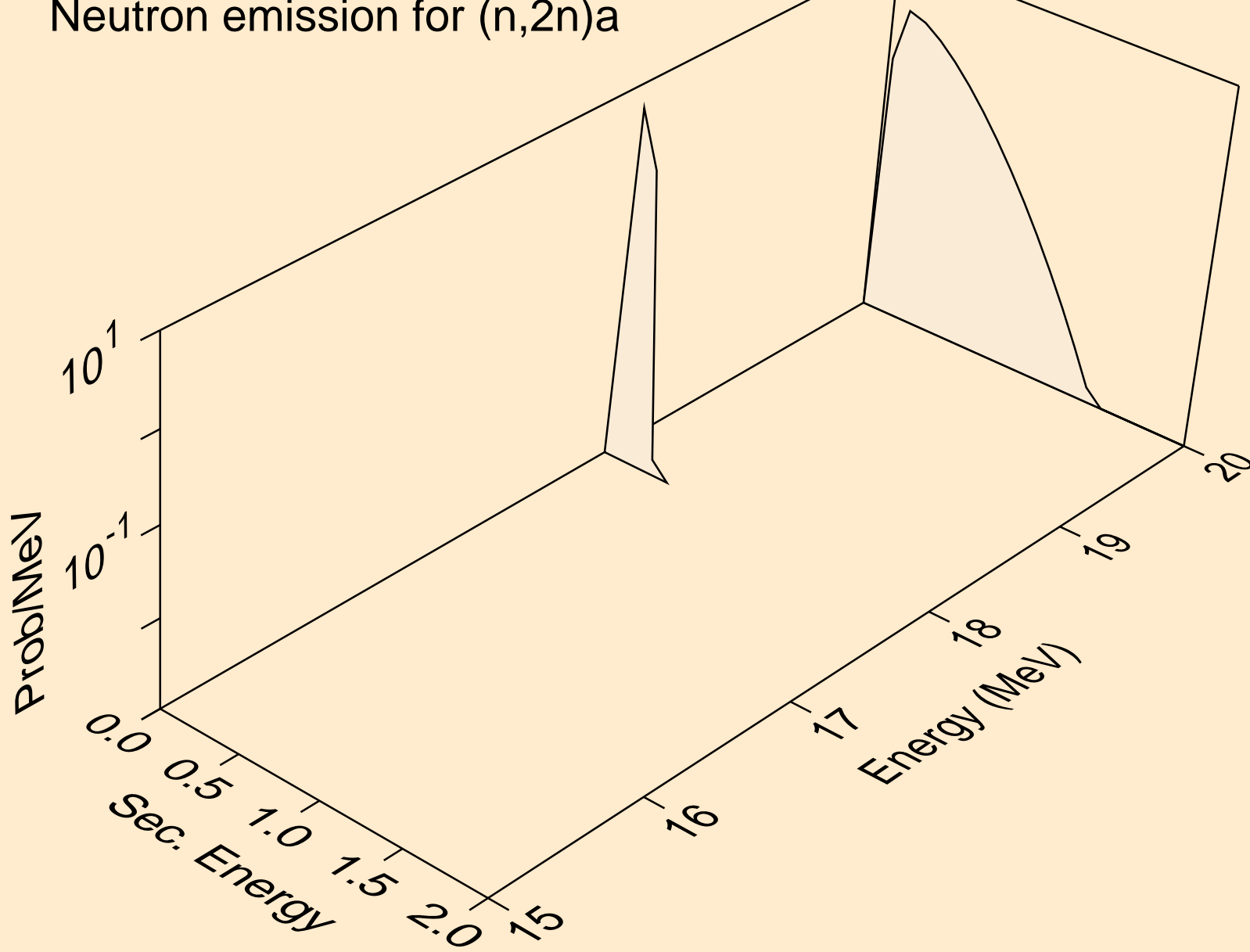

30-ZN-64 FOR FENDL-3.1 FROM FENDL-3.1 WITH NJOY2012.50+
Neutron emission for (n,n*)p

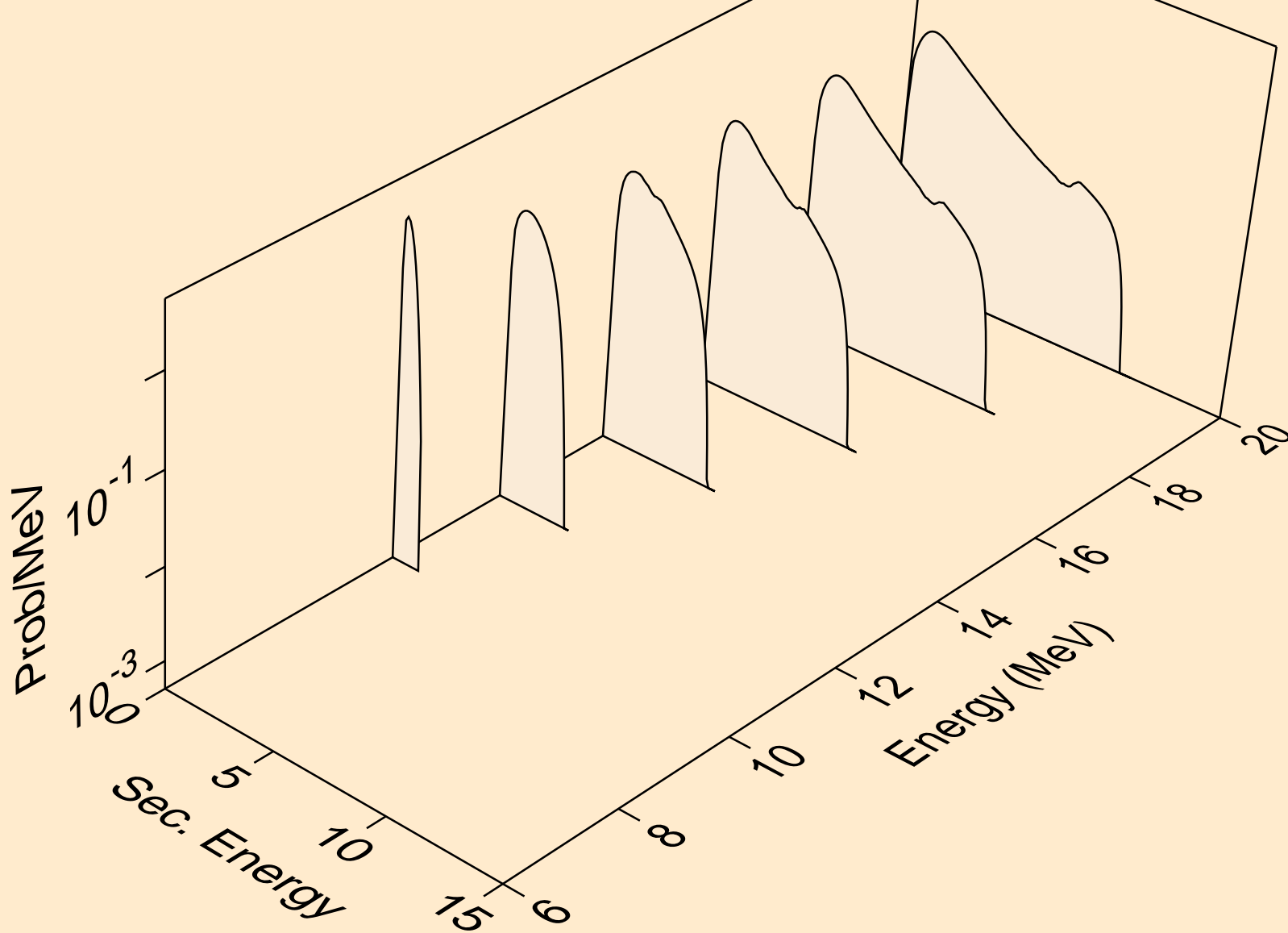

30-ZN-64 FOR FENDL-3.1 FROM FENDL-3.1 WITH NJOY2012.50+
Neutron emission for (n,n*)d

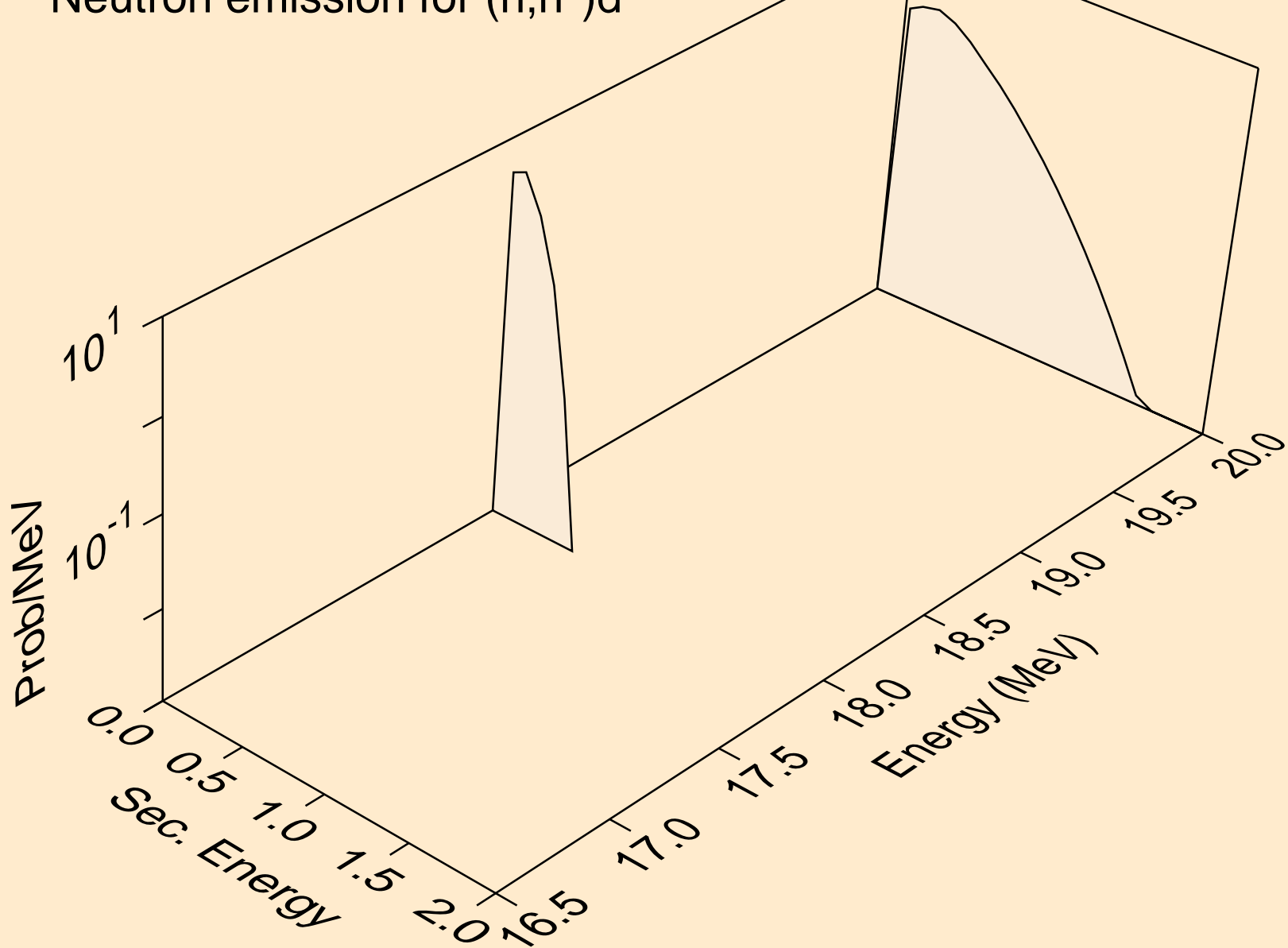

30-ZN-64 FOR FENDL-3.1 FROM FENDL-3.1 WITH NJOY2012.50+
Neutron emission for (n,2np)

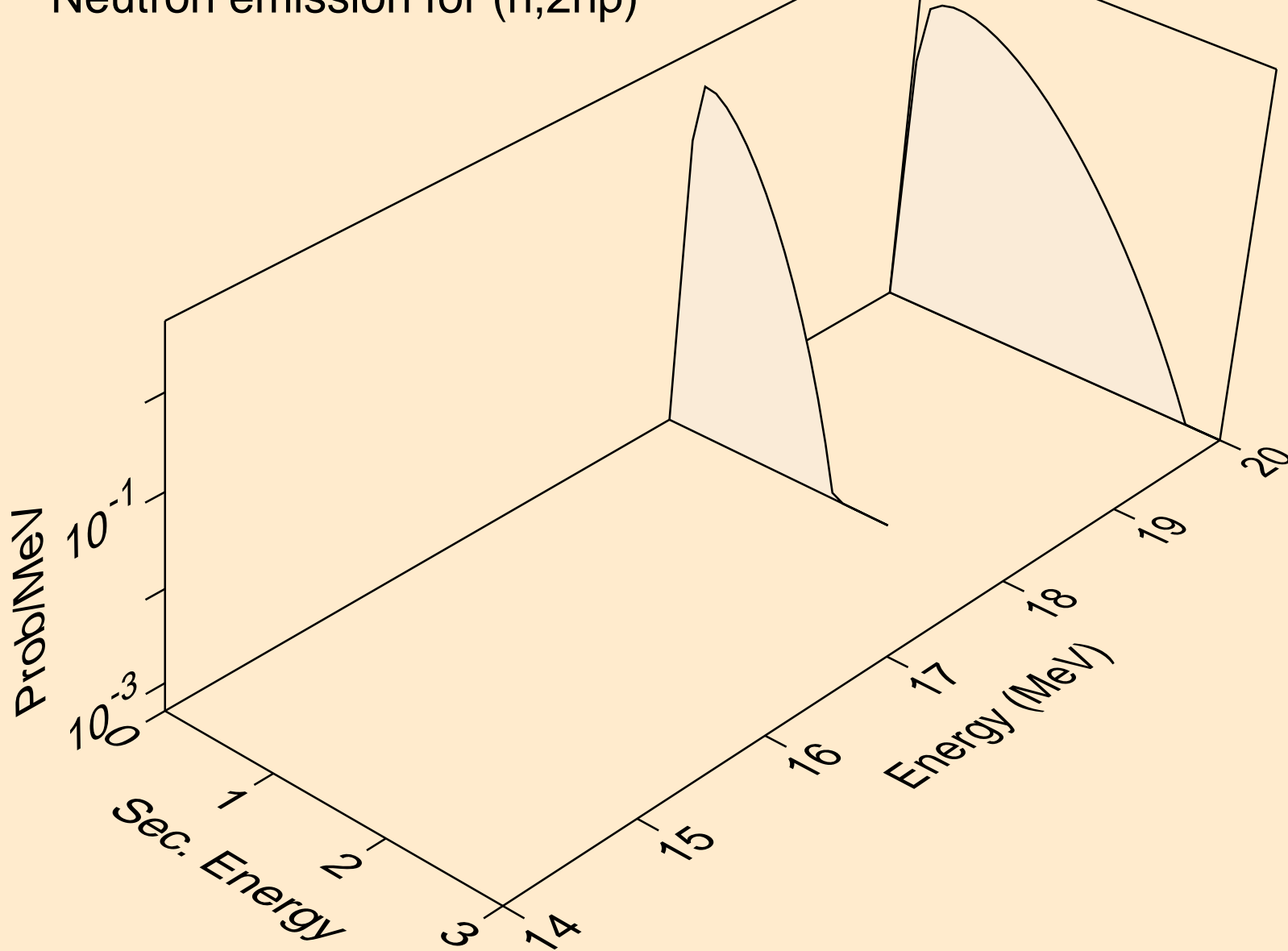

30-ZN-64 FOR FENDL-3.1 FROM FENDL-3.1 WITH NJOY2012.50+
Neutron emission for (n,n*c)

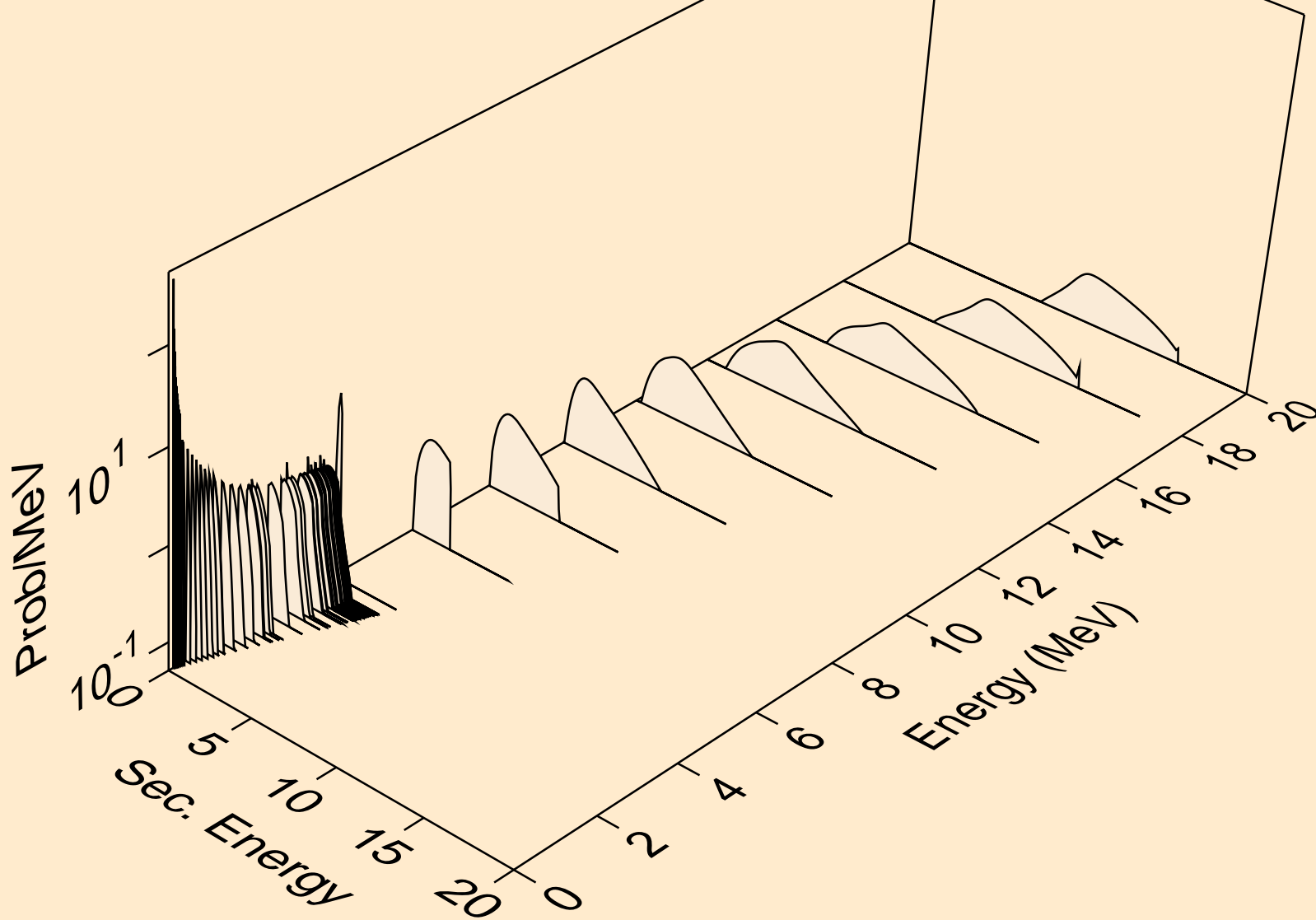

30-ZN-64 FOR FENDL-3.1 FROM FENDL-3.1 WITH NJOY2012.50+
Photon emission for (n,x)

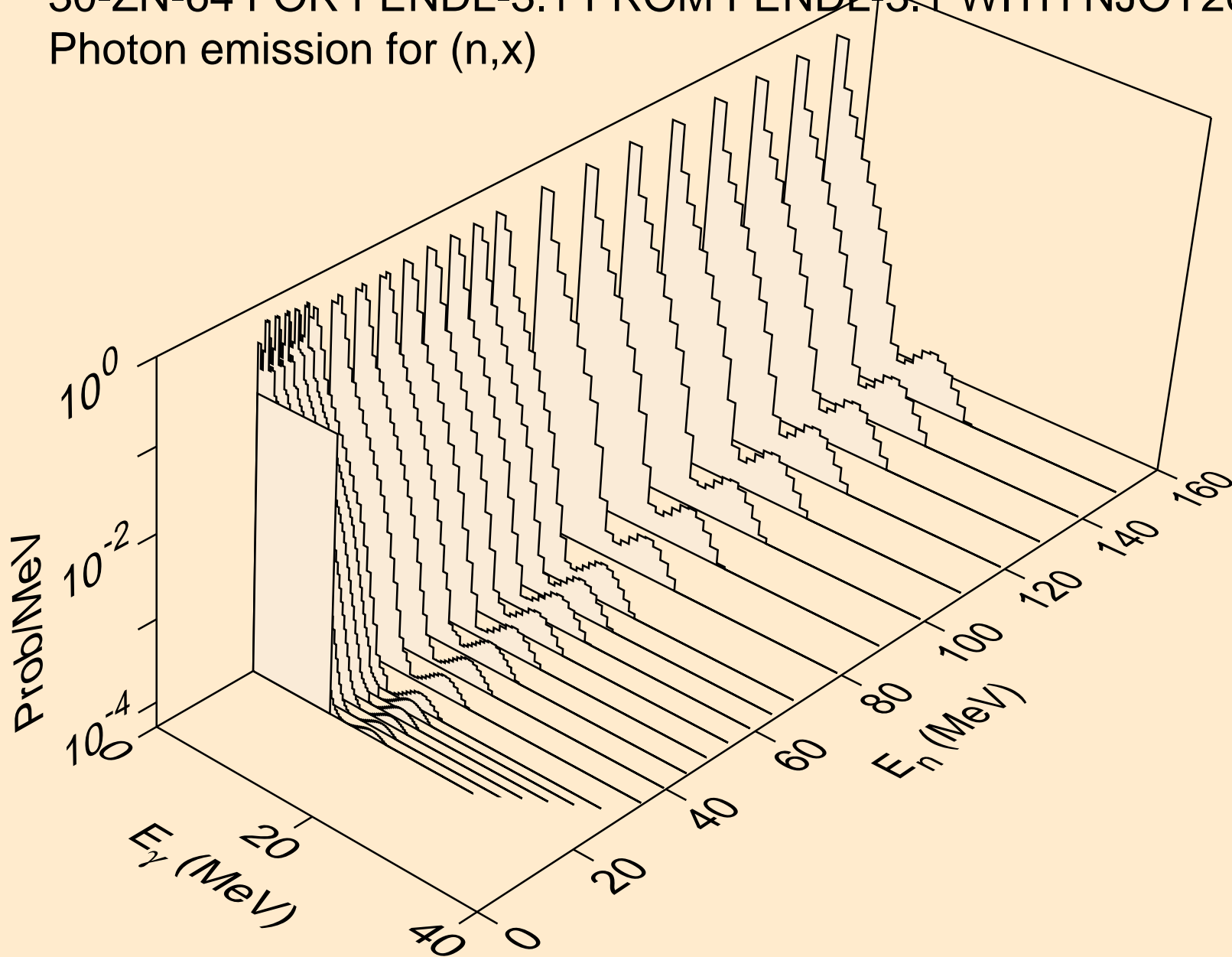

30-ZN-64 FOR FENDL-3.1 FROM FENDL-3.1 WITH NJOY2012.50+
Photon emission for (n,2n)

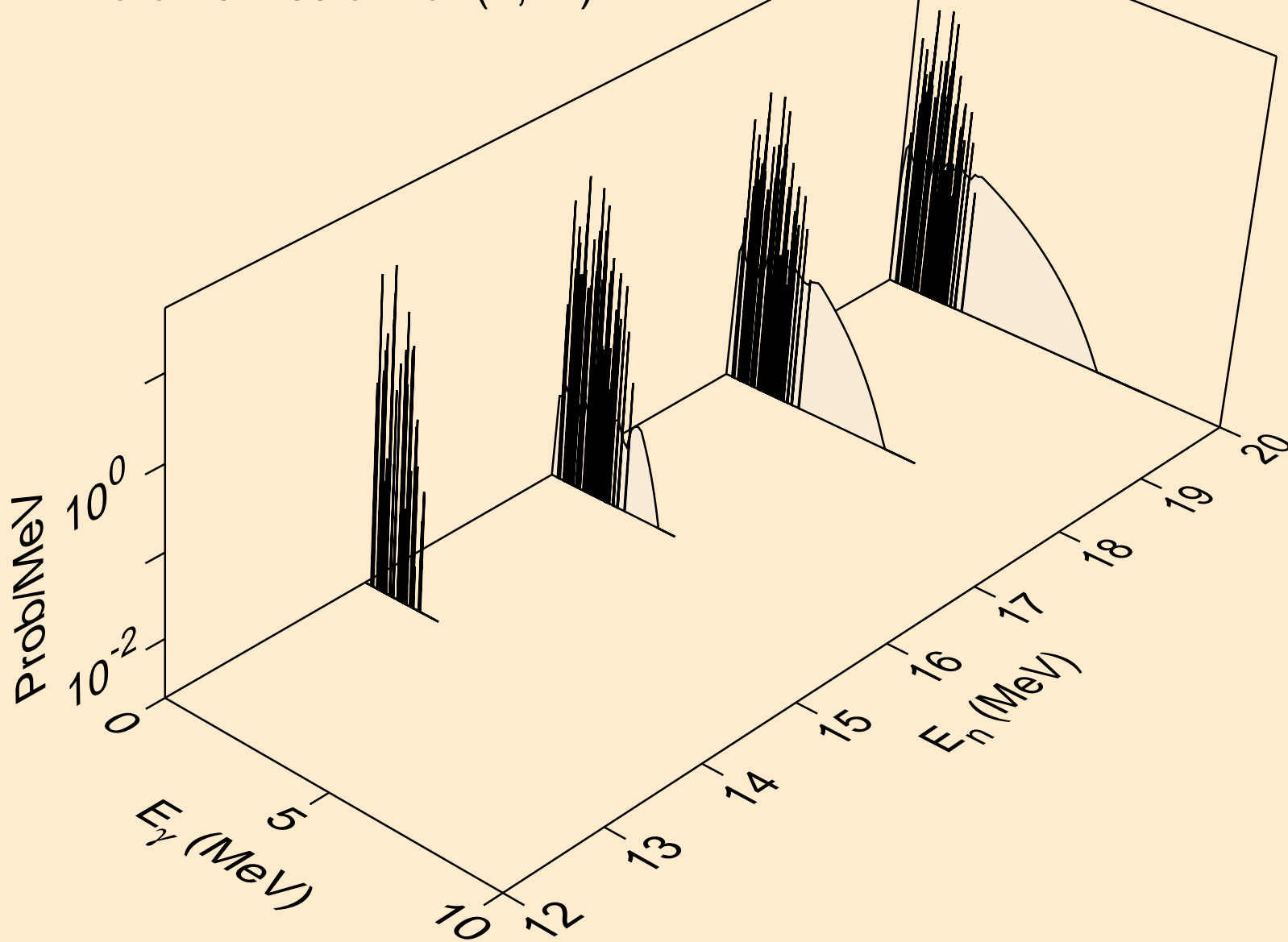

30-ZN-64 FOR FENDL-3.1 FROM FENDL-3.1 WITH NJOY2012.50+
Photon emission for (n,n*)a

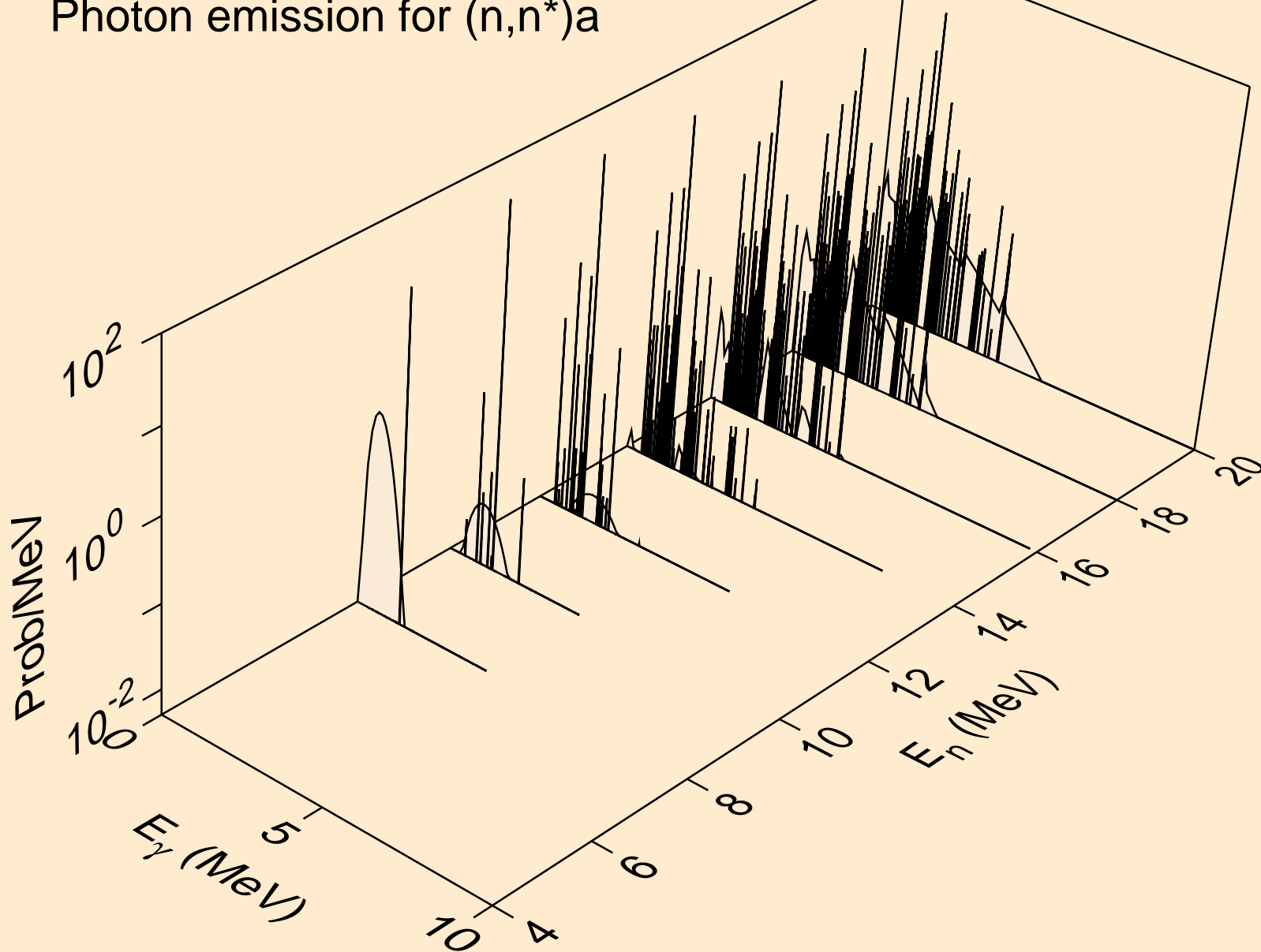

30-ZN-64 FOR FENDL-3.1 FROM FENDL-3.1 WITH NJOY2012.50+
Photon emission for (n,2n)a

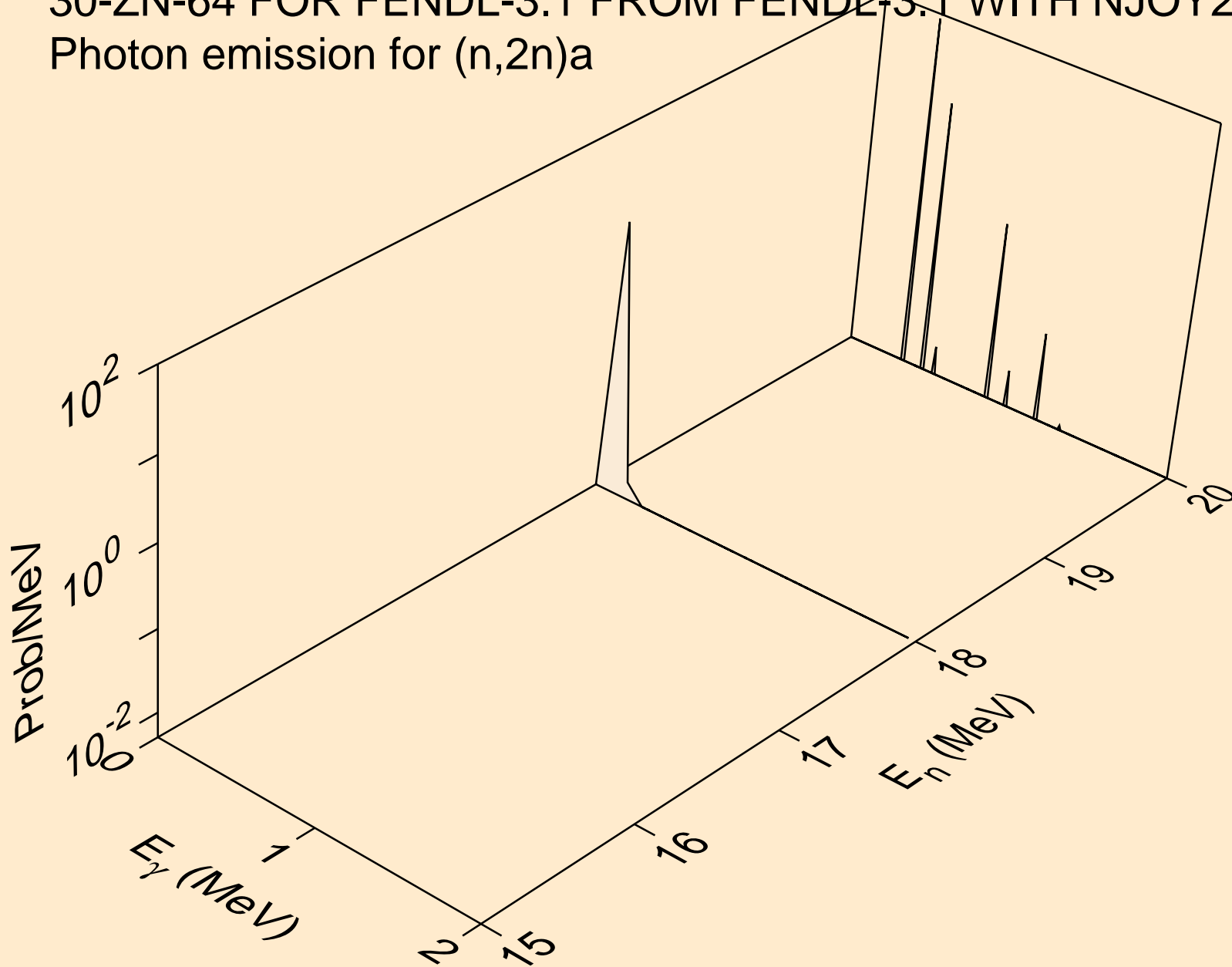

30-ZN-64 FOR FENDL-3.1 FROM FENDL-3.1 WITH NJOY2012.50+
Photon emission for (n,n*)p

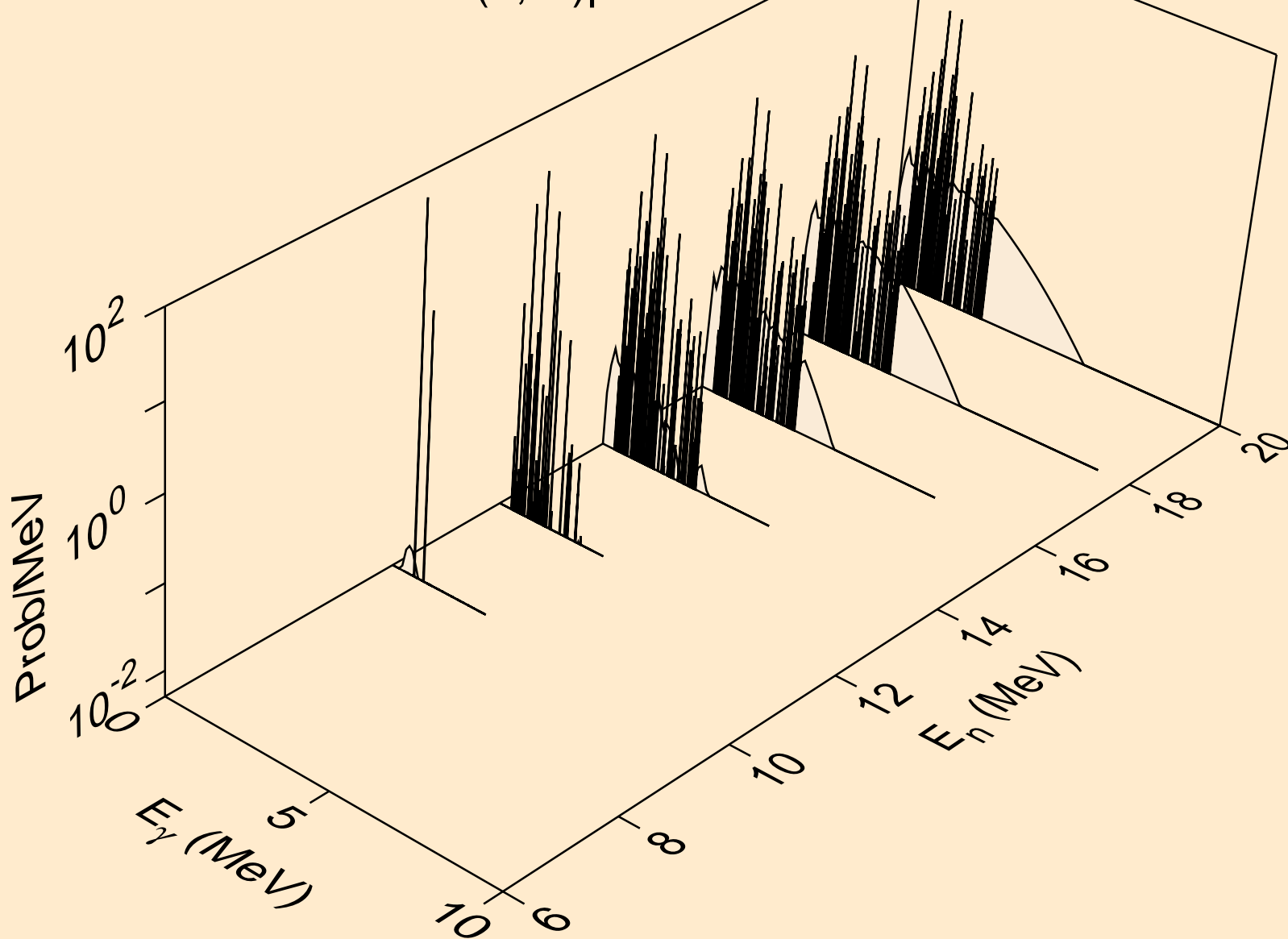

30-ZN-64 FOR FENDL-3.1 FROM FENDL-3.1 WITH NJOY2012.50+
Photon emission for (n,n*)d

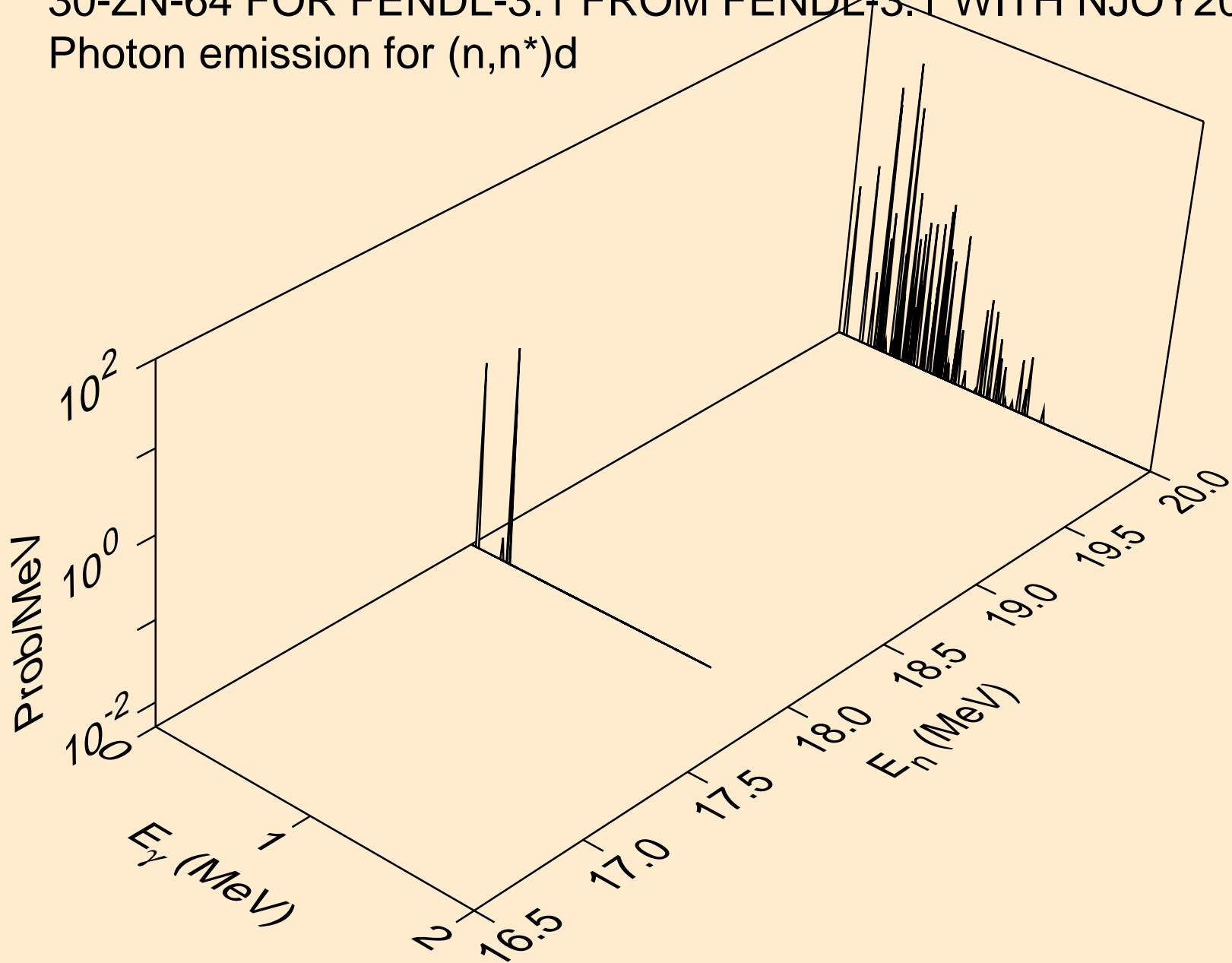

30-ZN-64 FOR FENDL-3.1 FROM FENDL-3.1 WITH NJOY2012.50+
Photon emission for (n,2np)

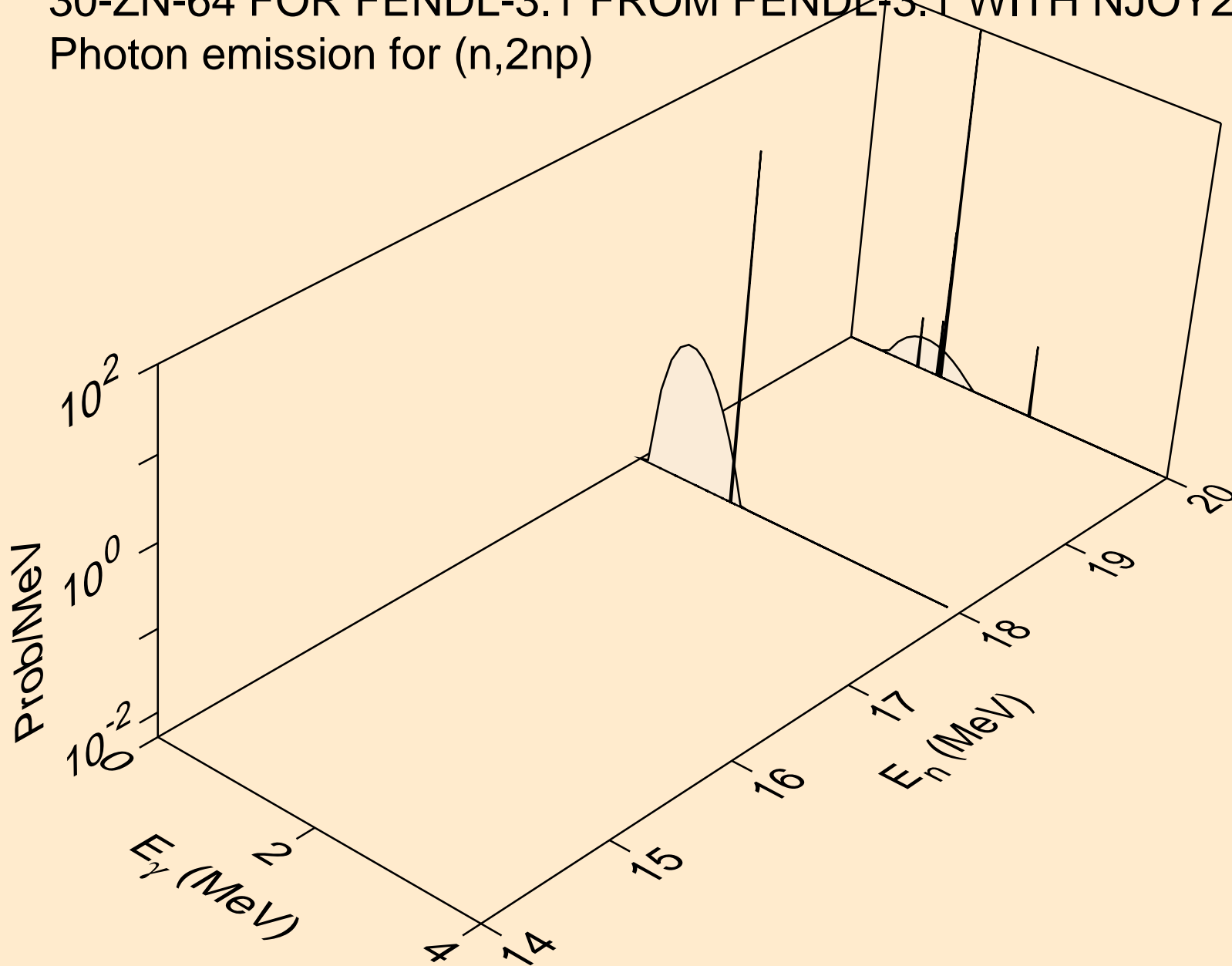

30-ZN-64 FOR FENDL-3.1 FROM FENDL-3.1 WITH NJOY2012.50+
Photon emission for (n,n*1)

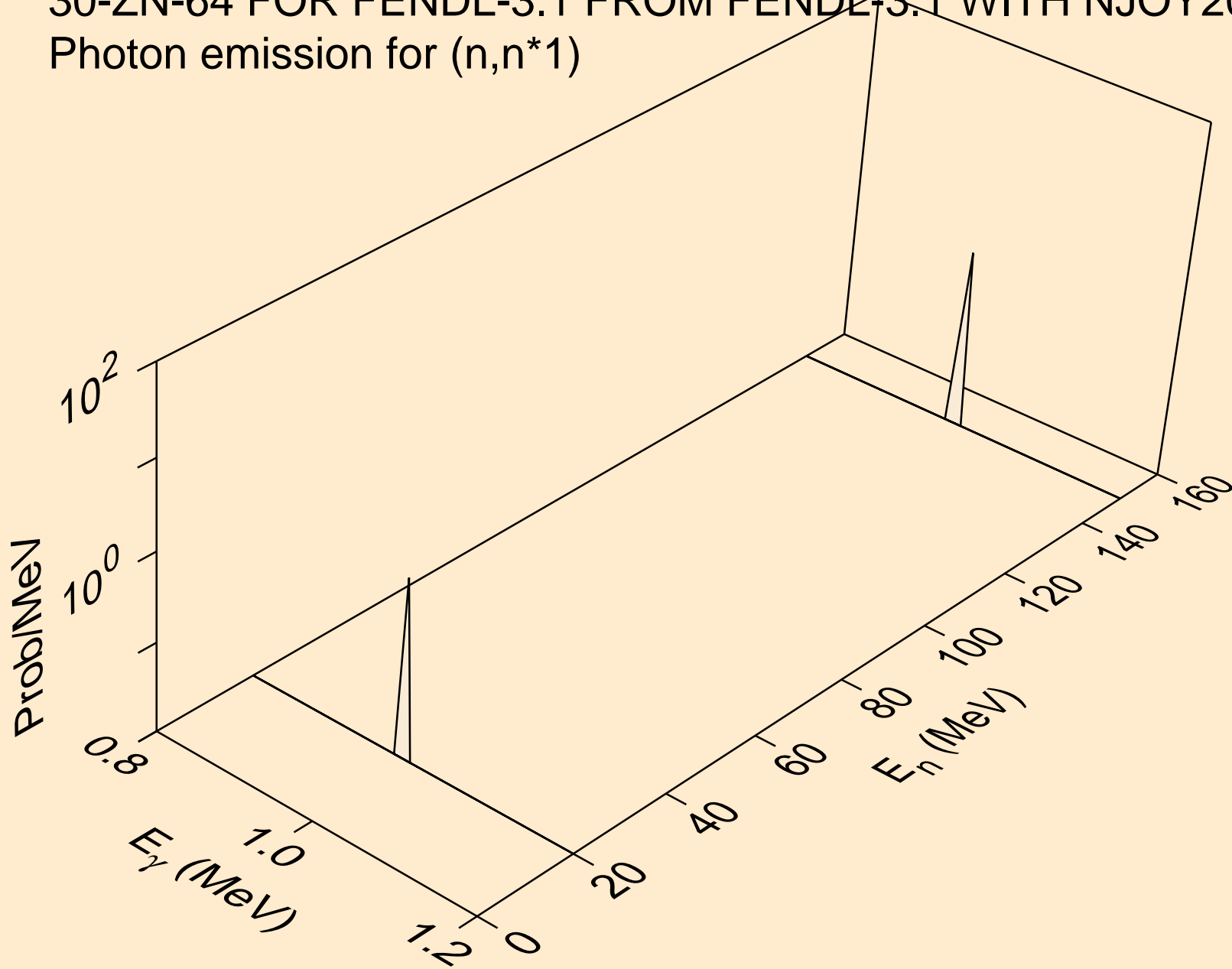

30-ZN-64 FOR FENDL-3.1 FROM FENDL-3.1 WITH NJOY2012.50+
Photon emission for (n,n*2)

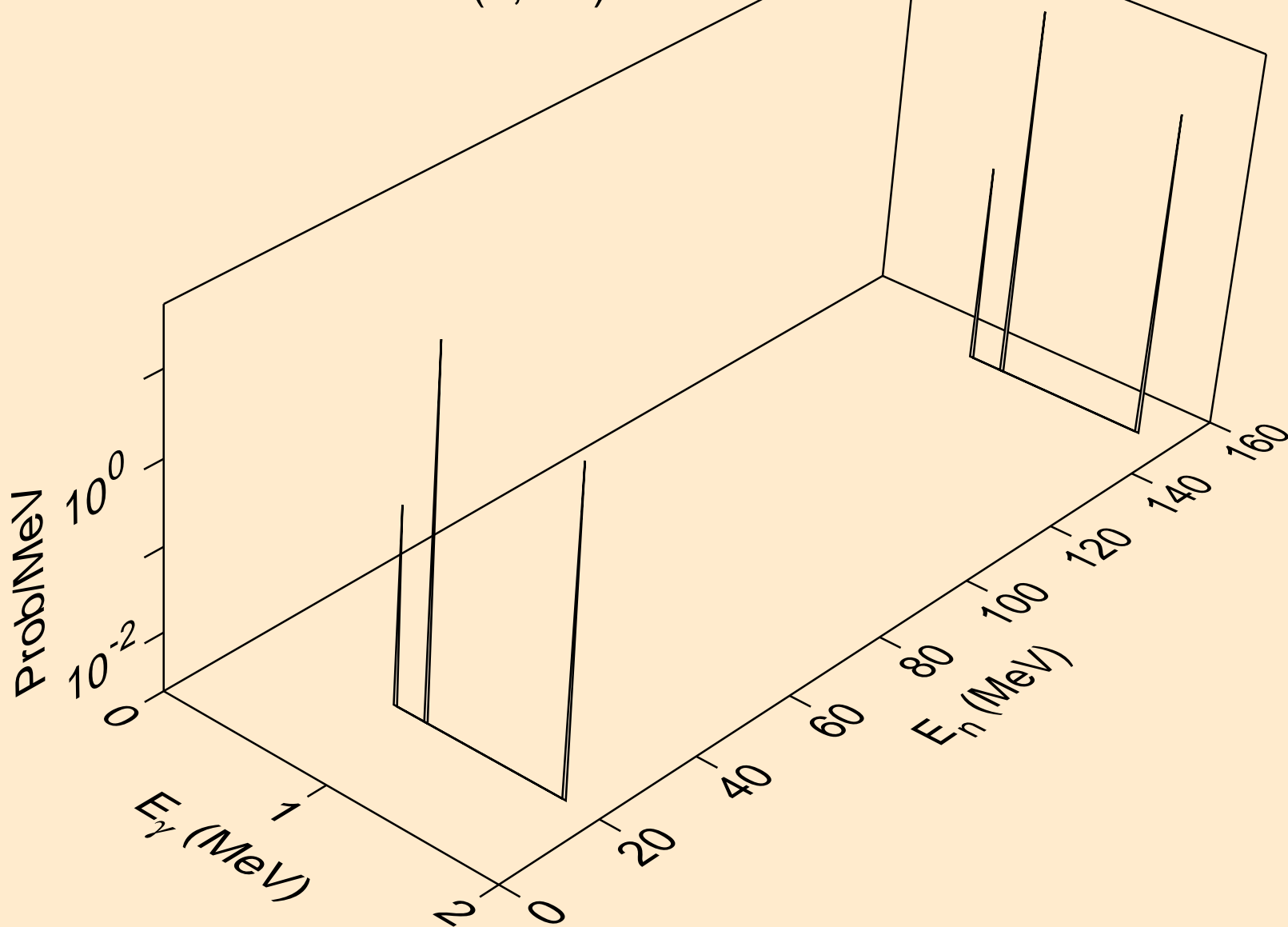

30-ZN-64 FOR FENDL-3.1 FROM FENDL-3.1 WITH NJOY2012.50+
Photon emission for (n,n*3)

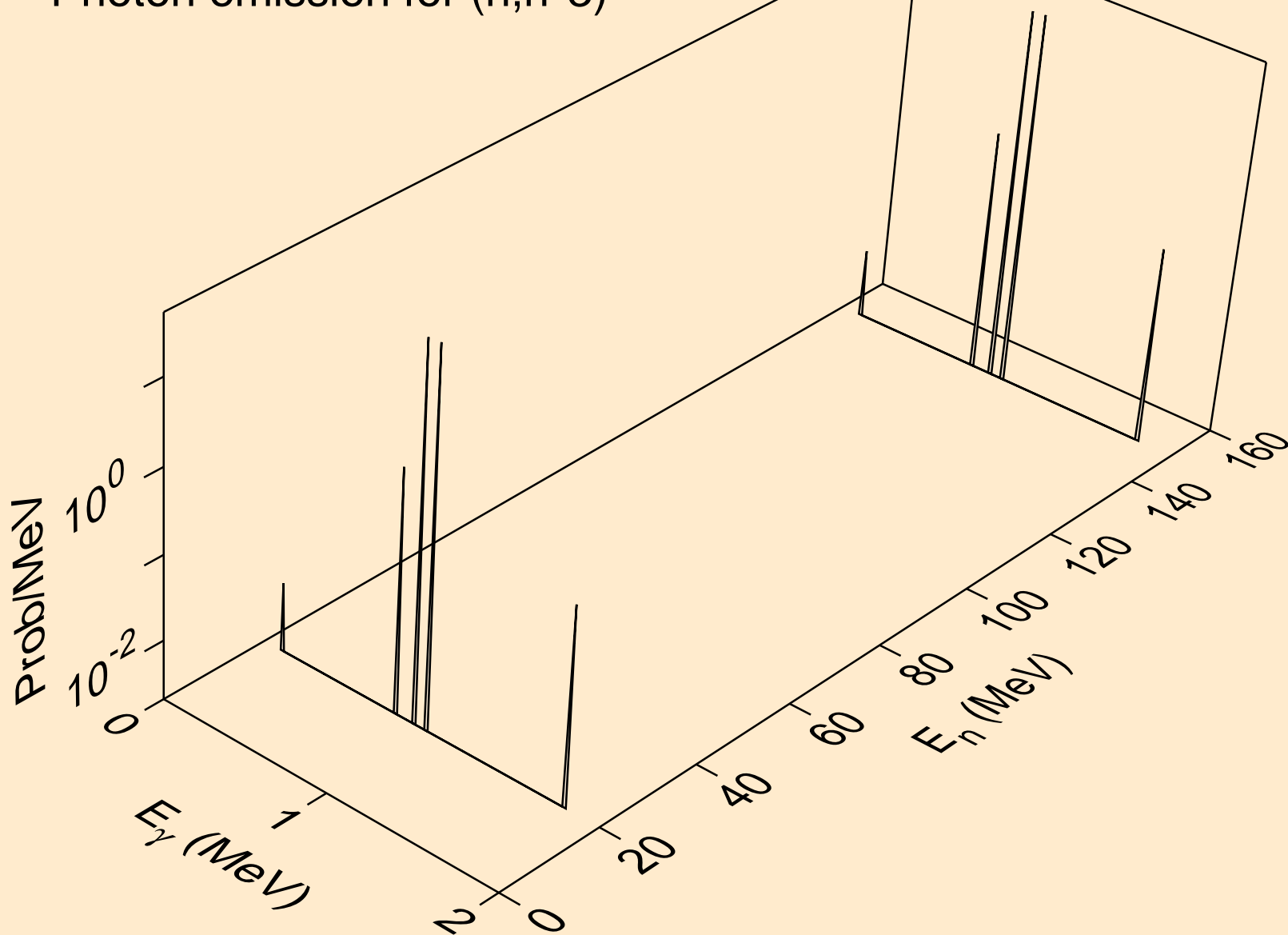

30-ZN-64 FOR FENDL-3.1 FROM FENDL-3.1 WITH NJOY2012.50+
Photon emission for (n,n*4)

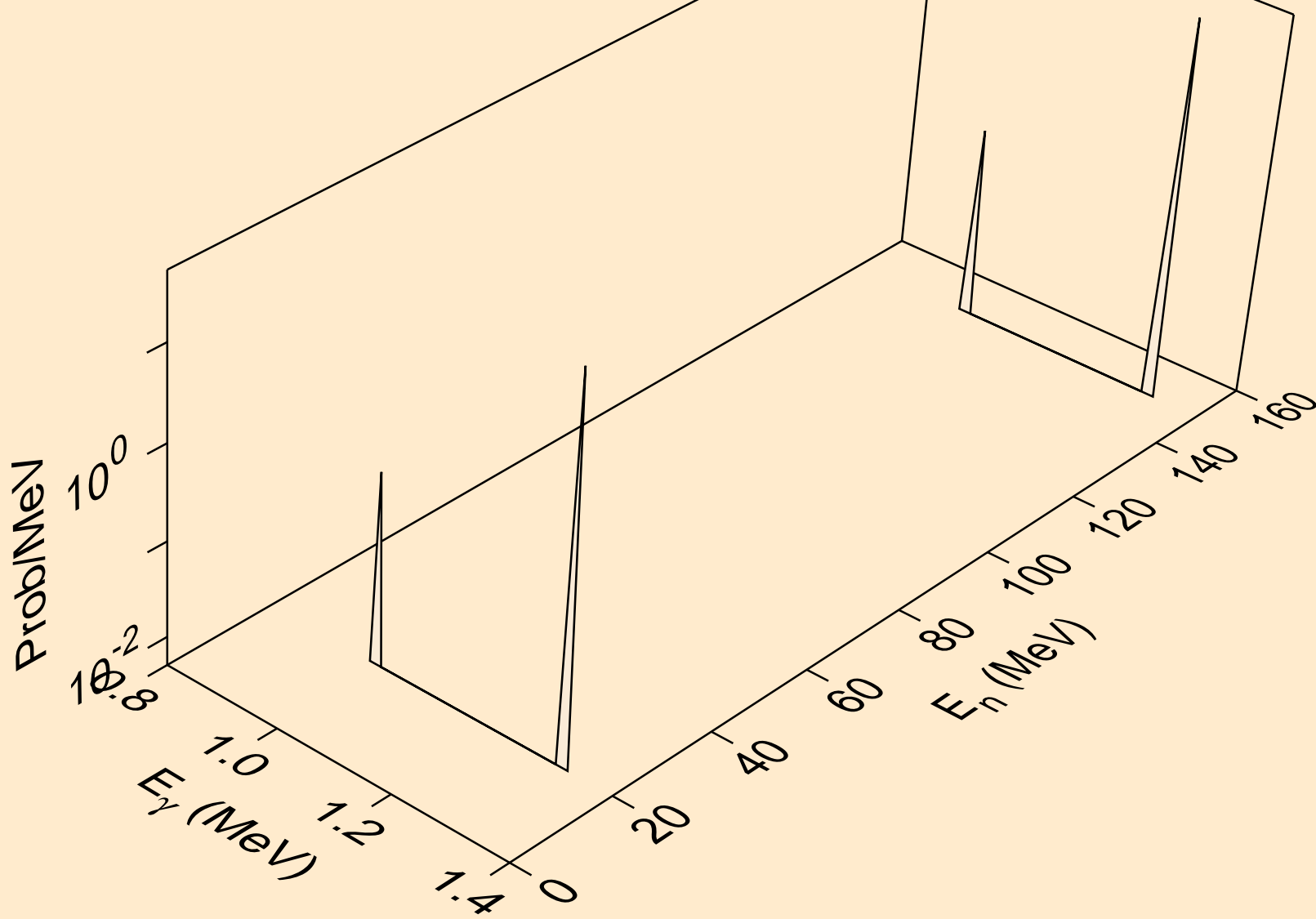

30-ZN-64 FOR FENDL-3.1 FROM FENDL-3.1 WITH NJOY2012.50+
Photon emission for (n,n*5)

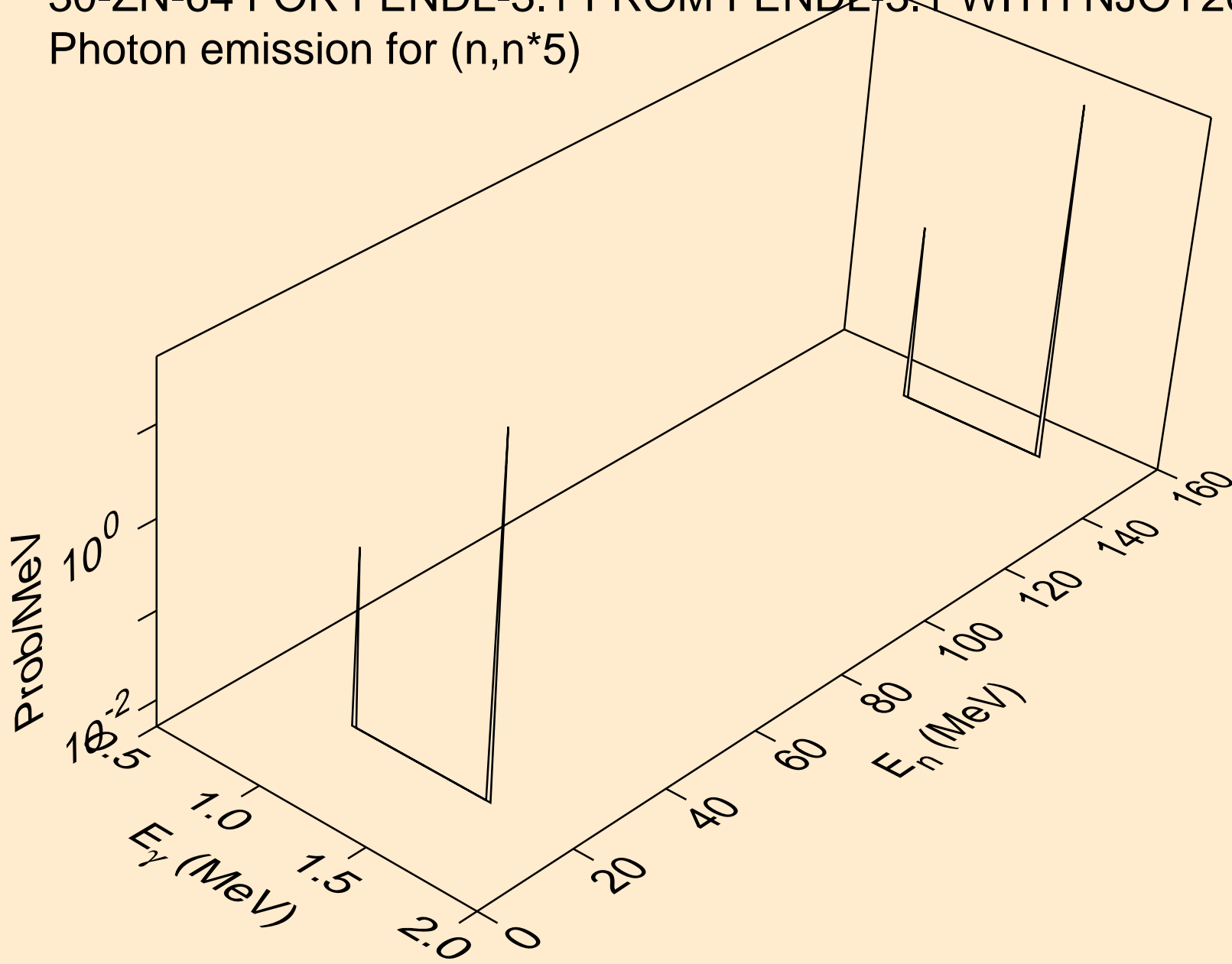

30-ZN-64 FOR FENDL-3.1 FROM FENDL-3.1 WITH NJOY2012.50+
Photon emission for (n,n*6)

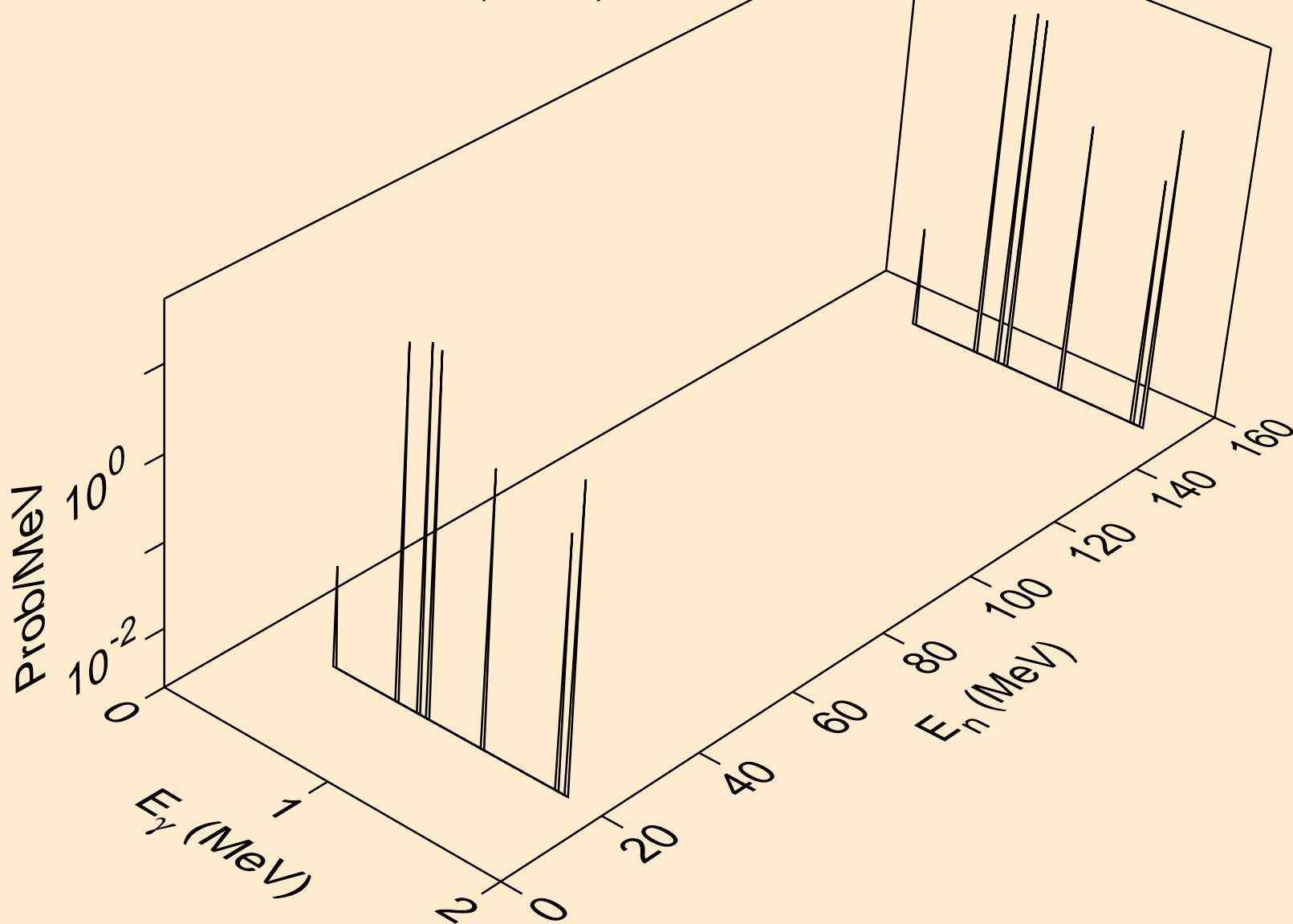

30-ZN-64 FOR FENDL-3.1 FROM FENDL-3.1 WITH NJOY2012.50+
Photon emission for (n,n*7)

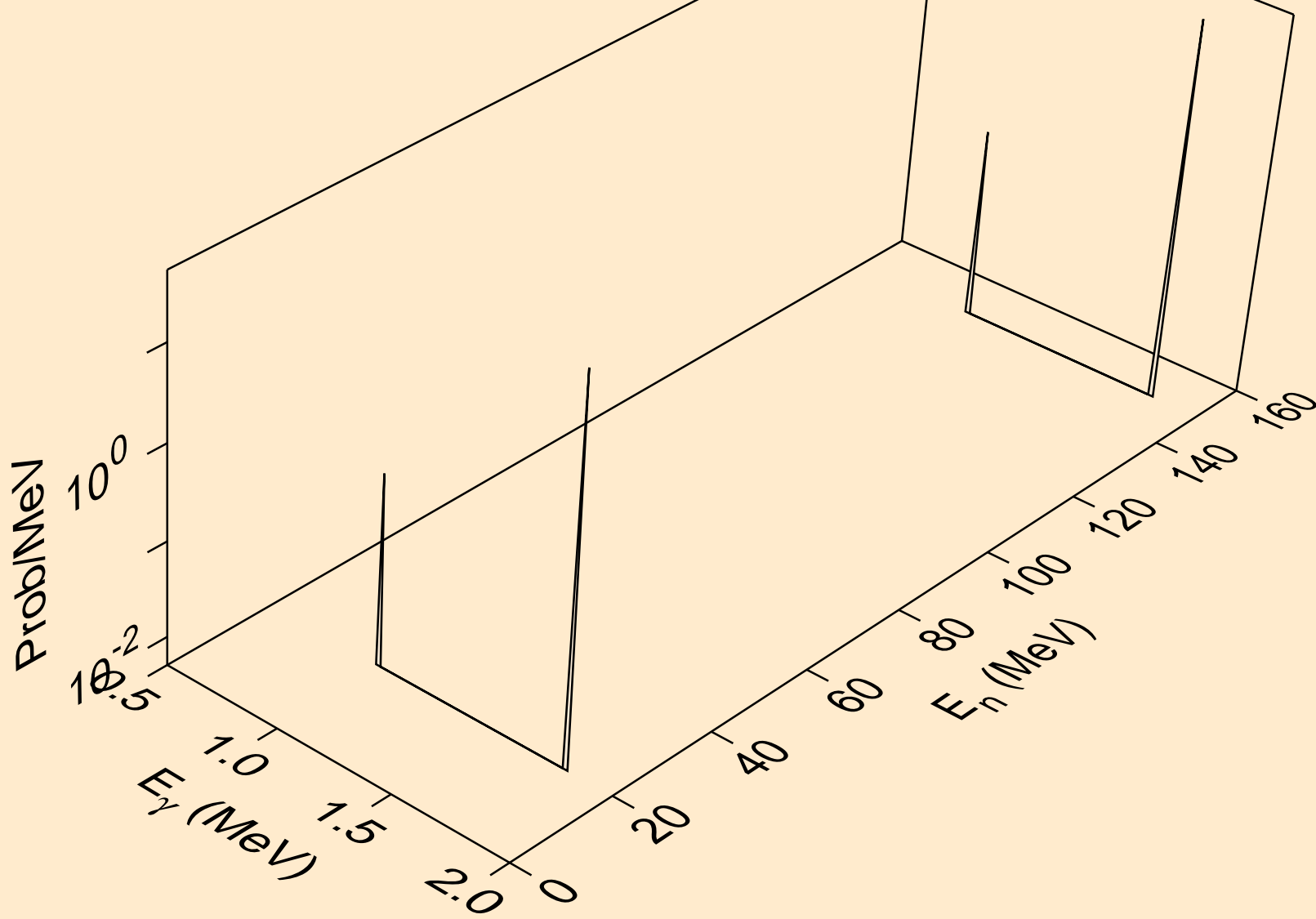

30-ZN-64 FOR FENDL-3.1 FROM FENDL-3.1 WITH NJOY2012.50+
Photon emission for (n,n*8)

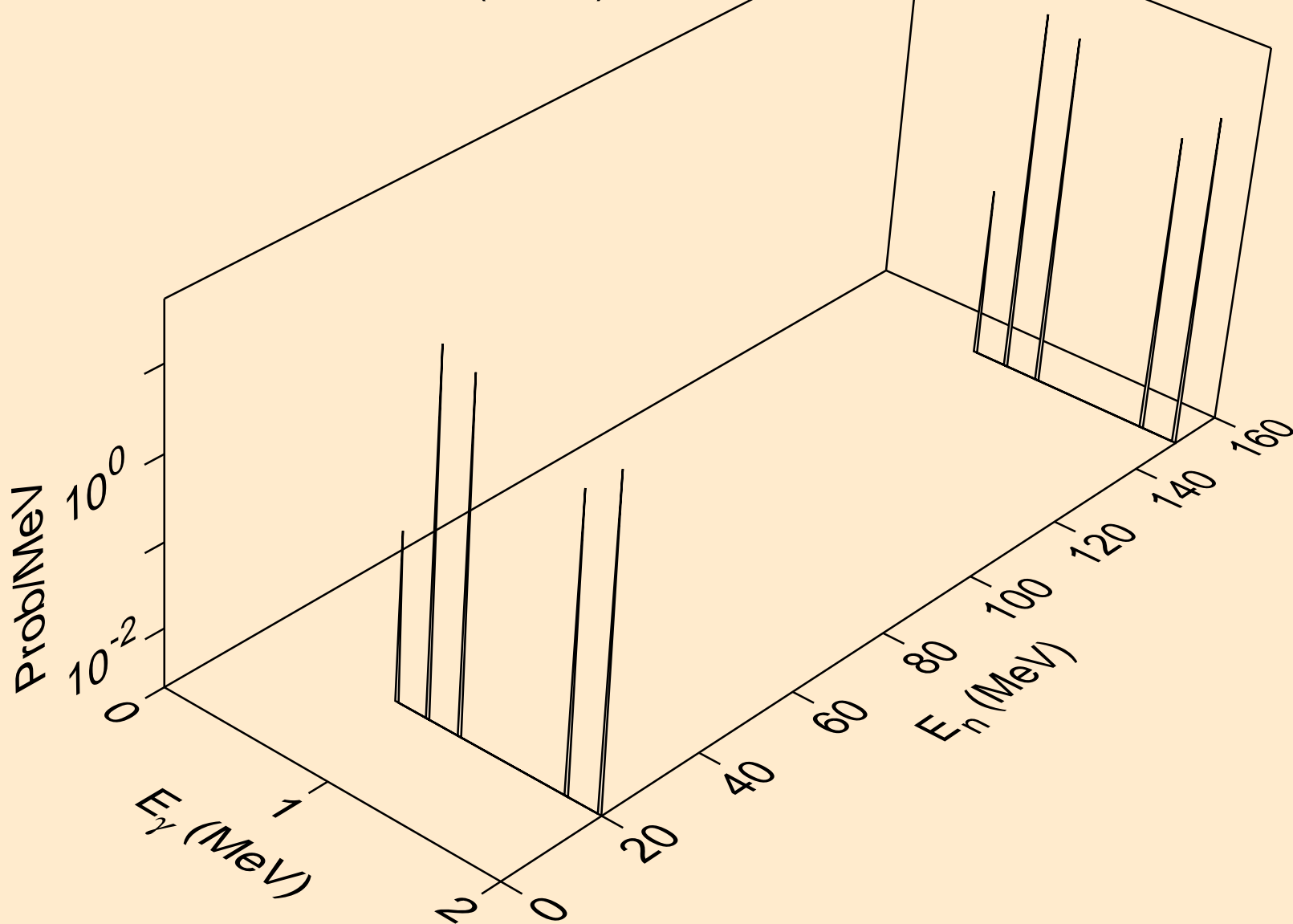

30-ZN-64 FOR FENDL-3.1 FROM FENDL-3.1 WITH NJOY2012.50+
Photon emission for (n,n*9)

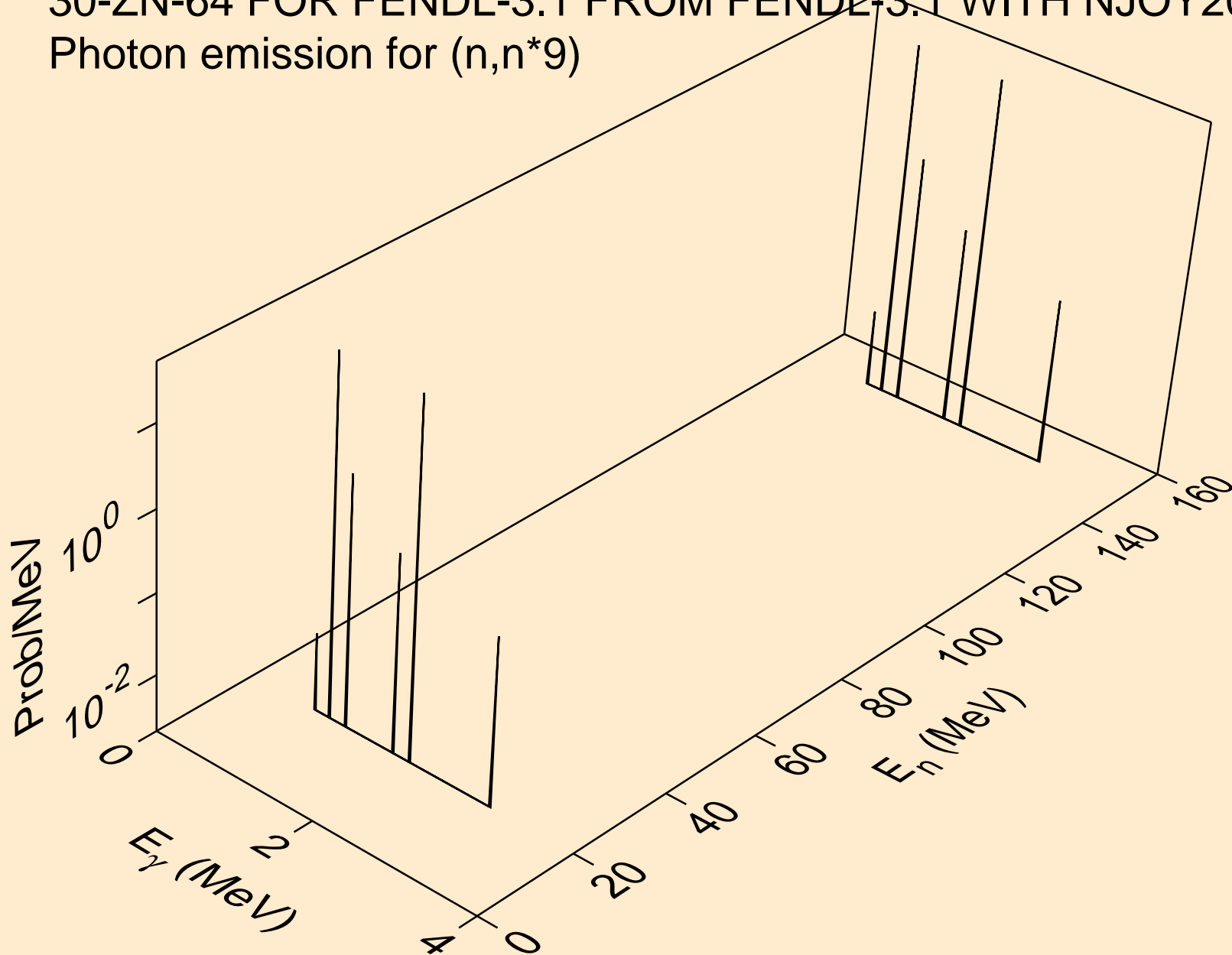

30-ZN-64 FOR FENDL-3.1 FROM FENDL-3.1 WITH NJOY2012.50+
Photon emission for (n,n*10)

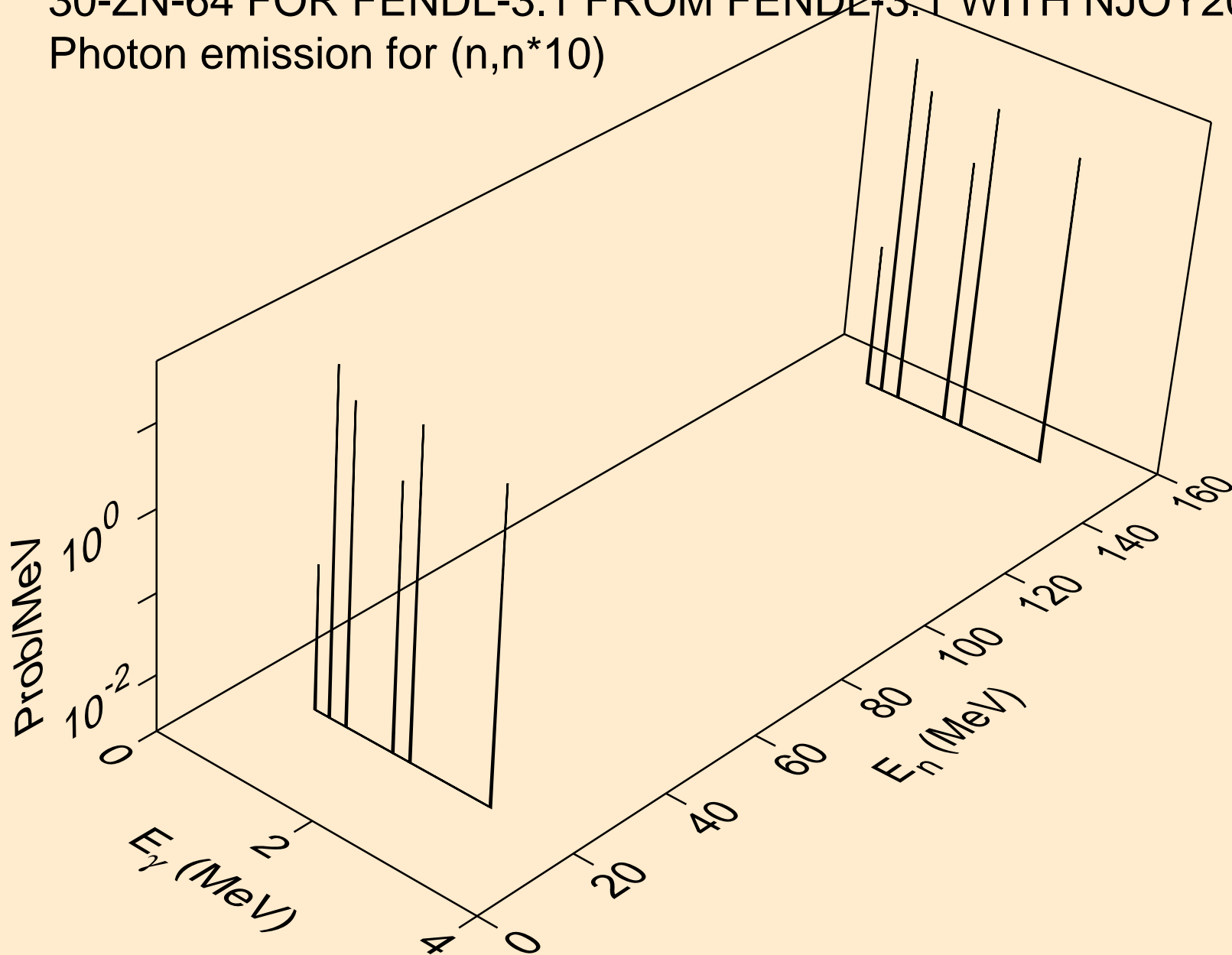

30-ZN-64 FOR FENDL-3.1 FROM FENDL-3.1 WITH NJOY2012.50+
Photon emission for (n,n*11)

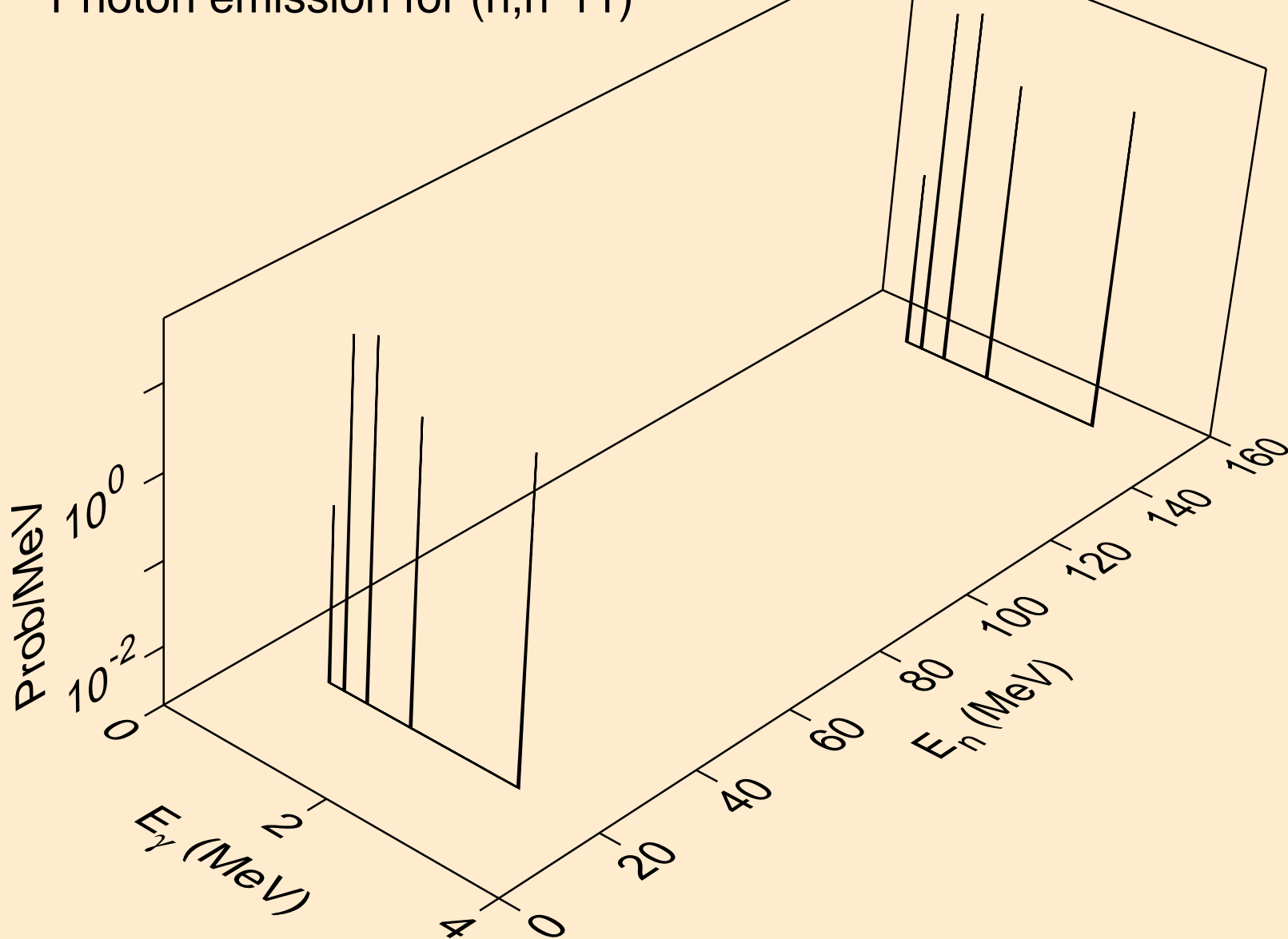

30-ZN-64 FOR FENDL-3.1 FROM FENDL-3.1 WITH NJOY2012.50+
Photon emission for (n,n*12)

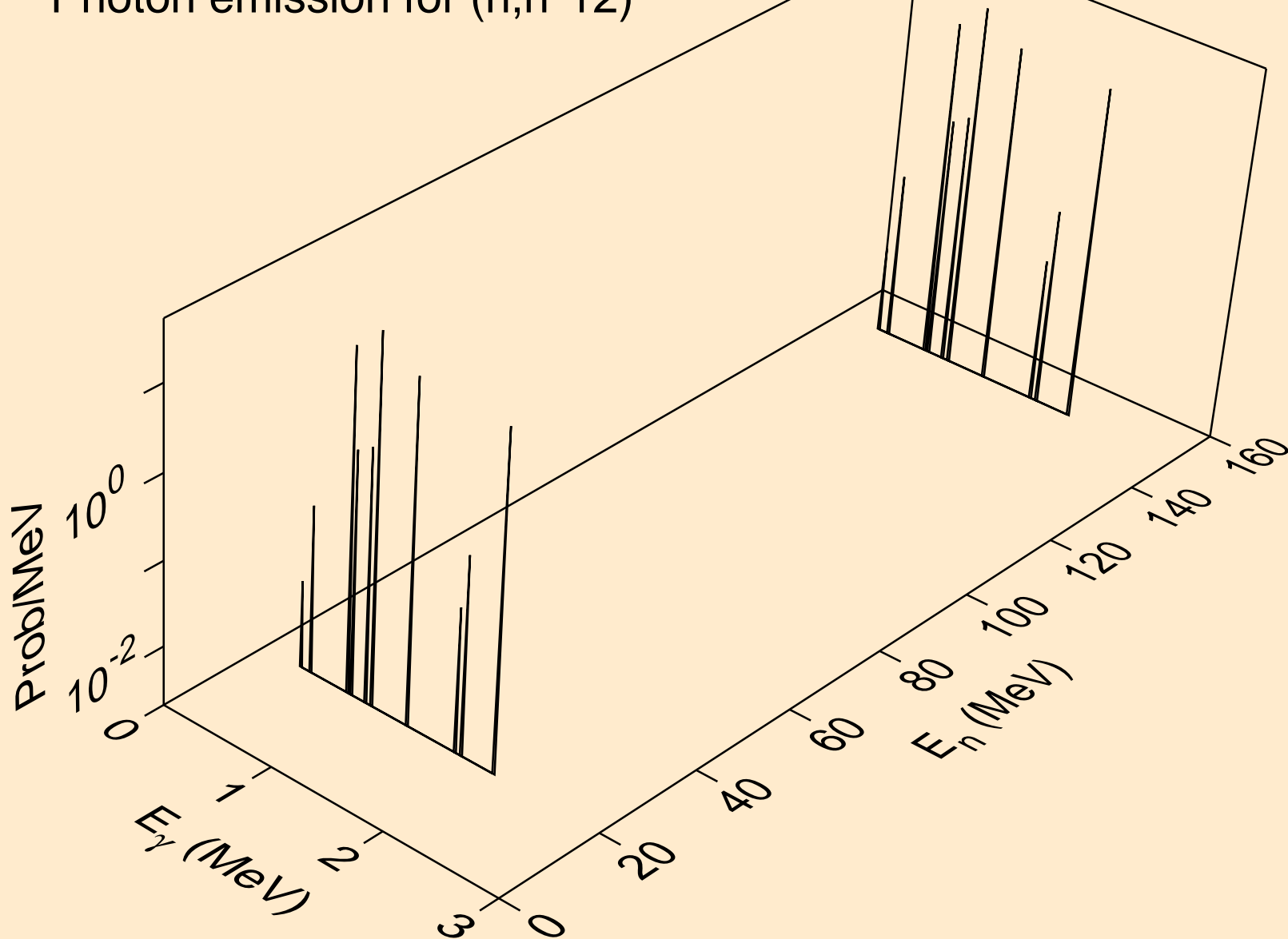

30-ZN-64 FOR FENDL-3.1 FROM FENDL-3.1 WITH NJOY2012.50+
Photon emission for (n,n*13)

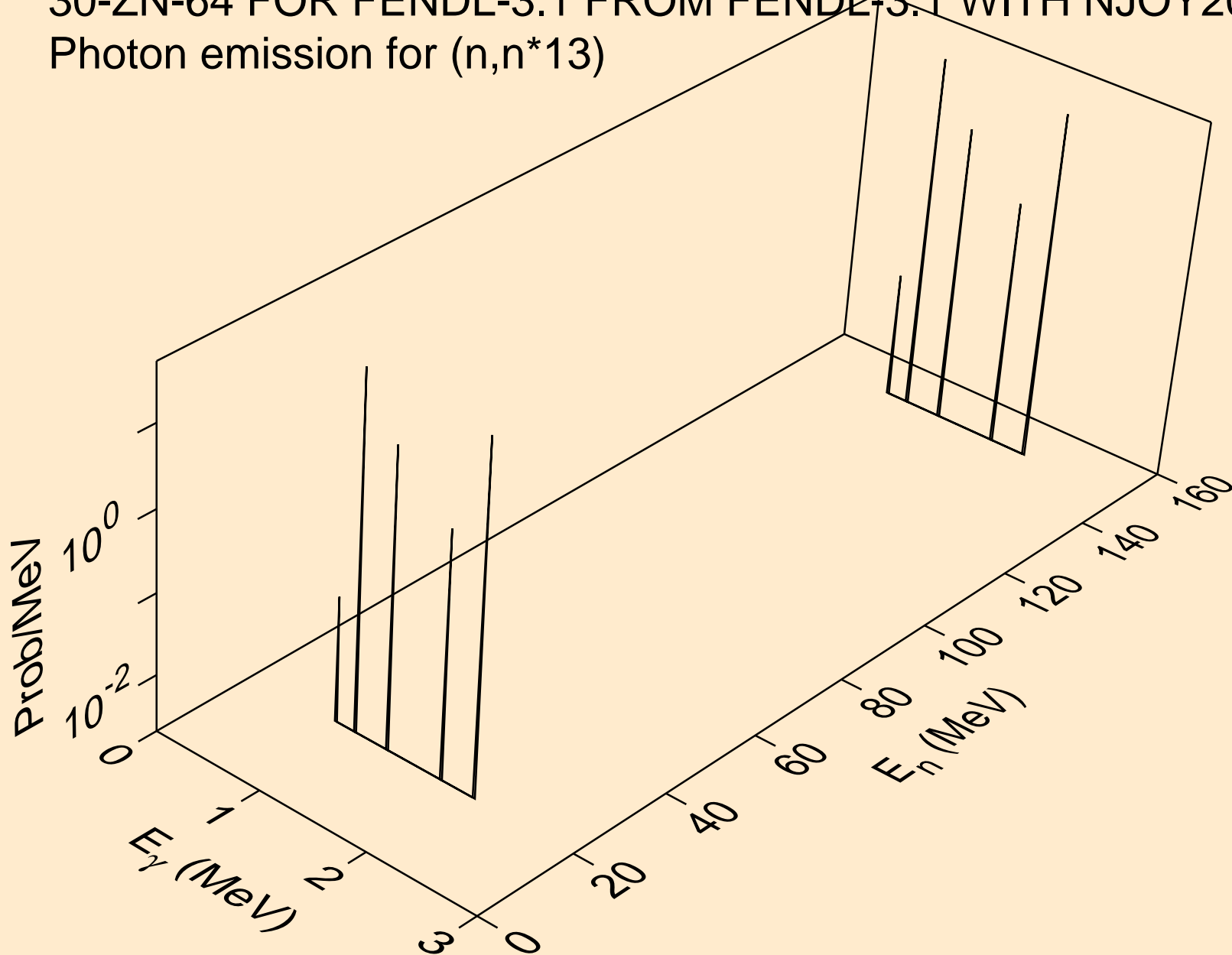

30-ZN-64 FOR FENDL-3.1 FROM FENDL-3.1 WITH NJOY2012.50+
Photon emission for (n,n*14)

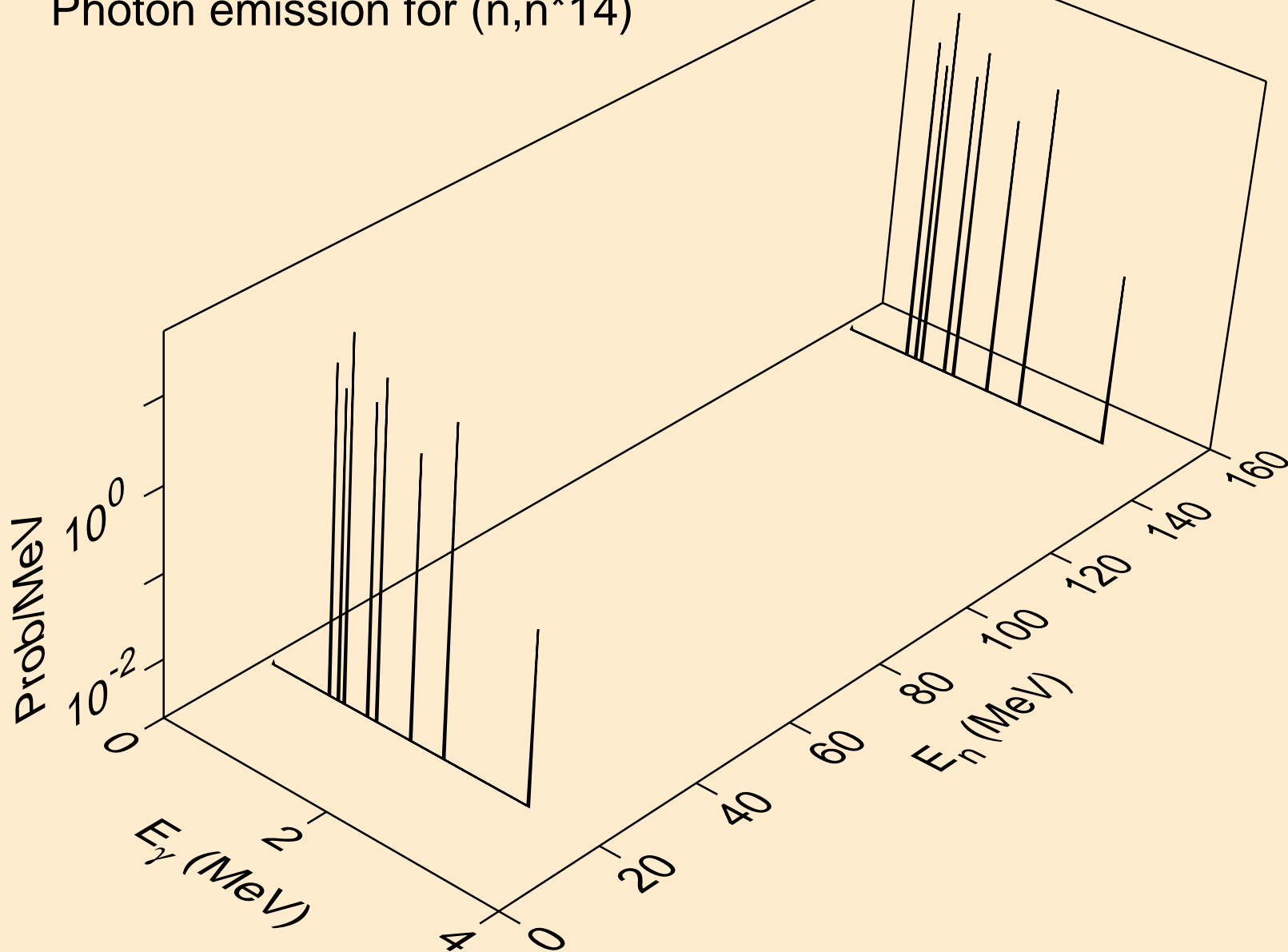

30-ZN-64 FOR FENDL-3.1 FROM FENDL-3.1 WITH NJOY2012.50+
Photon emission for (n,n*15)

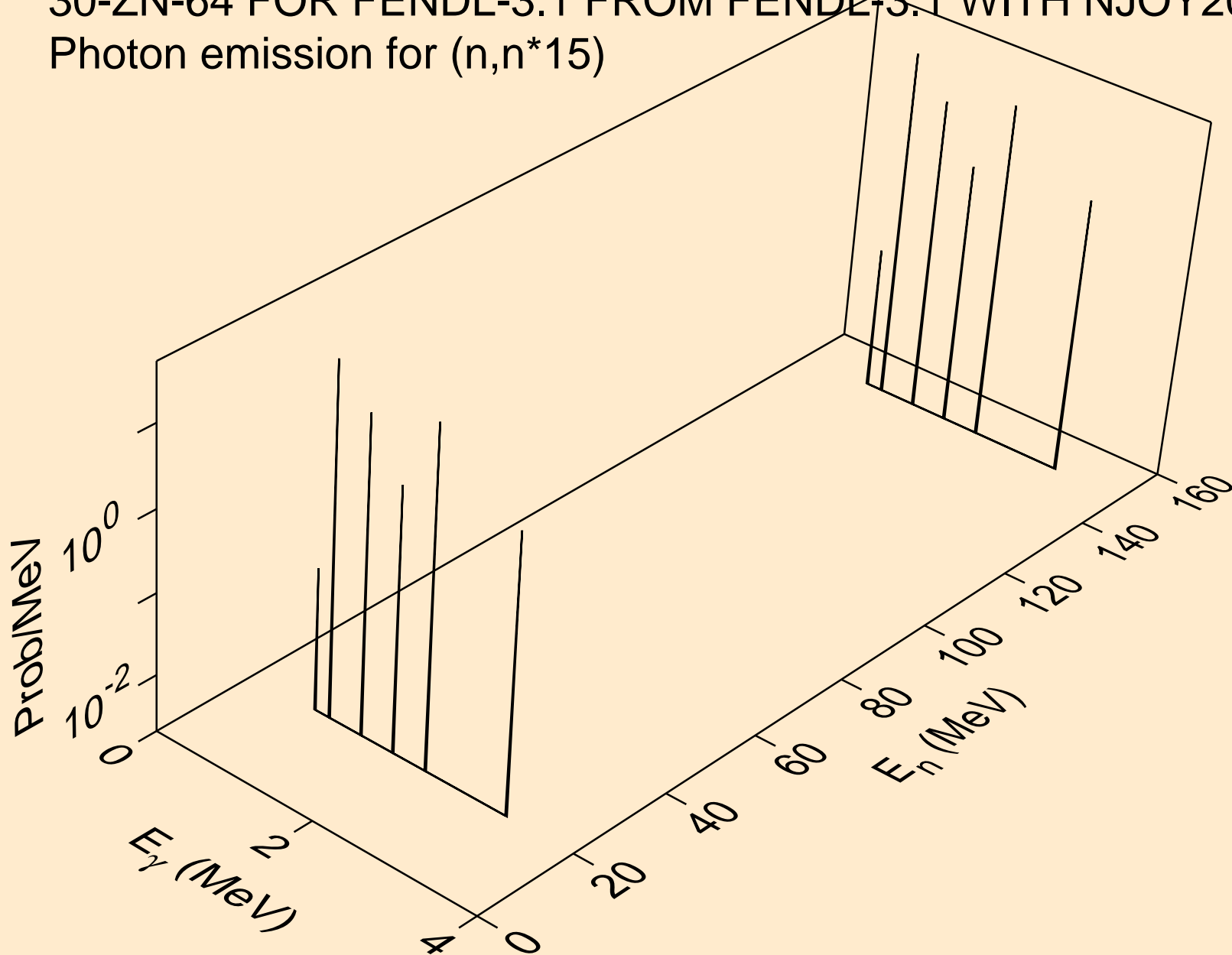

30-ZN-64 FOR FENDL-3.1 FROM FENDL-3.1 WITH NJOY2012.50+
Photon emission for (n,n*16)

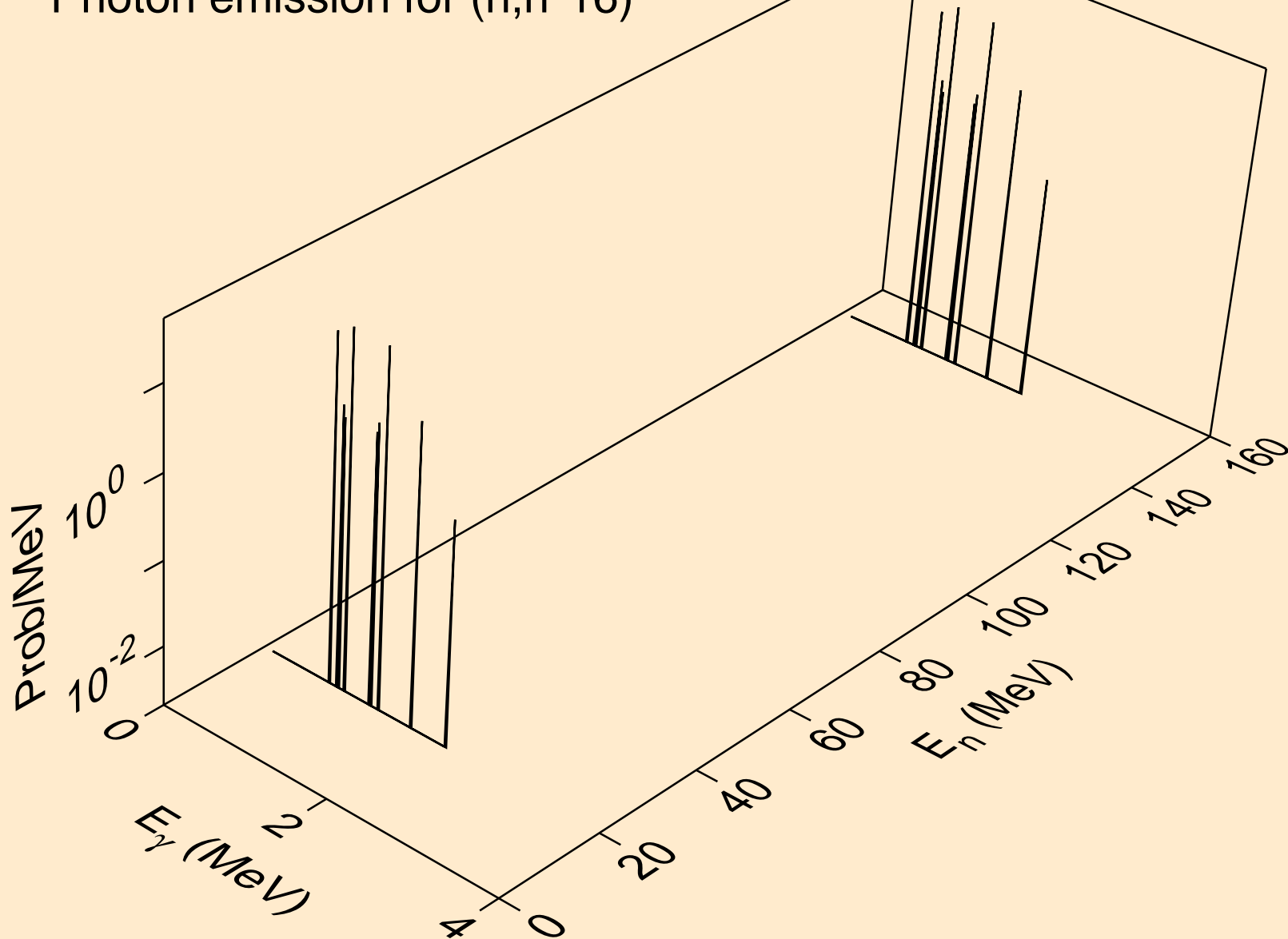

30-ZN-64 FOR FENDL-3.1 FROM FENDL-3.1 WITH NJOY2012.50+
Photon emission for (n,n*17)

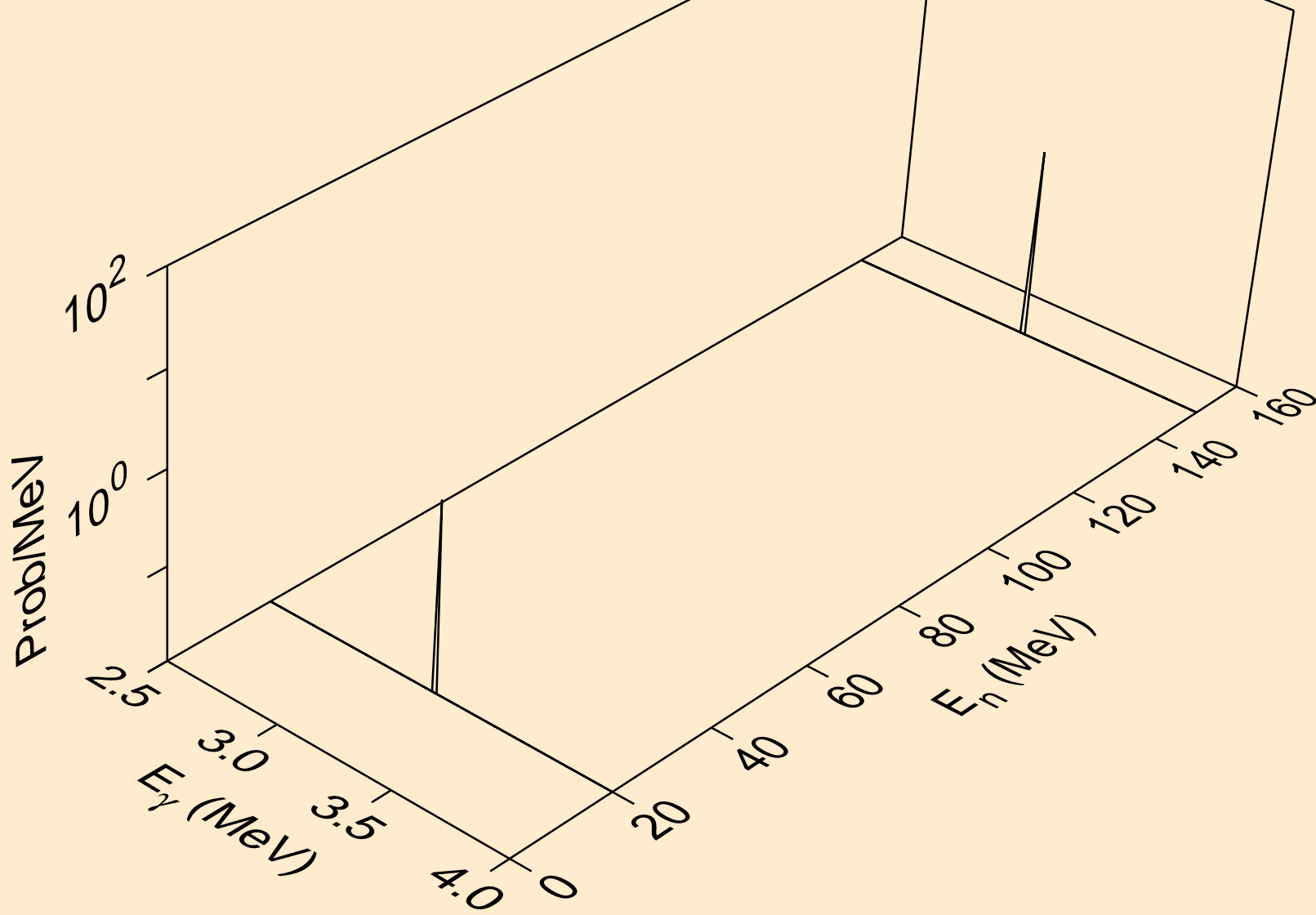

30-ZN-64 FOR FENDL-3.1 FROM FENDL-3.1 WITH NJOY2012.50+
Photon emission for (n,n*18)

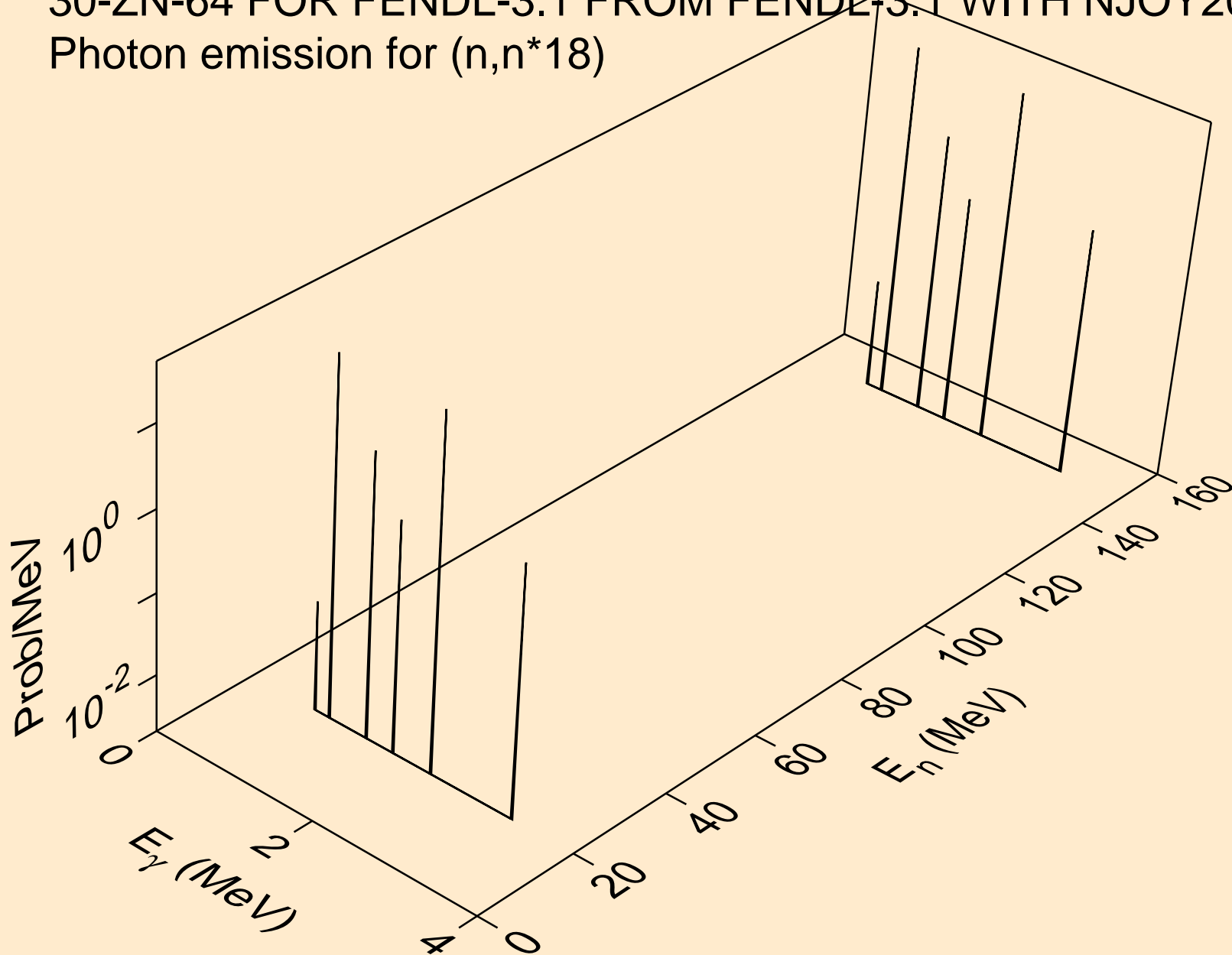

30-ZN-64 FOR FENDL-3.1 FROM FENDL-3.1 WITH NJOY2012.50+
Photon emission for (n,n*19)

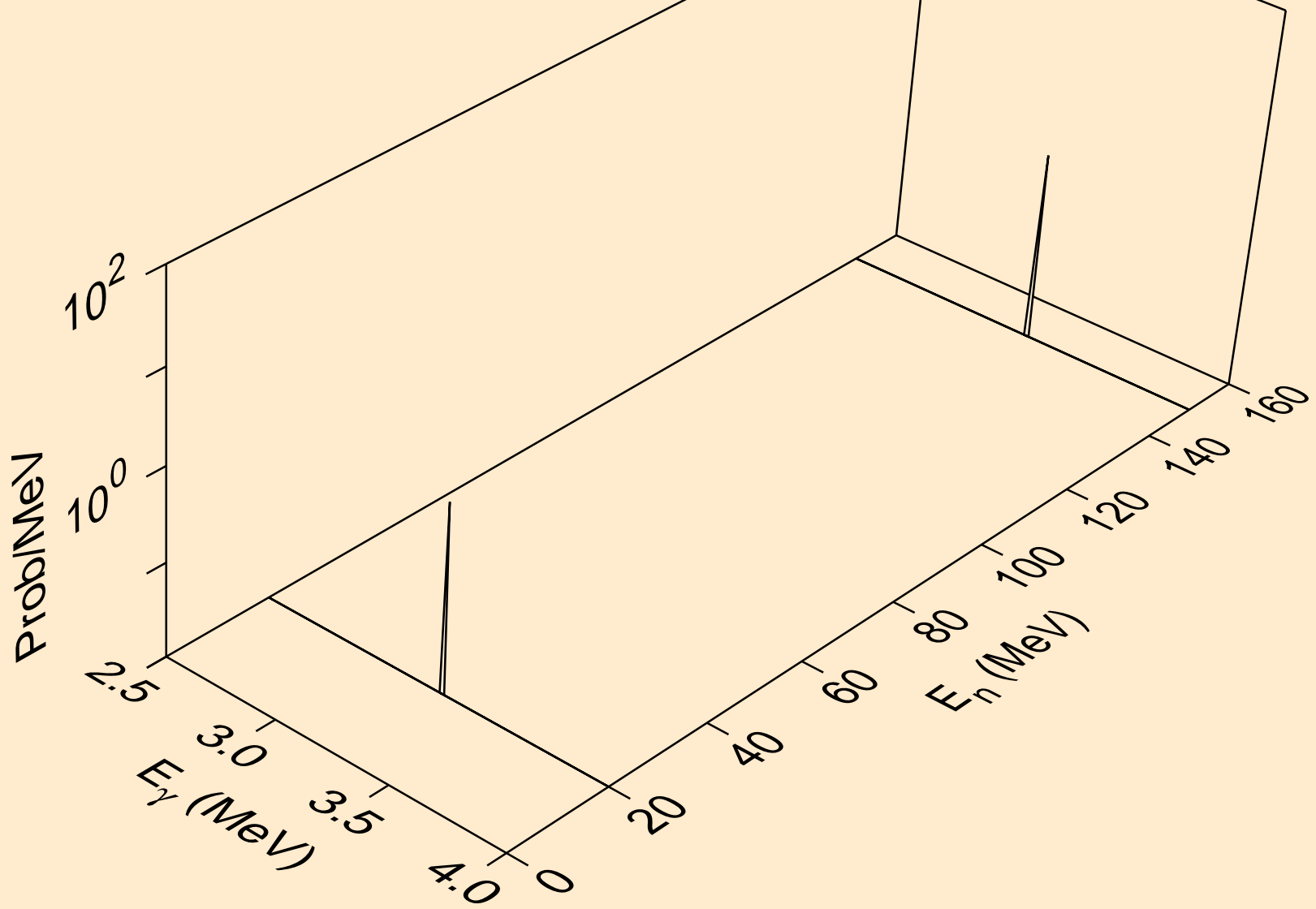

30-ZN-64 FOR FENDL-3.1 FROM FENDL-3.1 WITH NJOY2012.50+
Photon emission for (n,n*20)

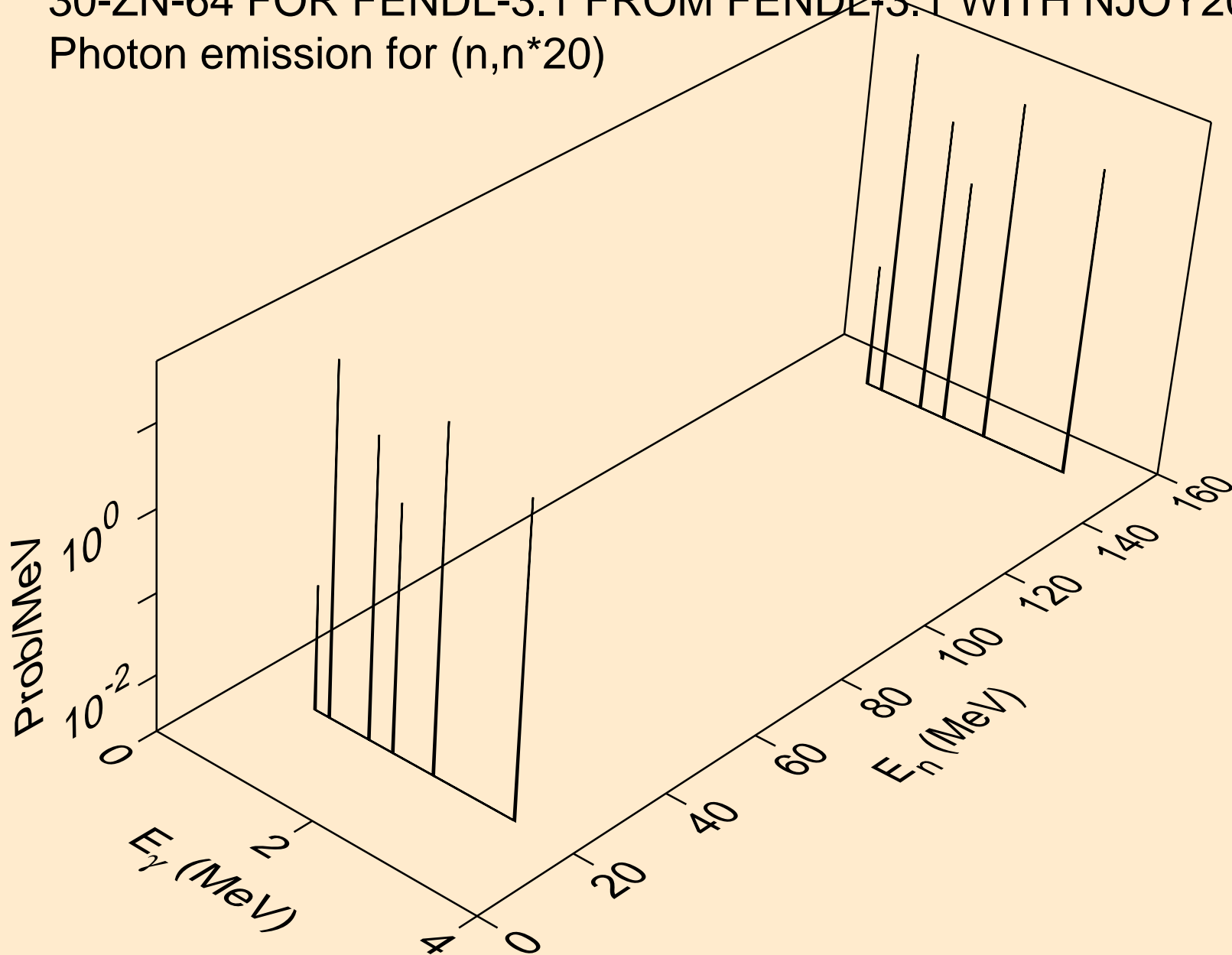

30-ZN-64 FOR FENDL-3.1 FROM FENDL-3.1 WITH NJOY2012.50+
Photon emission for (n,n*21)

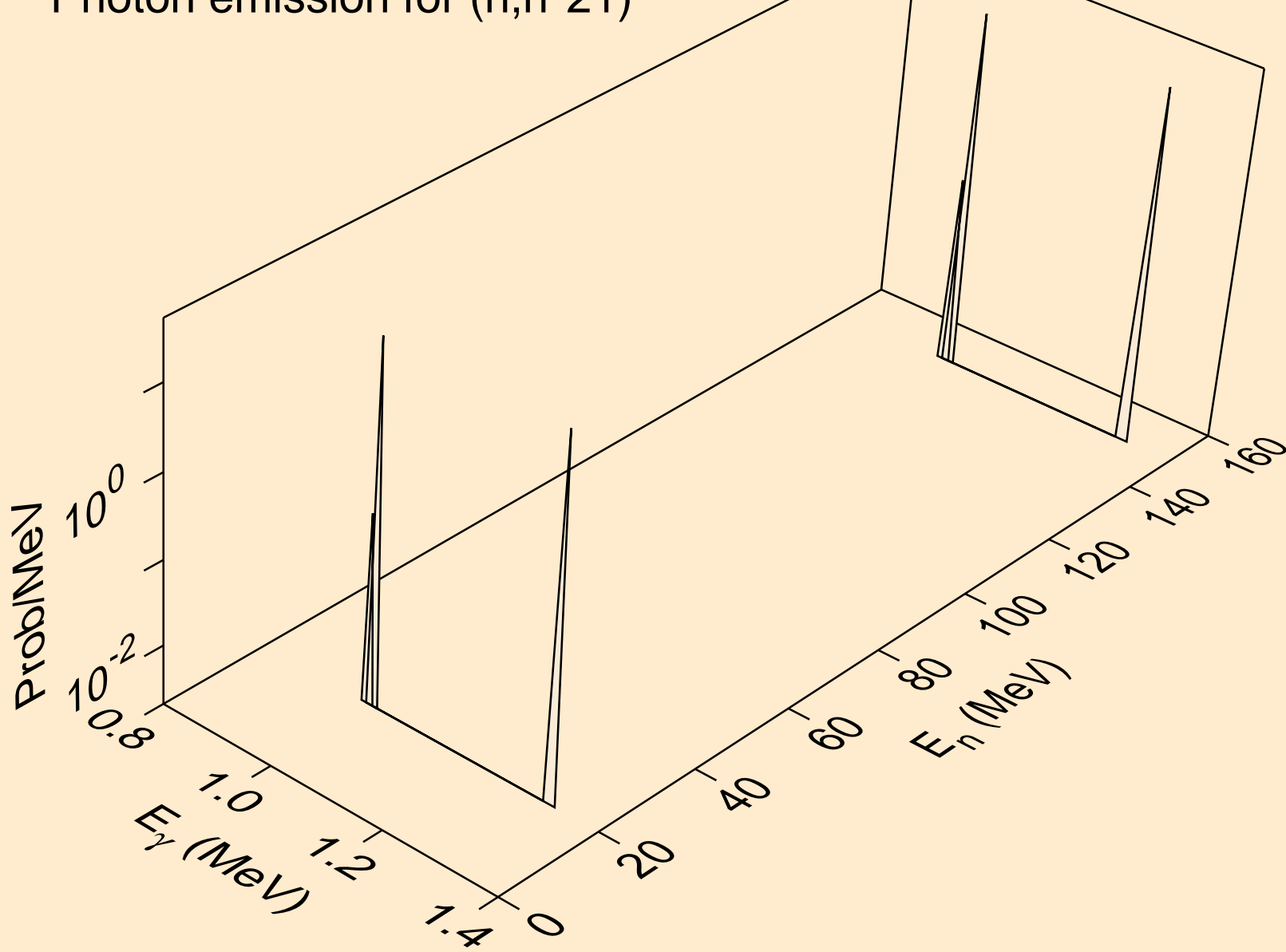

30-ZN-64 FOR FENDL-3.1 FROM FENDL-3.1 WITH NJOY2012.50+
Photon emission for (n,n*22)

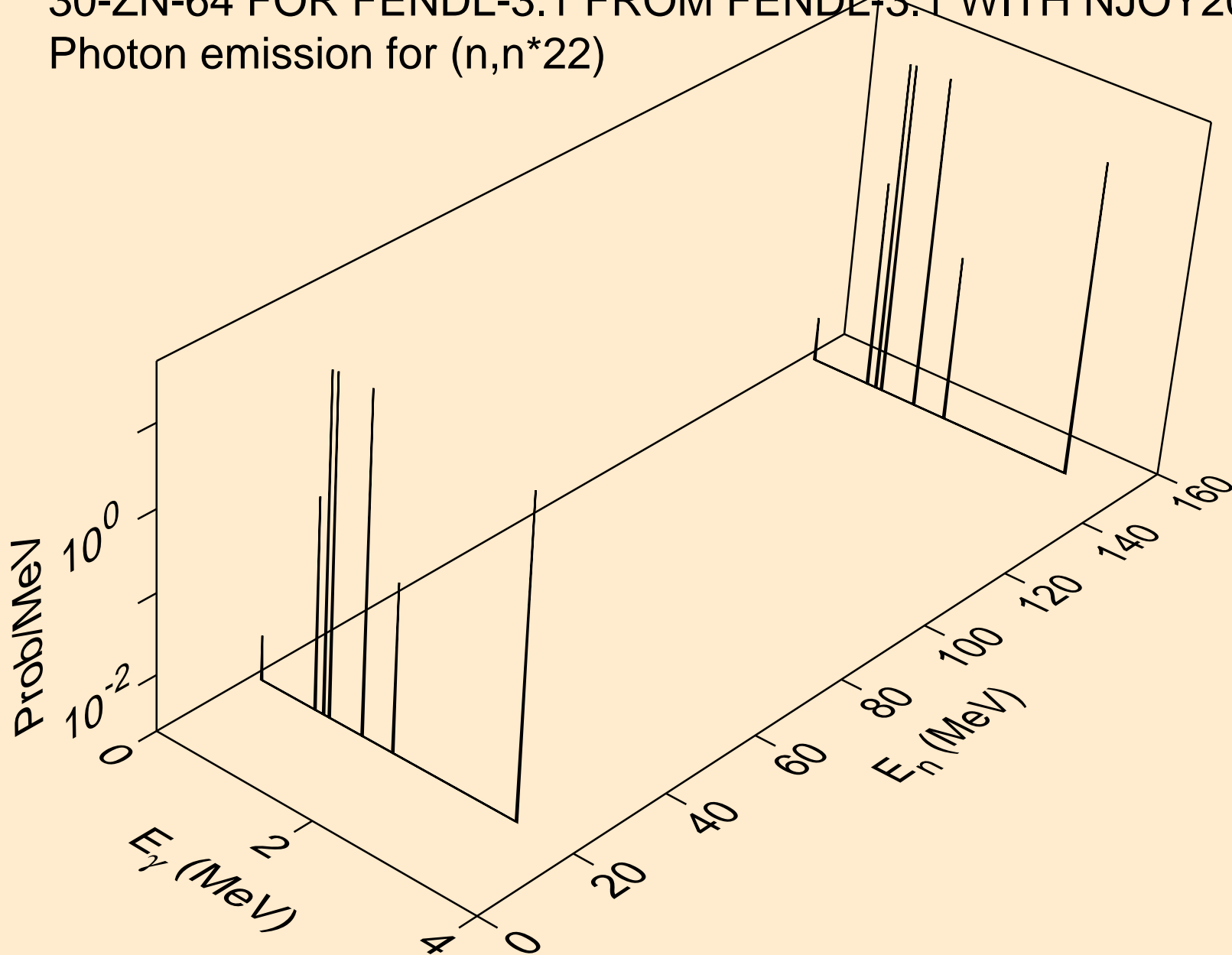

30-ZN-64 FOR FENDL-3.1 FROM FENDL-3.1 WITH NJOY2012.50+
Photon emission for (n,n*23)

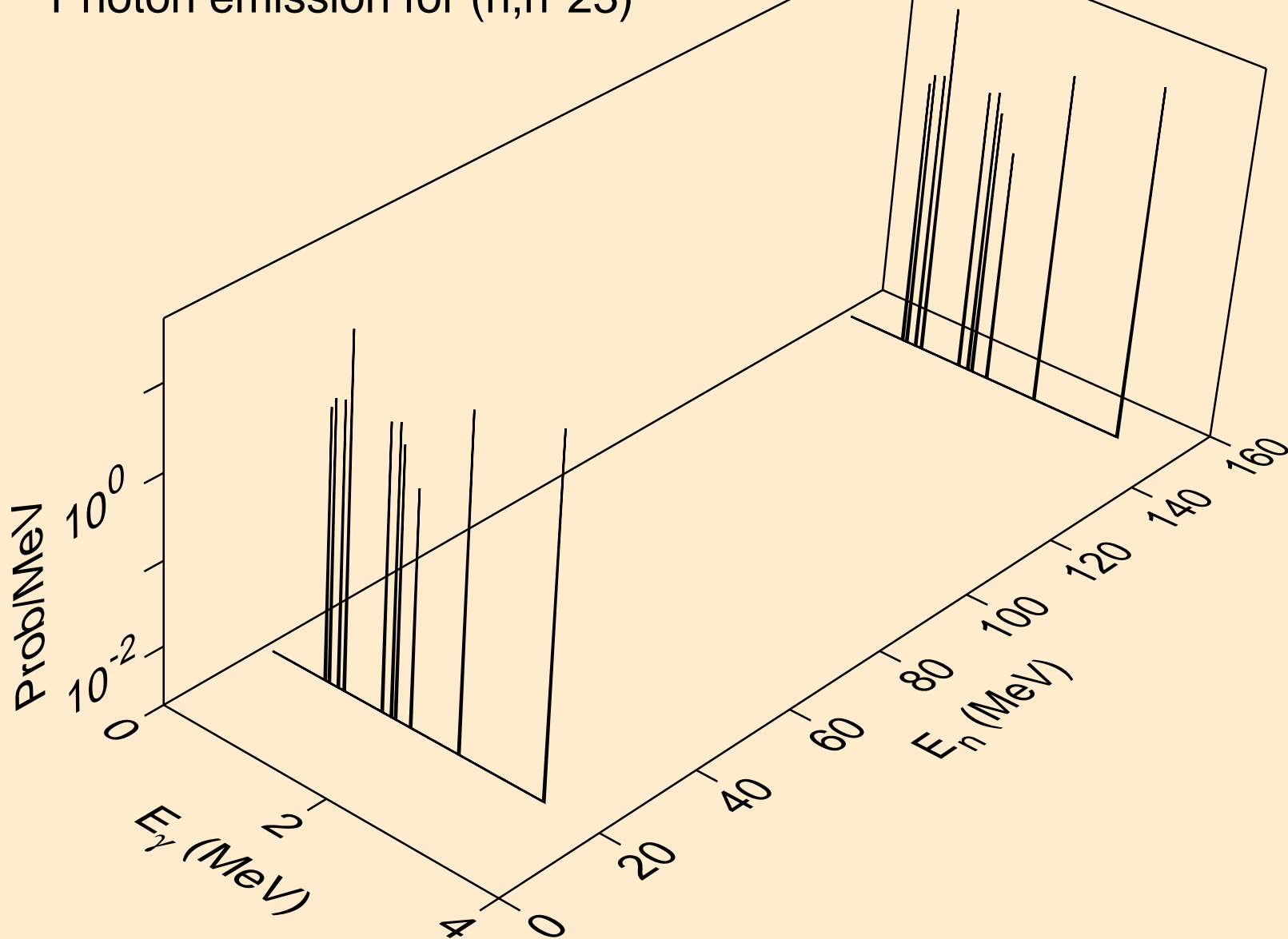

30-ZN-64 FOR FENDL-3.1 FROM FENDL-3.1 WITH NJOY2012.50+
Photon emission for (n,n*24)

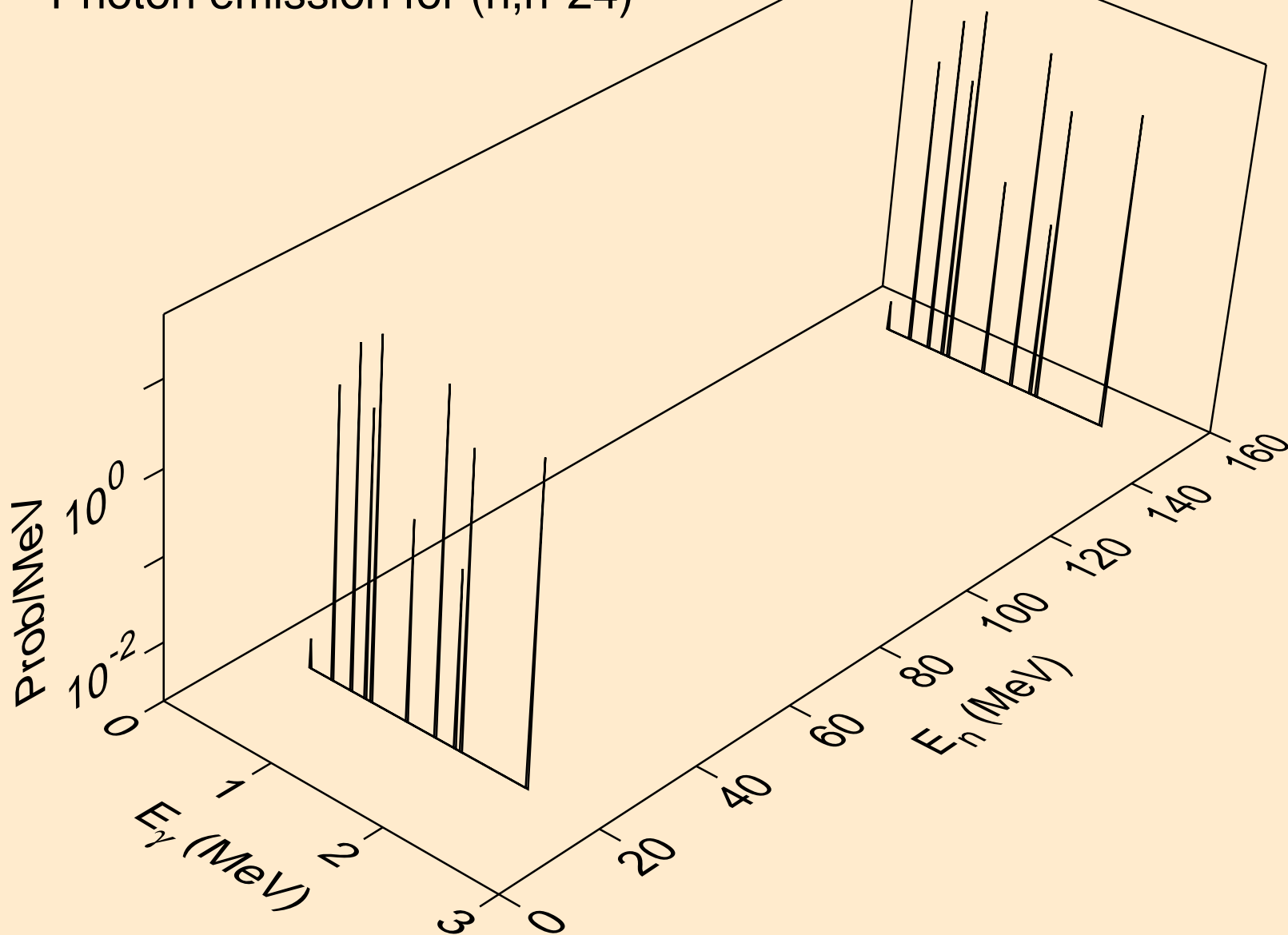

30-ZN-64 FOR FENDL-3.1 FROM FENDL-3.1 WITH NJOY2012.50+
Photon emission for (n,n*25)

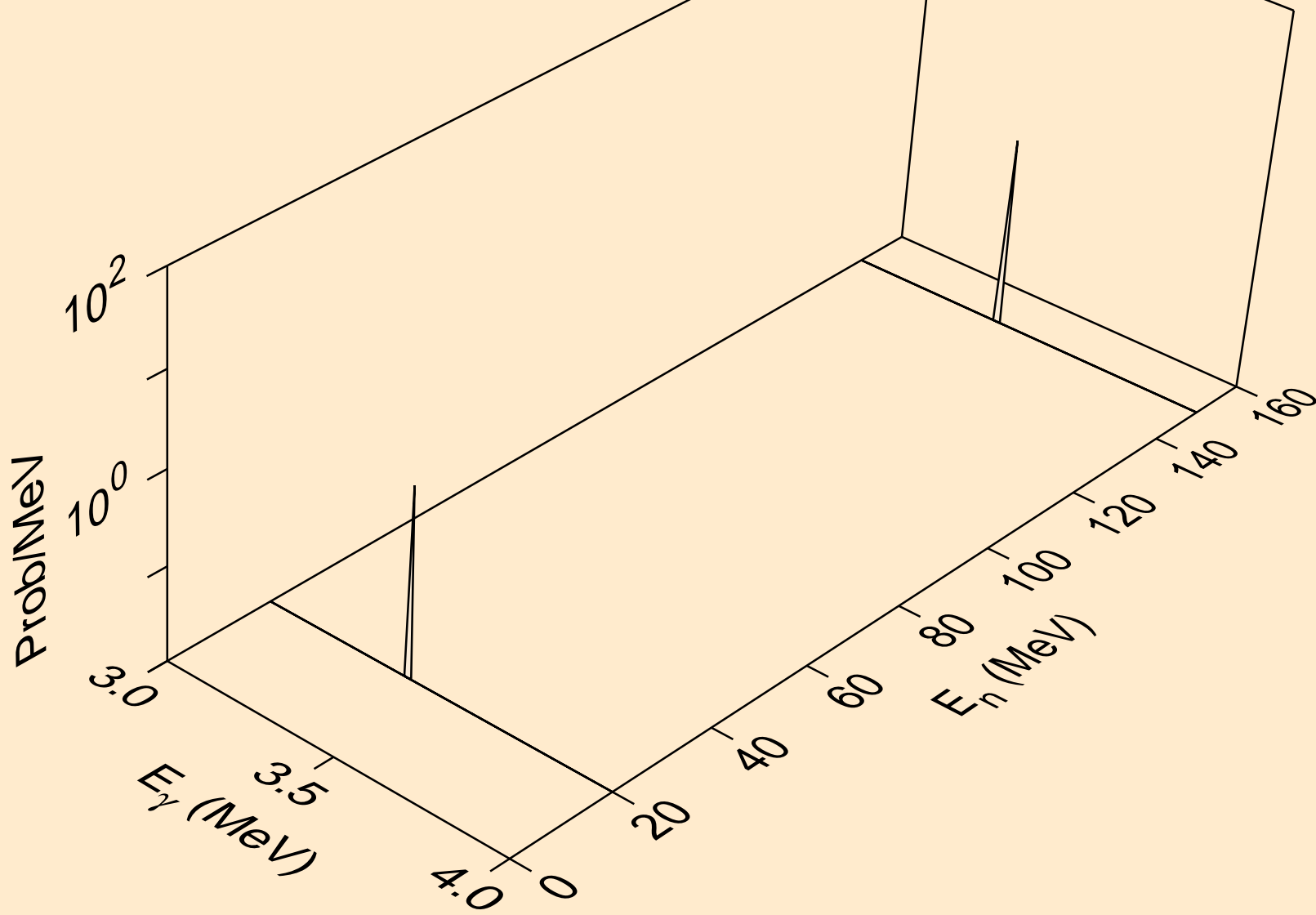

30-ZN-64 FOR FENDL-3.1 FROM FENDL-3.1 WITH NJOY2012.50+
Photon emission for (n,n*26)

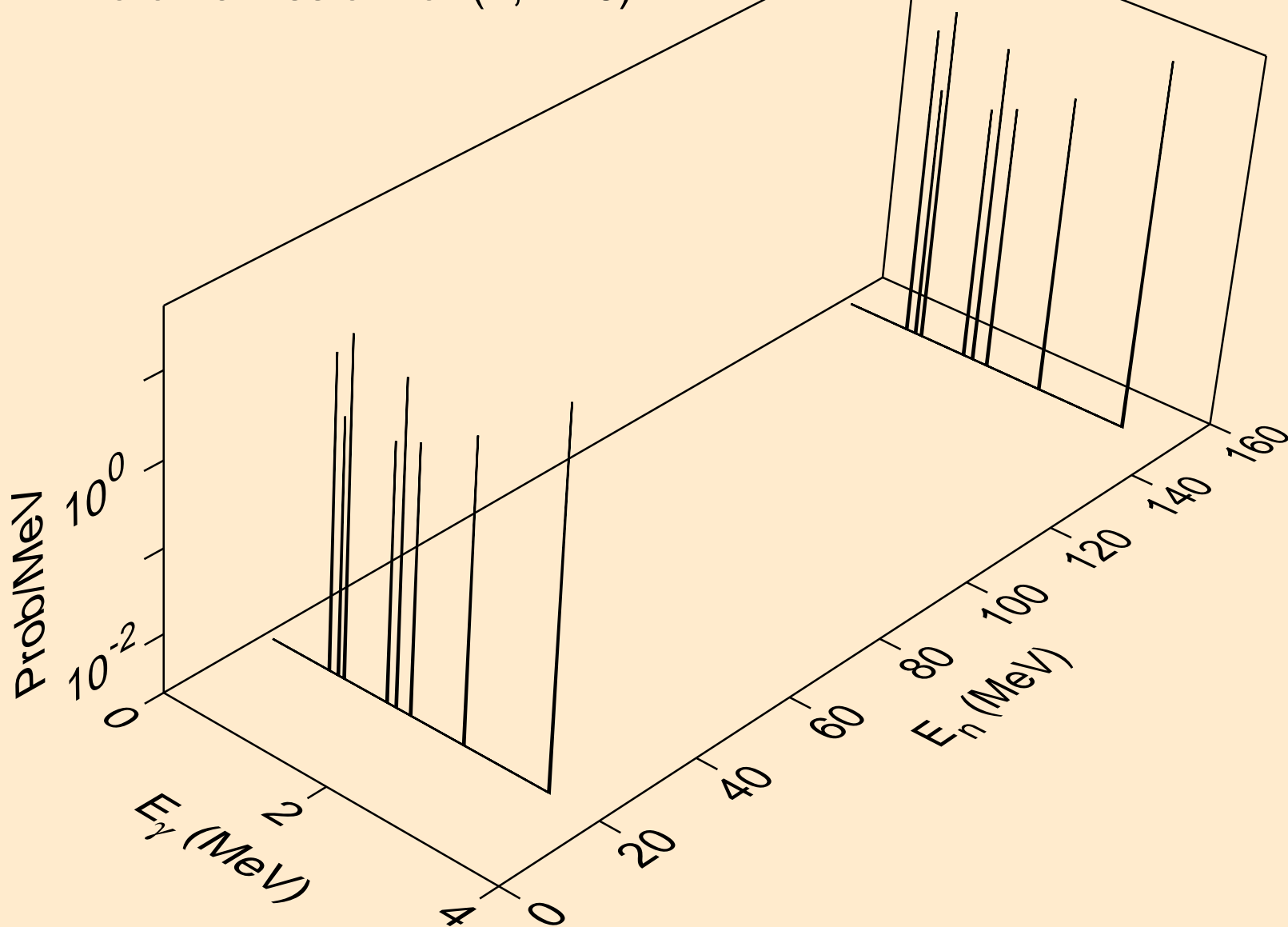

30-ZN-64 FOR FENDL-3.1 FROM FENDL-3.1 WITH NJOY2012.50+
Photon emission for (n,n*27)

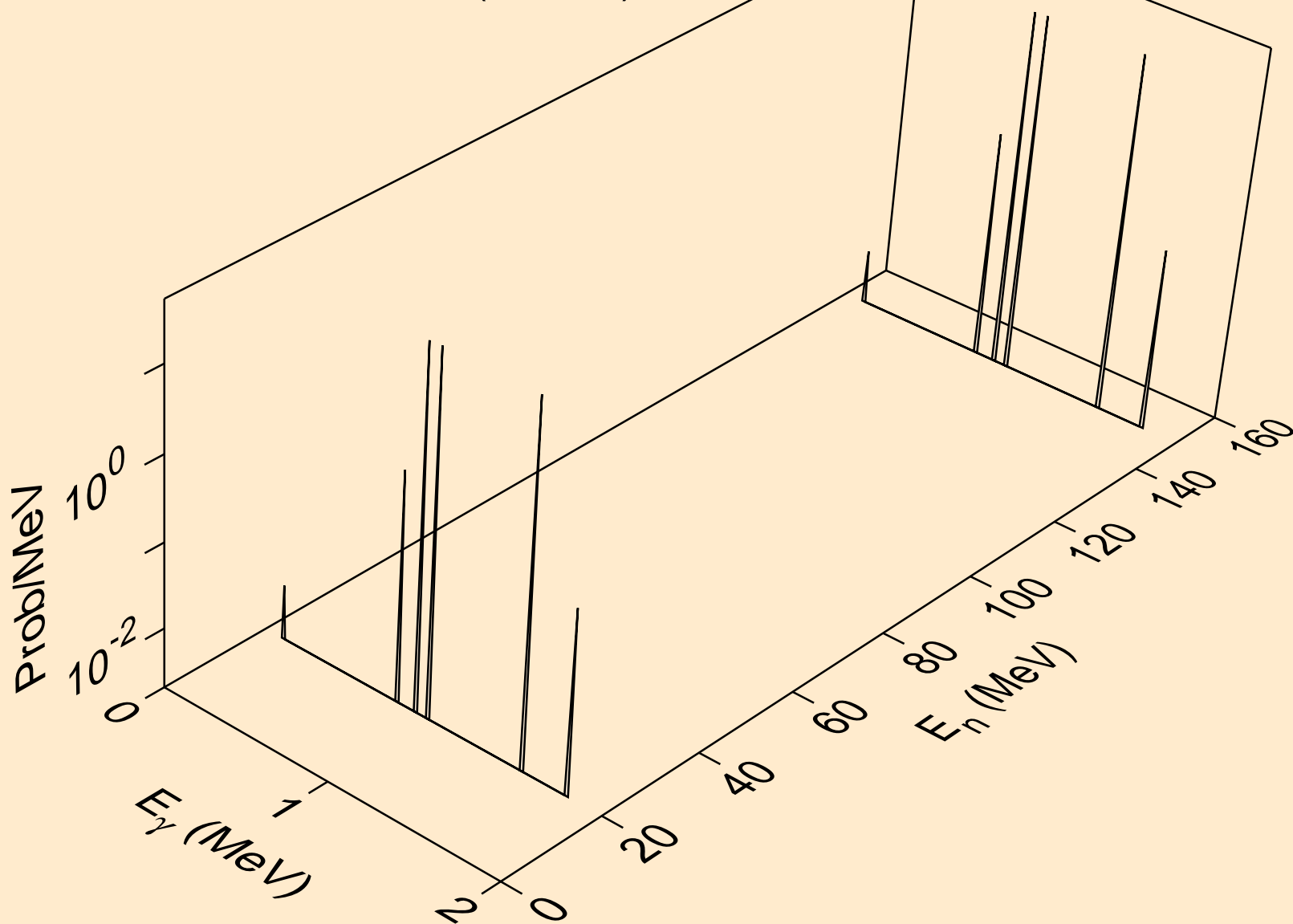

30-ZN-64 FOR FENDL-3.1 FROM FENDL-3.1 WITH NJOY2012.50+
Photon emission for (n,n*28)

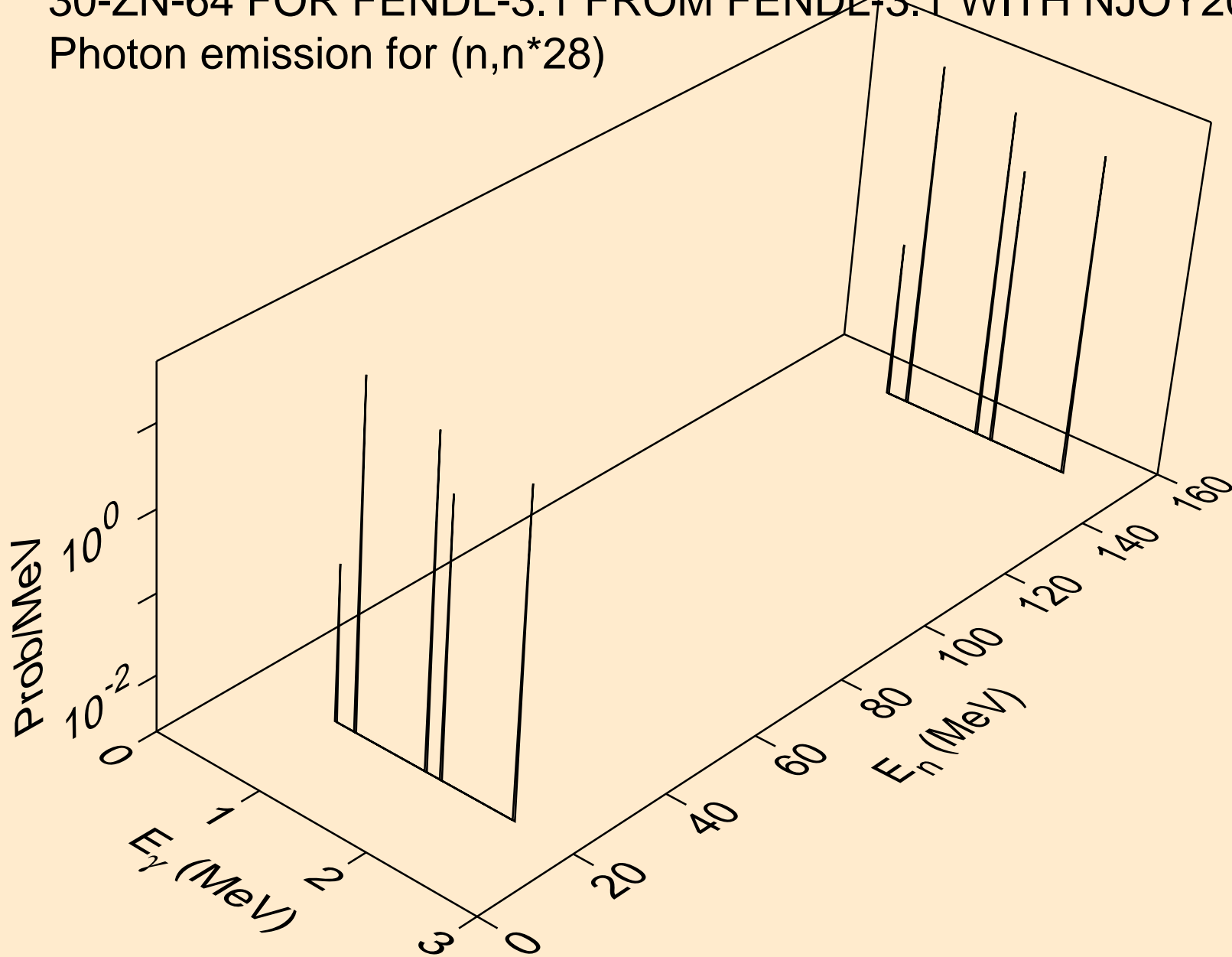

30-ZN-64 FOR FENDL-3.1 FROM FENDL-3.1 WITH NJOY2012.50+
Photon emission for (n,n*29)

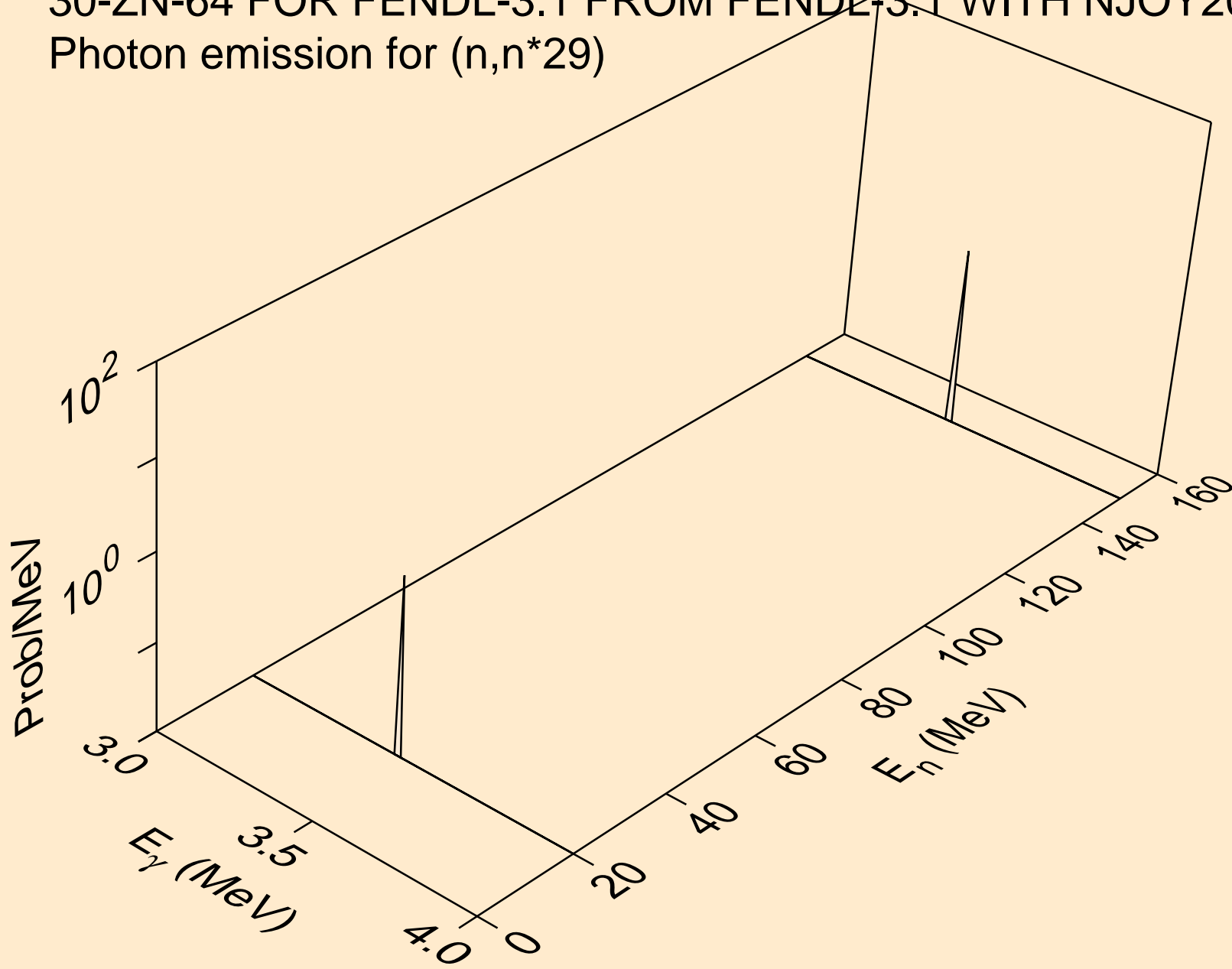

30-ZN-64 FOR FENDL-3.1 FROM FENDL-3.1 WITH NJOY2012.50+
Photon emission for (n,n*30)

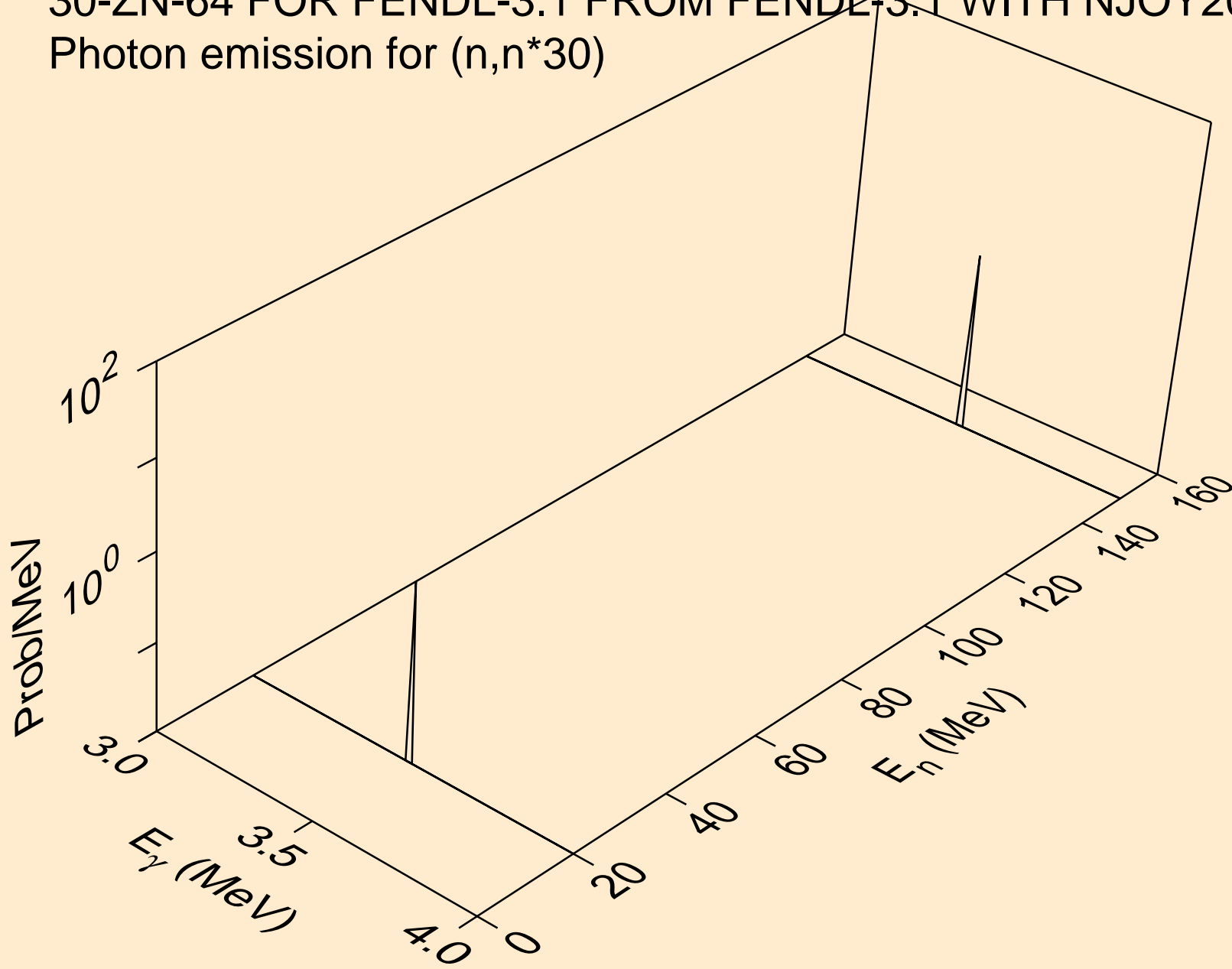

30-ZN-64 FOR FENDL-3.1 FROM FENDL-3.1 WITH NJOY2012.50+
Photon emission for (n,n*31)

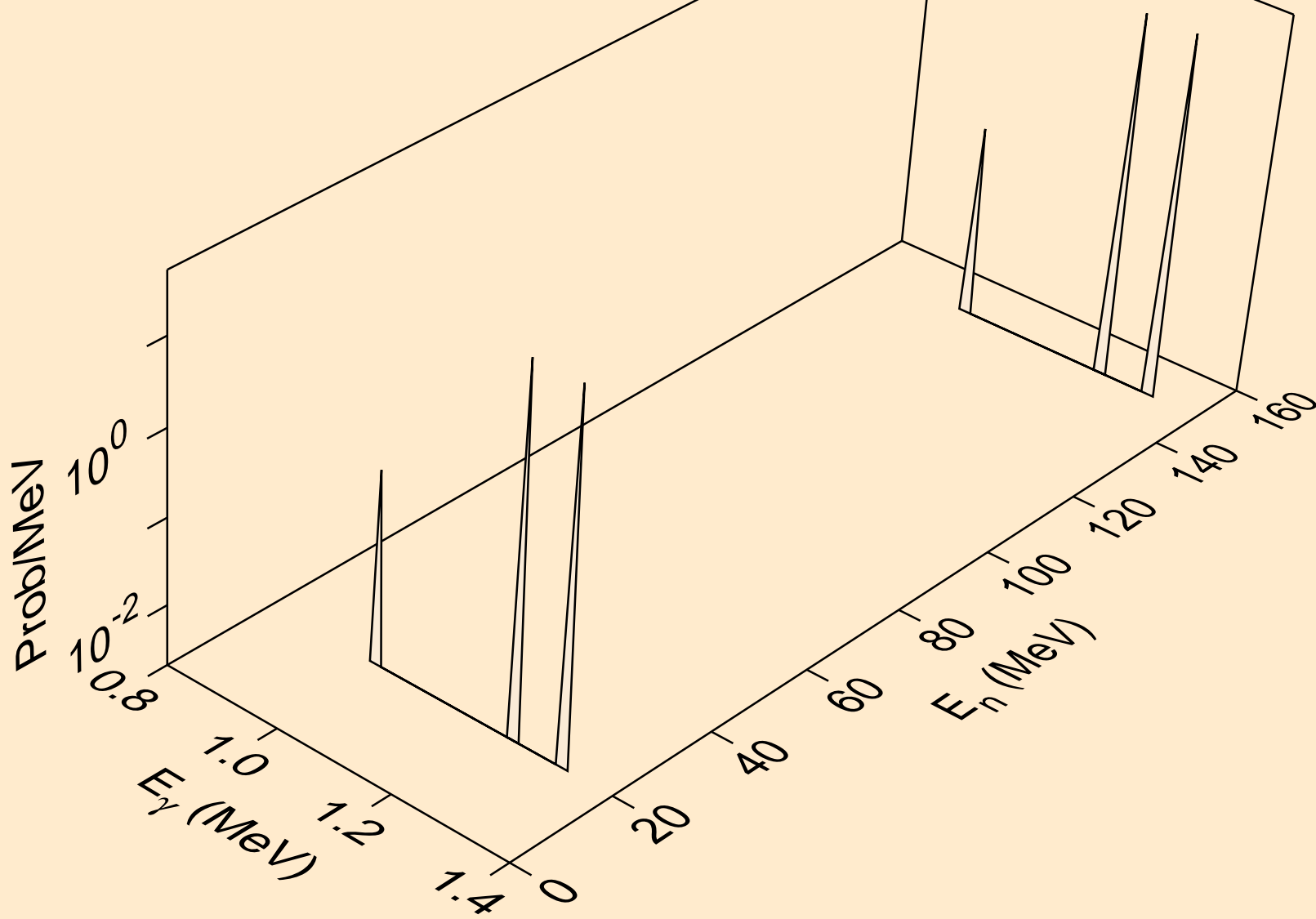

30-ZN-64 FOR FENDL-3.1 FROM FENDL-3.1 WITH NJOY2012.50+
Photon emission for (n,n*32)

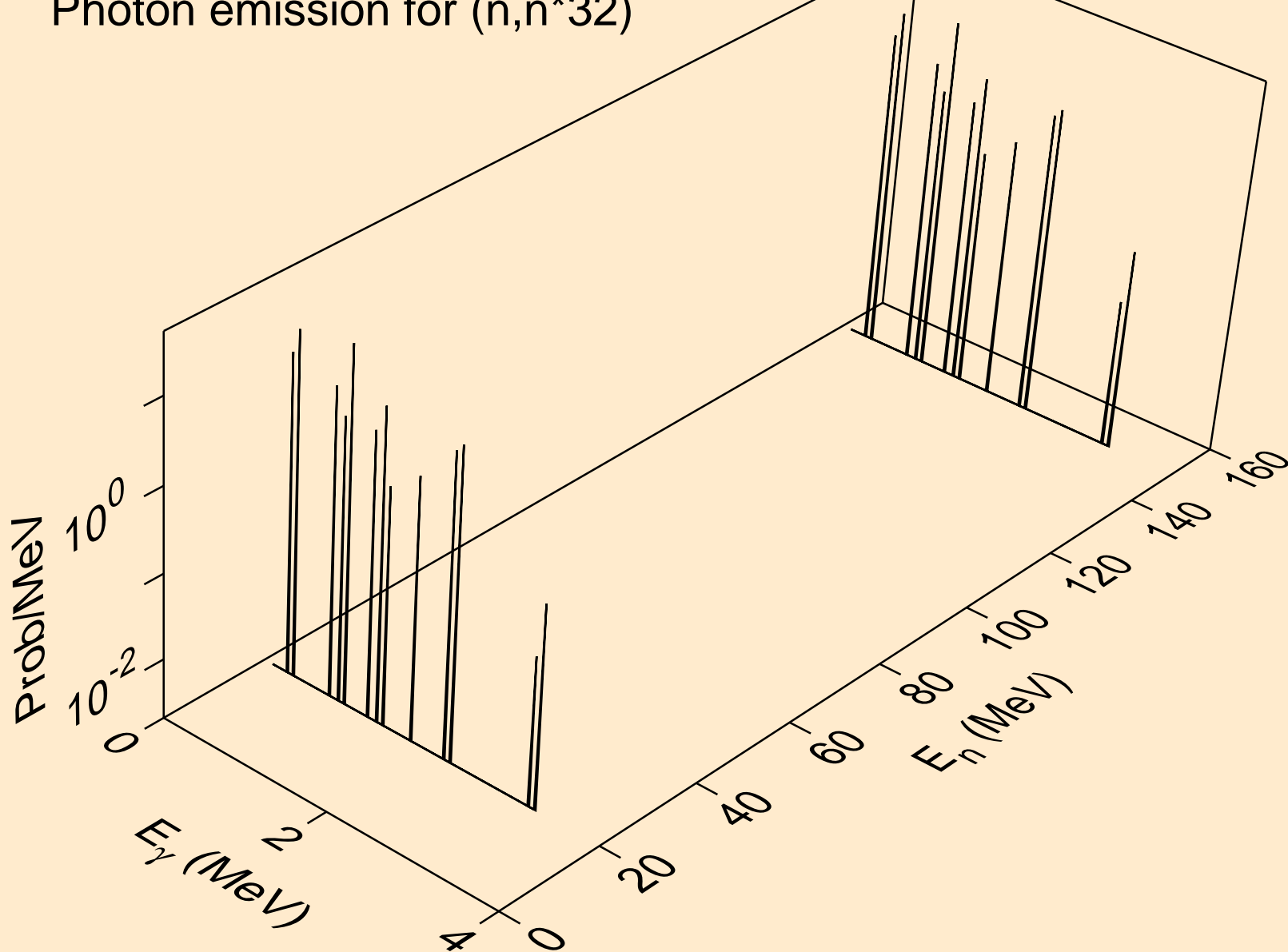

30-ZN-64 FOR FENDL-3.1 FROM FENDL-3.1 WITH NJOY2012.50+
Photon emission for (n,n*33)

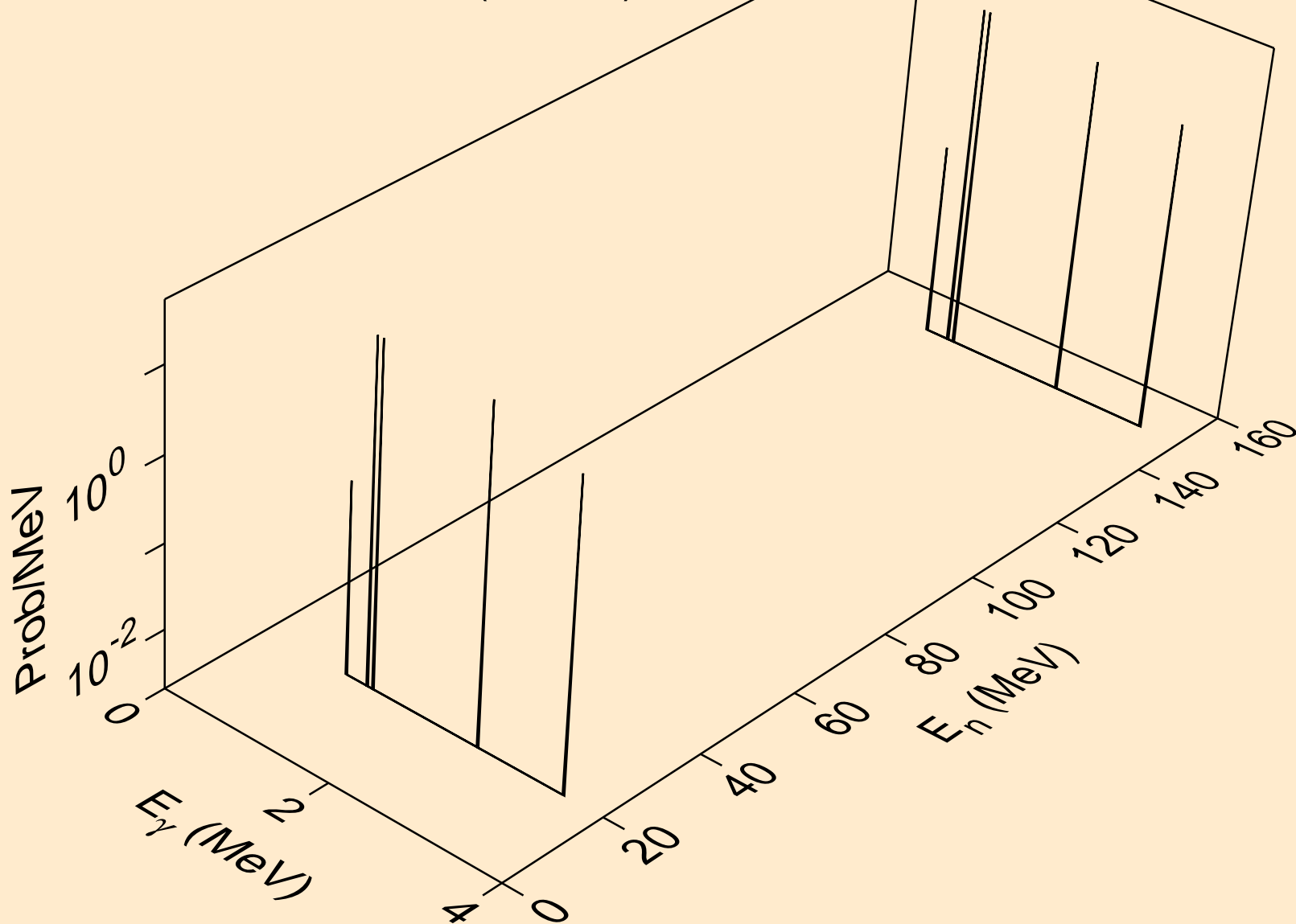

30-ZN-64 FOR FENDL-3.1 FROM FENDL-3.1 WITH NJOY2012.50+
Photon emission for (n,n*34)

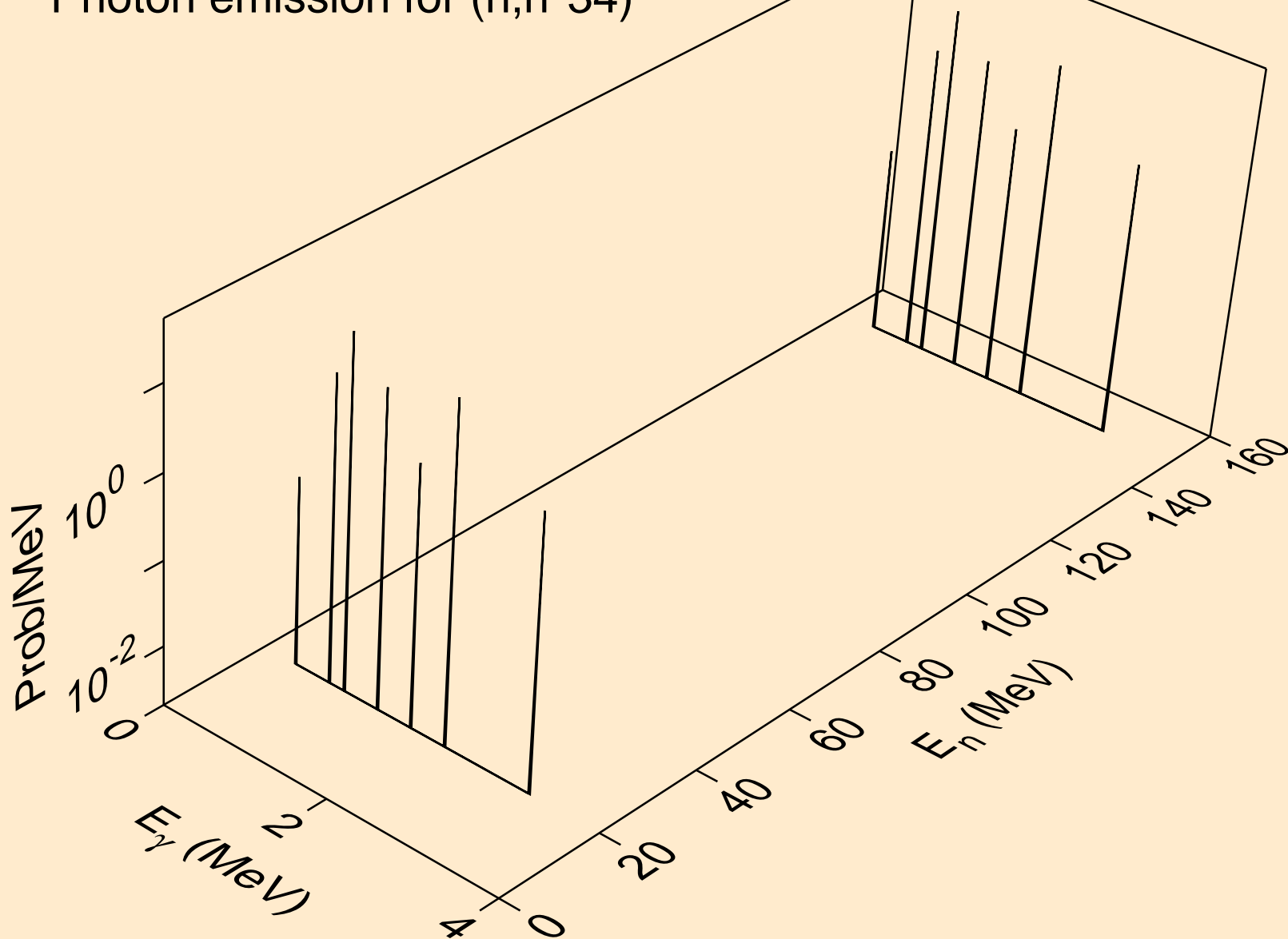

30-ZN-64 FOR FENDL-3.1 FROM FENDL-3.1 WITH NJOY2012.50+
Photon emission for (n,n*35)

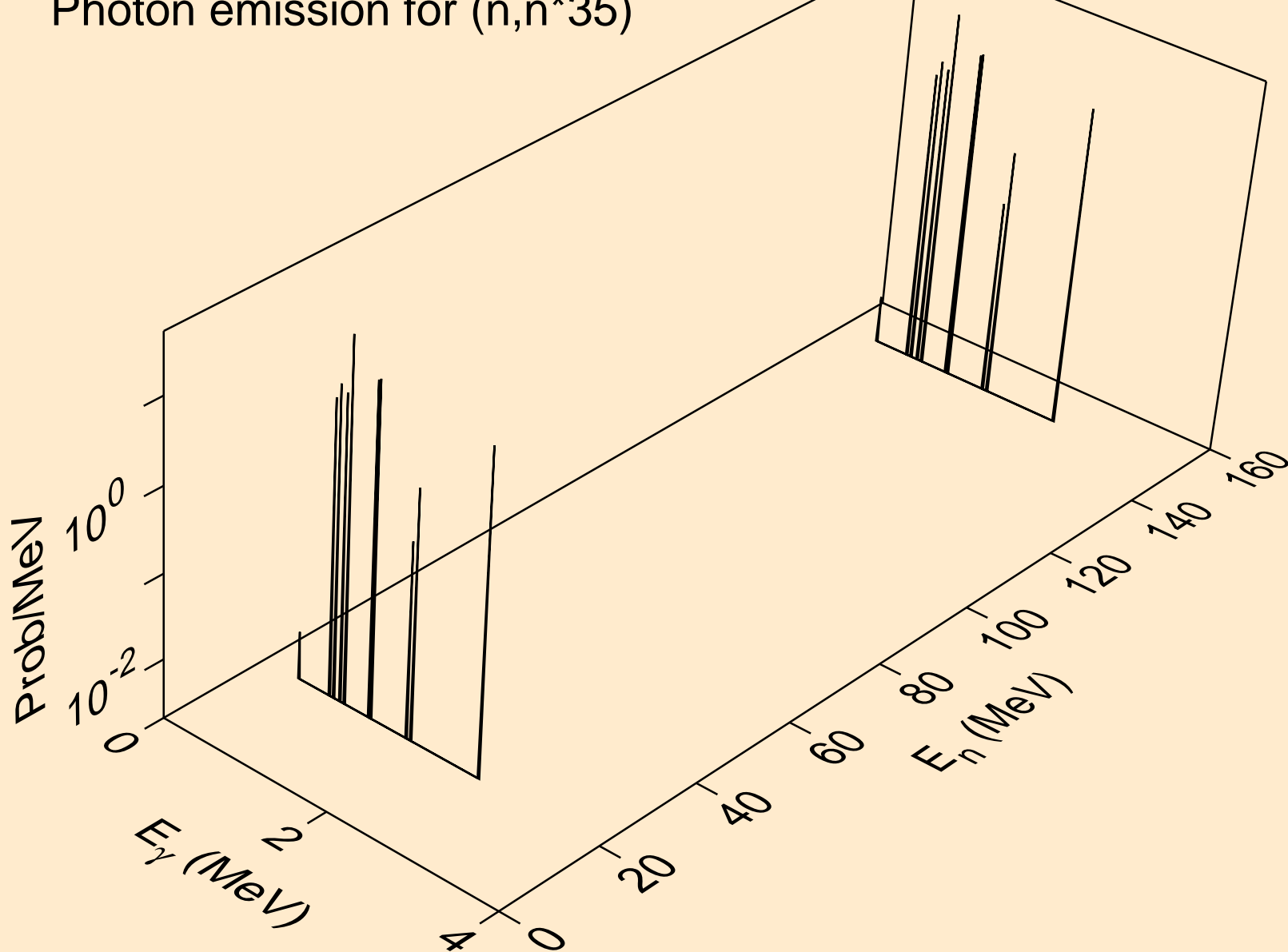

30-ZN-64 FOR FENDL-3.1 FROM FENDL-3.1 WITH NJOY2012.50+
Photon emission for (n,n*36)

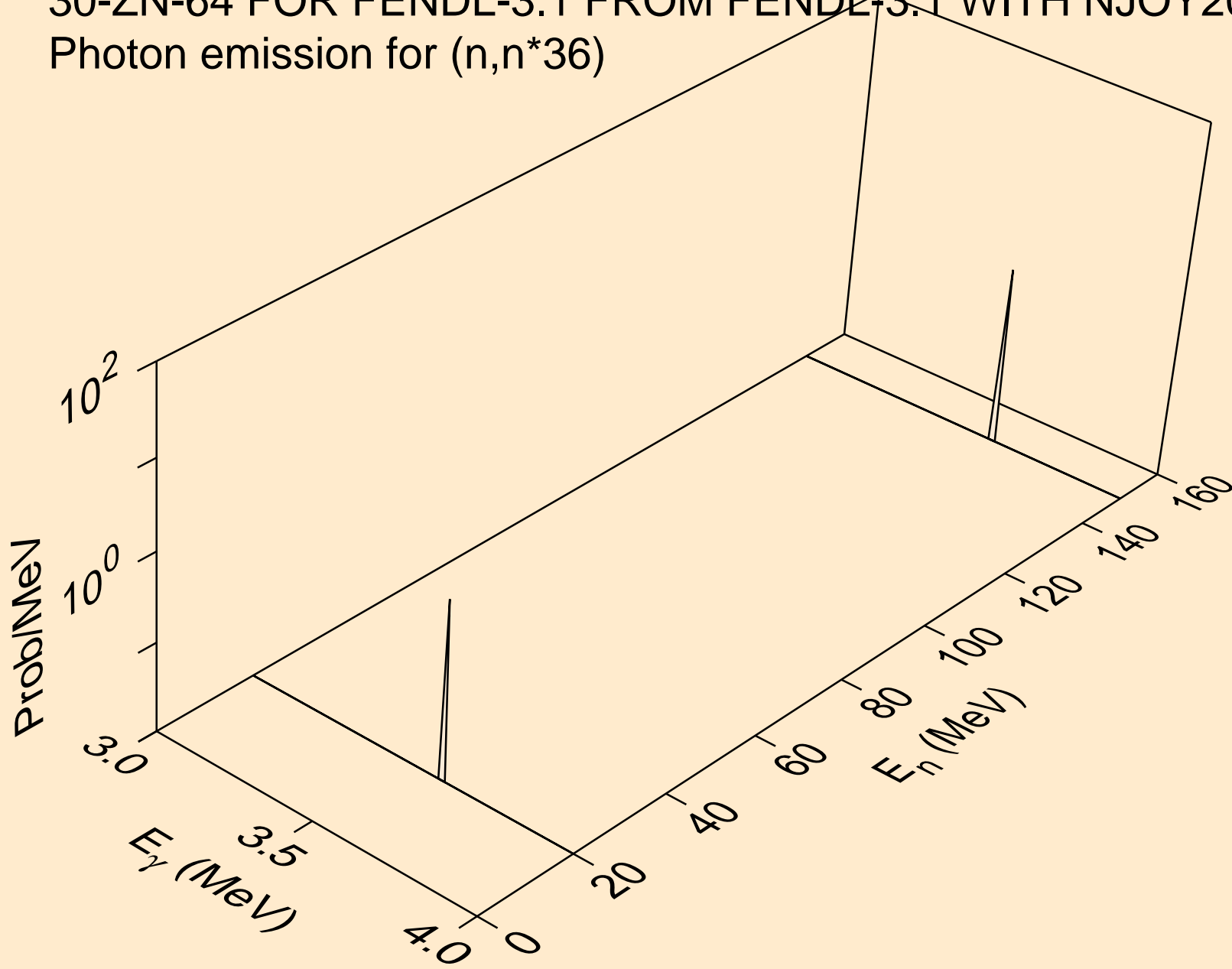

30-ZN-64 FOR FENDL-3.1 FROM FENDL-3.1 WITH NJOY2012.50+
Photon emission for (n,n*37)

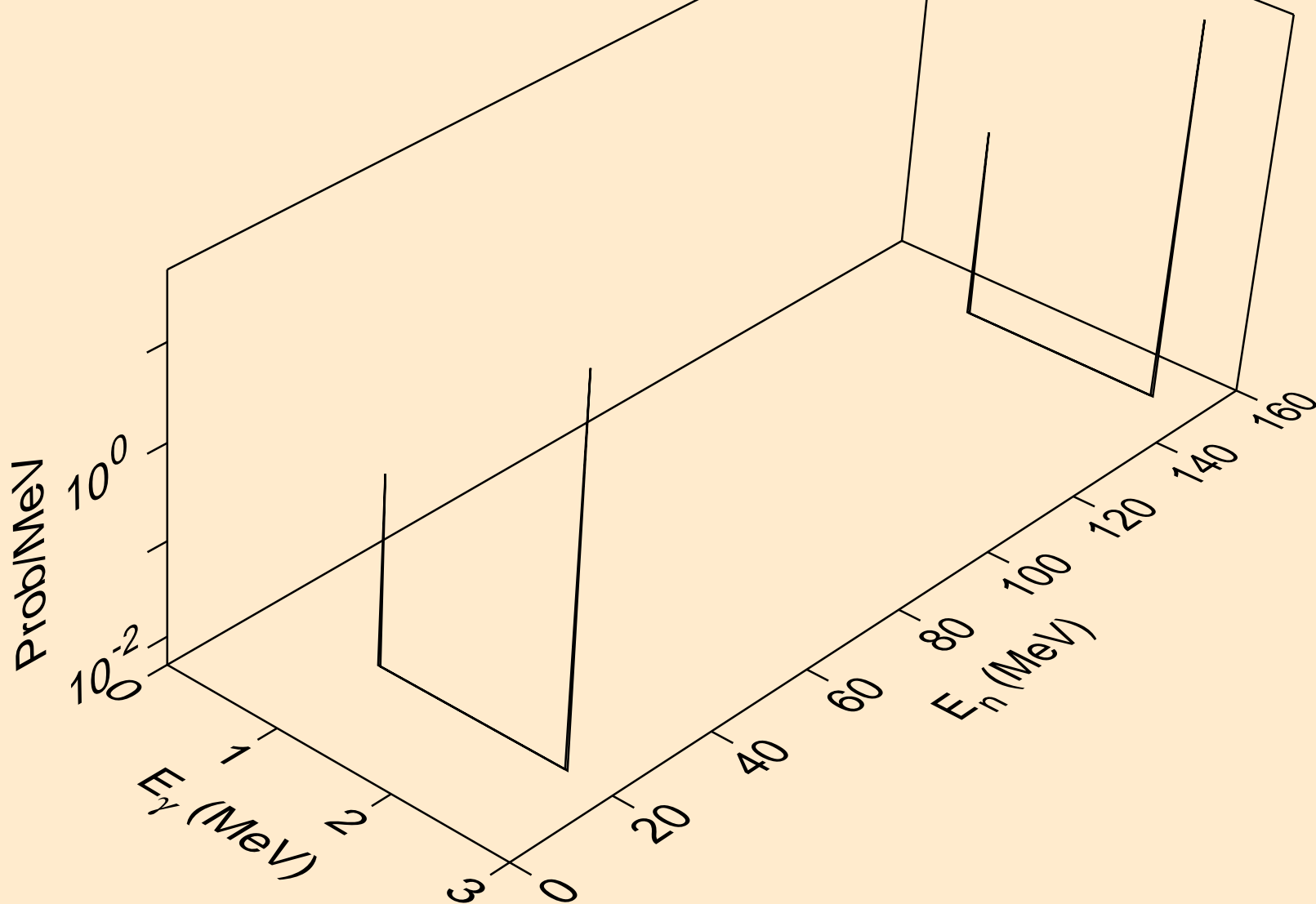

30-ZN-64 FOR FENDL-3.1 FROM FENDL-3.1 WITH NJOY2012.50+
Photon emission for (n,n*38)

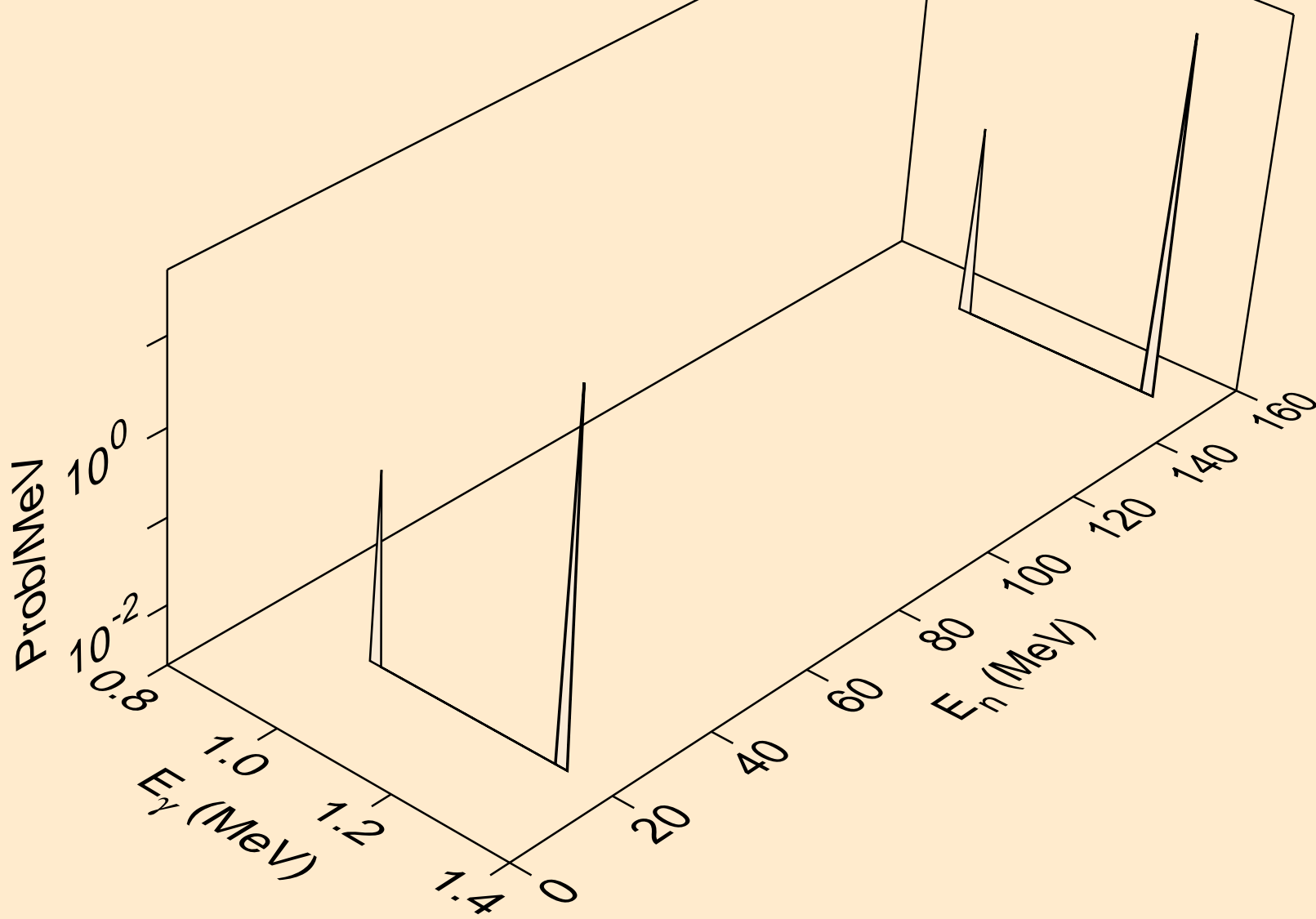

30-ZN-64 FOR FENDL-3.1 FROM FENDL-3.1 WITH NJOY2012.50+
Photon emission for (n,n*39)

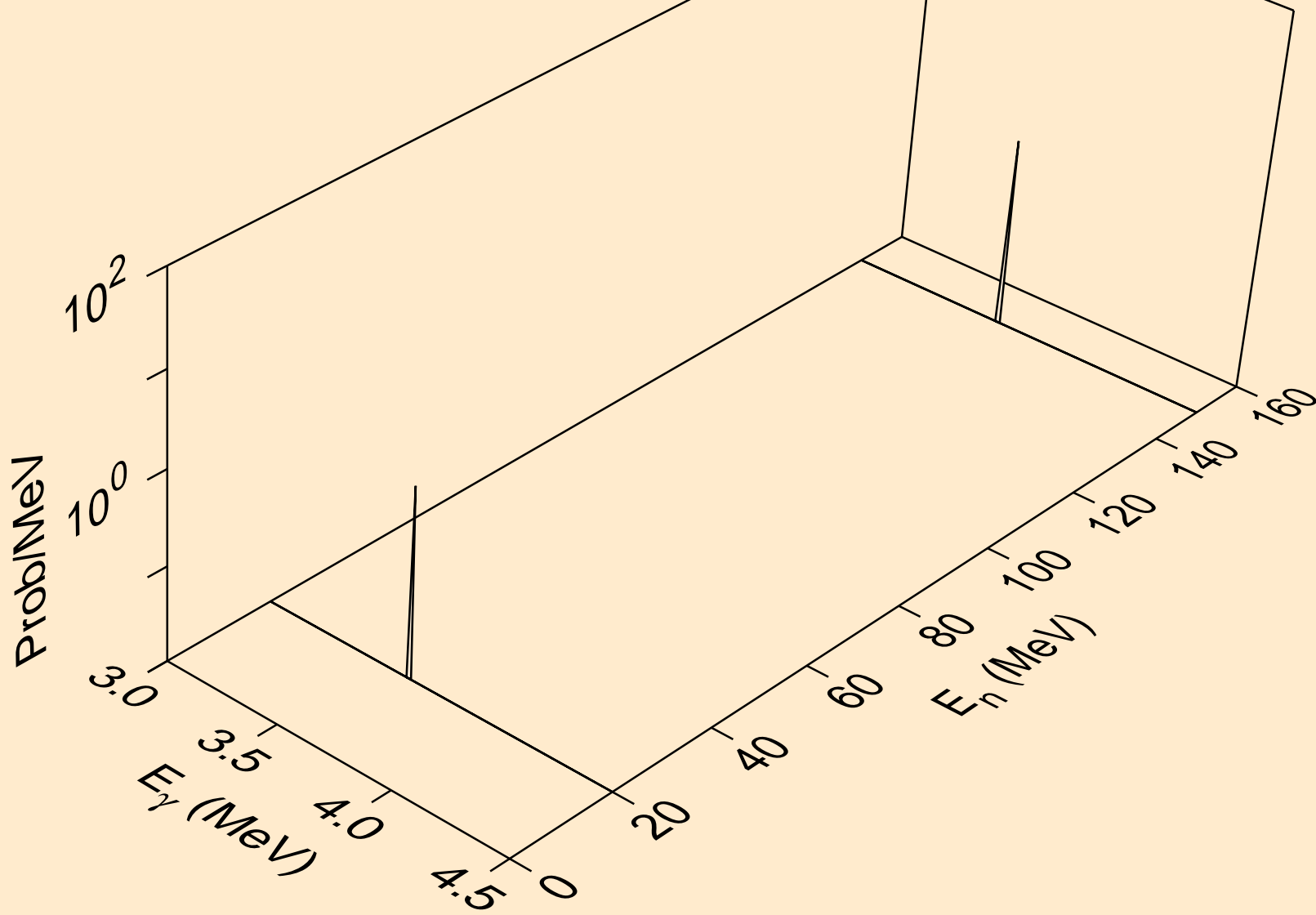

30-ZN-64 FOR FENDL-3.1 FROM FENDL-3.1 WITH NJOY2012.50+
Photon emission for (n,n*40)

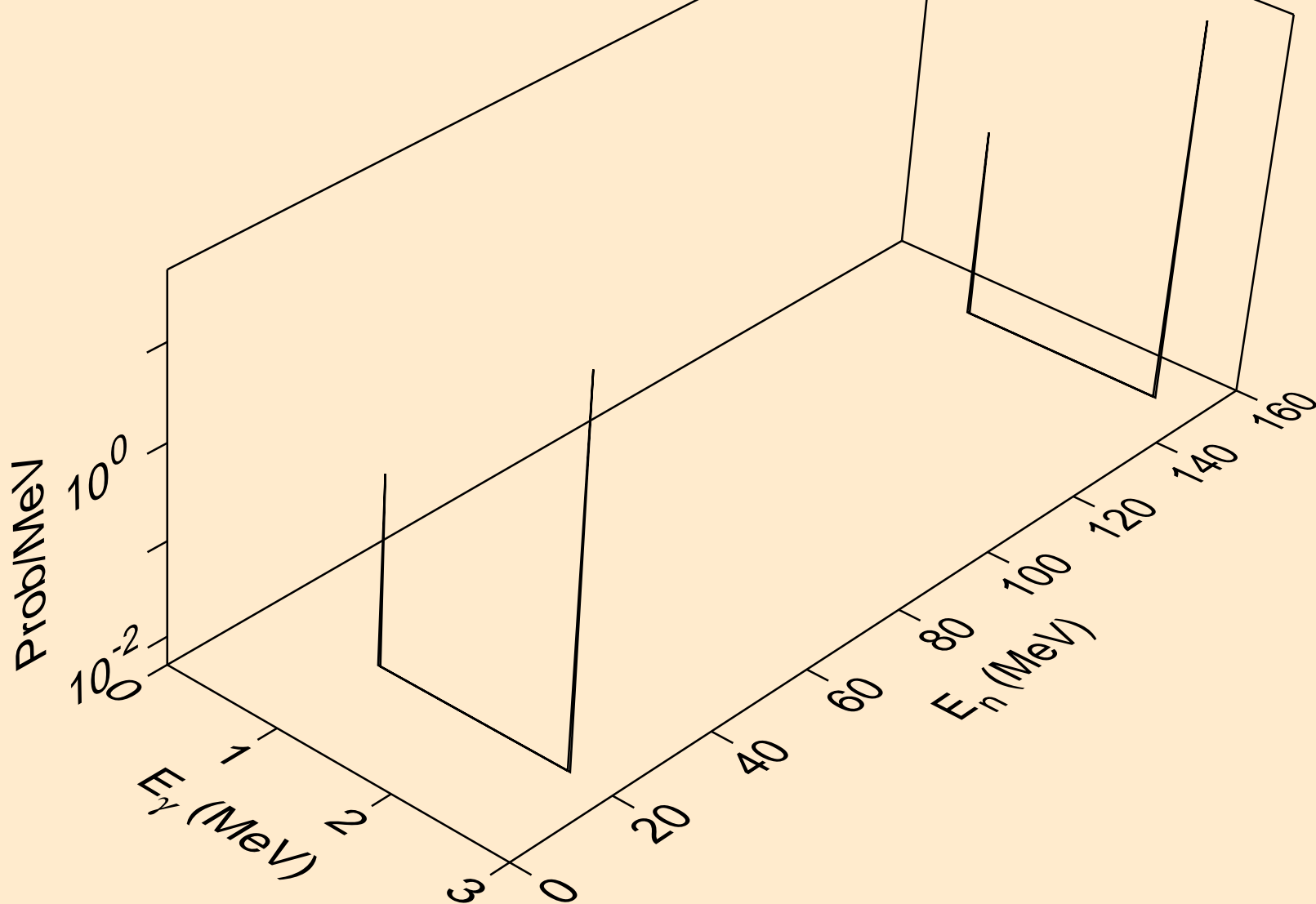

30-ZN-64 FOR FENDL-3.1 FROM FENDL-3.1 WITH NJOY2012.50+
Photon emission for (n,n*c)

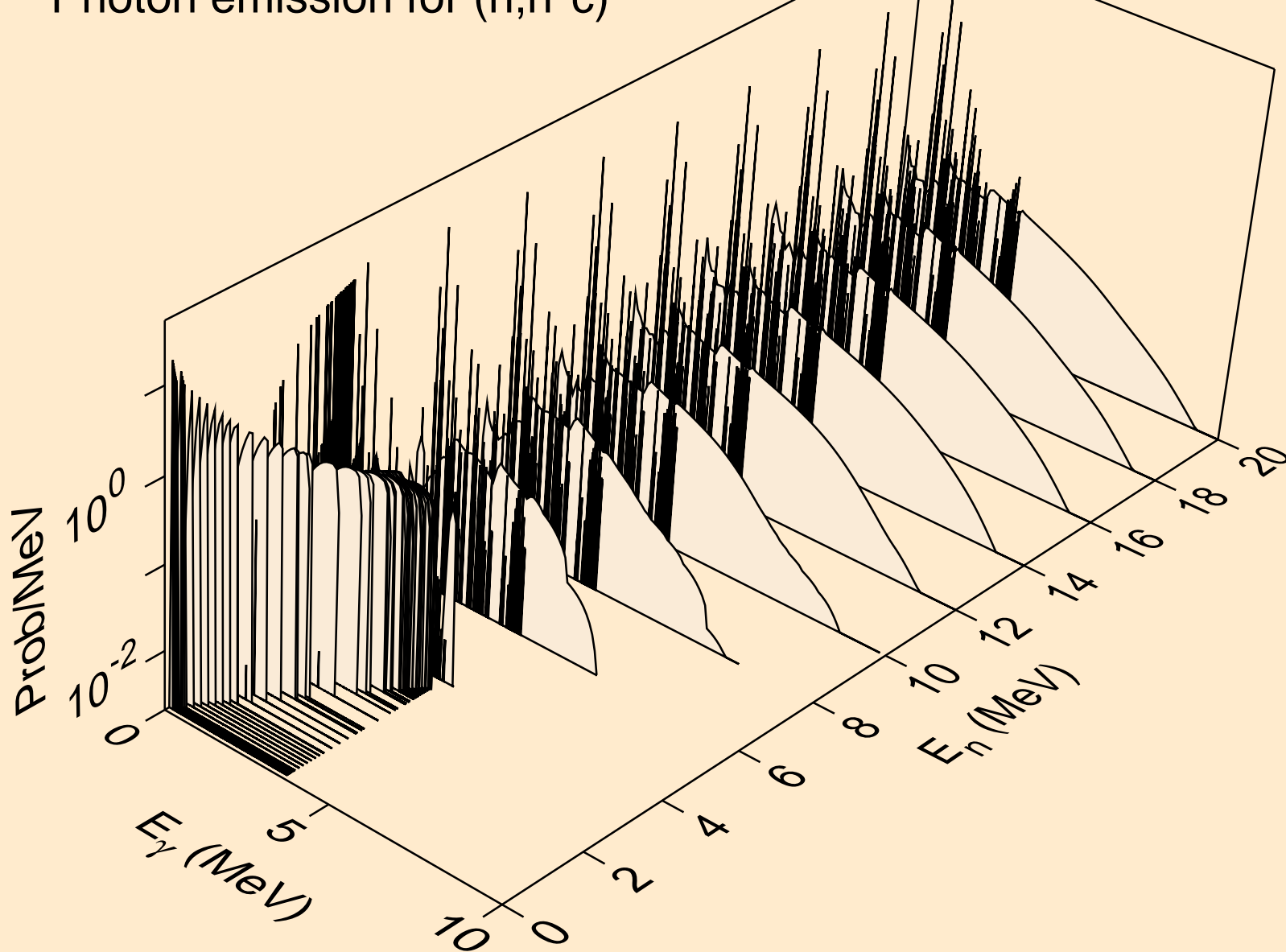

30-ZN-64 FOR FENDL-3.1 FROM FENDL-3.1 WITH NJOY2012.50+
Photon emission for (n,gma)

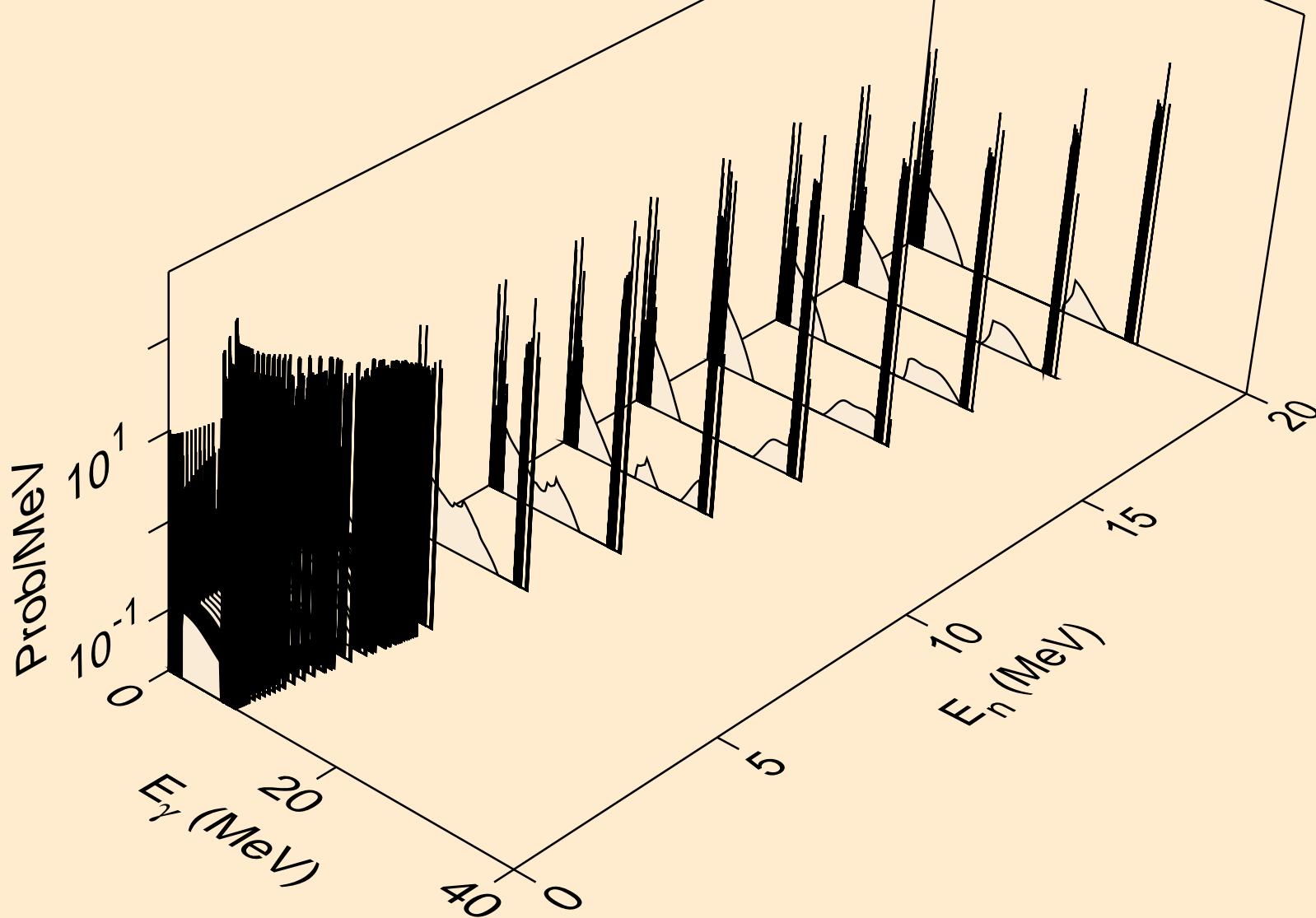

30-ZN-64 FOR FENDL-3.1 FROM FENDL-3.1 WITH NJOY2012.50+
thermal capture photon spectrum

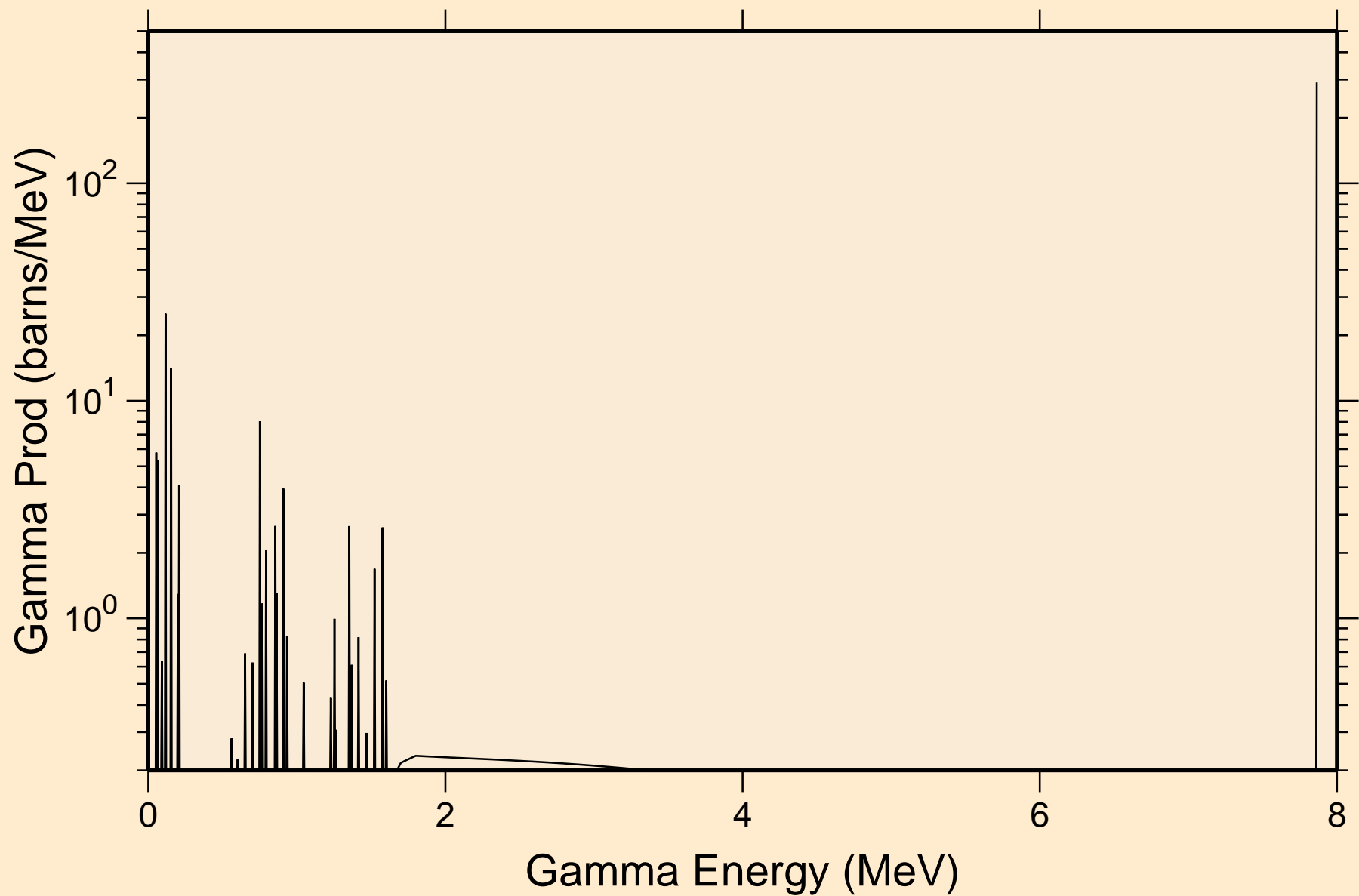

30-ZN-64 FOR FENDL-3.1 FROM FENDL-3.1 WITH NJOY2012.50+
14 MeV photon spectrum

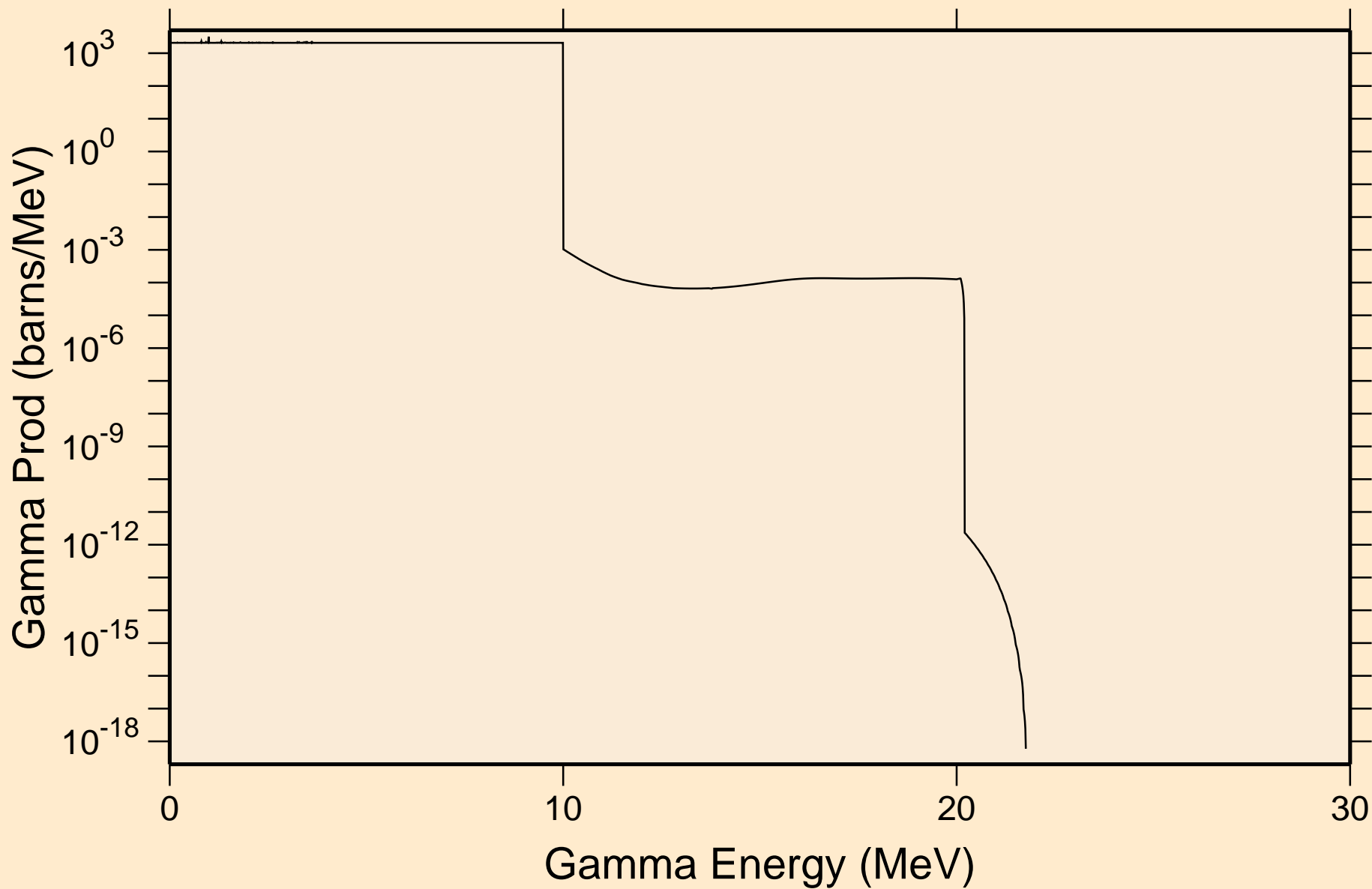

30-ZN-64 FOR FENDL-3.1 FROM FENDL-3.1 WITH NJOY2012.50+

Particle heating contributions

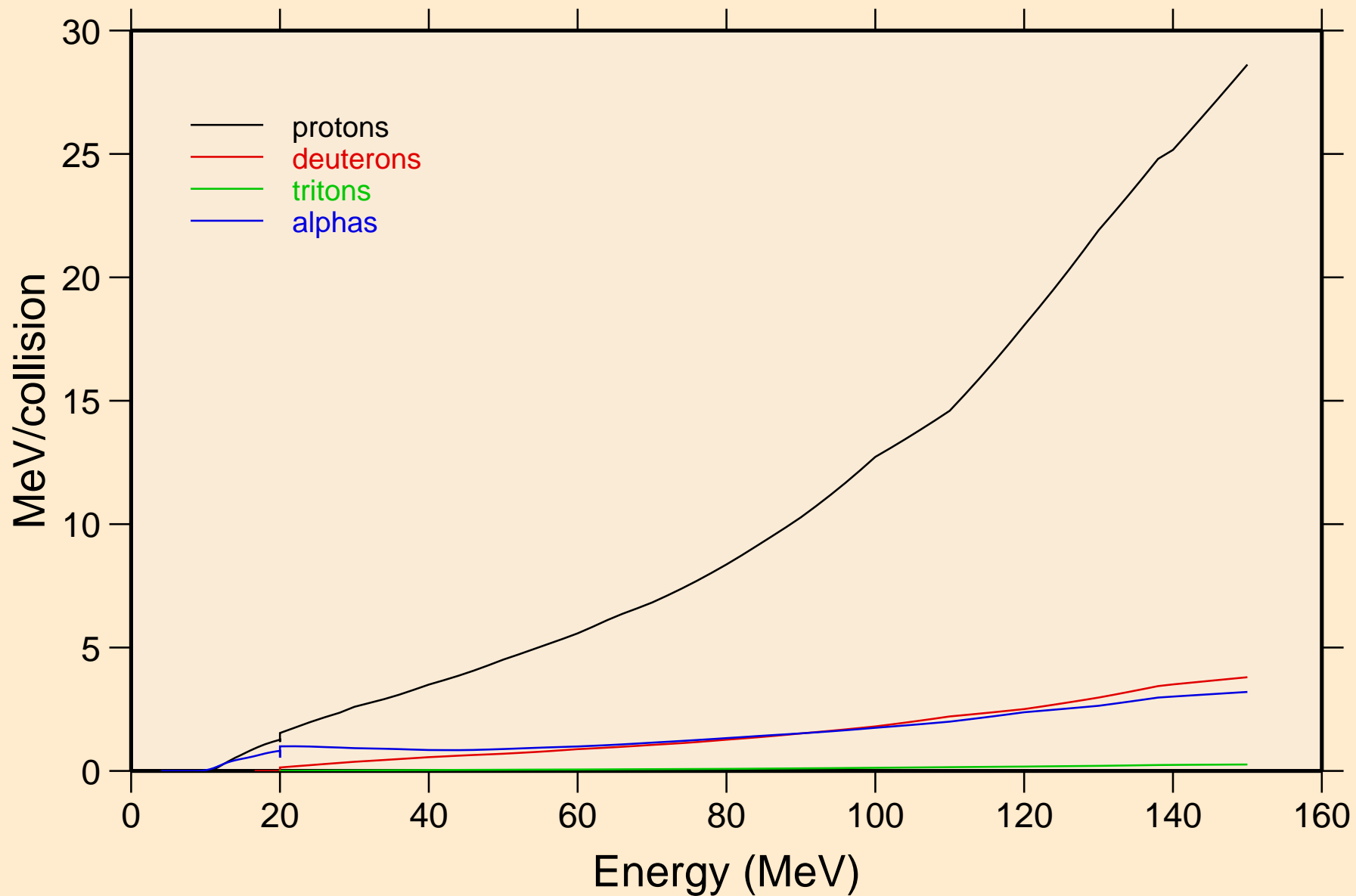

30-ZN-64 FOR FENDL-3.1 FROM FENDL-3.1 WITH NJOY2012.50+

Recoil Heating

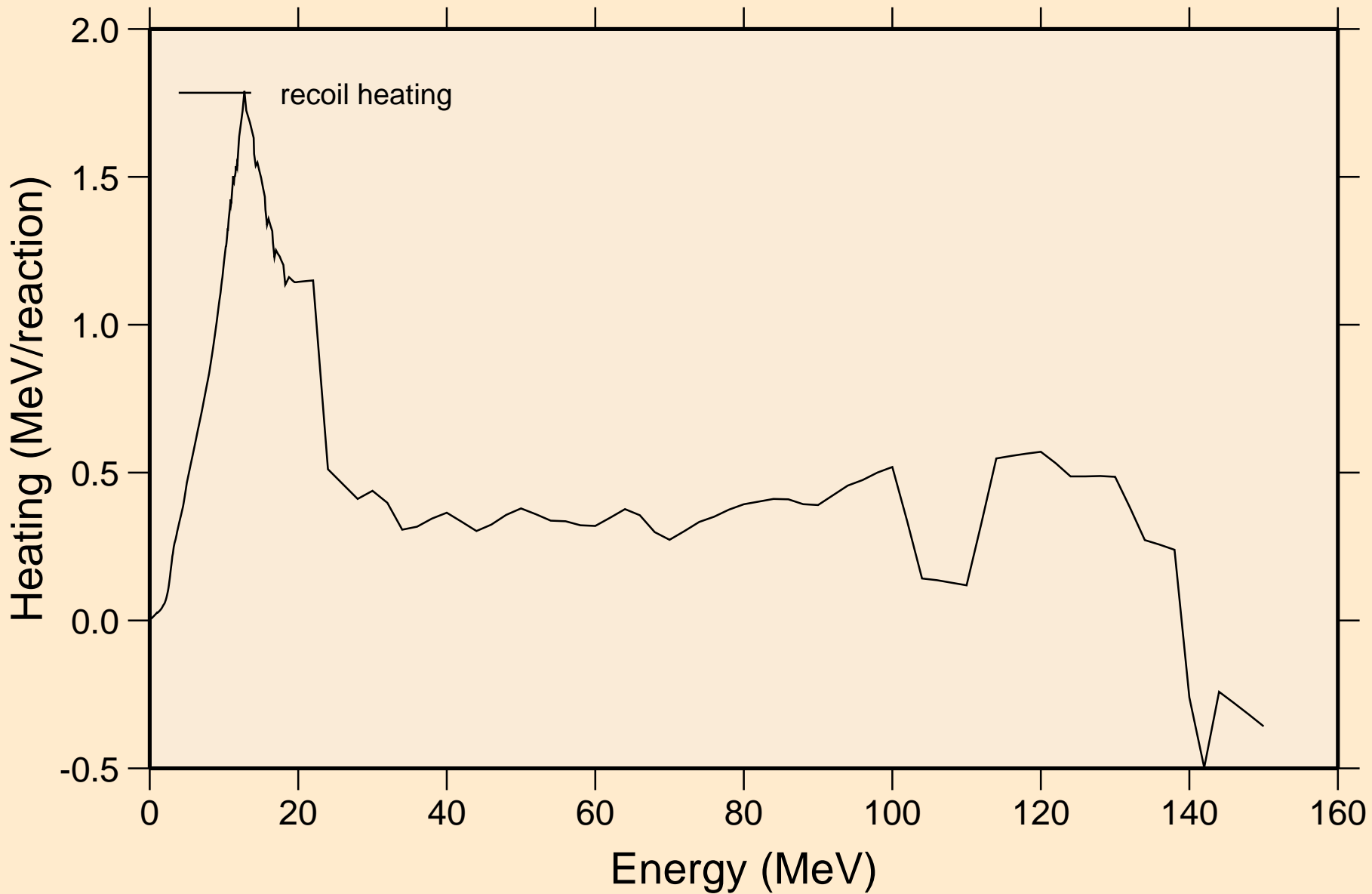

30-ZN-64 FOR FENDL-3.1 FROM FENDL-3.1 WITH NJOY2012.50+

Particle production cross sections

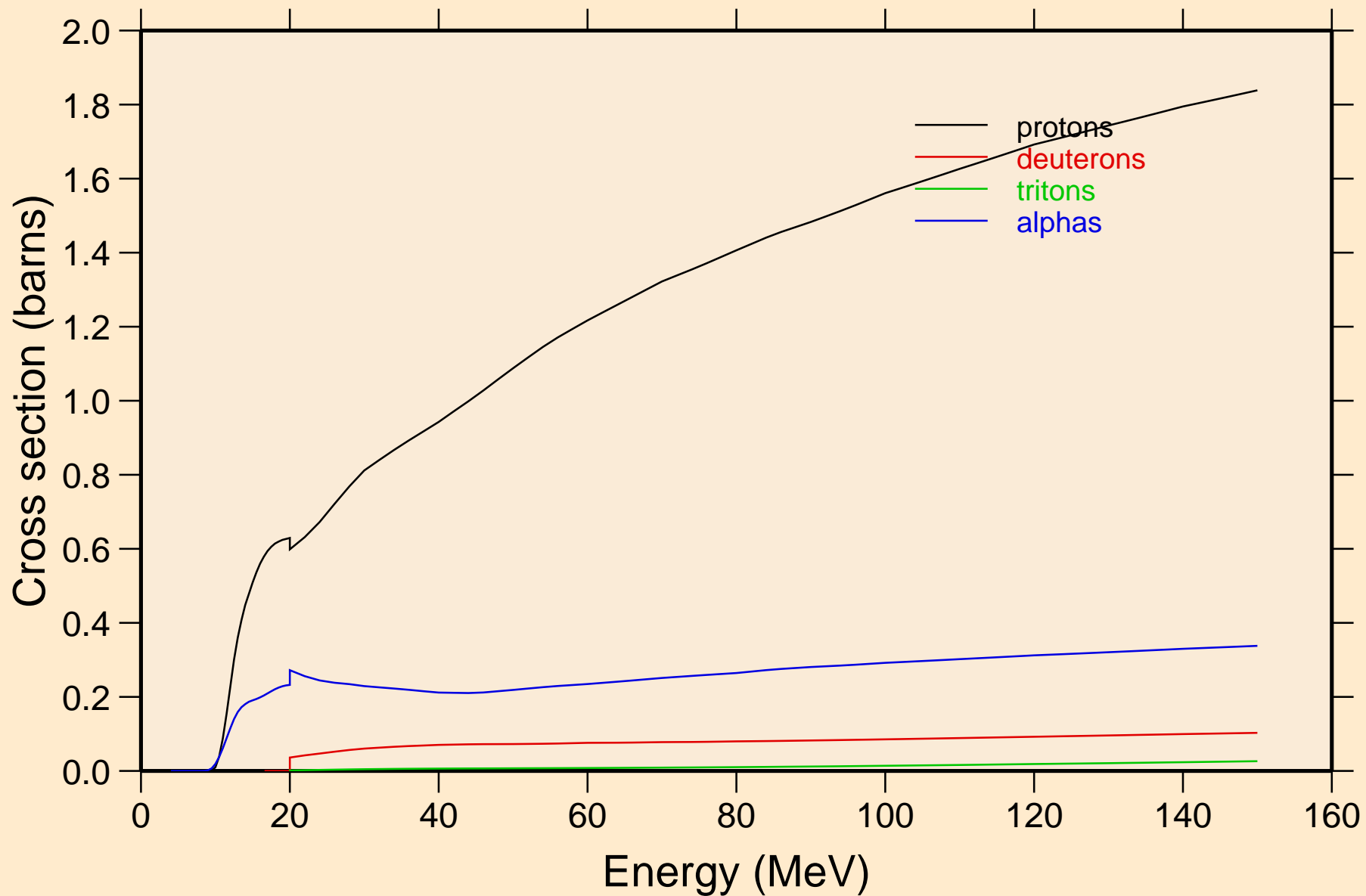

30-ZN-64 FOR FENDL-3.1 FROM FENDL-3.1 WITH NJOY2012.50+
protons from (n,x)

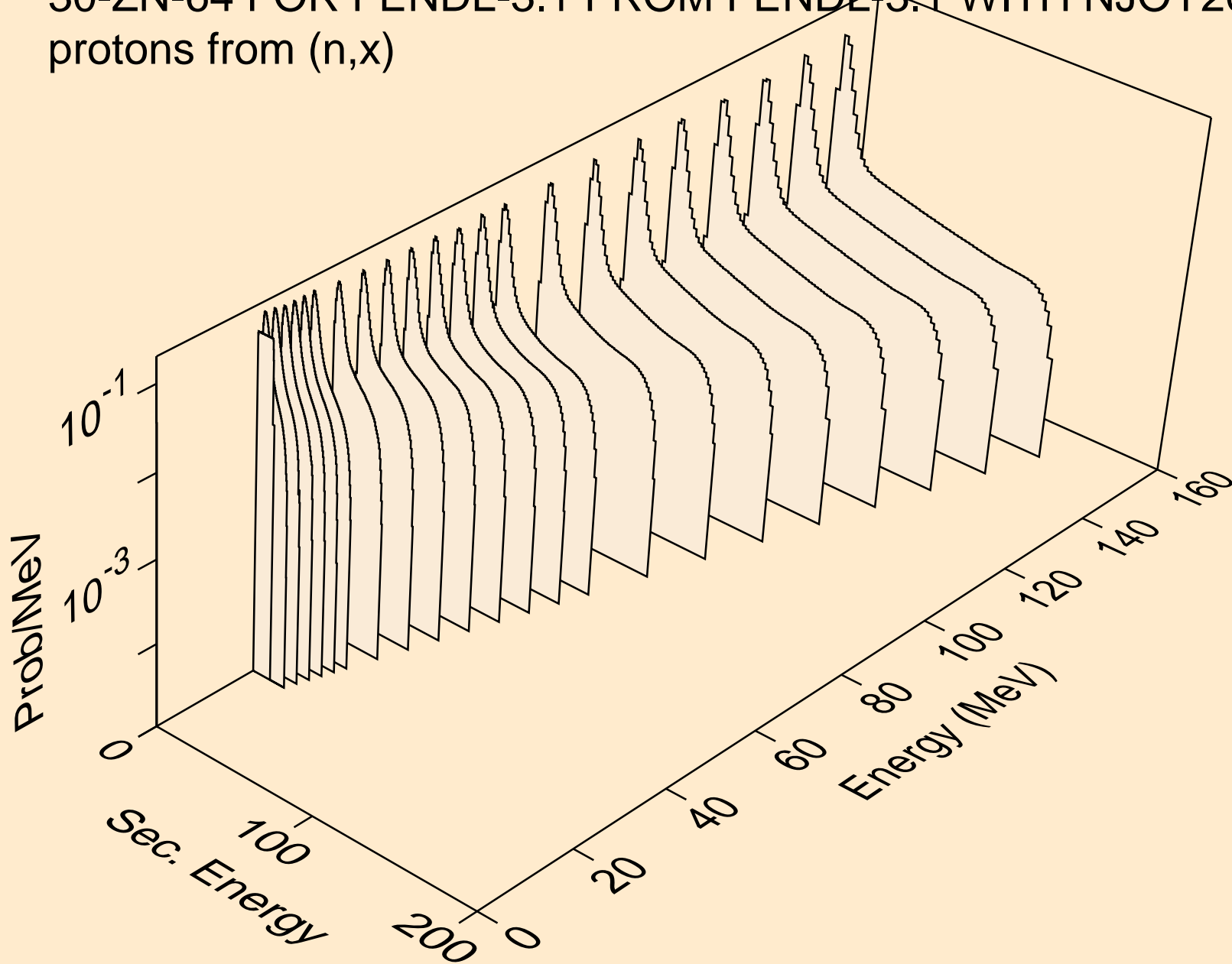

30-ZN-64 FOR FENDL-3.1 FROM FENDL-3.1 WITH NJOY2012.50+
protons from (n,n*)p

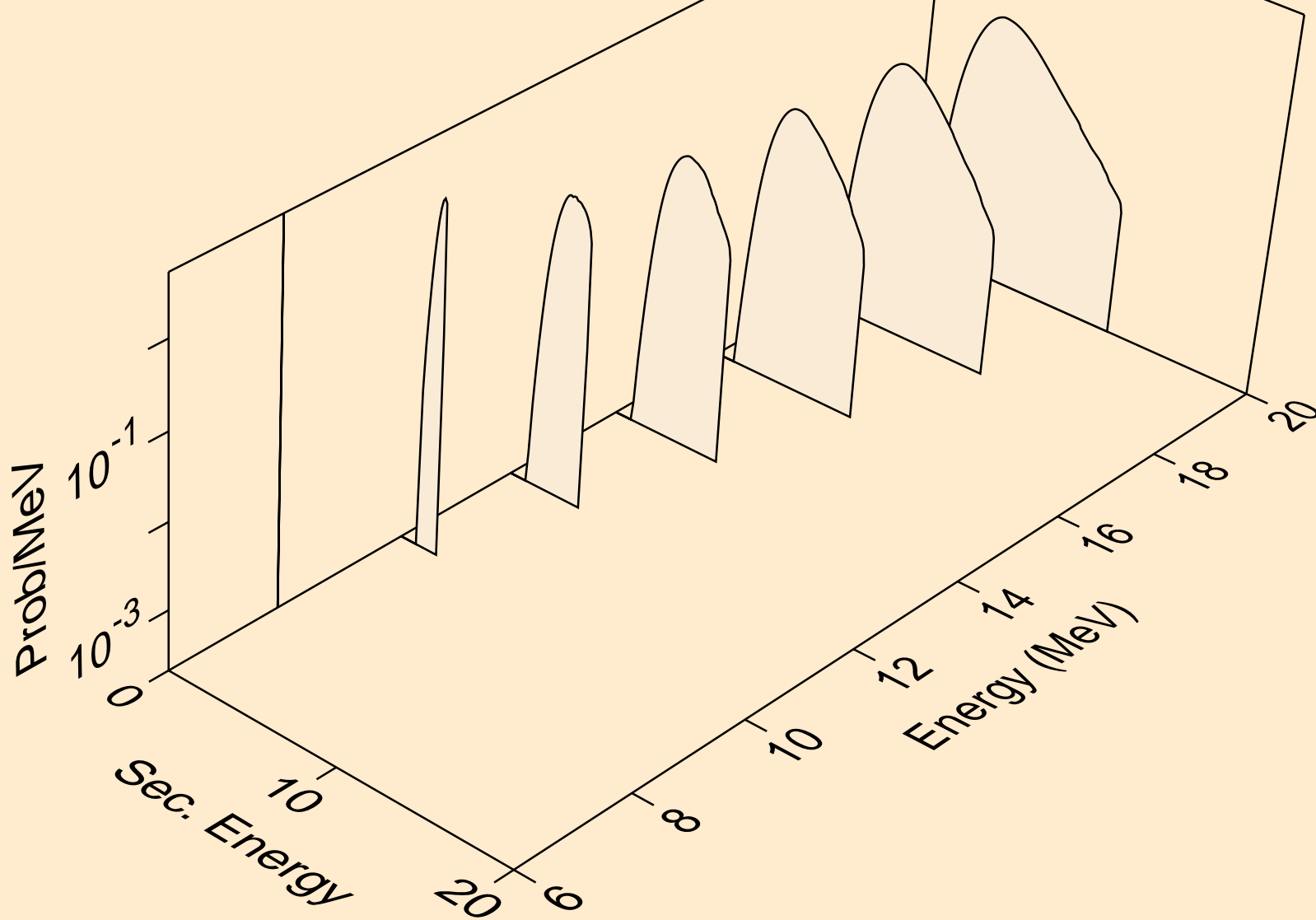

30-ZN-64 FOR FENDL-3.1 FROM FENDL-3.1 WITH NJOY2012.50+
protons from (n,2np)

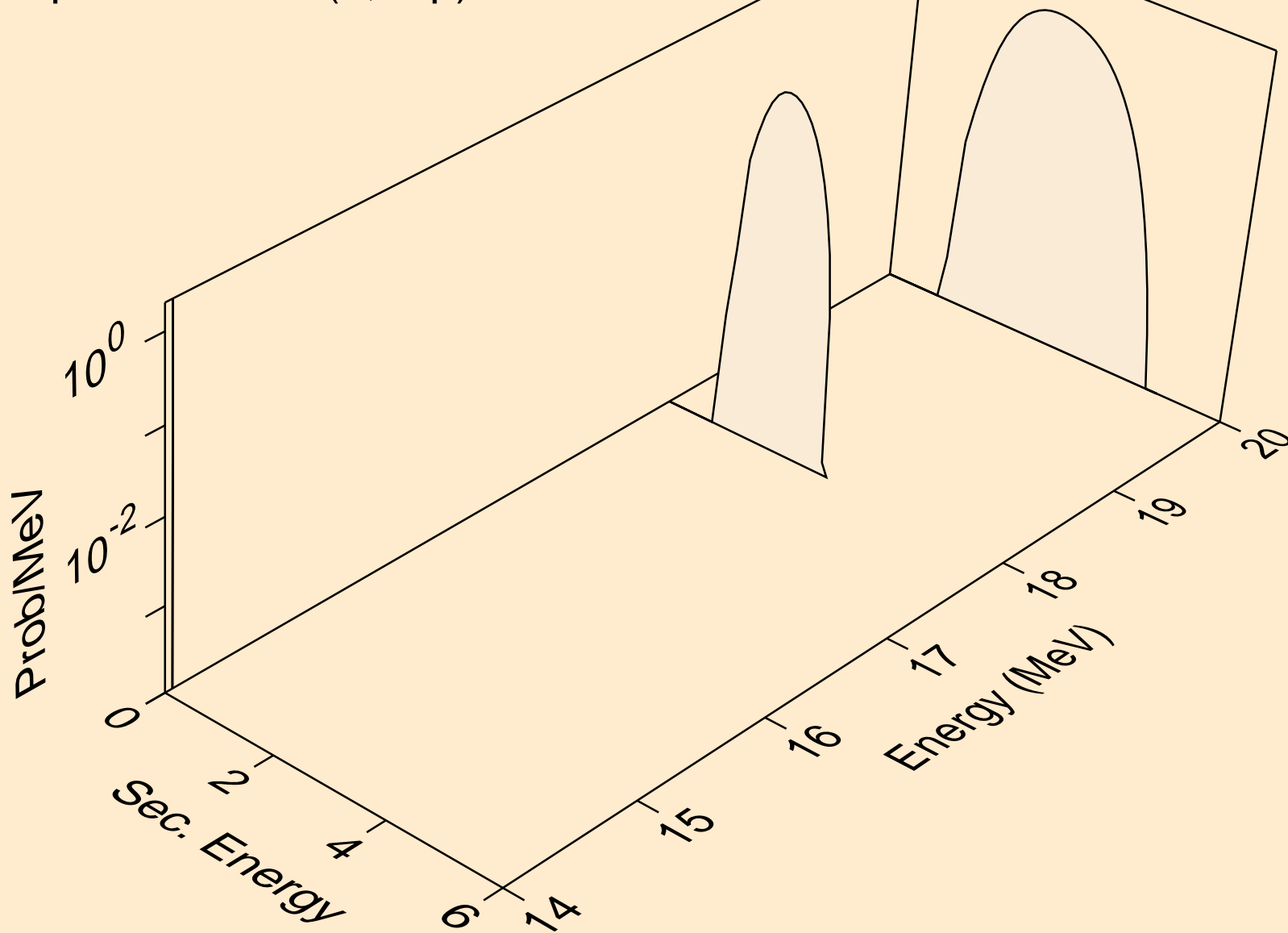

30-ZN-64 FOR FENDL-3.1 FROM FENDL-3.1 WITH NJOY2012.50+
deuterons from (n,x)

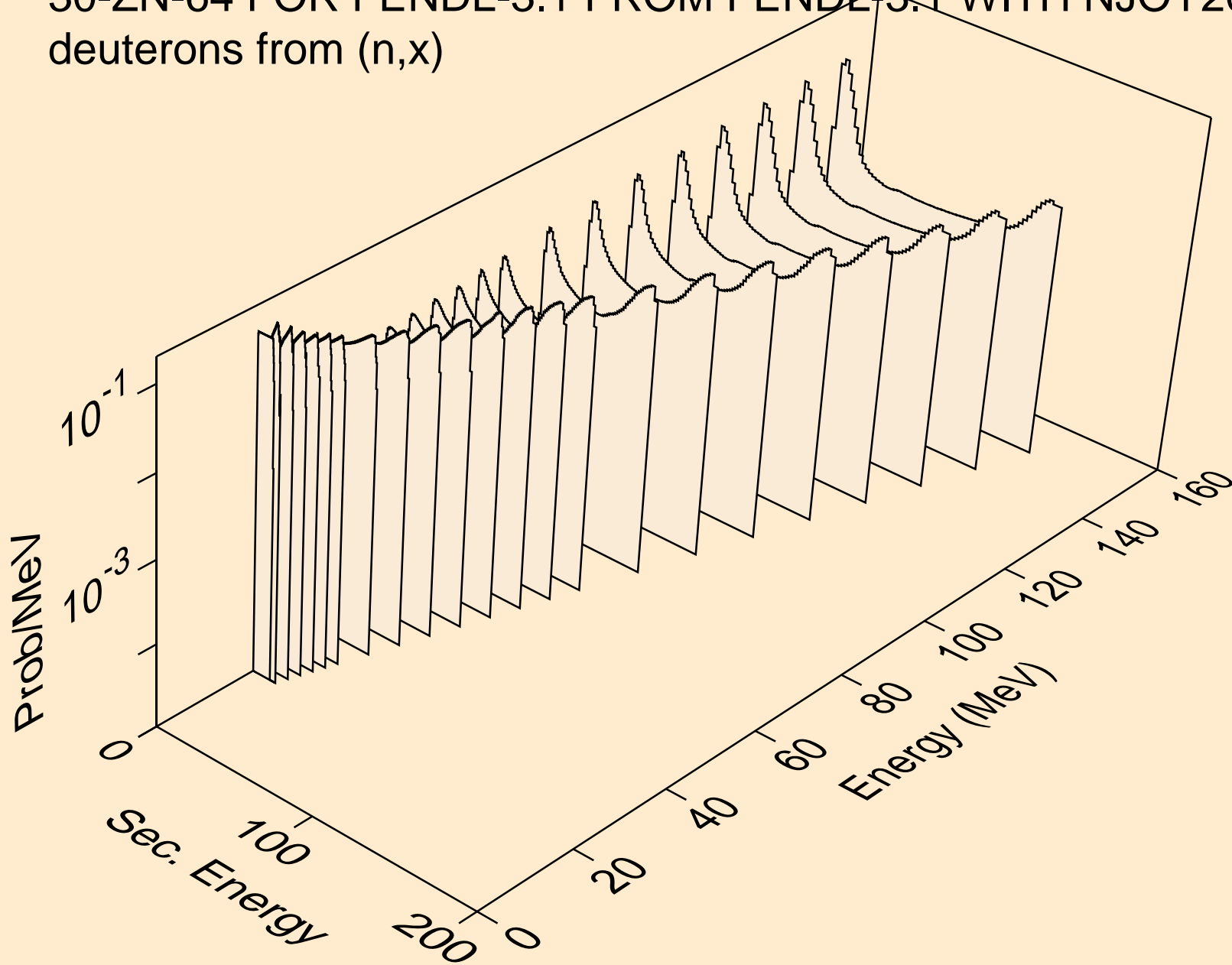

30-ZN-64 FOR FENDL-3.1 FROM FENDL-3.1 WITH NJOY2012.50+
deuterons from (n,n*)d

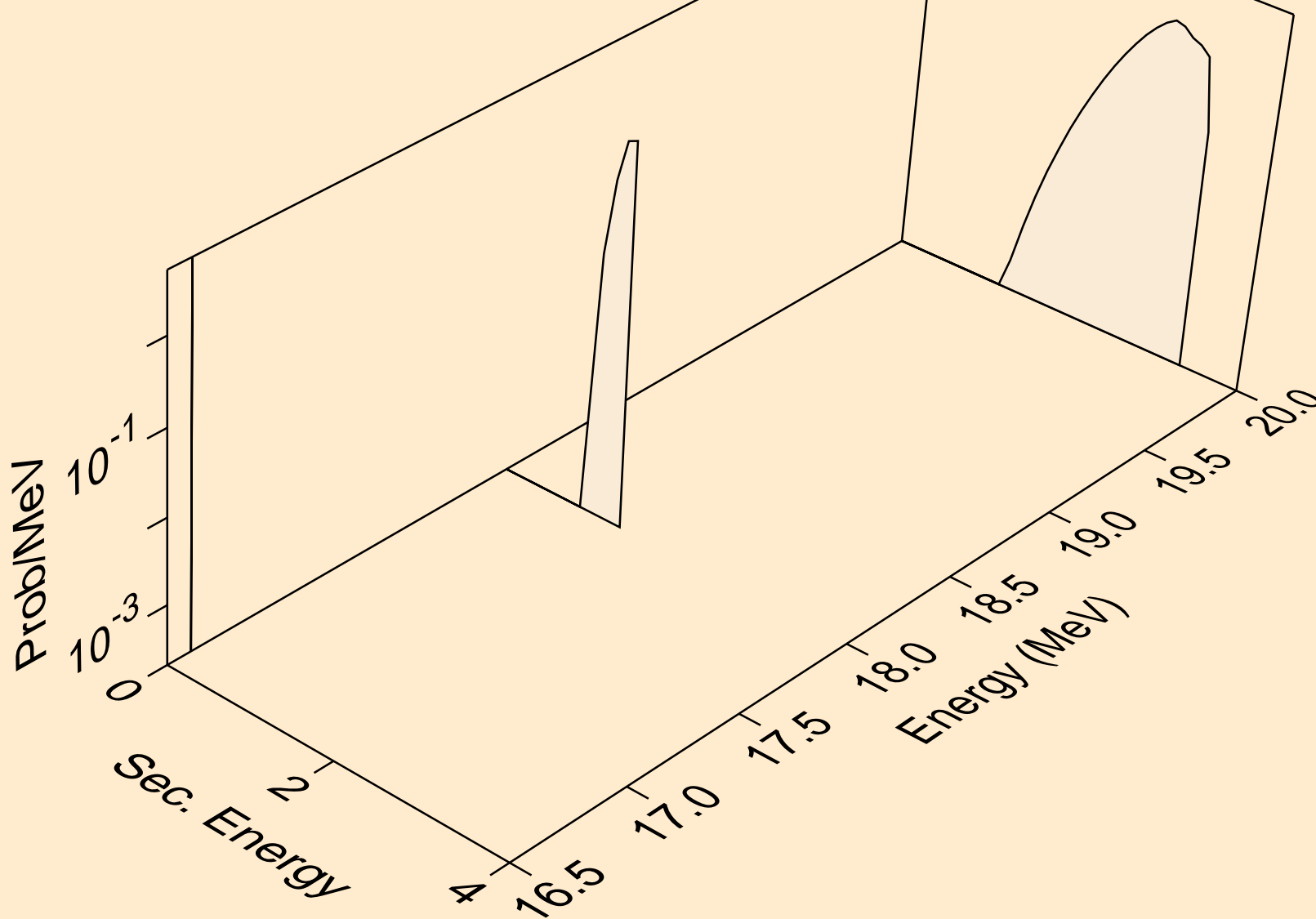

30-ZN-64 FOR FENDL-3.1 FROM FENDL-3.1 WITH NJOY2012.50+
tritons from (n,x)

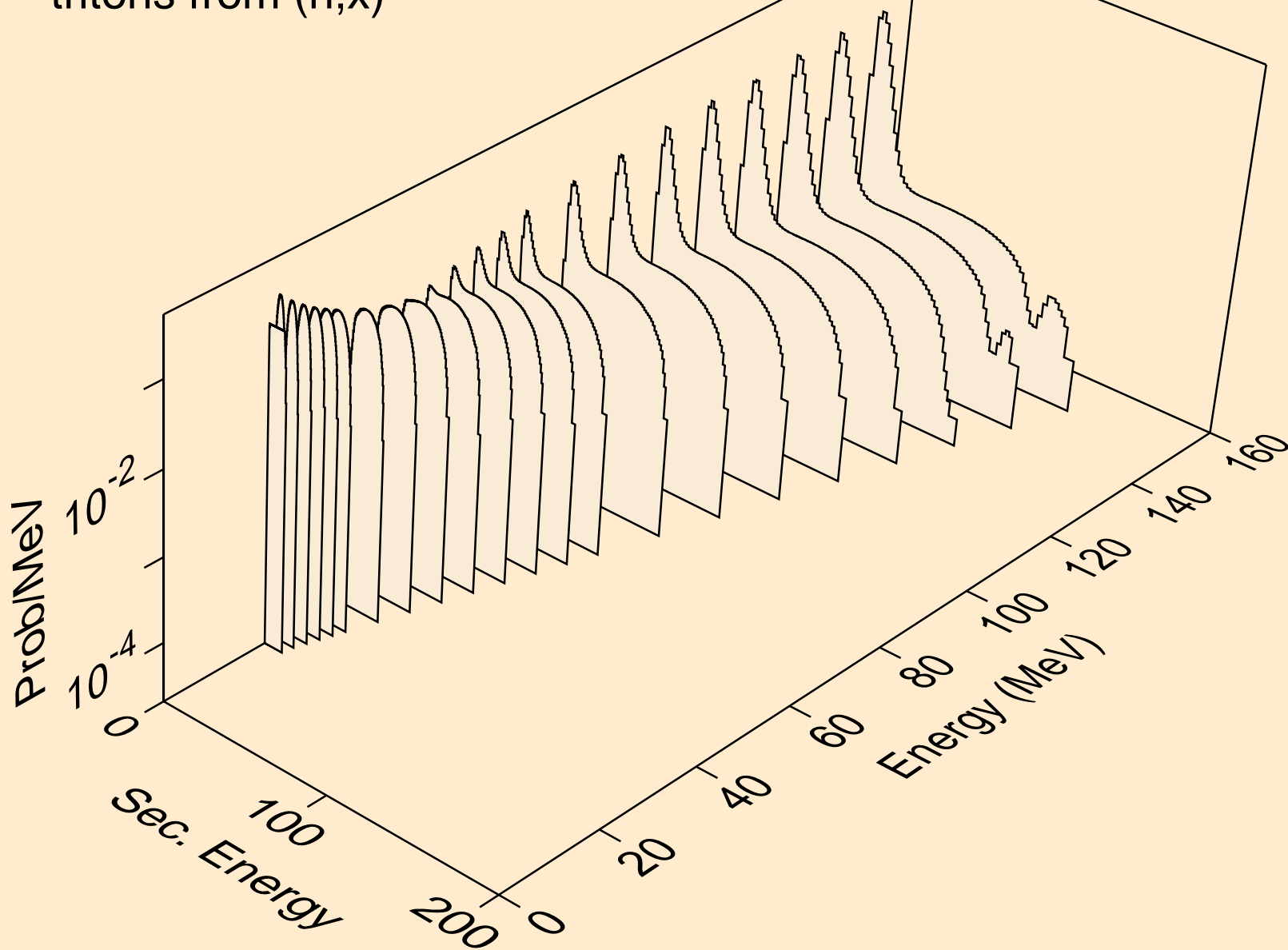

30-ZN-64 FOR FENDL-3.1 FROM FENDL-3.1 WITH NJOY2012.50+
alphas from (n,x)

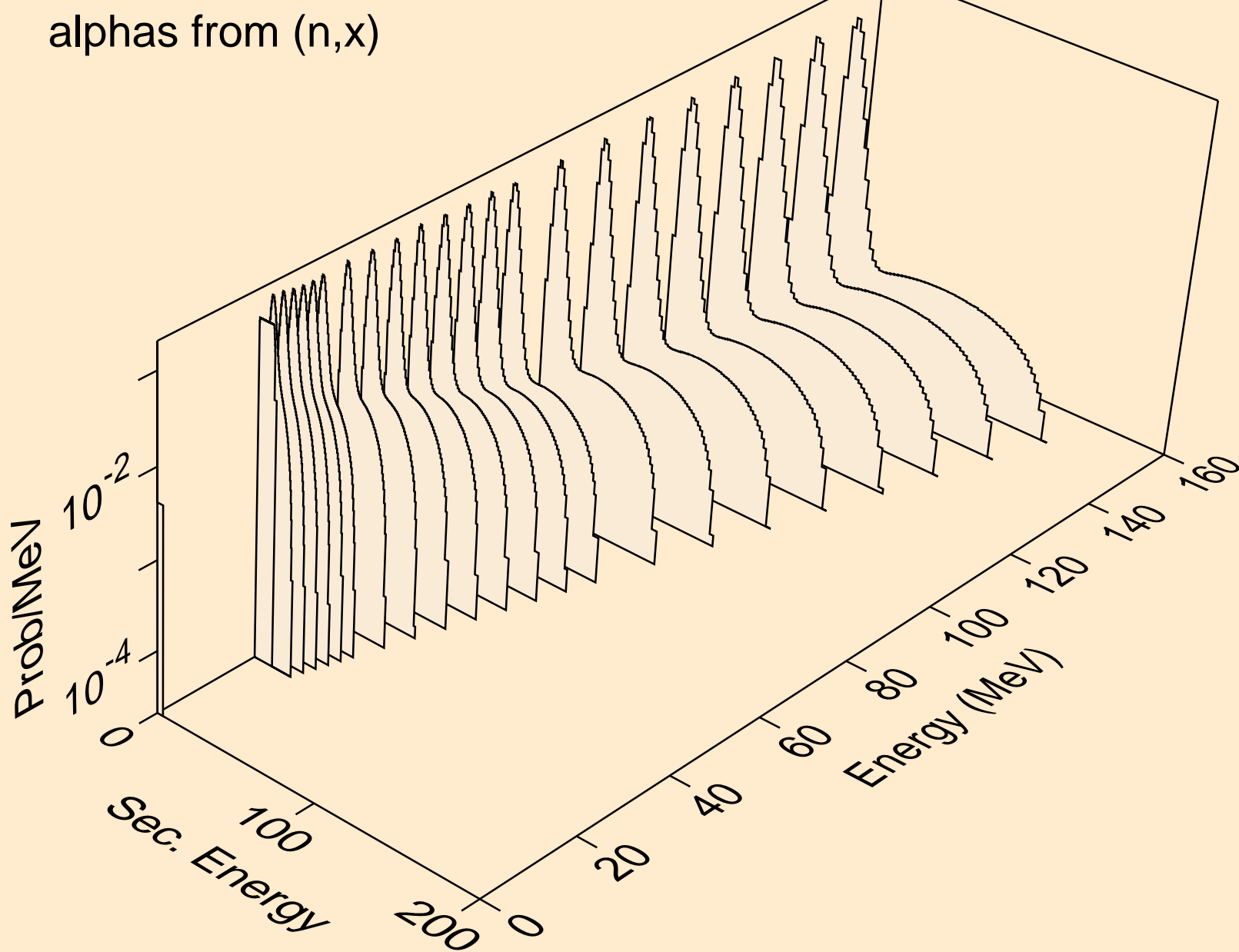

30-ZN-64 FOR FENDL-3.1 FROM FENDL-3.1 WITH NJOY2012.50+
alphas from (n,n*)a

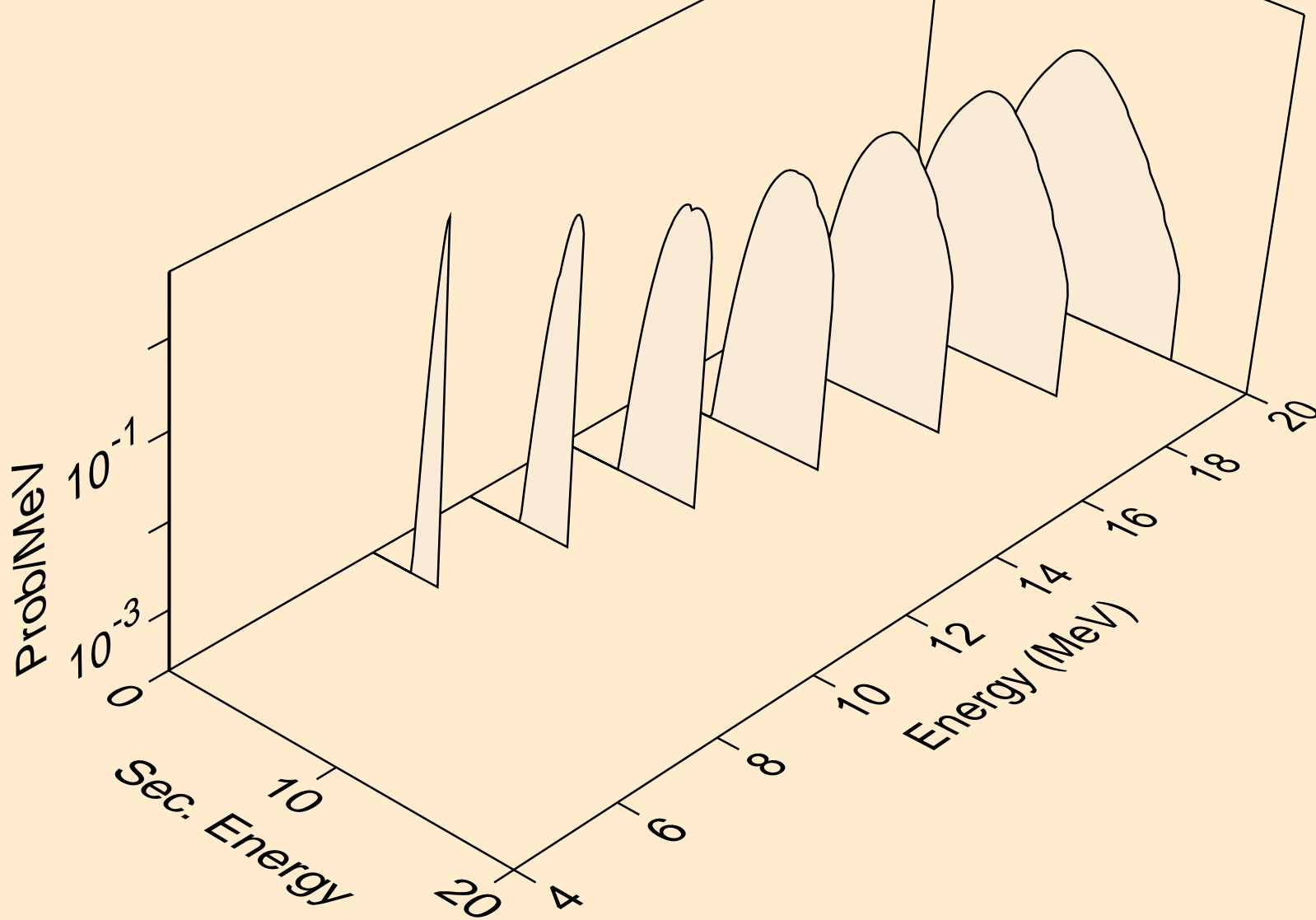

30-ZN-64 FOR FENDL-3.1 FROM FENDL-3.1 WITH NJOY2012.50+
alphas from (n,2n)a

