

50-SN-115 FOR FENDL-3.1 FROM FENDL-3.1 WITH NJOY2012.50  
Principal cross sections

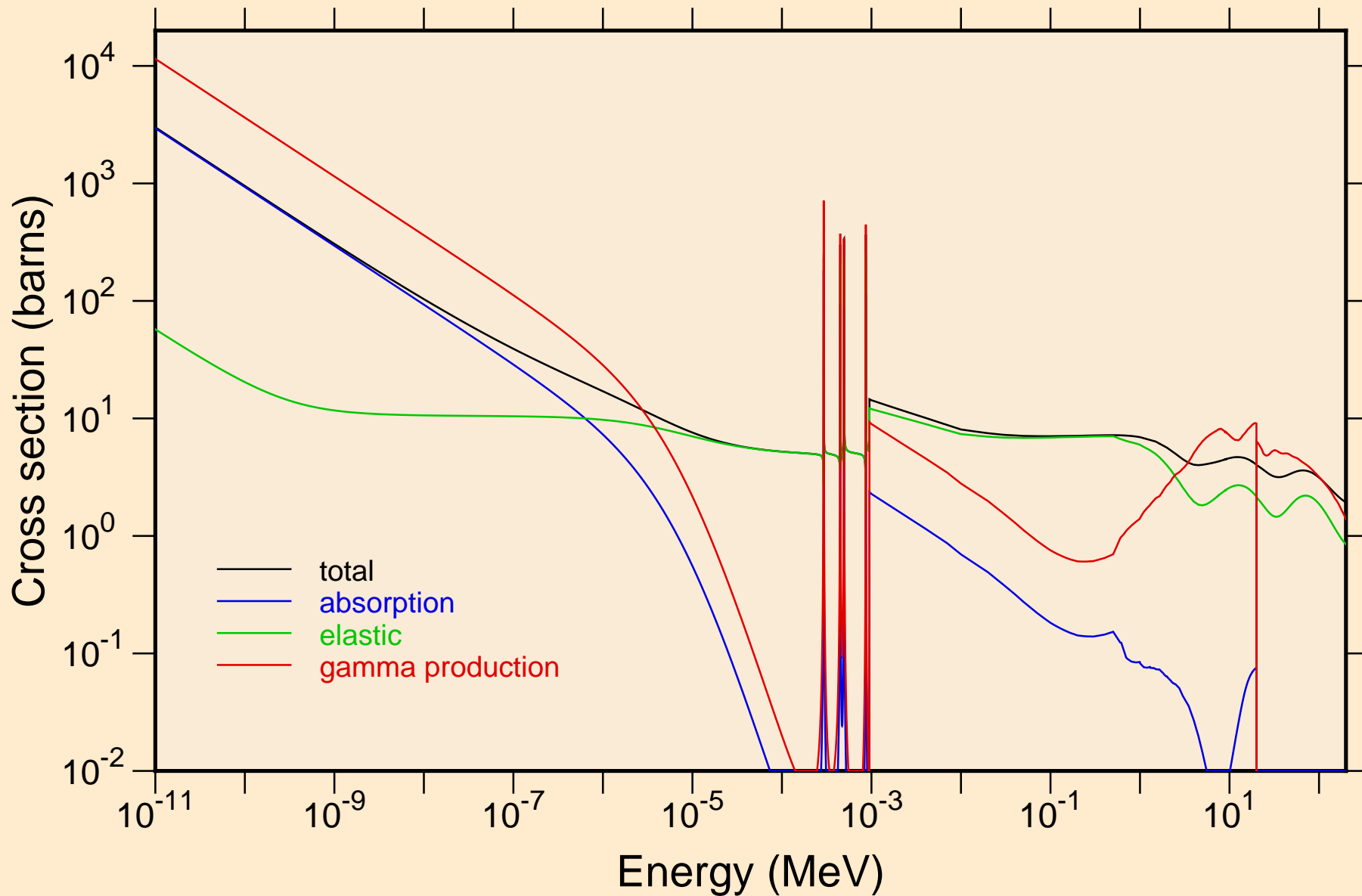

50-SN-115 FOR FENDL-3.1 FROM FENDL-3.1 WITH NJOY2012.50  
resonance total cross section

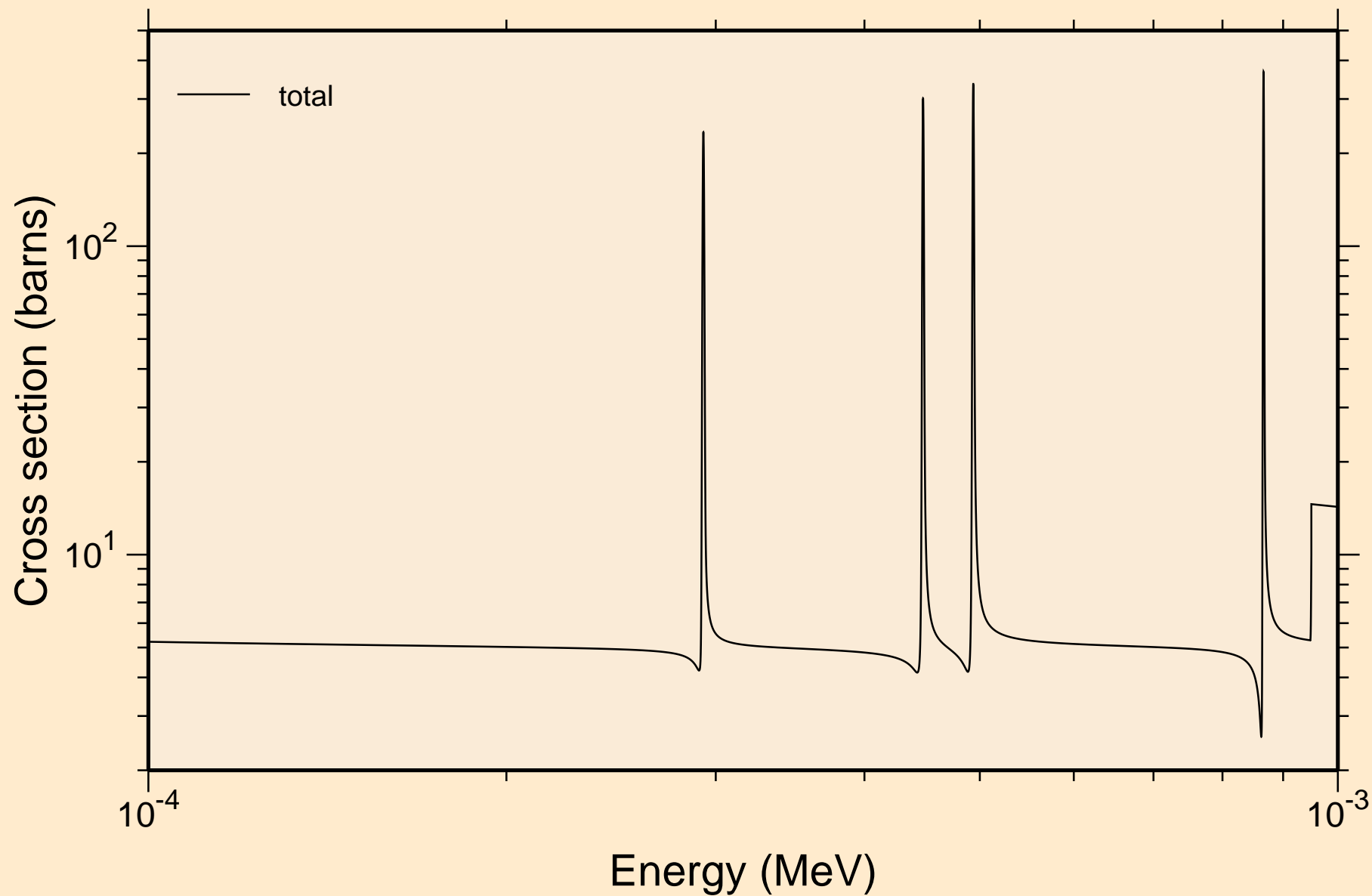

50-SN-115 FOR FENDL-3.1 FROM FENDL-3.1 WITH NJOY2012.50  
resonance total cross section

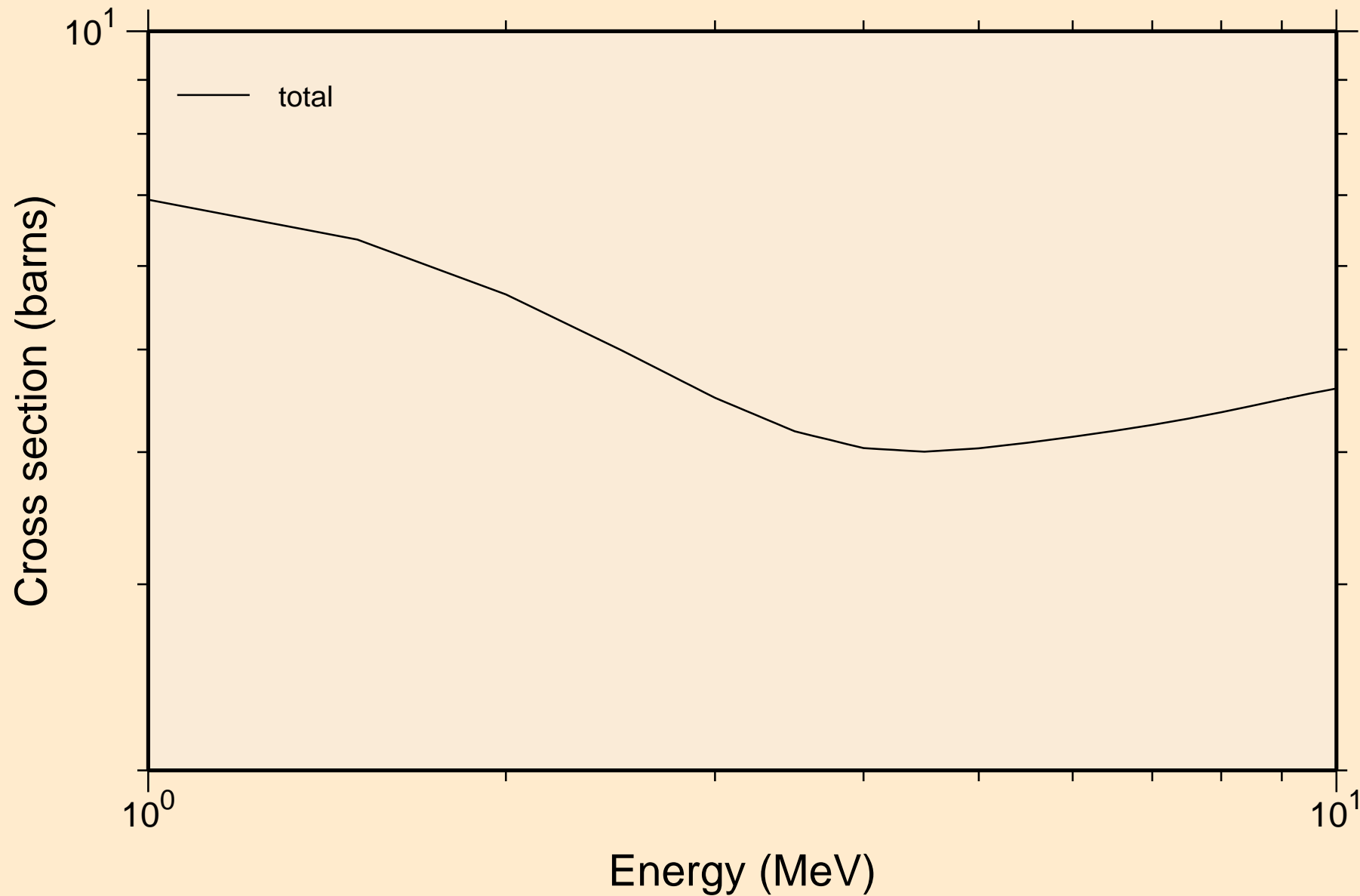

50-SN-115 FOR FENDL-3.1 FROM FENDL-3.1 WITH NJOY2012.50  
resonance absorption cross sections

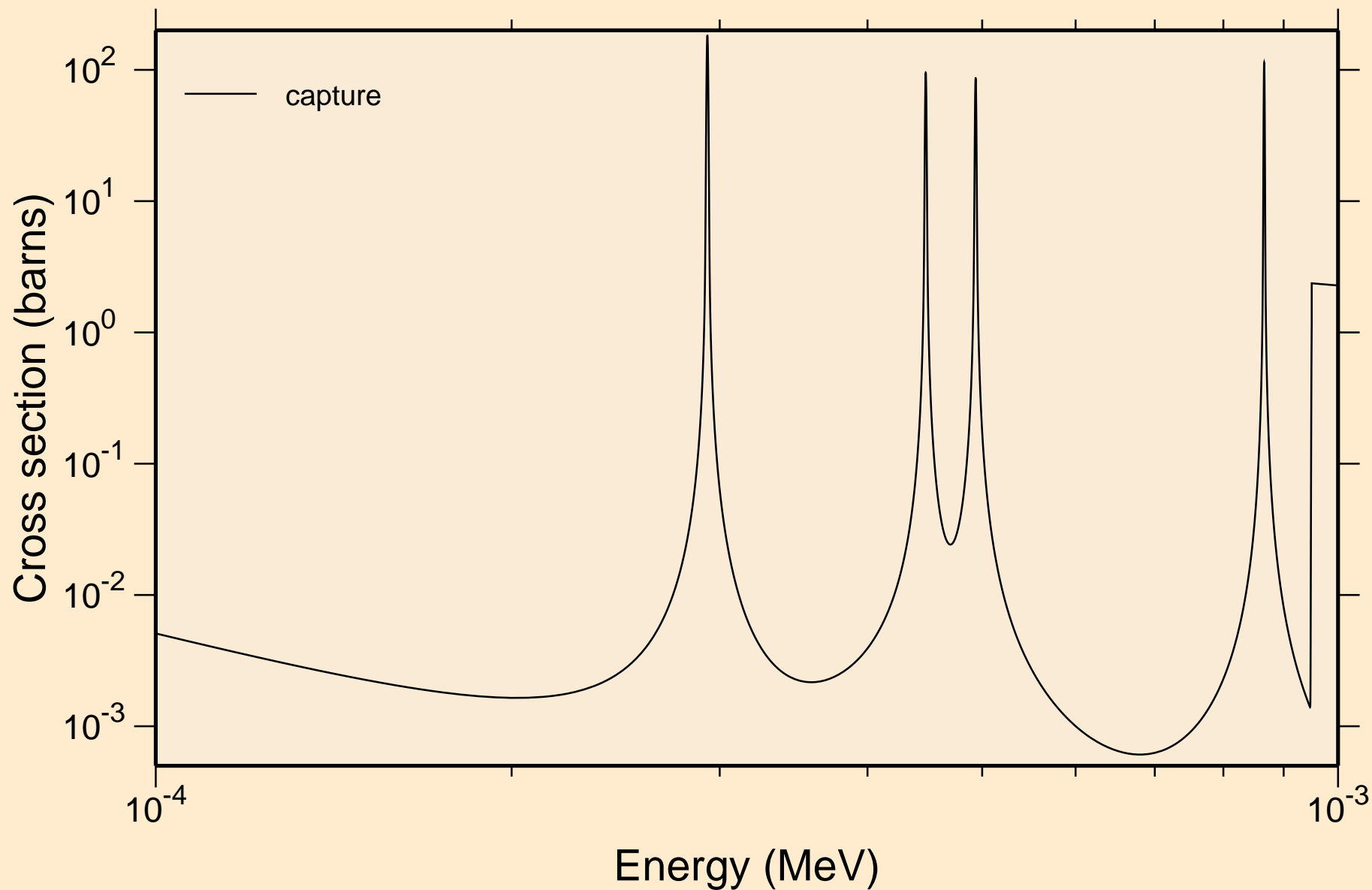

50-SN-115 FOR FENDL-3.1 FROM FENDL-3.1 WITH NJOY2012.50  
resonance absorption cross sections

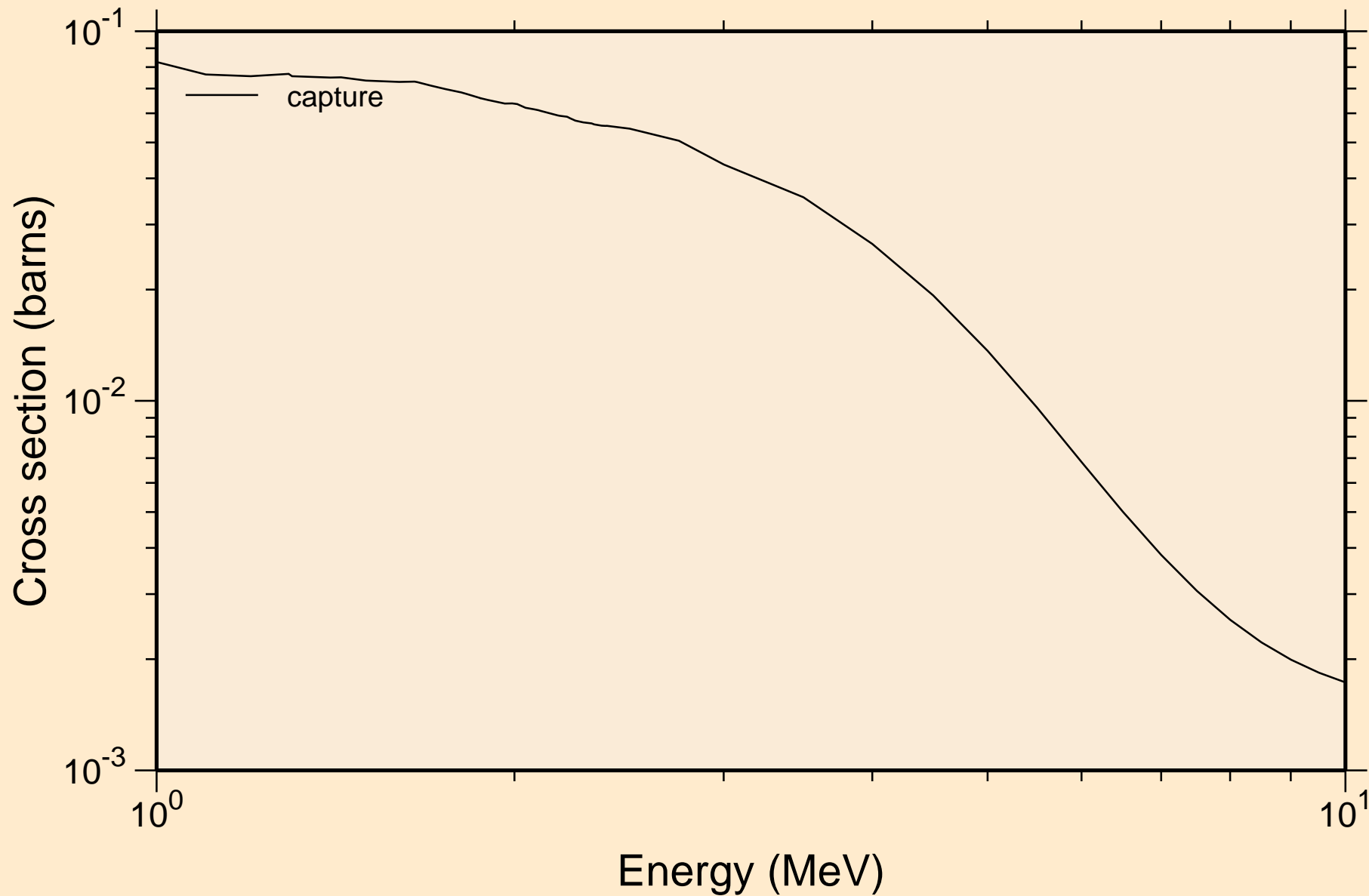

50-SN-115 FOR FENDL-3.1 FROM FENDL-3.1 WITH NJOY2012.50  
UR total cross section

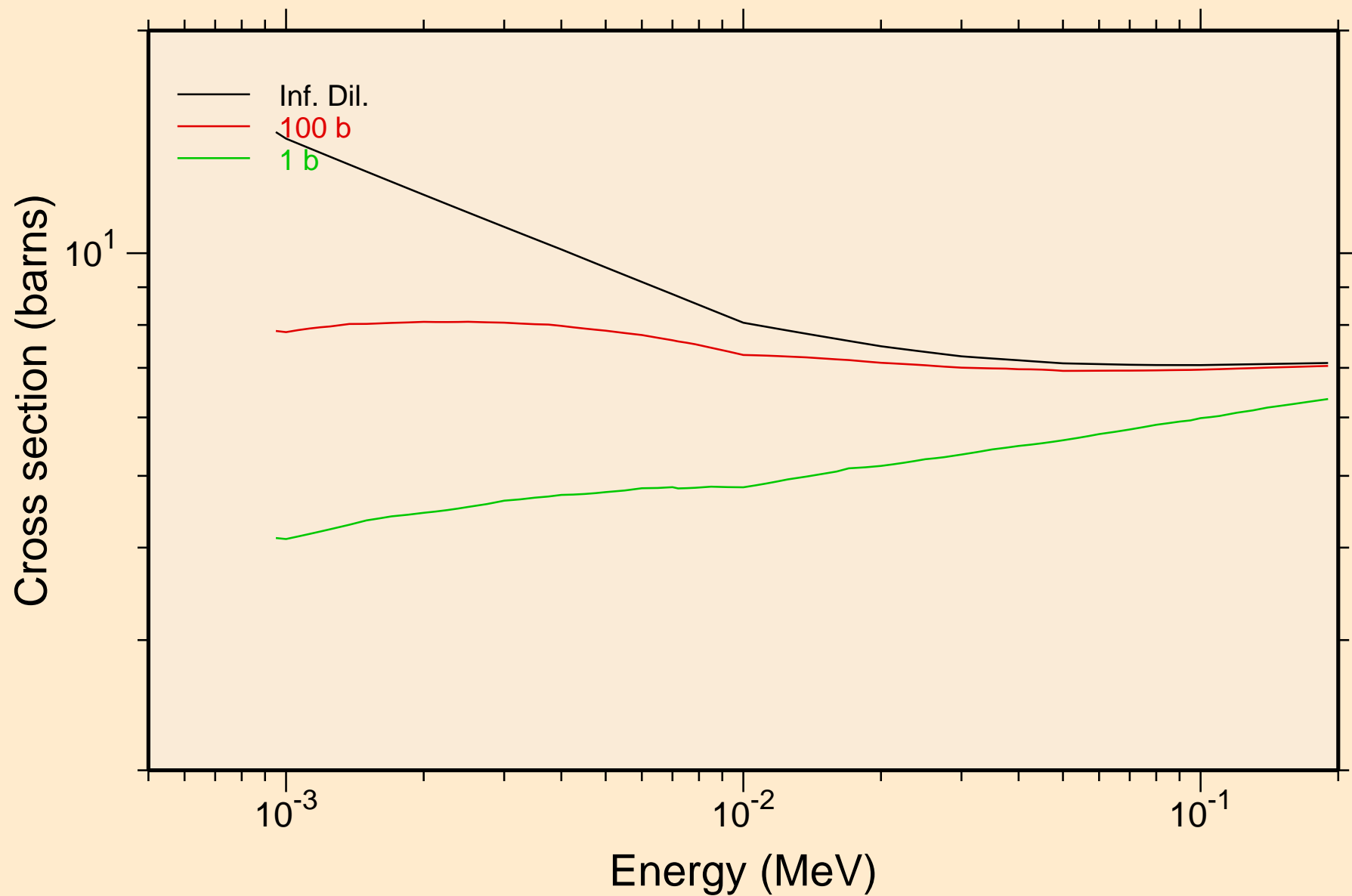

50-SN-115 FOR FENDL-3.1 FROM FENDL-3.1 WITH NJOY2012.50  
UR elastic cross section

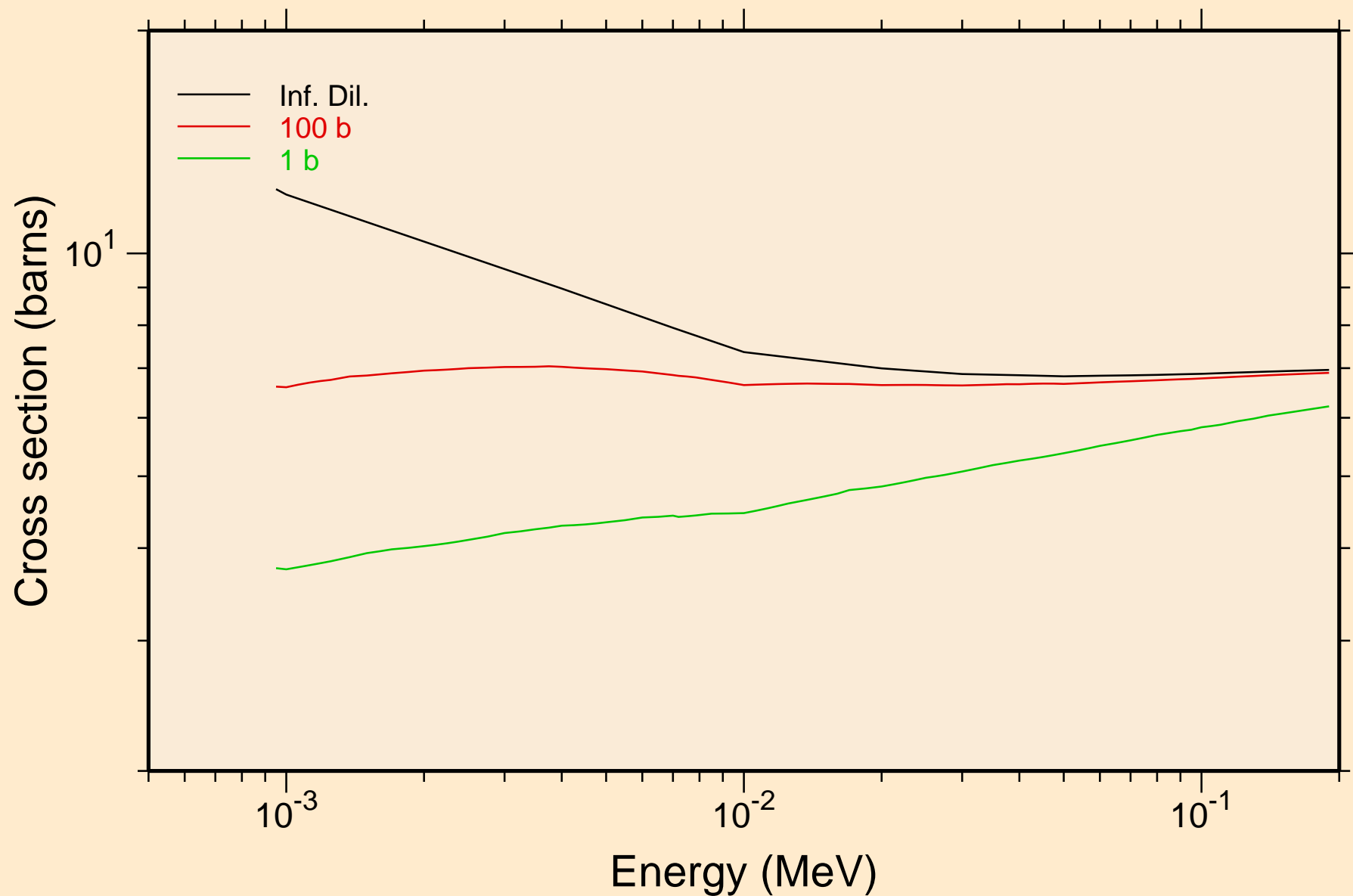

50-SN-115 FOR FENDL-3.1 FROM FENDL-3.1 WITH NJOY2012.50  
UR capture cross section

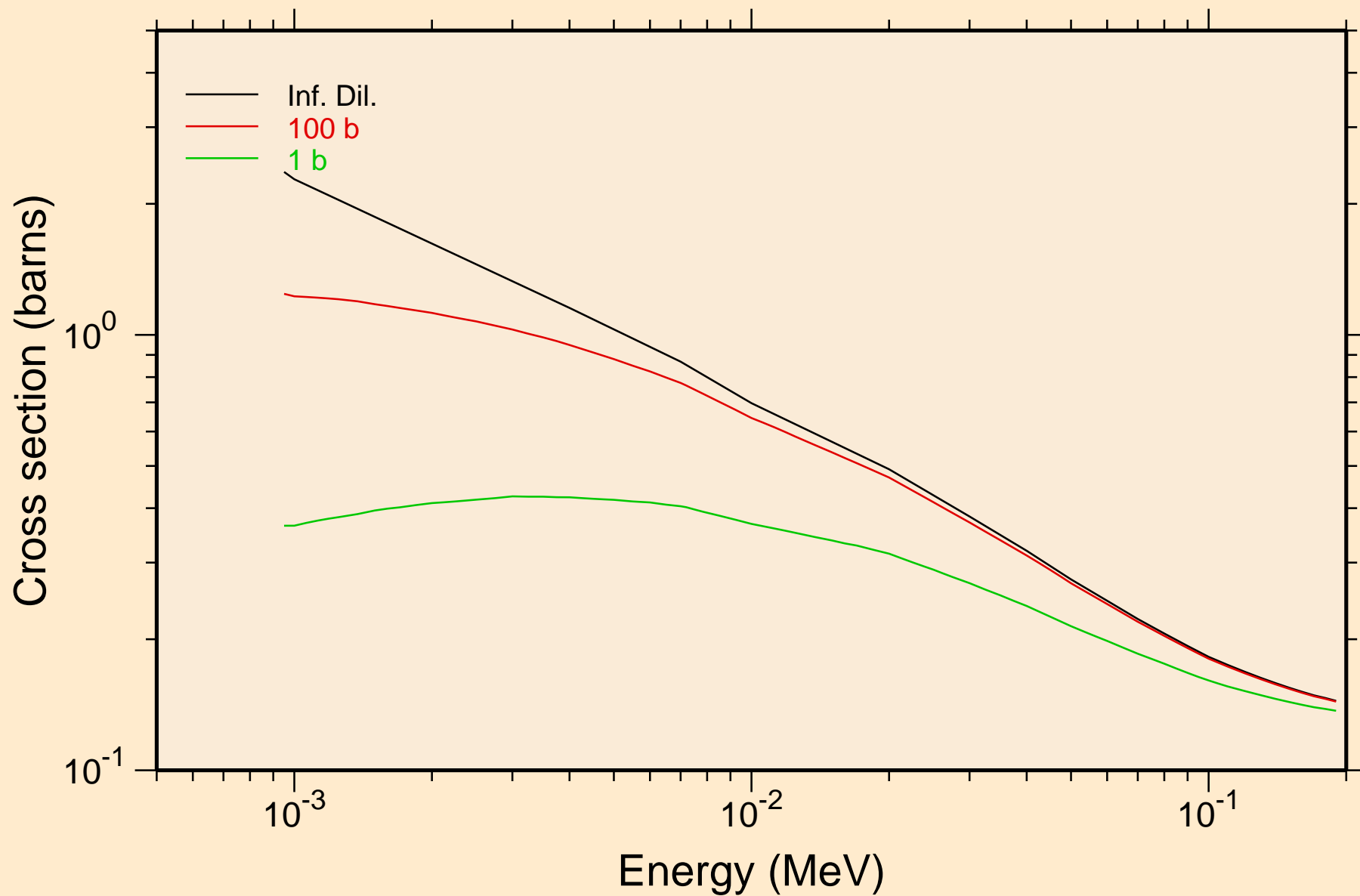



# 50-SN-115 FOR FENDL-3.1 FROM FENDL-3.1 WITH NJOY2012.50 Heating

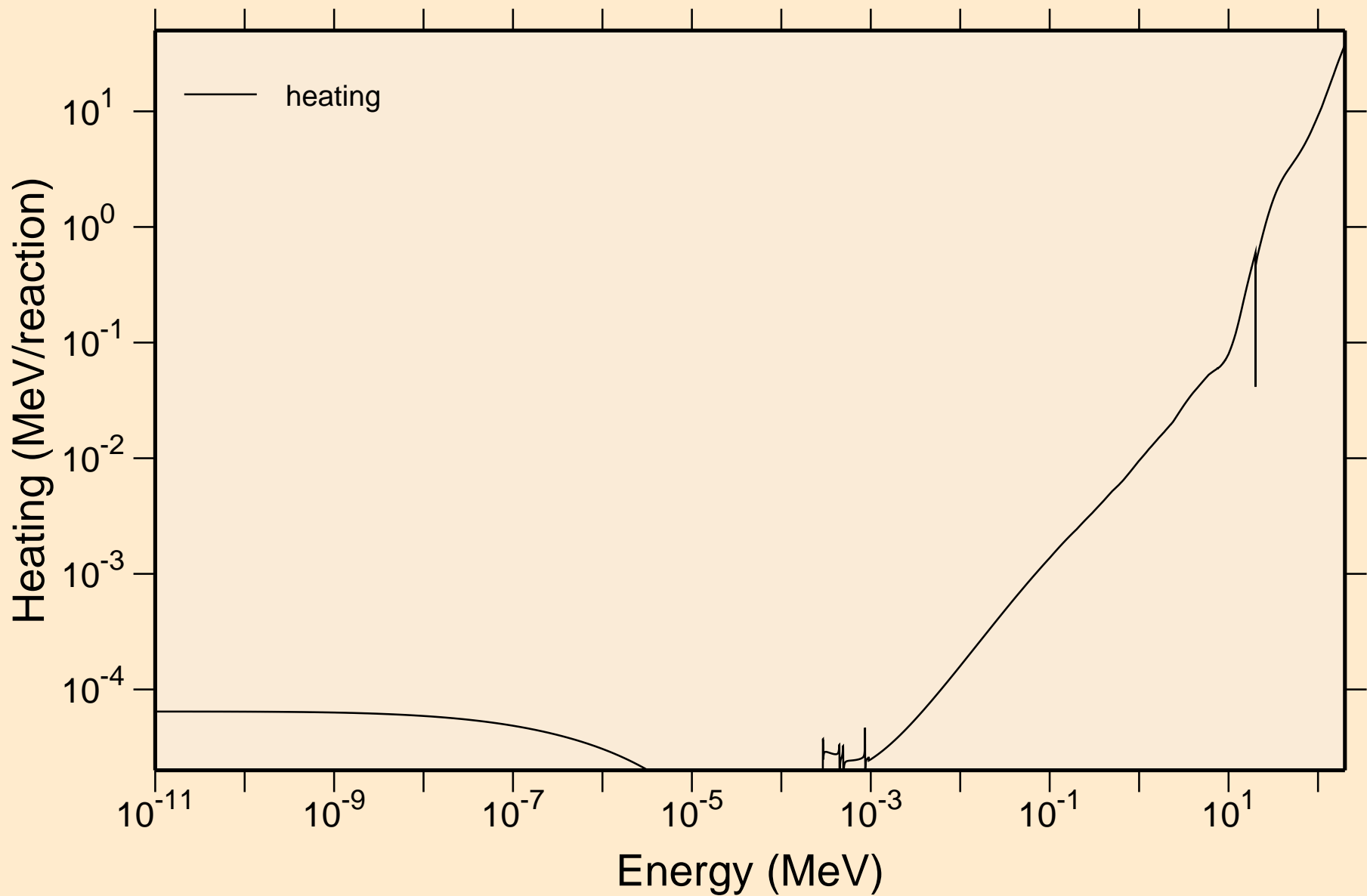

# 50-SN-115 FOR FENDL-3.1 FROM FENDL-3.1 WITH NJOY2012.50 Damage

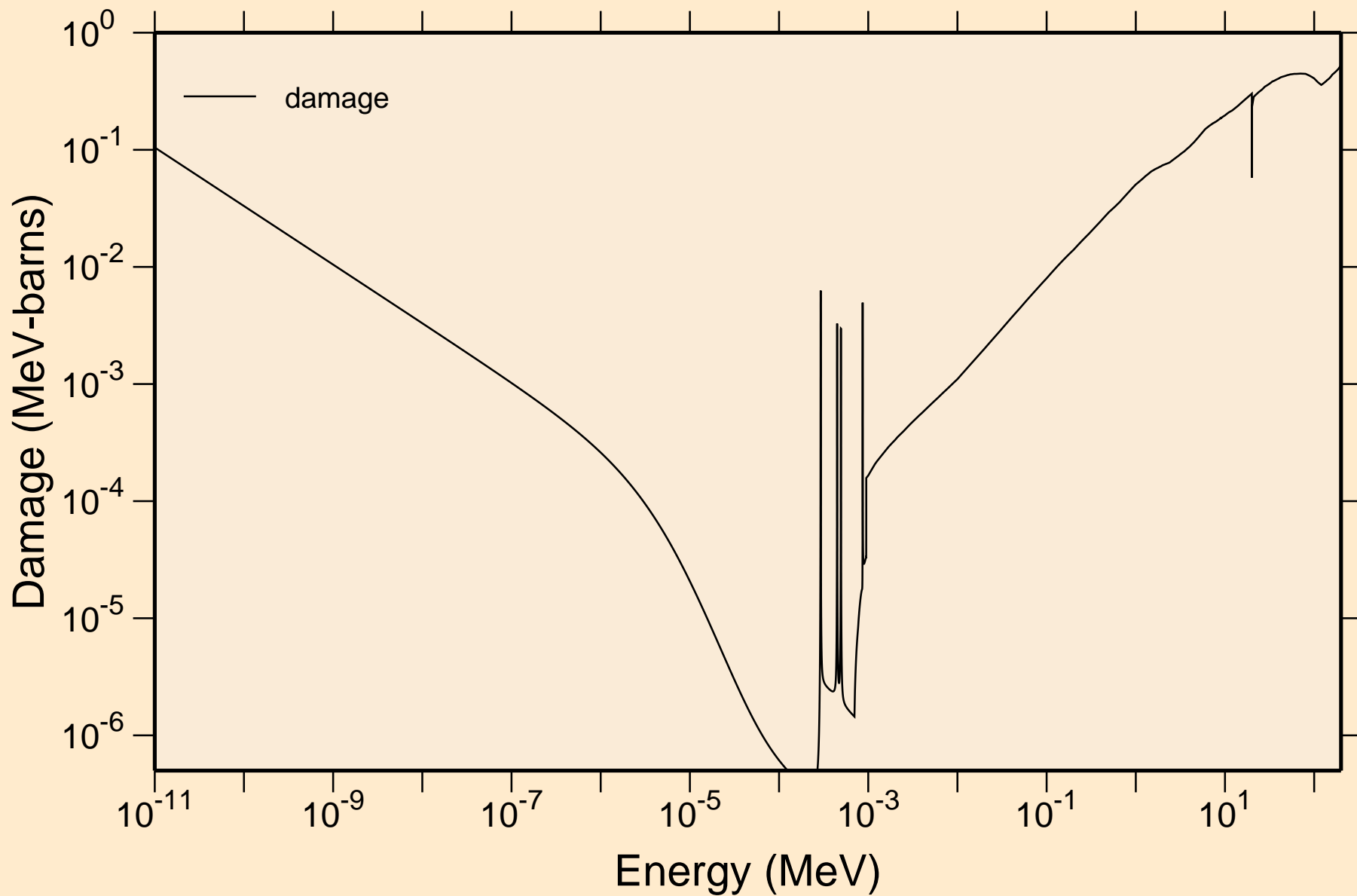

# 50-SN-115 FOR FENDL-3.1 FROM FENDL-3.1 WITH NJOY2012.50

## Non-threshold reactions

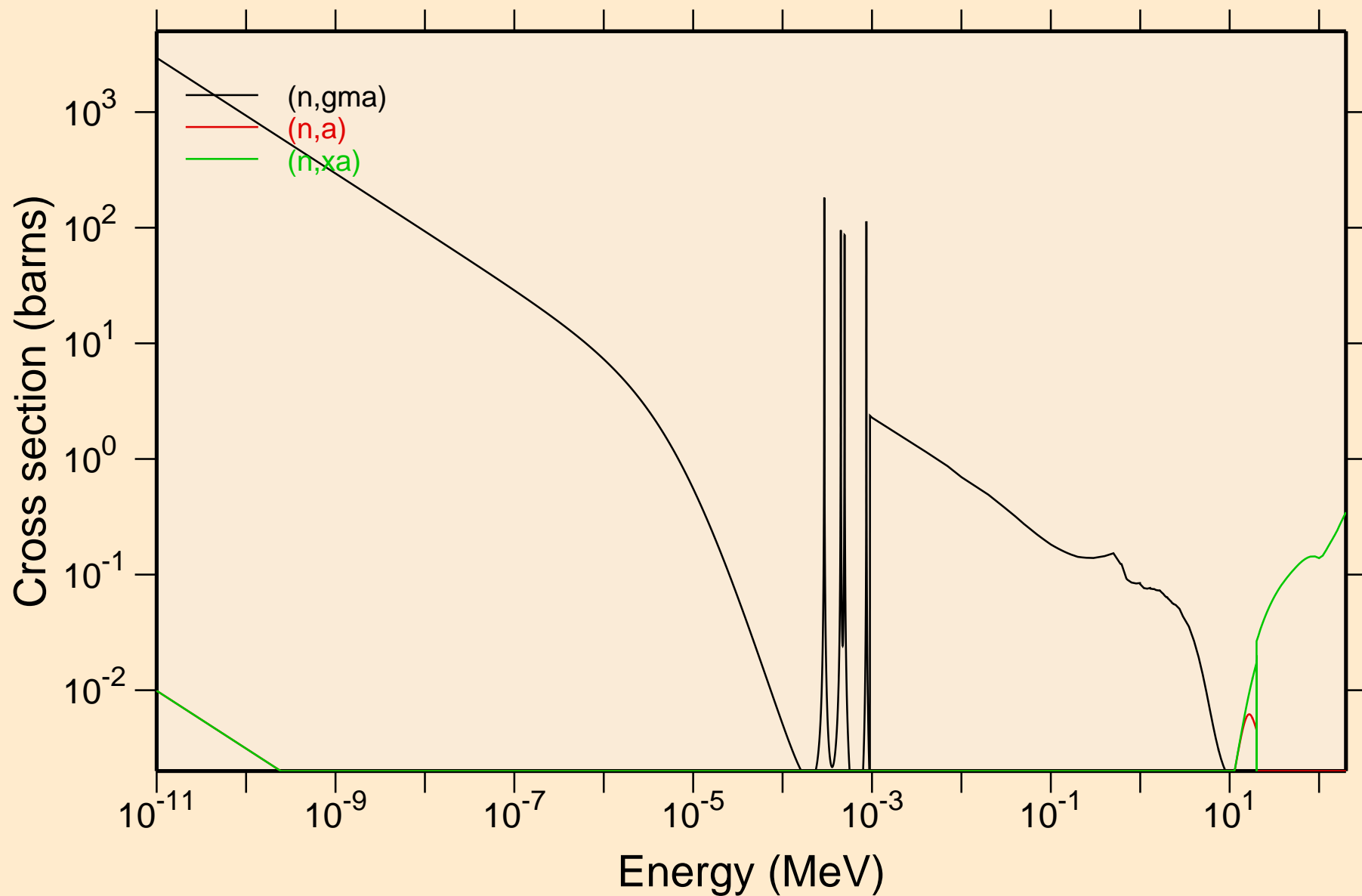

50-SN-115 FOR FENDL-3.1 FROM FENDL-3.1 WITH NJOY2012.50

### Principal cross sections

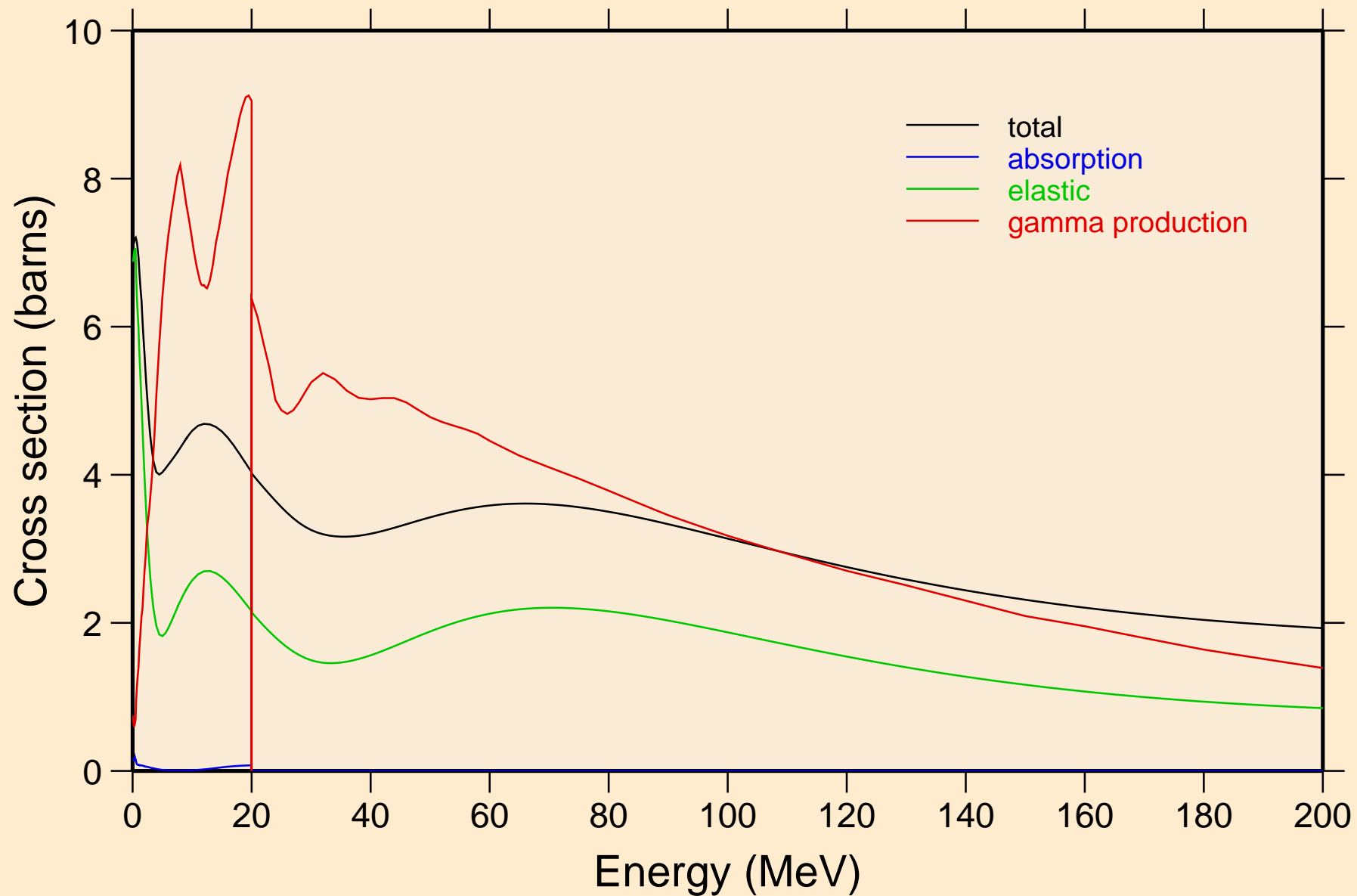

# 50-SN-115 FOR FENDL-3.1 FROM FENDL-3.1 WITH NJOY2012.50 Heating

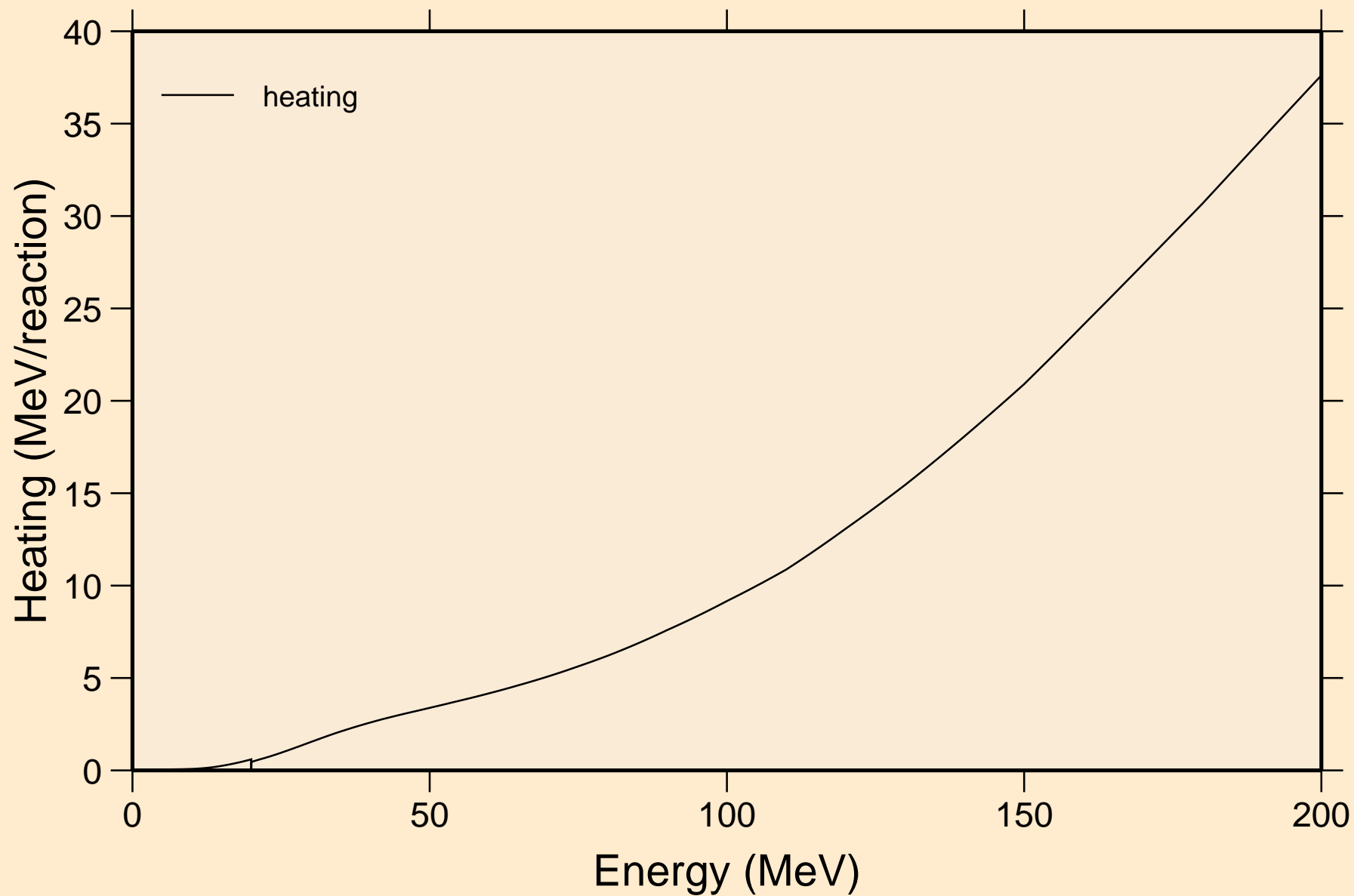

# 50-SN-115 FOR FENDL-3.1 FROM FENDL-3.1 WITH NJOY2012.50 Damage

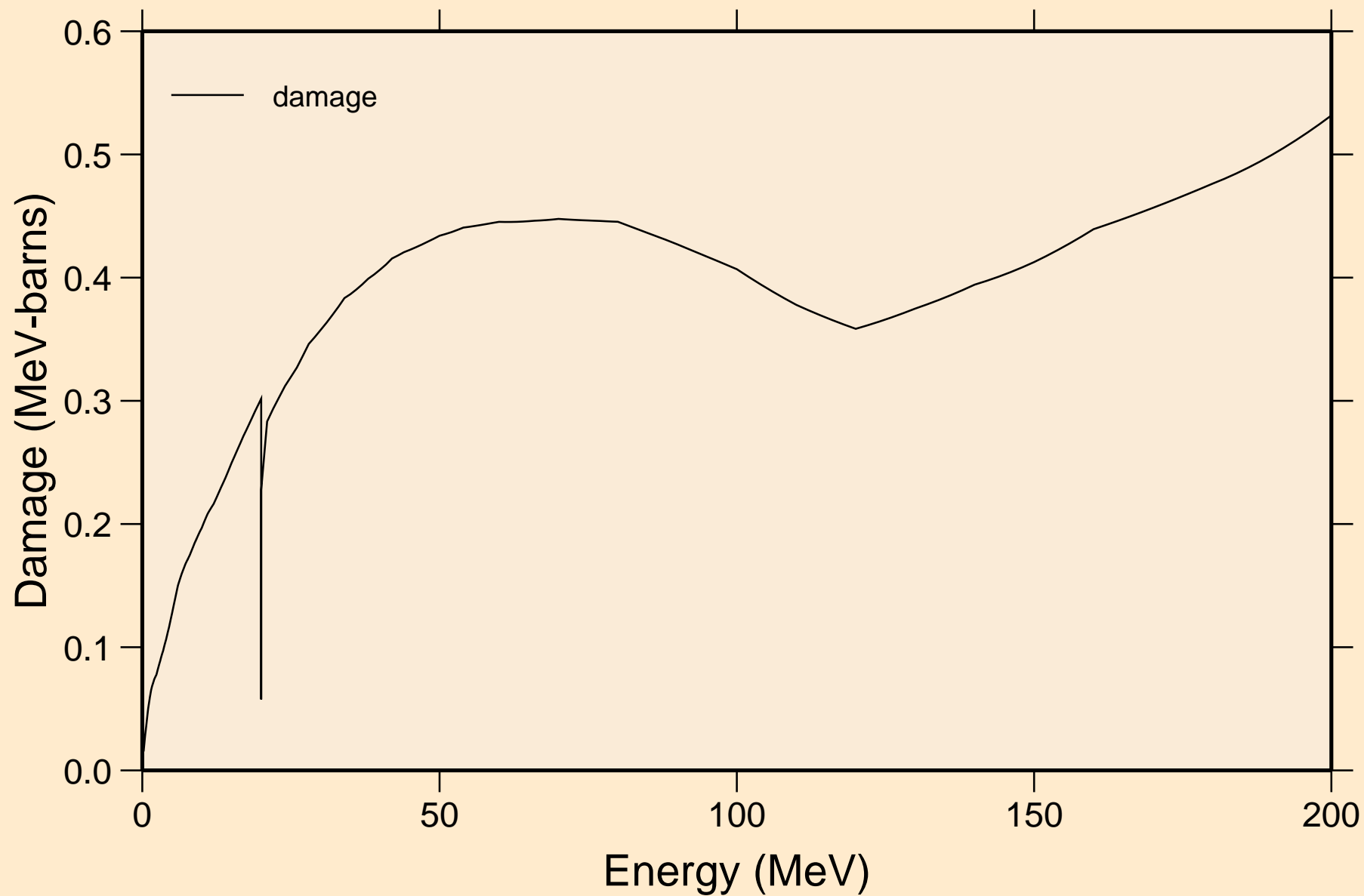

50-SN-115 FOR FENDL-3.1 FROM FENDL-3.1 WITH NJOY2012.50  
Non-threshold reactions

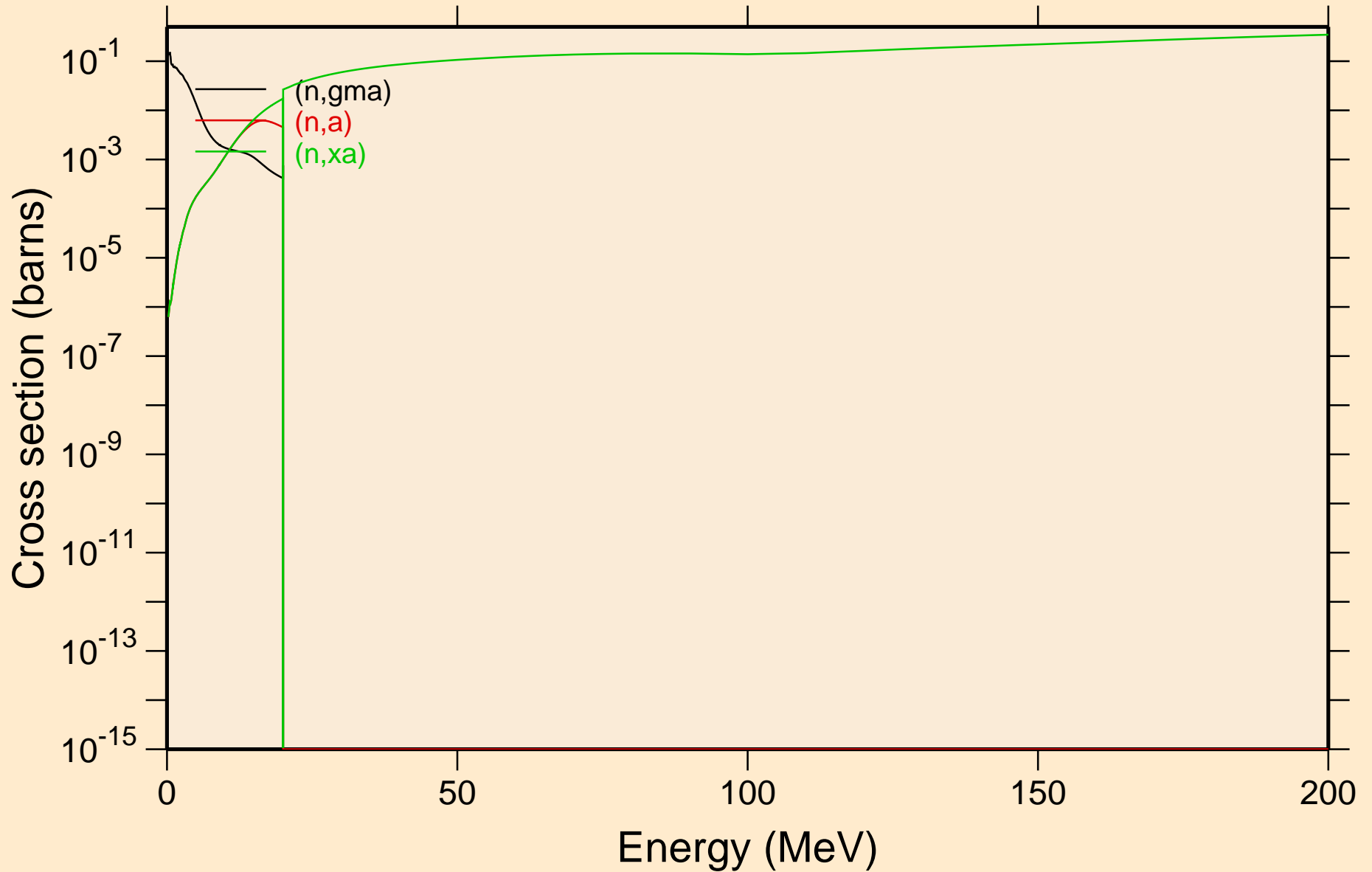

# 50-SN-115 FOR FENDL-3.1 FROM FENDL-3.1 WITH NJOY2012.50

## Inelastic levels

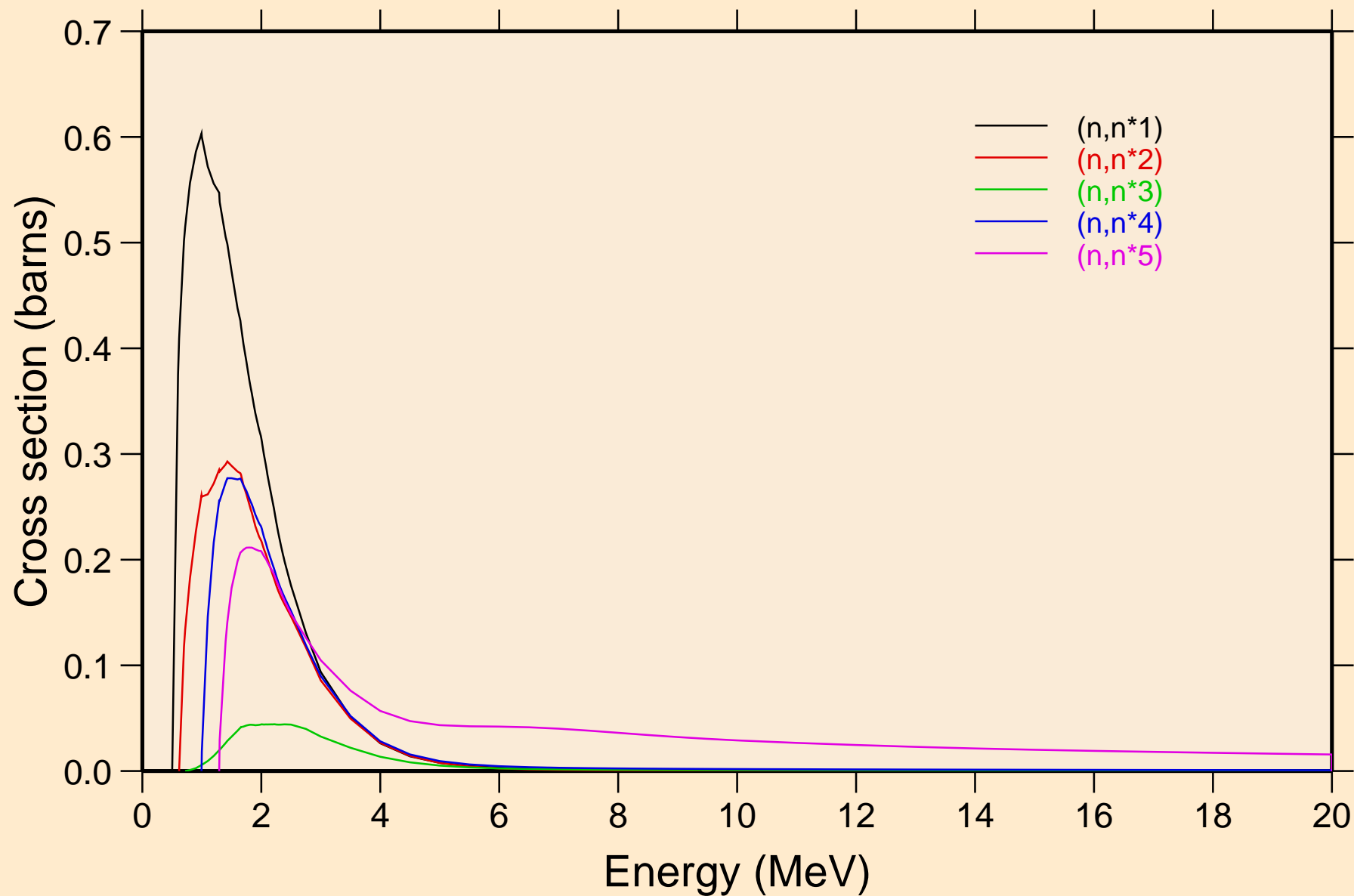



# 50-SN-115 FOR FENDL-3.1 FROM FENDL-3.1 WITH NJOY2012.50

## Inelastic levels

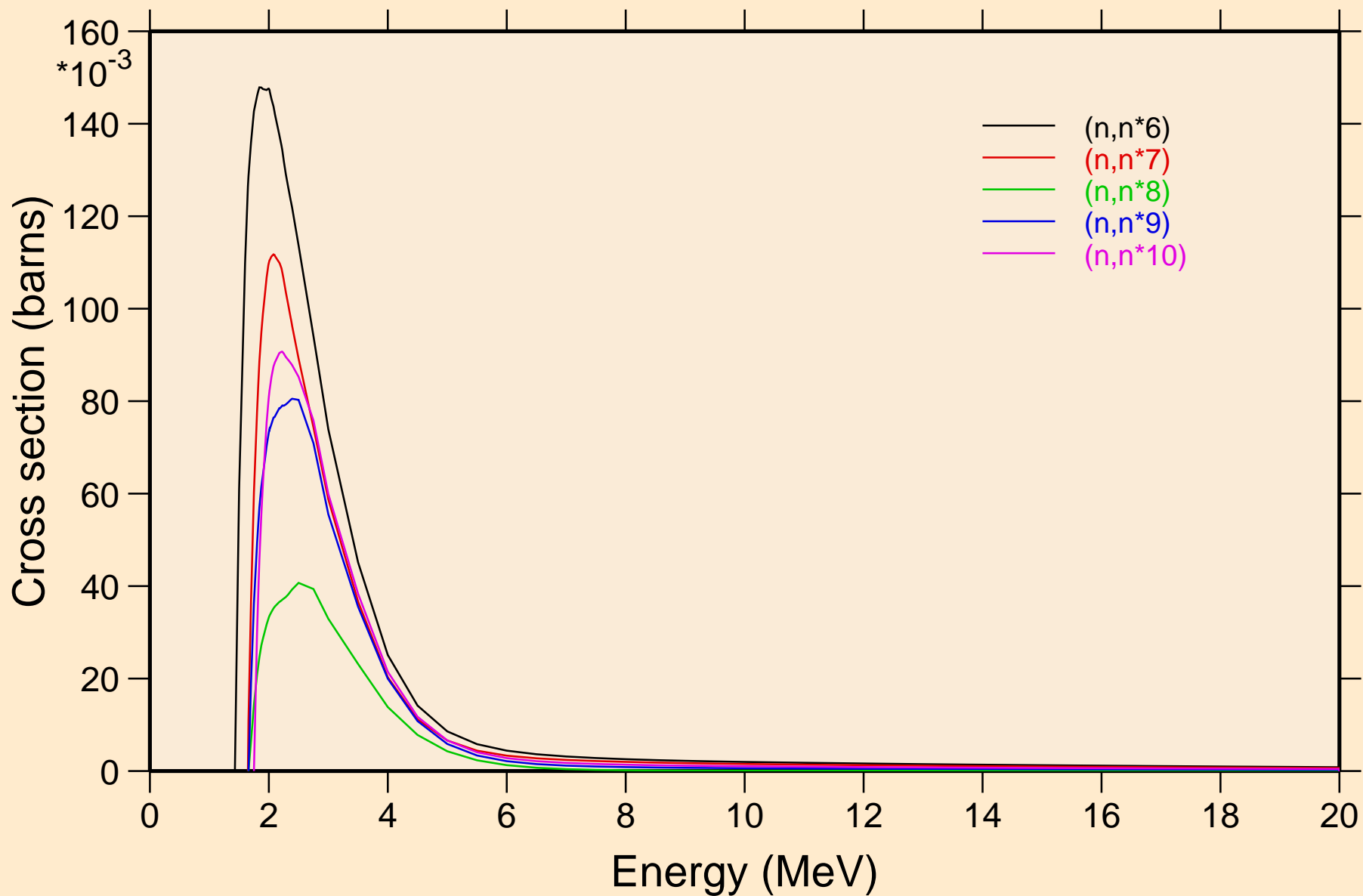

# 50-SN-115 FOR FENDL-3.1 FROM FENDL-3.1 WITH NJOY2012.50

## Inelastic levels

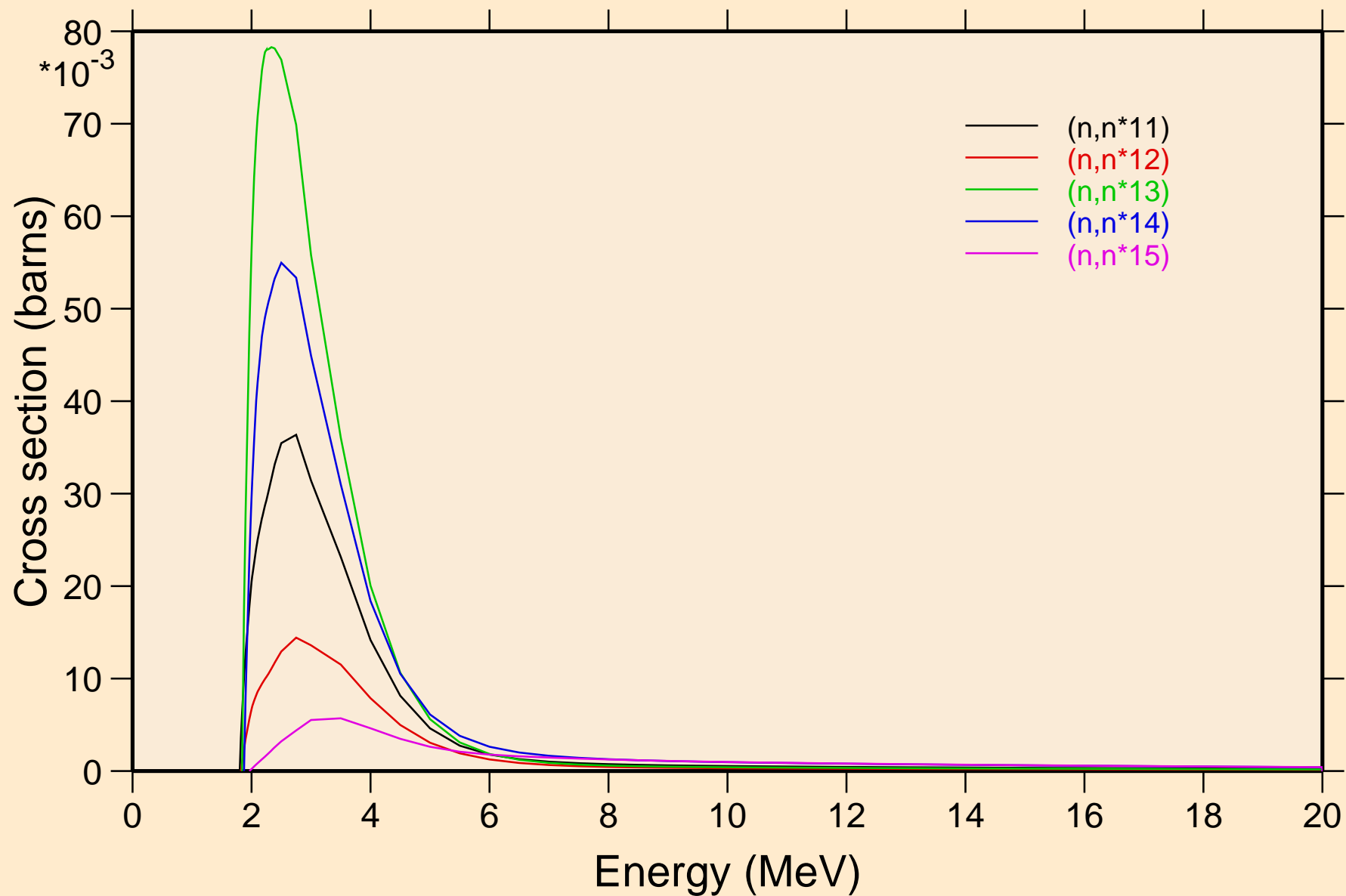

# 50-SN-115 FOR FENDL-3.1 FROM FENDL-3.1 WITH NJOY2012.50

## Inelastic levels

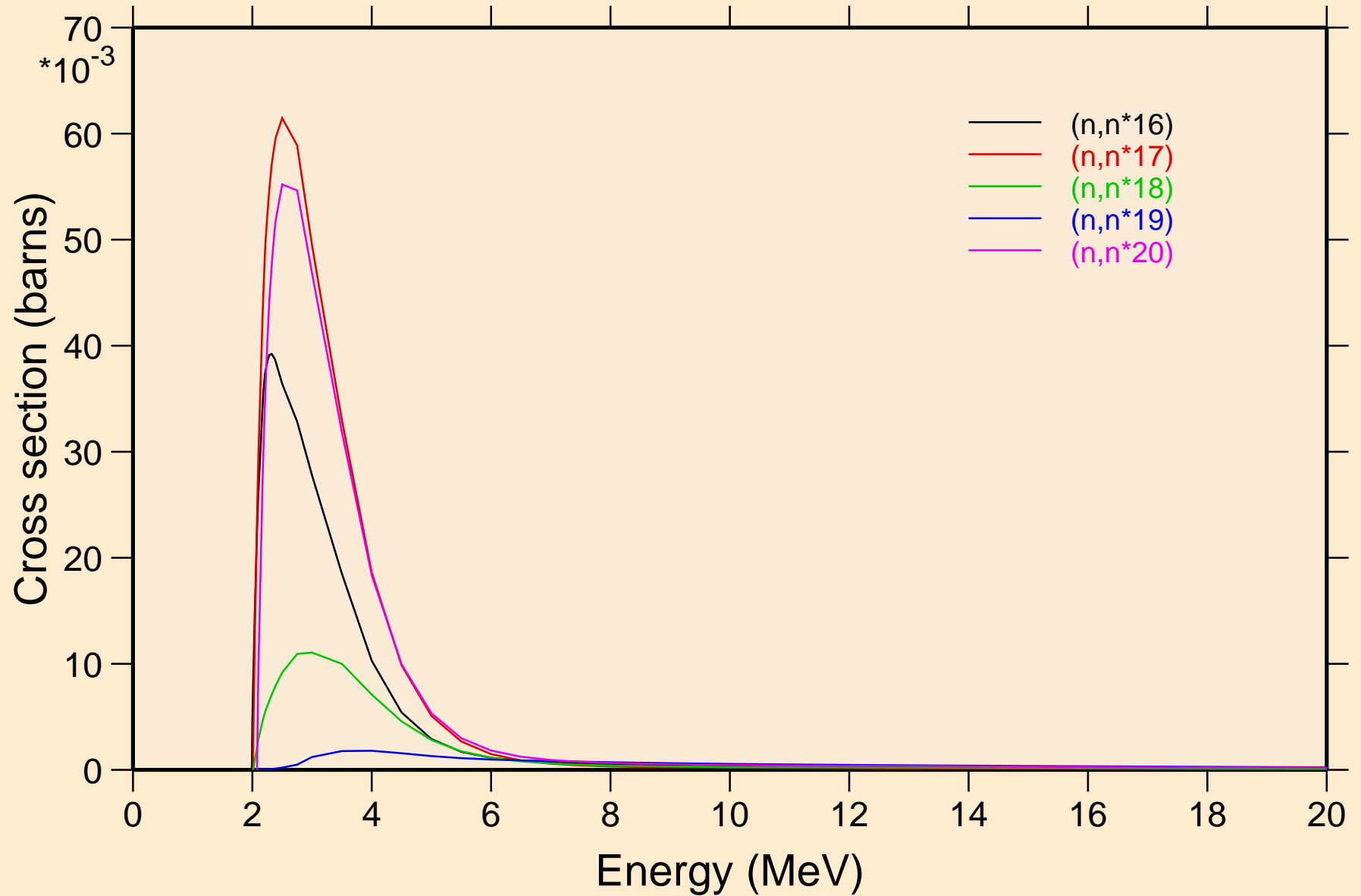

50-SN-115 FOR FENDL-3.1 FROM FENDL-3.1 WITH NJOY2012.50  
Inelastic levels

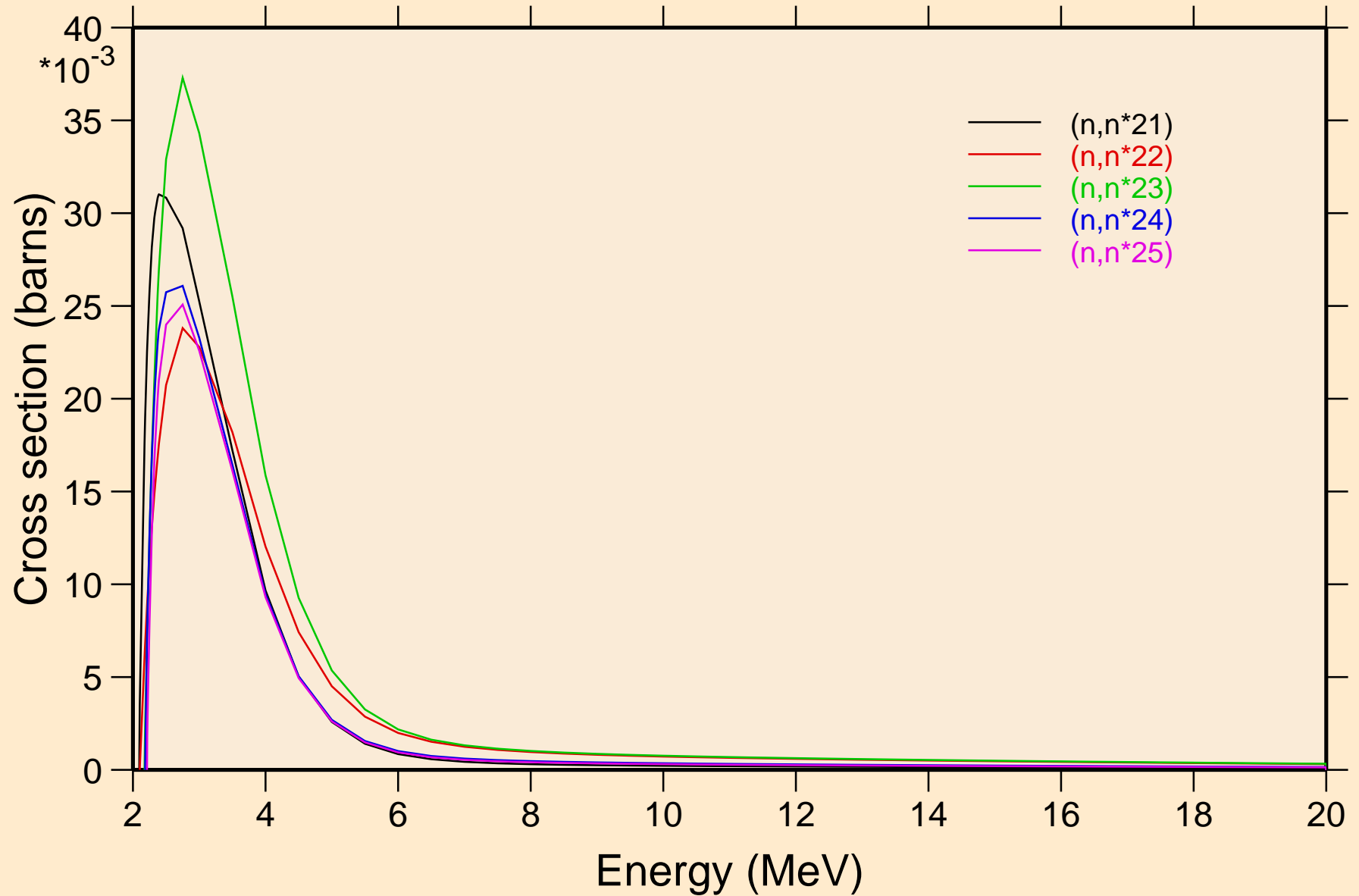

50-SN-115 FOR FENDL-3.1 FROM FENDL-3.1 WITH NJOY2012.50  
Inelastic levels

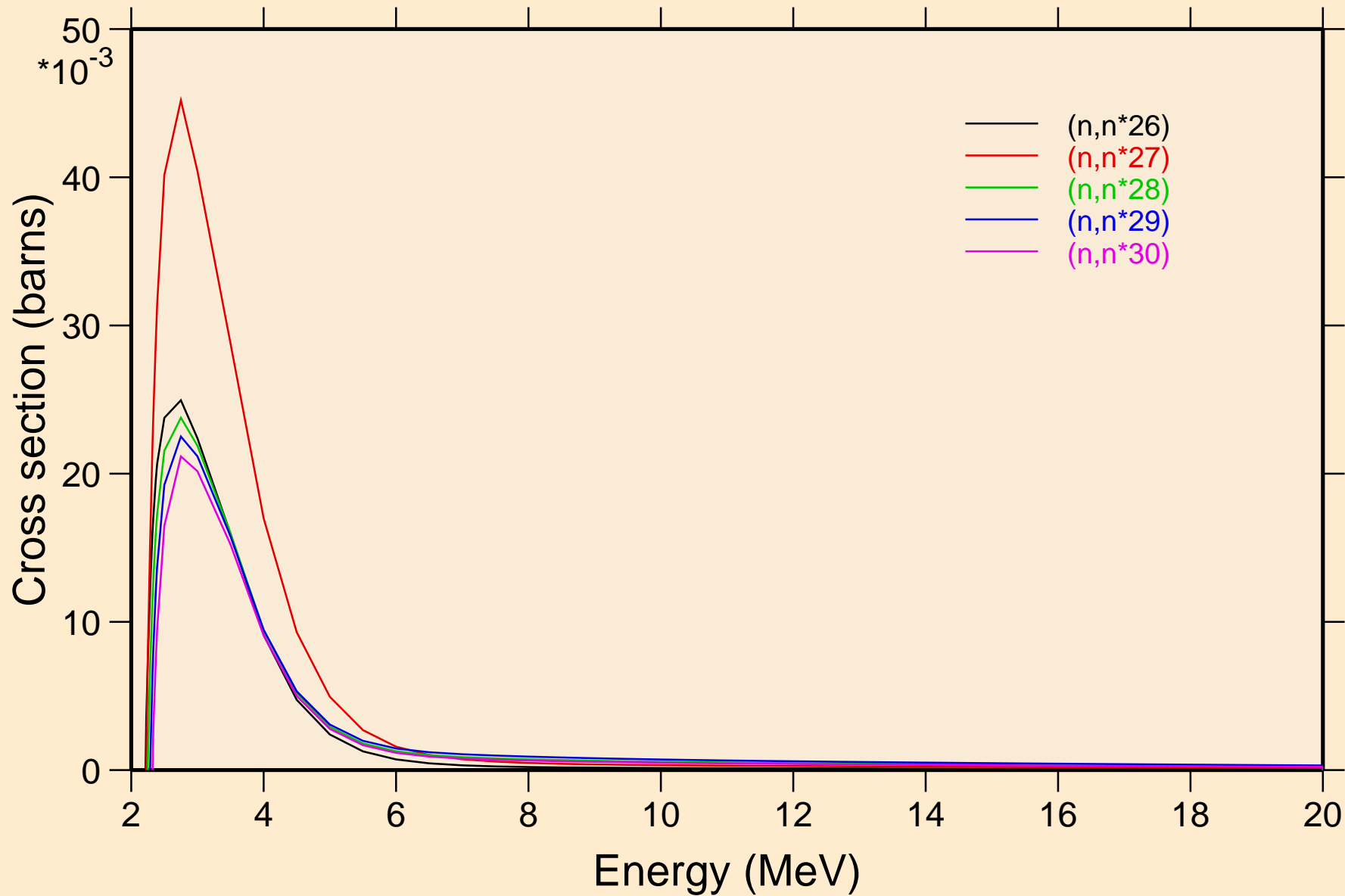

50-SN-115 FOR FENDL-3.1 FROM FENDL-3.1 WITH NJOY2012.50  
Inelastic levels

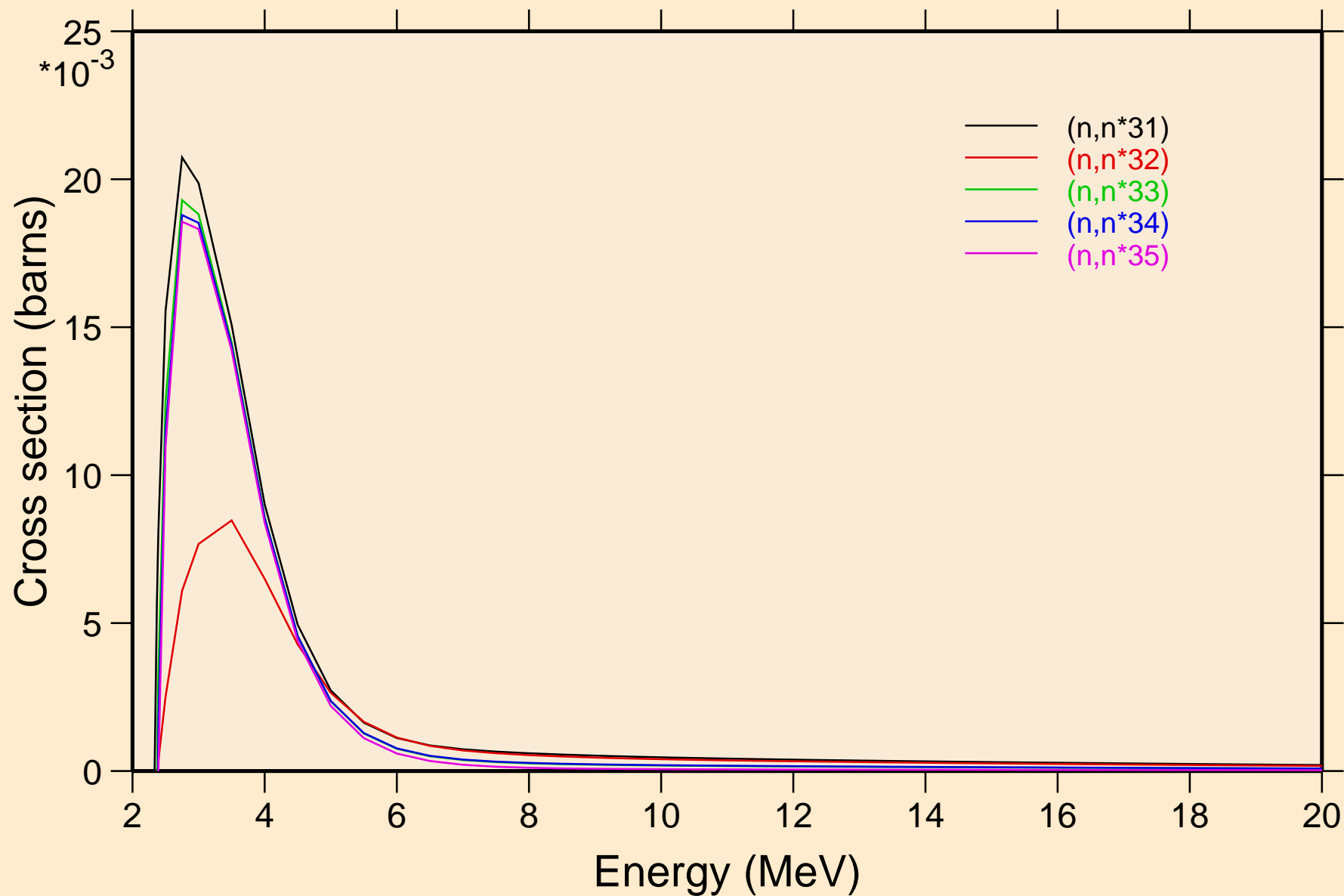

50-SN-115 FOR FENDL-3.1 FROM FENDL-3.1 WITH NJOY2012.50  
Threshold reactions

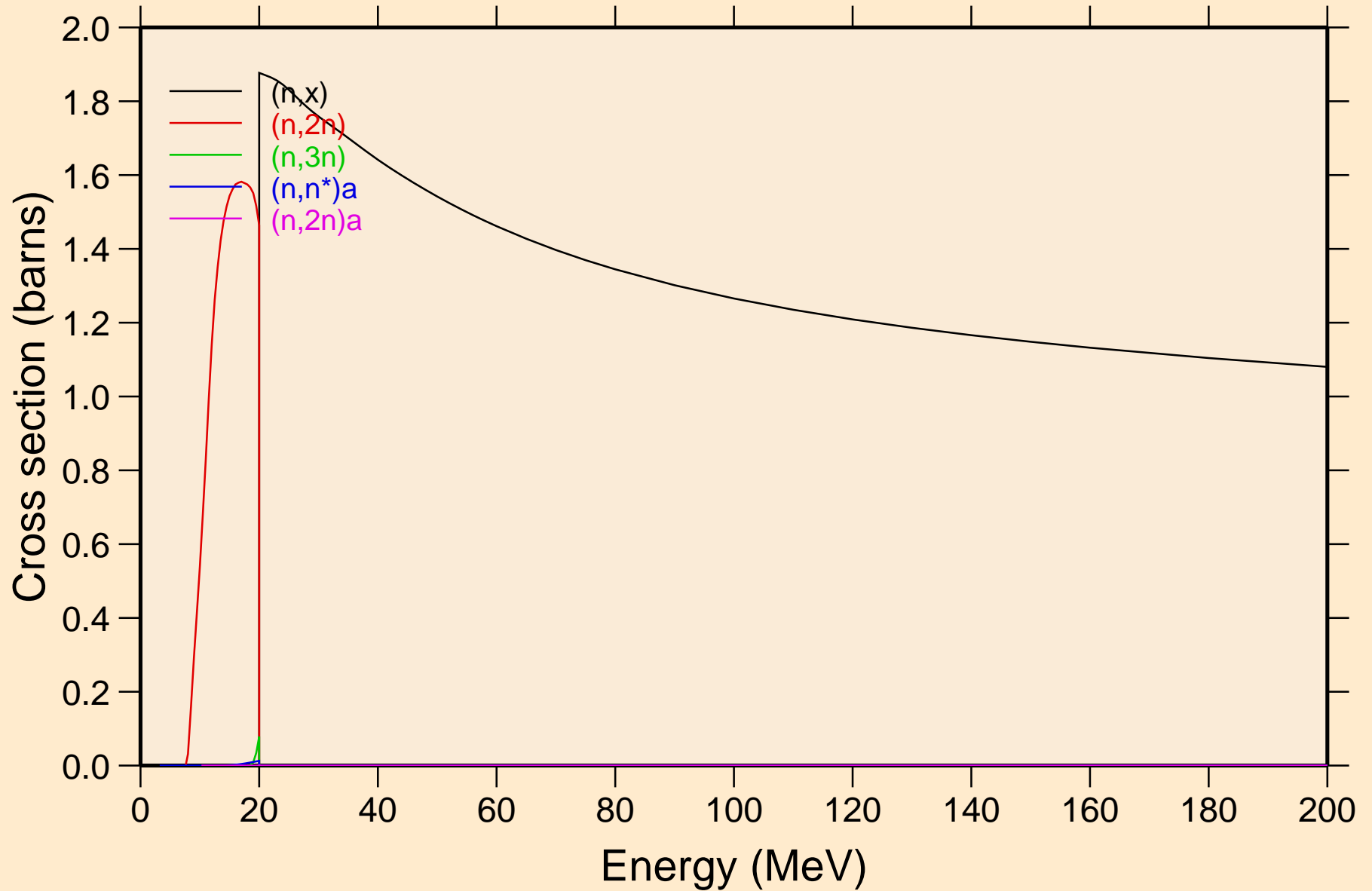

50-SN-115 FOR FENDL-3.1 FROM FENDL-3.1 WITH NJOY2012.50  
Threshold reactions

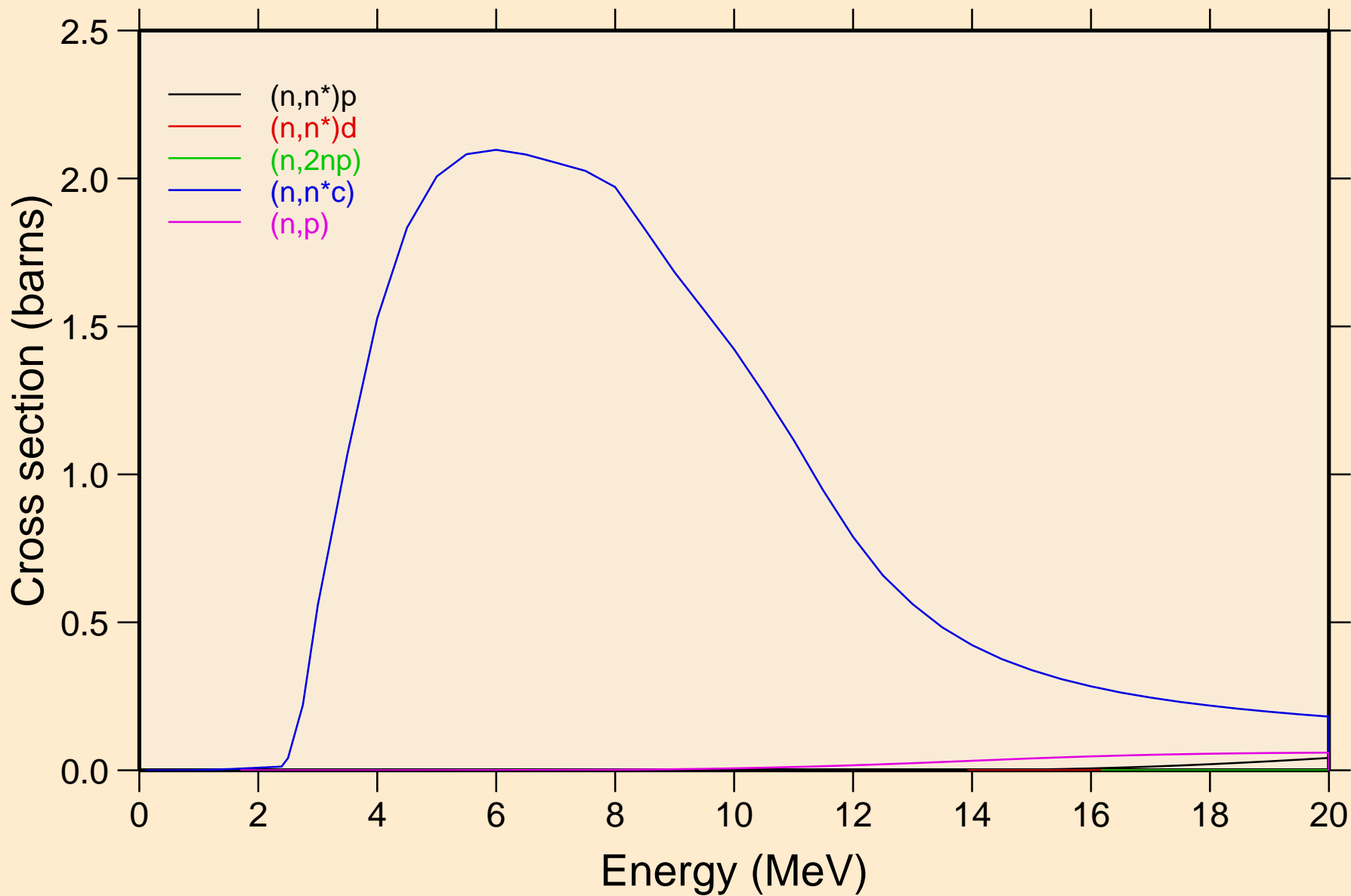



50-SN-115 FOR FENDL-3.1 FROM FENDL-3.1 WITH NJOY2012.50  
Threshold reactions

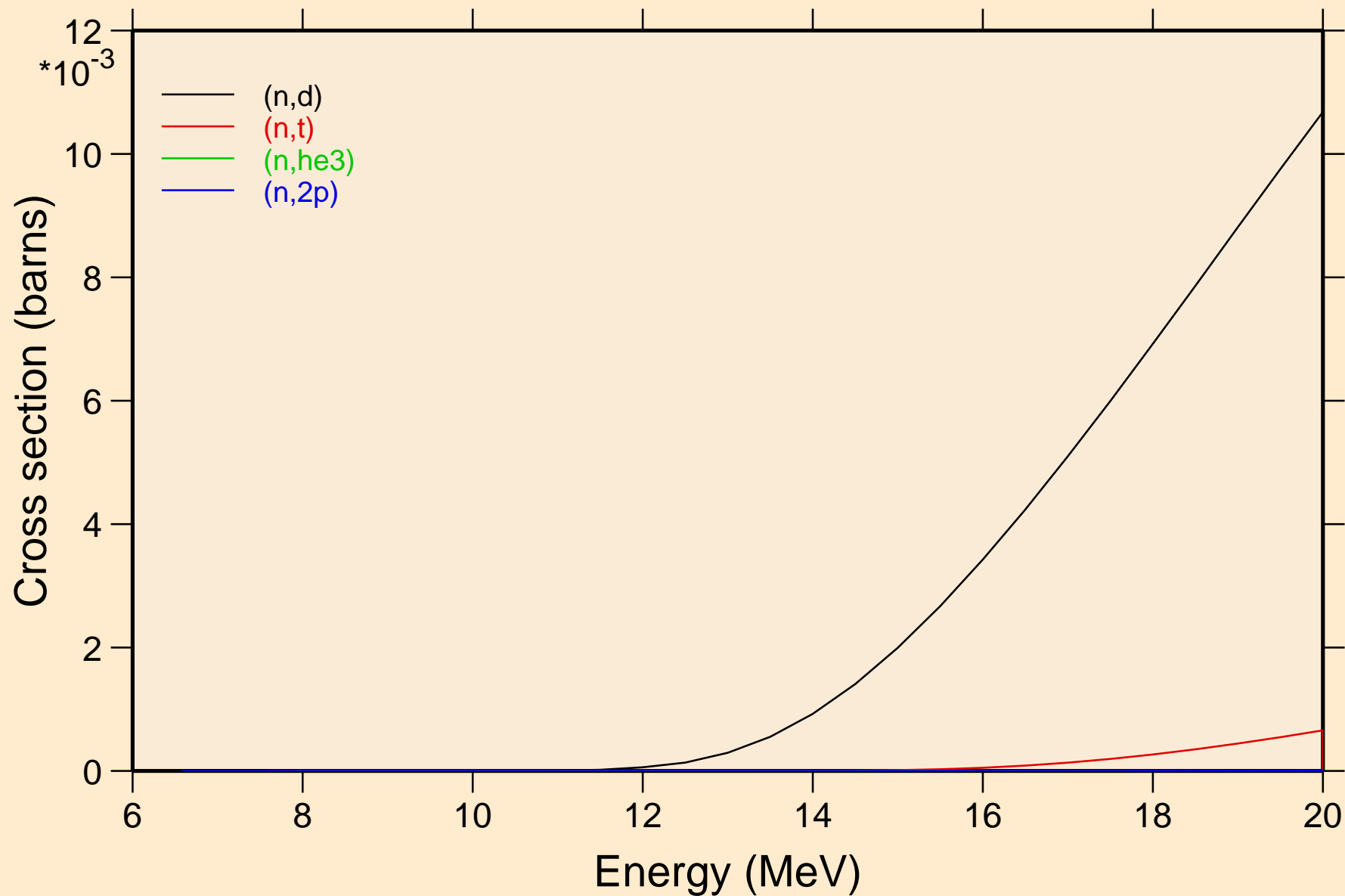

# 50-SN-115 FOR FENDL-3.1 FROM FENDL-3.1 WITH NJOY2012.50

## Threshold reactions

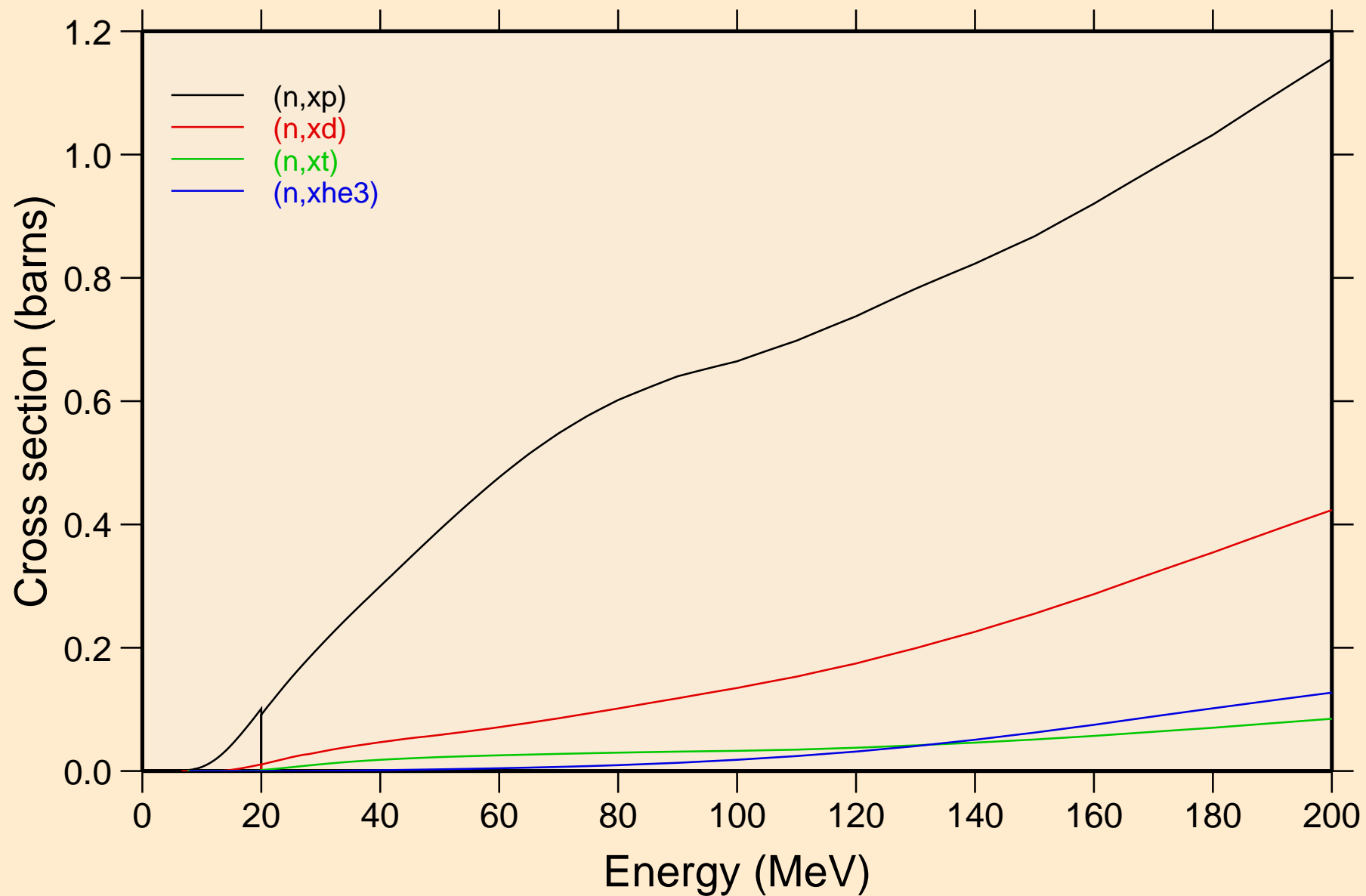

50-SN-115 FOR FENDL-3.1 FROM FENDL-3.1 WITH NJOY2012.50  
angular distribution for elastic

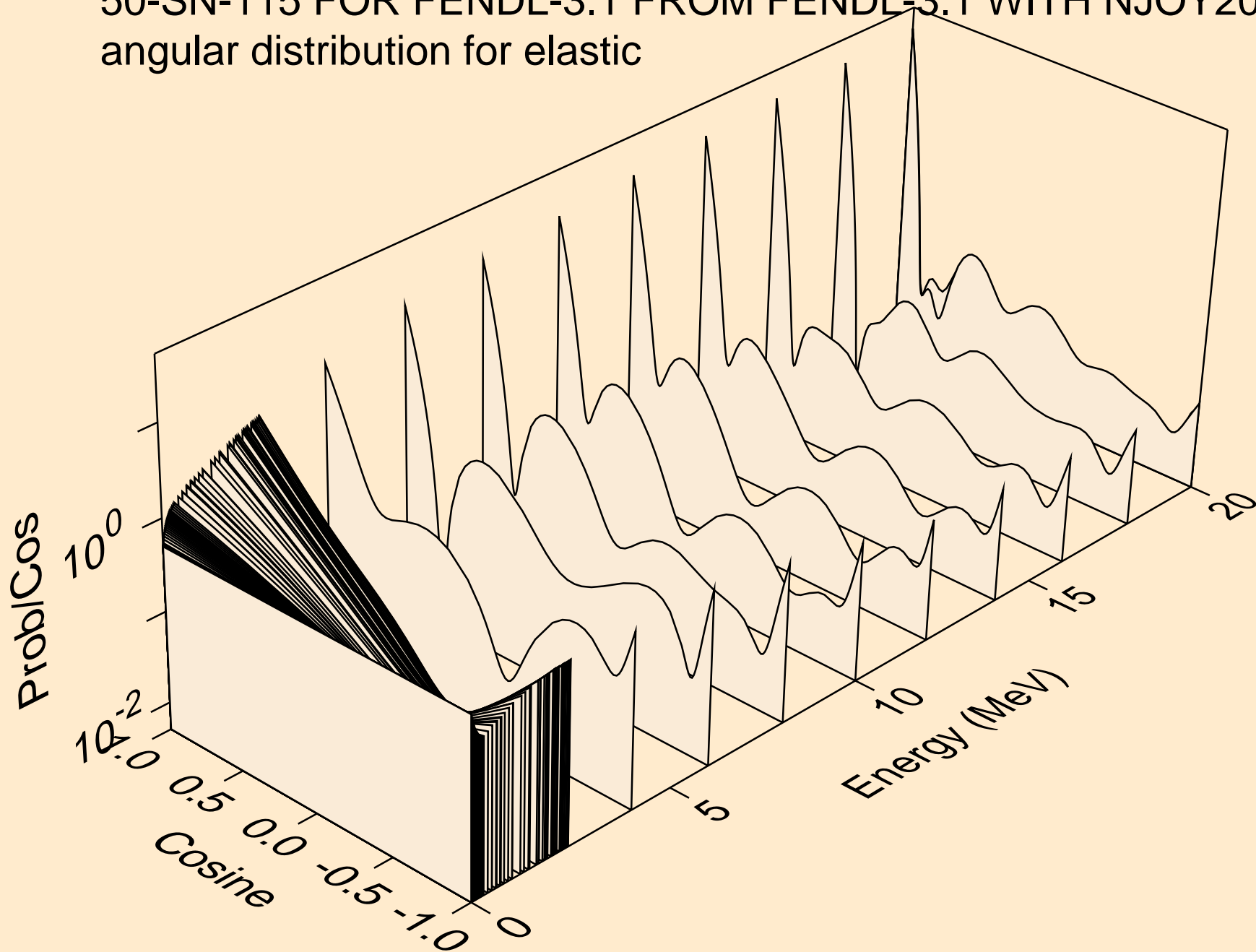

50-SN-115 FOR FENDL-3.1 FROM FENDL-3.1 WITH NJOY2012.50  
angular distribution for elastic

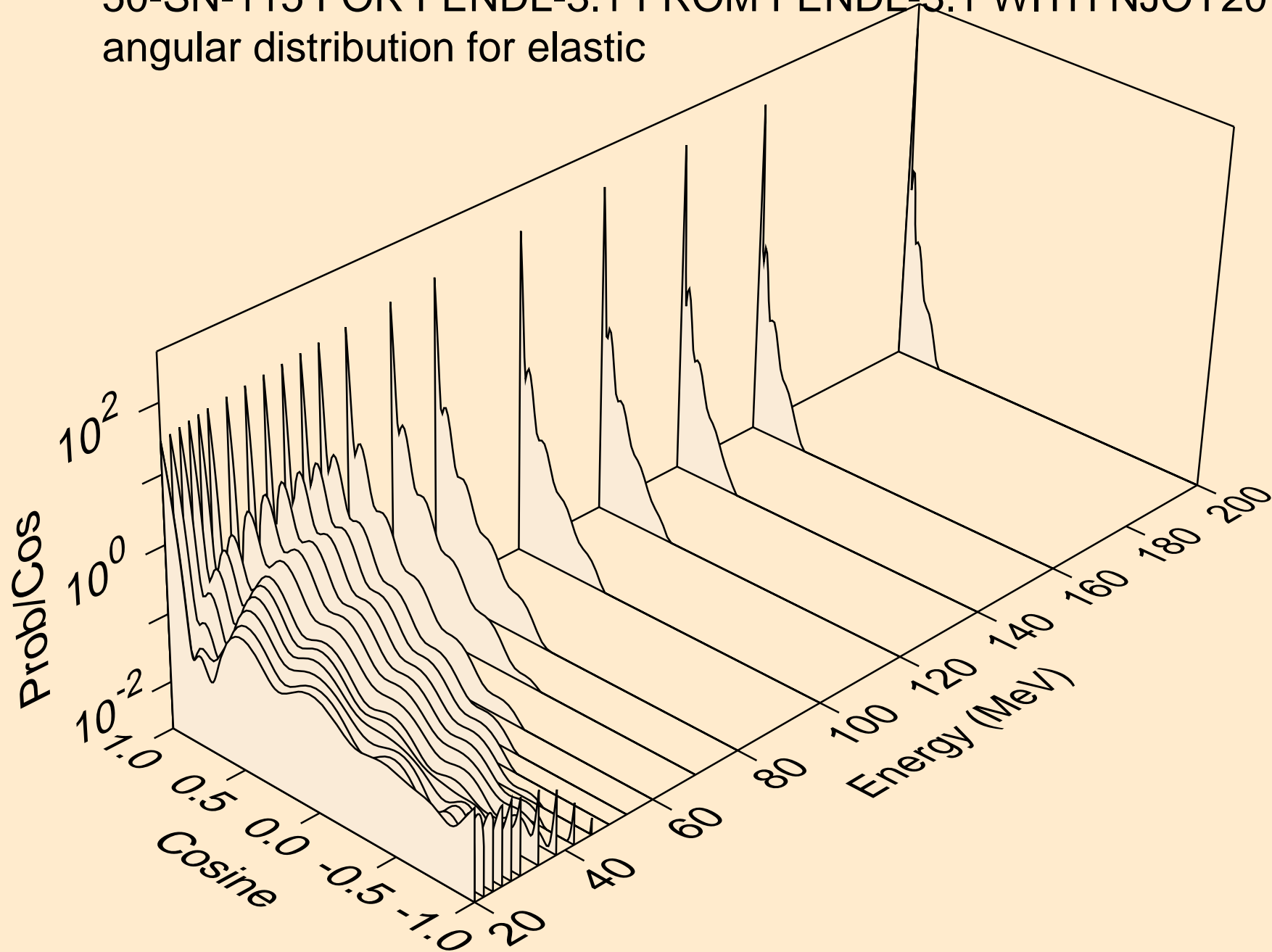

50-SN-115 FOR FENDL-3.1 FROM FENDL-3.1 WITH NJOY2012.50  
angular distribution for (n,n\*1)

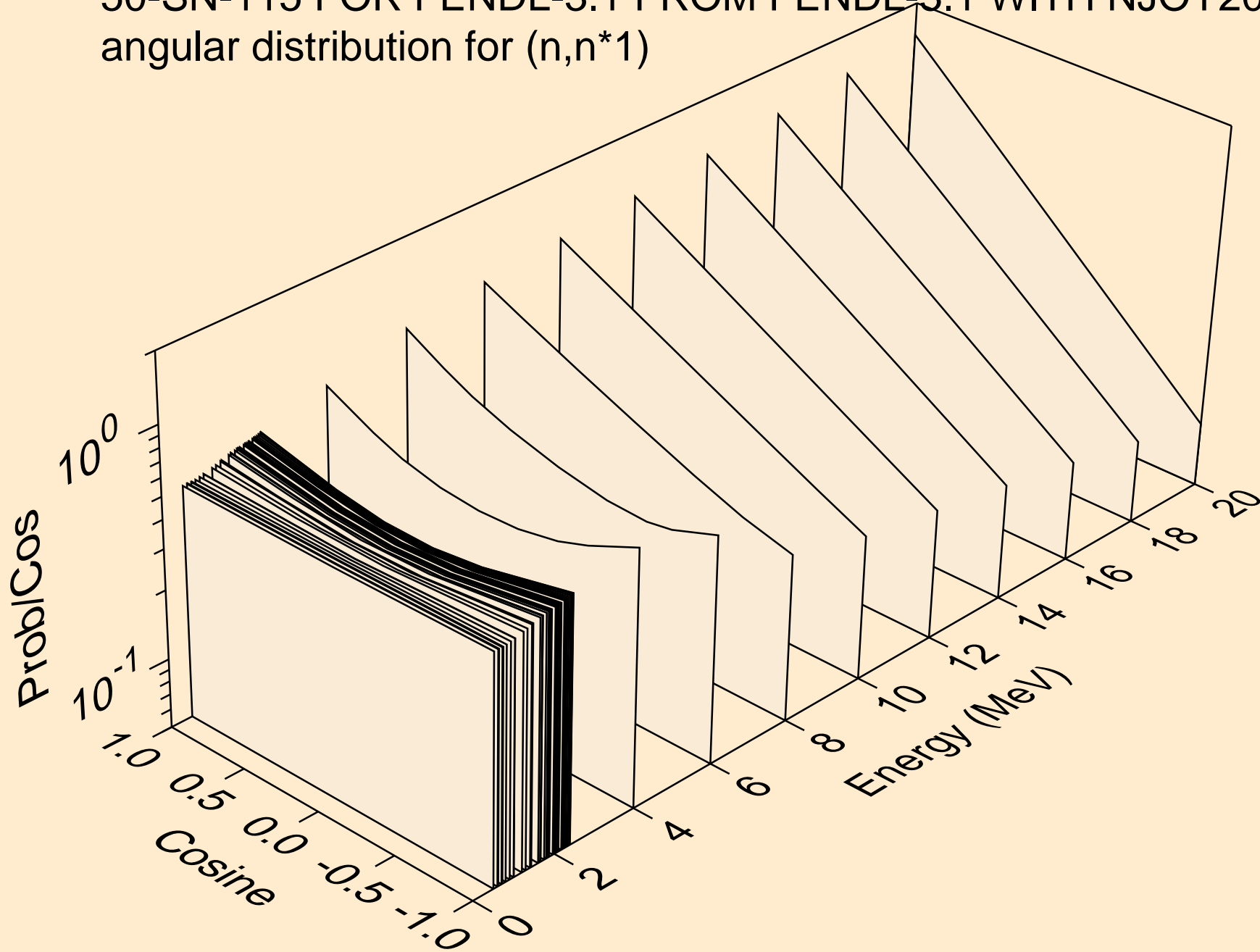

50-SN-115 FOR FENDL-3.1 FROM FENDL-3.1 WITH NJOY2012.50  
angular distribution for (n,n\*2)

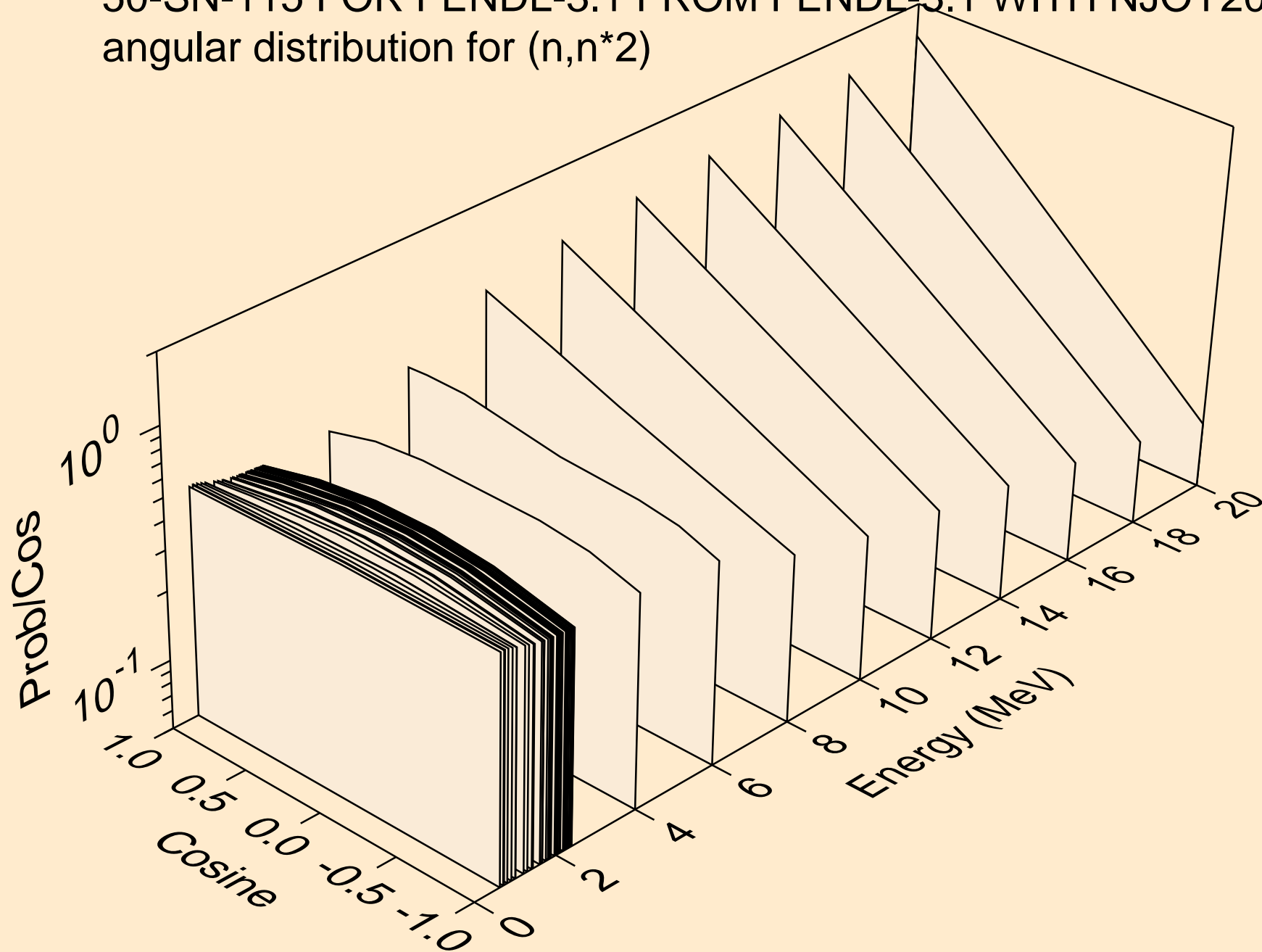

50-SN-115 FOR FENDL-3.1 FROM FENDL-3.1 WITH NJOY2012.50  
angular distribution for (n,n\*3)

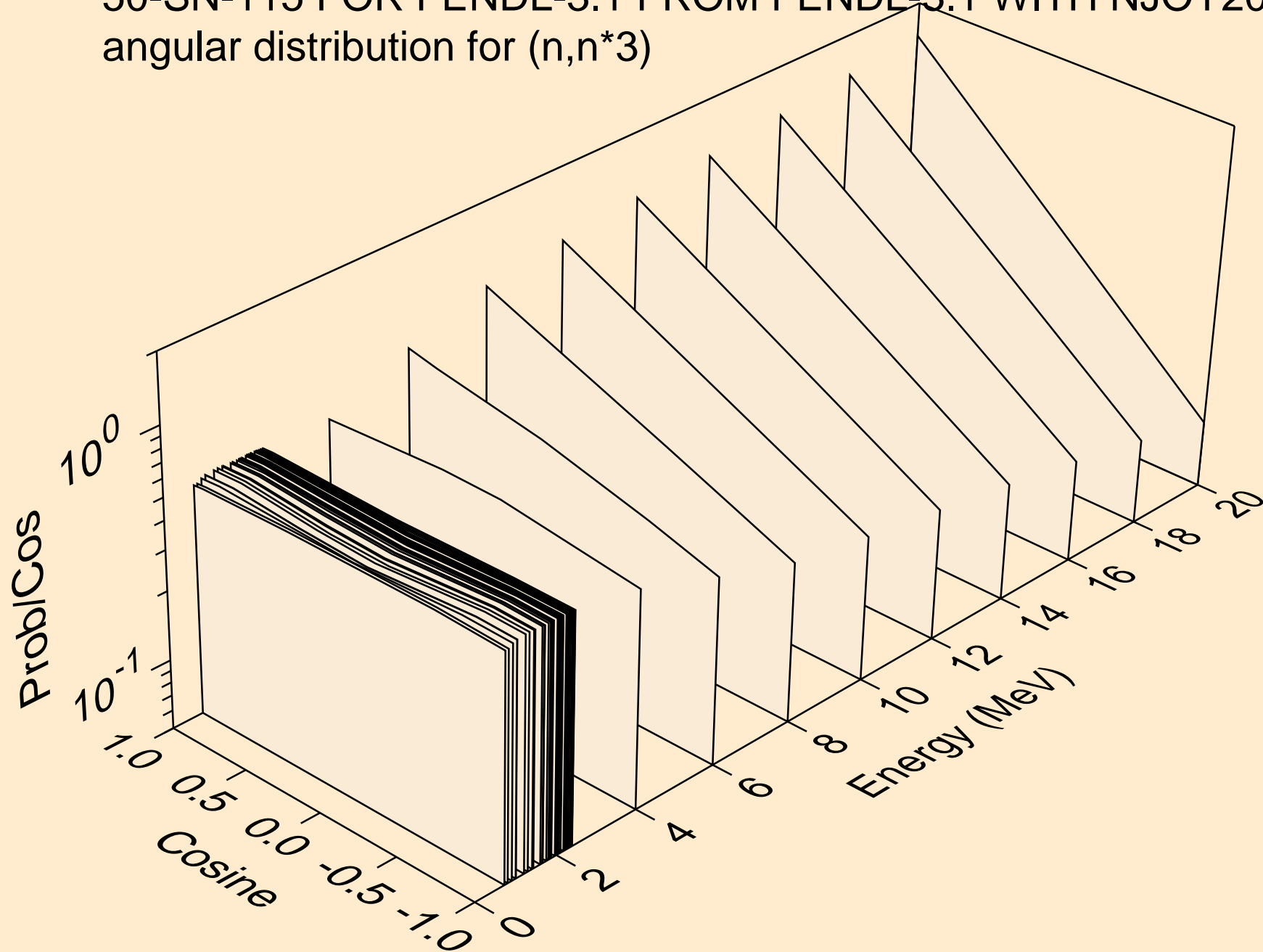

50-SN-115 FOR FENDL-3.1 FROM FENDL-3.1 WITH NJOY2012.50  
angular distribution for (n,n\*4)

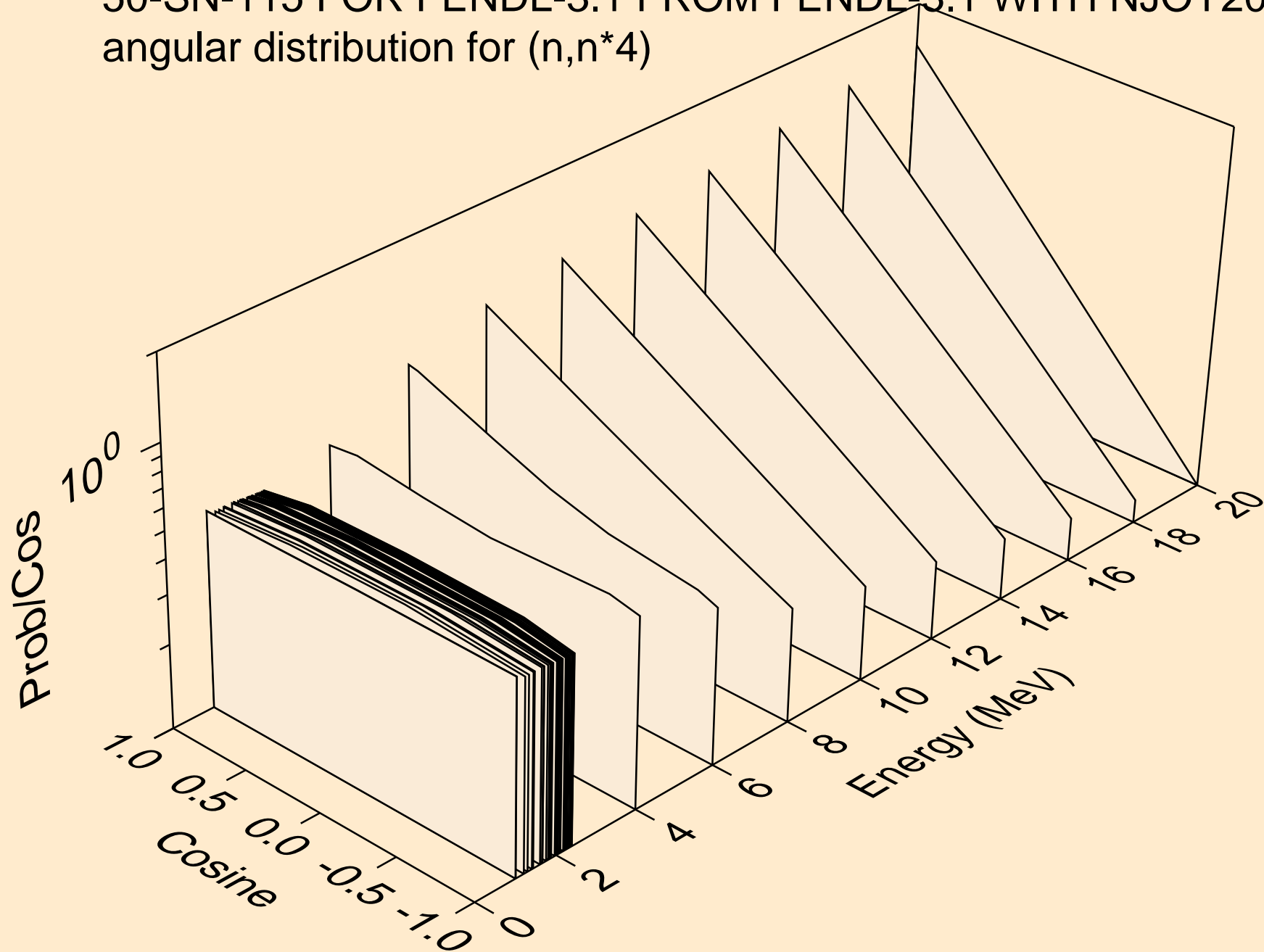



50-SN-115 FOR FENDL-3.1 FROM FENDL-3.1 WITH NJOY2012.50  
angular distribution for (n,n\*5)

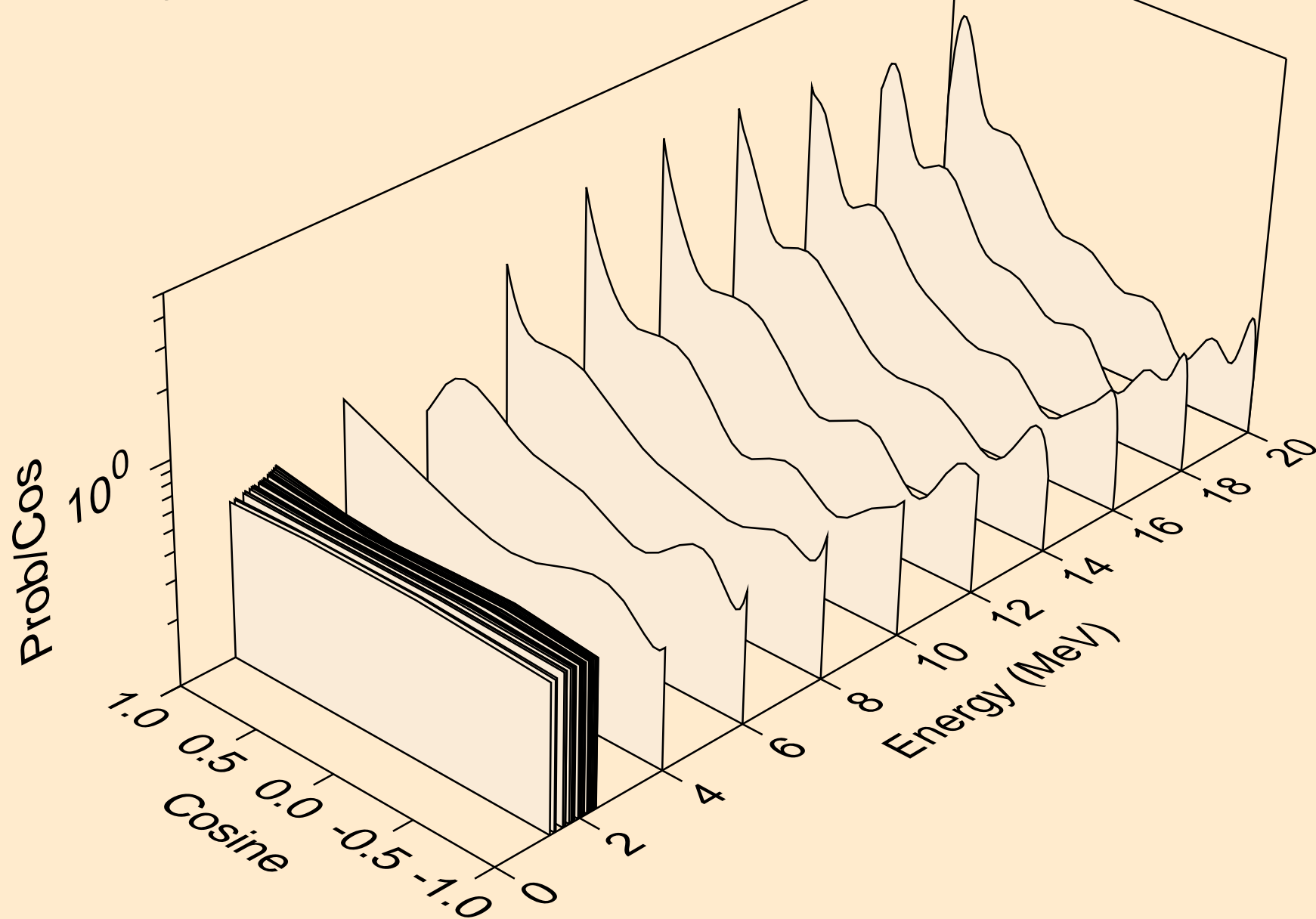

50-SN-115 FOR FENDL-3.1 FROM FENDL-3.1 WITH NJOY2012.50  
angular distribution for (n,n\*6)

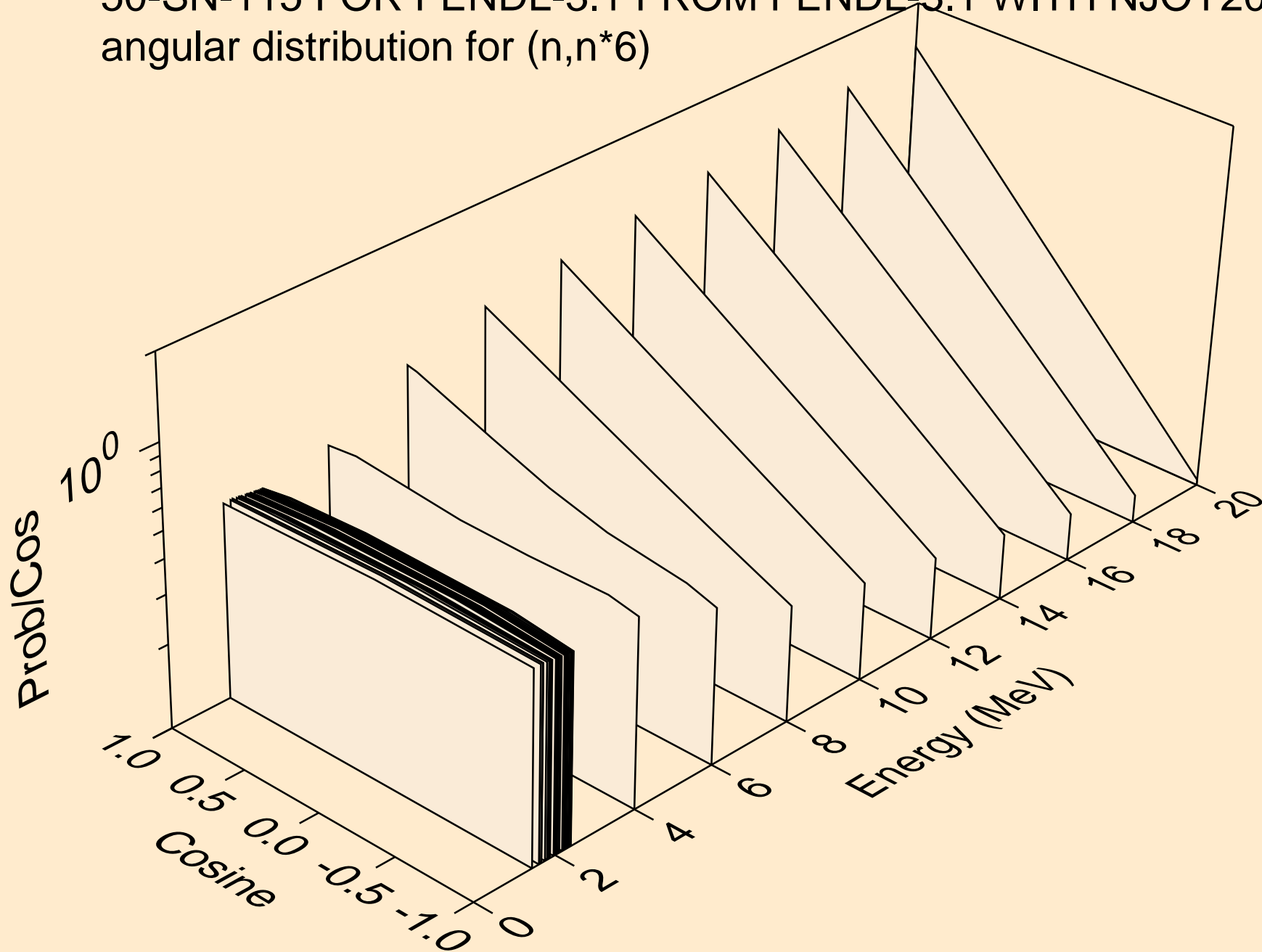

50-SN-115 FOR FENDL-3.1 FROM FENDL-3.1 WITH NJOY2012.50  
angular distribution for (n,n\*7)

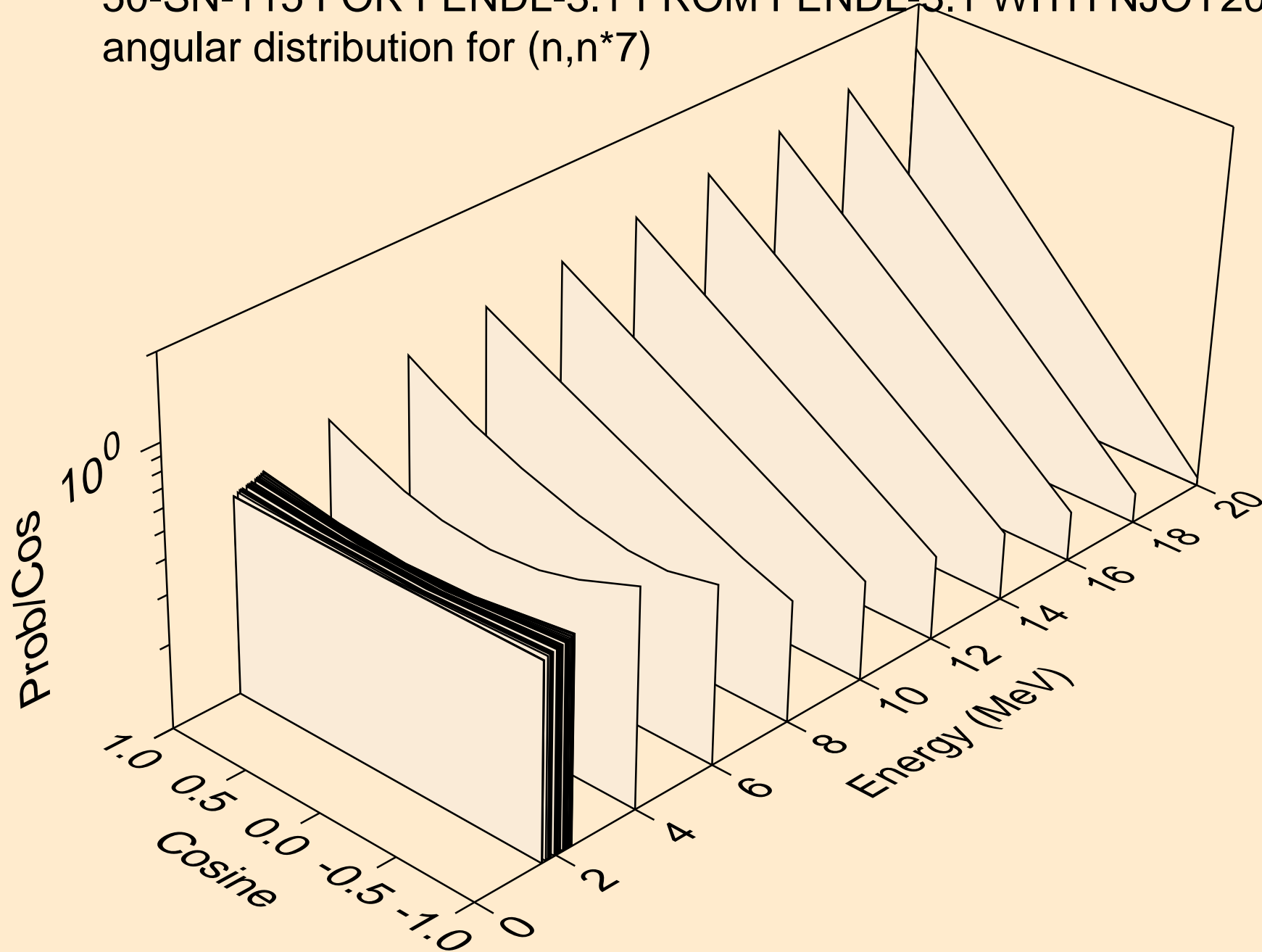

50-SN-115 FOR FENDL-3.1 FROM FENDL-3.1 WITH NJOY2012.50  
angular distribution for (n,n\*8)

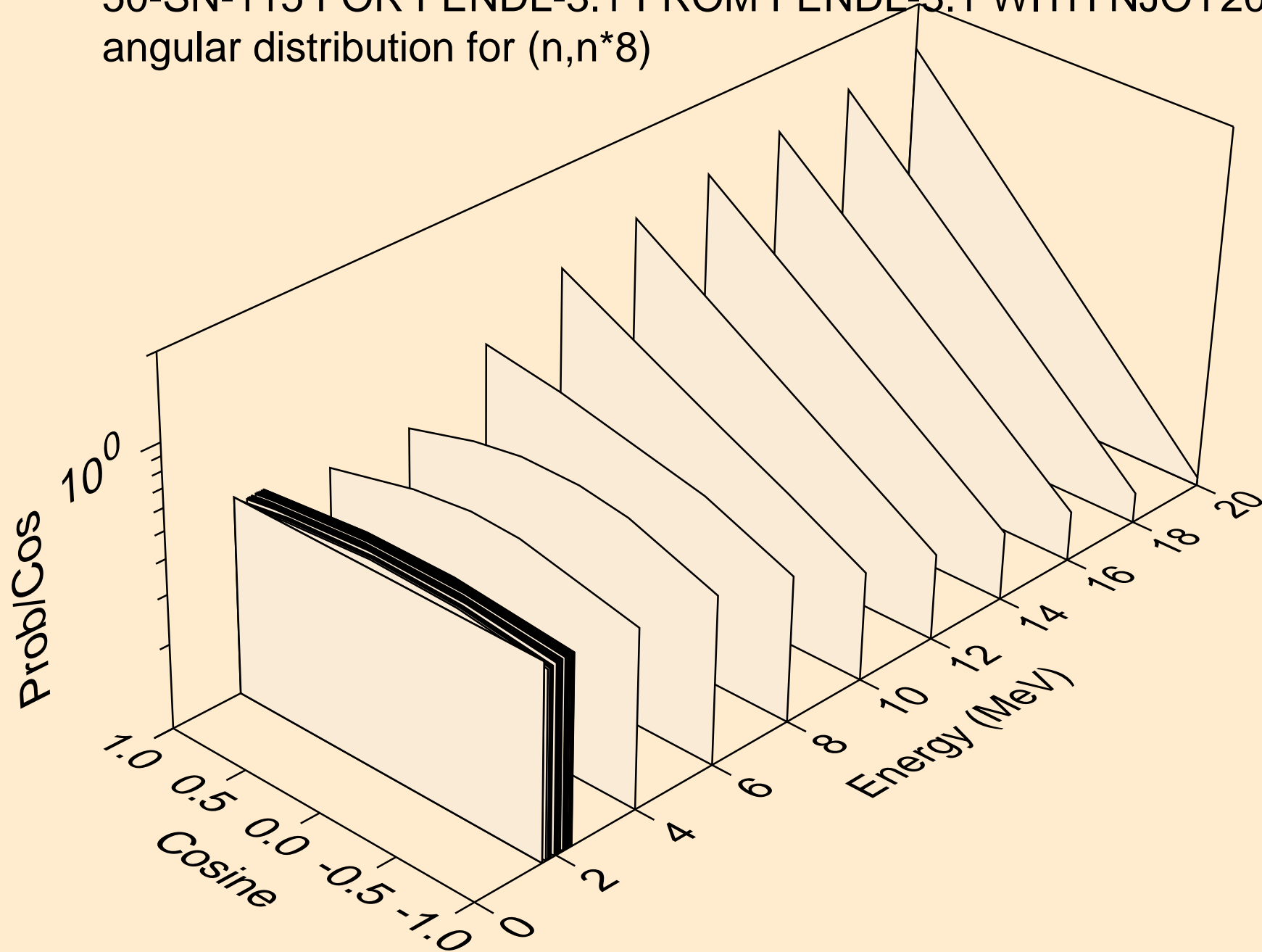

50-SN-115 FOR FENDL-3.1 FROM FENDL-3.1 WITH NJOY2012.50  
angular distribution for (n,n\*9)

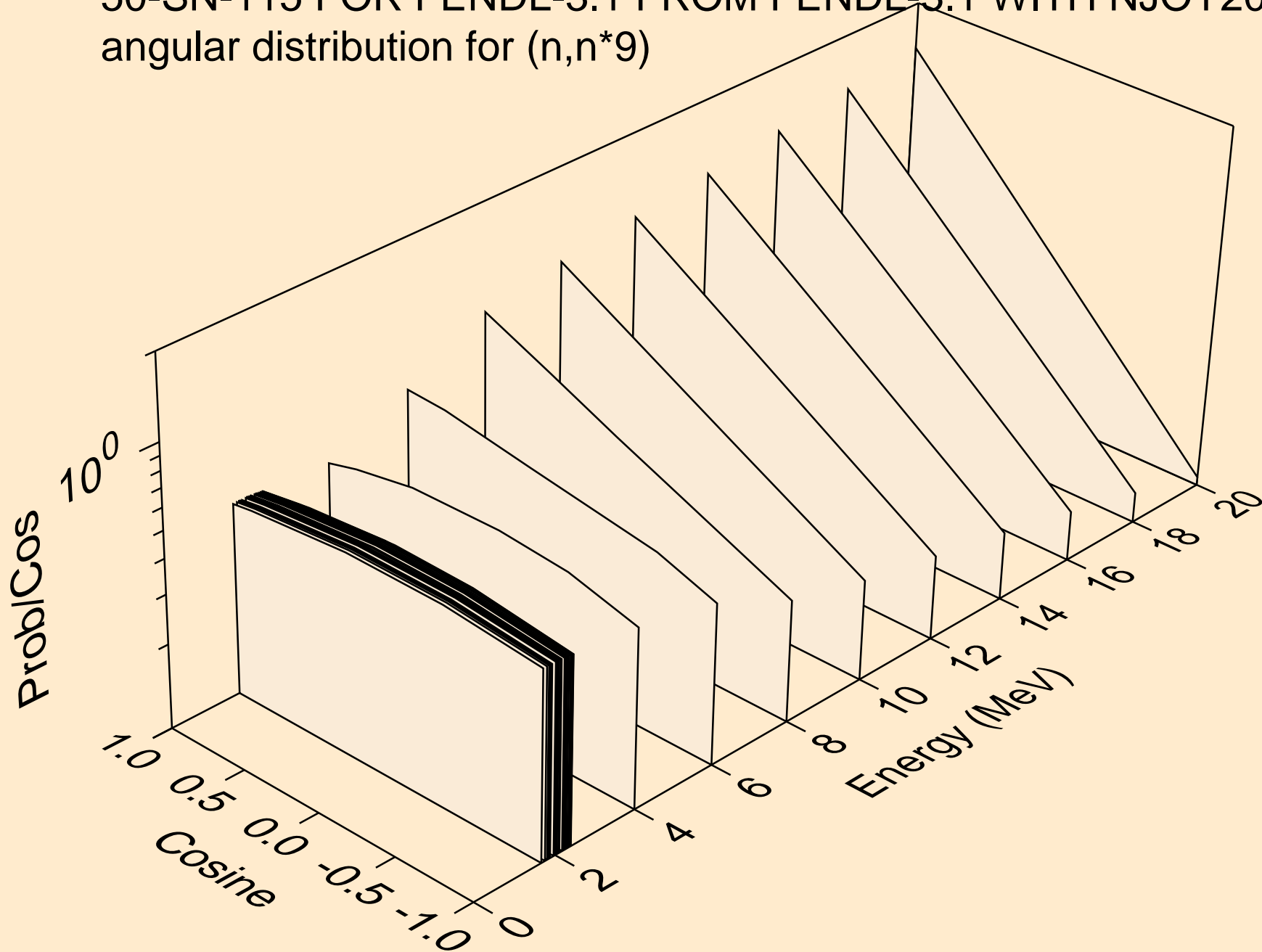

50-SN-115 FOR FENDL-3.1 FROM FENDL-3.1 WITH NJOY2012.50  
angular distribution for (n,n\*10)

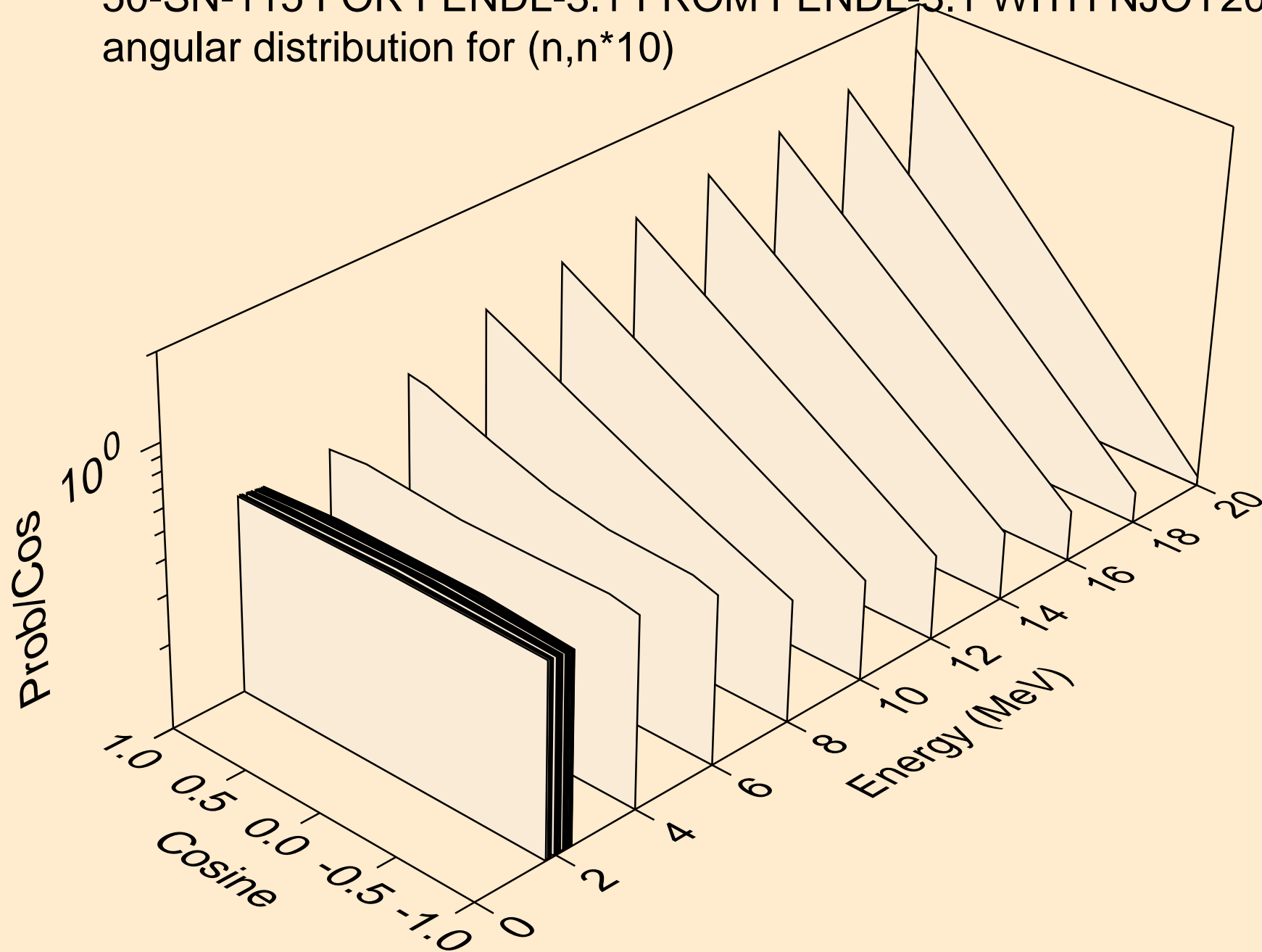

50-SN-115 FOR FENDL-3.1 FROM FENDL-3.1 WITH NJOY2012.50  
angular distribution for (n,n\*11)

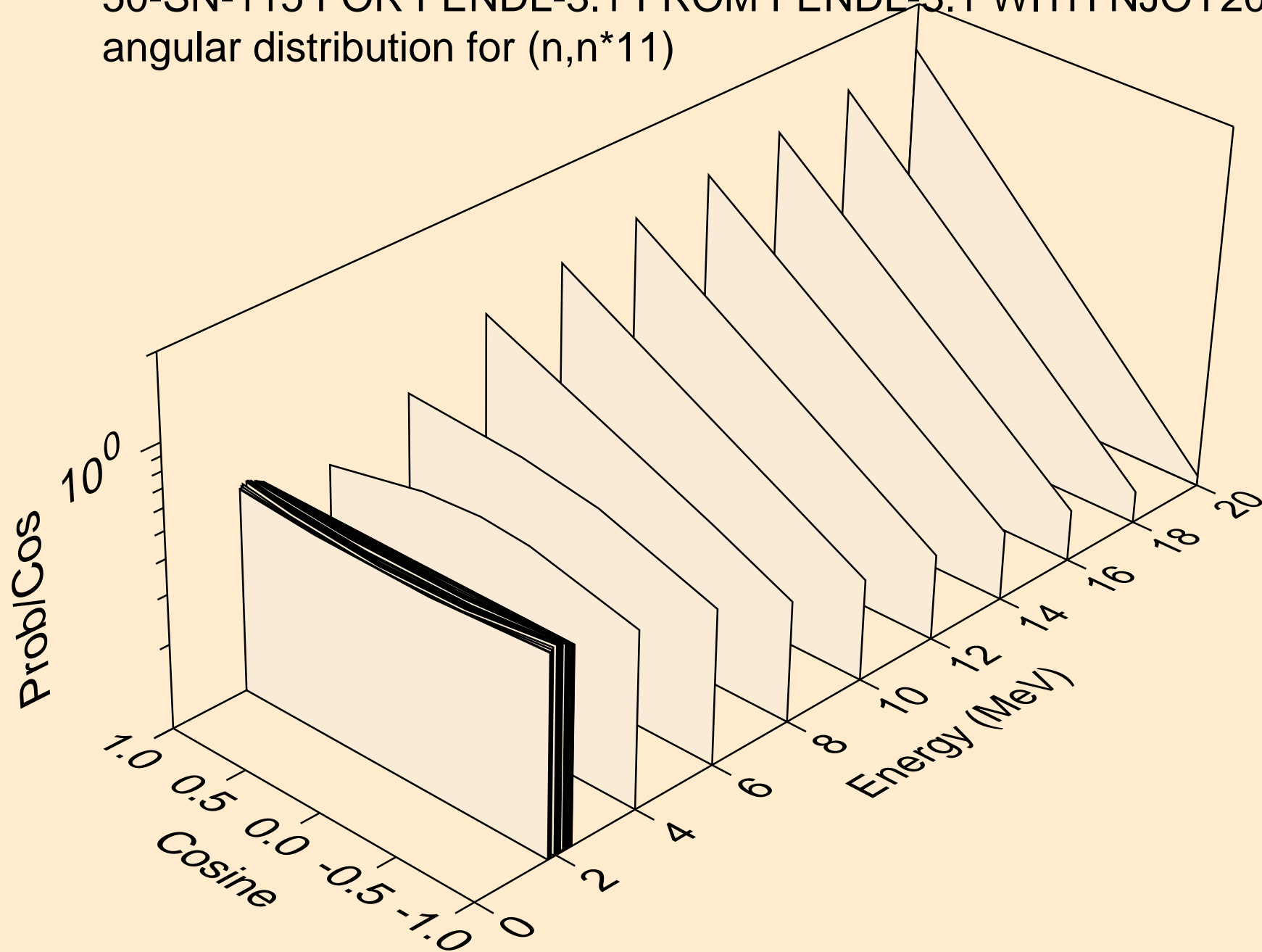

50-SN-115 FOR FENDL-3.1 FROM FENDL-3.1 WITH NJOY2012.50  
angular distribution for (n,n\*12)

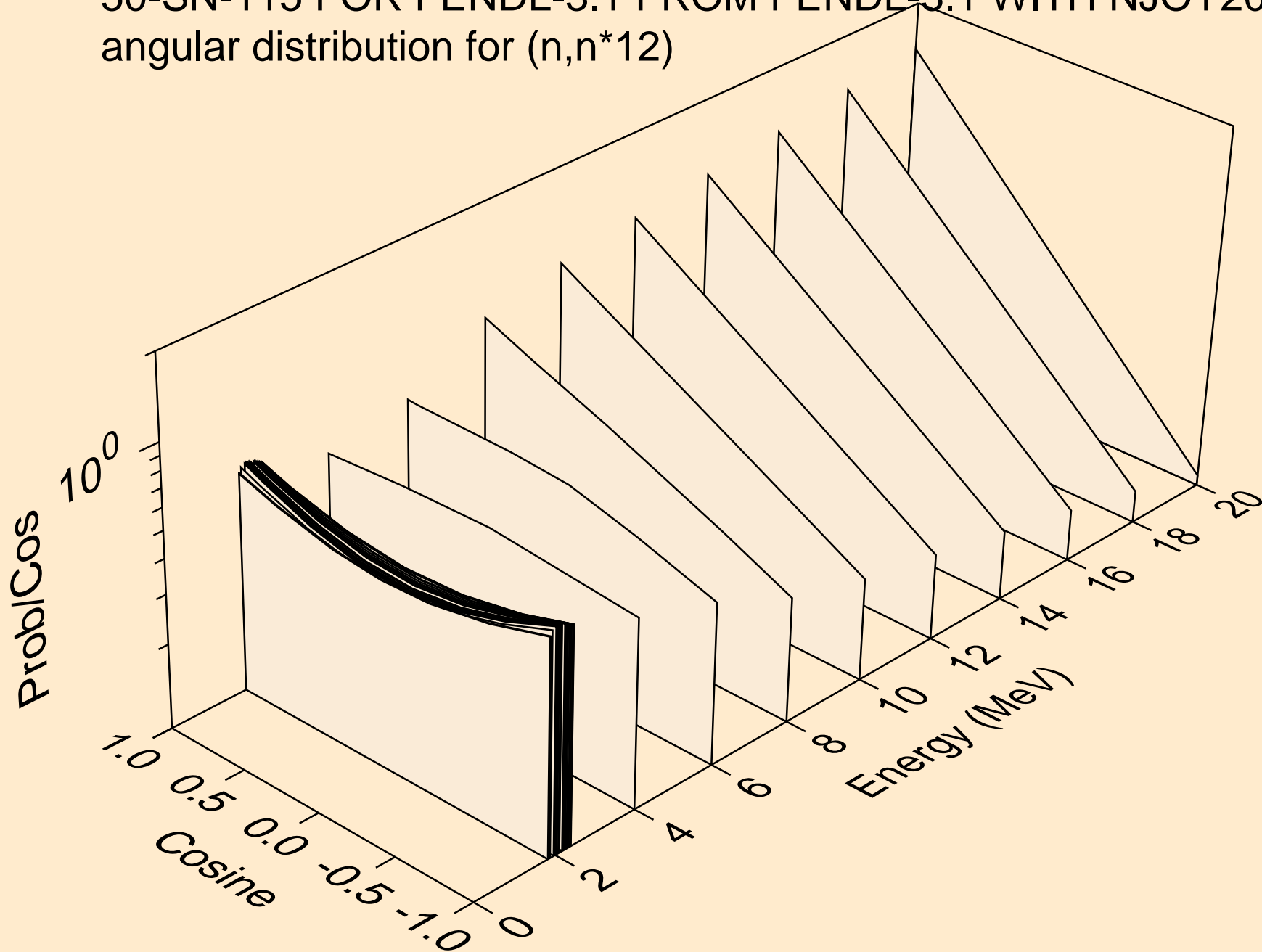



50-SN-115 FOR FENDL-3.1 FROM FENDL-3.1 WITH NJOY2012.50  
angular distribution for (n,n\*13)

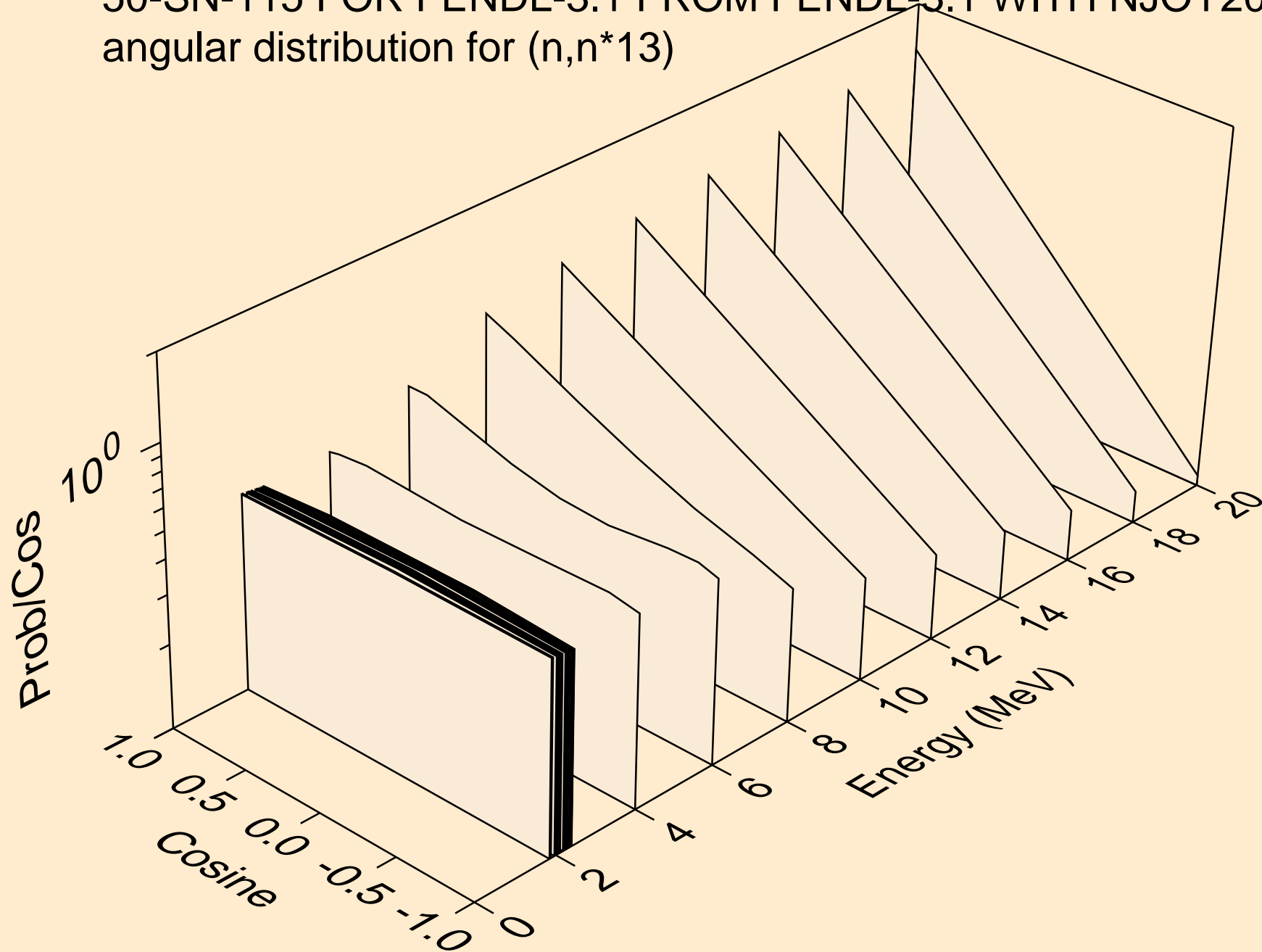

50-SN-115 FOR FENDL-3.1 FROM FENDL-3.1 WITH NJOY2012.50  
angular distribution for (n,n\*14)

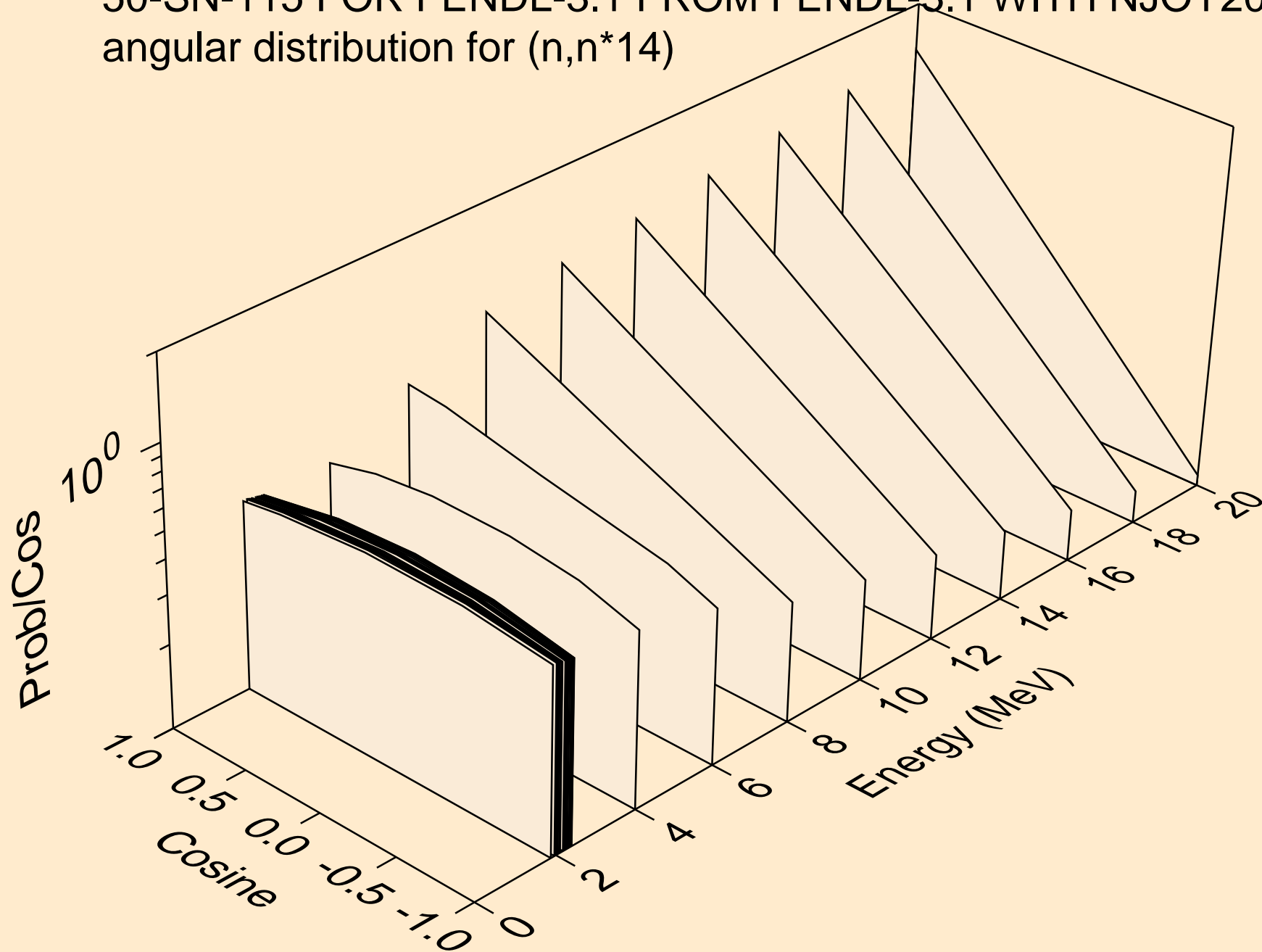

50-SN-115 FOR FENDL-3.1 FROM FENDL-3.1 WITH NJOY2012.50  
angular distribution for (n,n\*15)

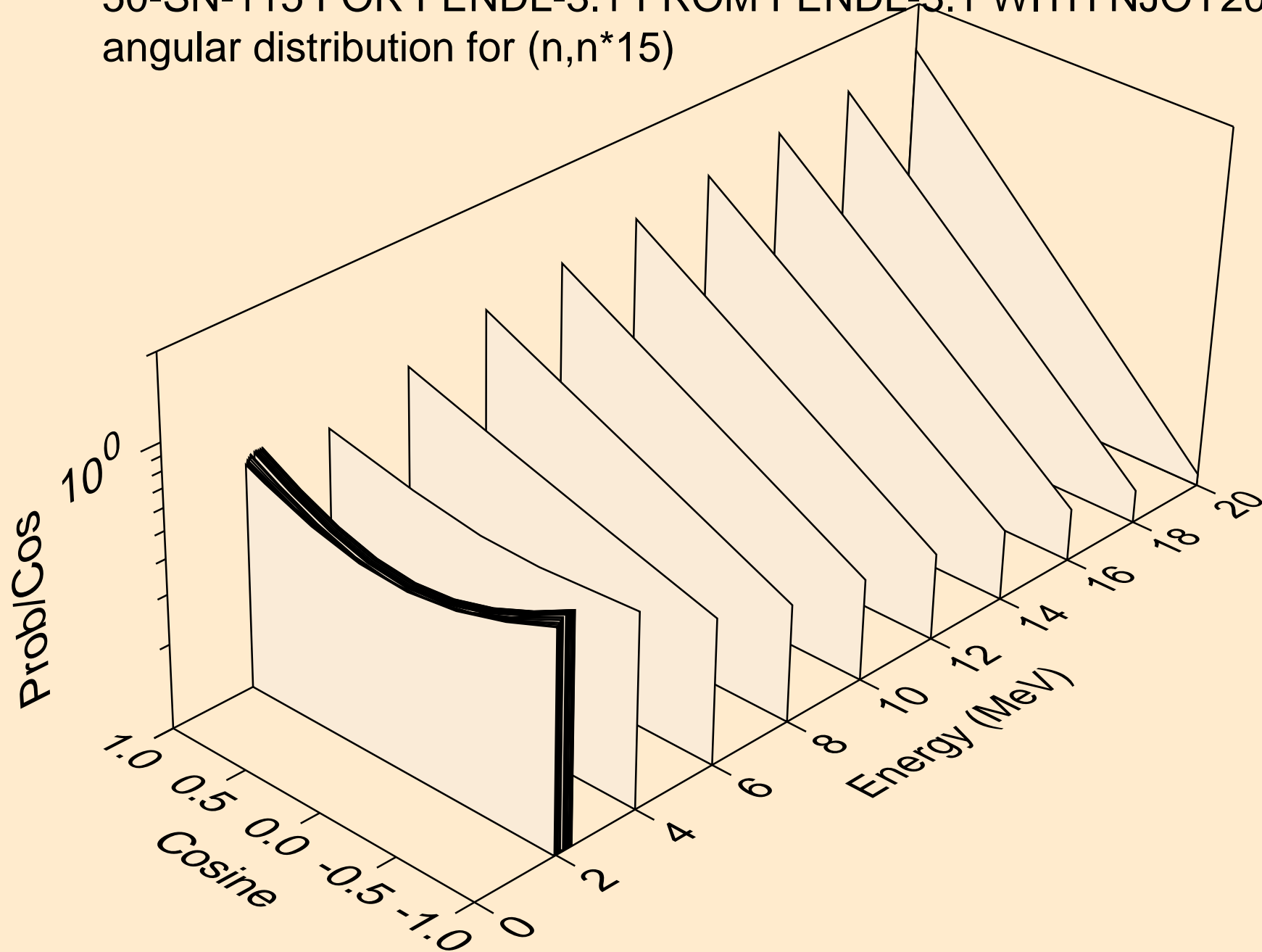

50-SN-115 FOR FENDL-3.1 FROM FENDL-3.1 WITH NJOY2012.50  
angular distribution for (n,n\*16)

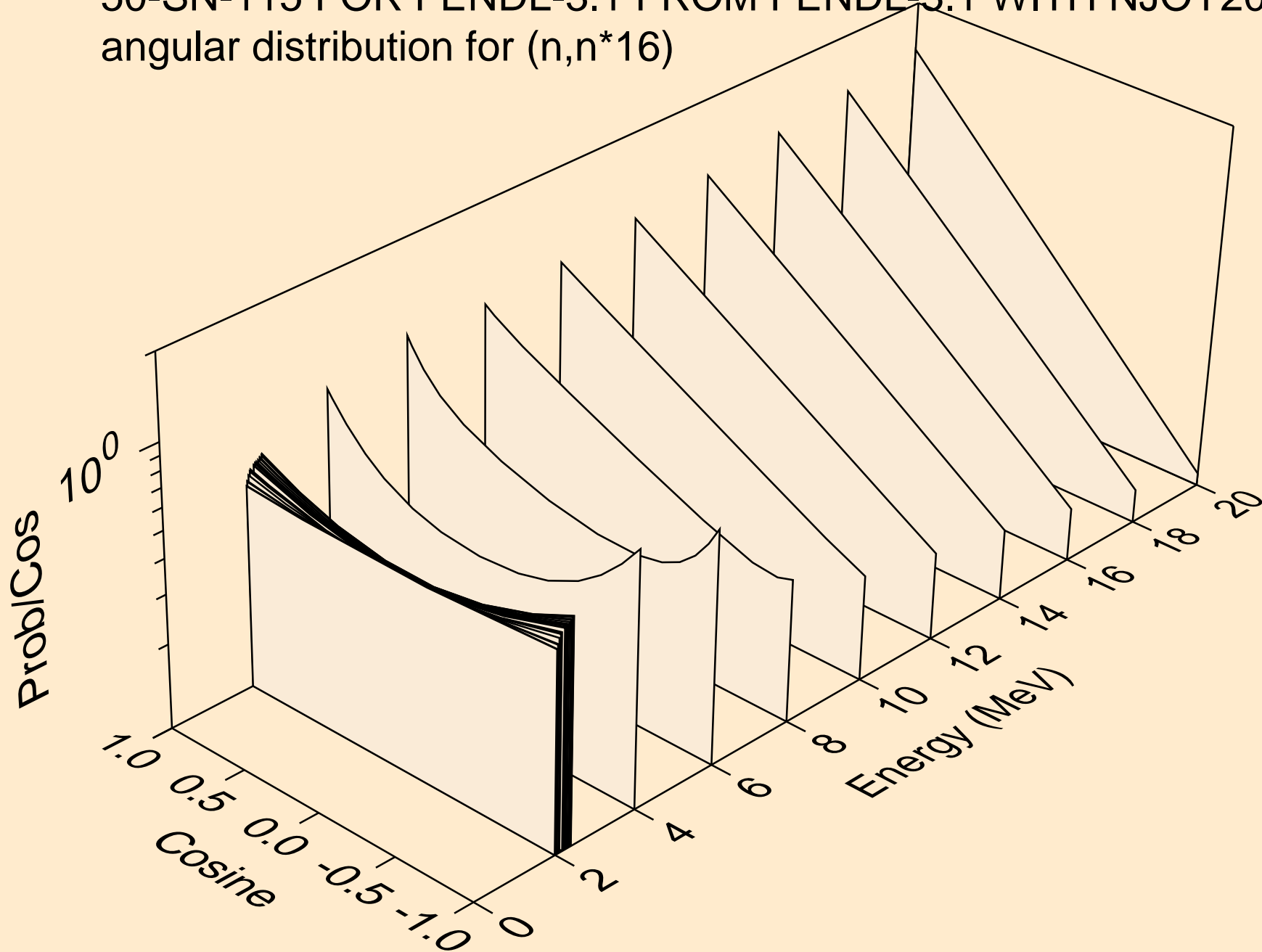

50-SN-115 FOR FENDL-3.1 FROM FENDL-3.1 WITH NJOY2012.50  
angular distribution for (n,n\*17)

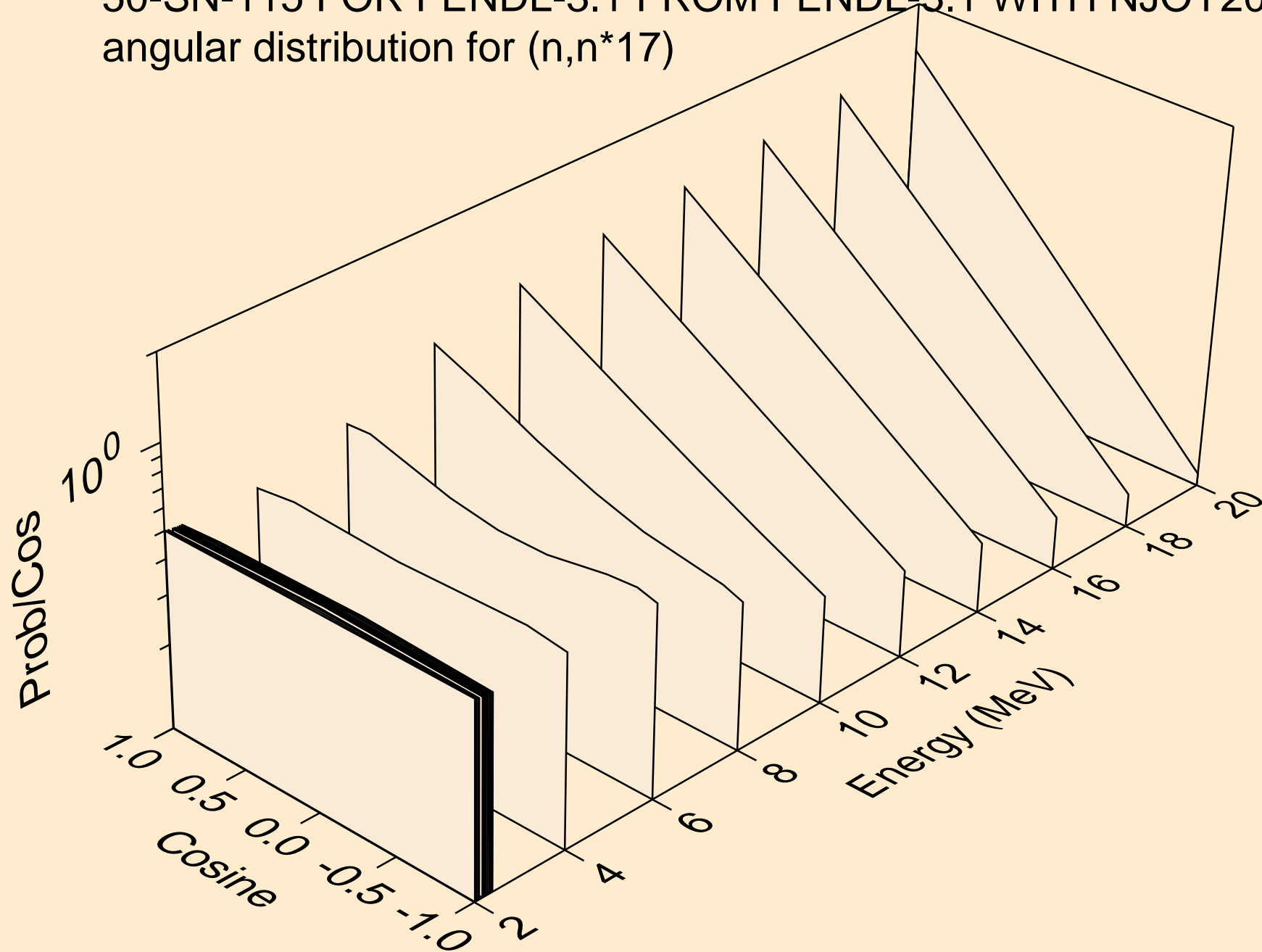

50-SN-115 FOR FENDL-3.1 FROM FENDL-3.1 WITH NJOY2012.50  
angular distribution for (n,n\*18)

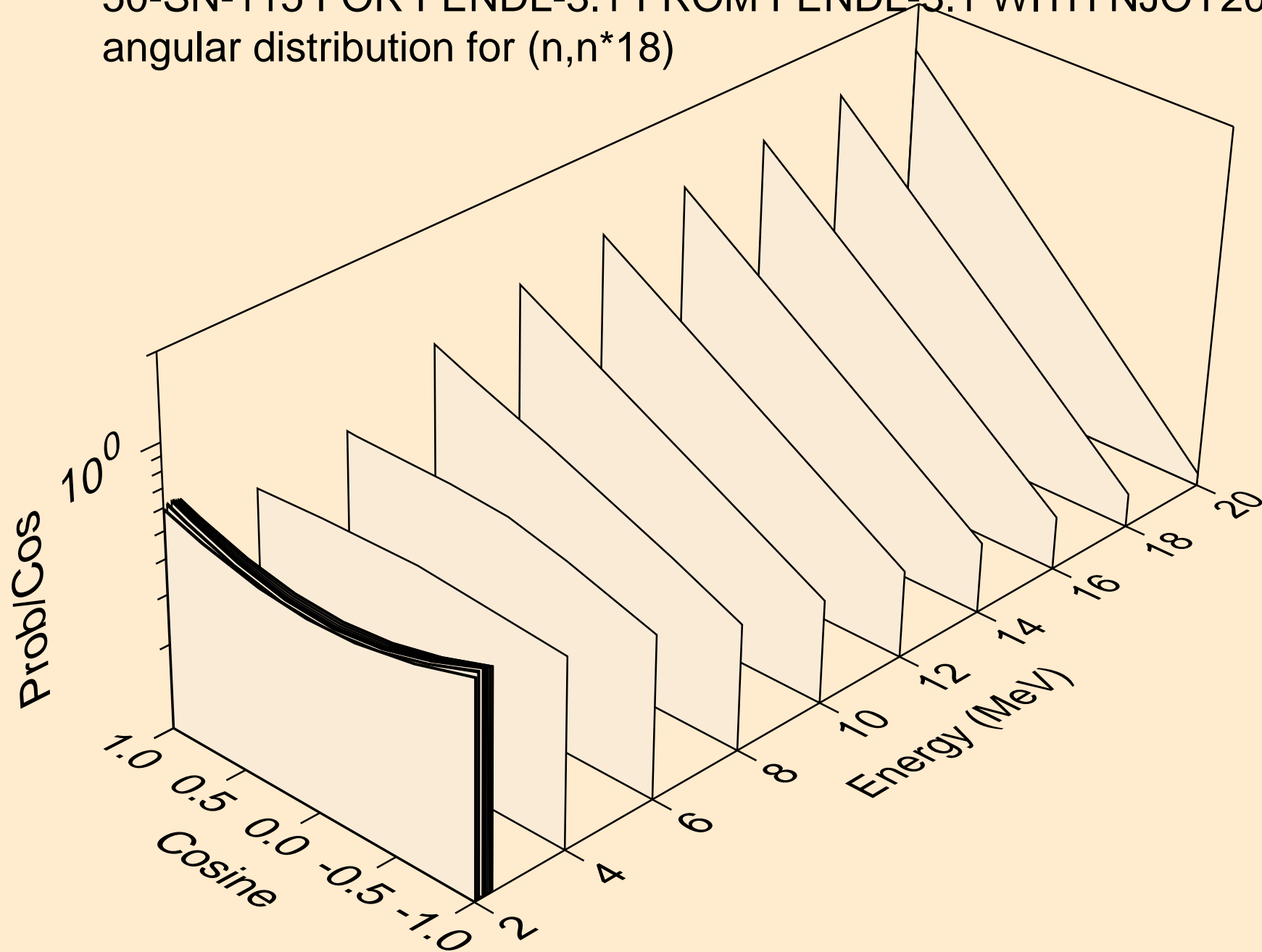

50-SN-115 FOR FENDL-3.1 FROM FENDL-3.1 WITH NJOY2012.50  
angular distribution for (n,n\*19)

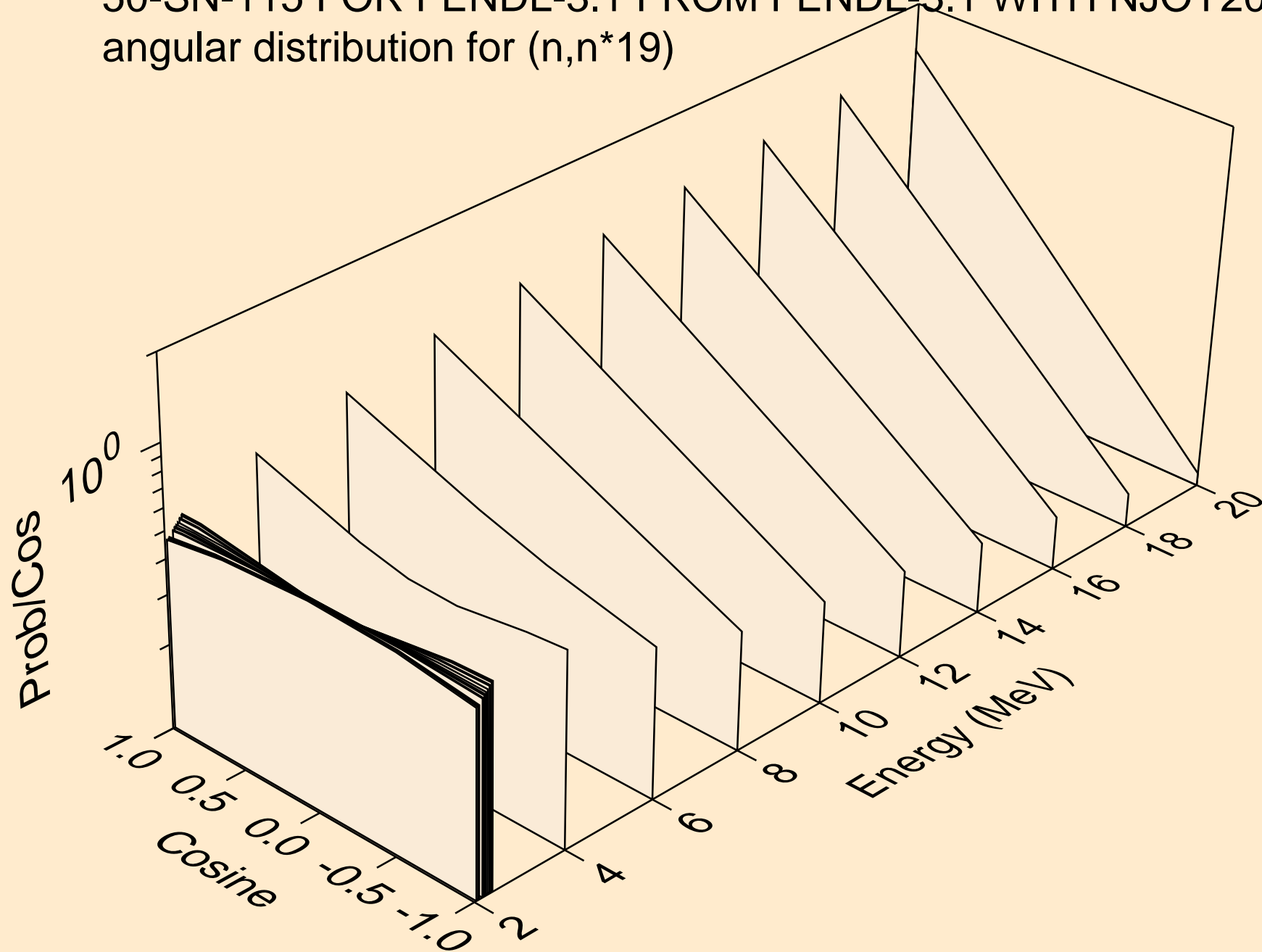

50-SN-115 FOR FENDL-3.1 FROM FENDL-3.1 WITH NJOY2012.50  
angular distribution for (n,n\*20)

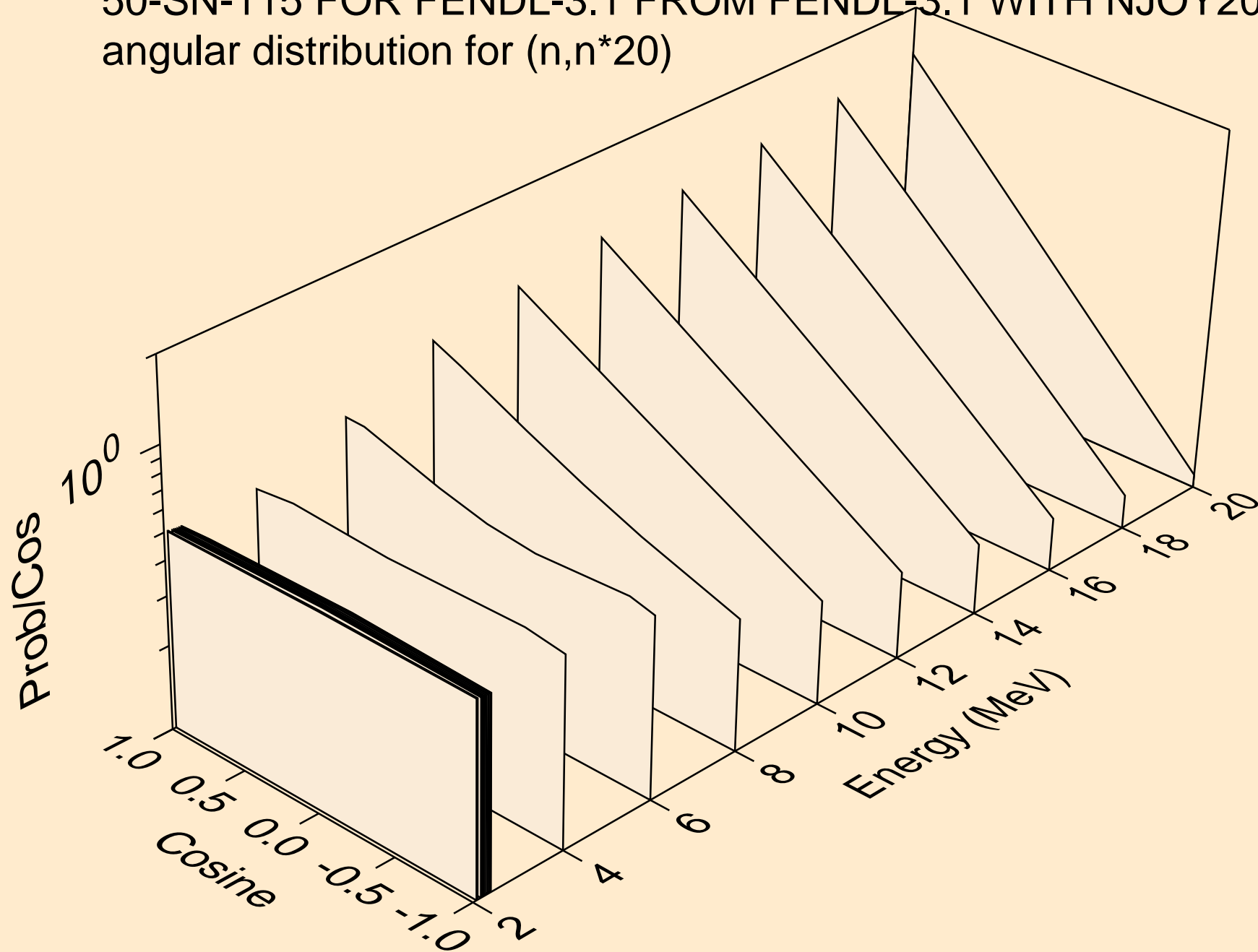



50-SN-115 FOR FENDL-3.1 FROM FENDL-3.1 WITH NJOY2012.50  
angular distribution for (n,n\*21)

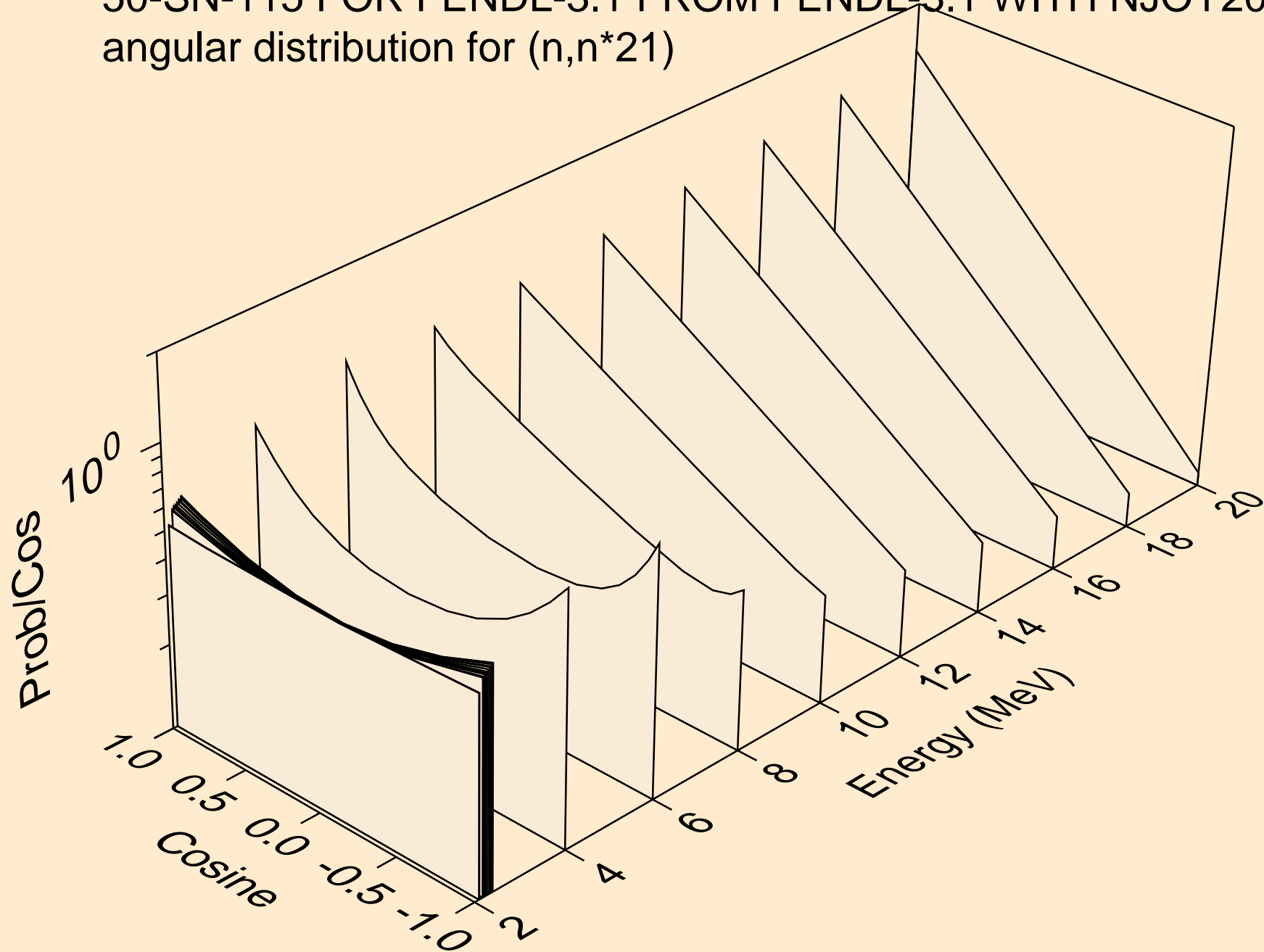

50-SN-115 FOR FENDL-3.1 FROM FENDL-3.1 WITH NJOY2012.50  
angular distribution for (n,n\*22)

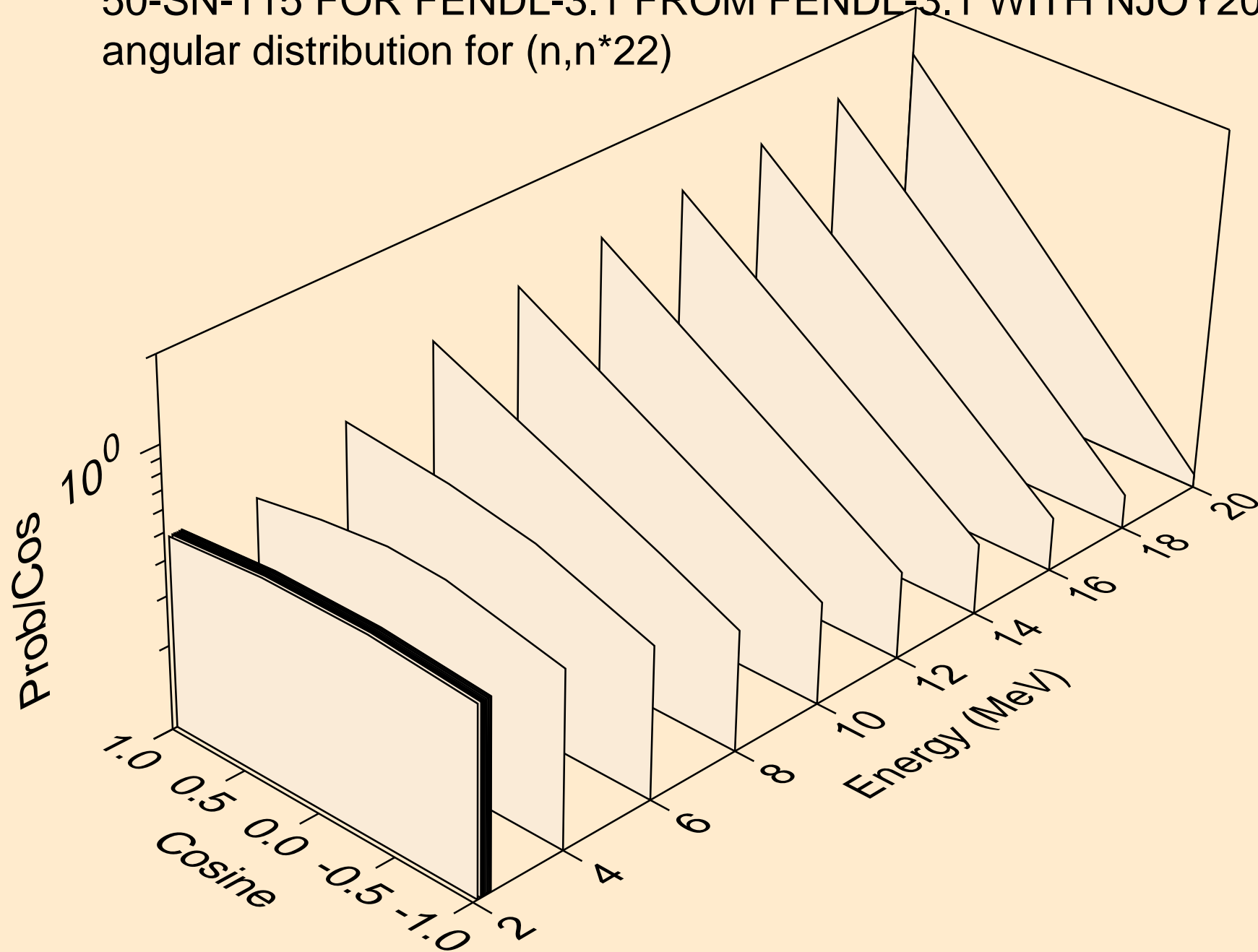

50-SN-115 FOR FENDL-3.1 FROM FENDL-3.1 WITH NJOY2012.50  
angular distribution for (n,n\*23)

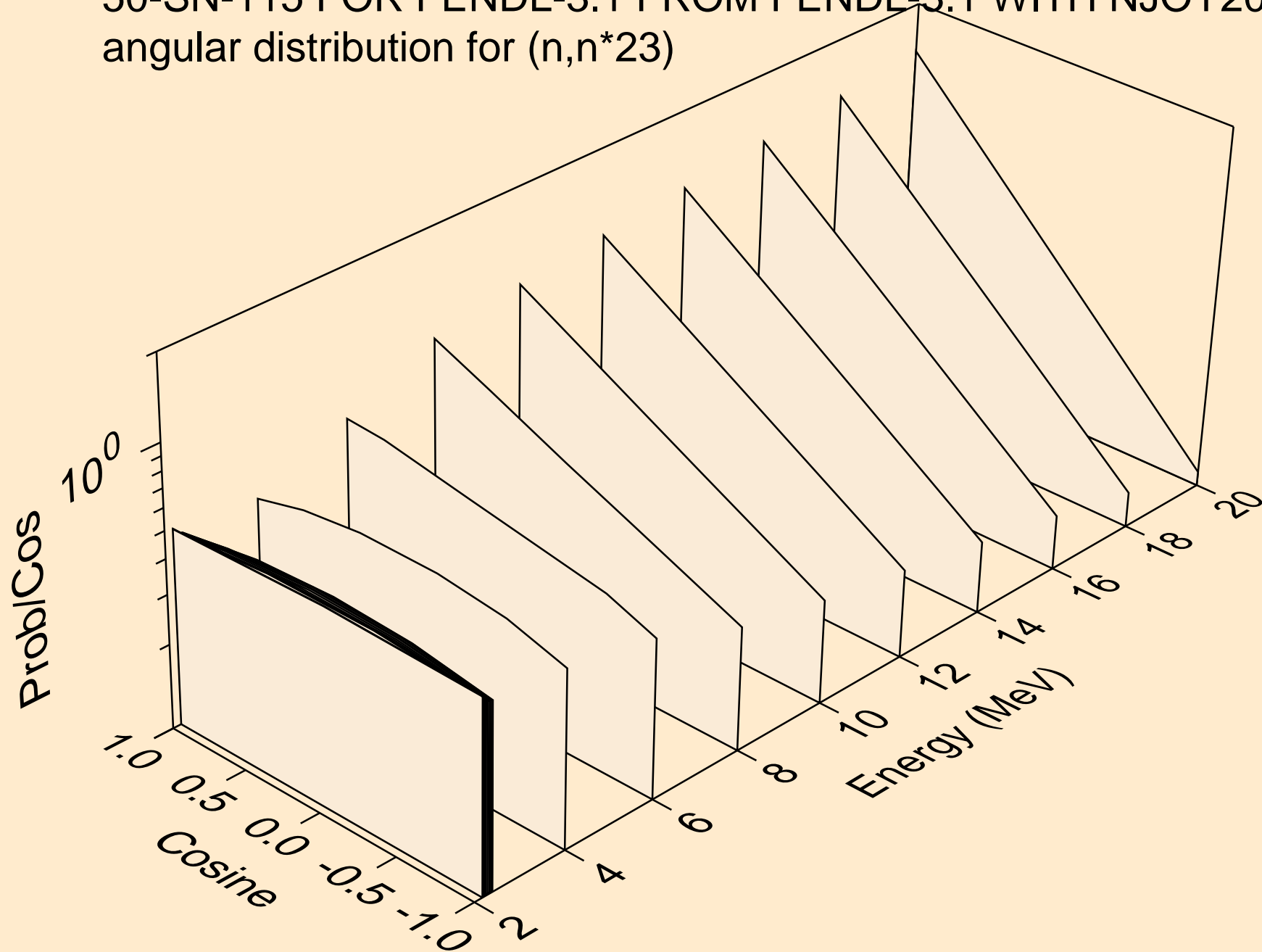

50-SN-115 FOR FENDL-3.1 FROM FENDL-3.1 WITH NJOY2012.50  
angular distribution for (n,n\*24)

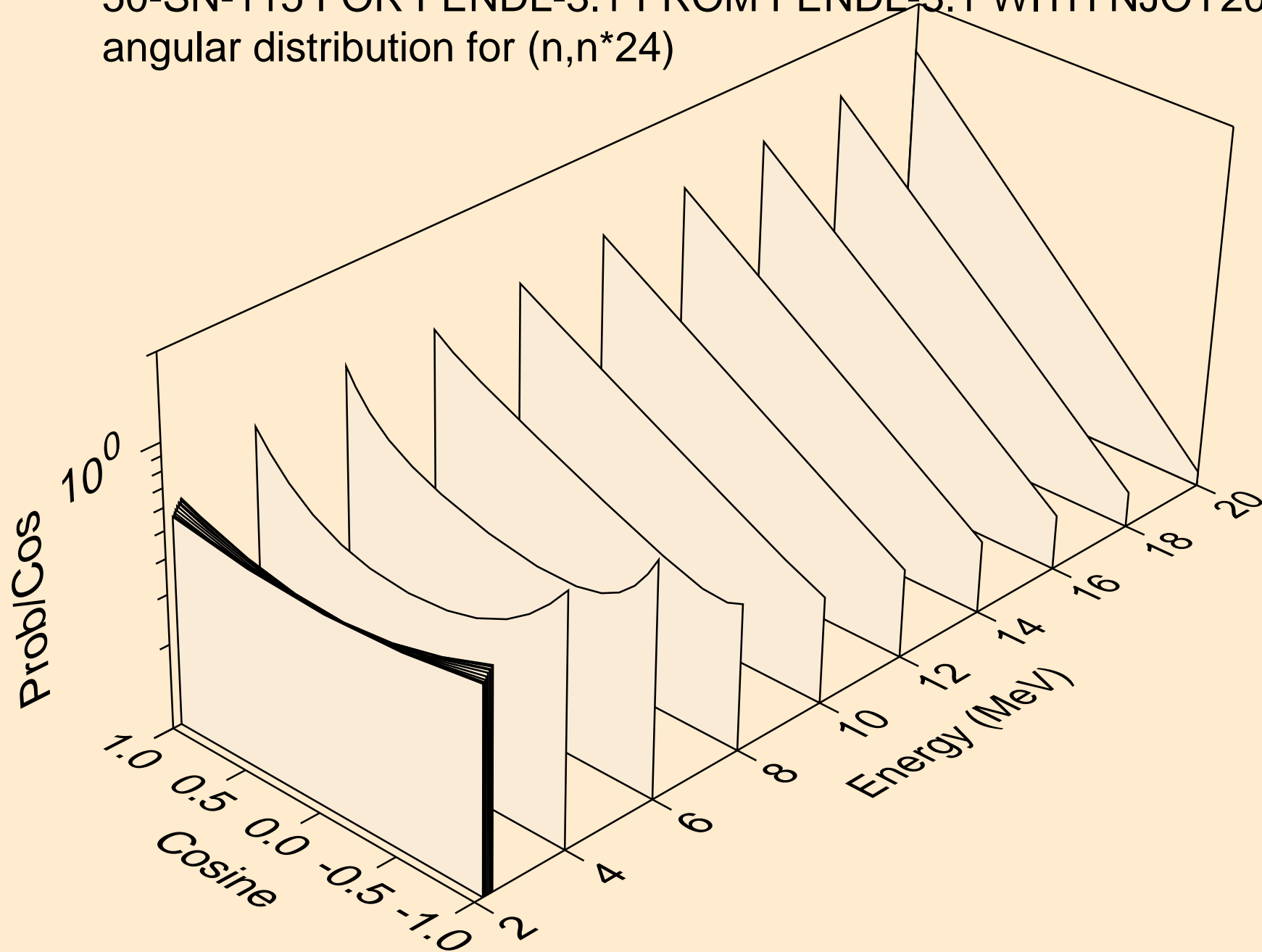

50-SN-115 FOR FENDL-3.1 FROM FENDL-3.1 WITH NJOY2012.50  
angular distribution for (n,n\*25)

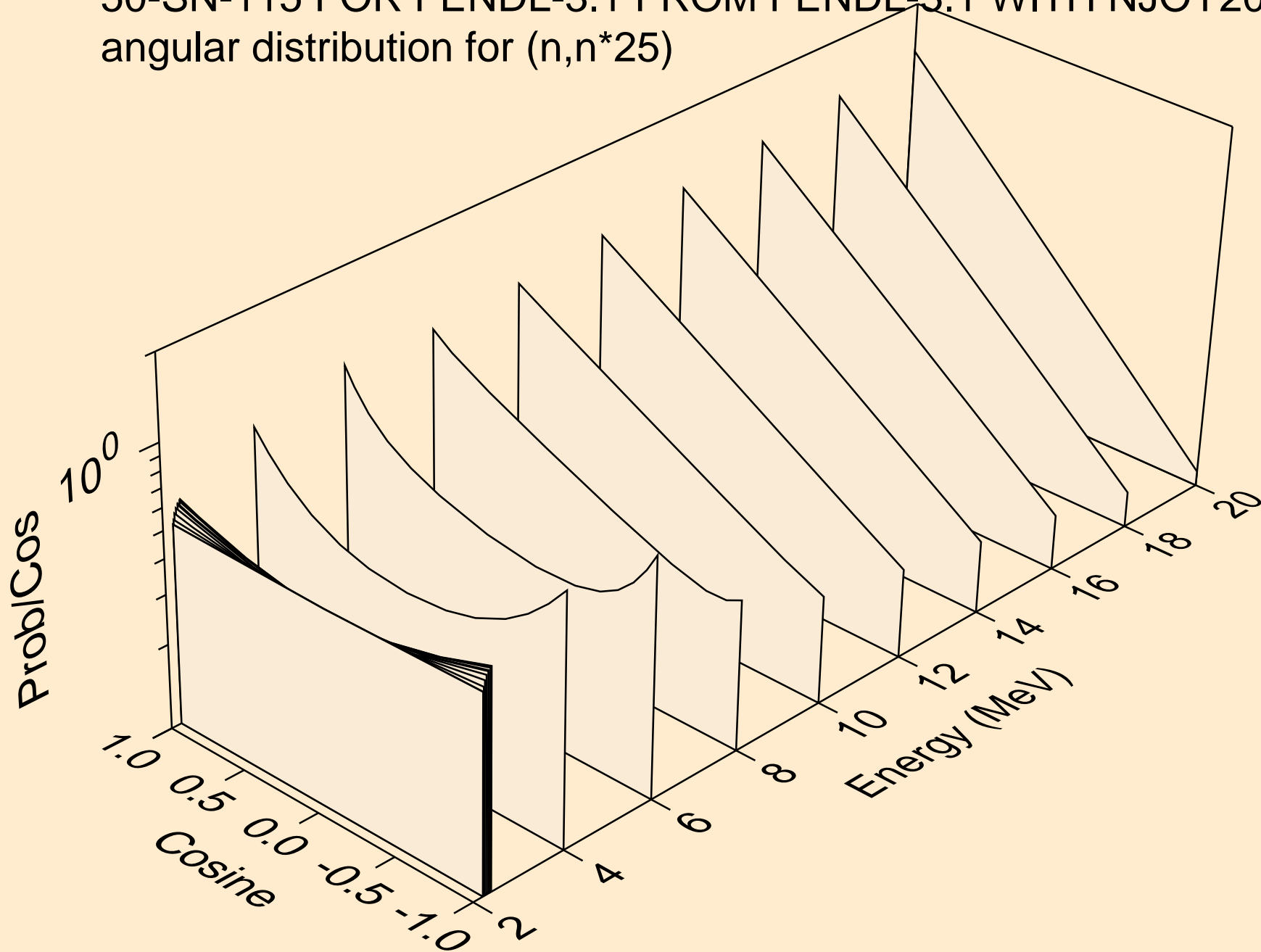

50-SN-115 FOR FENDL-3.1 FROM FENDL-3.1 WITH NJOY2012.50  
angular distribution for (n,n\*26)

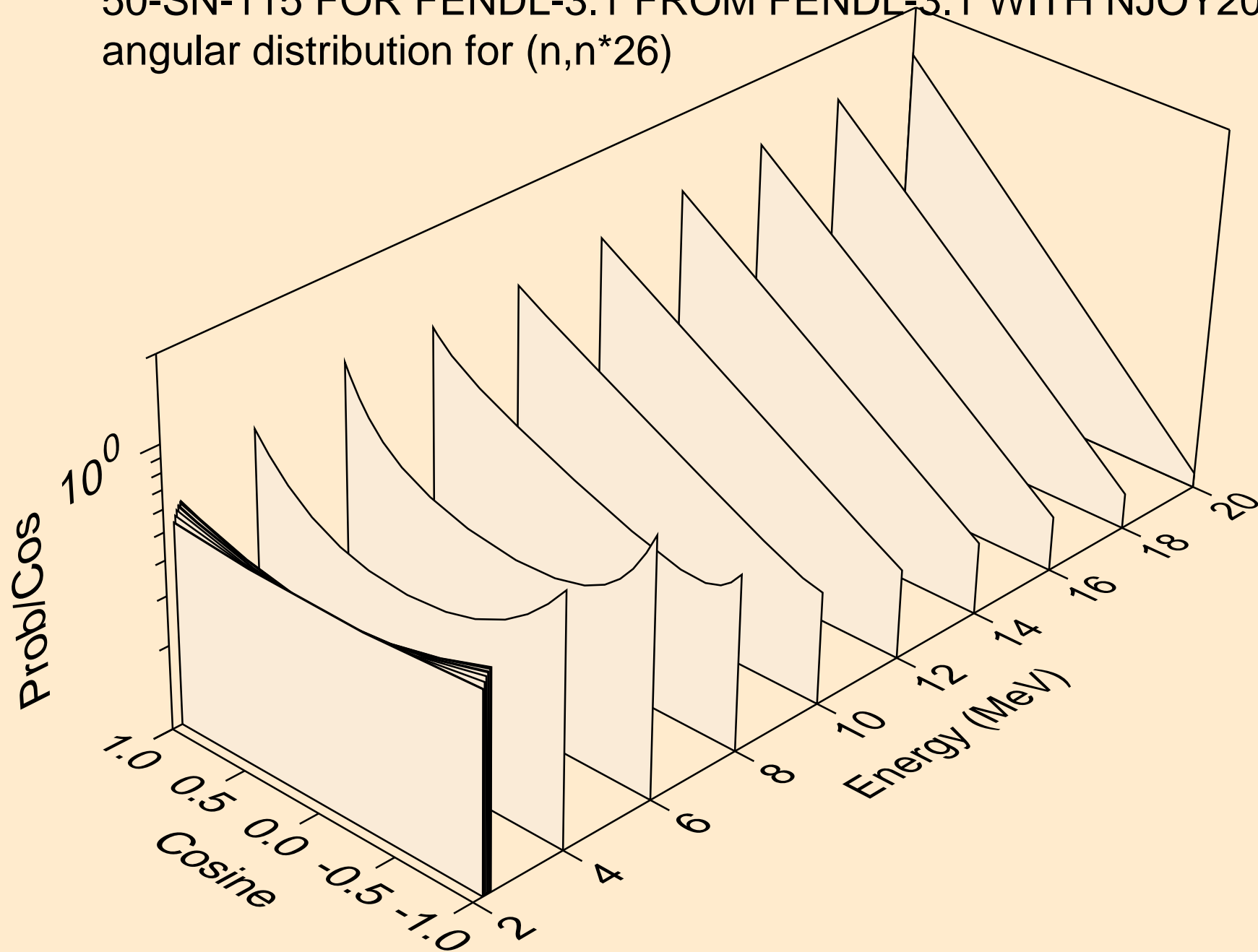

50-SN-115 FOR FENDL-3.1 FROM FENDL-3.1 WITH NJOY2012.50  
angular distribution for (n,n\*27)

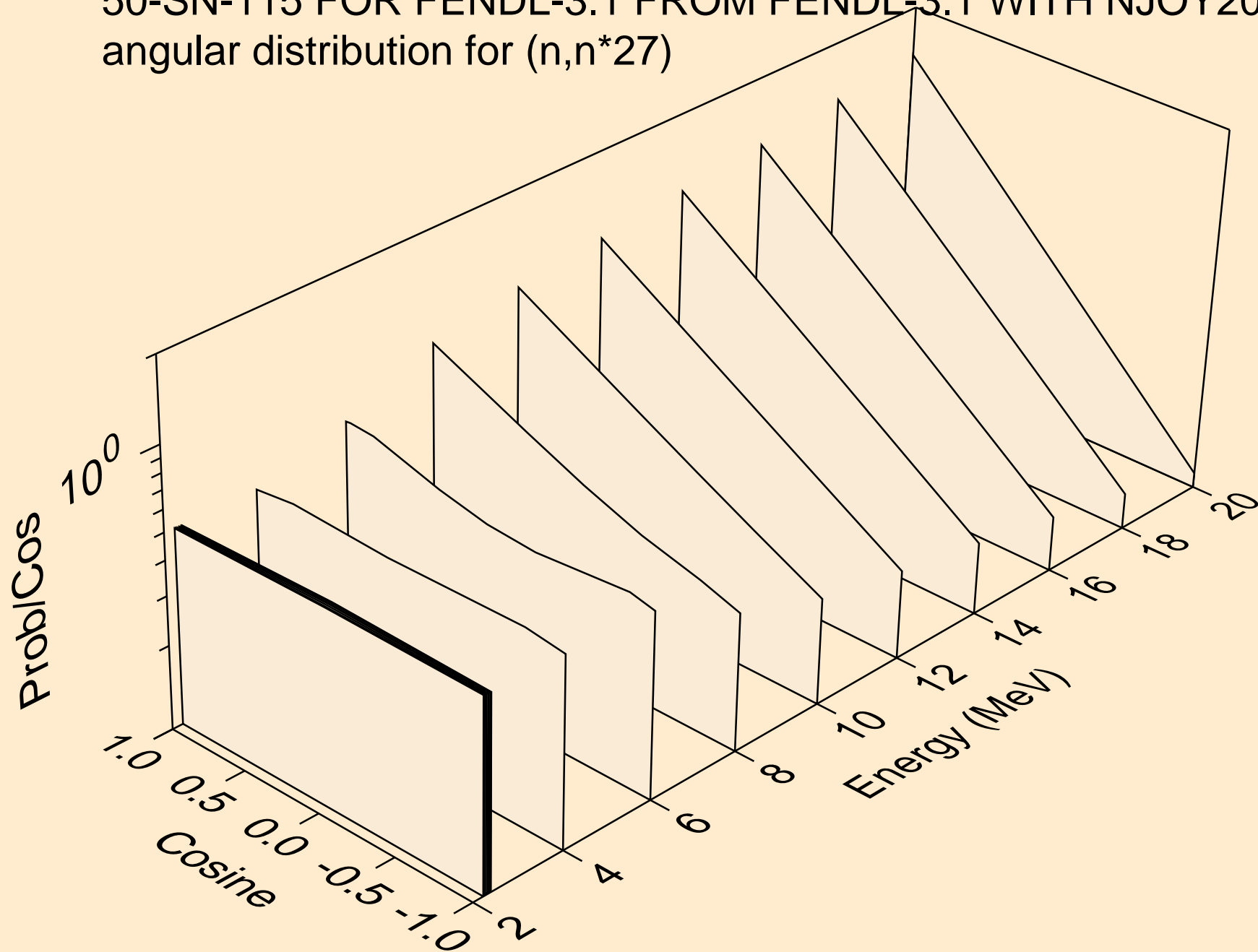

50-SN-115 FOR FENDL-3.1 FROM FENDL-3.1 WITH NJOY2012.50  
angular distribution for (n,n\*28)

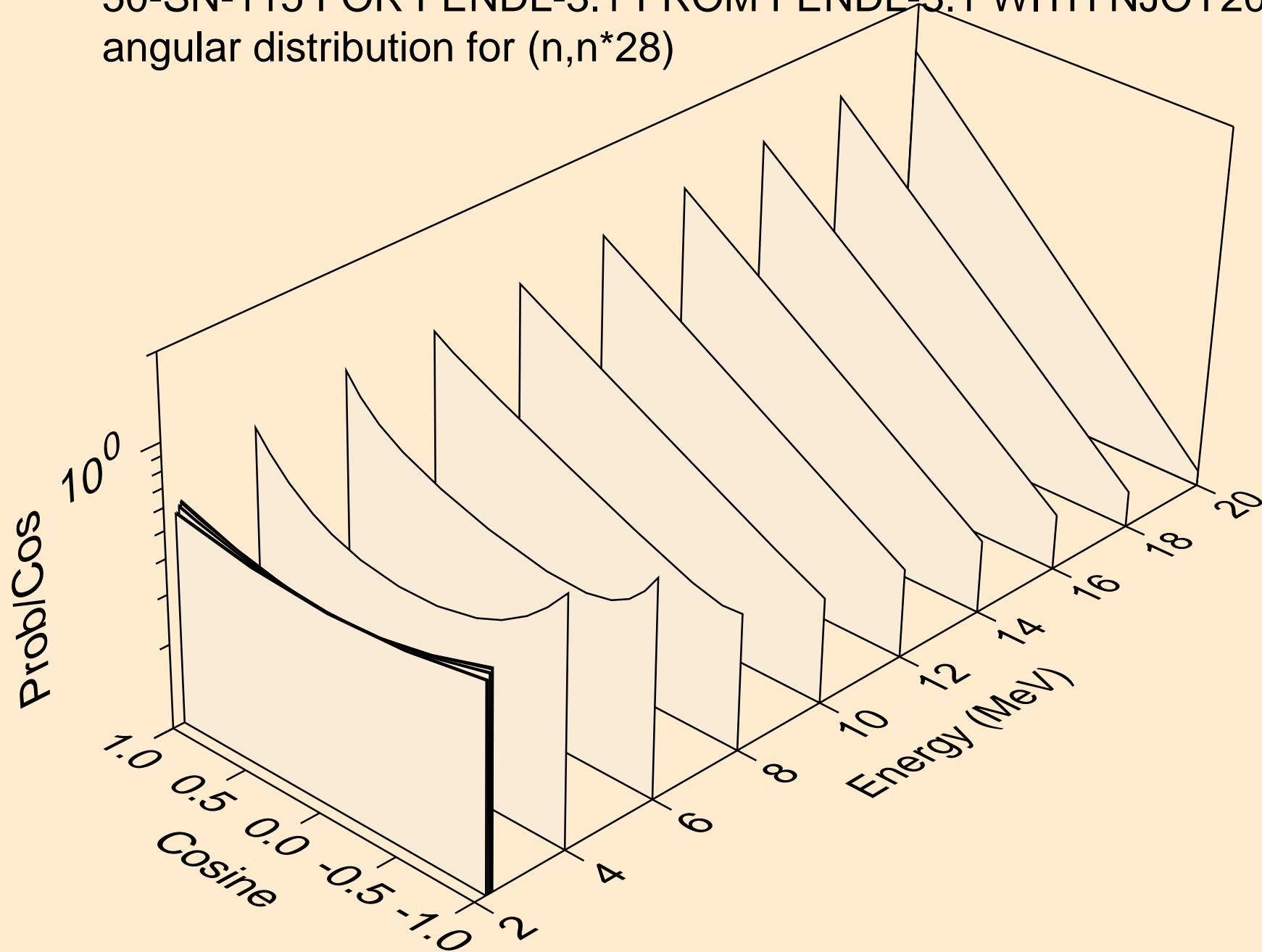



50-SN-115 FOR FENDL-3.1 FROM FENDL-3.1 WITH NJOY2012.50  
angular distribution for (n,n\*29)

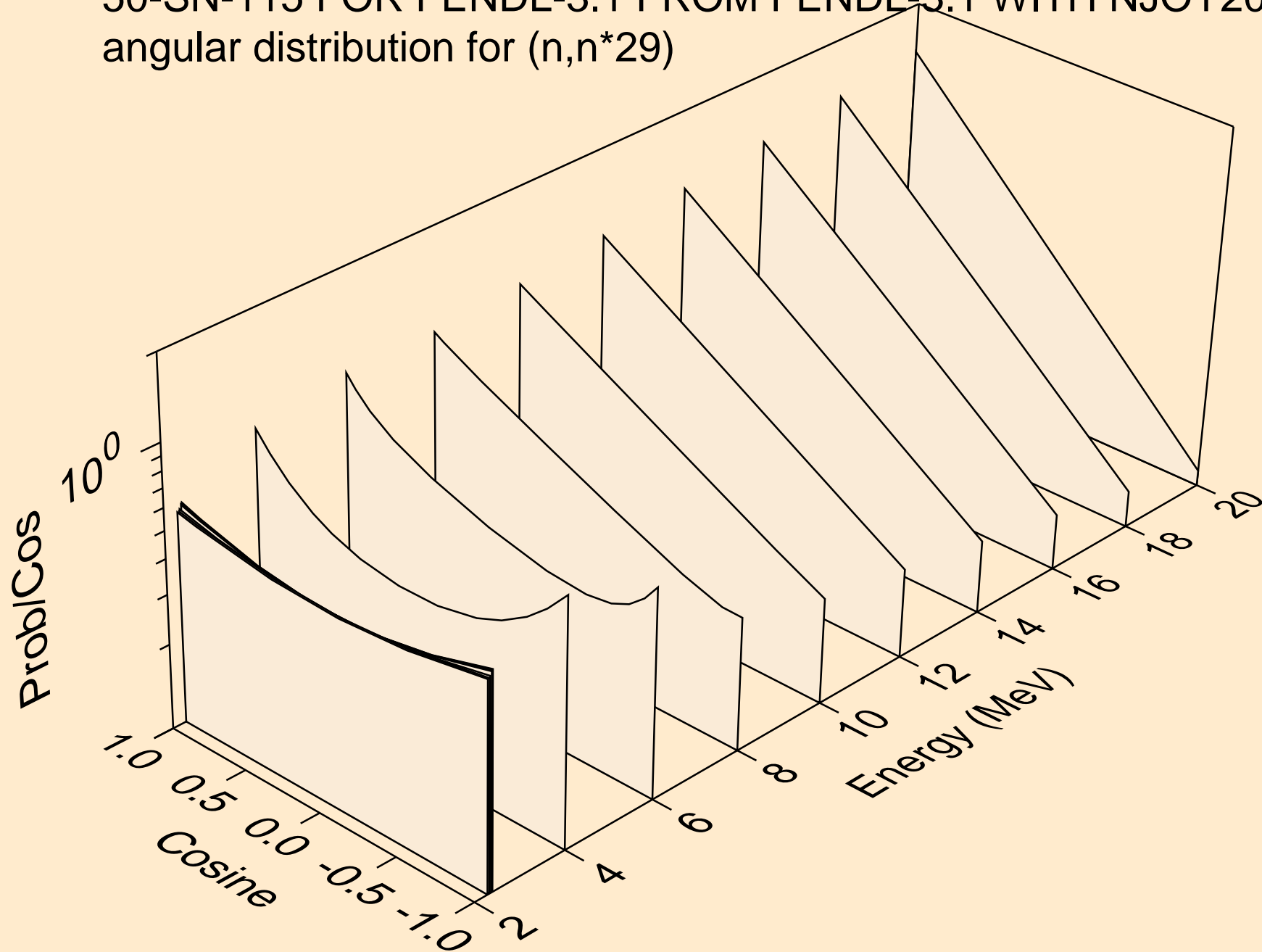

50-SN-115 FOR FENDL-3.1 FROM FENDL-3.1 WITH NJOY2012.50  
angular distribution for (n,n\*30)

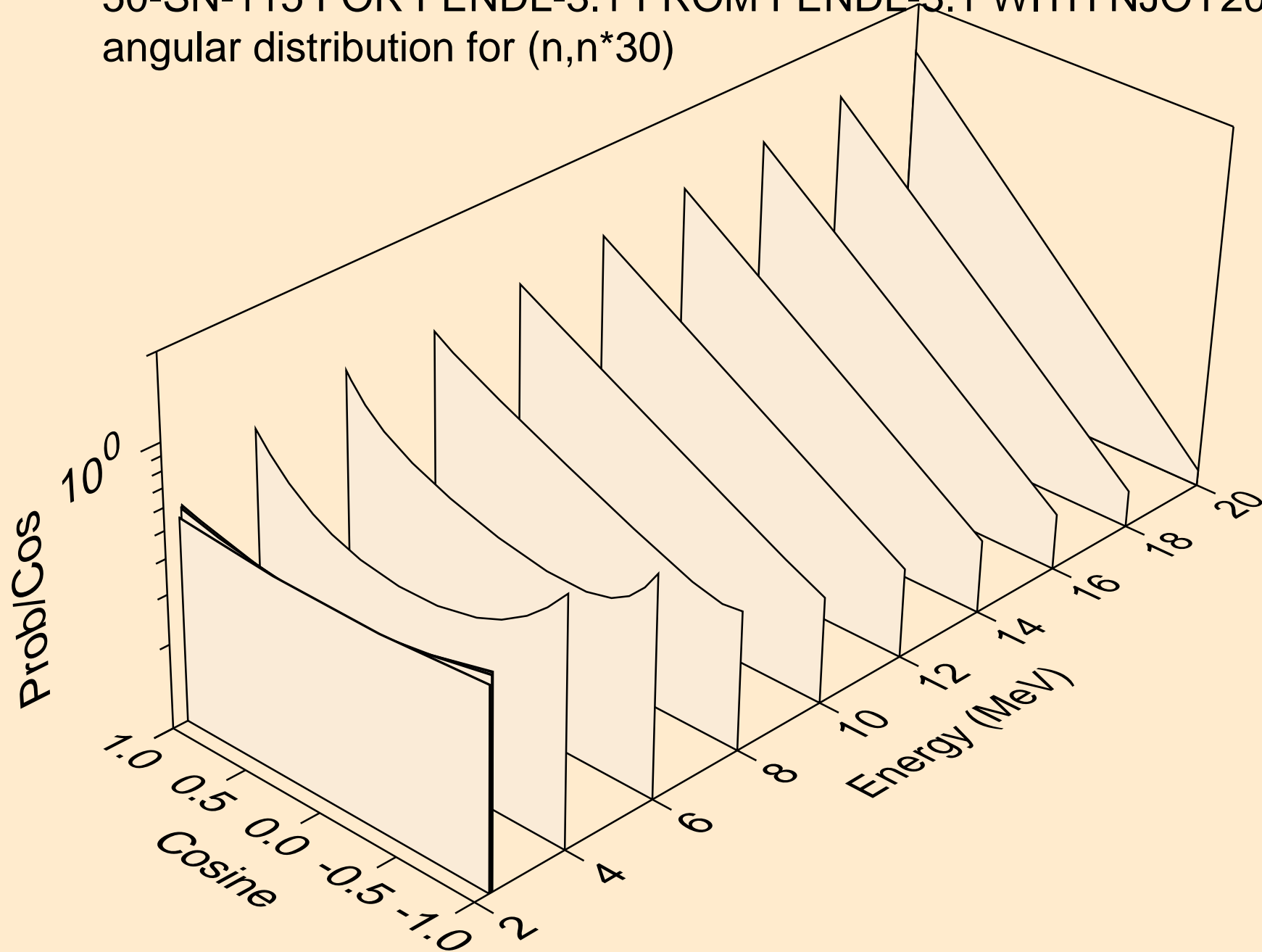

50-SN-115 FOR FENDL-3.1 FROM FENDL-3.1 WITH NJOY2012.50  
angular distribution for (n,n\*31)

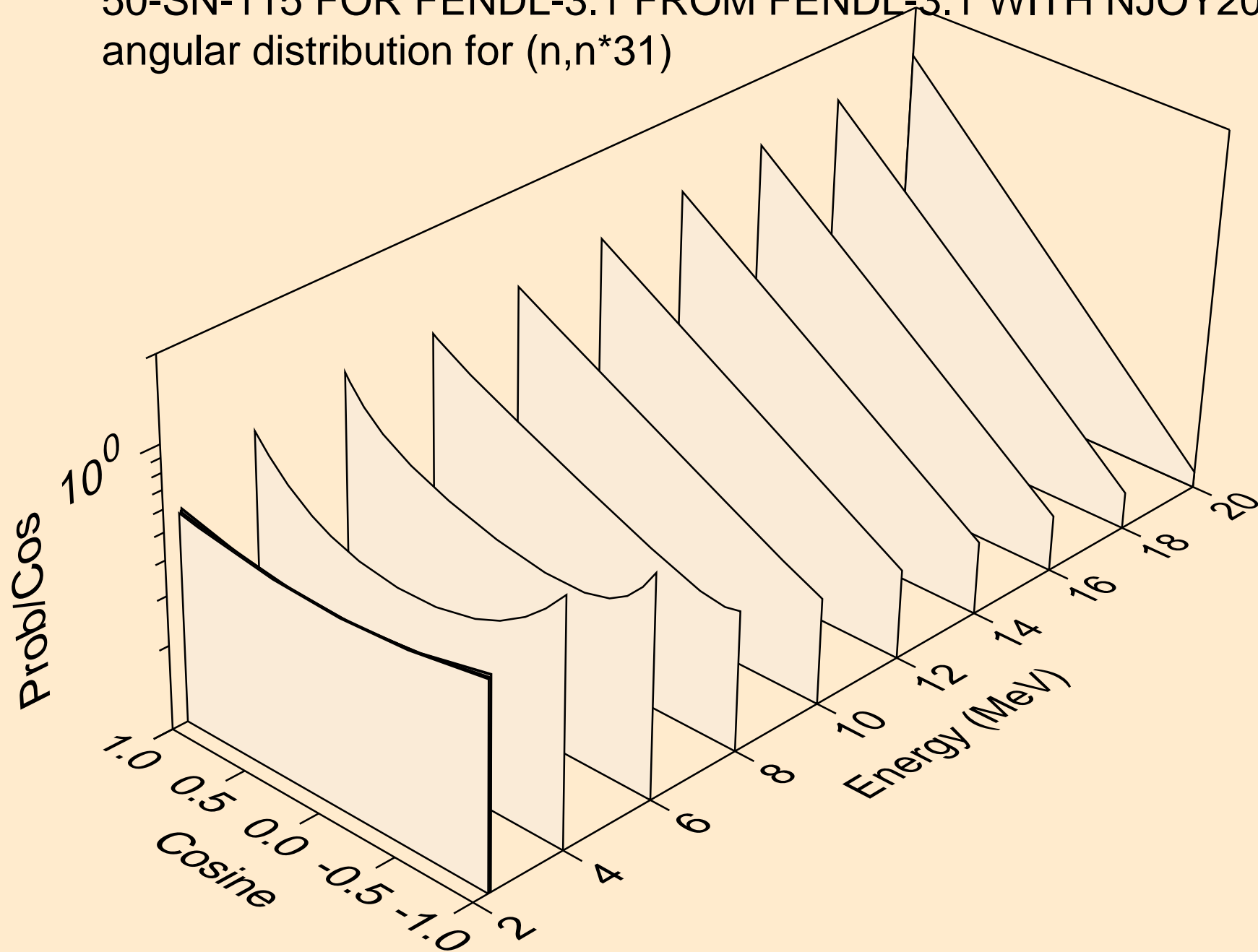

50-SN-115 FOR FENDL-3.1 FROM FENDL-3.1 WITH NJOY2012.50  
angular distribution for (n,n\*32)

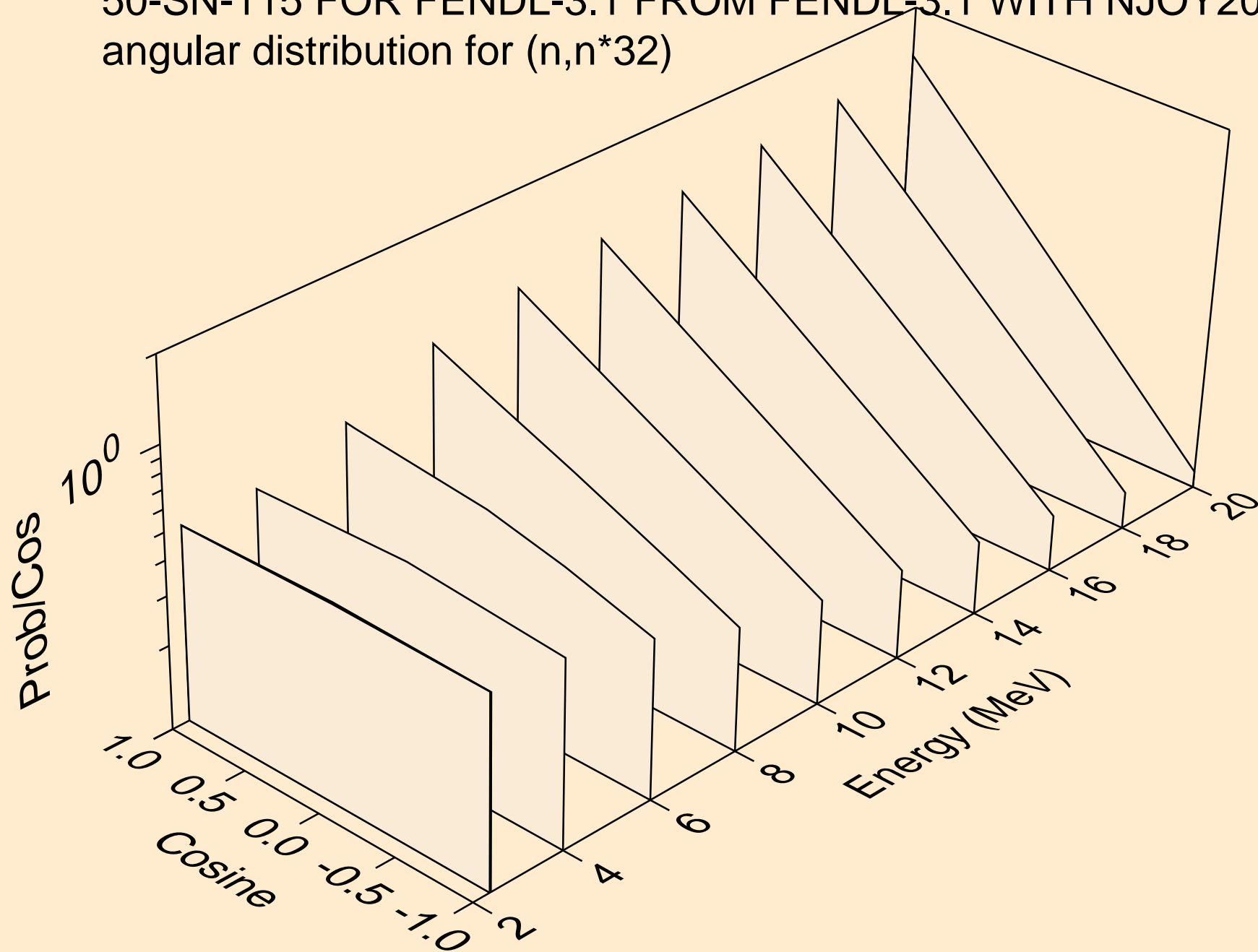

50-SN-115 FOR FENDL-3.1 FROM FENDL-3.1 WITH NJOY2012.50  
angular distribution for (n,n\*33)

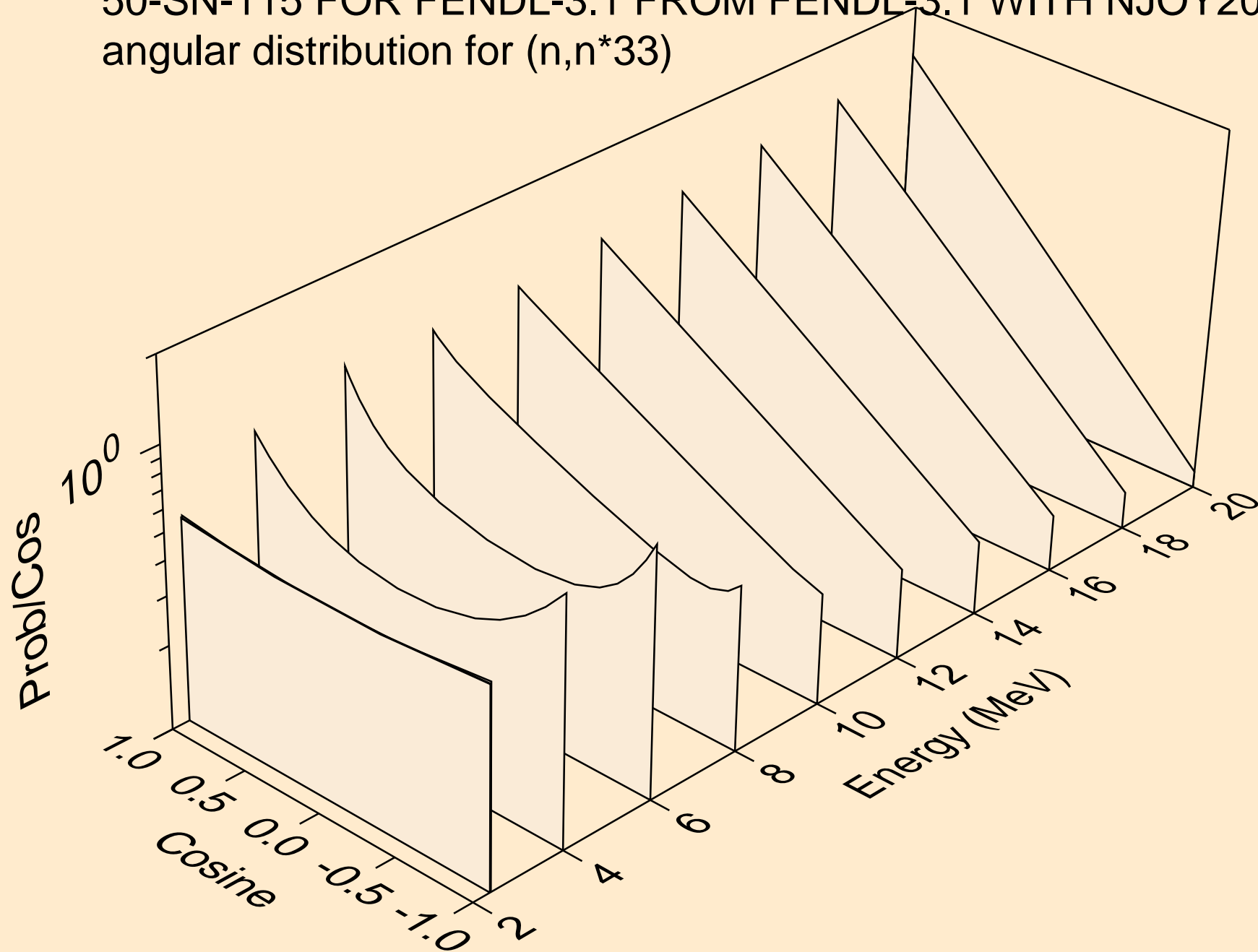

50-SN-115 FOR FENDL-3.1 FROM FENDL-3.1 WITH NJOY2012.50  
angular distribution for (n,n\*34)

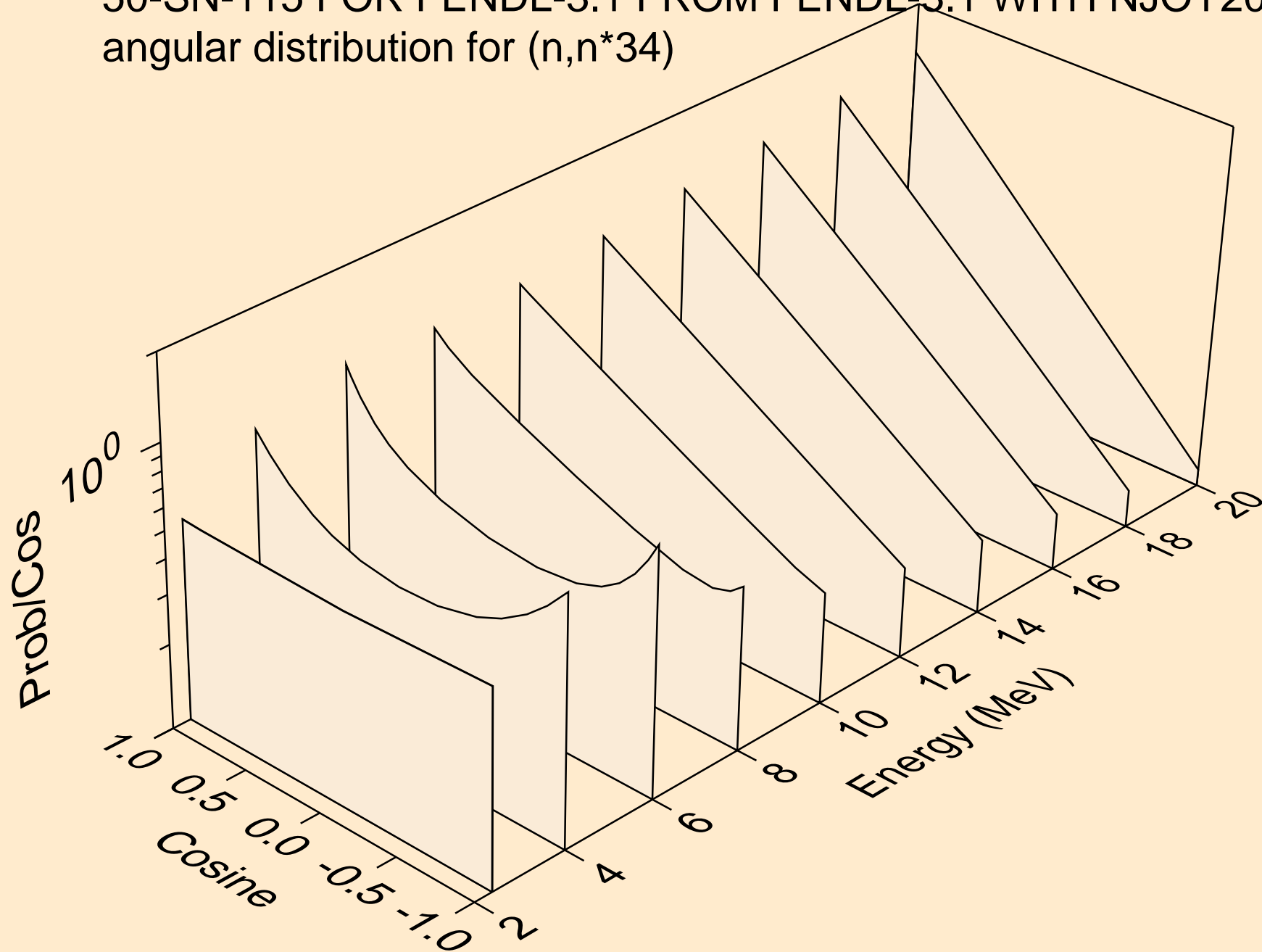

50-SN-115 FOR FENDL-3.1 FROM FENDL-3.1 WITH NJOY2012.50  
angular distribution for (n,n\*35)

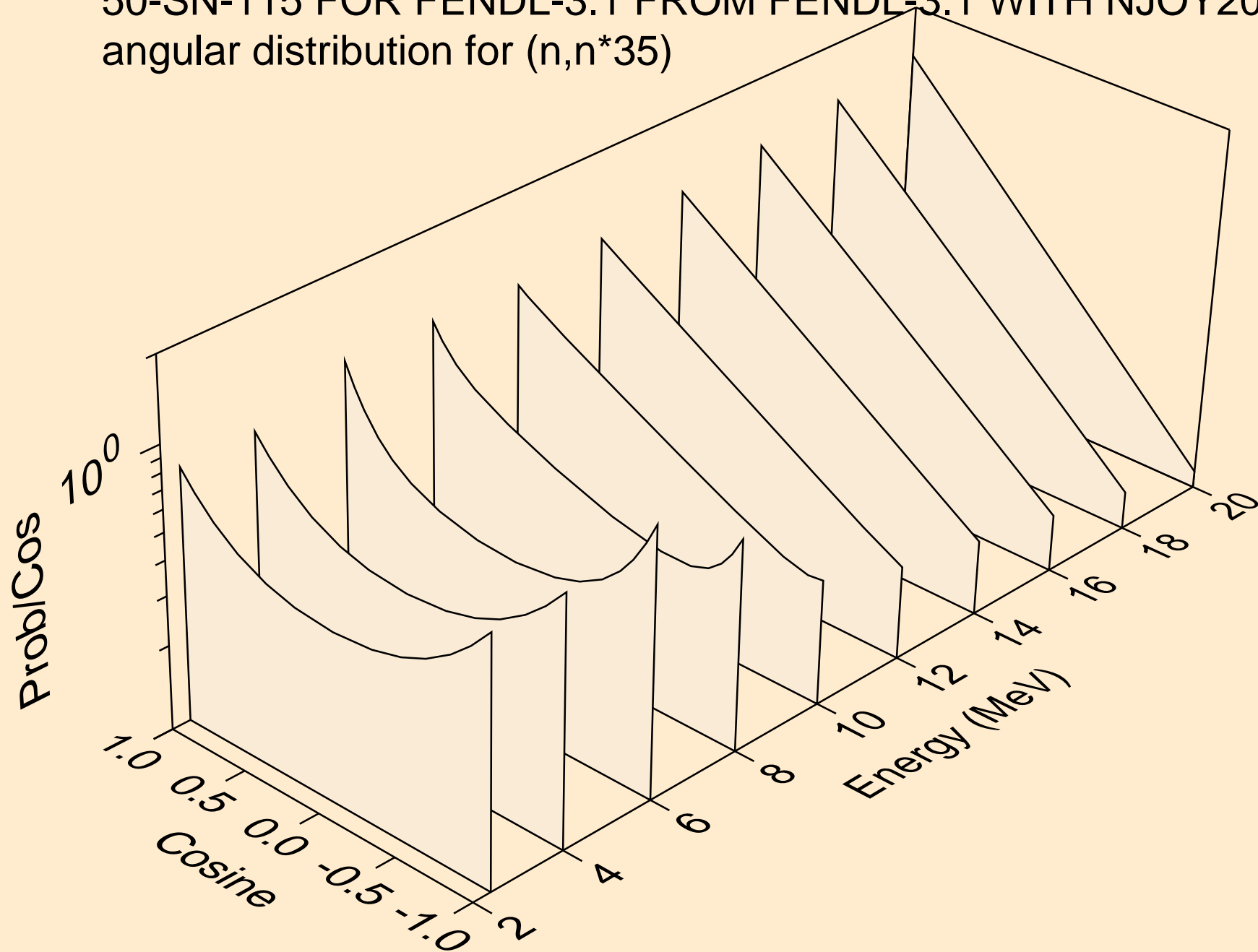

50-SN-115 FOR FENDL-3.1 FROM FENDL-3.1 WITH NJOY2012.50  
Neutron emission for (n,x)

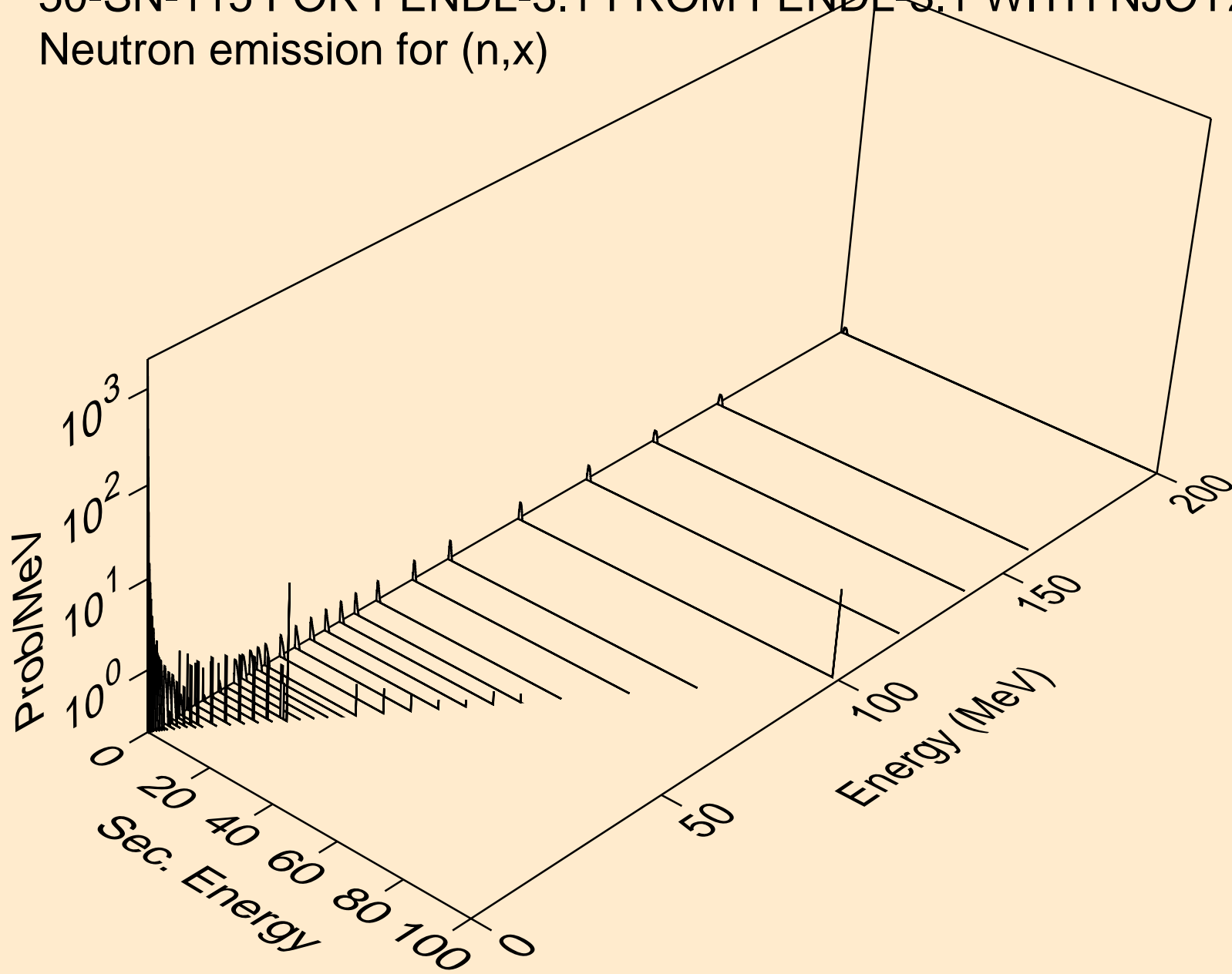



50-SN-115 FOR FENDL-3.1 FROM FENDL-3.1 WITH NJOY2012.50  
Neutron emission for (n,2n)

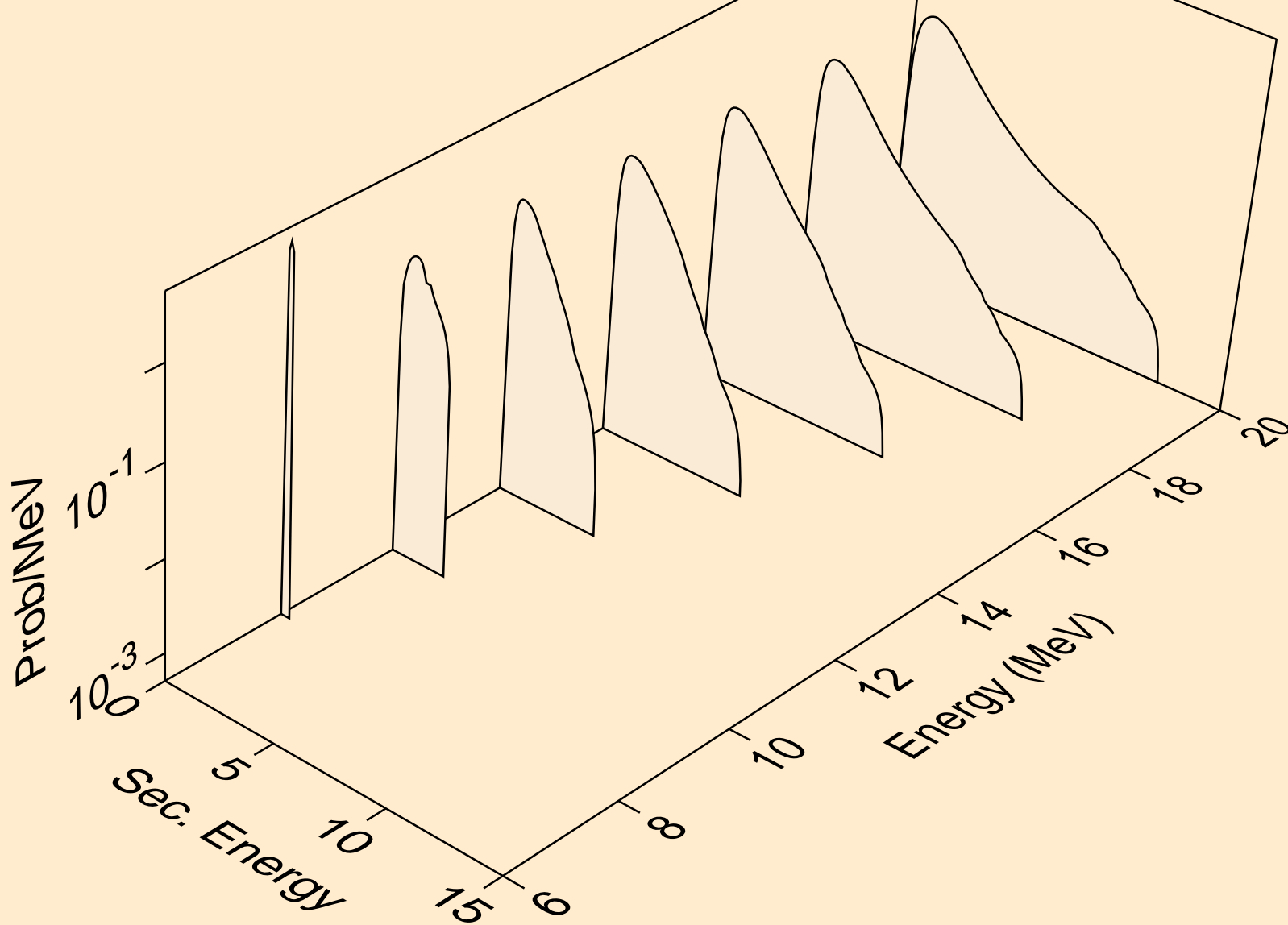

50-SN-115 FOR FENDL-3.1 FROM FENDL-3.1 WITH NJOY2012.50  
Neutron emission for (n,3n)

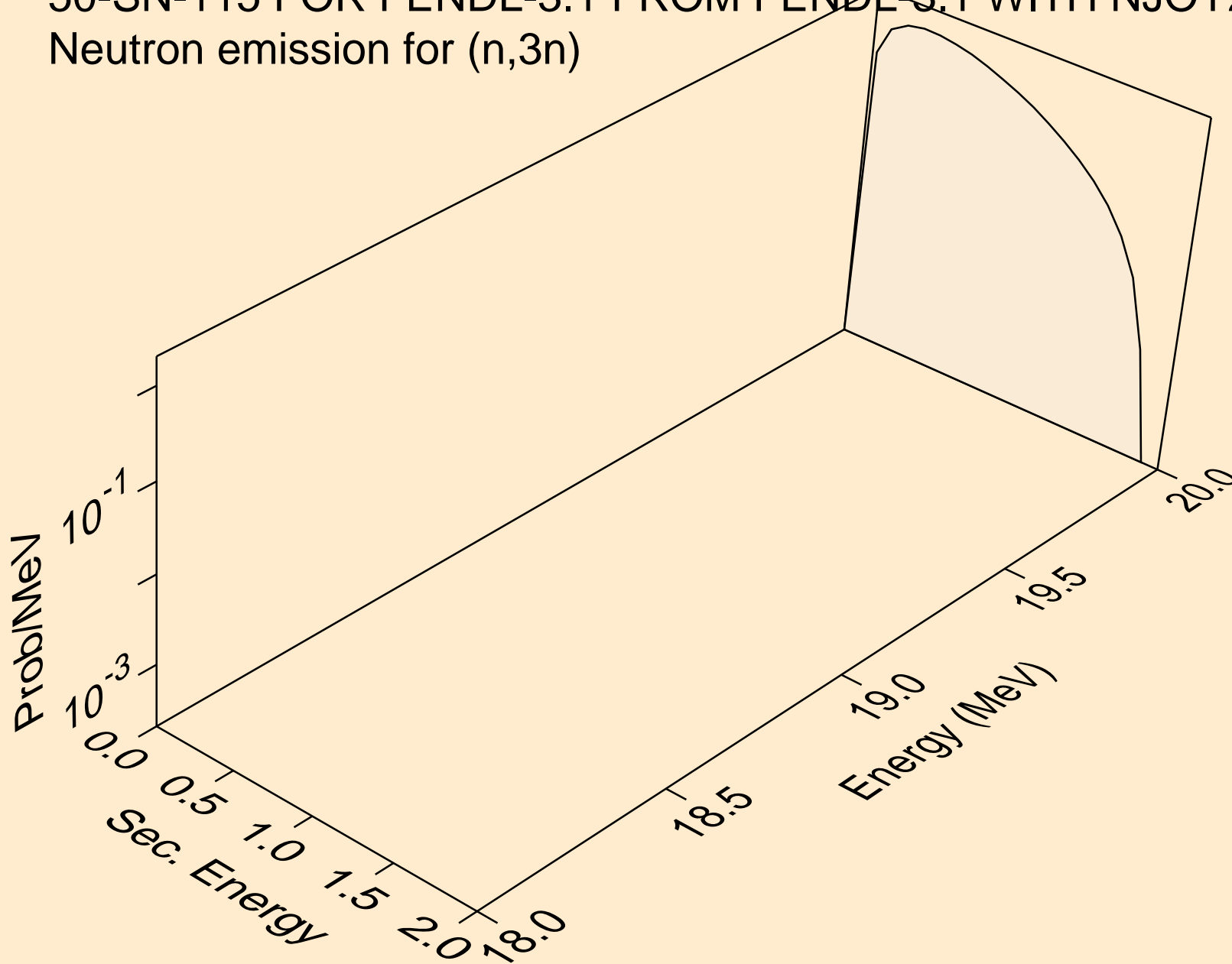

50-SN-115 FOR FENDL-3.1 FROM FENDL-3.1 WITH NJOY2012.50  
Neutron emission for (n,n\*)a

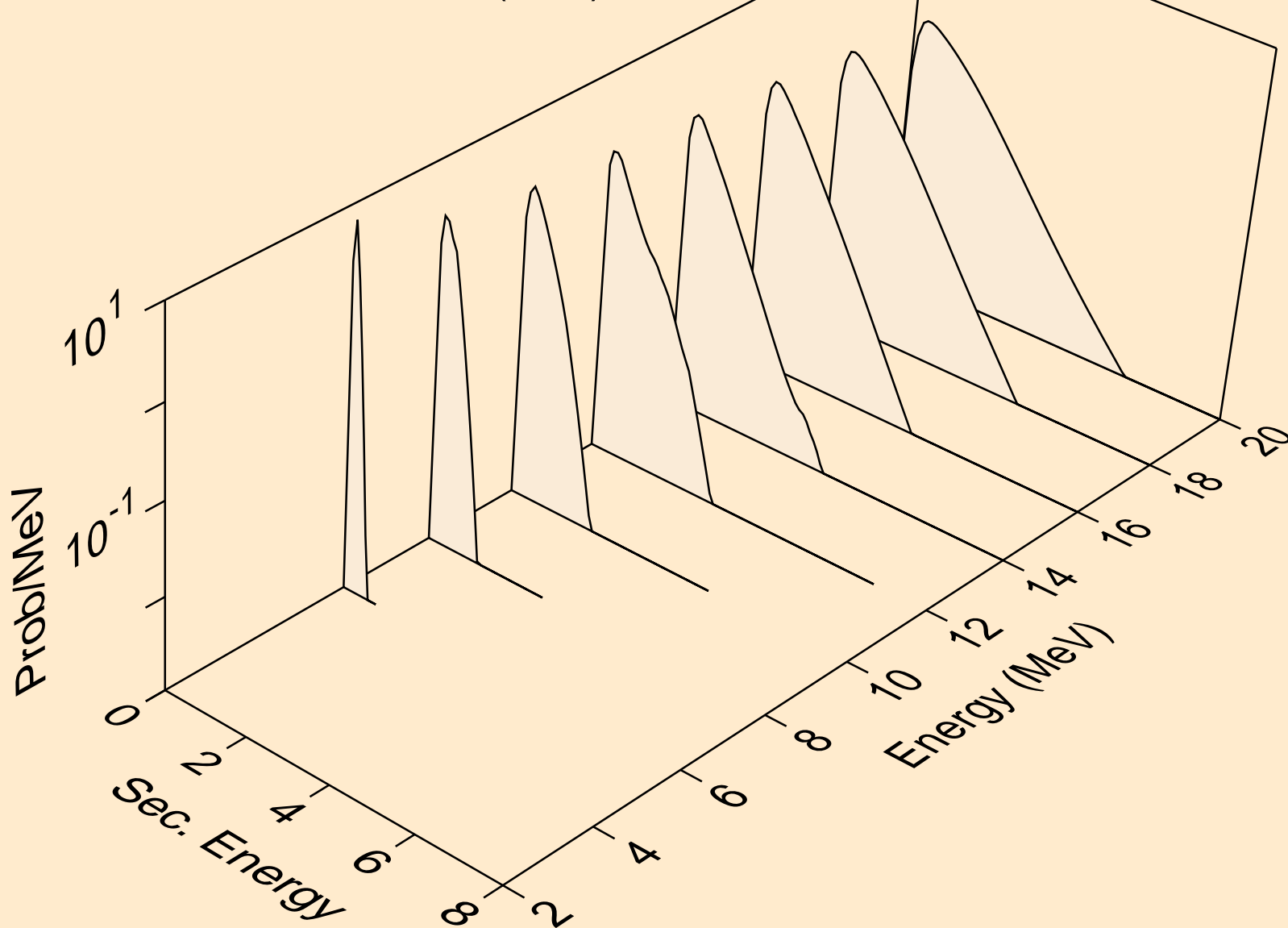

50-SN-115 FOR FENDL-3.1 FROM FENDL-3.1 WITH NJOY2012.50  
Neutron emission for (n,2n)a

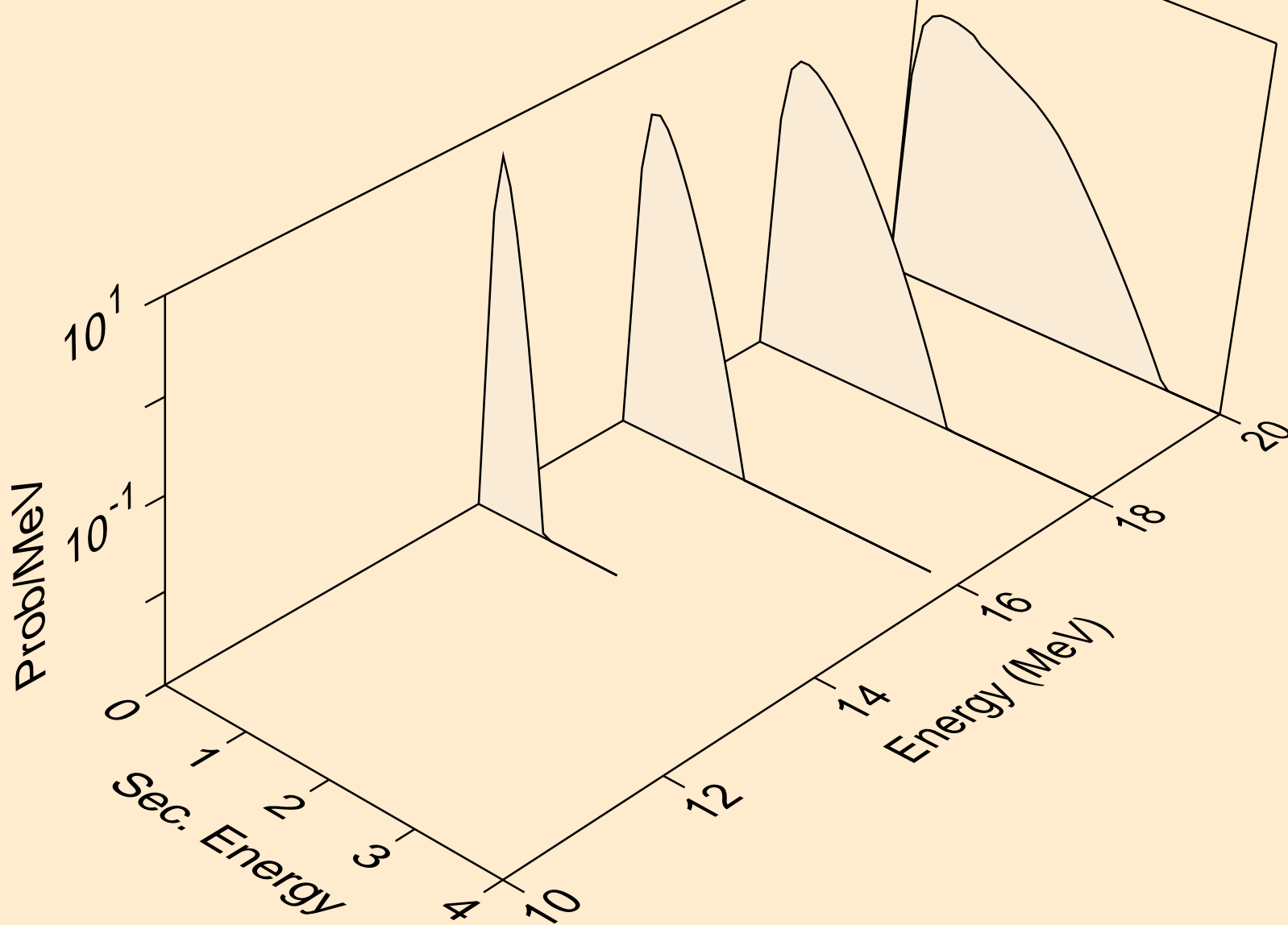

50-SN-115 FOR FENDL-3.1 FROM FENDL-3.1 WITH NJOY2012.50  
Neutron emission for (n,n\*)p

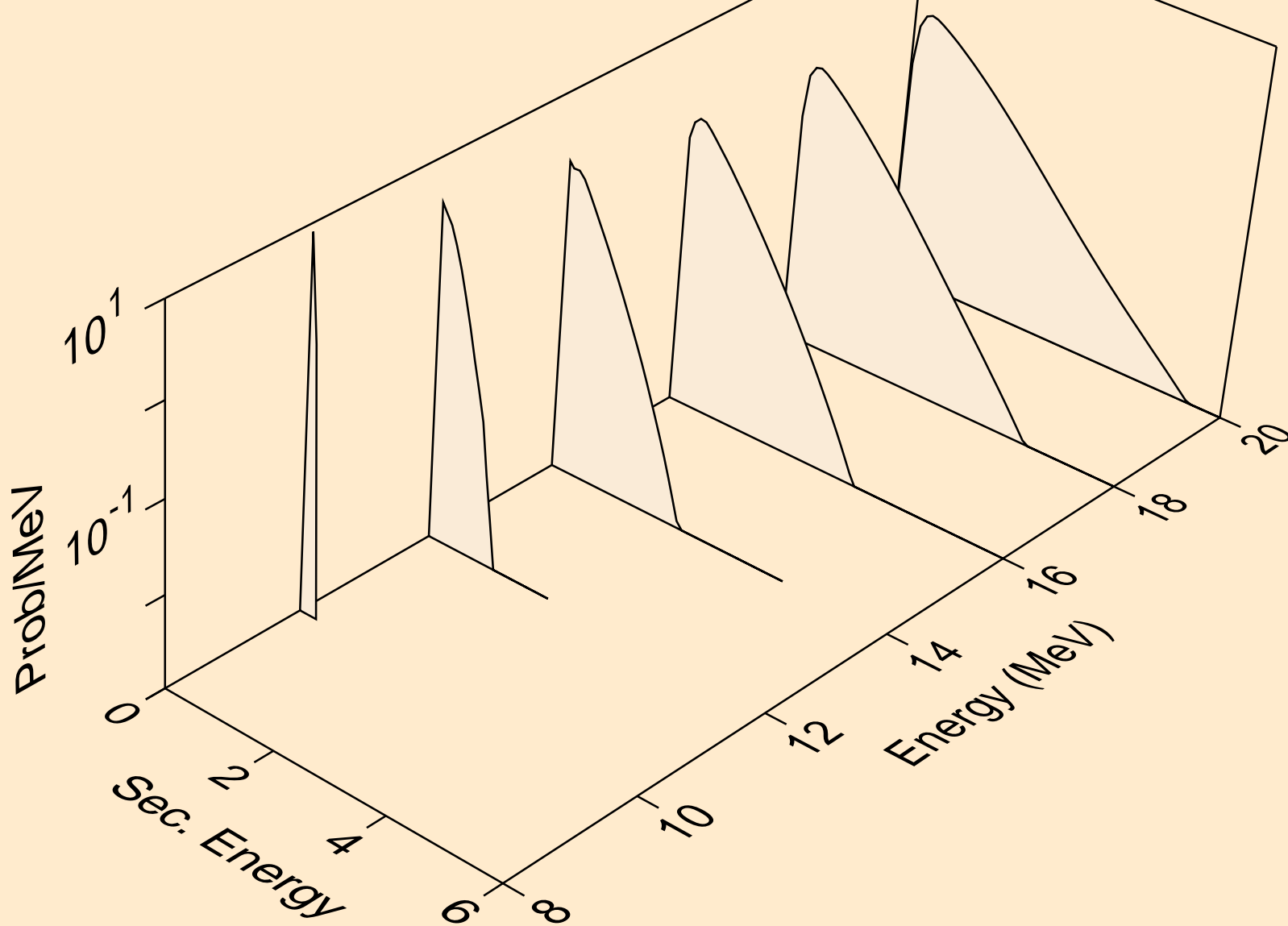

50-SN-115 FOR FENDL-3.1 FROM FENDL-3.1 WITH NJOY2012.50  
Neutron emission for (n,n\*)d

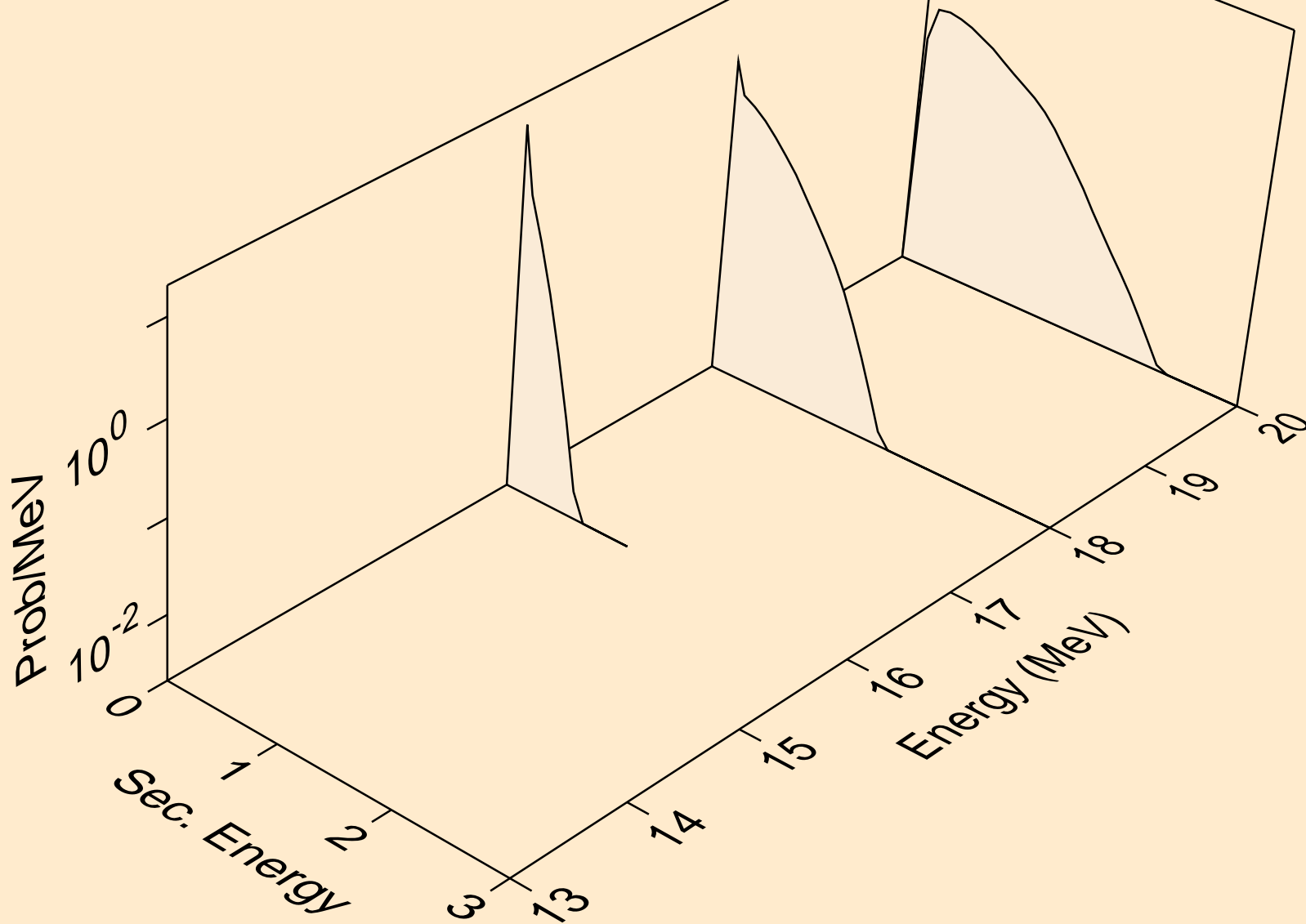

50-SN-115 FOR FENDL-3.1 FROM FENDL-3.1 WITH NJOY2012.50  
Neutron emission for (n,2np)

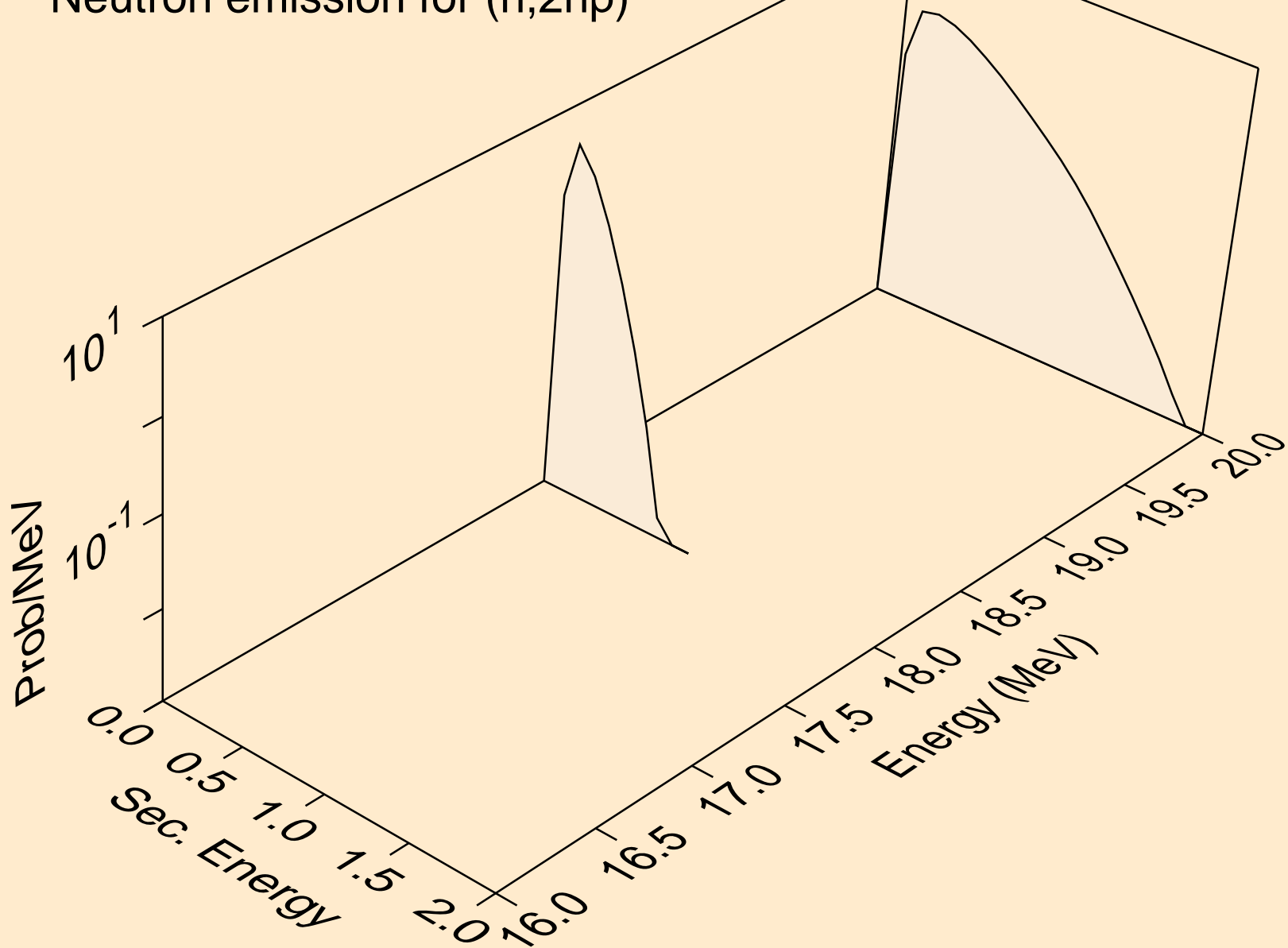

50-SN-115 FOR FENDL-3.1 FROM FENDL-3.1 WITH NJOY2012.50  
Neutron emission for (n,n\*c)

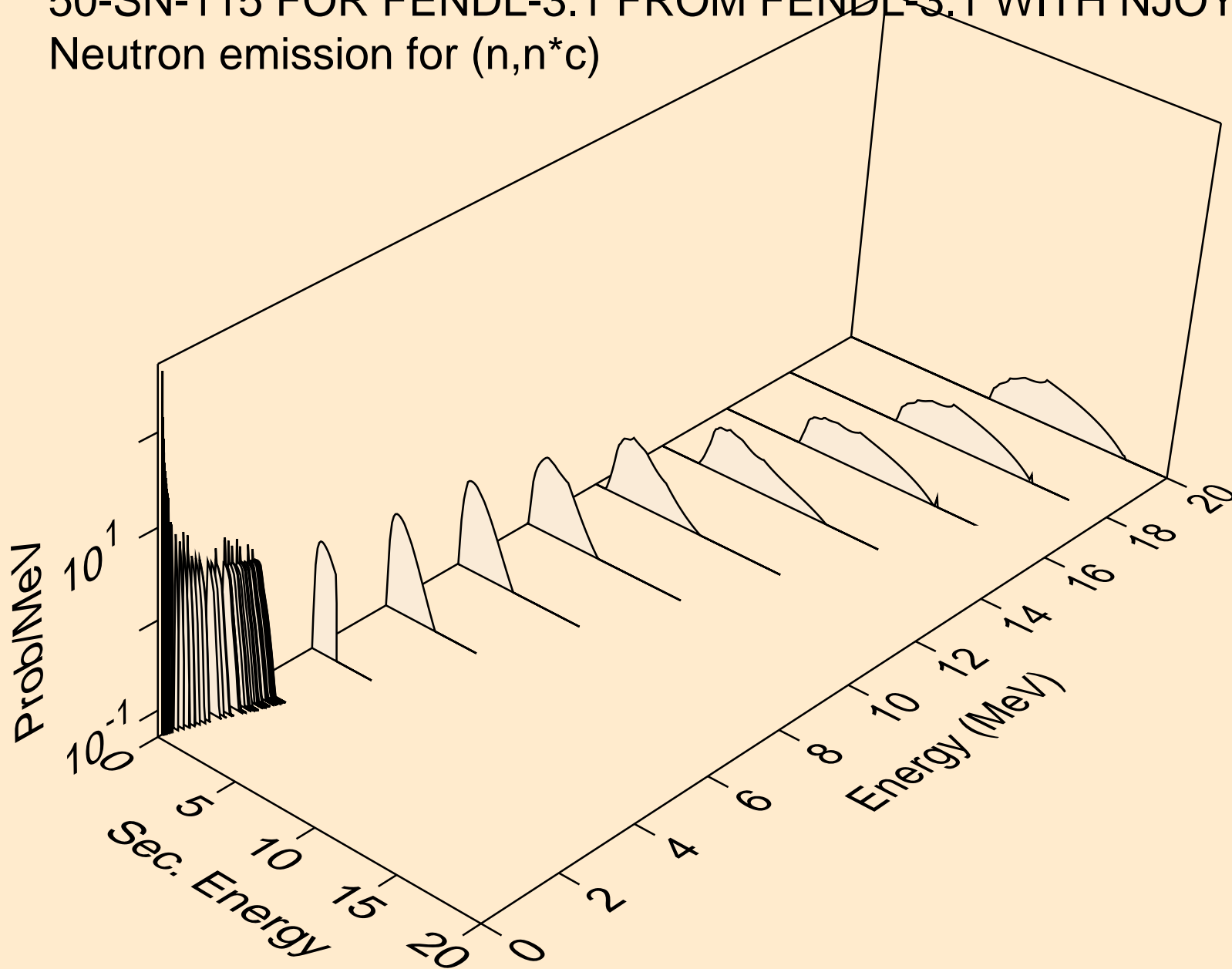



50-SN-115 FOR FENDL-3.1 FROM FENDL-3.1 WITH NJOY2012.50  
Photon emission for (n,x)

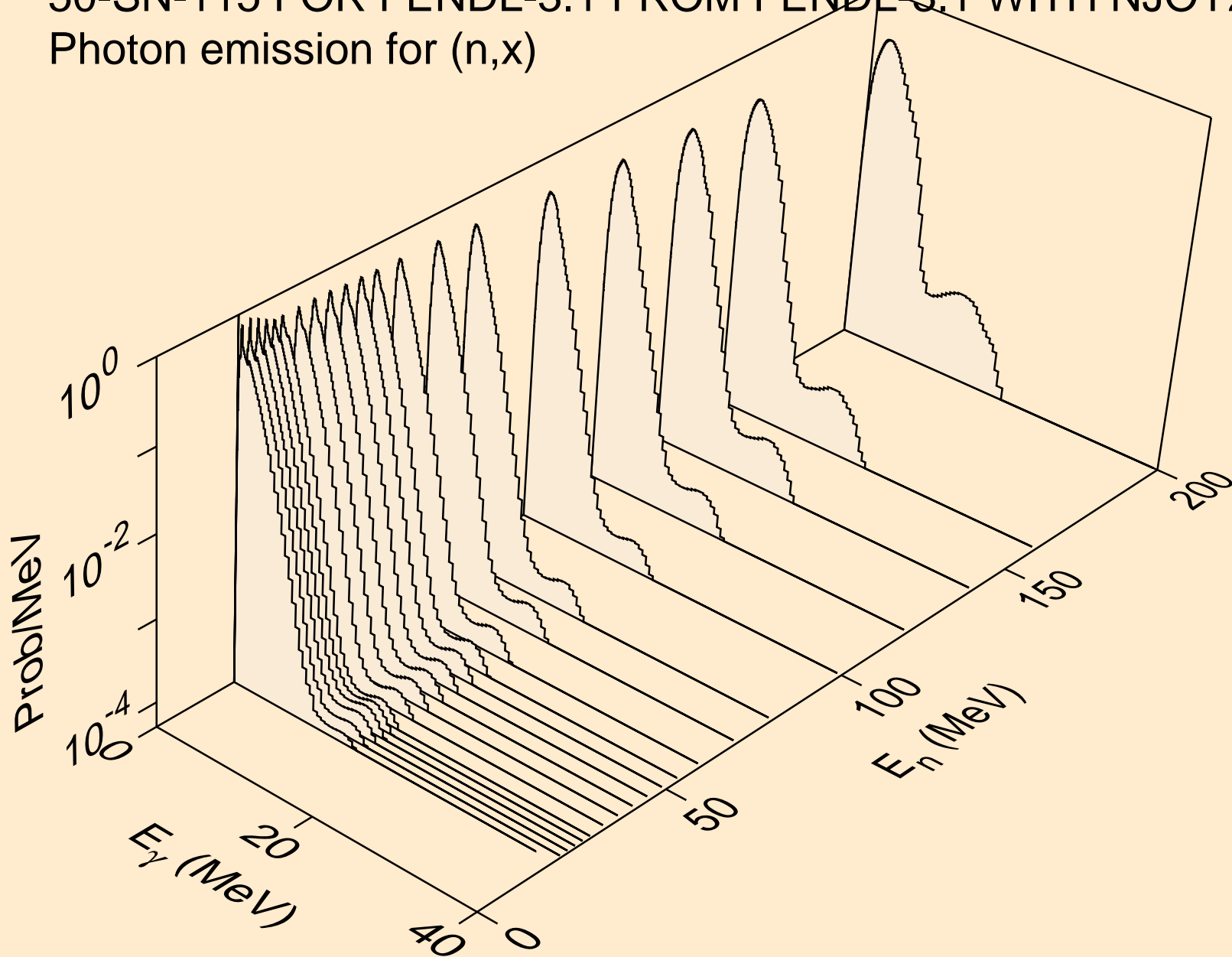

50-SN-115 FOR FENDL-3.1 FROM FENDL-3.1 WITH NJOY2012.50  
Photon emission for (n,2n)

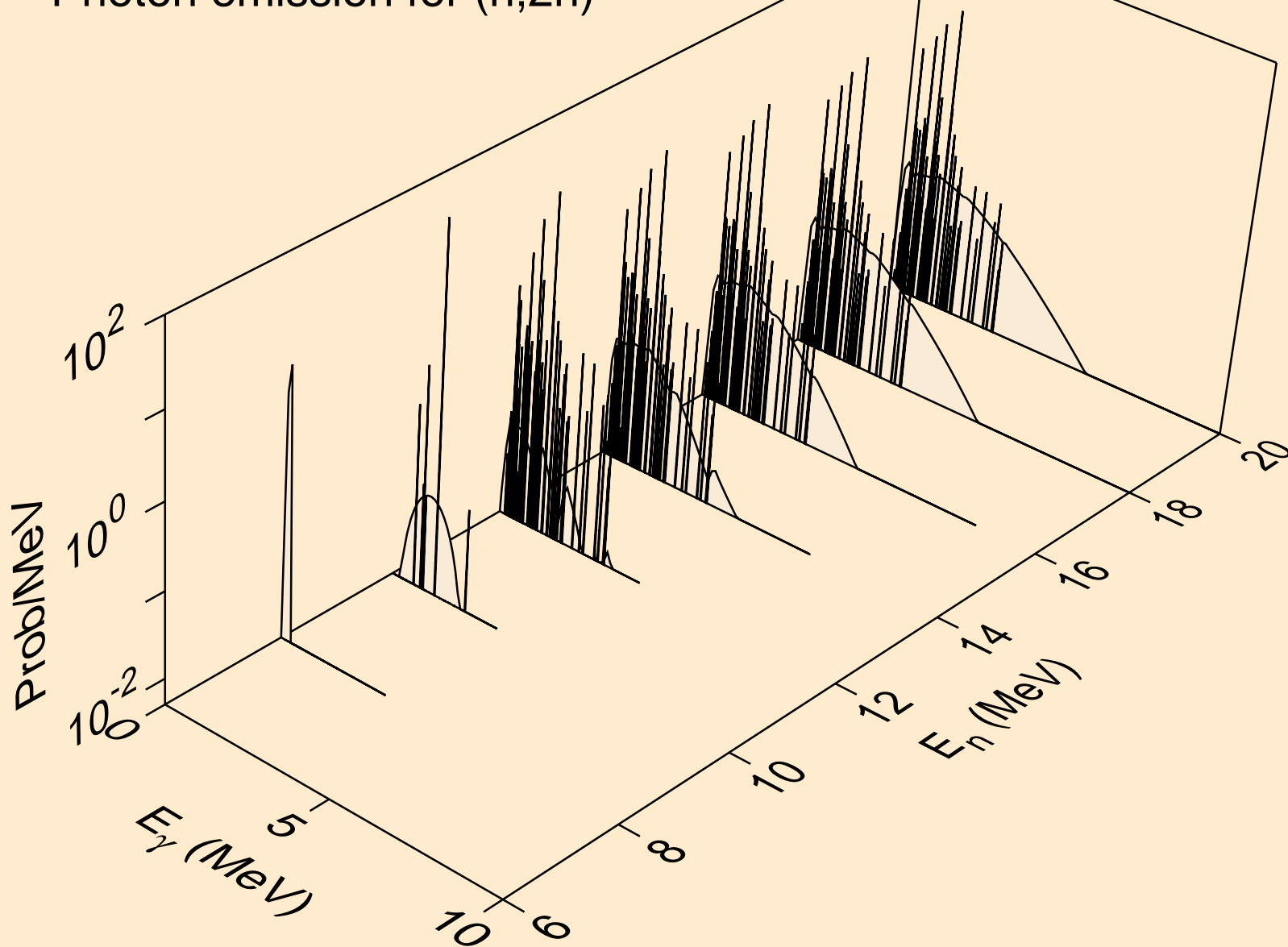

50-SN-115 FOR FENDL-3.1 FROM FENDL-3.1 WITH NJOY2012.50  
Photon emission for (n,3n)

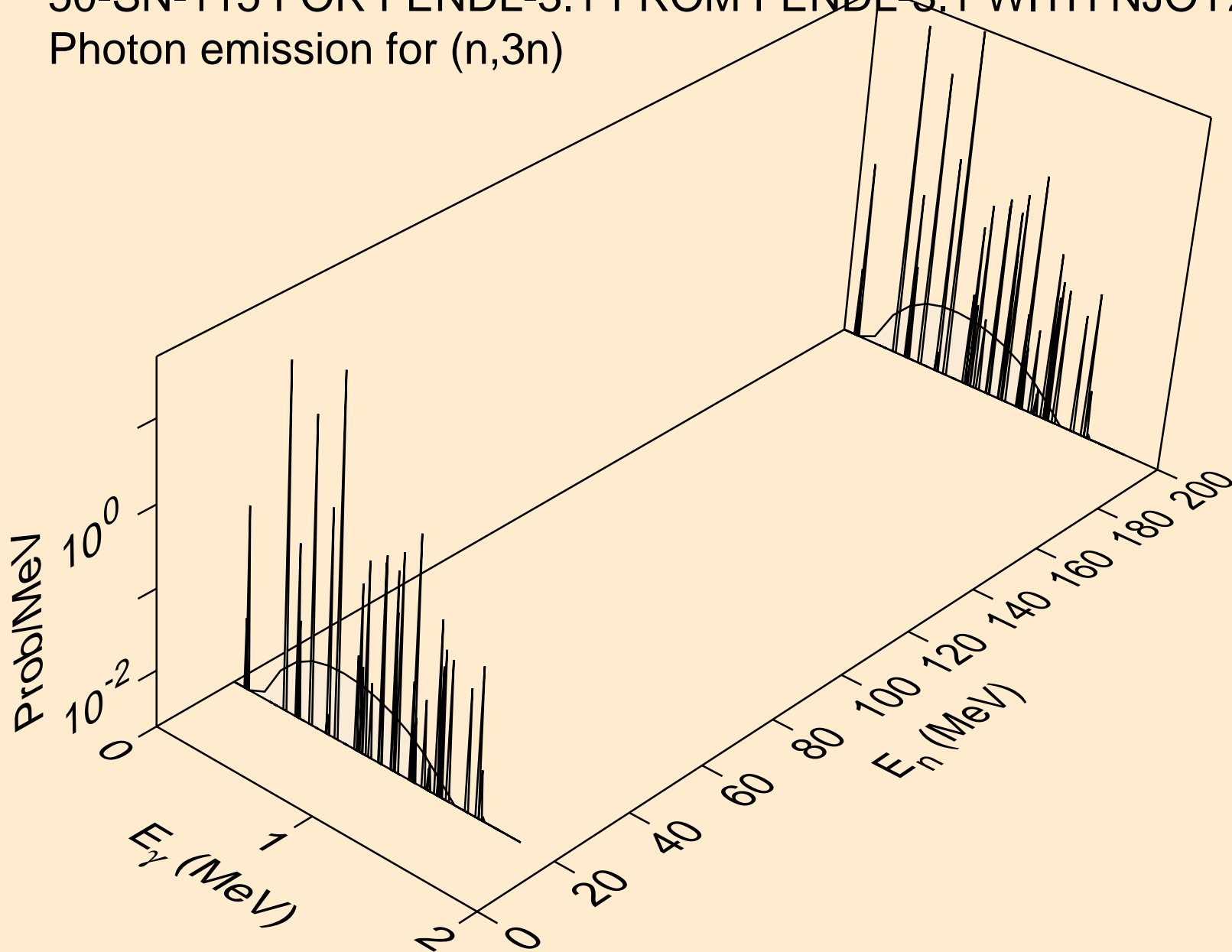

50-SN-115 FOR FENDL-3.1 FROM FENDL-3.1 WITH NJOY2012.50  
Photon emission for (n,n\*)a

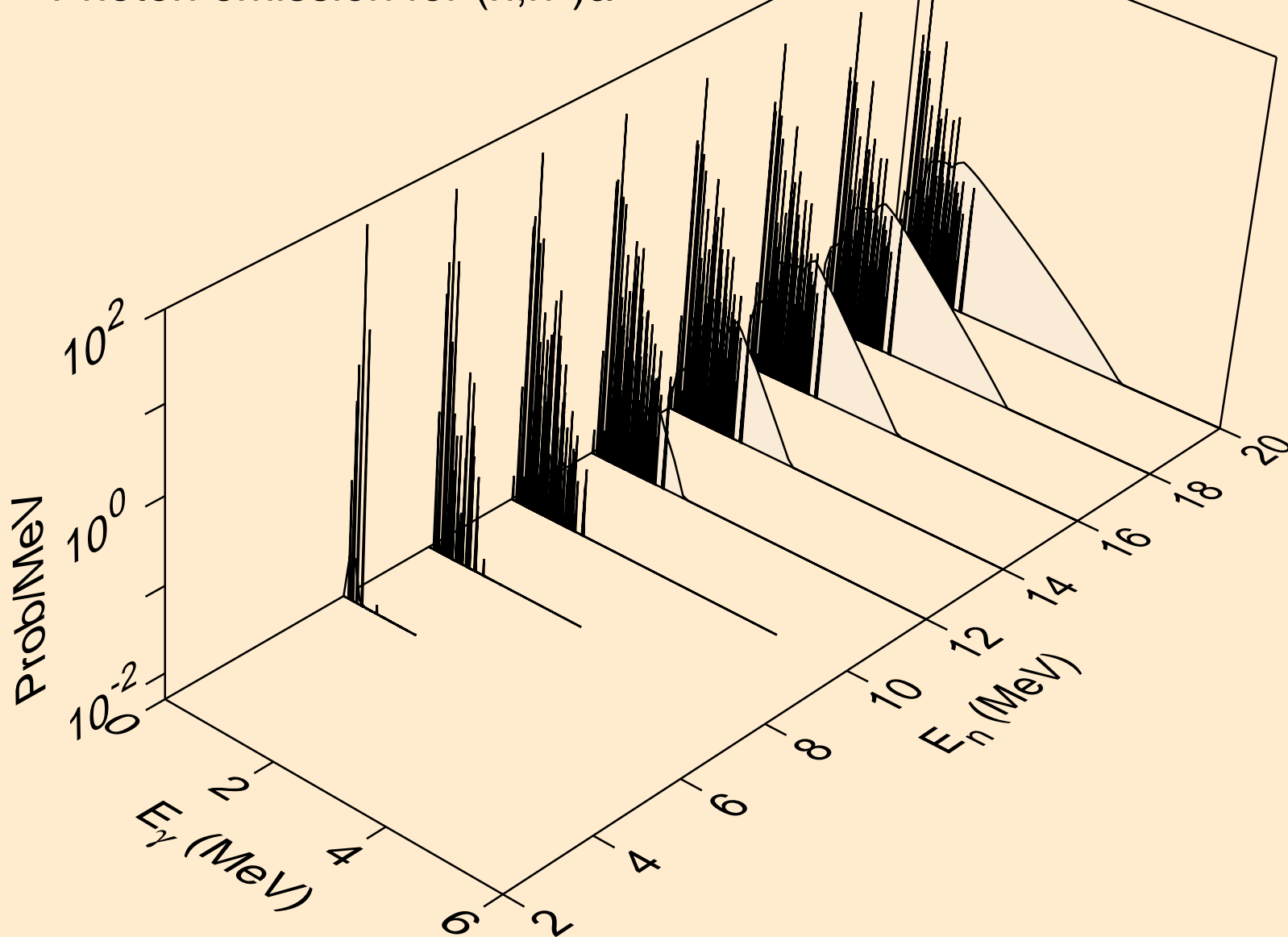

50-SN-115 FOR FENDL-3.1 FROM FENDL-3.1 WITH NJOY2012.50  
Photon emission for (n,2n)a

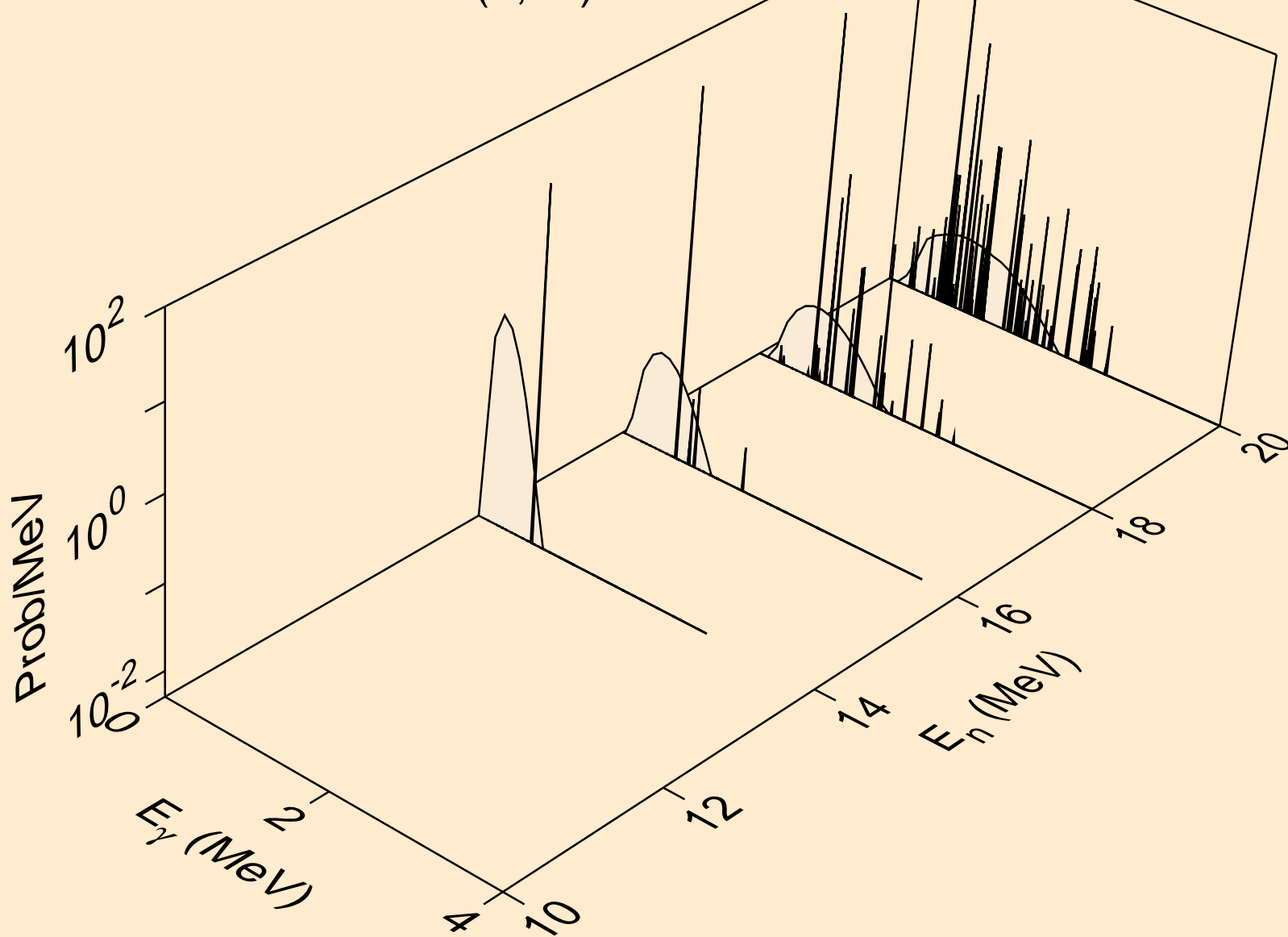

50-SN-115 FOR FENDL-3.1 FROM FENDL-3.1 WITH NJOY2012.50  
Photon emission for (n,n\*)p

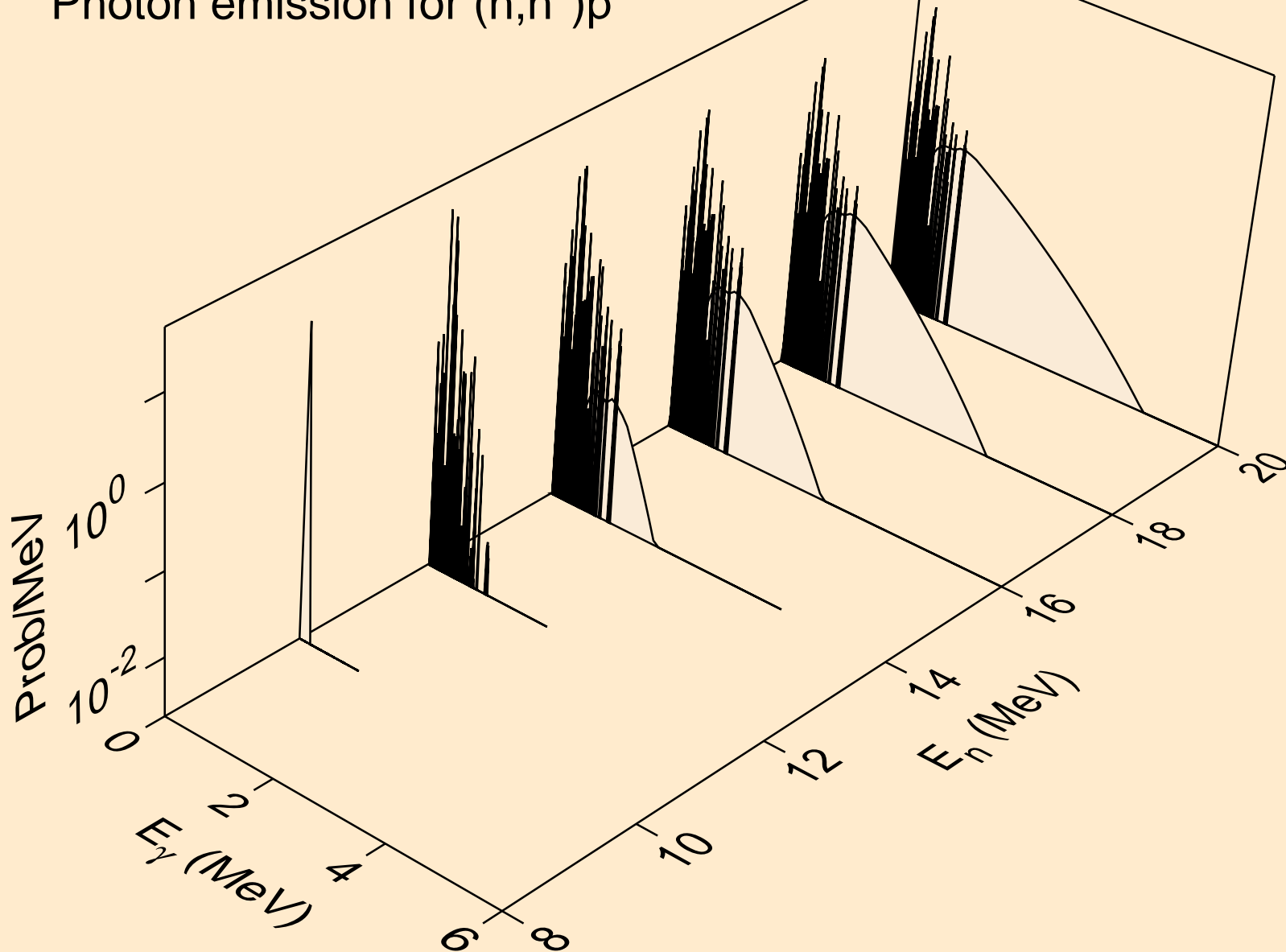

50-SN-115 FOR FENDL-3.1 FROM FENDL-3.1 WITH NJOY2012.50  
Photon emission for (n,n\*)d

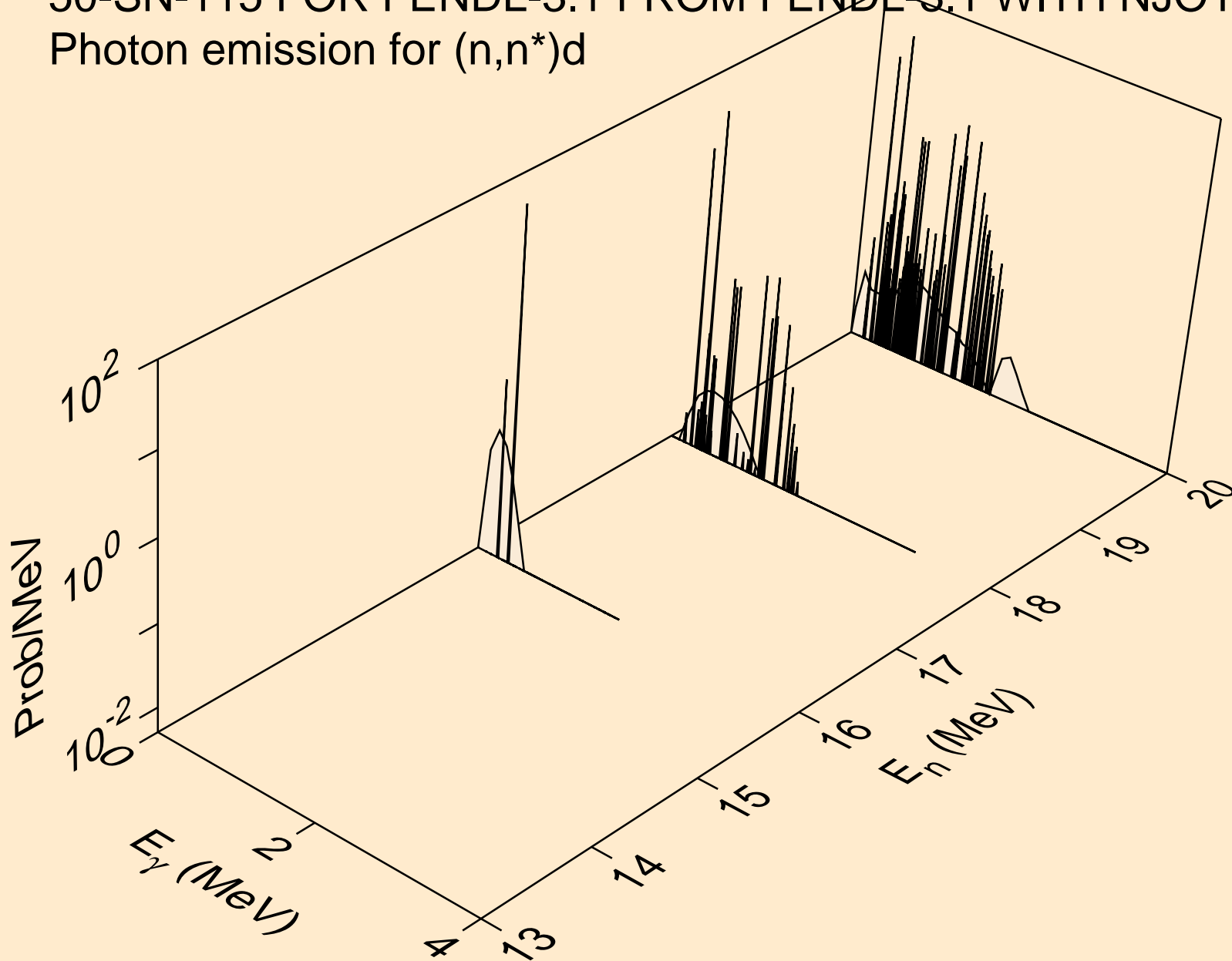

50-SN-115 FOR FENDL-3.1 FROM FENDL-3.1 WITH NJOY2012.50  
Photon emission for (n,2np)

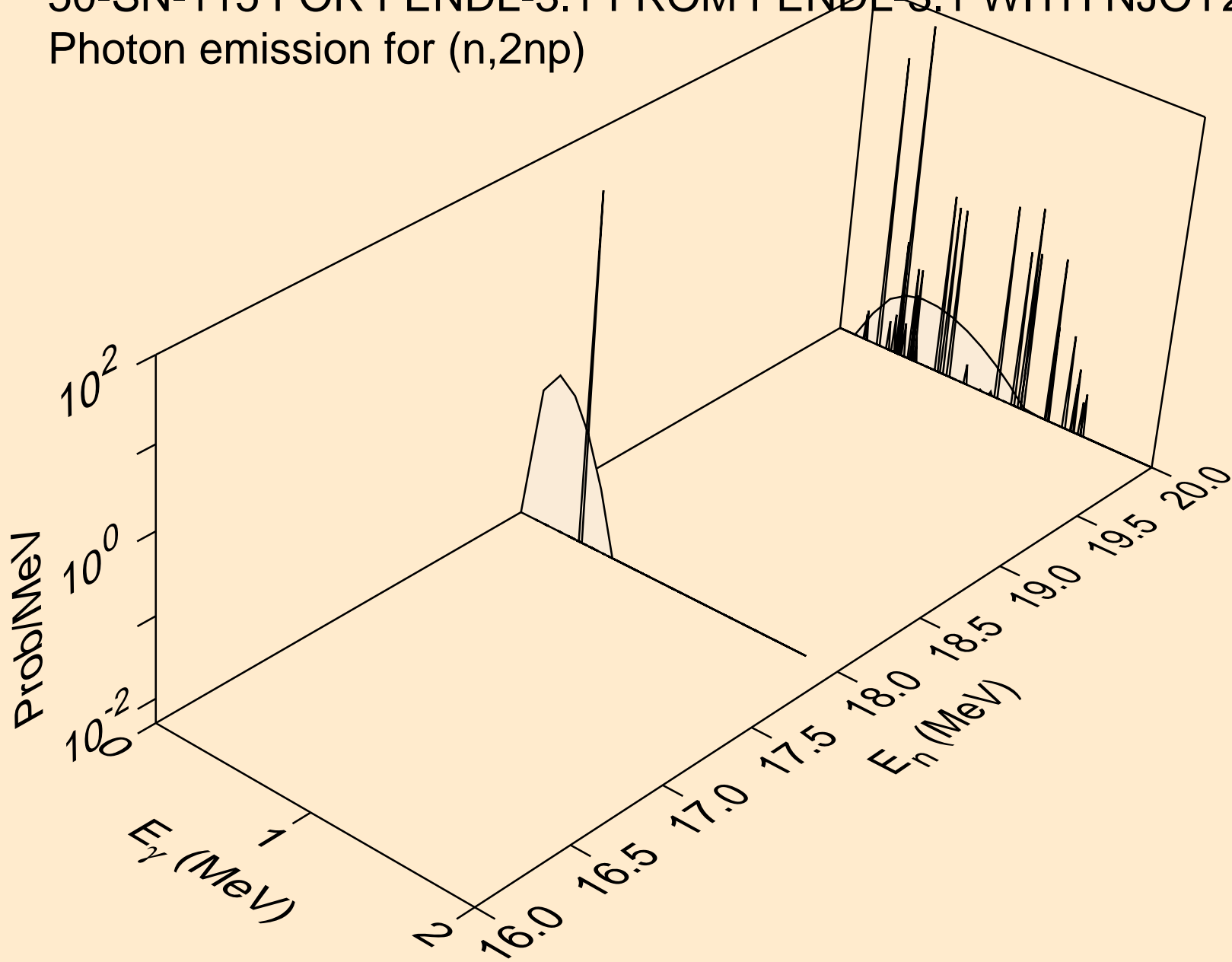



50-SN-115 FOR FENDL-3.1 FROM FENDL-3.1 WITH NJOY2012.50  
Photon emission for (n,n\*1)

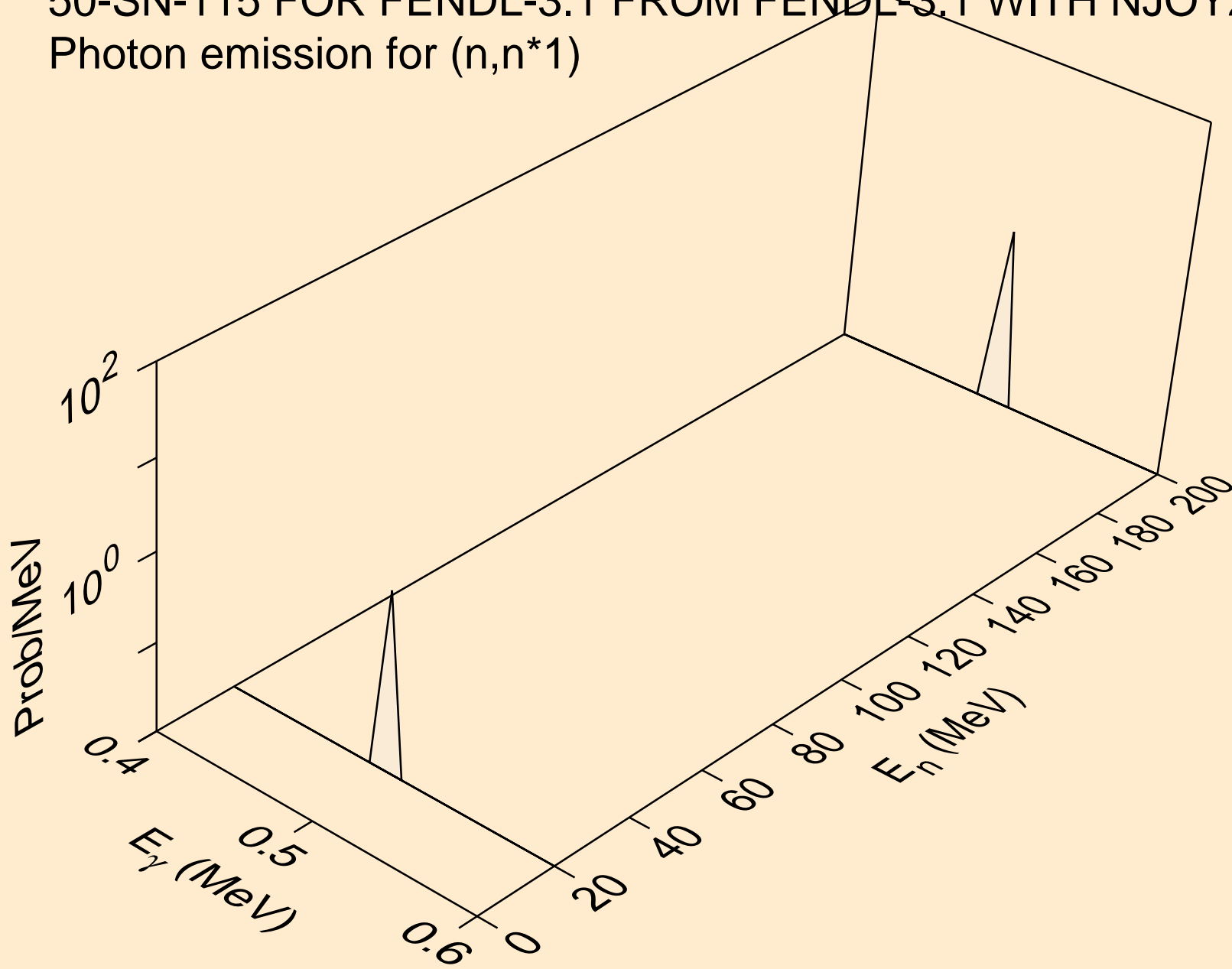

50-SN-115 FOR FENDL-3.1 FROM FENDL-3.1 WITH NJOY2012.50  
Photon emission for (n,n\*2)

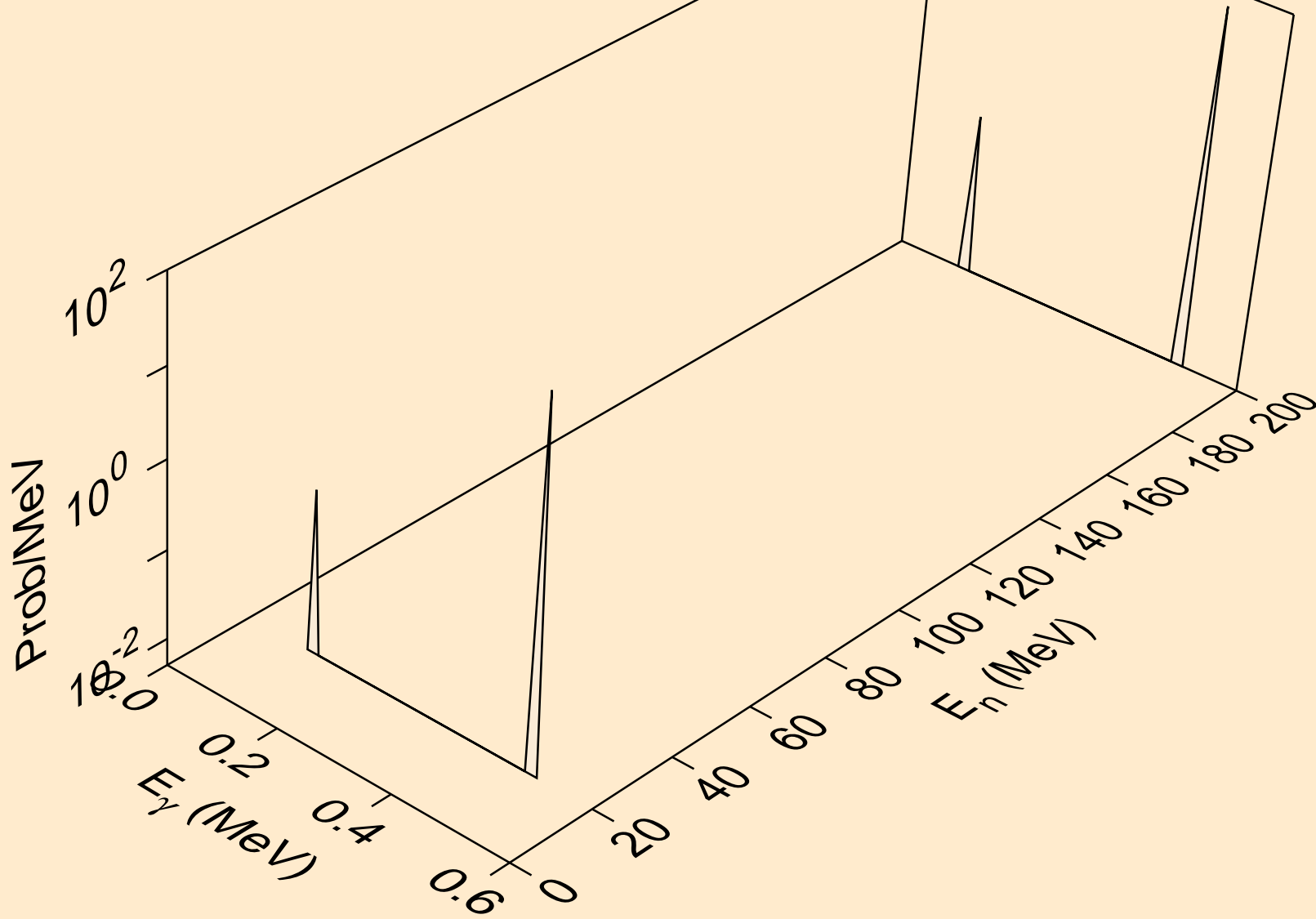

50-SN-115 FOR FENDL-3.1 FROM FENDL-3.1 WITH NJOY2012.50  
Photon emission for (n,n\*3)

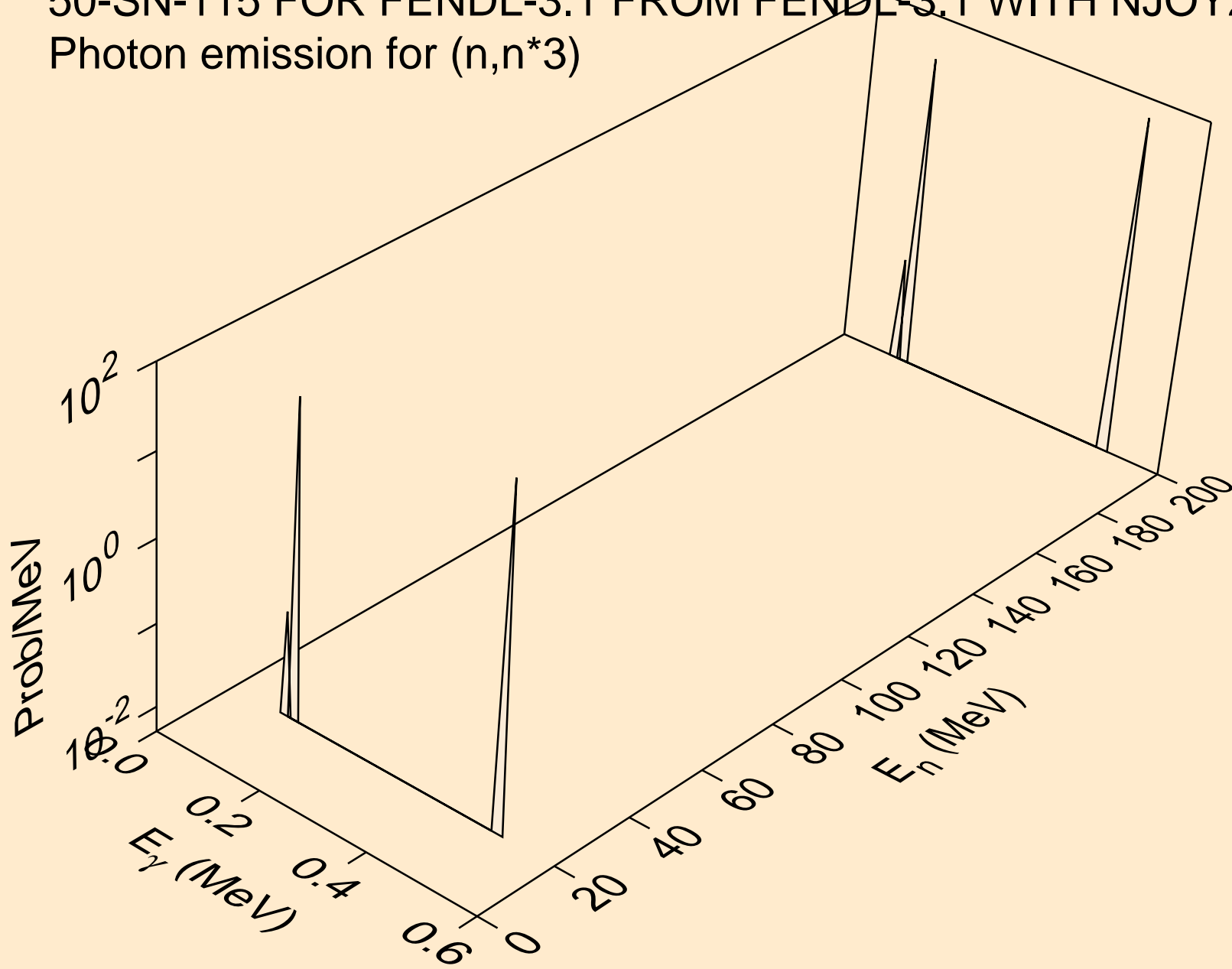

50-SN-115 FOR FENDL-3.1 FROM FENDL-3.1 WITH NJOY2012.50  
Photon emission for (n,n\*4)

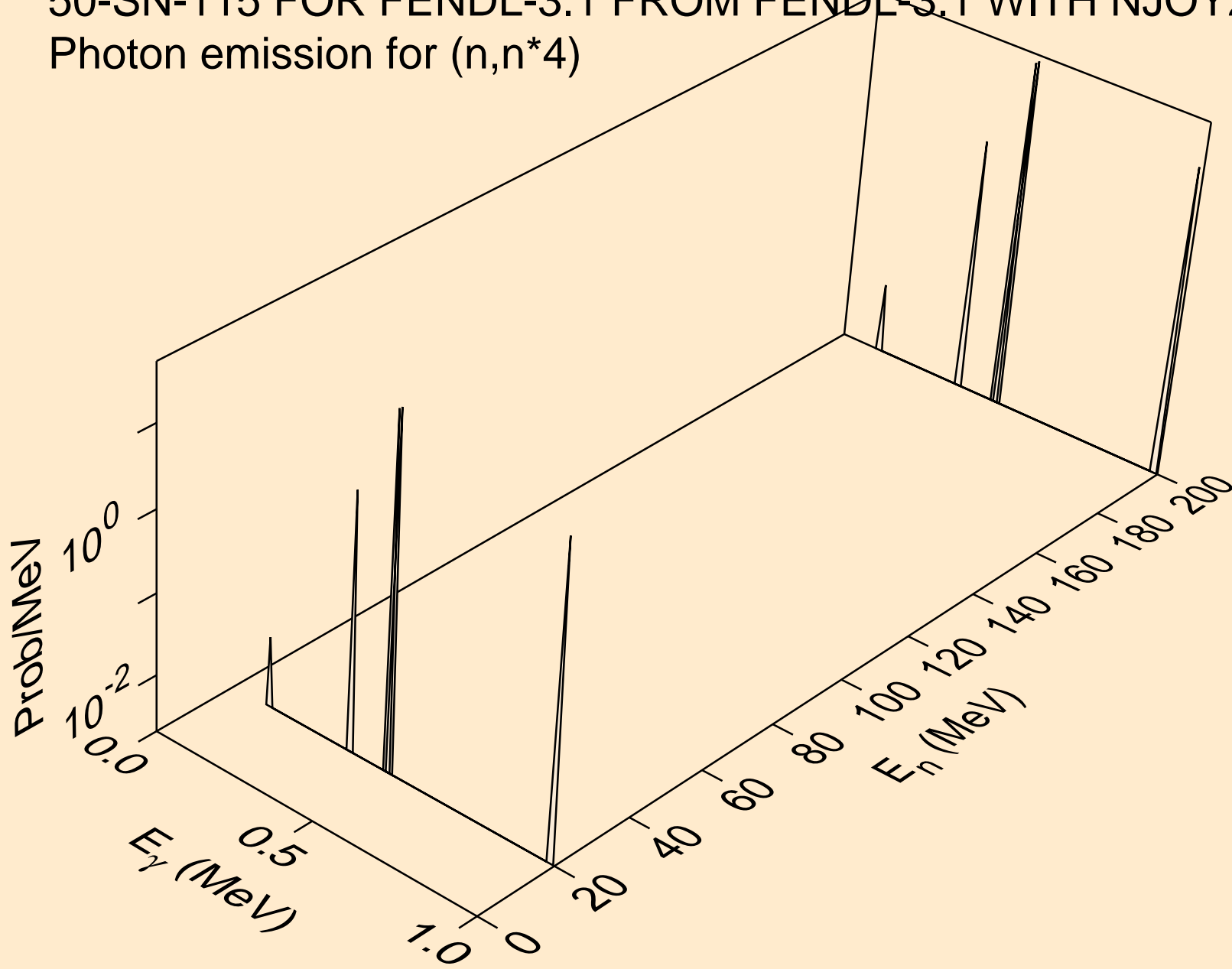

50-SN-115 FOR FENDL-3.1 FROM FENDL-3.1 WITH NJOY2012.50  
Photon emission for (n,n\*5)

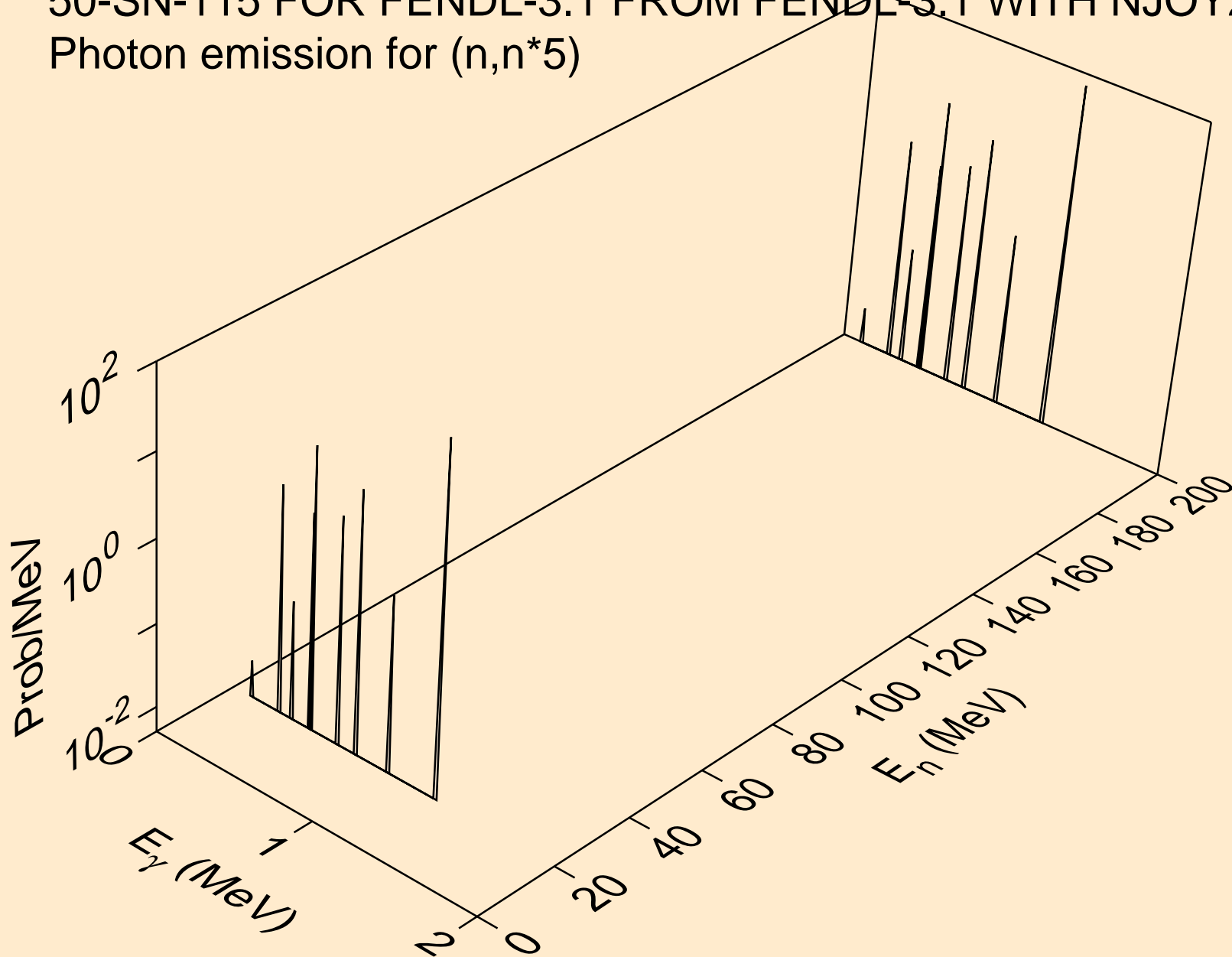

50-SN-115 FOR FENDL-3.1 FROM FENDL-3.1 WITH NJOY2012.50  
Photon emission for (n,n\*6)

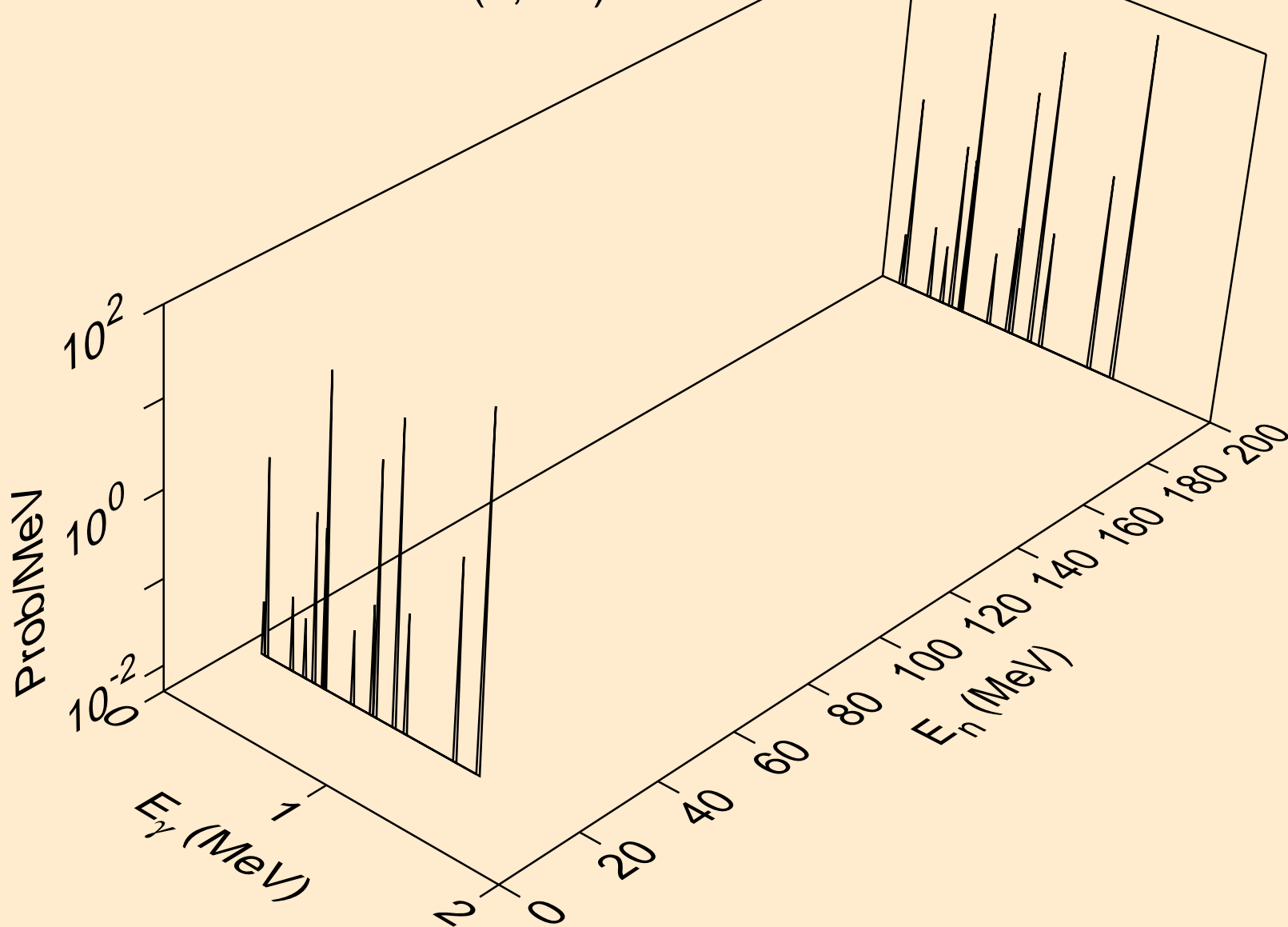

50-SN-115 FOR FENDL-3.1 FROM FENDL-3.1 WITH NJOY2012.50  
Photon emission for (n,n\*7)

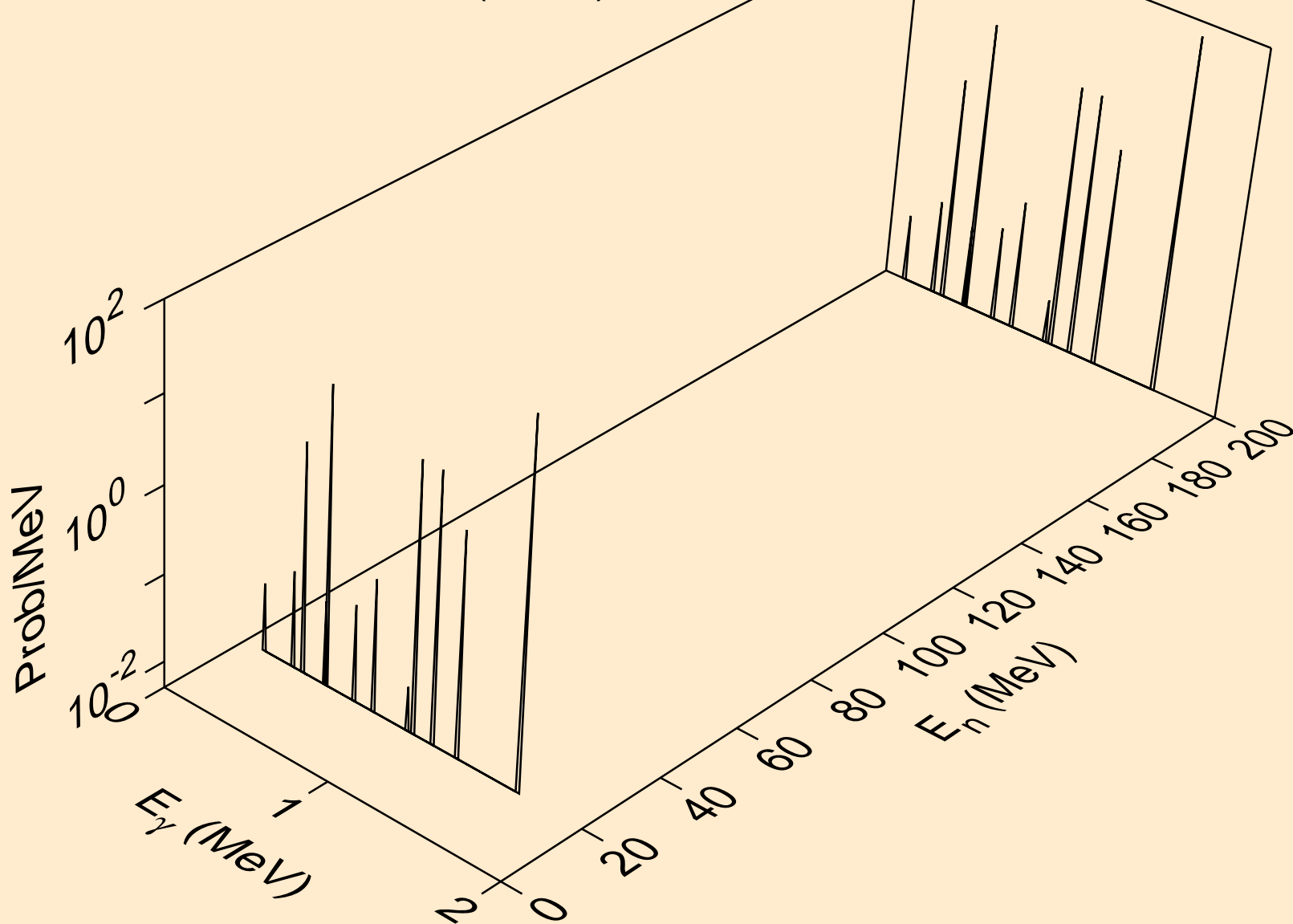

50-SN-115 FOR FENDL-3.1 FROM FENDL-3.1 WITH NJOY2012.50  
Photon emission for (n,n\*8)

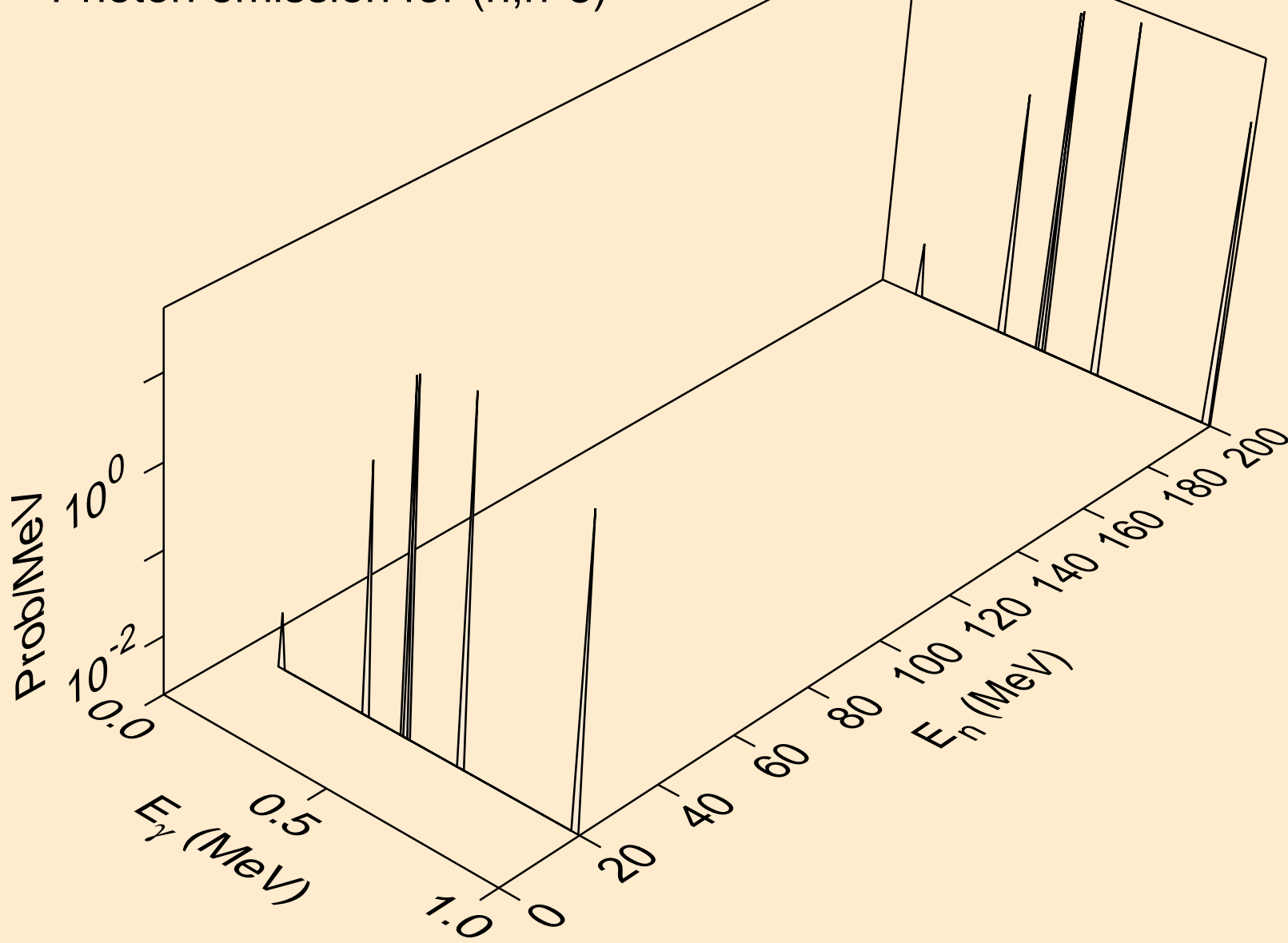



50-SN-115 FOR FENDL-3.1 FROM FENDL-3.1 WITH NJOY2012.50  
Photon emission for (n,n\*9)

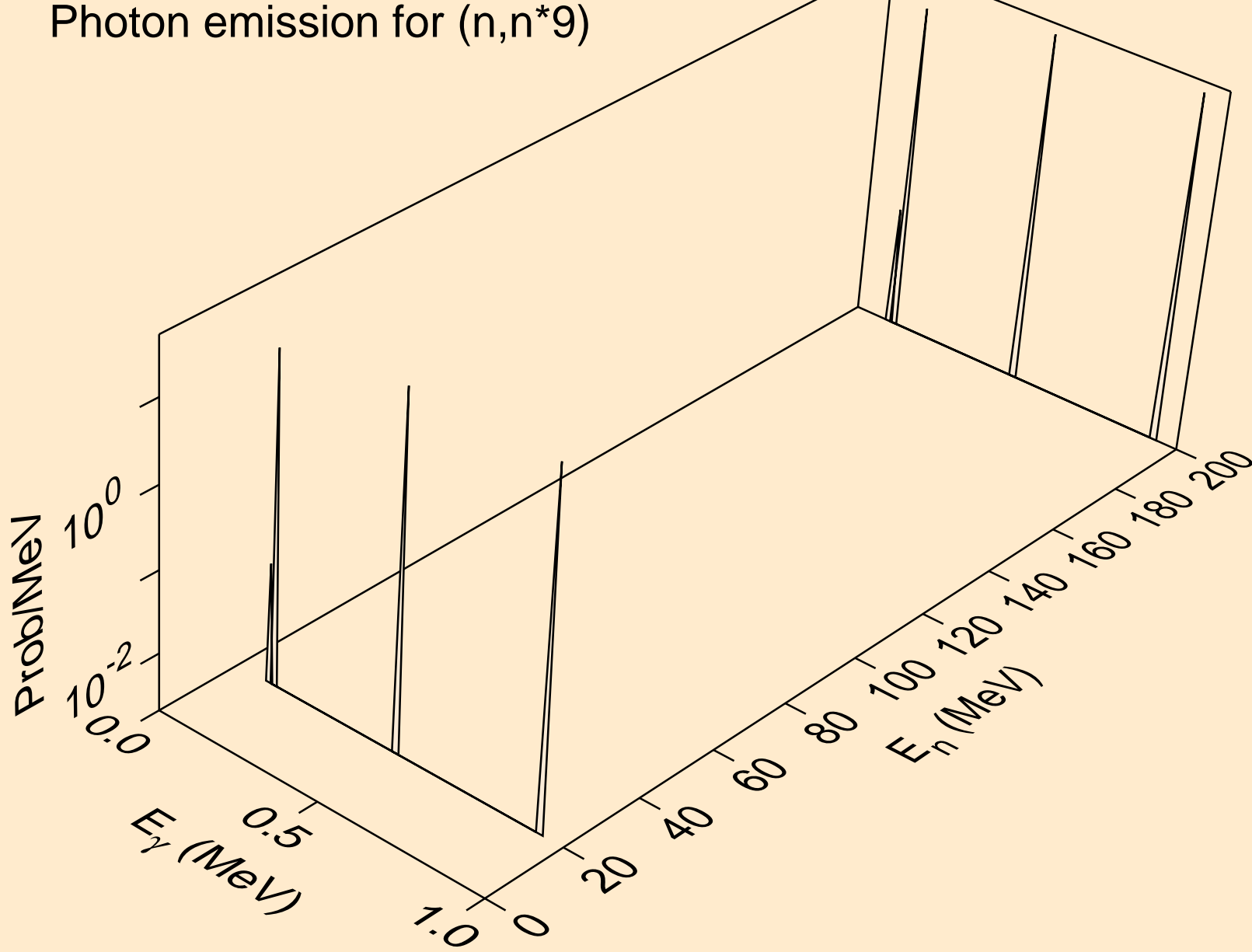

50-SN-115 FOR FENDL-3.1 FROM FENDL-3.1 WITH NJOY2012.50  
Photon emission for (n,n\*10)

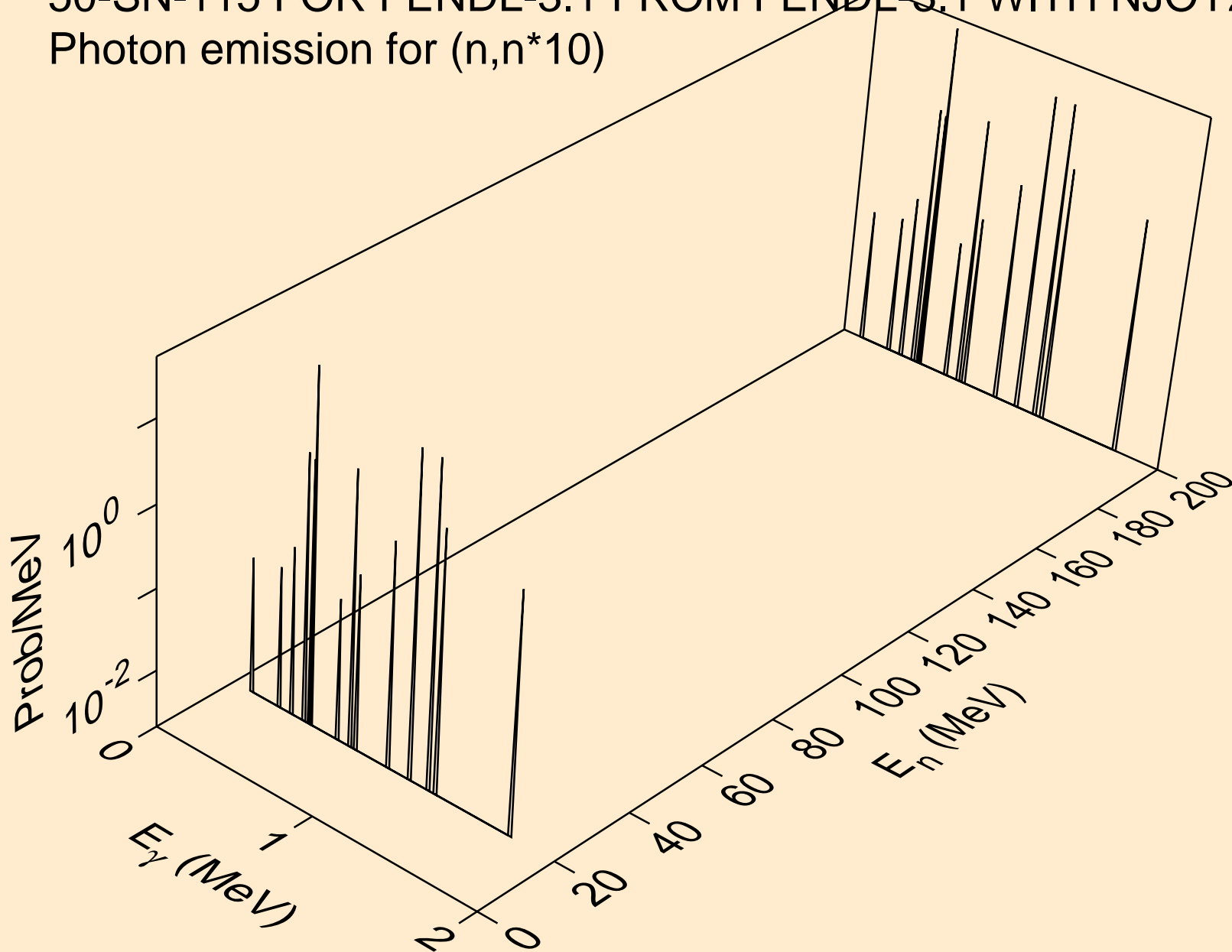

50-SN-115 FOR FENDL-3.1 FROM FENDL-3.1 WITH NJOY2012.50  
Photon emission for (n,n\*11)

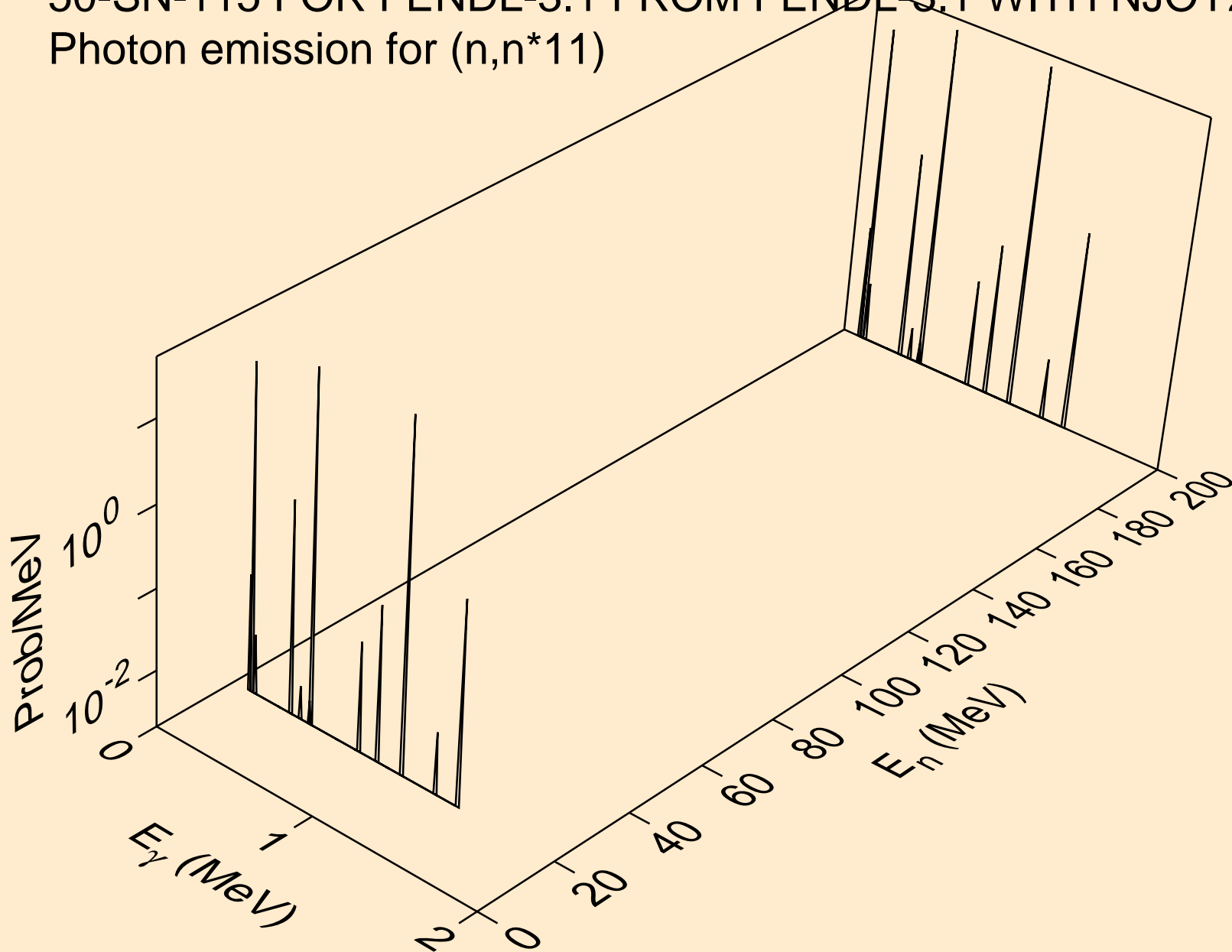

50-SN-115 FOR FENDL-3.1 FROM FENDL-3.1 WITH NJOY2012.50  
Photon emission for (n,n\*12)

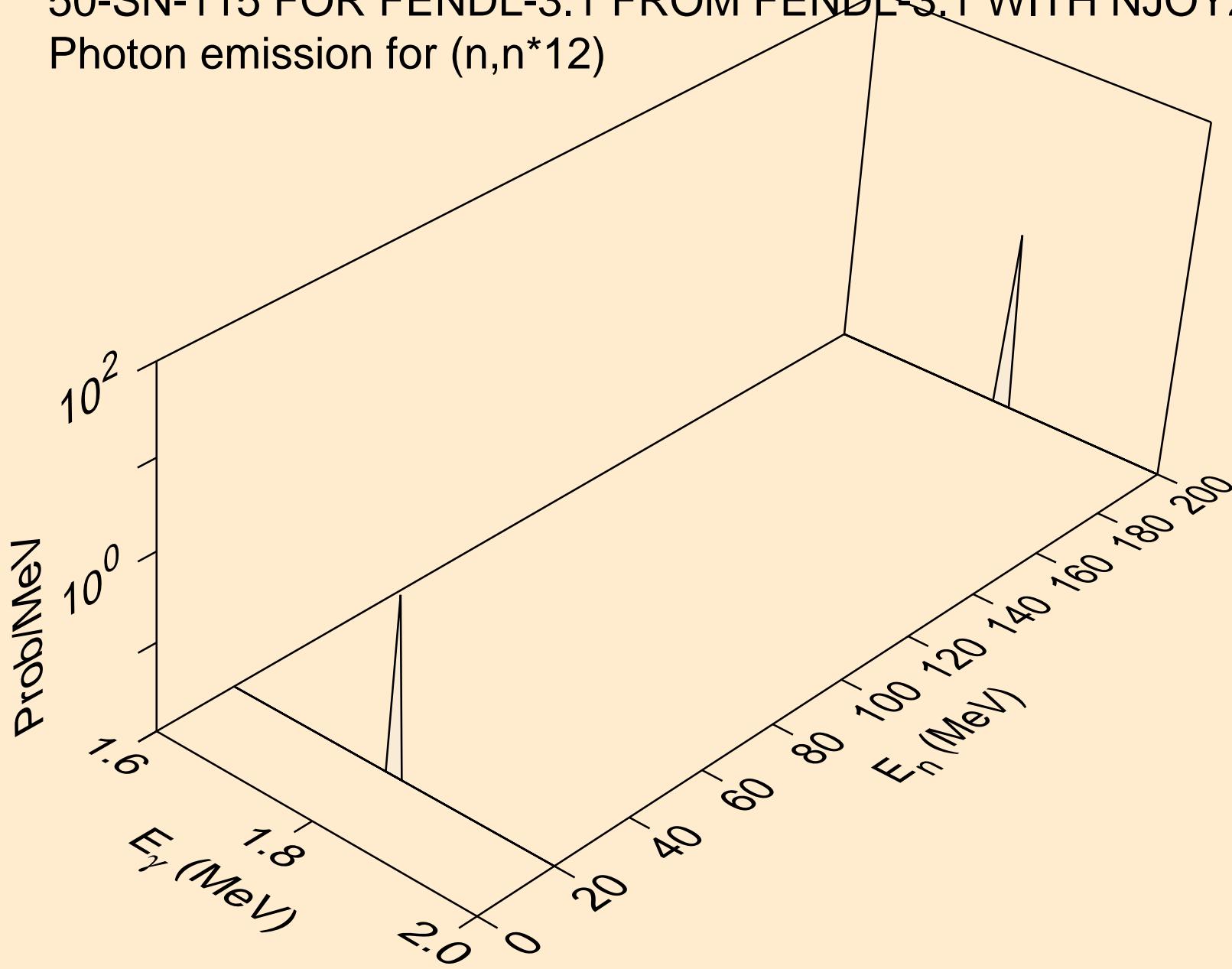

50-SN-115 FOR FENDL-3.1 FROM FENDL-3.1 WITH NJOY2012.50  
Photon emission for (n,n\*13)

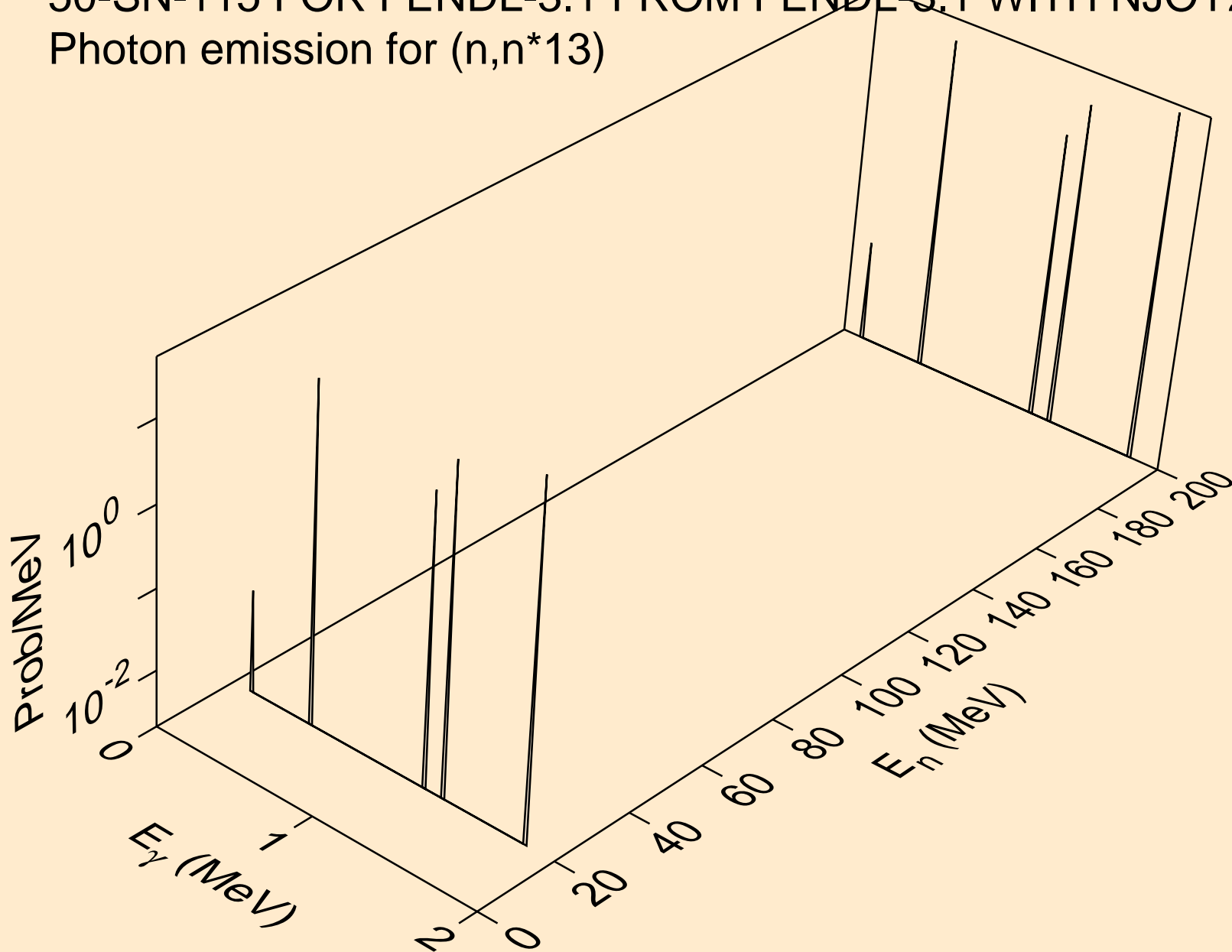

50-SN-115 FOR FENDL-3.1 FROM FENDL-3.1 WITH NJOY2012.50  
Photon emission for (n,n\*14)

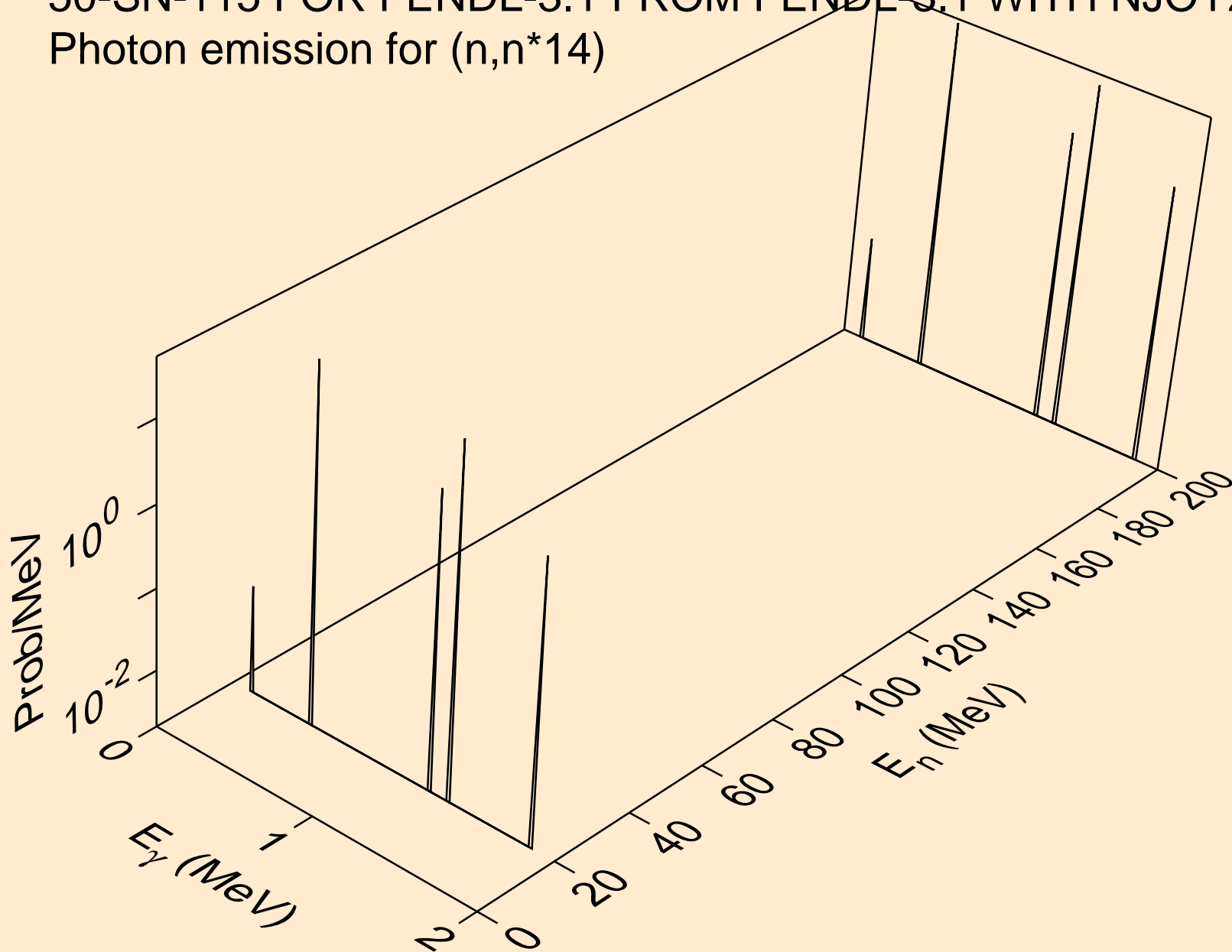

50-SN-115 FOR FENDL-3.1 FROM FENDL-3.1 WITH NJOY2012.50  
Photon emission for (n,n\*15)

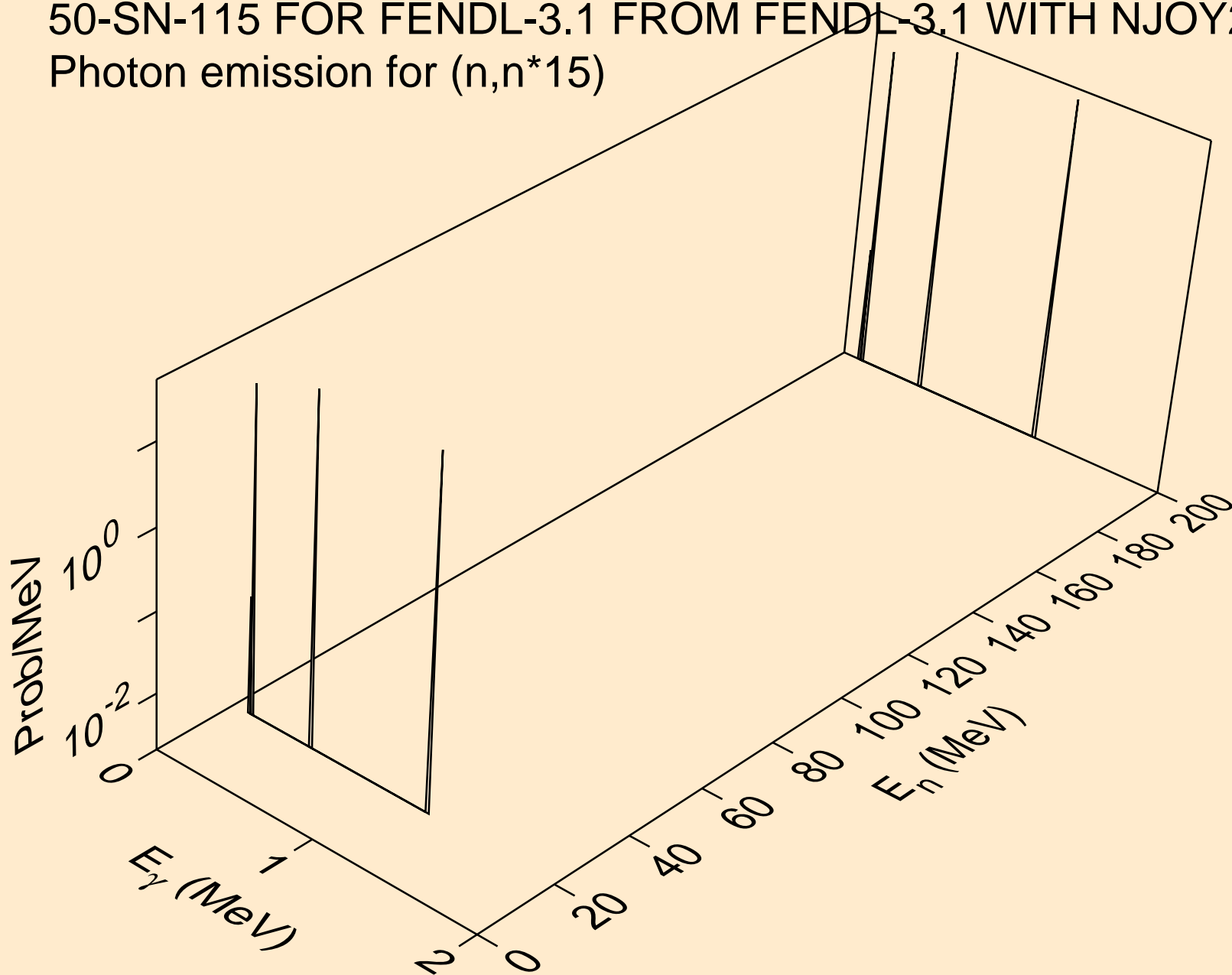

50-SN-115 FOR FENDL-3.1 FROM FENDL-3.1 WITH NJOY2012.50  
Photon emission for (n,n\*16)

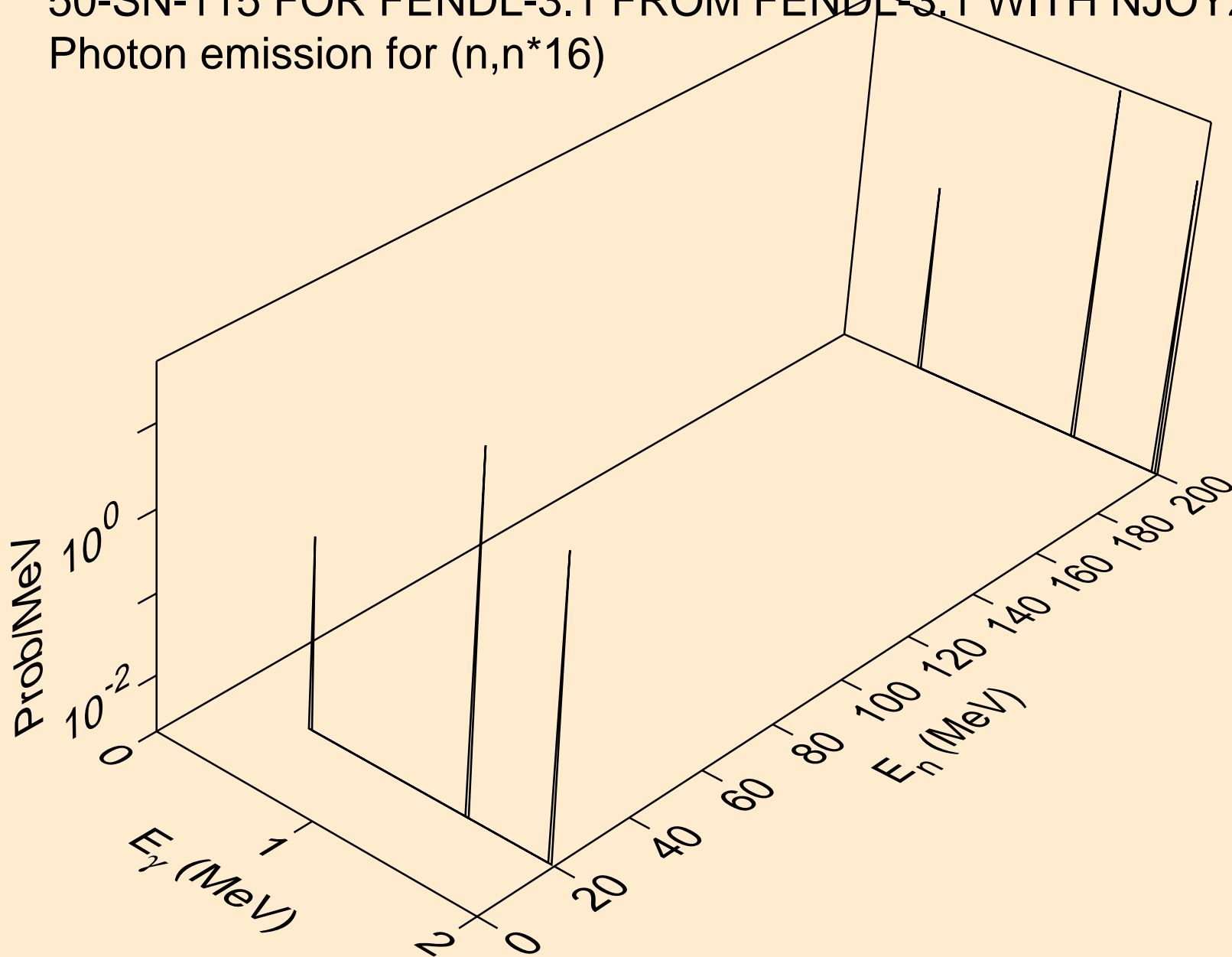



50-SN-115 FOR FENDL-3.1 FROM FENDL-3.1 WITH NJOY2012.50  
Photon emission for (n,n\*17)

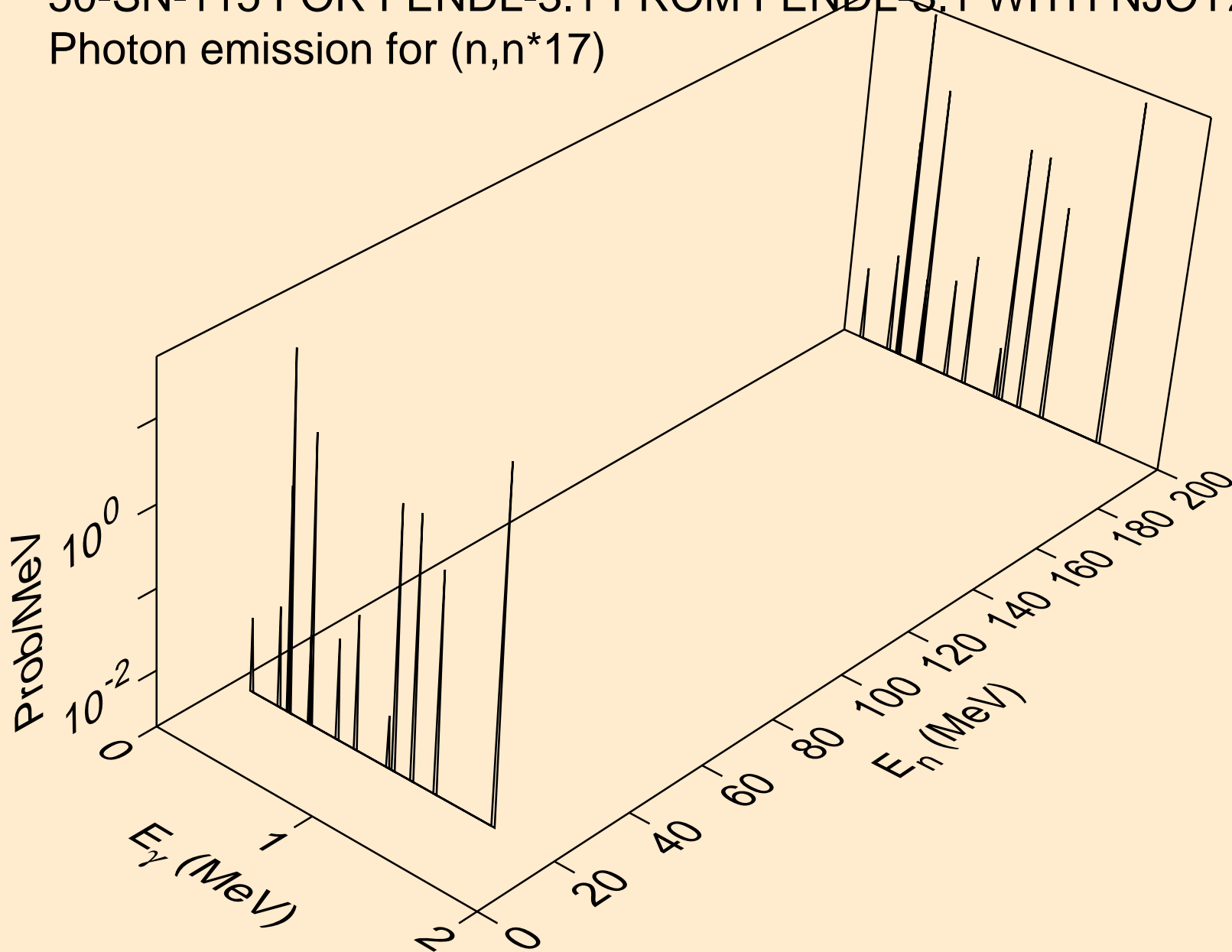

50-SN-115 FOR FENDL-3.1 FROM FENDL-3.1 WITH NJOY2012.50  
Photon emission for (n,n\*18)

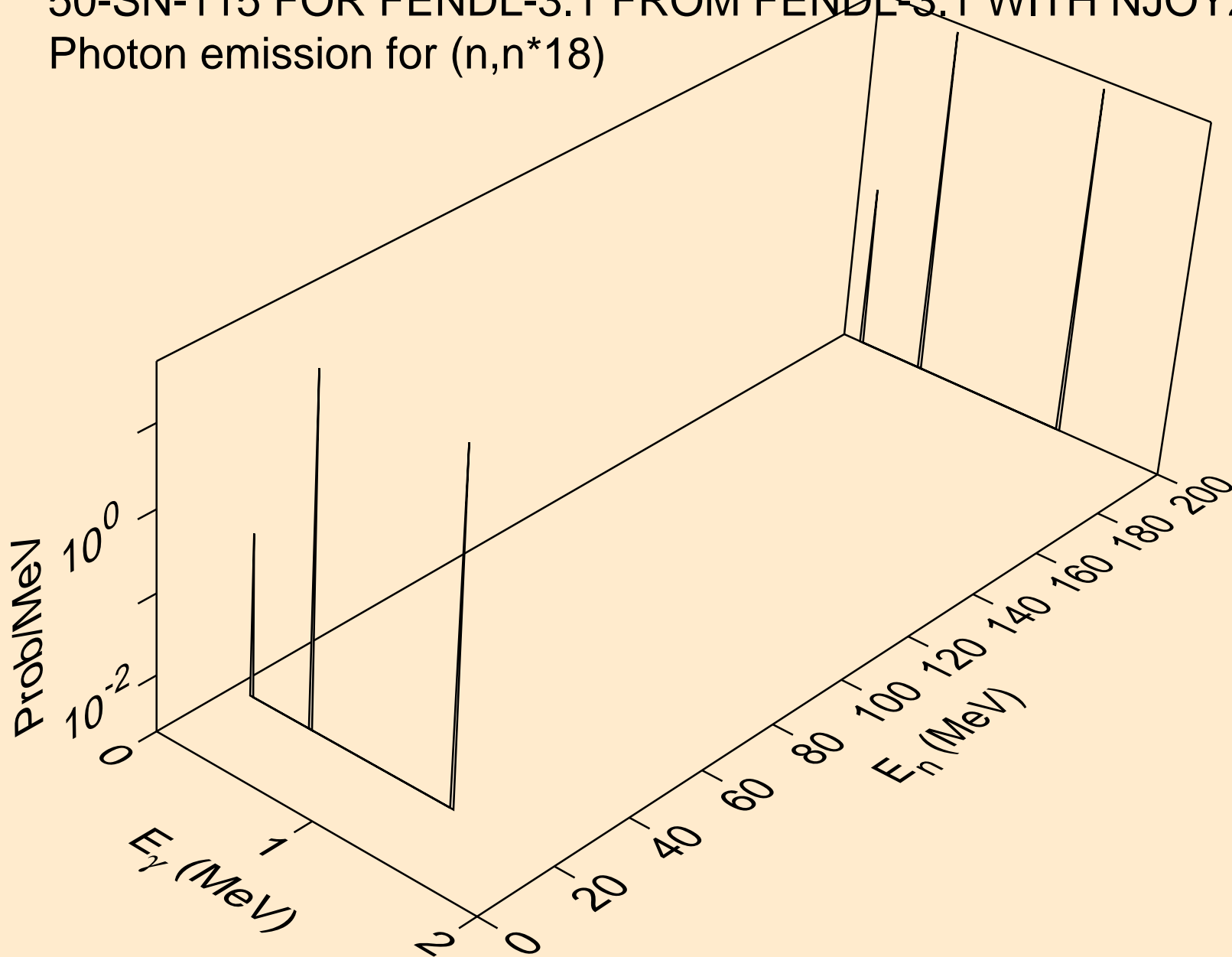

50-SN-115 FOR FENDL-3.1 FROM FENDL-3.1 WITH NJOY2012.50  
Photon emission for (n,n\*19)

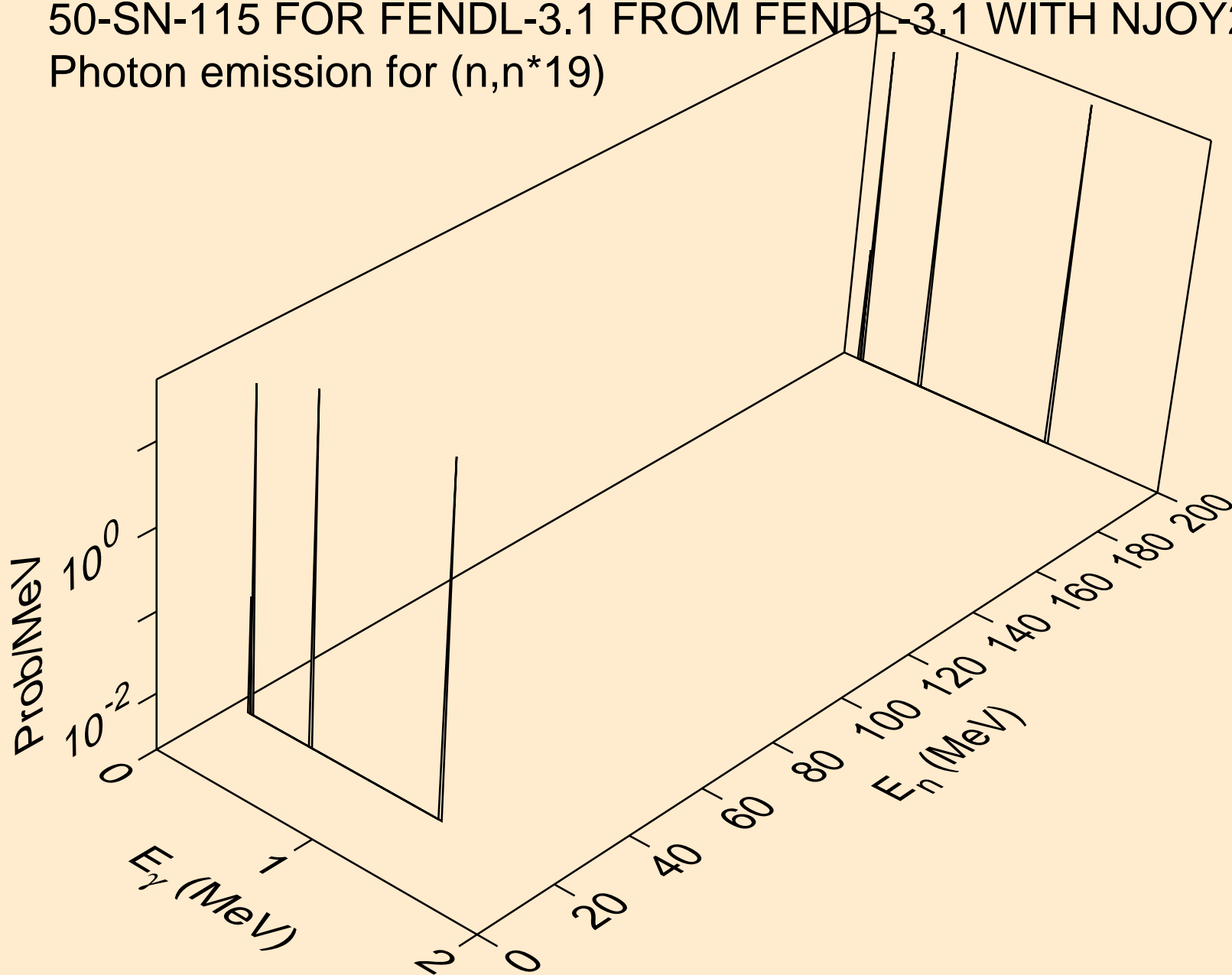

50-SN-115 FOR FENDL-3.1 FROM FENDL-3.1 WITH NJOY2012.50  
Photon emission for (n,n\*20)

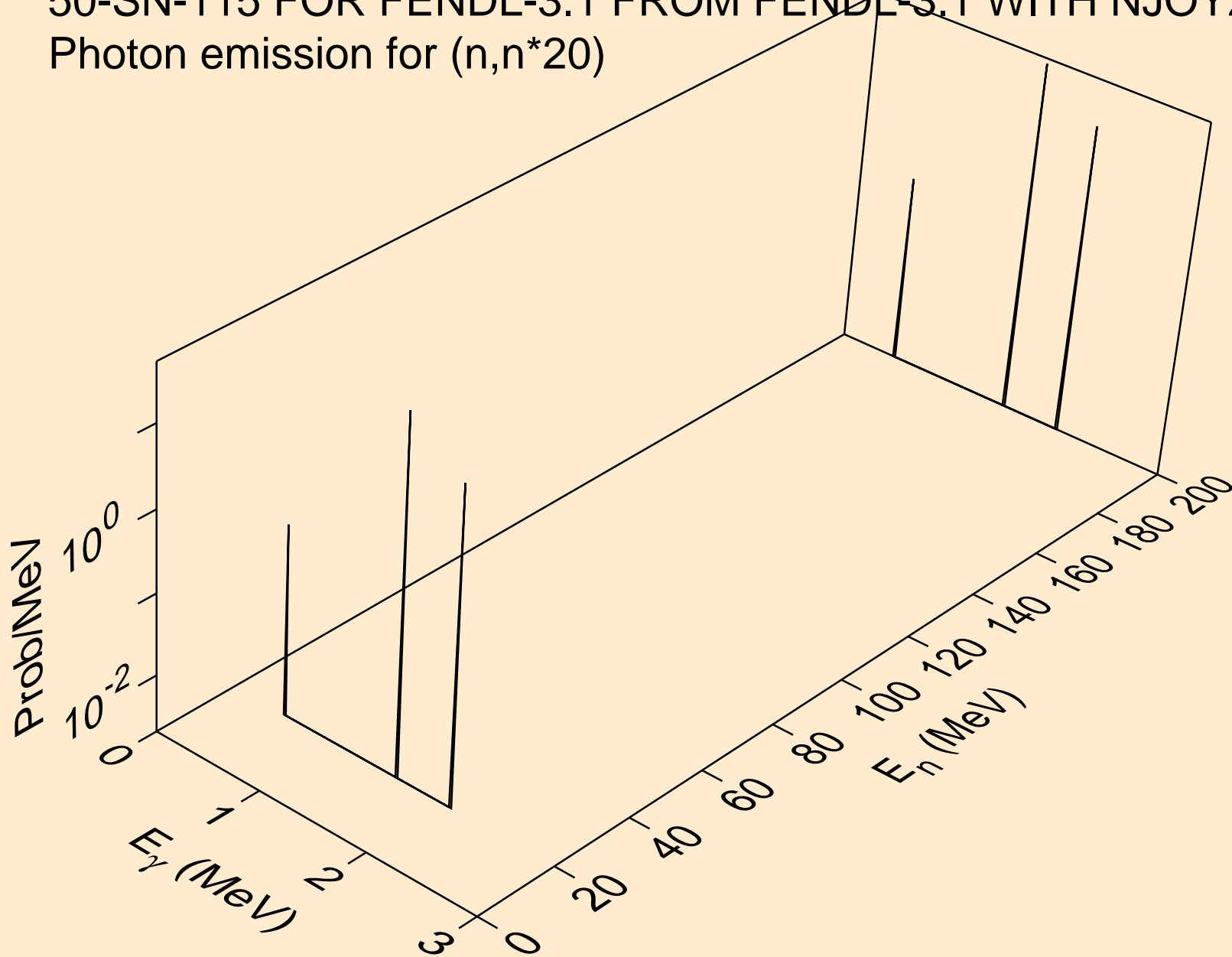

50-SN-115 FOR FENDL-3.1 FROM FENDL-3.1 WITH NJOY2012.50  
Photon emission for (n,n\*21)

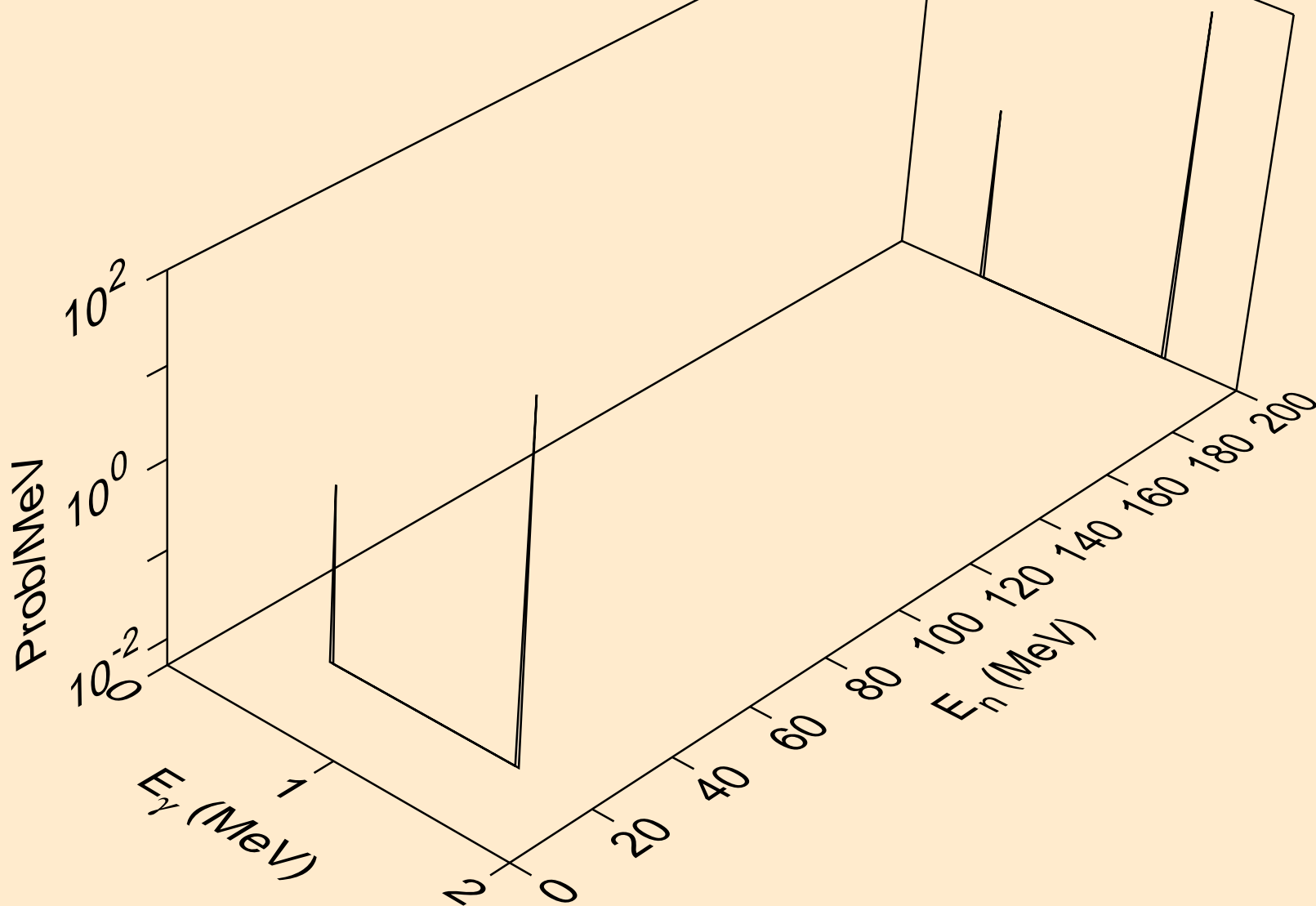

50-SN-115 FOR FENDL-3.1 FROM FENDL-3.1 WITH NJOY2012.50  
Photon emission for (n,n\*22)

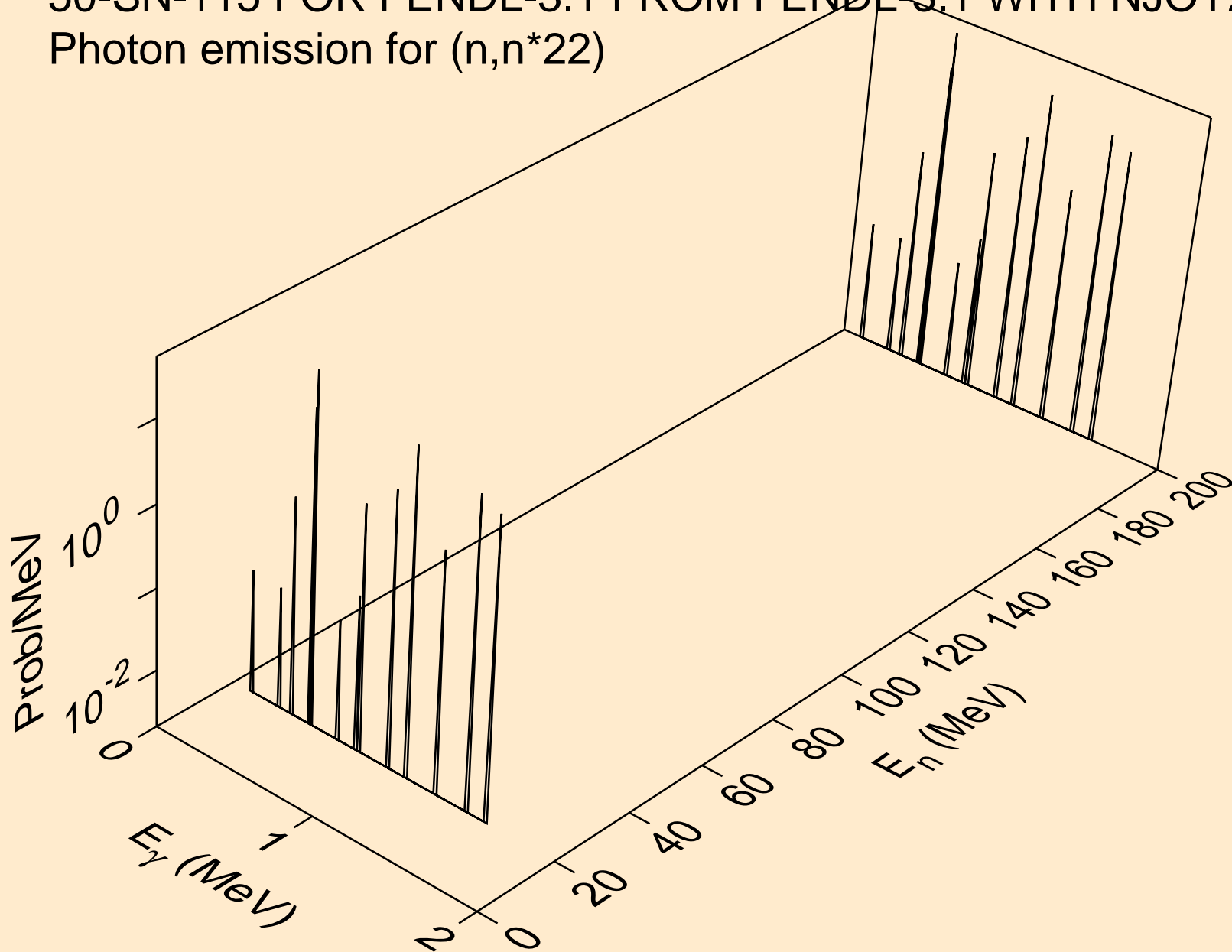

50-SN-115 FOR FENDL-3.1 FROM FENDL-3.1 WITH NJOY2012.50  
Photon emission for (n,n\*23)

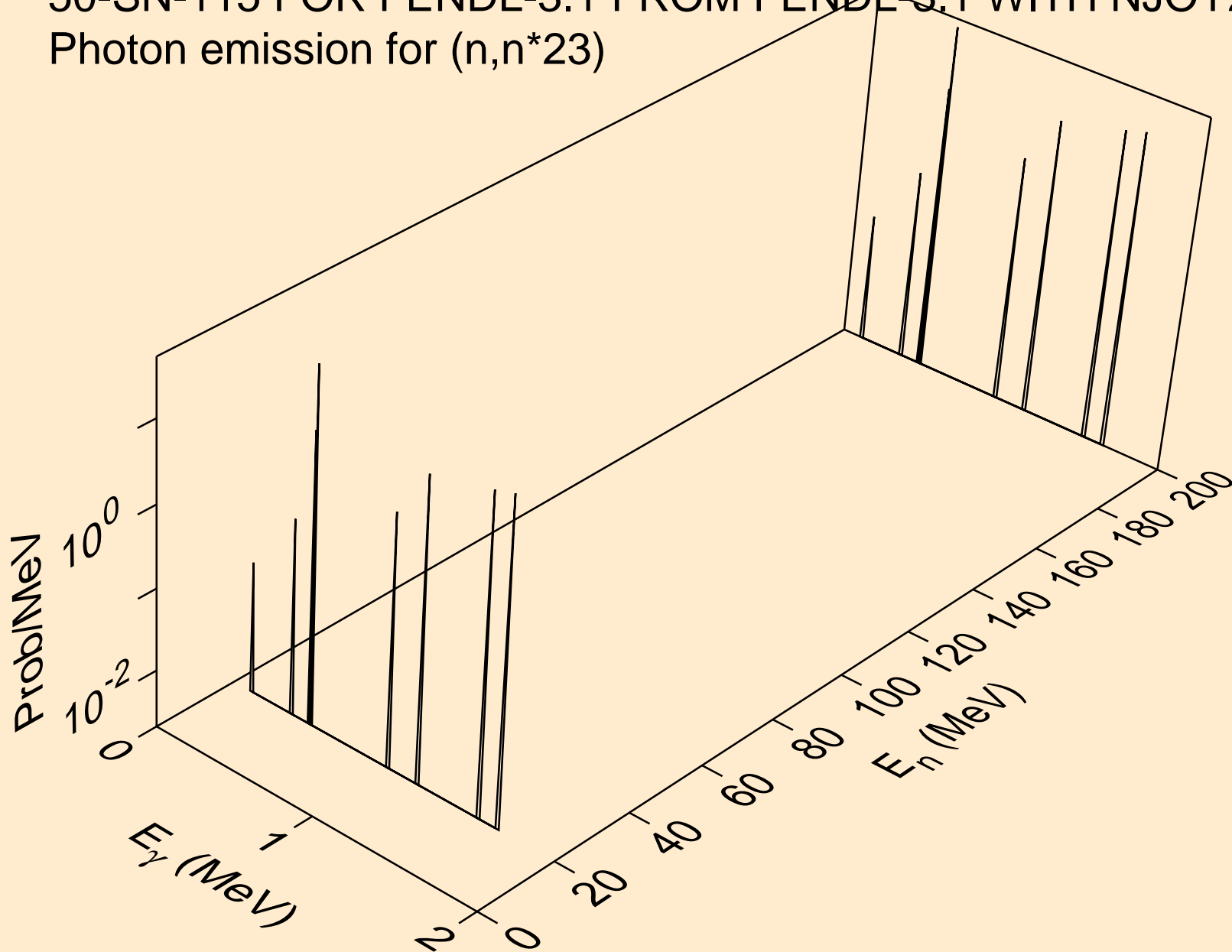

50-SN-115 FOR FENDL-3.1 FROM FENDL-3.1 WITH NJOY2012.50  
Photon emission for (n,n\*24)

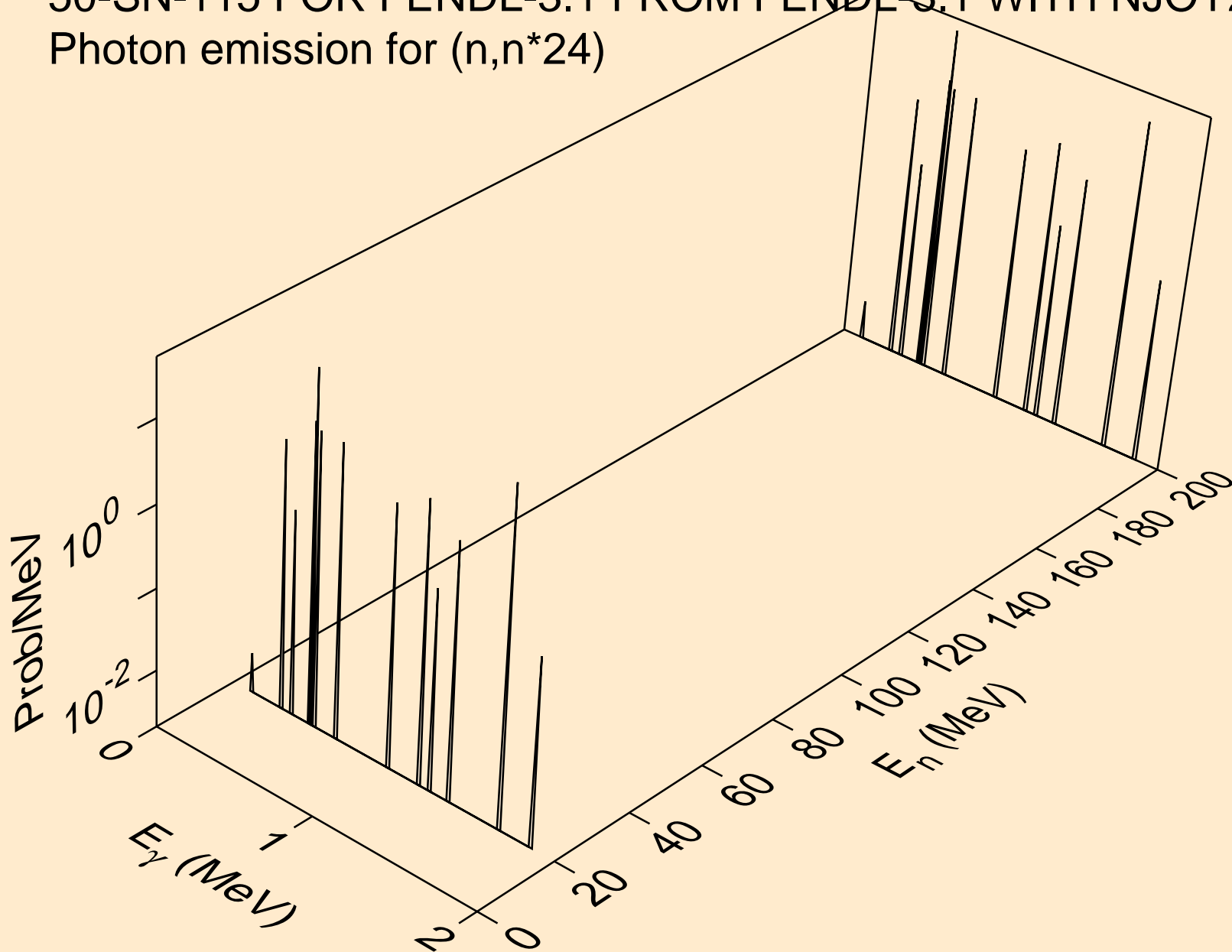



50-SN-115 FOR FENDL-3.1 FROM FENDL-3.1 WITH NJOY2012.50  
Photon emission for (n,n\*25)

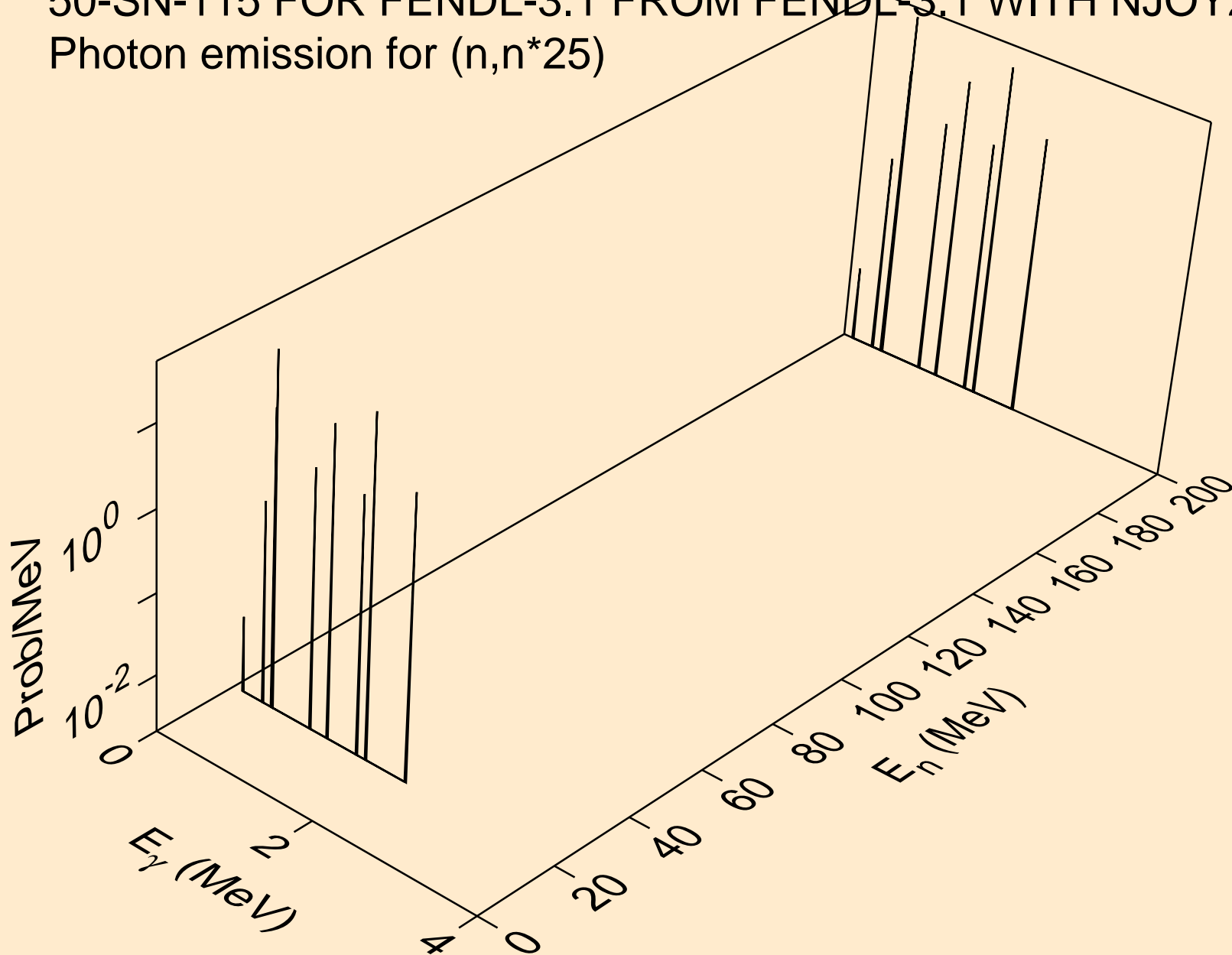

50-SN-115 FOR FENDL-3.1 FROM FENDL-3.1 WITH NJOY2012.50  
Photon emission for (n,n\*26)

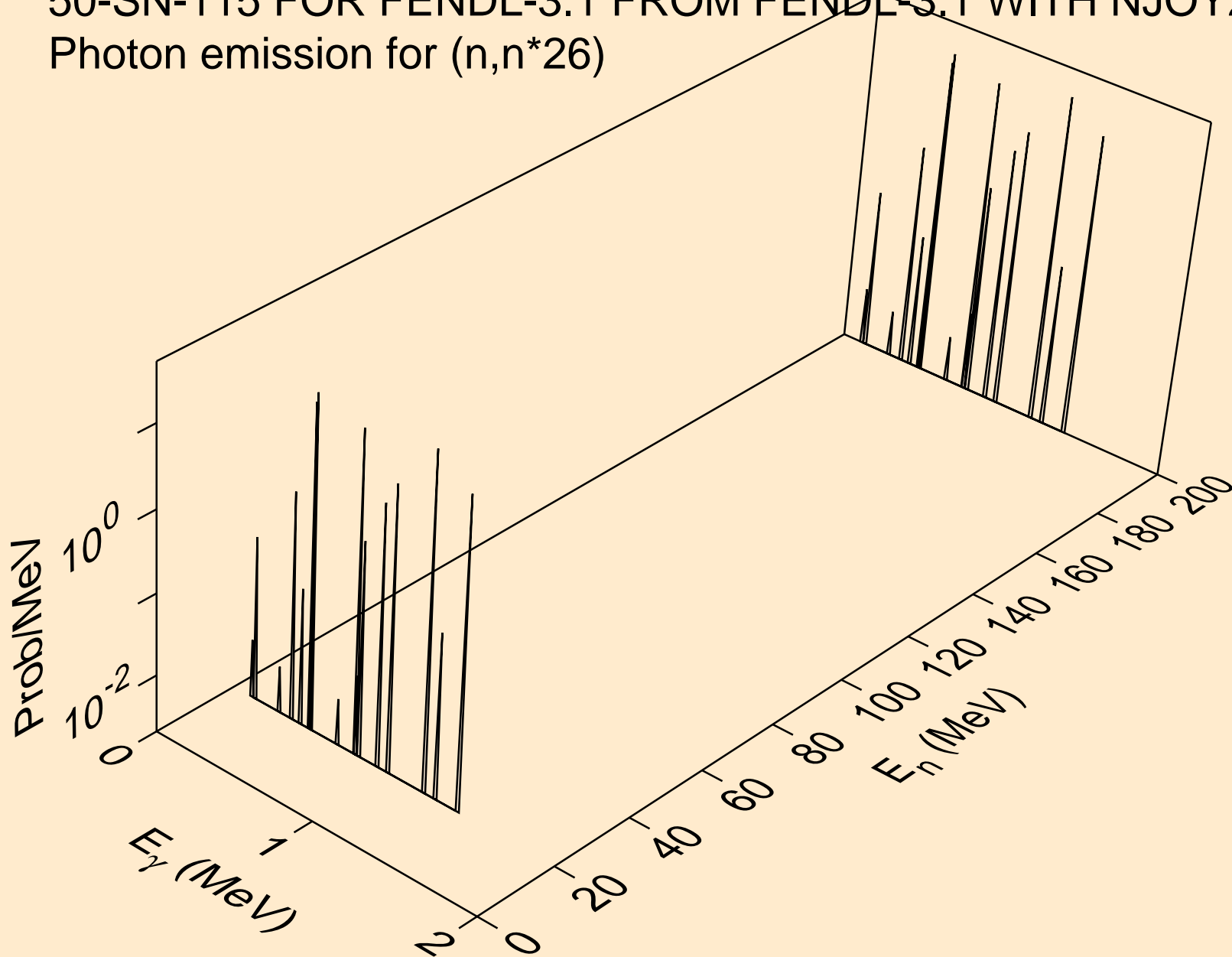

50-SN-115 FOR FENDL-3.1 FROM FENDL-3.1 WITH NJOY2012.50  
Photon emission for (n,n\*27)

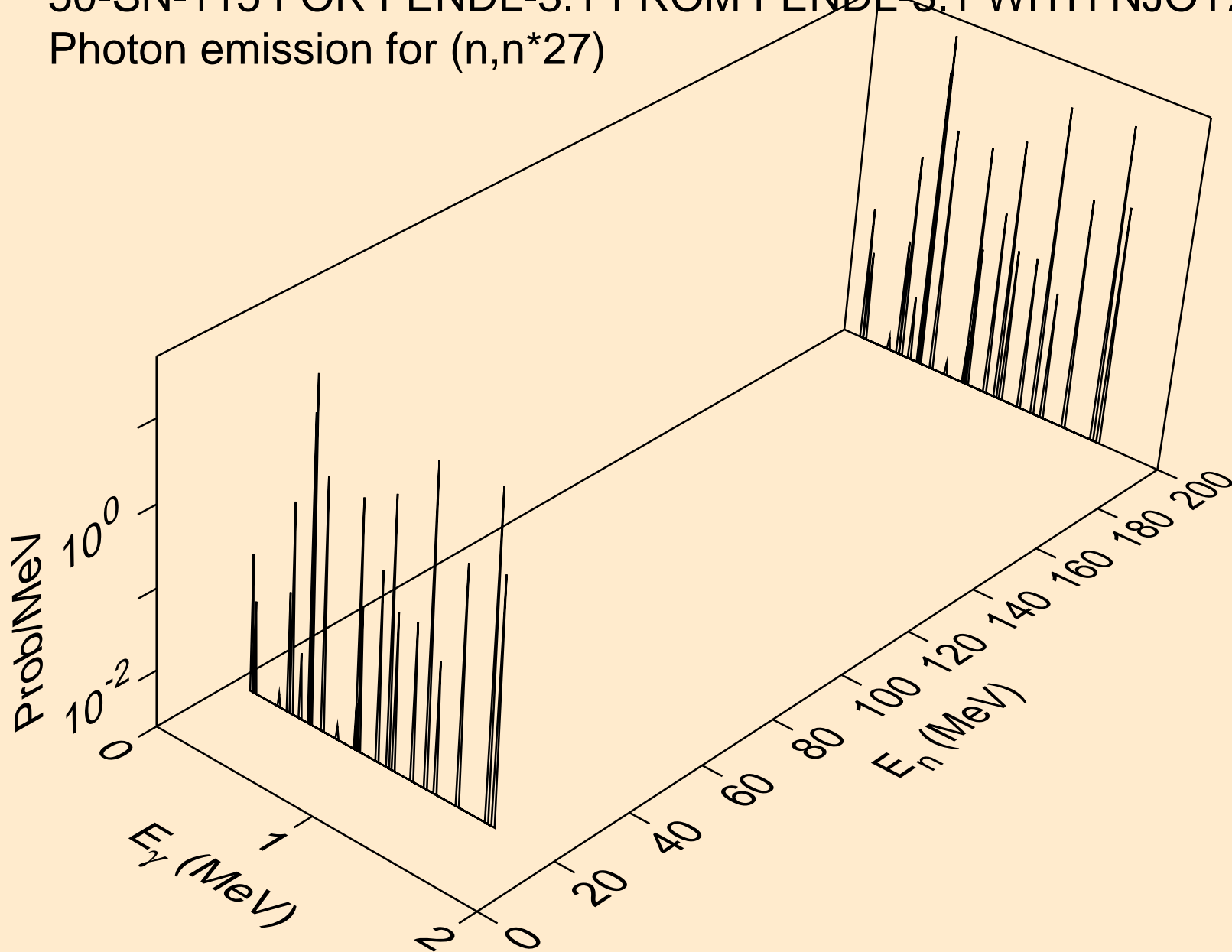

50-SN-115 FOR FENDL-3.1 FROM FENDL-3.1 WITH NJOY2012.50  
Photon emission for (n,n\*28)

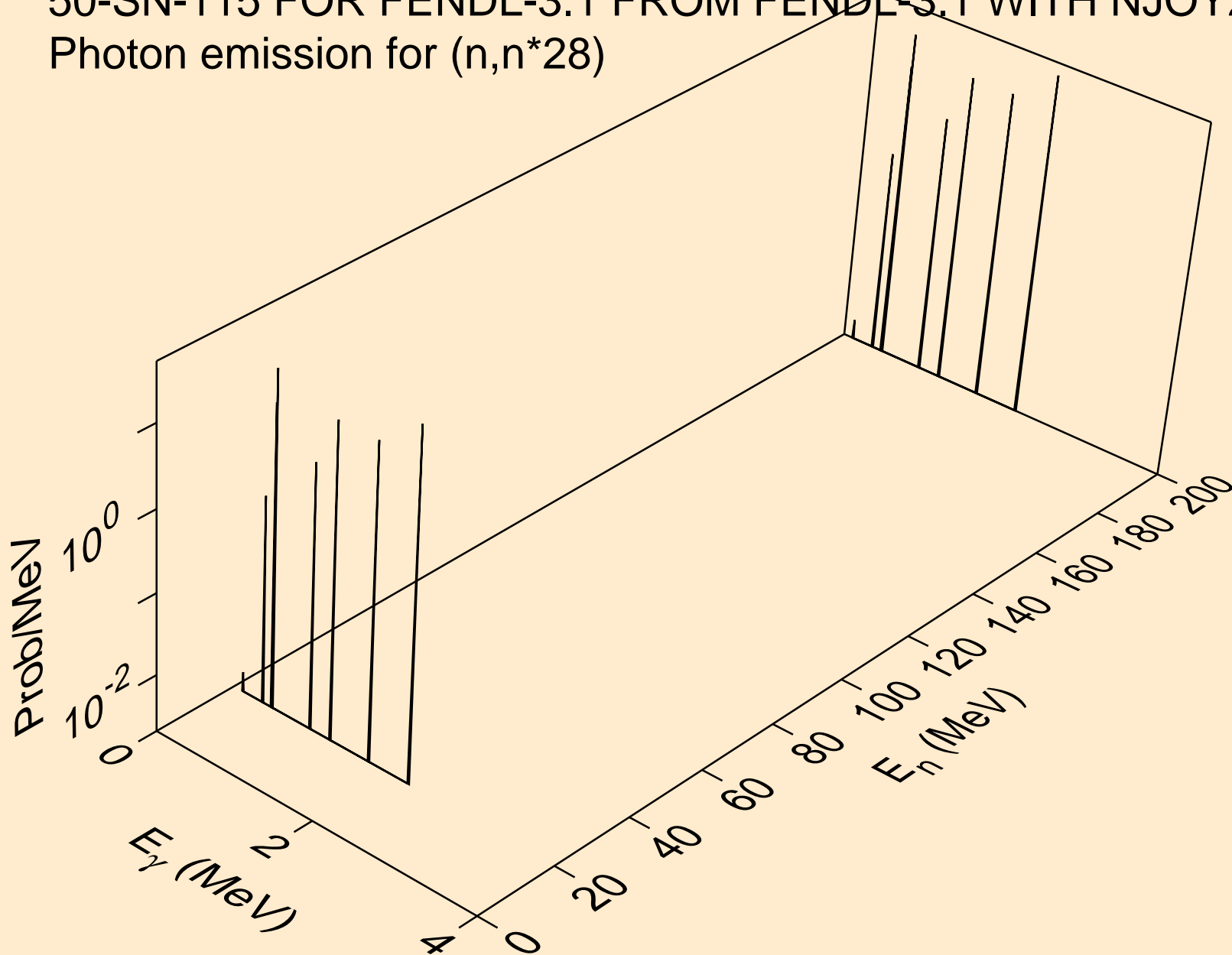

50-SN-115 FOR FENDL-3.1 FROM FENDL-3.1 WITH NJOY2012.50  
Photon emission for (n,n\*29)

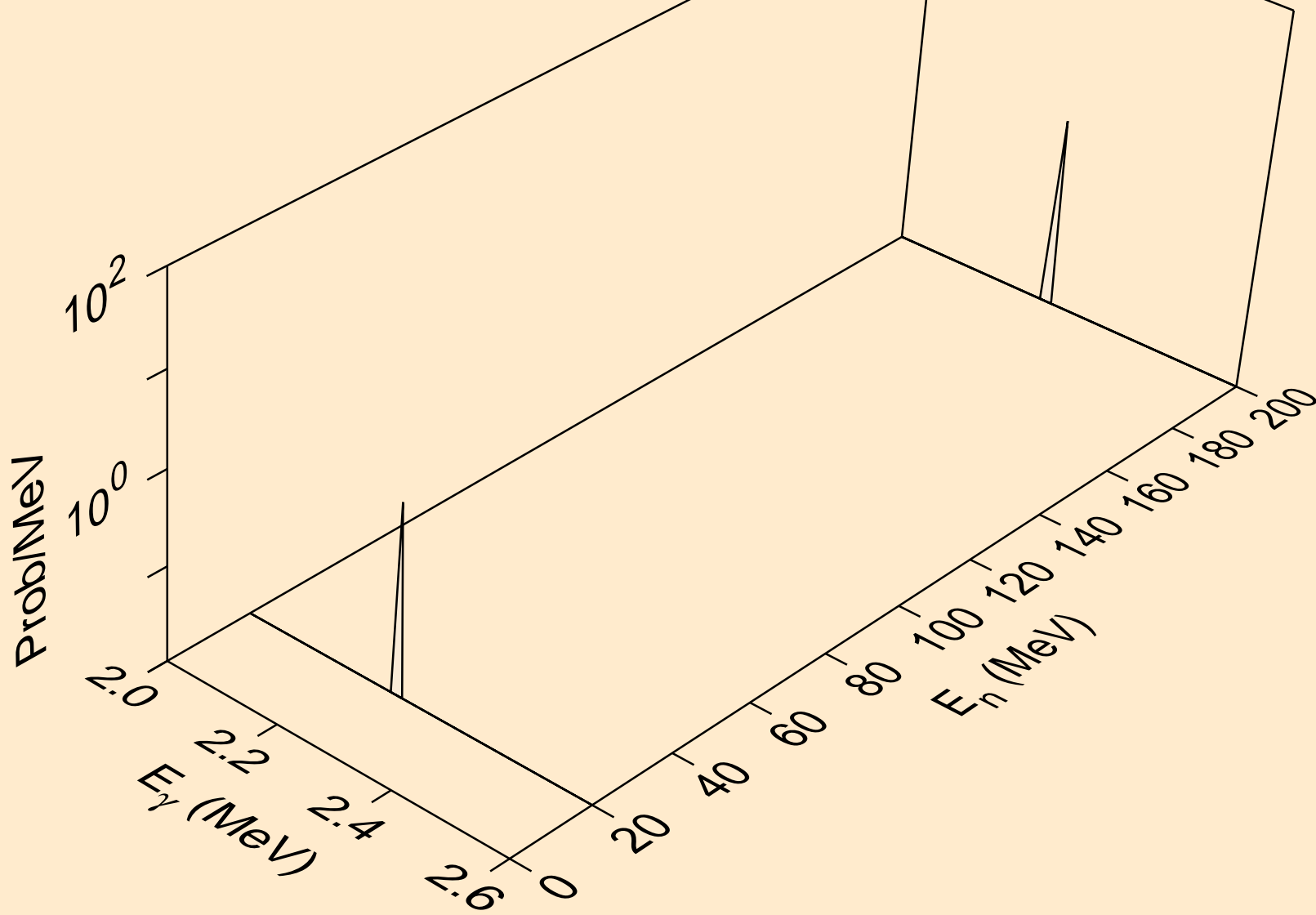

50-SN-115 FOR FENDL-3.1 FROM FENDL-3.1 WITH NJOY2012.50  
Photon emission for (n,n\*30)

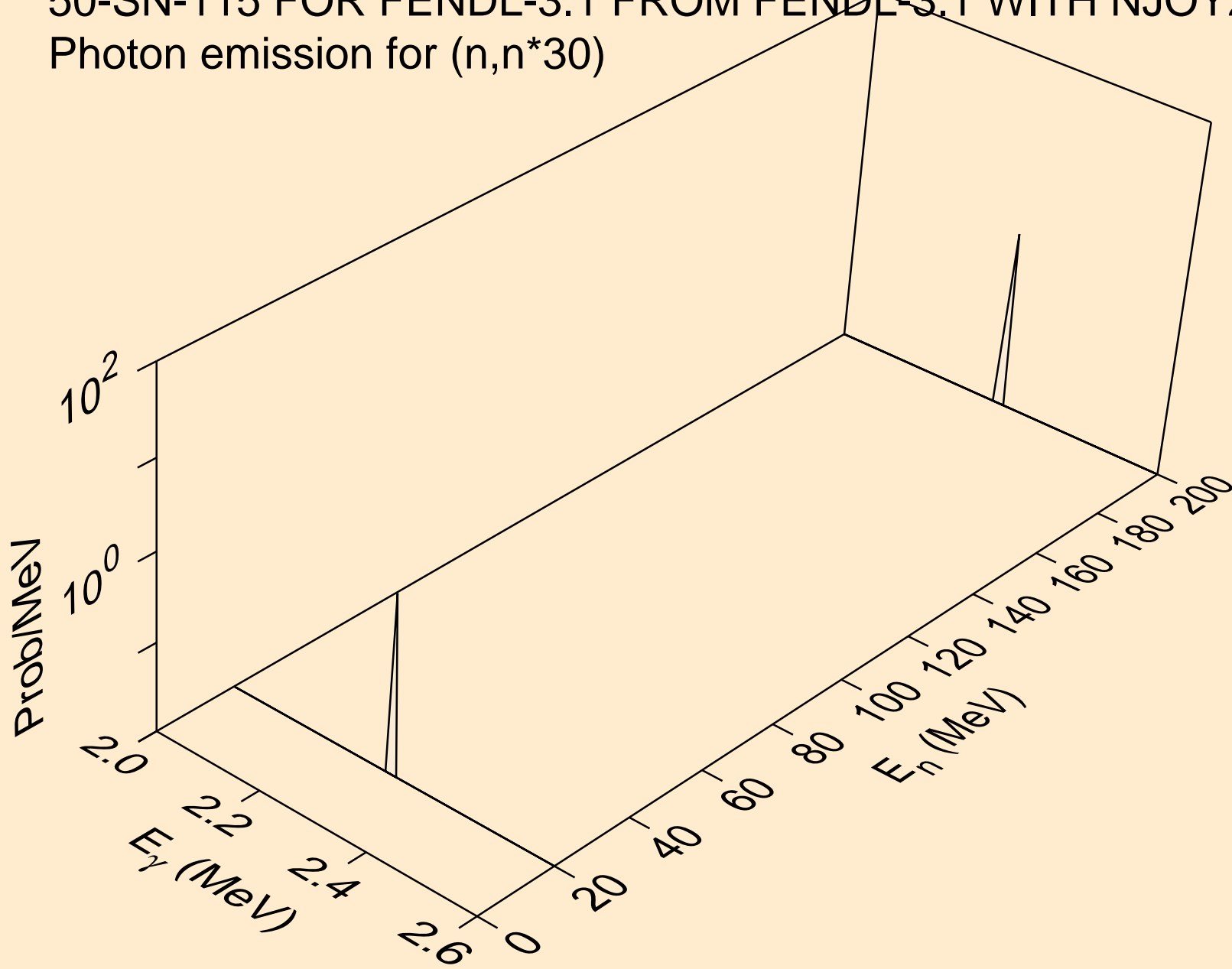

50-SN-115 FOR FENDL-3.1 FROM FENDL-3.1 WITH NJOY2012.50  
Photon emission for (n,n\*31)

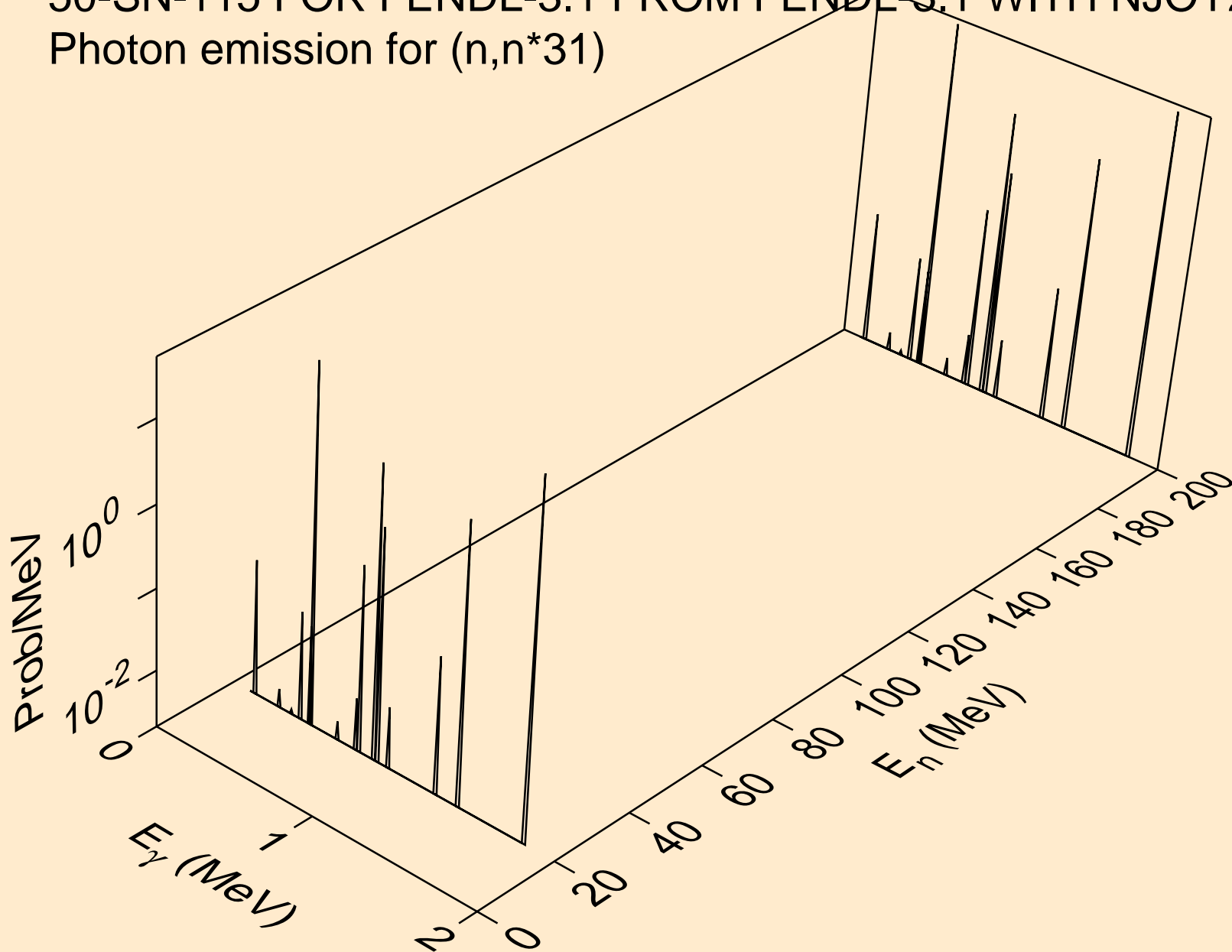

50-SN-115 FOR FENDL-3.1 FROM FENDL-3.1 WITH NJOY2012.50  
Photon emission for (n,n\*32)

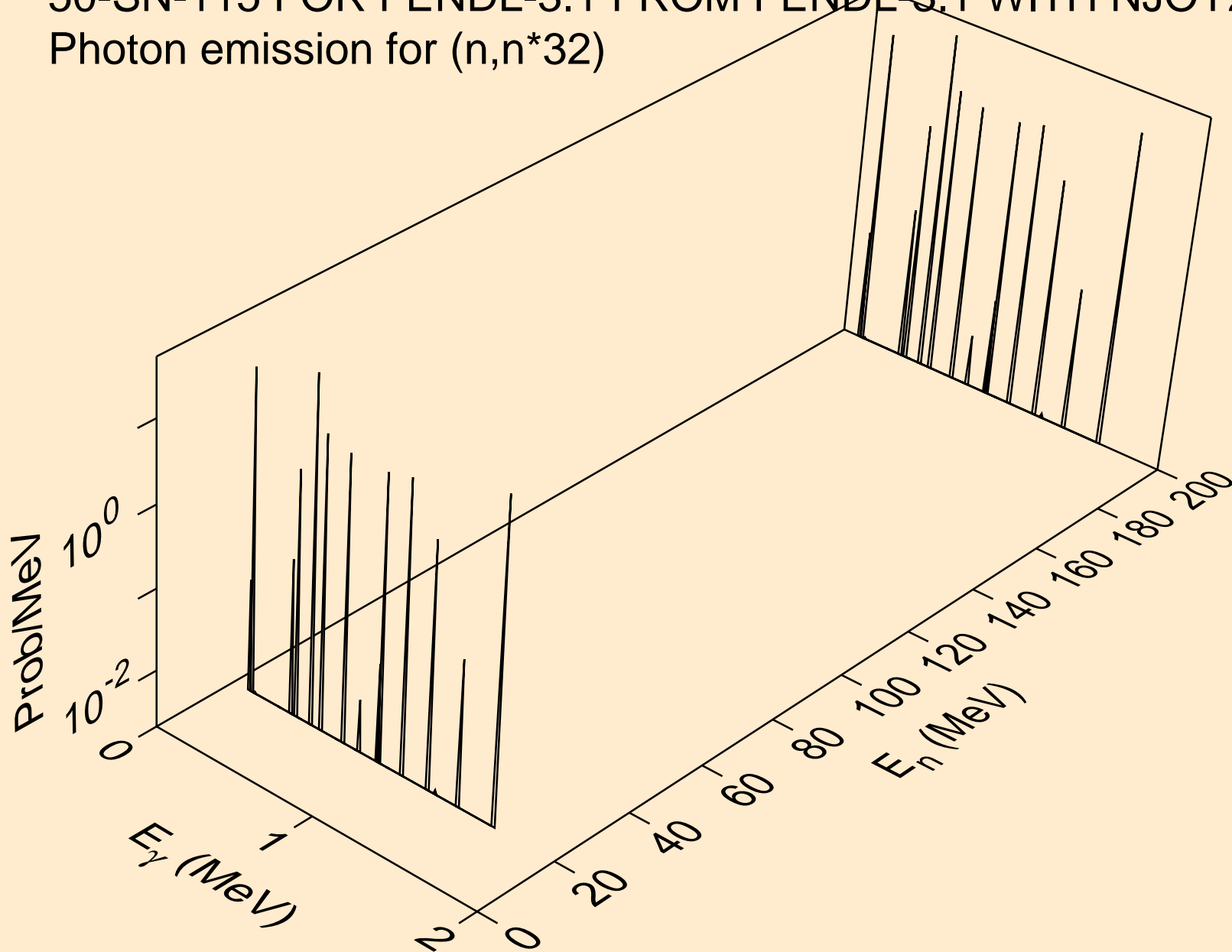



50-SN-115 FOR FENDL-3.1 FROM FENDL-3.1 WITH NJOY2012.50  
Photon emission for (n,n\*33)

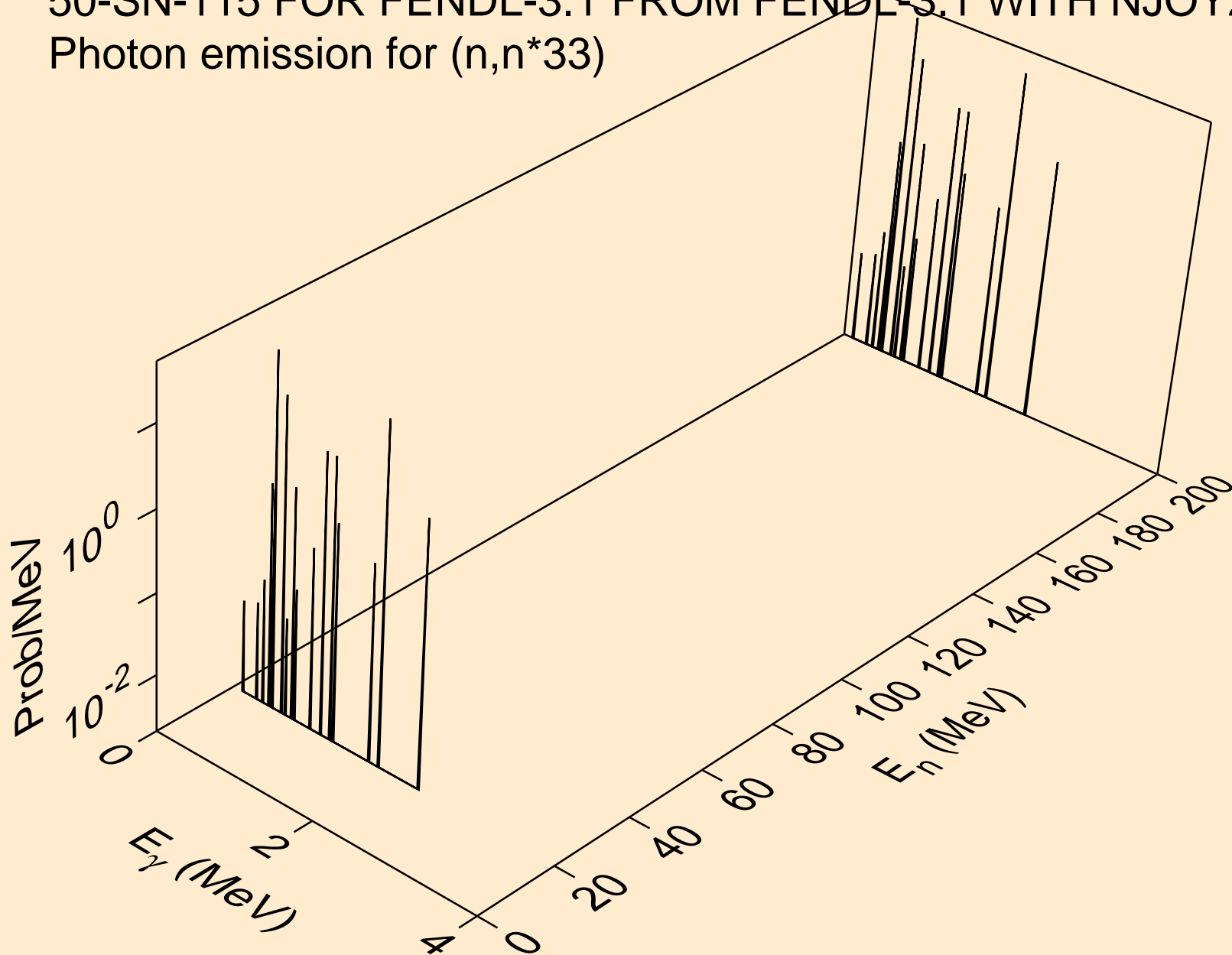

50-SN-115 FOR FENDL-3.1 FROM FENDL-3.1 WITH NJOY2012.50  
Photon emission for (n,n\*34)

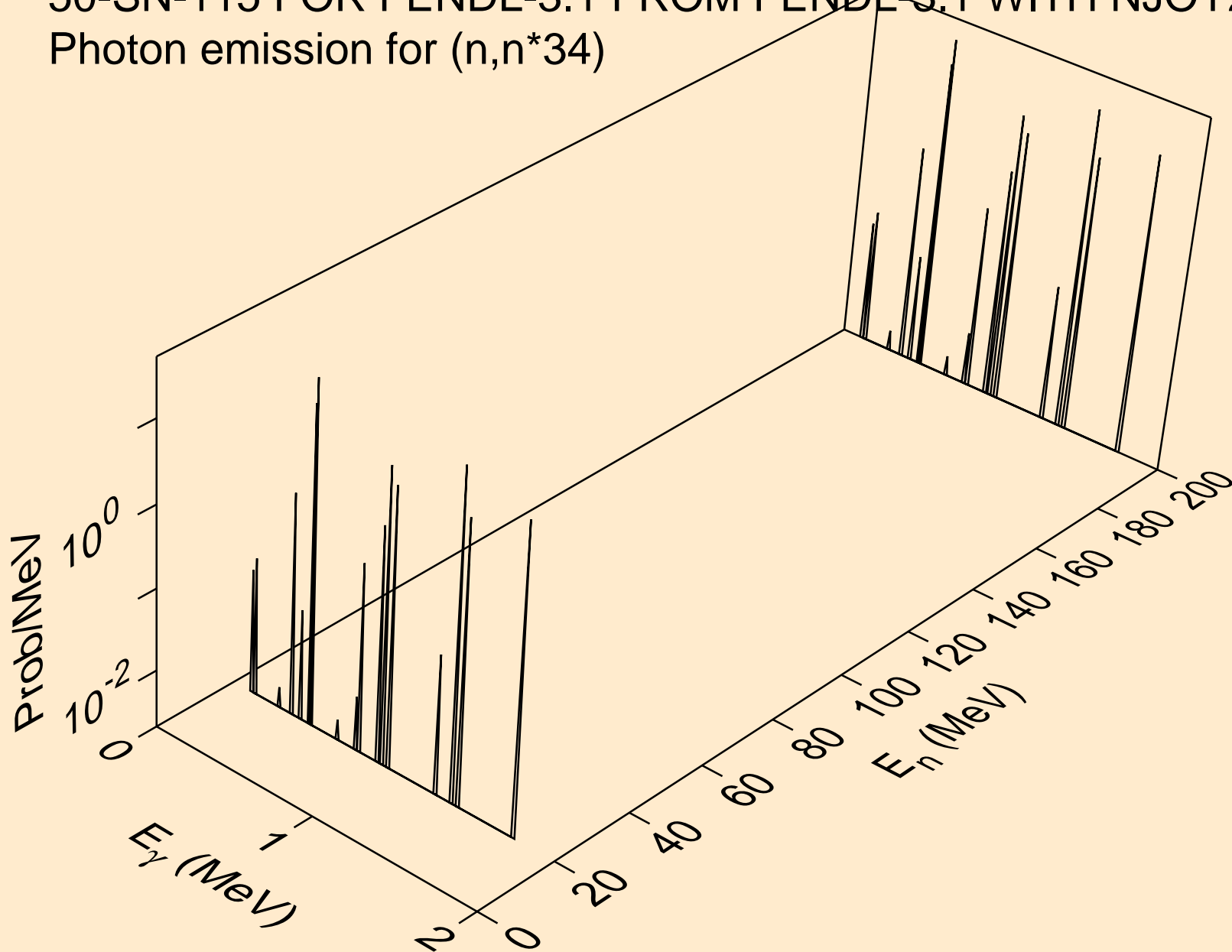

50-SN-115 FOR FENDL-3.1 FROM FENDL-3.1 WITH NJOY2012.50  
Photon emission for (n,n\*35)

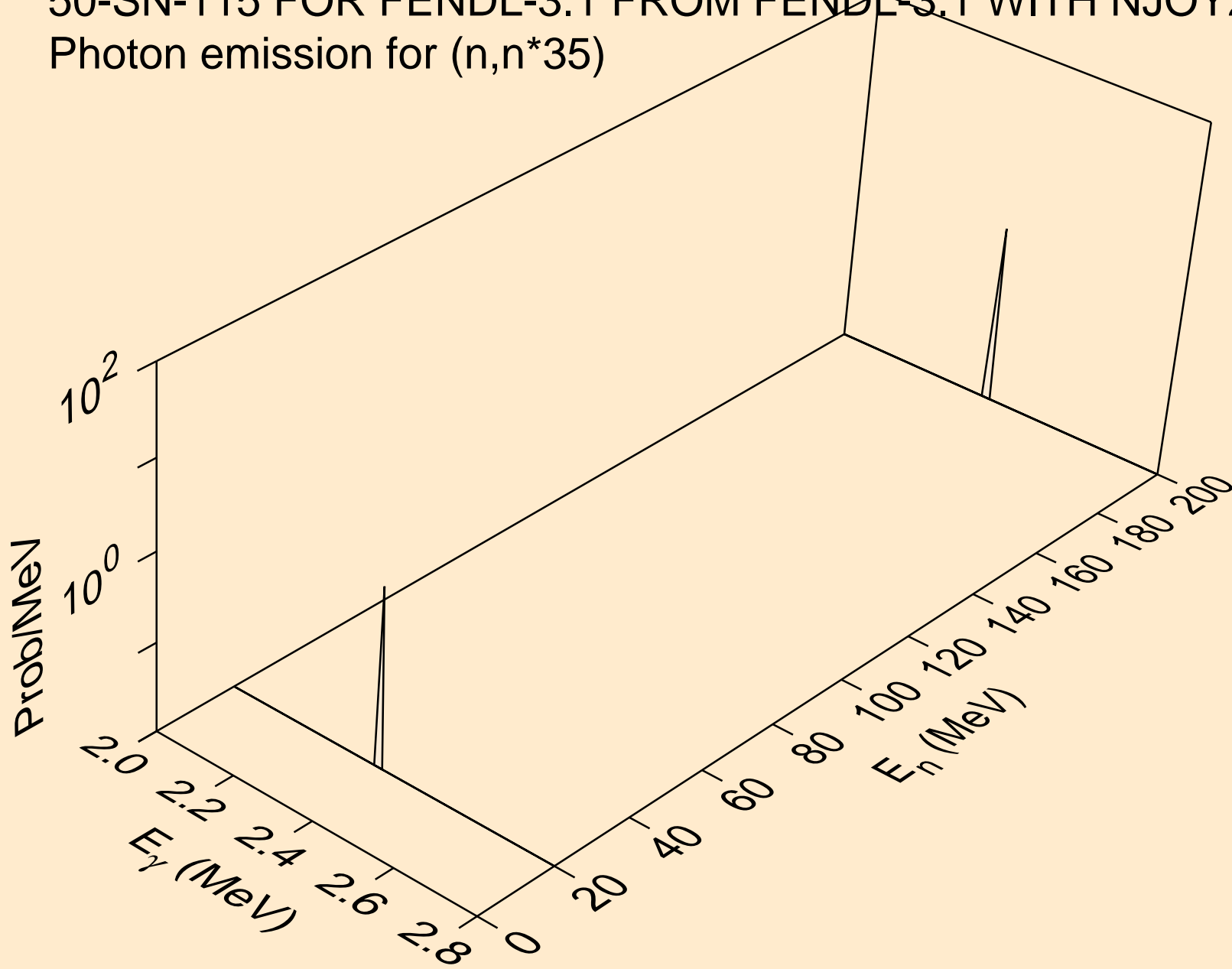

50-SN-115 FOR FENDL-3.1 FROM FENDL-3.1 WITH NJOY2012.50  
Photon emission for (n,n\*c)

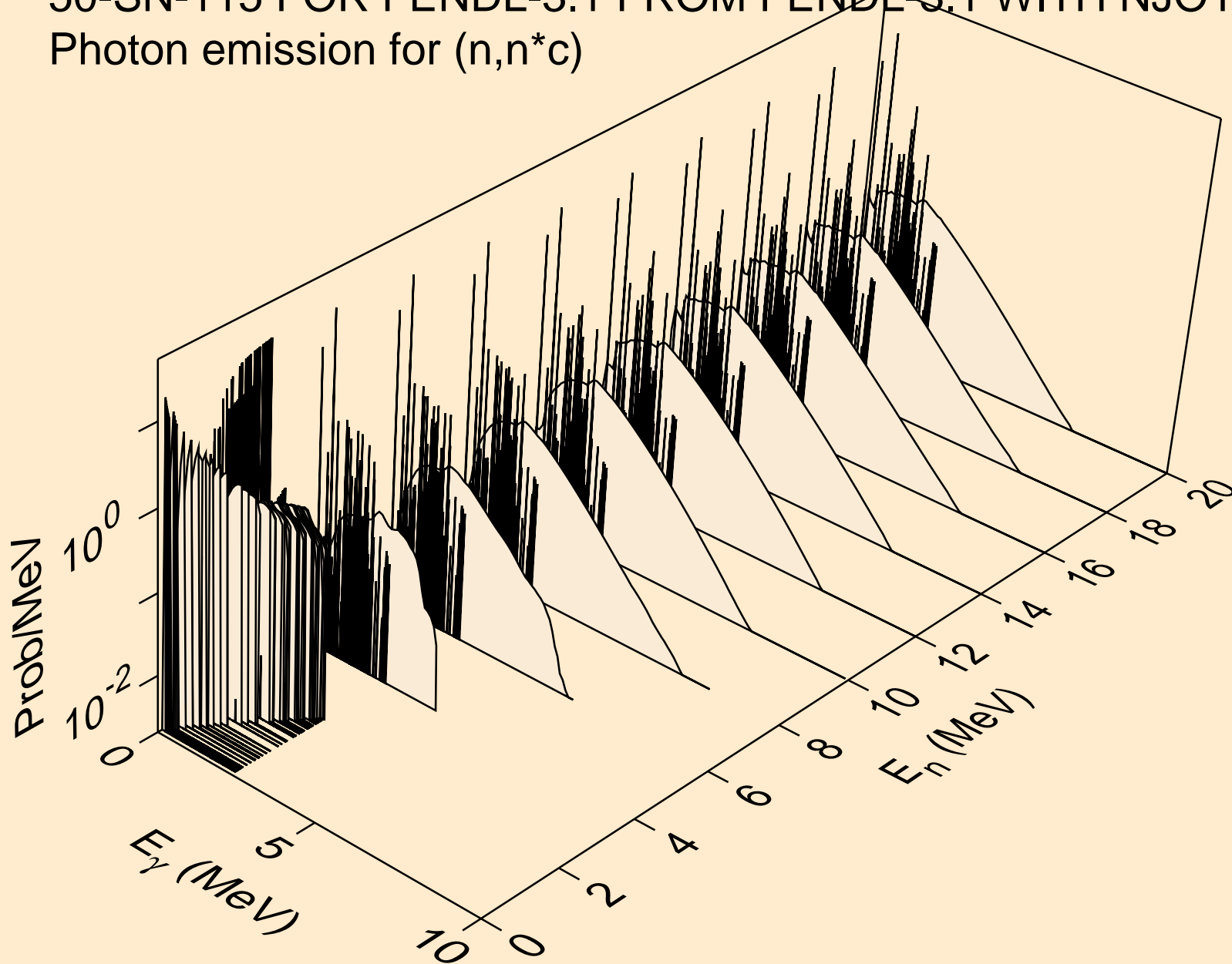

50-SN-115 FOR FENDL-3.1 FROM FENDL-3.1 WITH NJOY2012.50  
Photon emission for (n,gma)

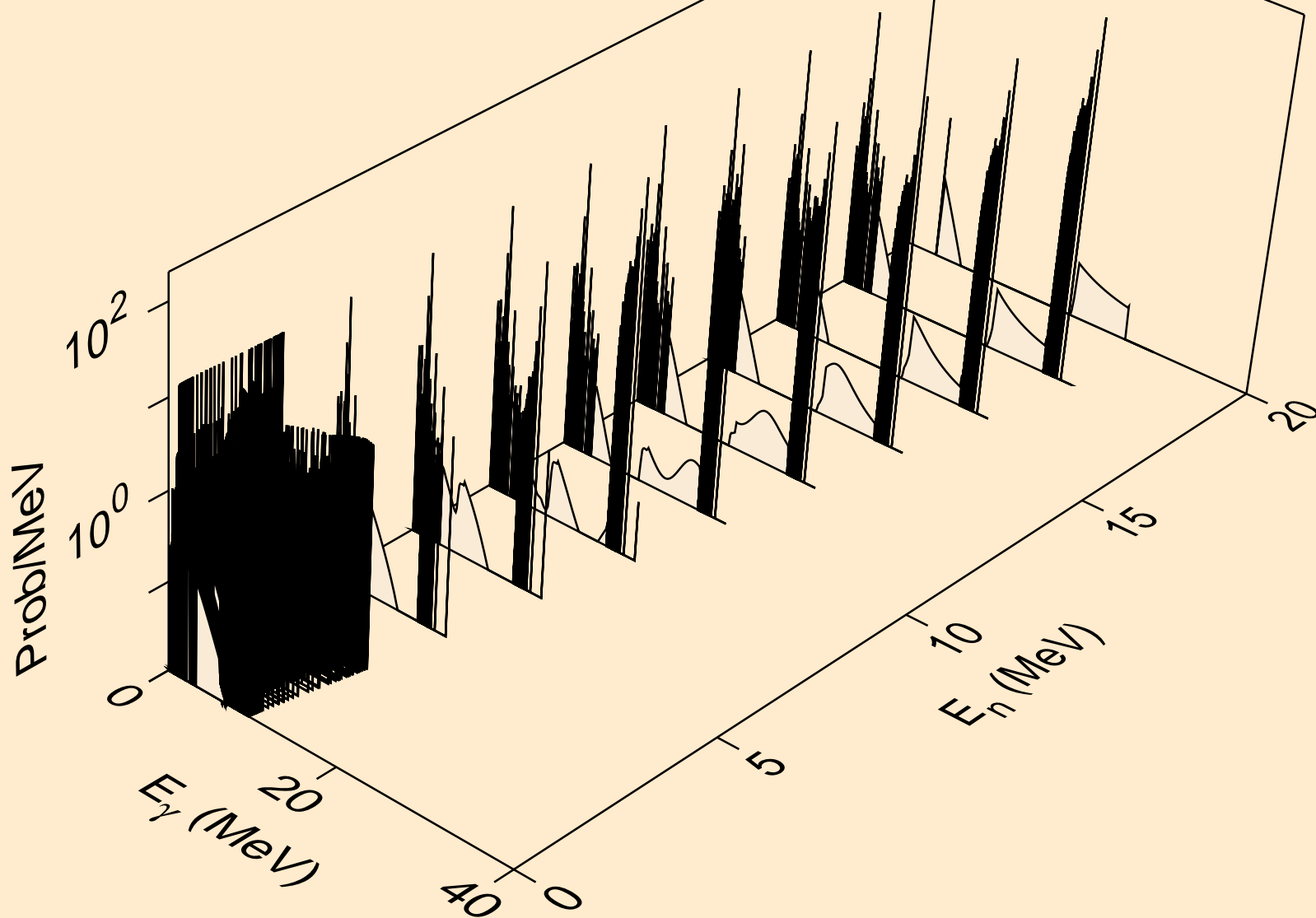

50-SN-115 FOR FENDL-3.1 FROM FENDL-3.1 WITH NJOY2012.50  
thermal capture photon spectrum

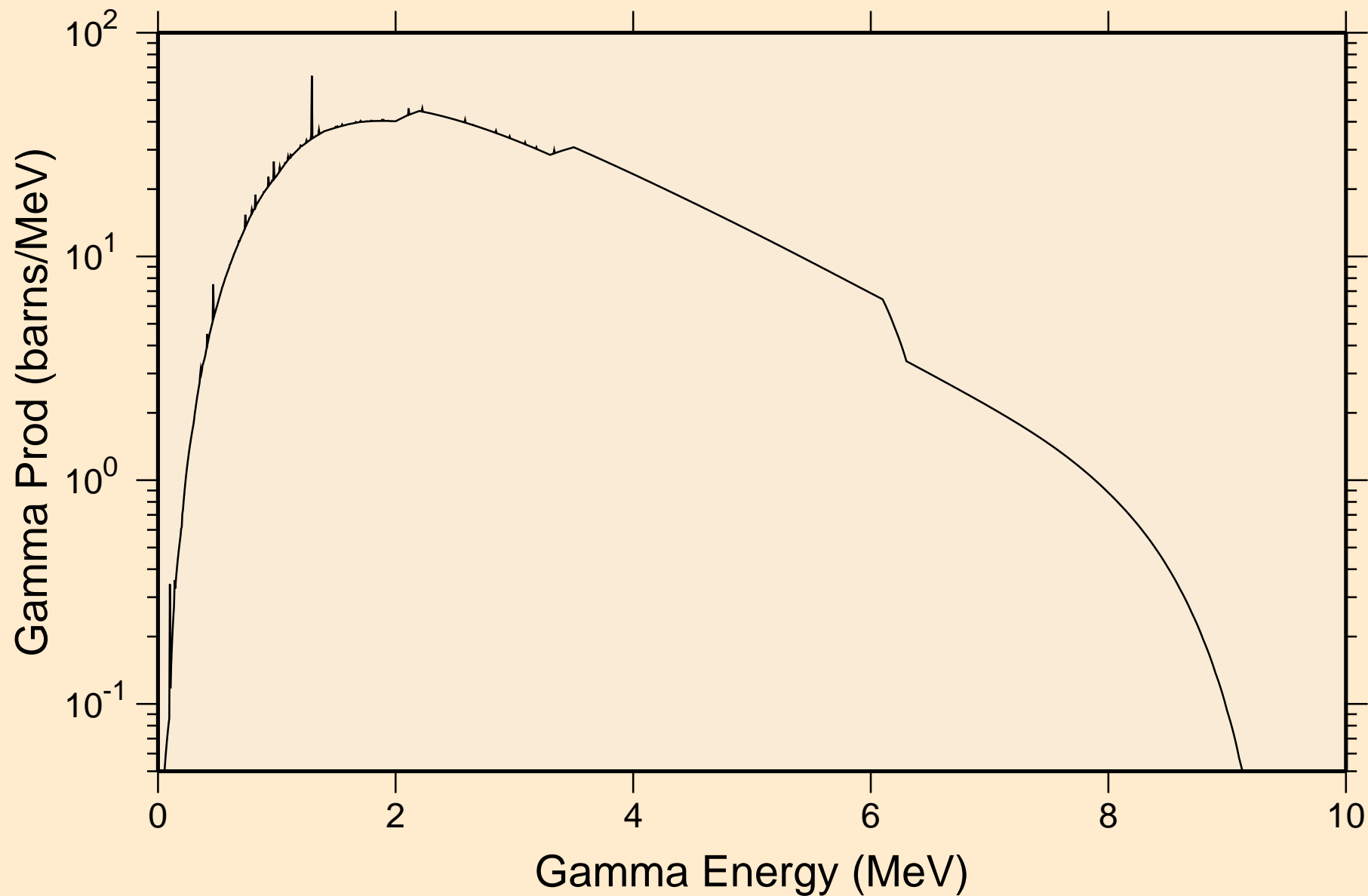

50-SN-115 FOR FENDL-3.1 FROM FENDL-3.1 WITH NJOY2012.50  
14 MeV photon spectrum

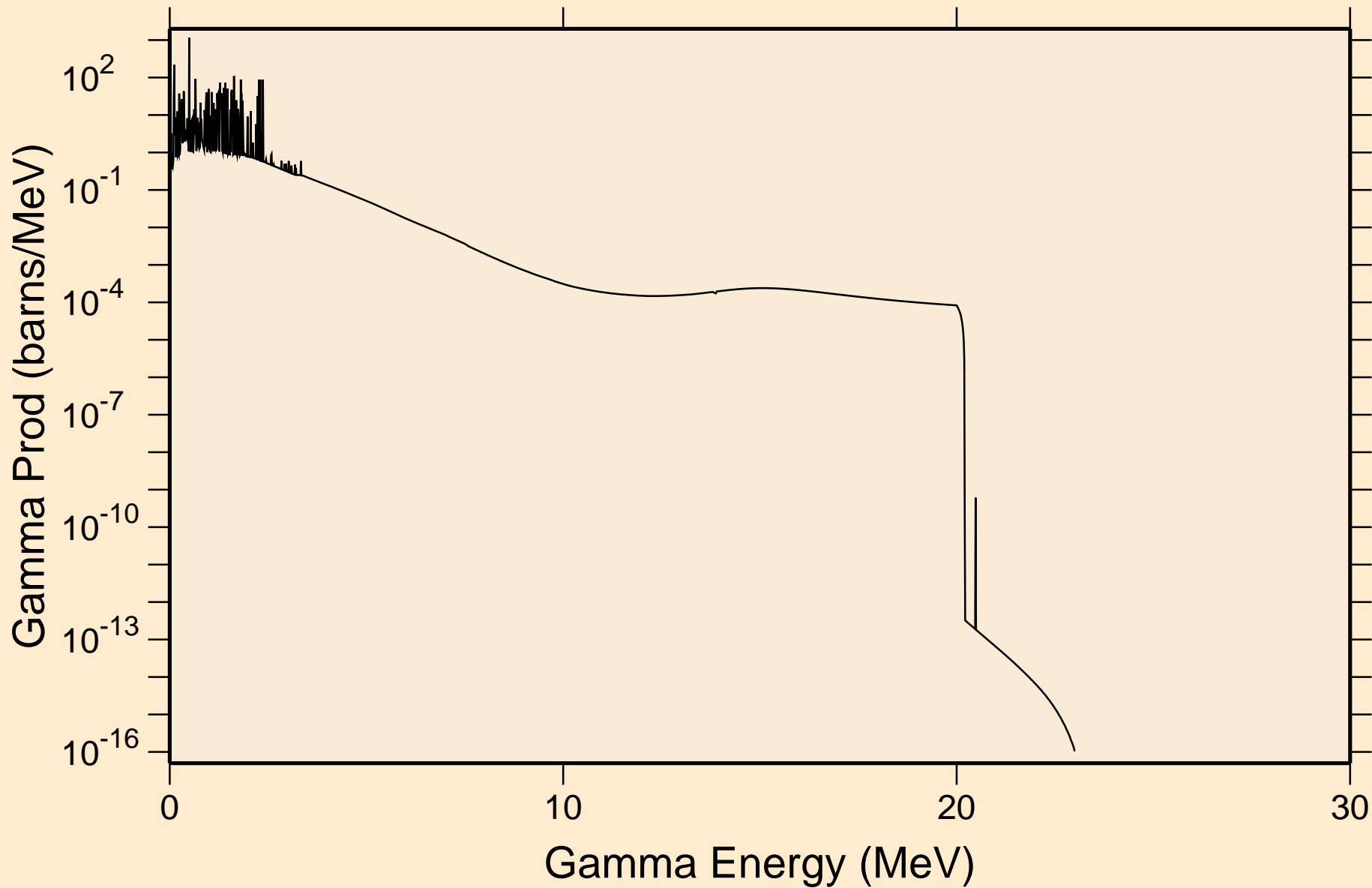

# 50-SN-115 FOR FENDL-3.1 FROM FENDL-3.1 WITH NJOY2012.50

## Particle heating contributions

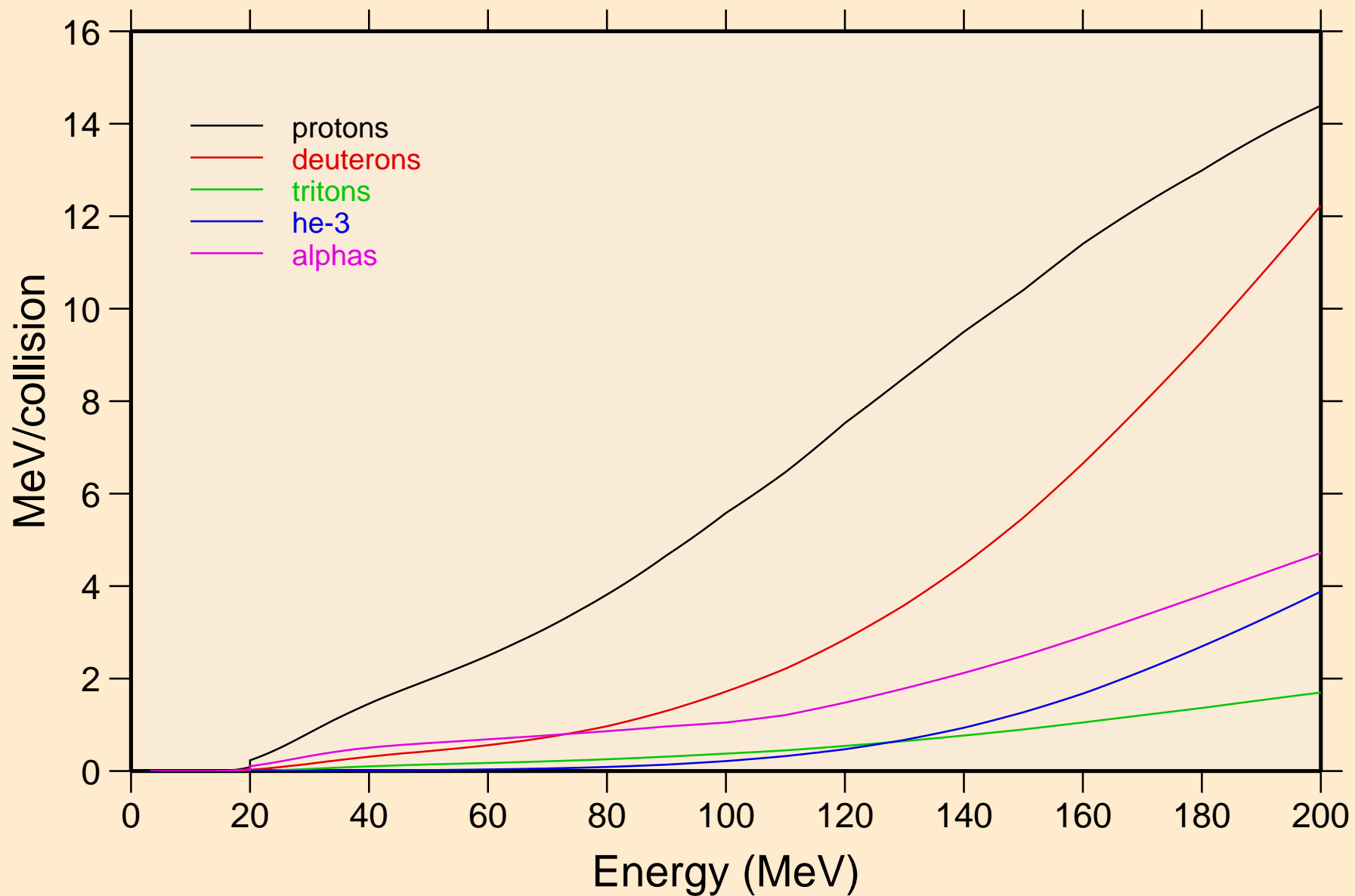



# 50-SN-115 FOR FENDL-3.1 FROM FENDL-3.1 WITH NJOY2012.50

## Recoil Heating

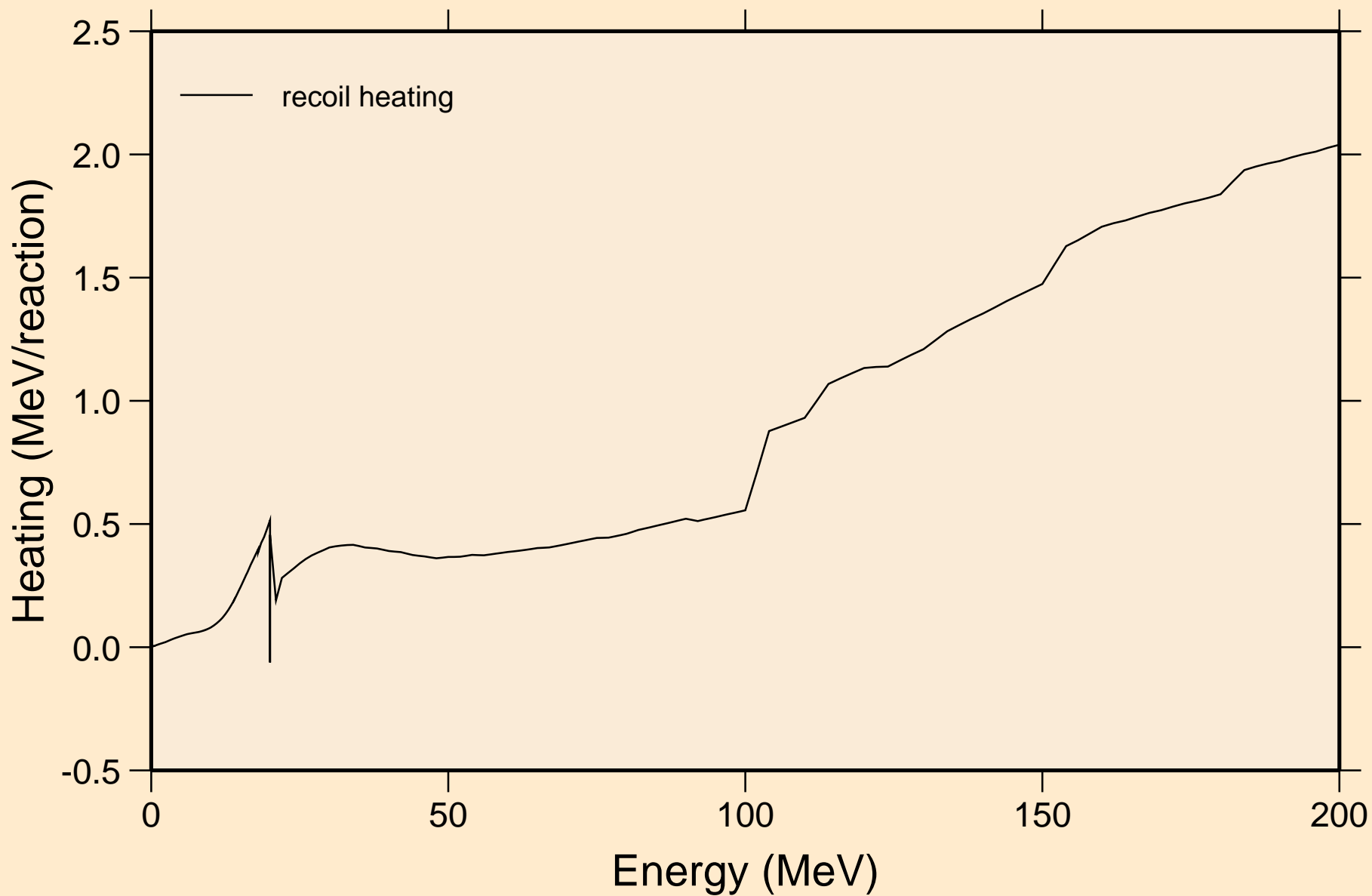

# 50-SN-115 FOR FENDL-3.1 FROM FENDL-3.1 WITH NJOY2012.50

## Particle production cross sections

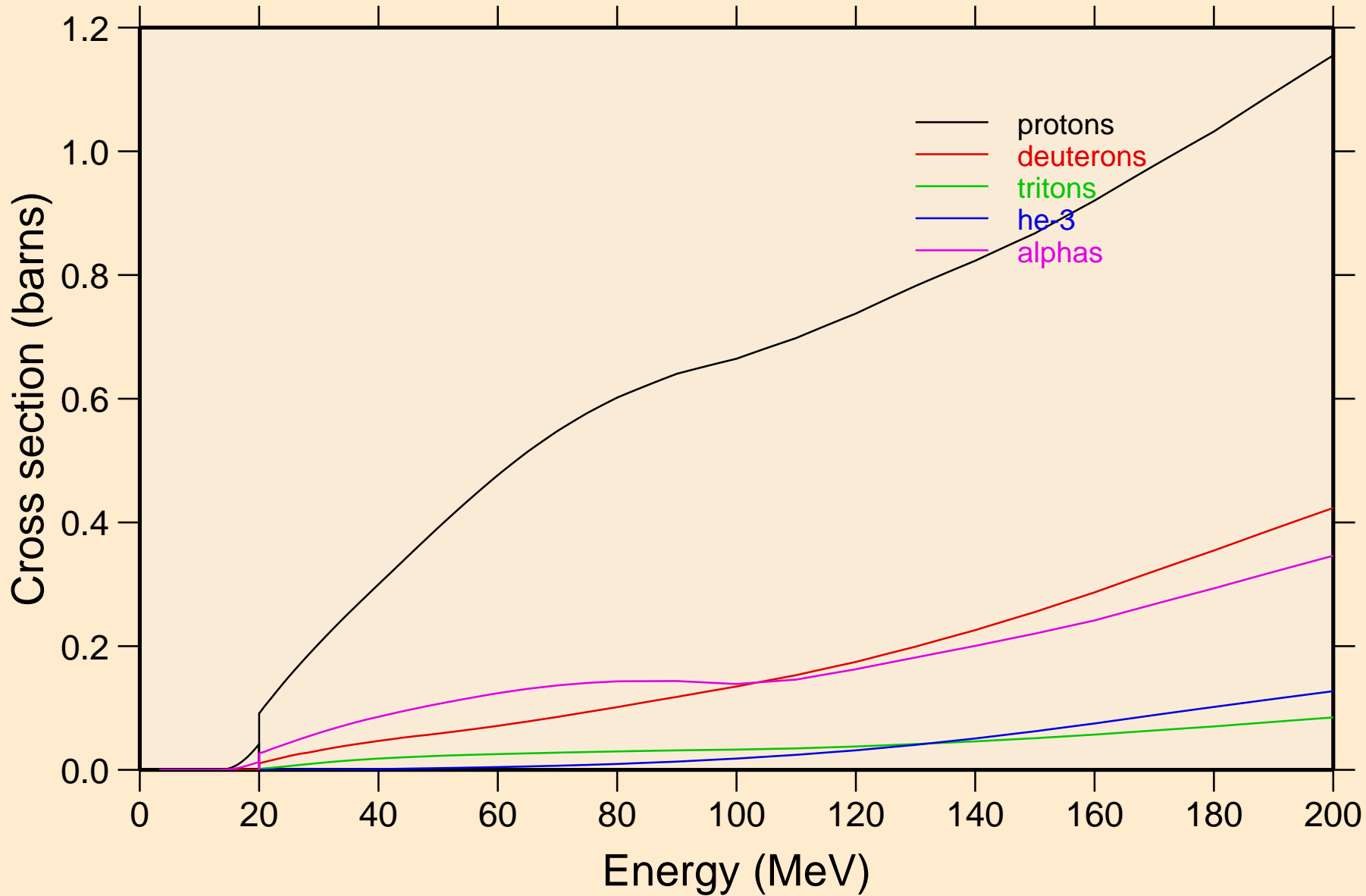

50-SN-115 FOR FENDL-3.1 FROM FENDL-3.1 WITH NJOY2012.50  
protons from (n,x)

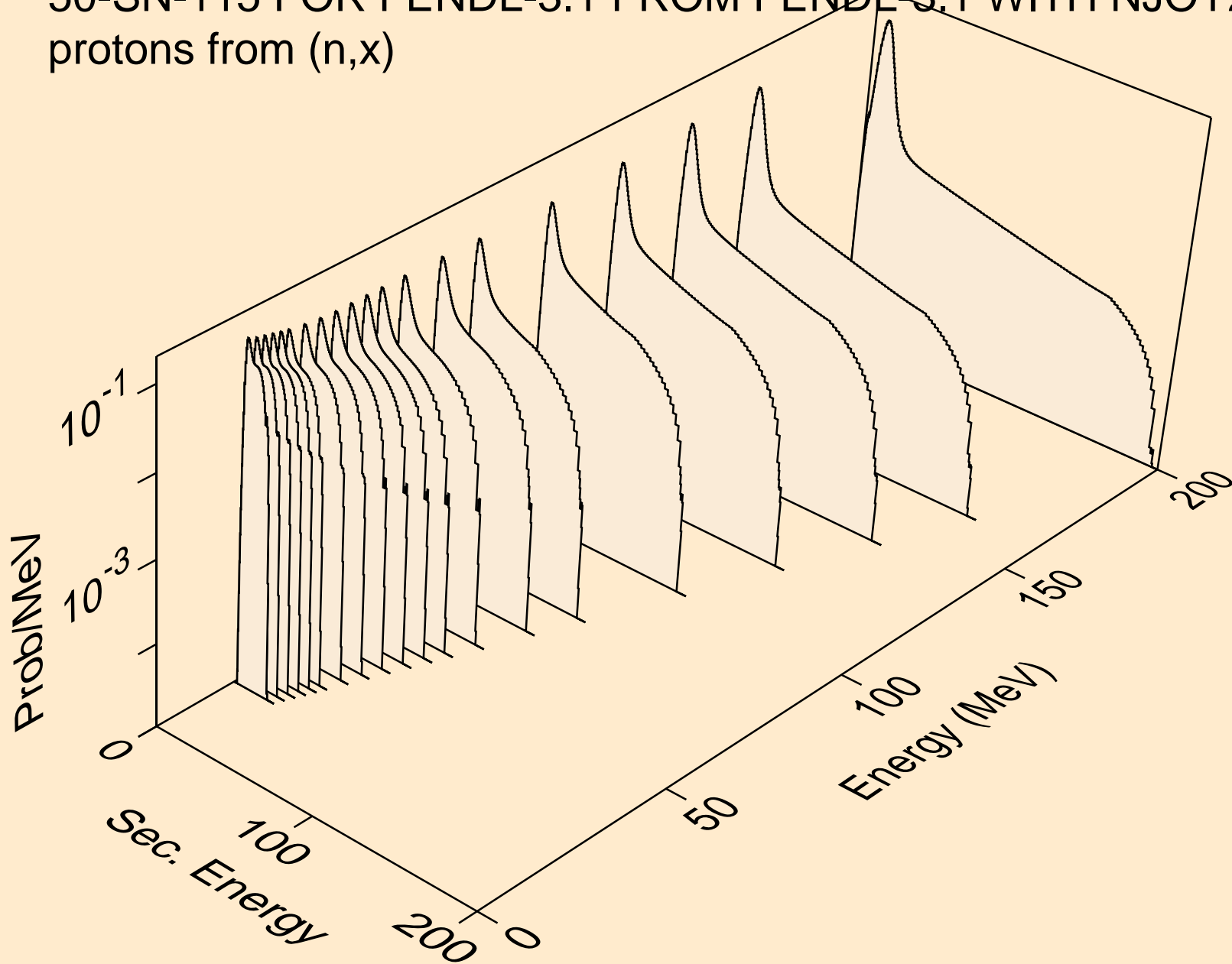

50-SN-115 FOR FENDL-3.1 FROM FENDL-3.1 WITH NJOY2012.50  
protons from (n,n\*)p

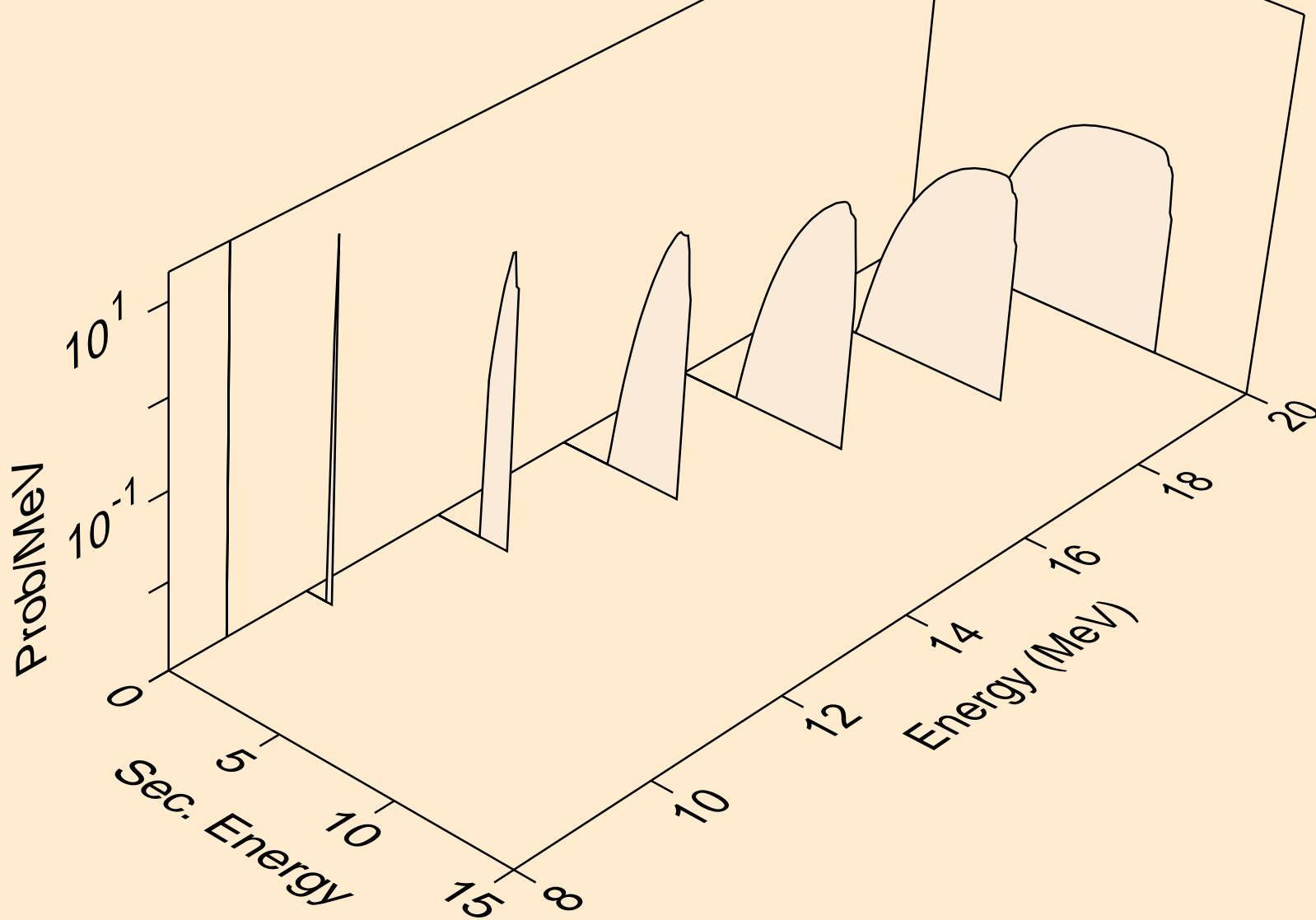

50-SN-115 FOR FENDL-3.1 FROM FENDL-3.1 WITH NJOY2012.50  
protons from (n,2np)

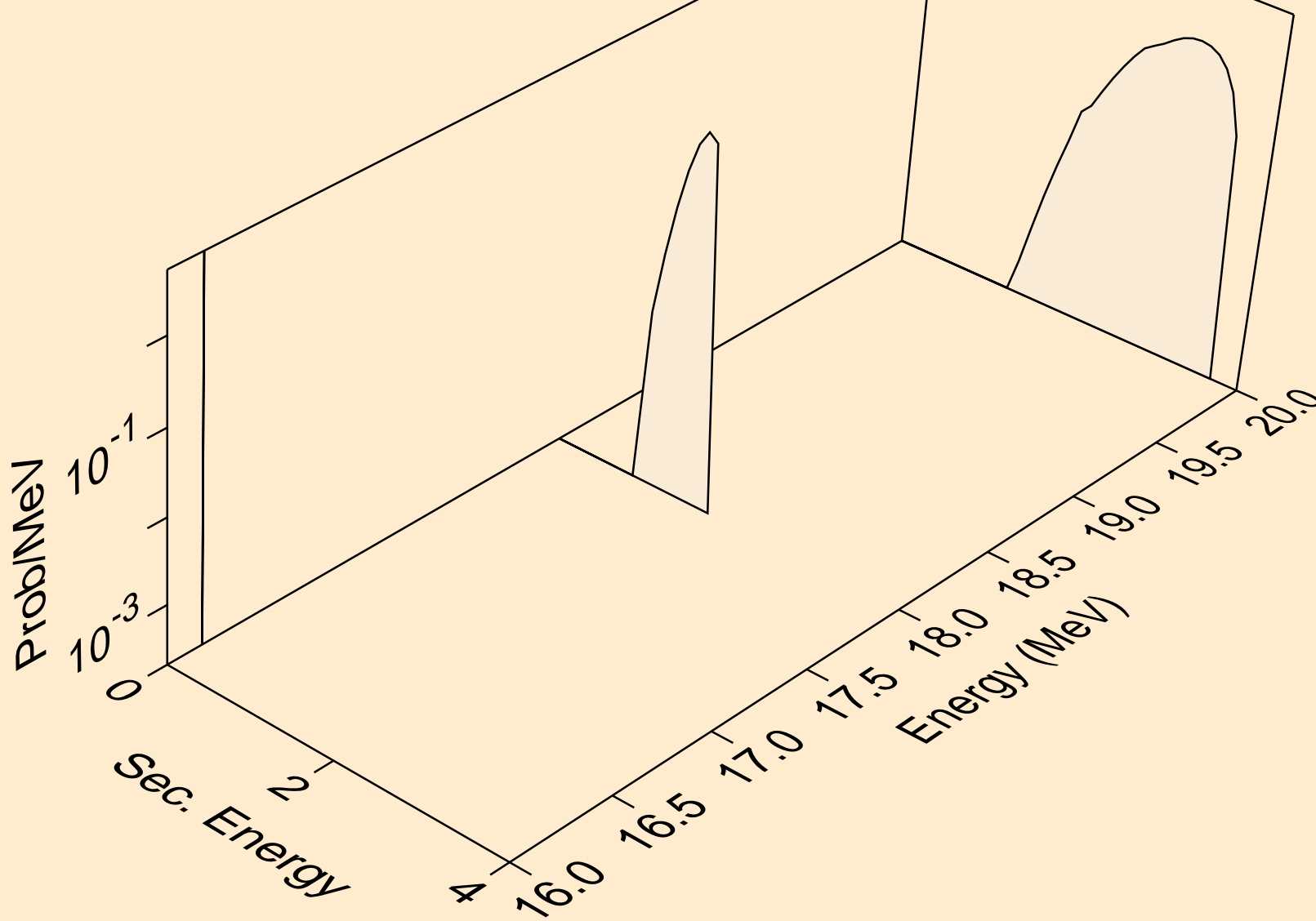

50-SN-115 FOR FENDL-3.1 FROM FENDL-3.1 WITH NJOY2012.50  
deuterons from (n,x)

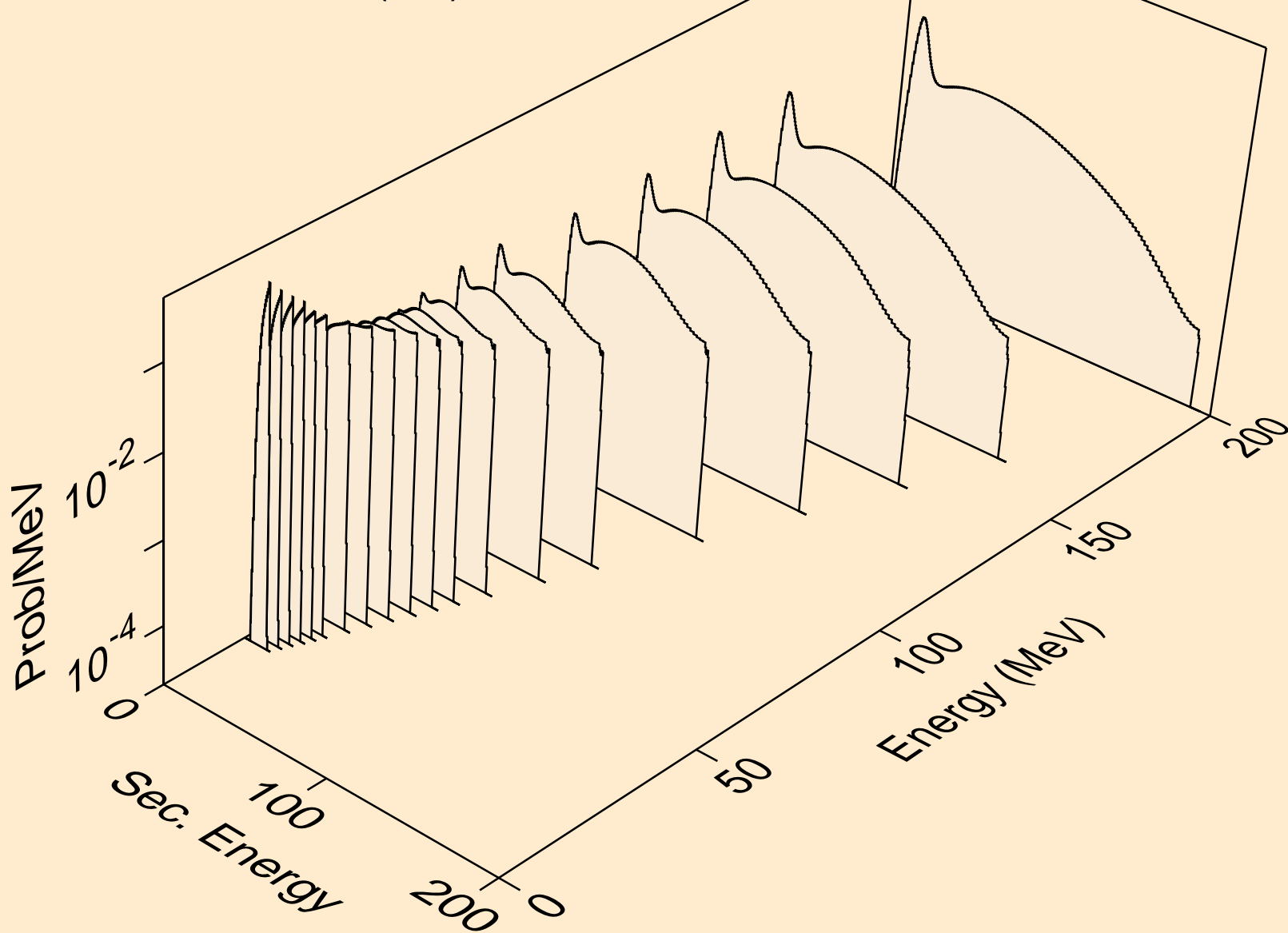

50-SN-115 FOR FENDL-3.1 FROM FENDL-3.1 WITH NJOY2012.50  
deuterons from (n,n\*)d

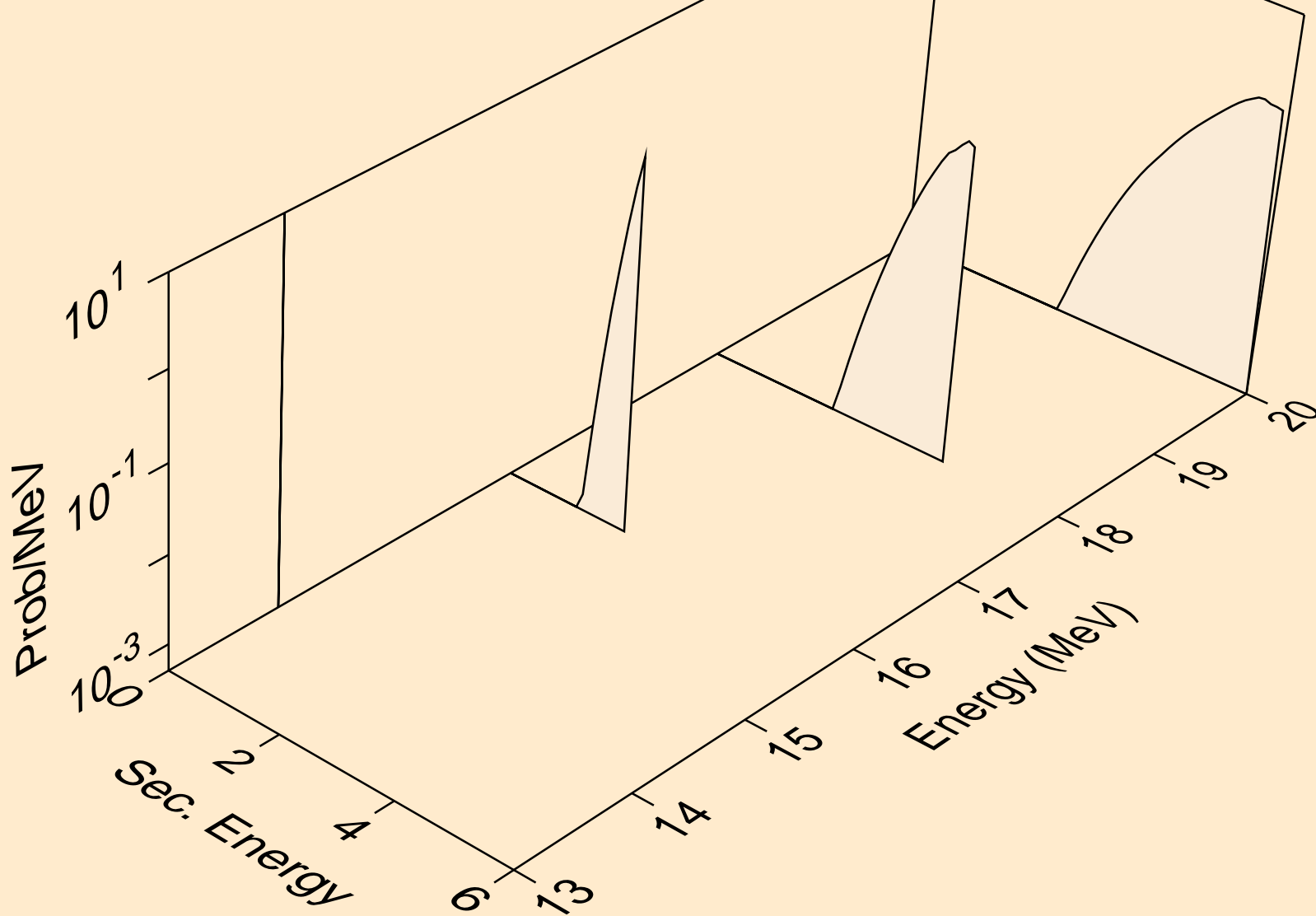

50-SN-115 FOR FENDL-3.1 FROM FENDL-3.1 WITH NJOY2012.50  
tritons from (n,x)

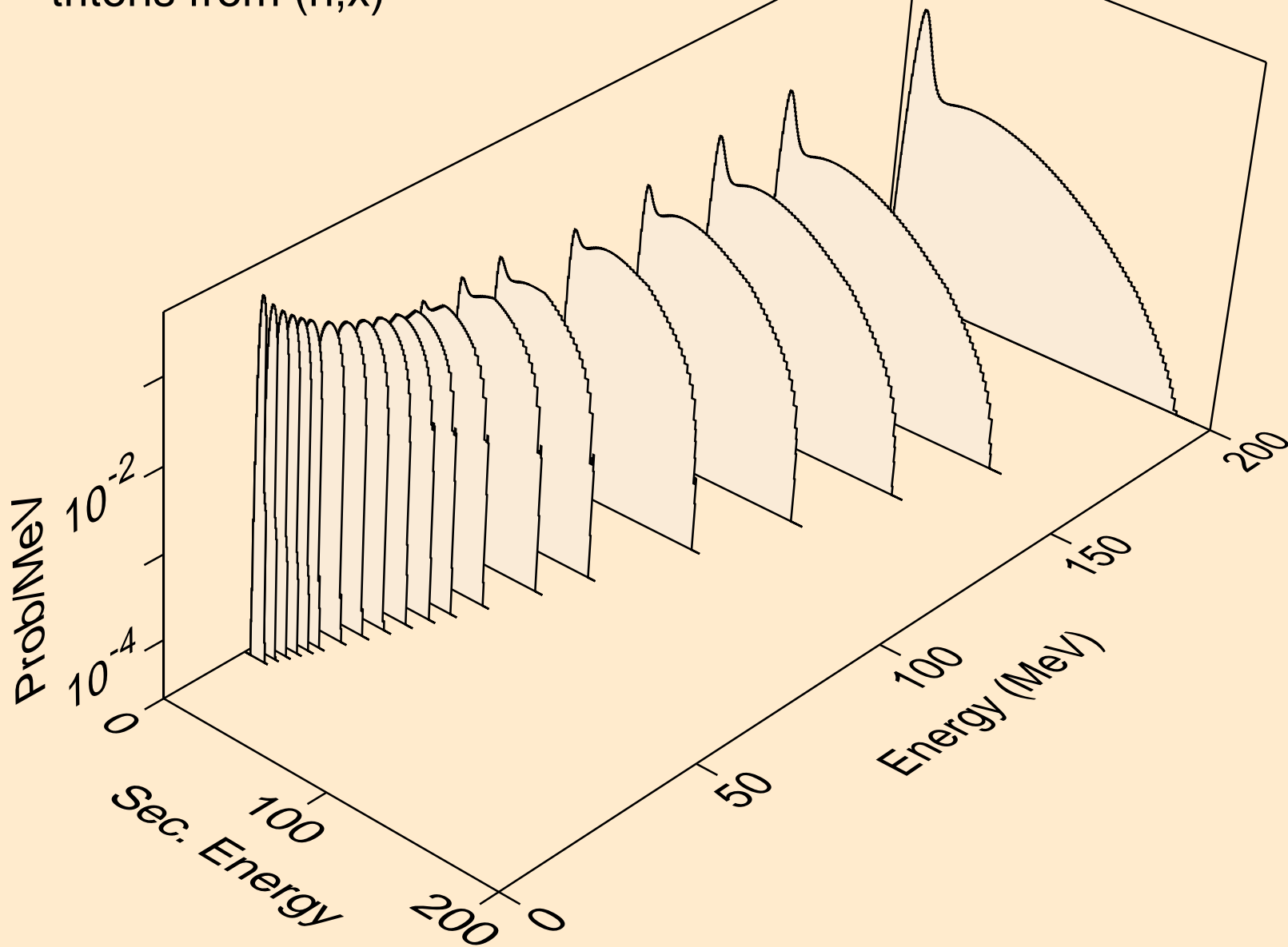



50-SN-115 FOR FENDL-3.1 FROM FENDL-3.1 WITH NJOY2012.50  
he3s from (n,x)

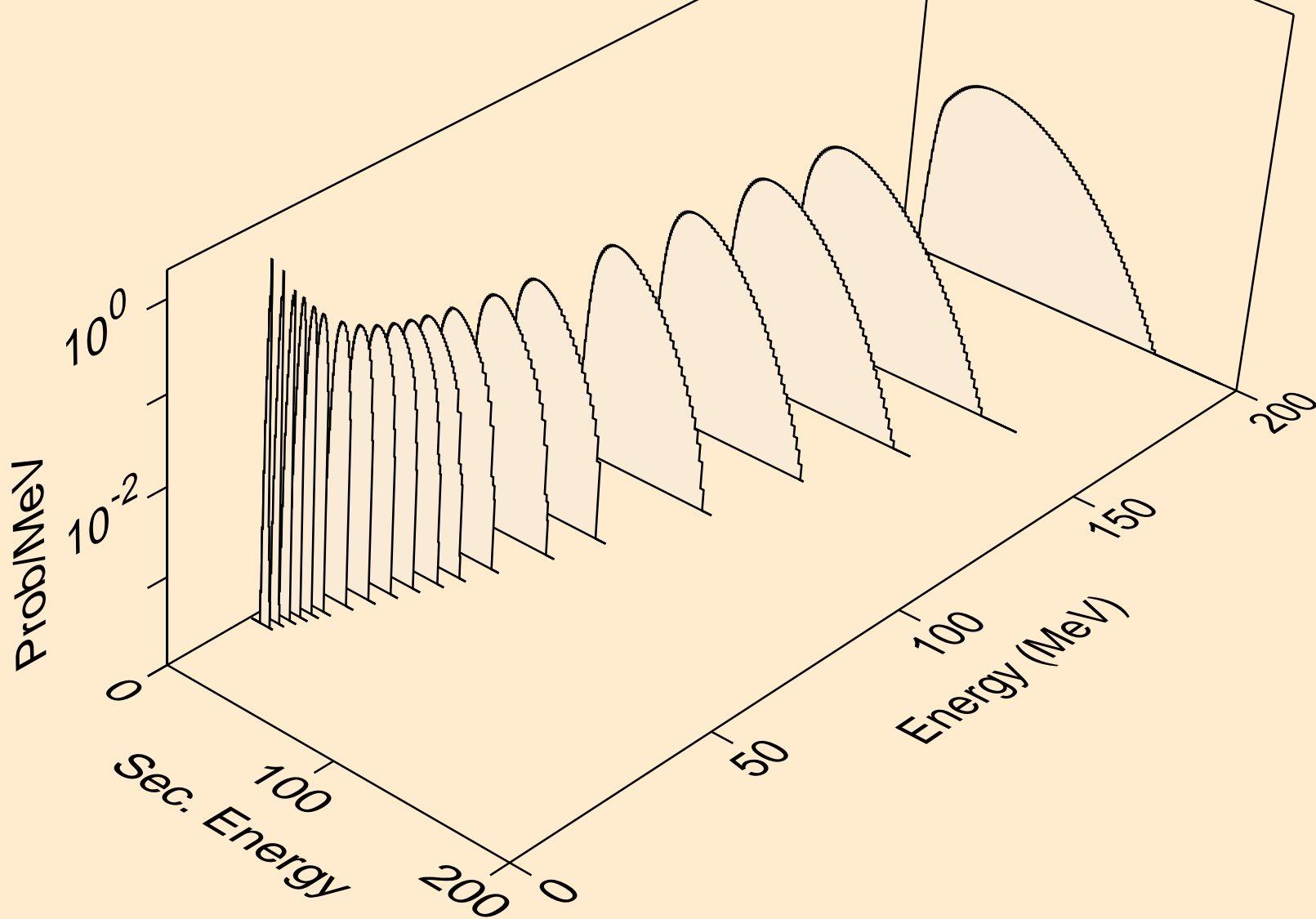

50-SN-115 FOR FENDL-3.1 FROM FENDL-3.1 WITH NJOY2012.50  
alphas from (n,x)

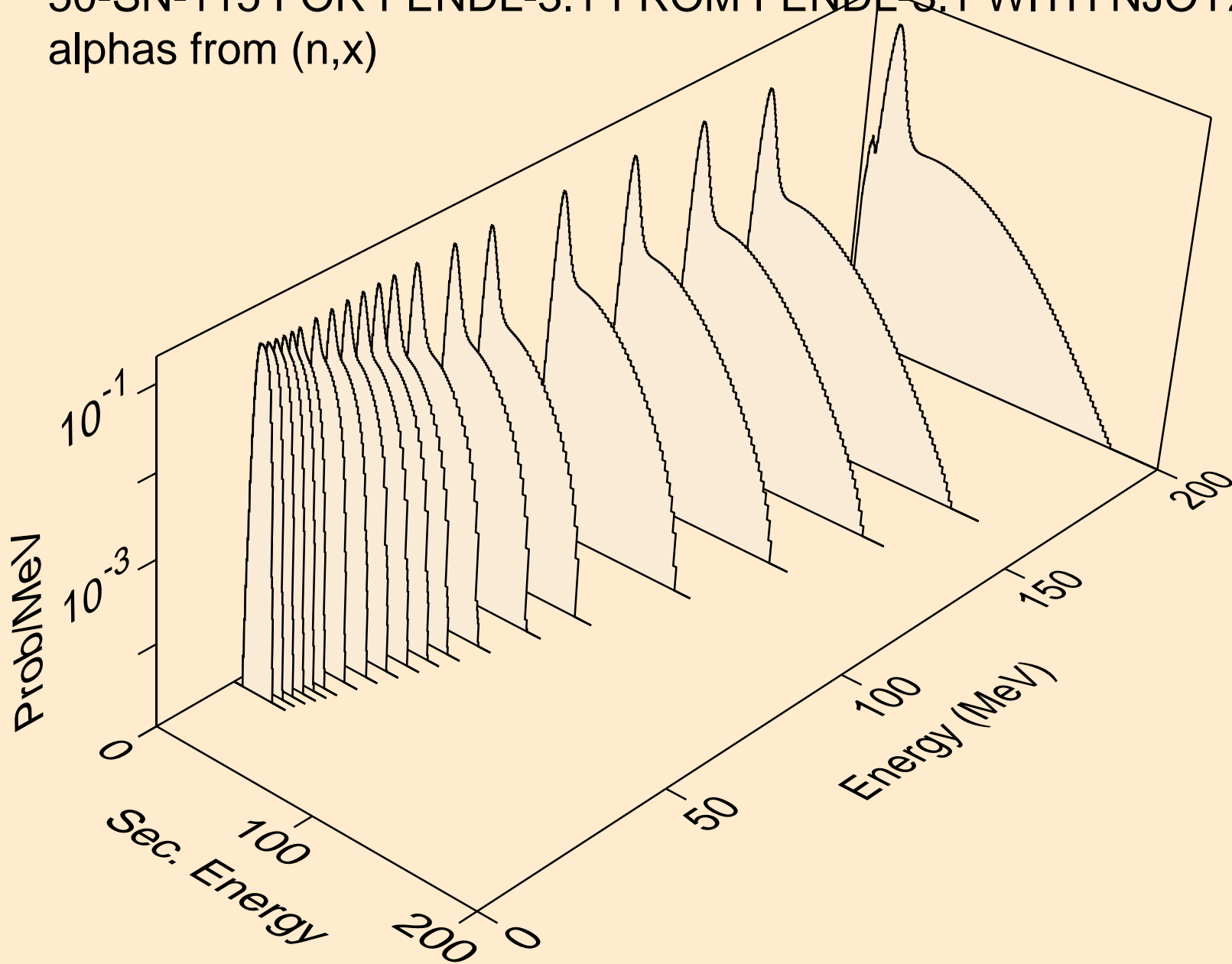

50-SN-115 FOR FENDL-3.1 FROM FENDL-3.1 WITH NJOY2012.50  
alphas from (n,n\*)a

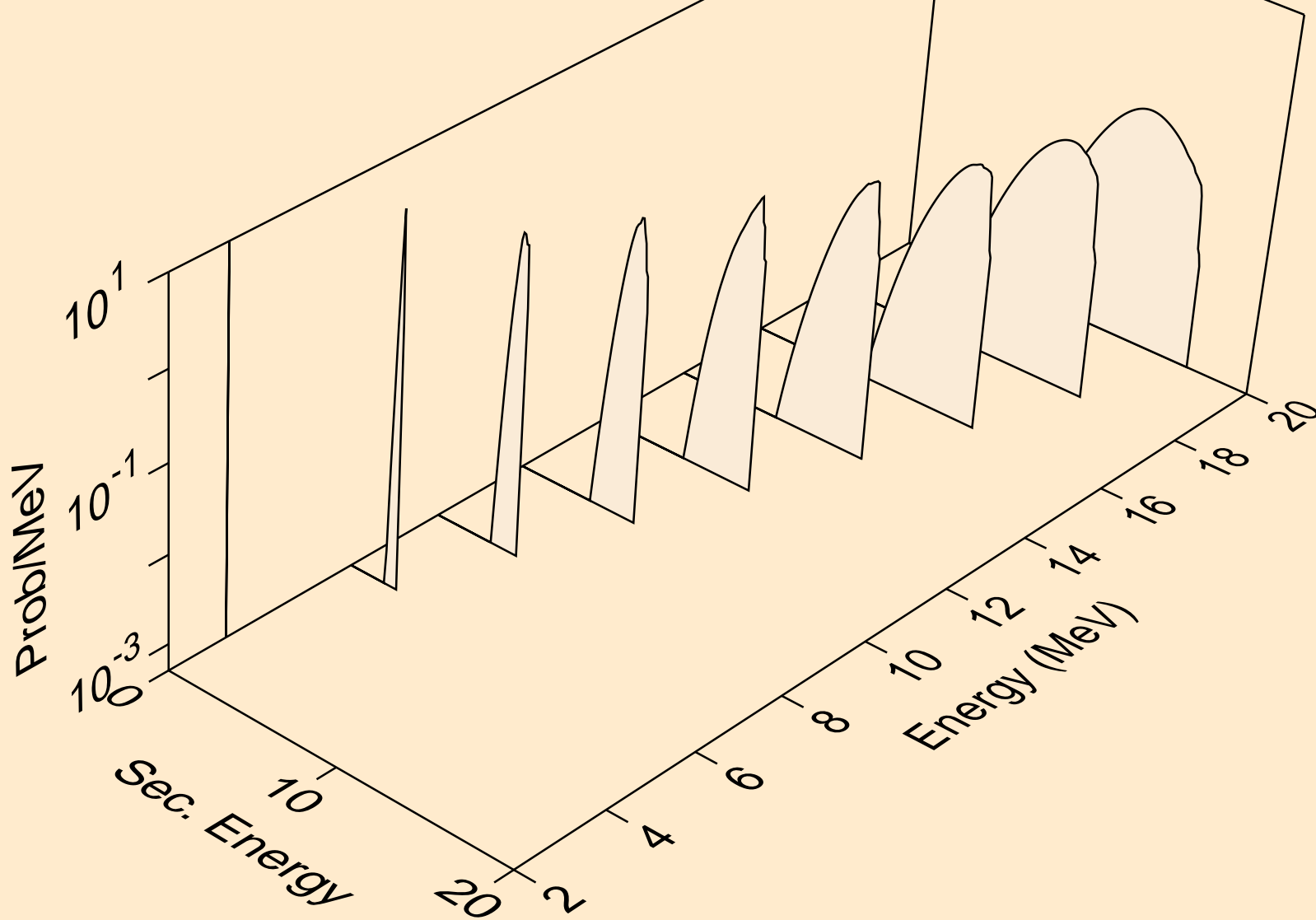

50-SN-115 FOR FENDL-3.1 FROM FENDL-3.1 WITH NJOY2012.50  
alphas from (n,2n)a

