

# 53-I-127 FOR FENDL-3.1 FROM FENDL-3.1 WITH NJOY2012.50+ C

## Principal cross sections

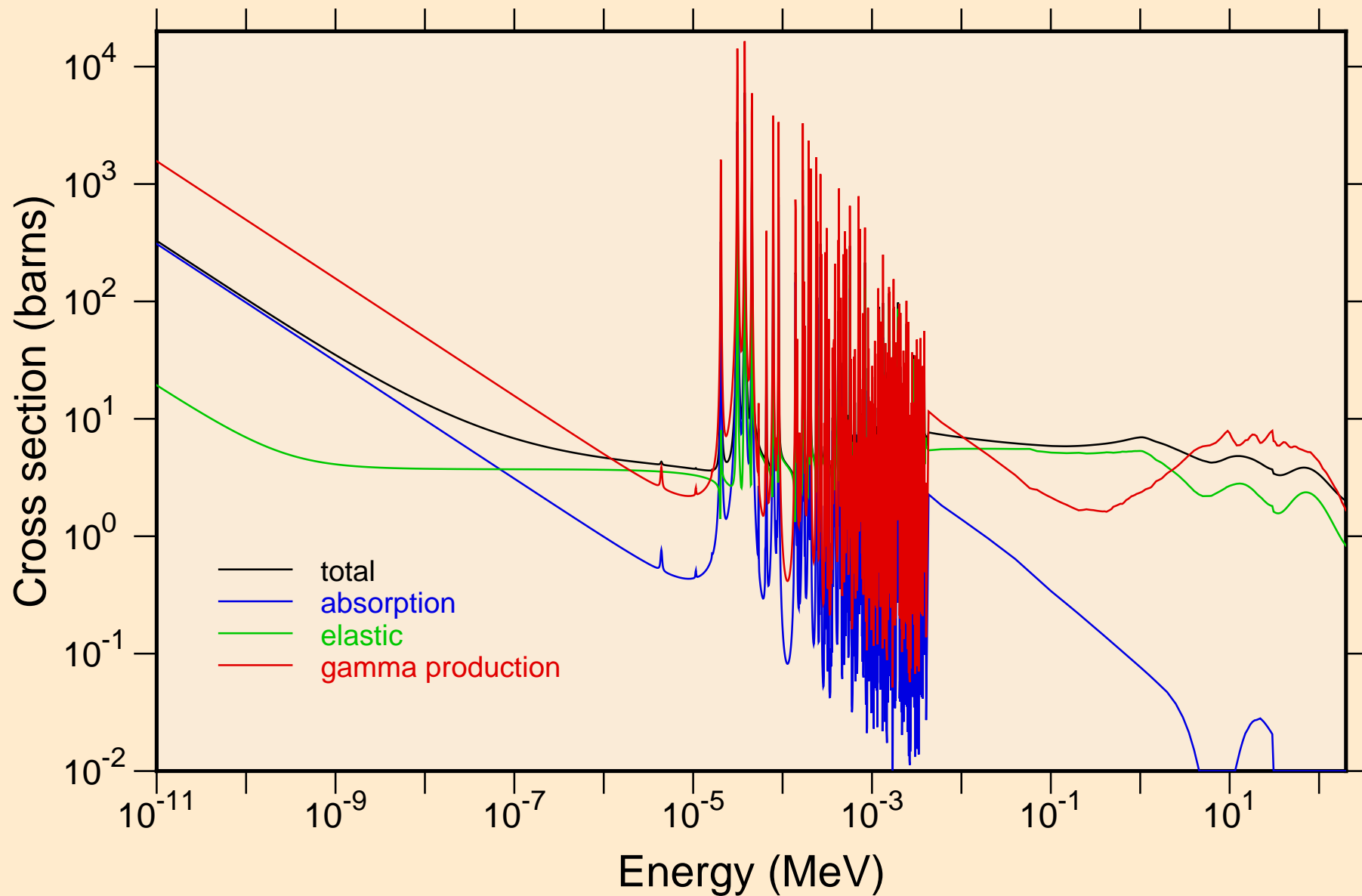

53-I-127 FOR FENDL-3.1 FROM FENDL-3.1 WITH NJOY2012.50+ C  
resonance total cross section

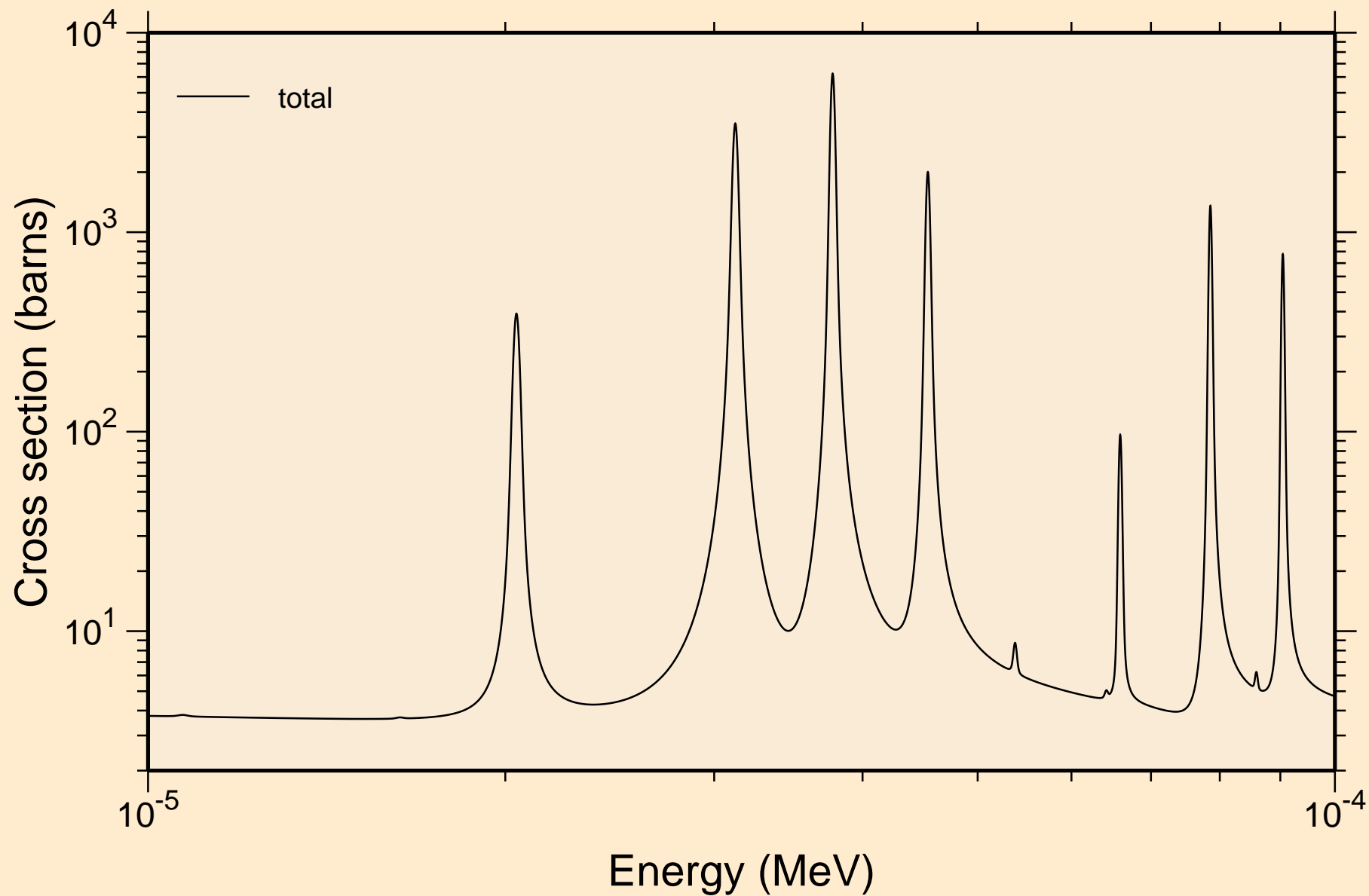

53-I-127 FOR FENDL-3.1 FROM FENDL-3.1 WITH NJOY2012.50+ C  
resonance total cross section

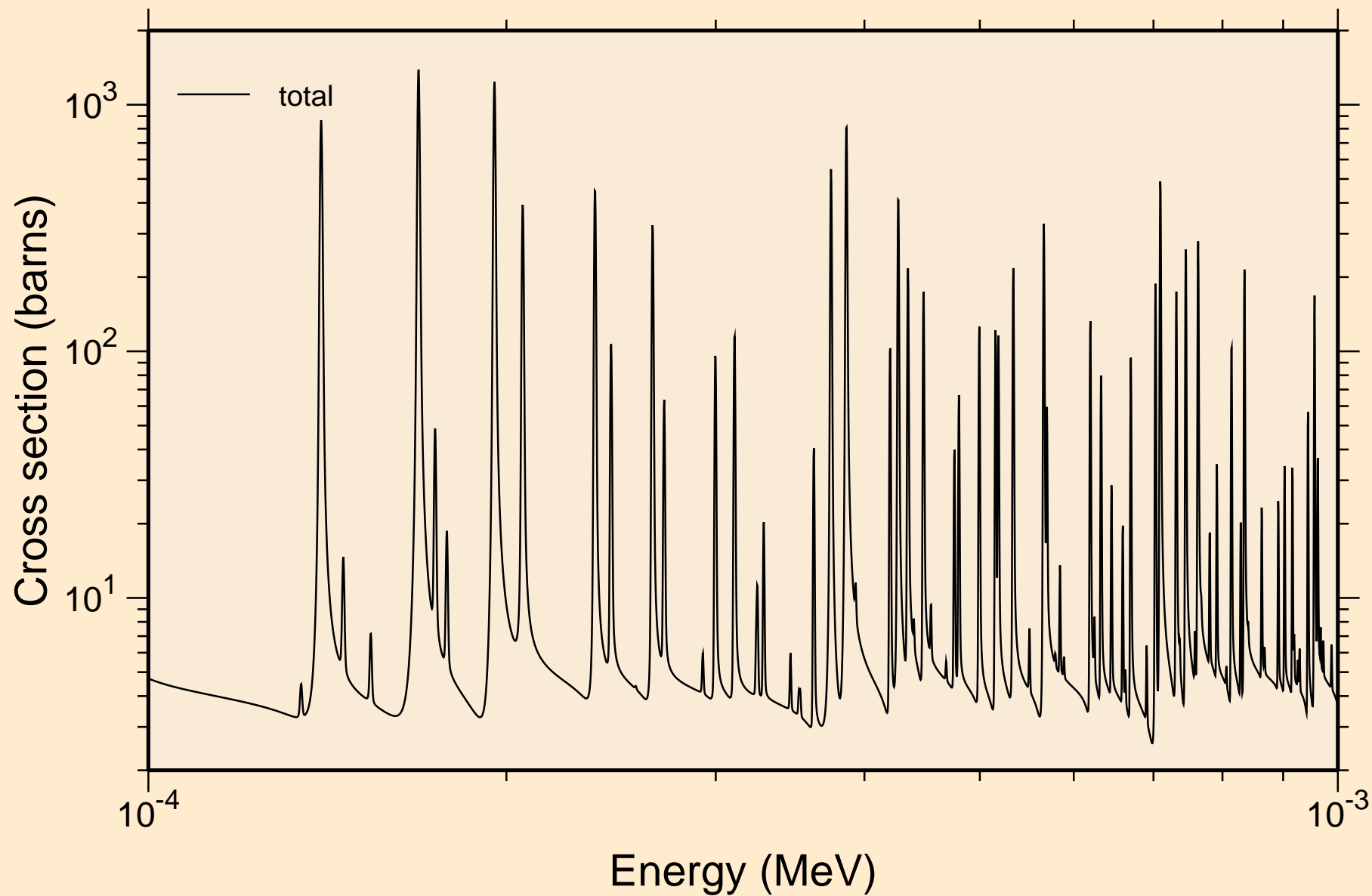

53-I-127 FOR FENDL-3.1 FROM FENDL-3.1 WITH NJOY2012.50+ C  
resonance total cross section

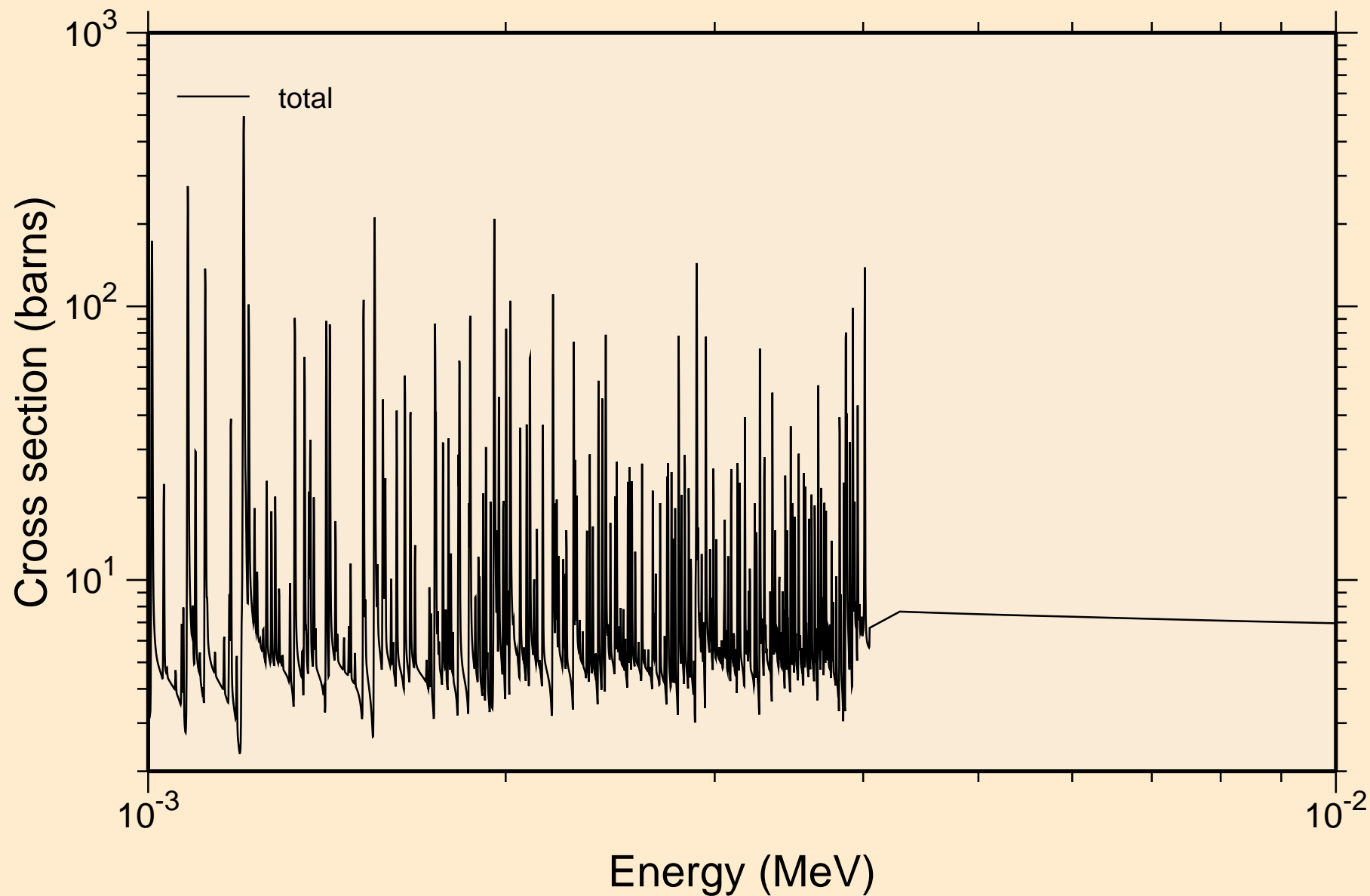

53-I-127 FOR FENDL-3.1 FROM FENDL-3.1 WITH NJOY2012.50+ C  
resonance total cross section

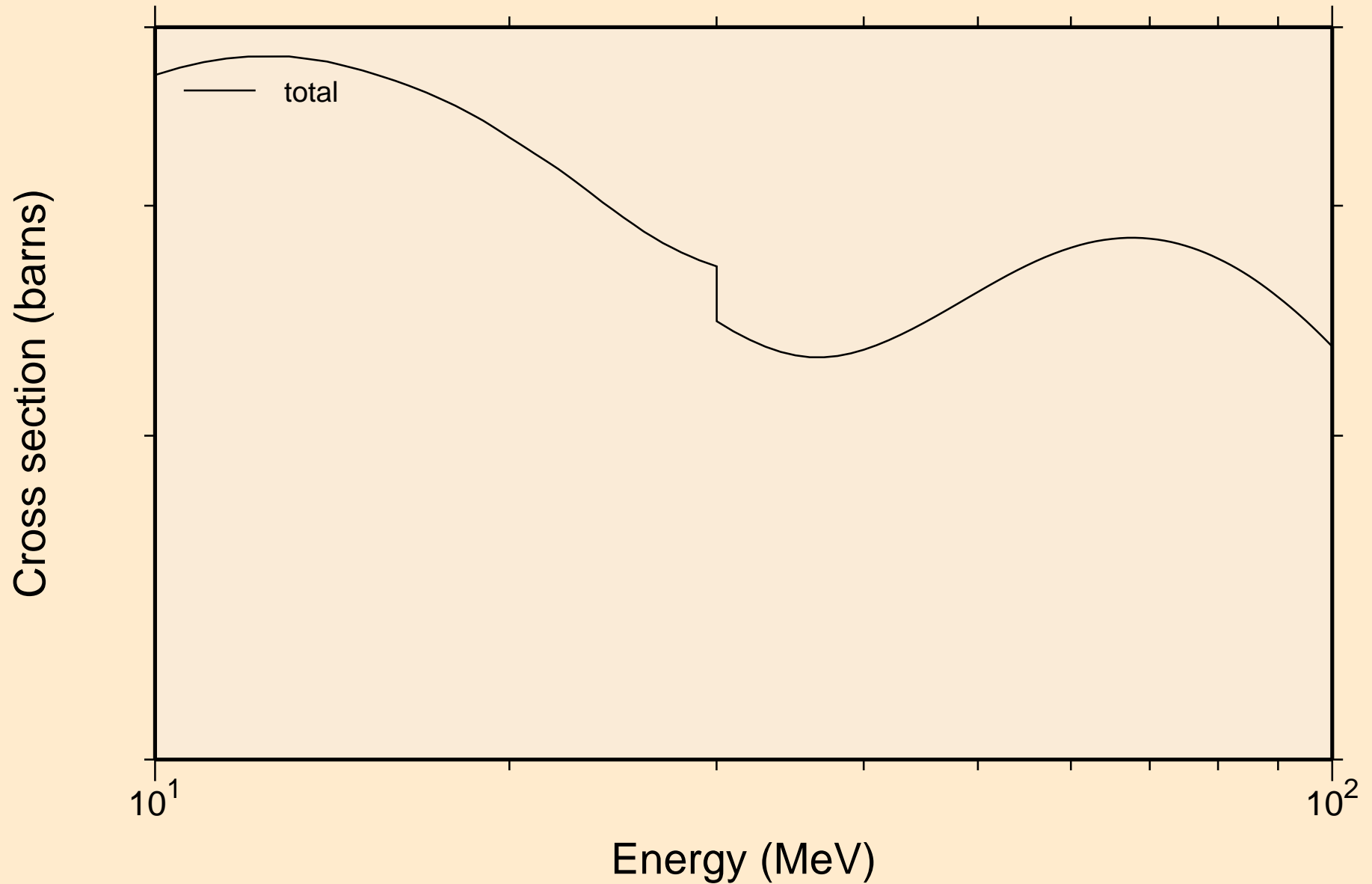

53-I-127 FOR FENDL-3.1 FROM FENDL-3.1 WITH NJOY2012.50+ C  
resonance absorption cross sections

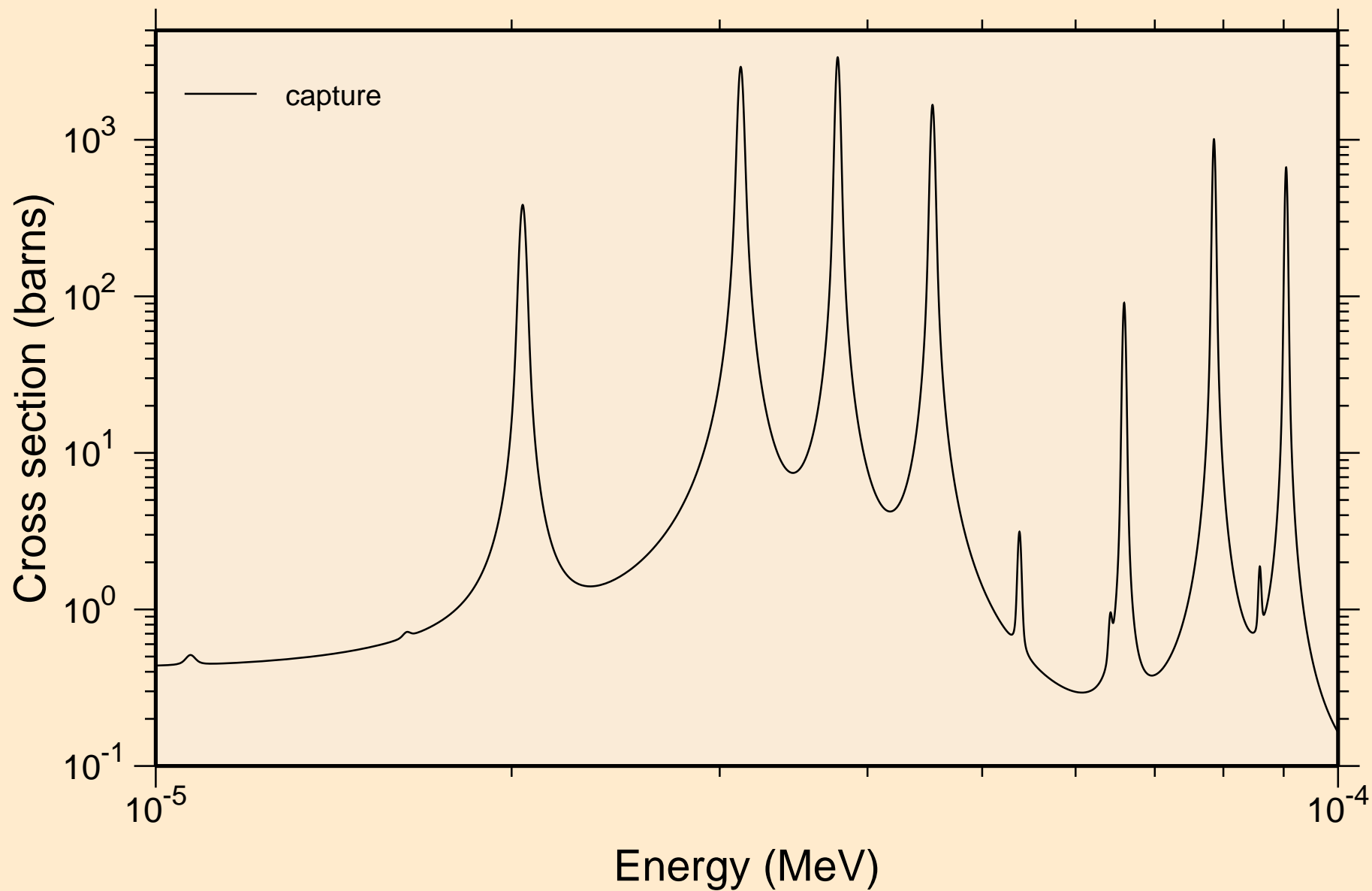

# 53-I-127 FOR FENDL-3.1 FROM FENDL-3.1 WITH NJOY2012.50+ C resonance absorption cross sections

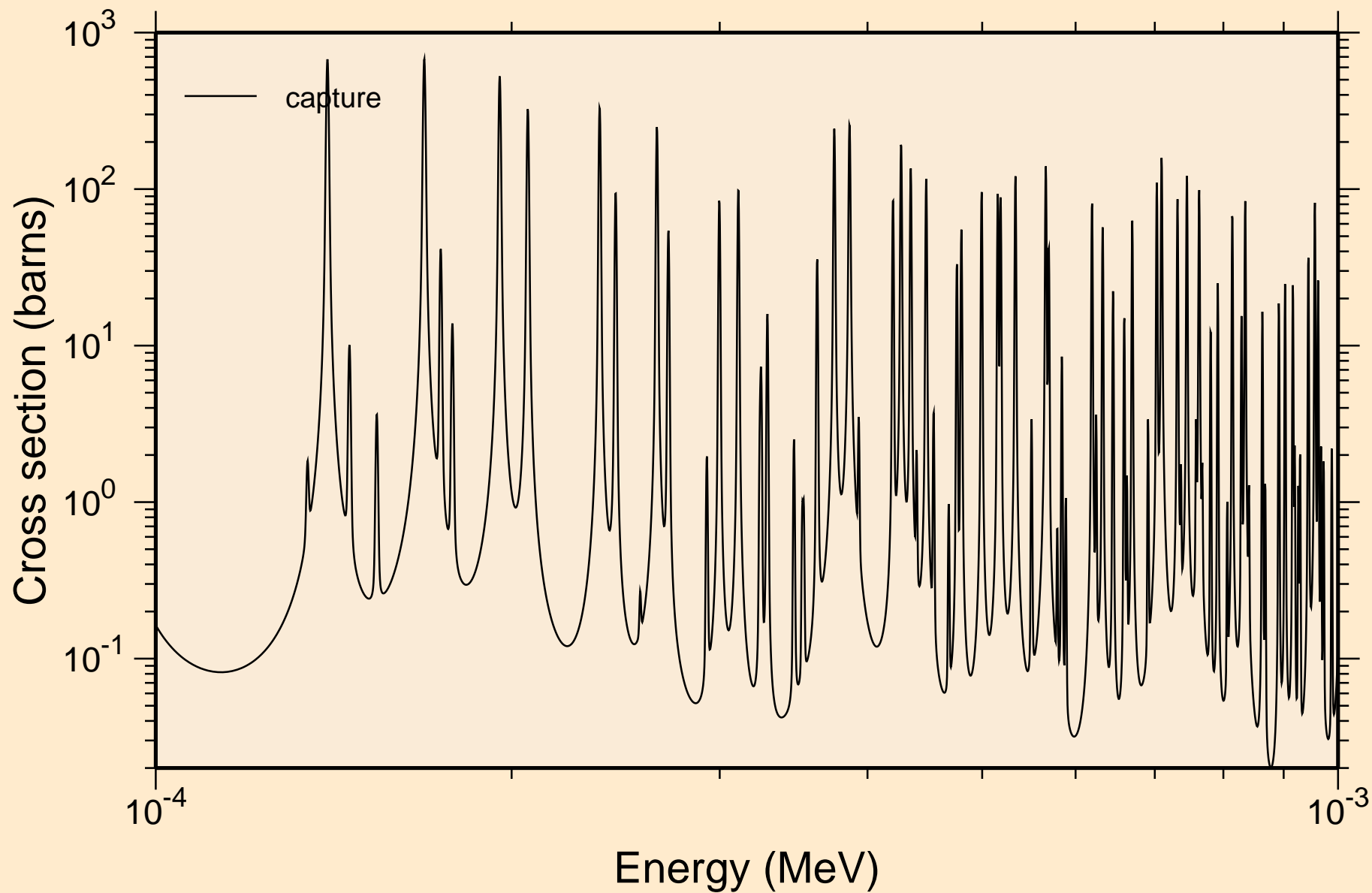

53-I-127 FOR FENDL-3.1 FROM FENDL-3.1 WITH NJOY2012.50+ C  
resonance absorption cross sections

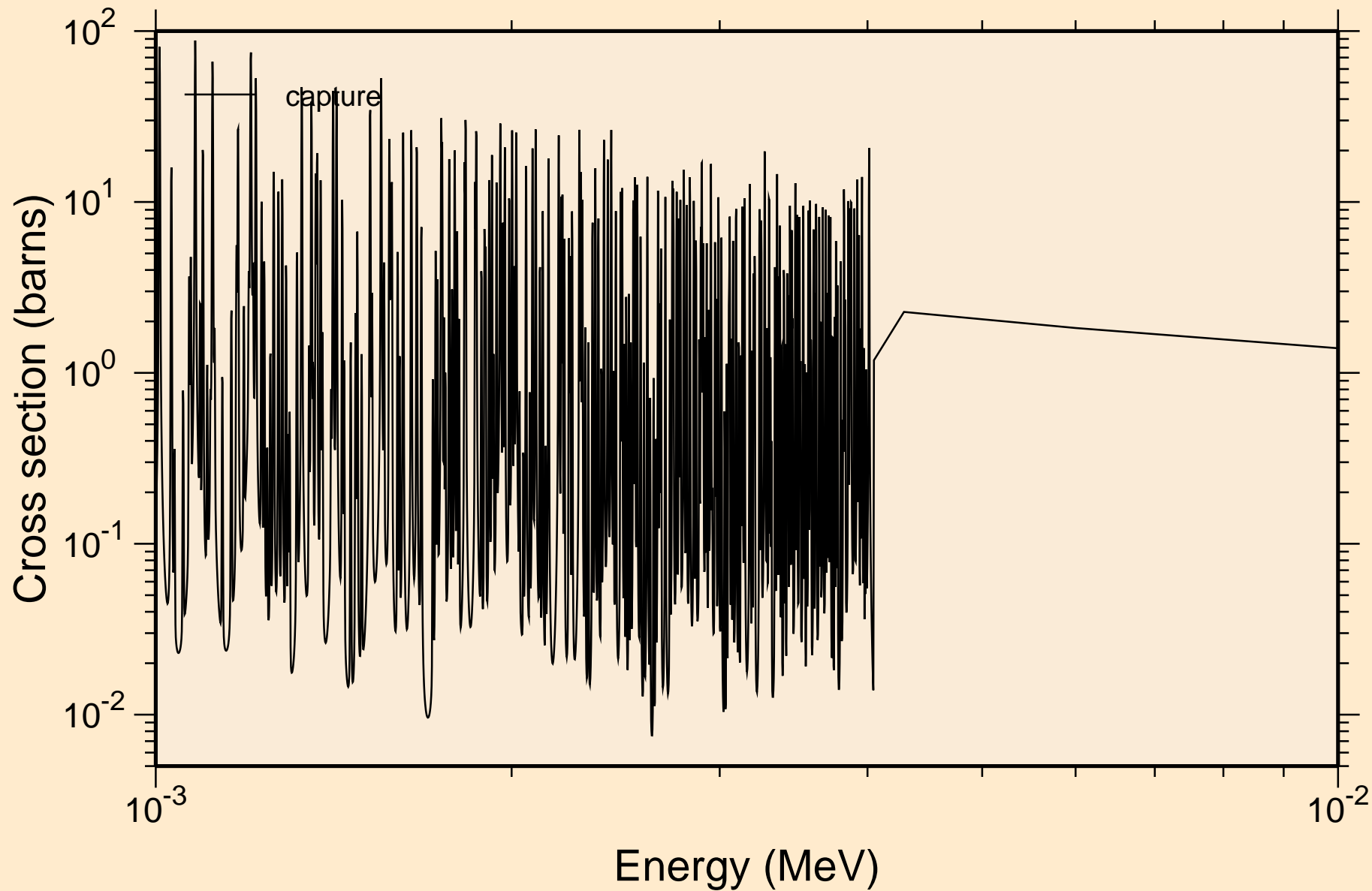



53-I-127 FOR FENDL-3.1 FROM FENDL-3.1 WITH NJOY2012.50+ C  
resonance absorption cross sections

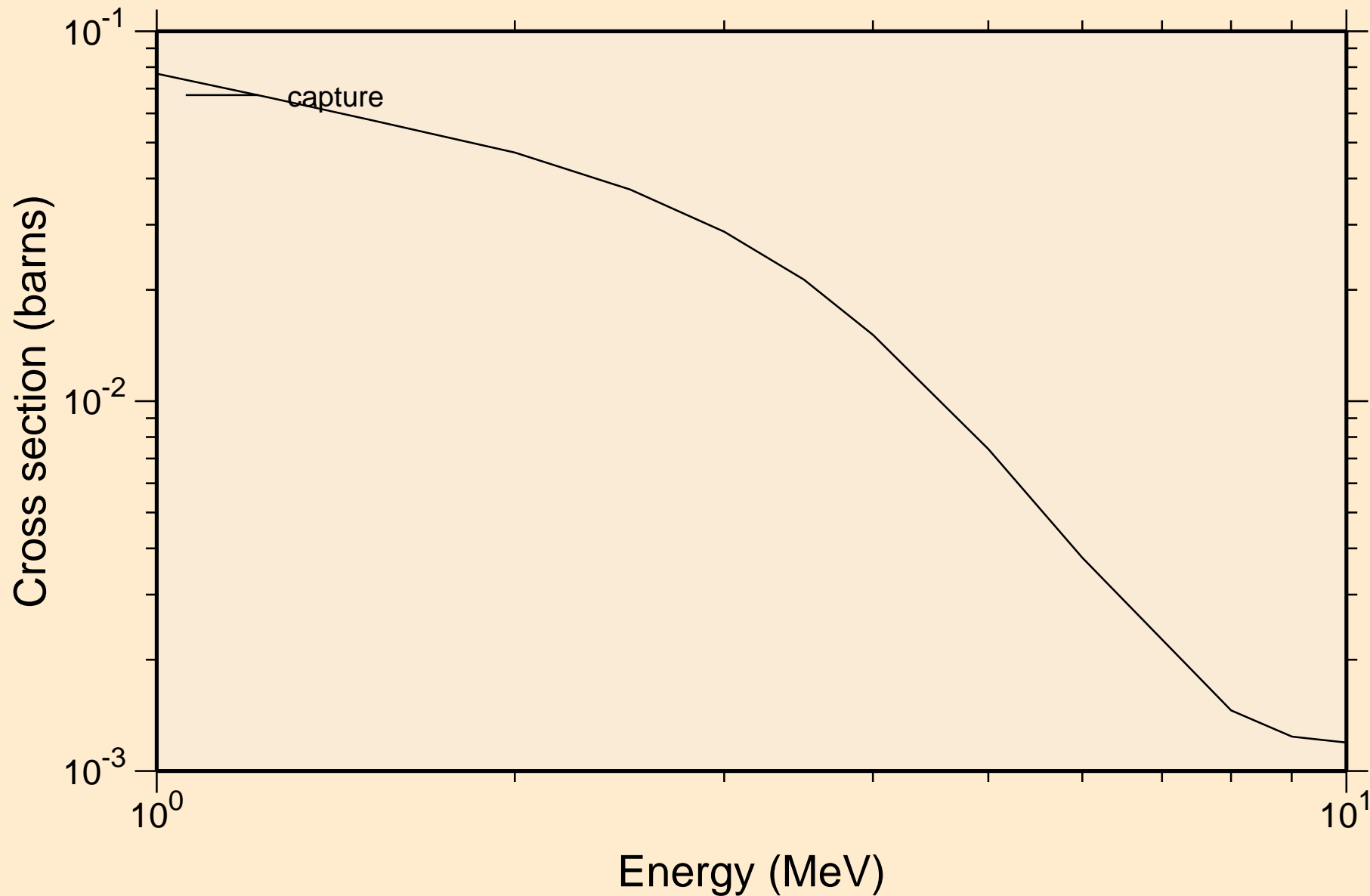

# 53-I-127 FOR FENDL-3.1 FROM FENDL-3.1 WITH NJOY2012.50+ C Heating

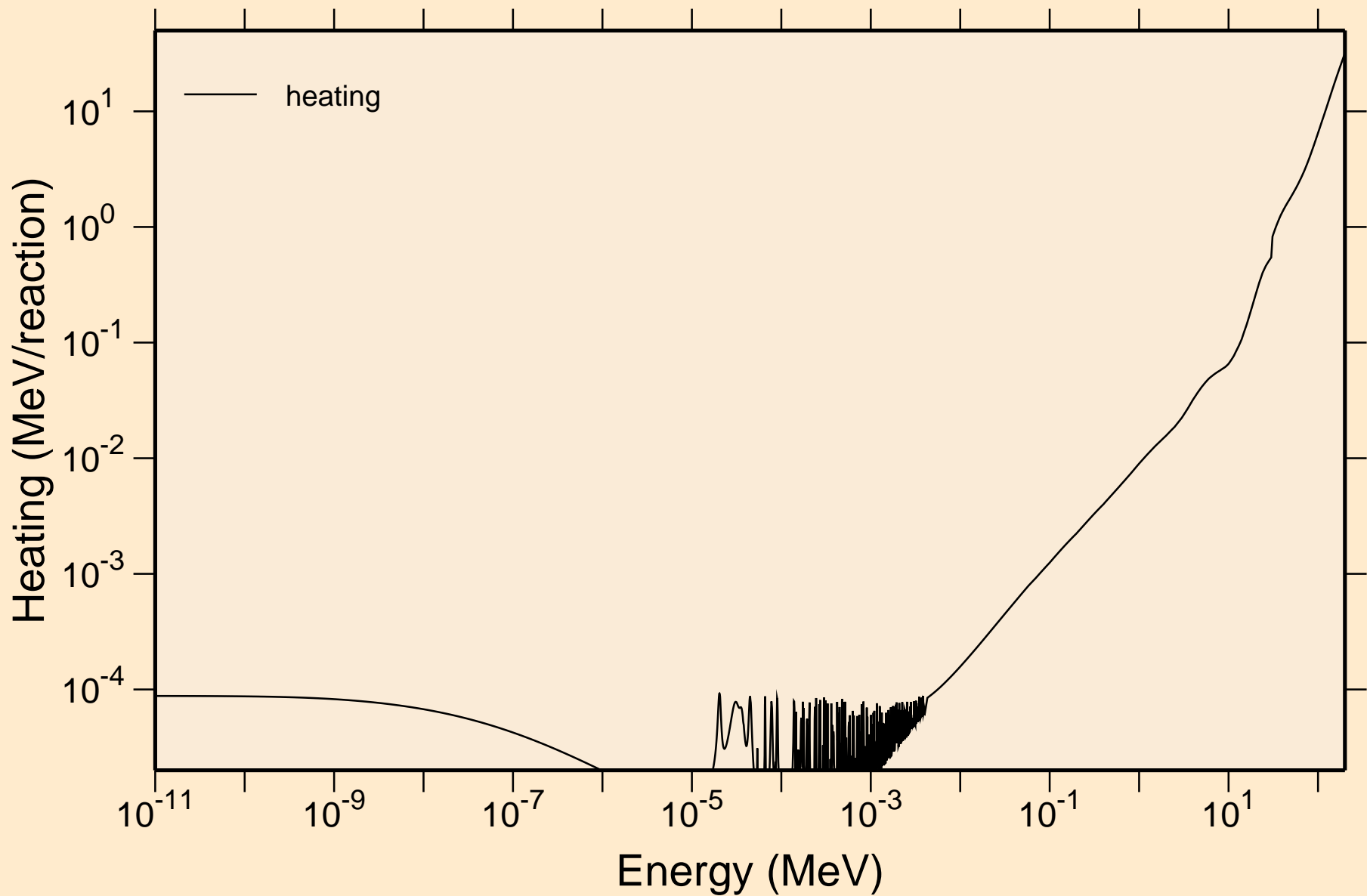

# 53-I-127 FOR FENDL-3.1 FROM FENDL-3.1 WITH NJOY2012.50+ C Damage

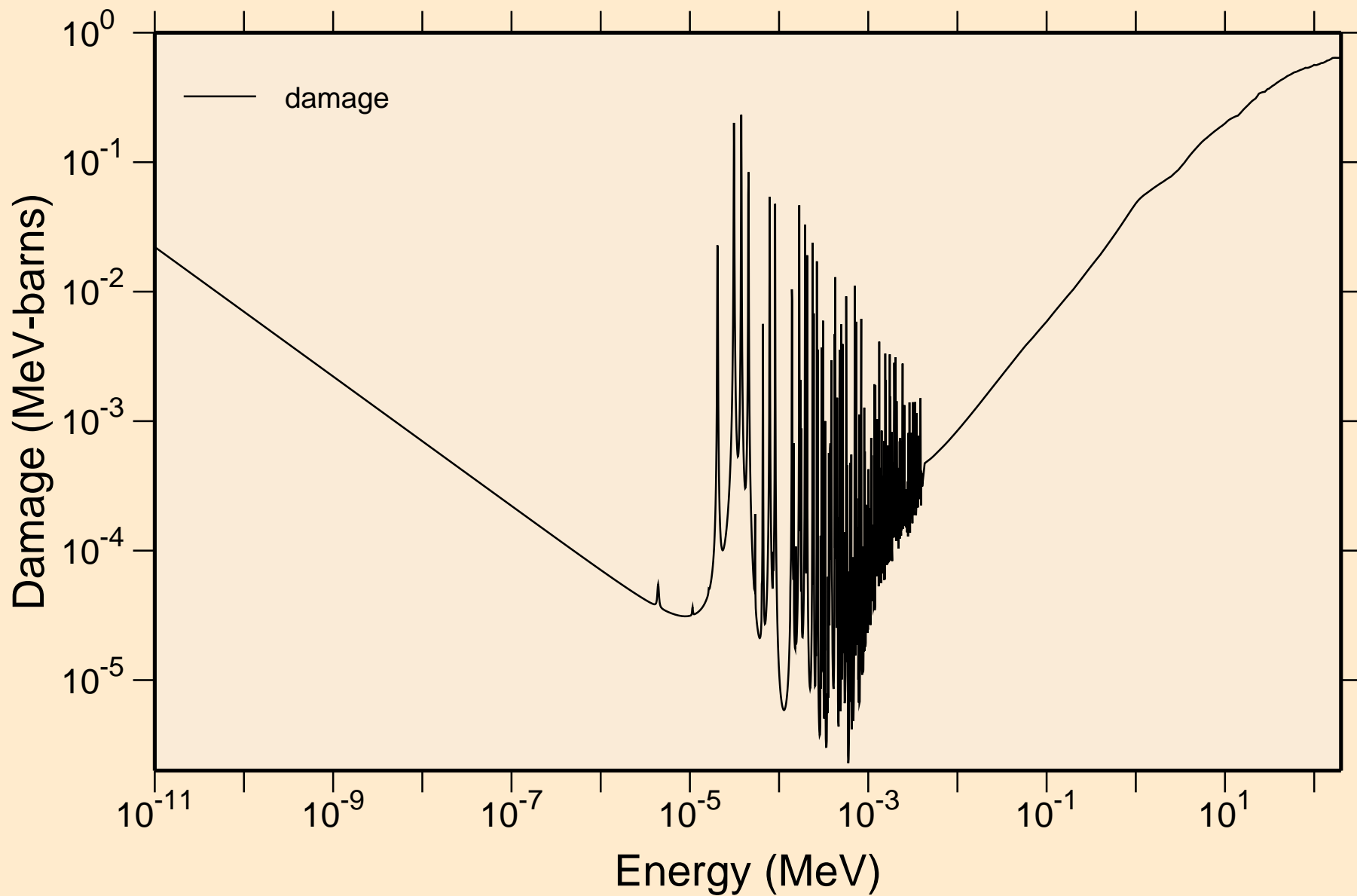

# 53-I-127 FOR FENDL-3.1 FROM FENDL-3.1 WITH NJOY2012.50+ C

## Non-threshold reactions

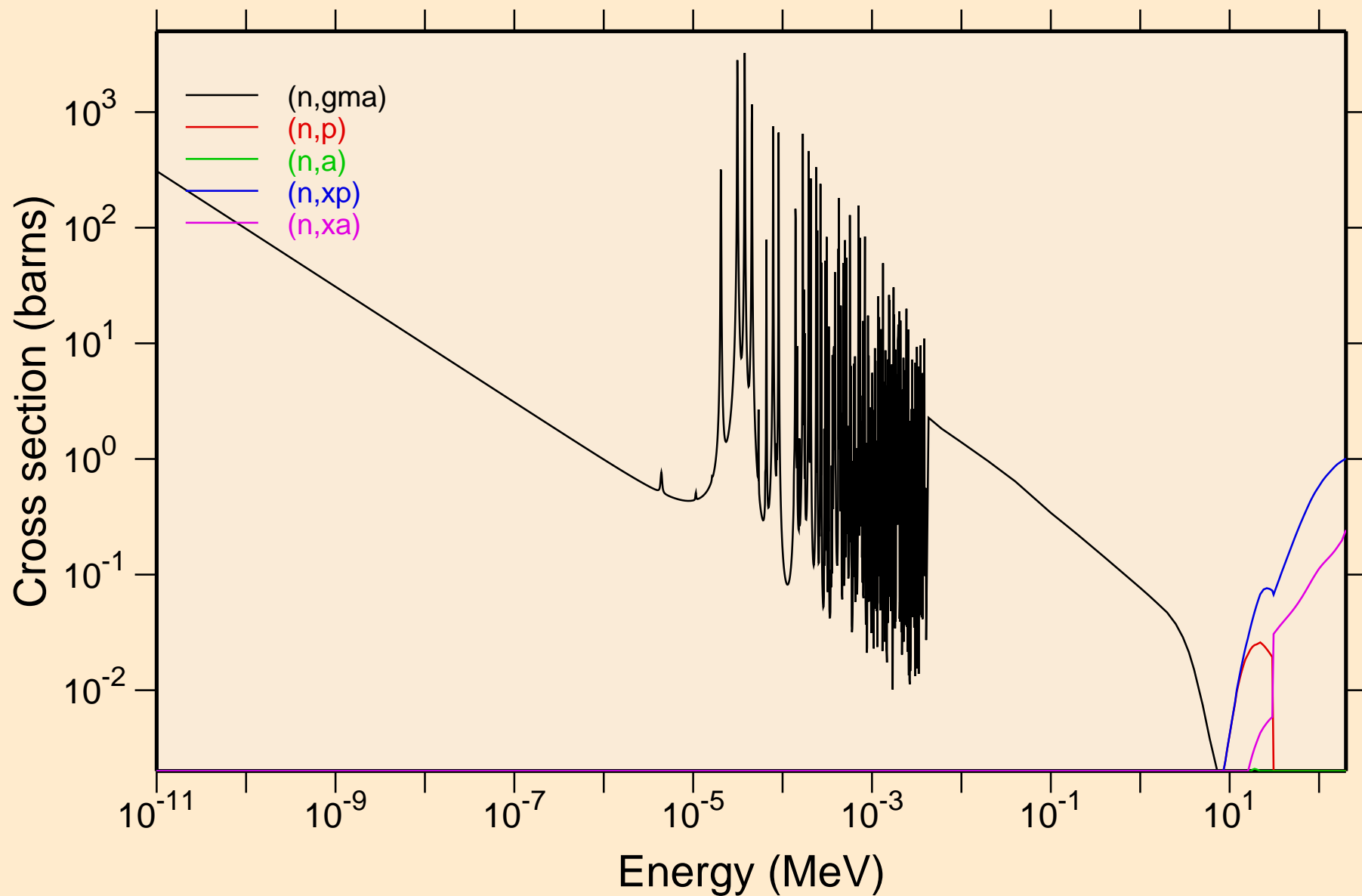

53-I-127 FOR FENDL-3.1 FROM FENDL-3.1 WITH NJOY2012.50+ C  
Principal cross sections

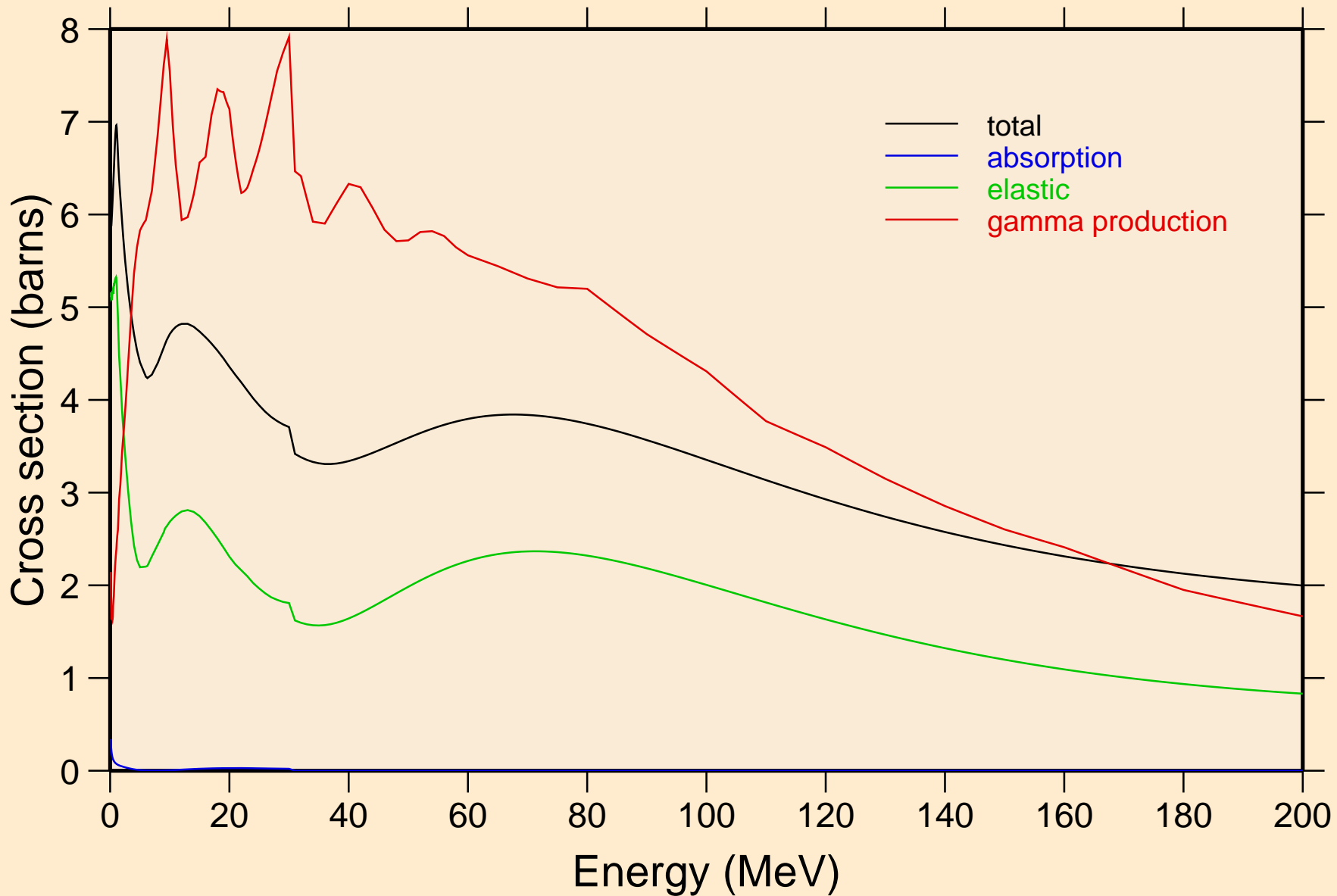

# 53-I-127 FOR FENDL-3.1 FROM FENDL-3.1 WITH NJOY2012.50+ C Heating

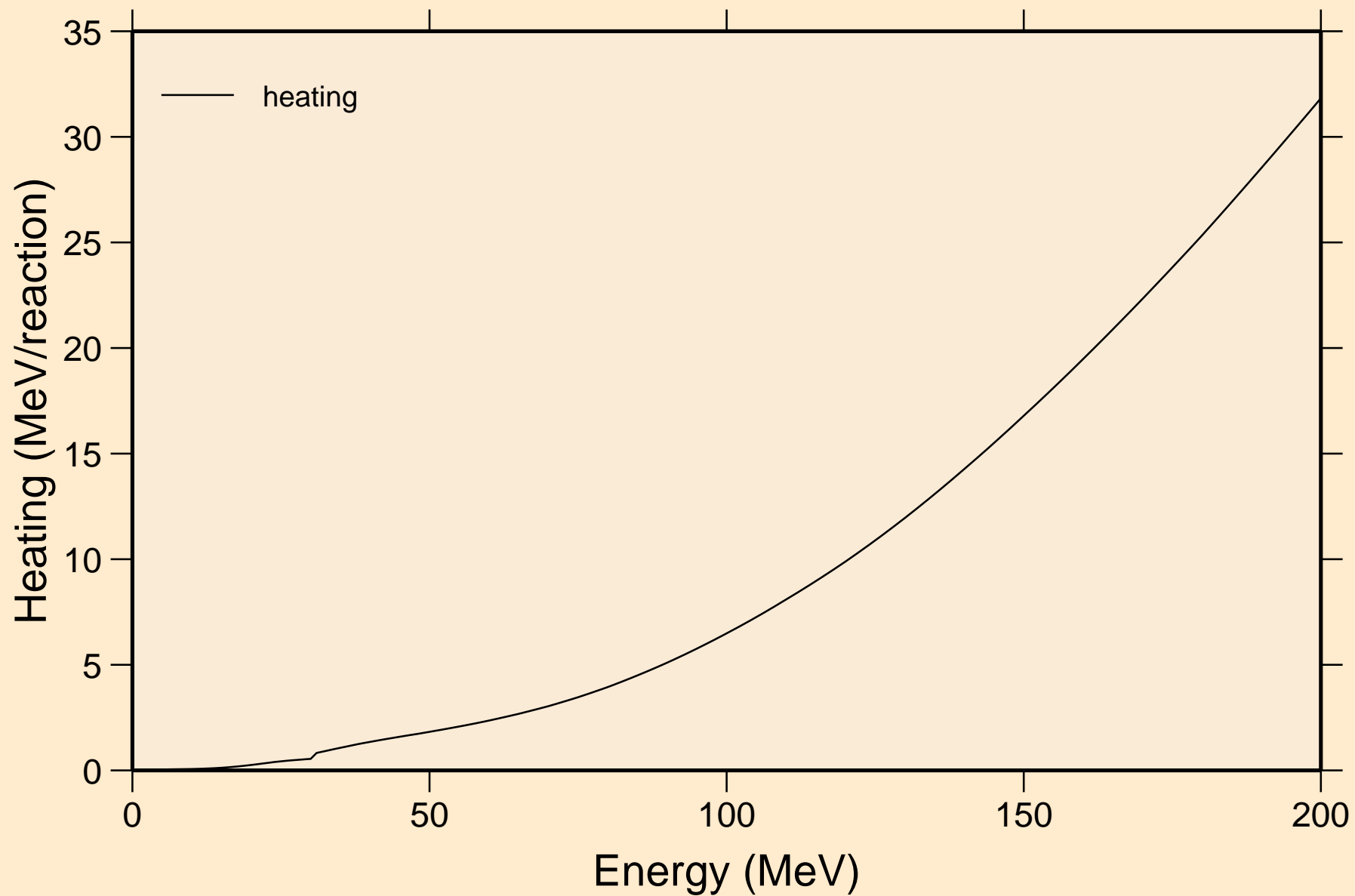

# 53-I-127 FOR FENDL-3.1 FROM FENDL-3.1 WITH NJOY2012.50+ C Damage

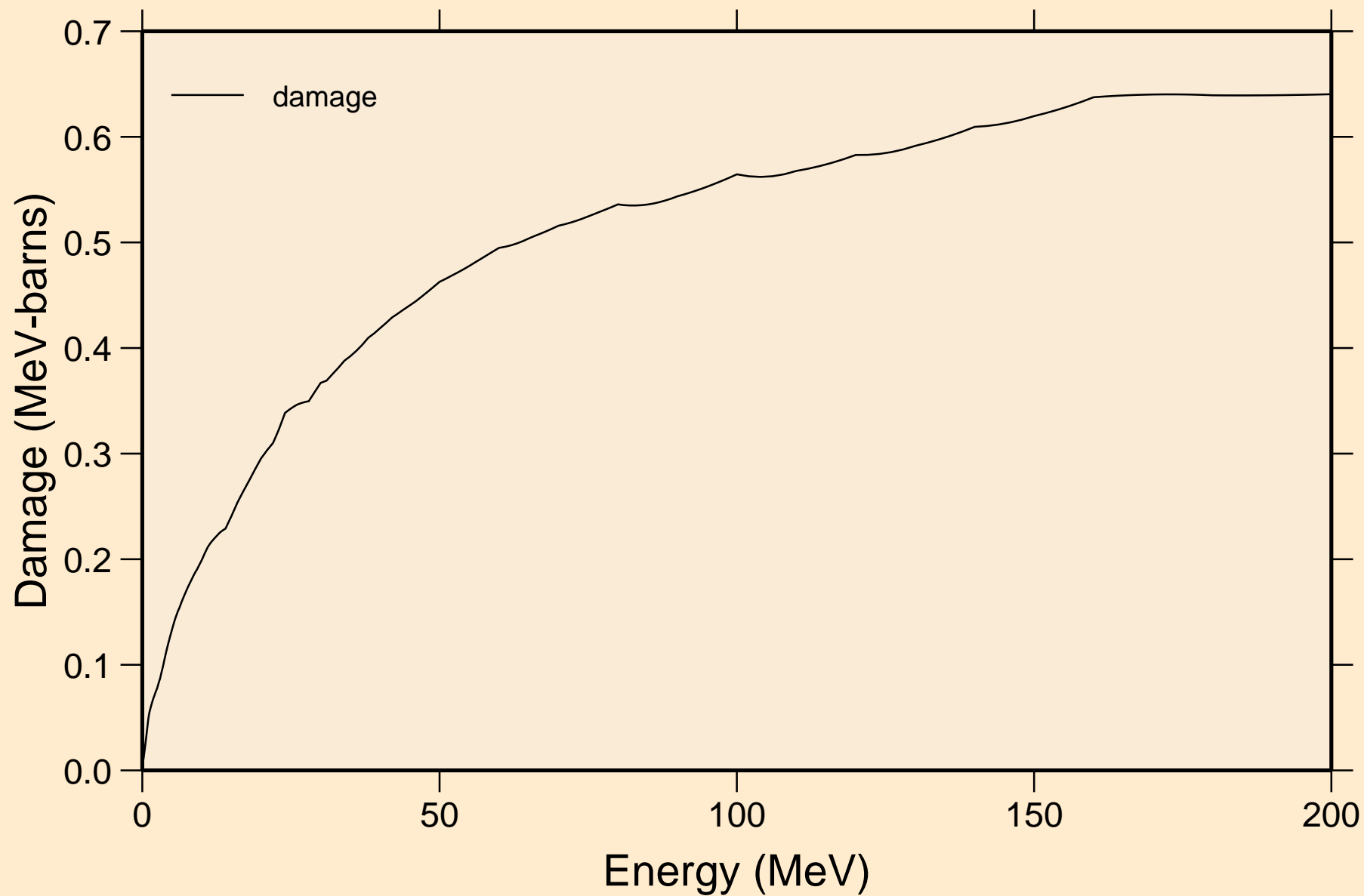

# 53-I-127 FOR FENDL-3.1 FROM FENDL-3.1 WITH NJOY2012.50+ C

## Non-threshold reactions

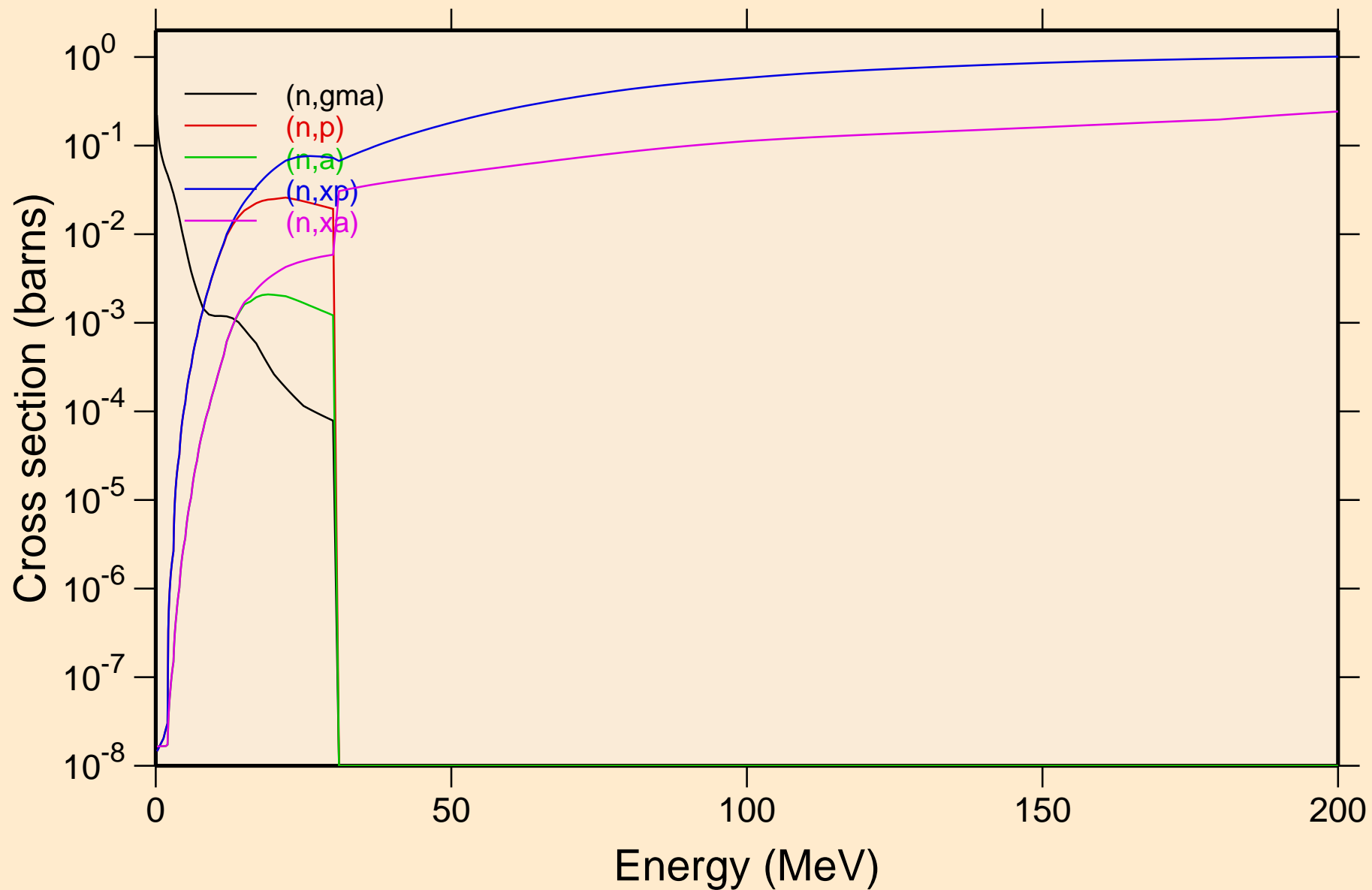



53-I-127 FOR FENDL-3.1 FROM FENDL-3.1 WITH NJOY2012.50+ C  
Inelastic levels

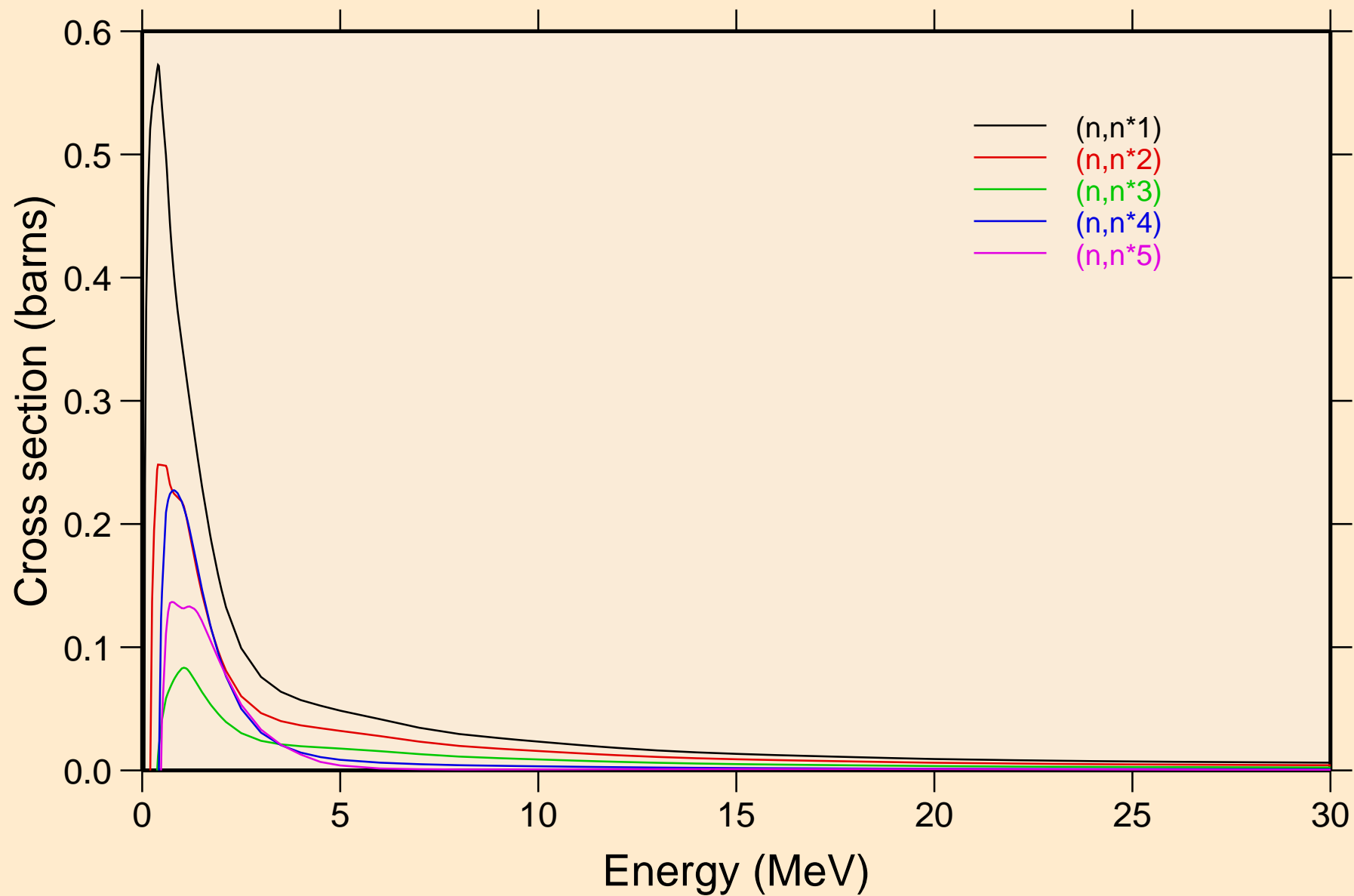

# 53-I-127 FOR FENDL-3.1 FROM FENDL-3.1 WITH NJOY2012.50+ C Inelastic levels

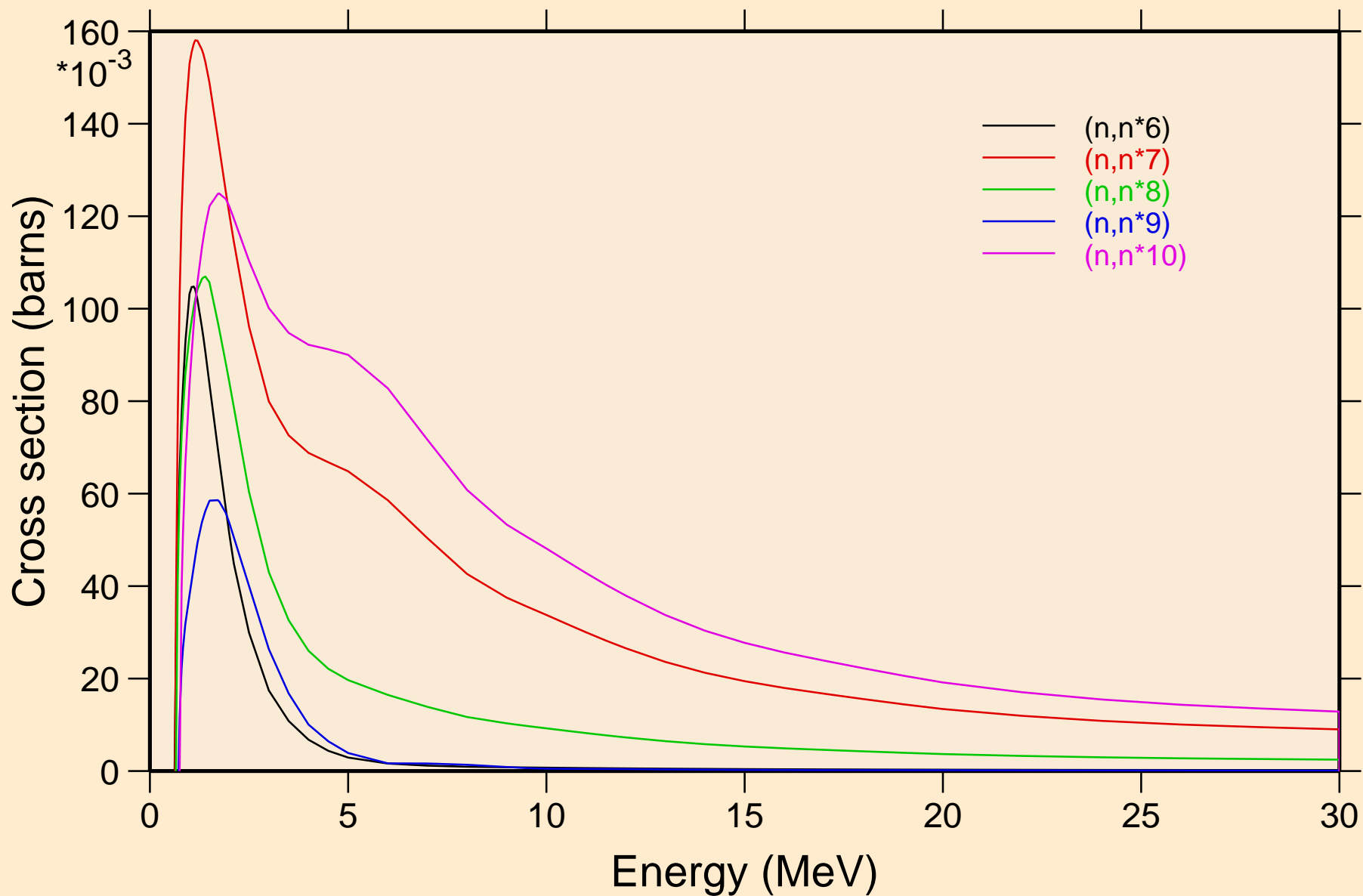

53-I-127 FOR FENDL-3.1 FROM FENDL-3.1 WITH NJOY2012.50+ C  
Inelastic levels

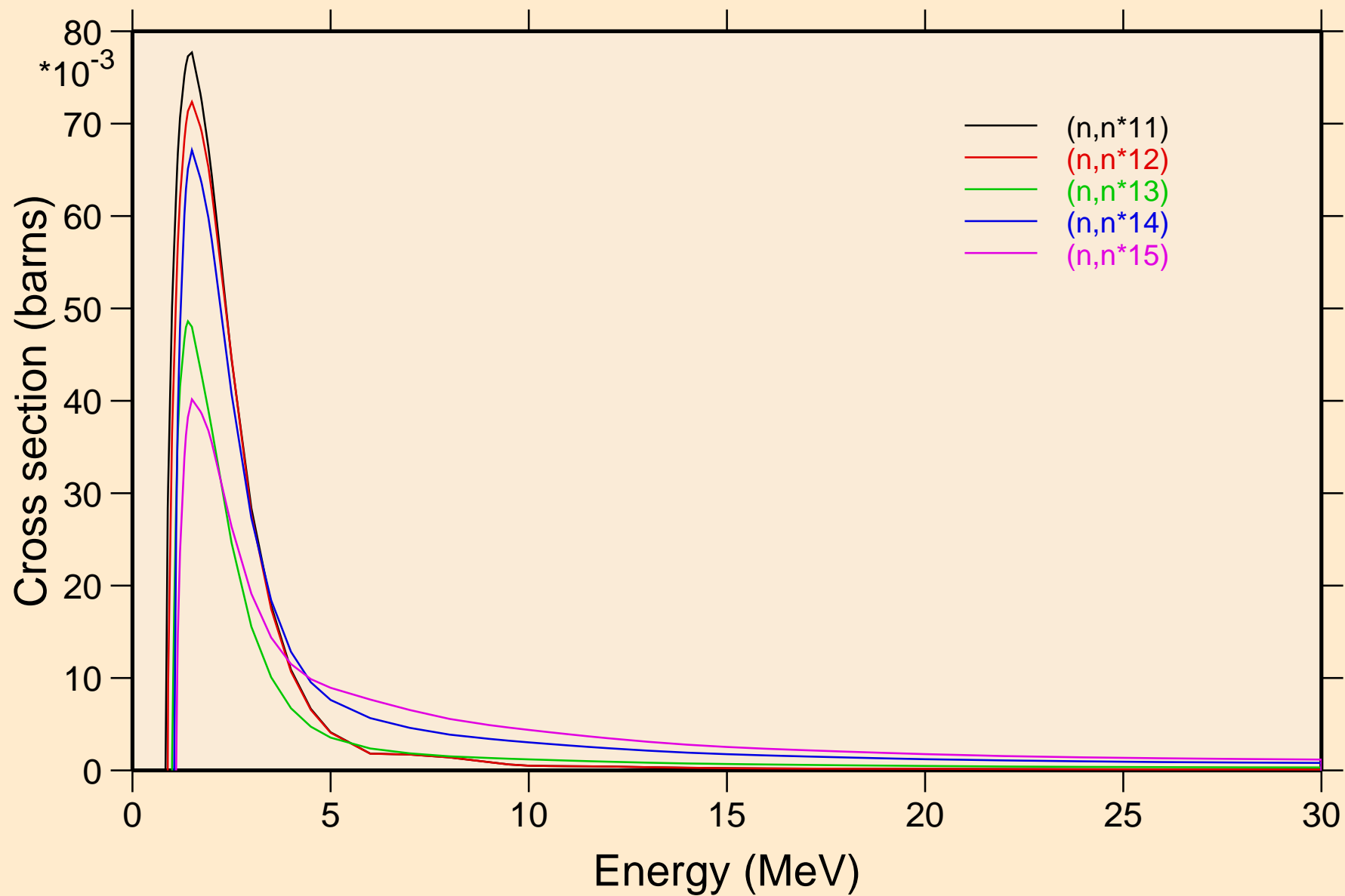

53-I-127 FOR FENDL-3.1 FROM FENDL-3.1 WITH NJOY2012.50+ C  
Inelastic levels

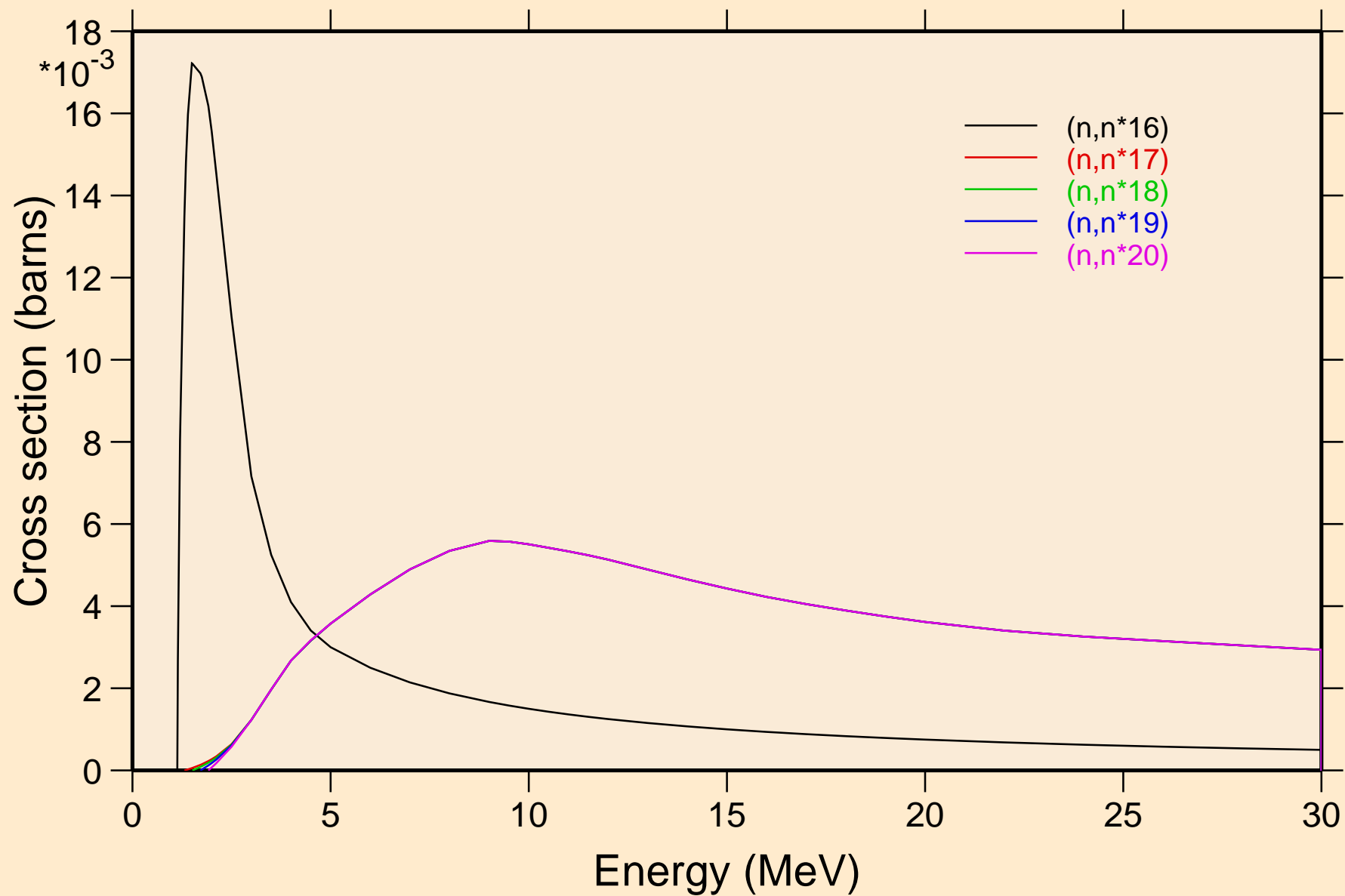

53-I-127 FOR FENDL-3.1 FROM FENDL-3.1 WITH NJOY2012.50+ C  
Inelastic levels

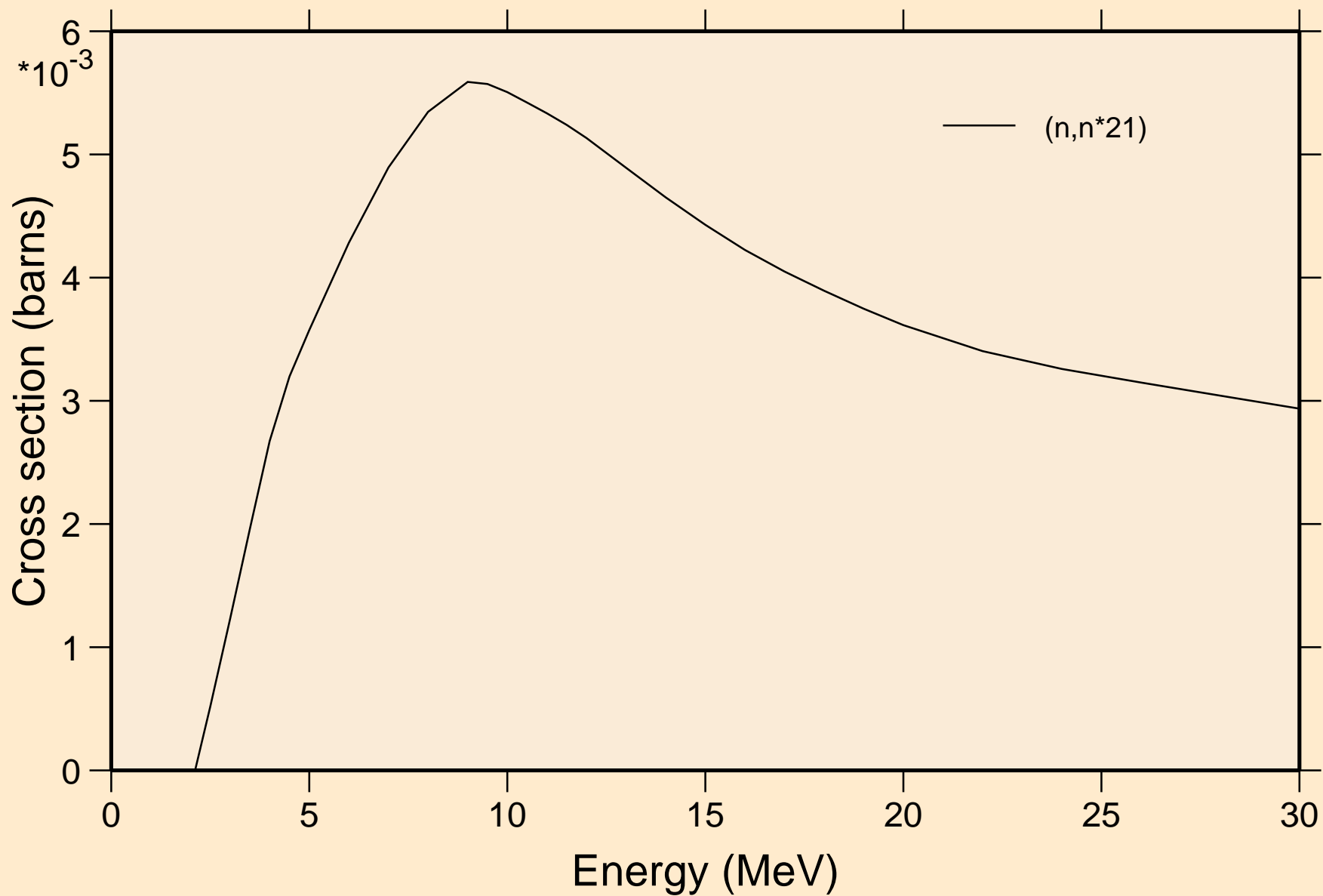

# 53-I-127 FOR FENDL-3.1 FROM FENDL-3.1 WITH NJOY2012.50+ C

## Threshold reactions

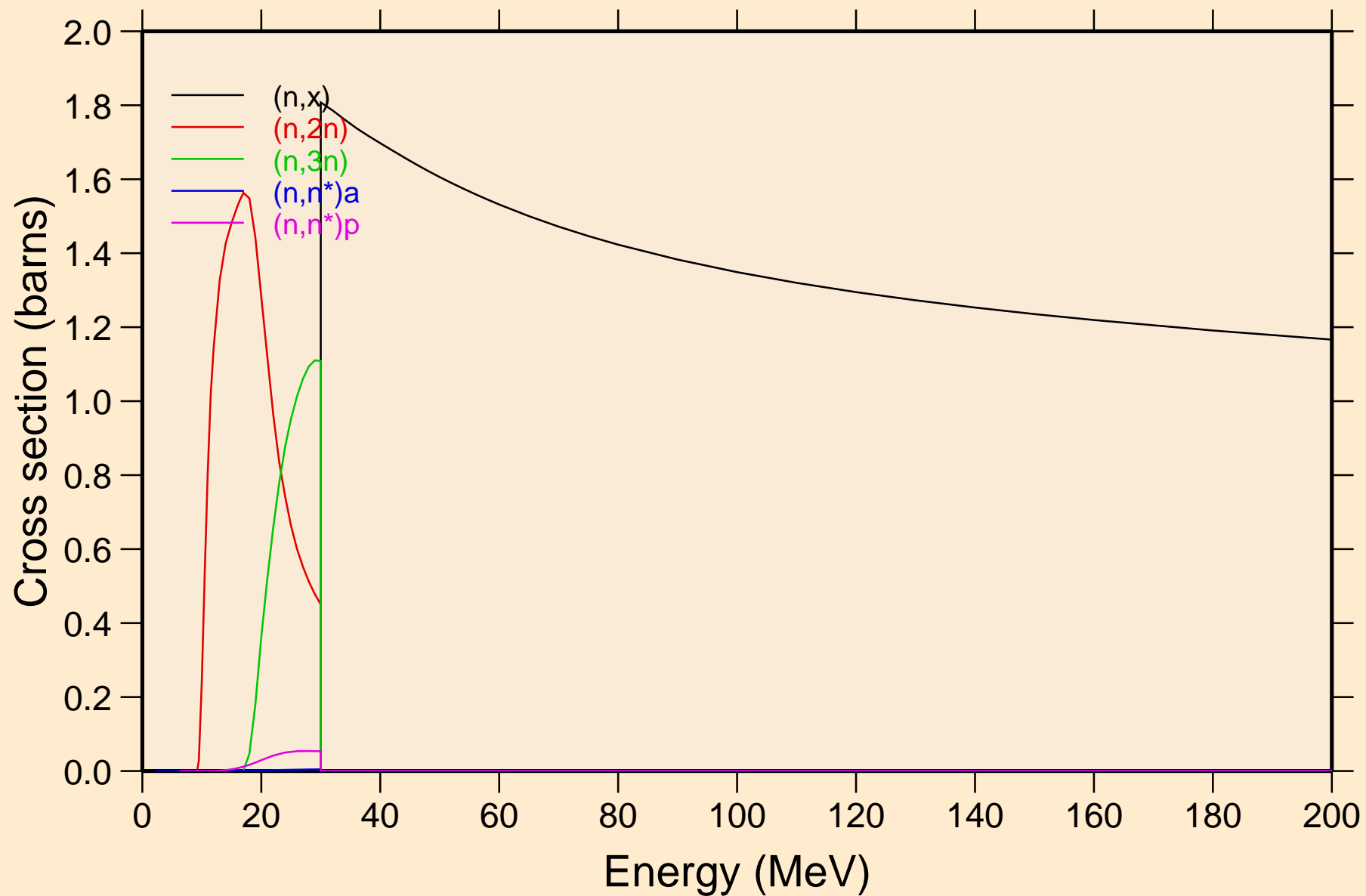

# 53-I-127 FOR FENDL-3.1 FROM FENDL-3.1 WITH NJOY2012.50+ C

## Threshold reactions

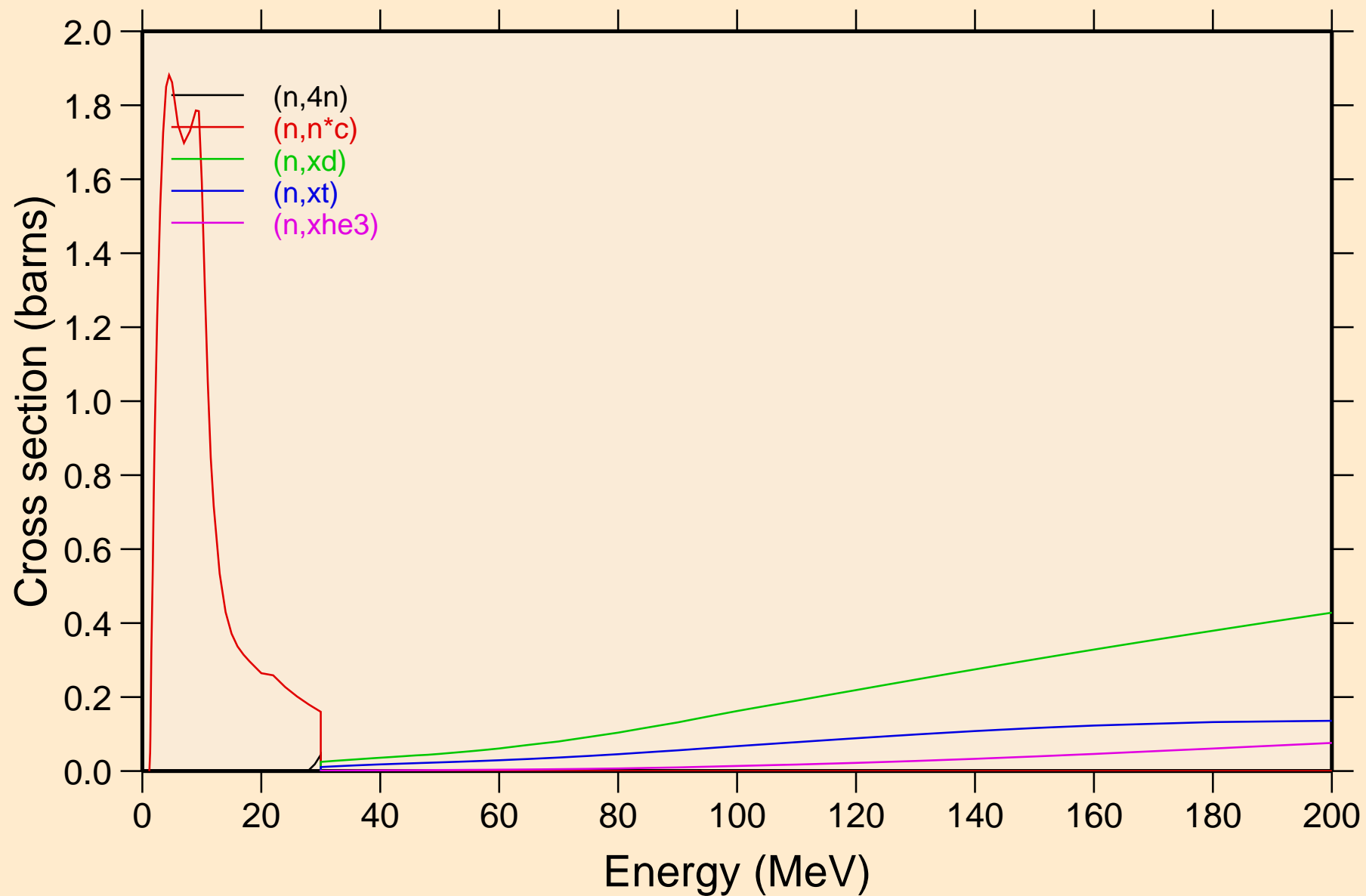

53-I-127 FOR FENDL-3.1 FROM FENDL-3.1 WITH NJOY2012.50+ C  
Threshold reactions

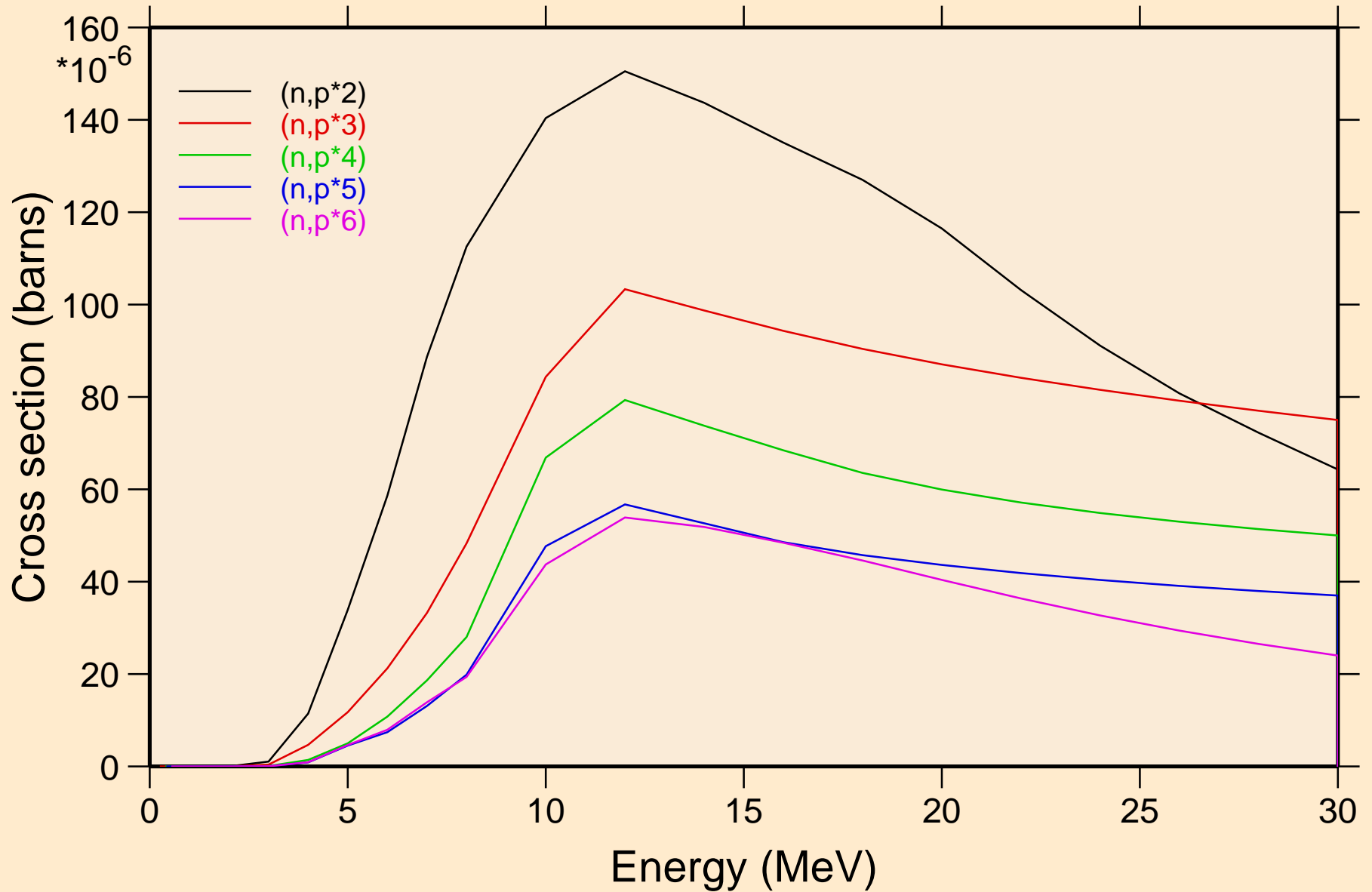



53-I-127 FOR FENDL-3.1 FROM FENDL-3.1 WITH NJOY2012.50+ C  
Threshold reactions

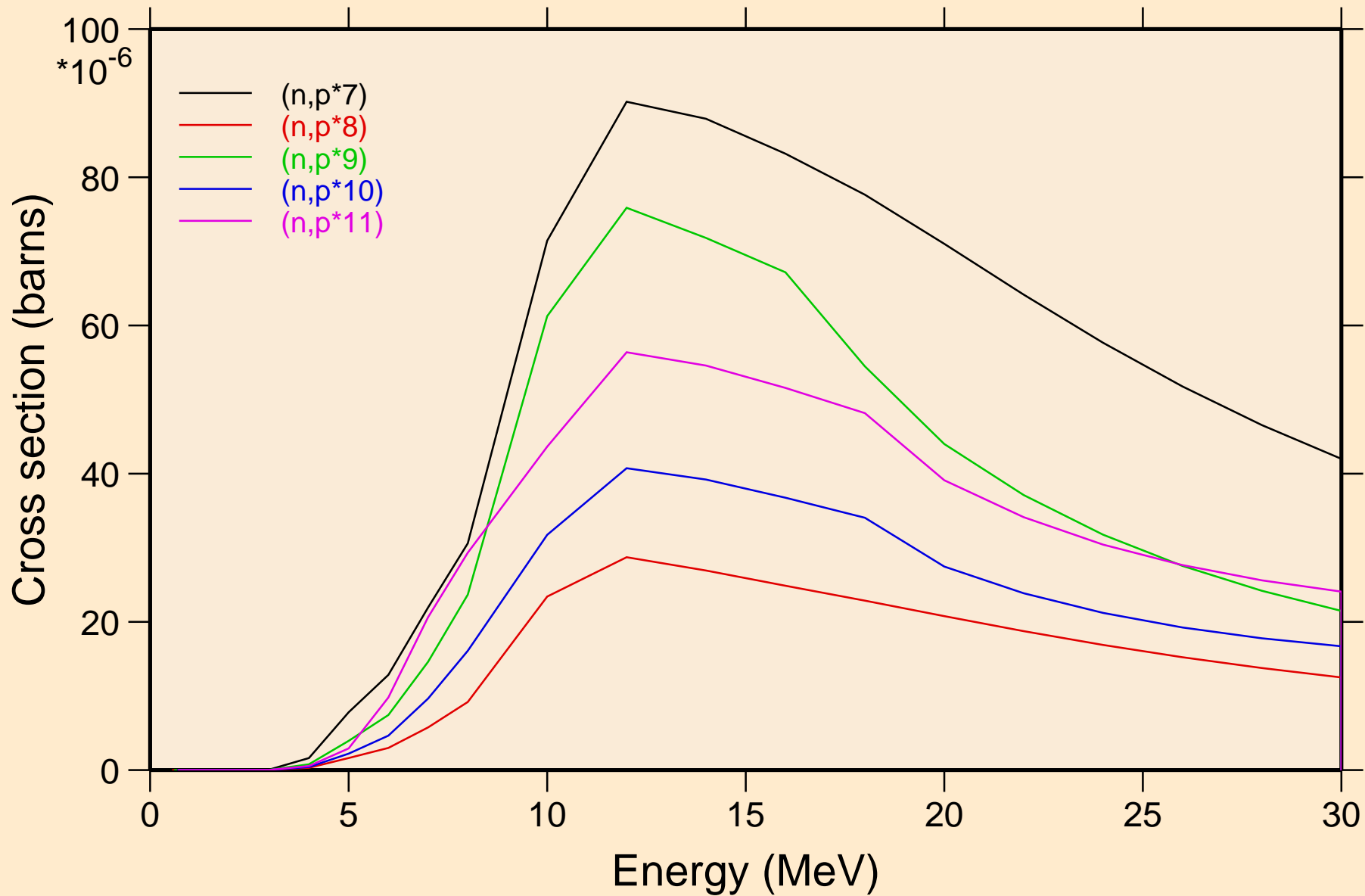

# 53-I-127 FOR FENDL-3.1 FROM FENDL-3.1 WITH NJOY2012.50+ C

## Threshold reactions

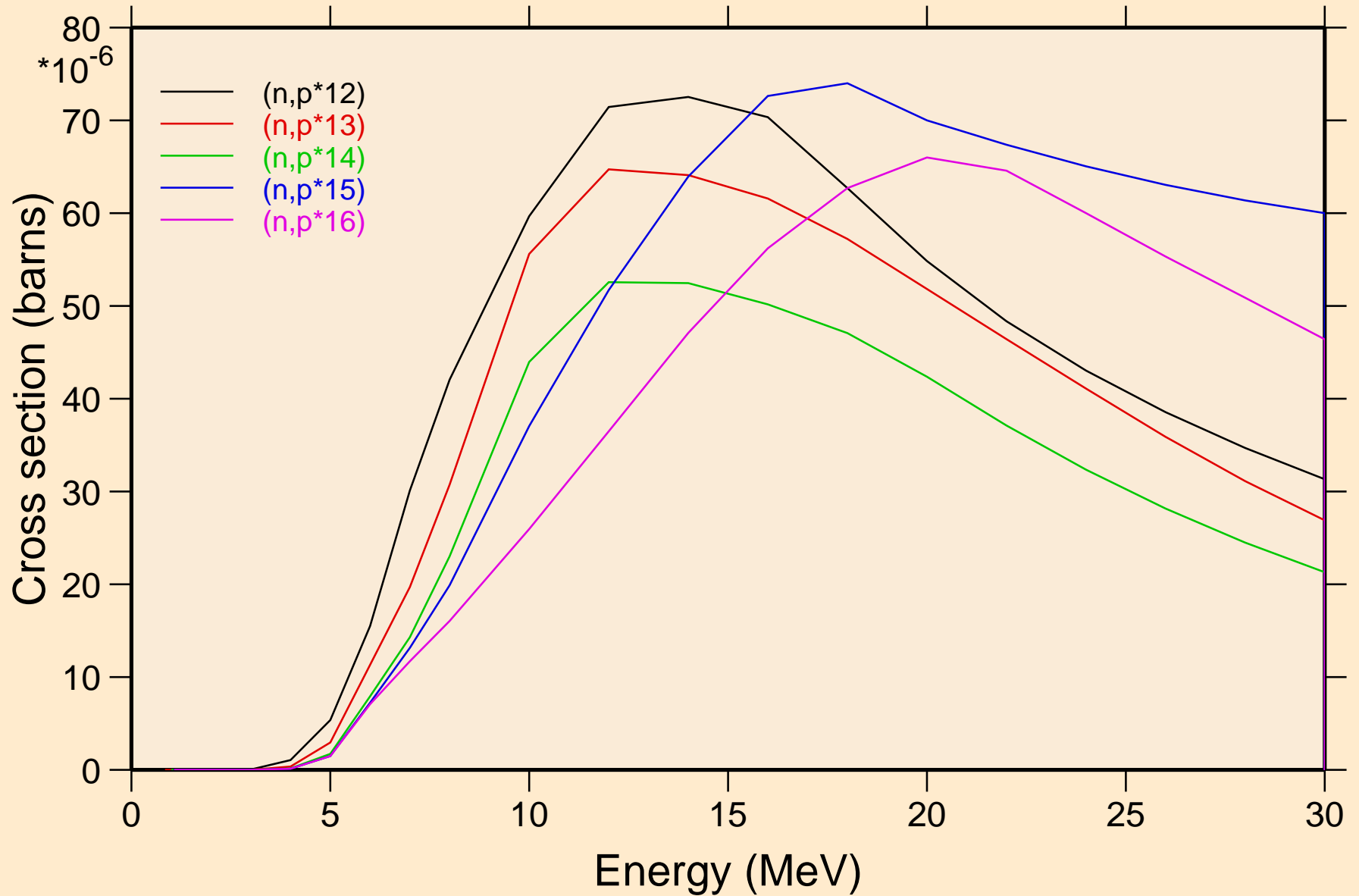

# 53-I-127 FOR FENDL-3.1 FROM FENDL-3.1 WITH NJOY2012.50+ C

## Threshold reactions

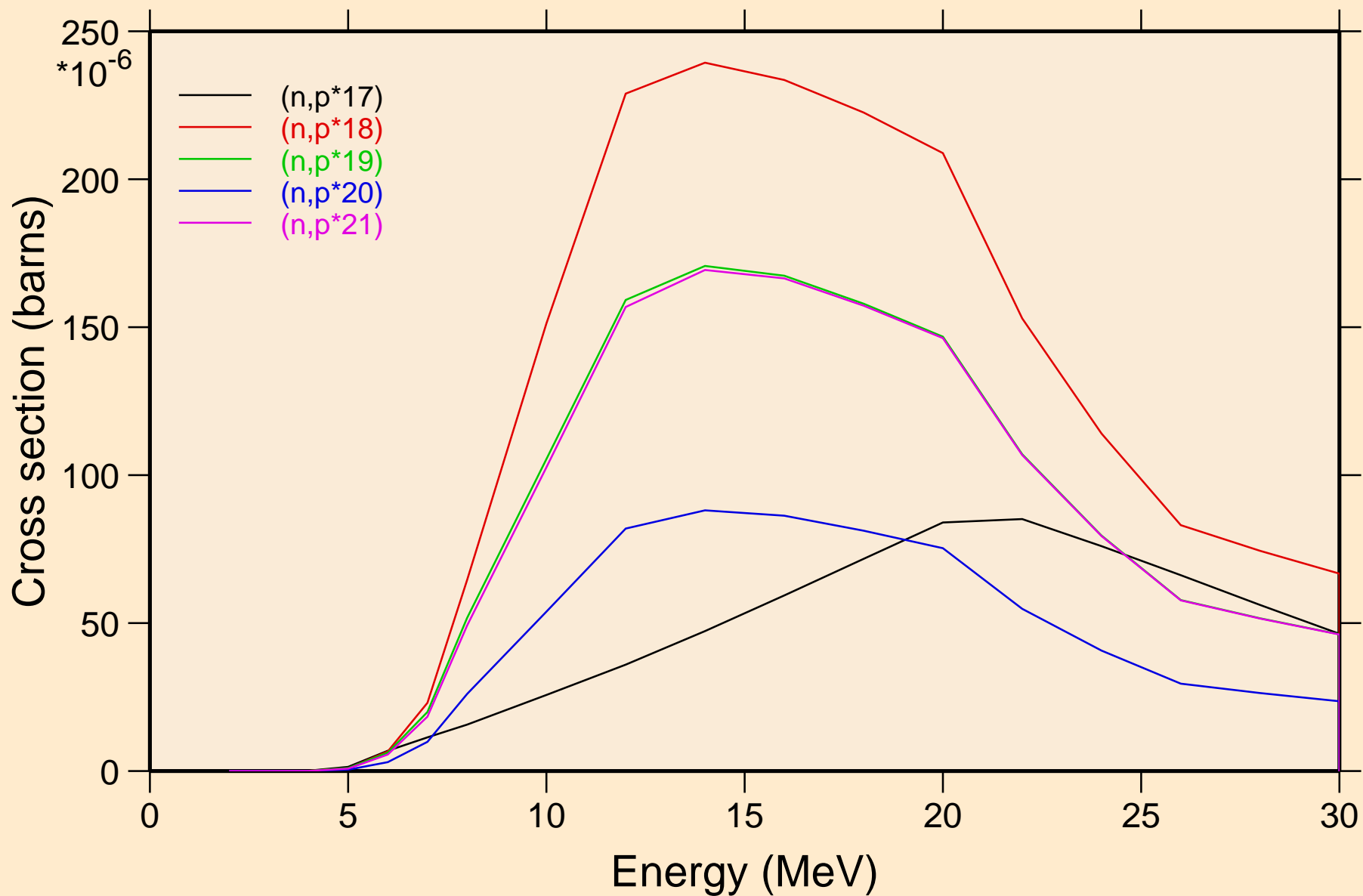

53-I-127 FOR FENDL-3.1 FROM FENDL-3.1 WITH NJOY2012.50+ C  
Threshold reactions

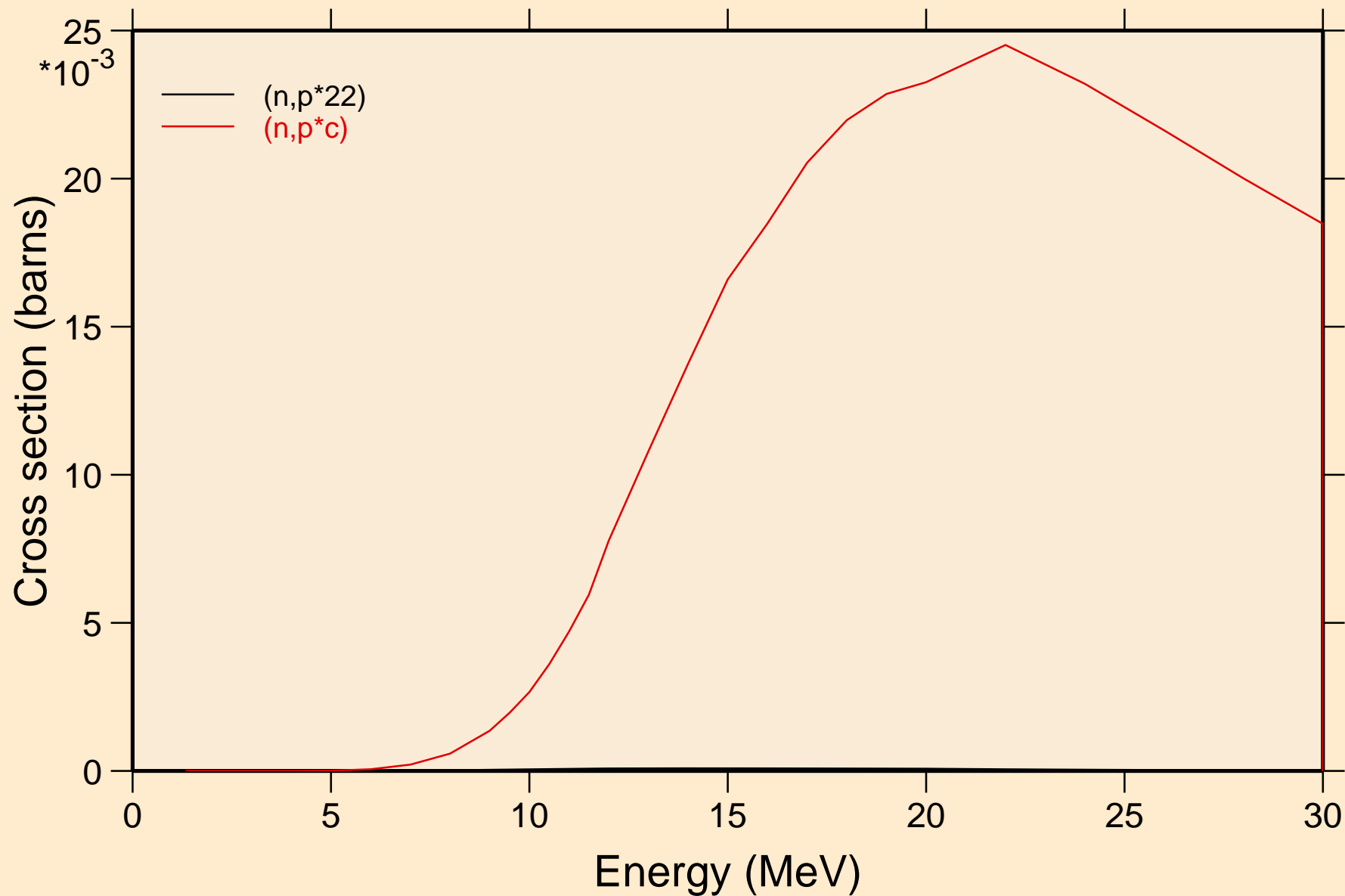

53-I-127 FOR FENDL-3.1 FROM FENDL-3.1 WITH NJOY2012.50+ C  
angular distribution for elastic

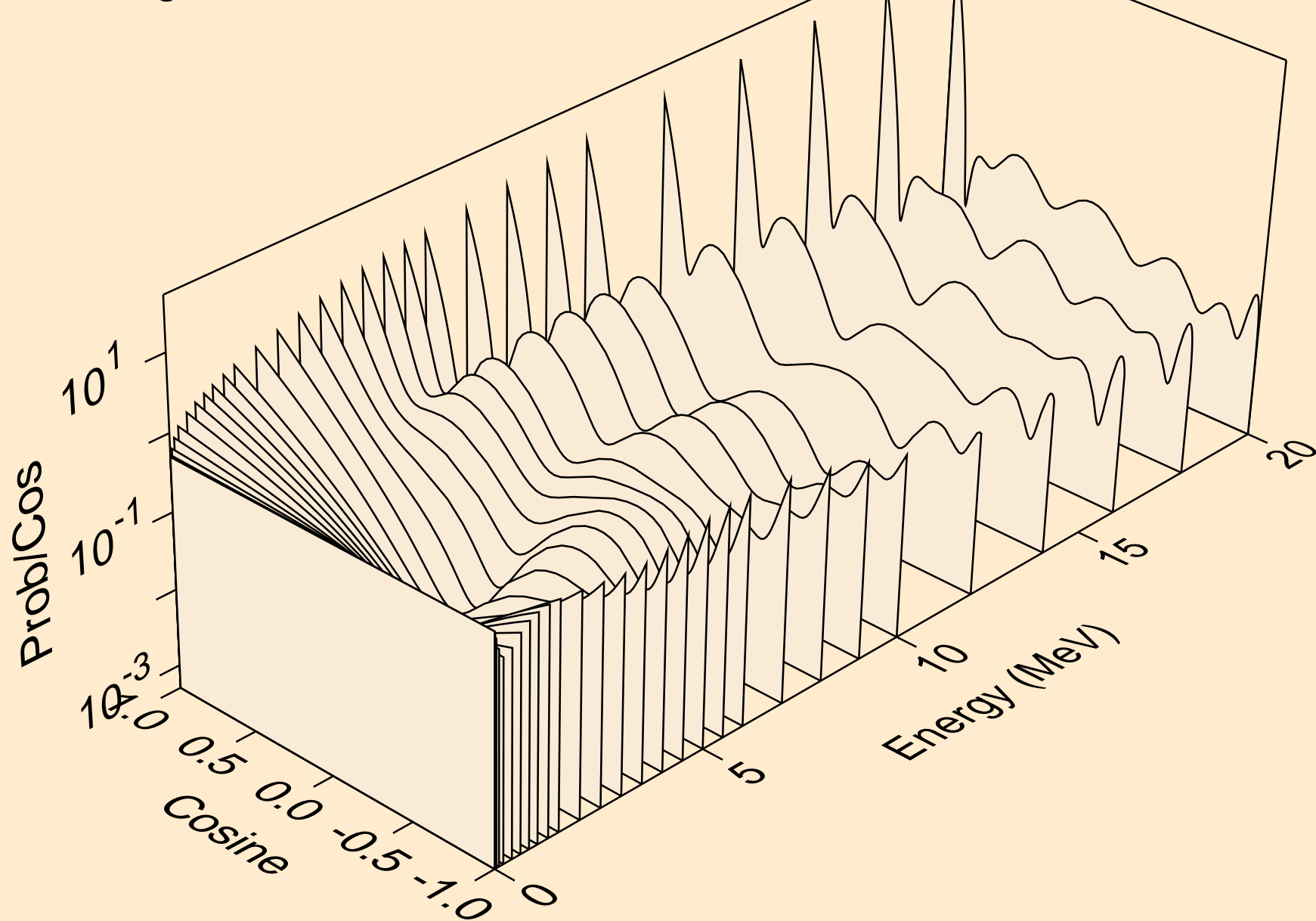

53-I-127 FOR FENDL-3.1 FROM FENDL-3.1 WITH NJOY2012.50+ C  
angular distribution for elastic

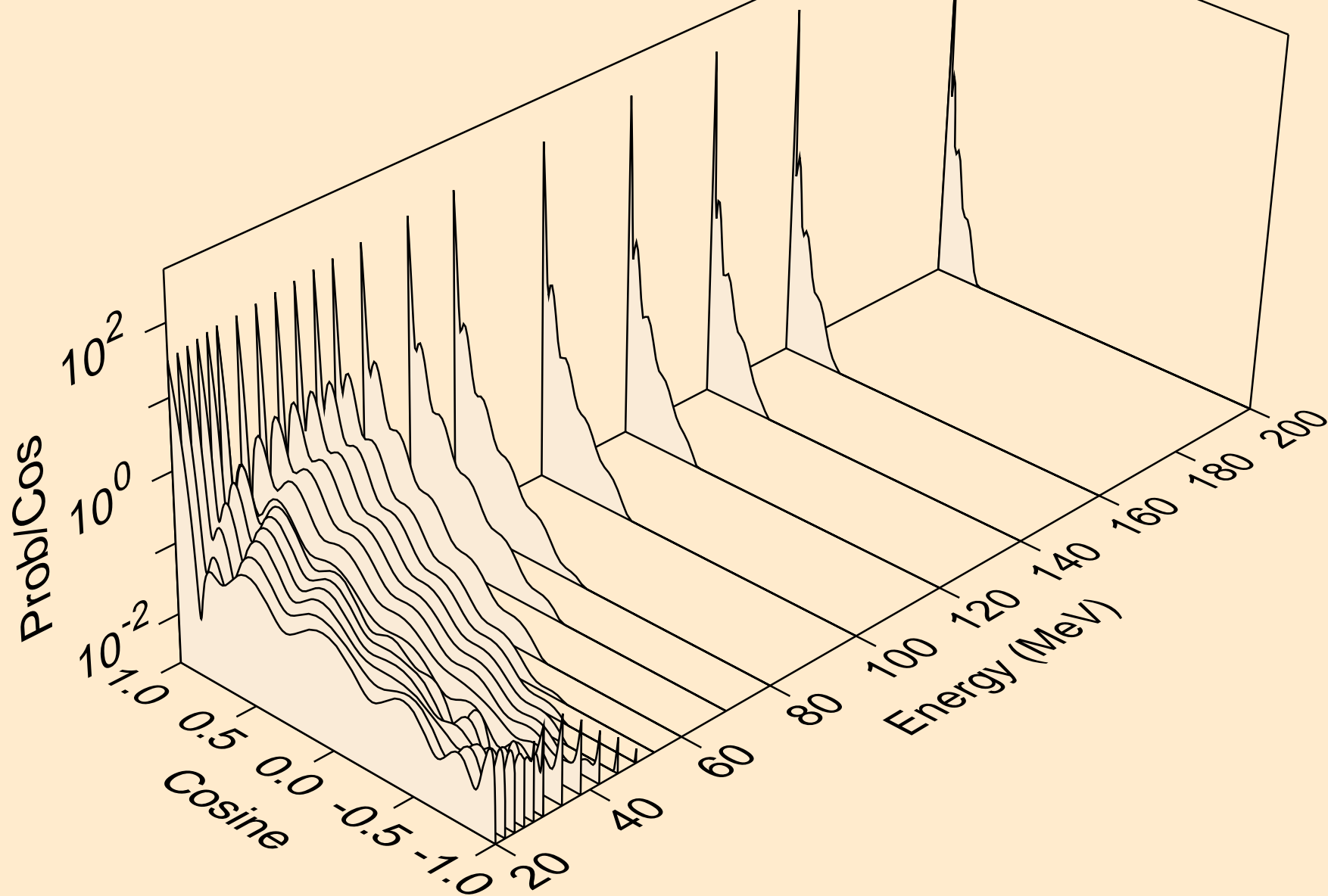

53-I-127 FOR FENDL-3.1 FROM FENDL-3.1 WITH NJOY2012.50+ C  
angular distribution for (n,n\*1)

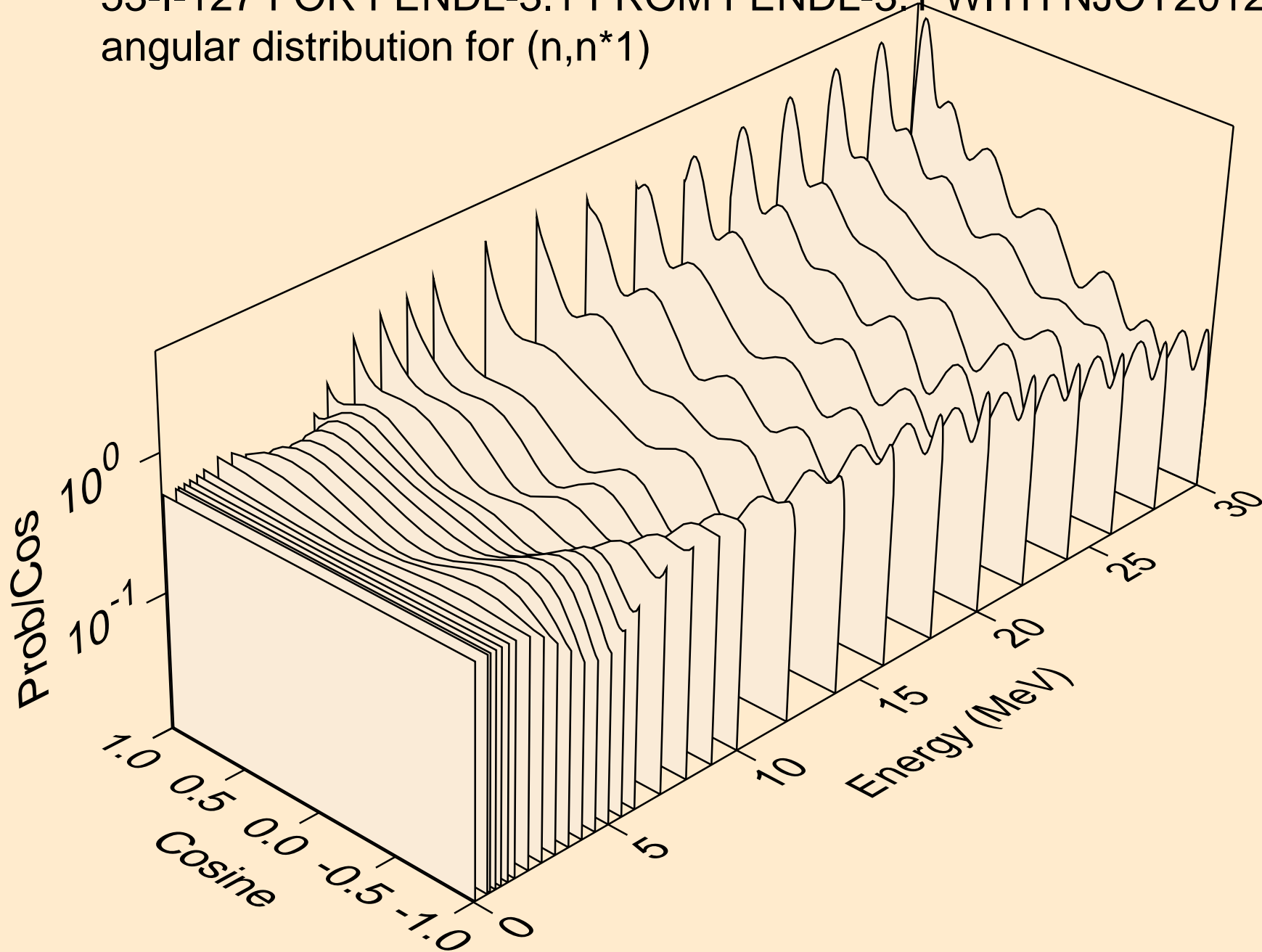

53-I-127 FOR FENDL-3.1 FROM FENDL-3.1 WITH NJOY2012.50+ C  
angular distribution for (n,n\*2)

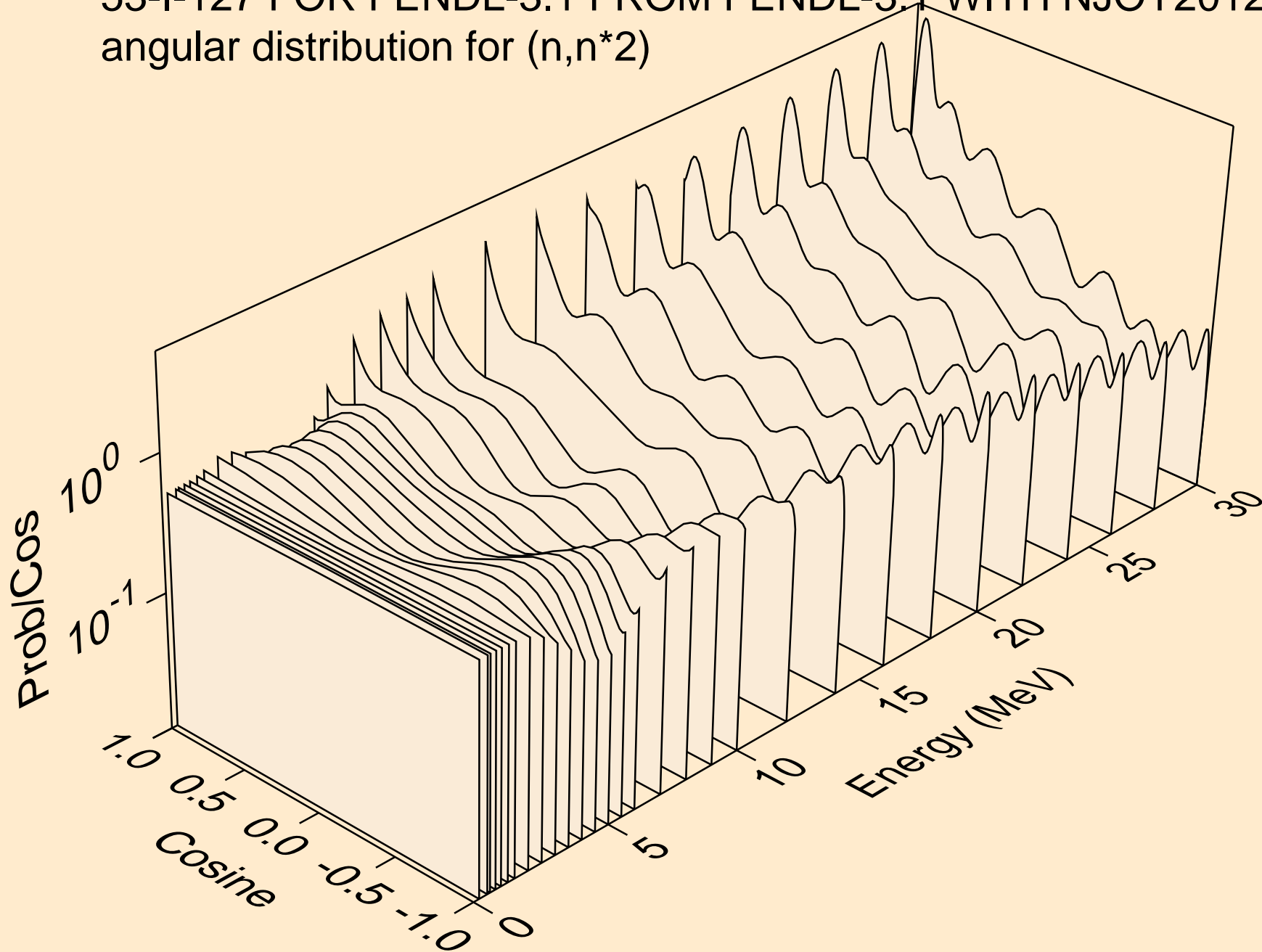



53-I-127 FOR FENDL-3.1 FROM FENDL-3.1 WITH NJOY2012.50+ C  
angular distribution for (n,n\*3)

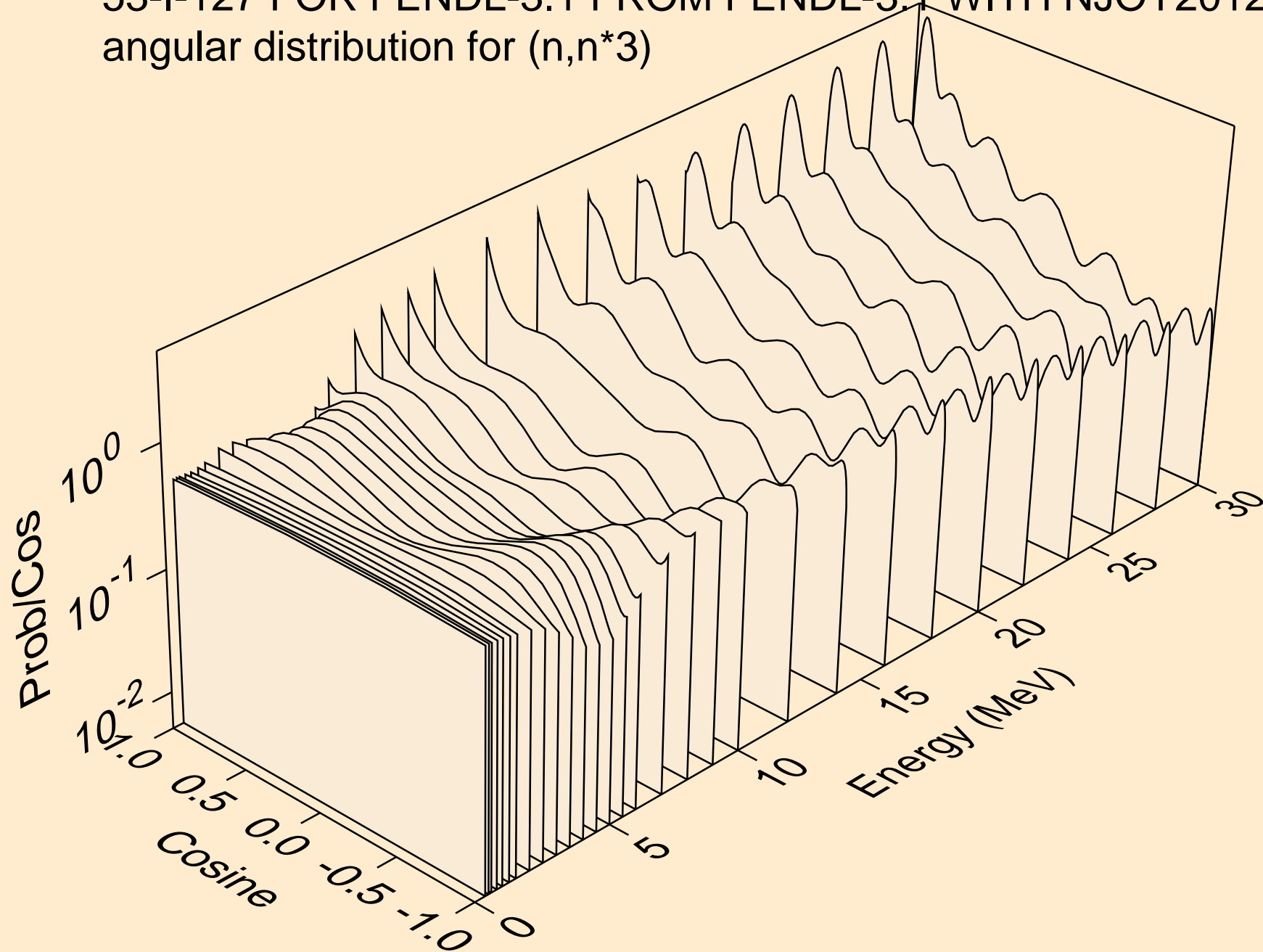

53-I-127 FOR FENDL-3.1 FROM FENDL-3.1 WITH NJOY2012.50+ C  
angular distribution for (n,n\*4)

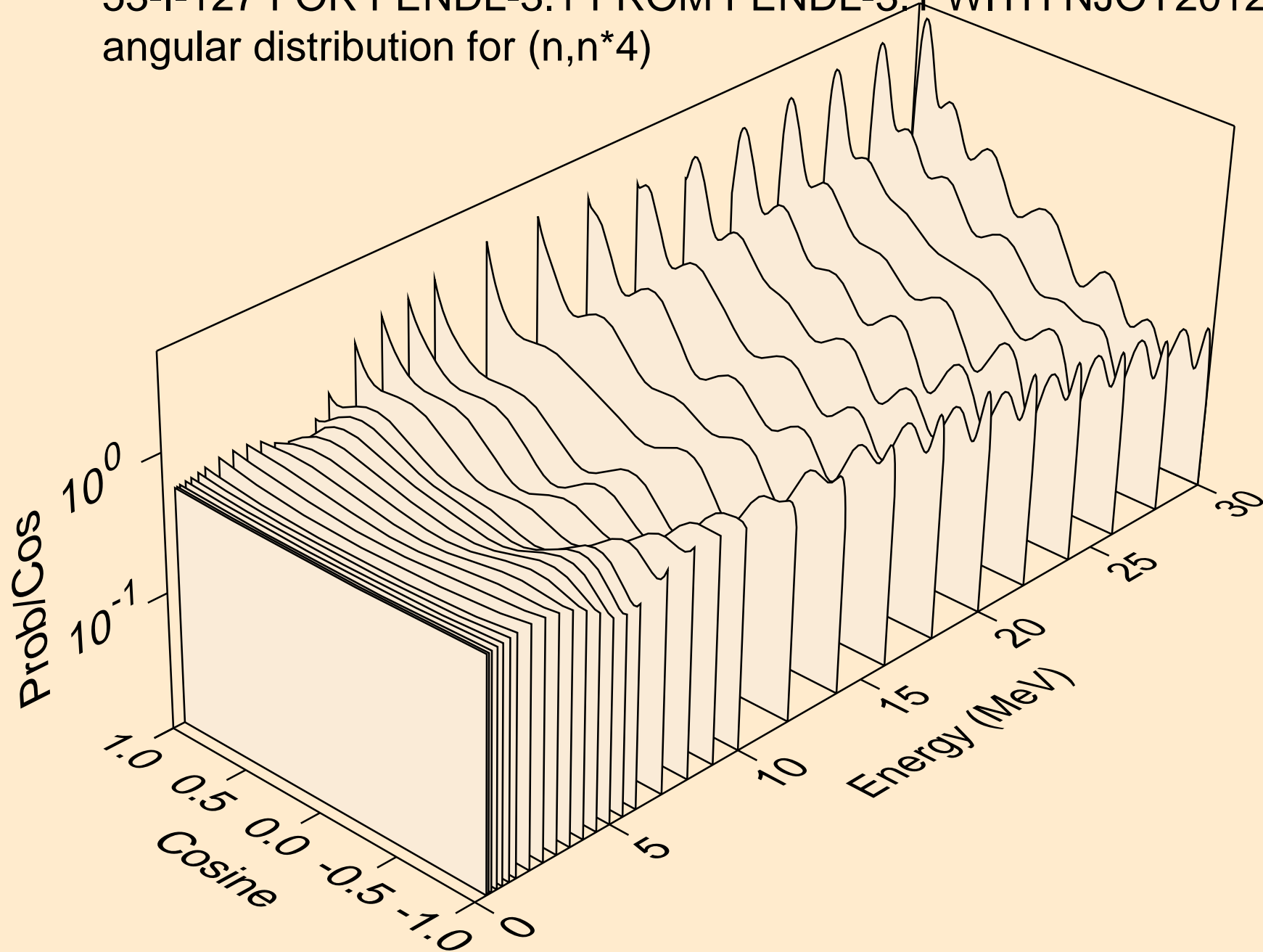

53-I-127 FOR FENDL-3.1 FROM FENDL-3.1 WITH NJOY2012.50+ C  
angular distribution for (n,n\*5)

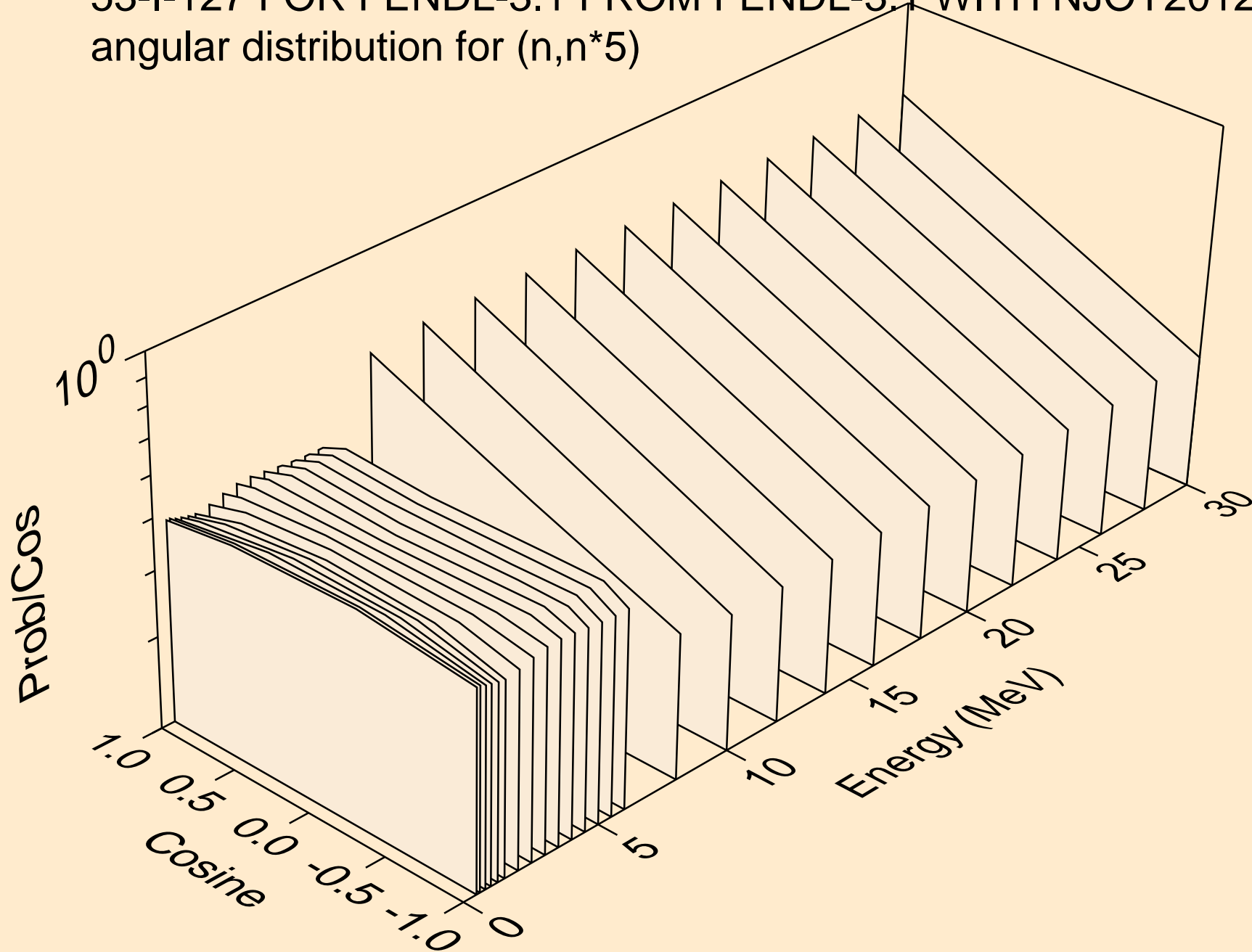

53-I-127 FOR FENDL-3.1 FROM FENDL-3.1 WITH NJOY2012.50+ C  
angular distribution for (n,n\*6)

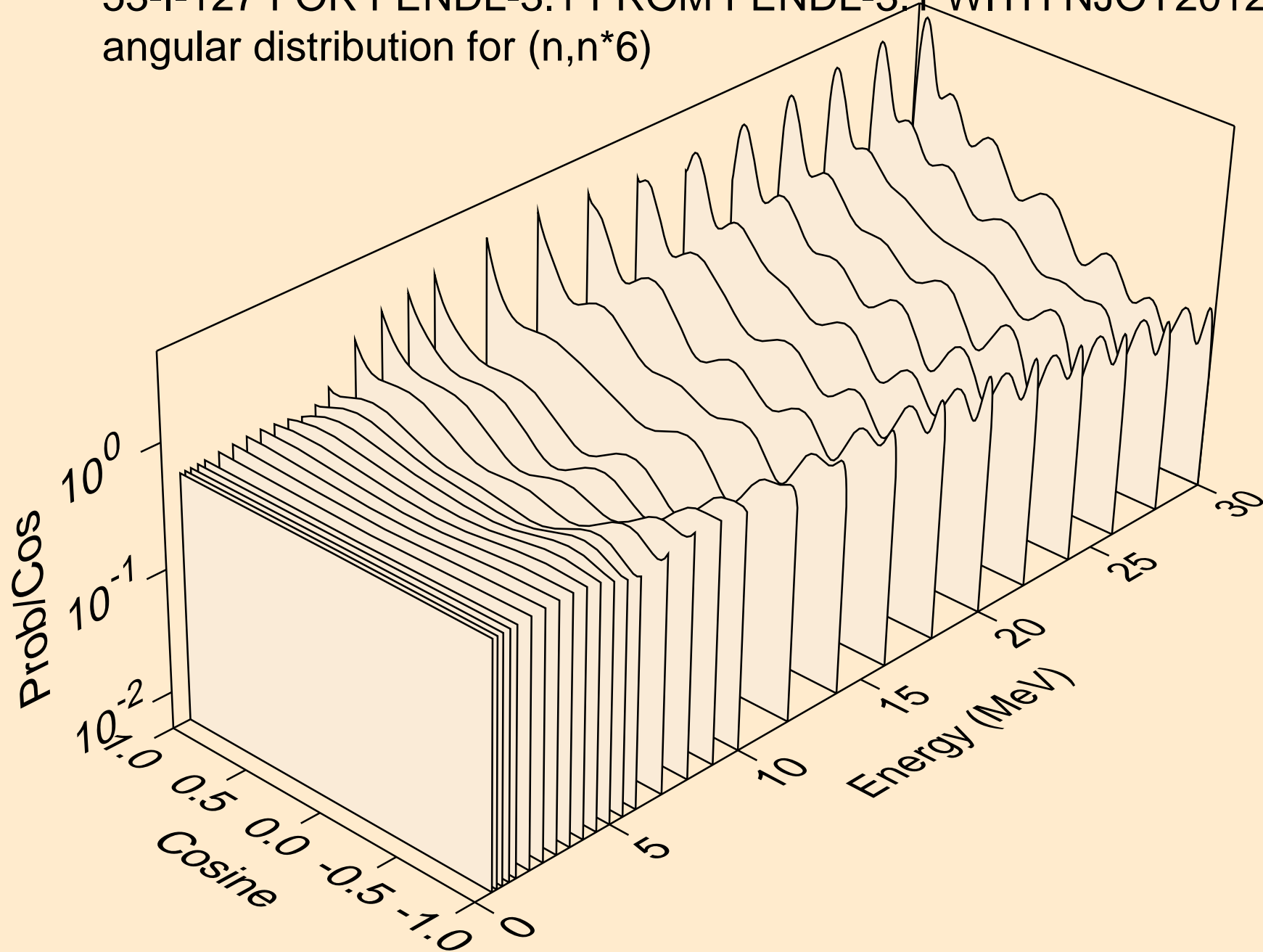

53-I-127 FOR FENDL-3.1 FROM FENDL-3.1 WITH NJOY2012.50+ C  
angular distribution for (n,n\*7)

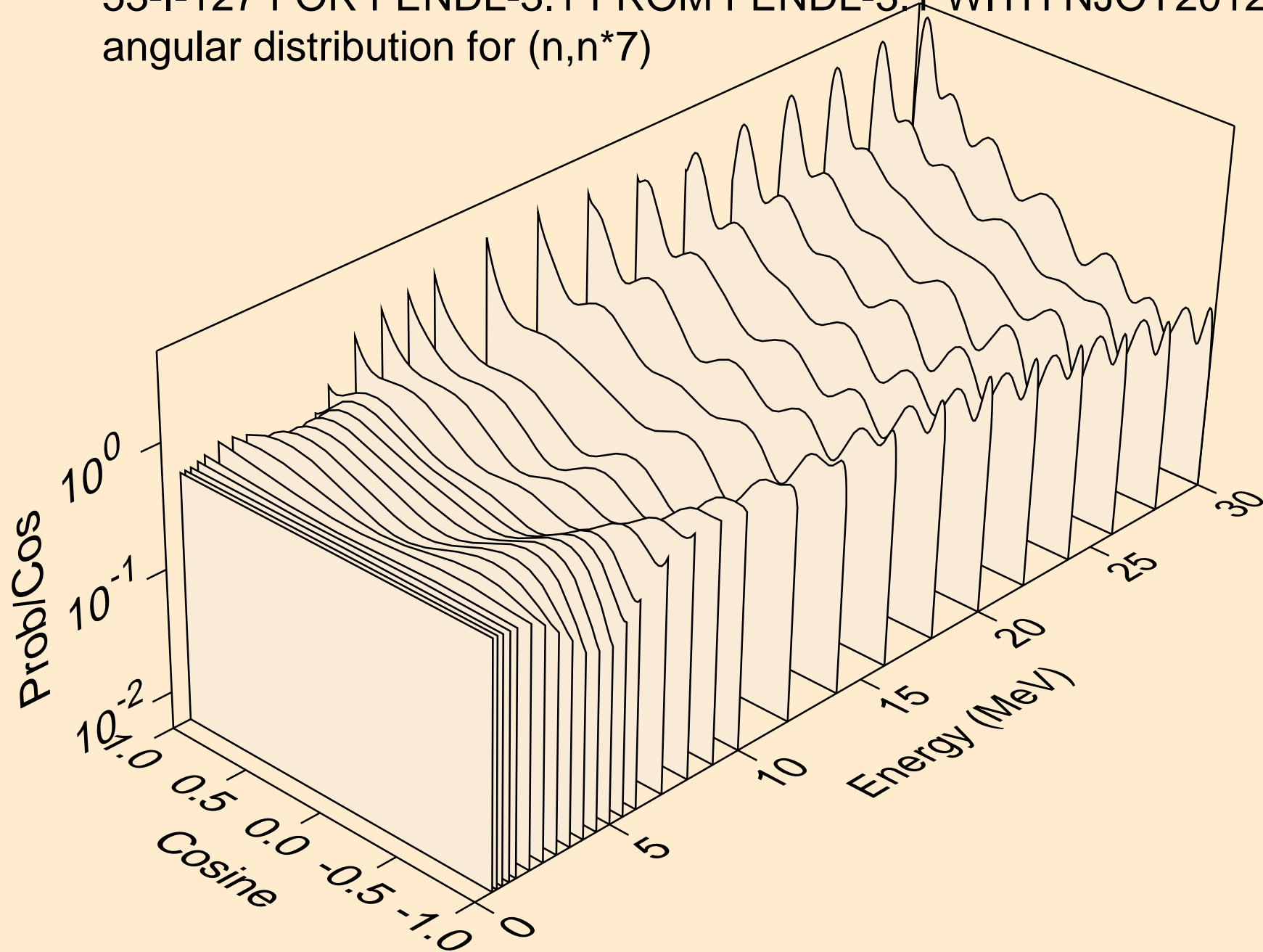

53-I-127 FOR FENDL-3.1 FROM FENDL-3.1 WITH NJOY2012.50+ C  
angular distribution for (n,n\*8)

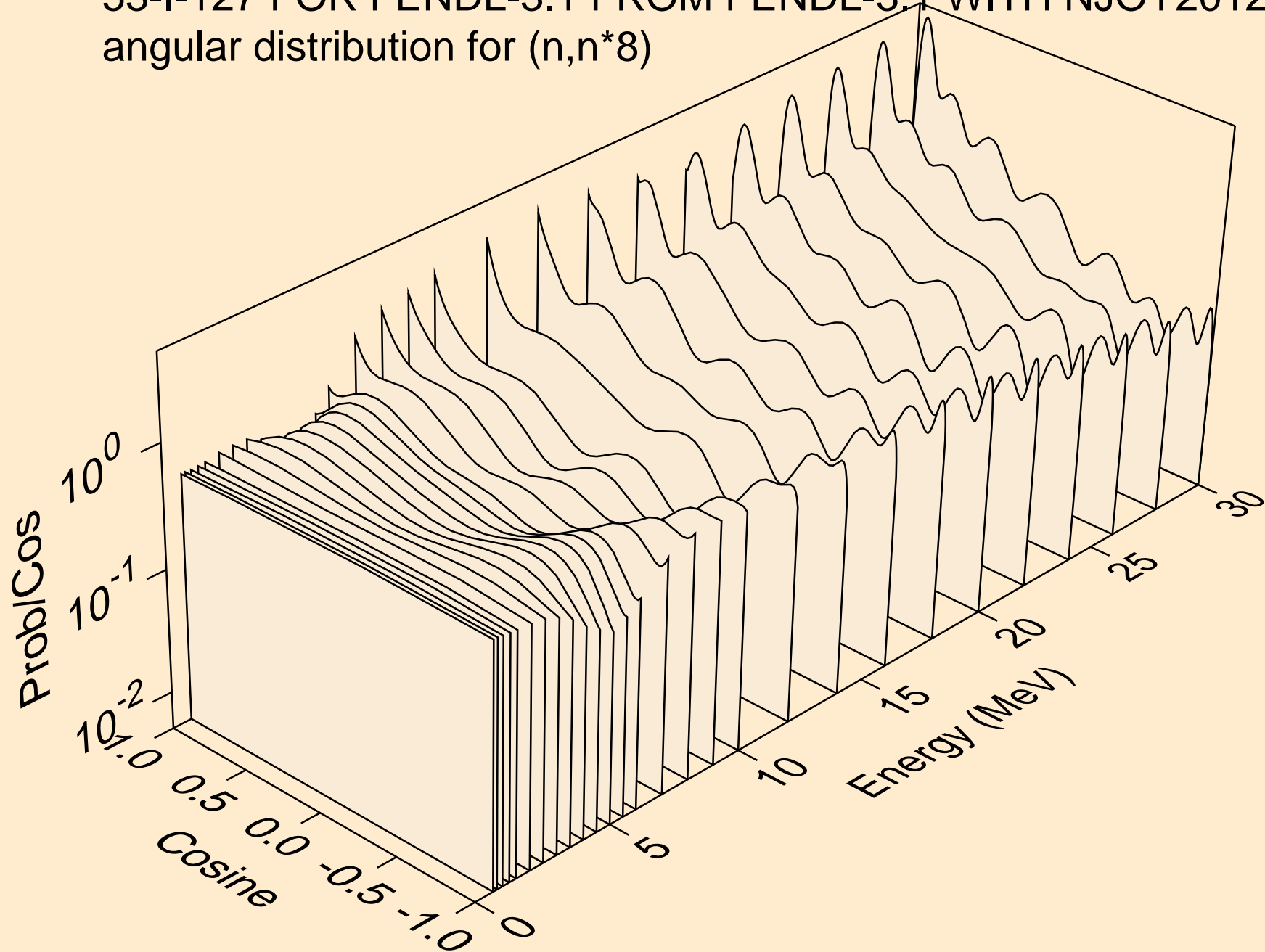

53-I-127 FOR FENDL-3.1 FROM FENDL-3.1 WITH NJOY2012.50+ C  
angular distribution for (n,n\*9)

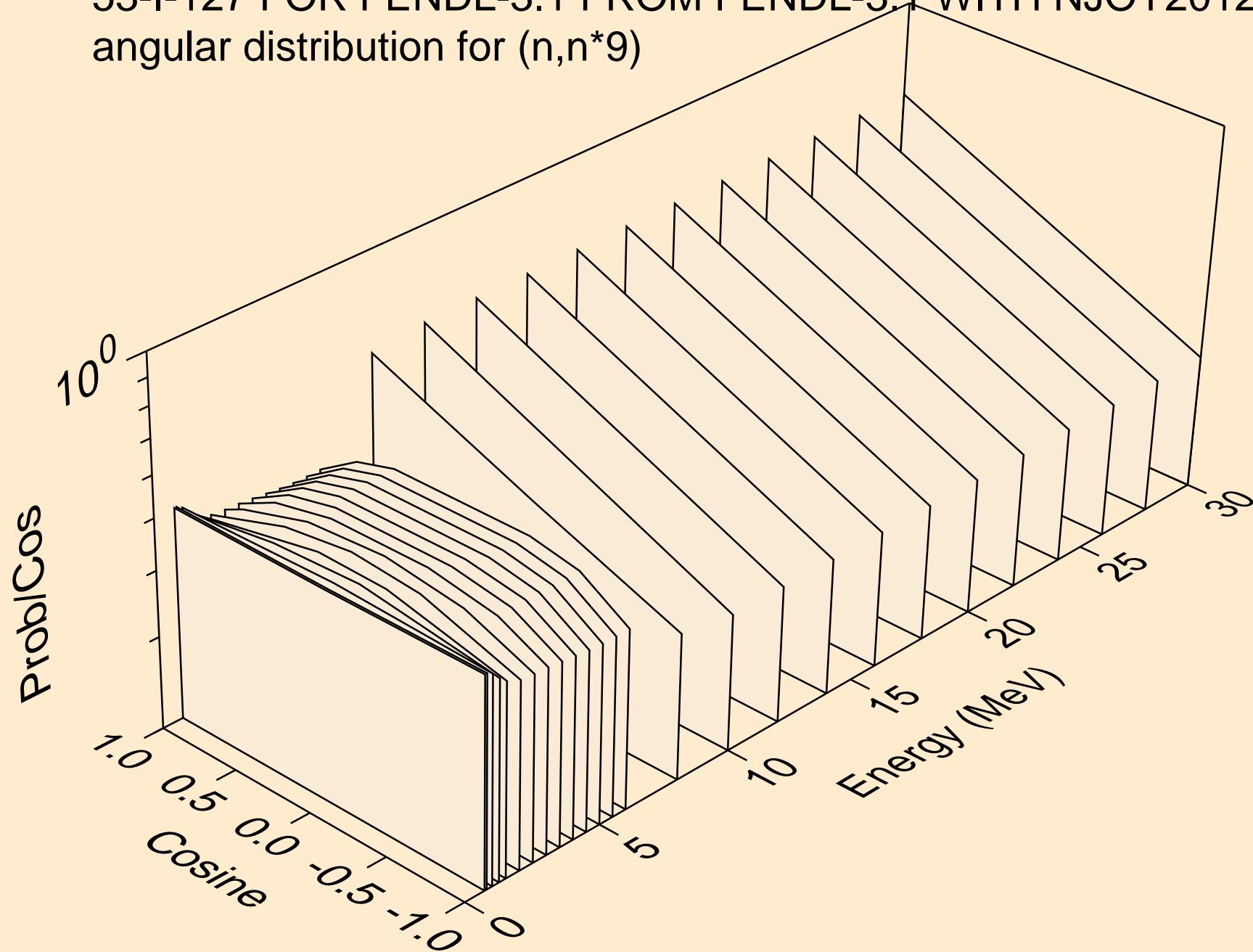

53-I-127 FOR FENDL-3.1 FROM FENDL-3.1 WITH NJOY2012.50+ C  
angular distribution for (n,n\*10)

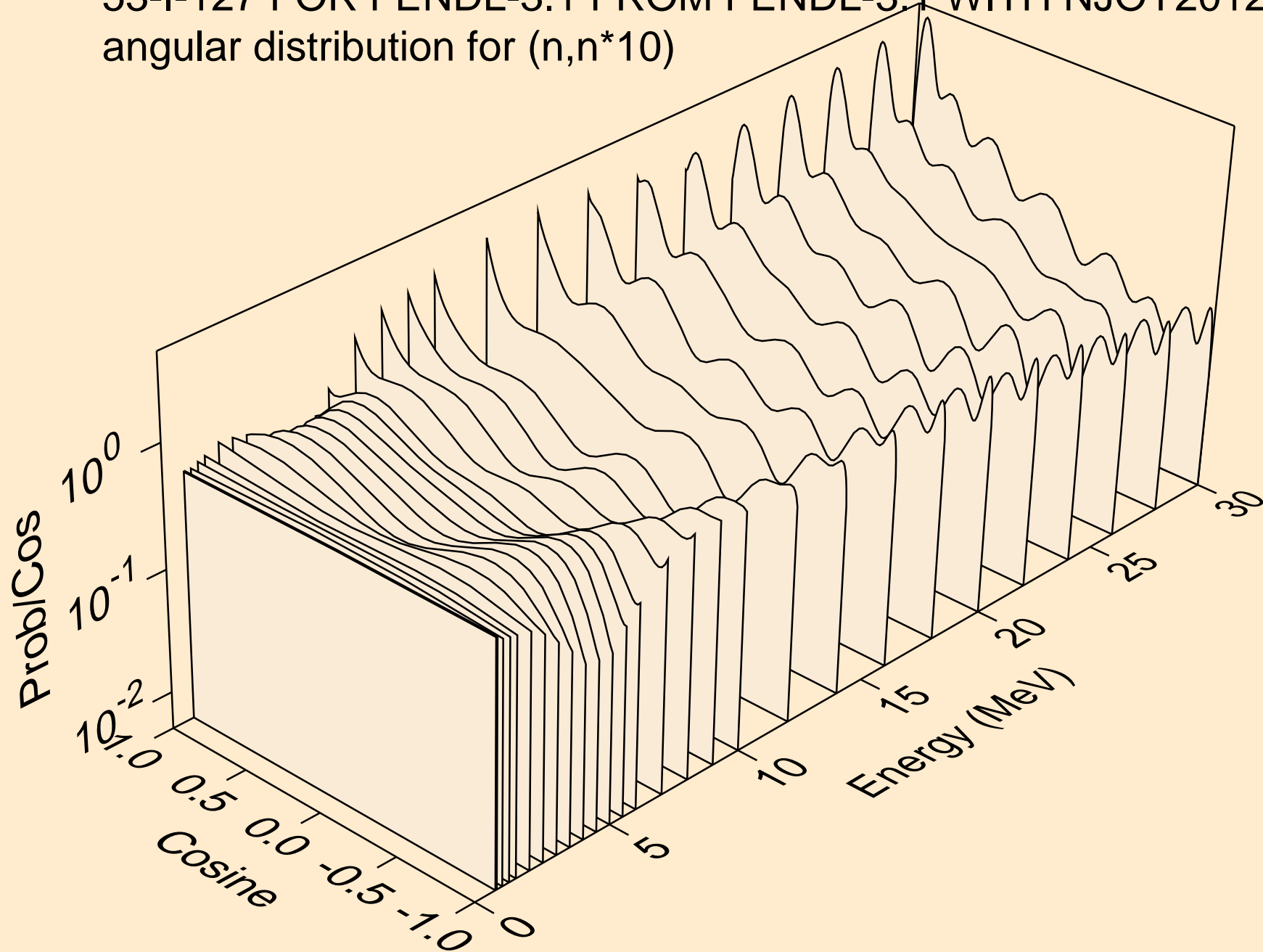



53-I-127 FOR FENDL-3.1 FROM FENDL-3.1 WITH NJOY2012.50+ C  
angular distribution for (n,n\*11)

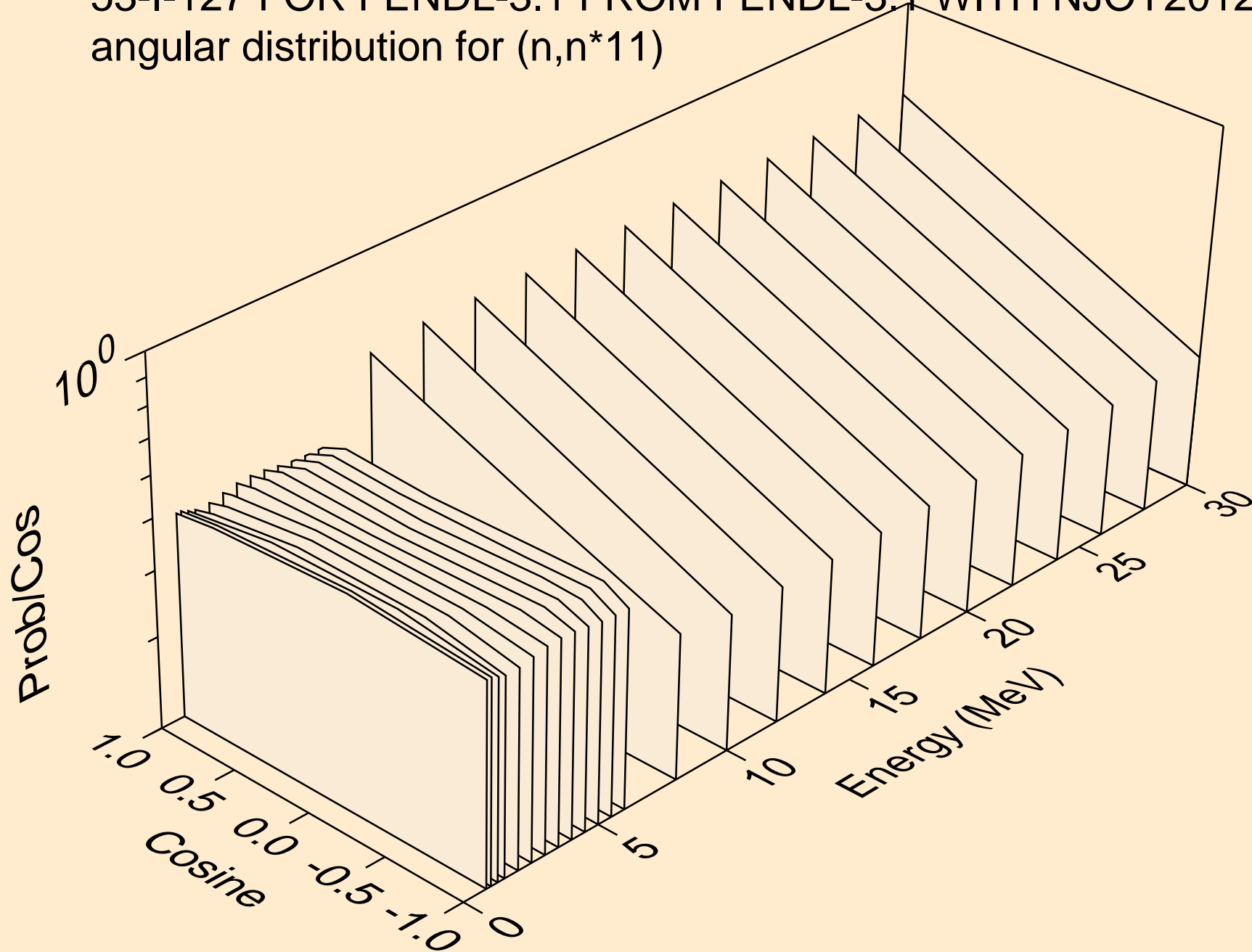

53-I-127 FOR FENDL-3.1 FROM FENDL-3.1 WITH NJOY2012.50+ C  
angular distribution for (n,n\*12)

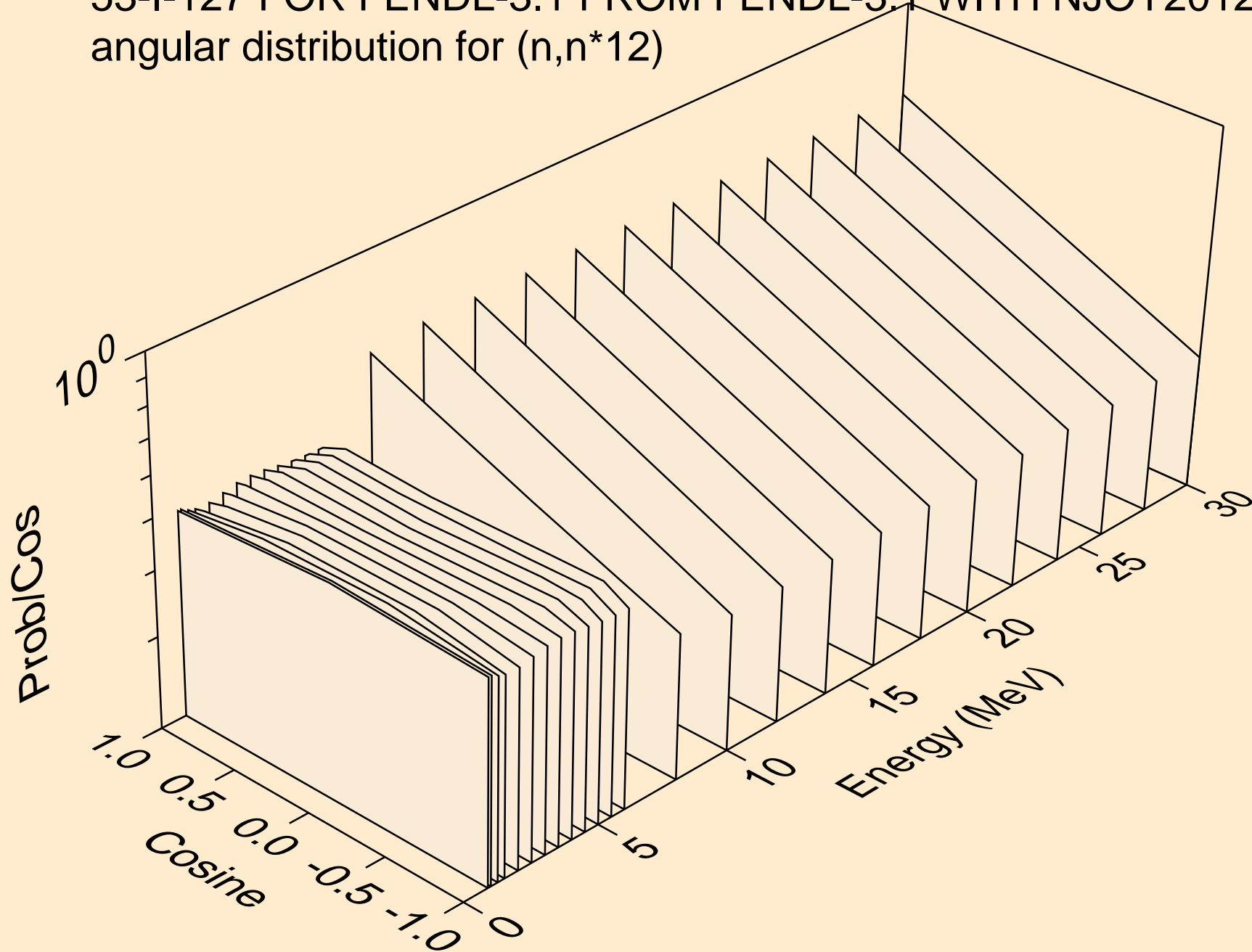

53-I-127 FOR FENDL-3.1 FROM FENDL-3.1 WITH NJOY2012.50+ C  
angular distribution for (n,n\*13)

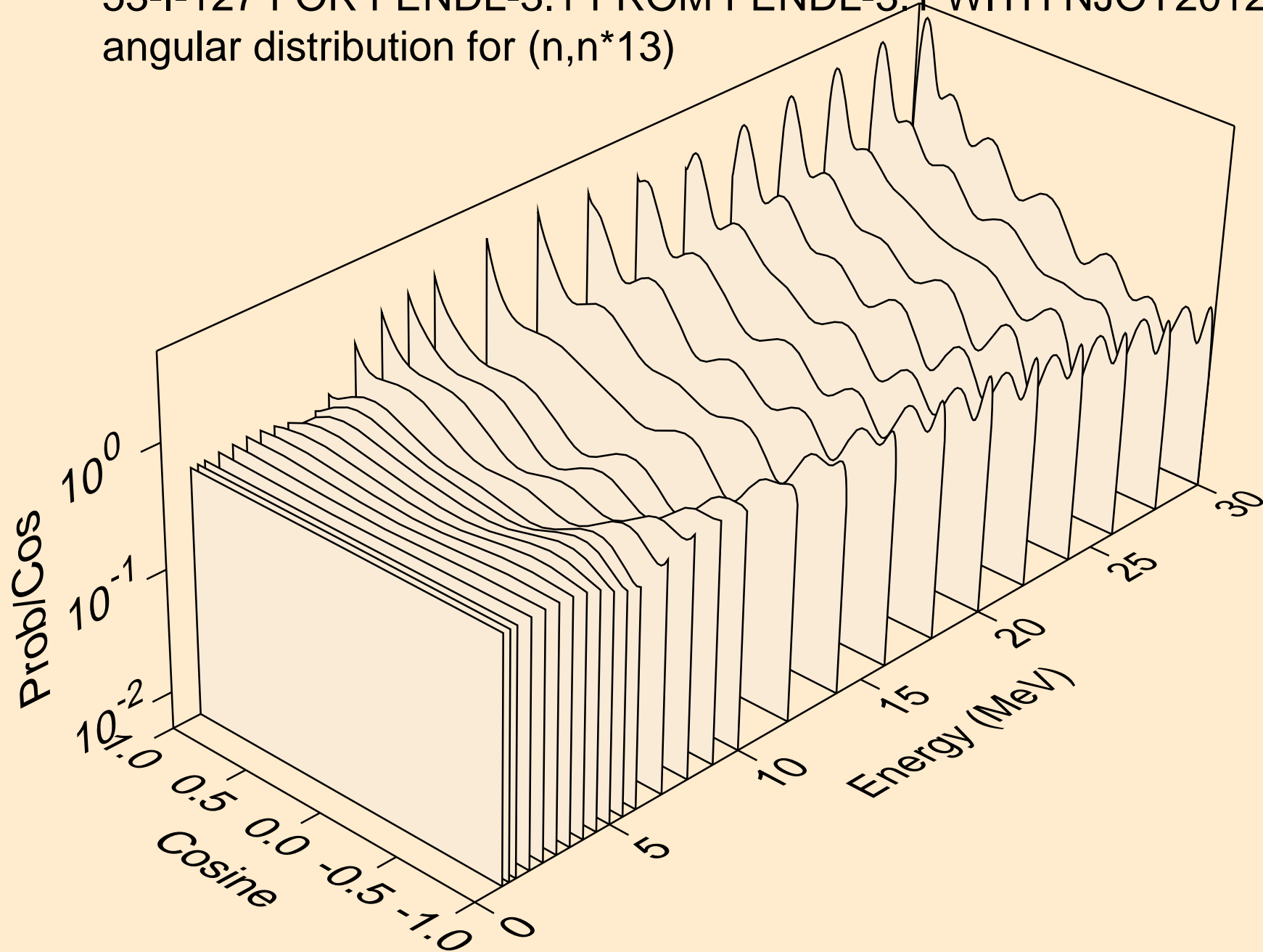

53-I-127 FOR FENDL-3.1 FROM FENDL-3.1 WITH NJOY2012.50+ ( )  
angular distribution for (n,n\*14)

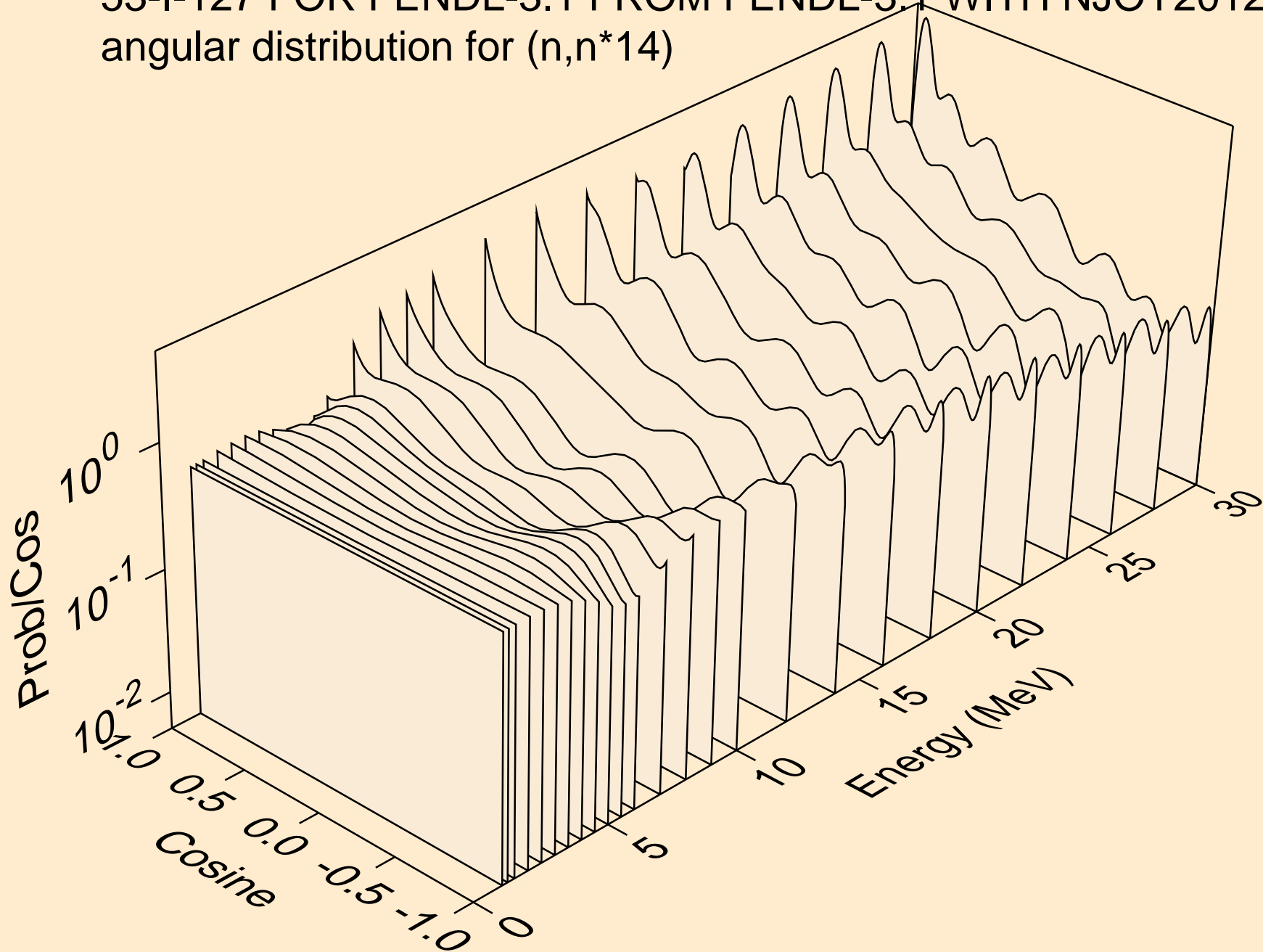

53-I-127 FOR FENDL-3.1 FROM FENDL-3.1 WITH NJOY2012.50+  
angular distribution for (n,n\*15)

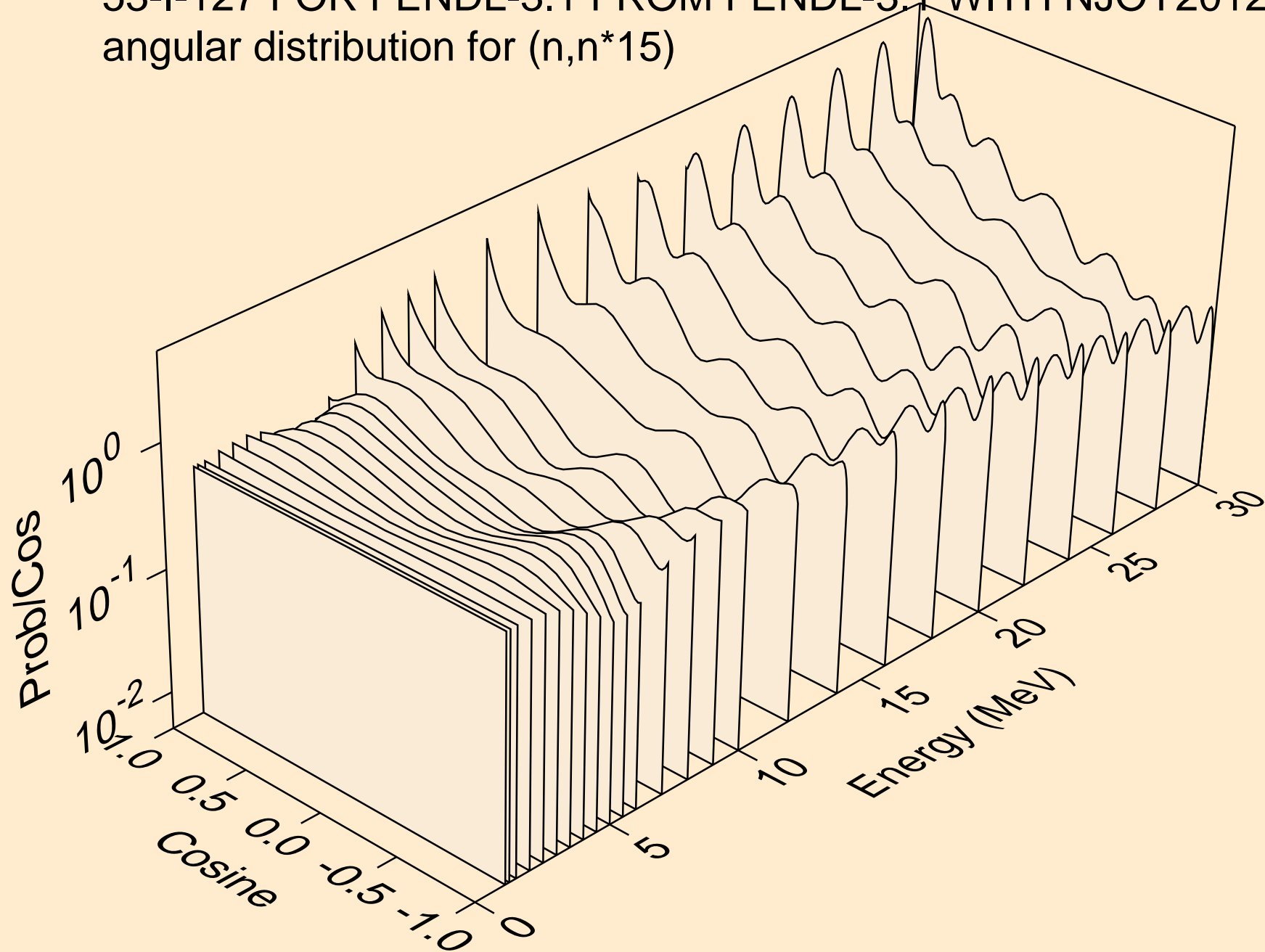

53-I-127 FOR FENDL-3.1 FROM FENDL-3.1 WITH NJOY2012.50+ C  
angular distribution for (n,n\*16)

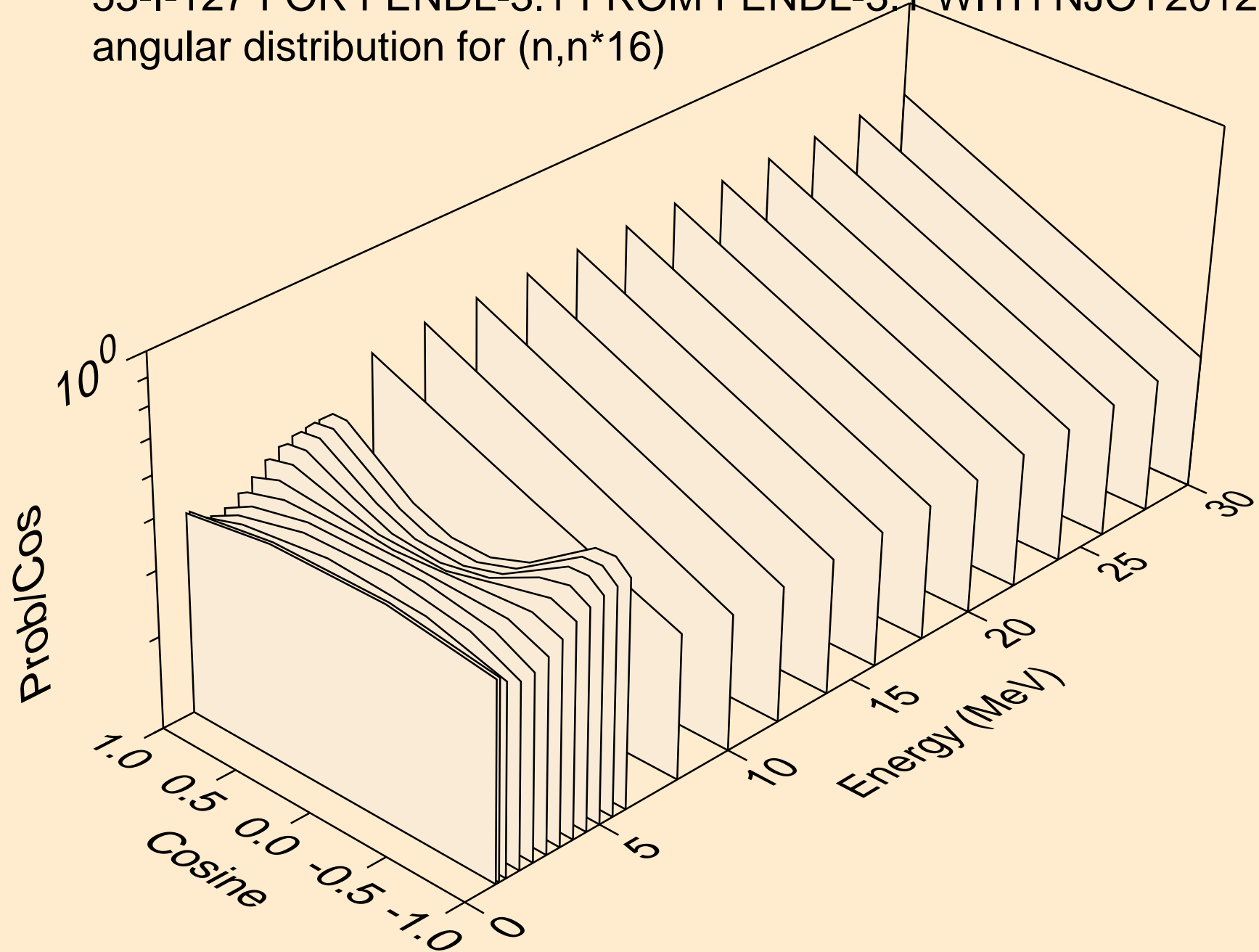

53-I-127 FOR FENDL-3.1 FROM FENDL-3.1 WITH NJOY2012.50+ C  
angular distribution for (n,n\*17)

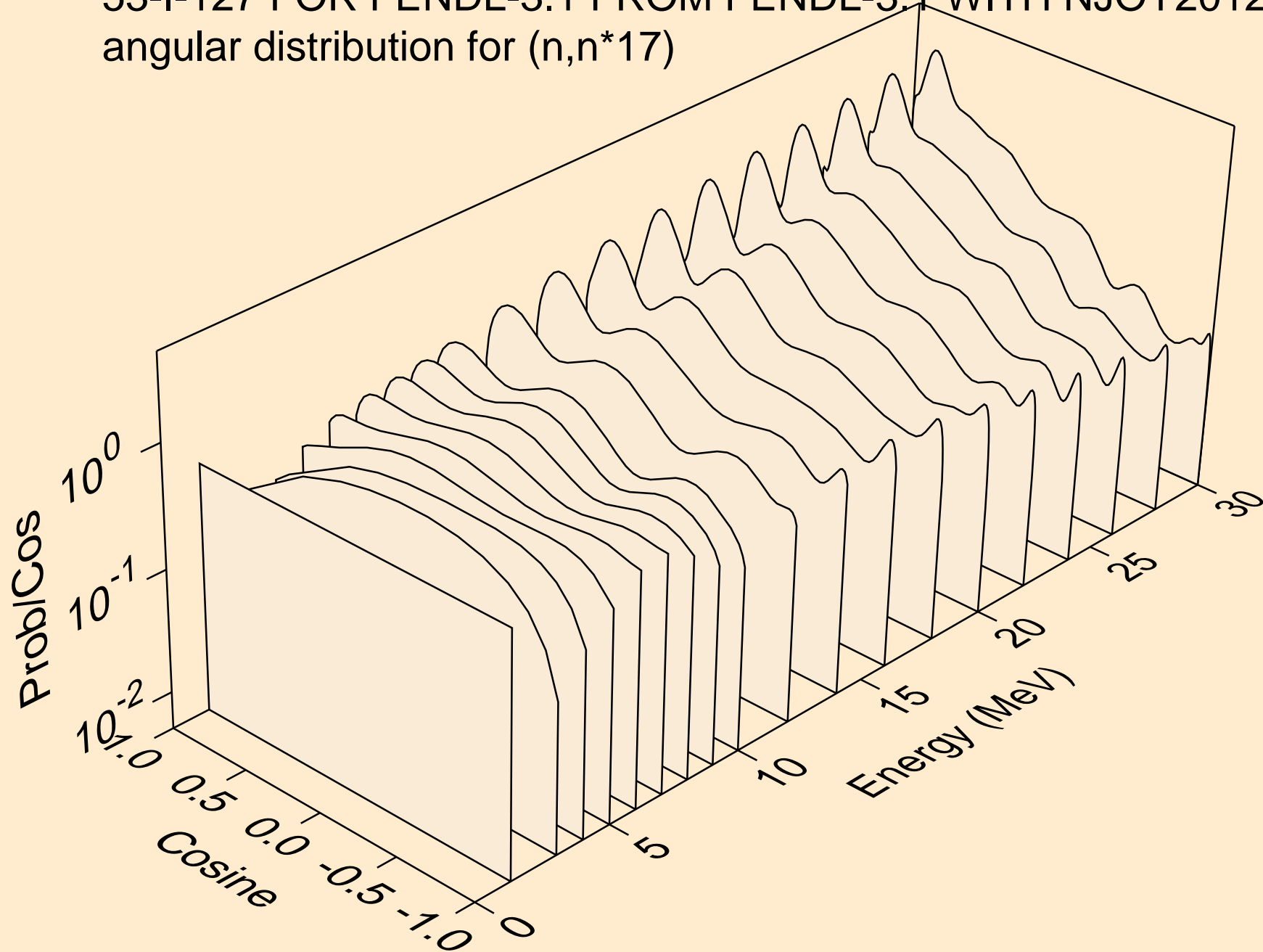

53-I-127 FOR FENDL-3.1 FROM FENDL-3.1 WITH NJOY2012.50+ C  
angular distribution for (n,n\*18)

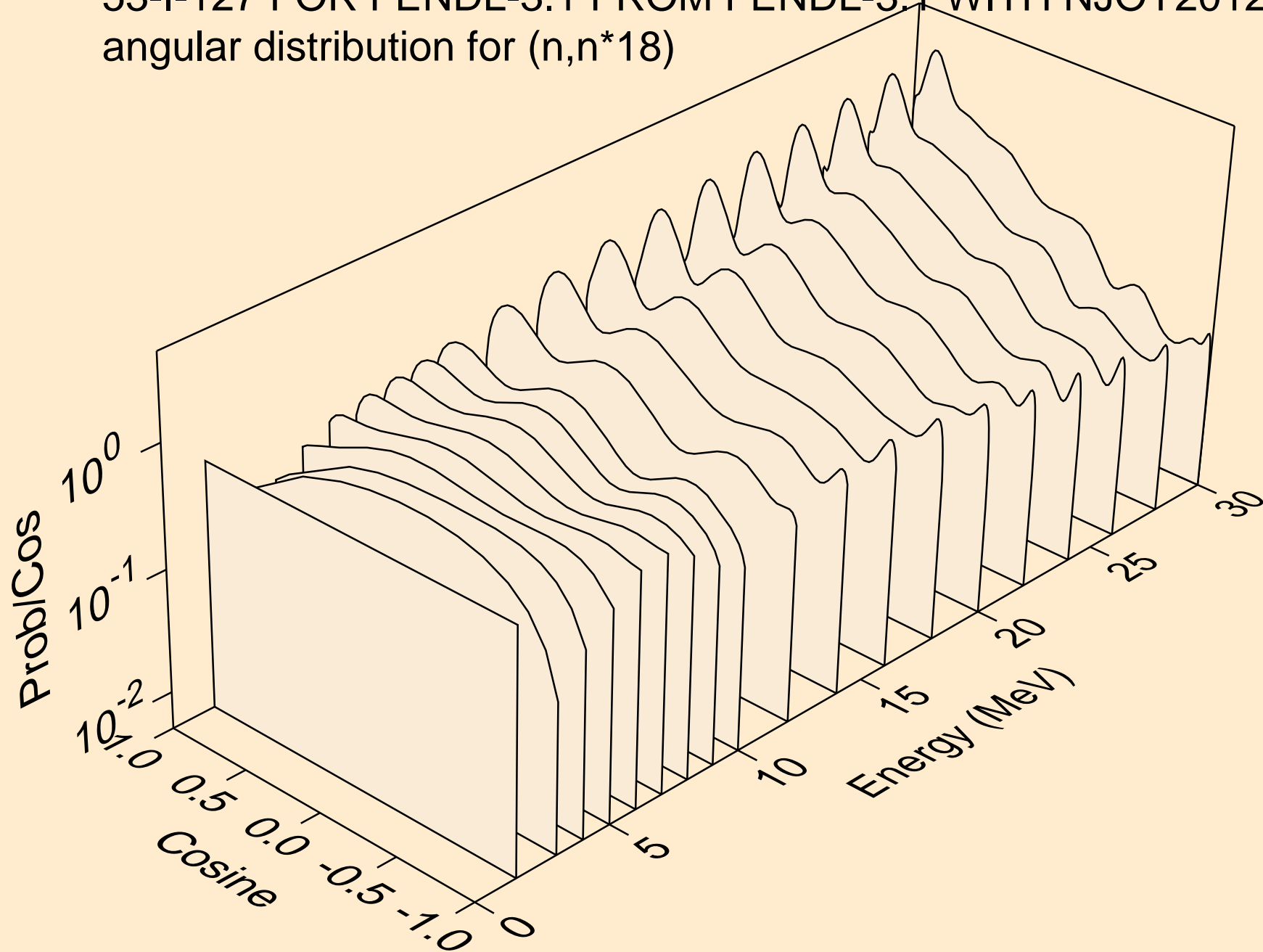



53-I-127 FOR FENDL-3.1 FROM FENDL-3.1 WITH NJOY2012.50+ C  
angular distribution for (n,n\*19)

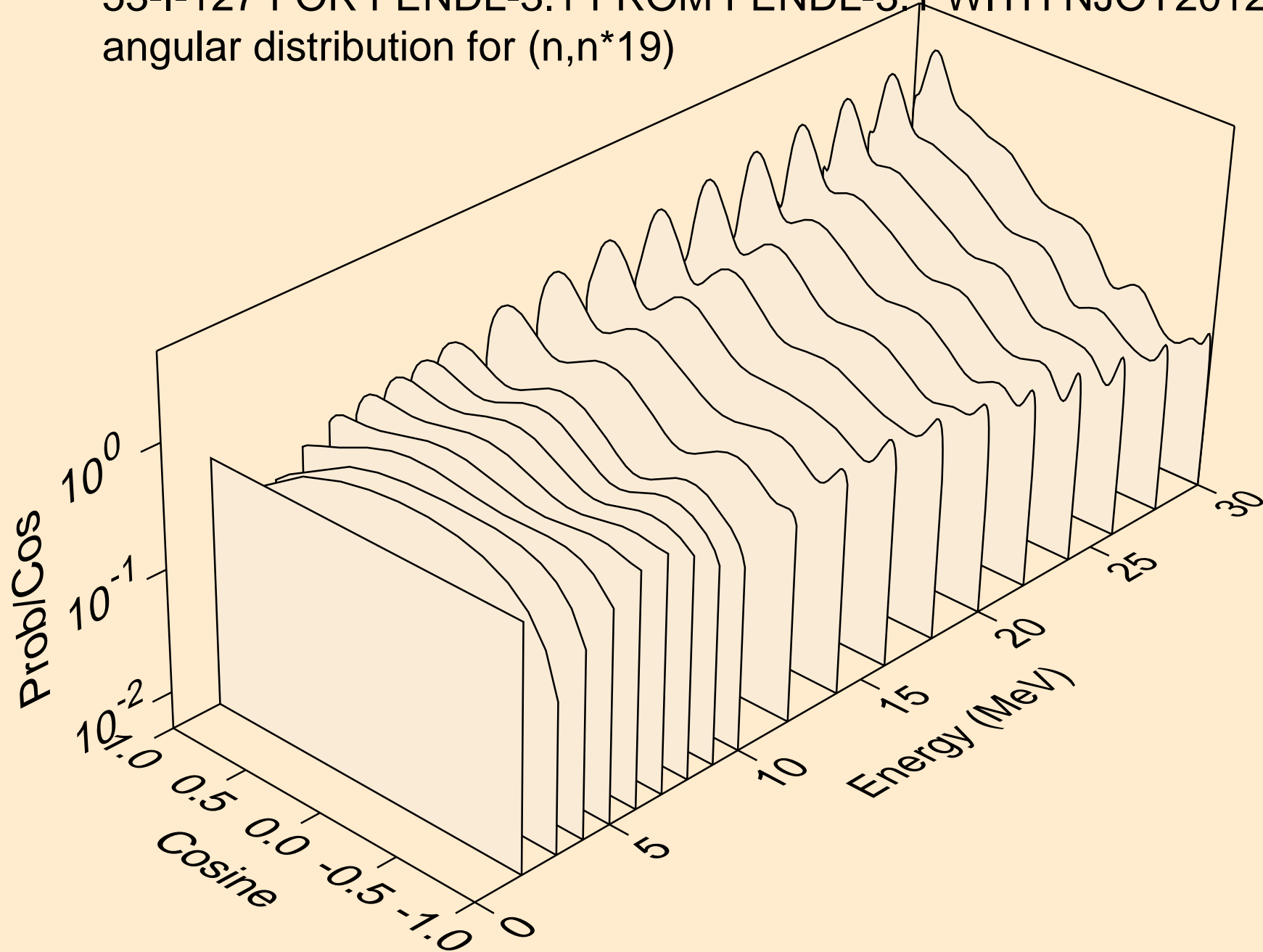

53-I-127 FOR FENDL-3.1 FROM FENDL-3.1 WITH NJOY2012.50+ C  
angular distribution for (n,n\*20)

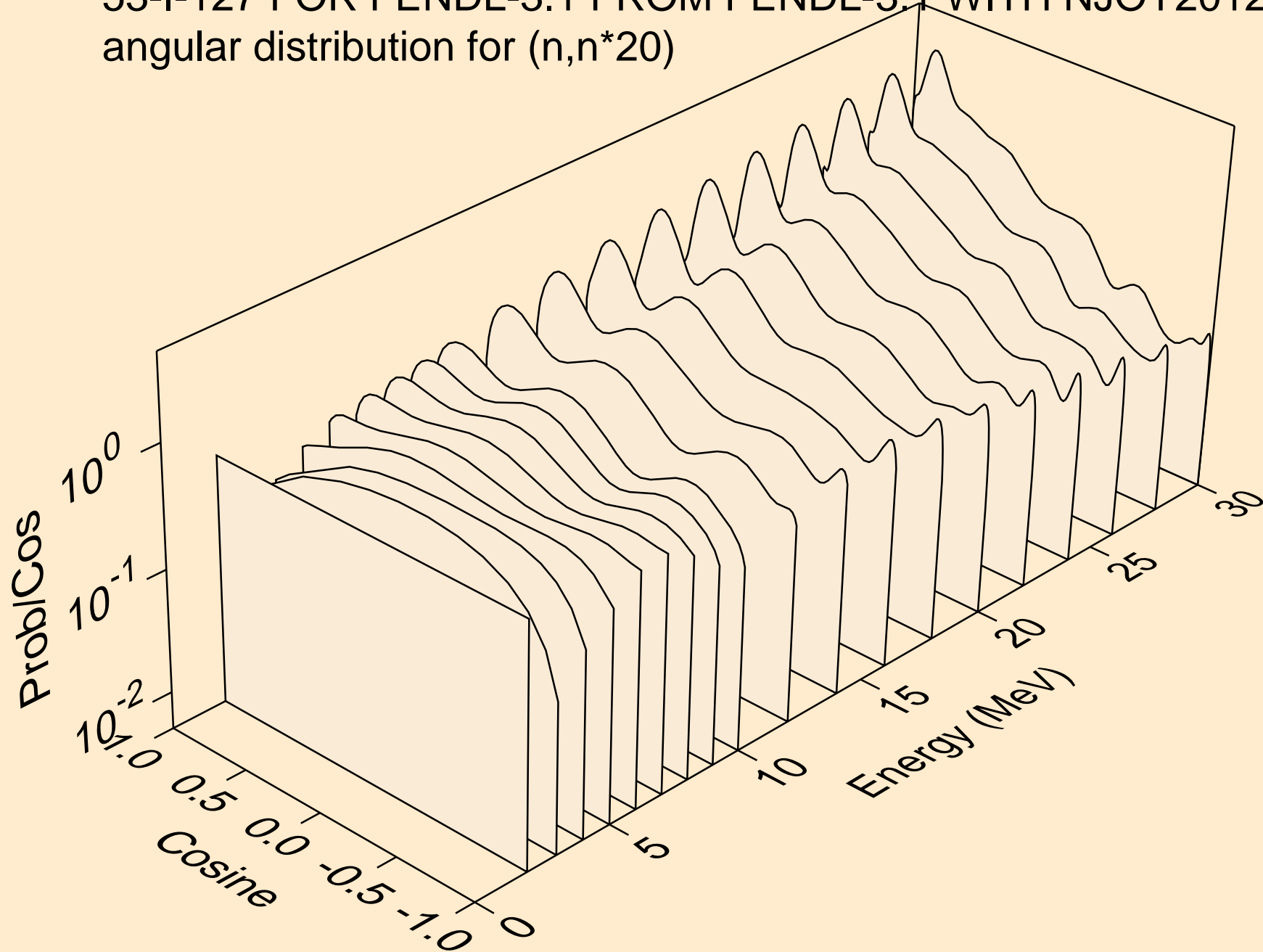

53-I-127 FOR FENDL-3.1 FROM FENDL-3.1 WITH NJOY2012.50+ C  
angular distribution for (n,n\*21)

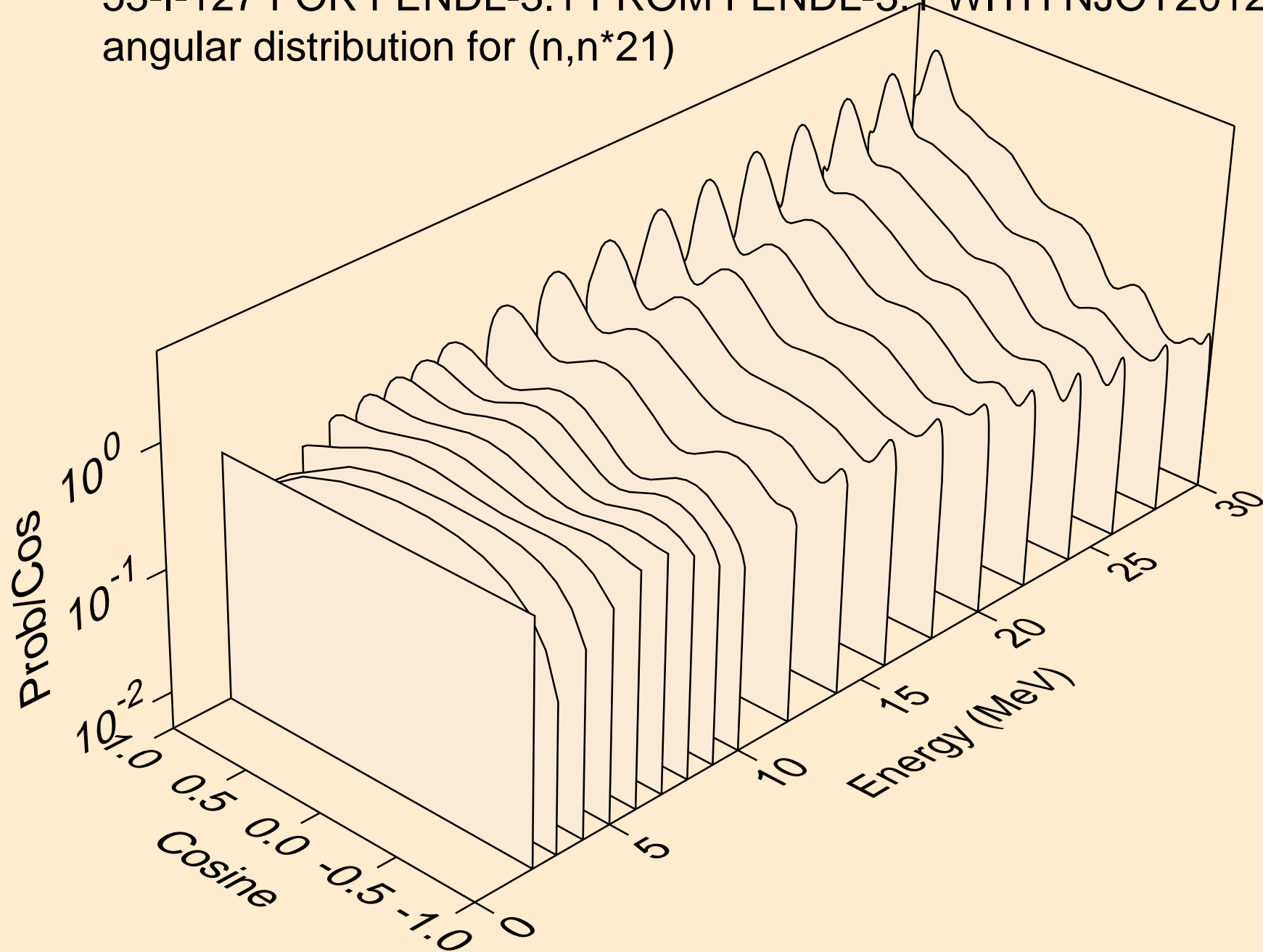

53-I-127 FOR FENDL-3.1 FROM FENDL-3.1 WITH NJOY2012.50+ C  
Neutron emission for (n,x)

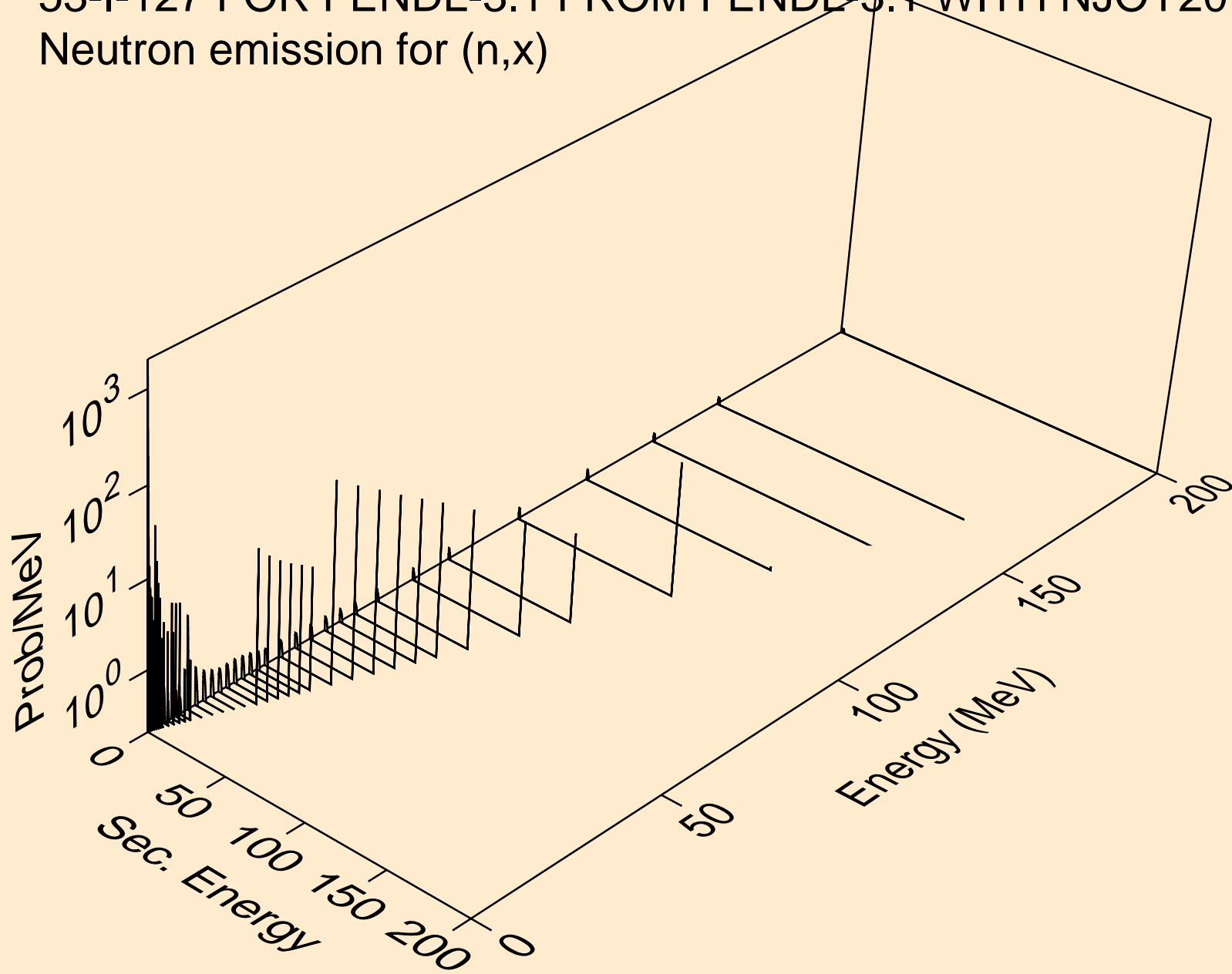

53-I-127 FOR FENDL-3.1 FROM FENDL-3.1 WITH NJOY2012.50+ C  
Neutron emission for (n,2n)

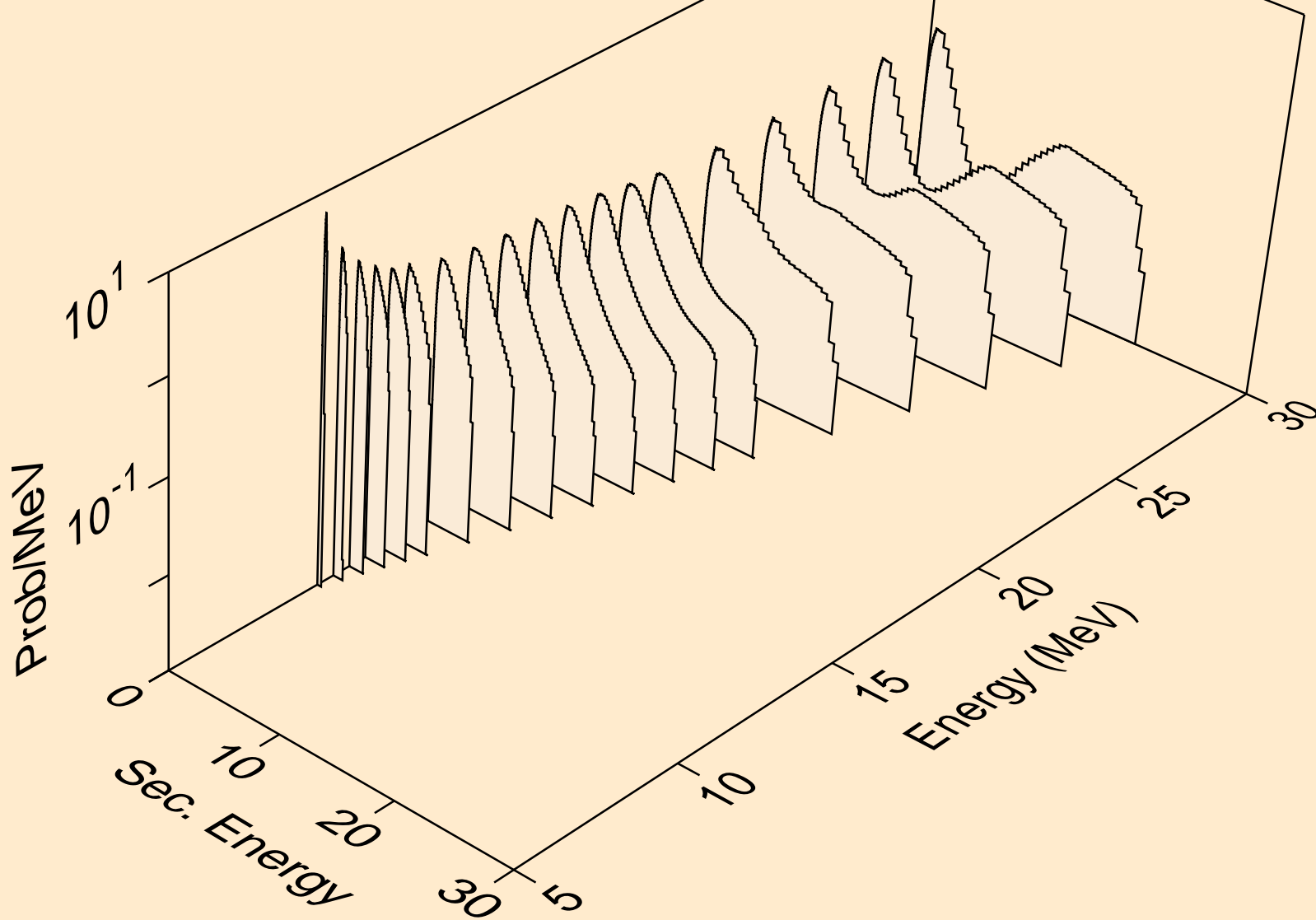

53-I-127 FOR FENDL-3.1 FROM FENDL-3.1 WITH NJOY2012.50+ C  
Neutron emission for (n,3n)

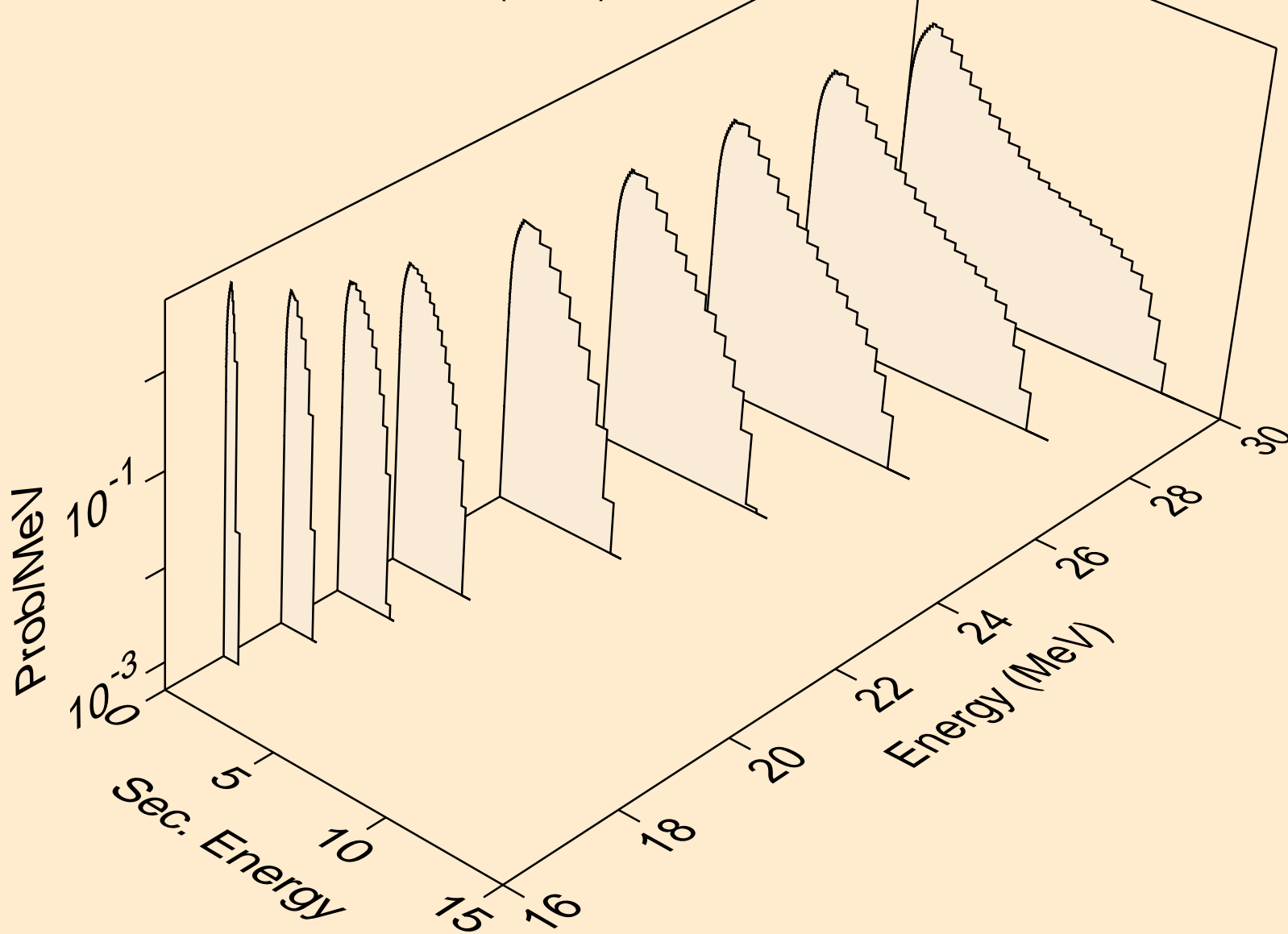

53-I-127 FOR FENDL-3.1 FROM FENDL-3.1 WITH NJOY2012.50+ C  
Neutron emission for (n,n\*)a

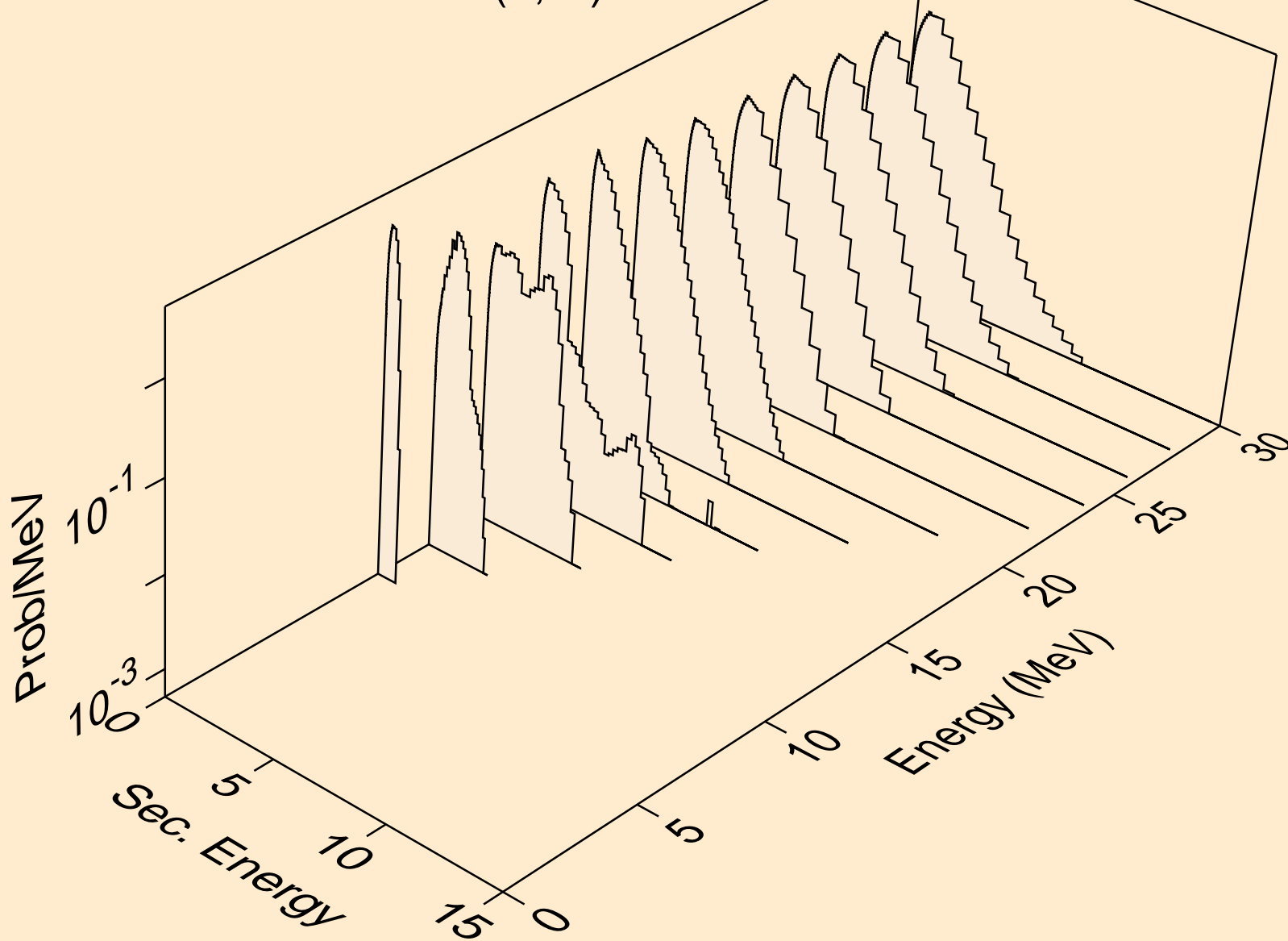

53-I-127 FOR FENDL-3.1 FROM FENDL-3.1 WITH NJOY2012.50+ C  
Neutron emission for (n,n\*)p

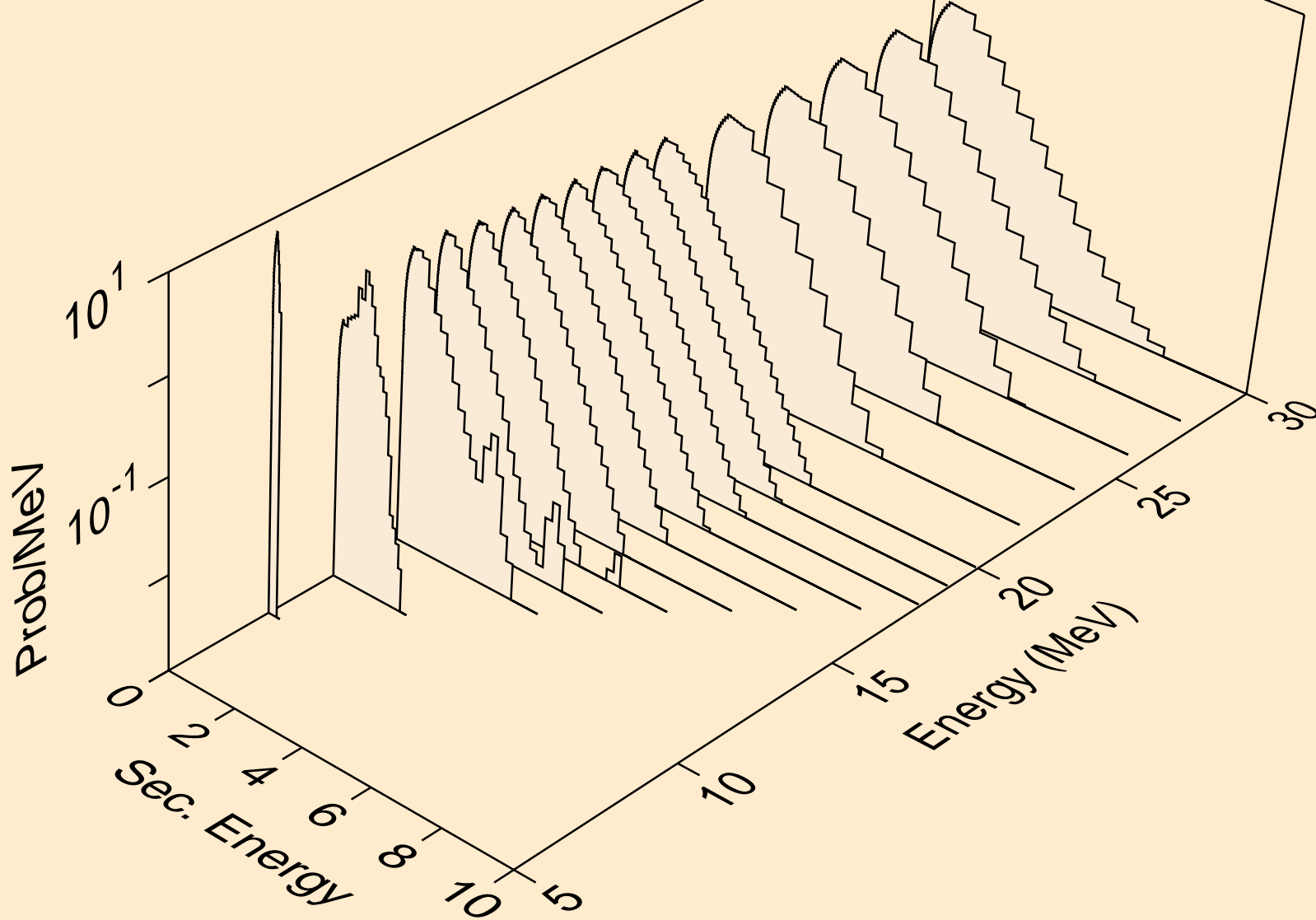



53-I-127 FOR FENDL-3.1 FROM FENDL-3.1 WITH NJOY2012.50+ C  
Neutron emission for (n,4n)

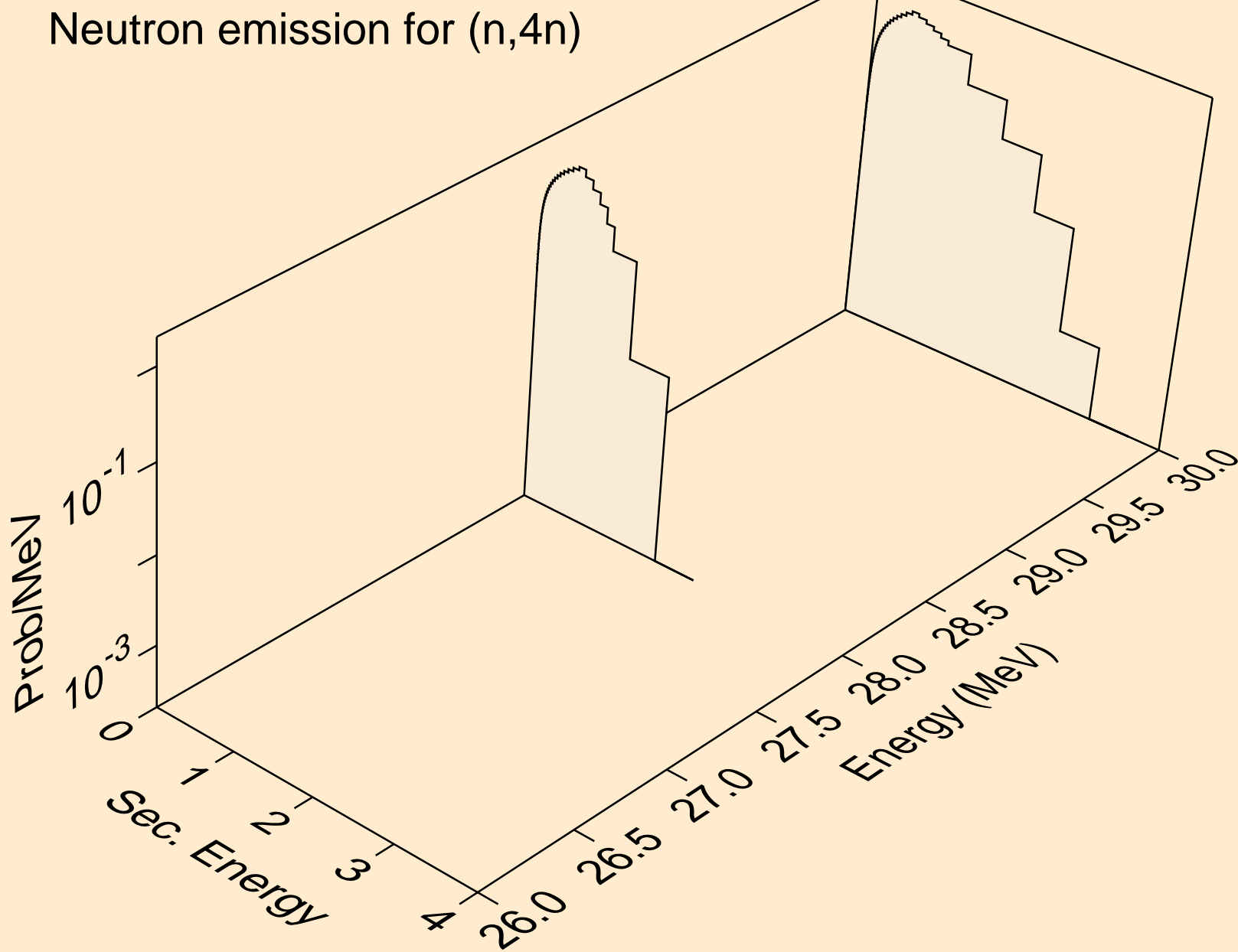

53-I-127 FOR FENDL-3.1 FROM FENDL-3.1 WITH NJOY2012.50+ C  
Neutron emission for (n,n\*c)

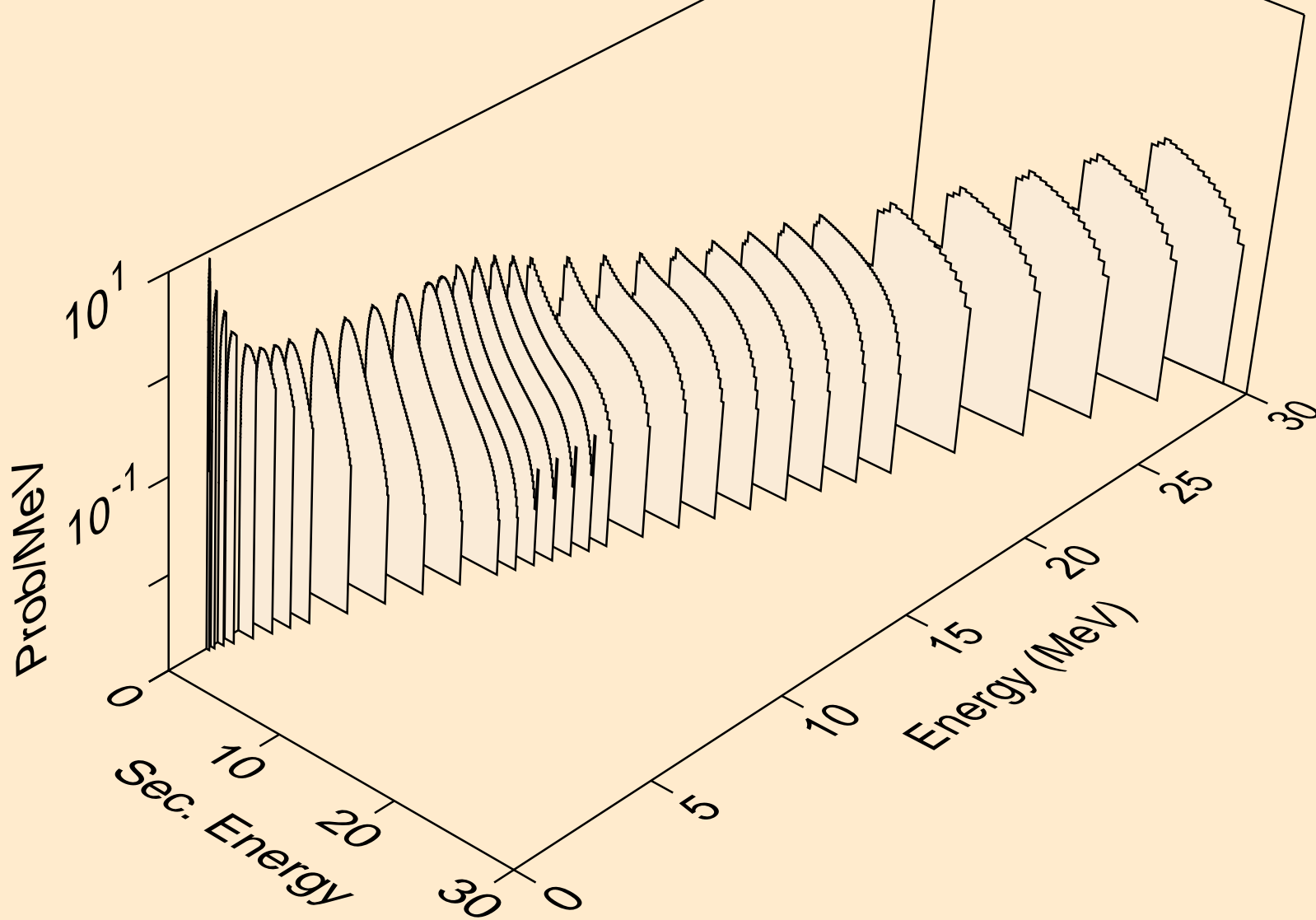

53-I-127 FOR FENDL-3.1 FROM FENDL-3.1 WITH NJOY2012.50+ C  
Photon emission for (n,gma)

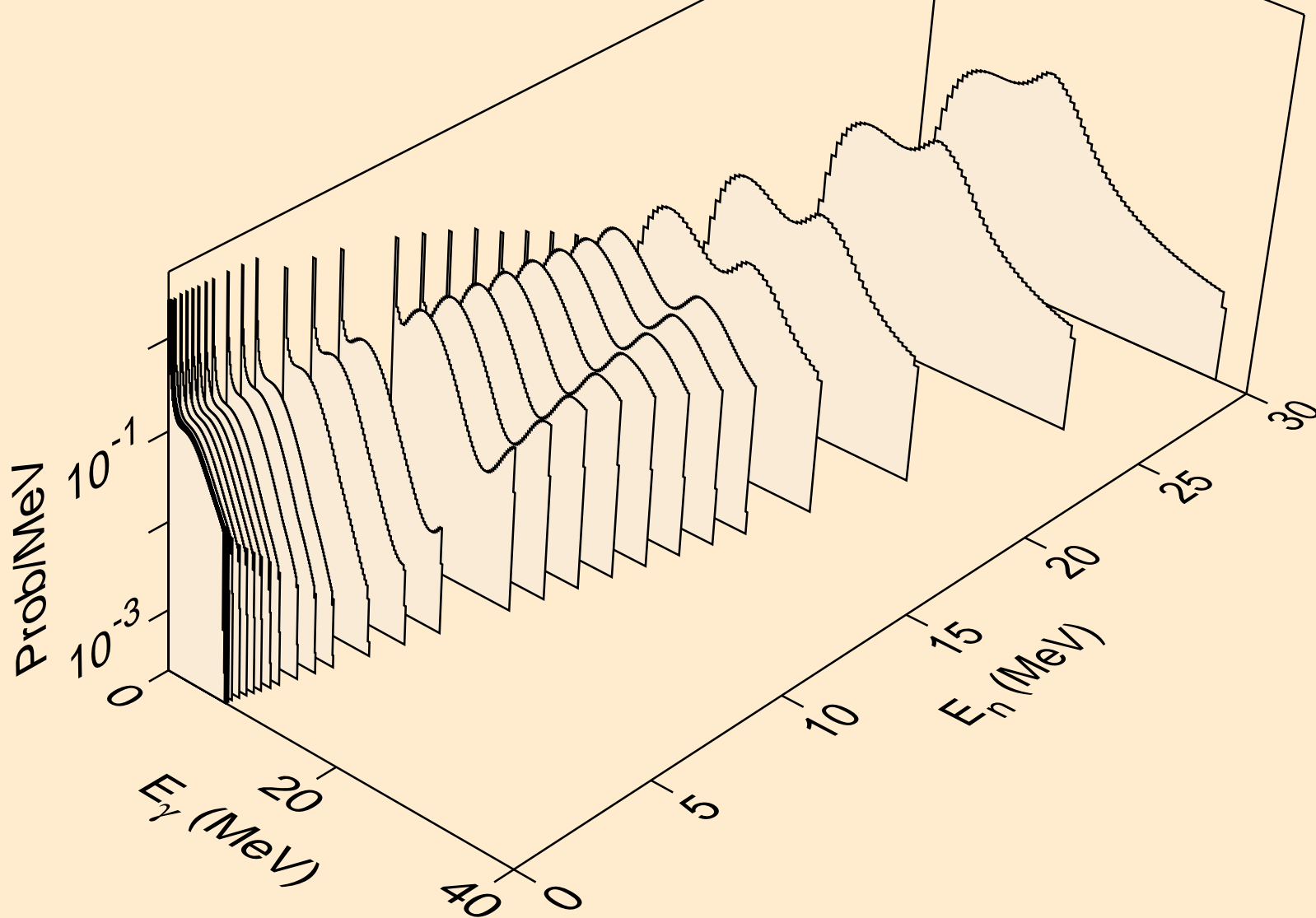

53-I-127 FOR FENDL-3.1 FROM FENDL-3.1 WITH NJOY2012.50+ C  
Photon emission for (n,x)

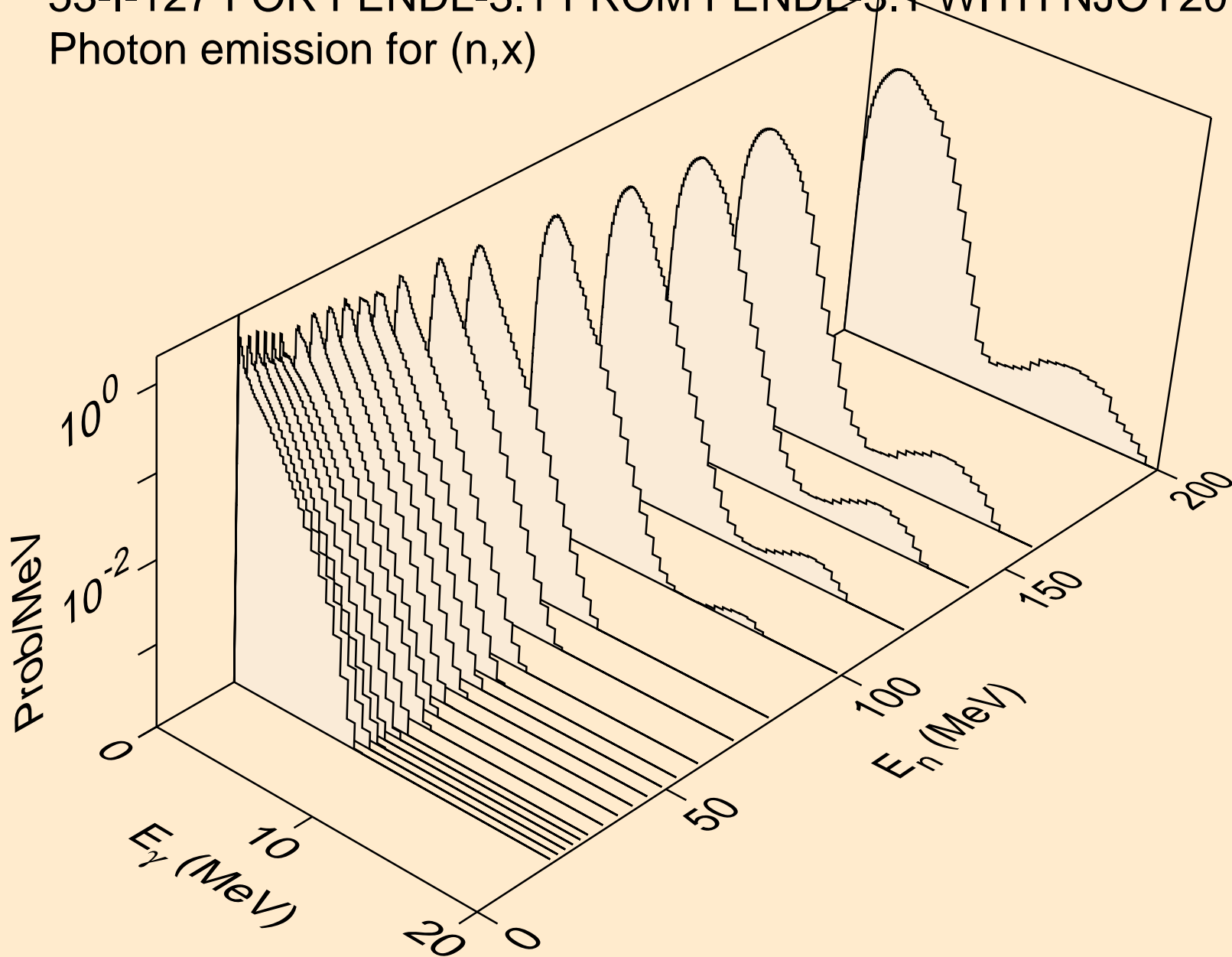

53-I-127 FOR FENDL-3.1 FROM FENDL-3.1 WITH NJOY2012.50+ C  
Photon emission for (n,2n)

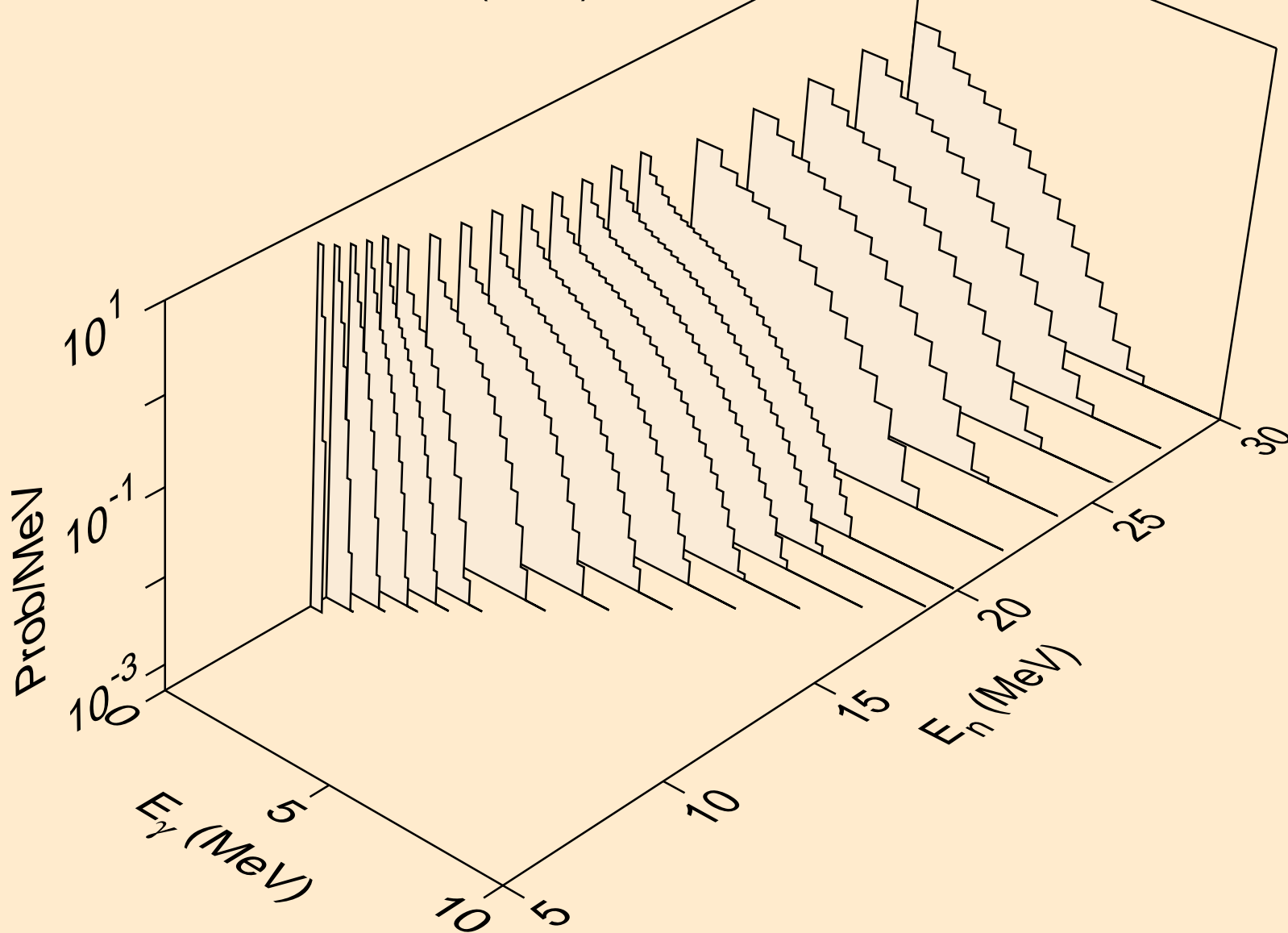

53-I-127 FOR FENDL-3.1 FROM FENDL-3.1 WITH NJOY2012.50+ C  
Photon emission for (n,3n)

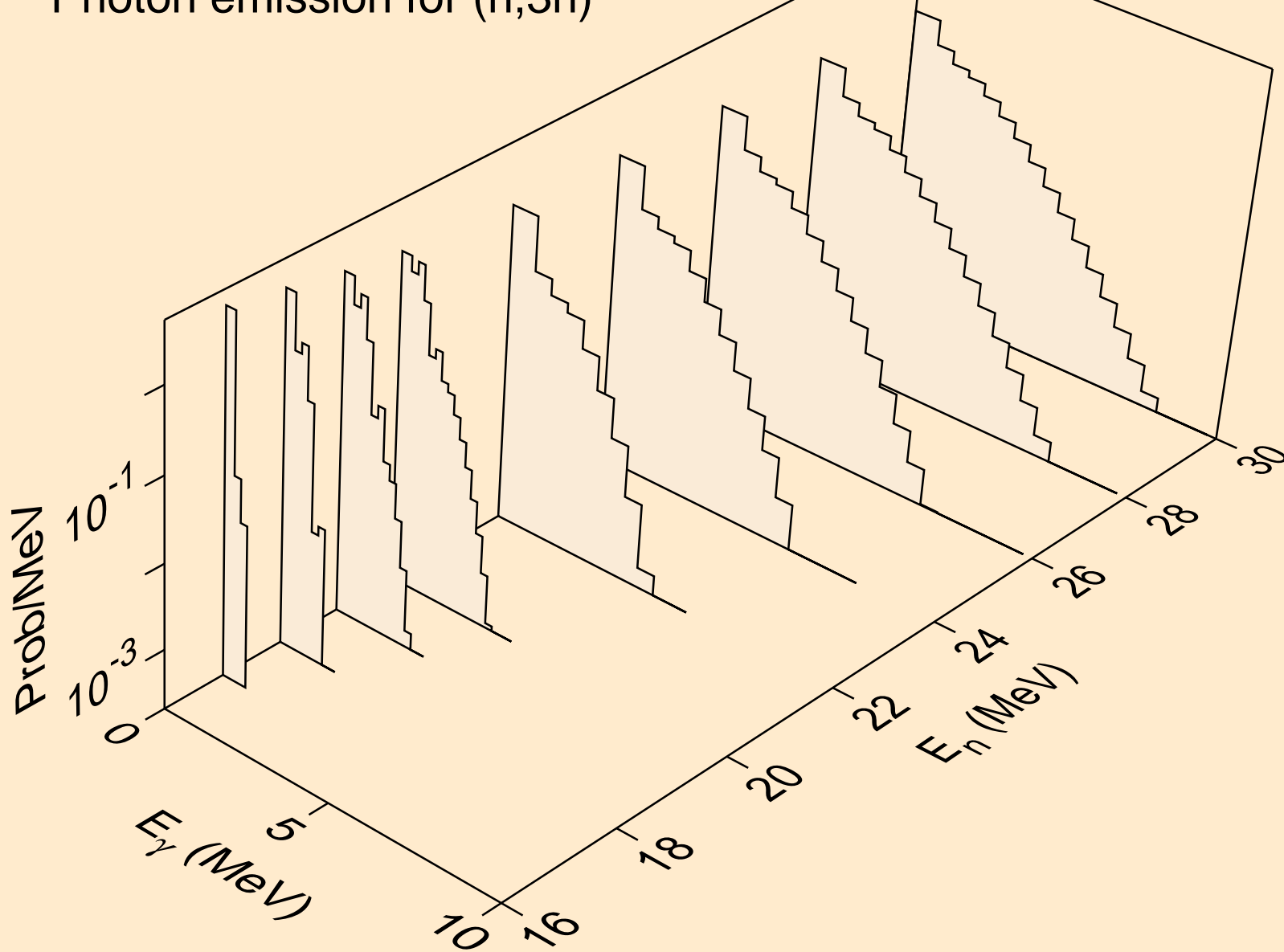

53-I-127 FOR FENDL-3.1 FROM FENDL-3.1 WITH NJOY2012.50+ C  
Photon emission for (n,n\*)a

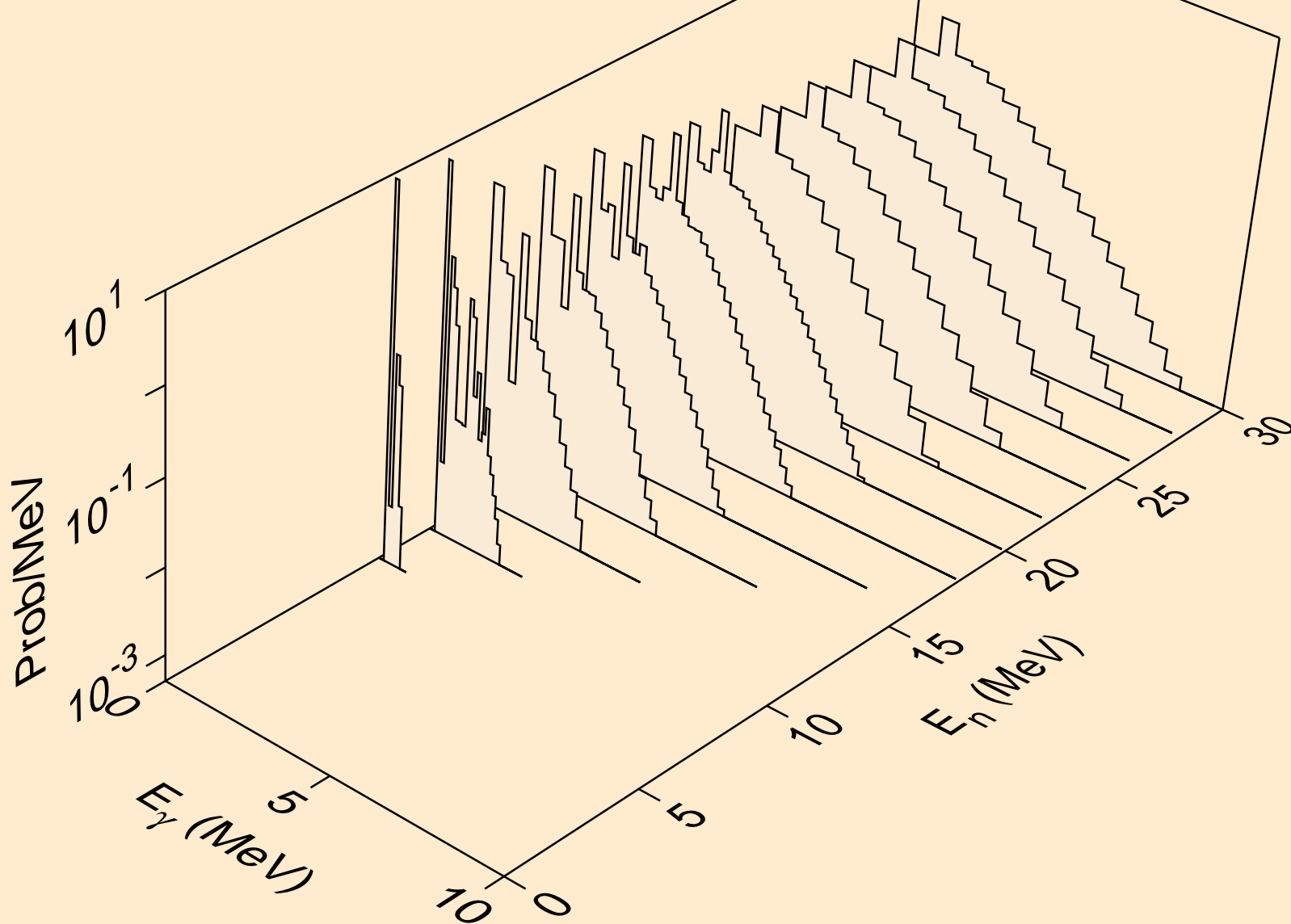

53-I-127 FOR FENDL-3.1 FROM FENDL-3.1 WITH NJOY2012.50+ C  
Photon emission for (n,n\*)p

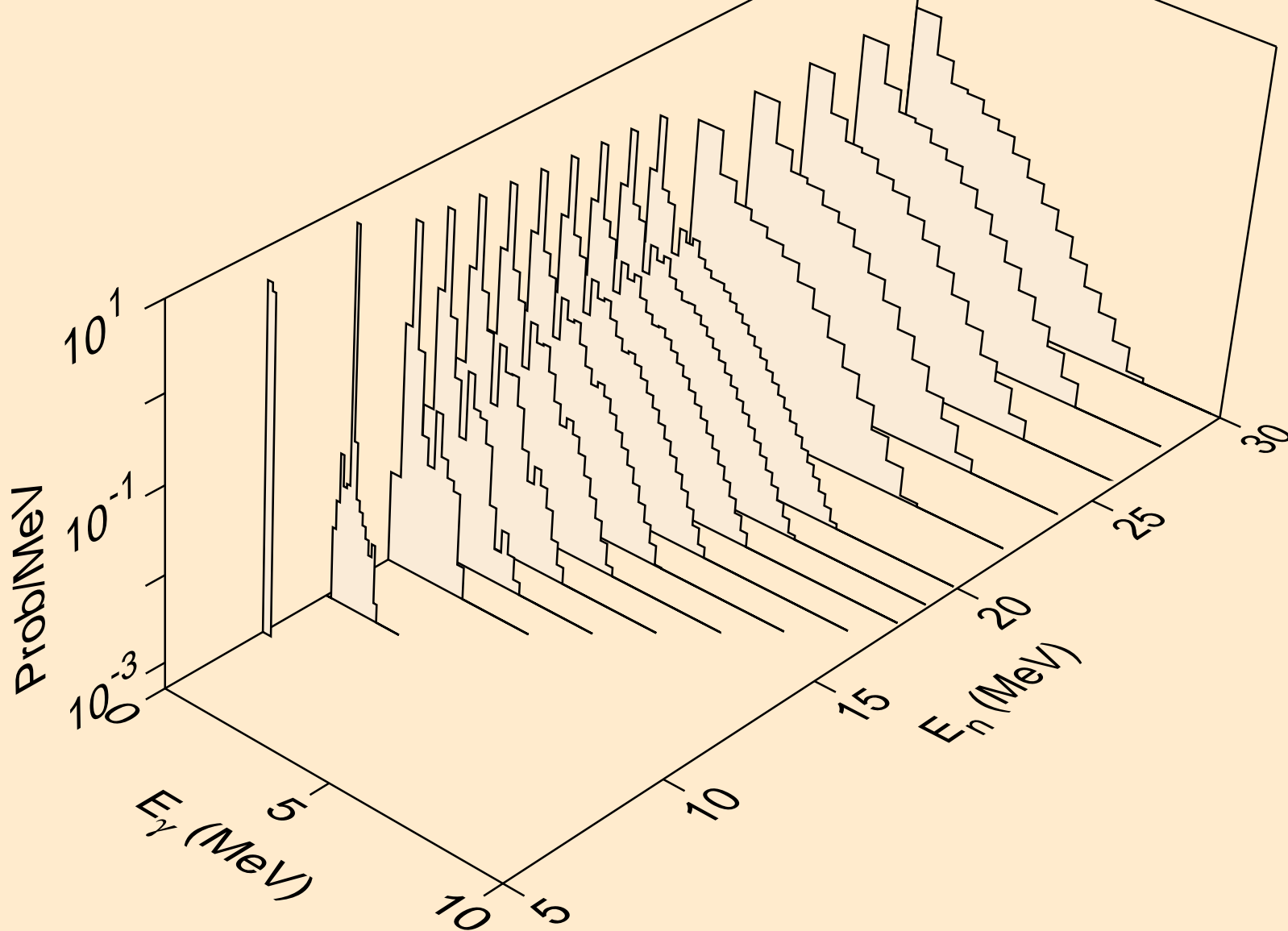



53-I-127 FOR FENDL-3.1 FROM FENDL-3.1 WITH NJOY2012.50+ C  
Photon emission for (n,4n)

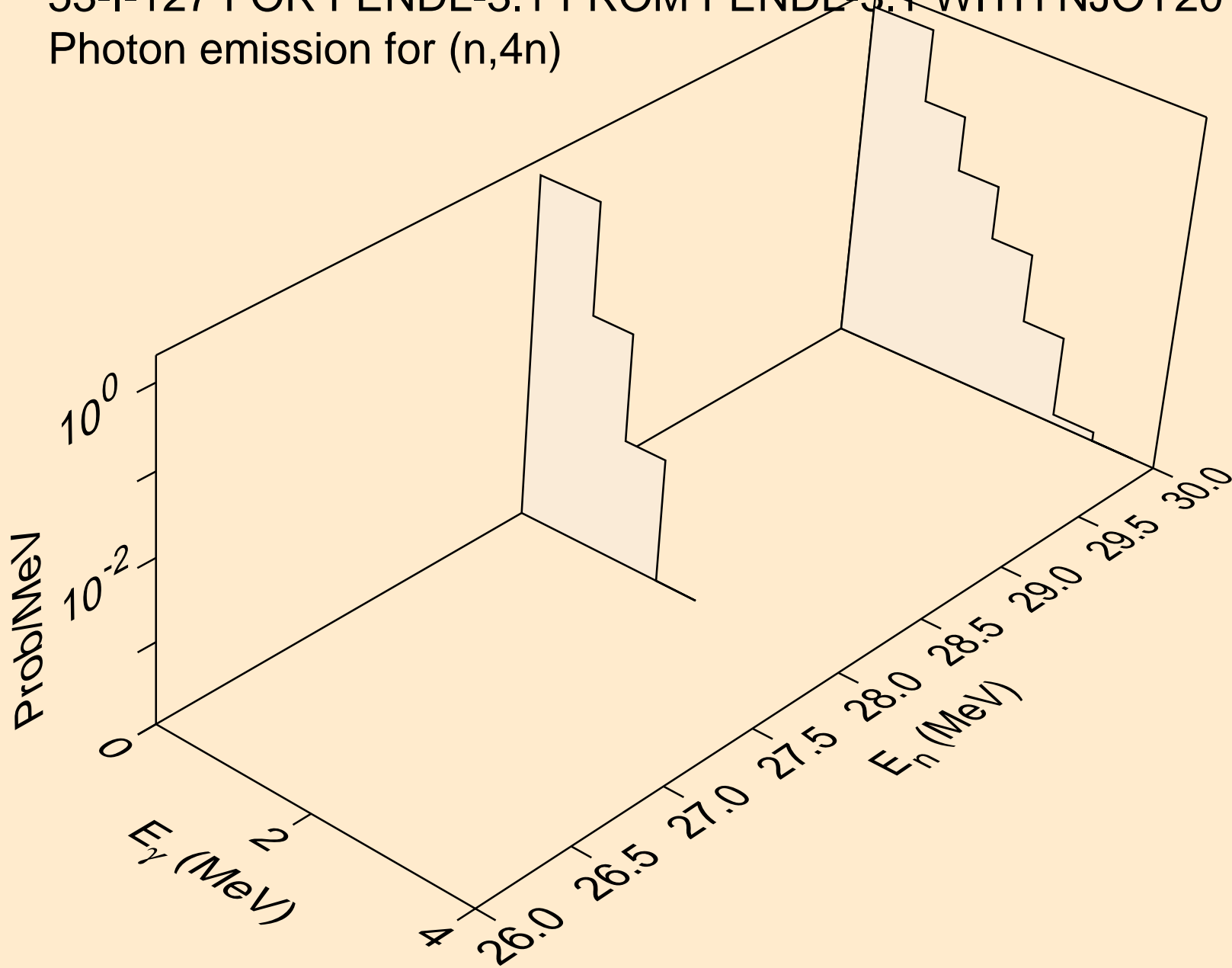

53-I-127 FOR FENDL-3.1 FROM FENDL-3.1 WITH NJOY2012.50+ C  
Photon emission for (n,n\*1)

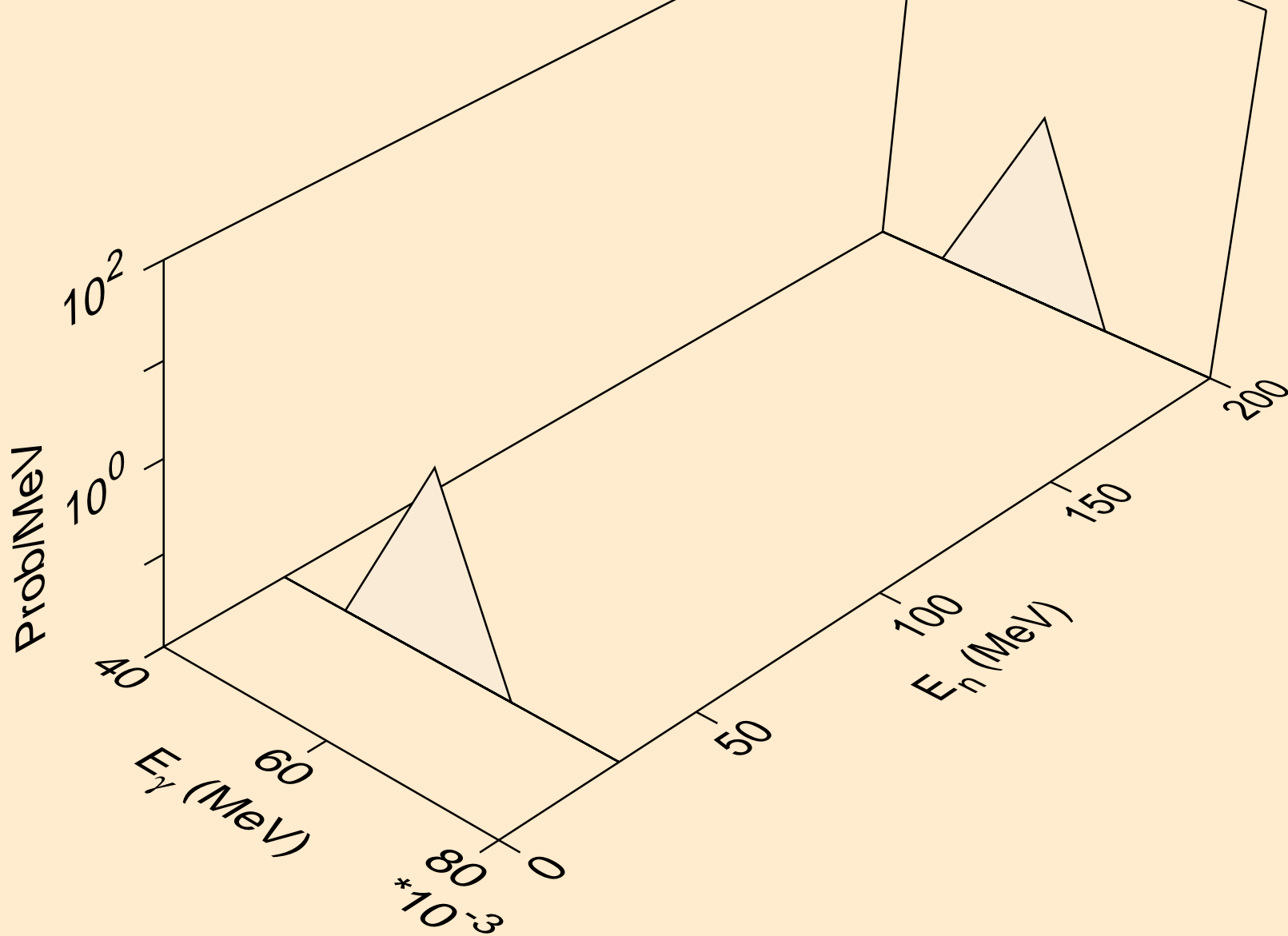

53-I-127 FOR FENDL-3.1 FROM FENDL-3.1 WITH NJOY2012.50+ C  
Photon emission for (n,n\*2)

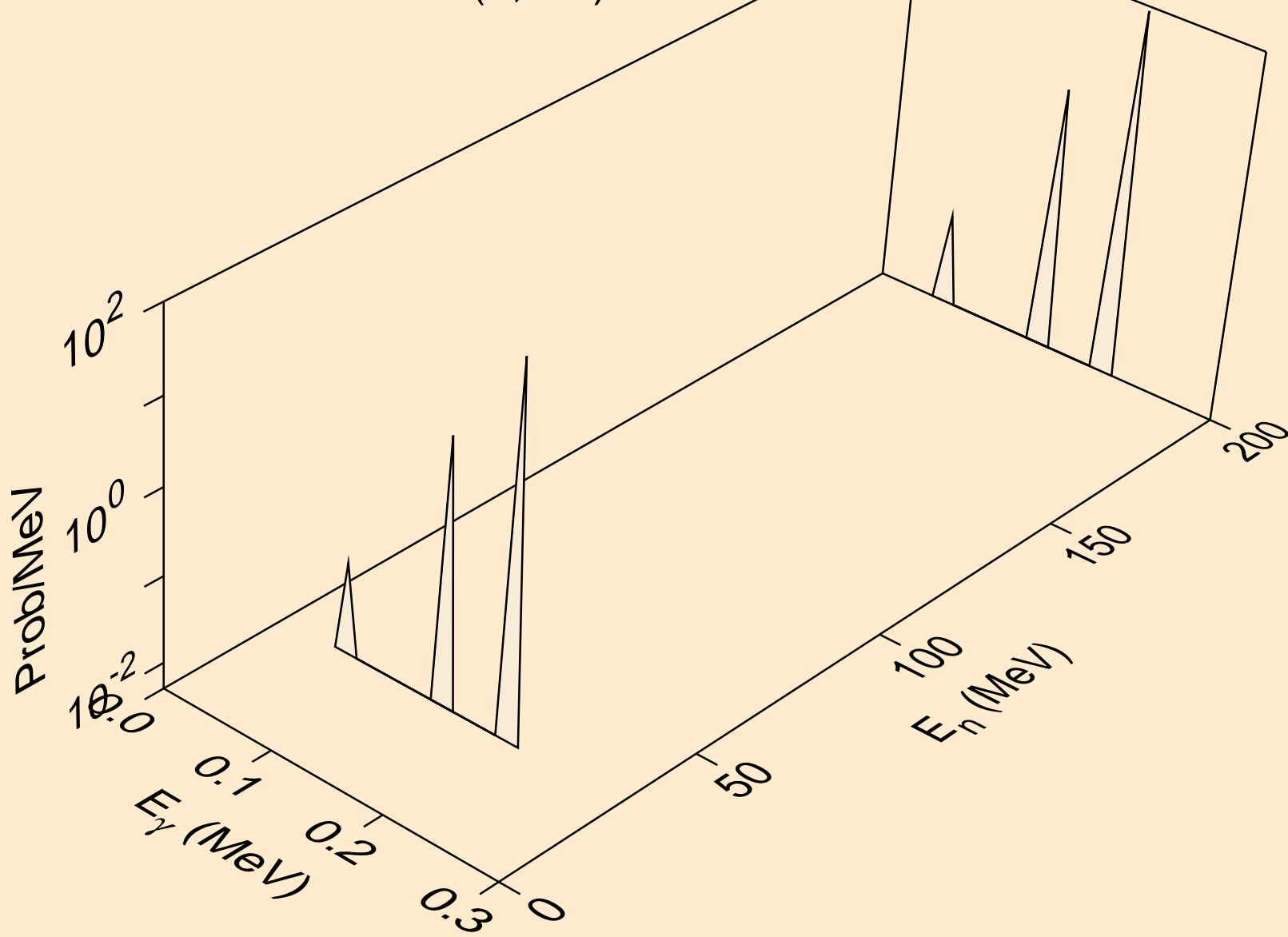

53-I-127 FOR FENDL-3.1 FROM FENDL-3.1 WITH NJOY2012.50+ C  
Photon emission for (n,n\*3)

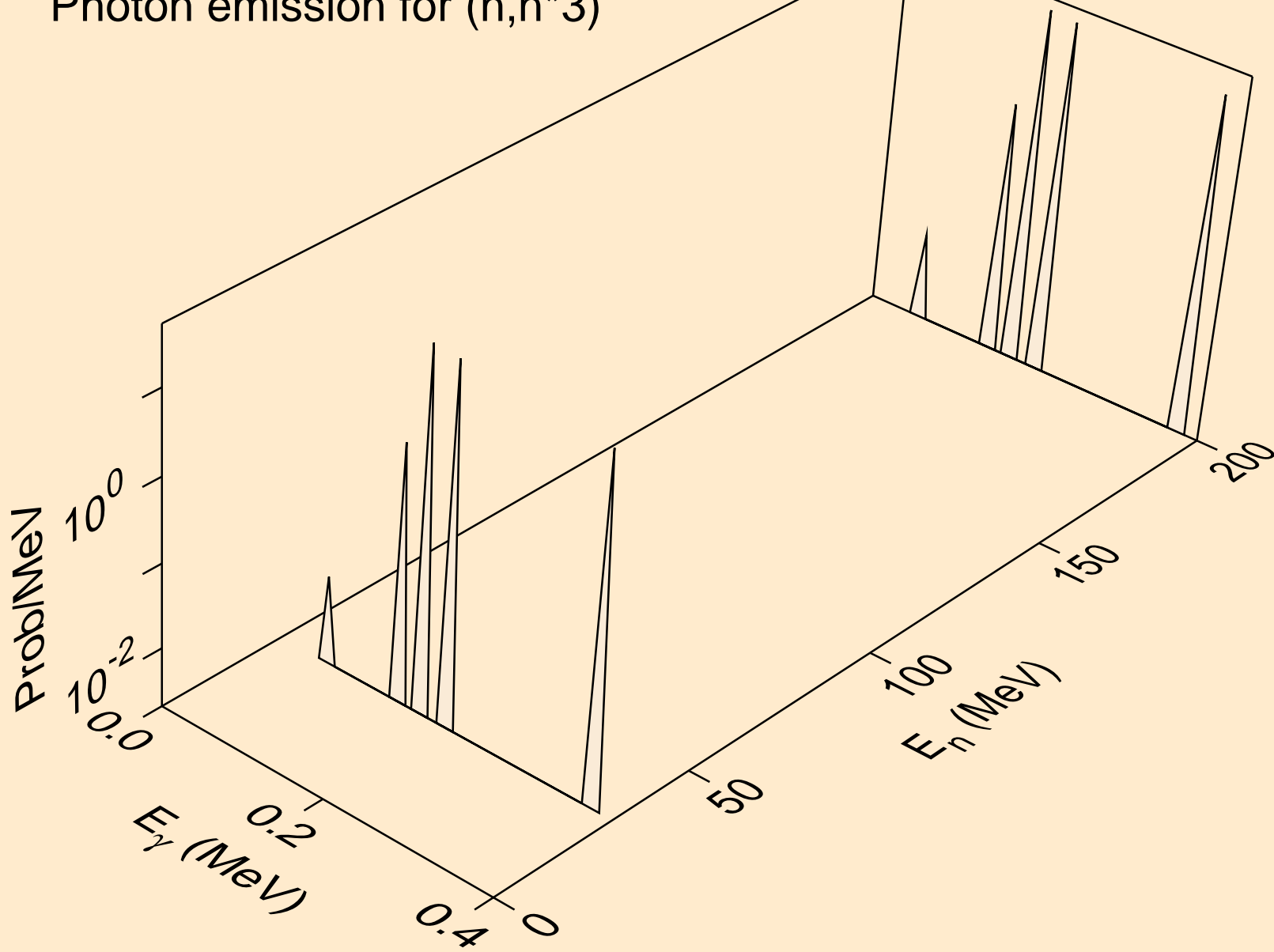

53-I-127 FOR FENDL-3.1 FROM FENDL-3.1 WITH NJOY2012.50+ C  
Photon emission for (n,n\*4)

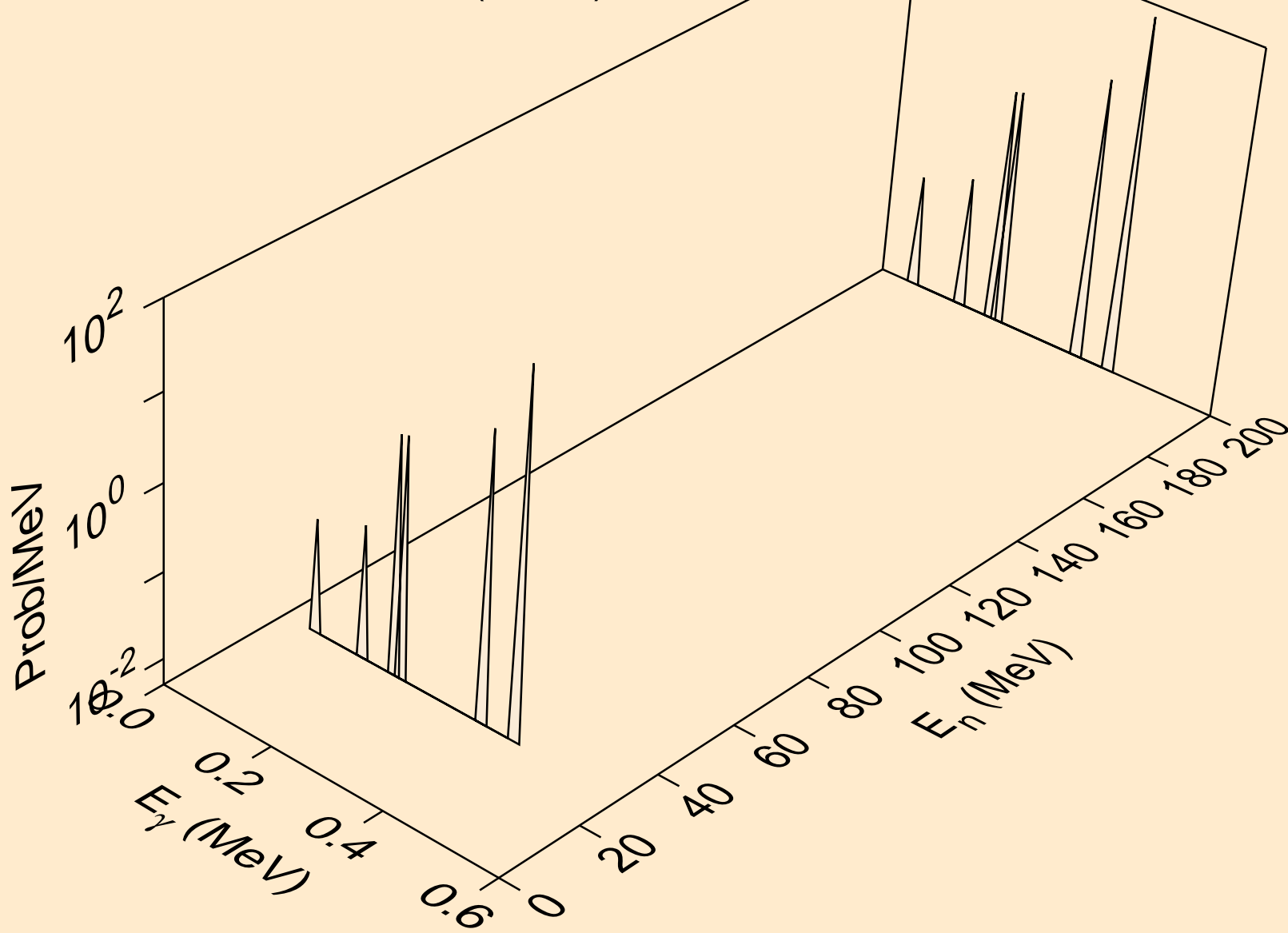

53-I-127 FOR FENDL-3.1 FROM FENDL-3.1 WITH NJOY2012.50+ C  
Photon emission for (n,n\*5)

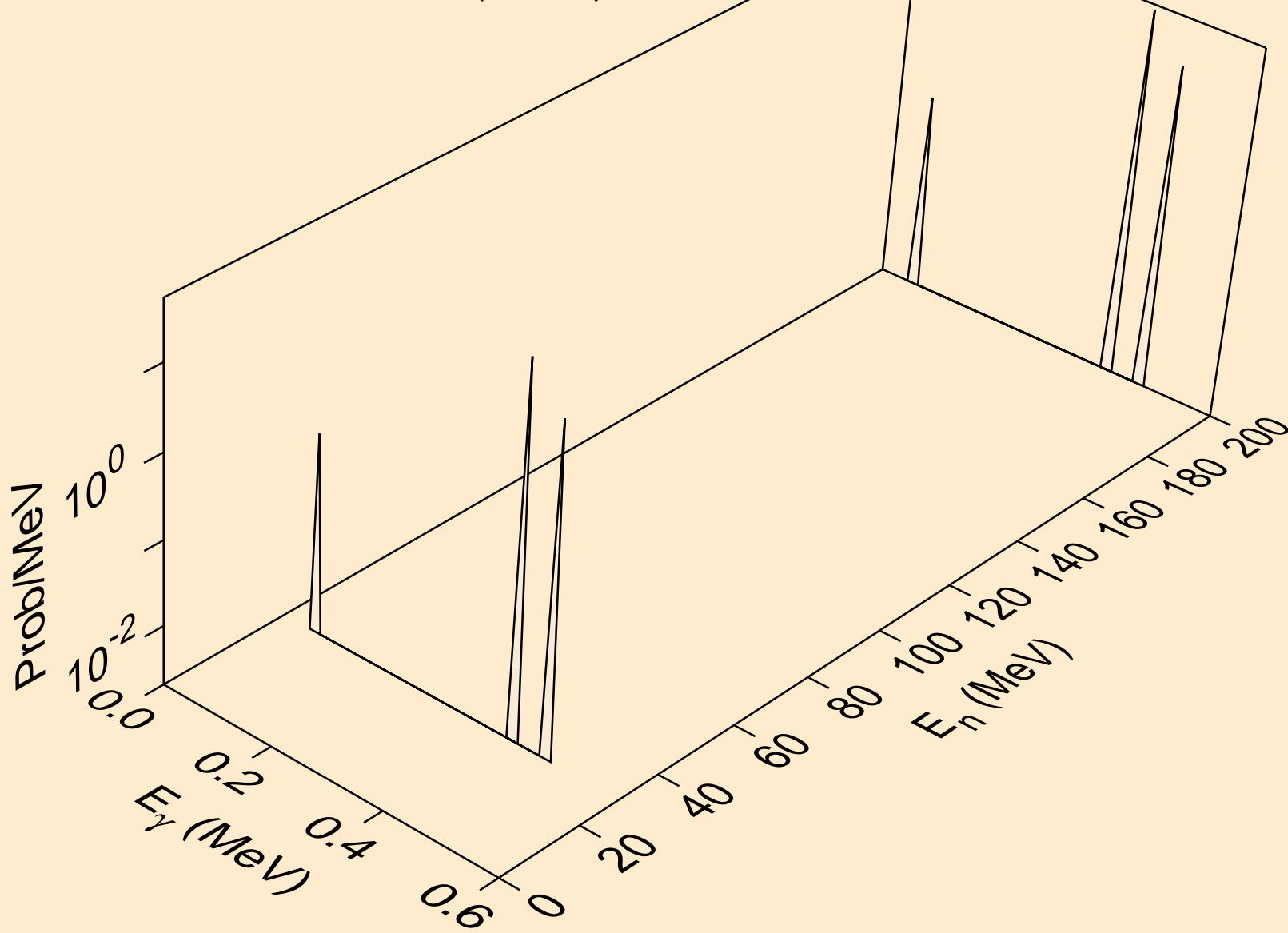

53-I-127 FOR FENDL-3.1 FROM FENDL-3.1 WITH NJOY2012.50+ C  
Photon emission for (n,n\*6)

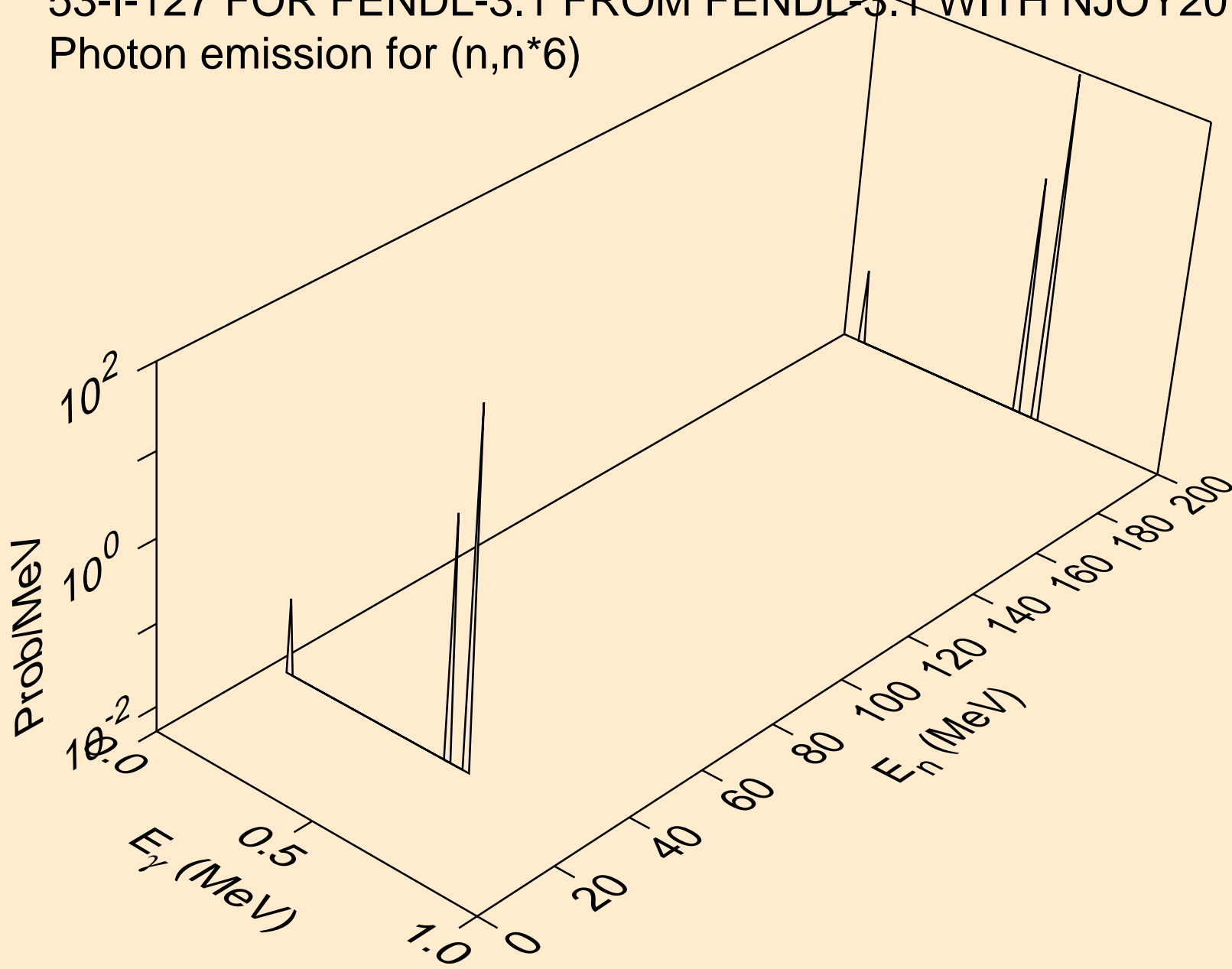

53-I-127 FOR FENDL-3.1 FROM FENDL-3.1 WITH NJOY2012.50+ C  
Photon emission for (n,n\*7)

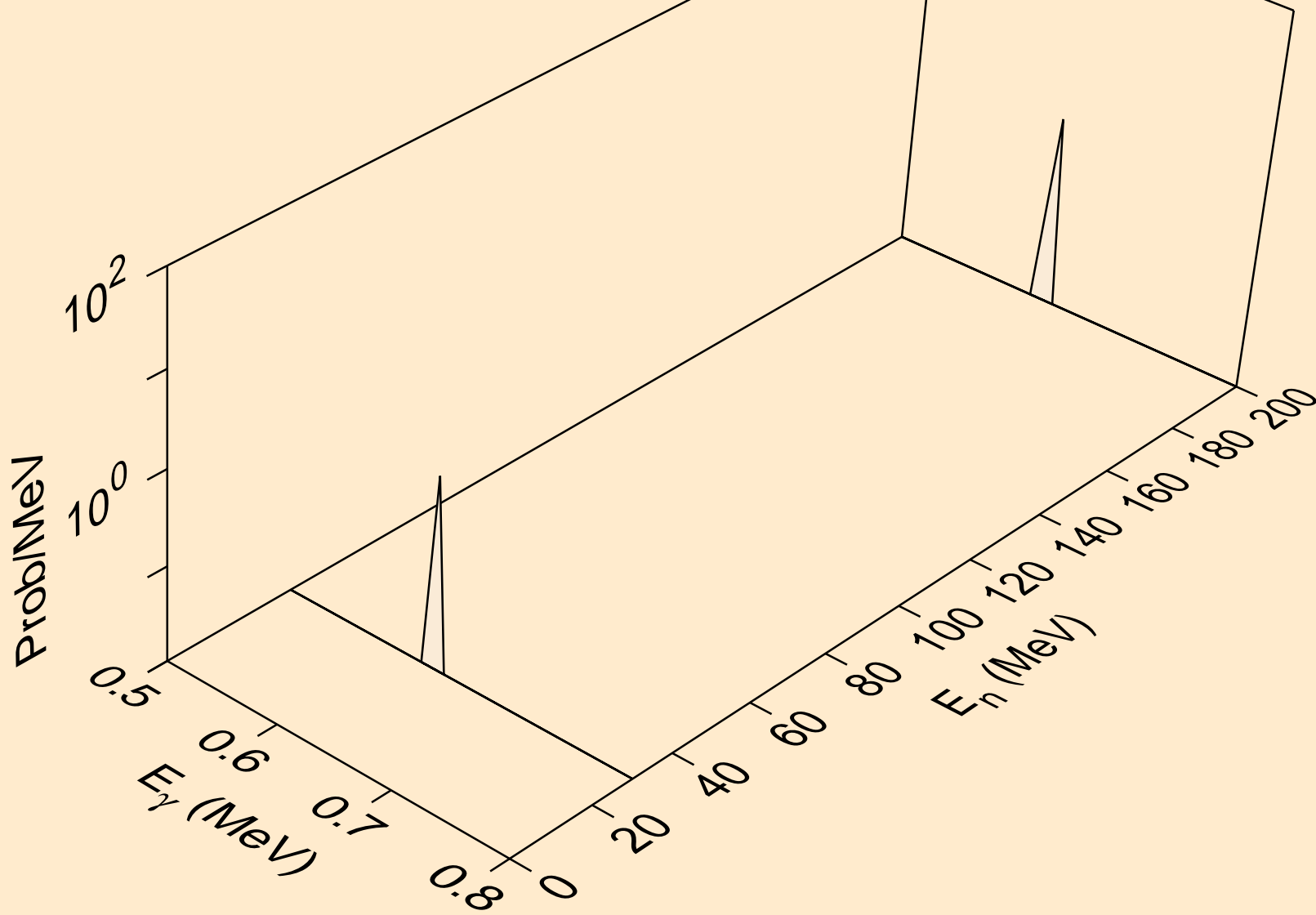



53-I-127 FOR FENDL-3.1 FROM FENDL-3.1 WITH NJOY2012.50+ C  
Photon emission for (n,n\*8)

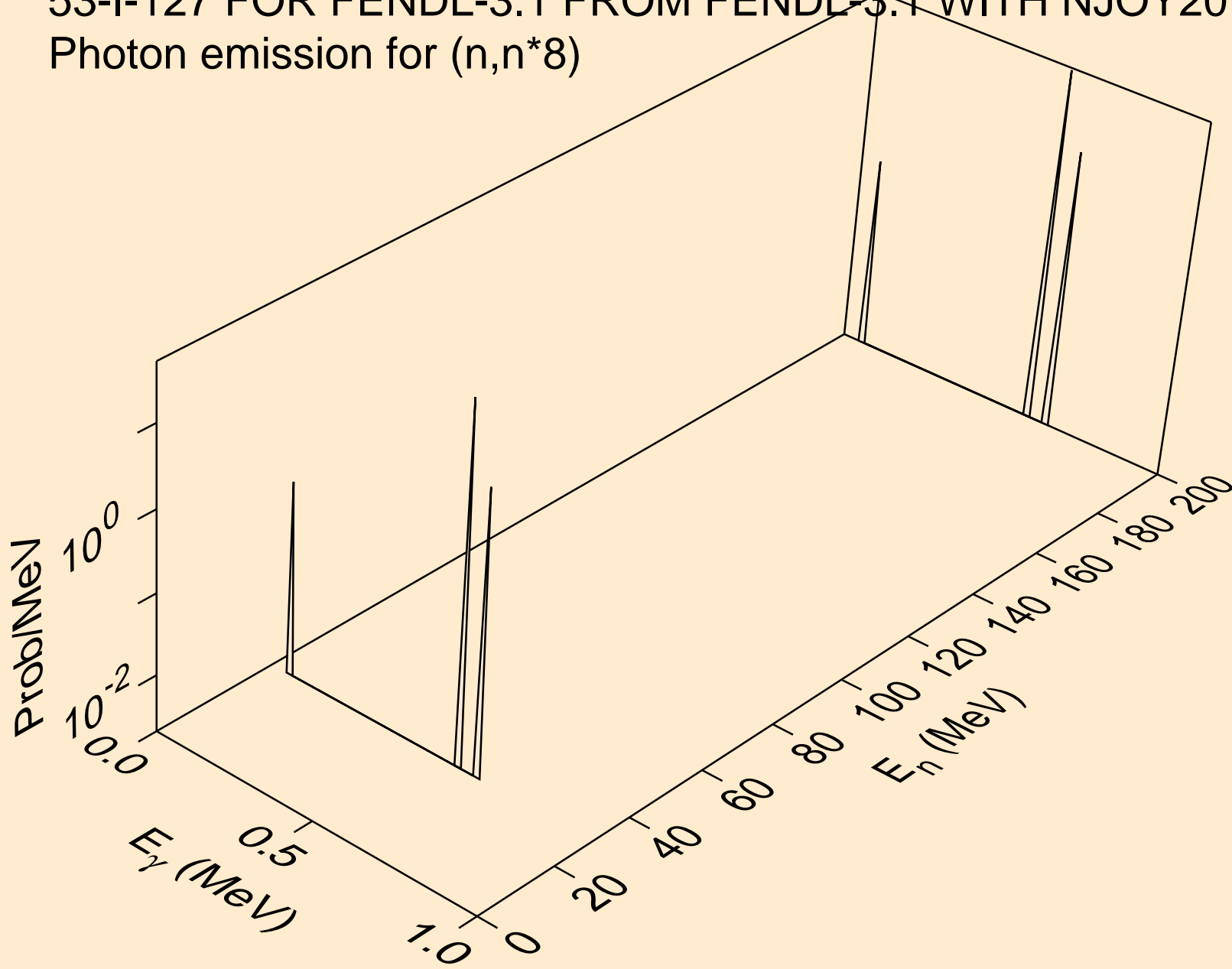

53-I-127 FOR FENDL-3.1 FROM FENDL-3.1 WITH NJOY2012.50+ C  
Photon emission for (n,n\*9)

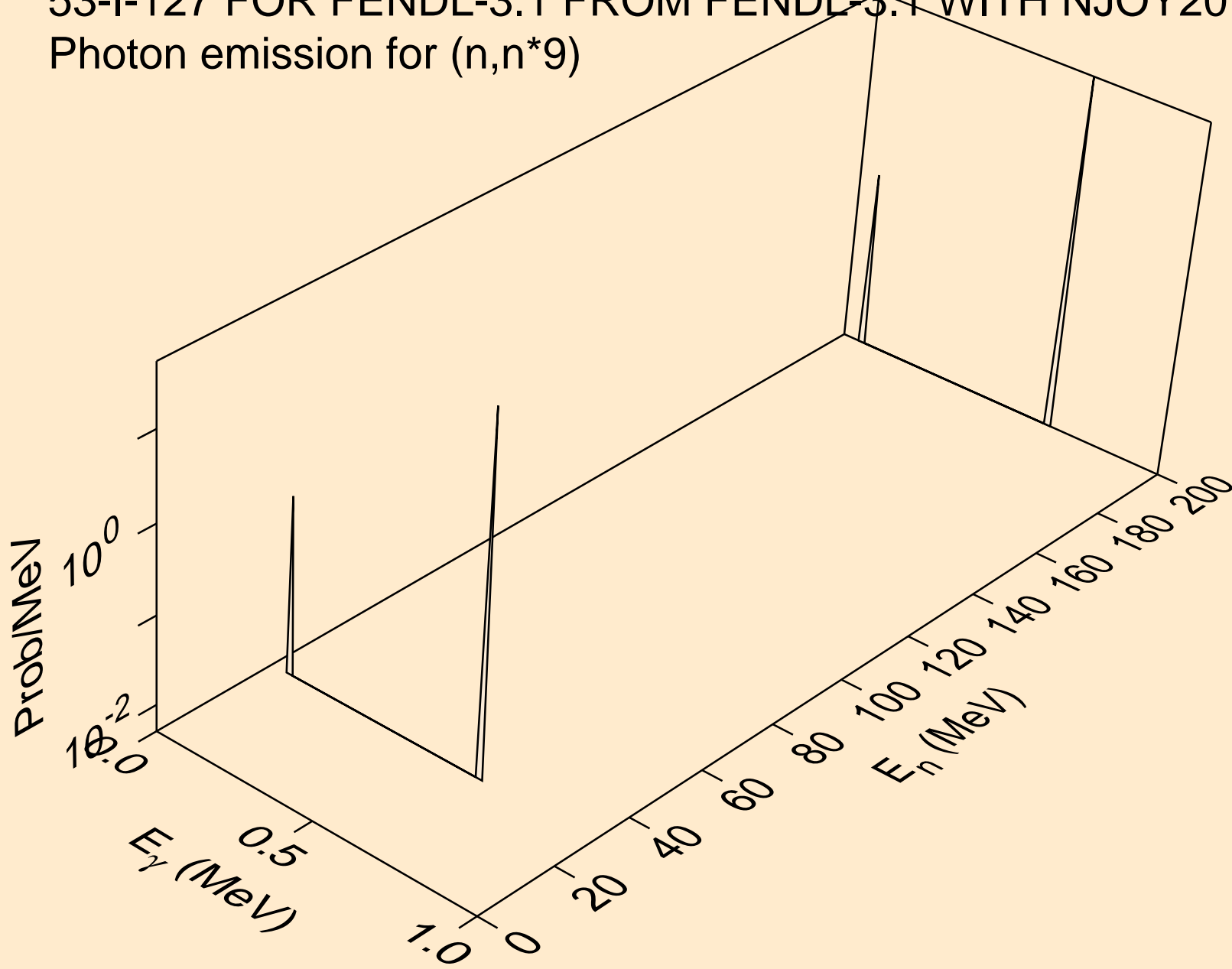

53-I-127 FOR FENDL-3.1 FROM FENDL-3.1 WITH NJOY2012.50+ C  
Photon emission for (n,n\*10)

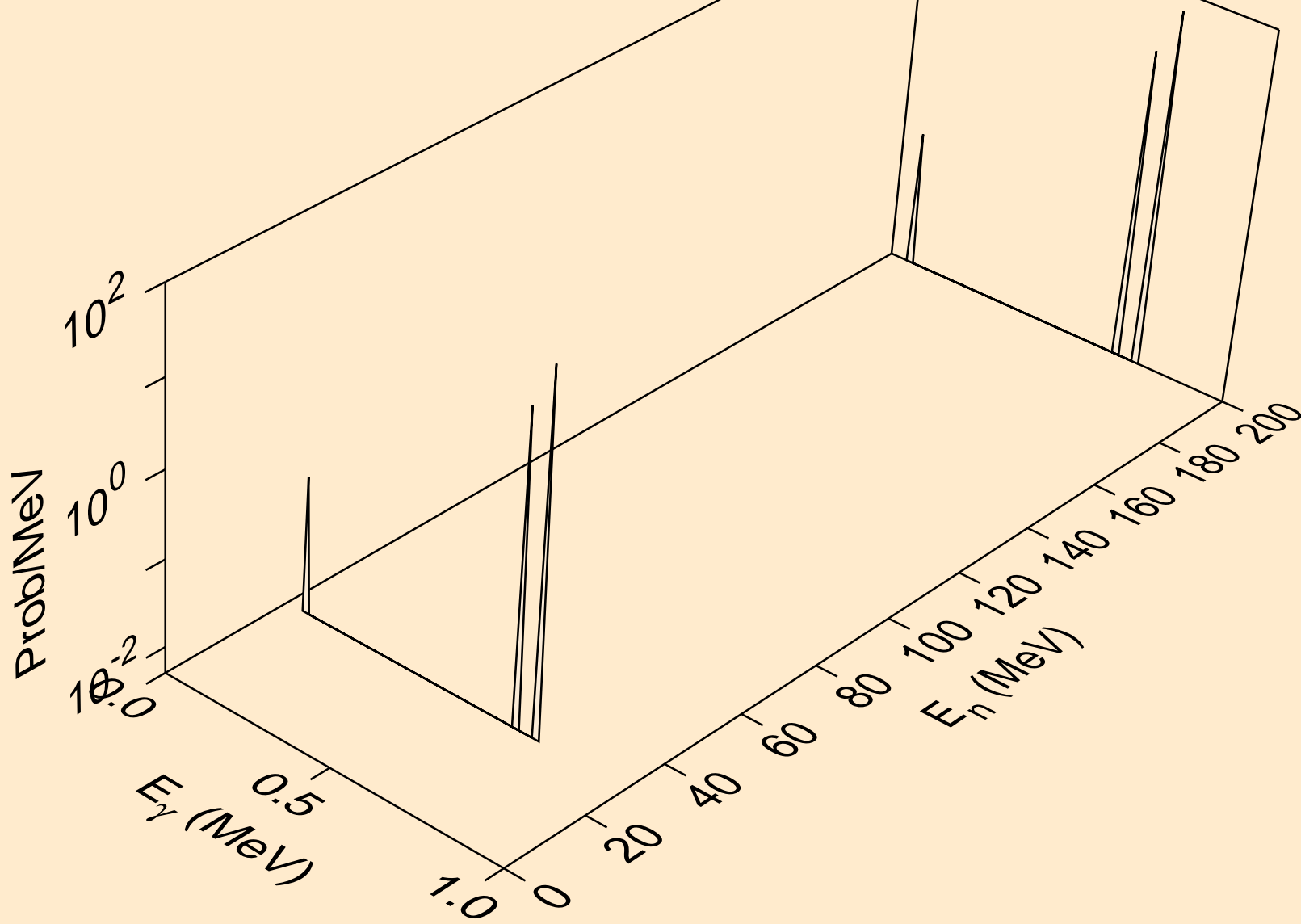

53-I-127 FOR FENDL-3.1 FROM FENDL-3.1 WITH NJOY2012.50+ C  
Photon emission for (n,n\*11)

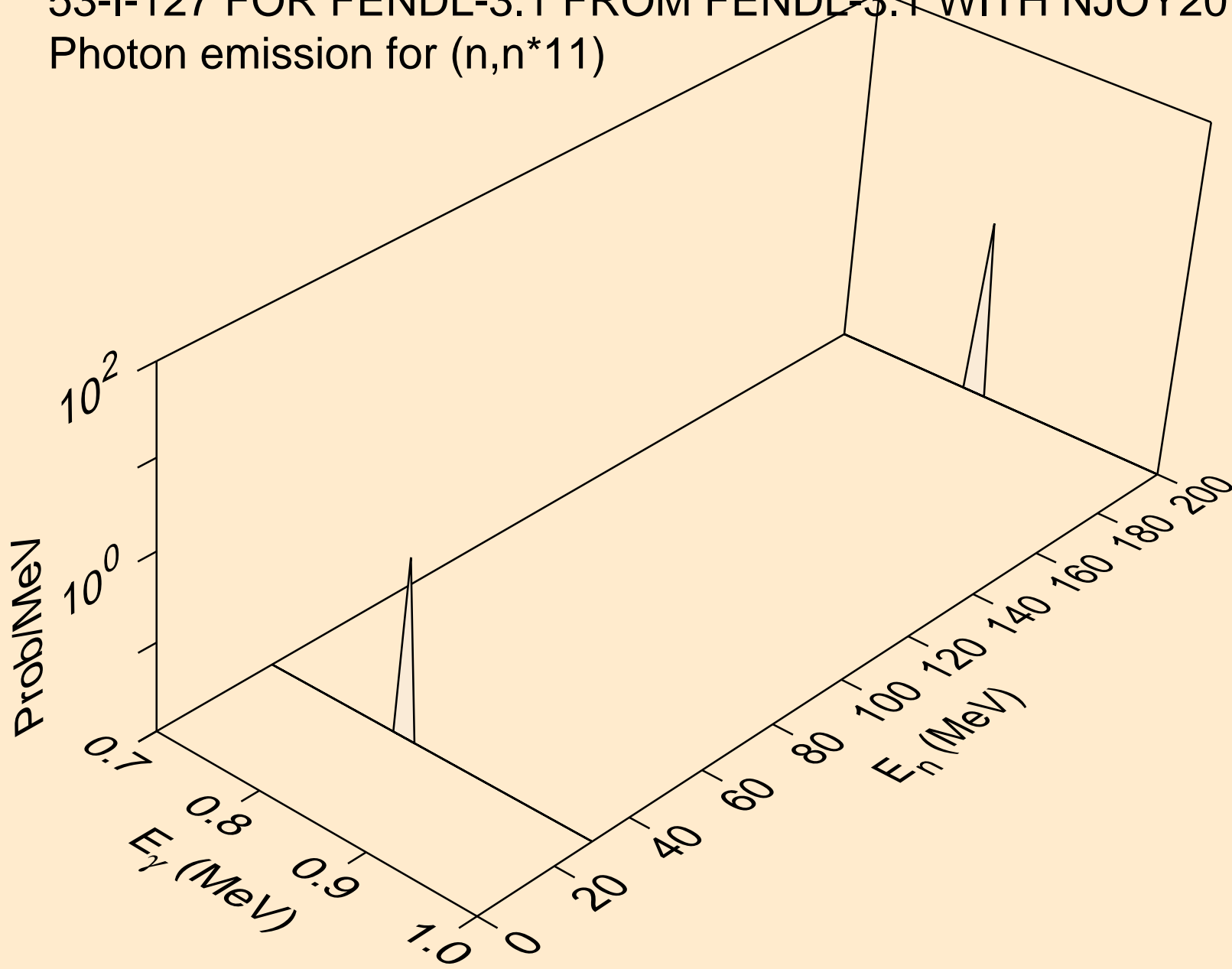

53-I-127 FOR FENDL-3.1 FROM FENDL-3.1 WITH NJOY2012.50+ C  
Photon emission for (n,n\*12)

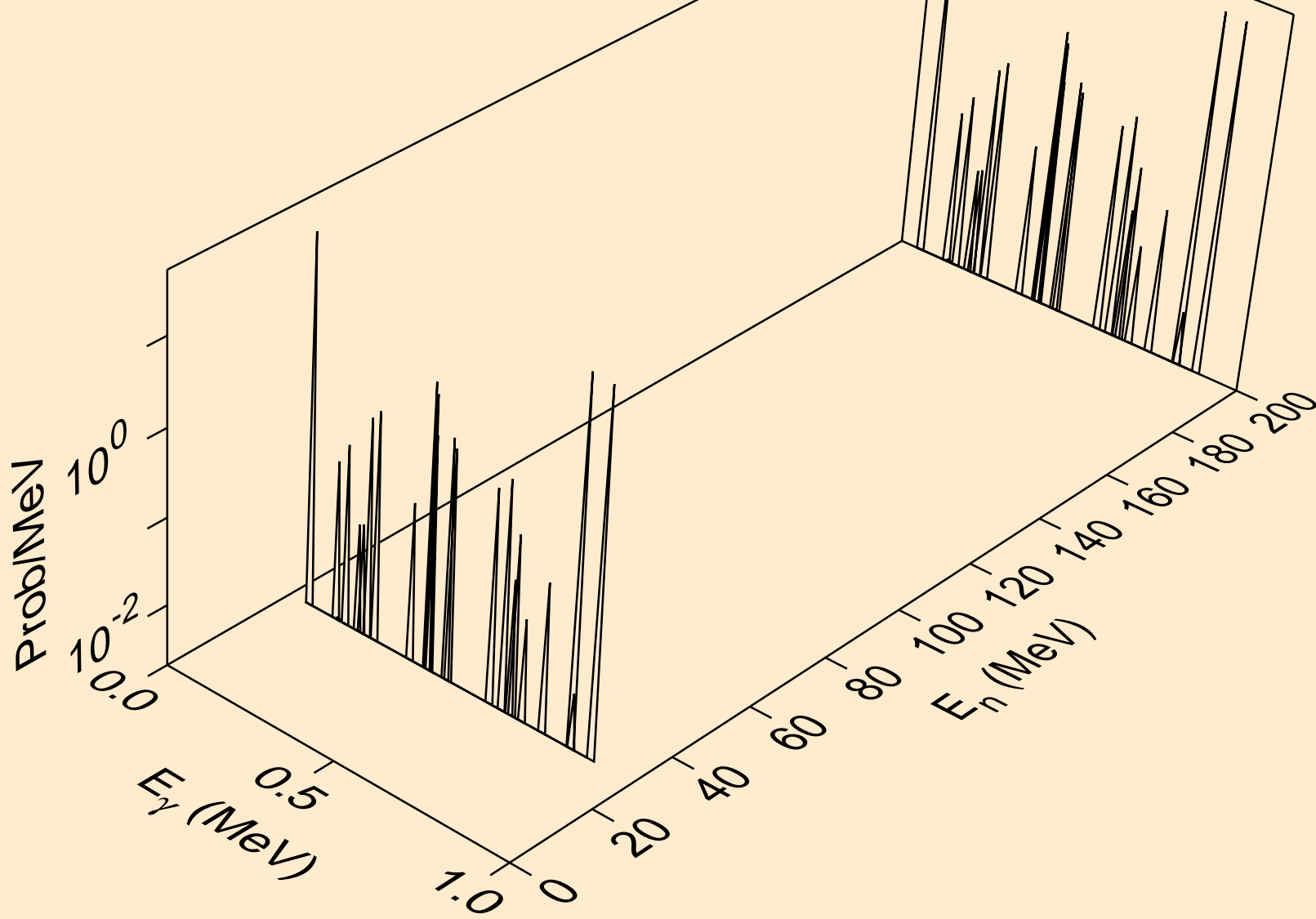

53-I-127 FOR FENDL-3.1 FROM FENDL-3.1 WITH NJOY2012.50+ C  
Photon emission for (n,n\*13)

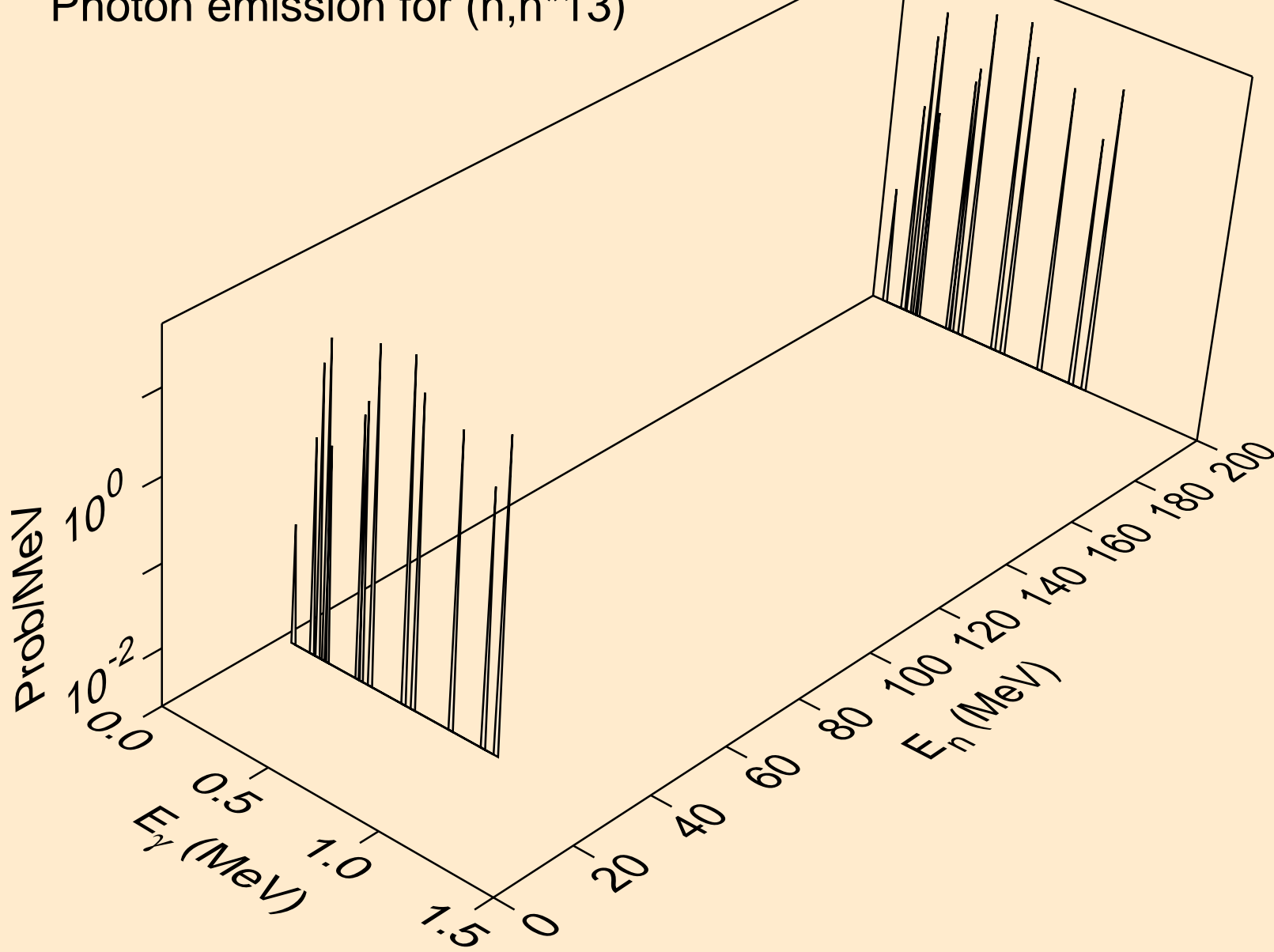

53-I-127 FOR FENDL-3.1 FROM FENDL-3.1 WITH NJOY2012.50+ C  
Photon emission for (n,n\*14)

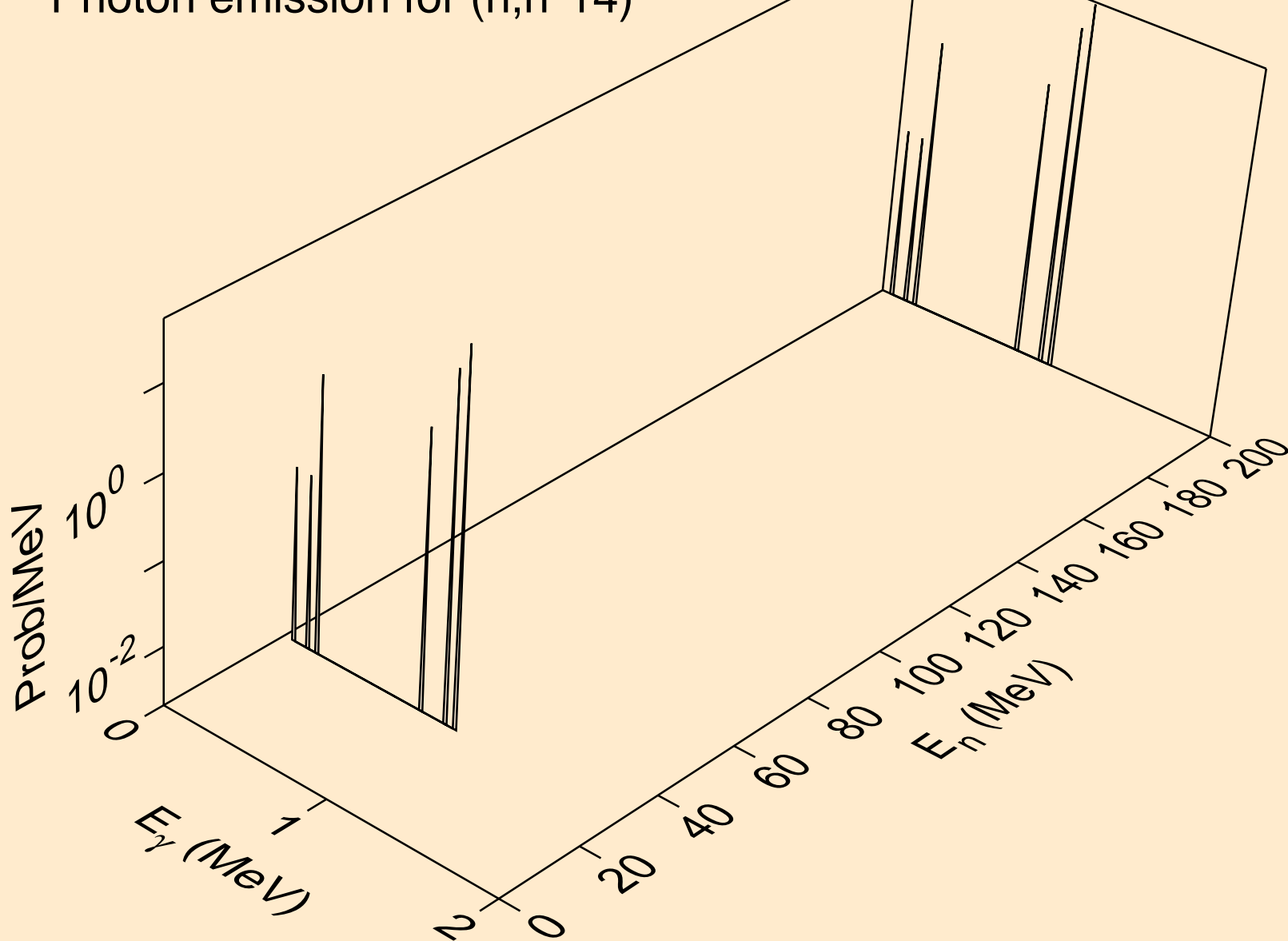

53-I-127 FOR FENDL-3.1 FROM FENDL-3.1 WITH NJOY2012.50+ C  
Photon emission for (n,n\*15)

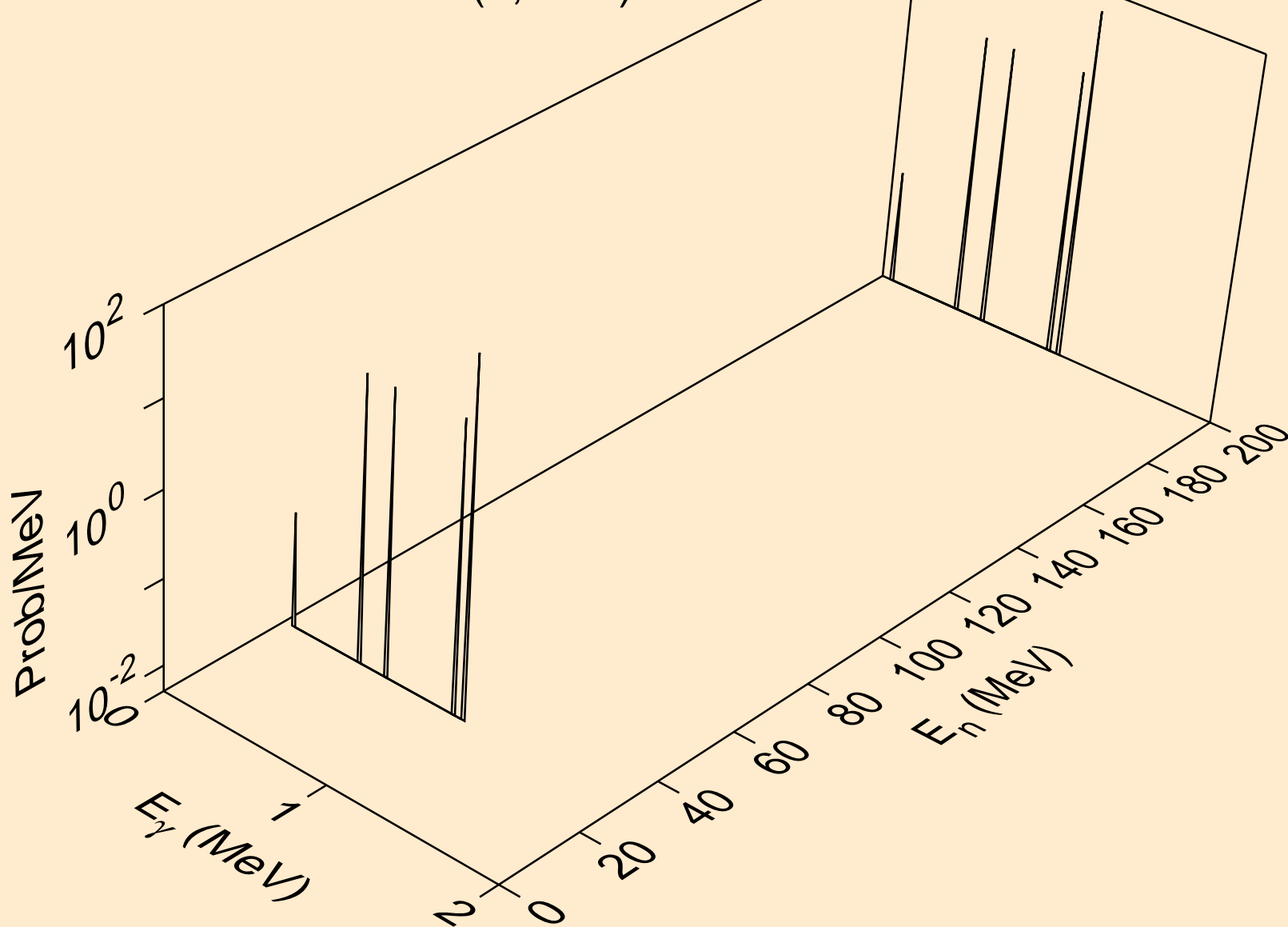



53-I-127 FOR FENDL-3.1 FROM FENDL-3.1 WITH NJOY2012.50+ C  
Photon emission for (n,n\*16)

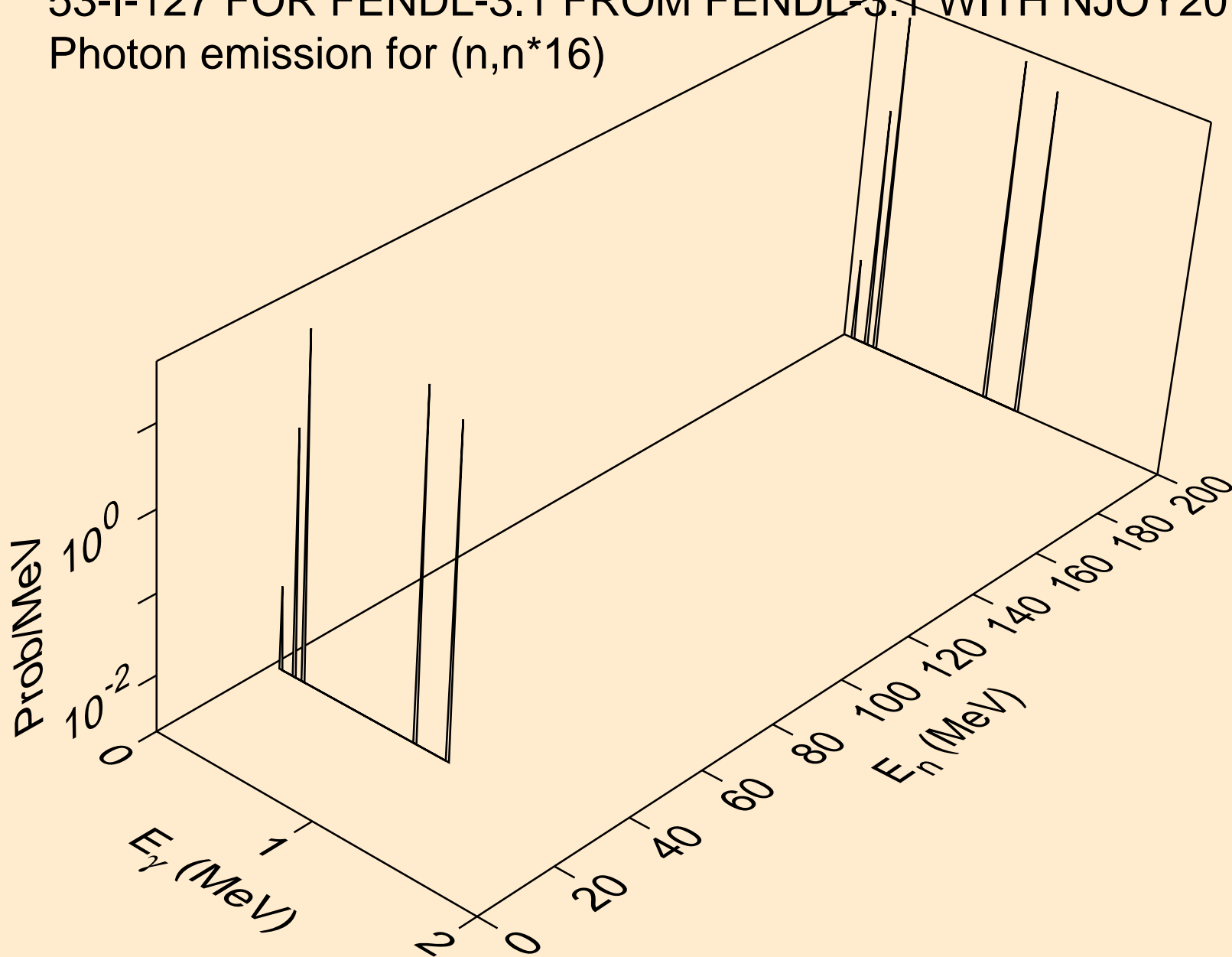

53-I-127 FOR FENDL-3.1 FROM FENDL-3.1 WITH NJOY2012.50+ C  
Photon emission for (n,n\*17)

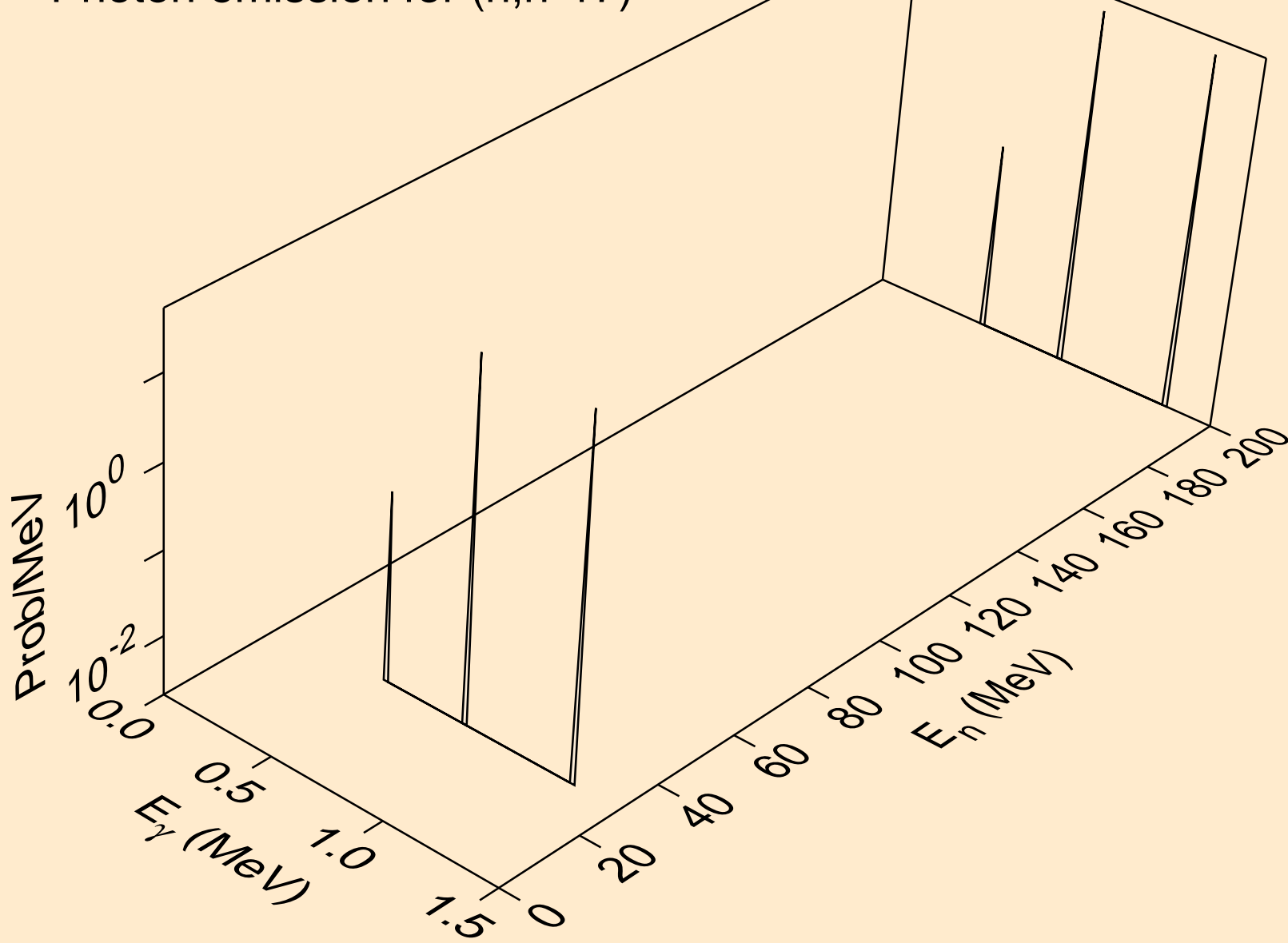

53-I-127 FOR FENDL-3.1 FROM FENDL-3.1 WITH NJOY2012.50+ C  
Photon emission for (n,n\*18)

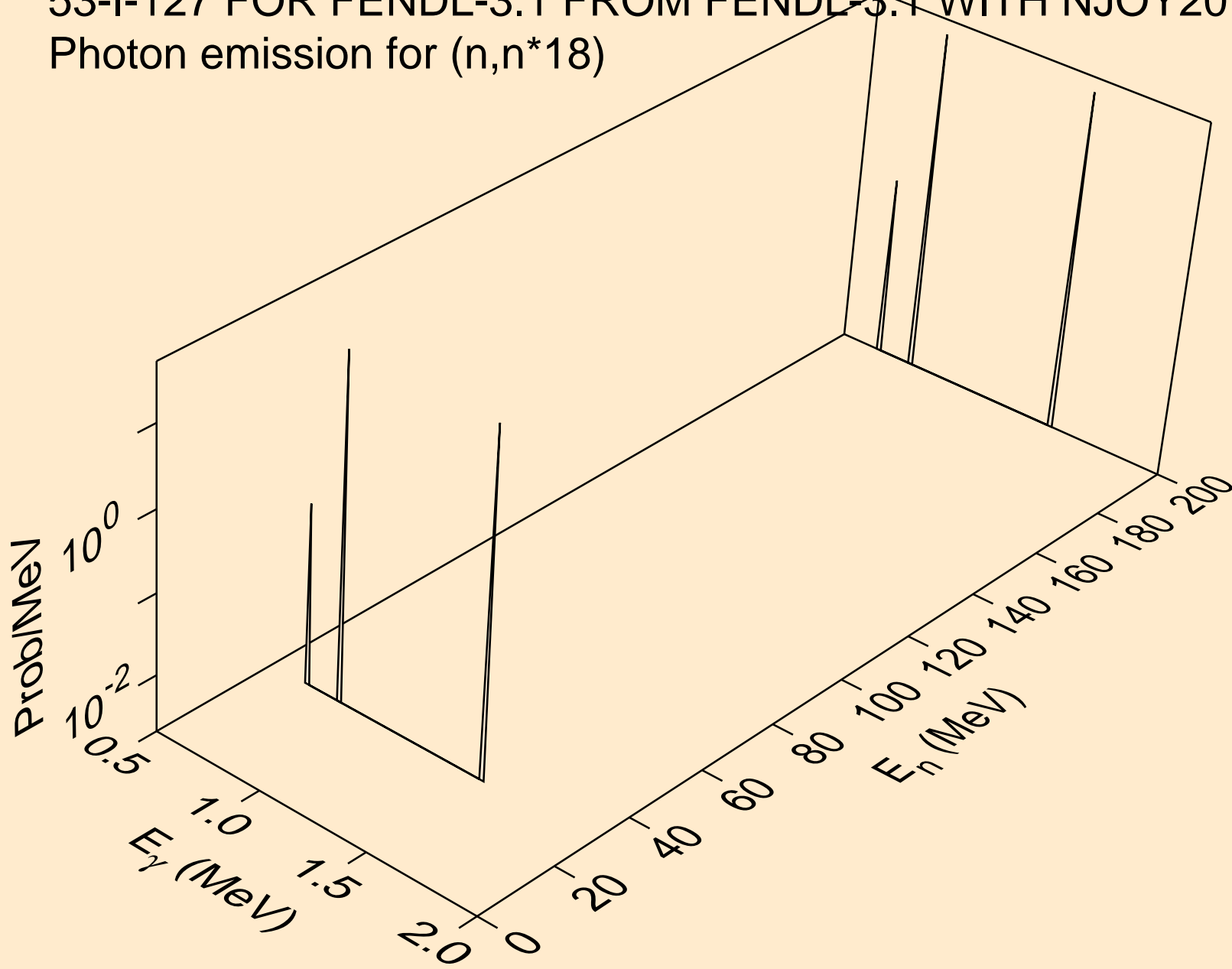

53-I-127 FOR FENDL-3.1 FROM FENDL-3.1 WITH NJOY2012.50+ C  
Photon emission for (n,n\*19)

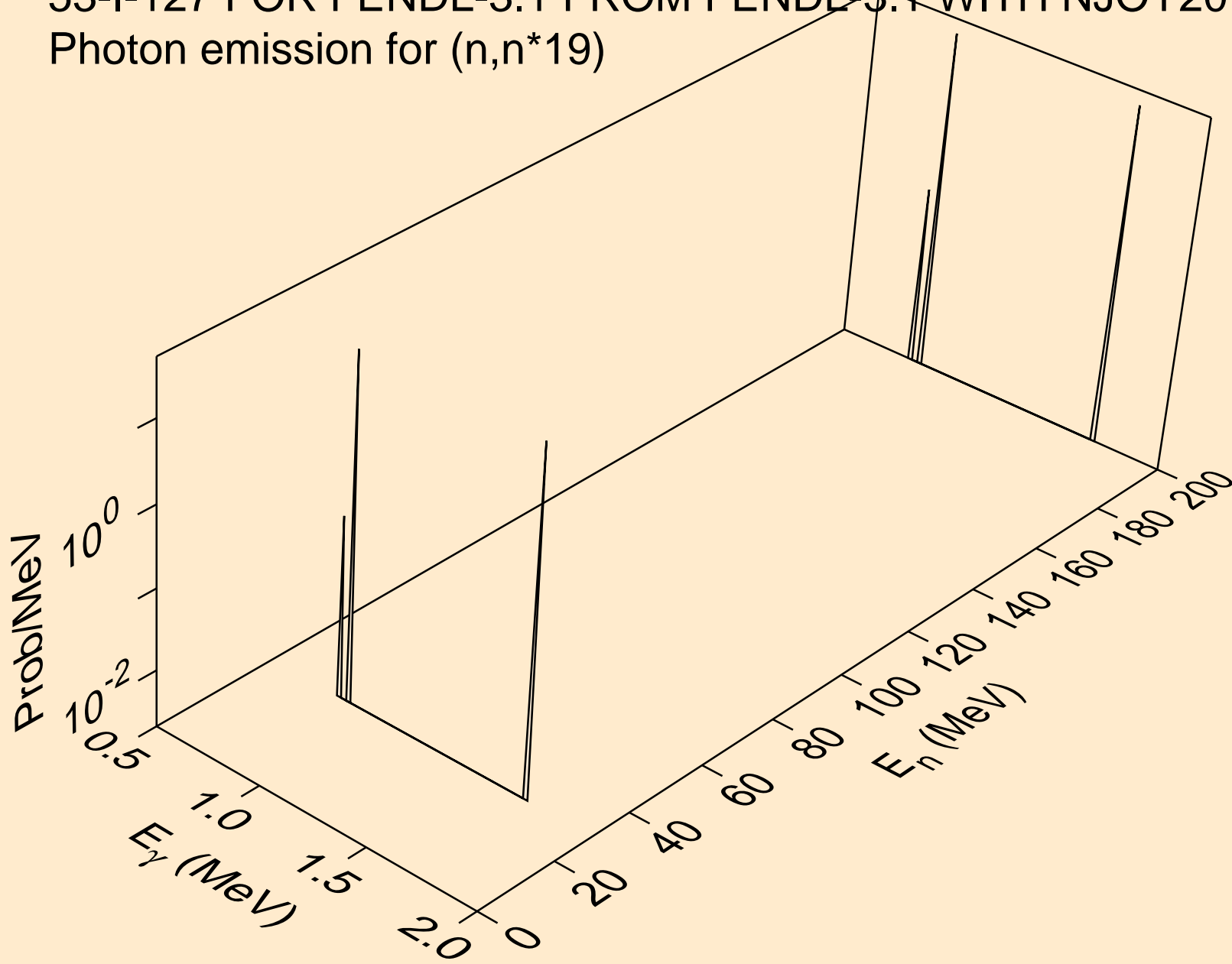

53-I-127 FOR FENDL-3.1 FROM FENDL-3.1 WITH NJOY2012.50+ C  
Photon emission for (n,n\*20)

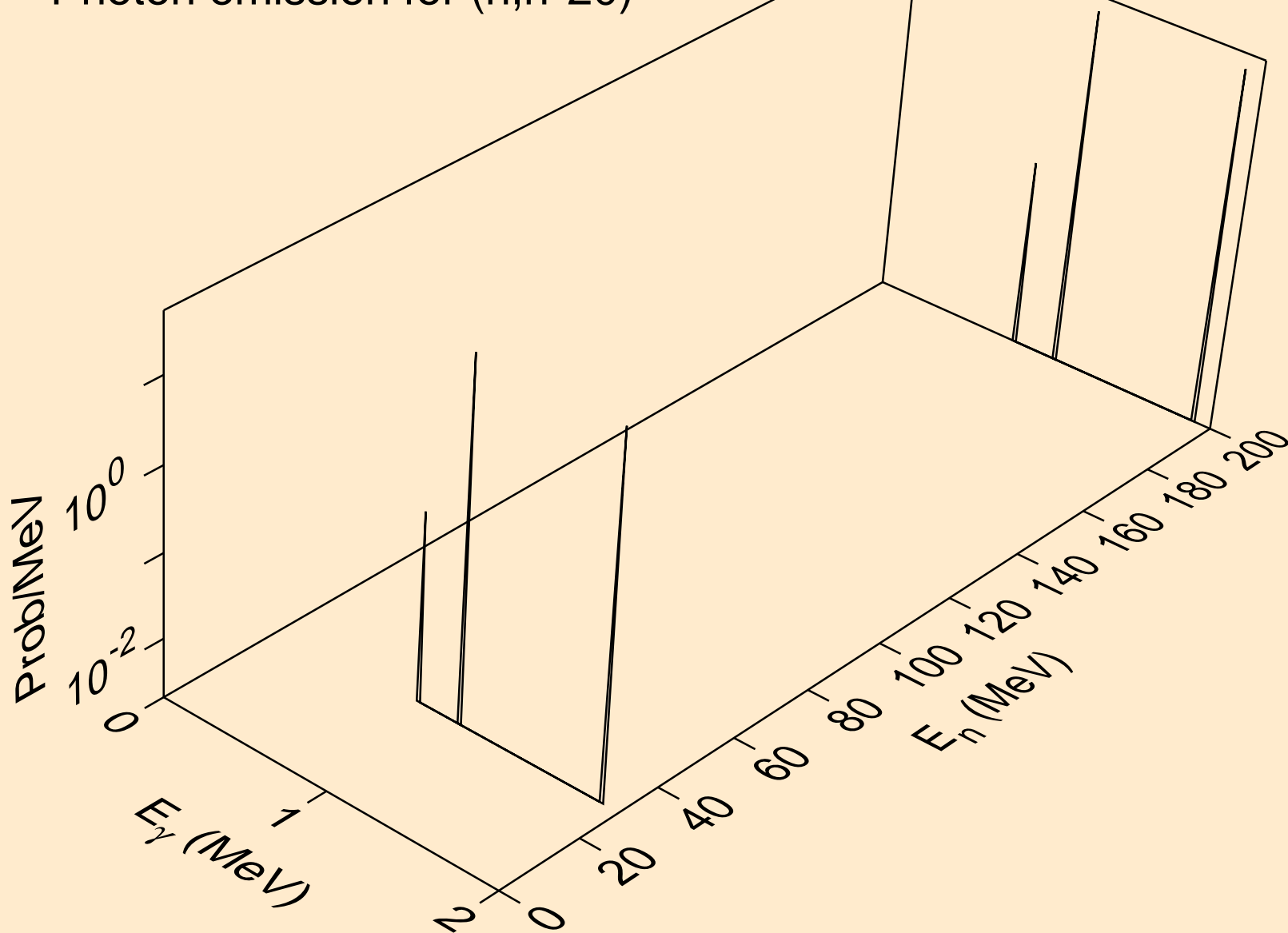

53-I-127 FOR FENDL-3.1 FROM FENDL-3.1 WITH NJOY2012.50+ C  
Photon emission for (n,n\*21)

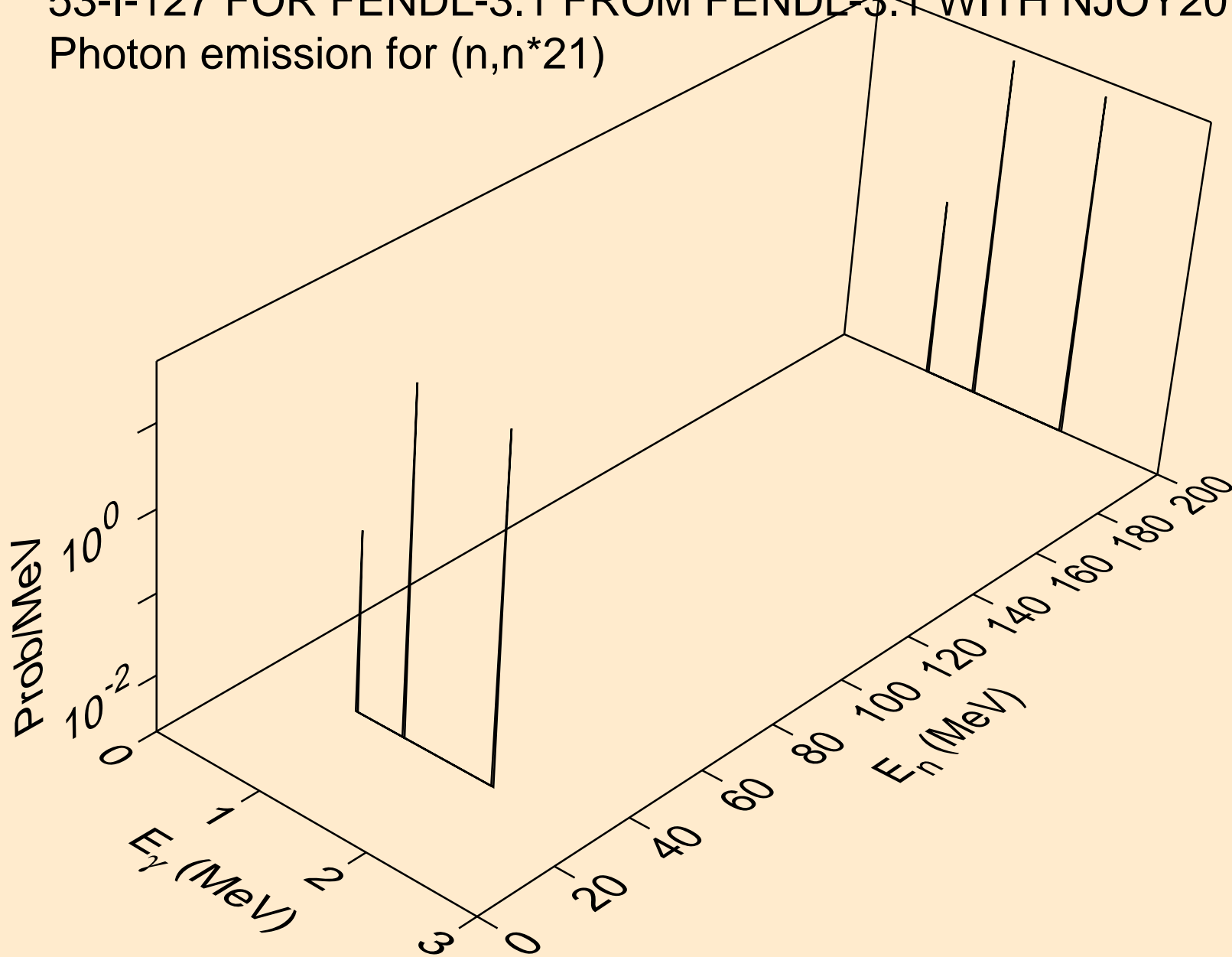

53-I-127 FOR FENDL-3.1 FROM FENDL-3.1 WITH NJOY2012.50+ C  
Photon emission for (n,n\*c)

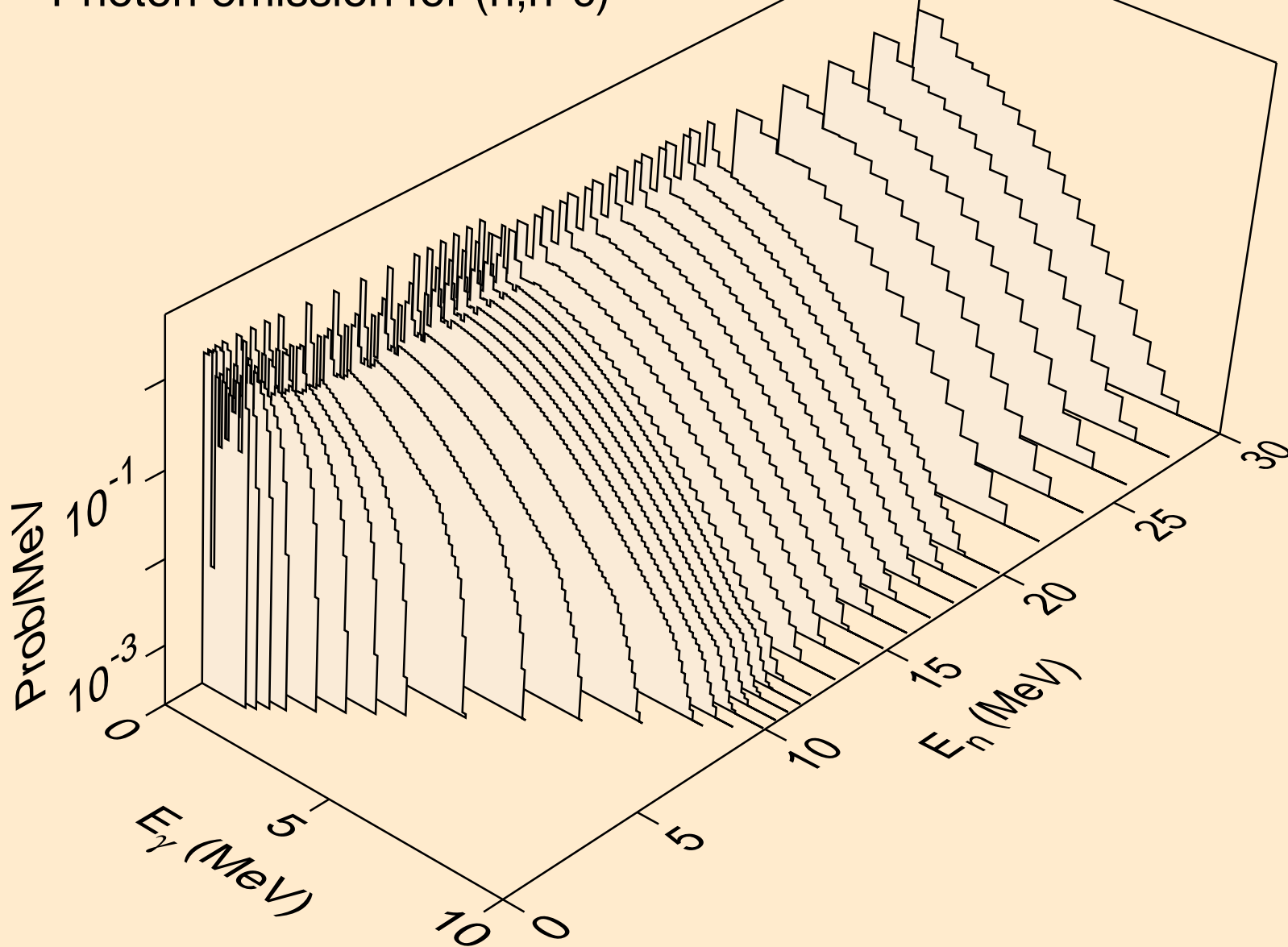

53-I-127 FOR FENDL-3.1 FROM FENDL-3.1 WITH NJOY2012.50+ C  
Photon emission for (n,p\*1)

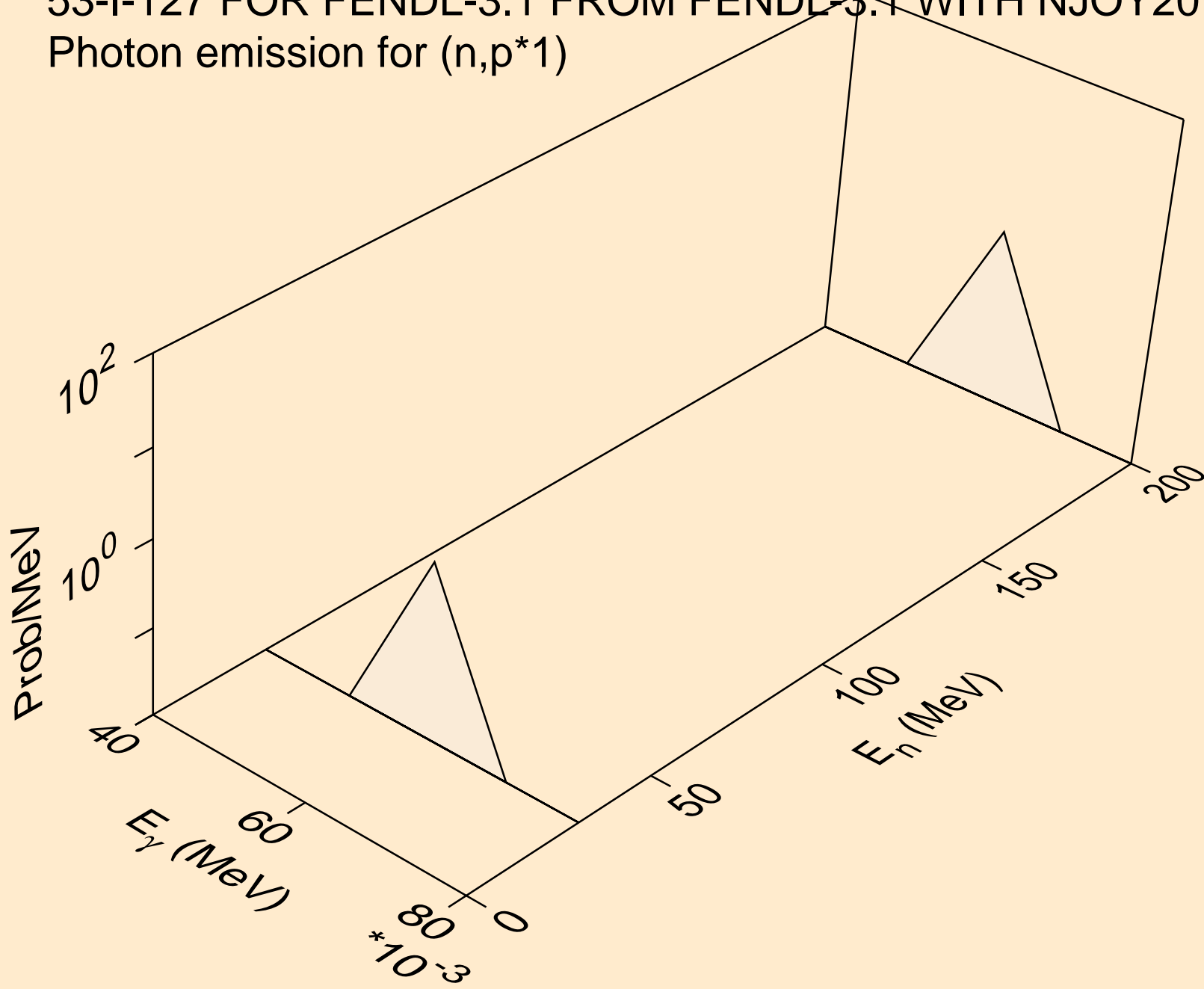



53-I-127 FOR FENDL-3.1 FROM FENDL-3.1 WITH NJOY2012.50+ C  
Photon emission for (n,p\*2)

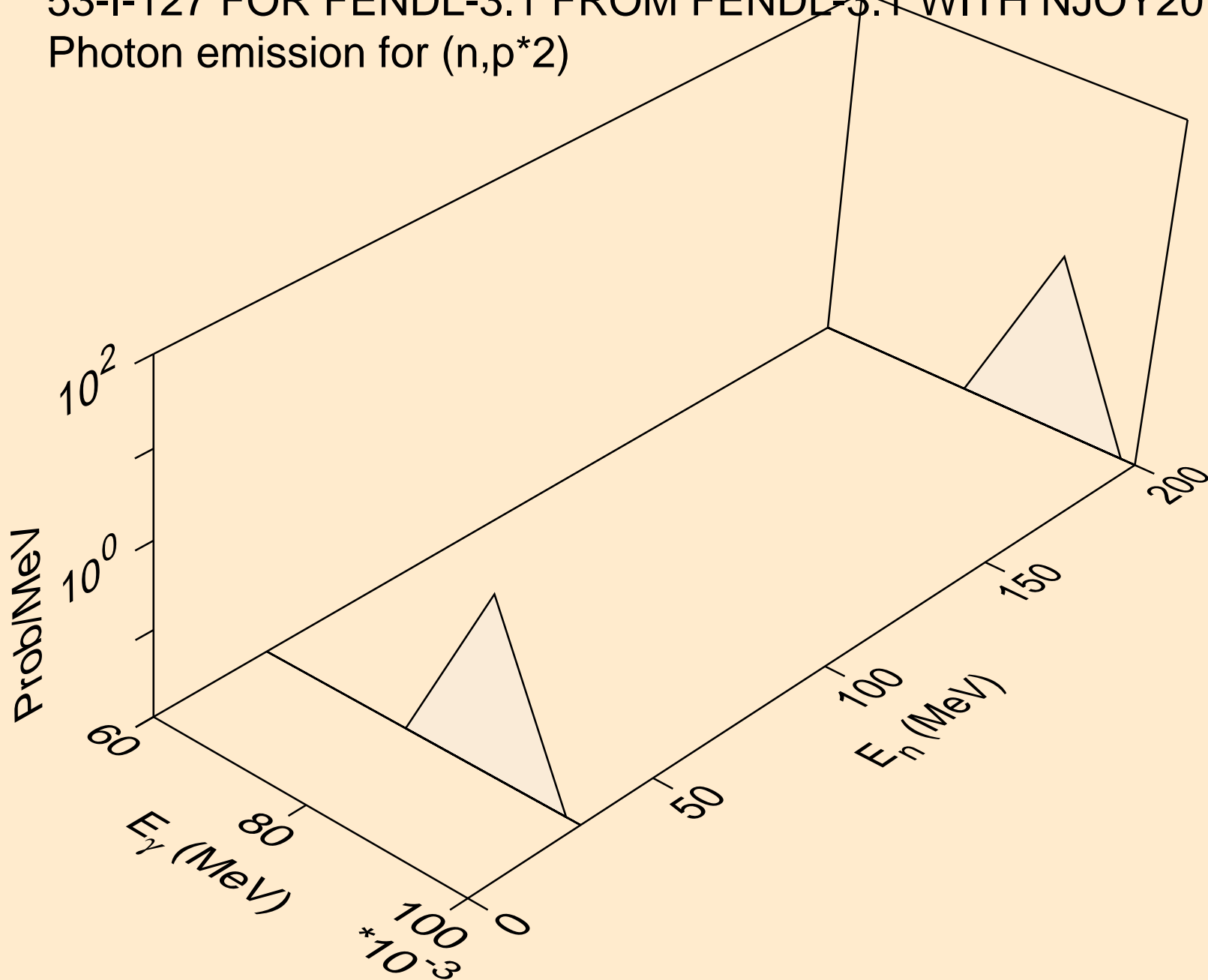

53-I-127 FOR FENDL-3.1 FROM FENDL-3.1 WITH NJOY2012.50+ C  
Photon emission for (n,p\*3)

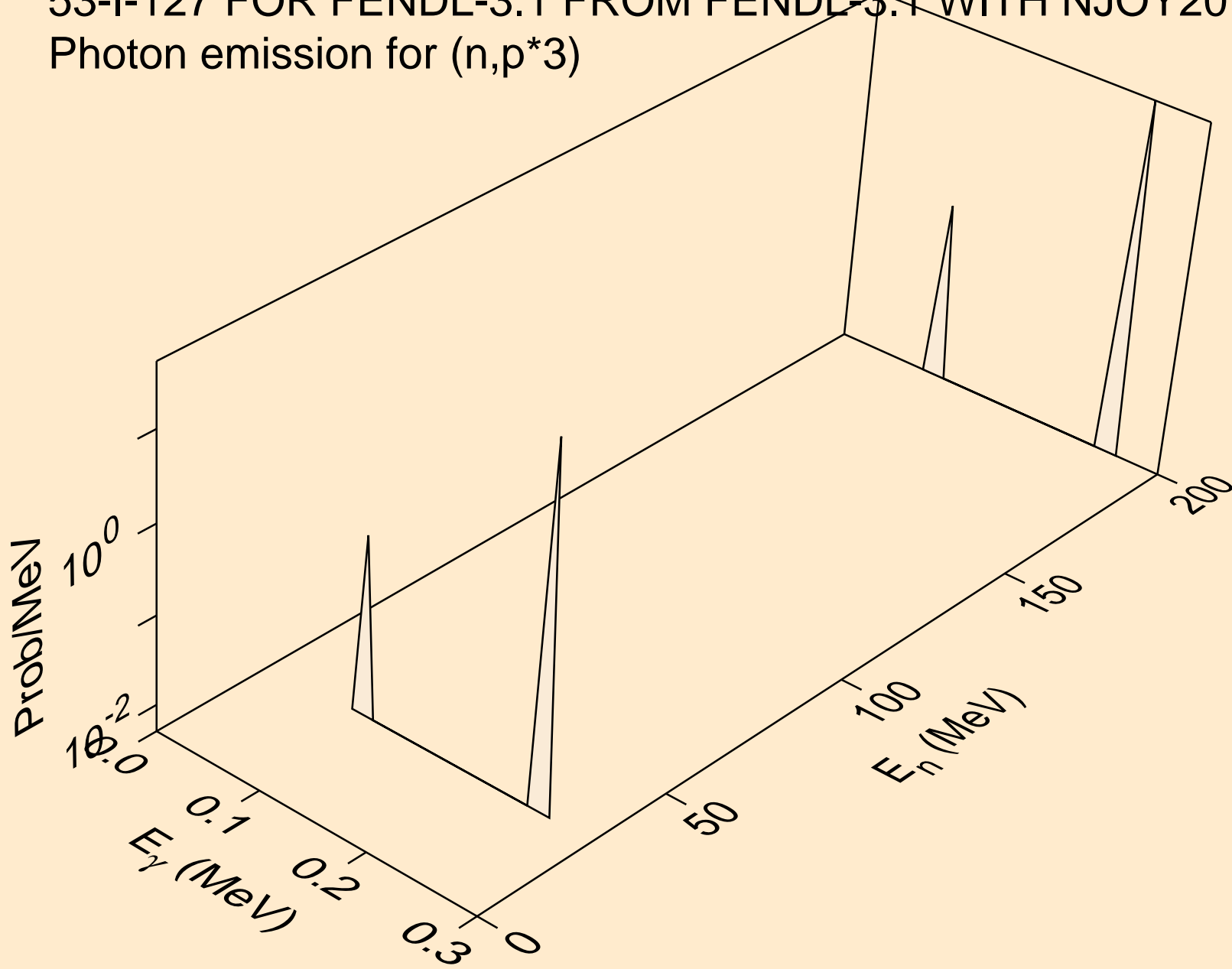

53-I-127 FOR FENDL-3.1 FROM FENDL-3.1 WITH NJOY2012.50+ C  
Photon emission for (n,p\*4)

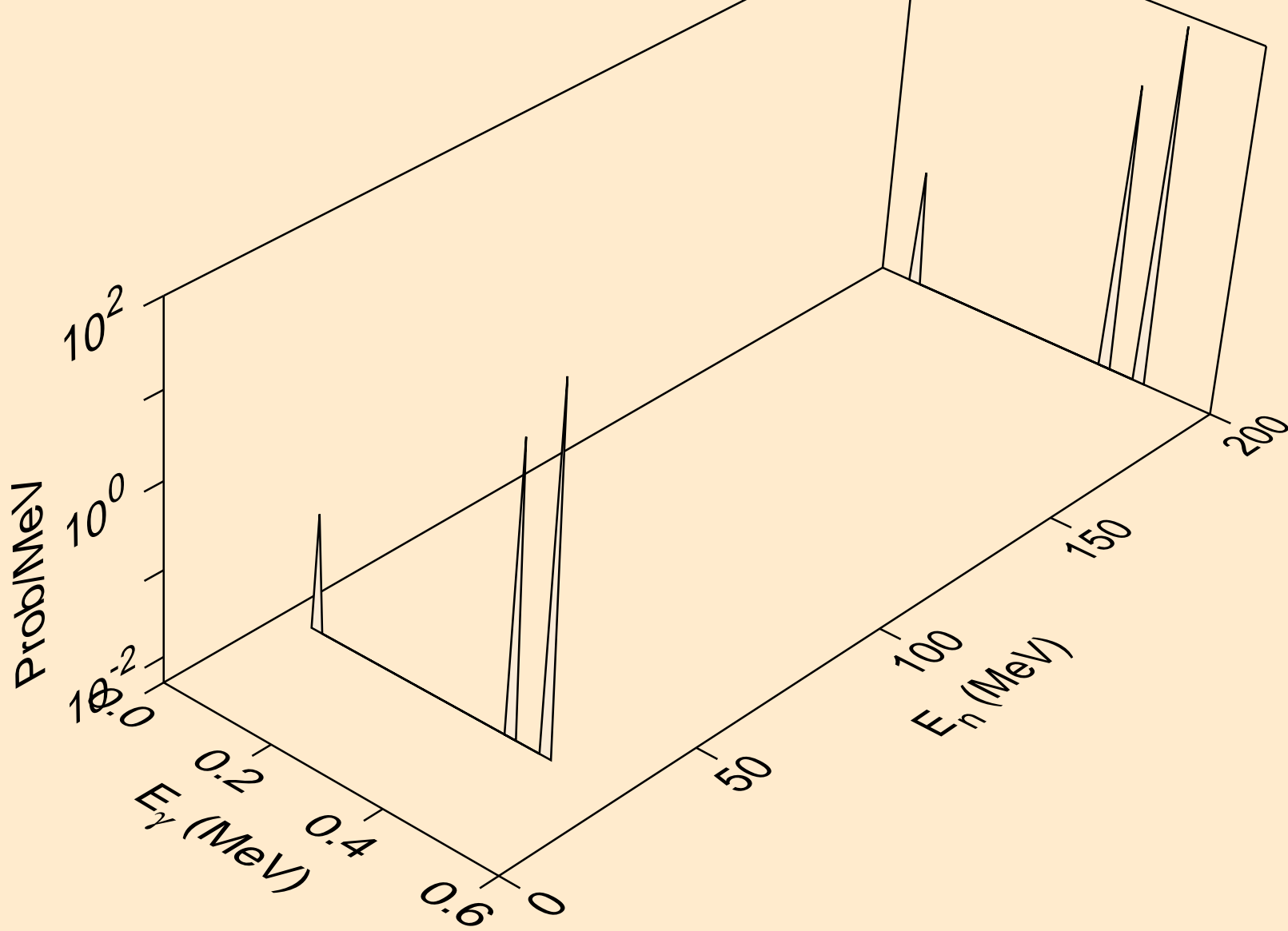

53-I-127 FOR FENDL-3.1 FROM FENDL-3.1 WITH NJOY2012.50+ C  
Photon emission for (n,p\*5)

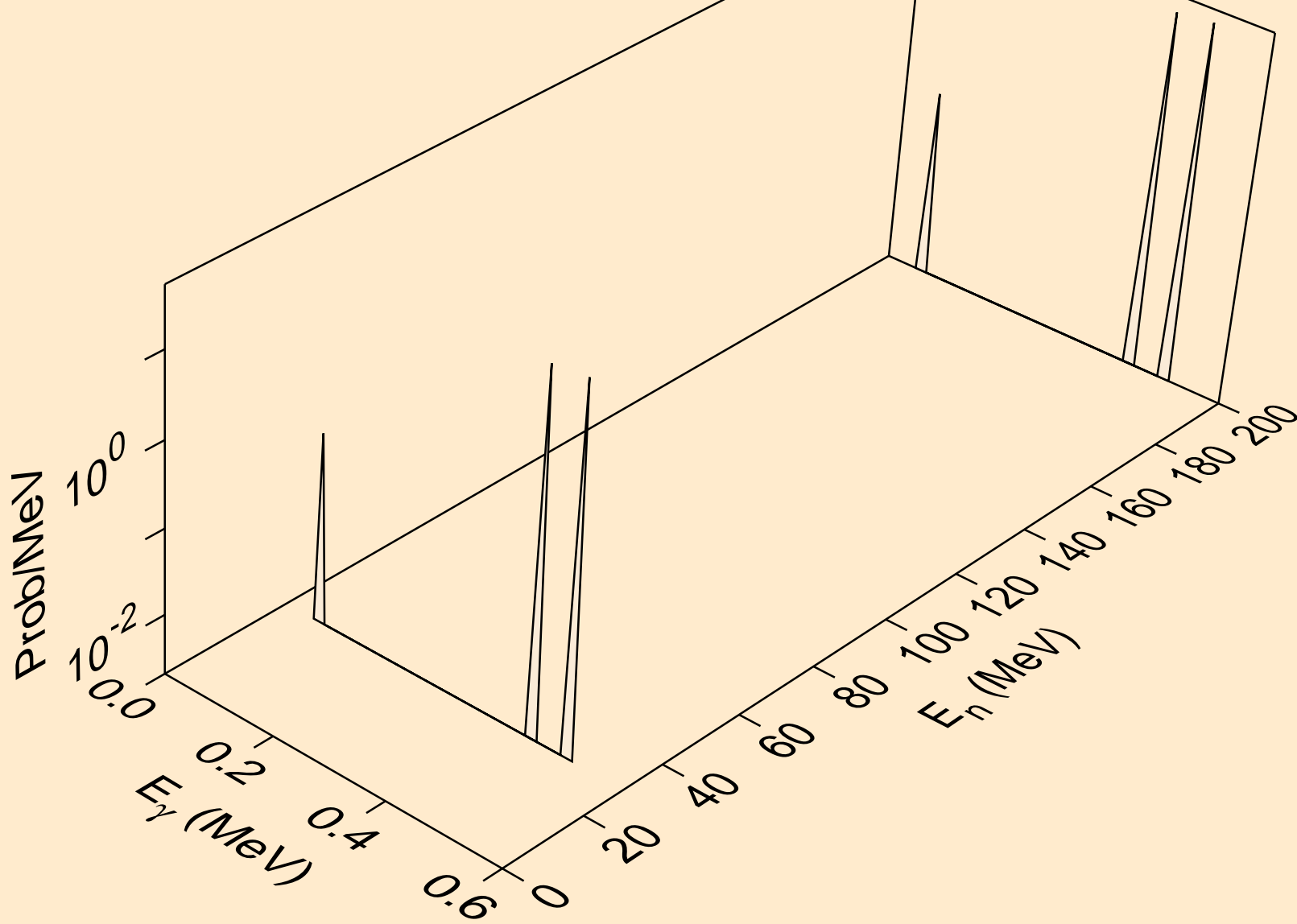

53-I-127 FOR FENDL-3.1 FROM FENDL-3.1 WITH NJOY2012.50+ C  
Photon emission for (n,p\*6)

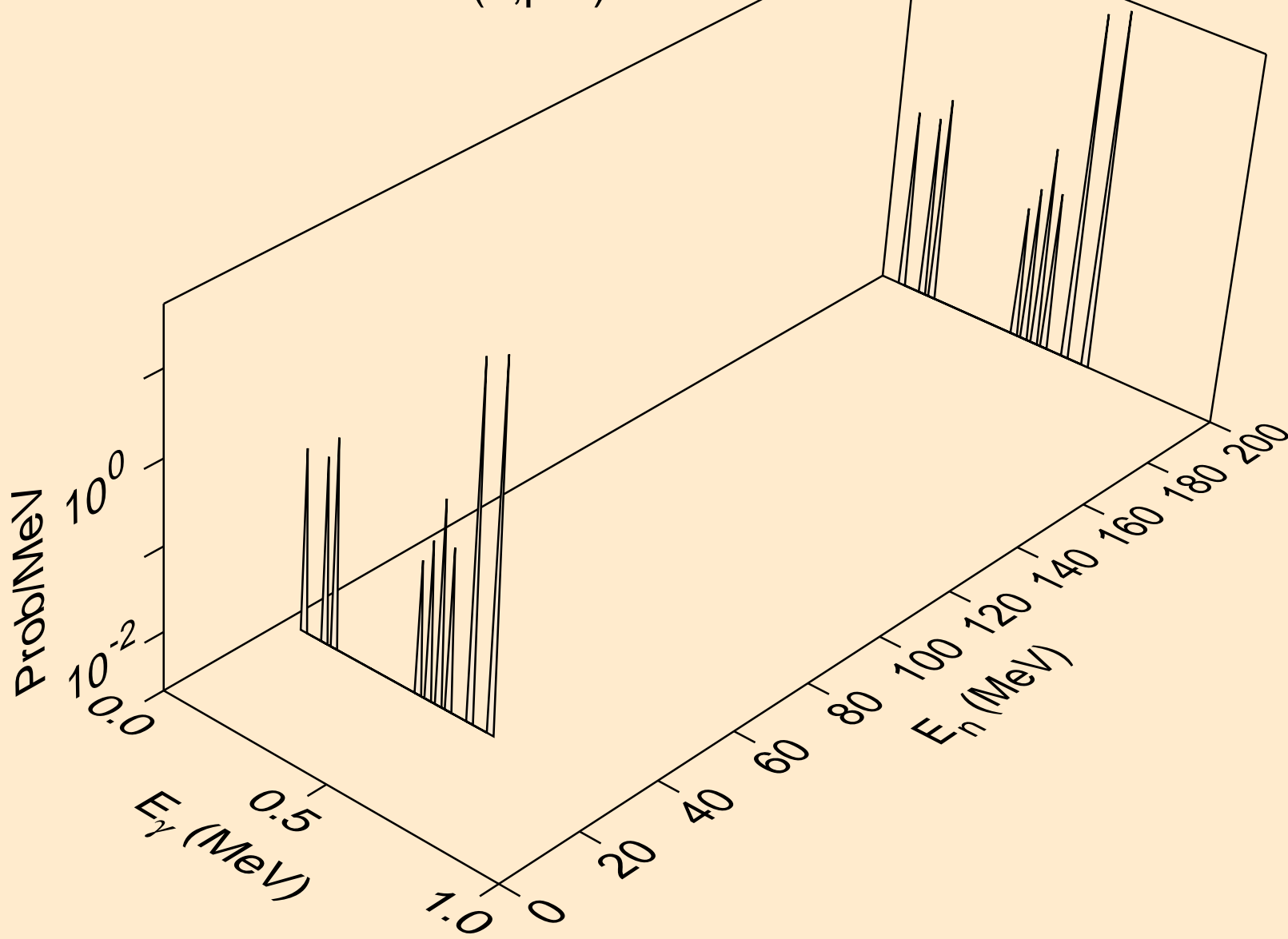

53-I-127 FOR FENDL-3.1 FROM FENDL-3.1 WITH NJOY2012.50+ C  
Photon emission for (n,p\*7)

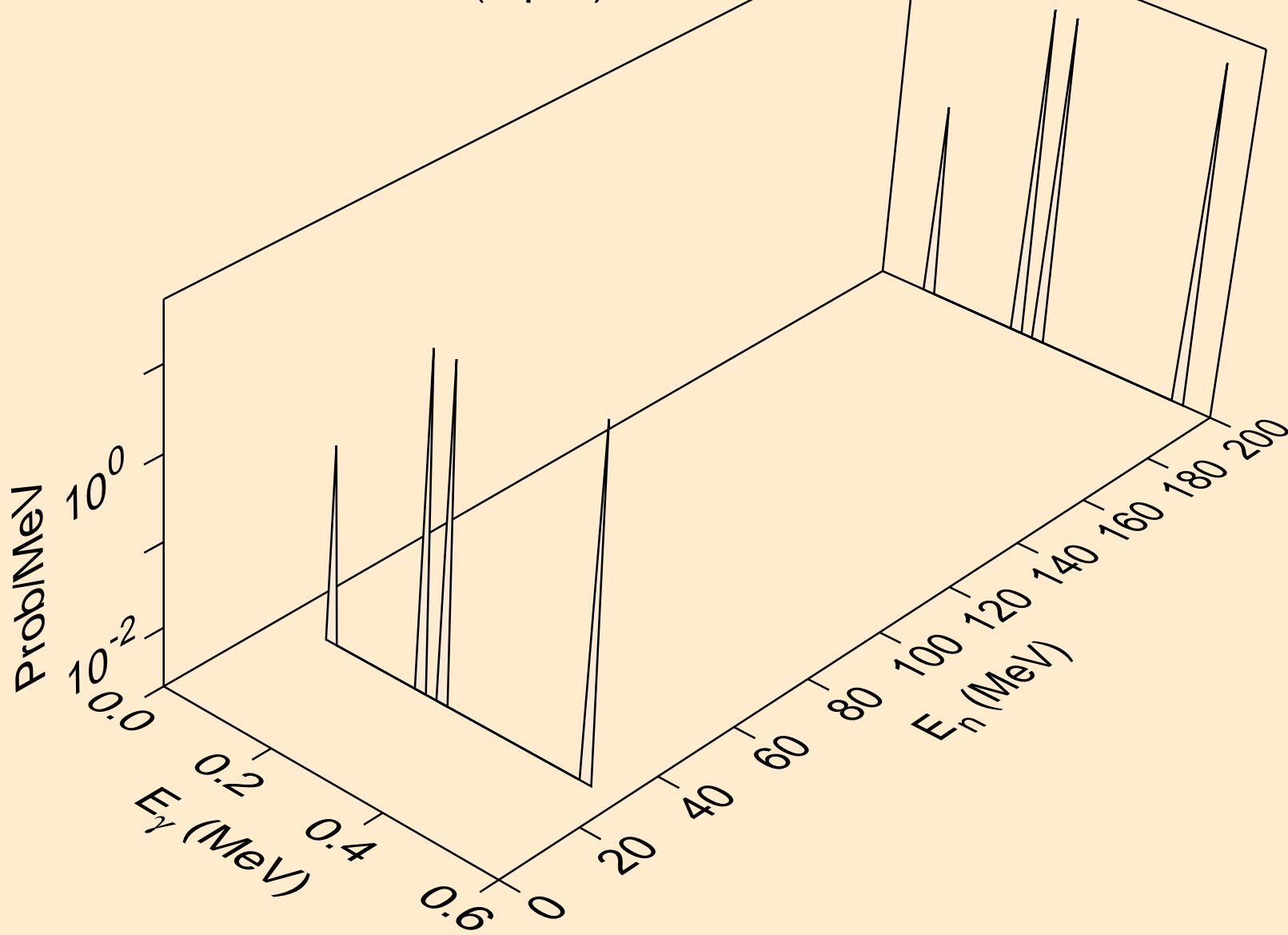

53-I-127 FOR FENDL-3.1 FROM FENDL-3.1 WITH NJOY2012.50+ C  
Photon emission for (n,p\*8)

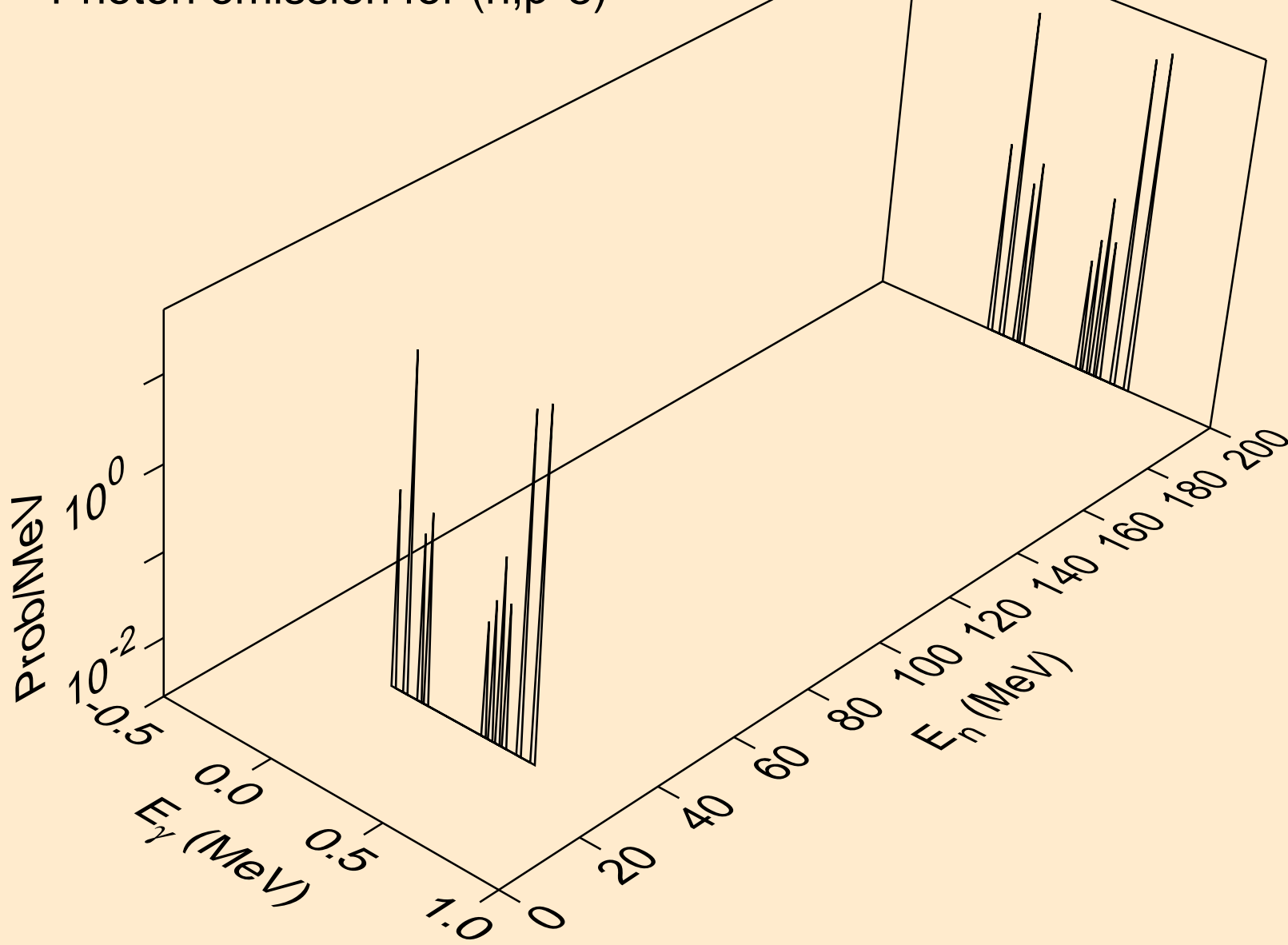

53-I-127 FOR FENDL-3.1 FROM FENDL-3.1 WITH NJOY2012.50+ C  
Photon emission for (n,p\*9)

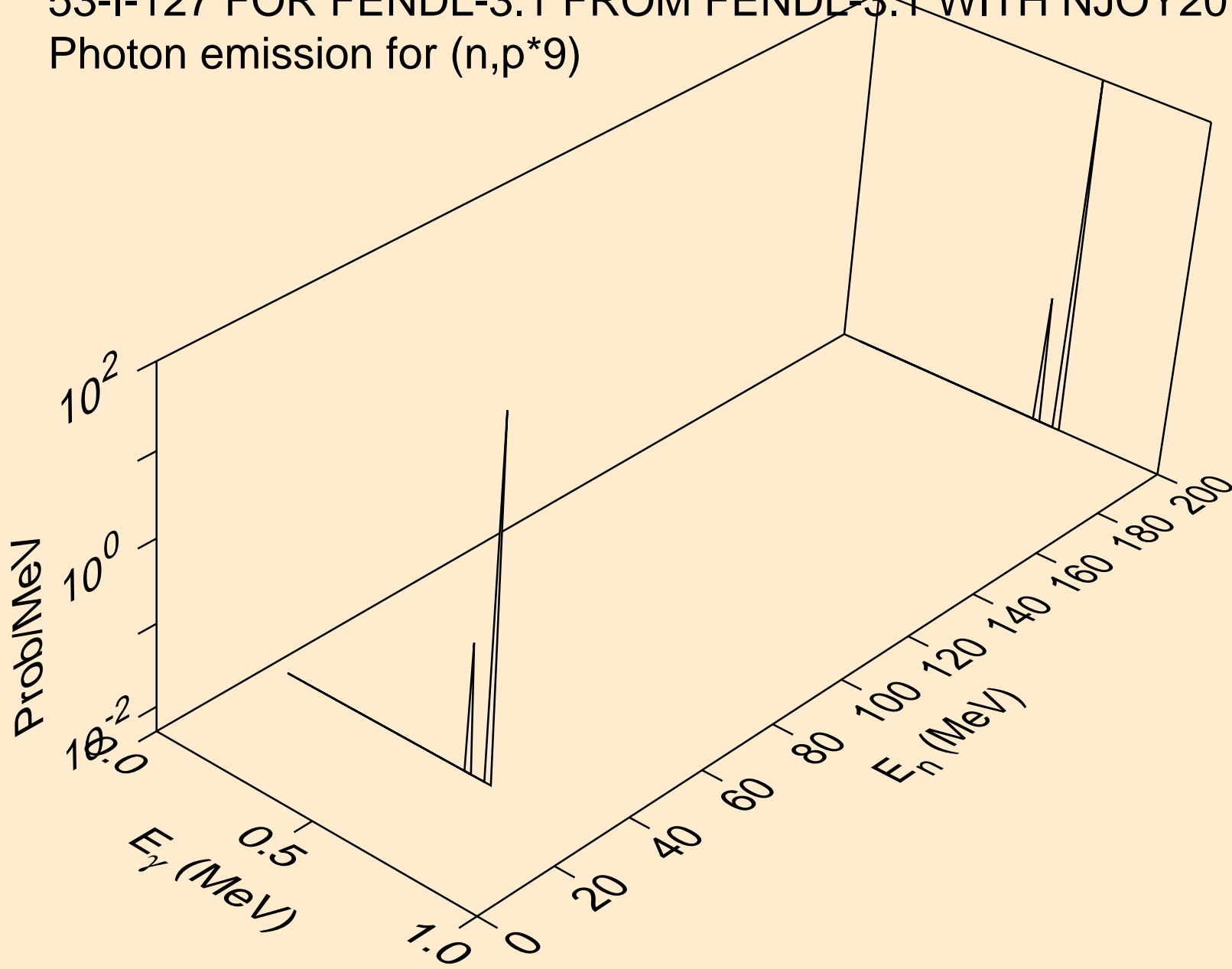



53-I-127 FOR FENDL-3.1 FROM FENDL-3.1 WITH NJOY2012.50+ C  
Photon emission for (n,p\*10)

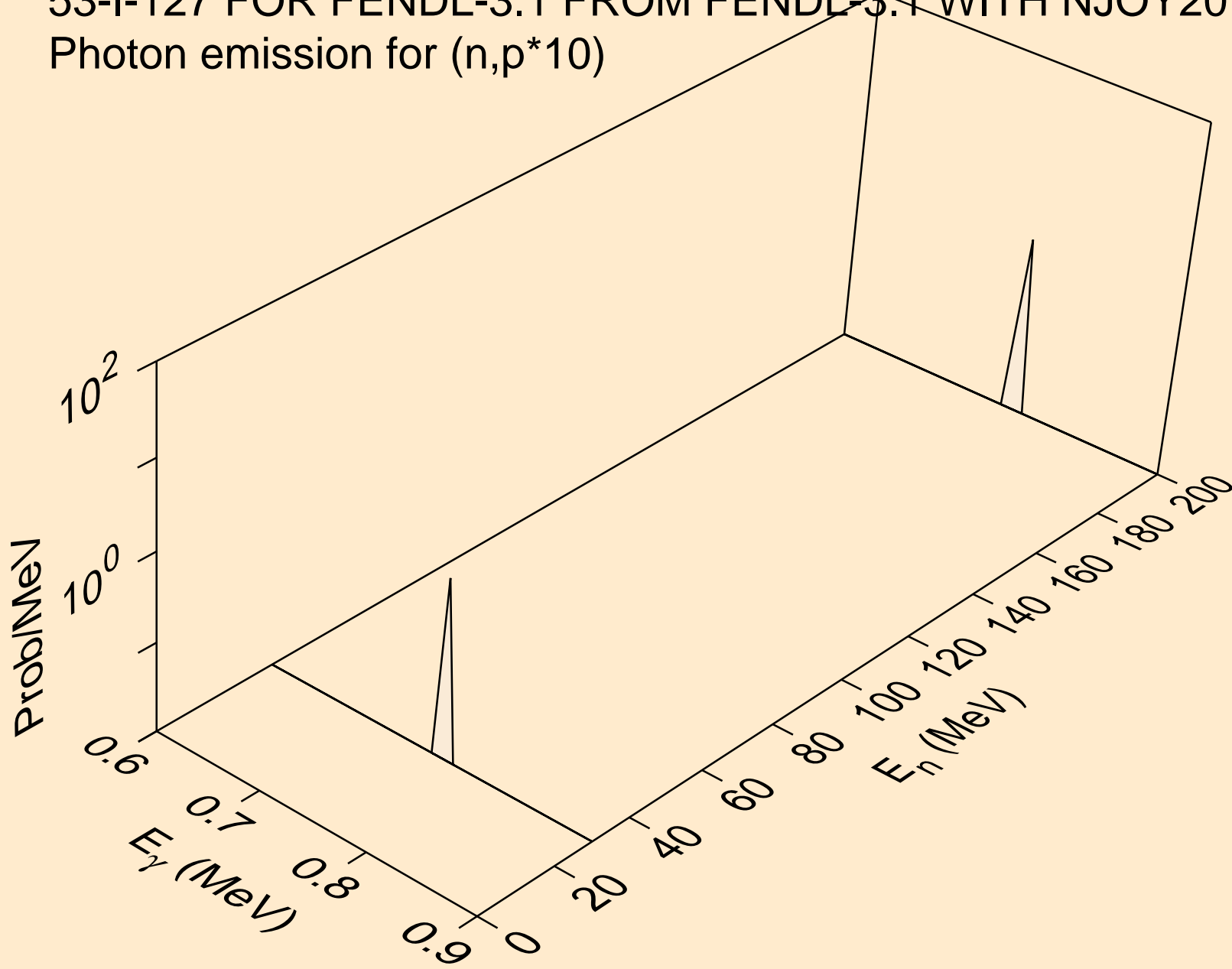

53-I-127 FOR FENDL-3.1 FROM FENDL-3.1 WITH NJOY2012.50+ C  
Photon emission for (n,p\*11)

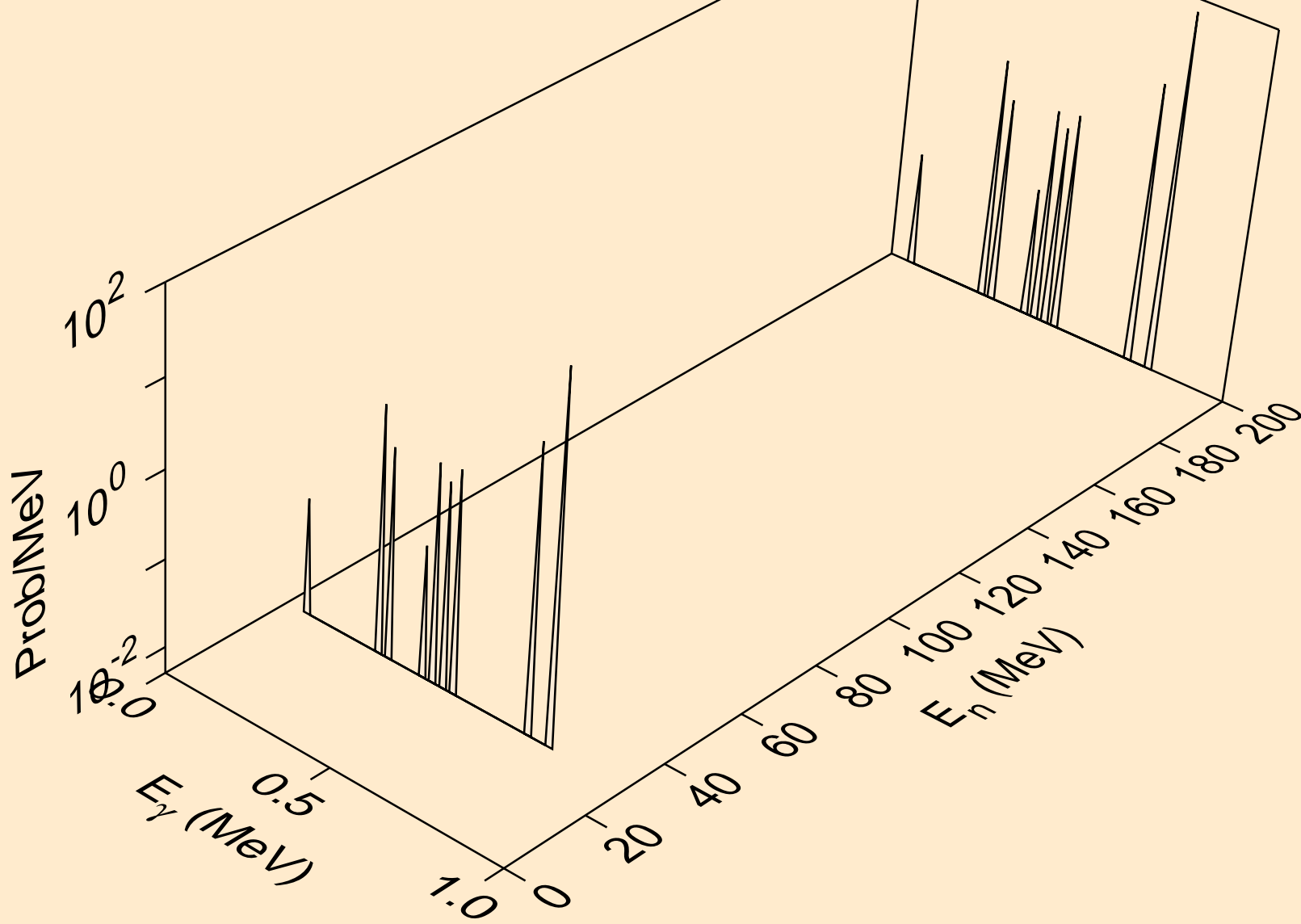

53-I-127 FOR FENDL-3.1 FROM FENDL-3.1 WITH NJOY2012.50+ C  
Photon emission for (n,p\*12)

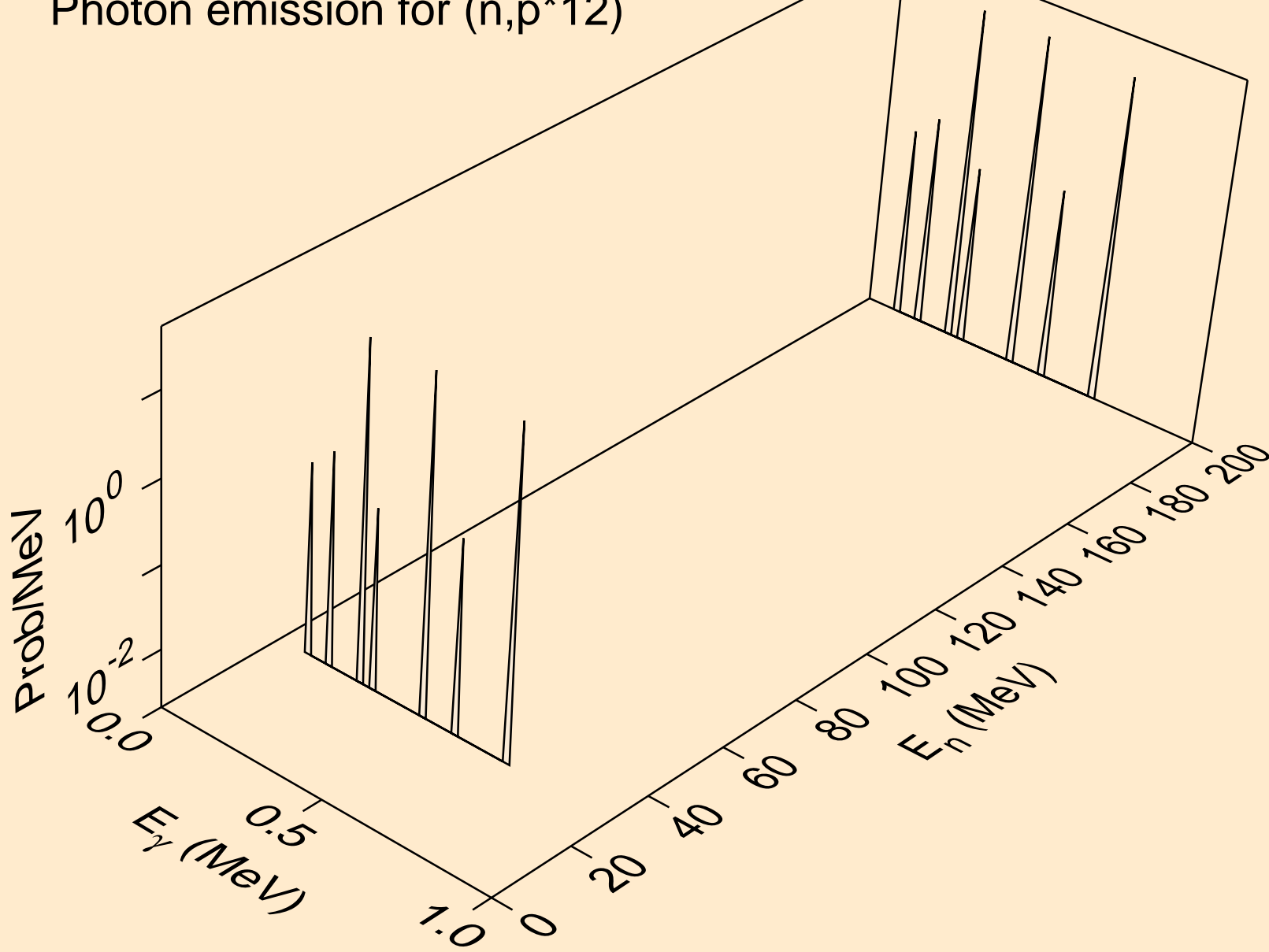

53-I-127 FOR FENDL-3.1 FROM FENDL-3.1 WITH NJOY2012.50+ C  
Photon emission for (n,p\*13)

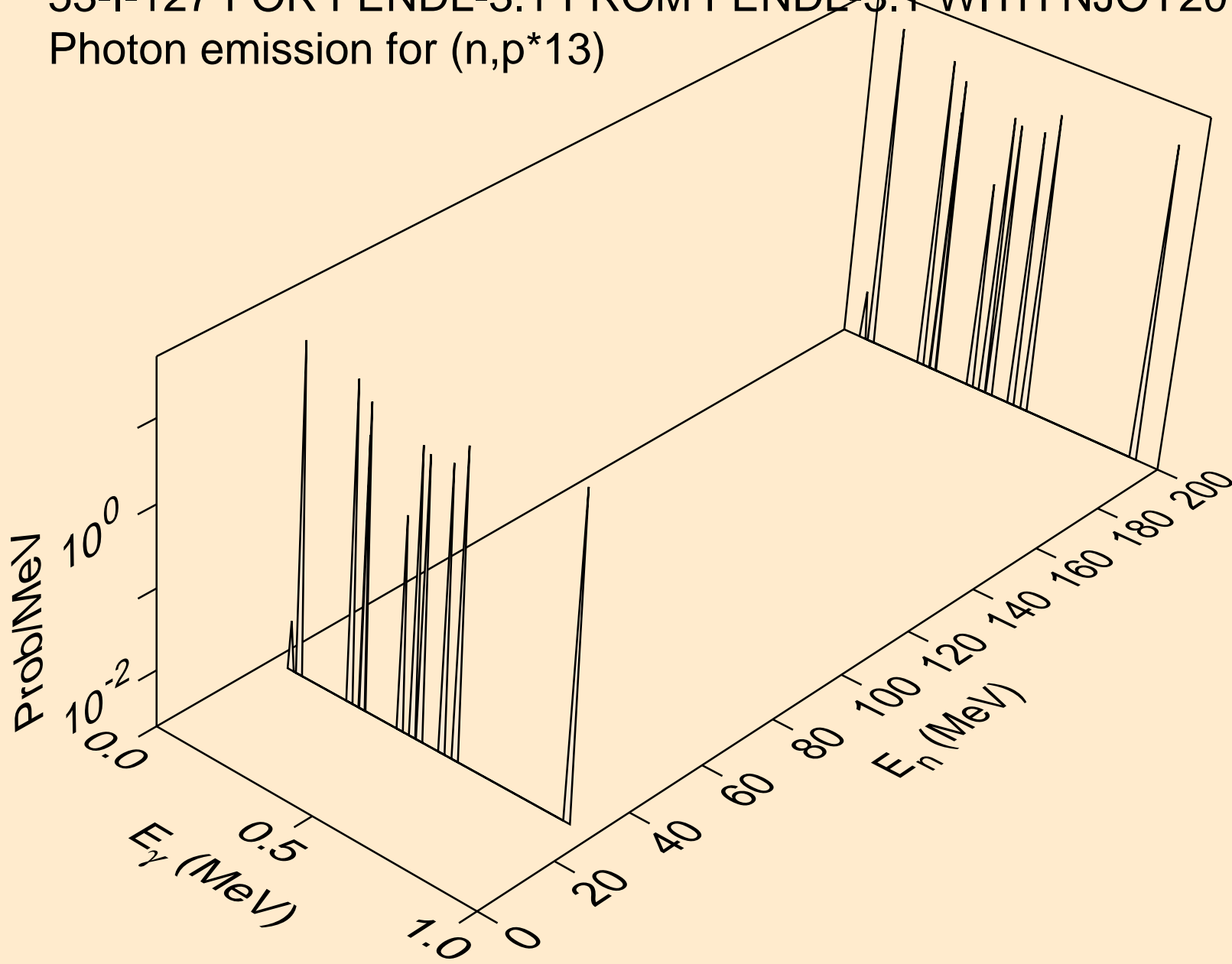

53-I-127 FOR FENDL-3.1 FROM FENDL-3.1 WITH NJOY2012.50+ C  
Photon emission for (n,p\*14)

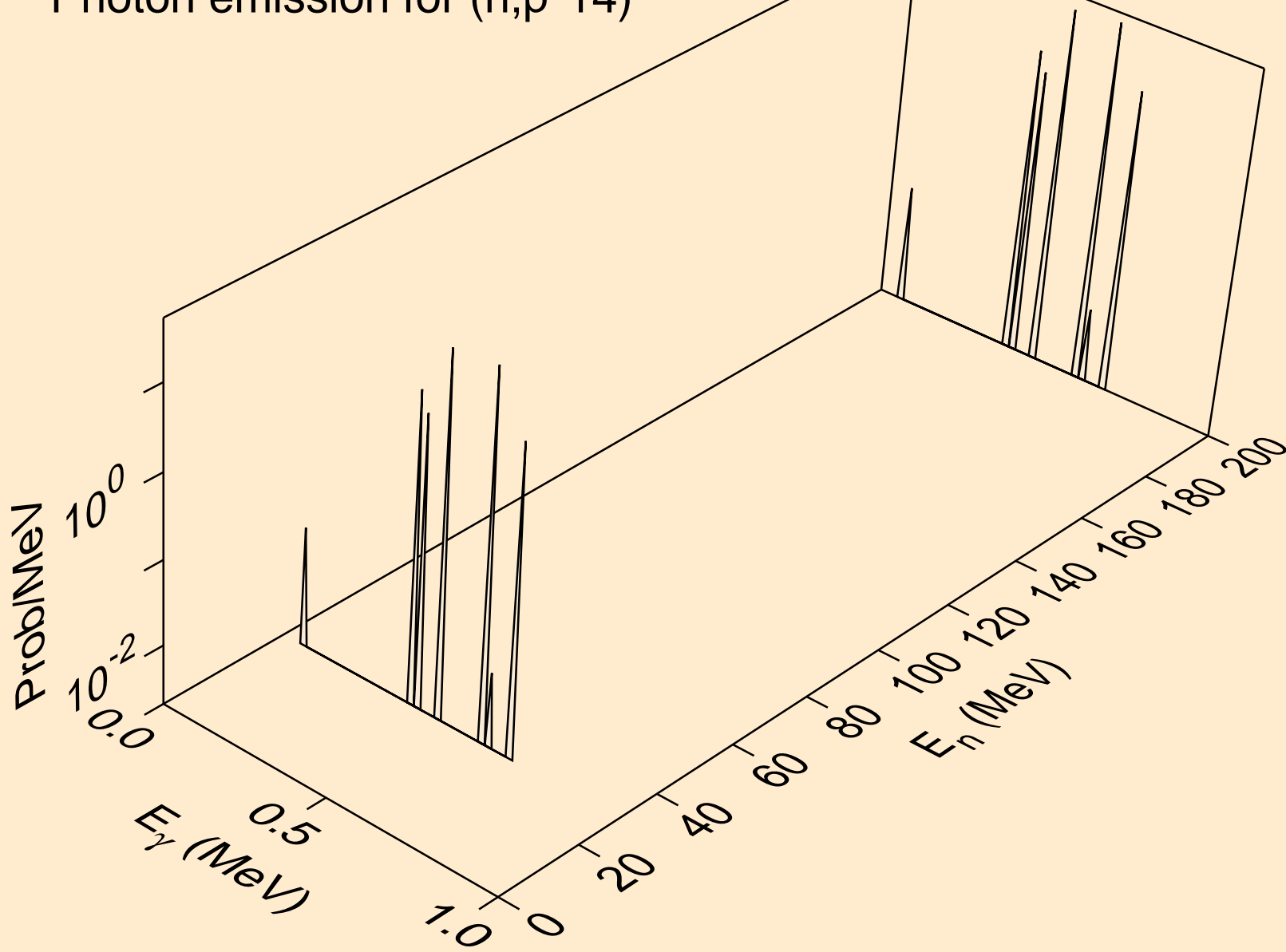

53-I-127 FOR FENDL-3.1 FROM FENDL-3.1 WITH NJOY2012.50+ C  
Photon emission for (n,p\*15)

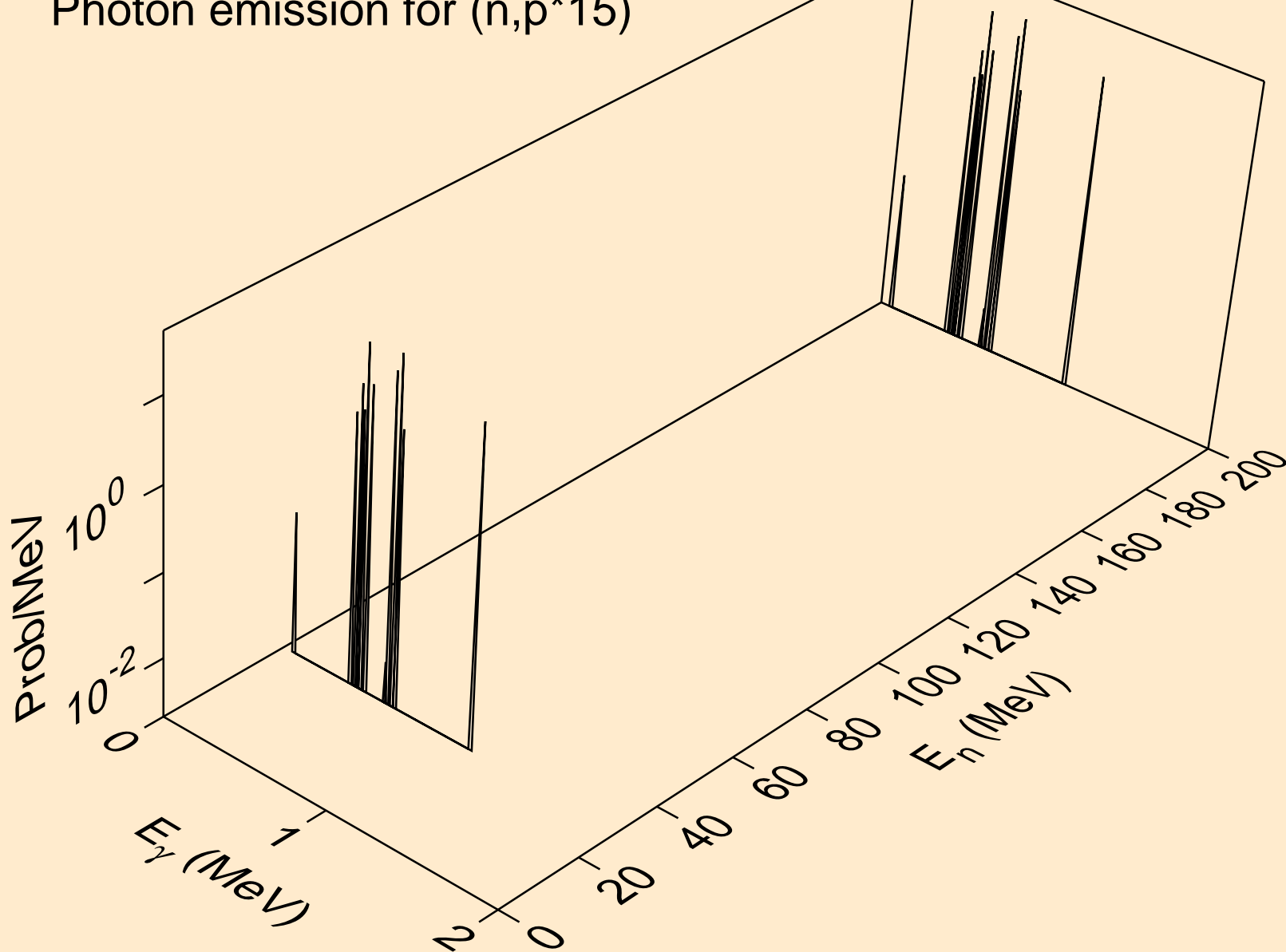

53-I-127 FOR FENDL-3.1 FROM FENDL-3.1 WITH NJOY2012.50+ C  
Photon emission for (n,p\*16)

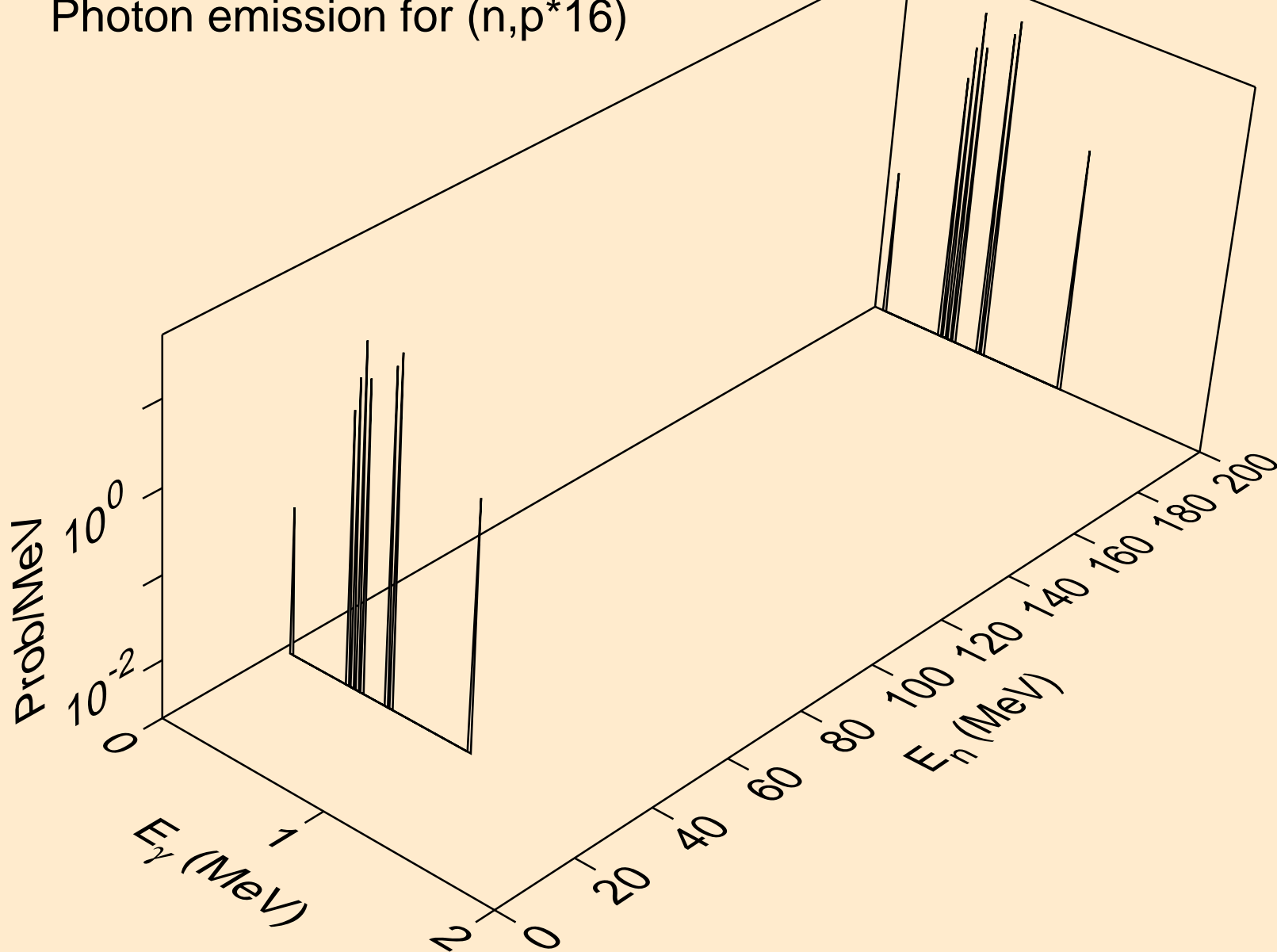

53-I-127 FOR FENDL-3.1 FROM FENDL-3.1 WITH NJOY2012.50+ C  
Photon emission for (n,p\*17)

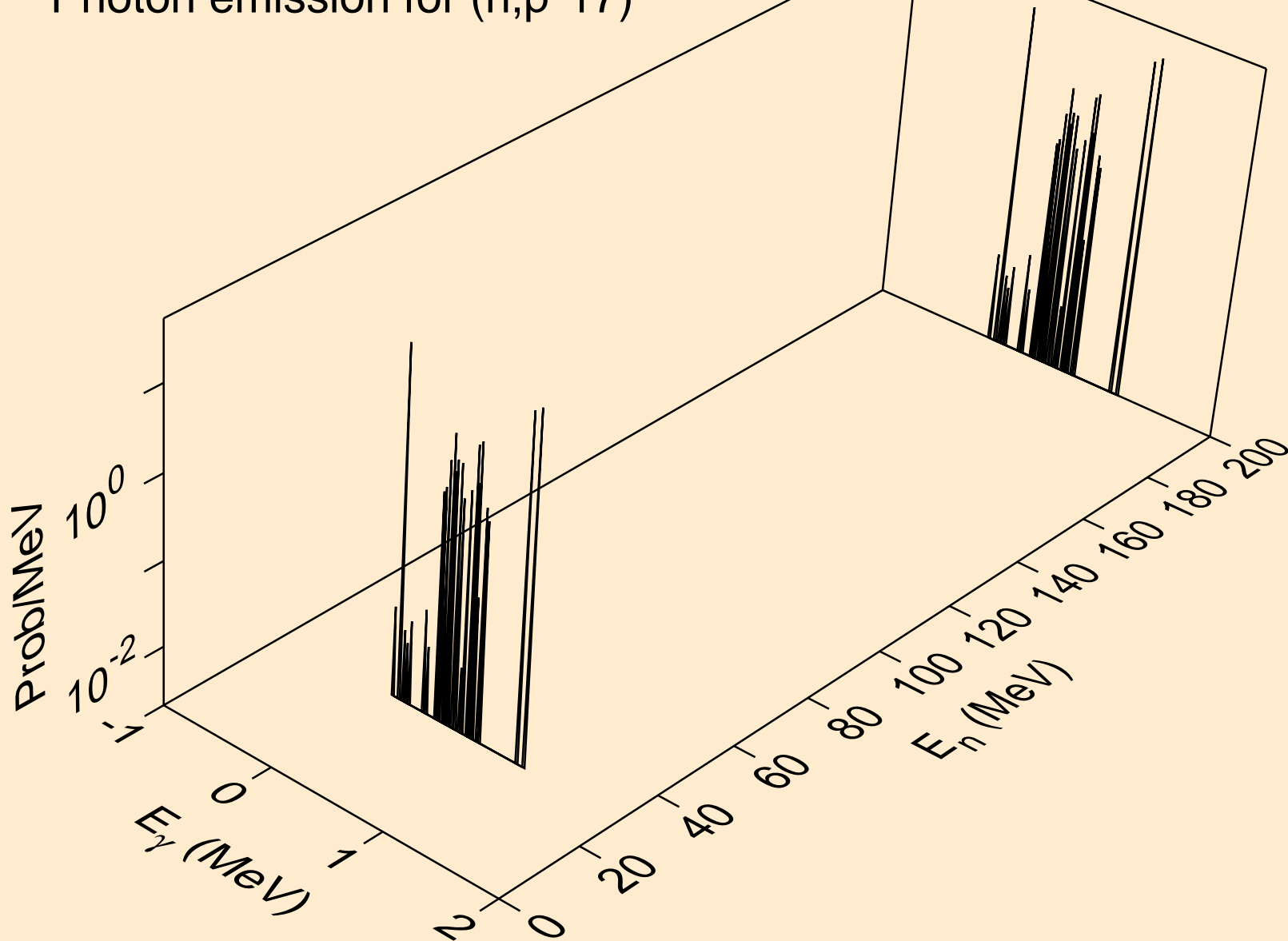



53-I-127 FOR FENDL-3.1 FROM FENDL-3.1 WITH NJOY2012.50+ C  
Photon emission for (n,p\*18)

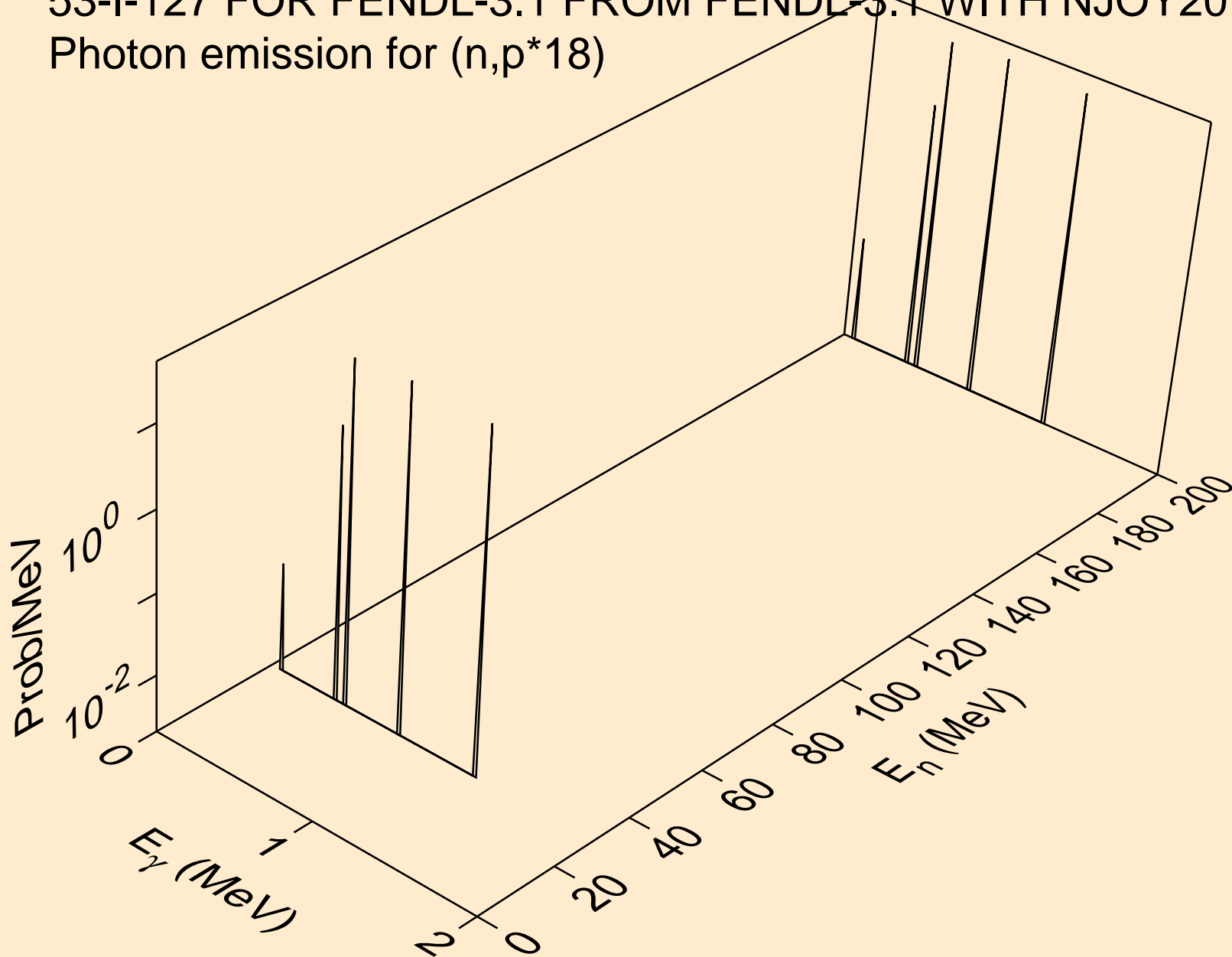

53-I-127 FOR FENDL-3.1 FROM FENDL-3.1 WITH NJOY2012.50+ C  
Photon emission for (n,p\*19)

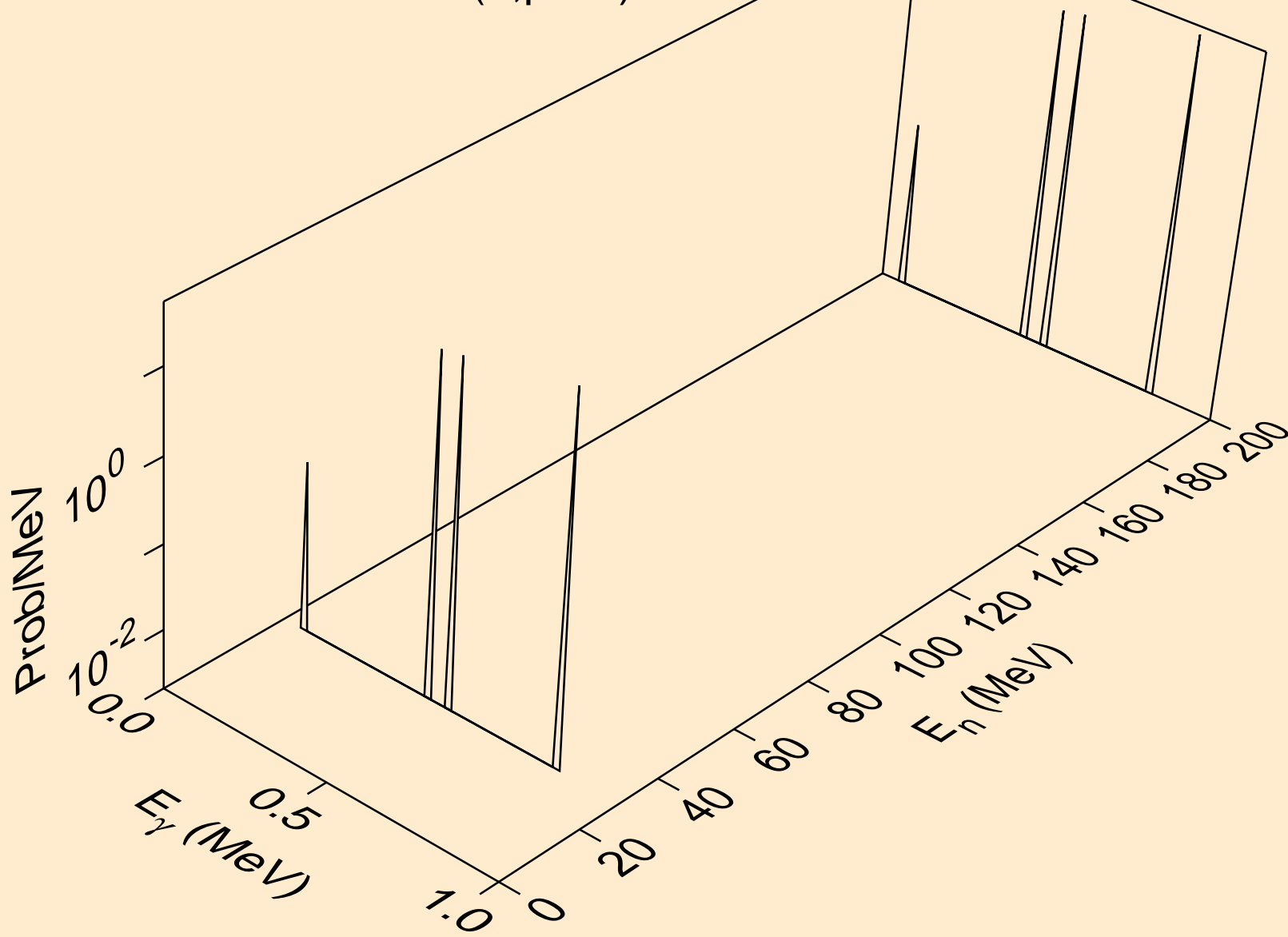

53-I-127 FOR FENDL-3.1 FROM FENDL-3.1 WITH NJOY2012.50+ C  
Photon emission for (n,p\*20)

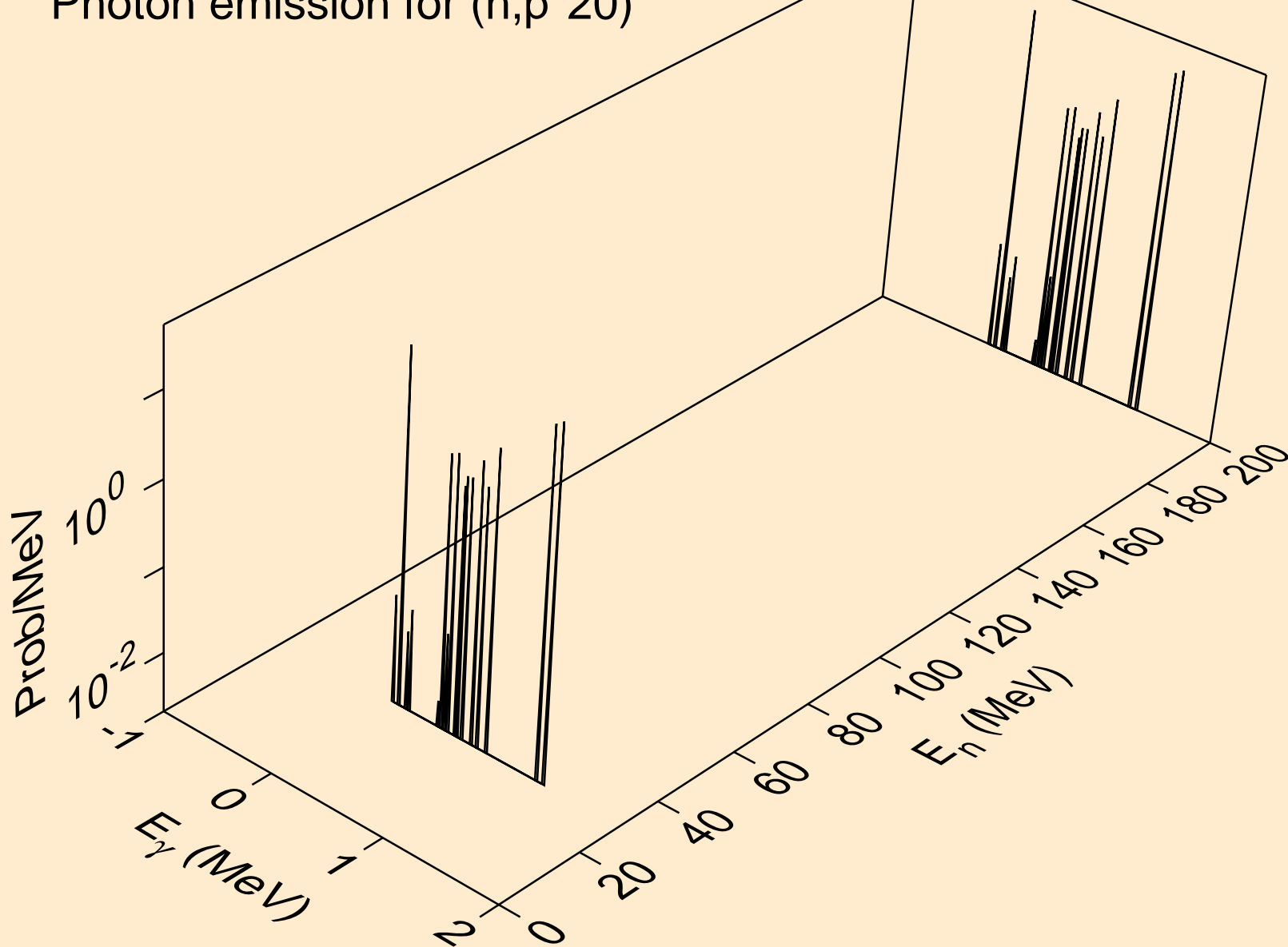

53-I-127 FOR FENDL-3.1 FROM FENDL-3.1 WITH NJOY2012.50+ C  
Photon emission for (n,p\*21)

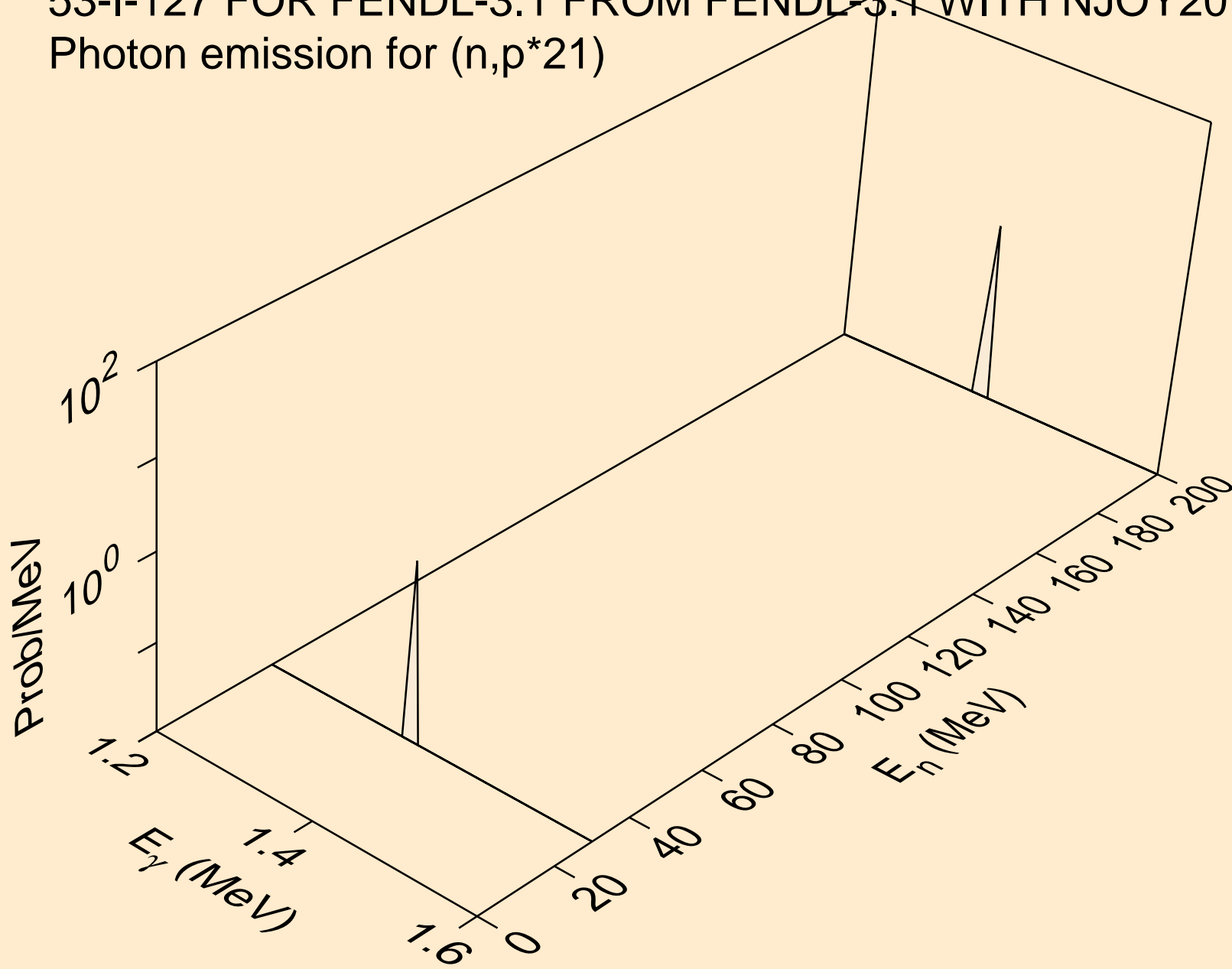

53-I-127 FOR FENDL-3.1 FROM FENDL-3.1 WITH NJOY2012.50+ C  
Photon emission for (n,p\*22)

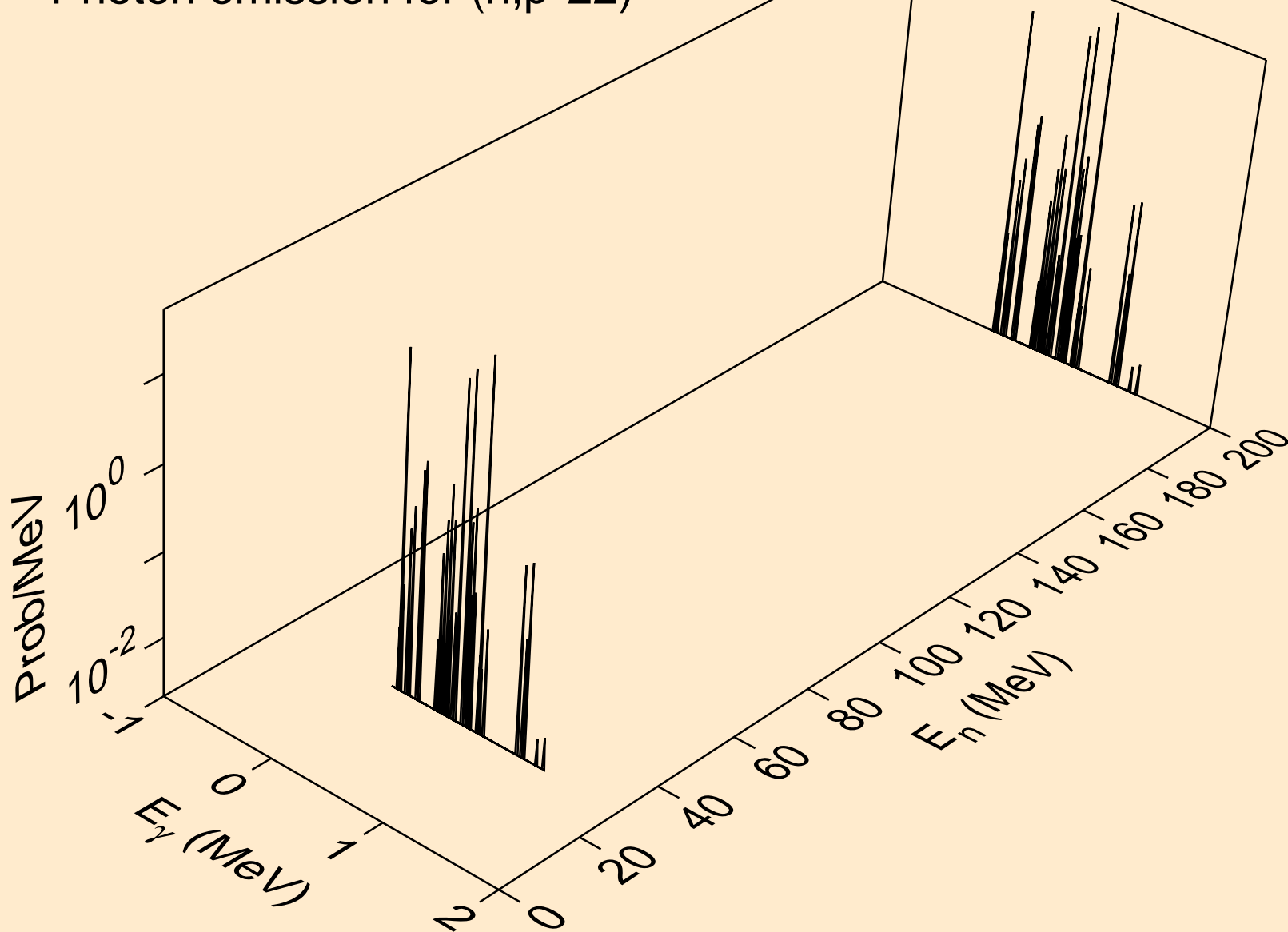

53-I-127 FOR FENDL-3.1 FROM FENDL-3.1 WITH NJOY2012.50+ C  
Photon emission for (n,p\*c)

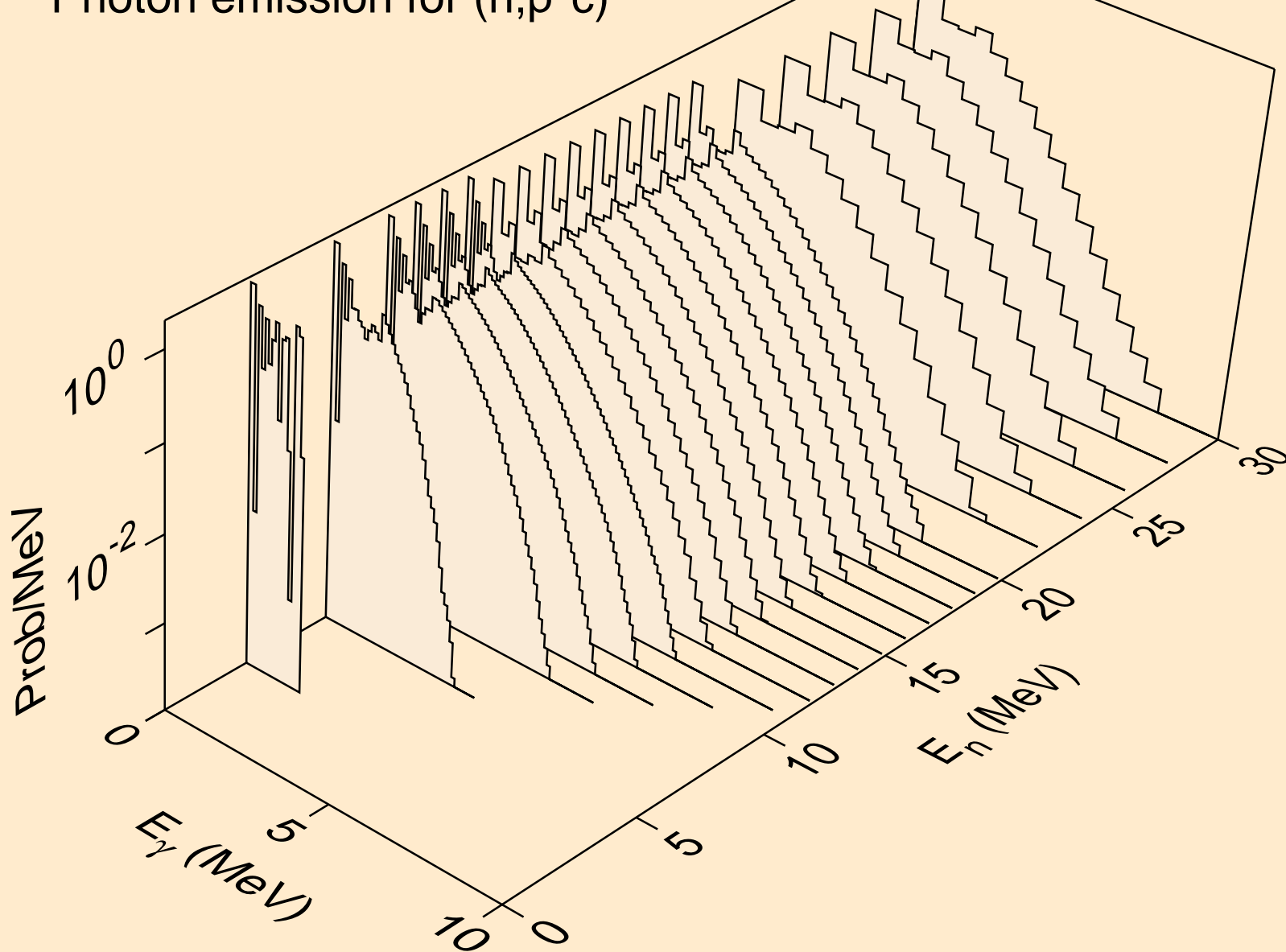

53-I-127 FOR FENDL-3.1 FROM FENDL-3.1 WITH NJOY2012.50+ C  
Photon emission for (n,a\*1)

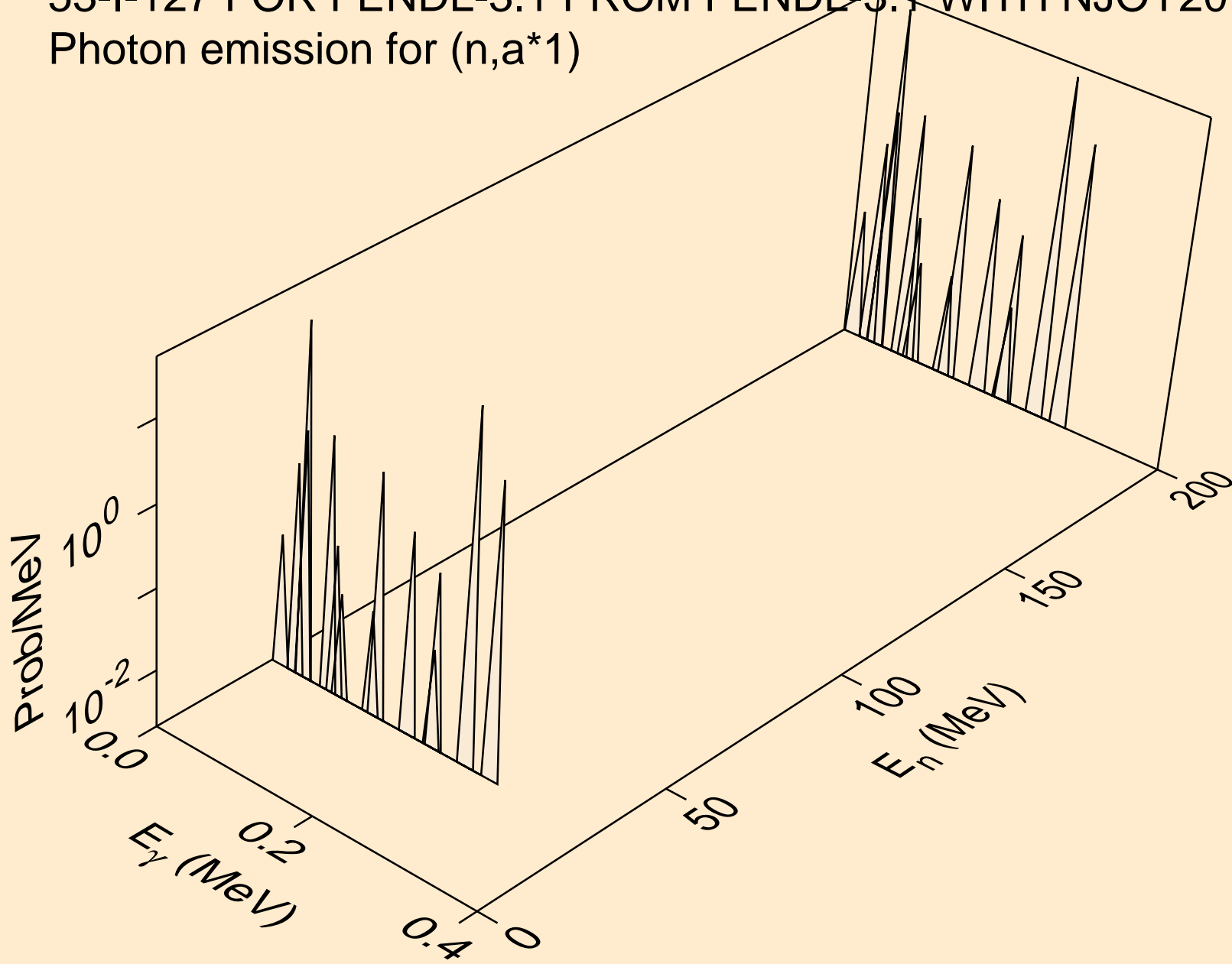

53-I-127 FOR FENDL-3.1 FROM FENDL-3.1 WITH NJOY2012.50+ C  
Photon emission for (n,a\*c)

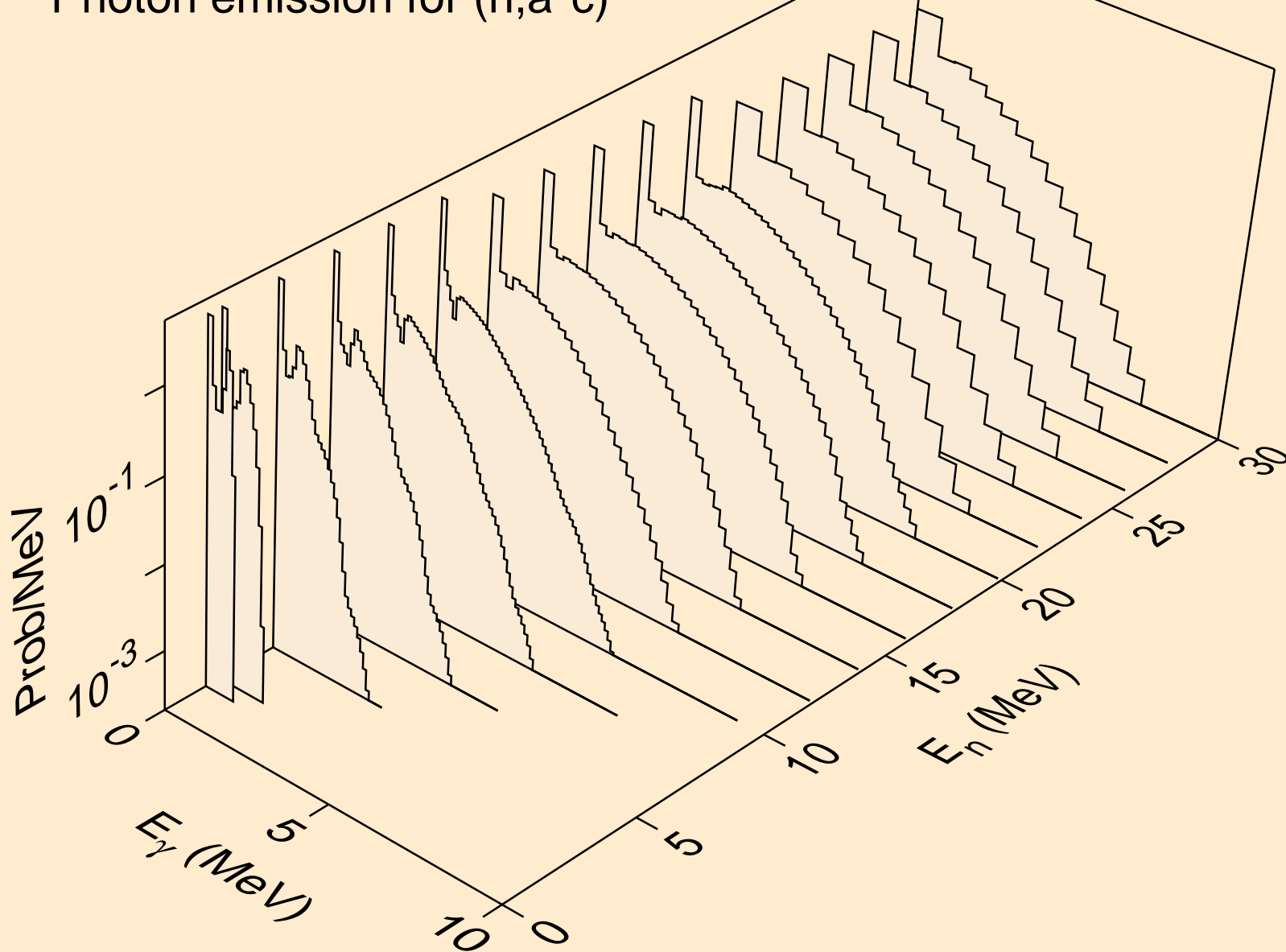



53-I-127 FOR FENDL-3.1 FROM FENDL-3.1 WITH NJOY2012.50+ C  
thermal capture photon spectrum

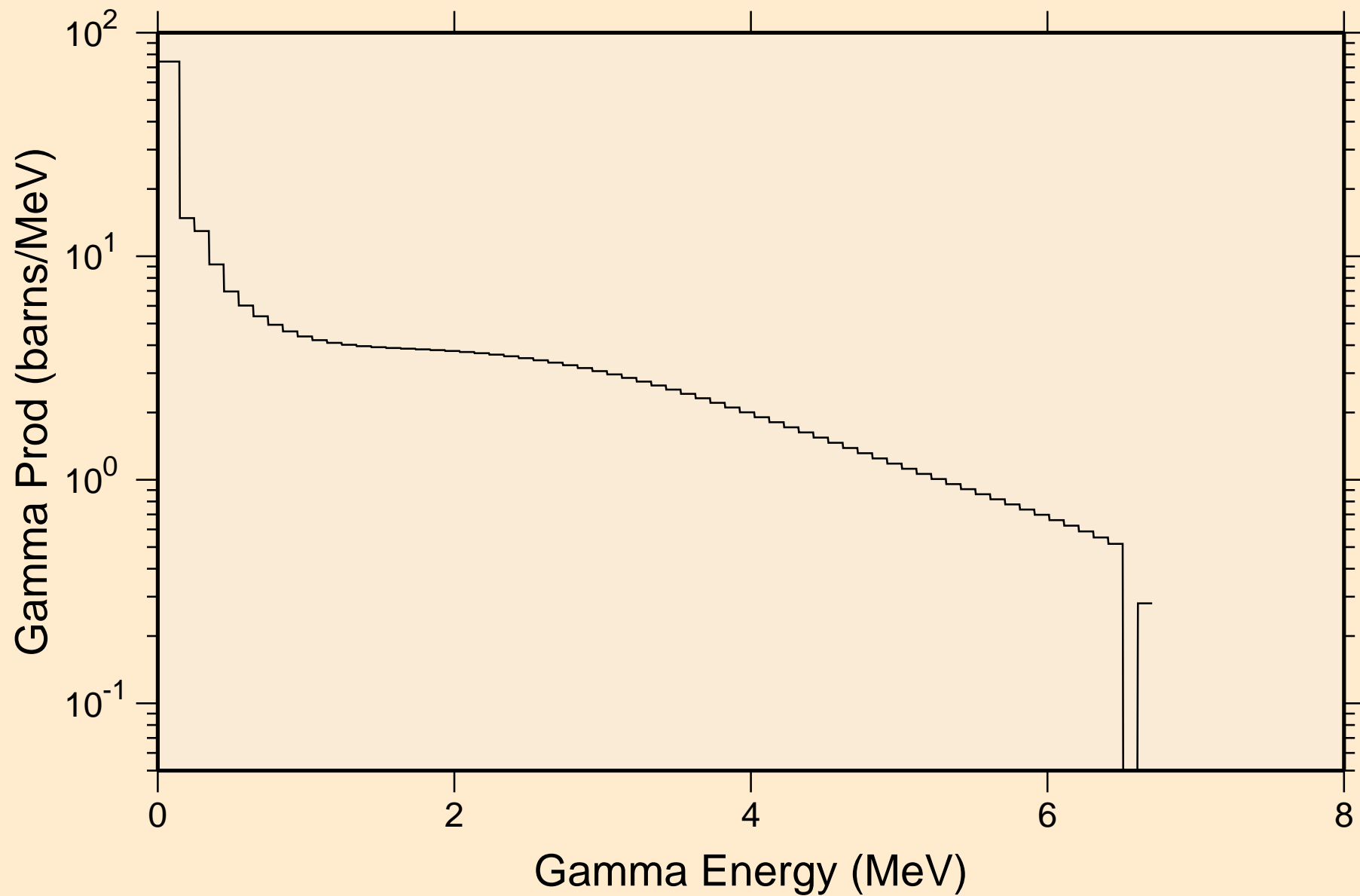

53-I-127 FOR FENDL-3.1 FROM FENDL-3.1 WITH NJOY2012.50+ C  
14 MeV photon spectrum

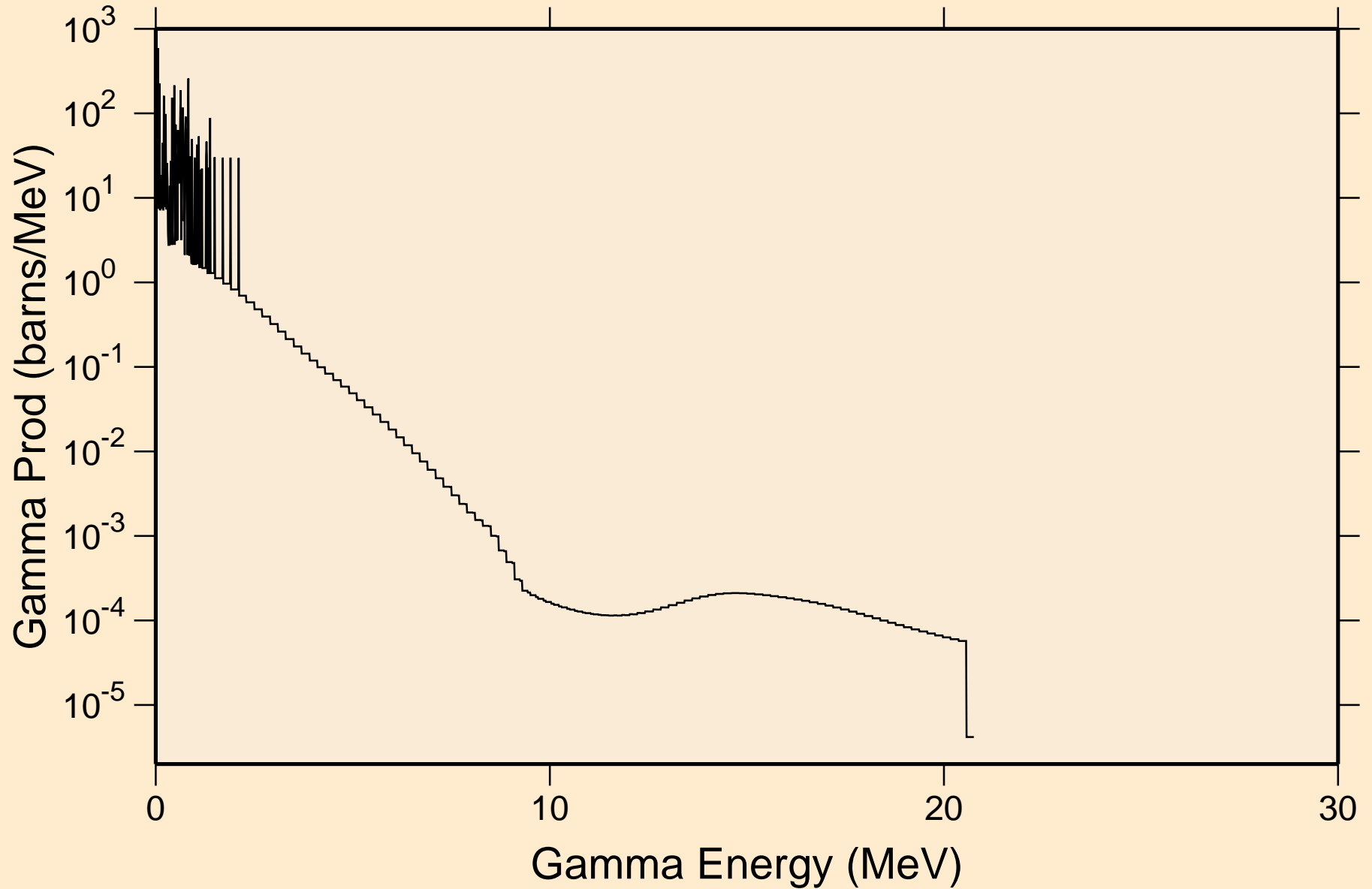

# 53-I-127 FOR FENDL-3.1 FROM FENDL-3.1 WITH NJOY2012.50+ C

## Particle heating contributions

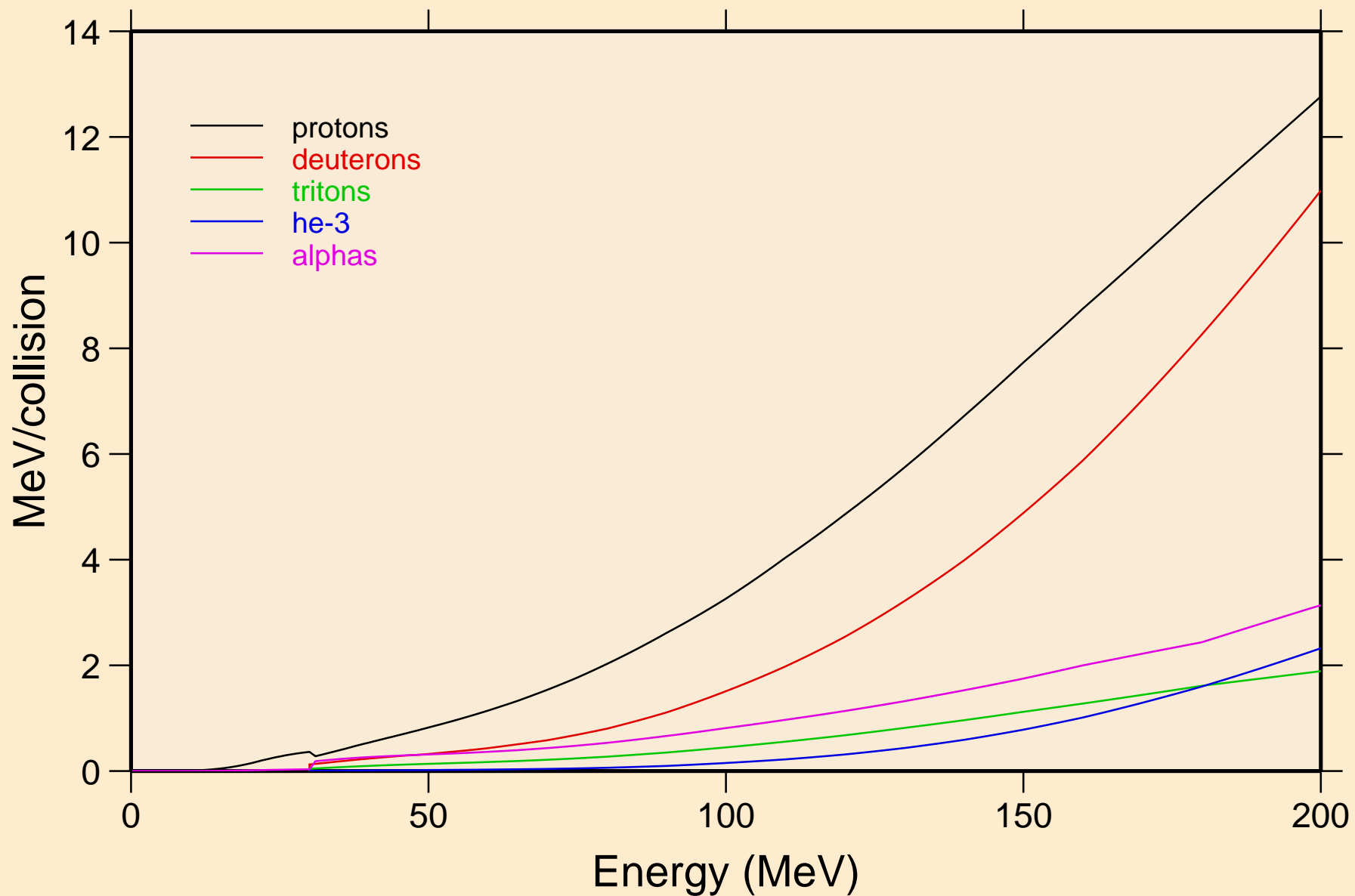

# 53-I-127 FOR FENDL-3.1 FROM FENDL-3.1 WITH NJOY2012.50+ C Recoil Heating

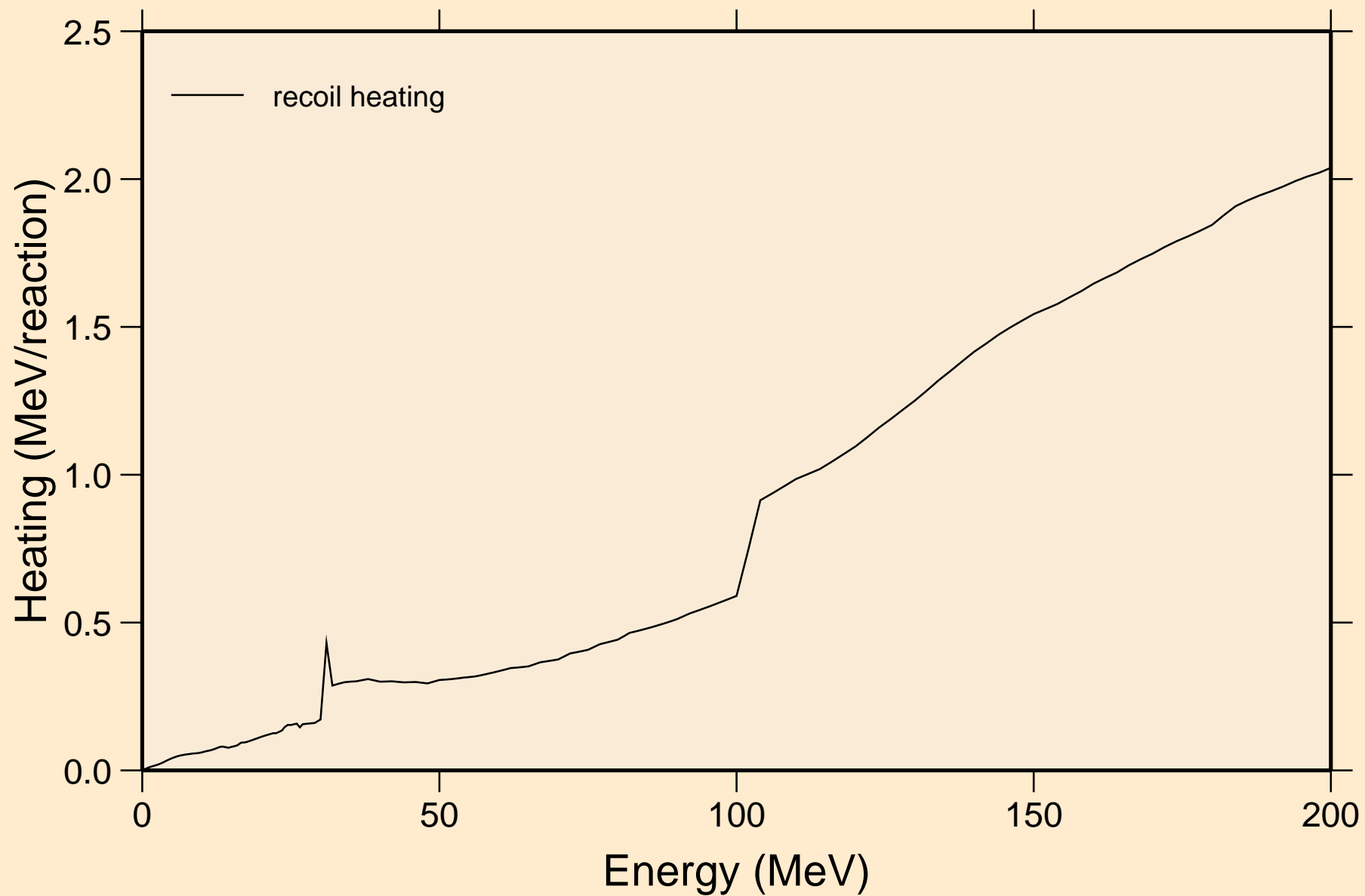

53-I-127 FOR FENDL-3.1 FROM FENDL-3.1 WITH NJOY2012.50+ C  
Particle production cross sections

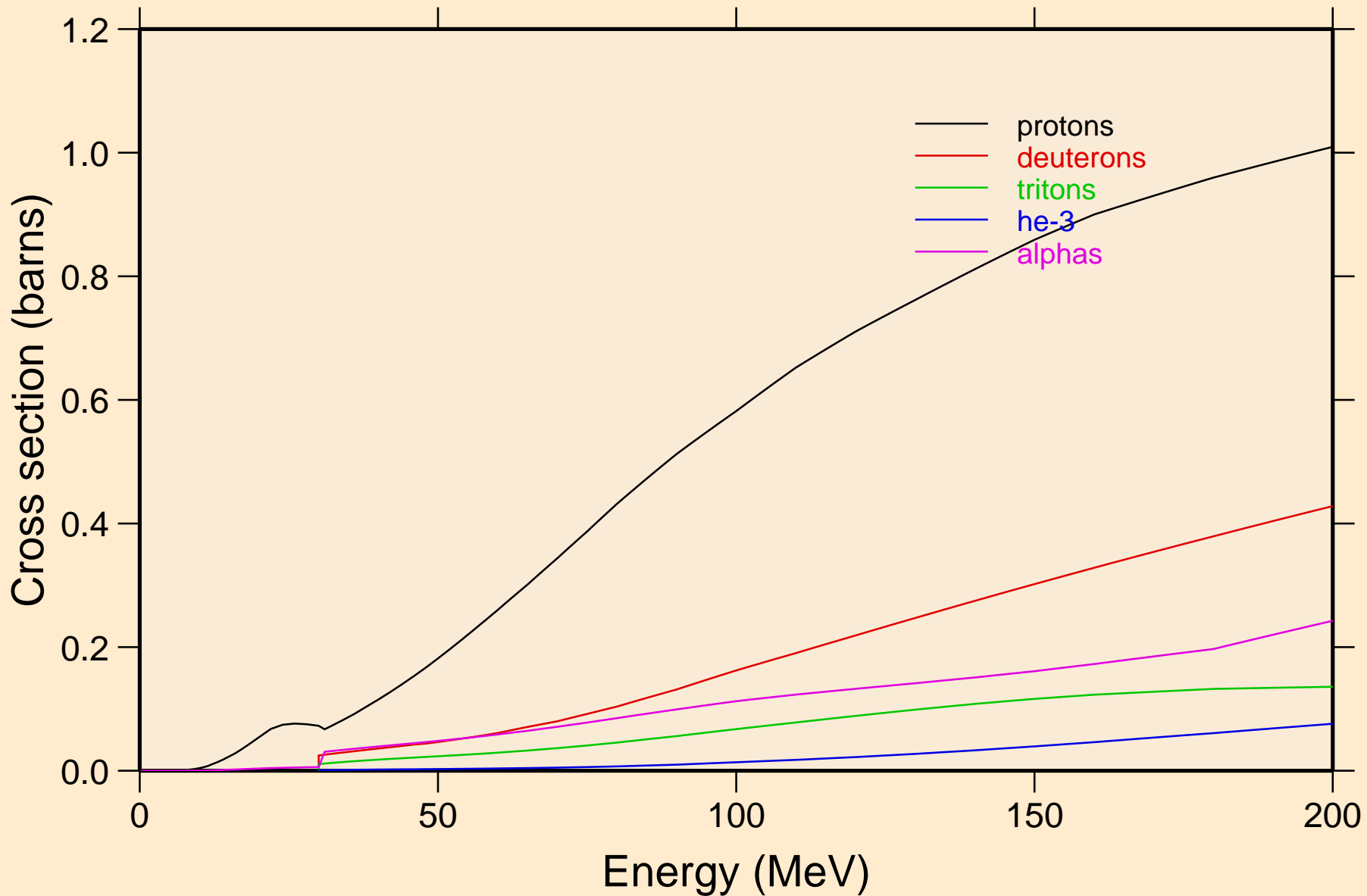

53-I-127 FOR FENDL-3.1 FROM FENDL-3.1 WITH NJOY2012.50+ C  
protons from (n,x)

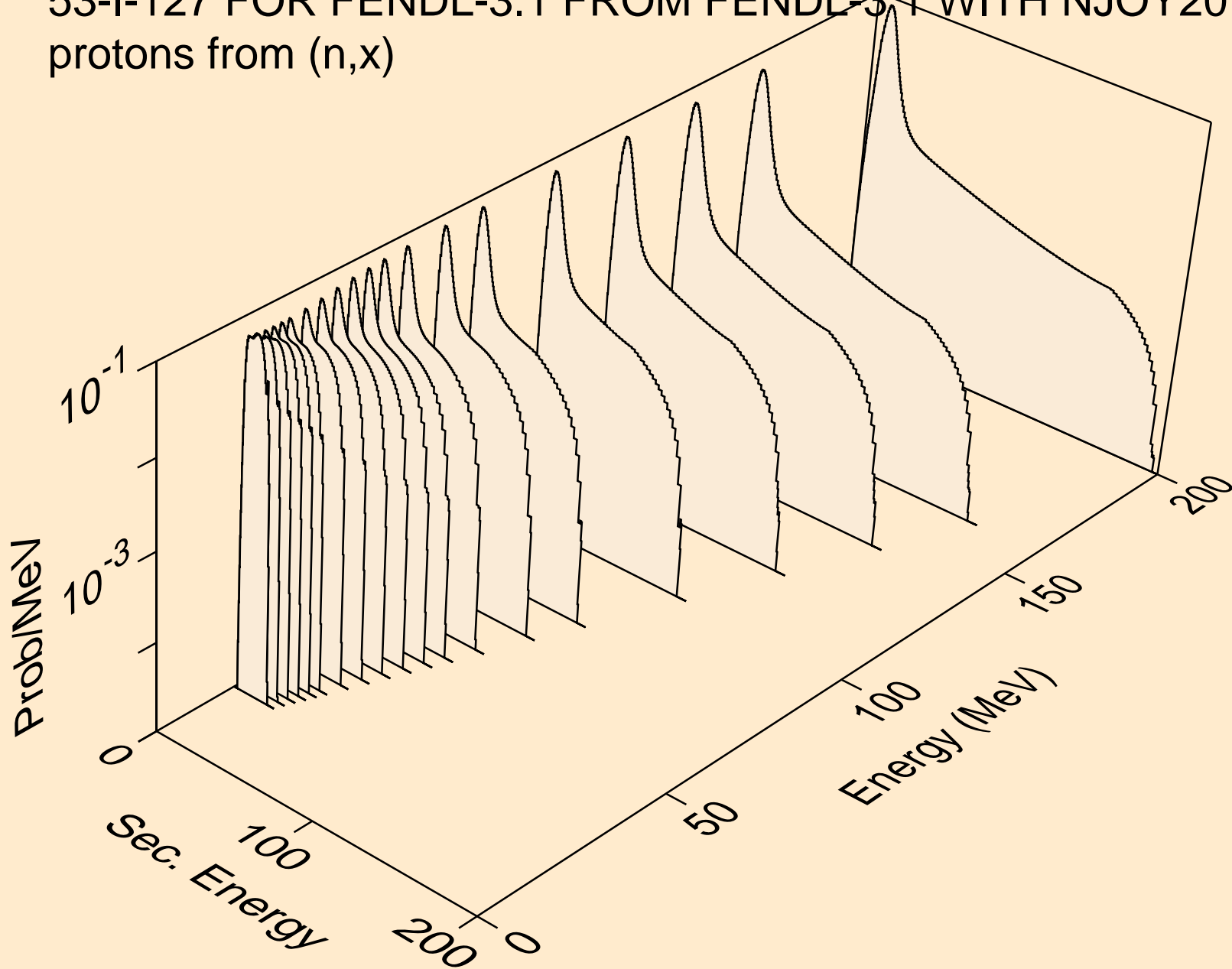

53-I-127 FOR FENDL-3.1 FROM FENDL-3.1 WITH NJOY2012.50+ C  
protons from (n,n\*)p

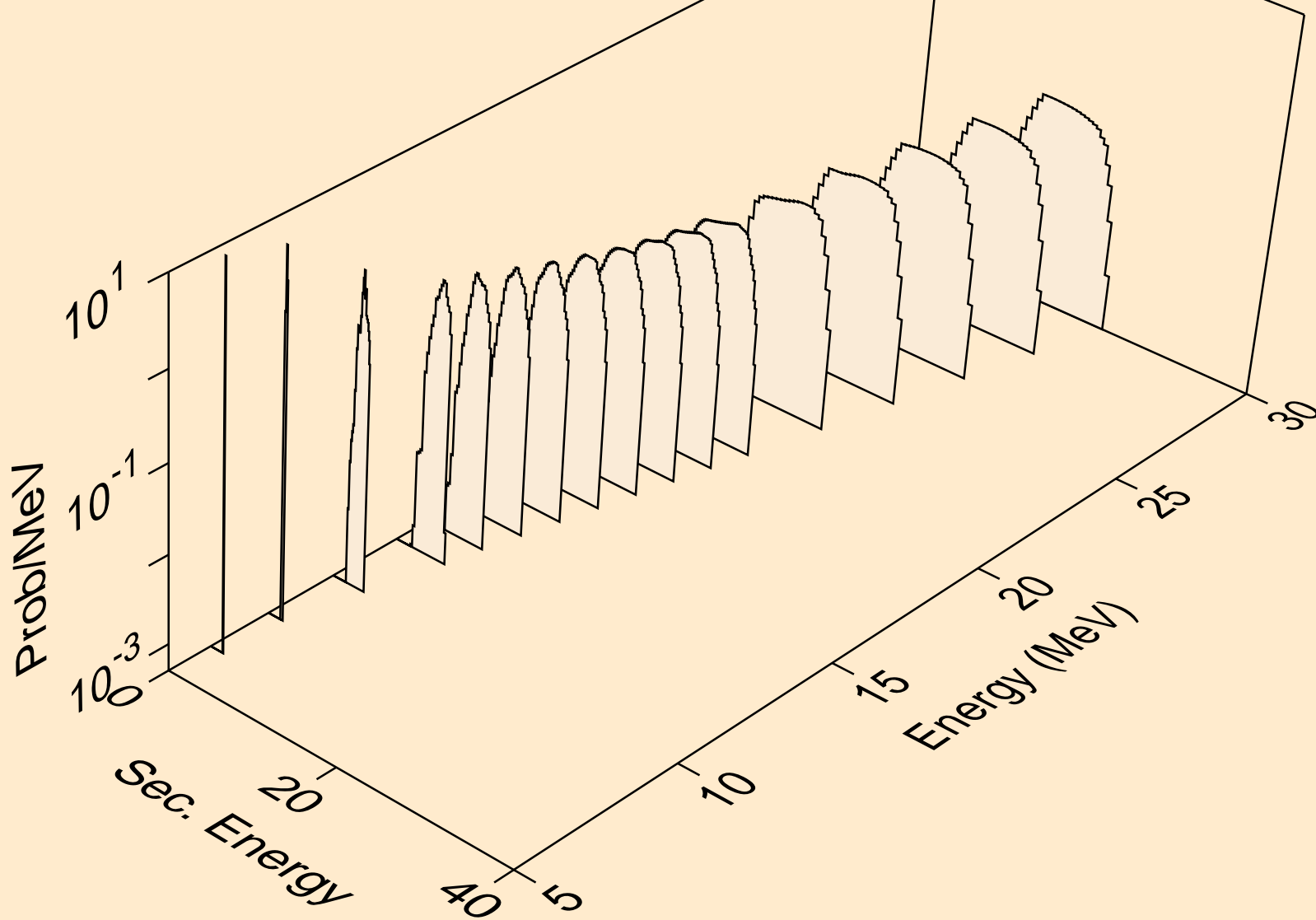

53-I-127 FOR FENDL-3.1 FROM FENDL-3.1 WITH NJOY2012.50+ C  
angular distribution for (n,p\*0) proton

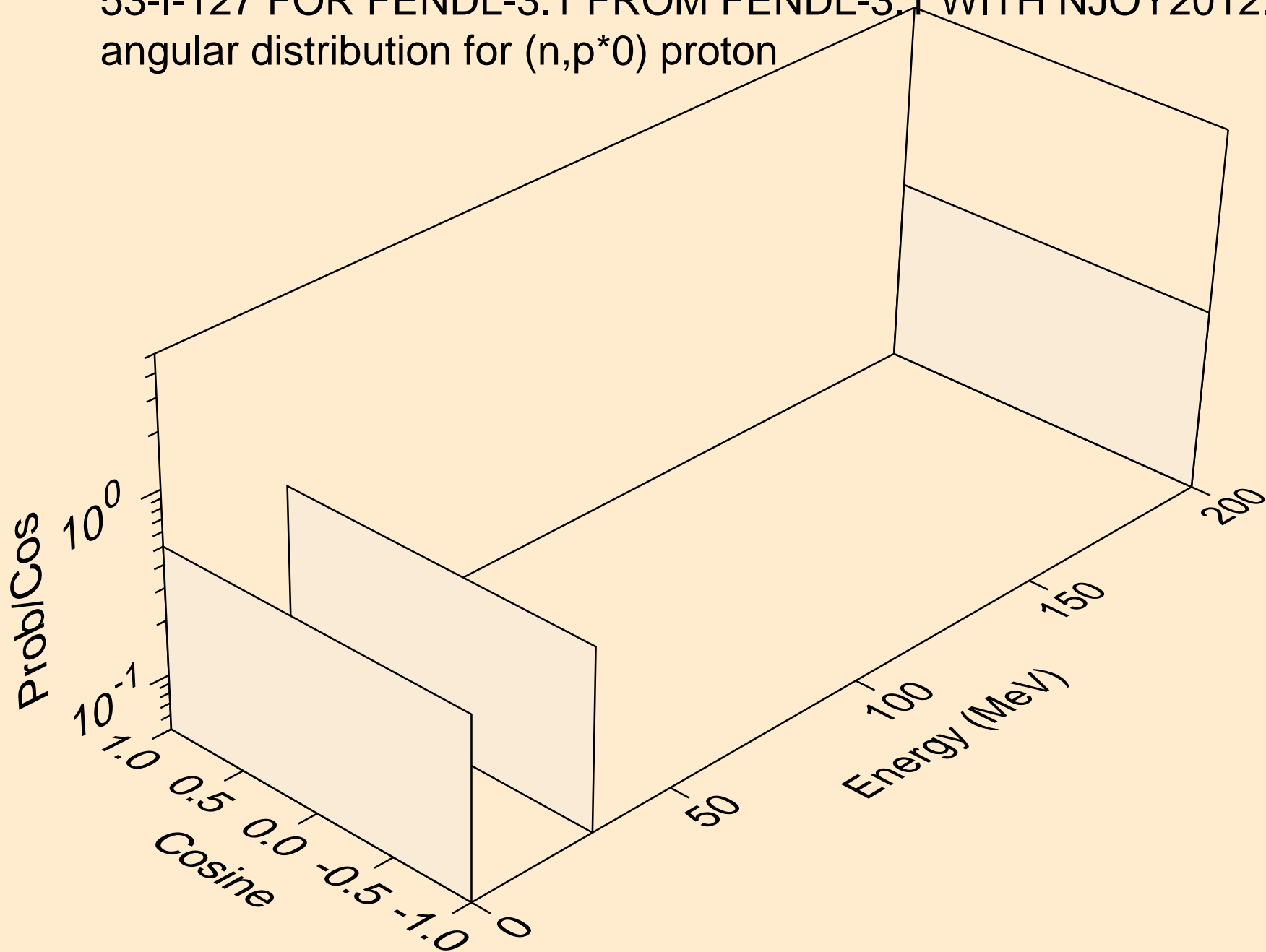



53-I-127 FOR FENDL-3.1 FROM FENDL-3.1 WITH NJOY2012.50+ C  
angular distribution for (n,p\*1) proton

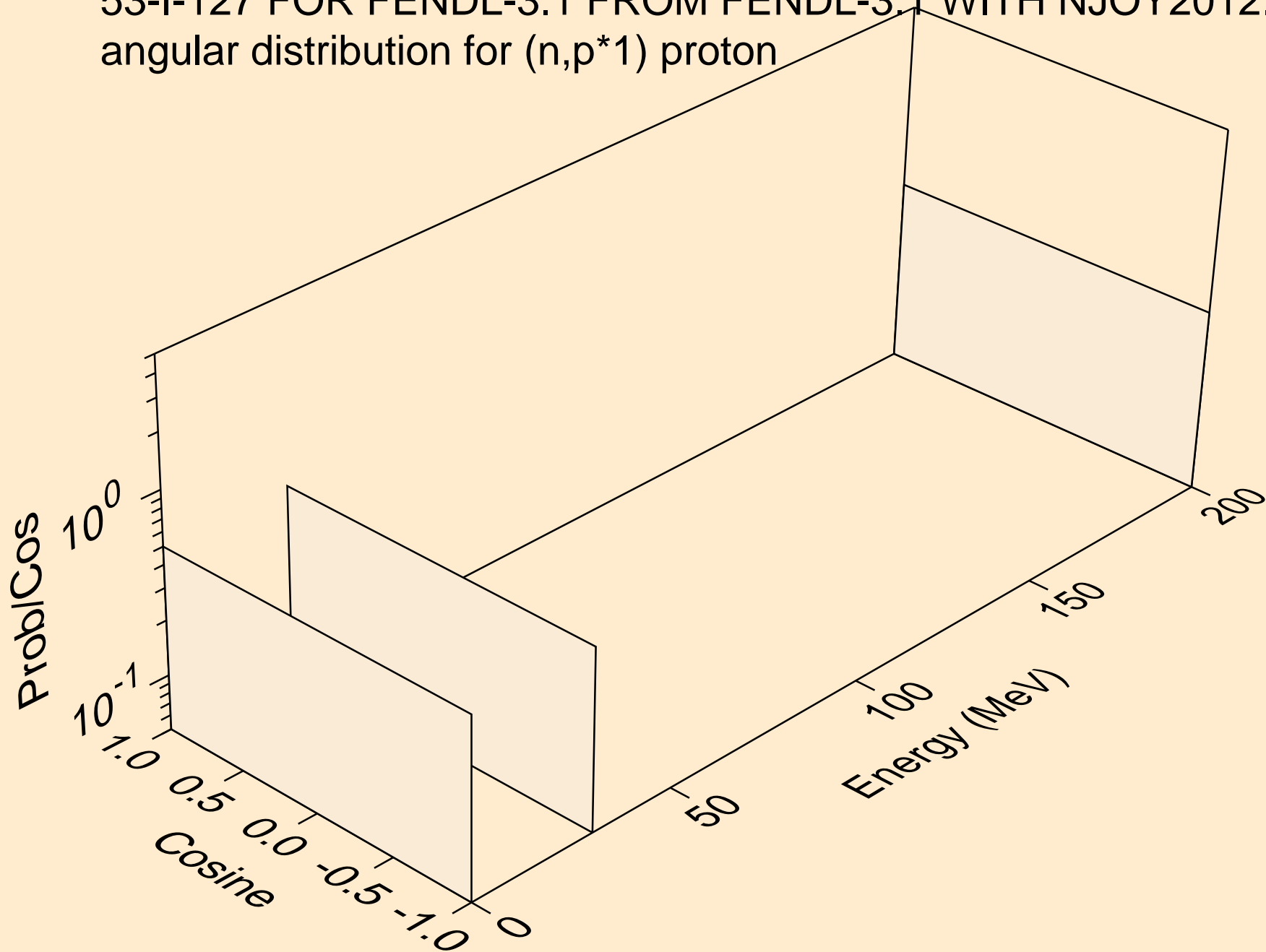

53-I-127 FOR FENDL-3.1 FROM FENDL-3.1 WITH NJOY2012.50+ C  
angular distribution for (n,p\*2) proton

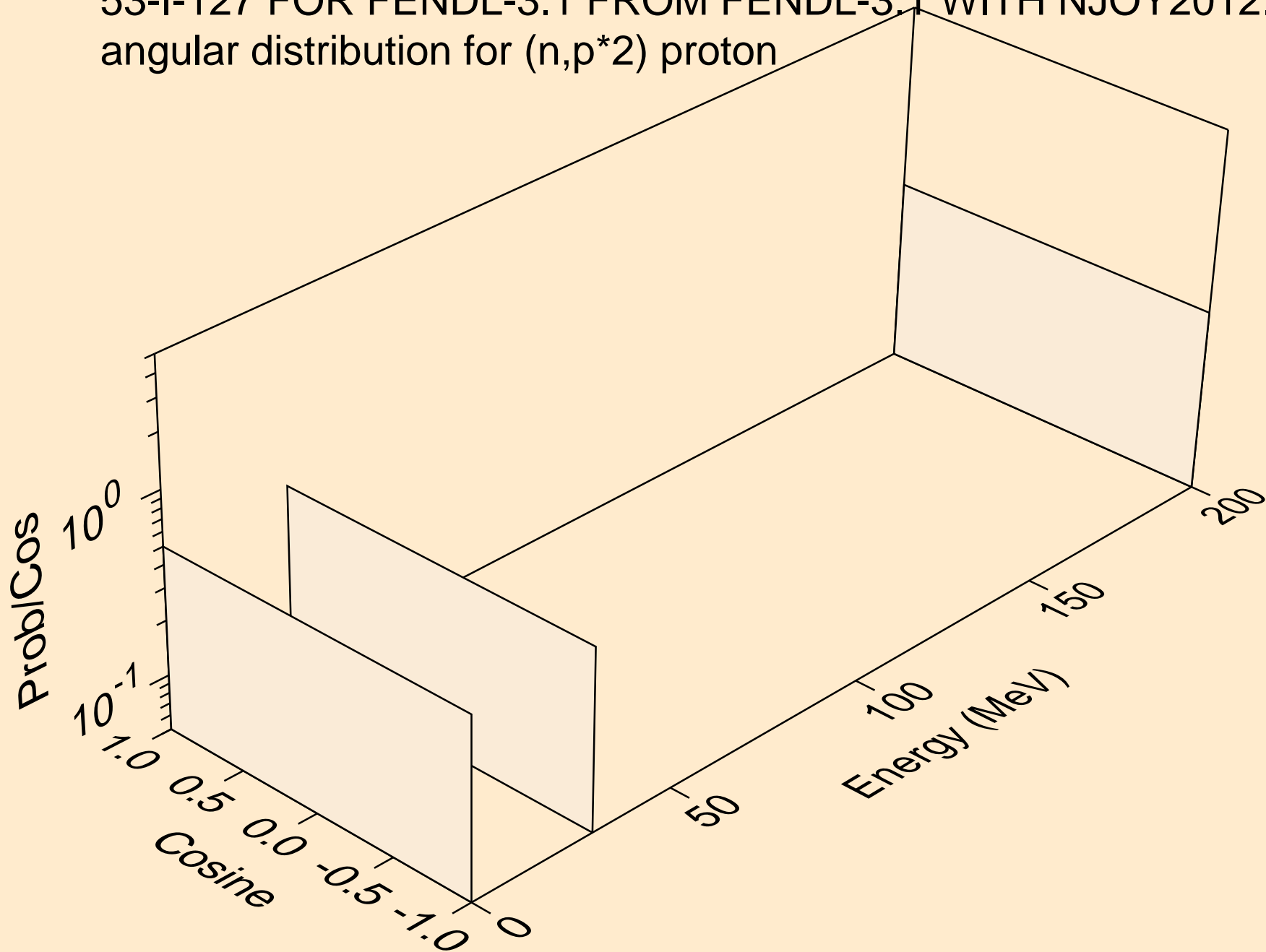

53-I-127 FOR FENDL-3.1 FROM FENDL-3.1 WITH NJOY2012.50+ C  
angular distribution for (n,p\*3) proton

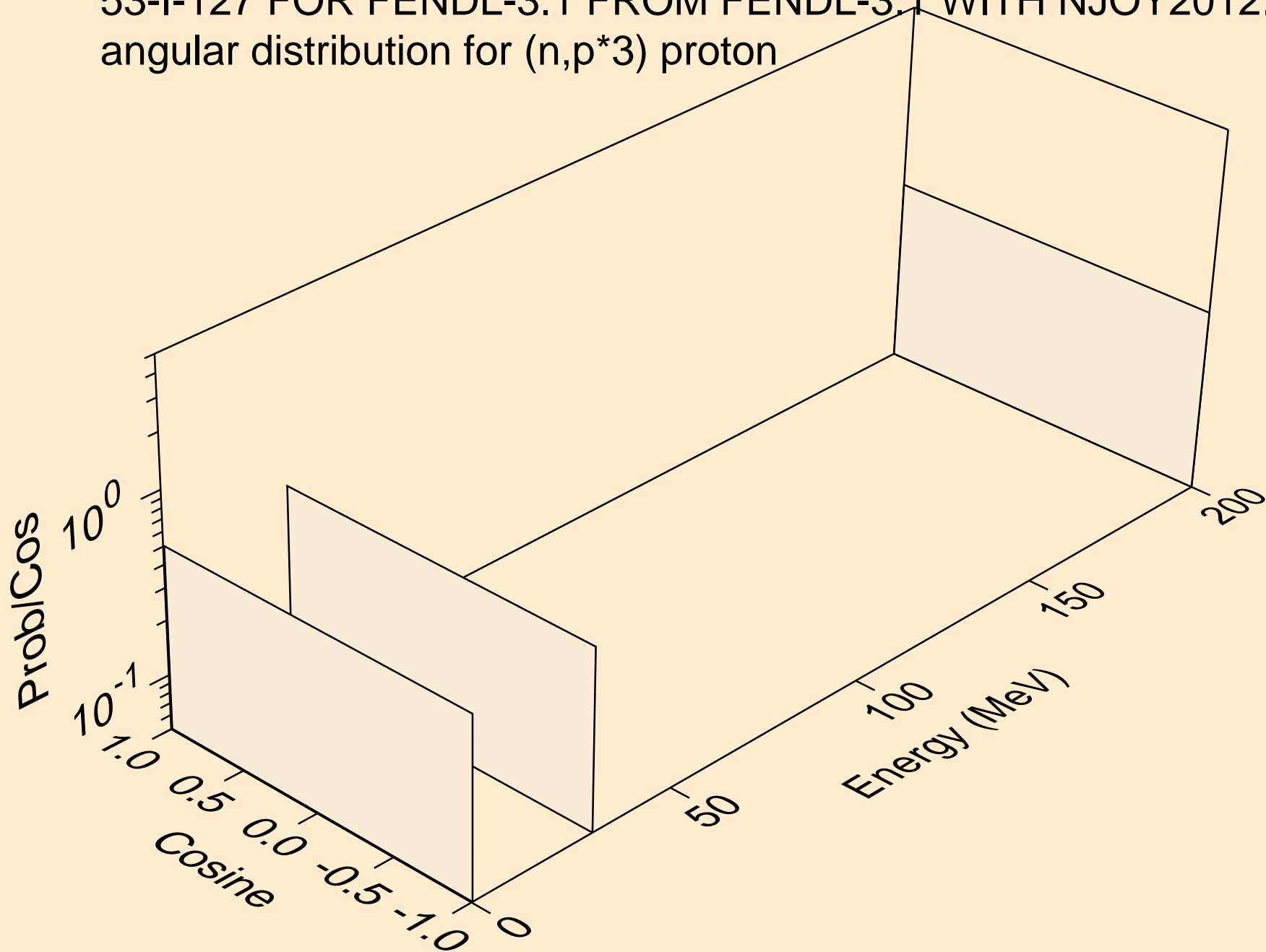

53-I-127 FOR FENDL-3.1 FROM FENDL-3.1 WITH NJOY2012.50+ C  
angular distribution for (n,p\*4) proton

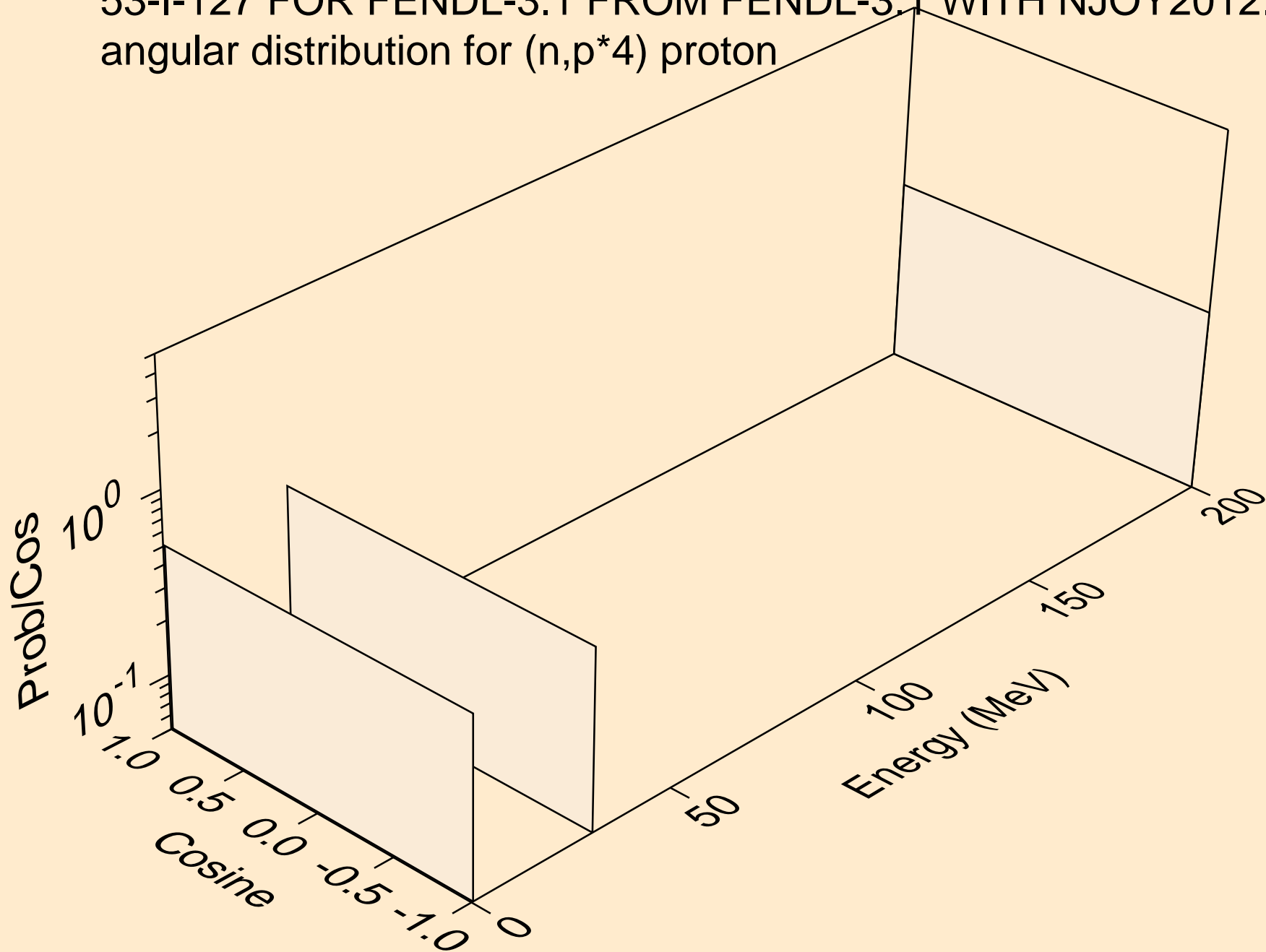

53-I-127 FOR FENDL-3.1 FROM FENDL-3.1 WITH NJOY2012.50+ C  
angular distribution for (n,p\*5) proton

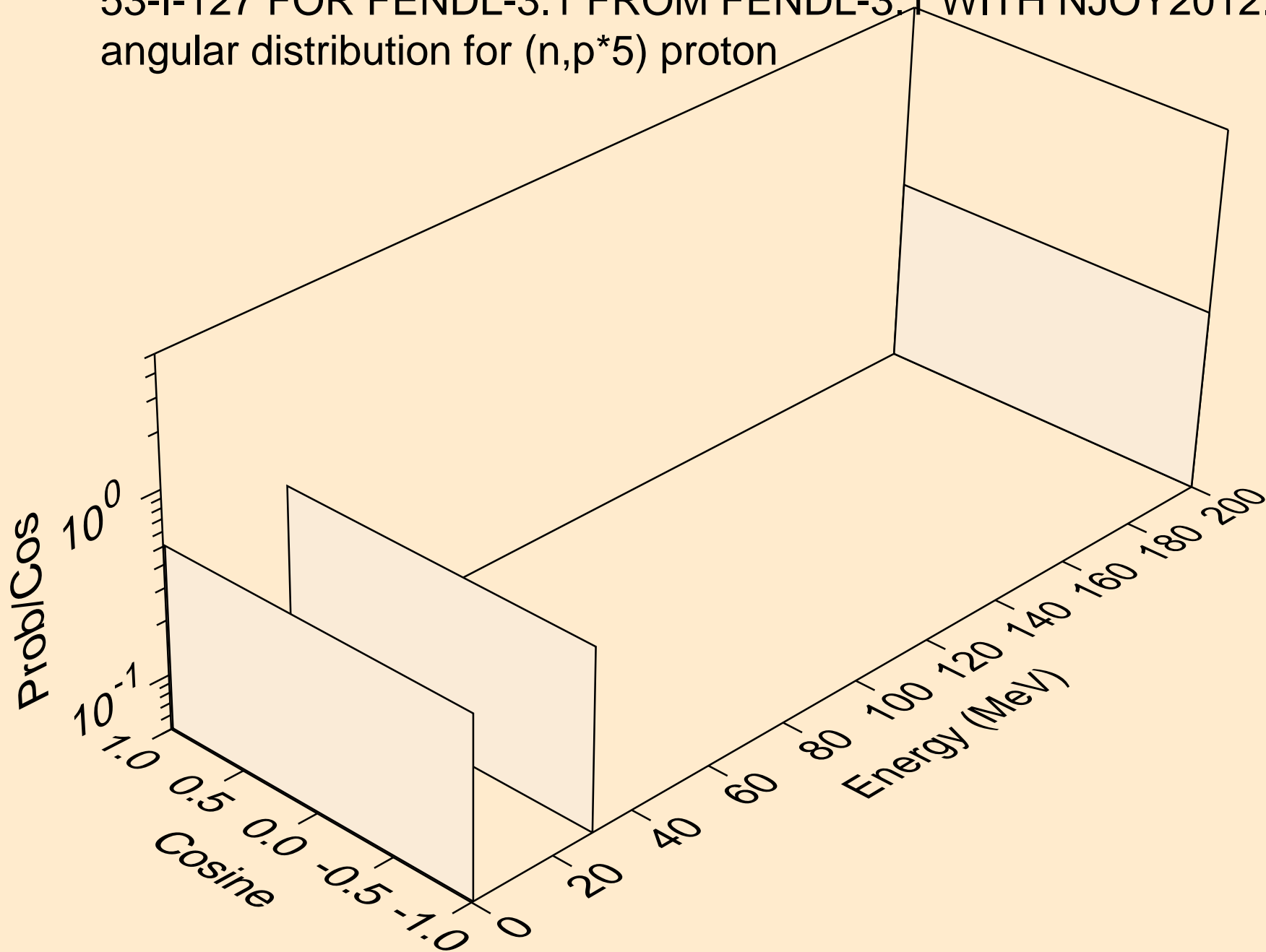

53-I-127 FOR FENDL-3.1 FROM FENDL-3.1 WITH NJOY2012.50+ C  
angular distribution for (n,p\*6) proton

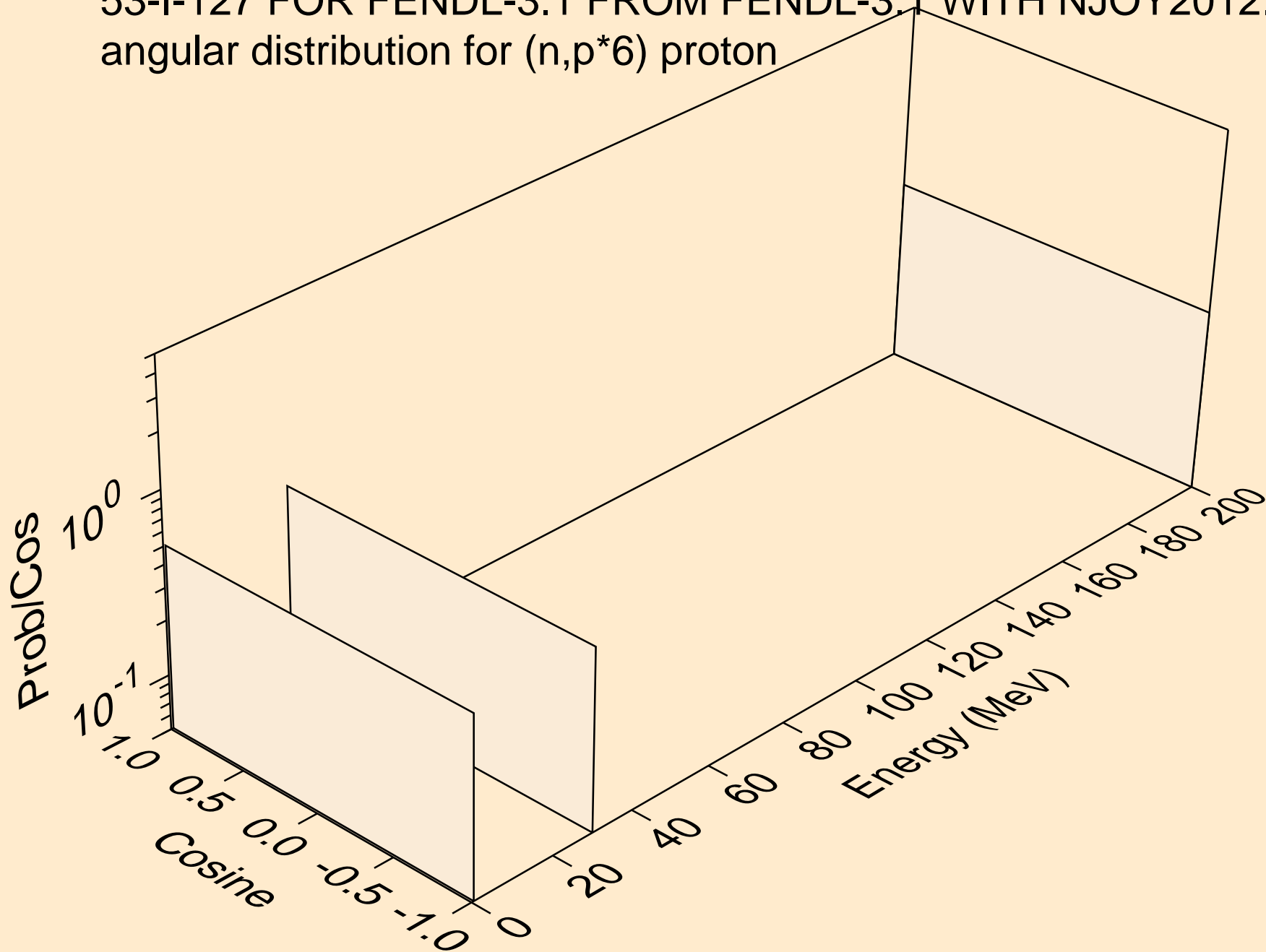

53-I-127 FOR FENDL-3.1 FROM FENDL-3.1 WITH NJOY2012.50+ C  
angular distribution for (n,p\*7) proton

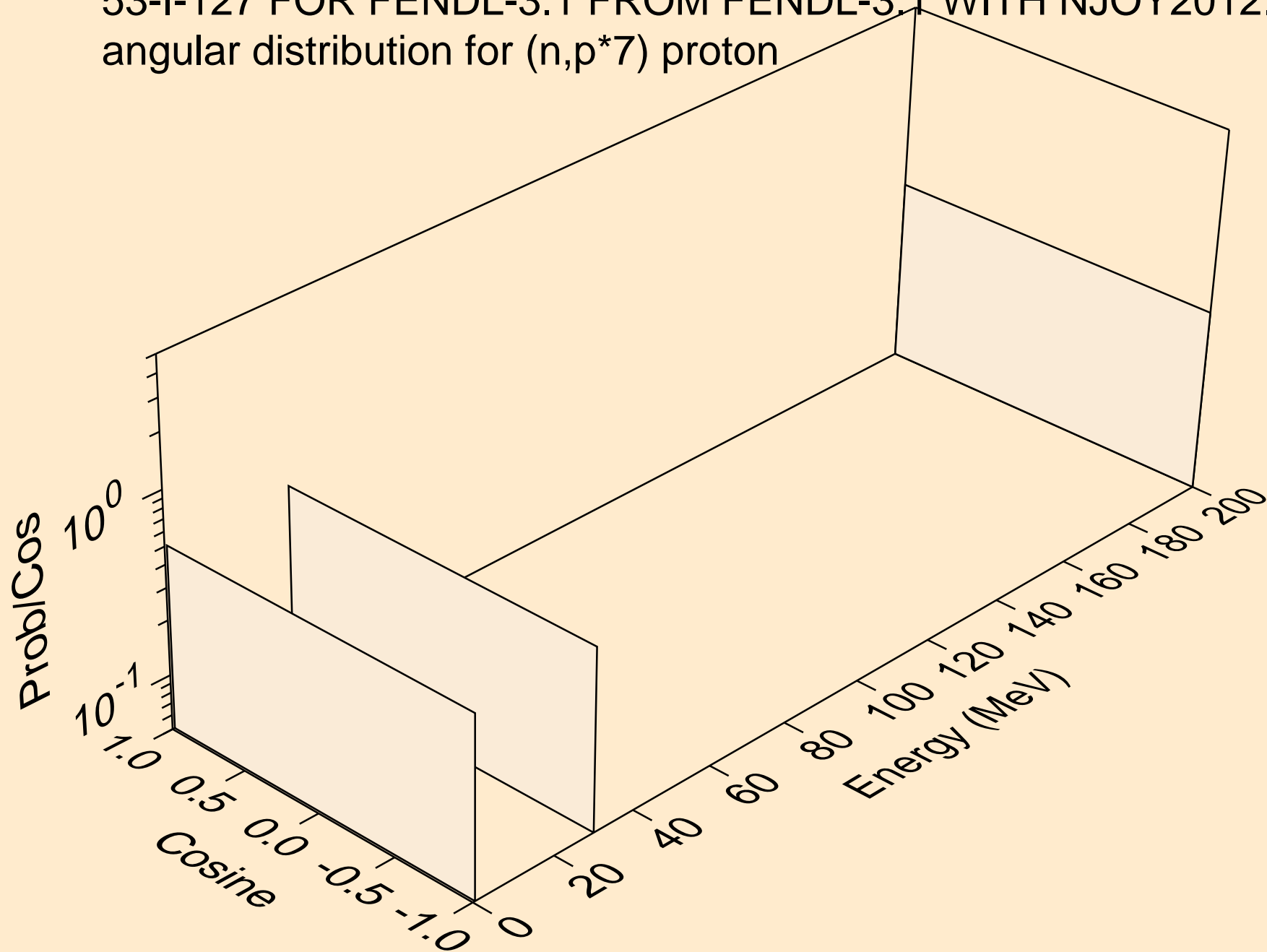

53-I-127 FOR FENDL-3.1 FROM FENDL-3.1 WITH NJOY2012.50+ C  
angular distribution for (n,p\*8) proton

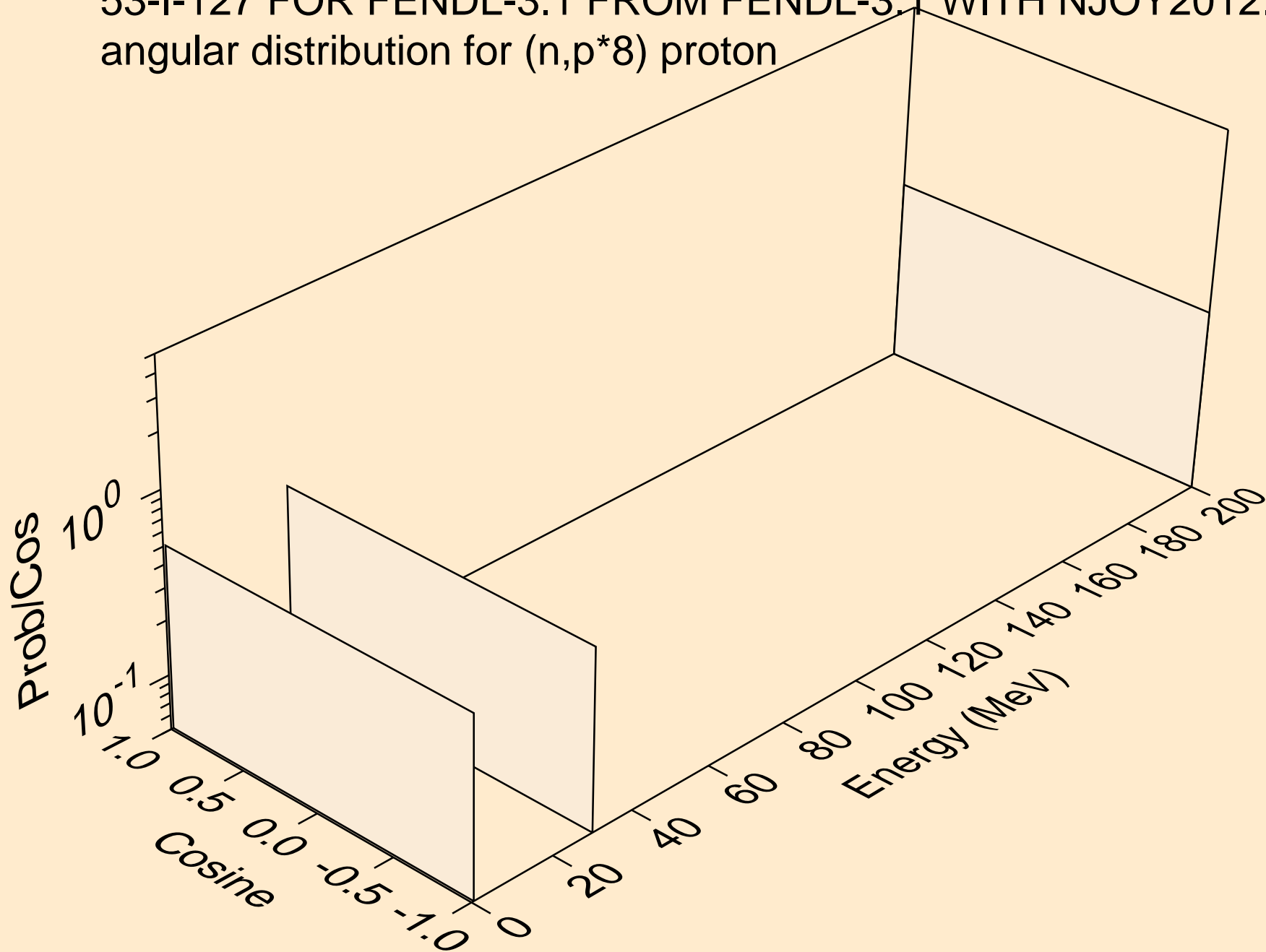



53-I-127 FOR FENDL-3.1 FROM FENDL-3.1 WITH NJOY2012.50+ C  
angular distribution for (n,p\*9) proton

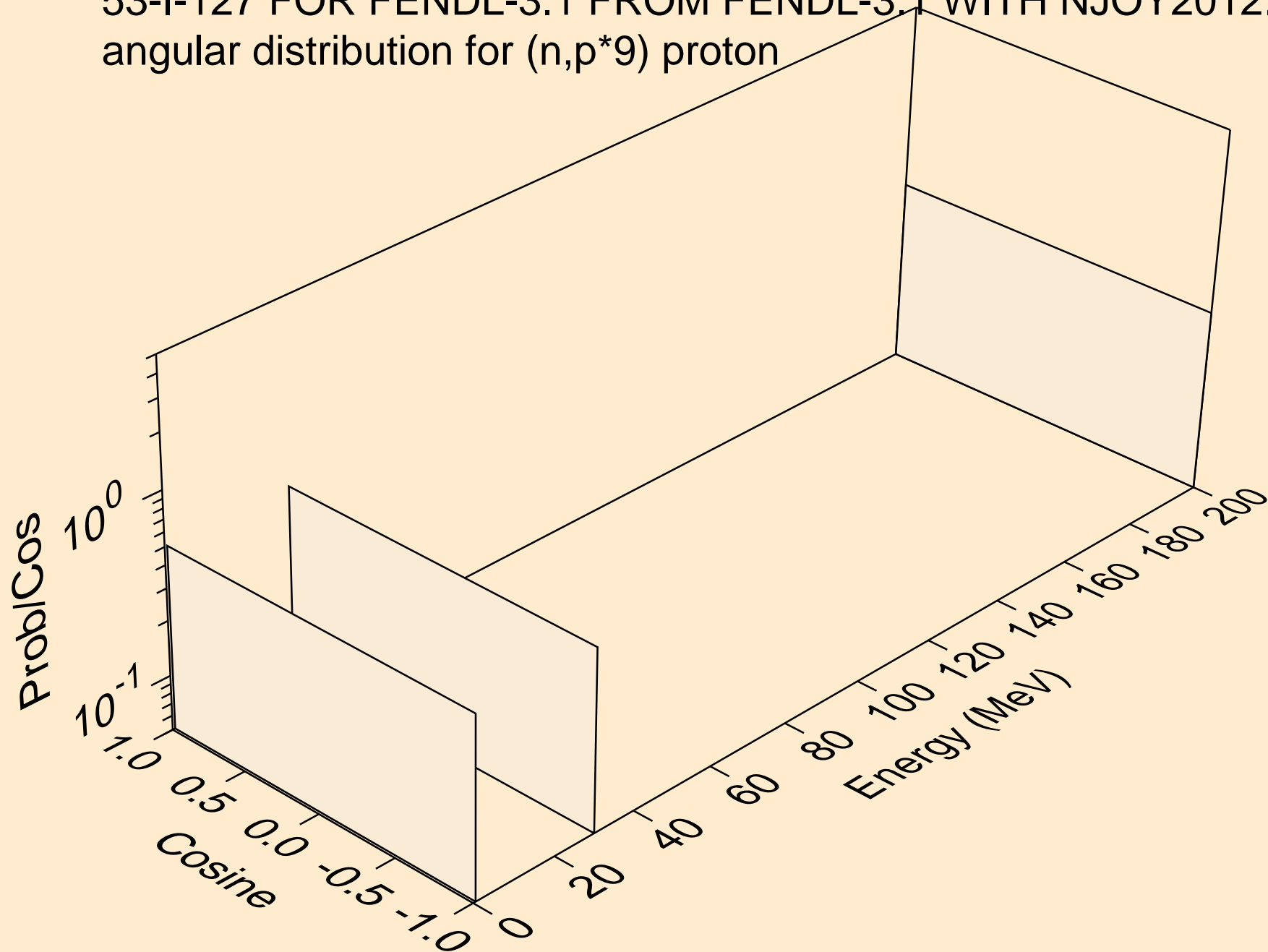

53-I-127 FOR FENDL-3.1 FROM FENDL-3.1 WITH NJOY2012.50+ C  
angular distribution for (n,p\*10) proton

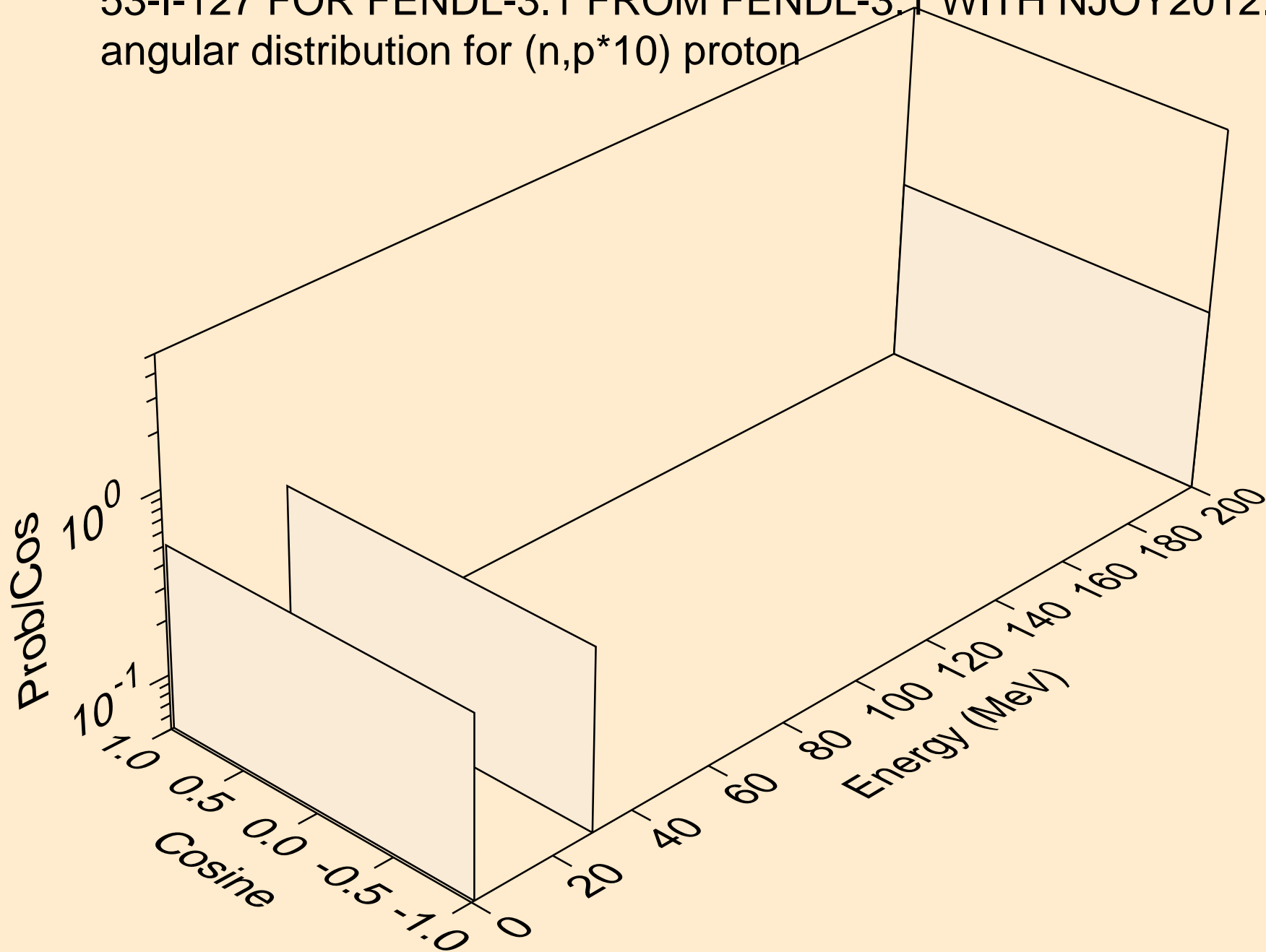

53-I-127 FOR FENDL-3.1 FROM FENDL-3.1 WITH NJOY2012.50+ C  
angular distribution for (n,p\*11) proton

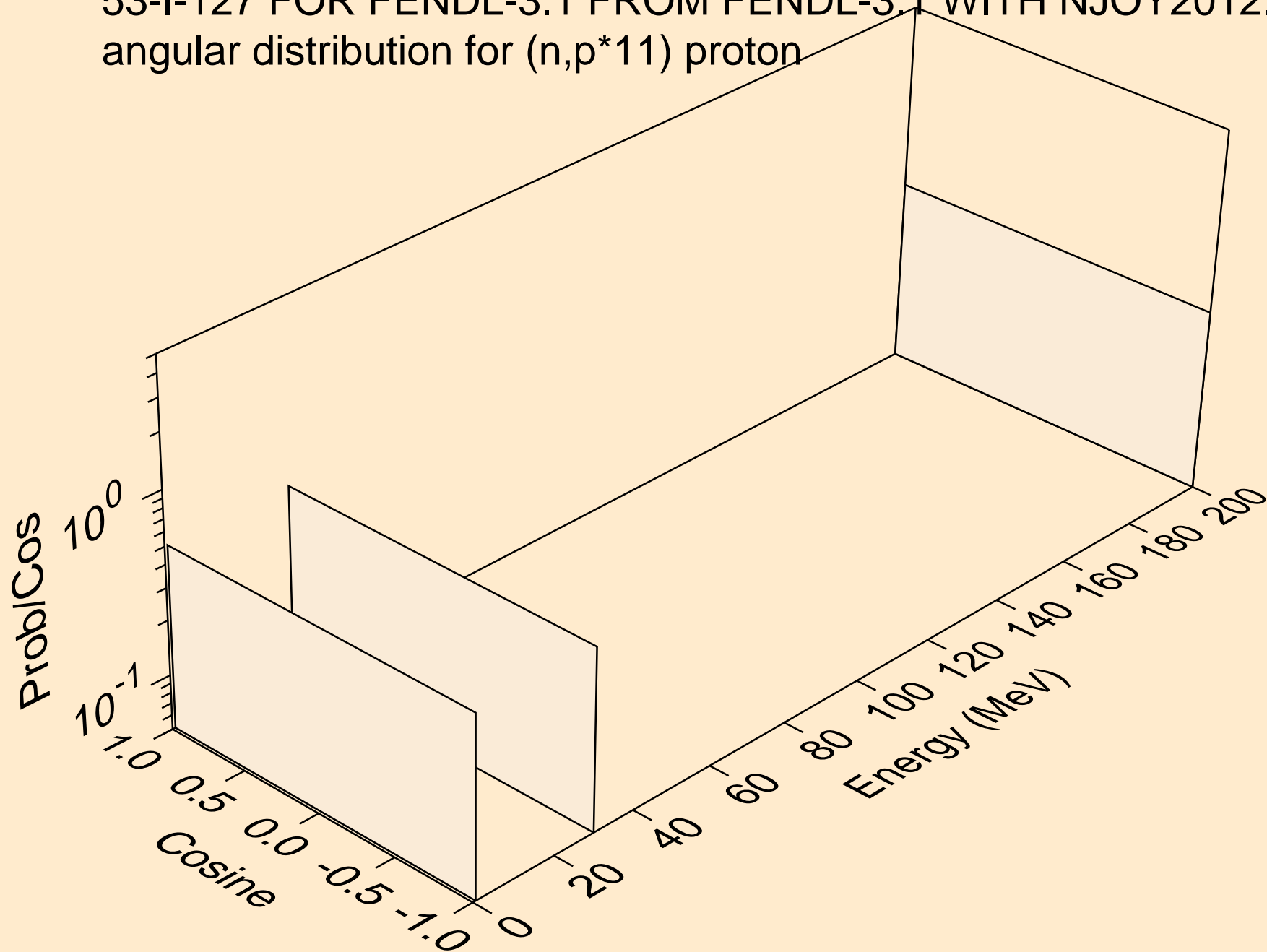

53-I-127 FOR FENDL-3.1 FROM FENDL-3.1 WITH NJOY2012.50+ C  
angular distribution for (n,p\*12) proton

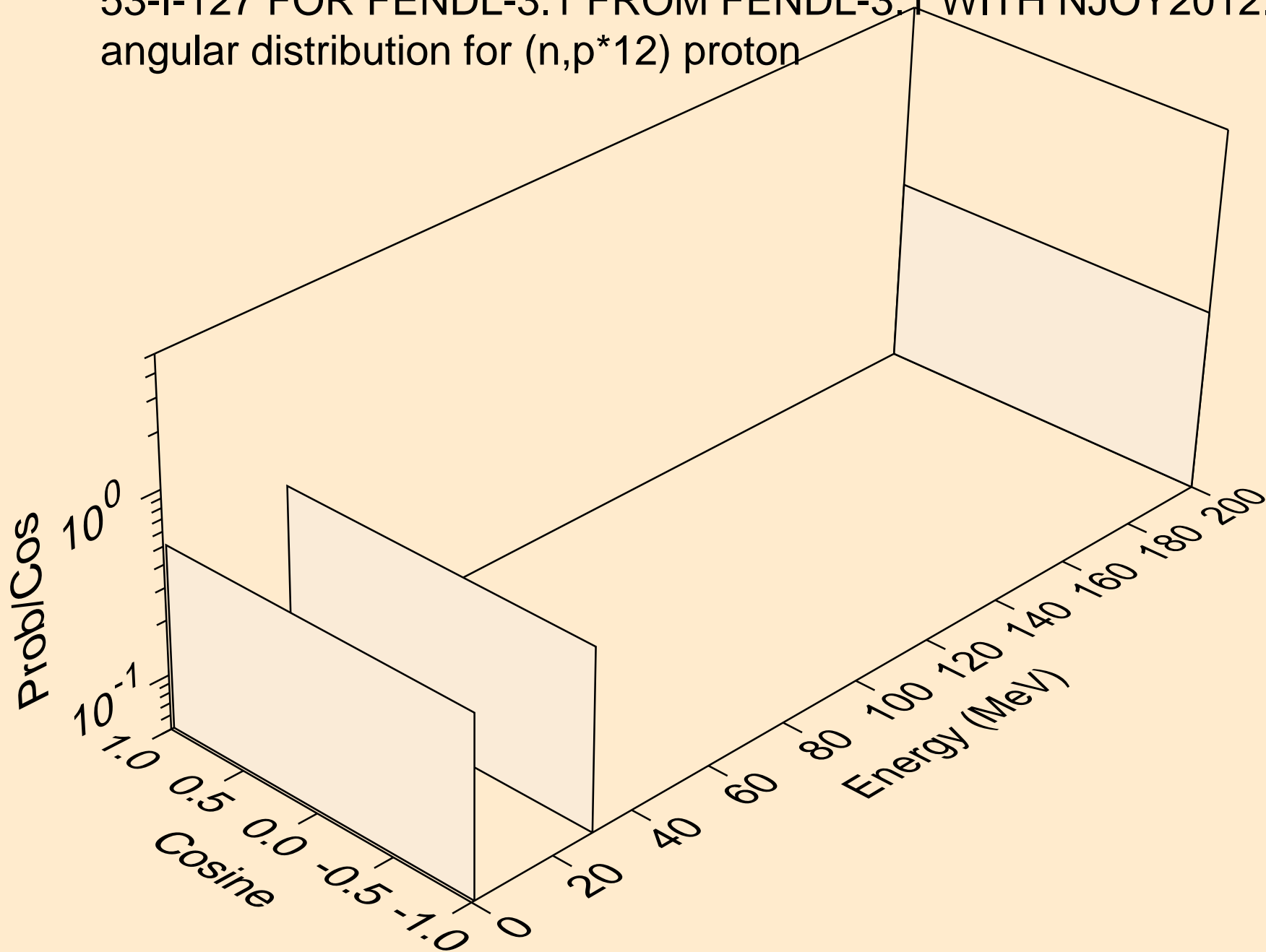

53-I-127 FOR FENDL-3.1 FROM FENDL-3.1 WITH NJOY2012.50+ C  
angular distribution for (n,p\*13) proton

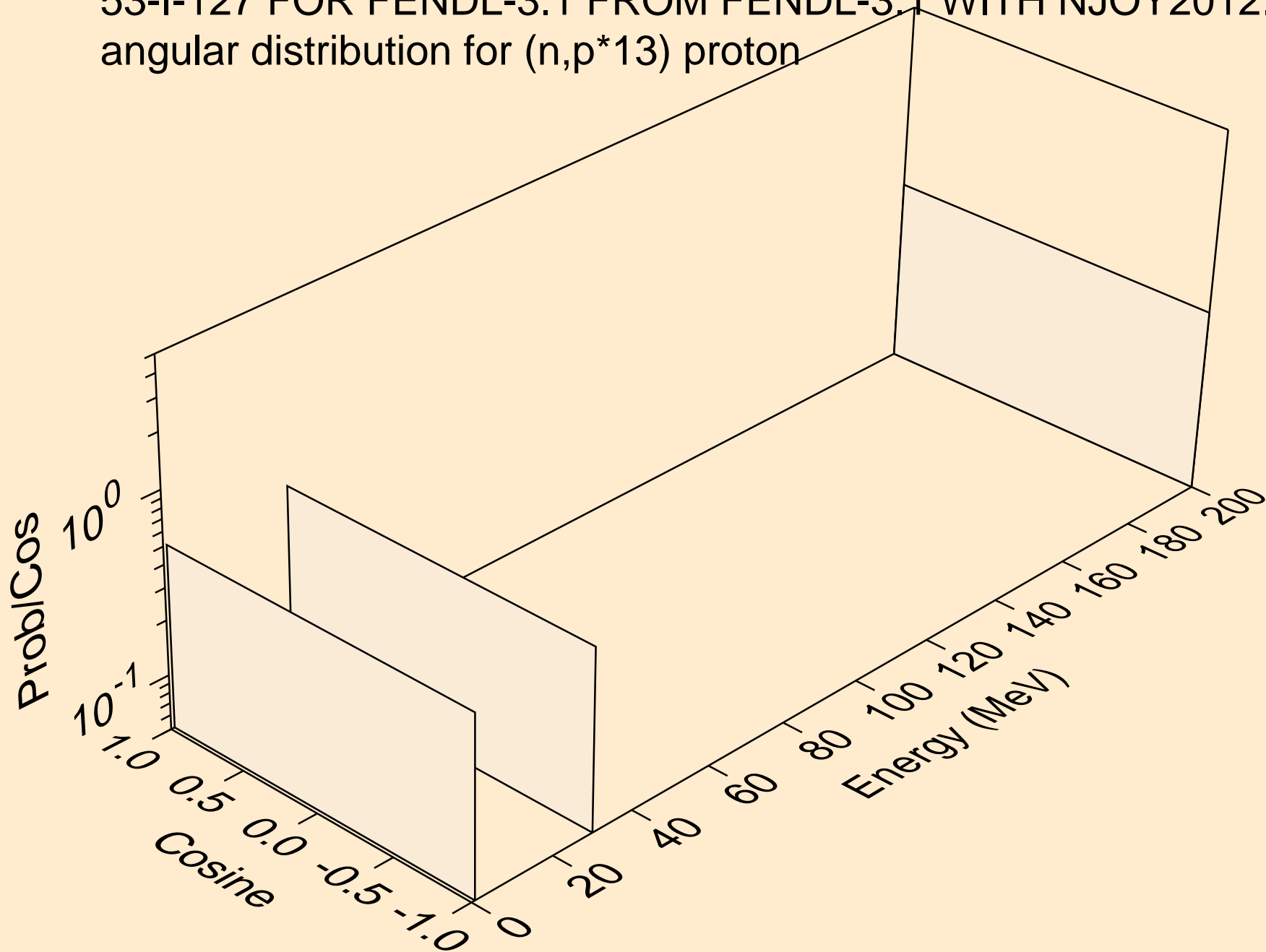

53-I-127 FOR FENDL-3.1 FROM FENDL-3.1 WITH NJOY2012.50+ C  
angular distribution for (n,p\*14) proton

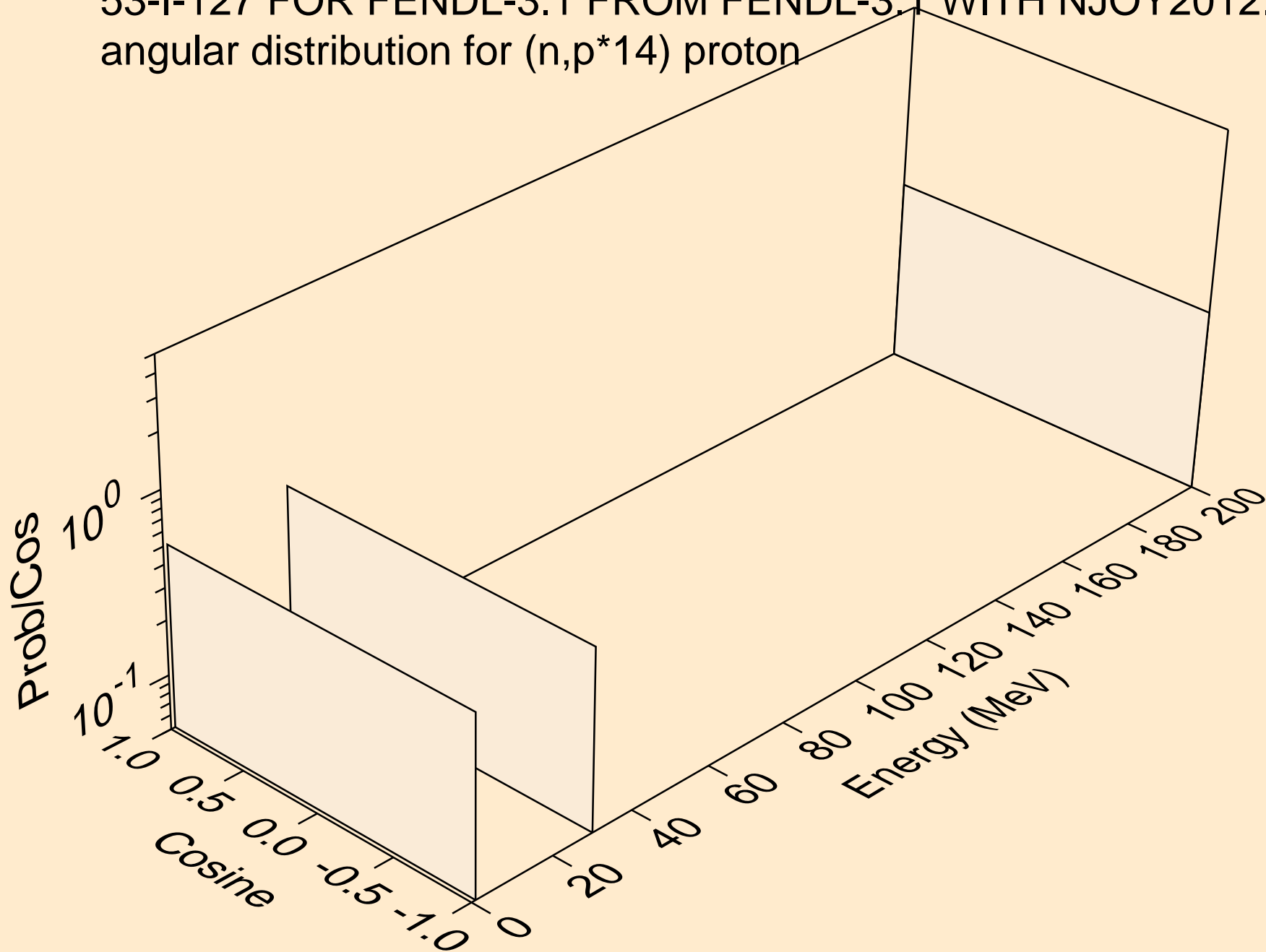

53-I-127 FOR FENDL-3.1 FROM FENDL-3.1 WITH NJOY2012.50+ C  
angular distribution for (n,p\*15) proton

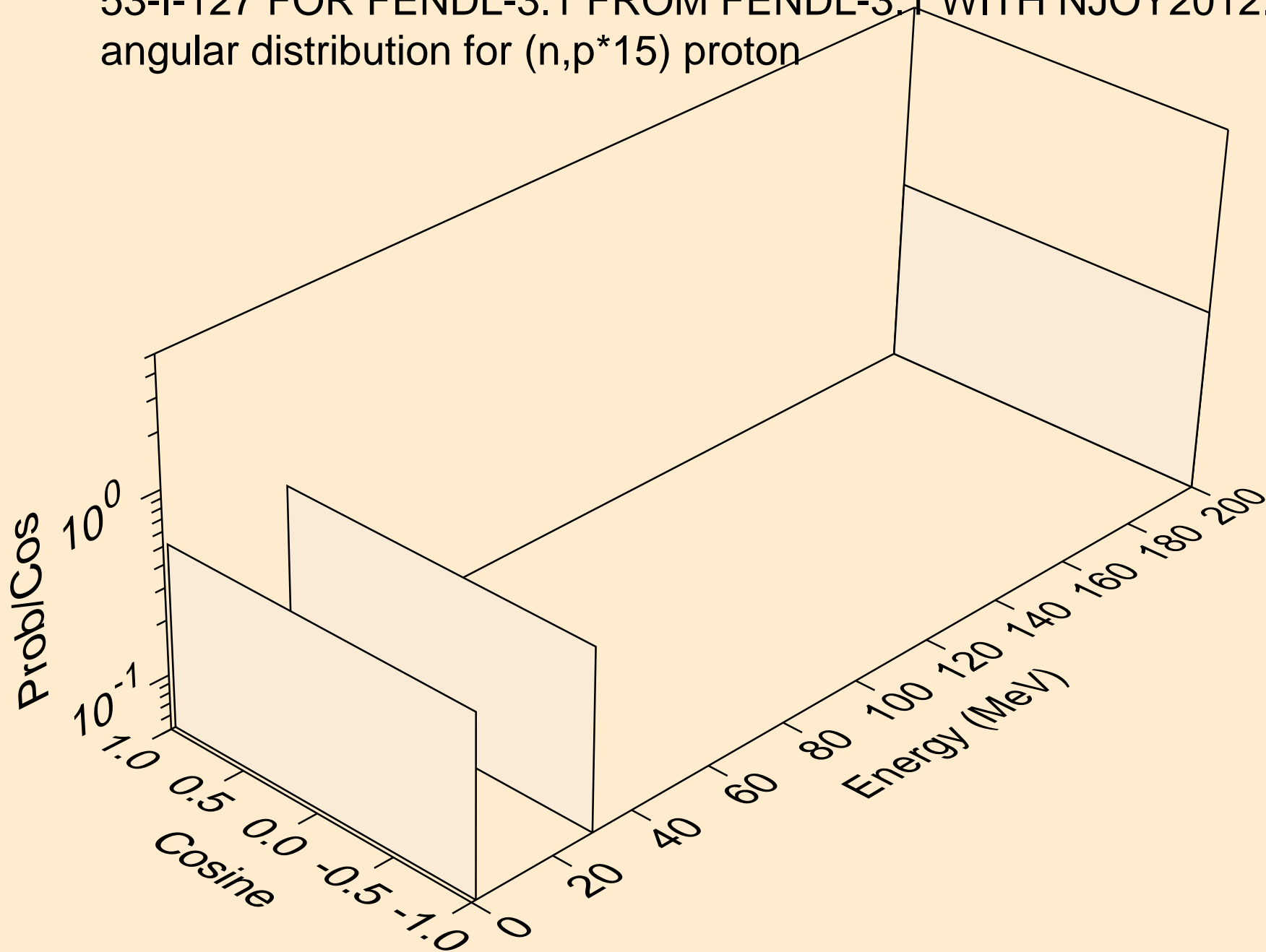

53-I-127 FOR FENDL-3.1 FROM FENDL-3.1 WITH NJOY2012.50+ C  
angular distribution for (n,p\*16) proton

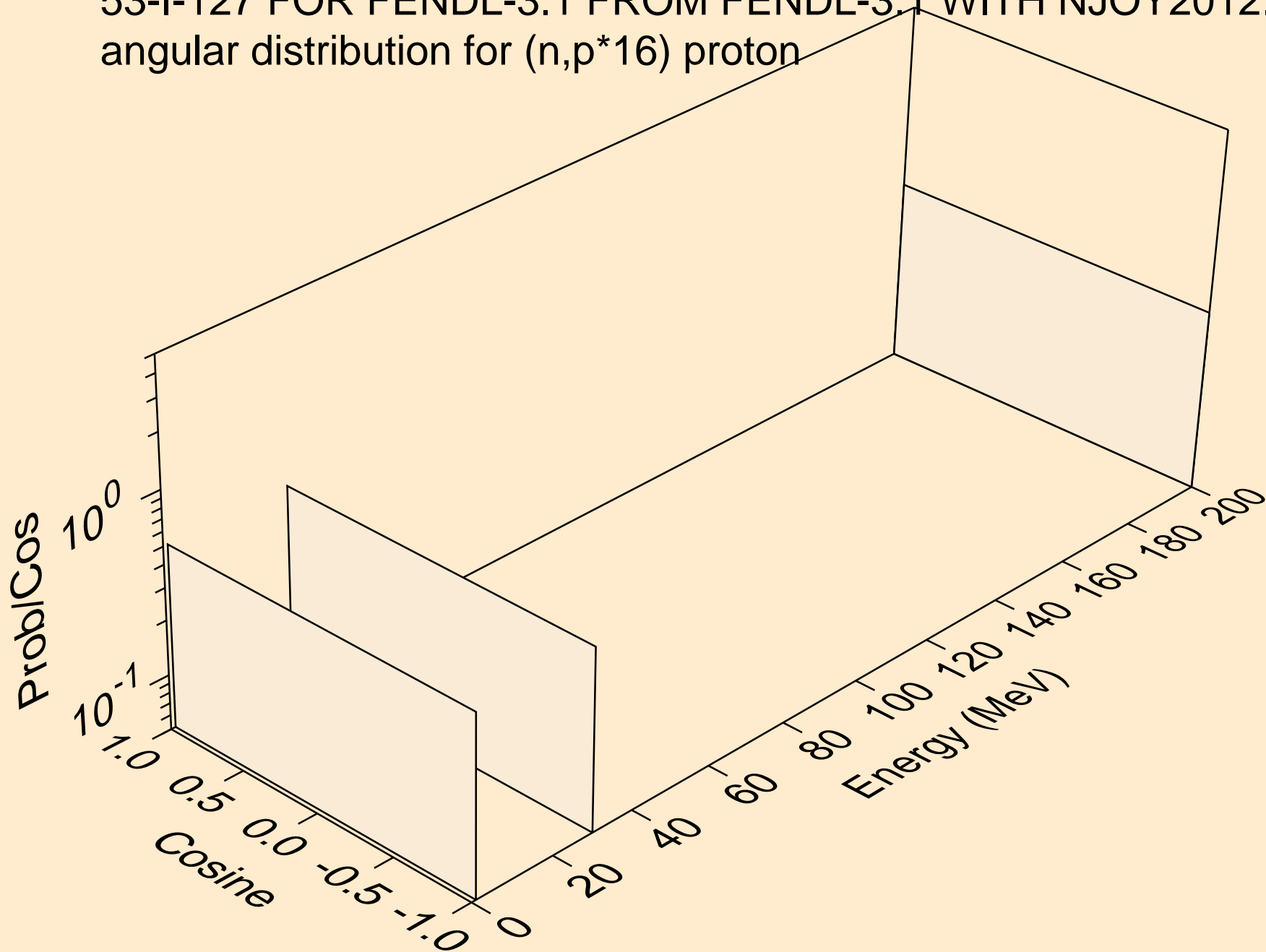



53-I-127 FOR FENDL-3.1 FROM FENDL-3.1 WITH NJOY2012.50+ C  
angular distribution for (n,p\*17) proton

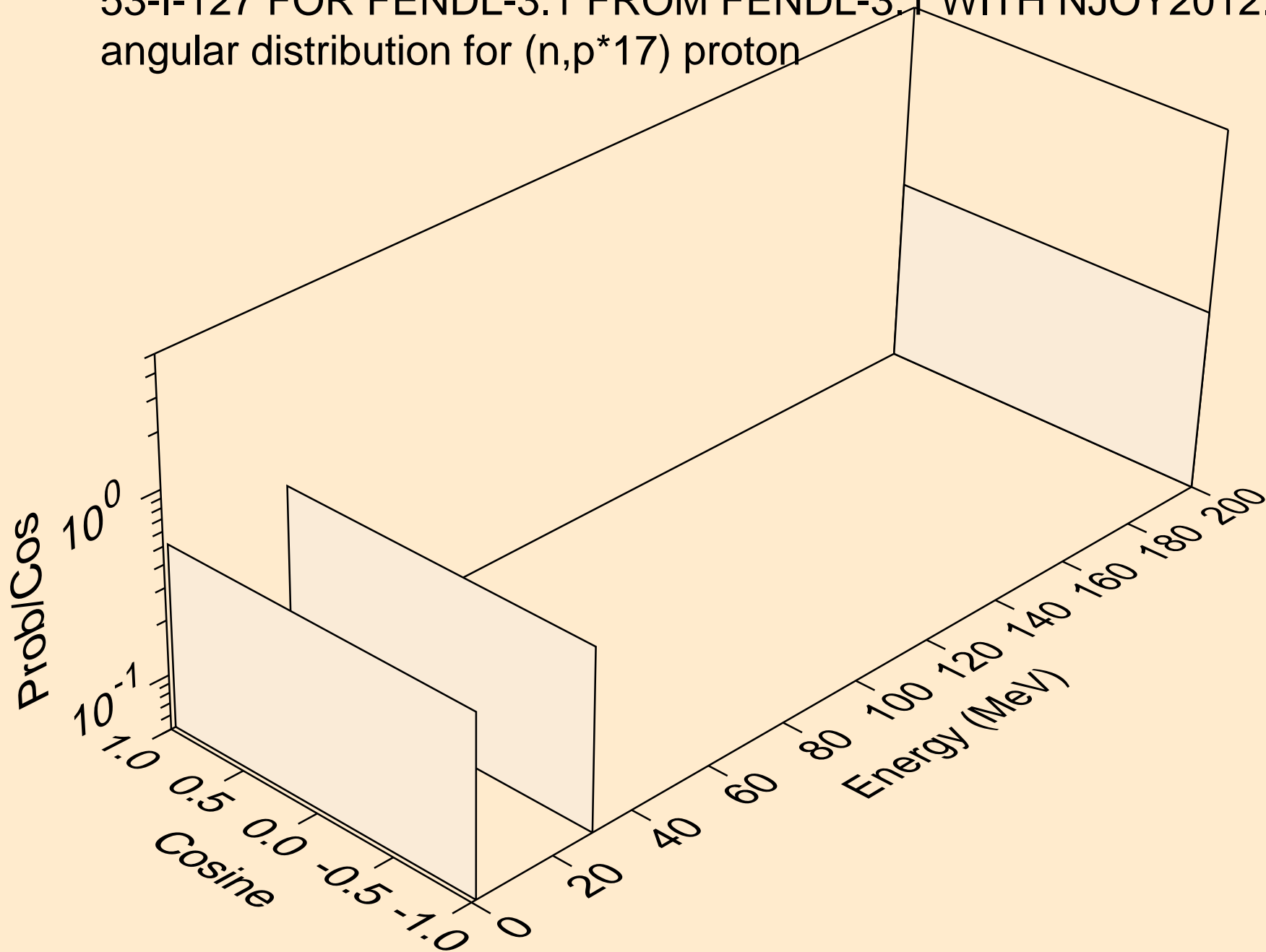

53-I-127 FOR FENDL-3.1 FROM FENDL-3.1 WITH NJOY2012.50+ C  
angular distribution for (n,p\*18) proton

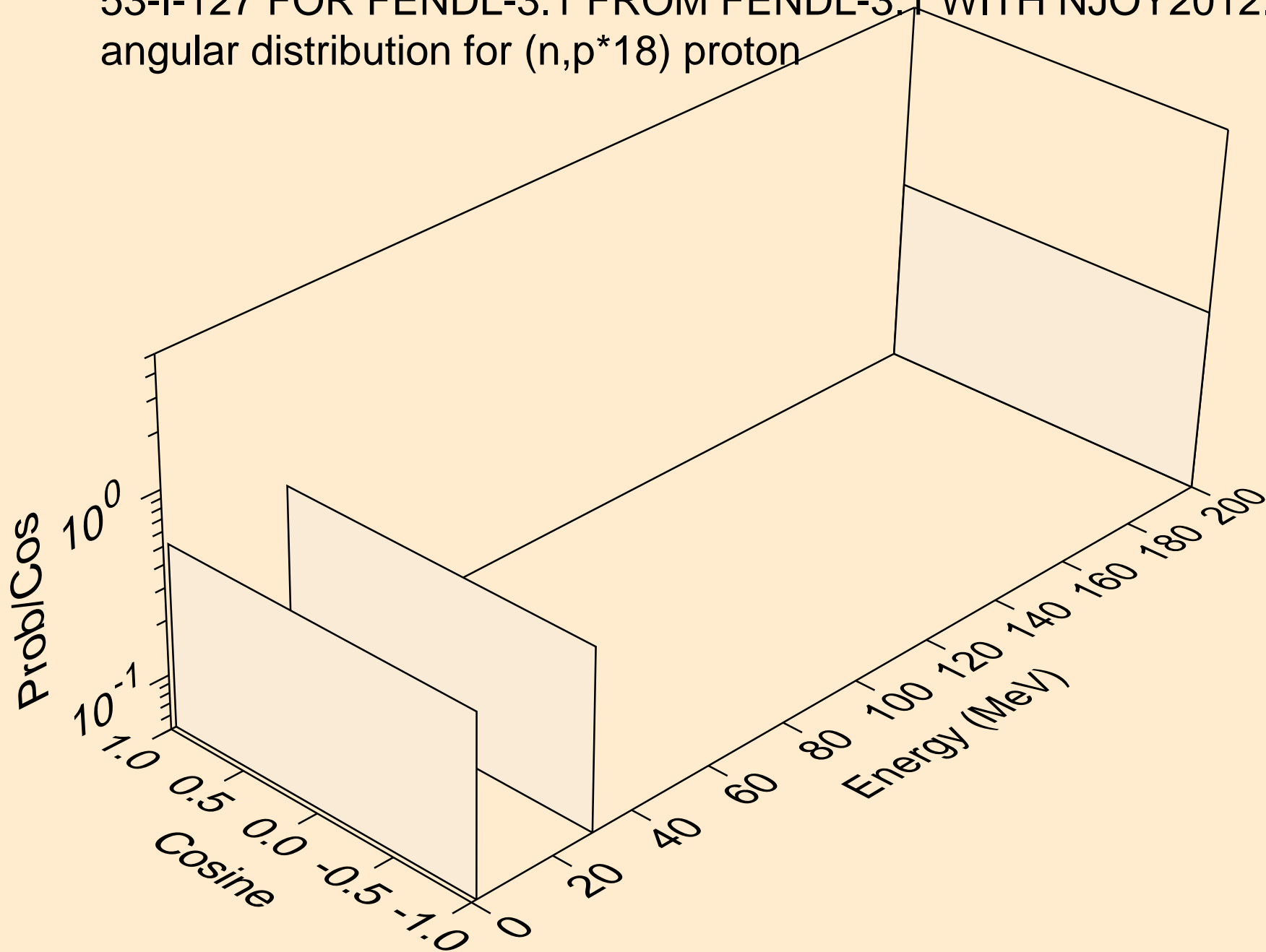

53-I-127 FOR FENDL-3.1 FROM FENDL-3.1 WITH NJOY2012.50+ C  
angular distribution for (n,p\*19) proton

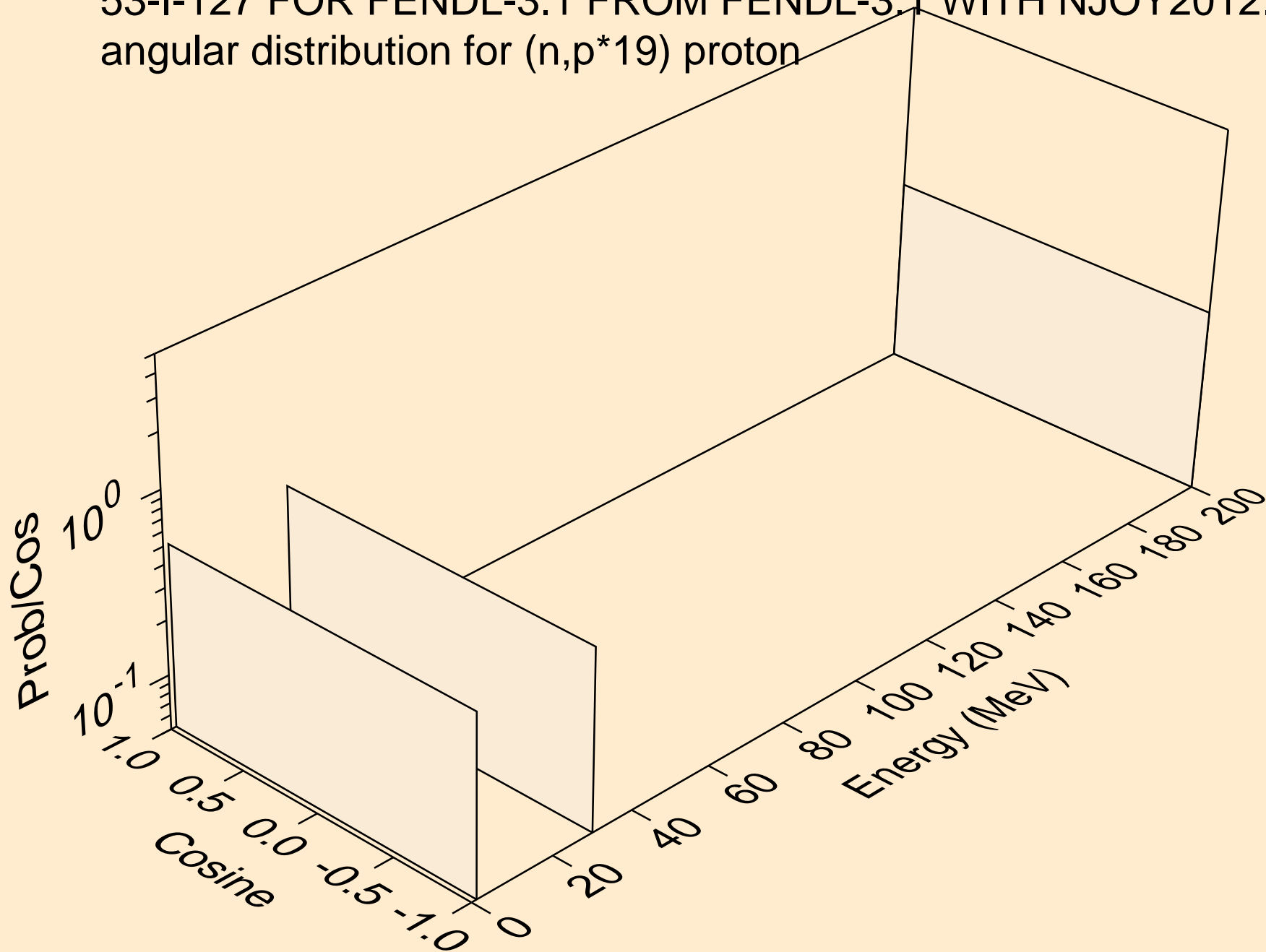

53-I-127 FOR FENDL-3.1 FROM FENDL-3.1 WITH NJOY2012.50+ C  
angular distribution for (n,p\*20) proton

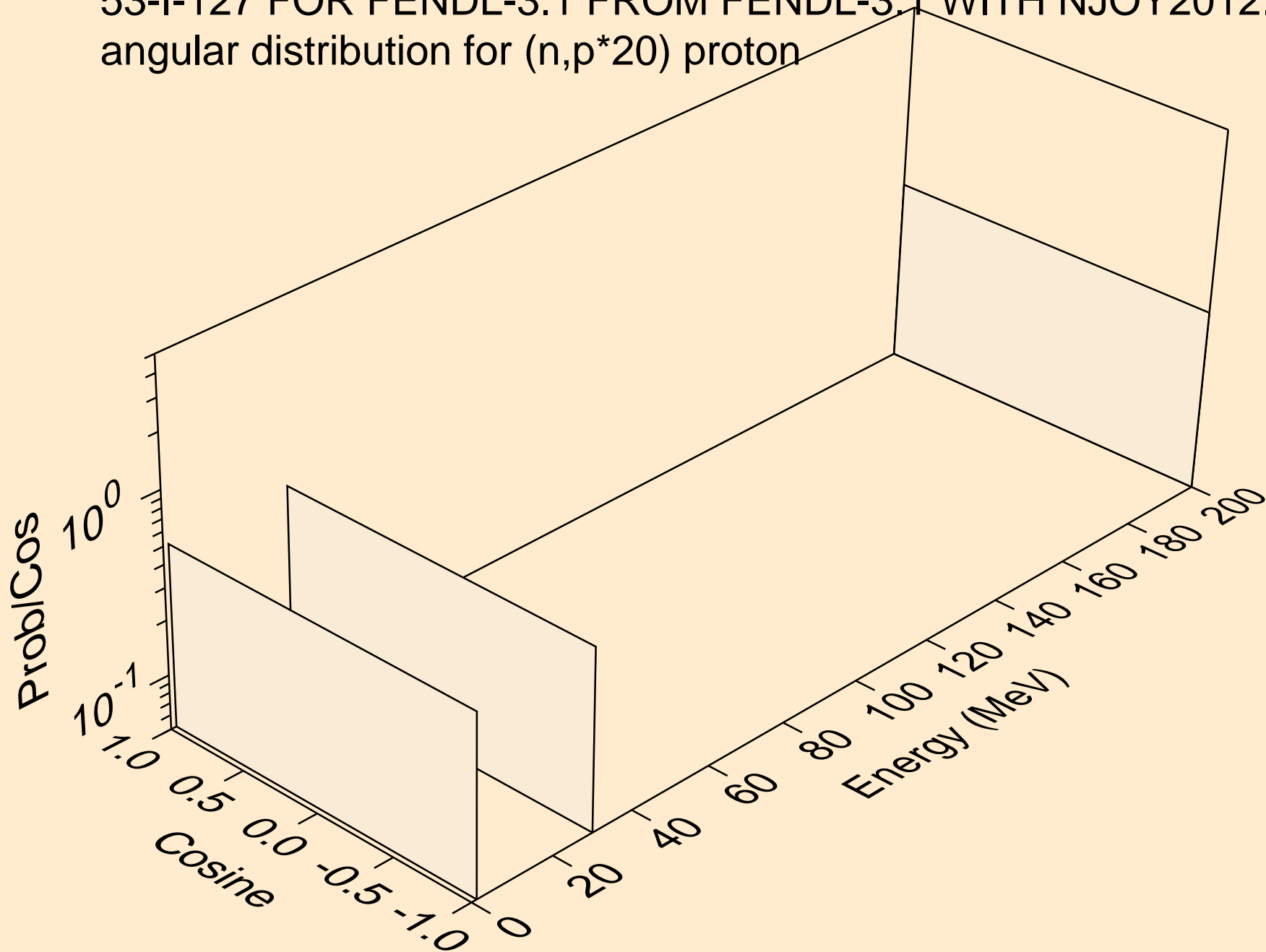

53-I-127 FOR FENDL-3.1 FROM FENDL-3.1 WITH NJOY2012.50+ C  
angular distribution for (n,p\*21) proton

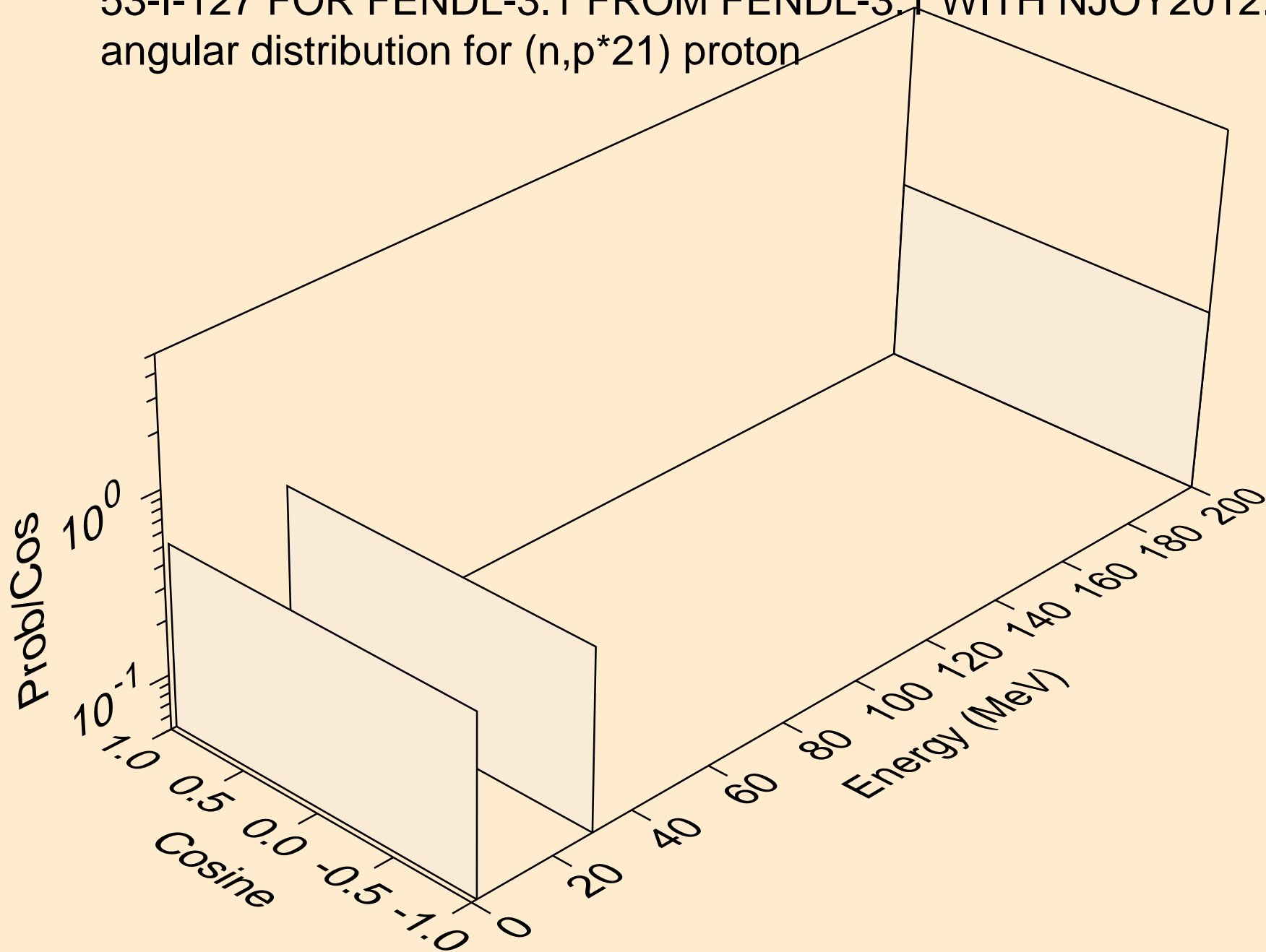

53-I-127 FOR FENDL-3.1 FROM FENDL-3.1 WITH NJOY2012.50+ C  
angular distribution for (n,p\*22) proton

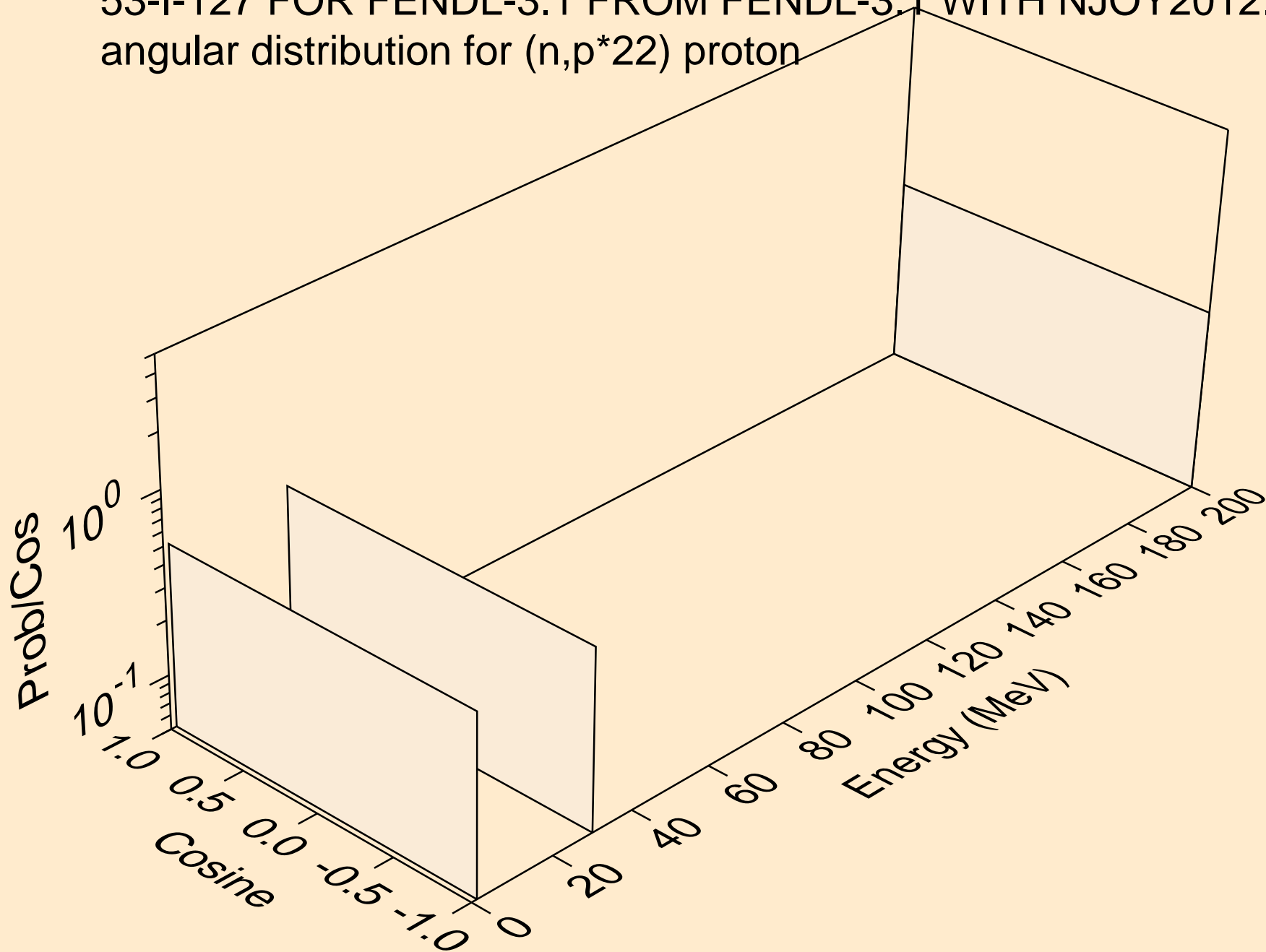

53-I-127 FOR FENDL-3.1 FROM FENDL-3.1 WITH NJOY2012.50+ C  
protons from (n,p\*c)

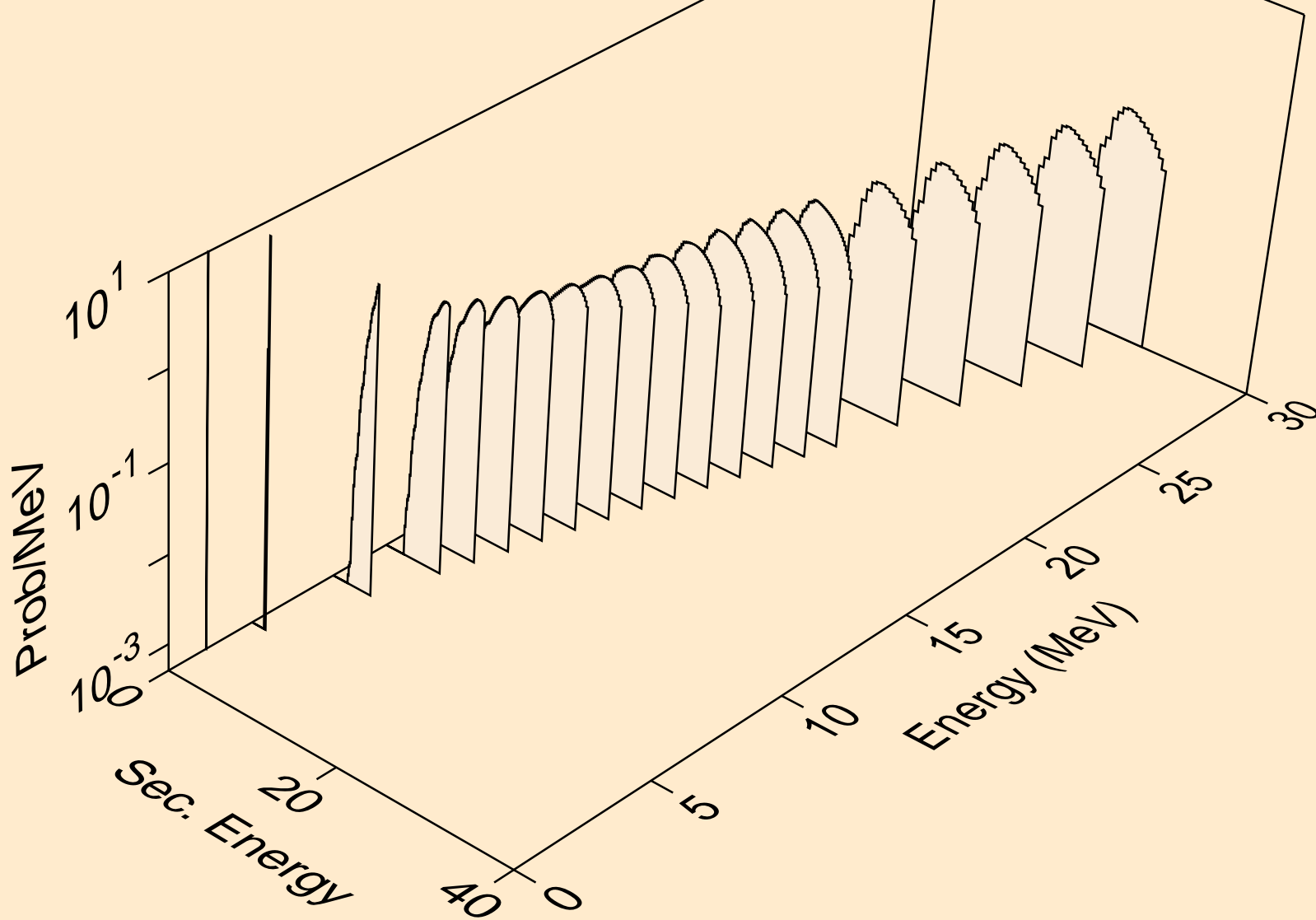

53-I-127 FOR FENDL-3.1 FROM FENDL-3.1 WITH NJOY2012.50+ C  
deuterons from (n,x)

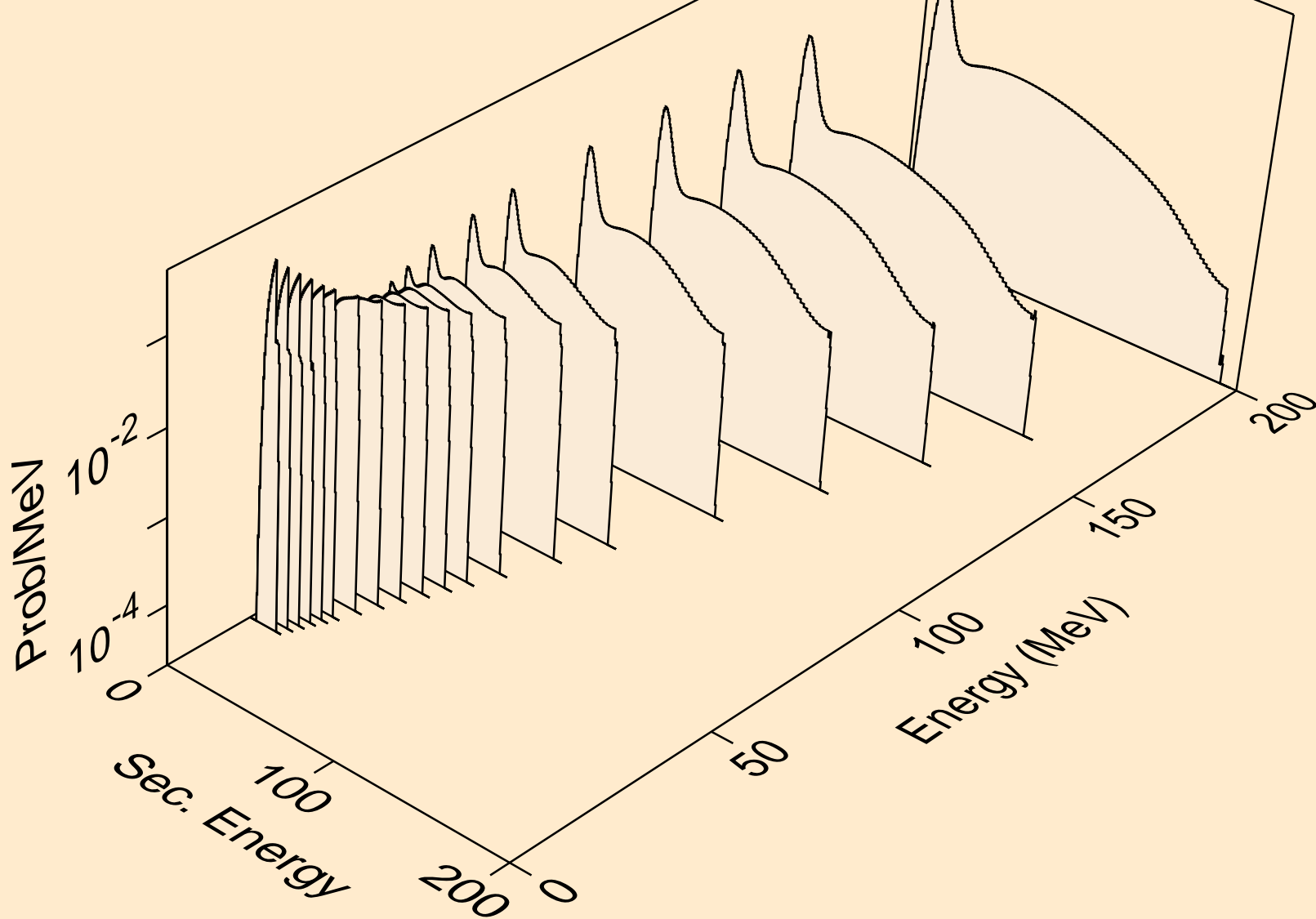



53-I-127 FOR FENDL-3.1 FROM FENDL-3.1 WITH NJOY2012.50+ C  
tritons from (n,x)

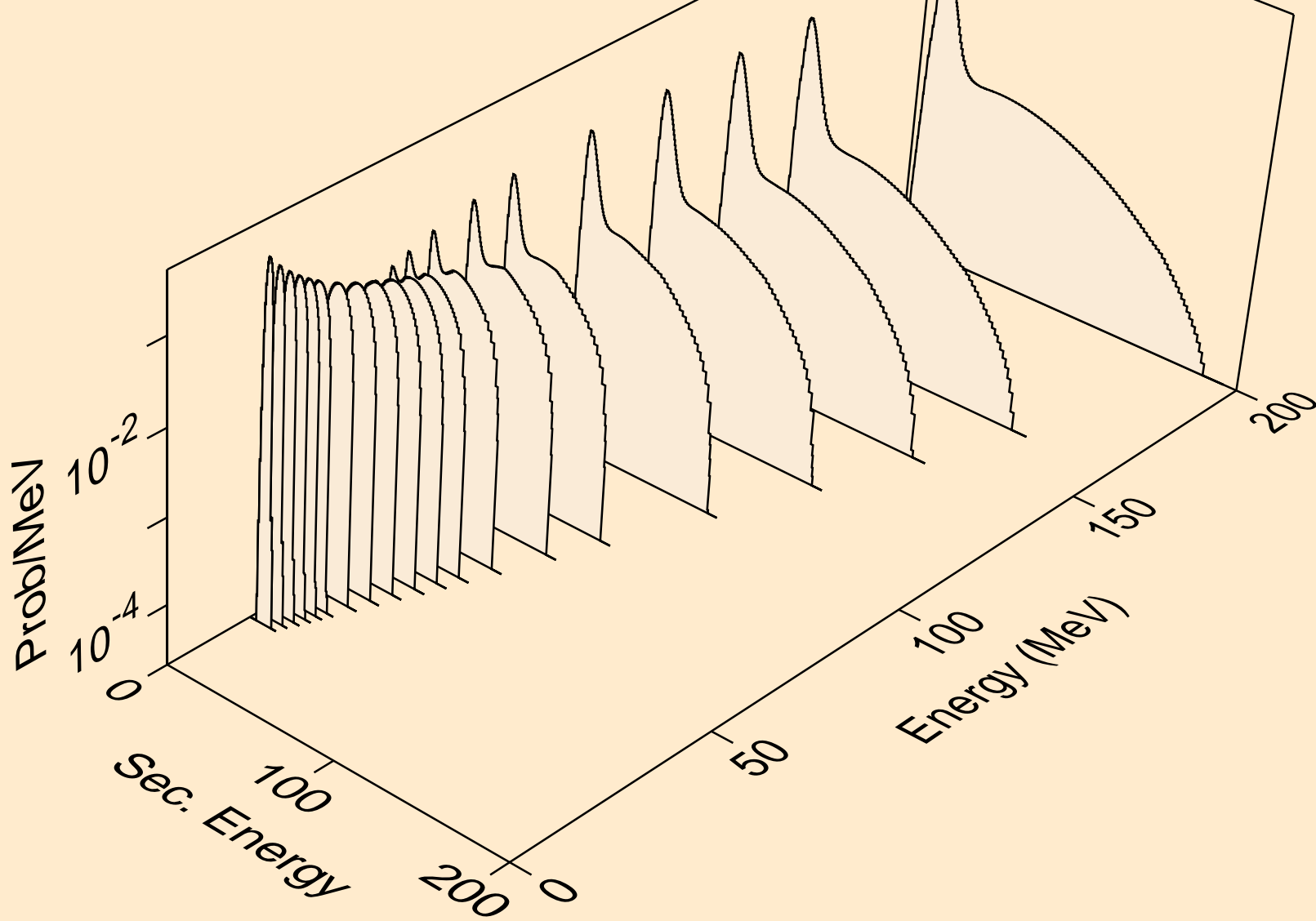

53-I-127 FOR FENDL-3.1 FROM FENDL-3.1 WITH NJOY2012.50+ C  
he3s from (n,x)

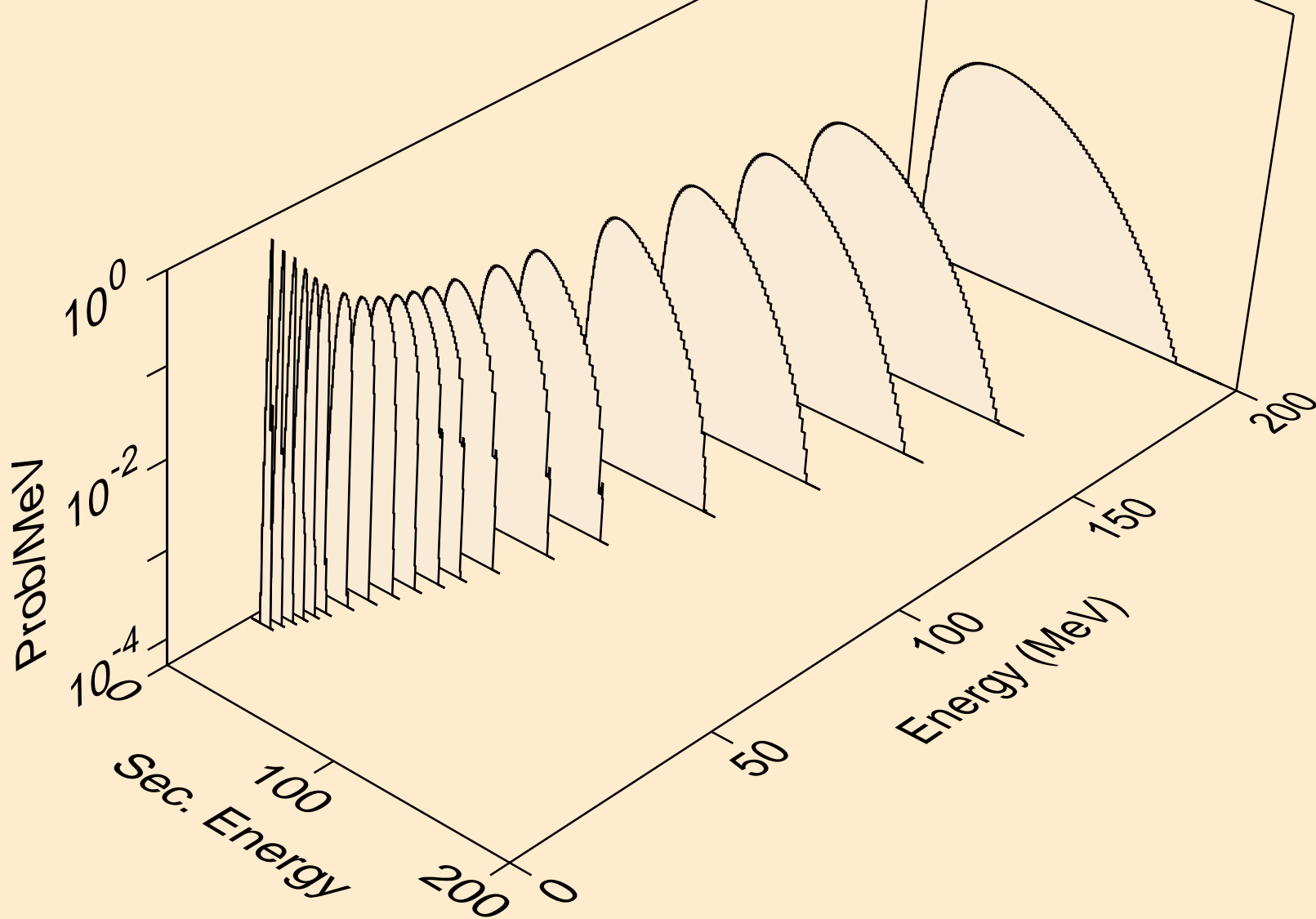

53-I-127 FOR FENDL-3.1 FROM FENDL-3.1 WITH NJOY2012.50+ (C)  
alphas from (n,x)

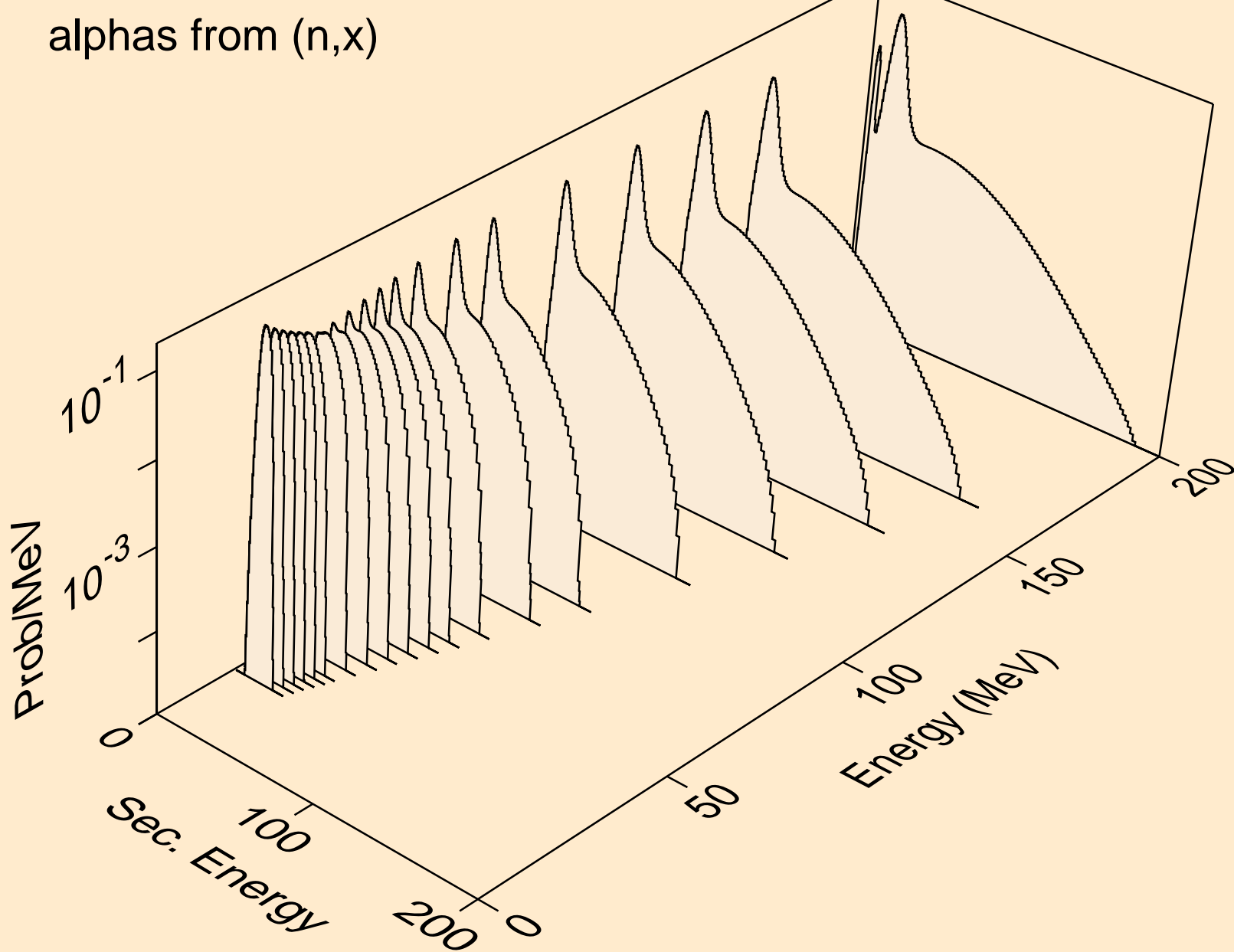

53-I-127 FOR FENDL-3.1 FROM FENDL-3.1 WITH NJOY2012.50+ C  
alphas from (n,n\*)a

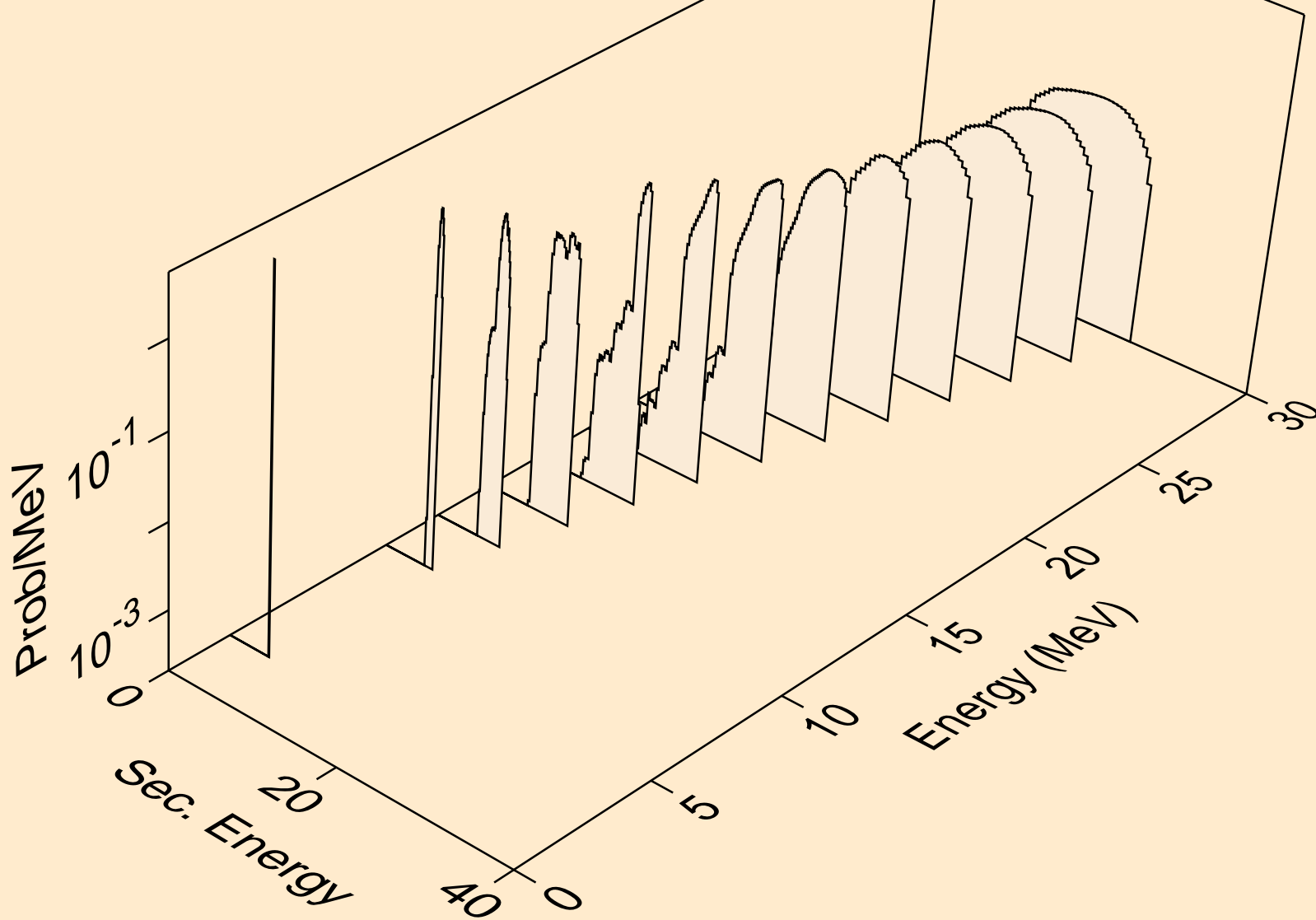

53-I-127 FOR FENDL-3.1 FROM FENDL-3.1 WITH NJOY2012.50+ C  
angular distribution for (n,a\*0) alpha

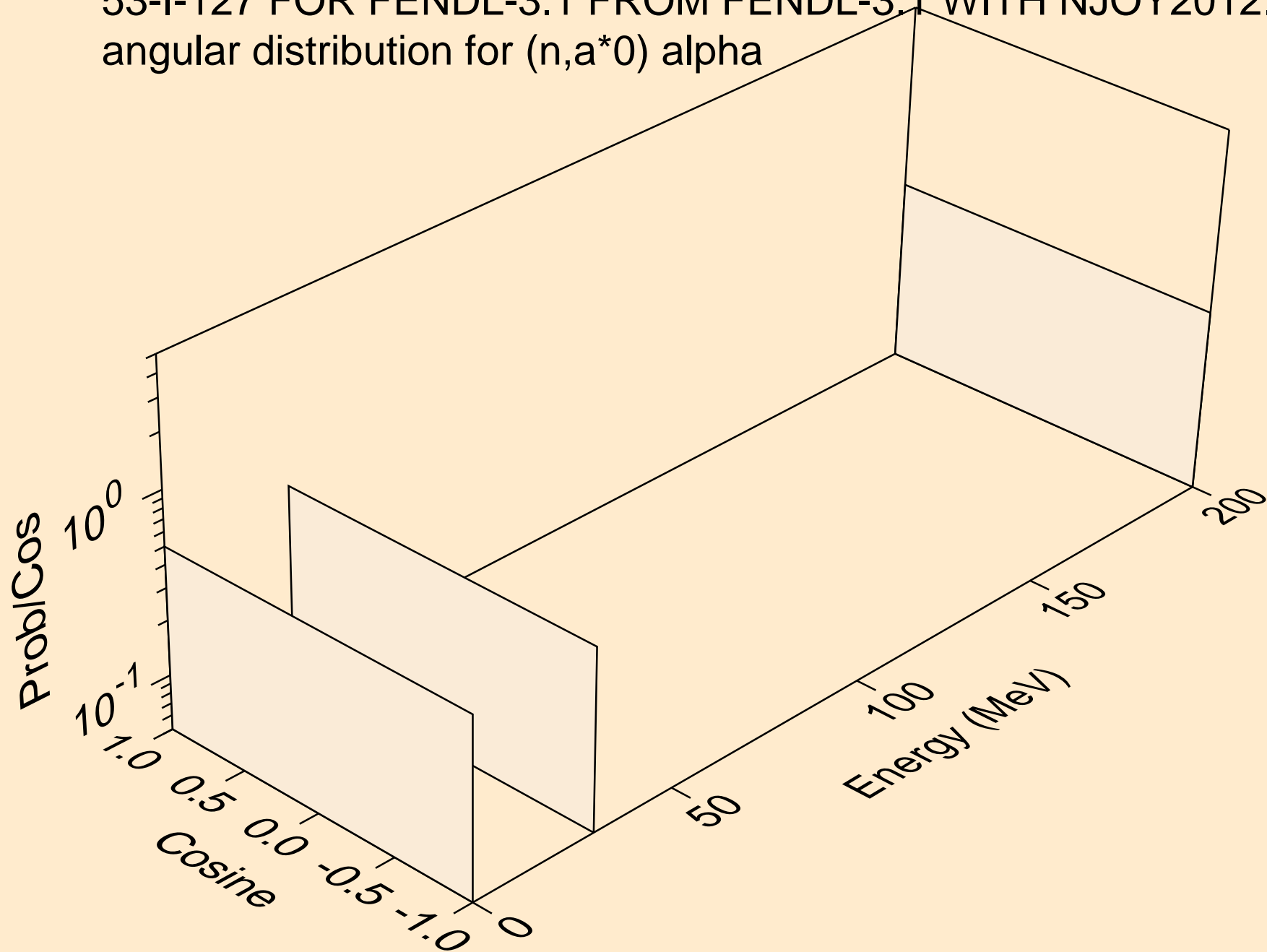

53-I-127 FOR FENDL-3.1 FROM FENDL-3.1 WITH NJOY2012.50+ C  
angular distribution for (n,a\*1) alpha

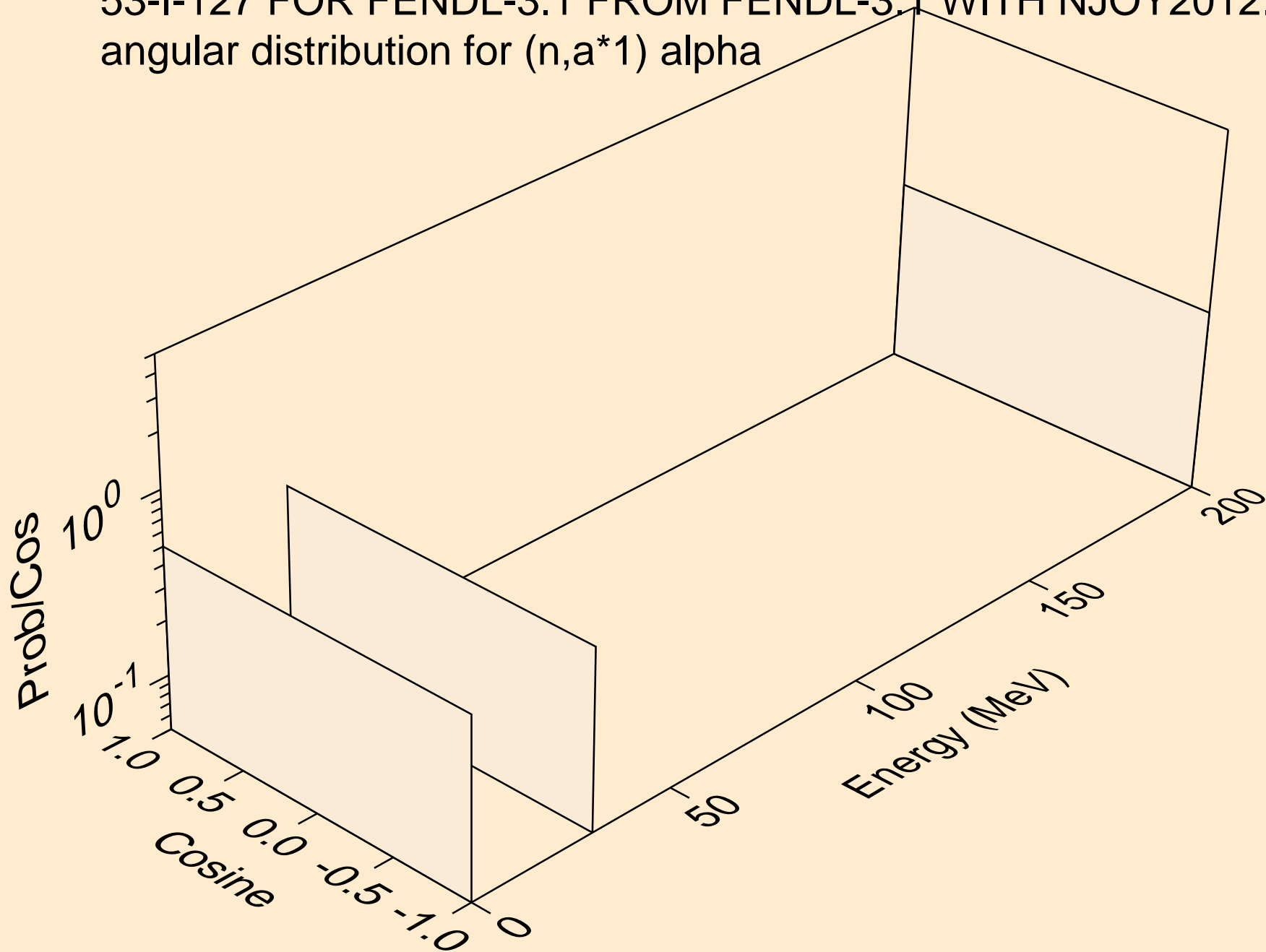

53-I-127 FOR FENDL-3.1 FROM FENDL-3.1 WITH NJOY2012.50+ C  
alphas from (n,a\*c)

