

64-GD-160 FOR FENDL-3.1 FROM FENDL-3.1 WITH NJOY2012.50  
Principal cross sections

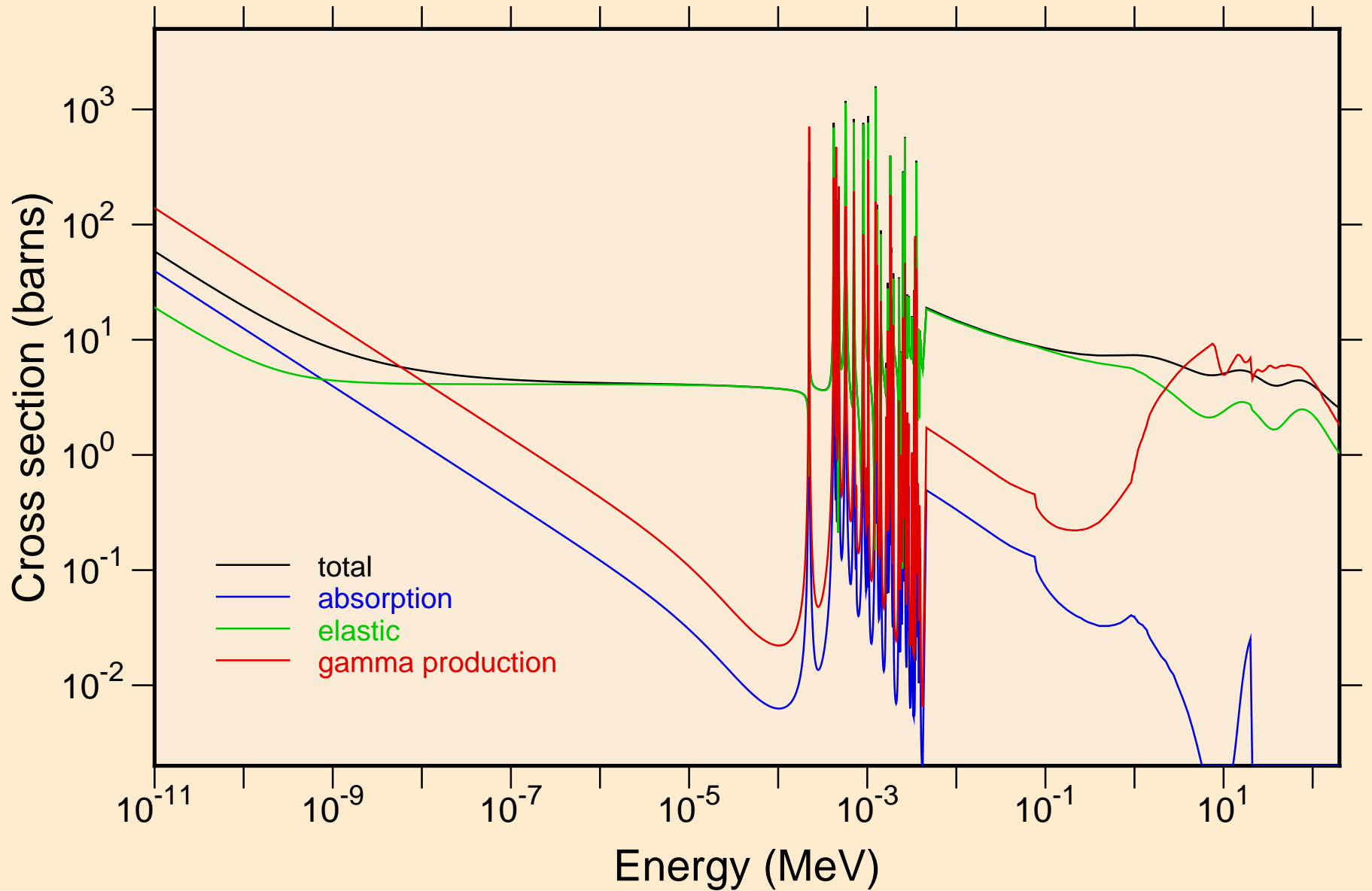

64-GD-160 FOR FENDL-3.1 FROM FENDL-3.1 WITH NJOY2012.50  
resonance total cross section

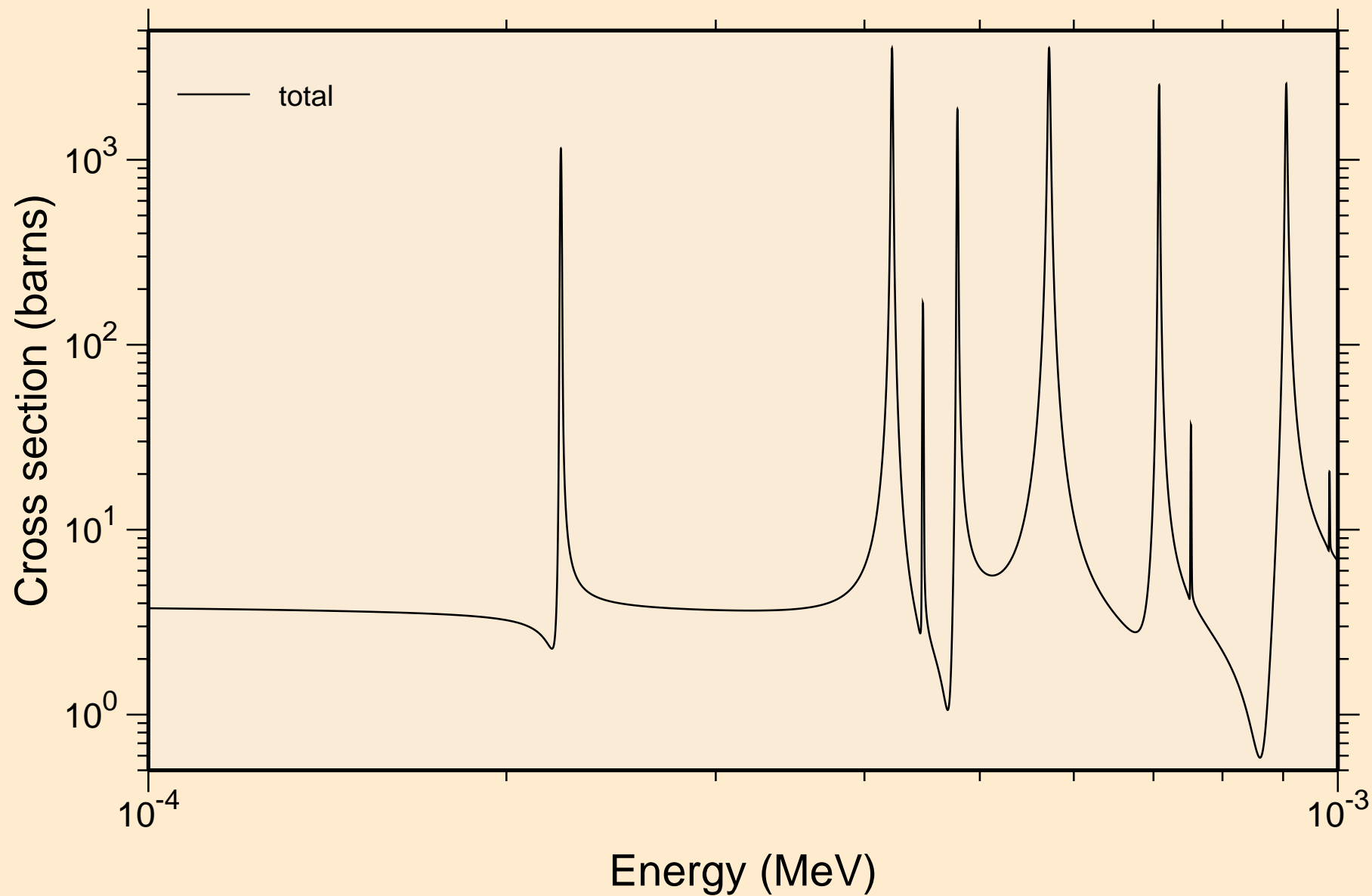

64-GD-160 FOR FENDL-3.1 FROM FENDL-3.1 WITH NJOY2012.50  
resonance total cross section

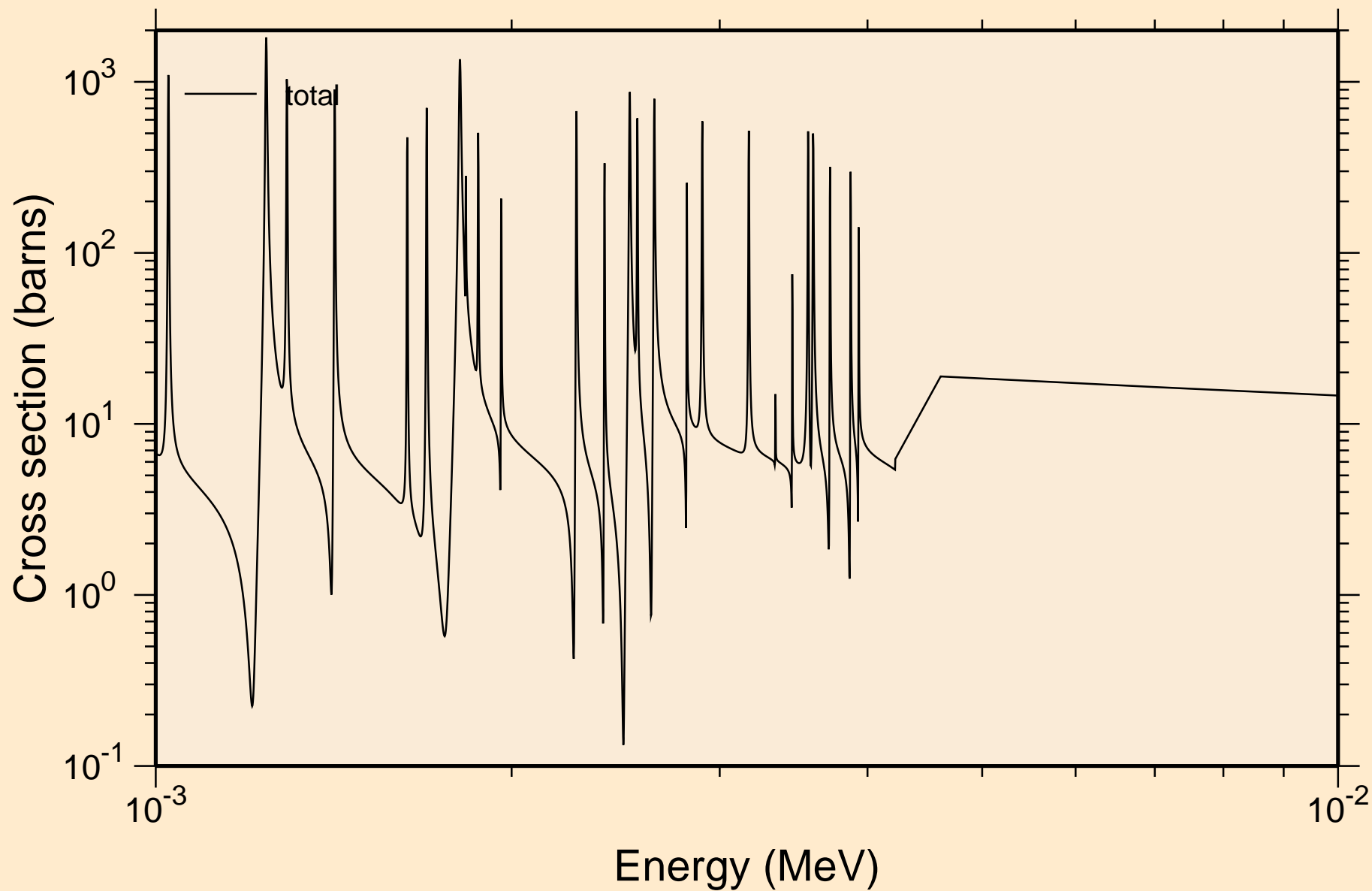

64-GD-160 FOR FENDL-3.1 FROM FENDL-3.1 WITH NJOY2012.50  
resonance total cross section

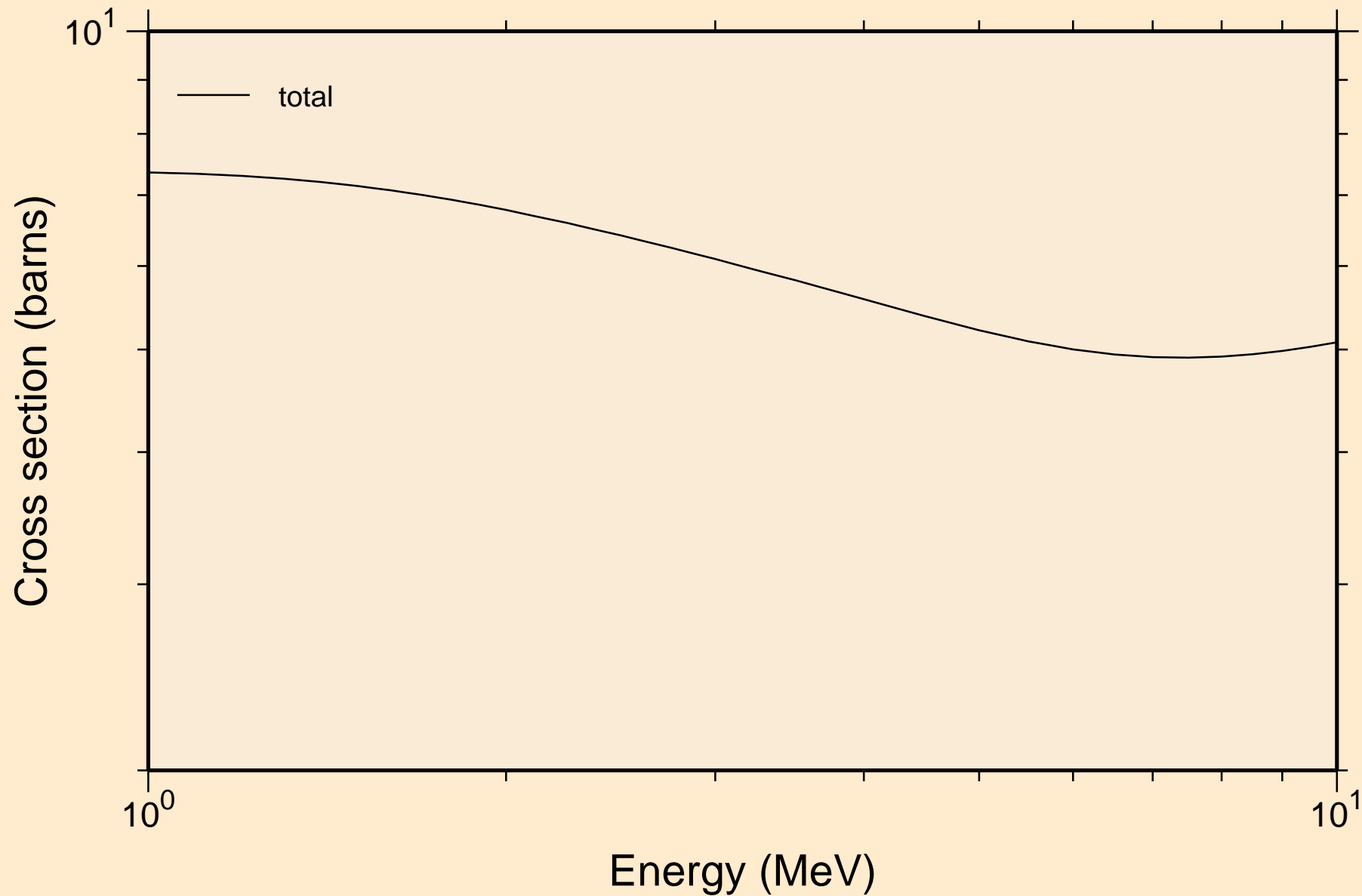

64-GD-160 FOR FENDL-3.1 FROM FENDL-3.1 WITH NJOY2012.50  
resonance absorption cross sections

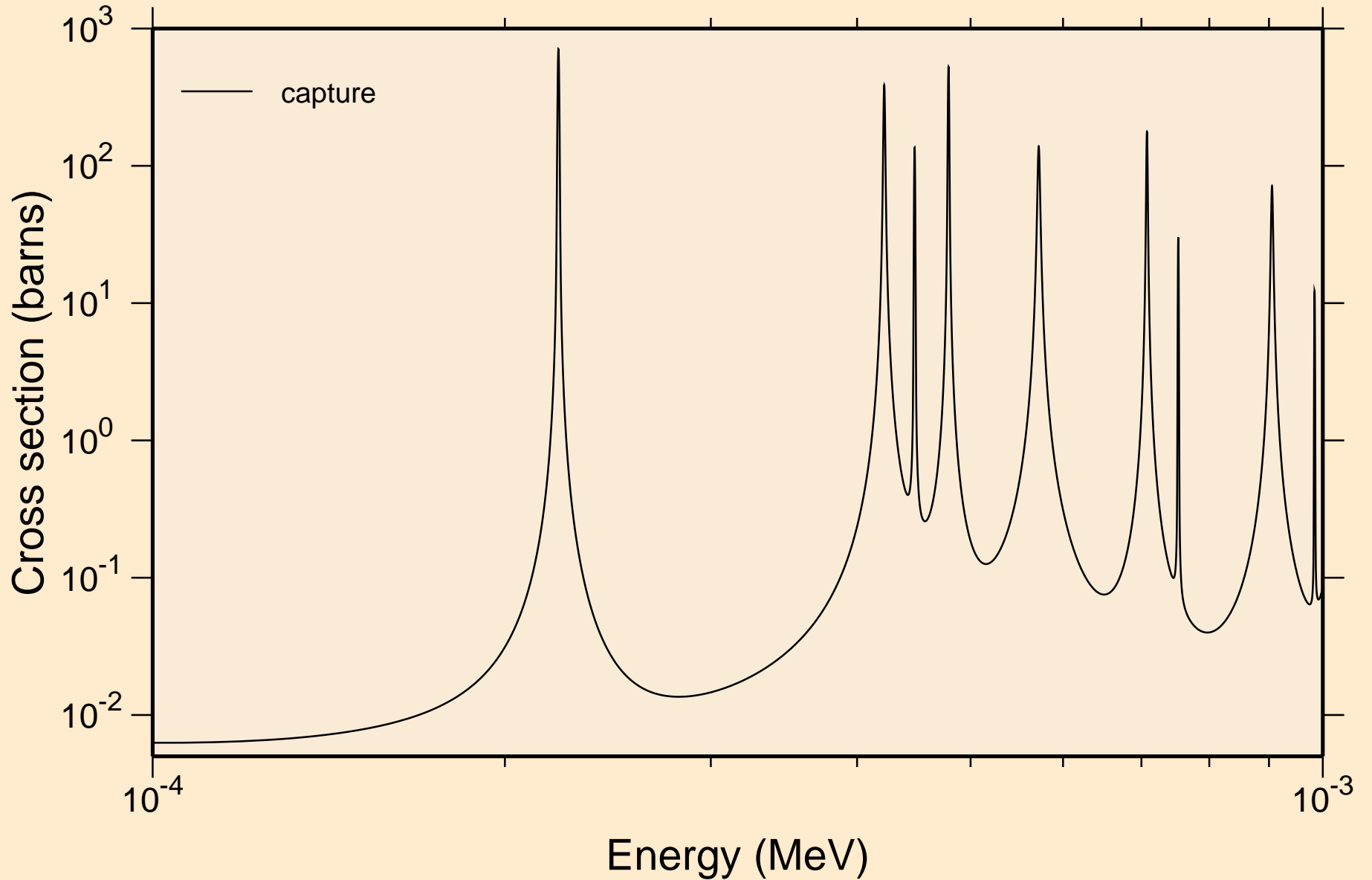

64-GD-160 FOR FENDL-3.1 FROM FENDL-3.1 WITH NJOY2012.50  
resonance absorption cross sections

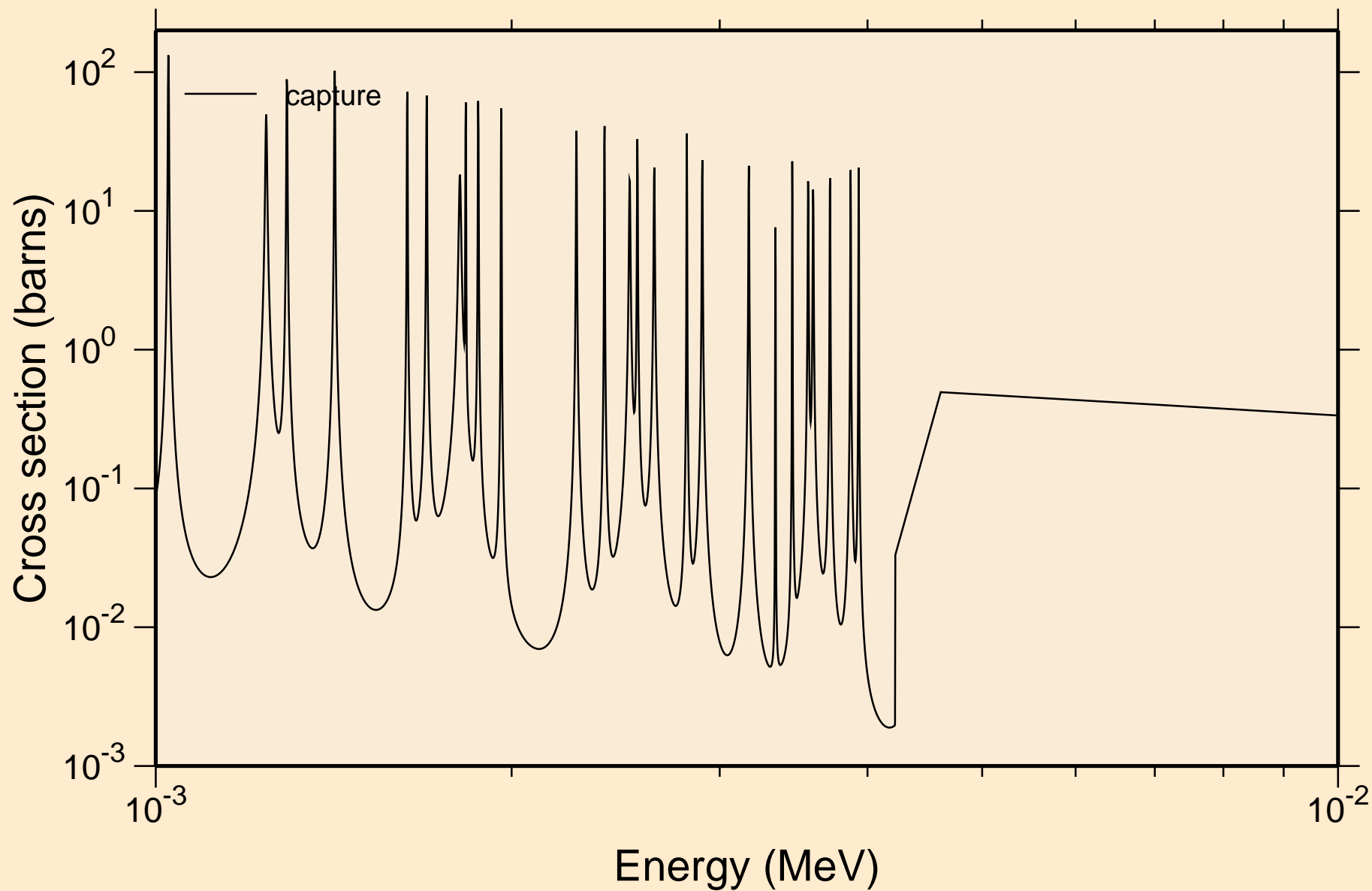

64-GD-160 FOR FENDL-3.1 FROM FENDL-3.1 WITH NJOY2012.50  
resonance absorption cross sections

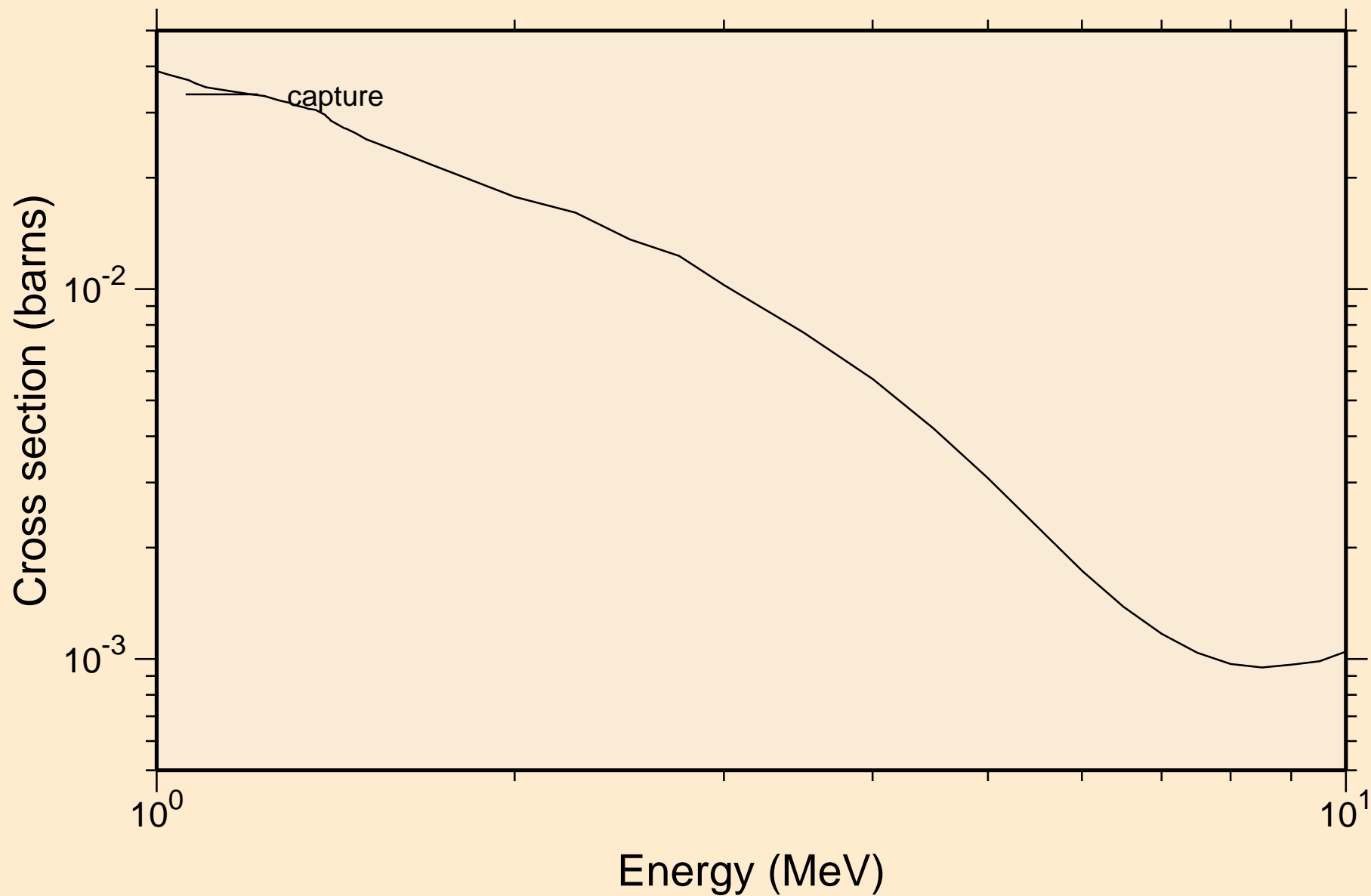

64-GD-160 FOR FENDL-3.1 FROM FENDL-3.1 WITH NJOY2012.50  
UR total cross section

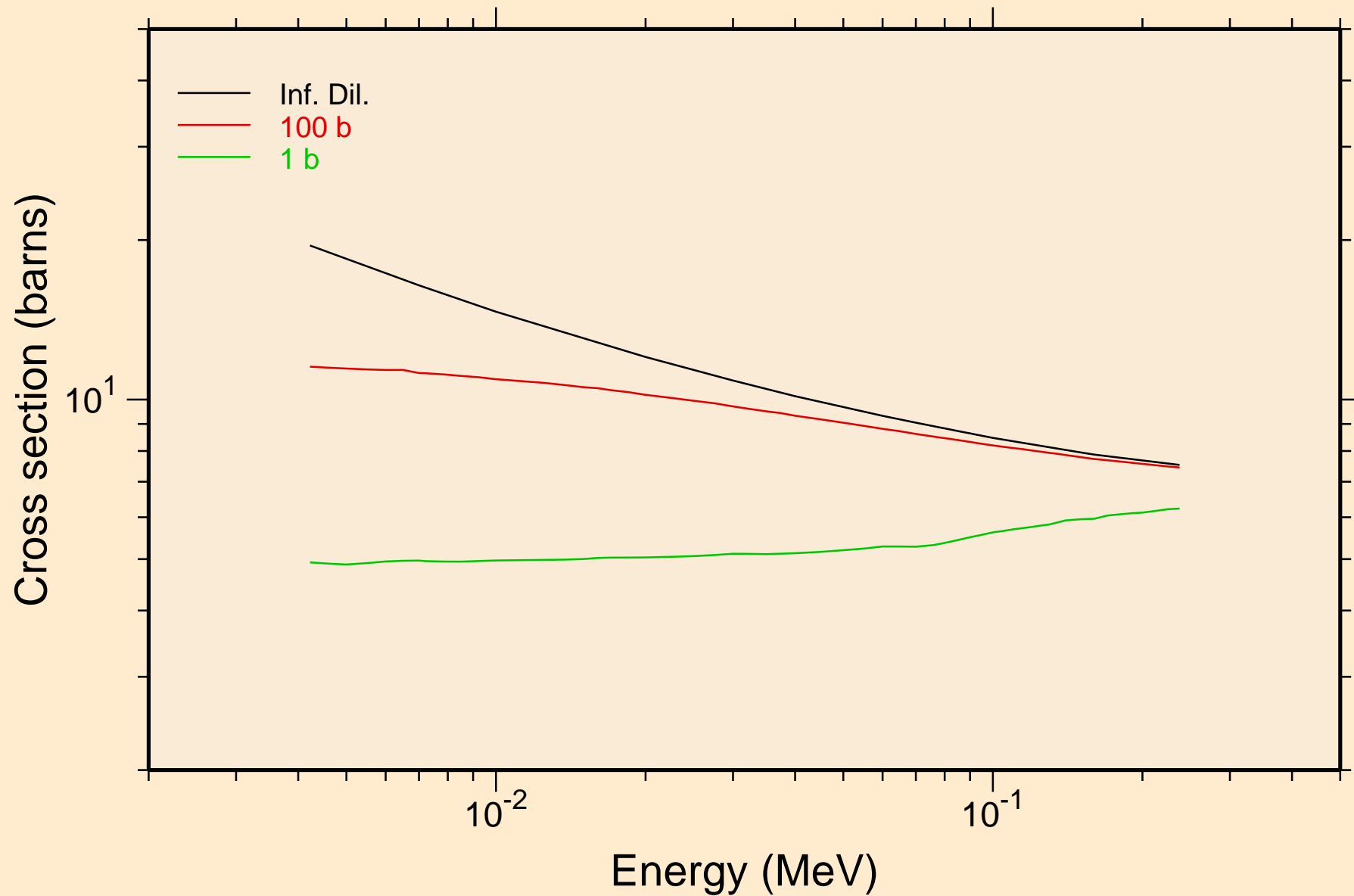



64-GD-160 FOR FENDL-3.1 FROM FENDL-3.1 WITH NJOY2012.50  
UR elastic cross section

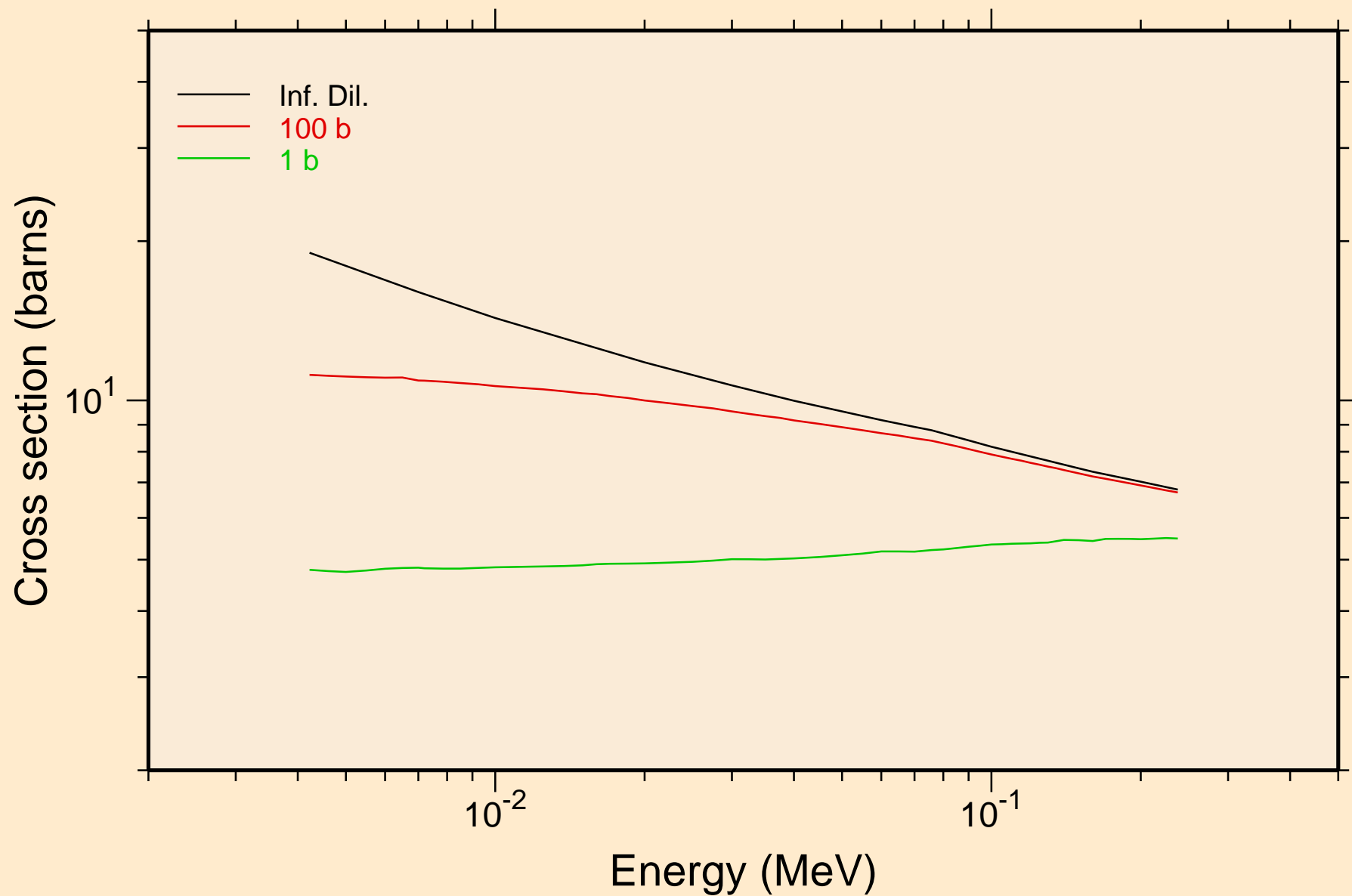

64-GD-160 FOR FENDL-3.1 FROM FENDL-3.1 WITH NJOY2012.50  
UR capture cross section

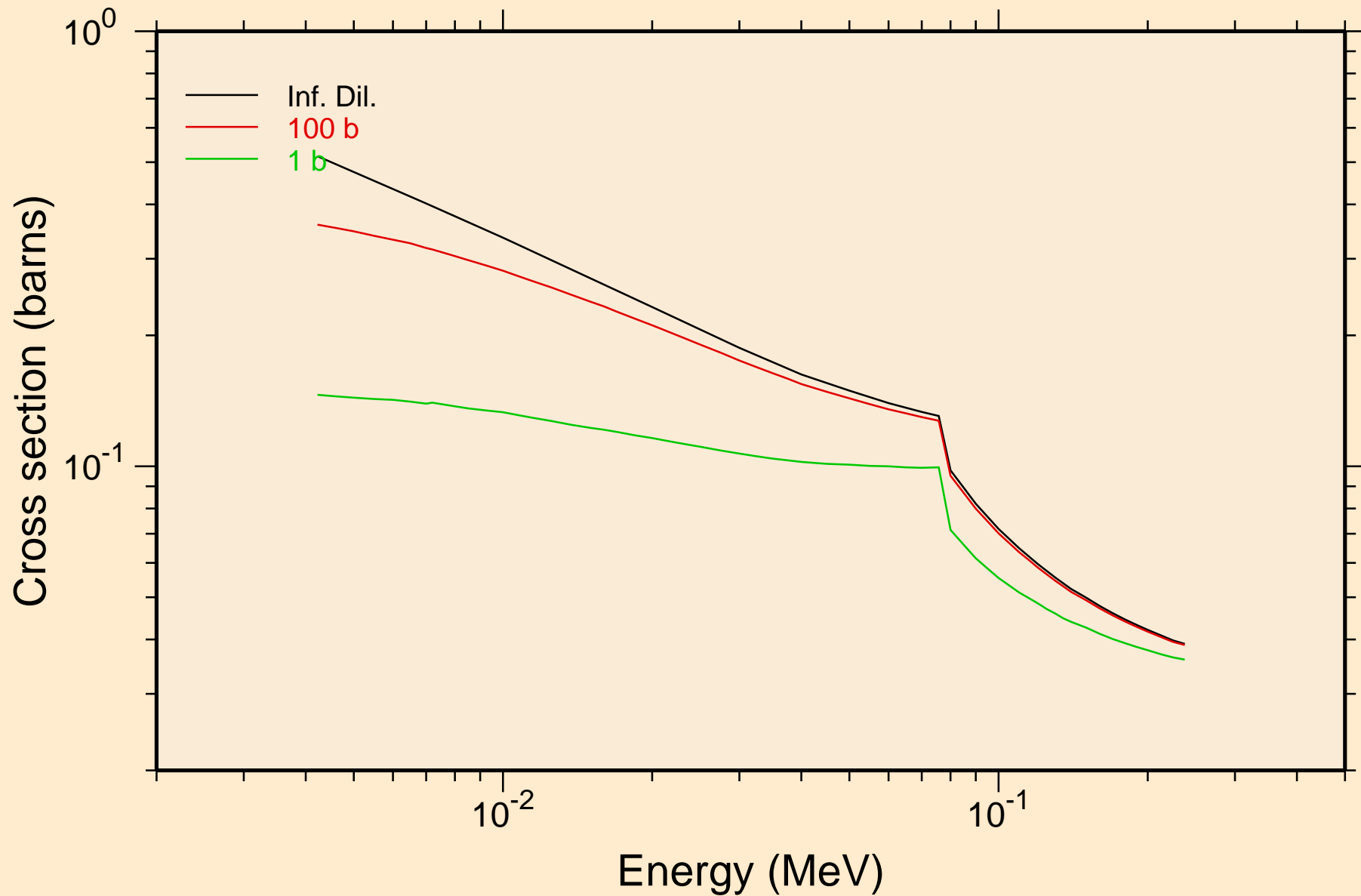

# 64-GD-160 FOR FENDL-3.1 FROM FENDL-3.1 WITH NJOY2012.50 Heating

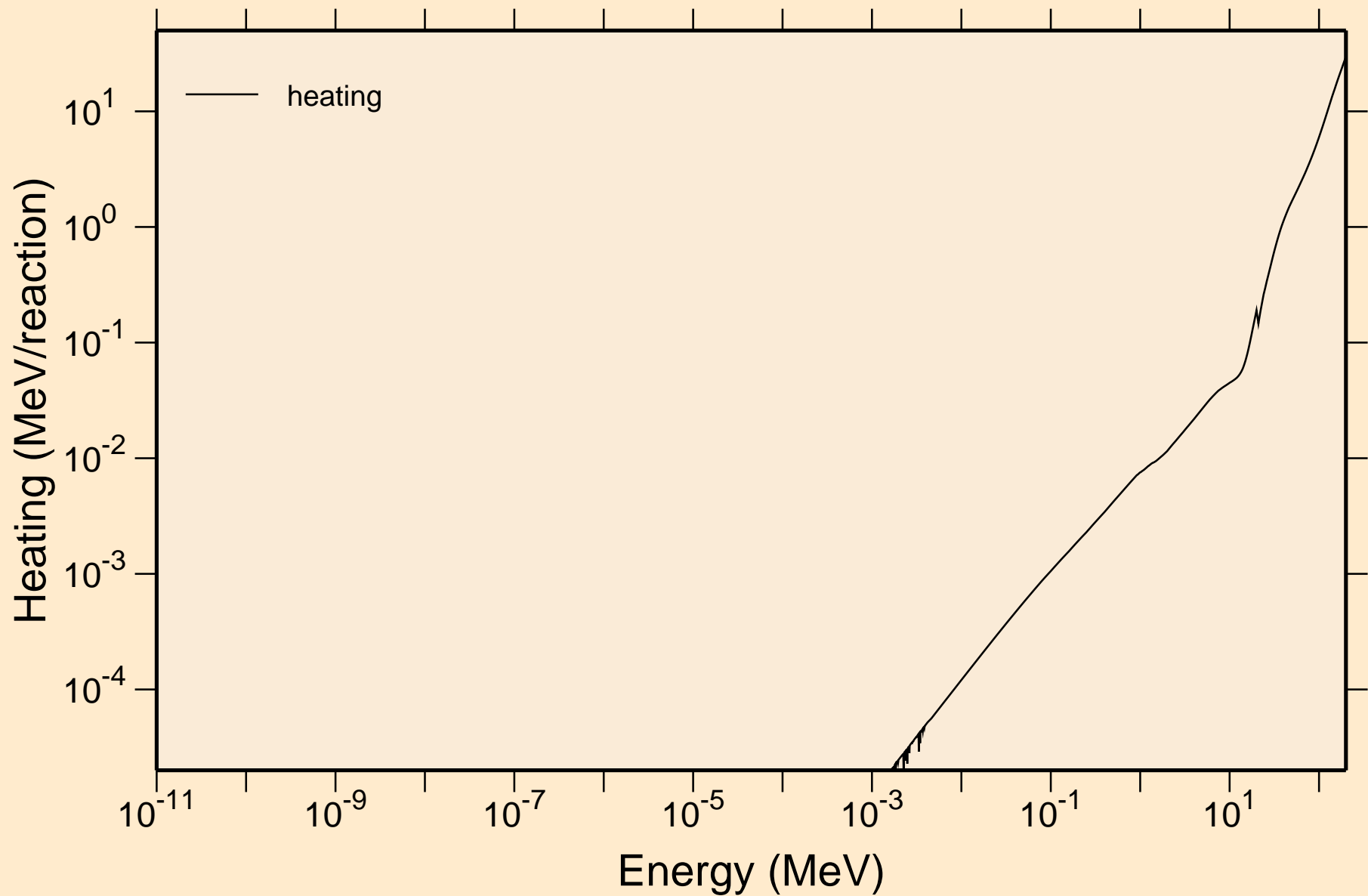

# 64-GD-160 FOR FENDL-3.1 FROM FENDL-3.1 WITH NJOY2012.50 Damage

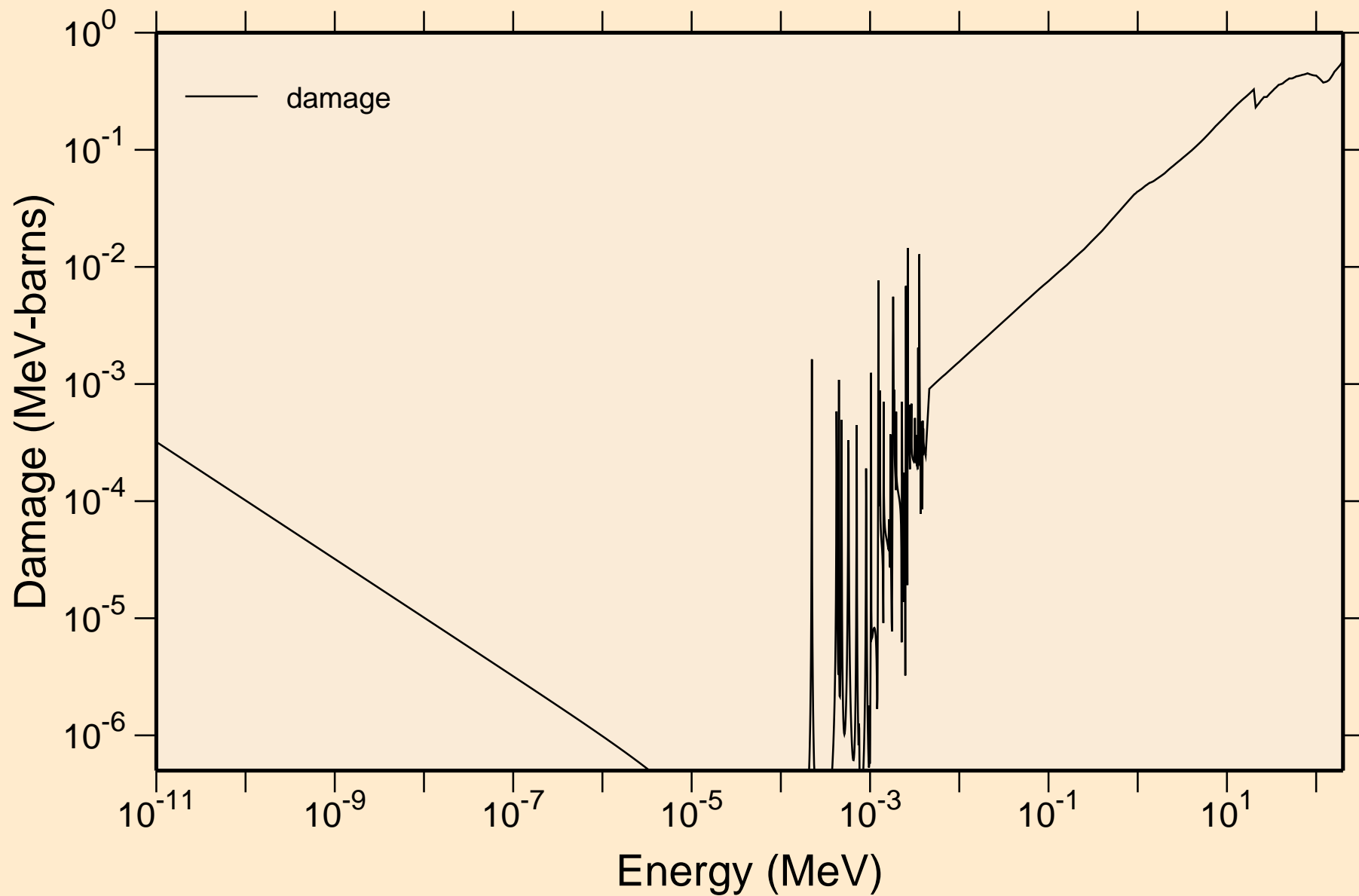

64-GD-160 FOR FENDL-3.1 FROM FENDL-3.1 WITH NJOY2012.50  
Non-threshold reactions

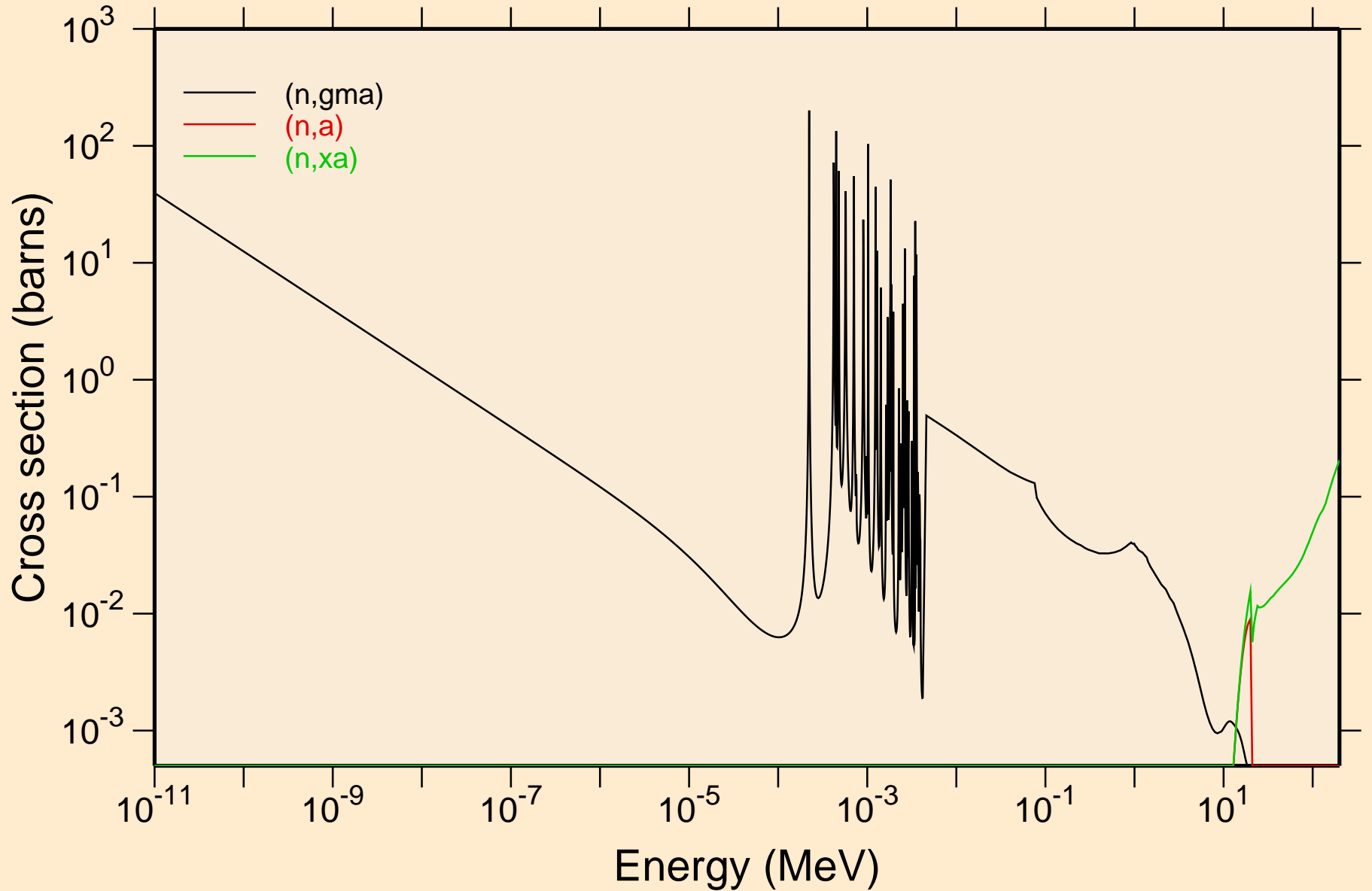

64-GD-160 FOR FENDL-3.1 FROM FENDL-3.1 WITH NJOY2012.50  
Principal cross sections

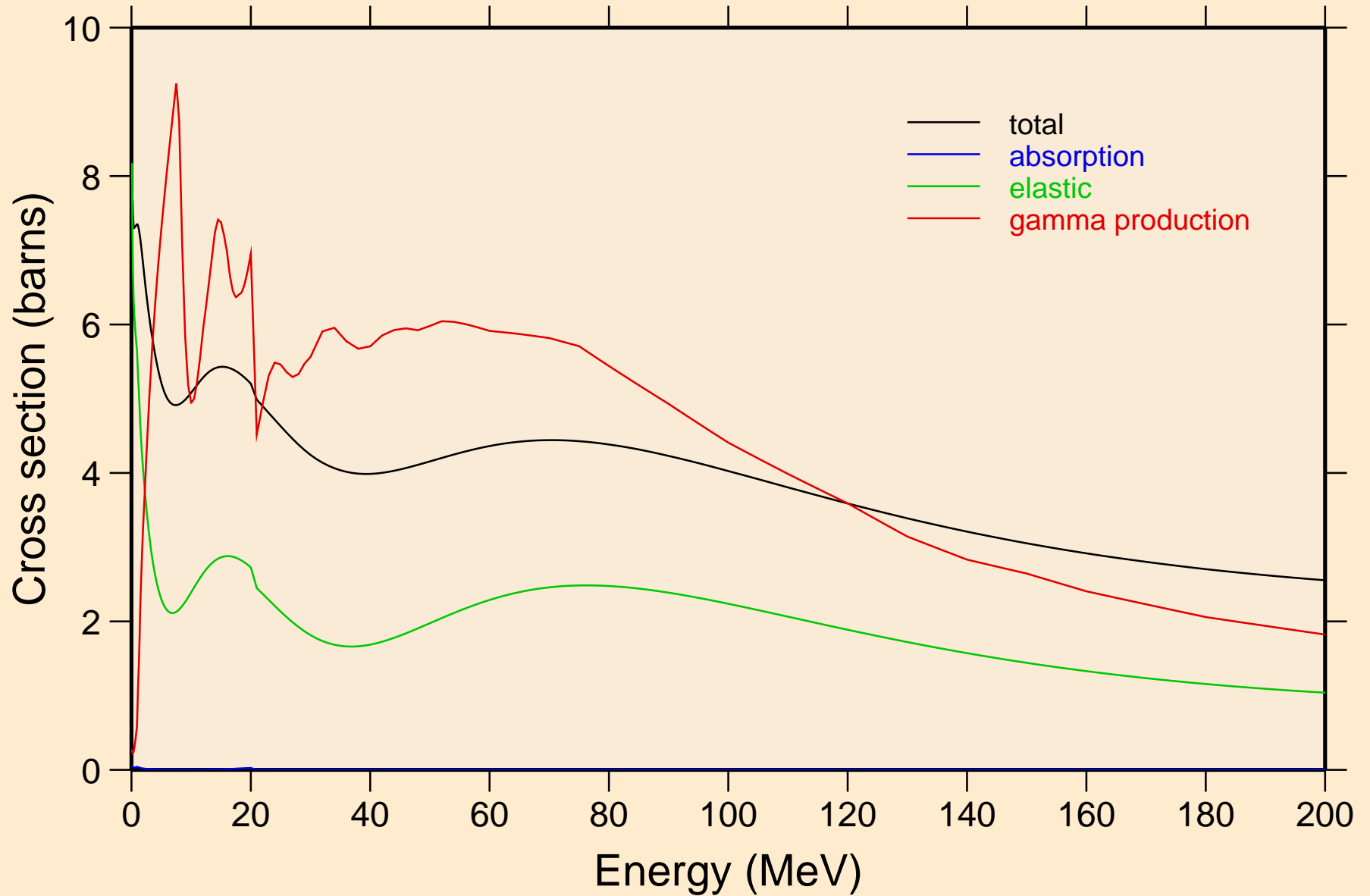

# 64-GD-160 FOR FENDL-3.1 FROM FENDL-3.1 WITH NJOY2012.50 Heating

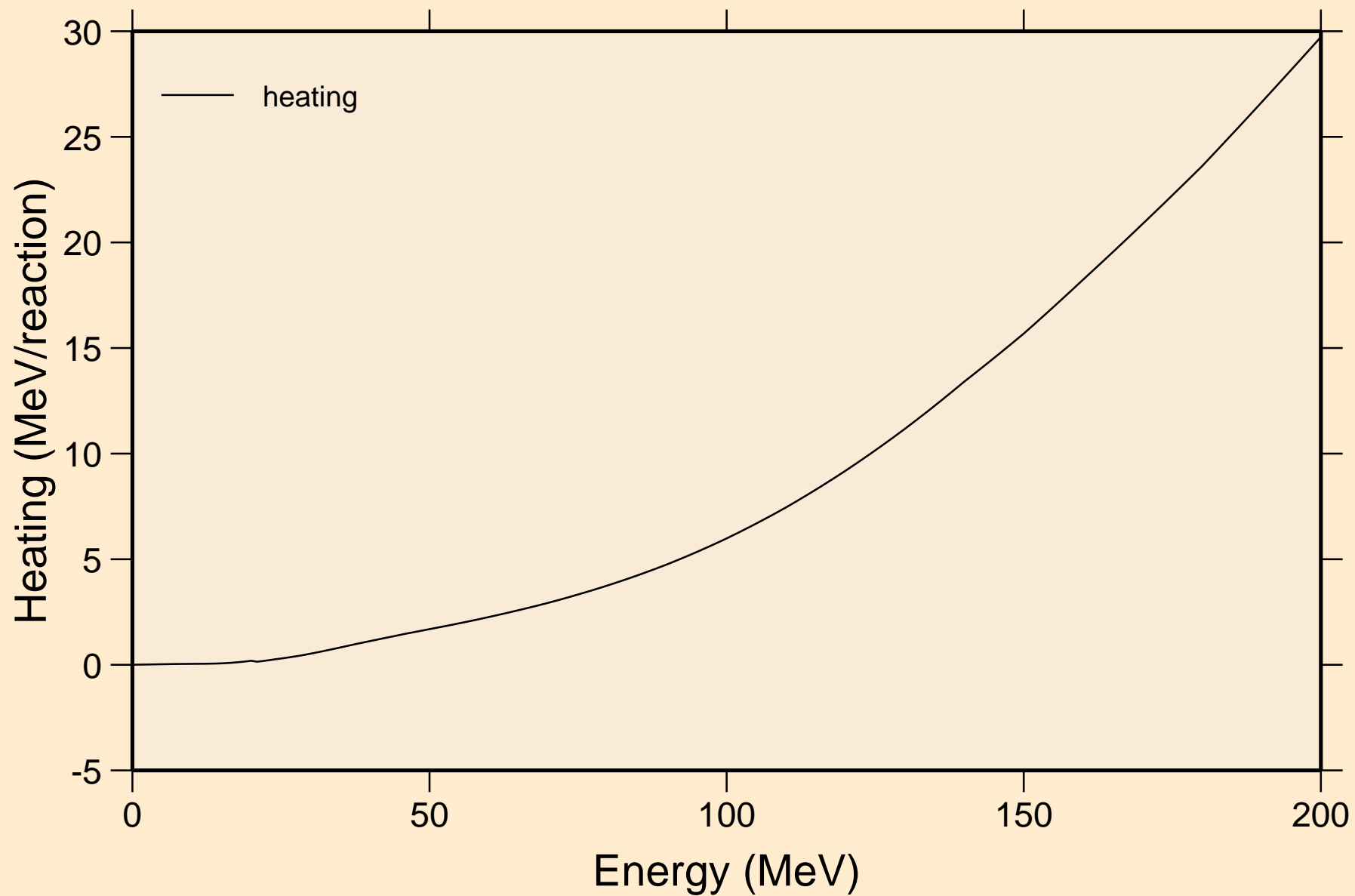

# 64-GD-160 FOR FENDL-3.1 FROM FENDL-3.1 WITH NJOY2012.50 Damage

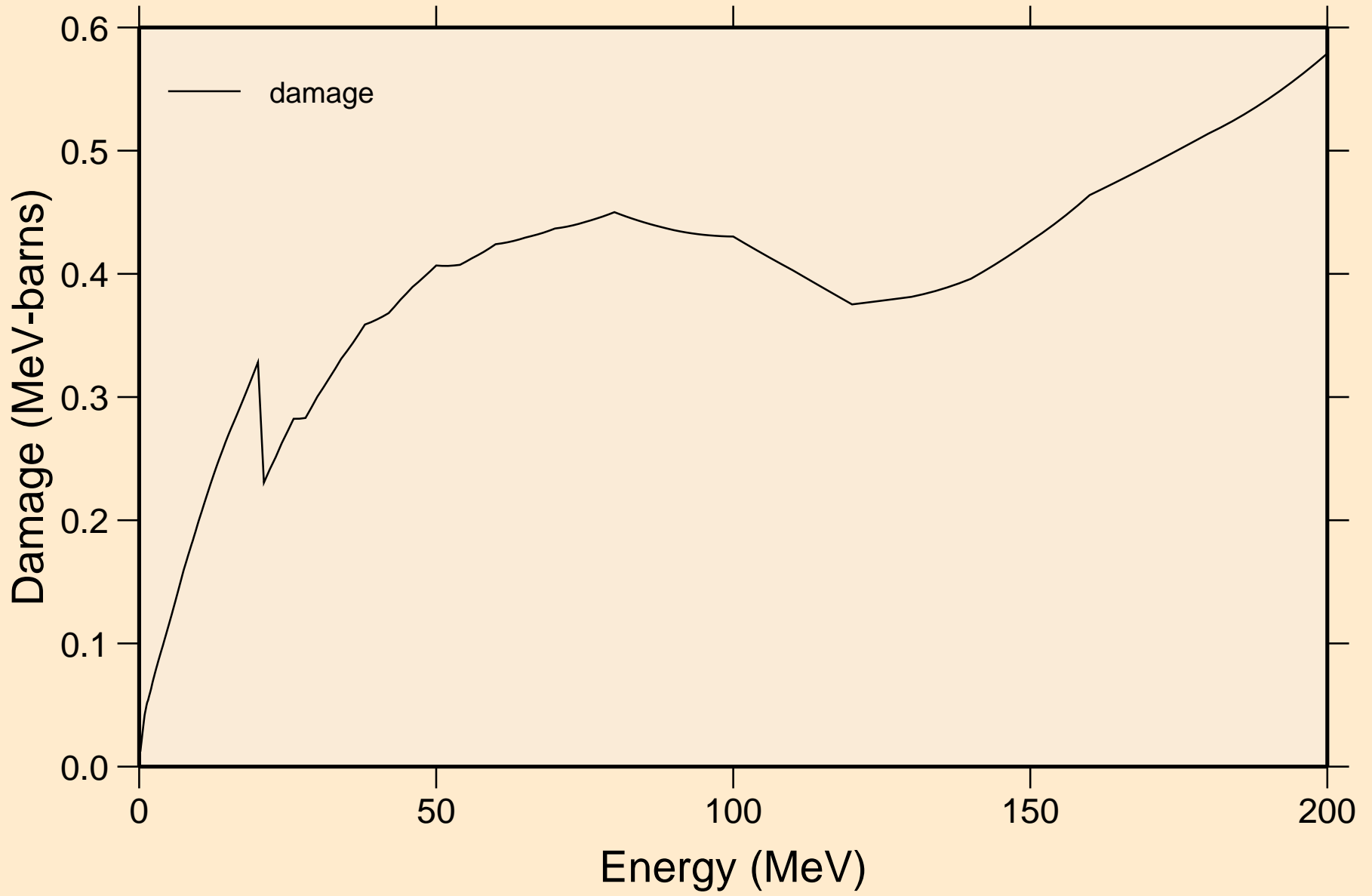



64-GD-160 FOR FENDL-3.1 FROM FENDL-3.1 WITH NJOY2012.50  
Non-threshold reactions

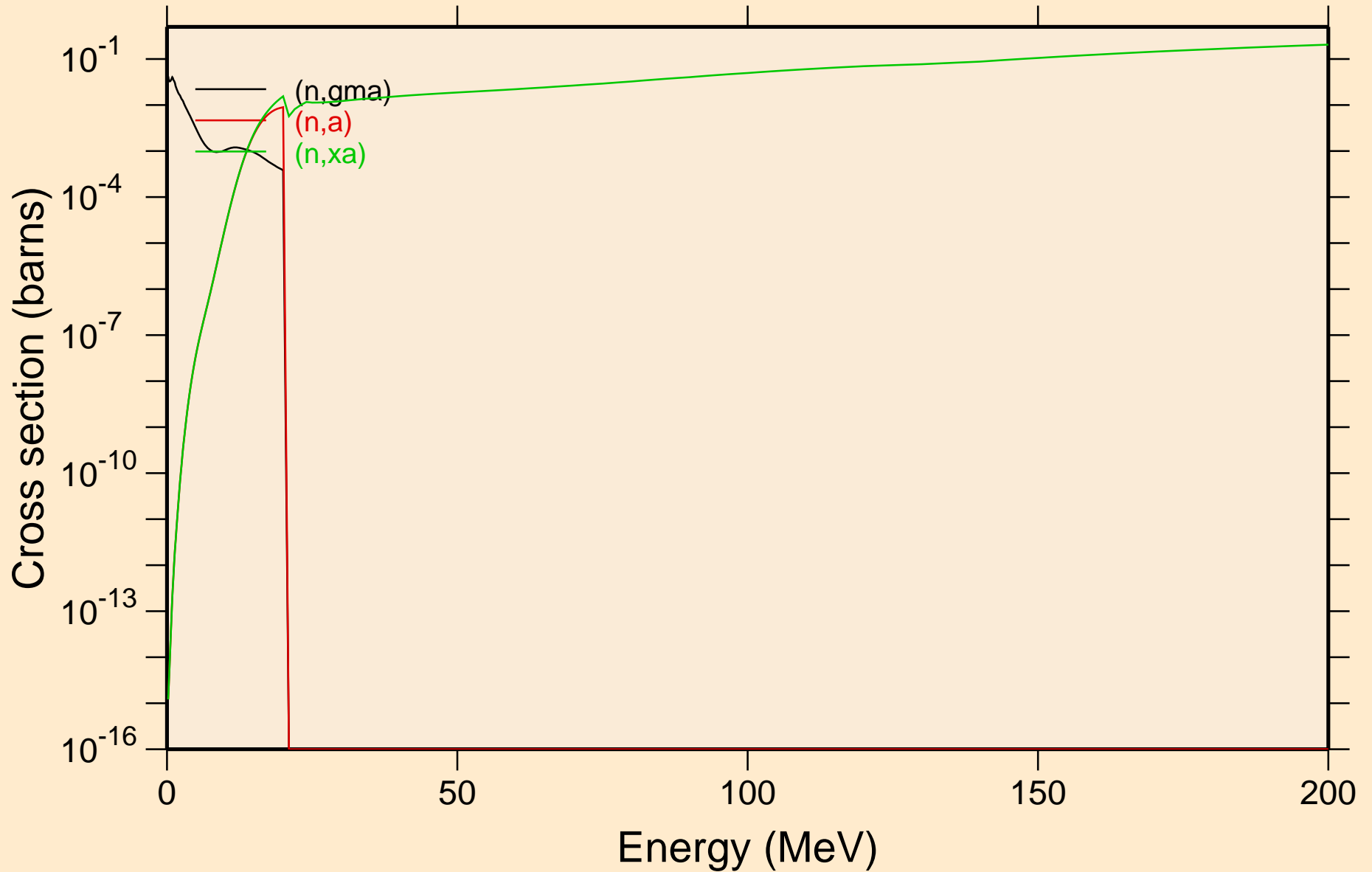

64-GD-160 FOR FENDL-3.1 FROM FENDL-3.1 WITH NJOY2012.50  
Inelastic levels

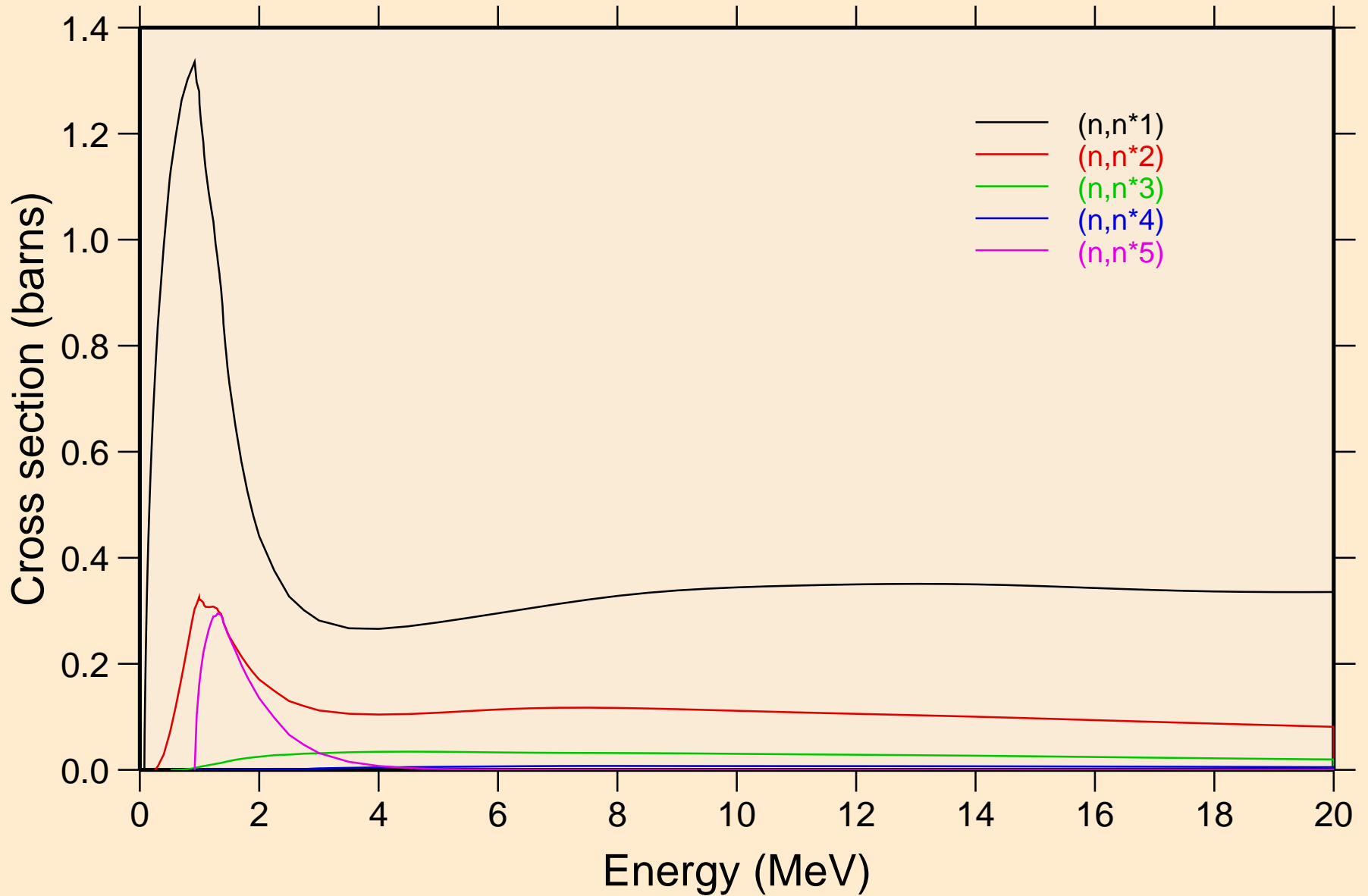

# 64-GD-160 FOR FENDL-3.1 FROM FENDL-3.1 WITH NJOY2012.50

## Inelastic levels

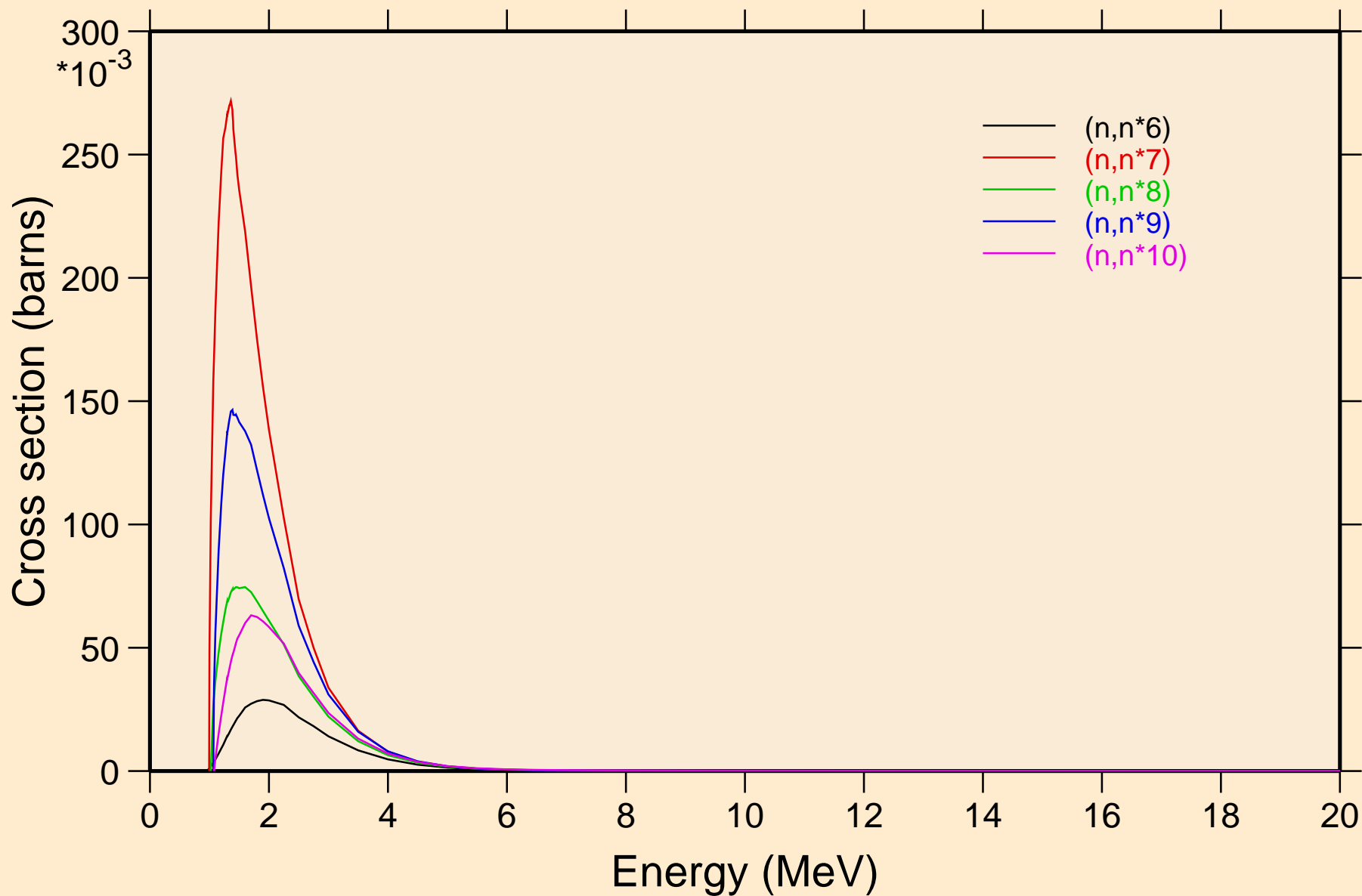

64-GD-160 FOR FENDL-3.1 FROM FENDL-3.1 WITH NJOY2012.50  
Inelastic levels

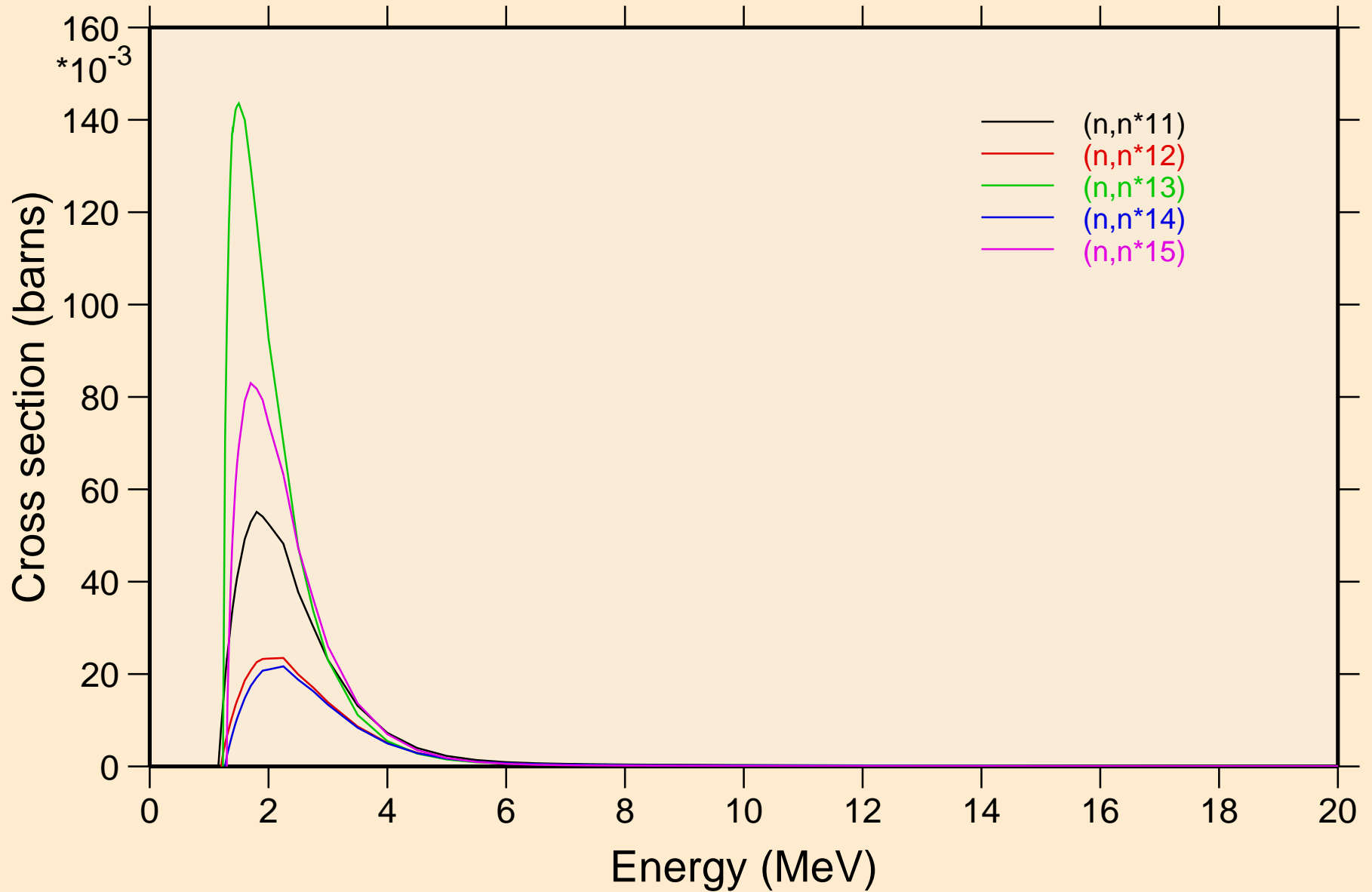

# 64-GD-160 FOR FENDL-3.1 FROM FENDL-3.1 WITH NJOY2012.50

## Inelastic levels

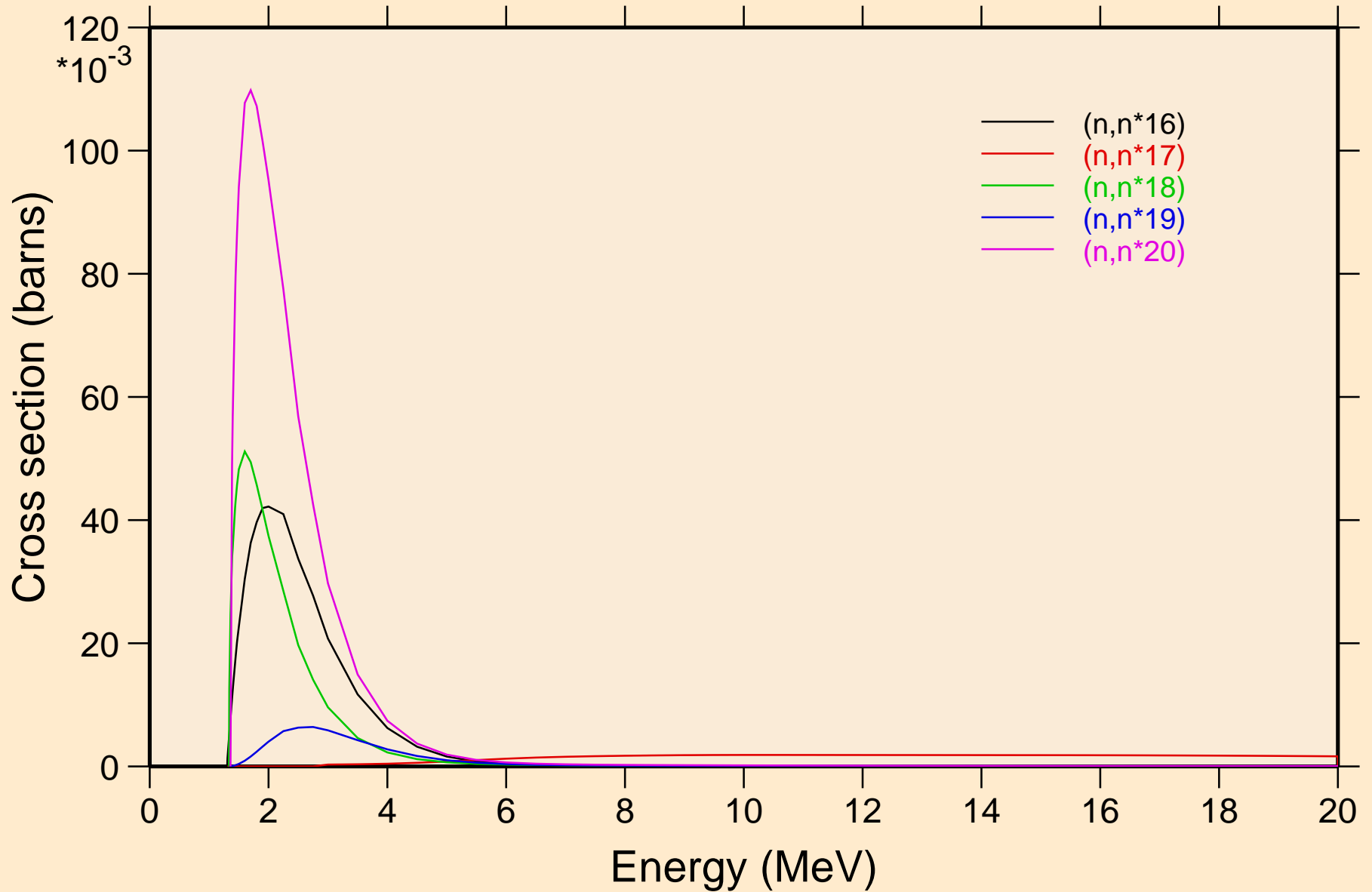

# 64-GD-160 FOR FENDL-3.1 FROM FENDL-3.1 WITH NJOY2012.50

## Inelastic levels

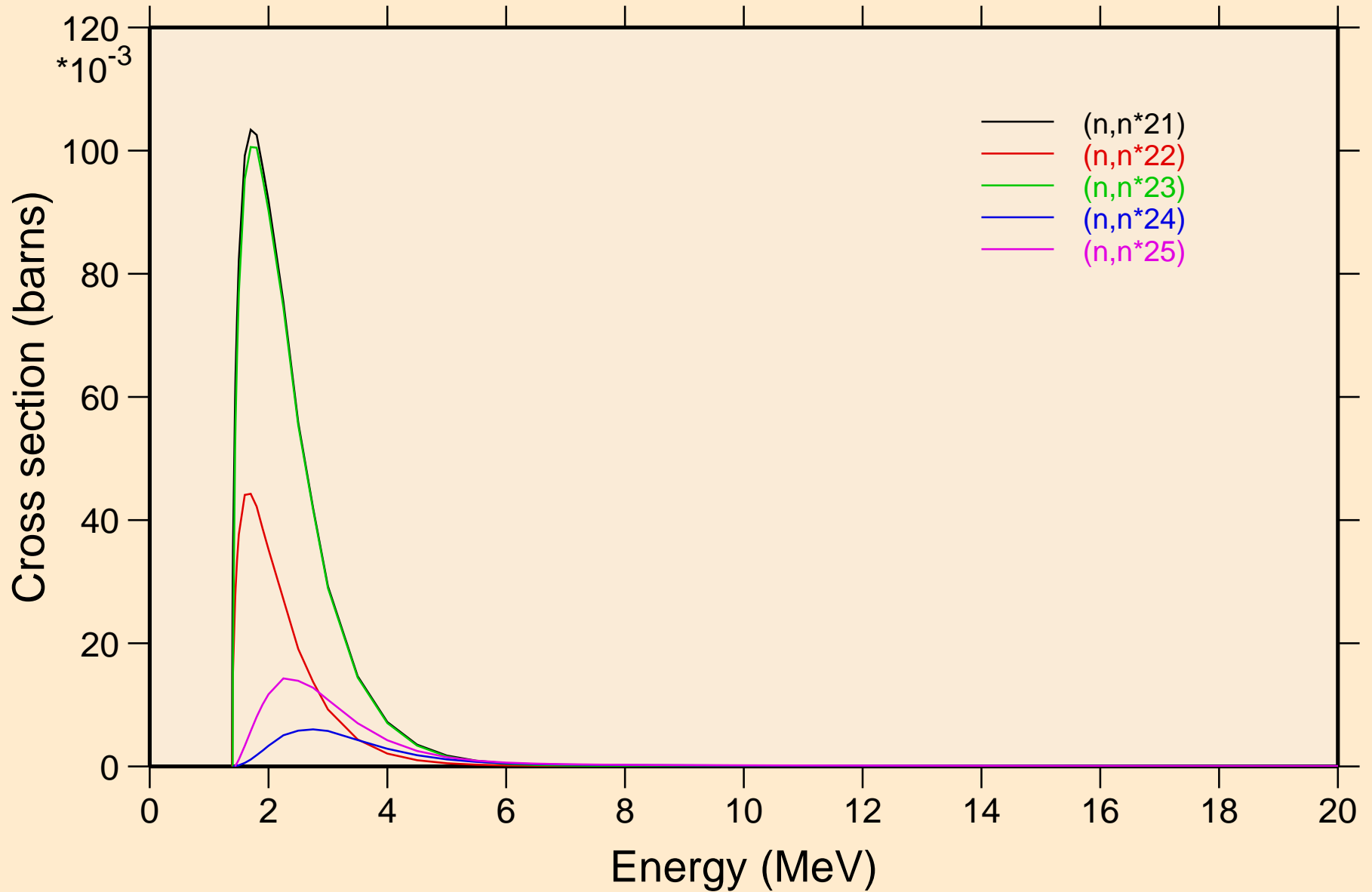

64-GD-160 FOR FENDL-3.1 FROM FENDL-3.1 WITH NJOY2012.50  
Inelastic levels

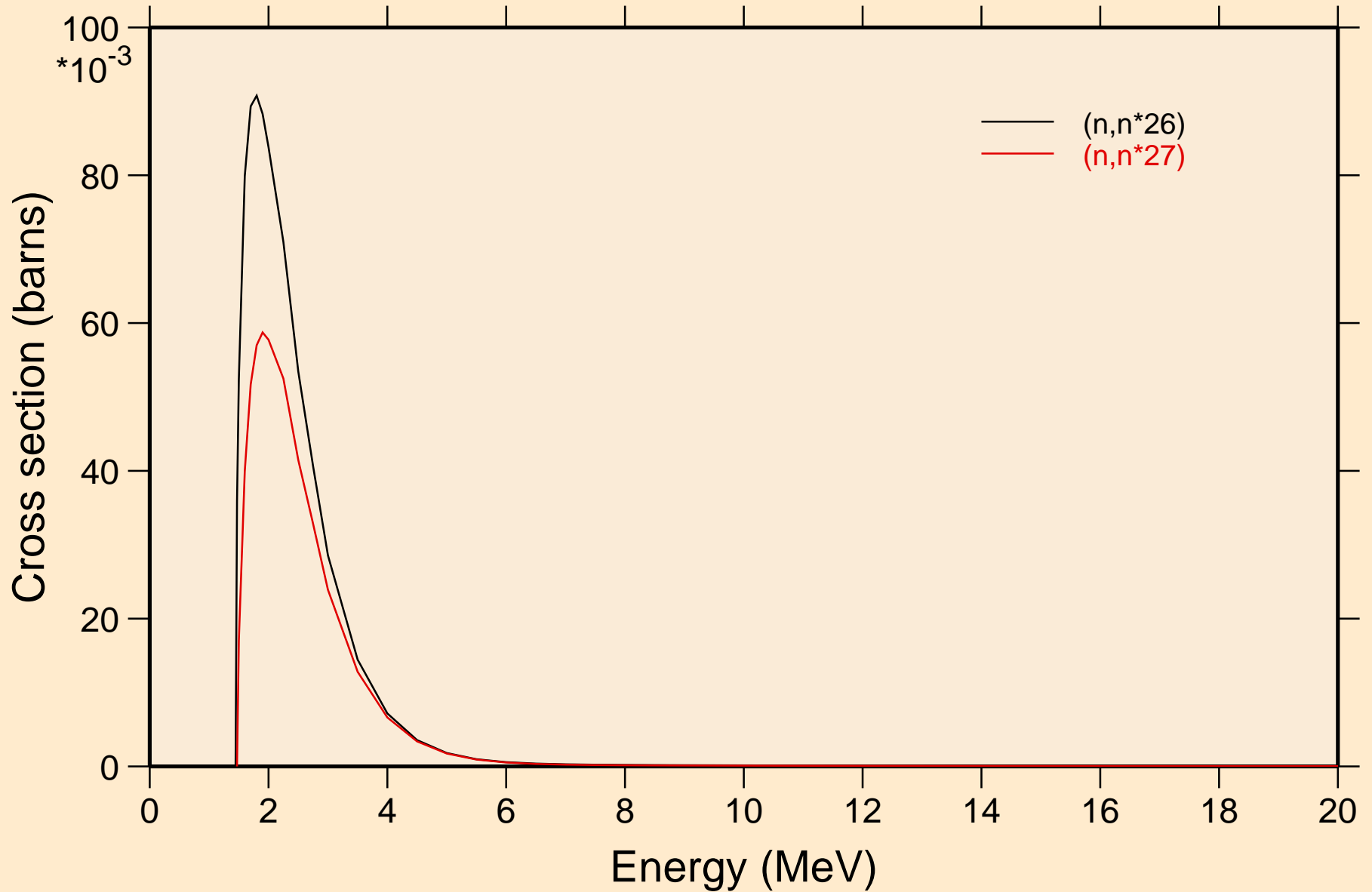

# 64-GD-160 FOR FENDL-3.1 FROM FENDL-3.1 WITH NJOY2012.50

## Threshold reactions

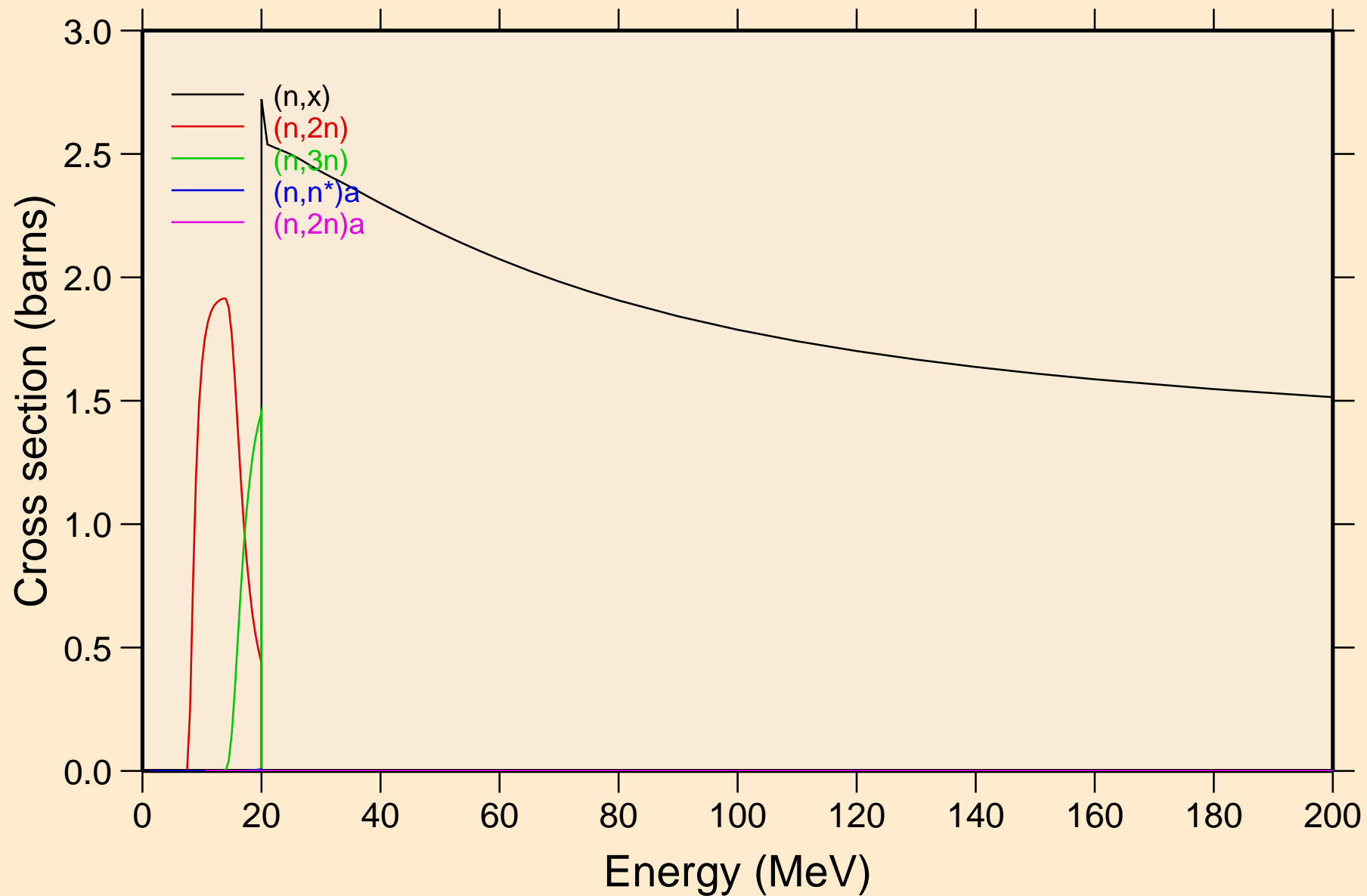



64-GD-160 FOR FENDL-3.1 FROM FENDL-3.1 WITH NJOY2012.50  
Threshold reactions

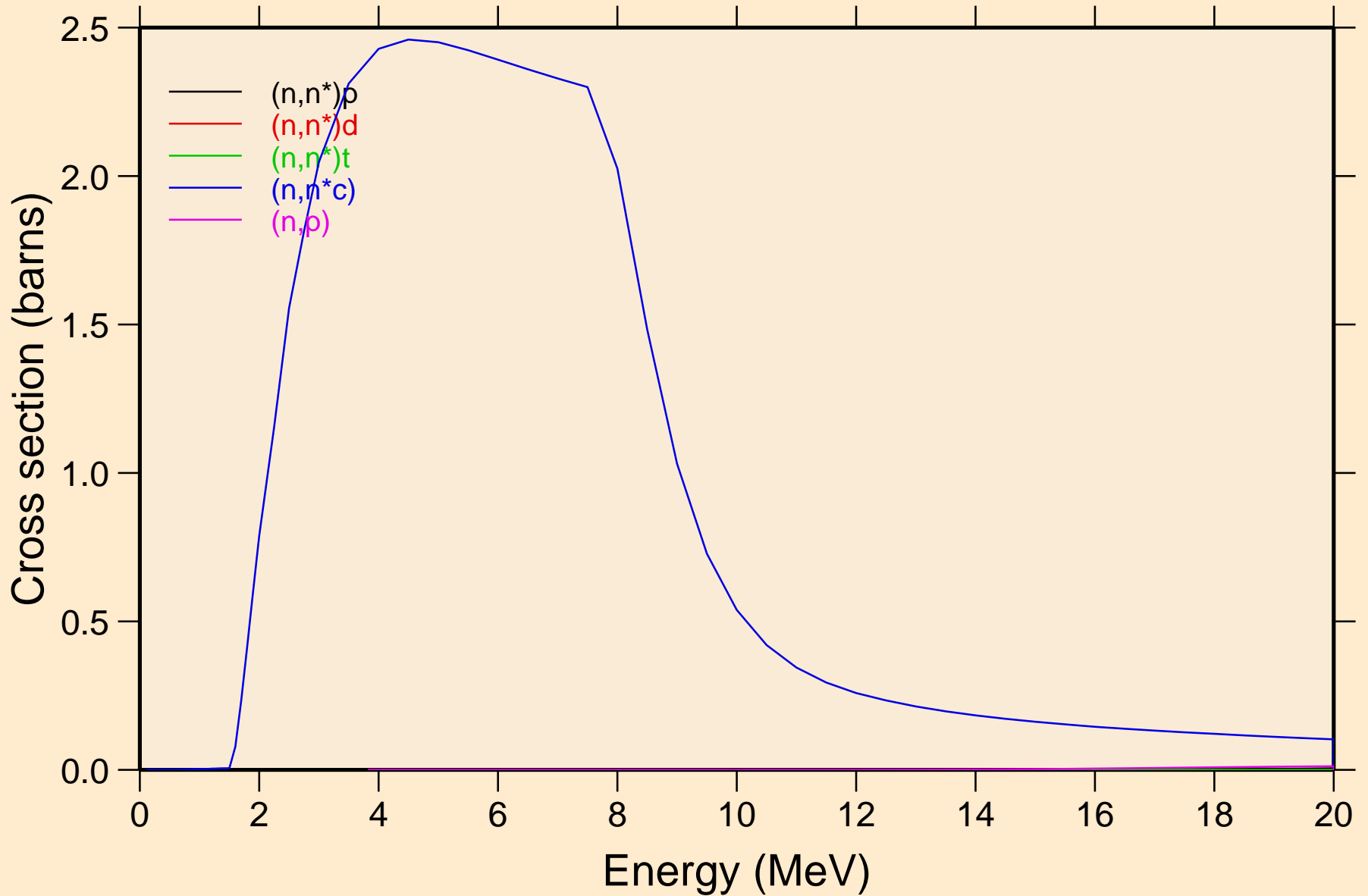

# 64-GD-160 FOR FENDL-3.1 FROM FENDL-3.1 WITH NJOY2012.50

## Threshold reactions

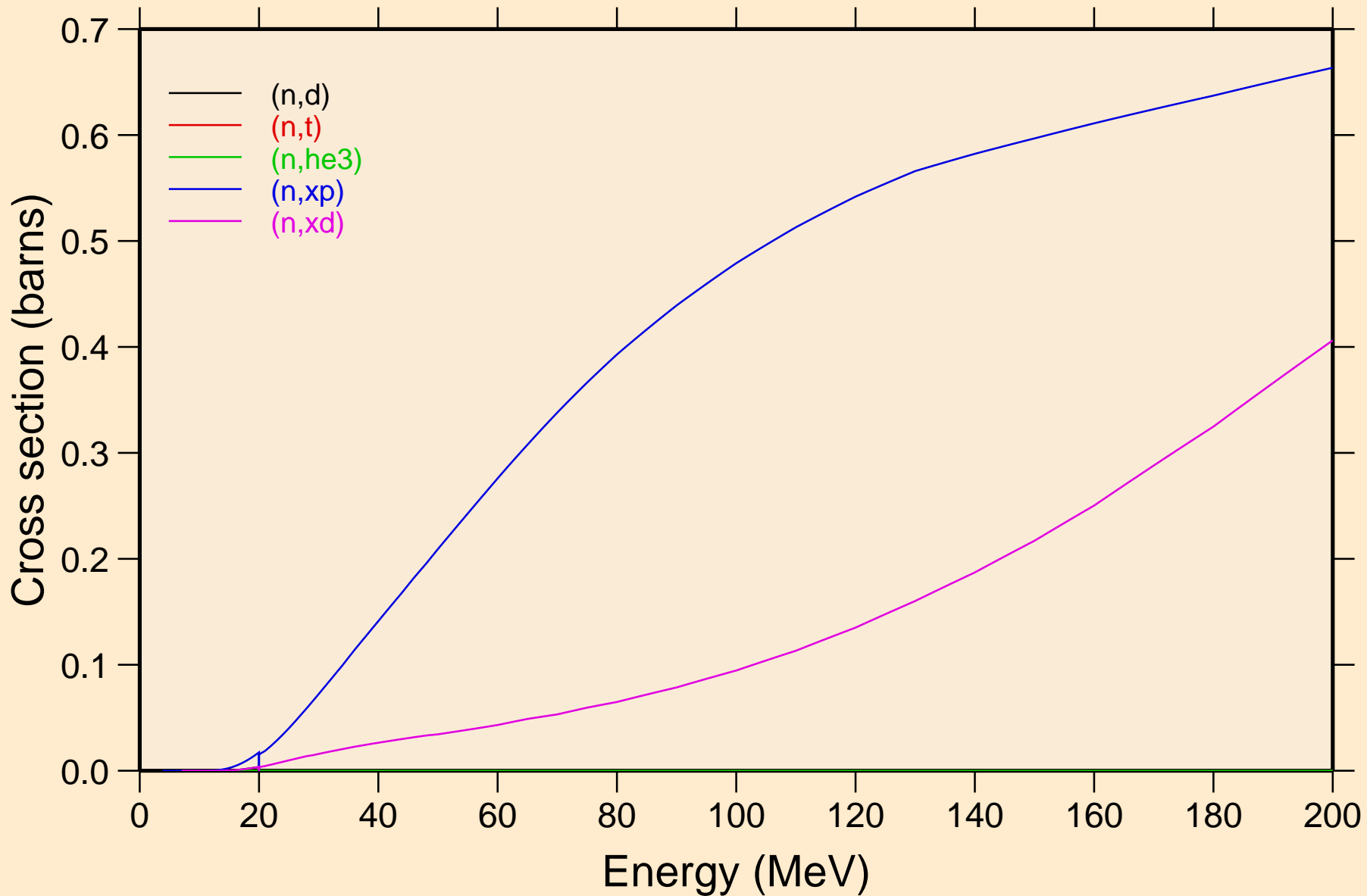

64-GD-160 FOR FENDL-3.1 FROM FENDL-3.1 WITH NJOY2012.50  
Threshold reactions

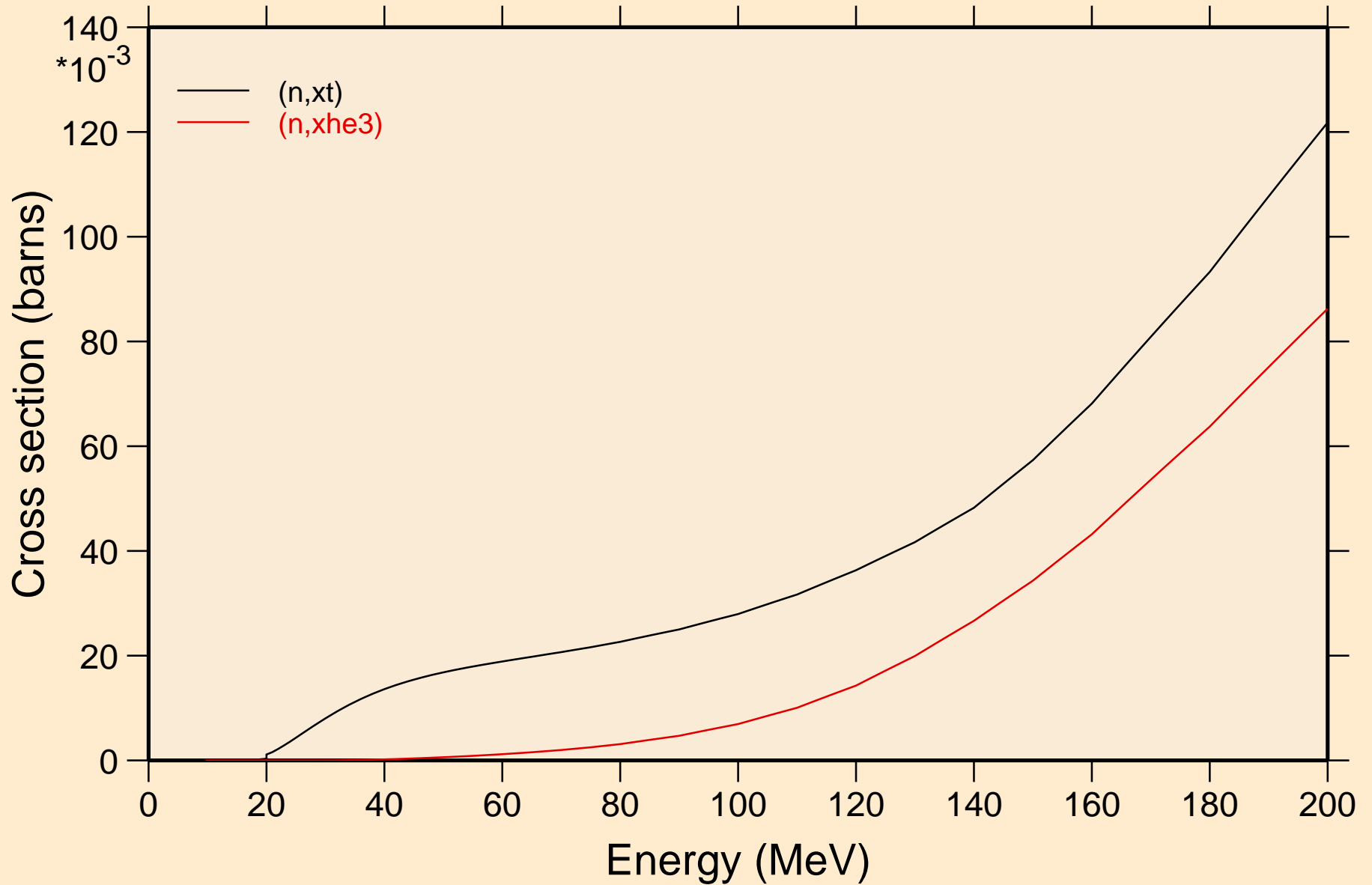

64-GD-160 FOR FENDL-3.1 FROM FENDL-3.1 WITH NJOY2012.50  
angular distribution for elastic

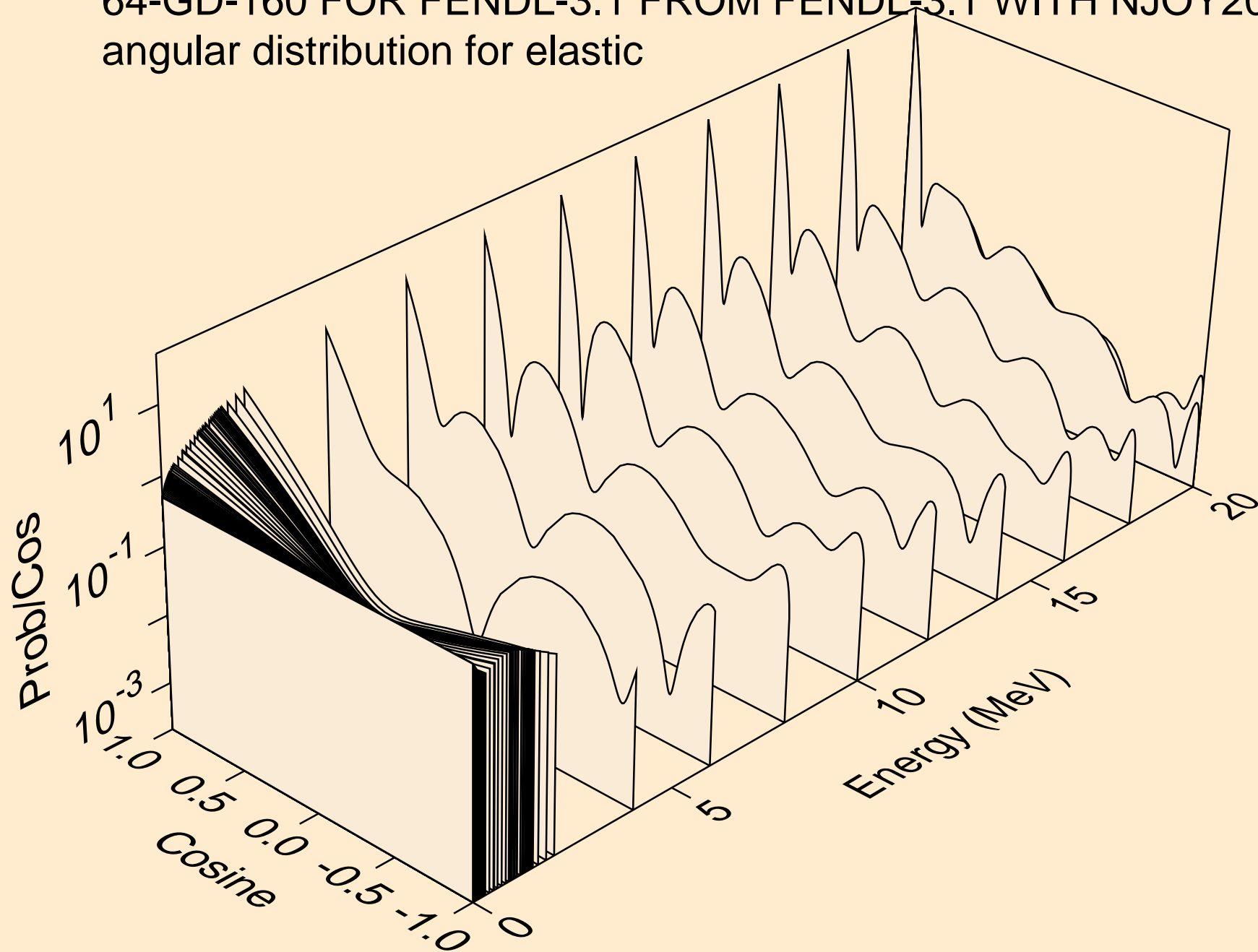

64-GD-160 FOR FENDL-3.1 FROM FENDL-3.1 WITH NJOY2012.50  
angular distribution for elastic

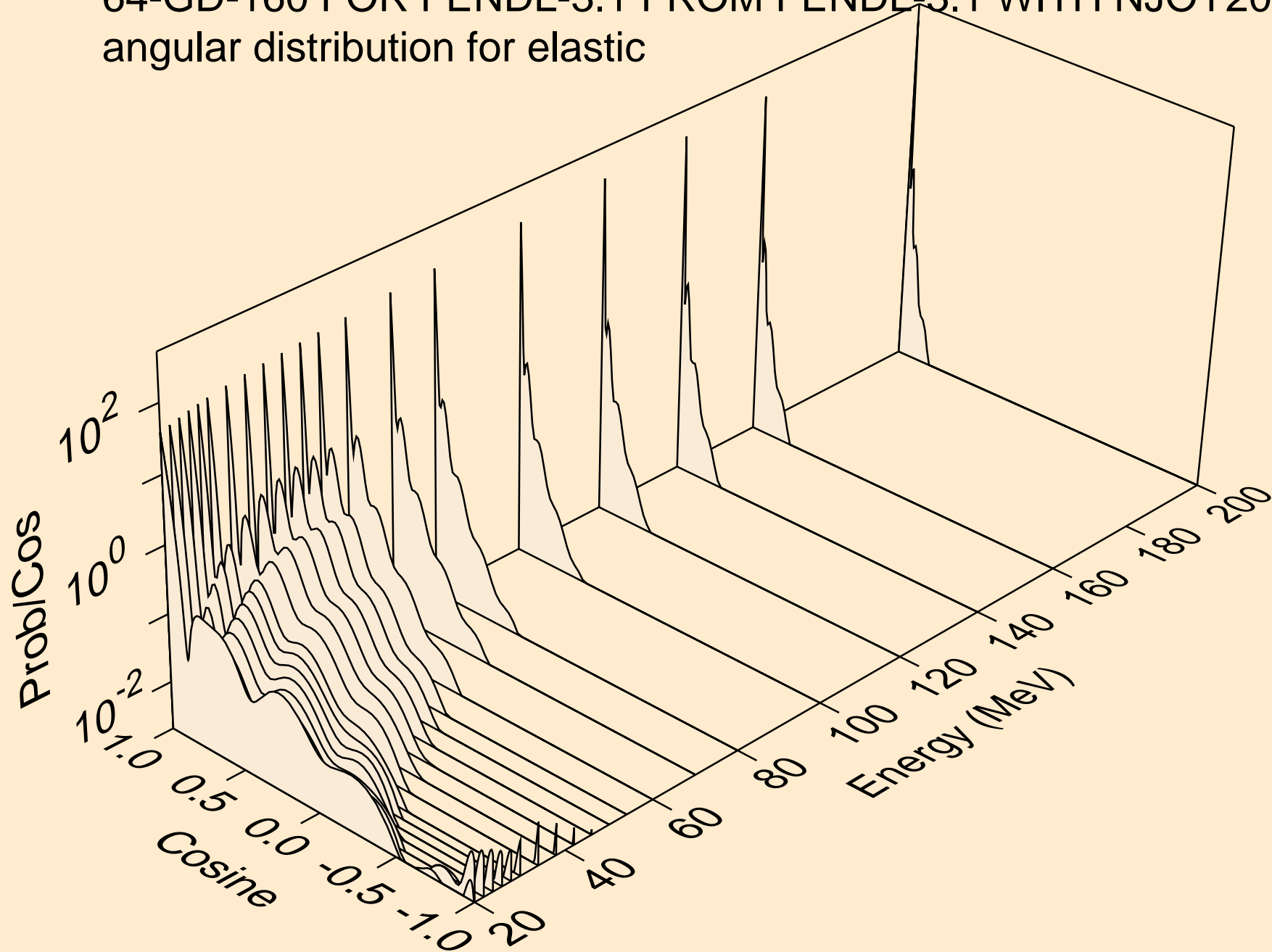

64-GD-160 FOR FENDL-3.1 FROM FENDL-3.1 WITH NJOY2012.50  
angular distribution for (n,n\*1)

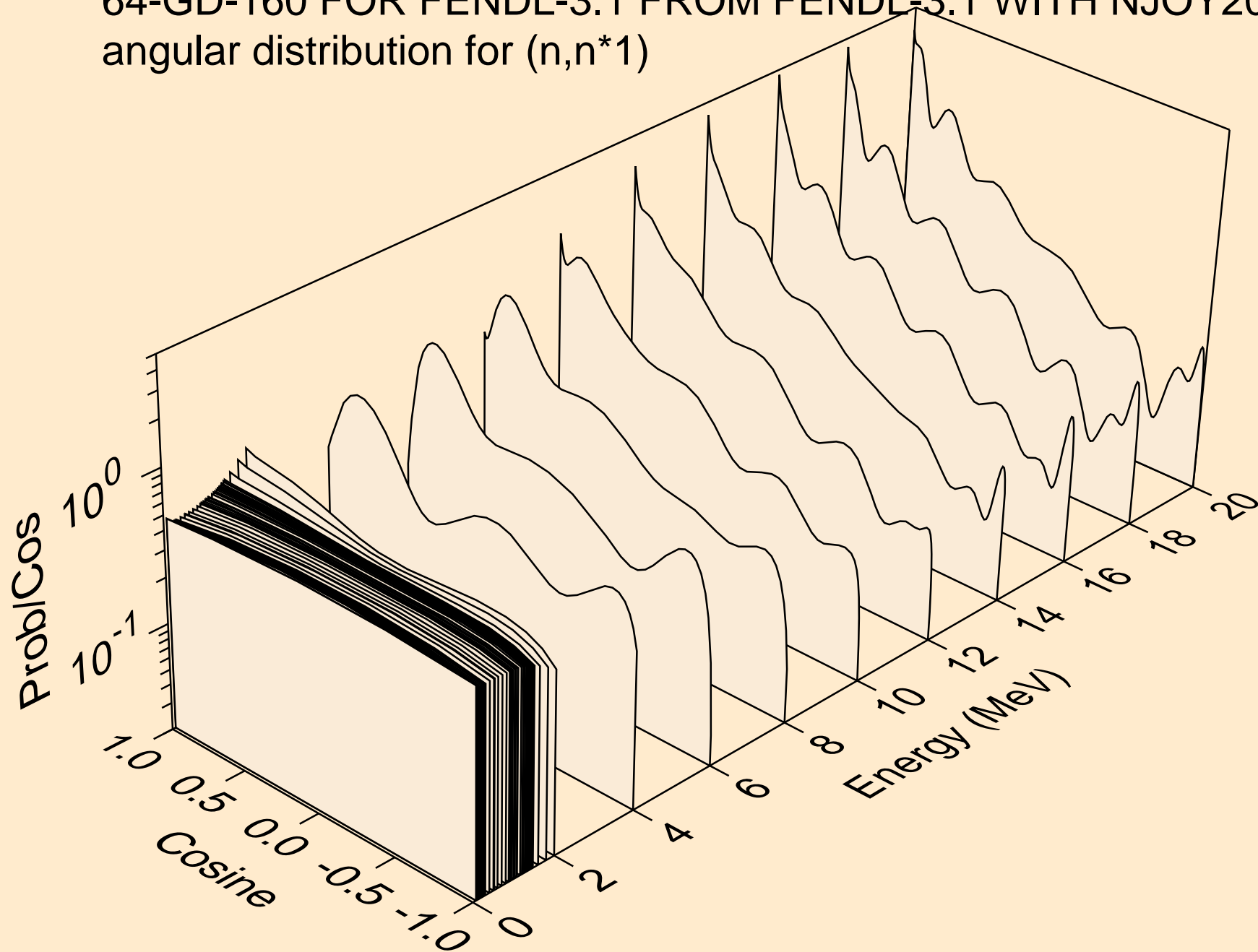

64-GD-160 FOR FENDL-3.1 FROM FENDL-3.1 WITH NJOY2012.50  
angular distribution for (n,n\*2)

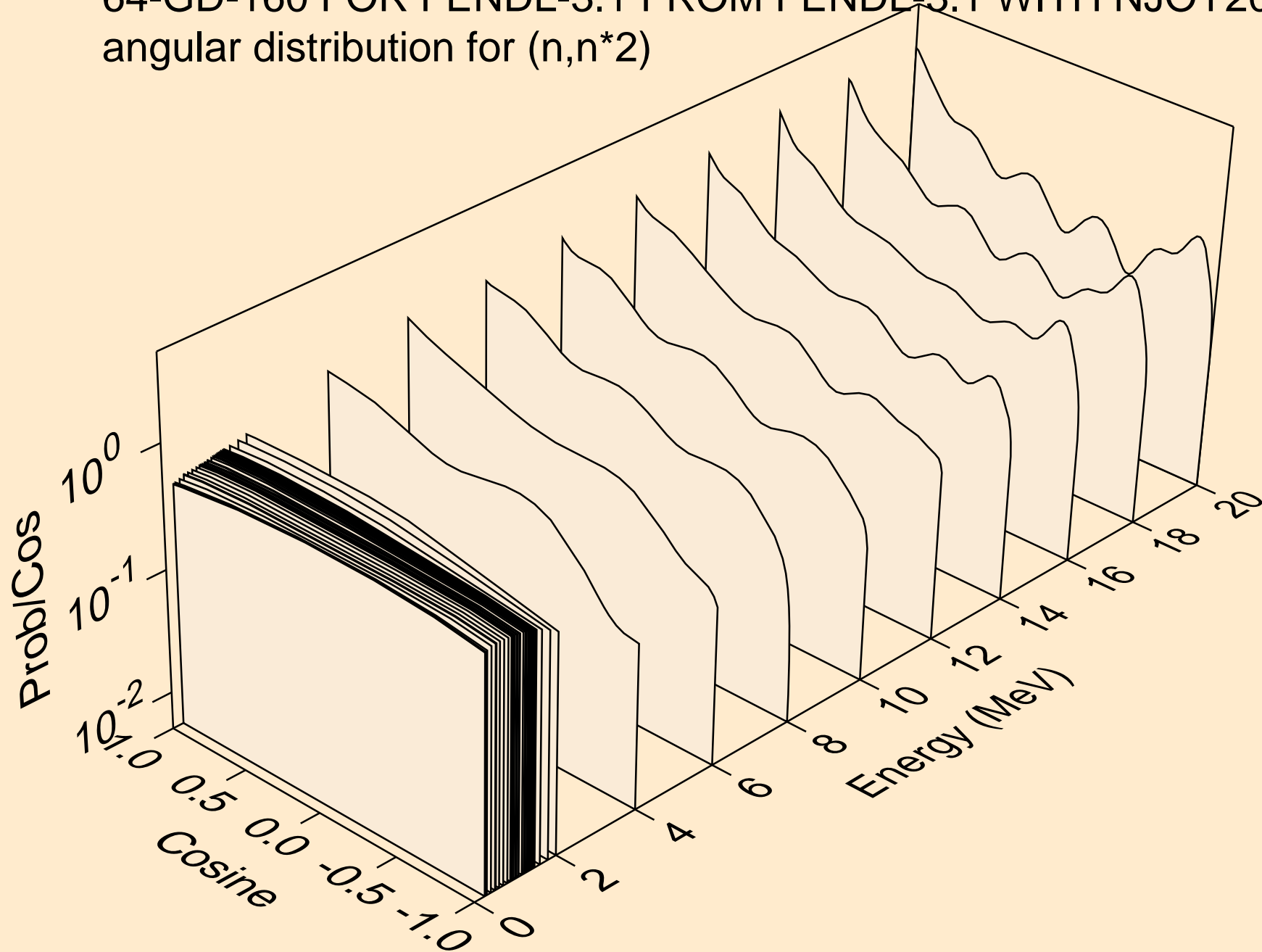

64-GD-160 FOR FENDL-3.1 FROM FENDL-3.1 WITH NJOY2012.50  
angular distribution for (n,n\*3)

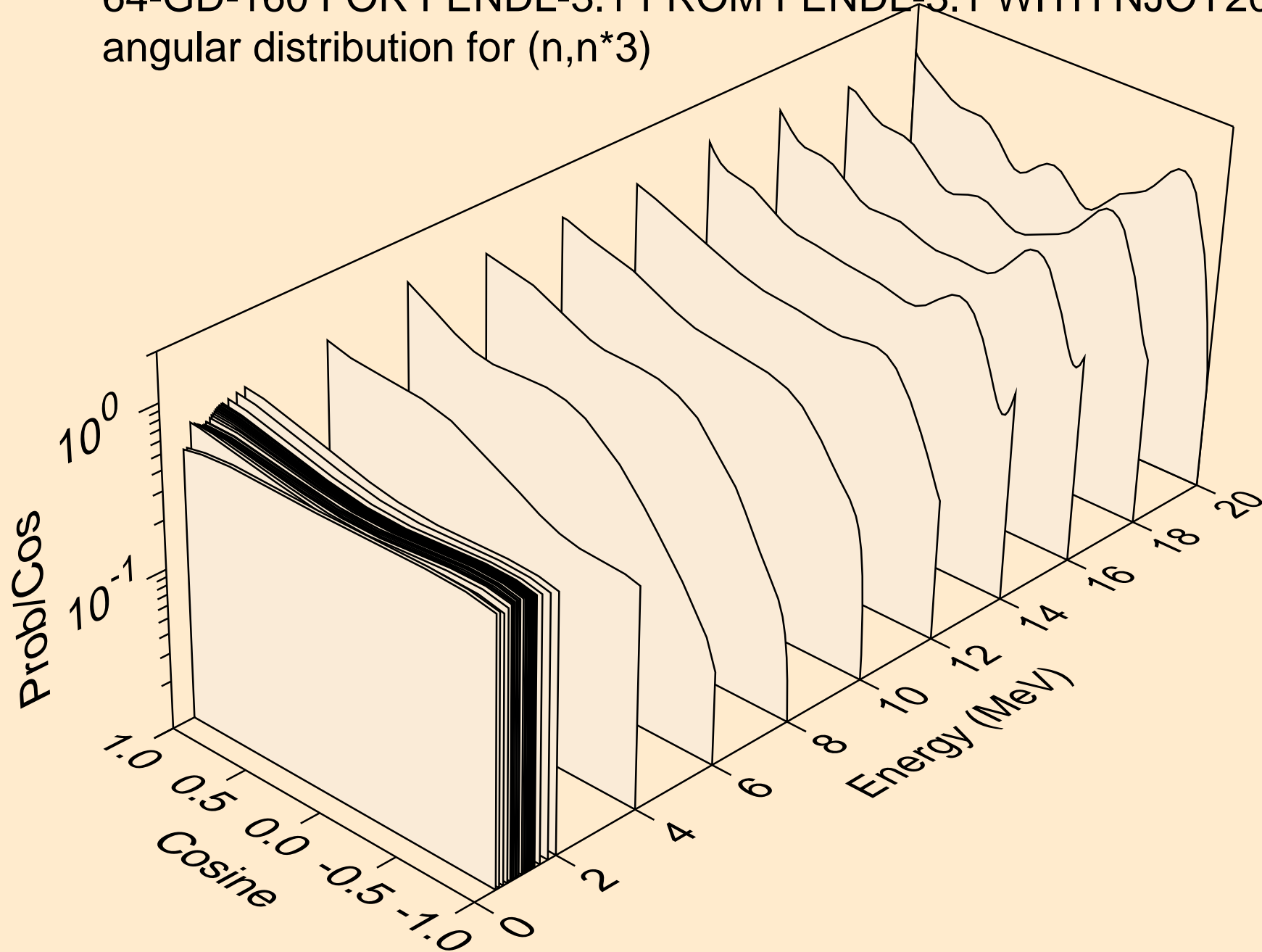



64-GD-160 FOR FENDL-3.1 FROM FENDL-3.1 WITH NJOY2012.50  
angular distribution for (n,n\*4)

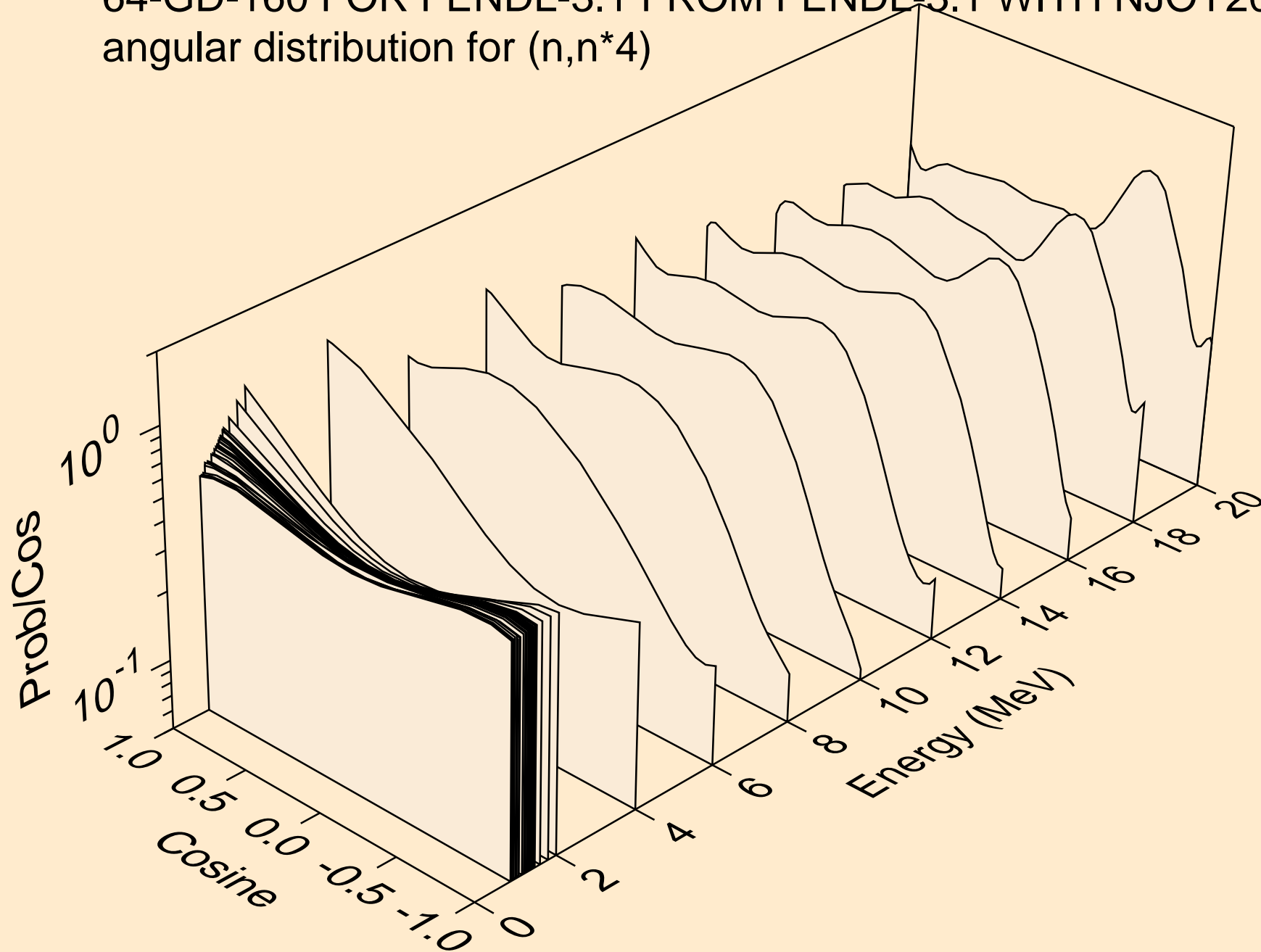

64-GD-160 FOR FENDL-3.1 FROM FENDL-3.1 WITH NJOY2012.50  
angular distribution for (n,n\*5)

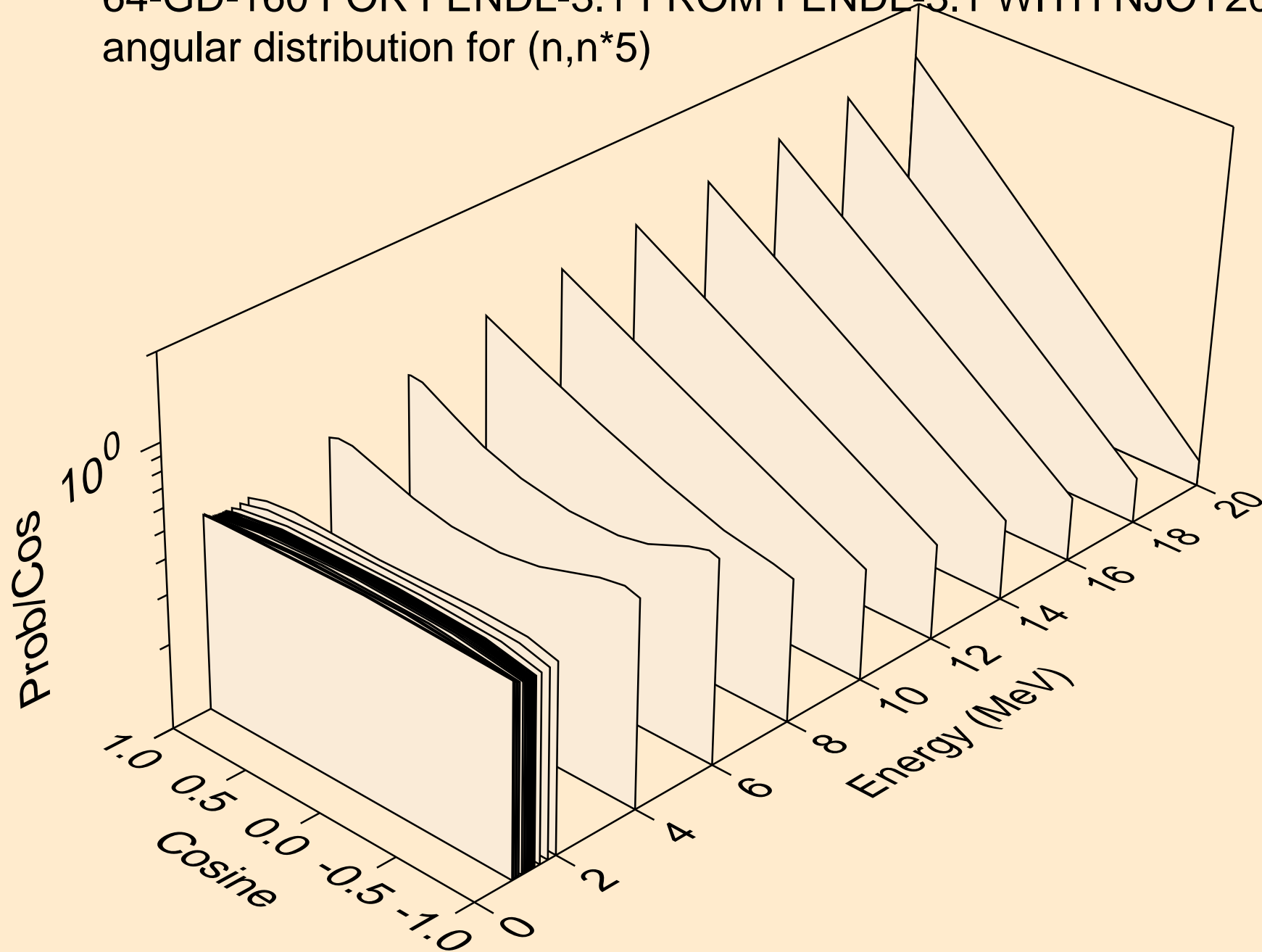

64-GD-160 FOR FENDL-3.1 FROM FENDL-3.1 WITH NJOY2012.50  
angular distribution for (n,n\*6)

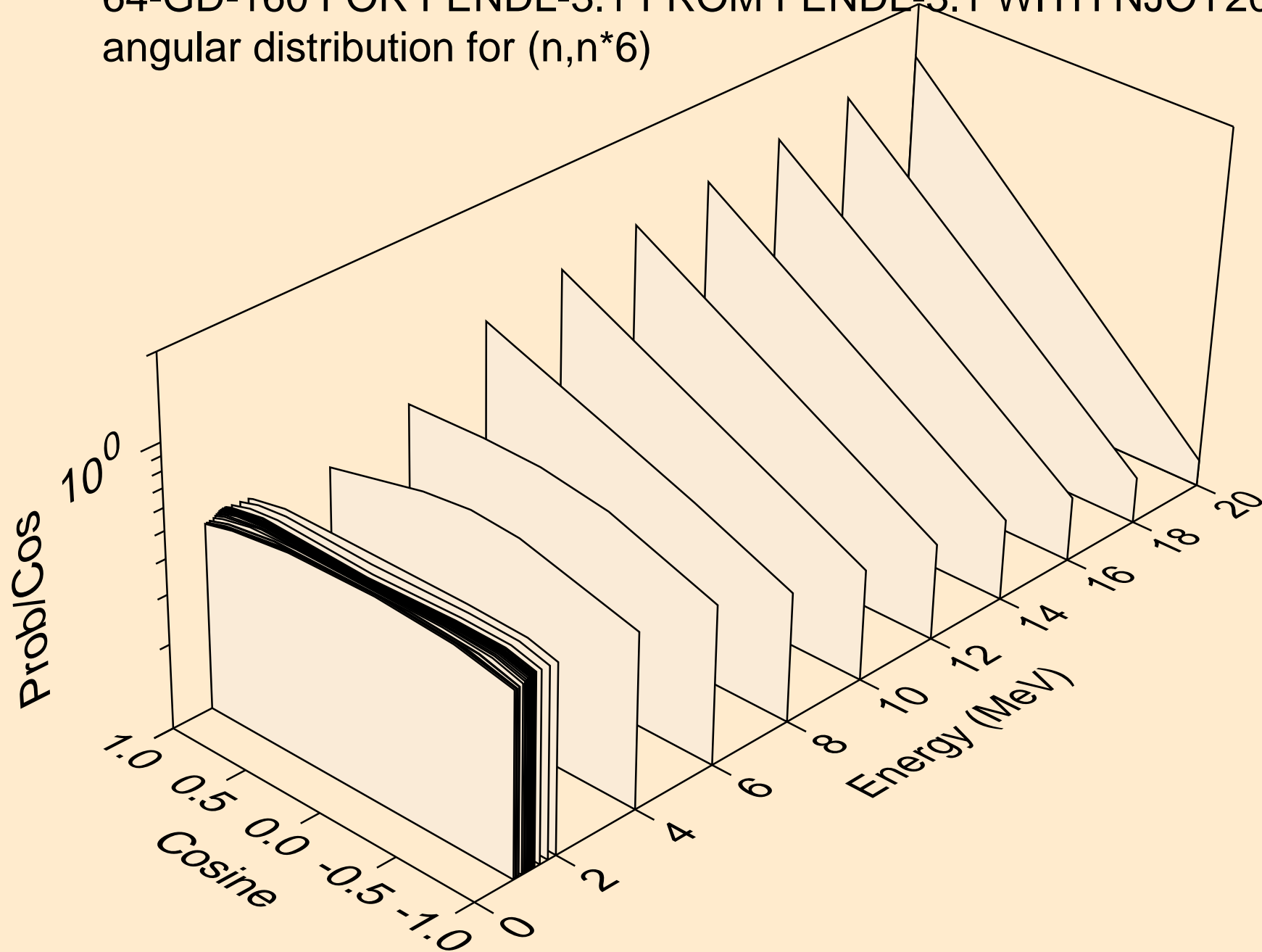

64-GD-160 FOR FENDL-3.1 FROM FENDL-3.1 WITH NJOY2012.50  
angular distribution for (n,n\*7)

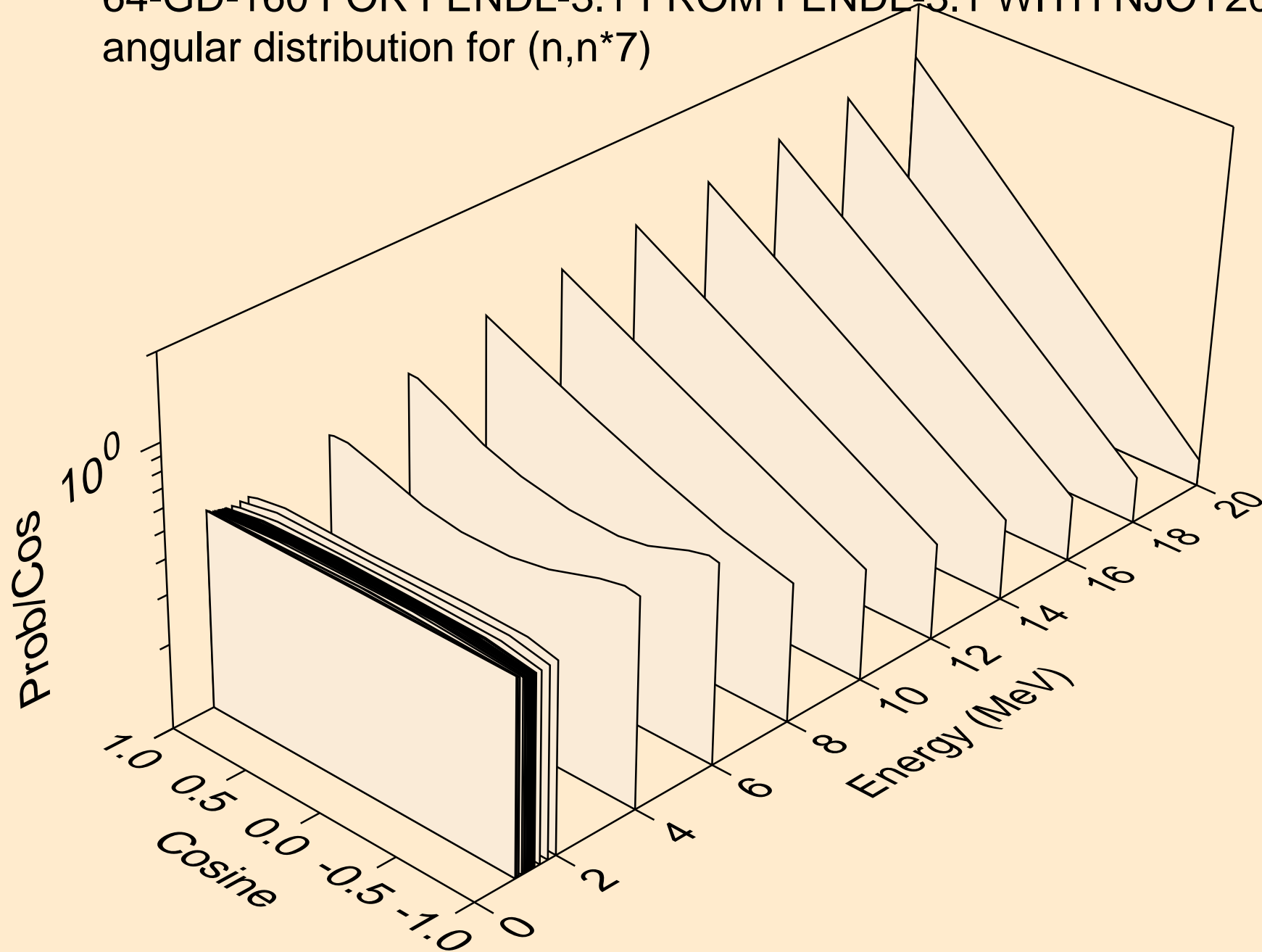

64-GD-160 FOR FENDL-3.1 FROM FENDL-3.1 WITH NJOY2012.50  
angular distribution for (n,n\*8)

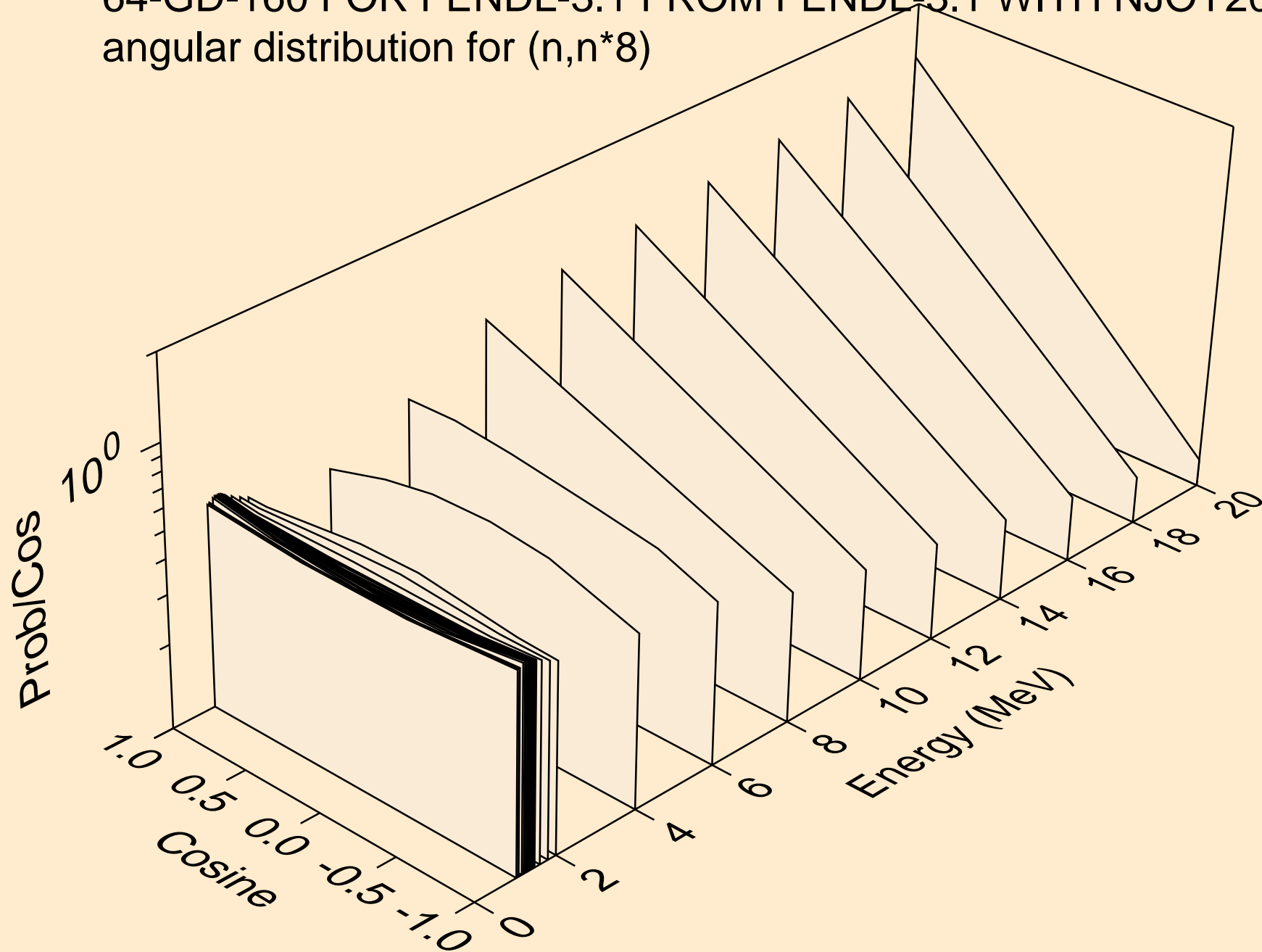

64-GD-160 FOR FENDL-3.1 FROM FENDL-3.1 WITH NJOY2012.50  
angular distribution for (n,n\*9)

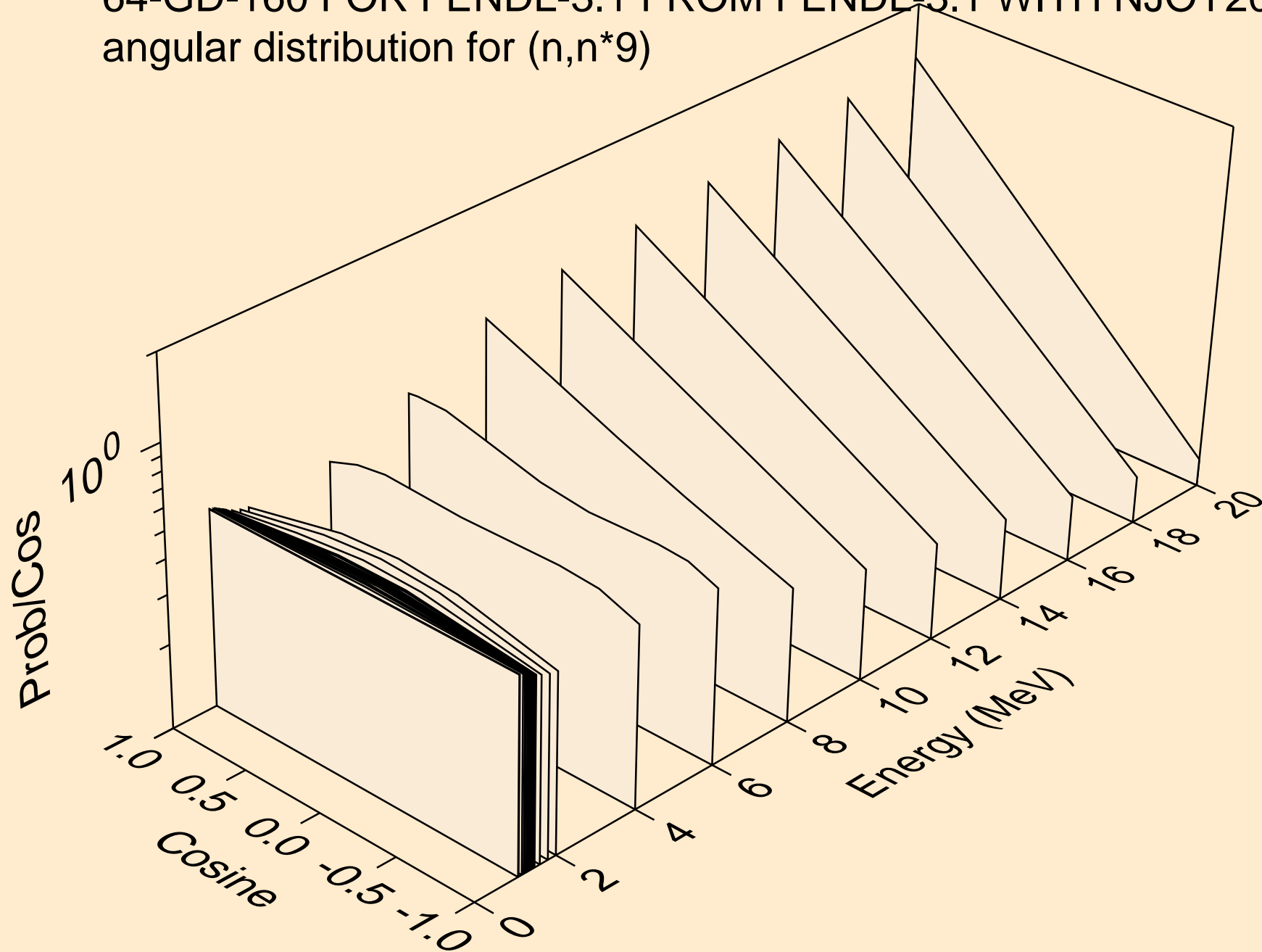

64-GD-160 FOR FENDL-3.1 FROM FENDL-3.1 WITH NJOY2012.50  
angular distribution for (n,n\*10)

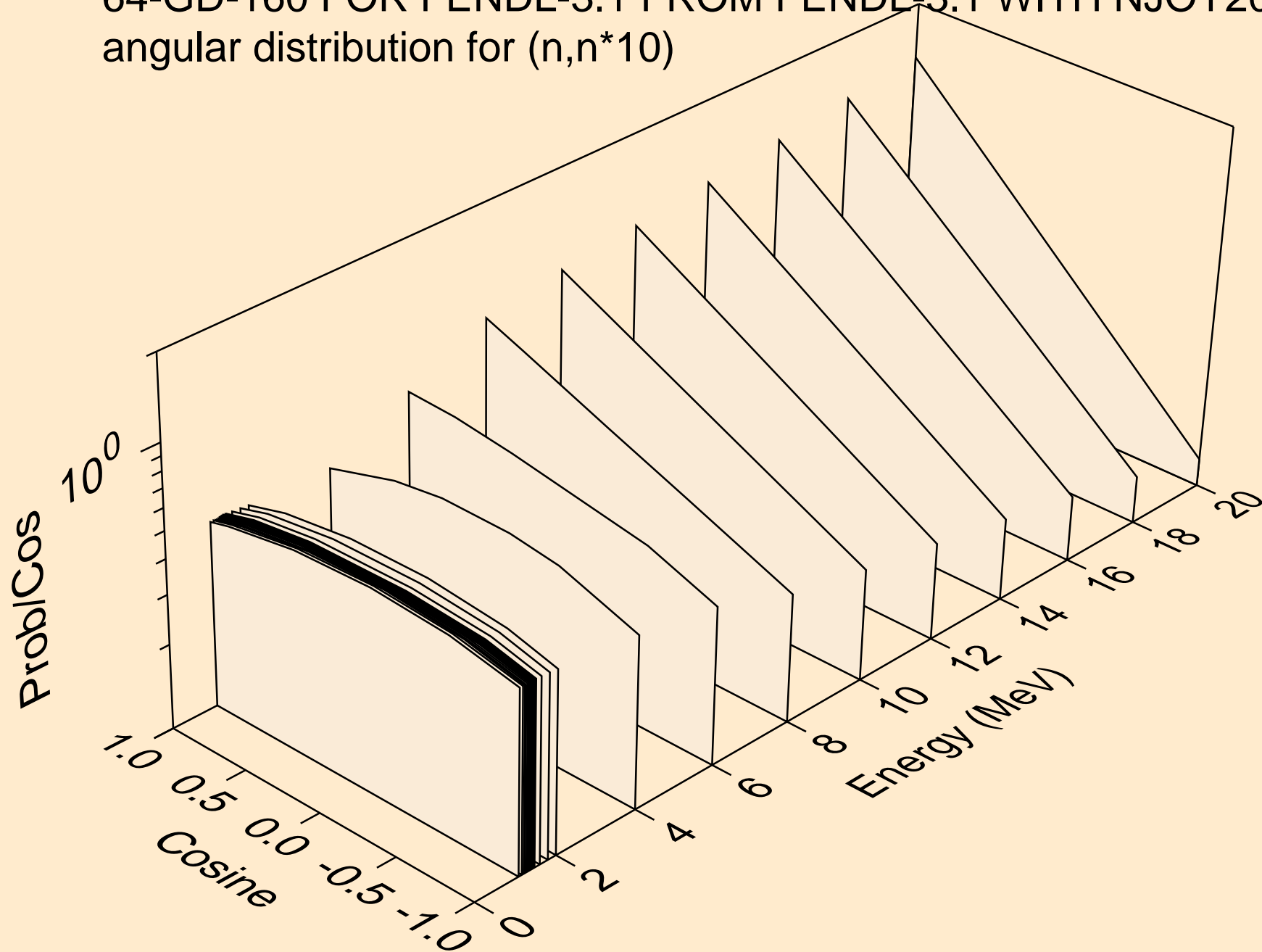

64-GD-160 FOR FENDL-3.1 FROM FENDL-3.1 WITH NJOY2012.50  
angular distribution for (n,n\*11)

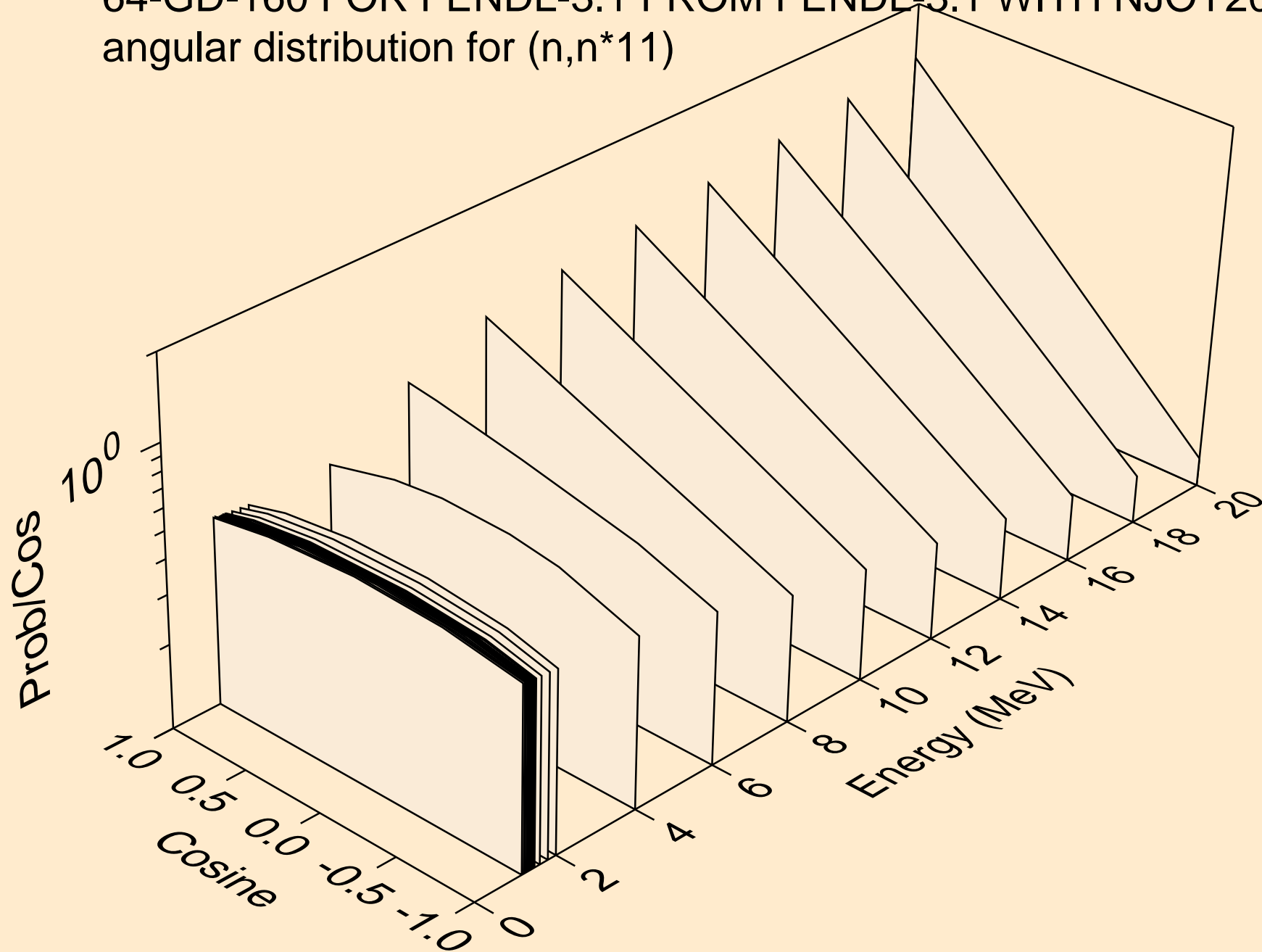



64-GD-160 FOR FENDL-3.1 FROM FENDL-3.1 WITH NJOY2012.50  
angular distribution for (n,n\*12)

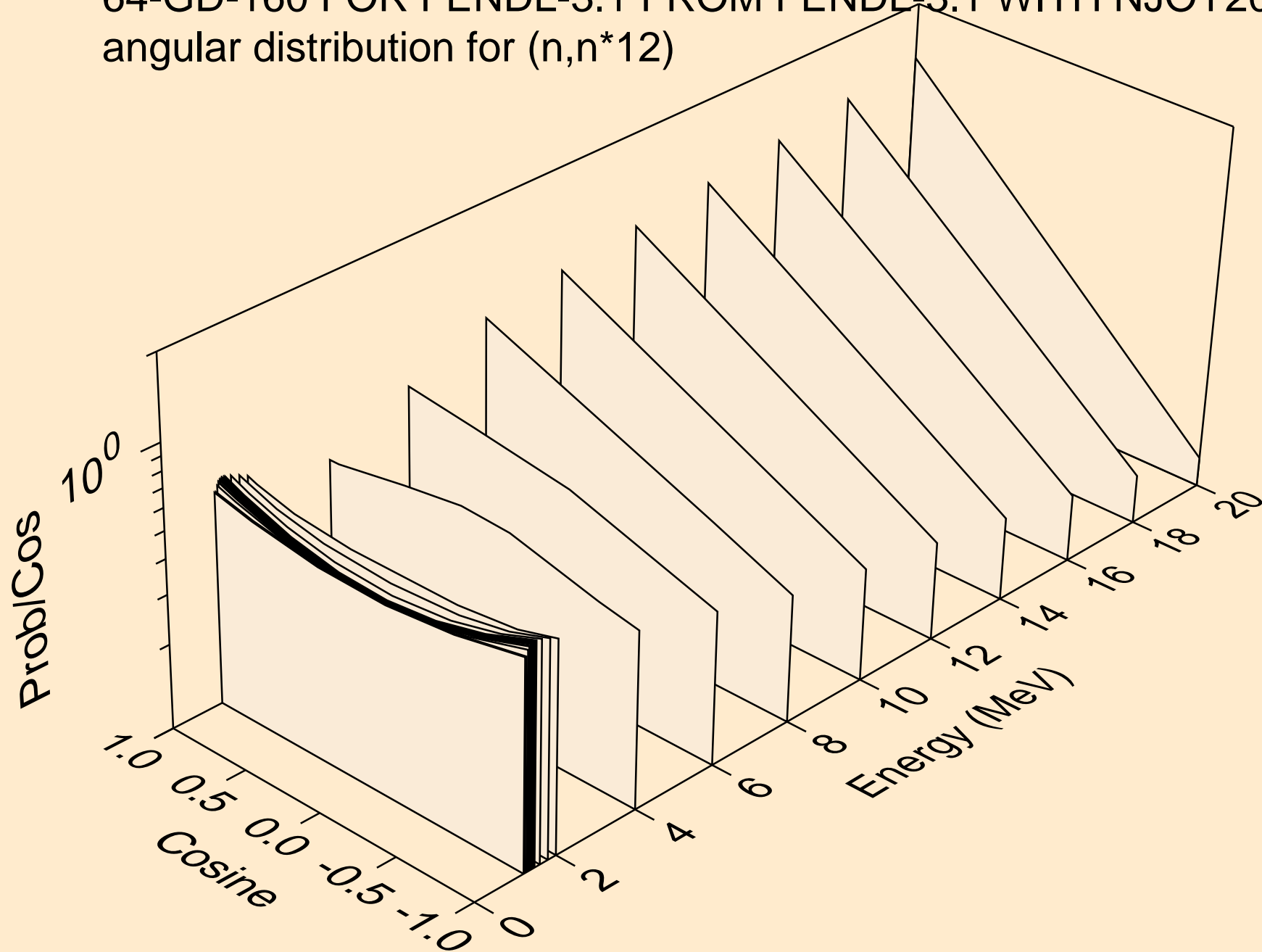

64-GD-160 FOR FENDL-3.1 FROM FENDL-3.1 WITH NJOY2012.50  
angular distribution for (n,n\*13)

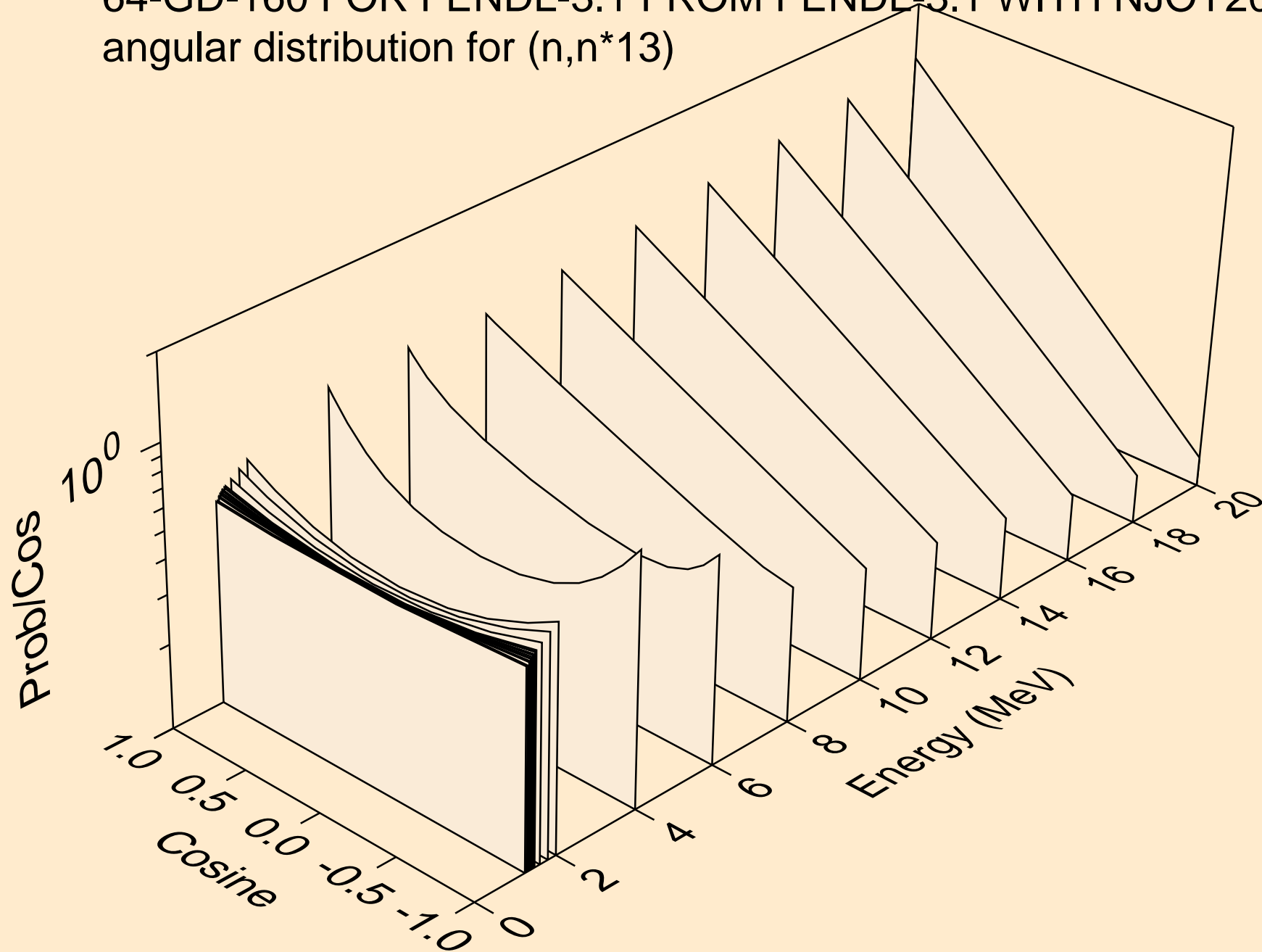

64-GD-160 FOR FENDL-3.1 FROM FENDL-3.1 WITH NJOY2012.50  
angular distribution for (n,n\*14)

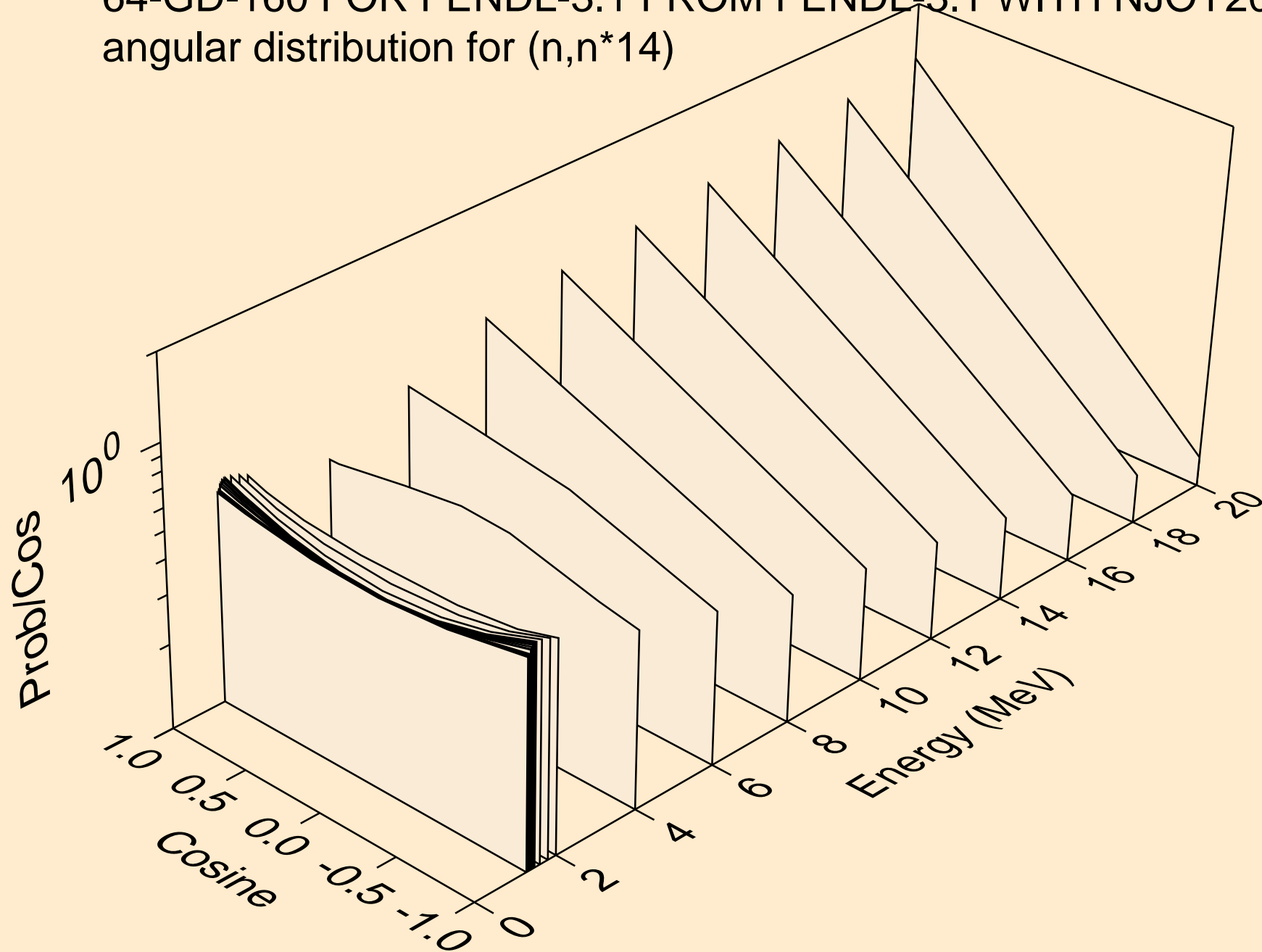

64-GD-160 FOR FENDL-3.1 FROM FENDL-3.1 WITH NJOY2012.50  
angular distribution for (n,n\*15)

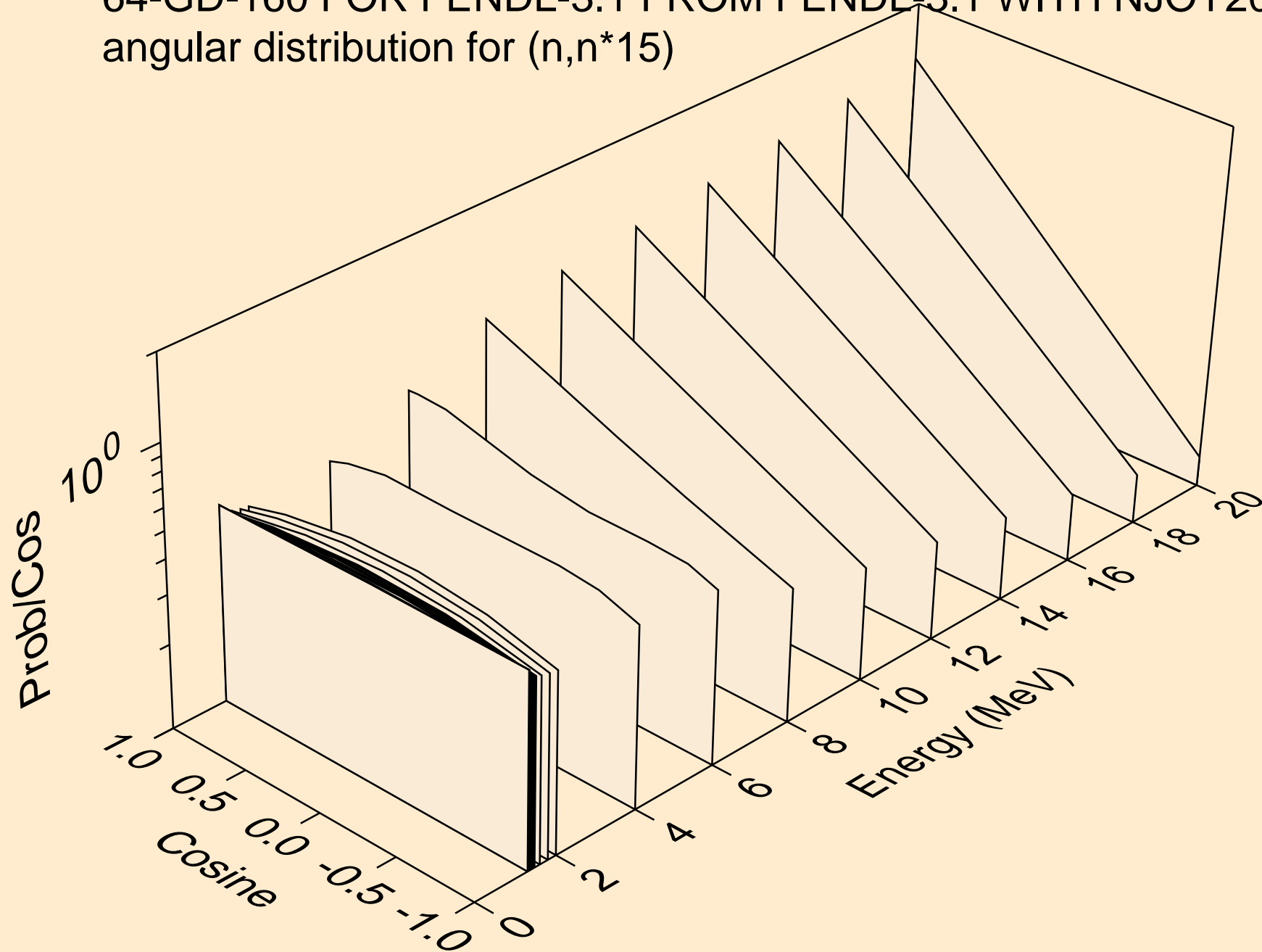

64-GD-160 FOR FENDL-3.1 FROM FENDL-3.1 WITH NJOY2012.50  
angular distribution for (n,n\*16)

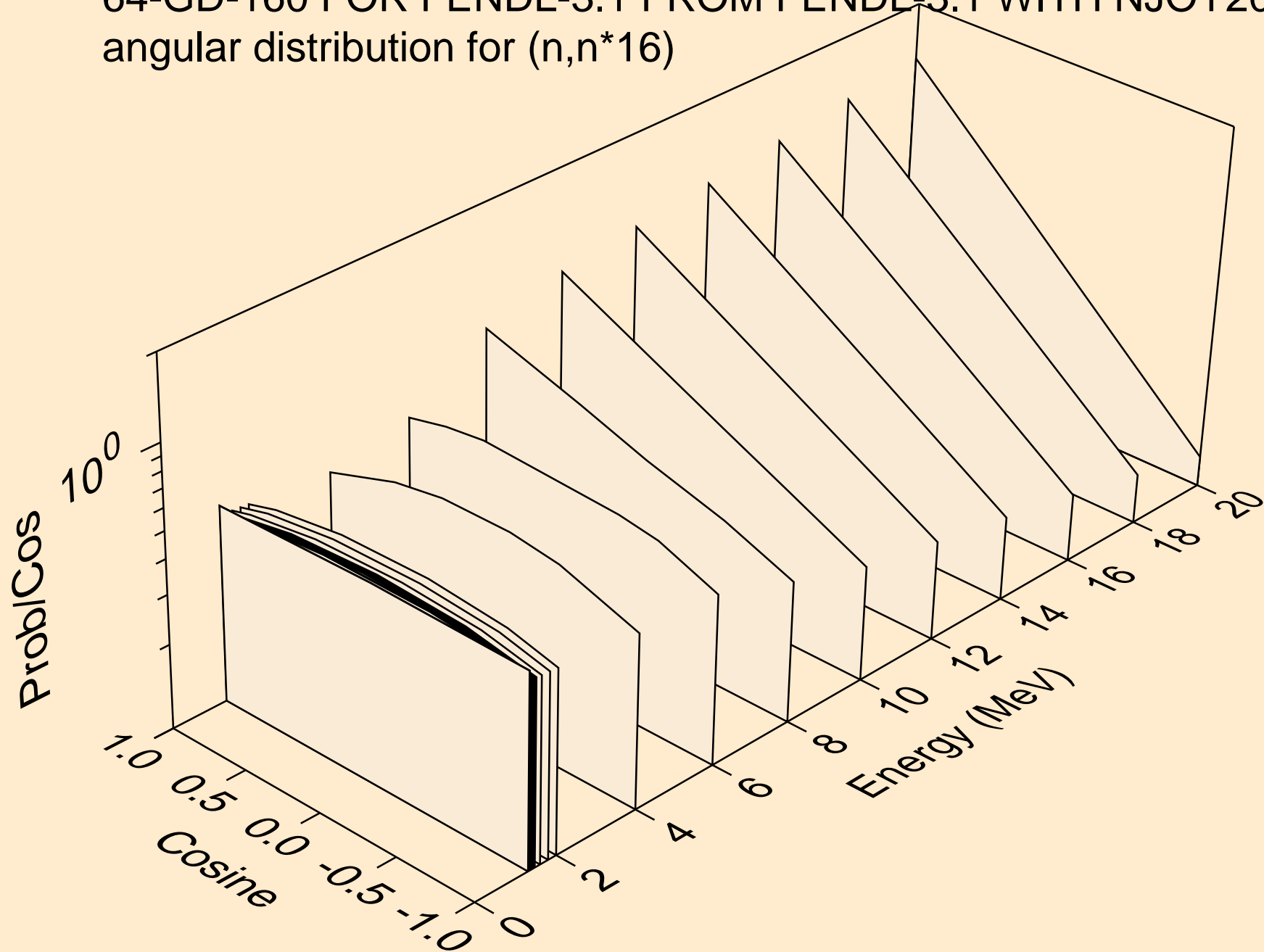

64-GD-160 FOR FENDL-3.1 FROM FENDL-3.1 WITH NJOY2012.50  
angular distribution for (n,n\*17)

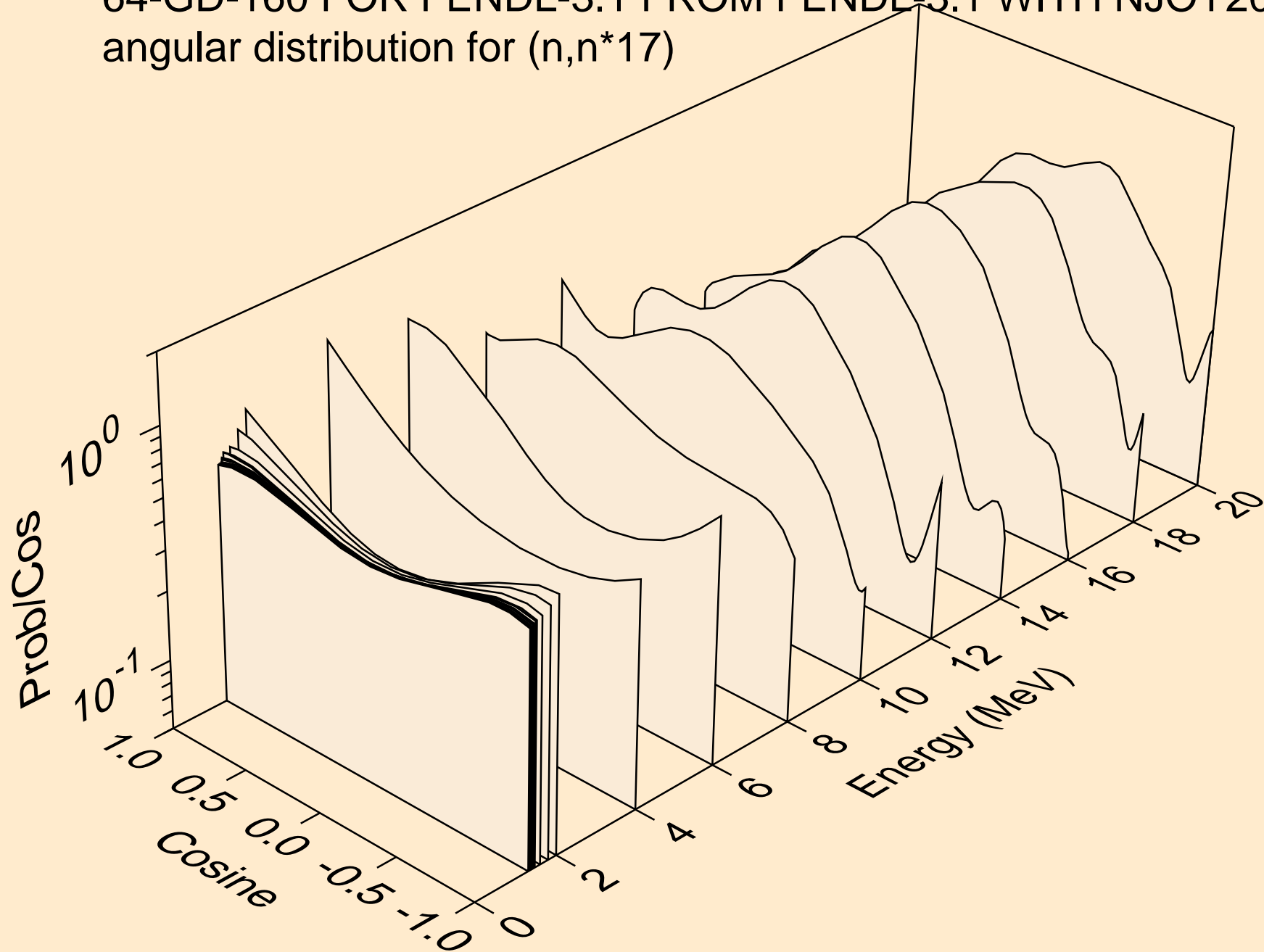

64-GD-160 FOR FENDL-3.1 FROM FENDL-3.1 WITH NJOY2012.50  
angular distribution for (n,n\*18)

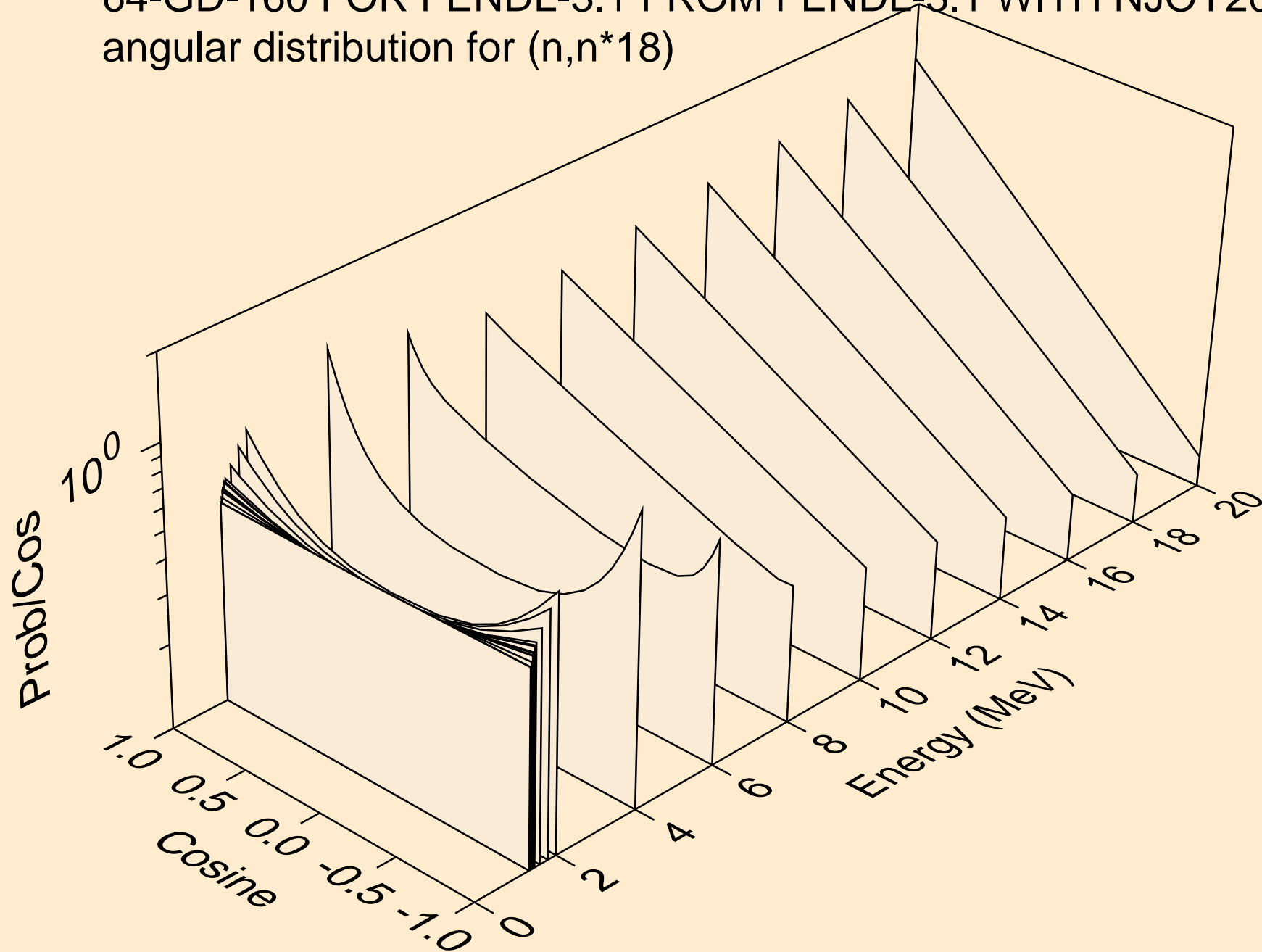

64-GD-160 FOR FENDL-3.1 FROM FENDL-3.1 WITH NJOY2012.50  
angular distribution for (n,n\*19)

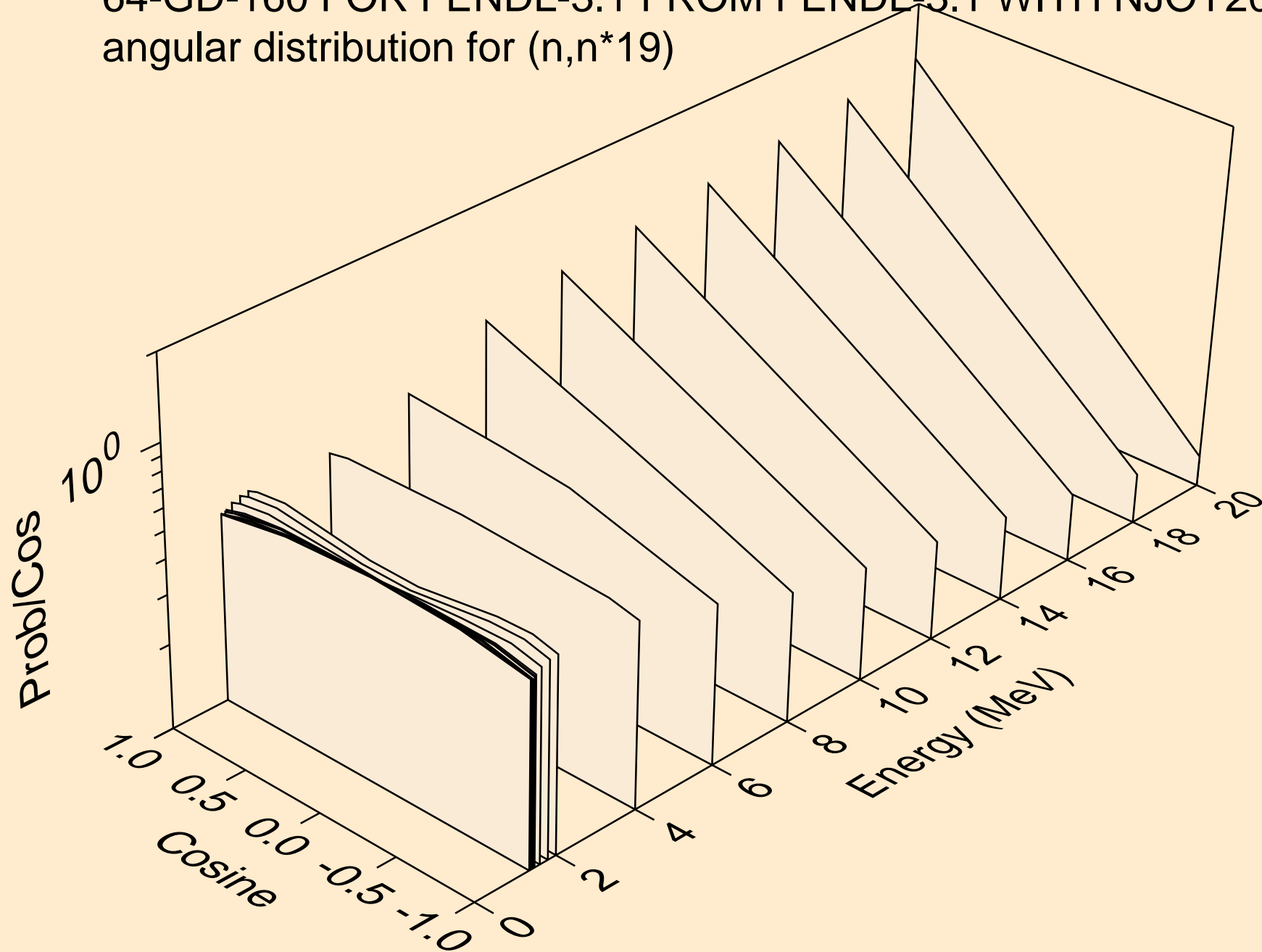



64-GD-160 FOR FENDL-3.1 FROM FENDL-3.1 WITH NJOY2012.50  
angular distribution for (n,n\*20)

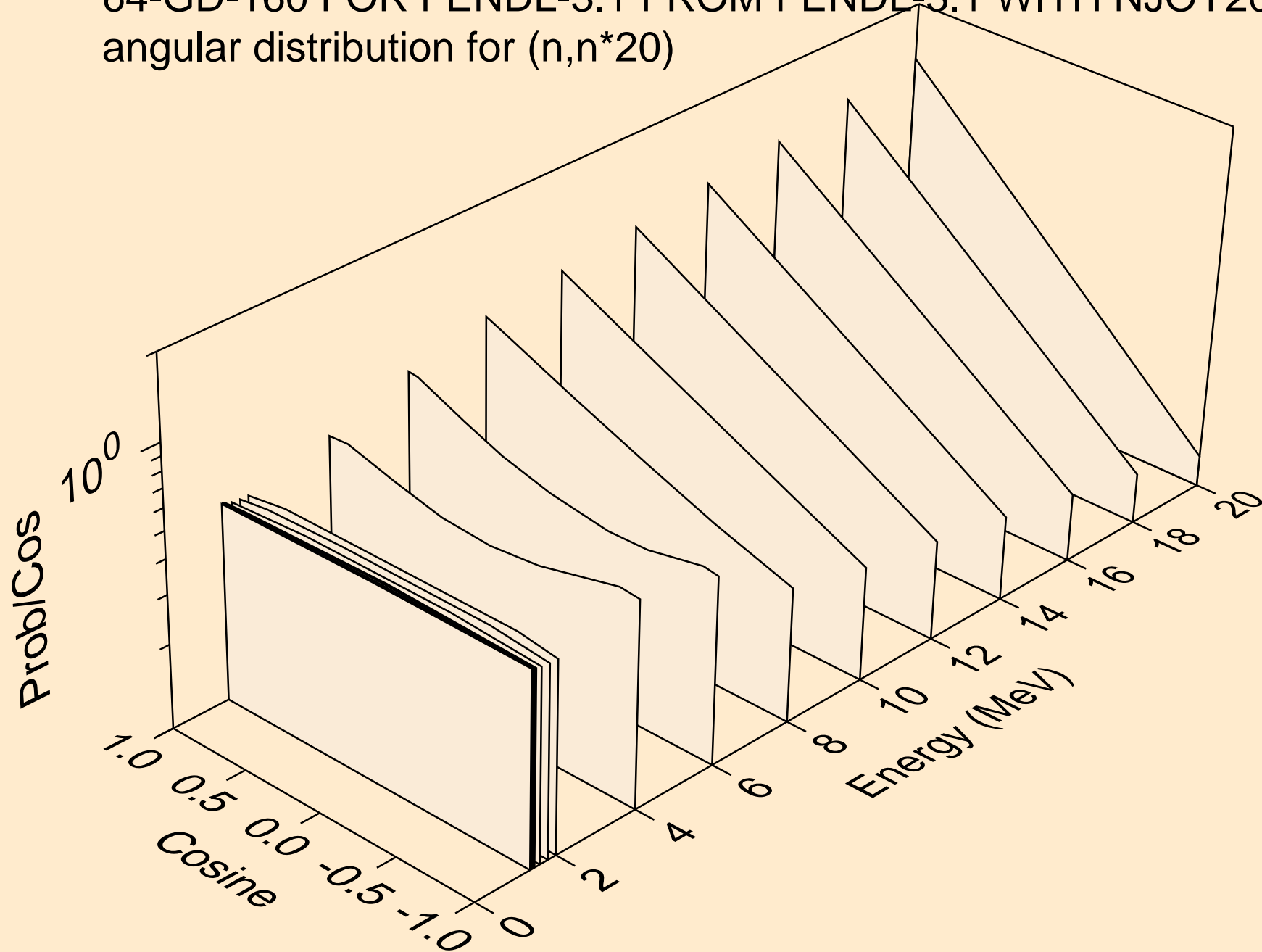

64-GD-160 FOR FENDL-3.1 FROM FENDL-3.1 WITH NJOY2012.50  
angular distribution for (n,n\*21)

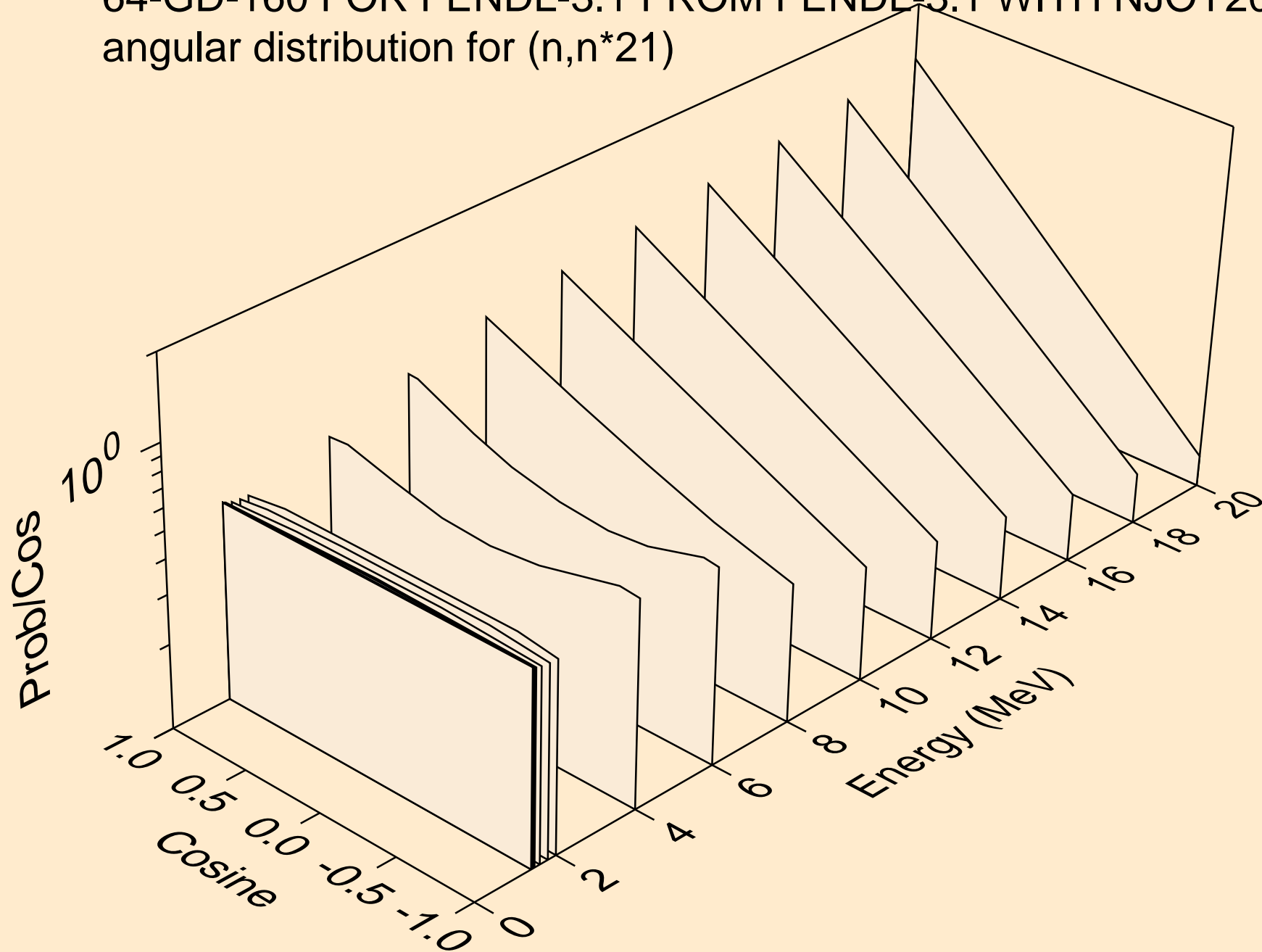

64-GD-160 FOR FENDL-3.1 FROM FENDL-3.1 WITH NJOY2012.50  
angular distribution for (n,n\*22)

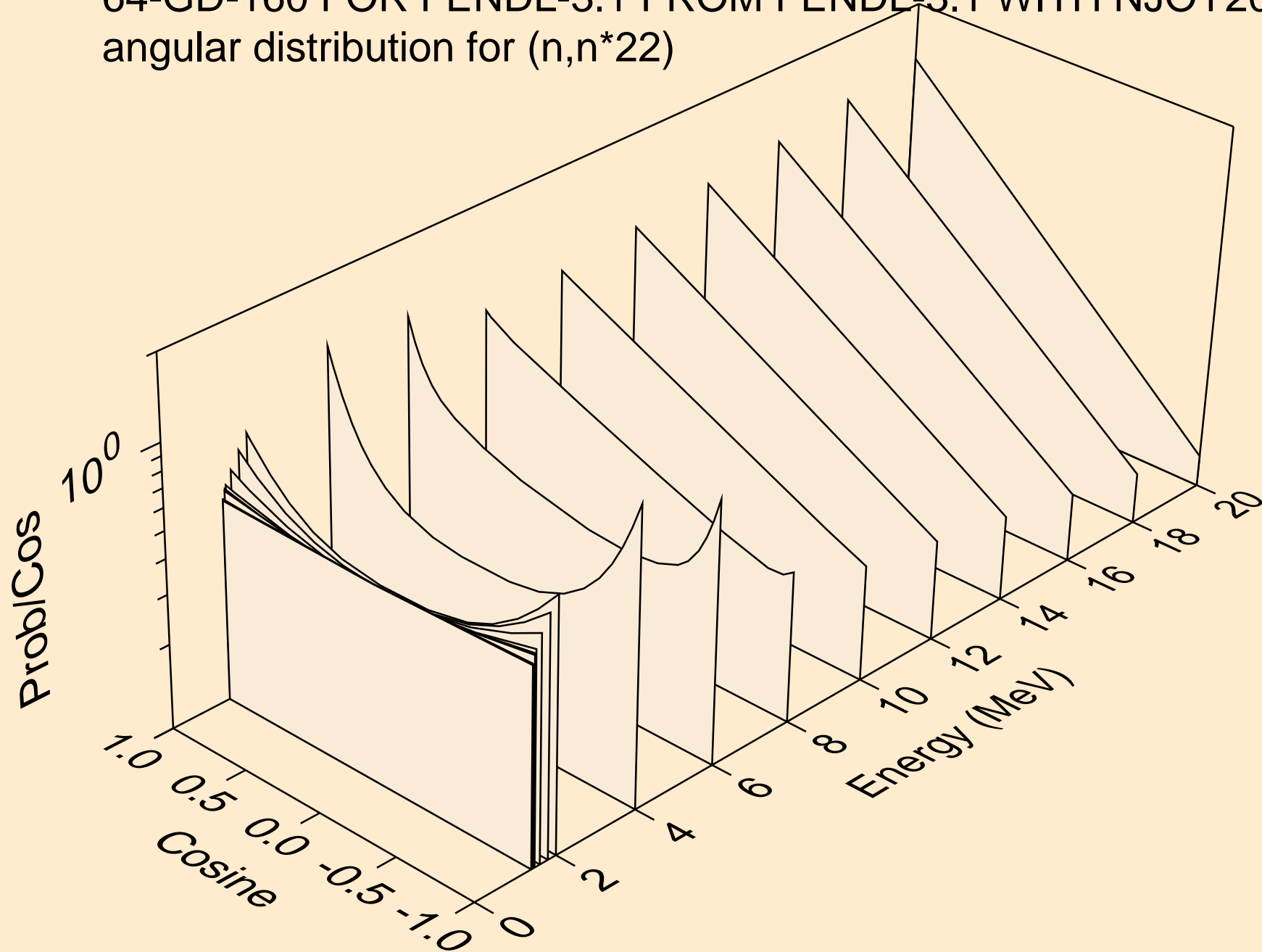

64-GD-160 FOR FENDL-3.1 FROM FENDL-3.1 WITH NJOY2012.50  
angular distribution for (n,n\*23)

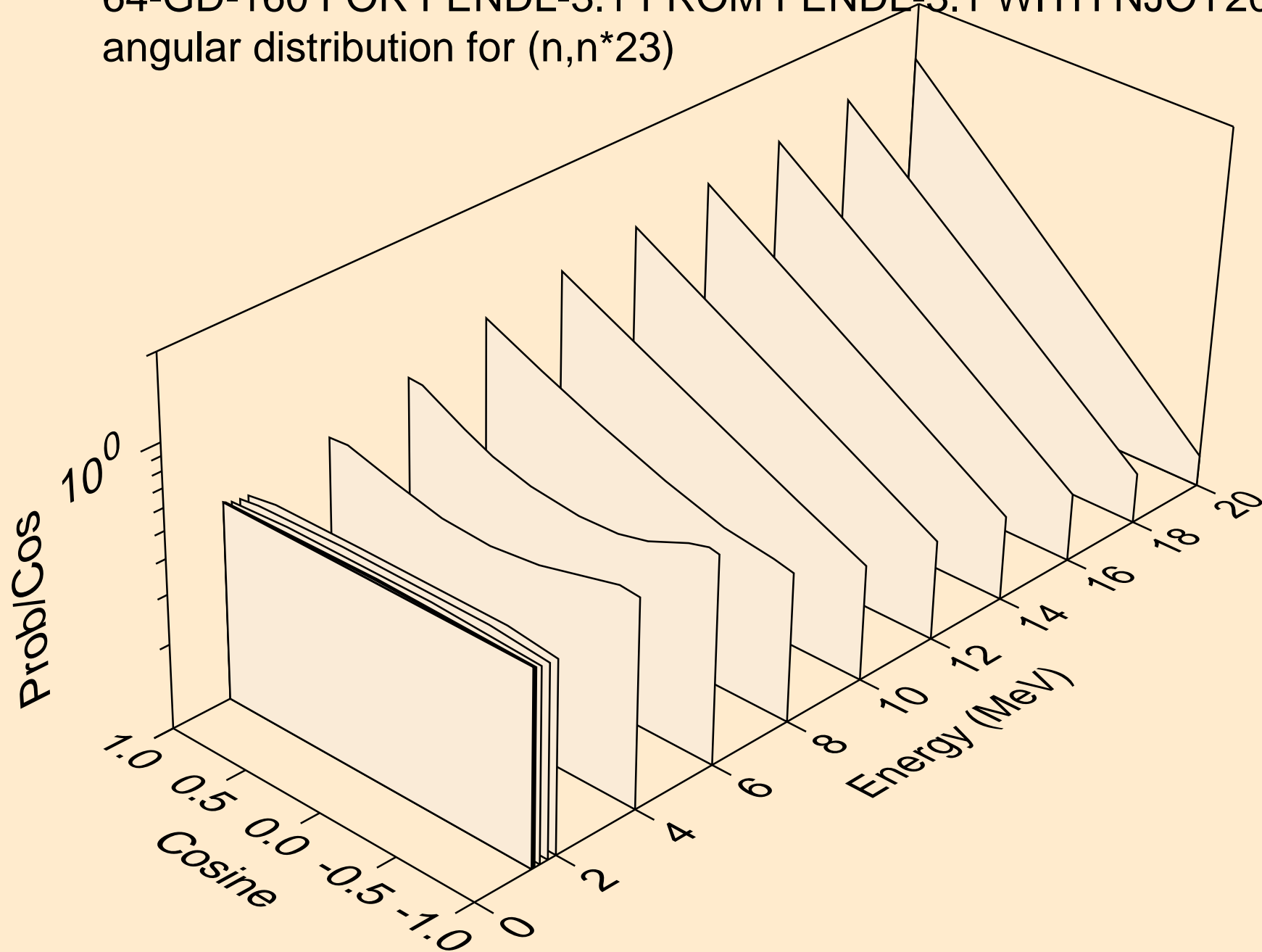

64-GD-160 FOR FENDL-3.1 FROM FENDL-3.1 WITH NJOY2012.50  
angular distribution for (n,n\*24)

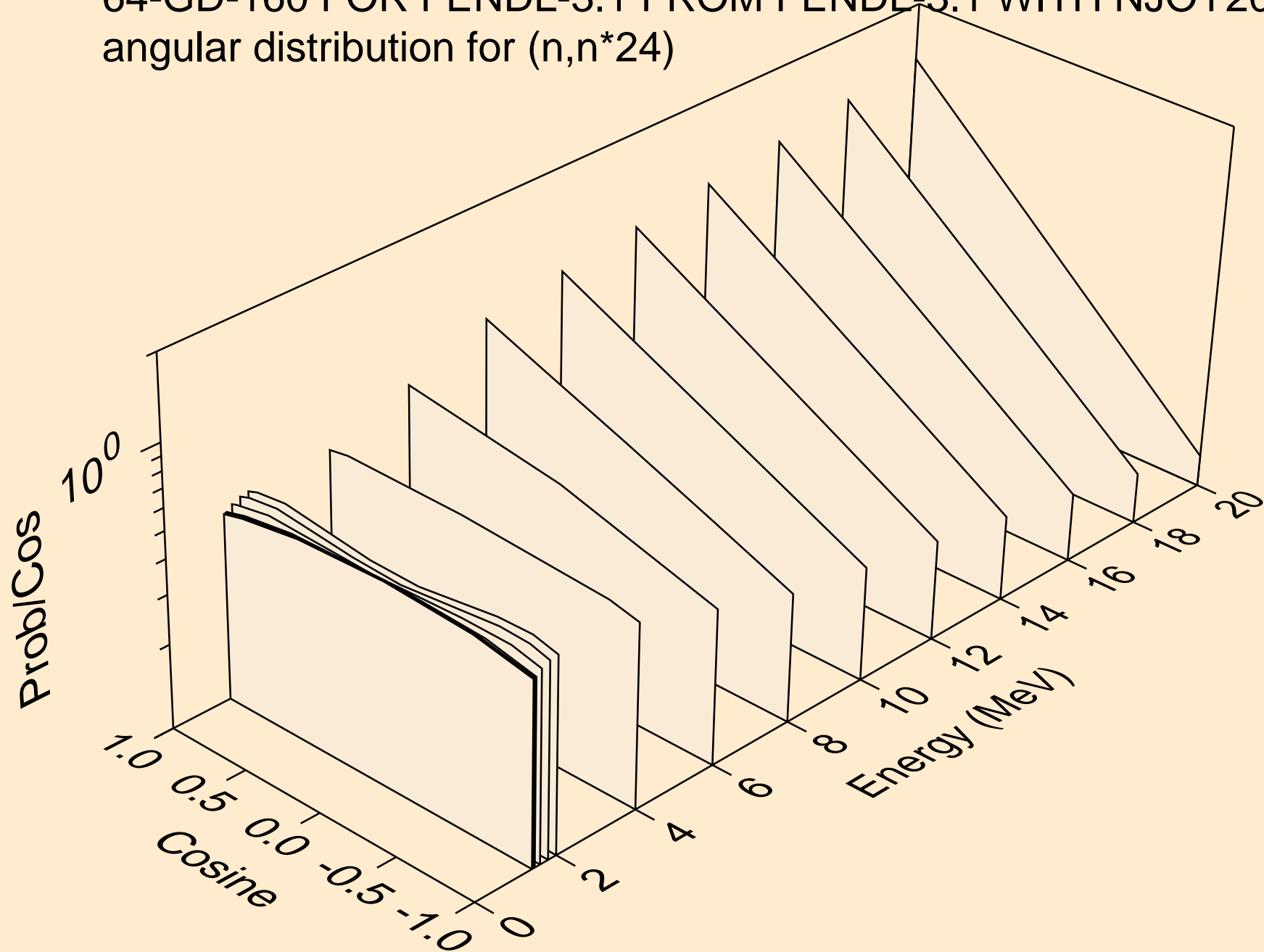

64-GD-160 FOR FENDL-3.1 FROM FENDL-3.1 WITH NJOY2012.50  
angular distribution for (n,n\*25)

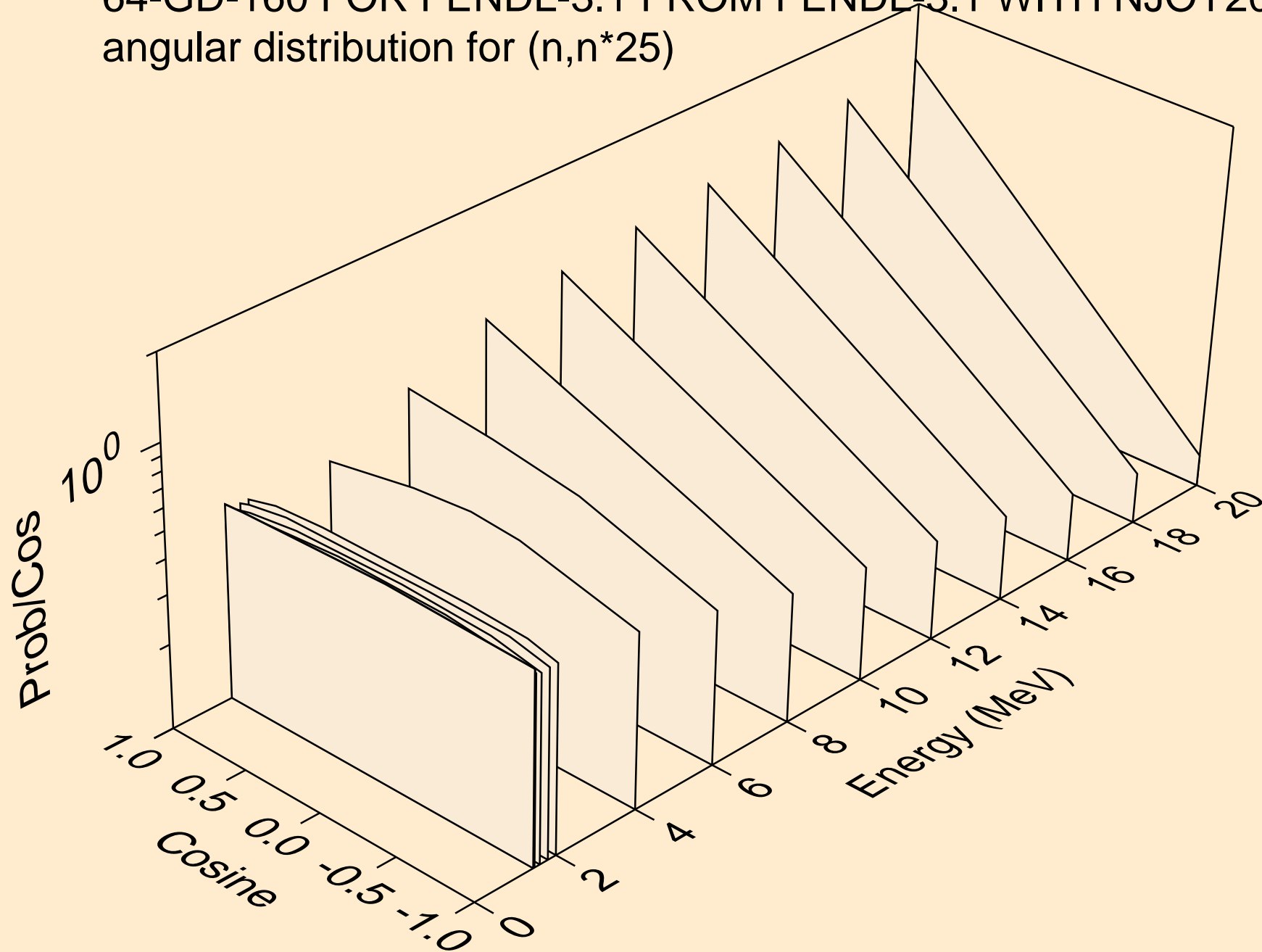

64-GD-160 FOR FENDL-3.1 FROM FENDL-3.1 WITH NJOY2012.50  
angular distribution for (n,n\*26)

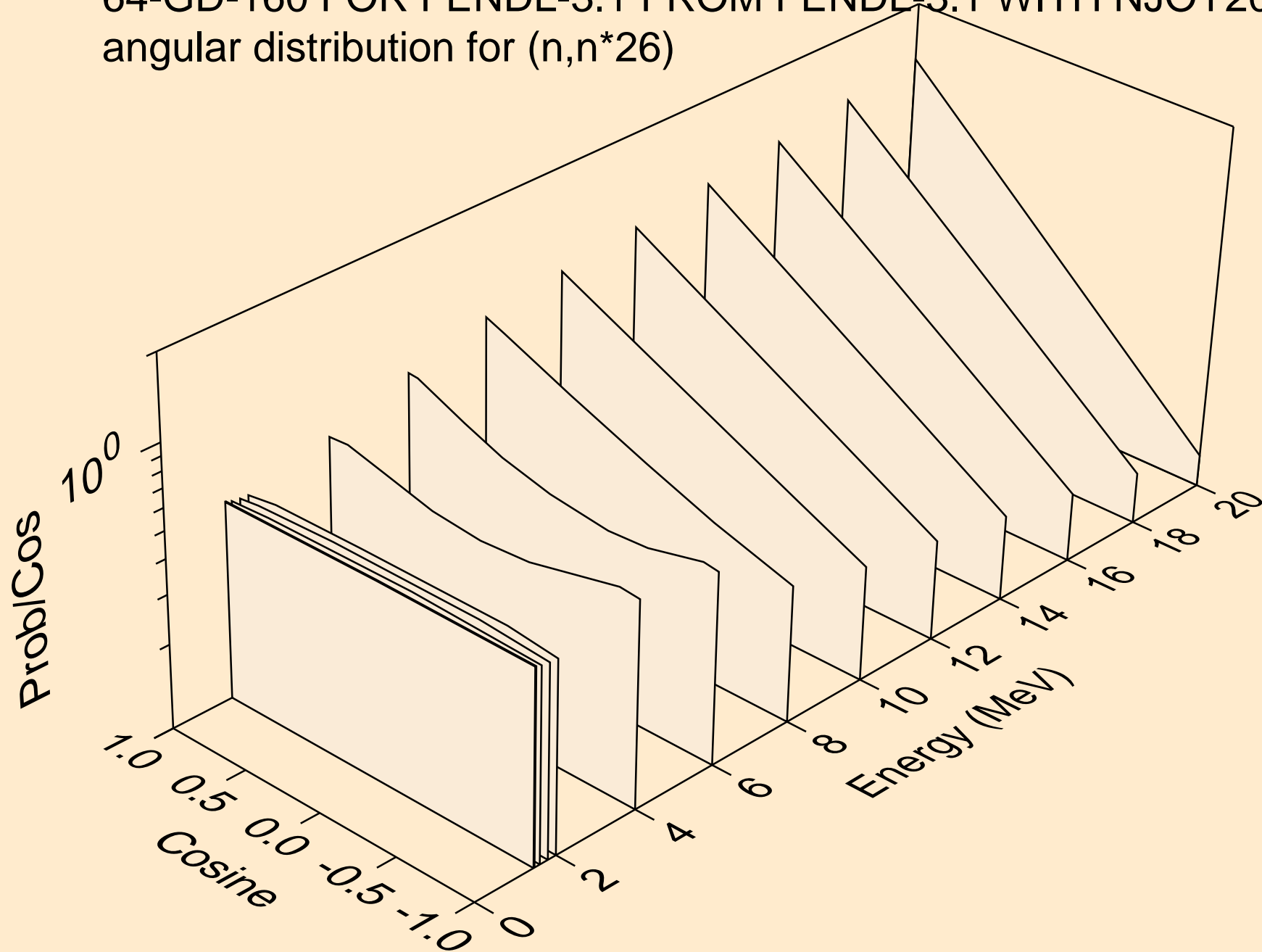

64-GD-160 FOR FENDL-3.1 FROM FENDL-3.1 WITH NJOY2012.50  
angular distribution for (n,n\*27)

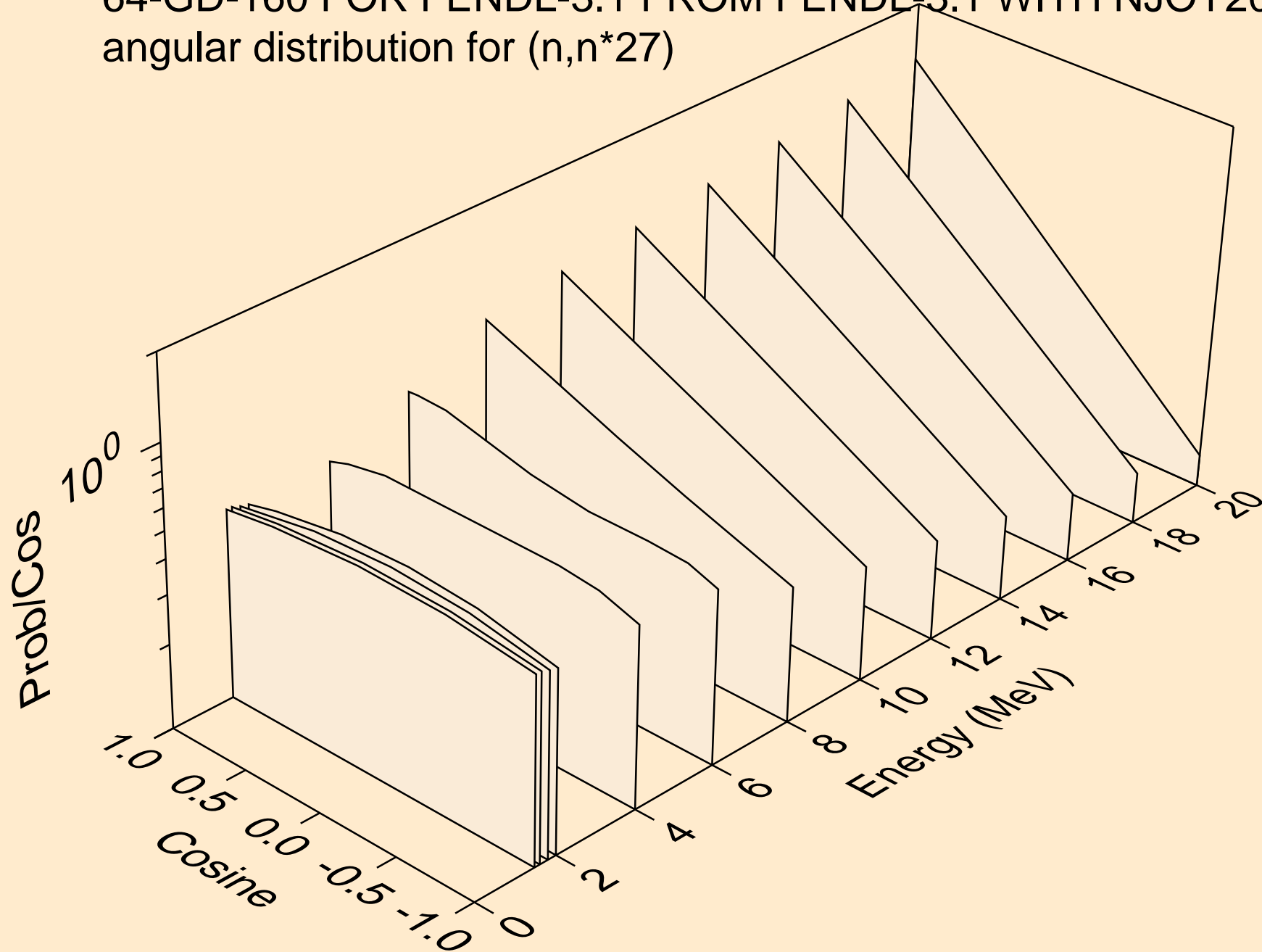



64-GD-160 FOR FENDL-3.1 FROM FENDL-3.1 WITH NJOY2012.50  
Neutron emission for (n,x)

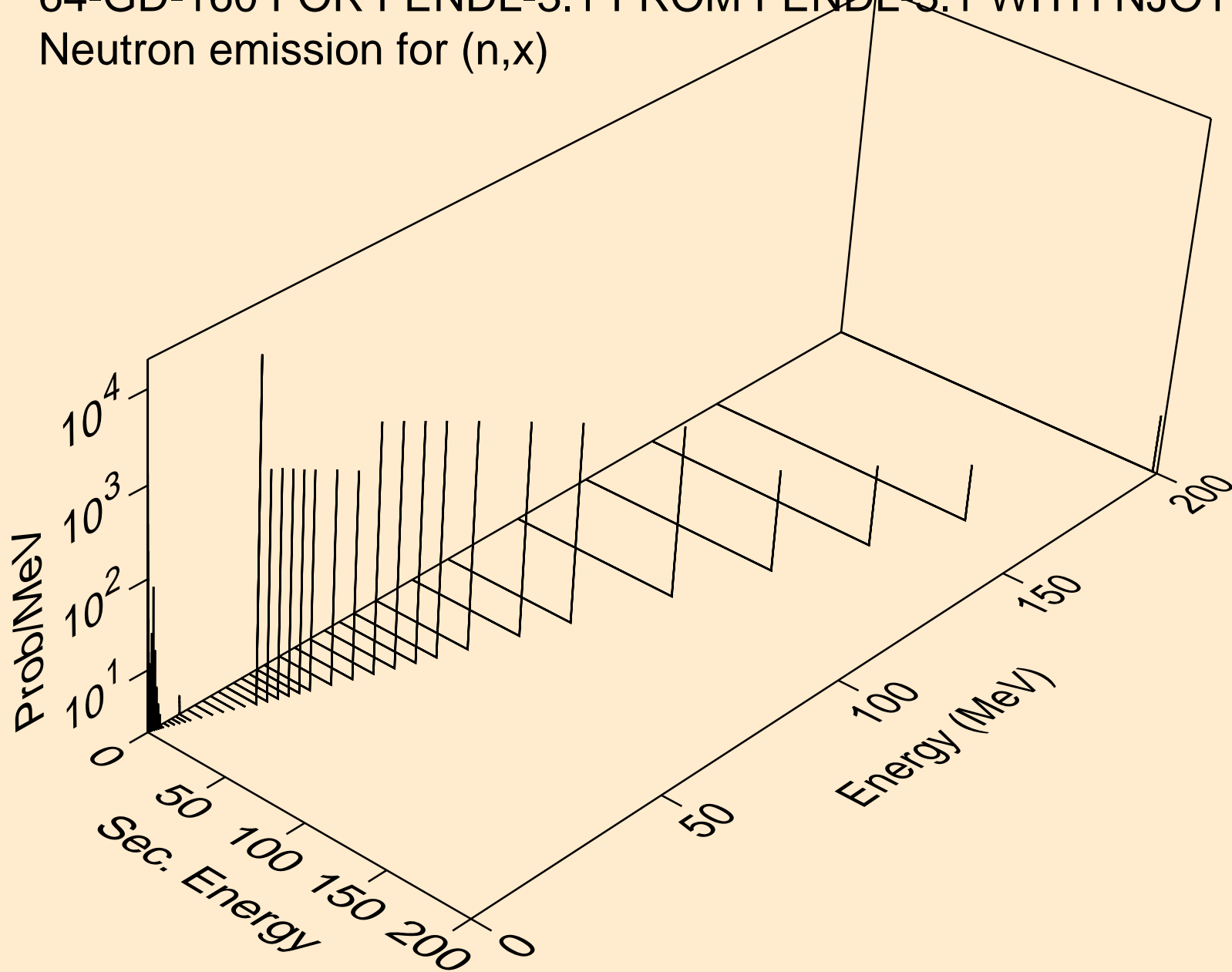

64-GD-160 FOR FENDL-3.1 FROM FENDL-3.1 WITH NJOY2012.50  
Neutron emission for (n,2n)

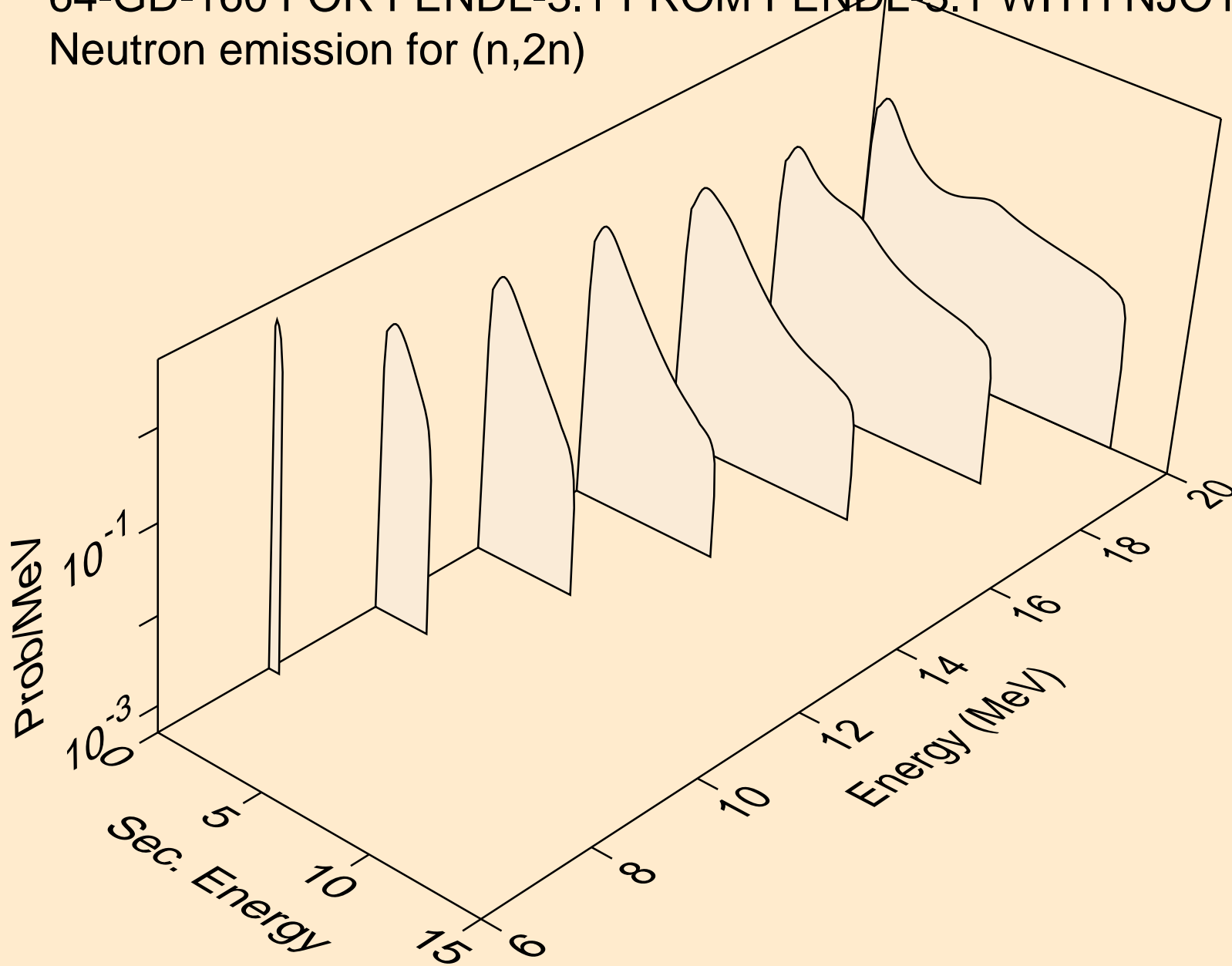

64-GD-160 FOR FENDL-3.1 FROM FENDL-3.1 WITH NJOY2012.50  
Neutron emission for (n,3n)

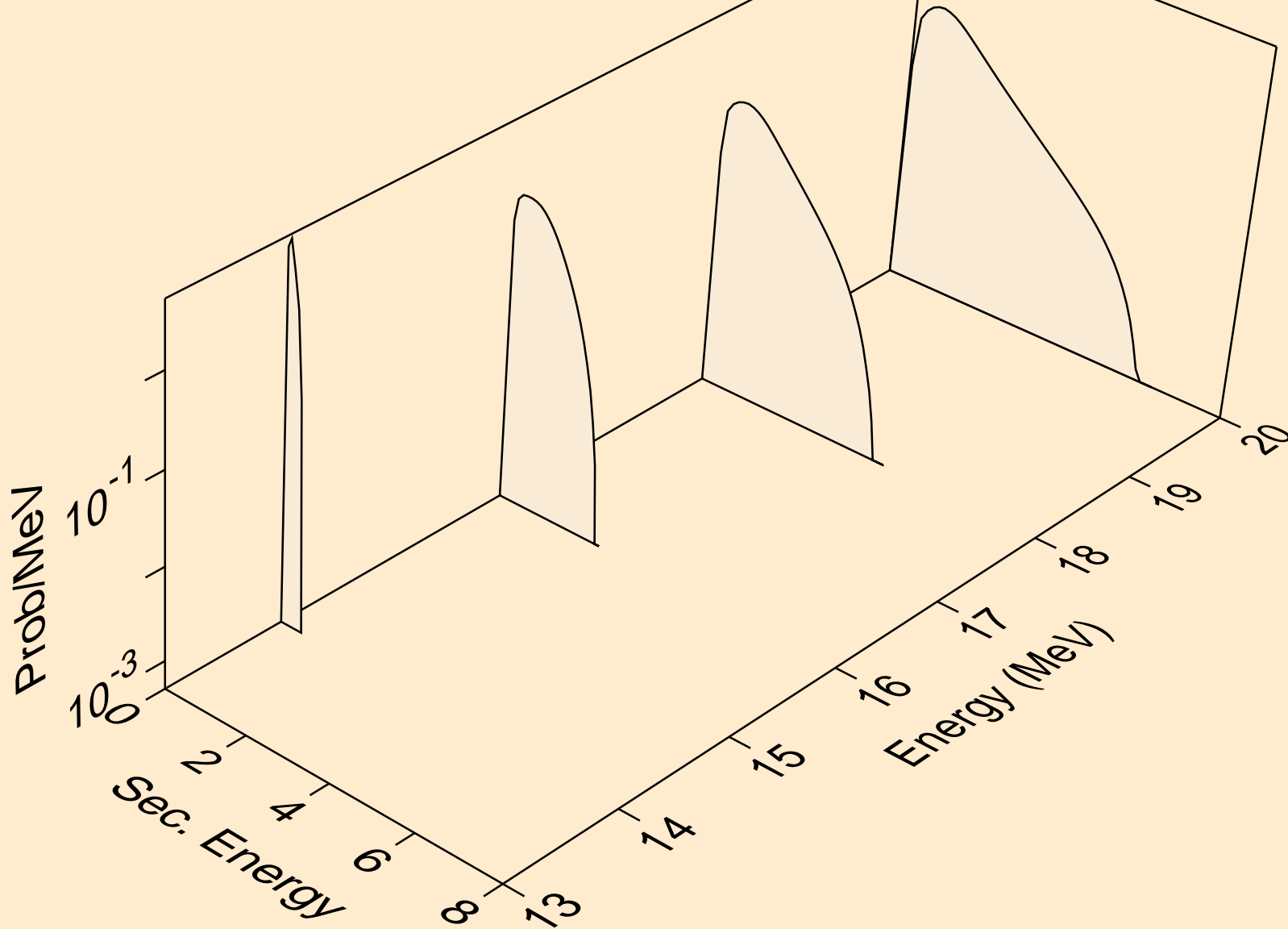

64-GD-160 FOR FENDL-3.1 FROM FENDL-3.1 WITH NJOY2012.50  
Neutron emission for (n,n\*)a

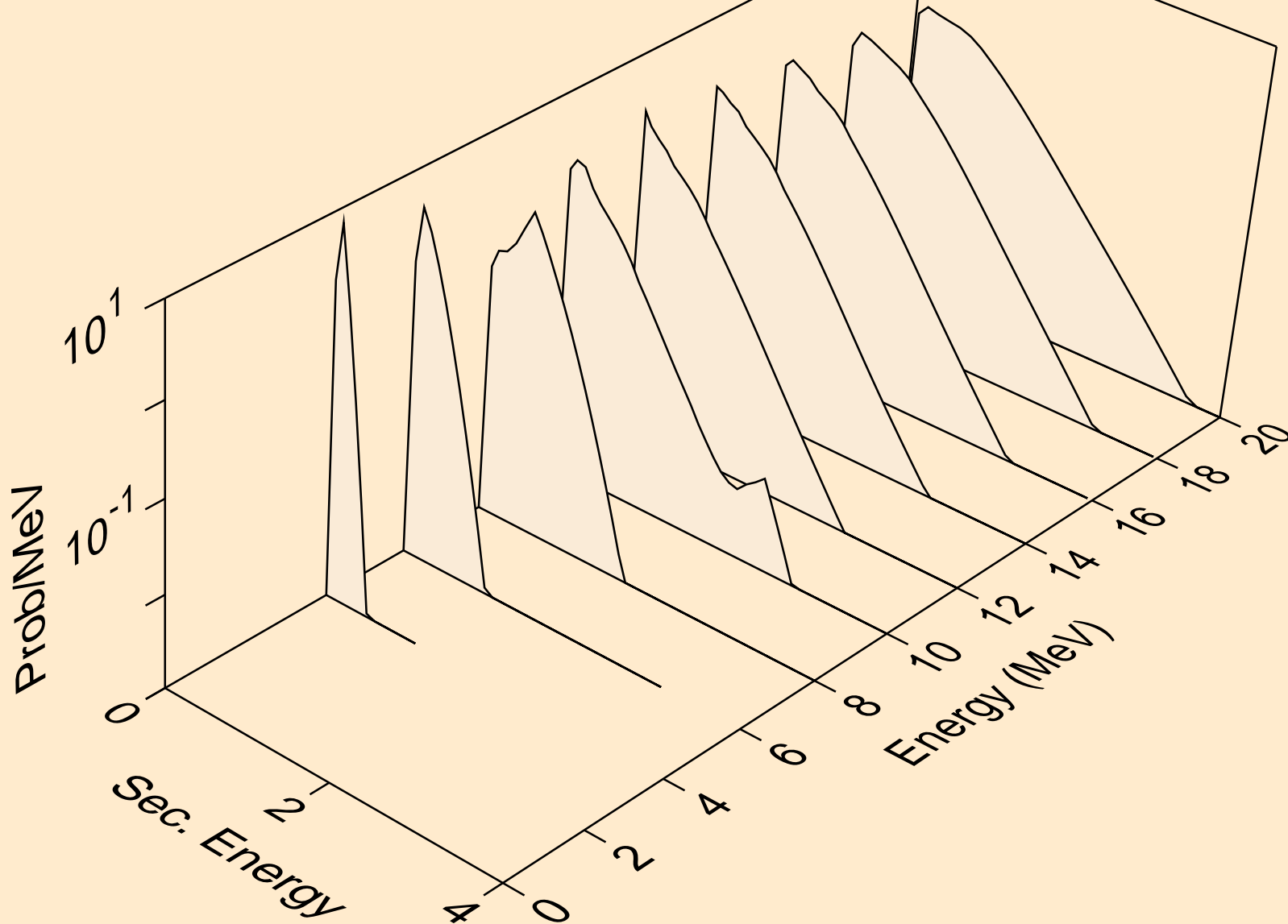

64-GD-160 FOR FENDL-3.1 FROM FENDL-3.1 WITH NJOY2012.50  
Neutron emission for (n,2n)a

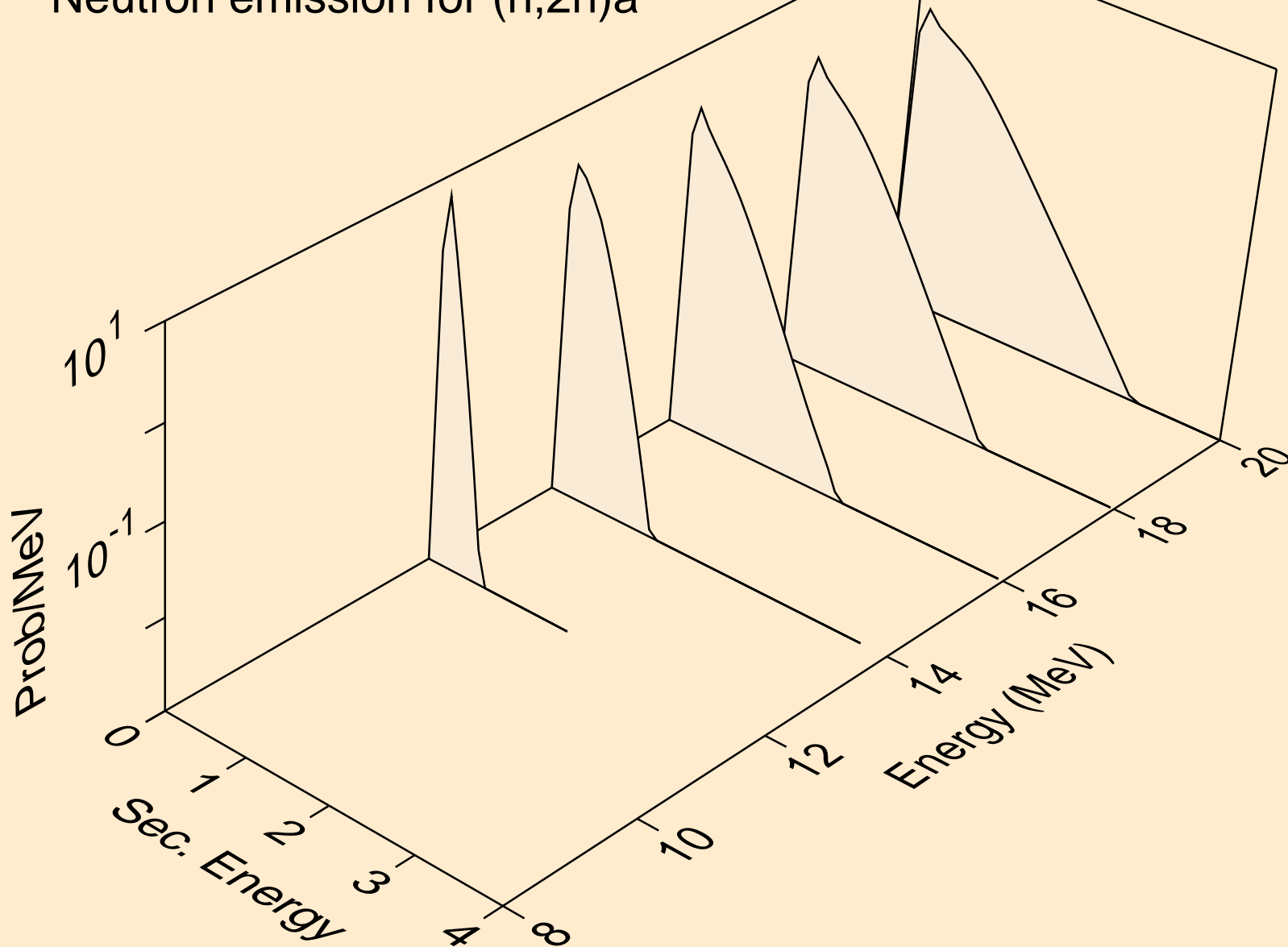

64-GD-160 FOR FENDL-3.1 FROM FENDL-3.1 WITH NJOY2012.50  
Neutron emission for (n,n\*)p

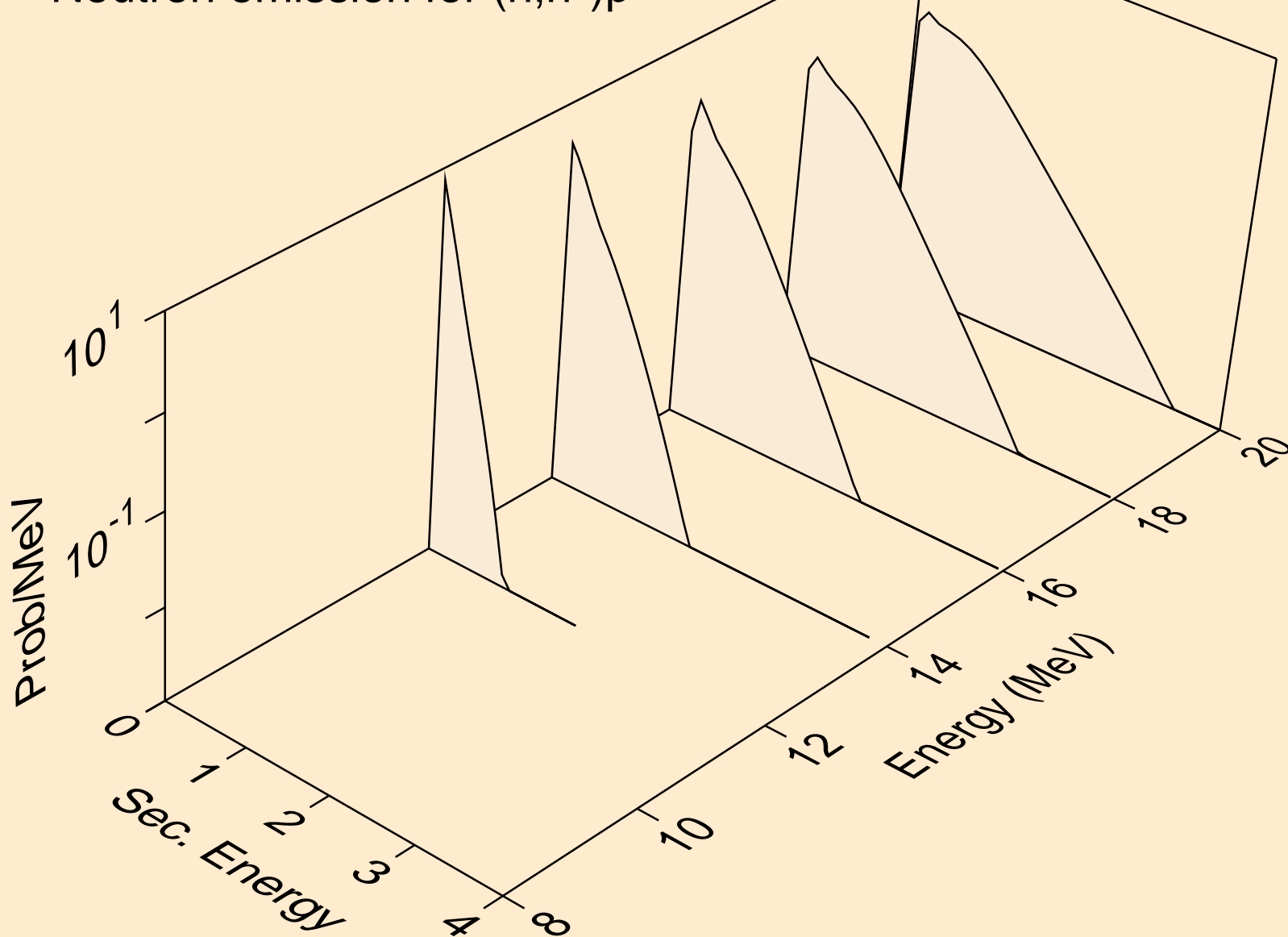

64-GD-160 FOR FENDL-3.1 FROM FENDL-3.1 WITH NJOY2012.50  
Neutron emission for (n,n\*)d

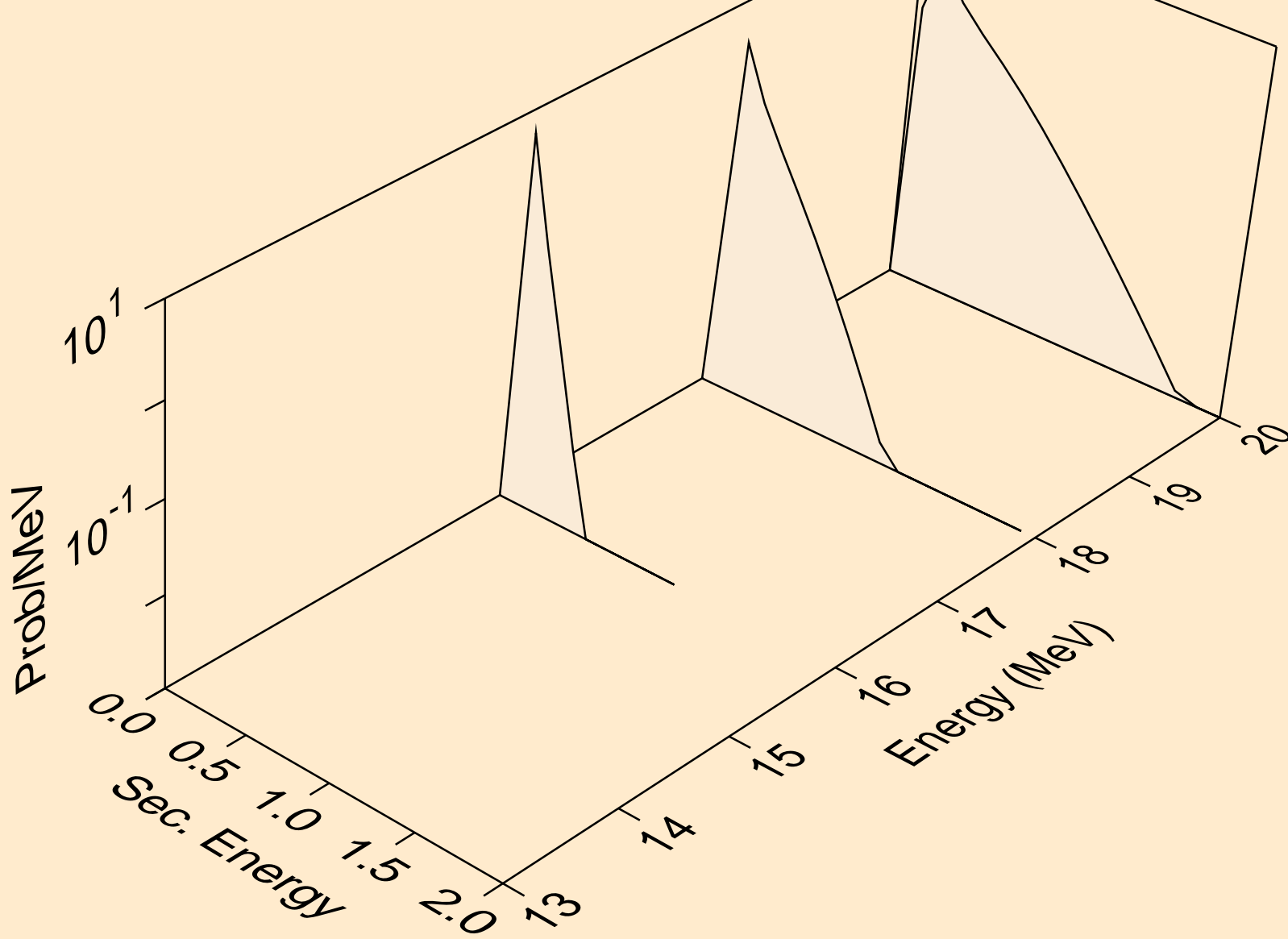

64-GD-160 FOR FENDL-3.1 FROM FENDL-3.1 WITH NJOY2012.50  
Neutron emission for (n,n\*)t

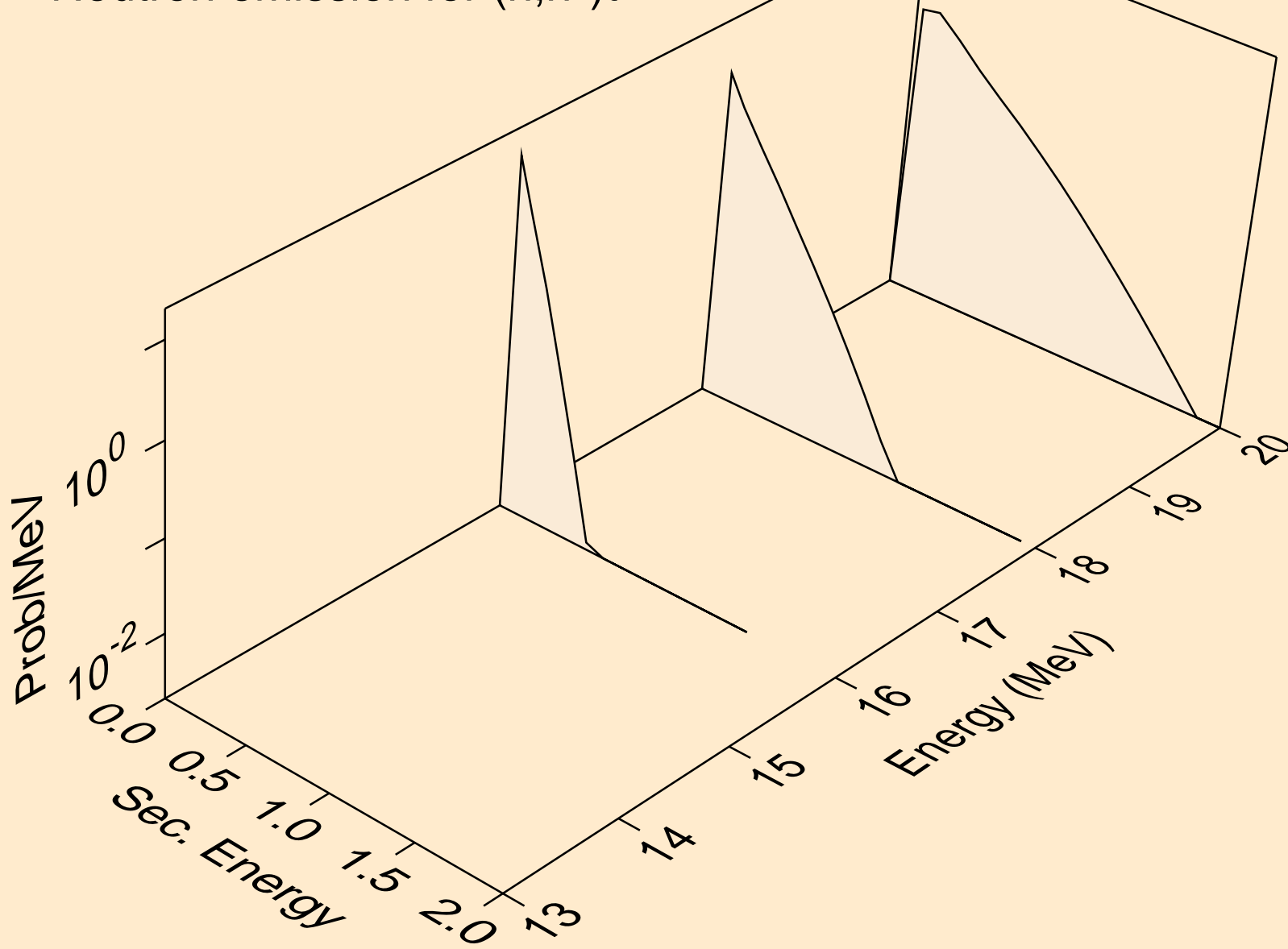



64-GD-160 FOR FENDL-3.1 FROM FENDL-3.1 WITH NJOY2012.50  
Neutron emission for (n,n\*c)

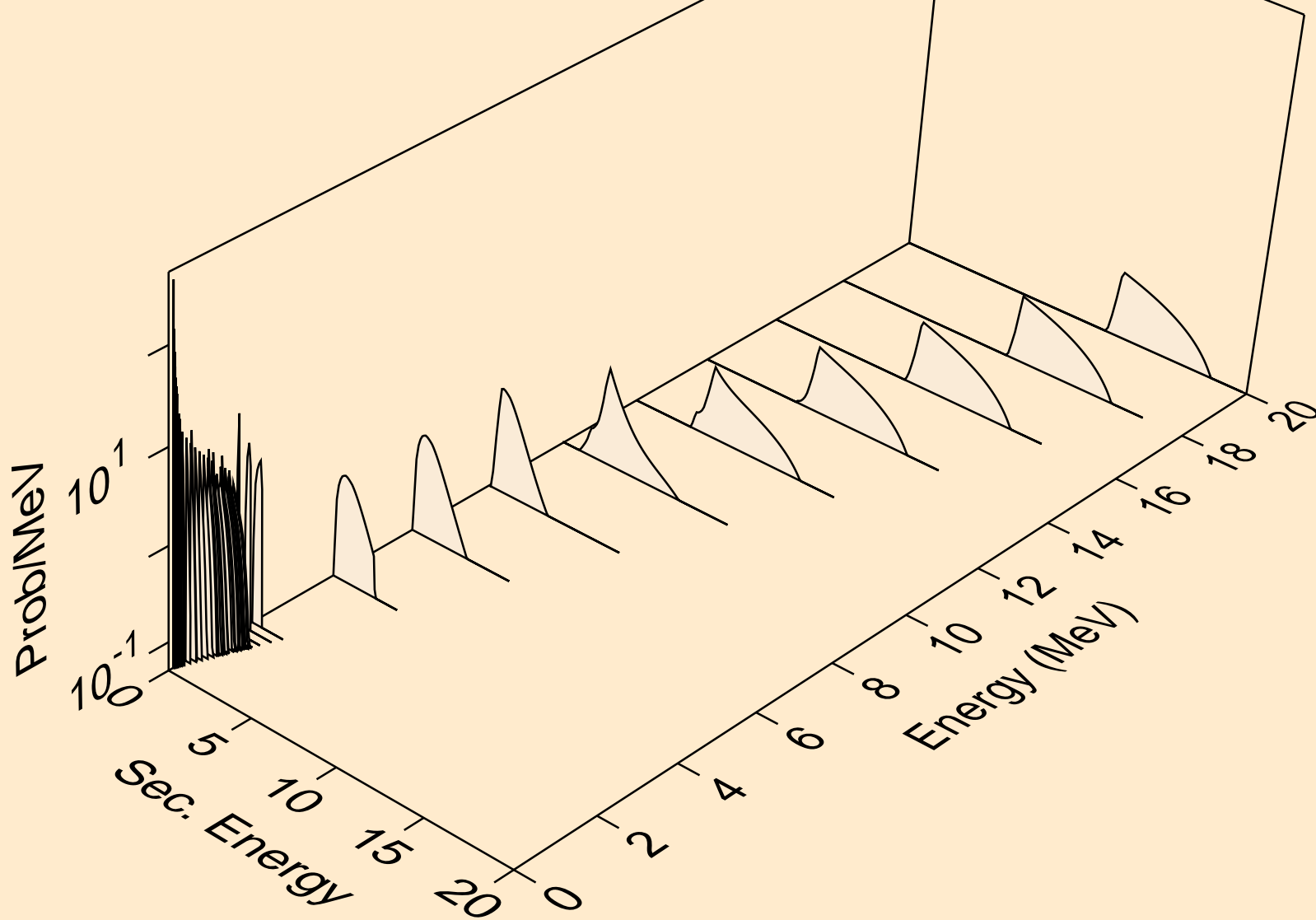

64-GD-160 FOR FENDL-3.1 FROM FENDL-3.1 WITH NJOY2012.50  
Photon emission for (n,x)

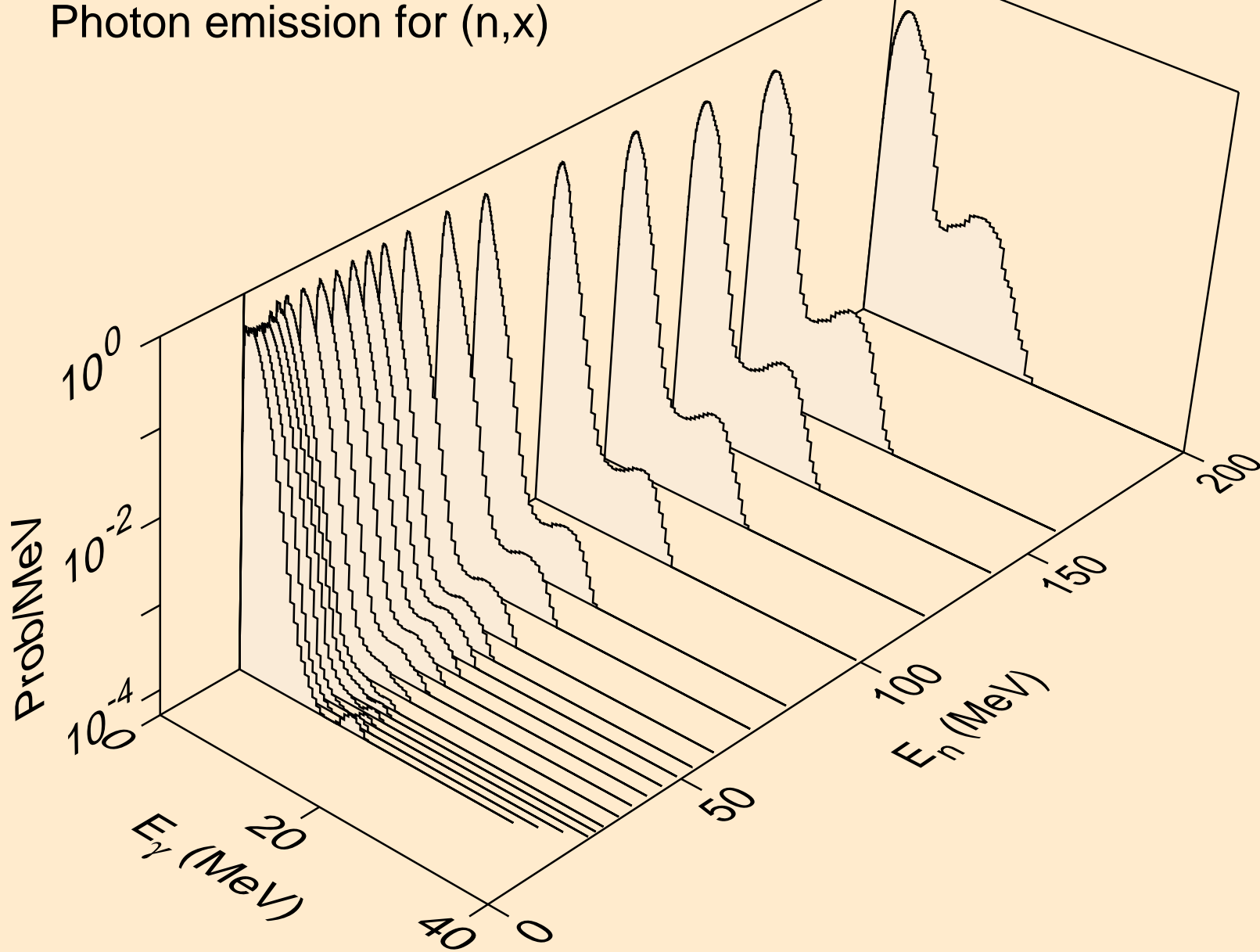

64-GD-160 FOR FENDL-3.1 FROM FENDL-3.1 WITH NJOY2012.50  
Photon emission for (n,2n)

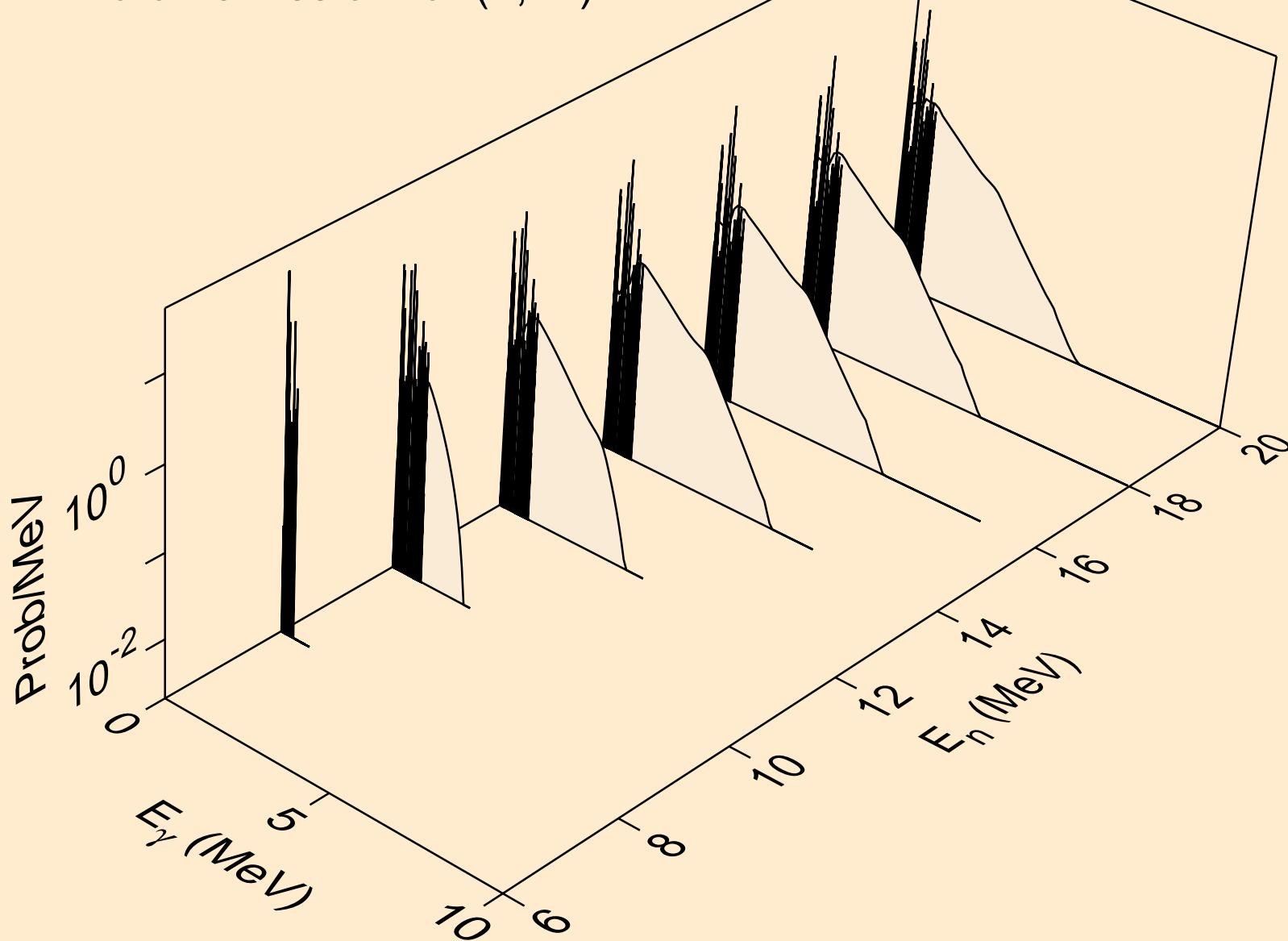

64-GD-160 FOR FENDL-3.1 FROM FENDL-3.1 WITH NJOY2012.50  
Photon emission for (n,3n)

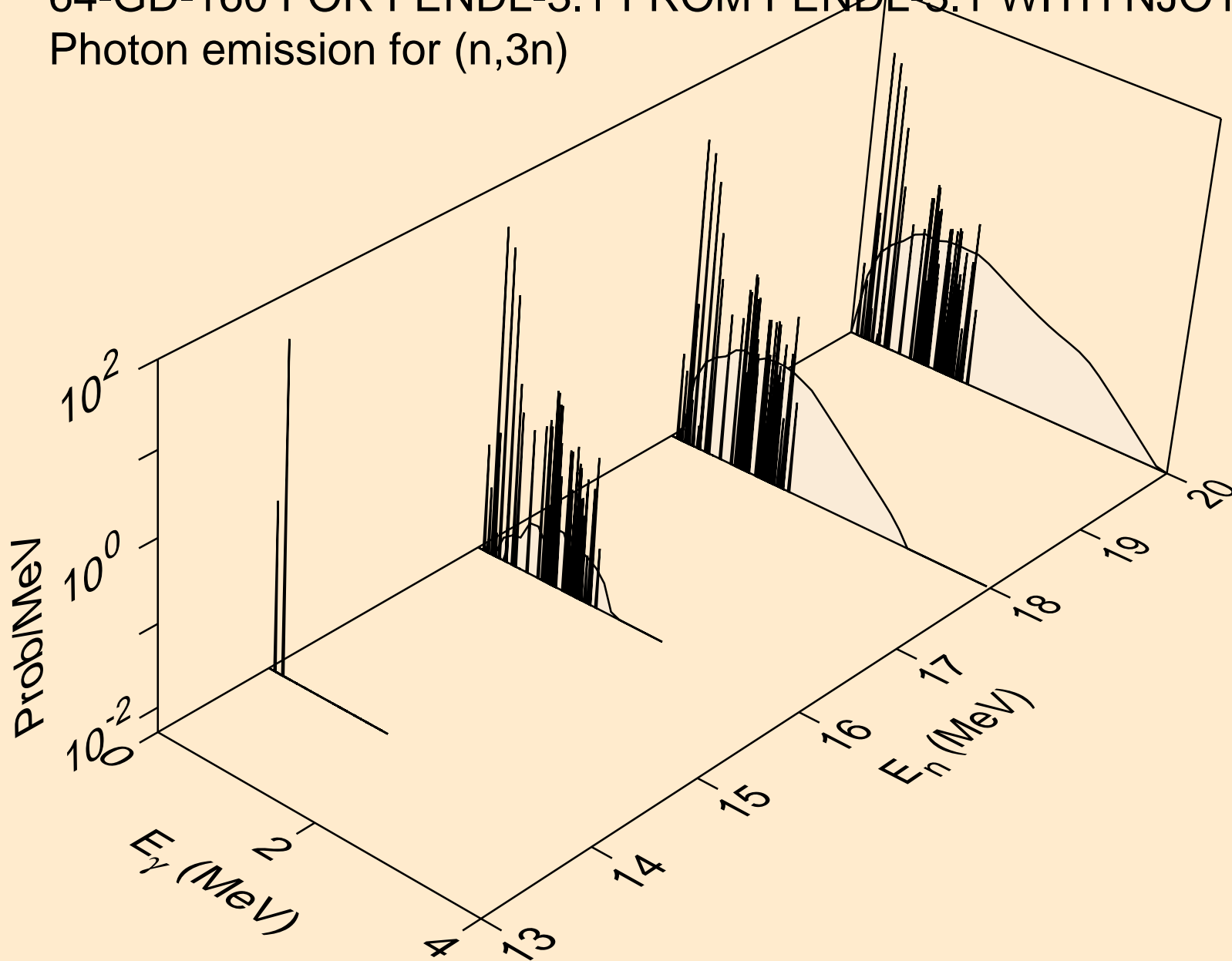

64-GD-160 FOR FENDL-3.1 FROM FENDL-3.1 WITH NJOY2012.50  
Photon emission for (n,n\*)a

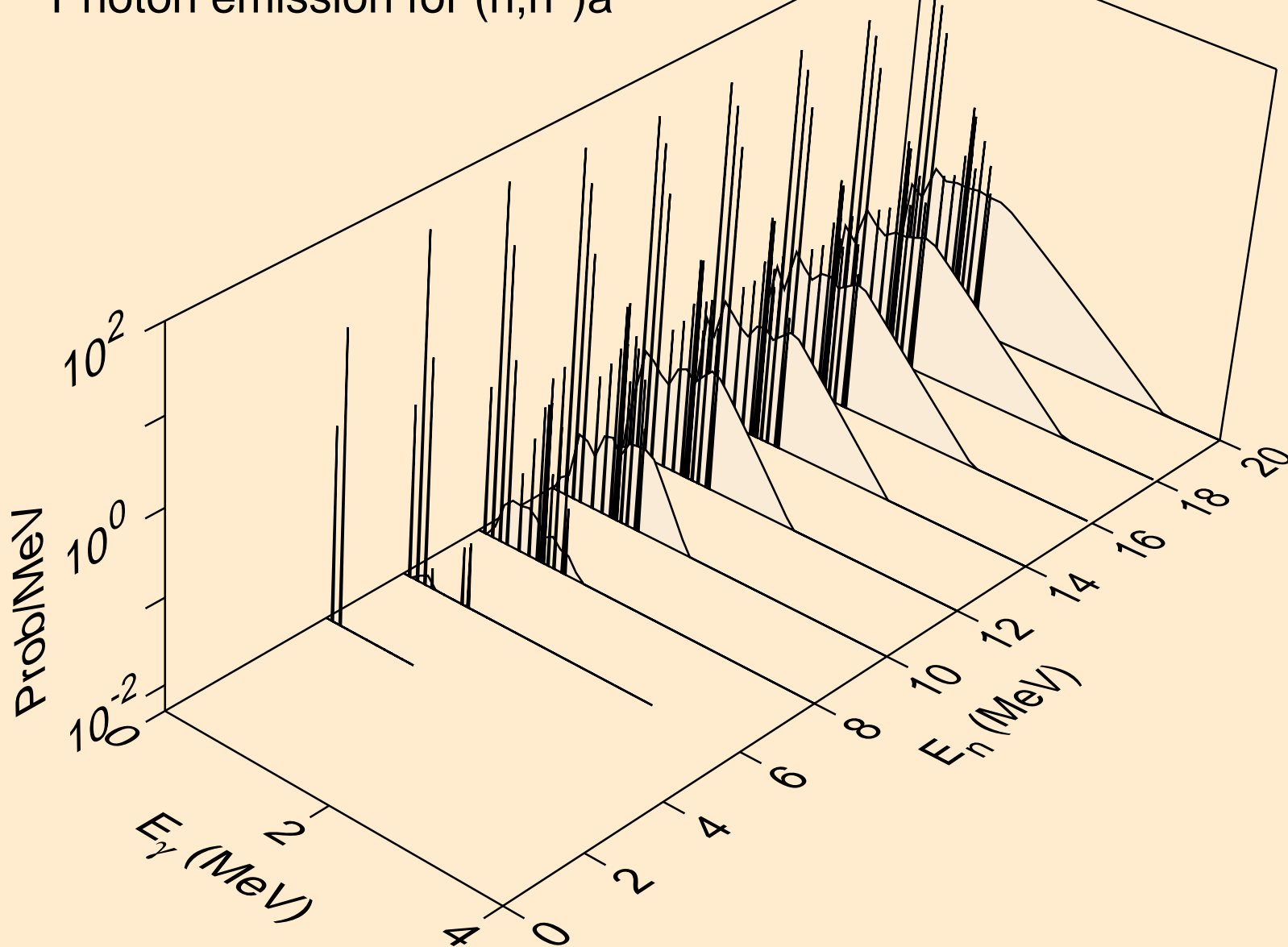

64-GD-160 FOR FENDL-3.1 FROM FENDL-3.1 WITH NJOY2012.50  
Photon emission for (n,2n)a

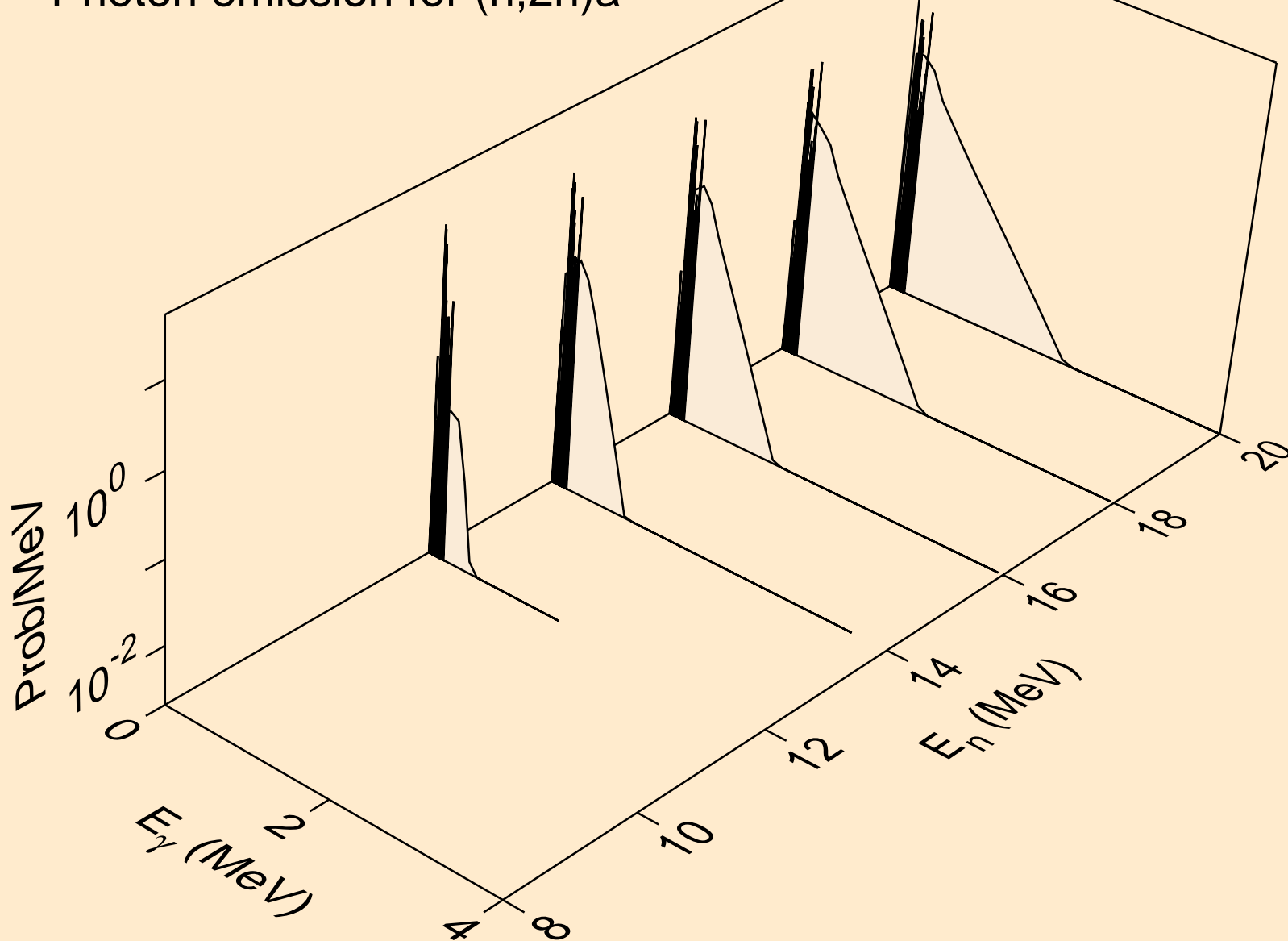

64-GD-160 FOR FENDL-3.1 FROM FENDL-3.1 WITH NJOY2012.50  
Photon emission for (n,n\*)p

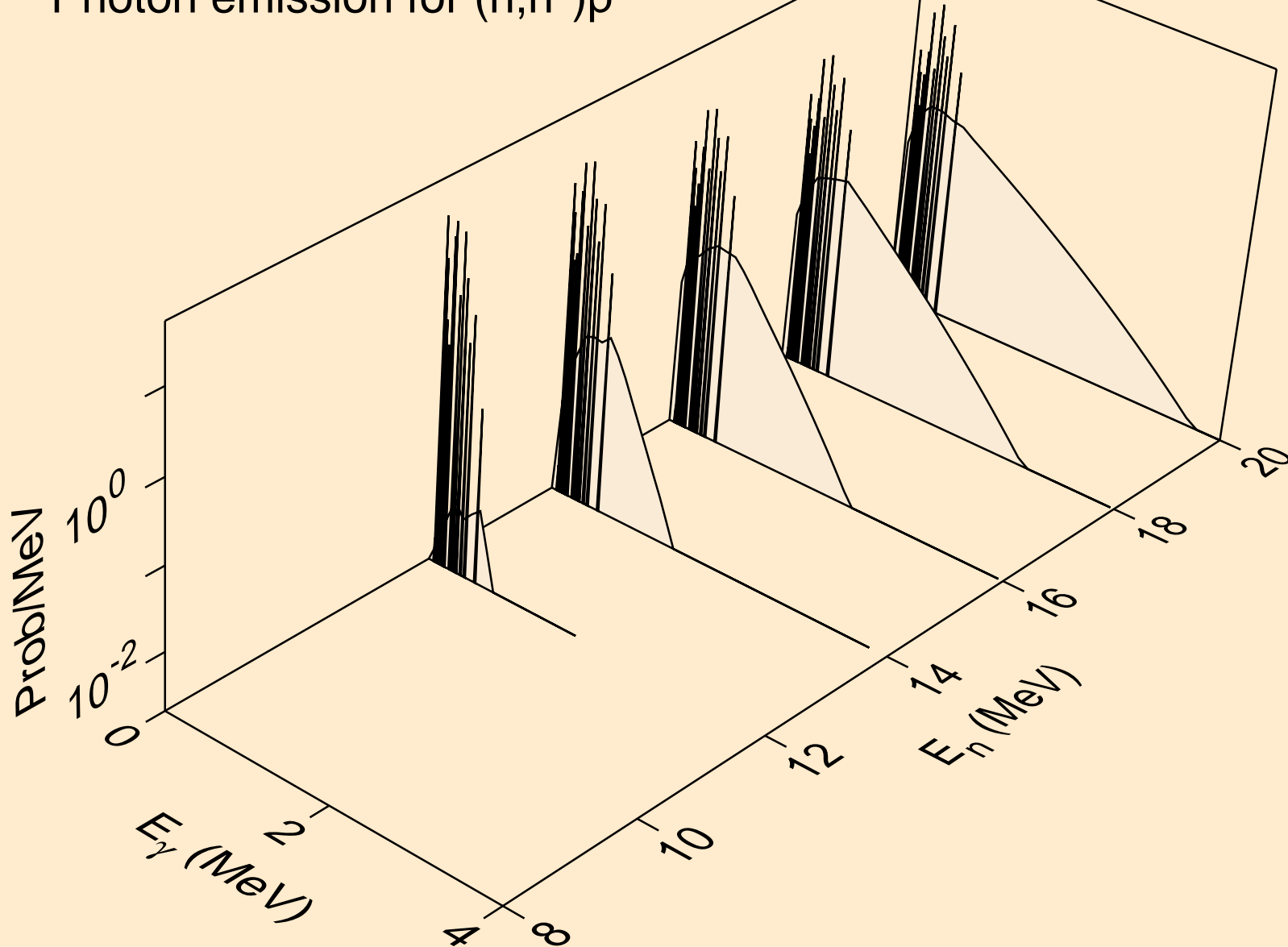

64-GD-160 FOR FENDL-3.1 FROM FENDL-3.1 WITH NJOY2012.50  
Photon emission for (n,n\*)d

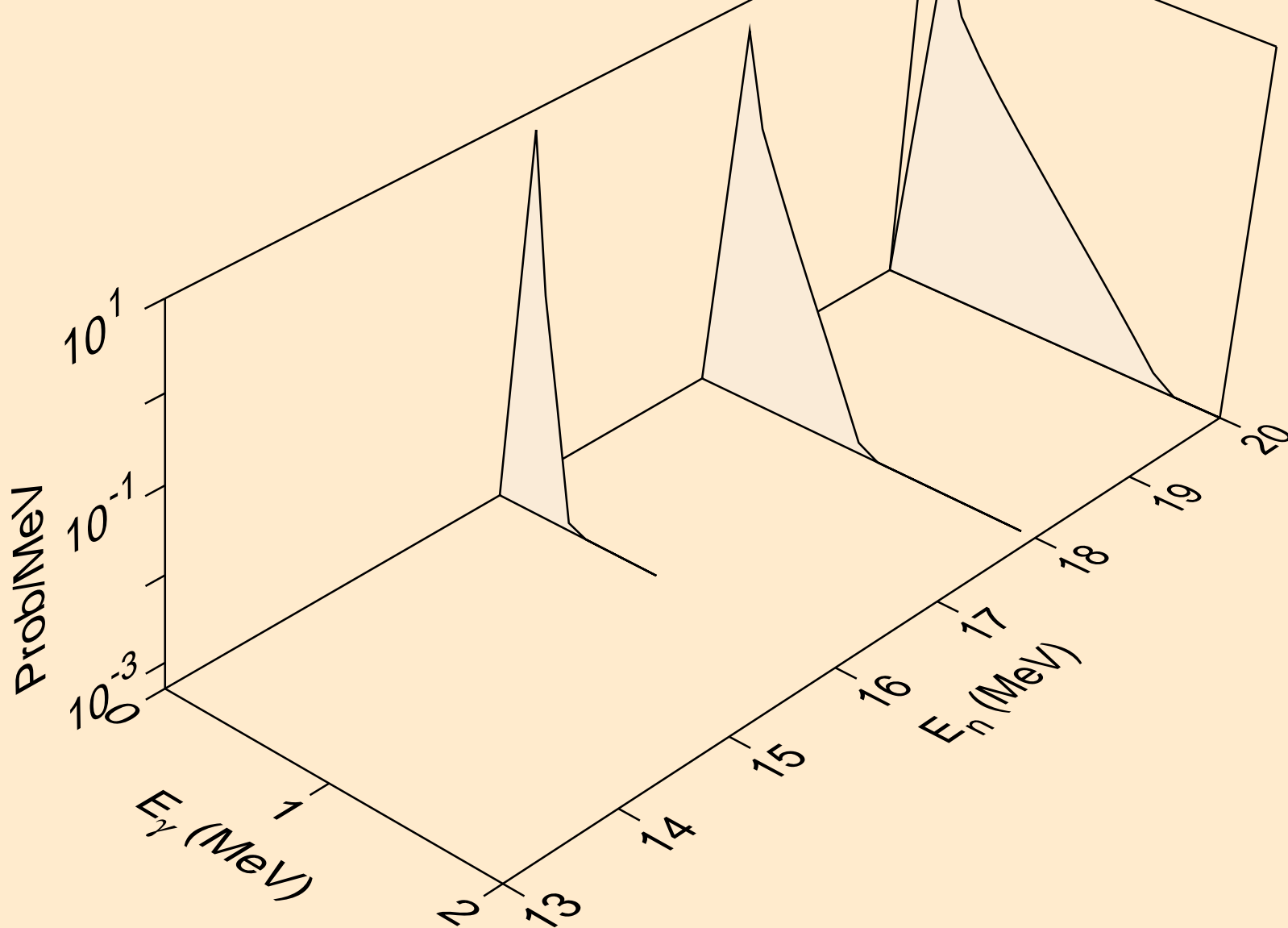



64-GD-160 FOR FENDL-3.1 FROM FENDL-3.1 WITH NJOY2012.50  
Photon emission for (n,n\*)t

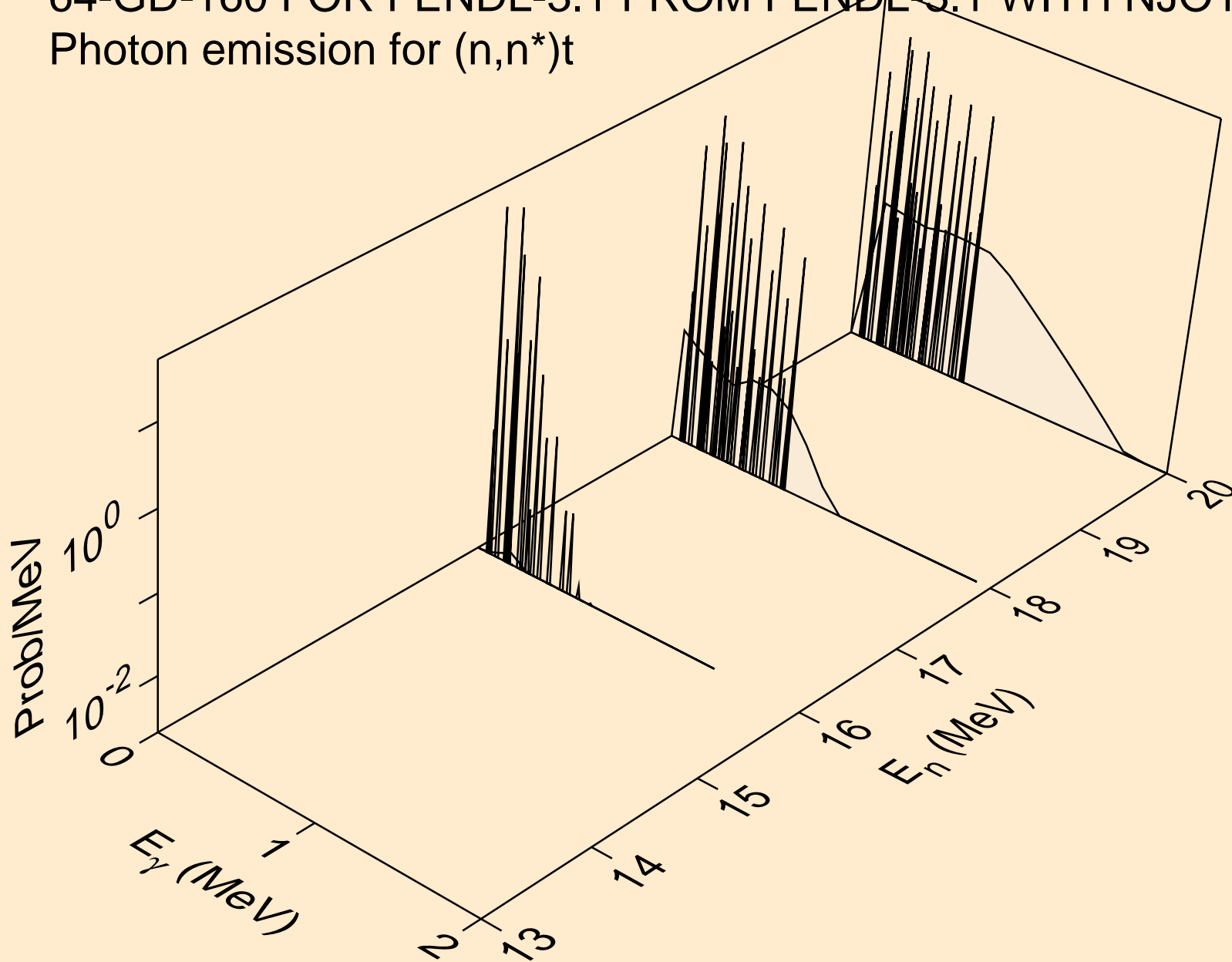

64-GD-160 FOR FENDL-3.1 FROM FENDL-3.1 WITH NJOY2012.50  
Photon emission for (n,n\*1)

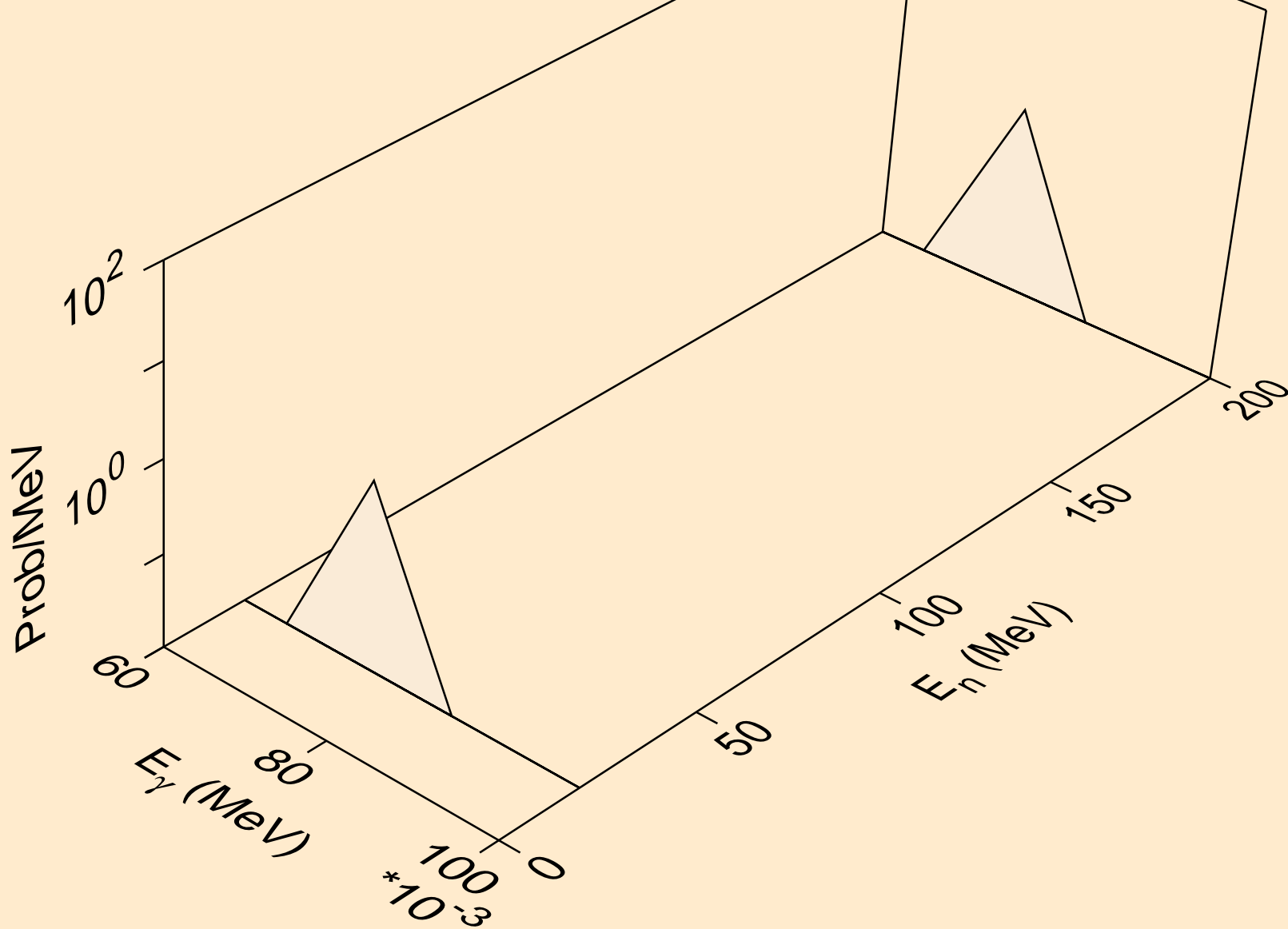

64-GD-160 FOR FENDL-3.1 FROM FENDL-3.1 WITH NJOY2012.50  
Photon emission for (n,n\*2)

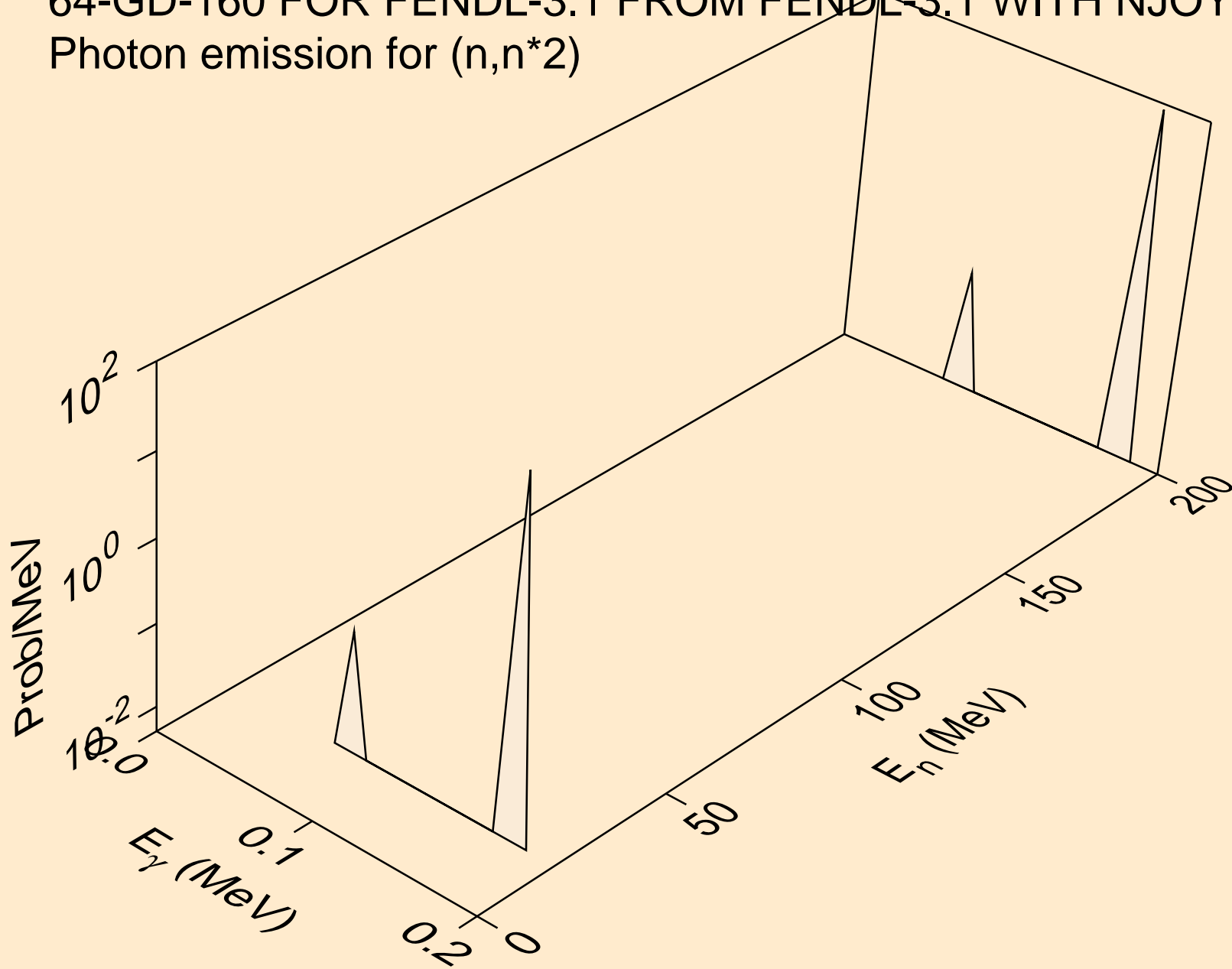

64-GD-160 FOR FENDL-3.1 FROM FENDL-3.1 WITH NJOY2012.50  
Photon emission for (n,n\*3)

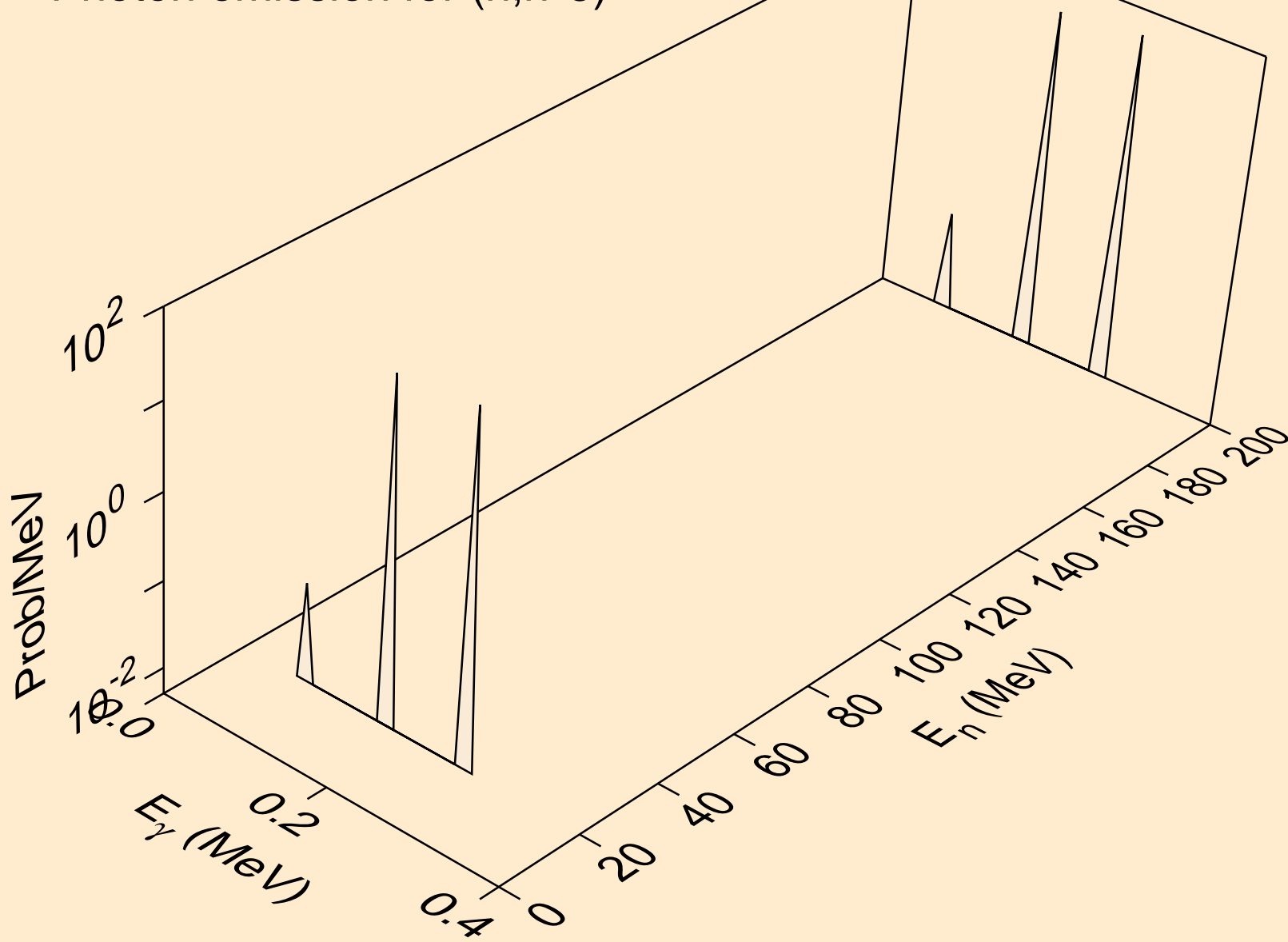

64-GD-160 FOR FENDL-3.1 FROM FENDL-3.1 WITH NJOY2012.50  
Photon emission for (n,n\*4)

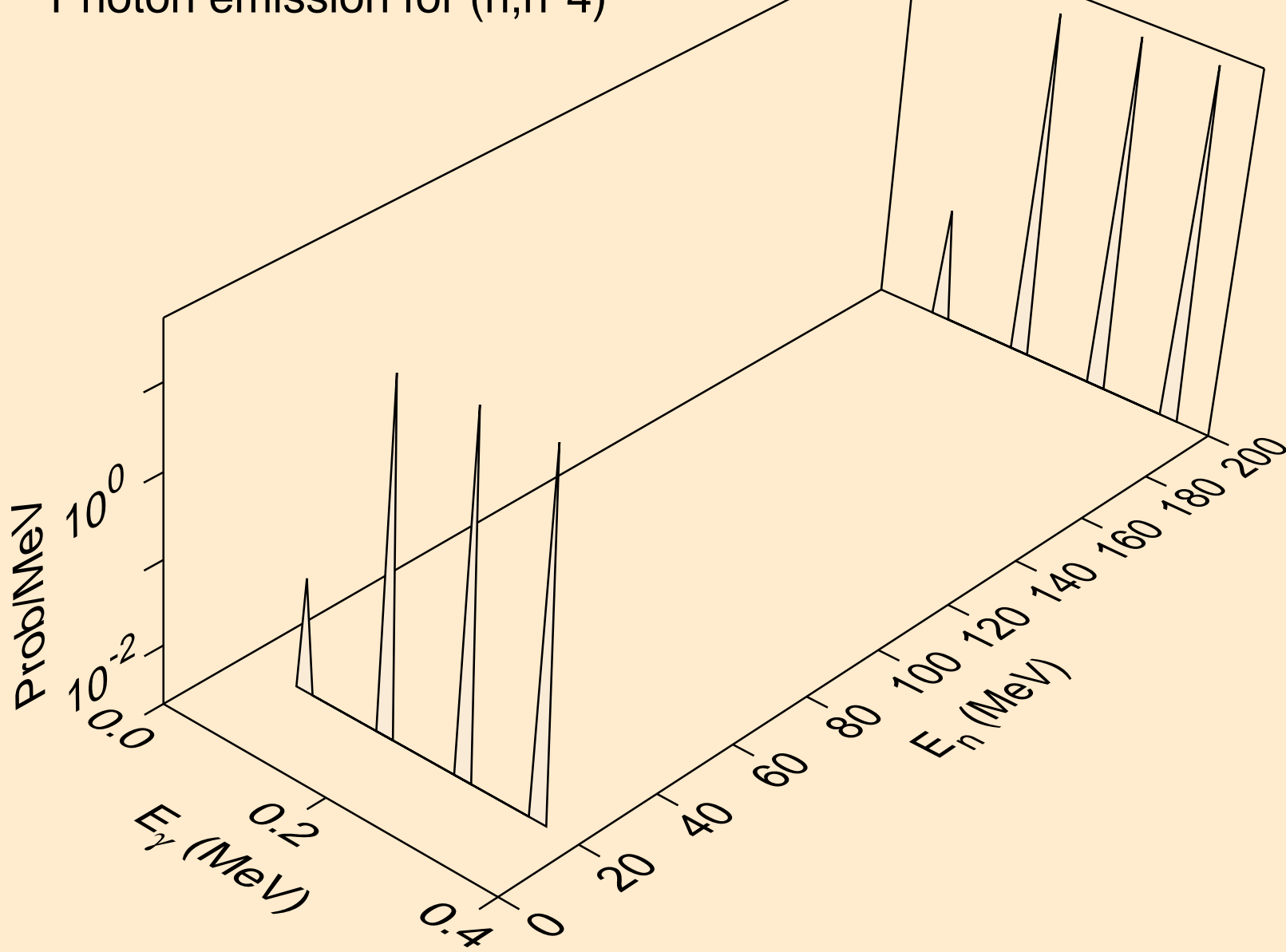

64-GD-160 FOR FENDL-3.1 FROM FENDL-3.1 WITH NJOY2012.50  
Photon emission for (n,n\*5)

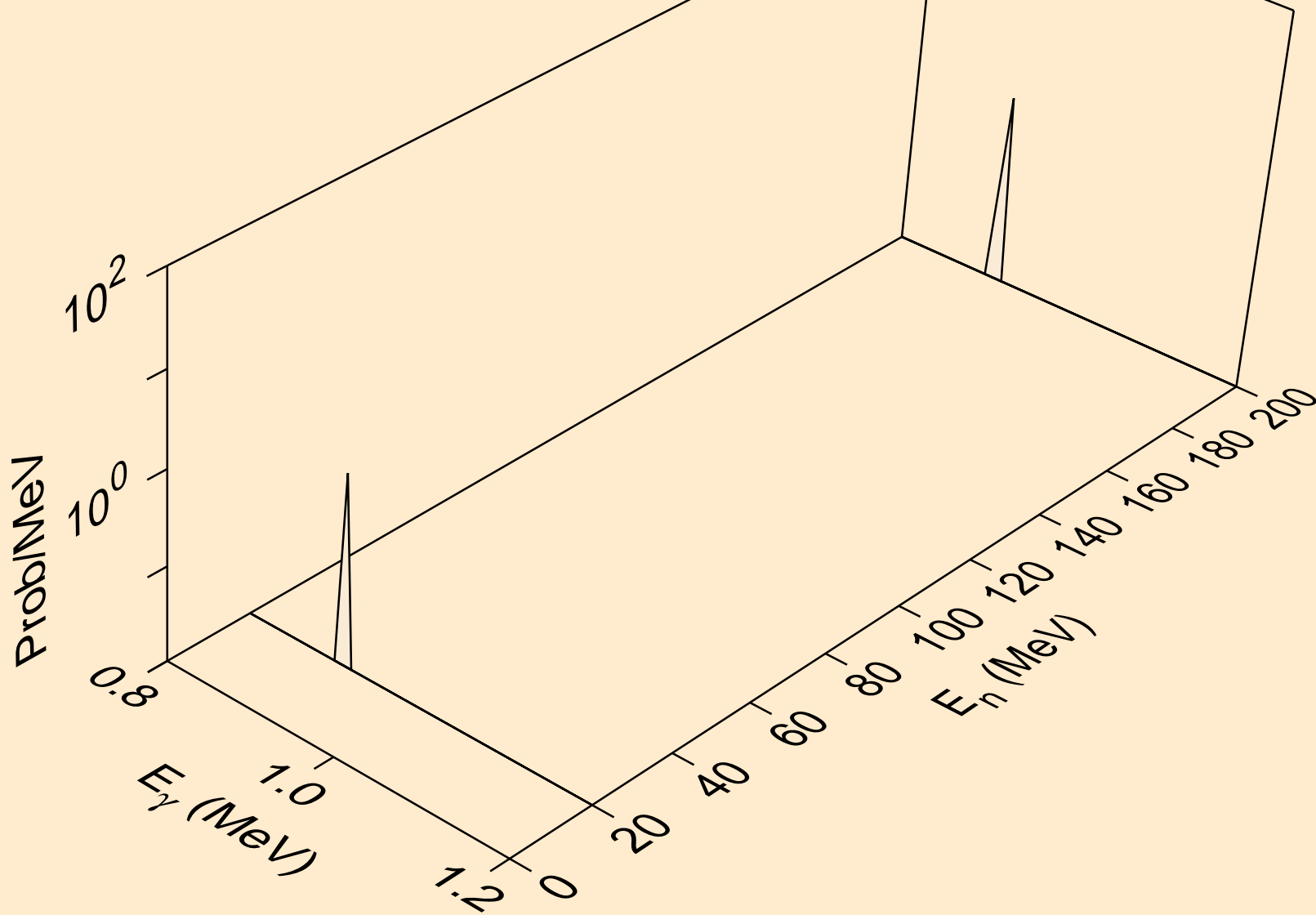

64-GD-160 FOR FENDL-3.1 FROM FENDL-3.1 WITH NJOY2012.50  
Photon emission for (n,n\*6)

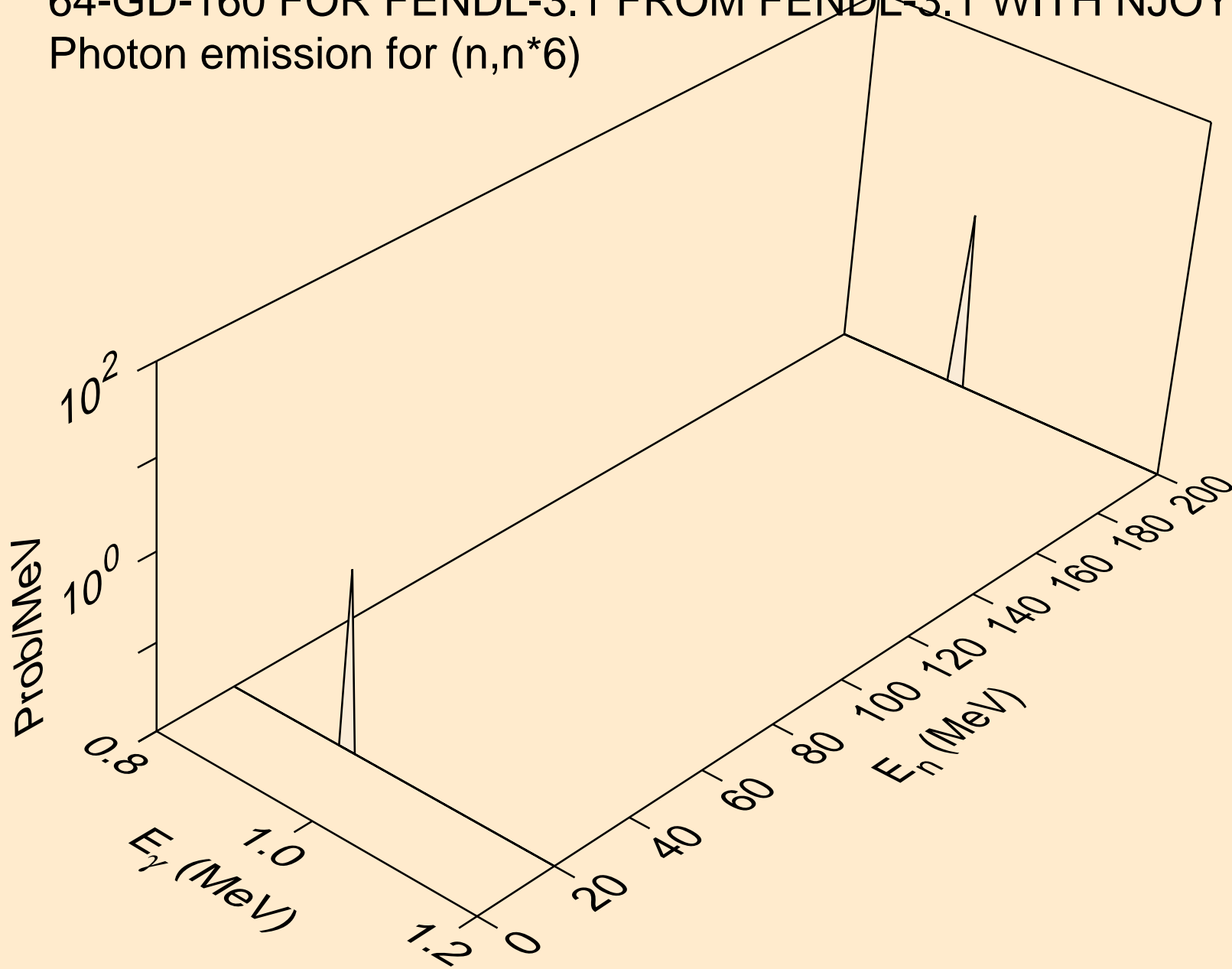

64-GD-160 FOR FENDL-3.1 FROM FENDL-3.1 WITH NJOY2012.50  
Photon emission for (n,n\*7)

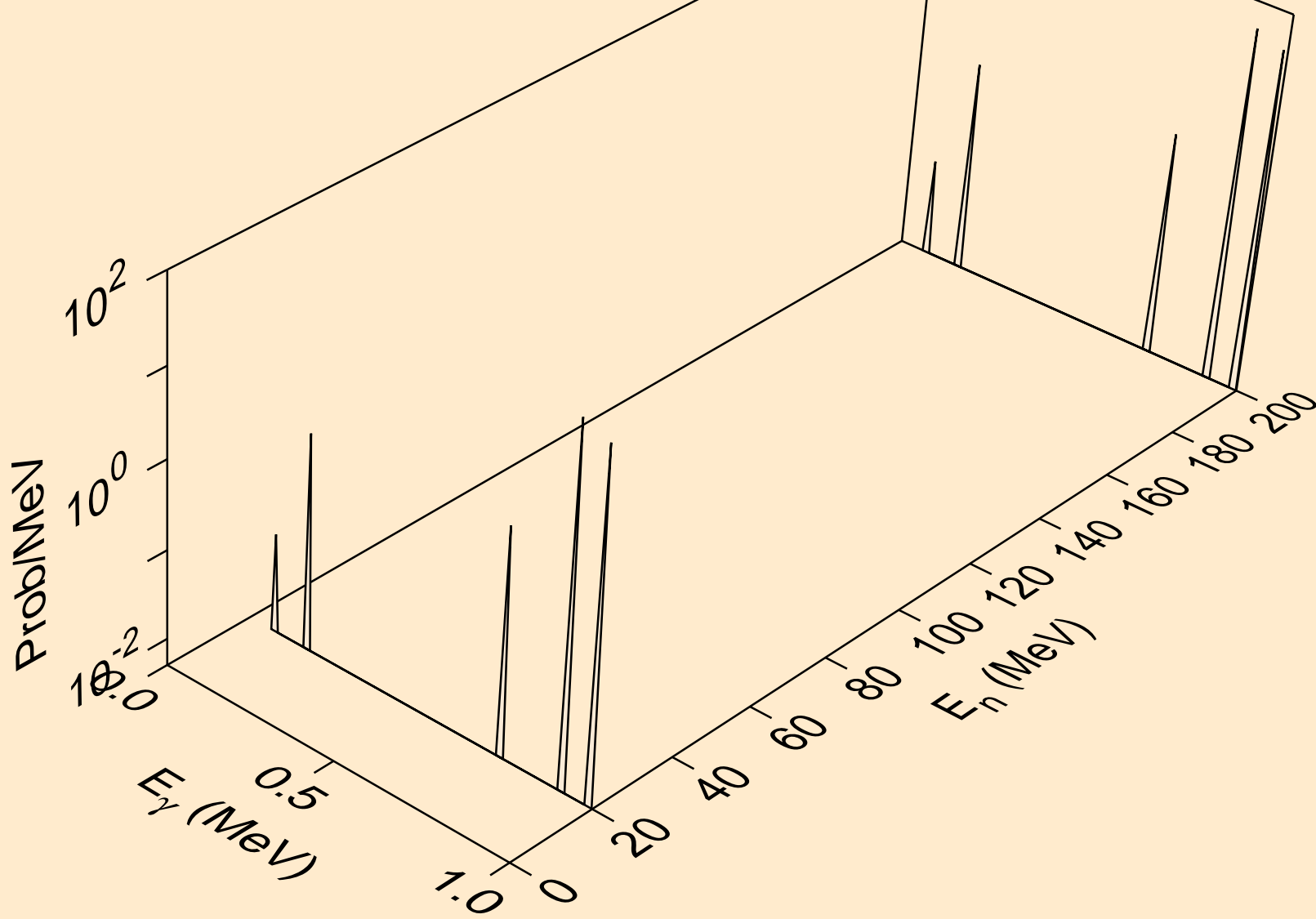



64-GD-160 FOR FENDL-3.1 FROM FENDL-3.1 WITH NJOY2012.50  
Photon emission for (n,n\*8)

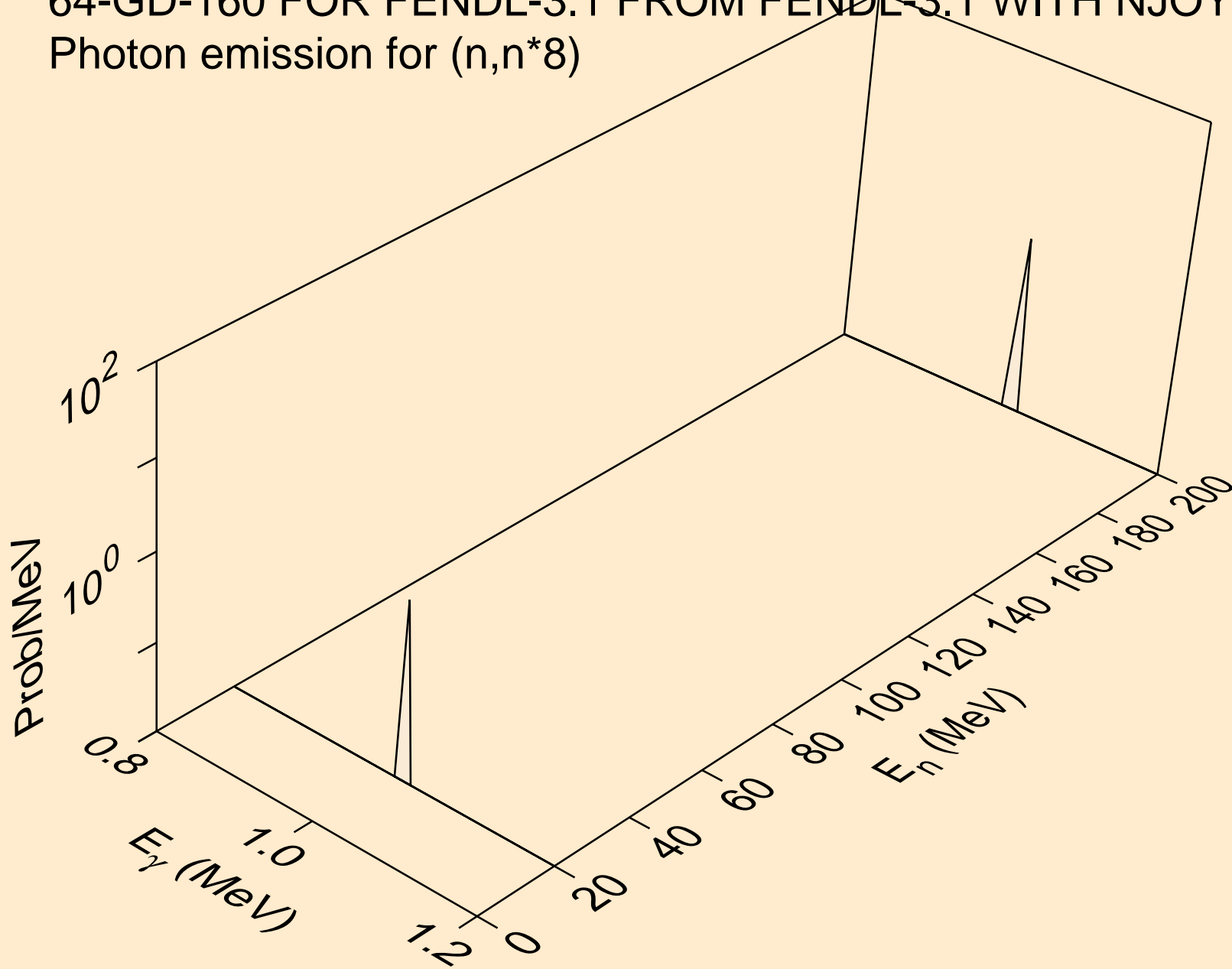

64-GD-160 FOR FENDL-3.1 FROM FENDL-3.1 WITH NJOY2012.50  
Photon emission for (n,n\*9)

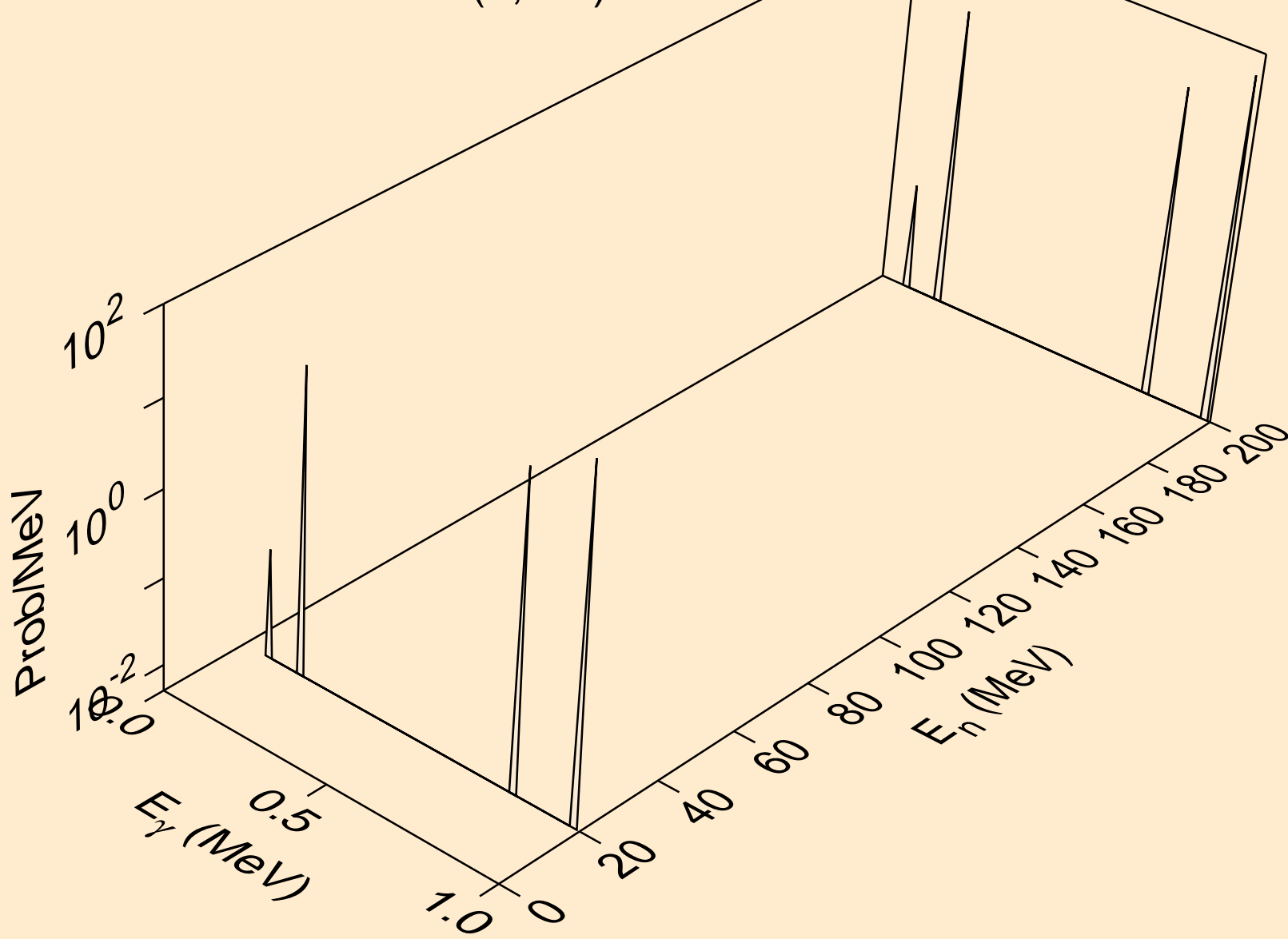

64-GD-160 FOR FENDL-3.1 FROM FENDL-3.1 WITH NJOY2012.50  
Photon emission for (n,n\*10)

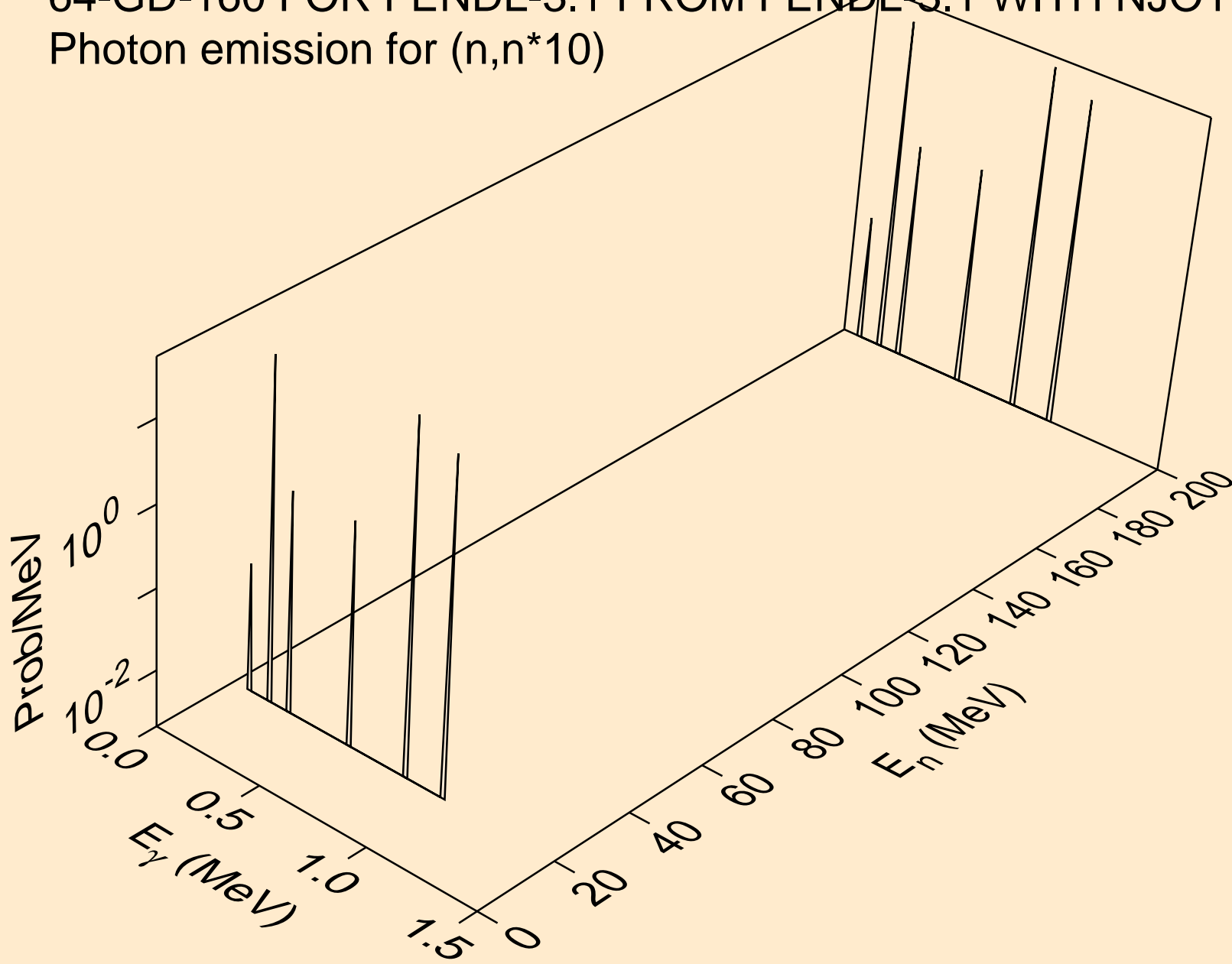

64-GD-160 FOR FENDL-3.1 FROM FENDL-3.1 WITH NJOY2012.50  
Photon emission for (n,n\*11)

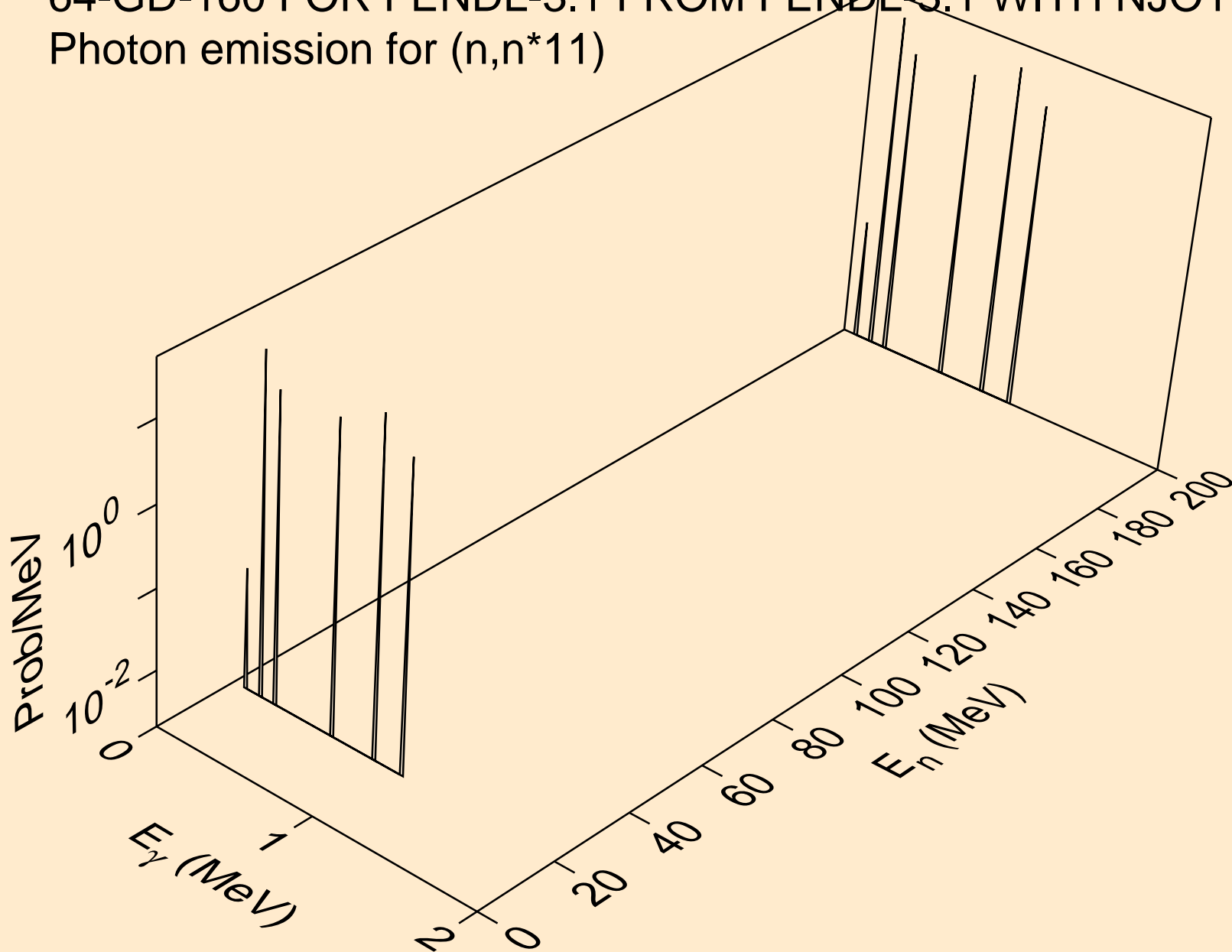

64-GD-160 FOR FENDL-3.1 FROM FENDL-3.1 WITH NJOY2012.50  
Photon emission for (n,n\*12)

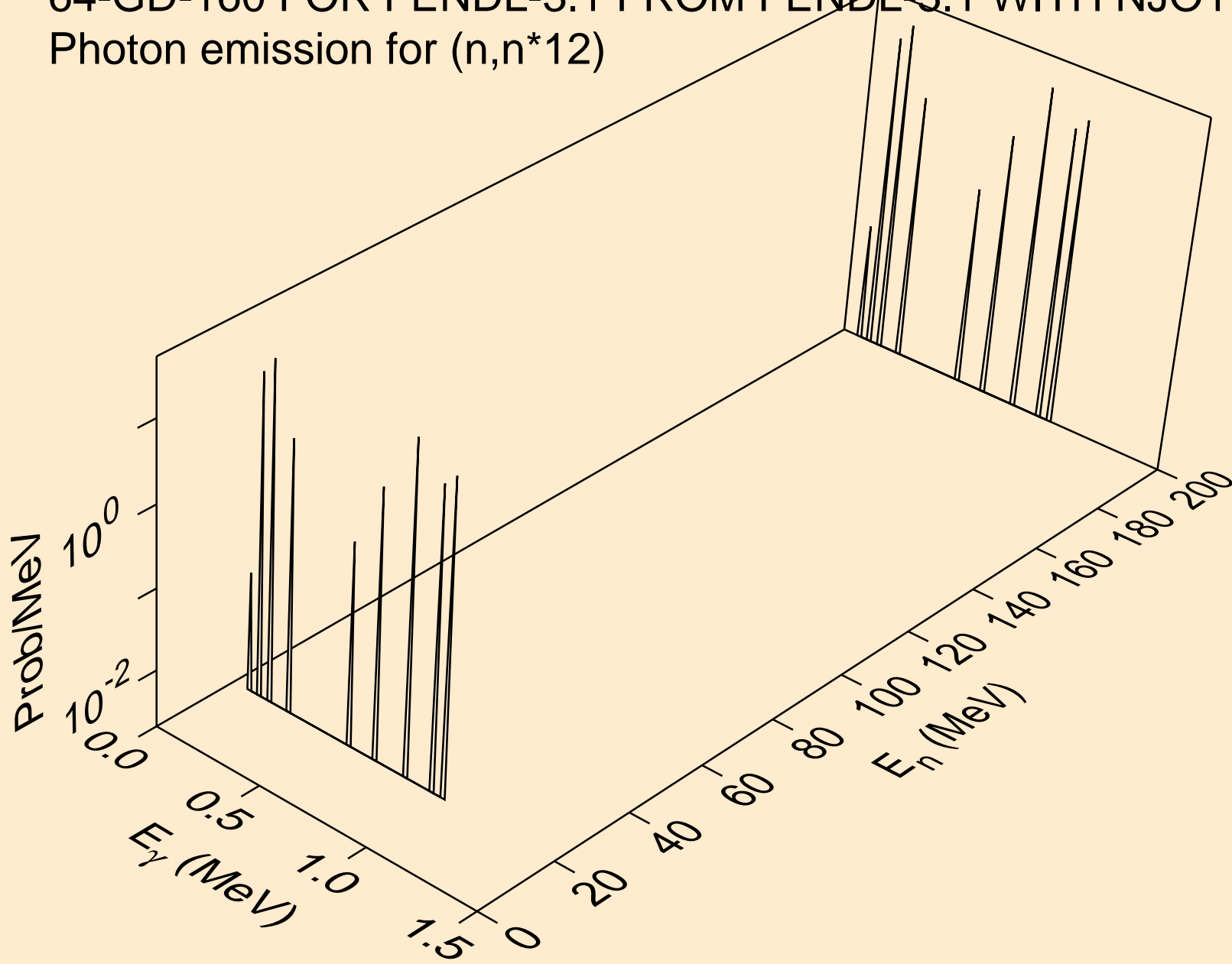

64-GD-160 FOR FENDL-3.1 FROM FENDL-3.1 WITH NJOY2012.50  
Photon emission for (n,n\*13)

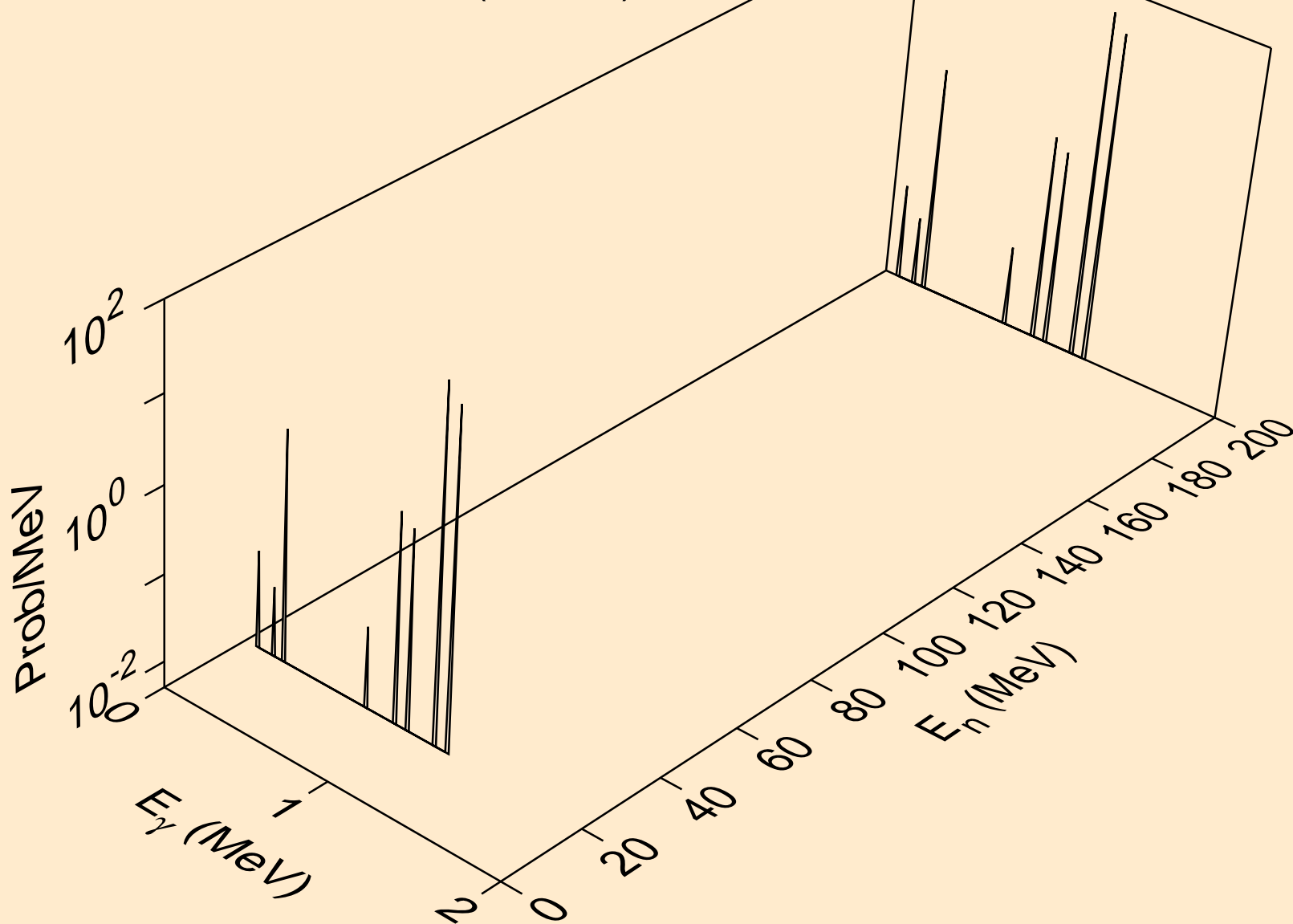

64-GD-160 FOR FENDL-3.1 FROM FENDL-3.1 WITH NJOY2012.50  
Photon emission for (n,n\*14)

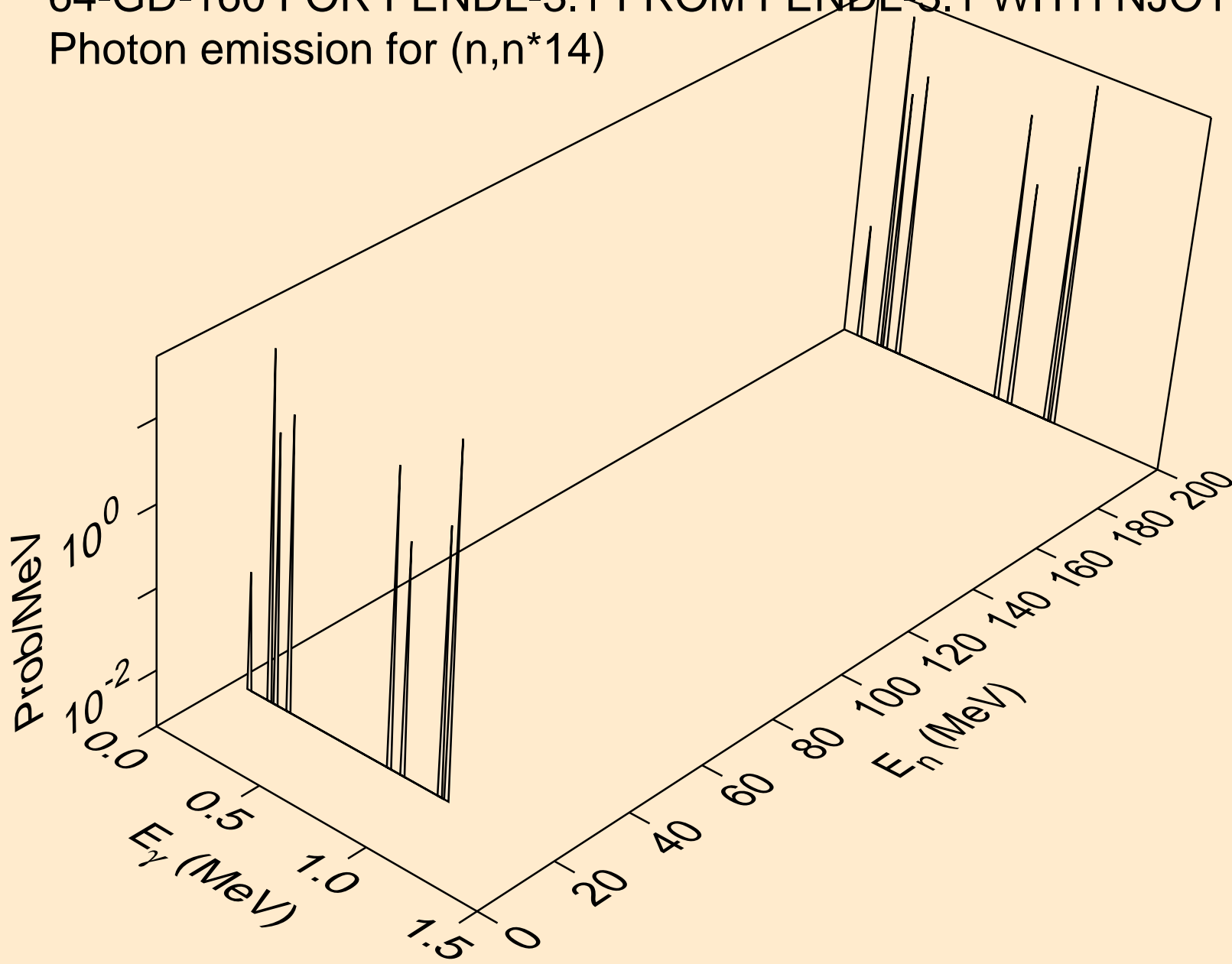

64-GD-160 FOR FENDL-3.1 FROM FENDL-3.1 WITH NJOY2012.50  
Photon emission for (n,n\*15)

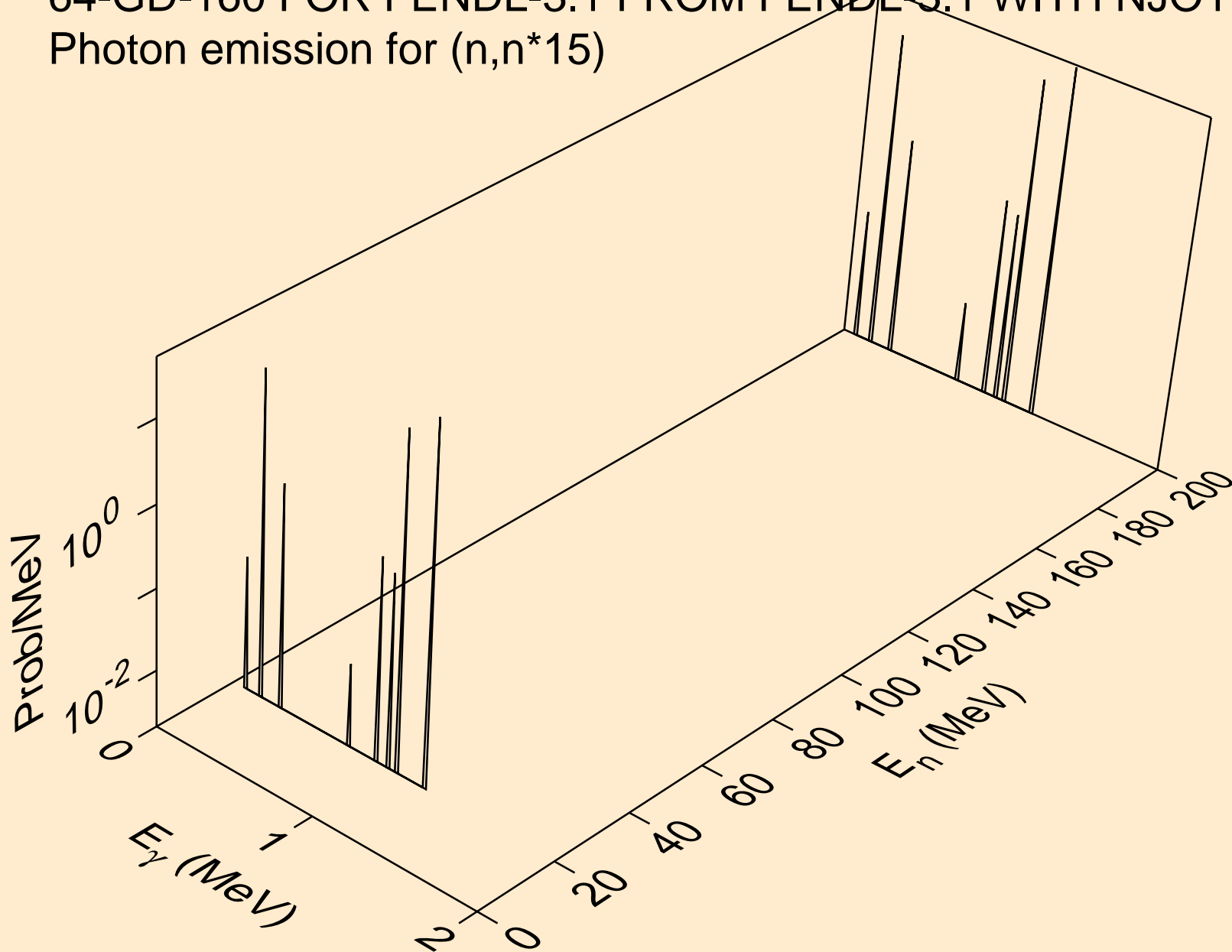



64-GD-160 FOR FENDL-3.1 FROM FENDL-3.1 WITH NJOY2012.50  
Photon emission for (n,n\*16)

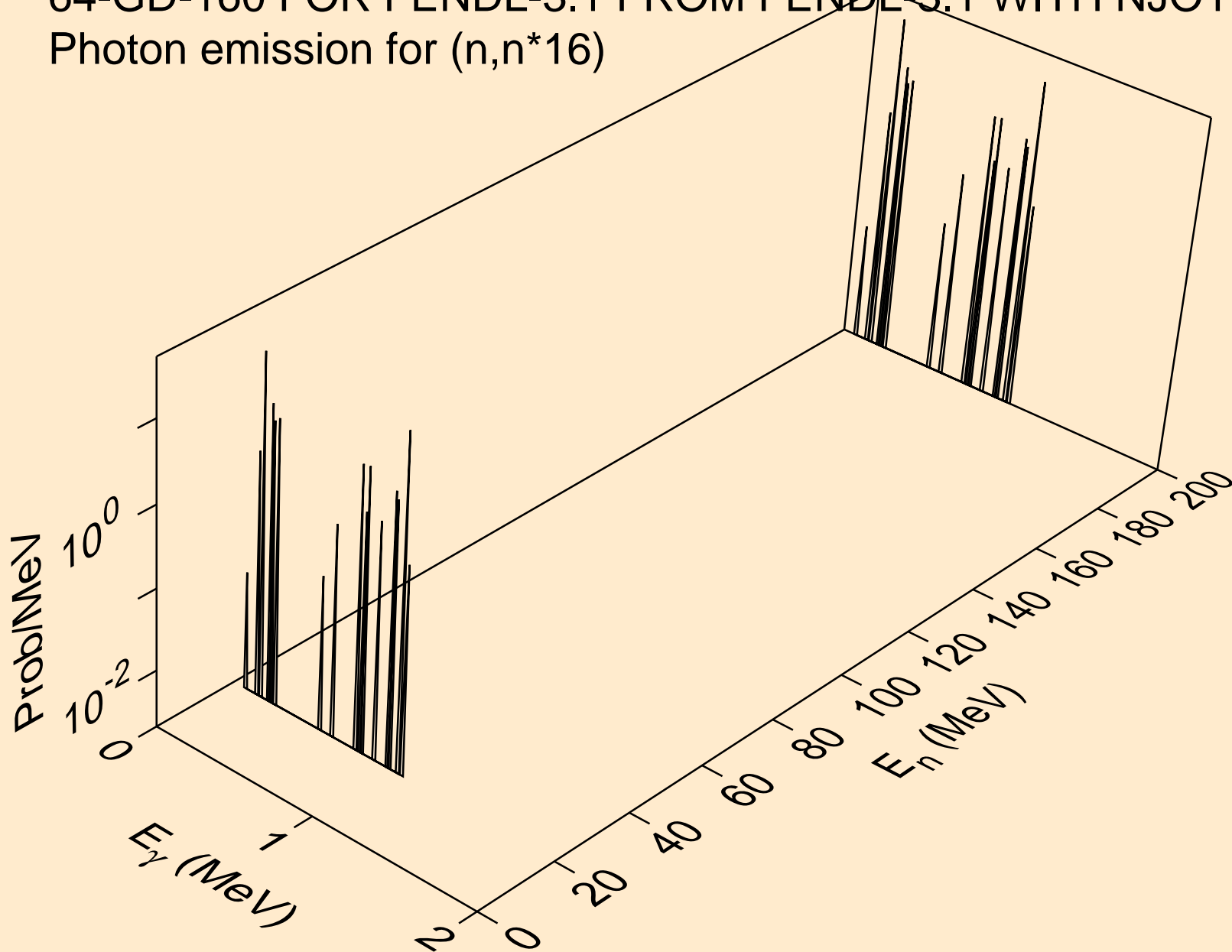

64-GD-160 FOR FENDL-3.1 FROM FENDL-3.1 WITH NJOY2012.50  
Photon emission for (n,n\*17)

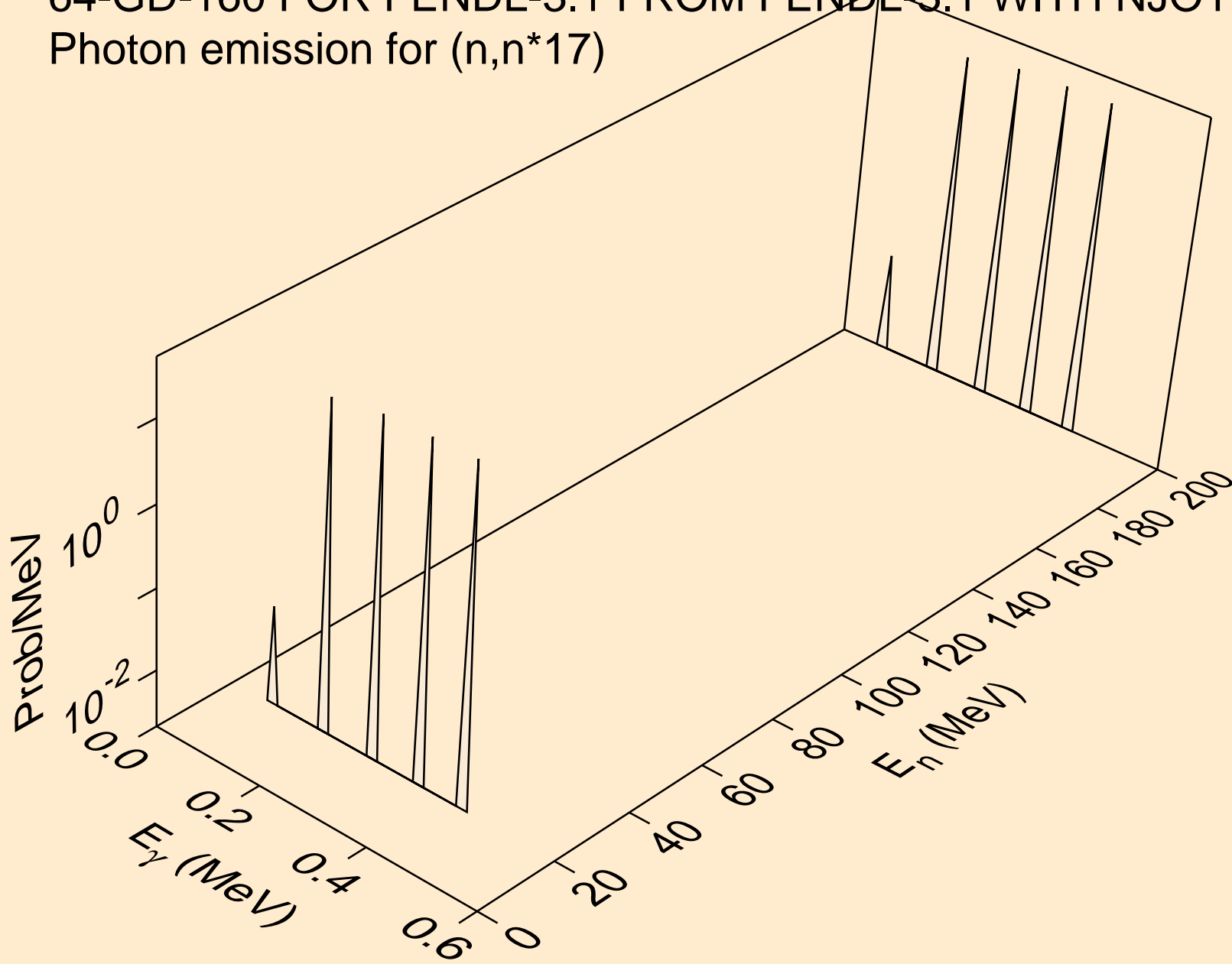

64-GD-160 FOR FENDL-3.1 FROM FENDL-3.1 WITH NJOY2012.50  
Photon emission for (n,n\*18)

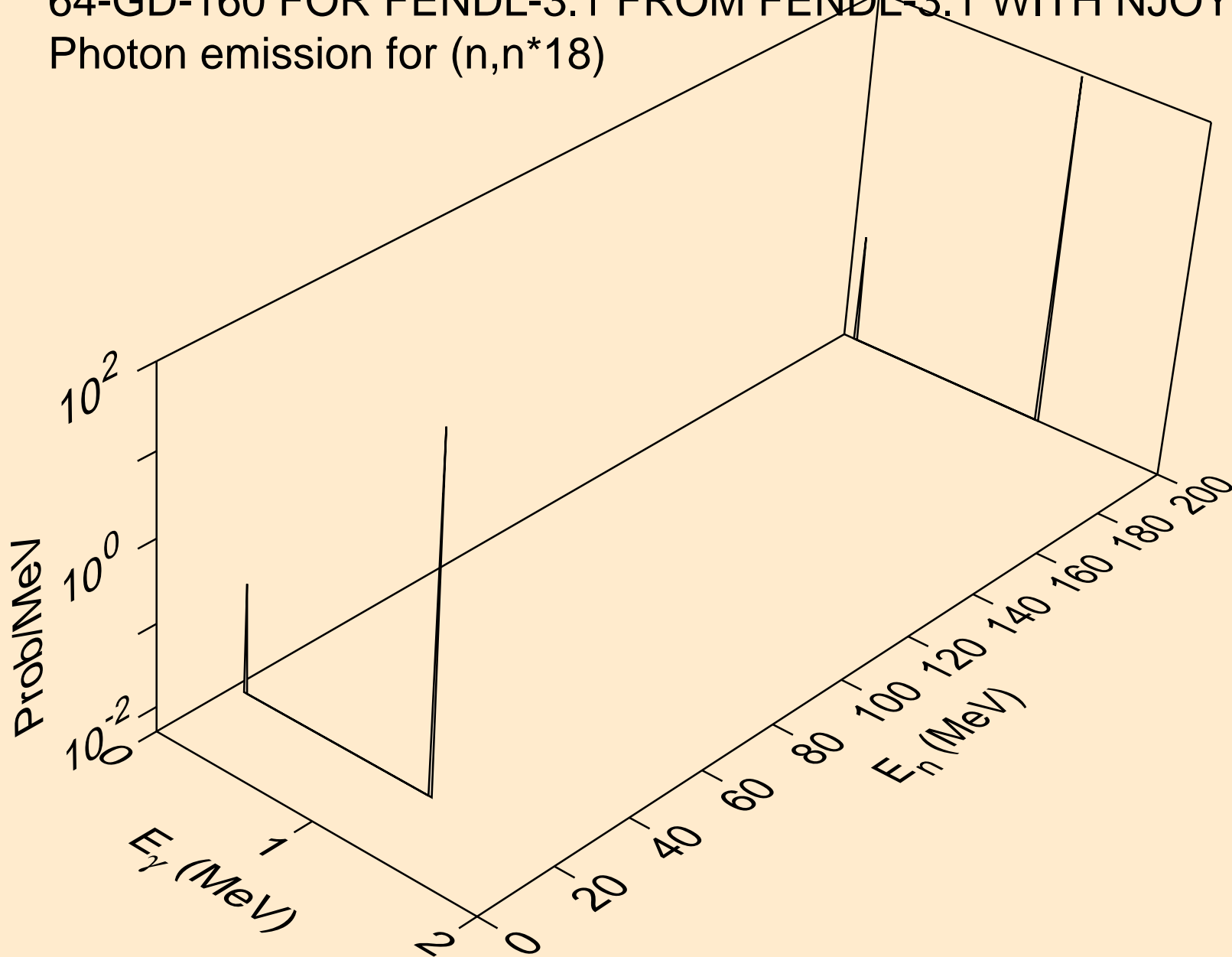

64-GD-160 FOR FENDL-3.1 FROM FENDL-3.1 WITH NJOY2012.50  
Photon emission for (n,n\*19)

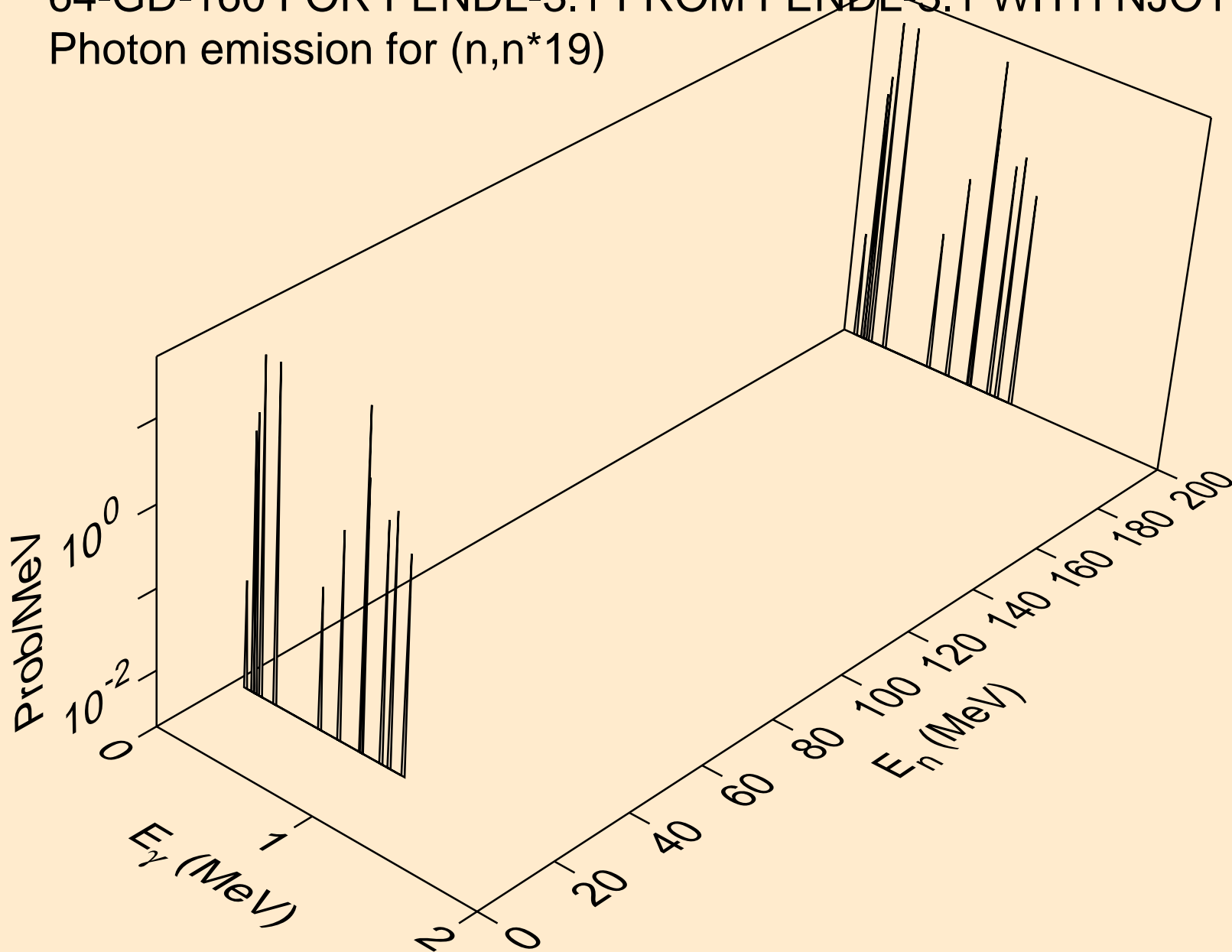

64-GD-160 FOR FENDL-3.1 FROM FENDL-3.1 WITH NJOY2012.50  
Photon emission for (n,n\*20)

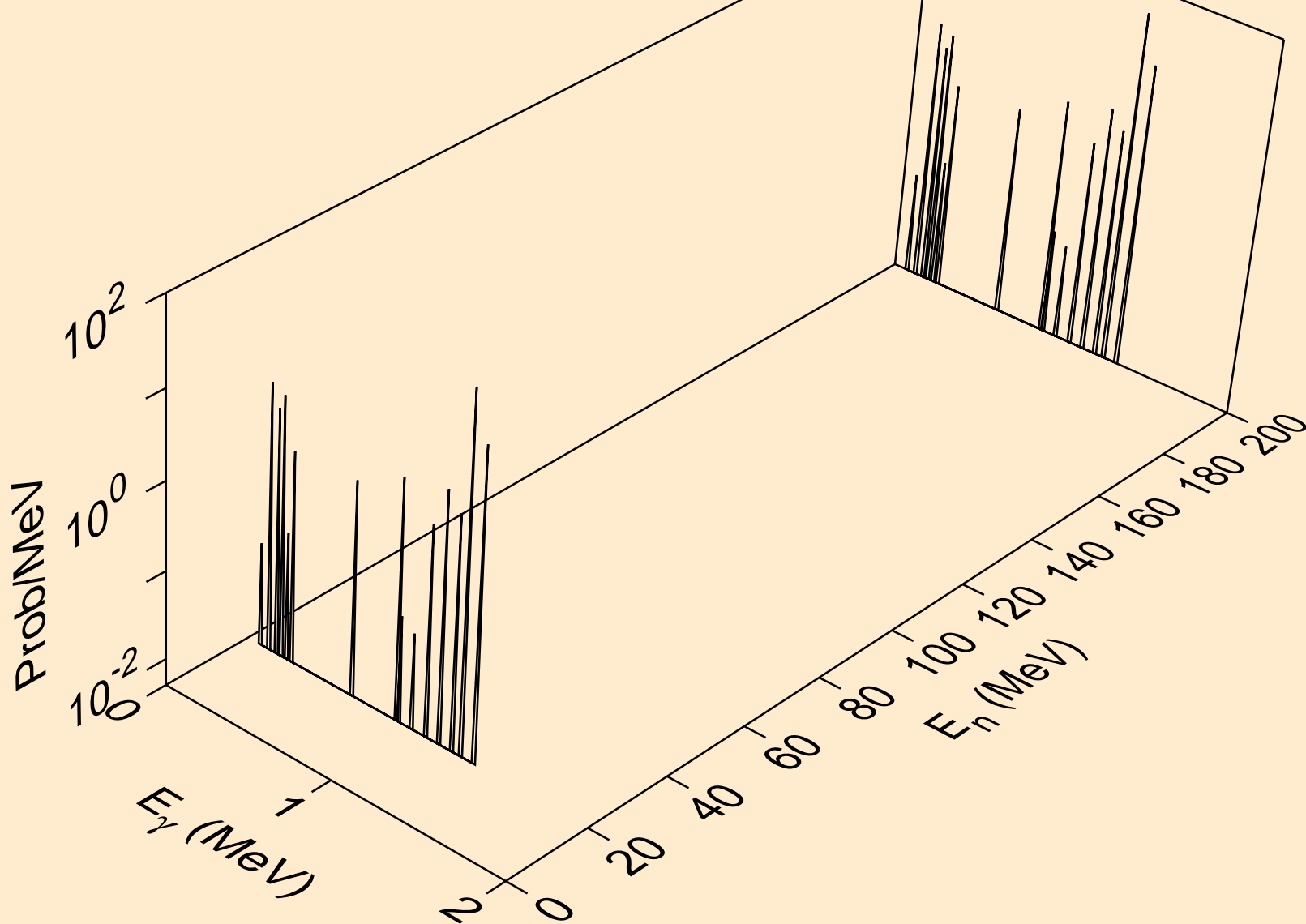

64-GD-160 FOR FENDL-3.1 FROM FENDL-3.1 WITH NJOY2012.50  
Photon emission for (n,n\*21)

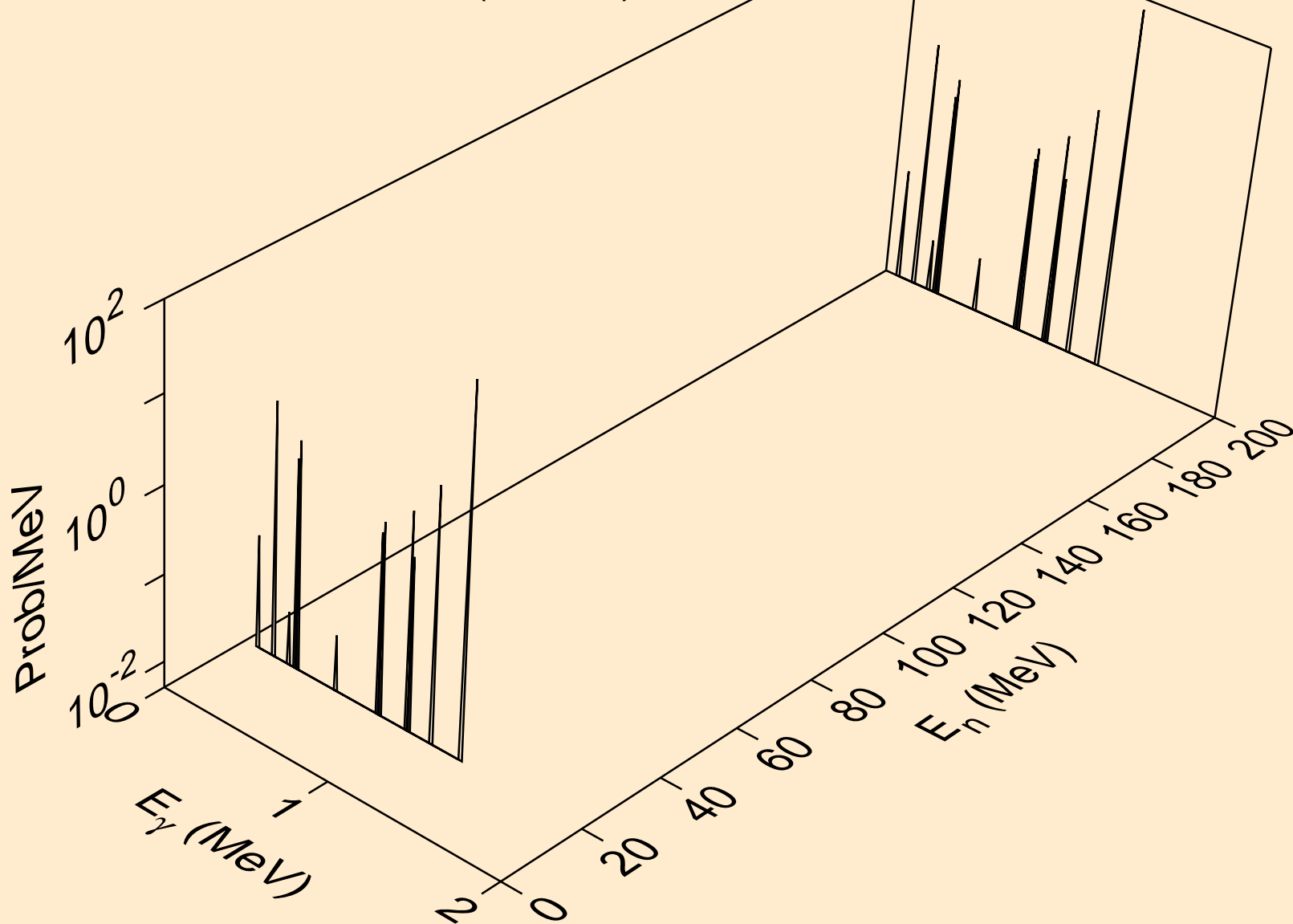

64-GD-160 FOR FENDL-3.1 FROM FENDL-3.1 WITH NJOY2012.50  
Photon emission for (n,n\*22)

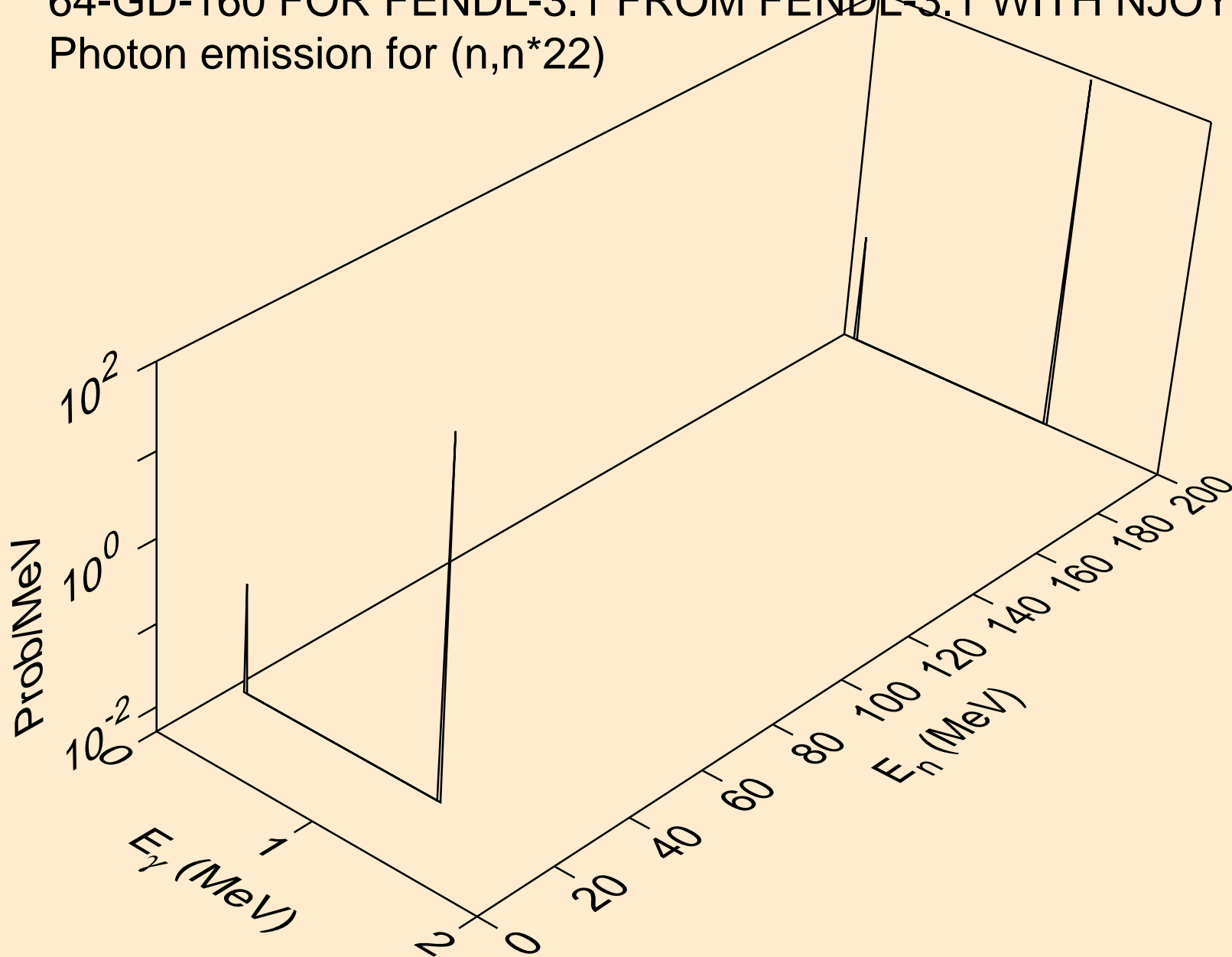

64-GD-160 FOR FENDL-3.1 FROM FENDL-3.1 WITH NJOY2012.50  
Photon emission for (n,n\*23)

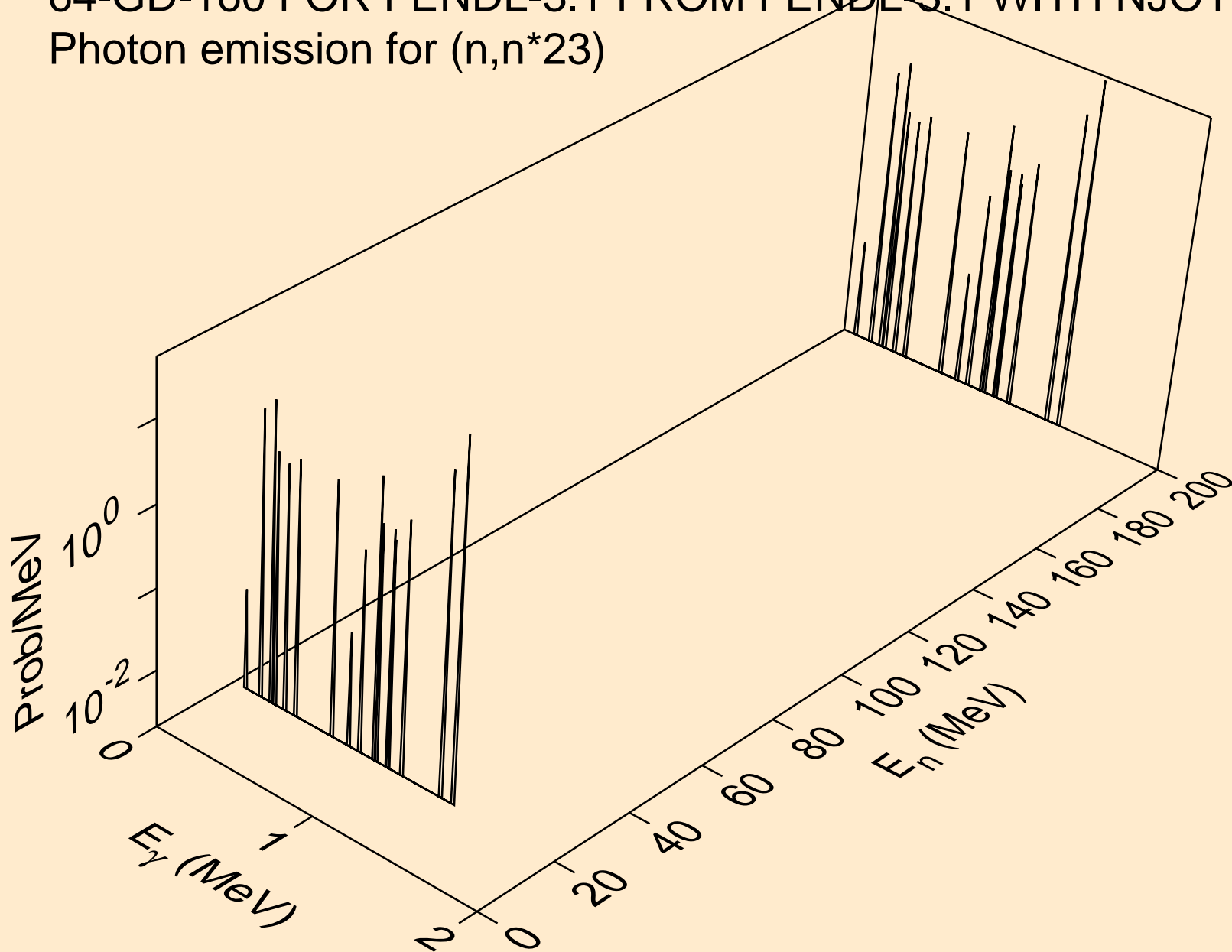



64-GD-160 FOR FENDL-3.1 FROM FENDL-3.1 WITH NJOY2012.50  
Photon emission for (n,n\*24)

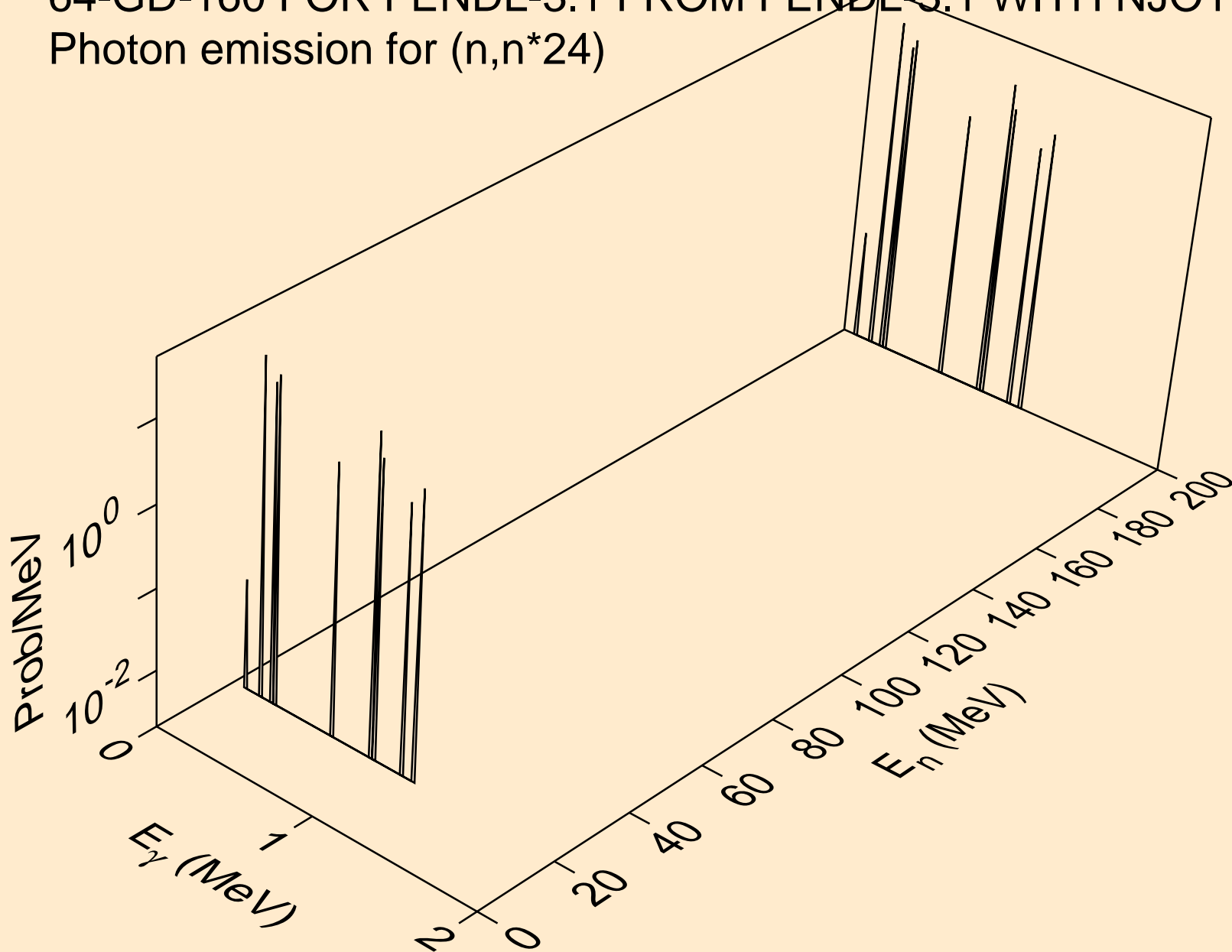

64-GD-160 FOR FENDL-3.1 FROM FENDL-3.1 WITH NJOY2012.50  
Photon emission for (n,n\*25)

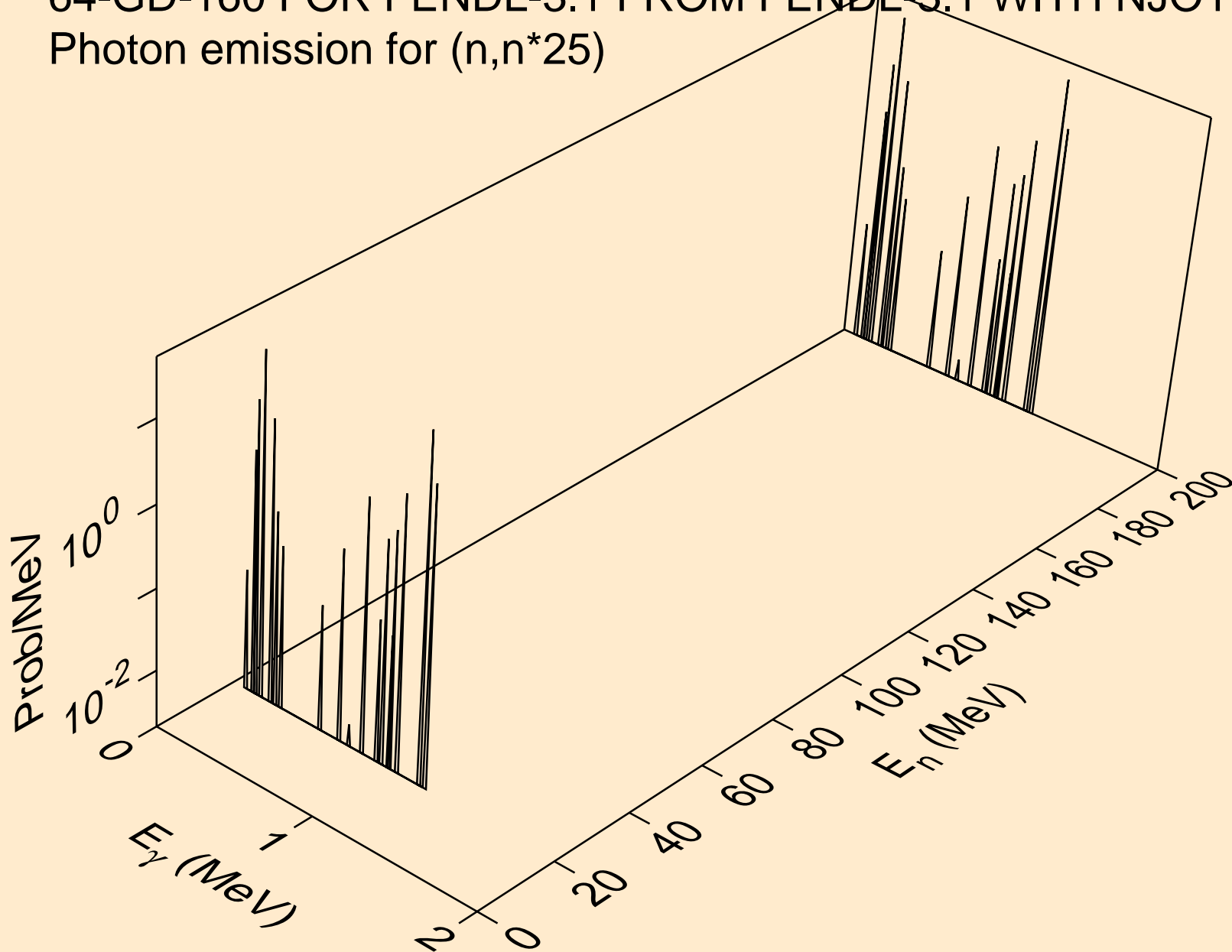

64-GD-160 FOR FENDL-3.1 FROM FENDL-3.1 WITH NJOY2012.50  
Photon emission for (n,n\*26)

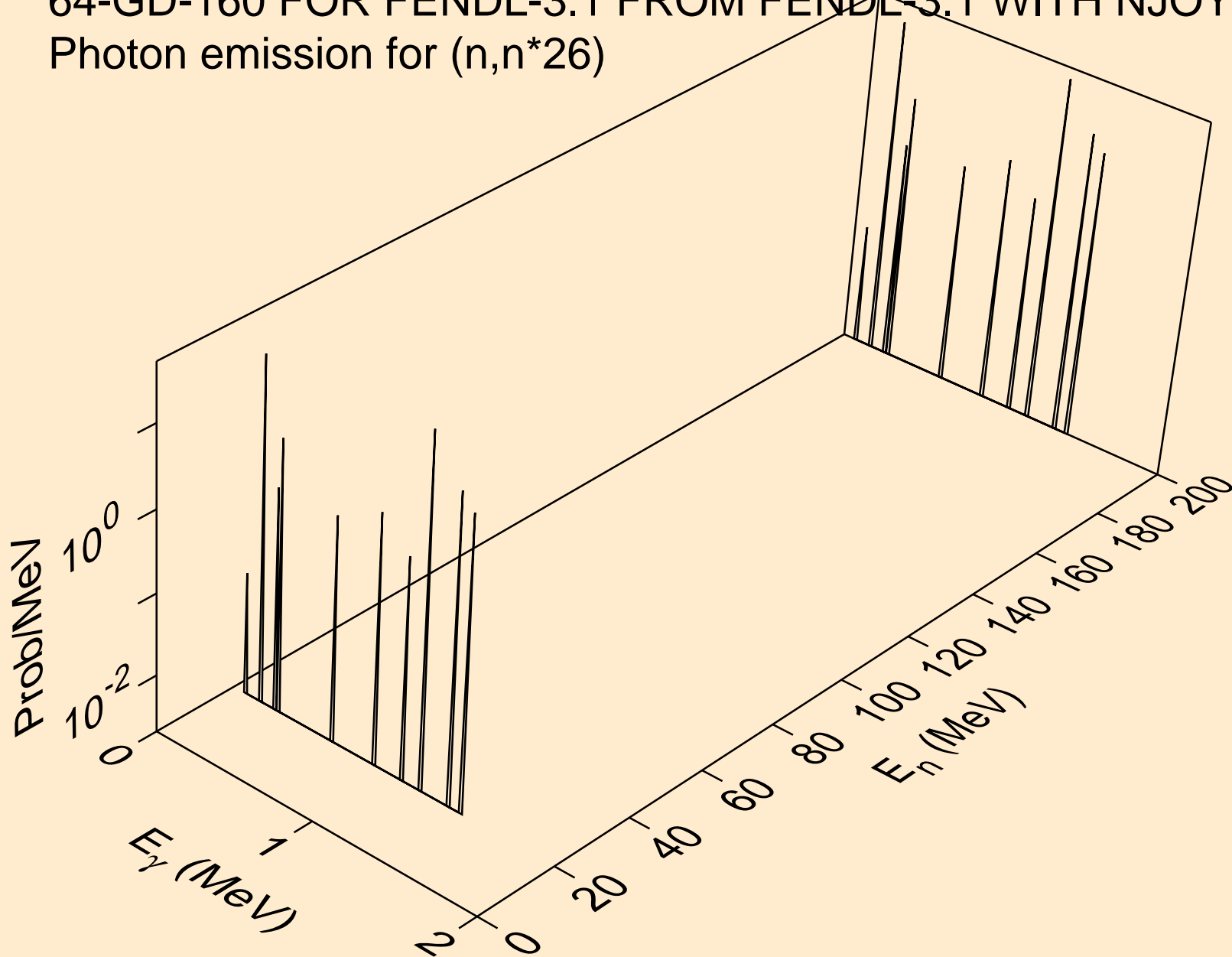

64-GD-160 FOR FENDL-3.1 FROM FENDL-3.1 WITH NJOY2012.50  
Photon emission for (n,n\*27)

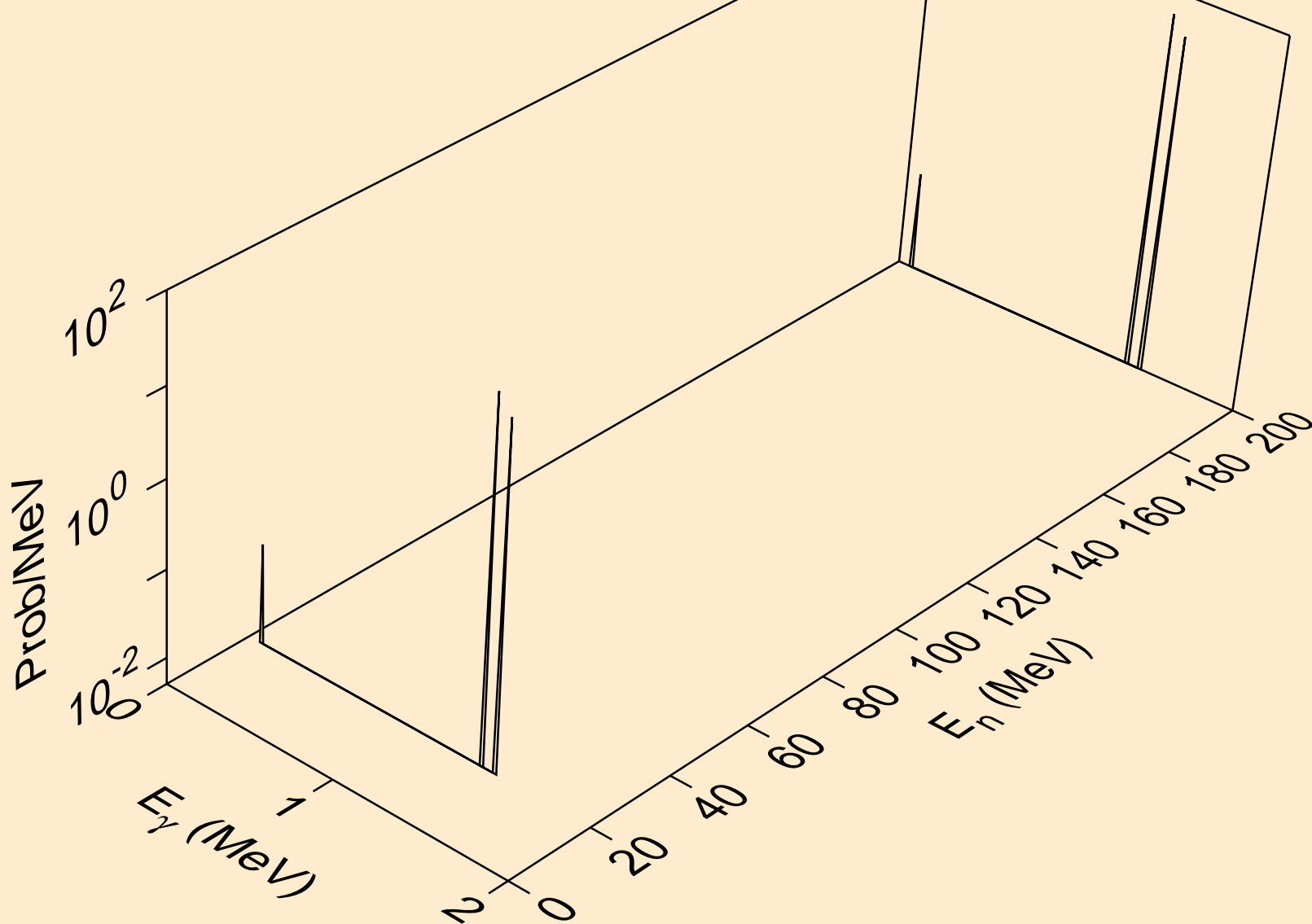

64-GD-160 FOR FENDL-3.1 FROM FENDL-3.1 WITH NJOY2012.50  
Photon emission for (n,n\*c)

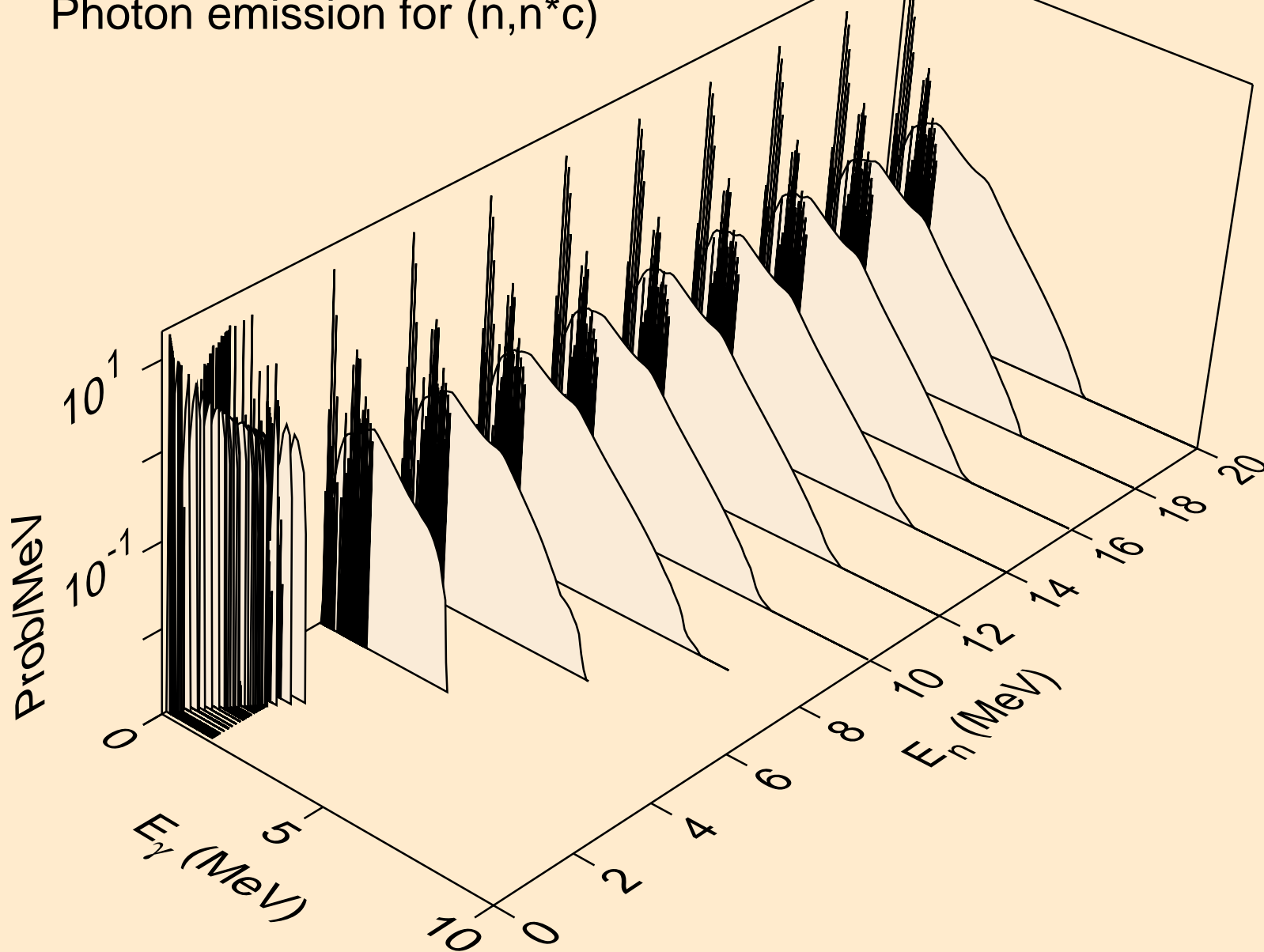

64-GD-160 FOR FENDL-3.1 FROM FENDL-3.1 WITH NJOY2012.50  
Photon emission for (n,gma)

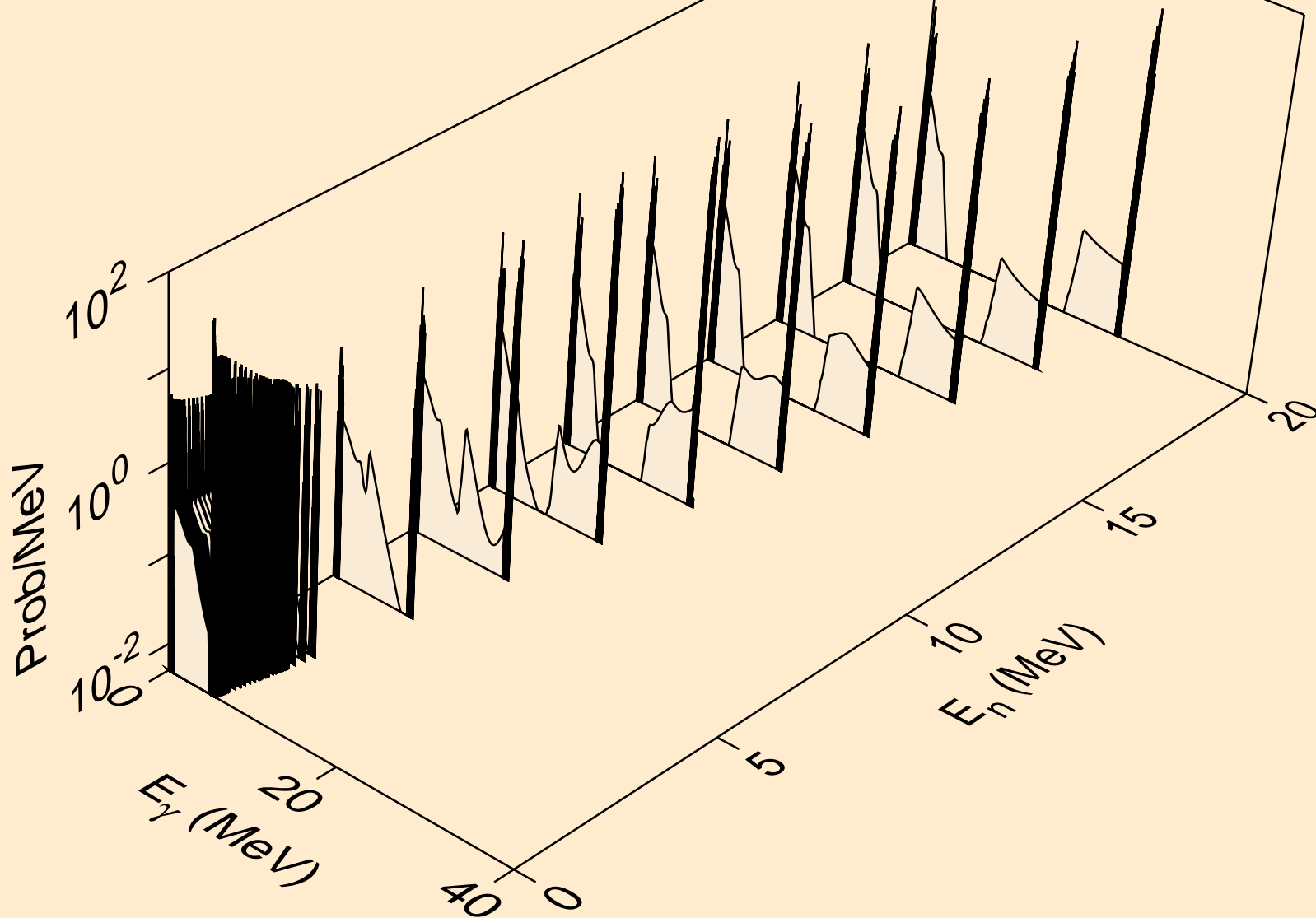

64-GD-160 FOR FENDL-3.1 FROM FENDL-3.1 WITH NJOY2012.50  
thermal capture photon spectrum

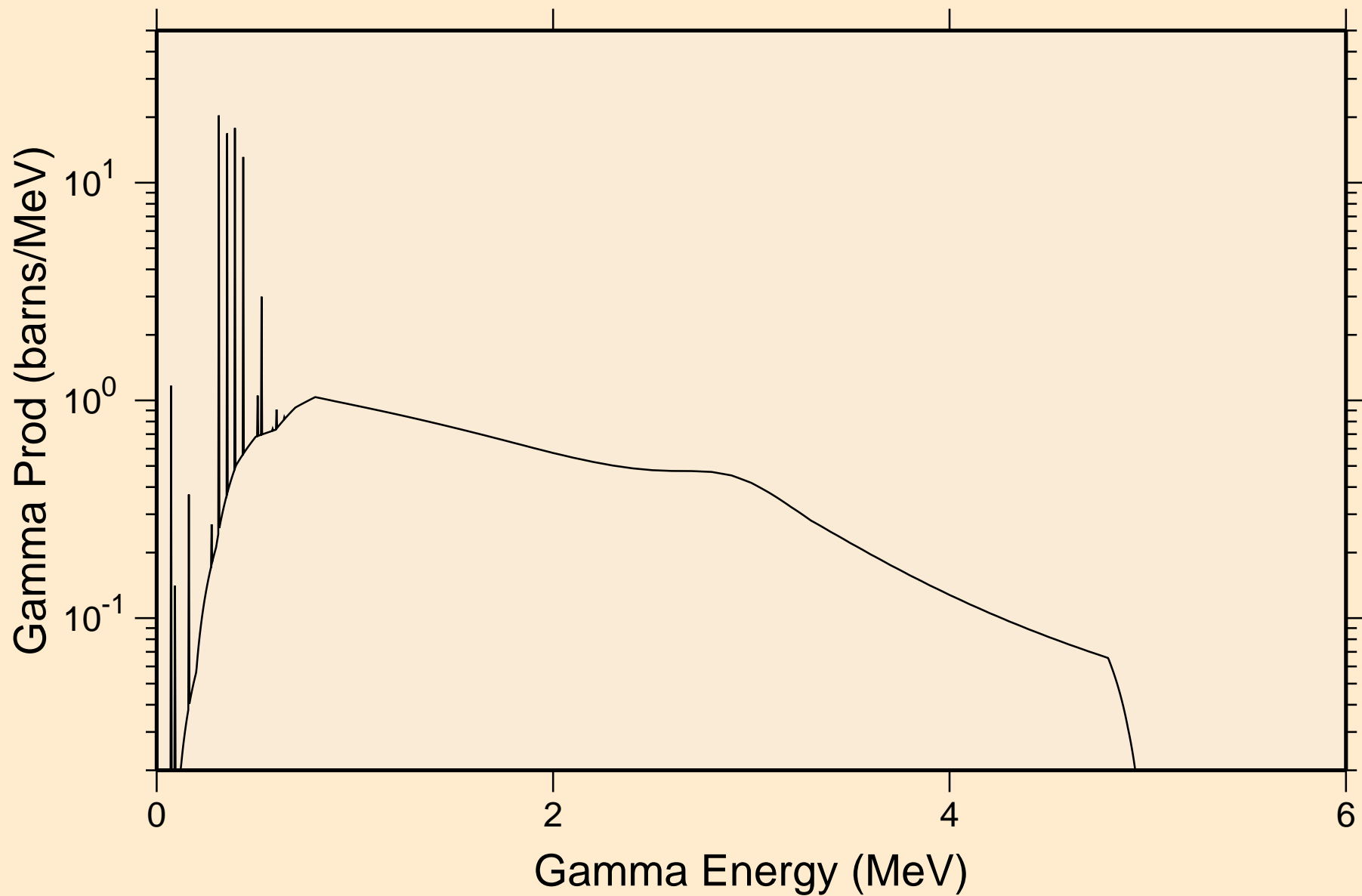

64-GD-160 FOR FENDL-3.1 FROM FENDL-3.1 WITH NJOY2012.50  
14 MeV photon spectrum

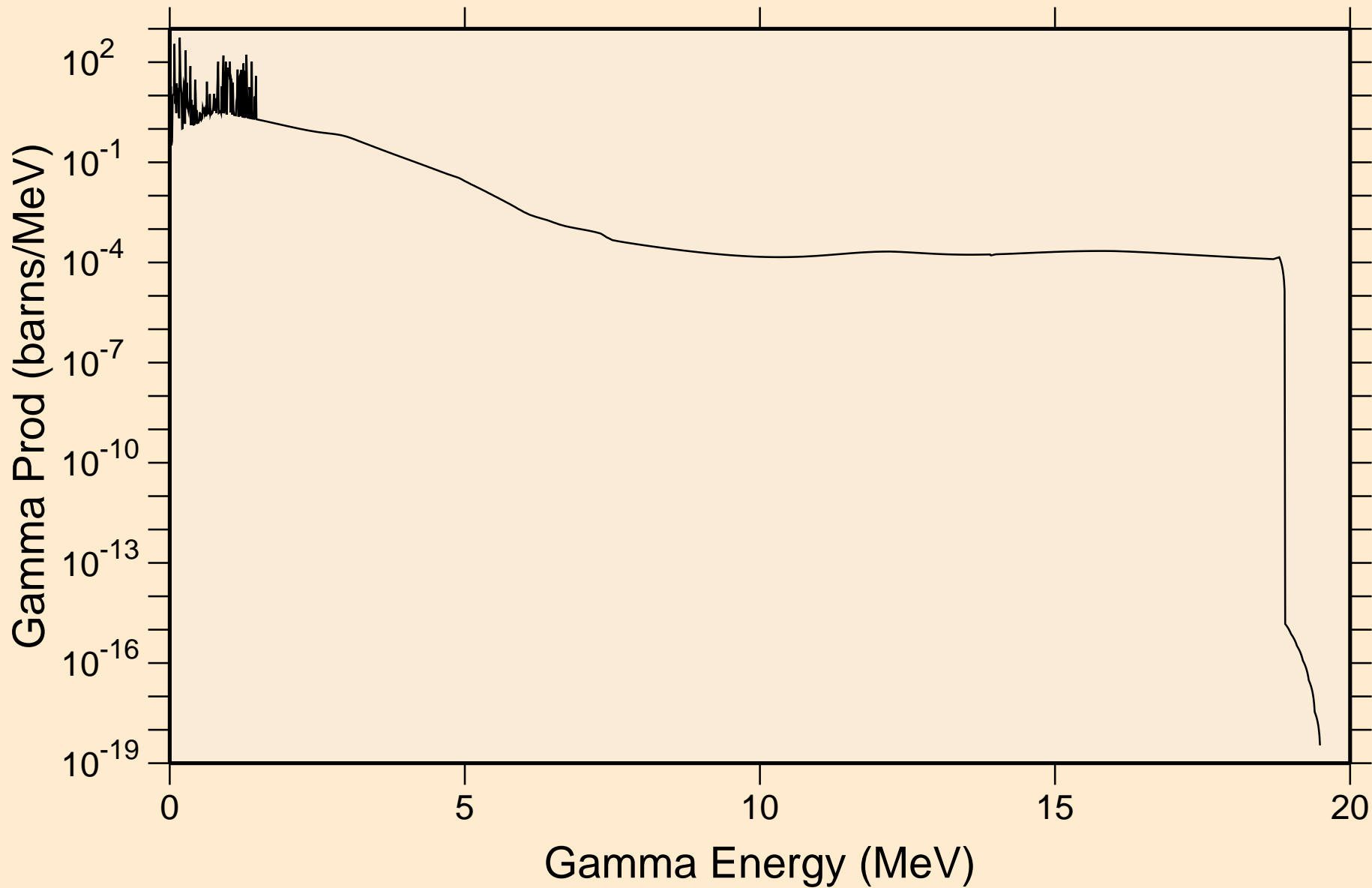



# 64-GD-160 FOR FENDL-3.1 FROM FENDL-3.1 WITH NJOY2012.50

## Particle heating contributions

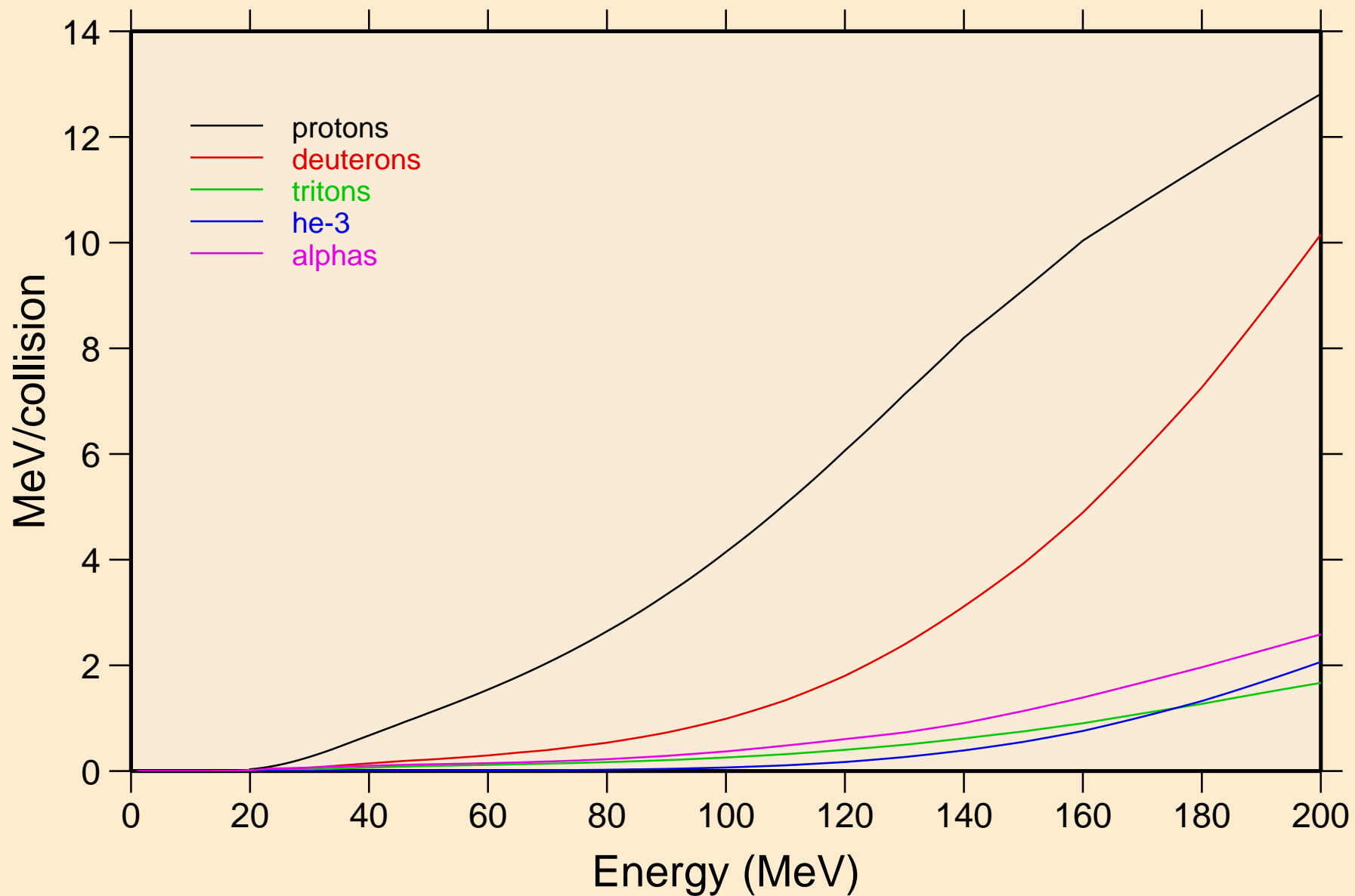

64-GD-160 FOR FENDL-3.1 FROM FENDL-3.1 WITH NJOY2012.50  
Recoil Heating

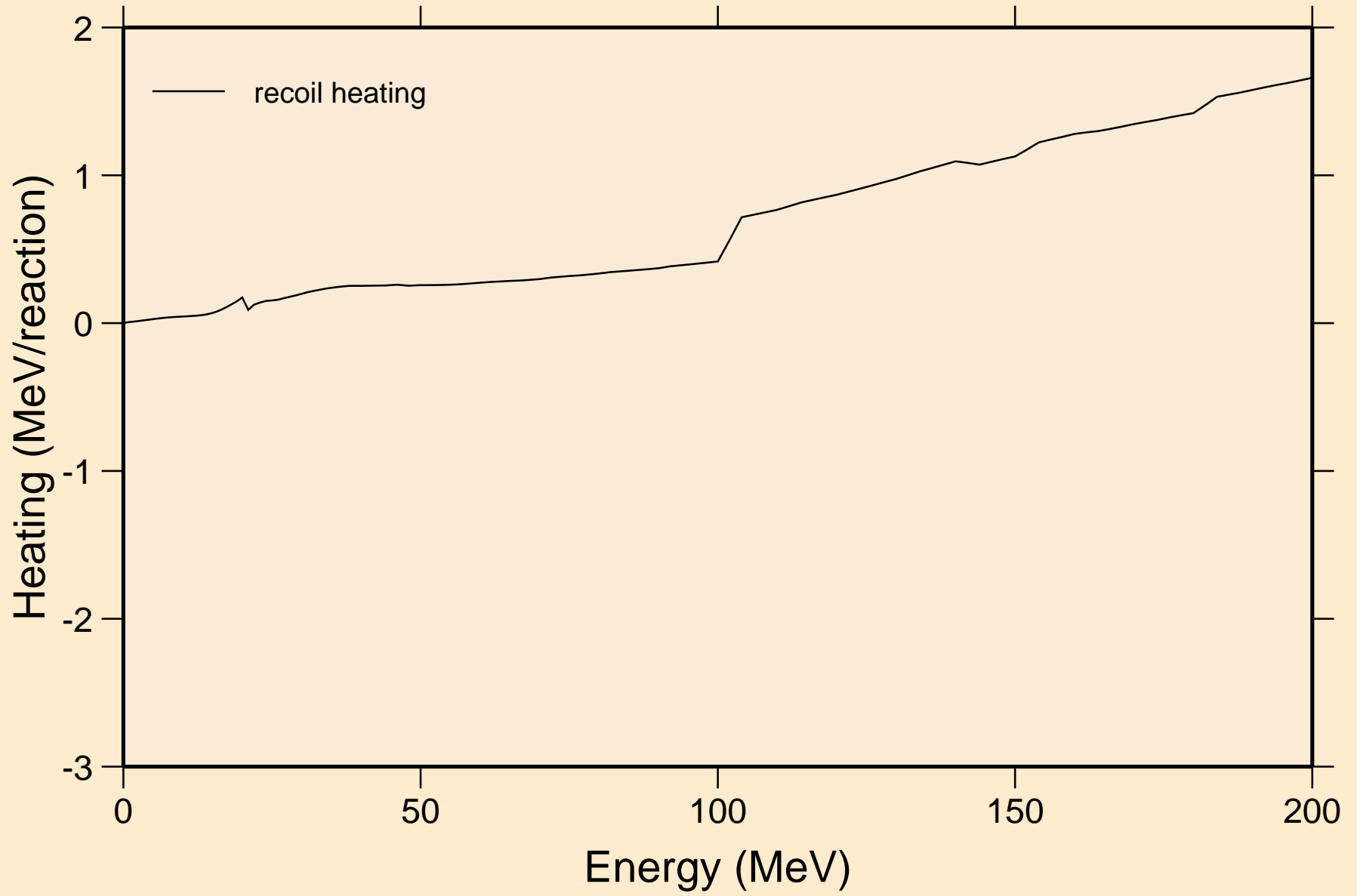

64-GD-160 FOR FENDL-3.1 FROM FENDL-3.1 WITH NJOY2012.50  
Particle production cross sections

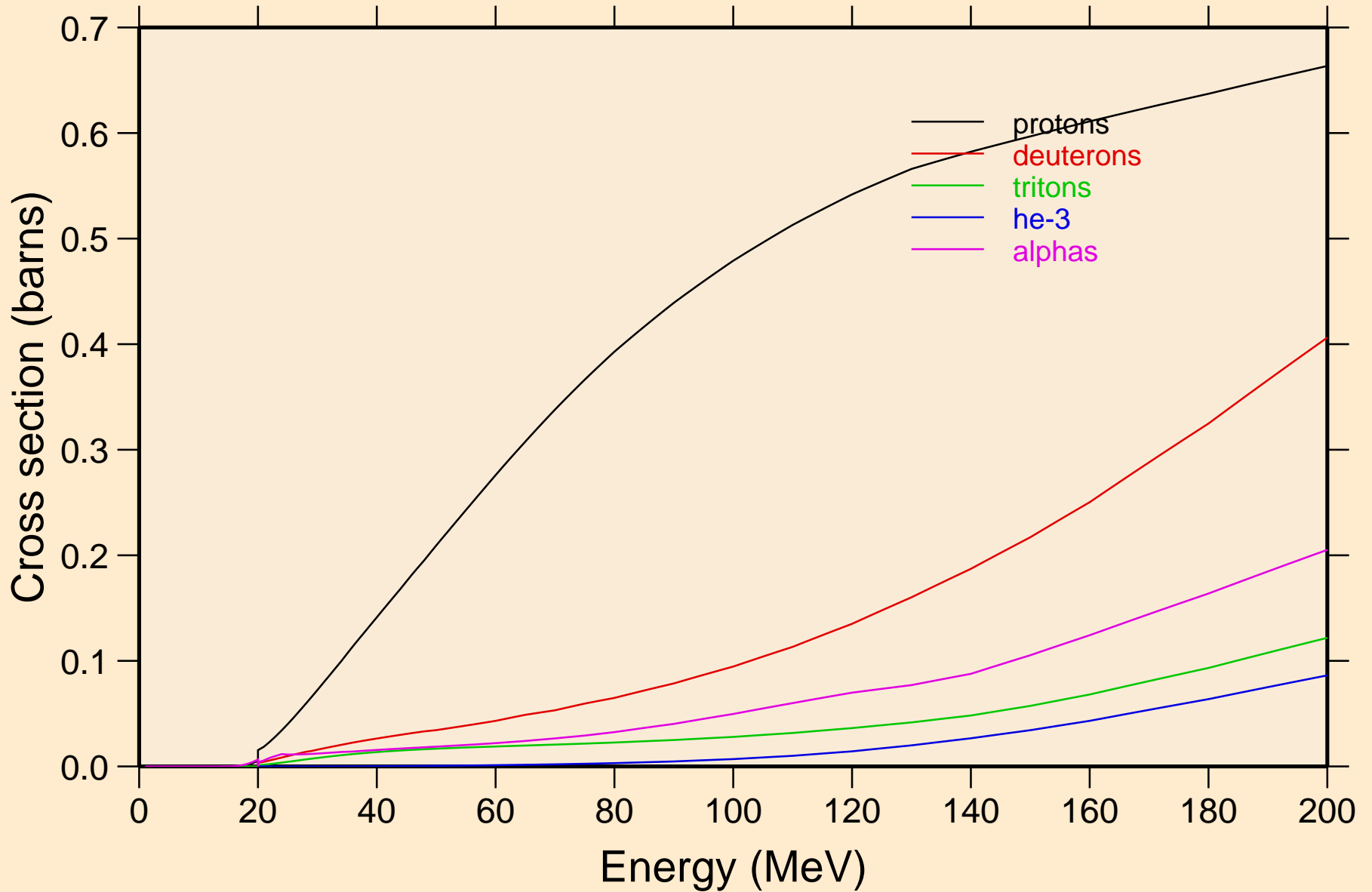

64-GD-160 FOR FENDL-3.1 FROM FENDL-3.1 WITH NJOY2012.50  
protons from (n,x)

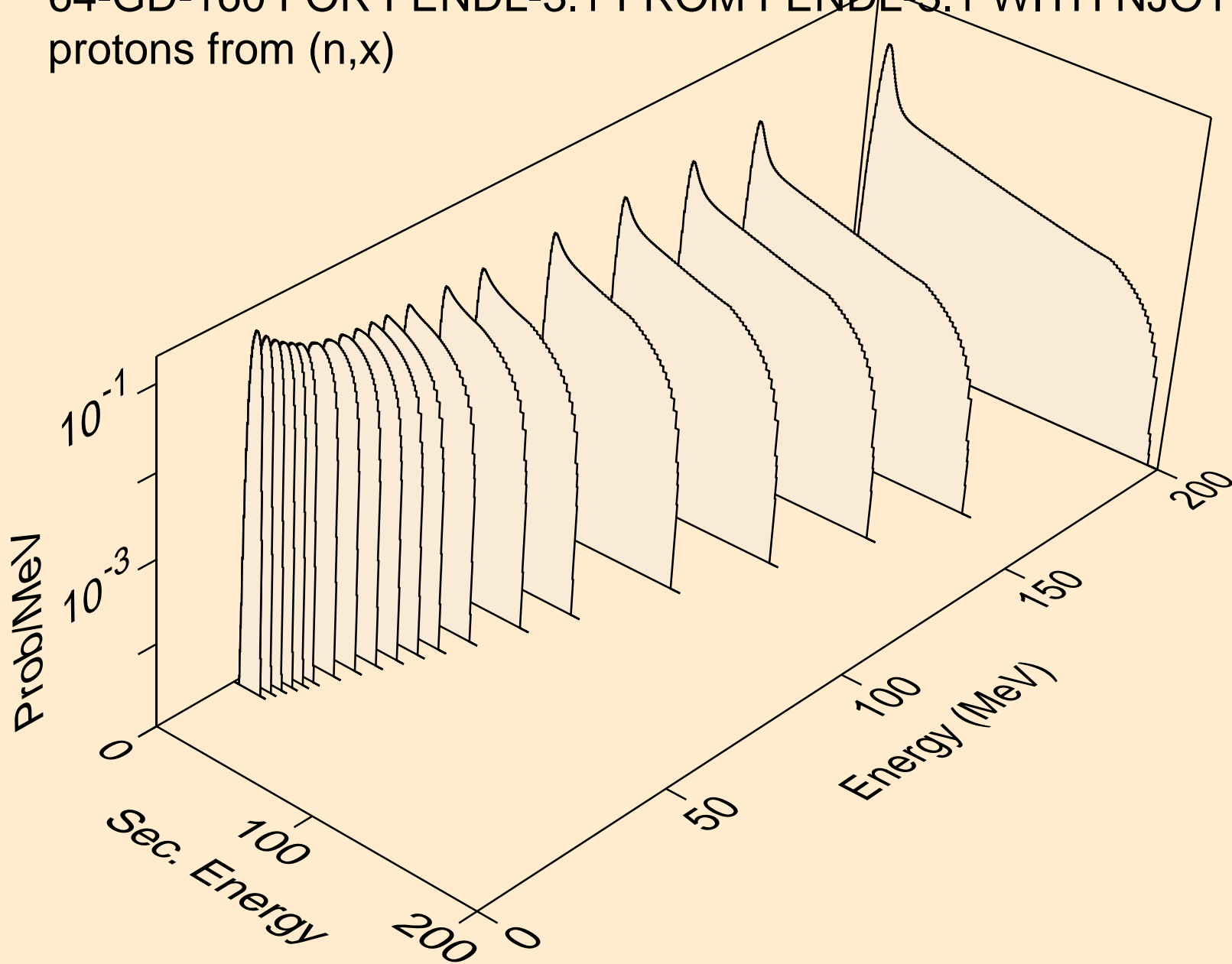

64-GD-160 FOR FENDL-3.1 FROM FENDL-3.1 WITH NJOY2012.50  
protons from (n,n\*)p

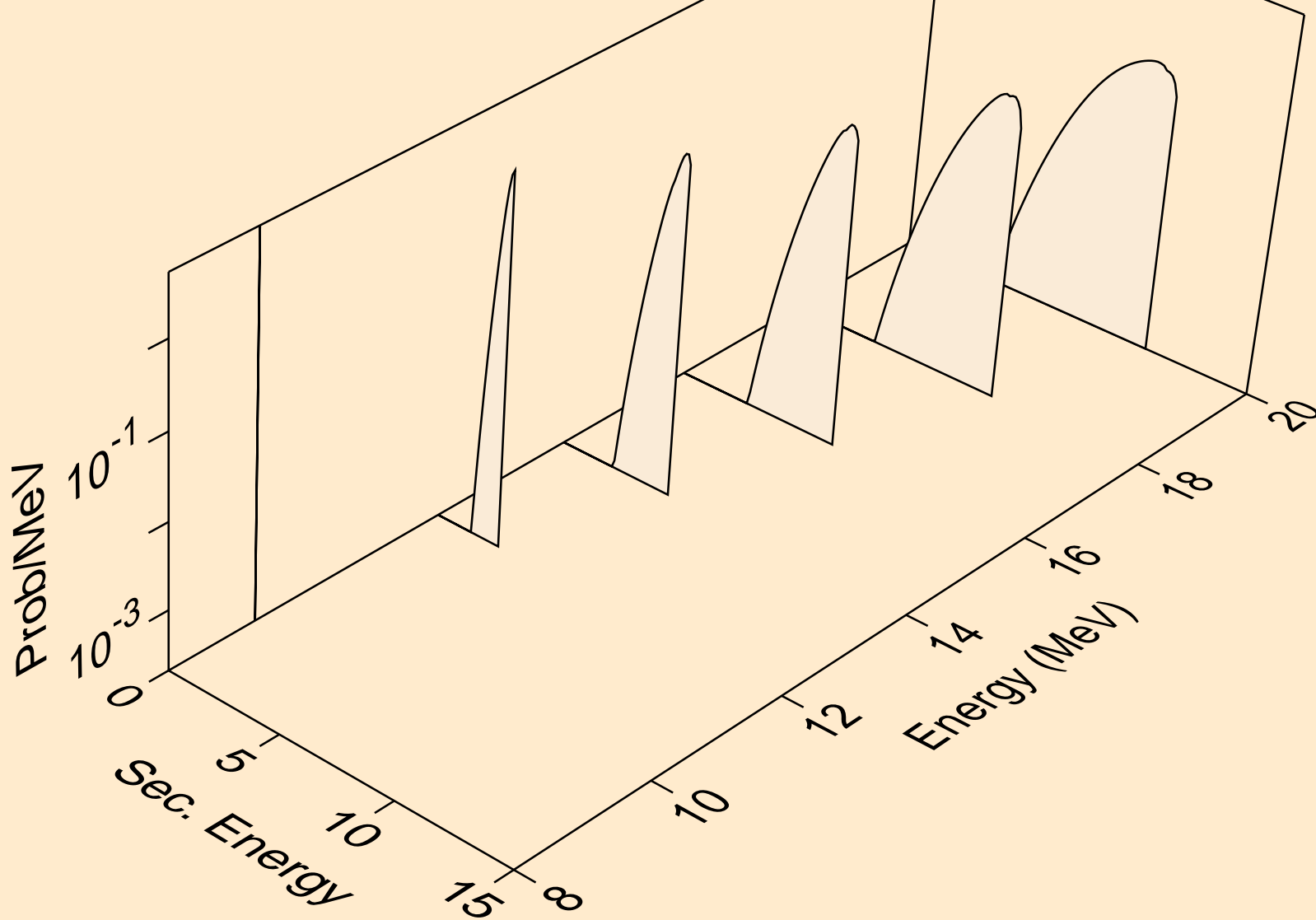

64-GD-160 FOR FENDL-3.1 FROM FENDL-3.1 WITH NJOY2012.50  
deuterons from (n,x)

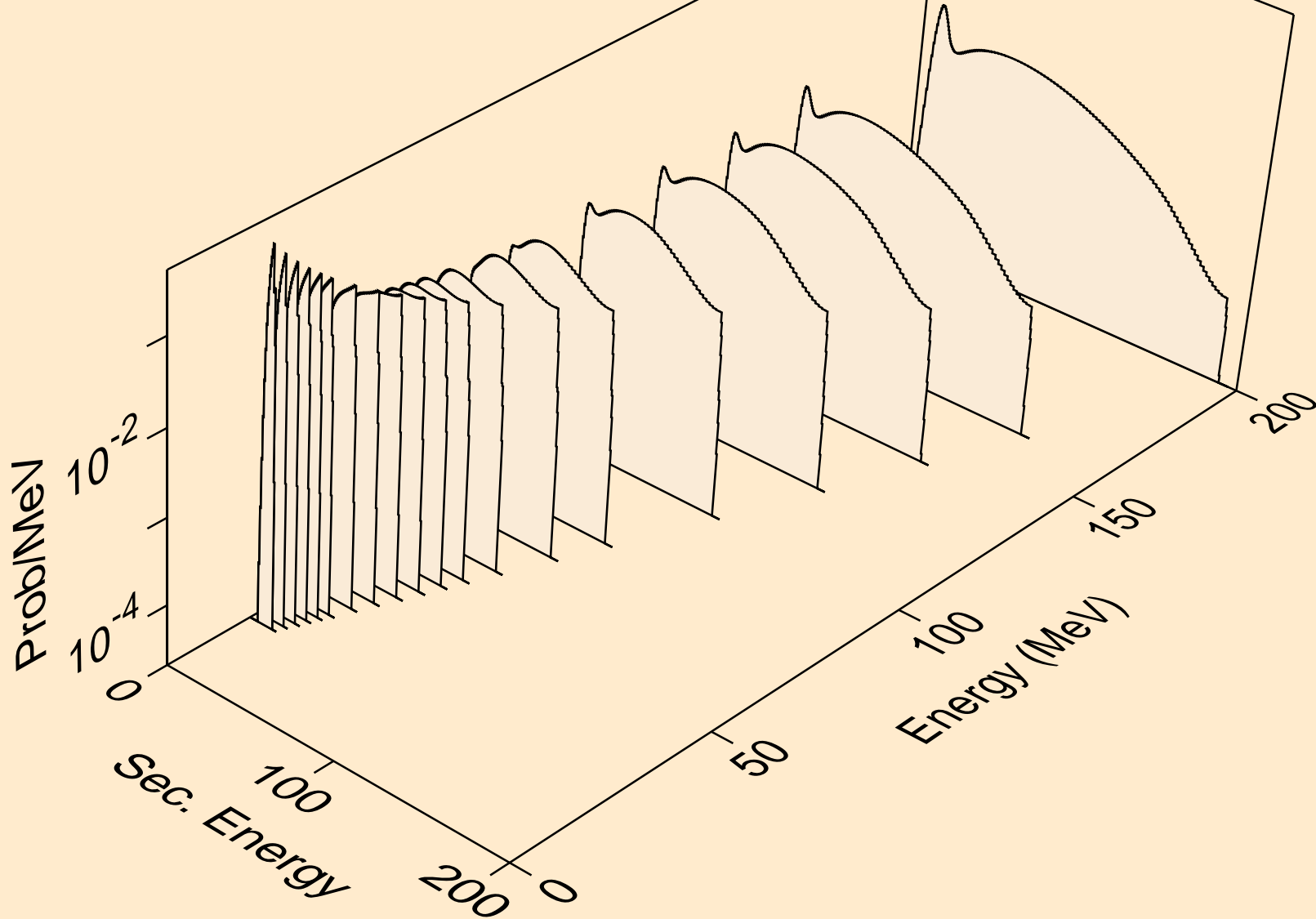

64-GD-160 FOR FENDL-3.1 FROM FENDL-3.1 WITH NJOY2012.50  
deuterons from (n,n\*)d

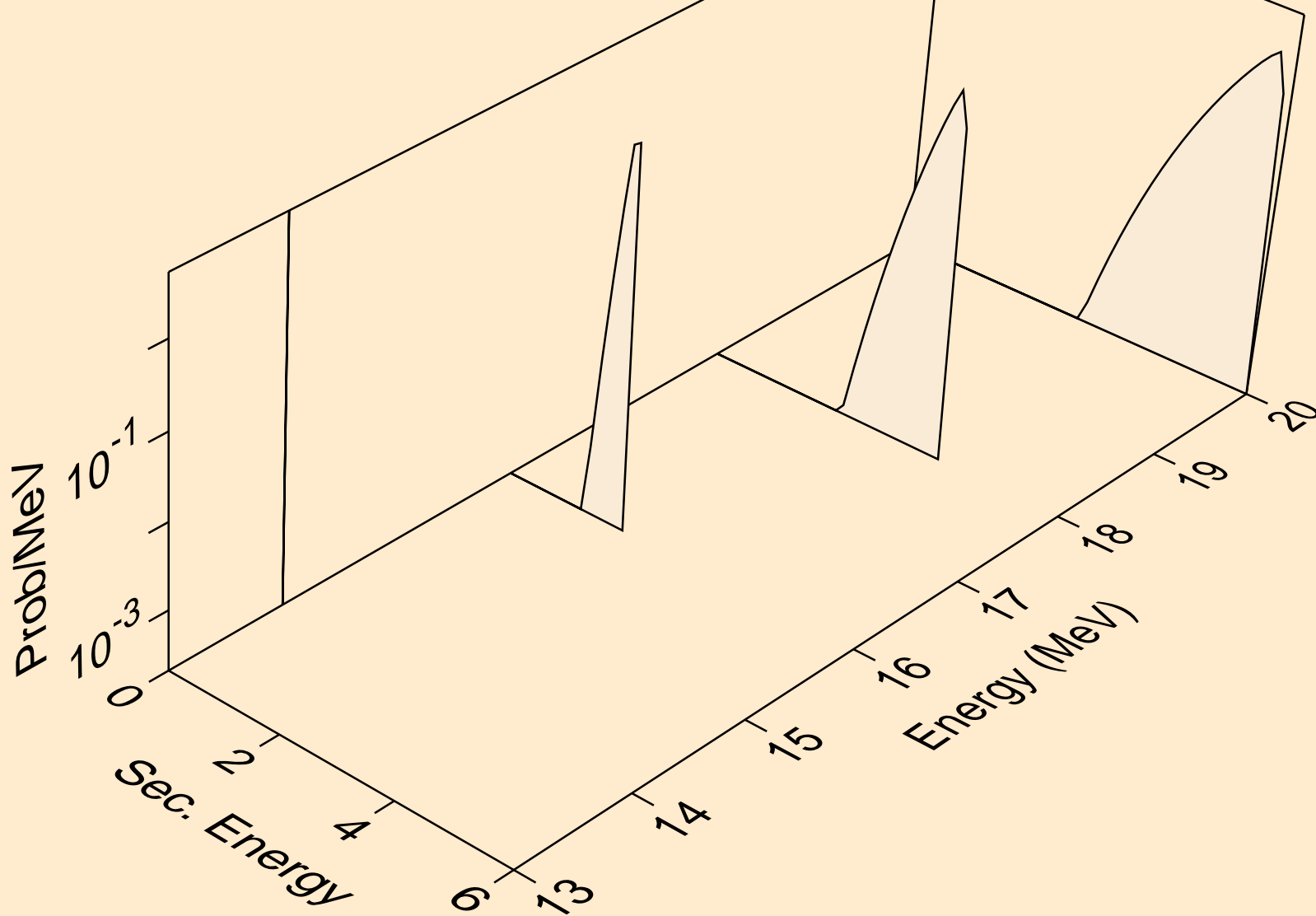

64-GD-160 FOR FENDL-3.1 FROM FENDL-3.1 WITH NJOY2012.50  
tritons from (n,x)

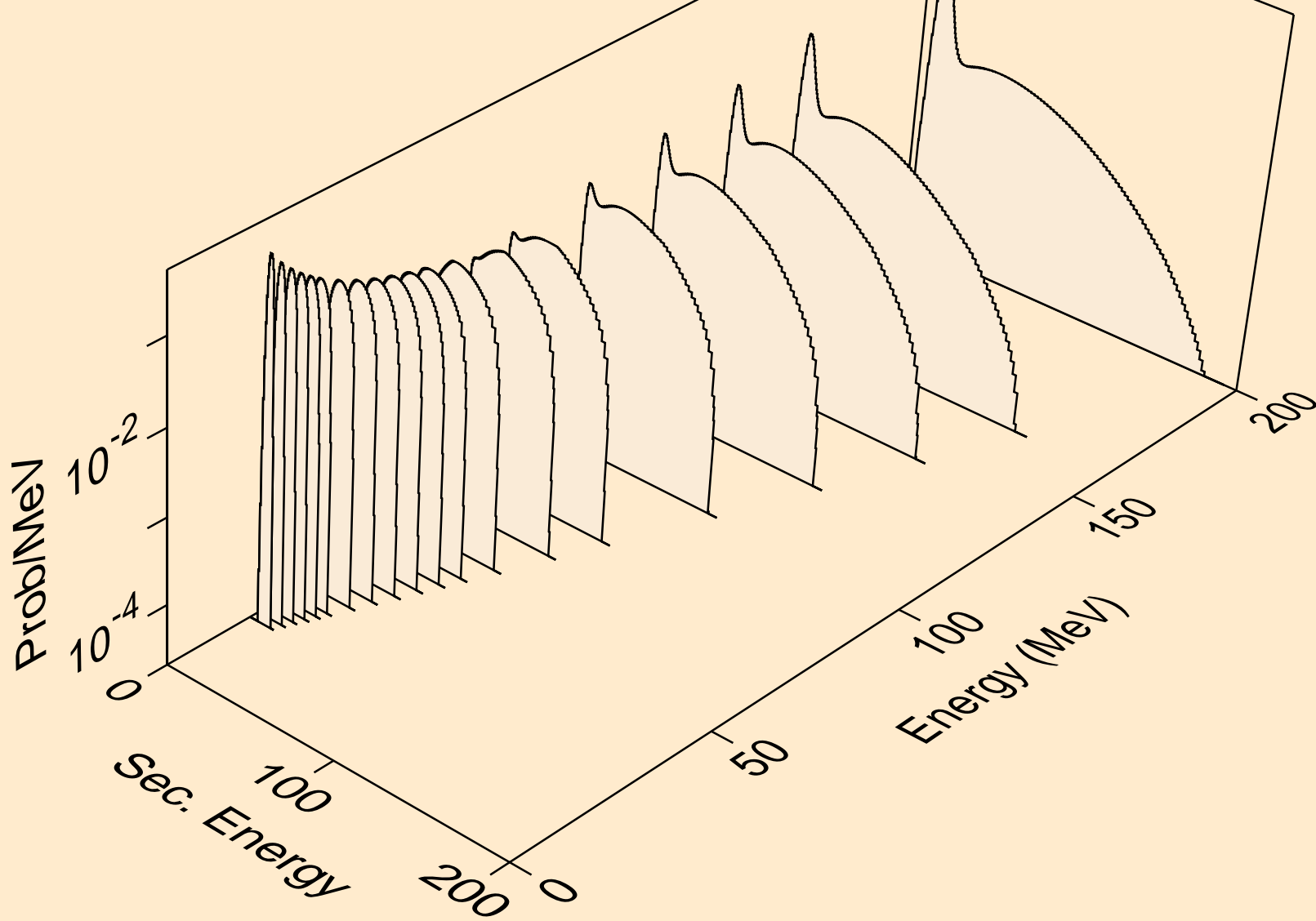



64-GD-160 FOR FENDL-3.1 FROM FENDL-3.1 WITH NJOY2012.50  
tritons from (n,n\*)t

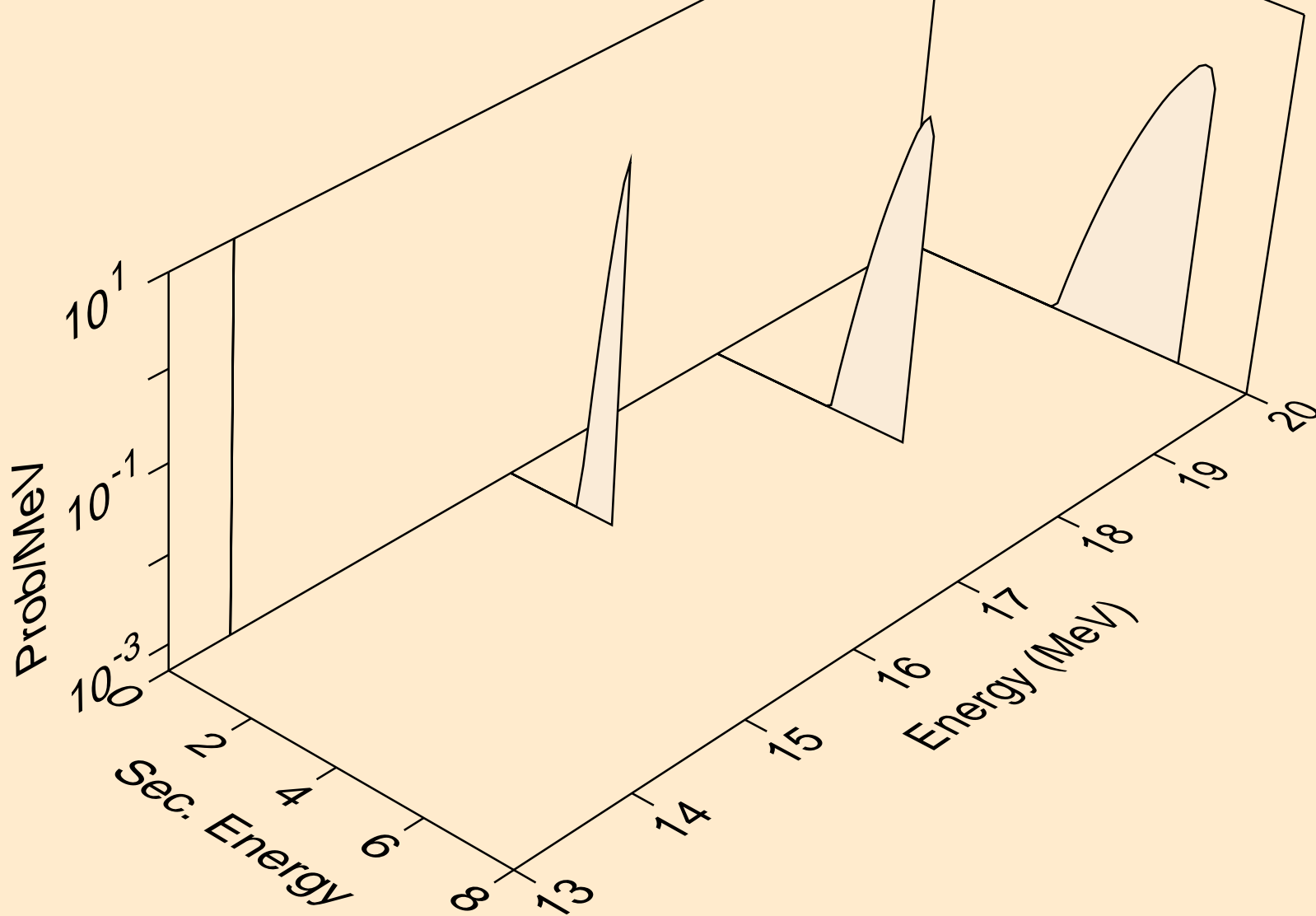

64-GD-160 FOR FENDL-3.1 FROM FENDL-3.1 WITH NJOY2012.50  
he3s from (n,x)

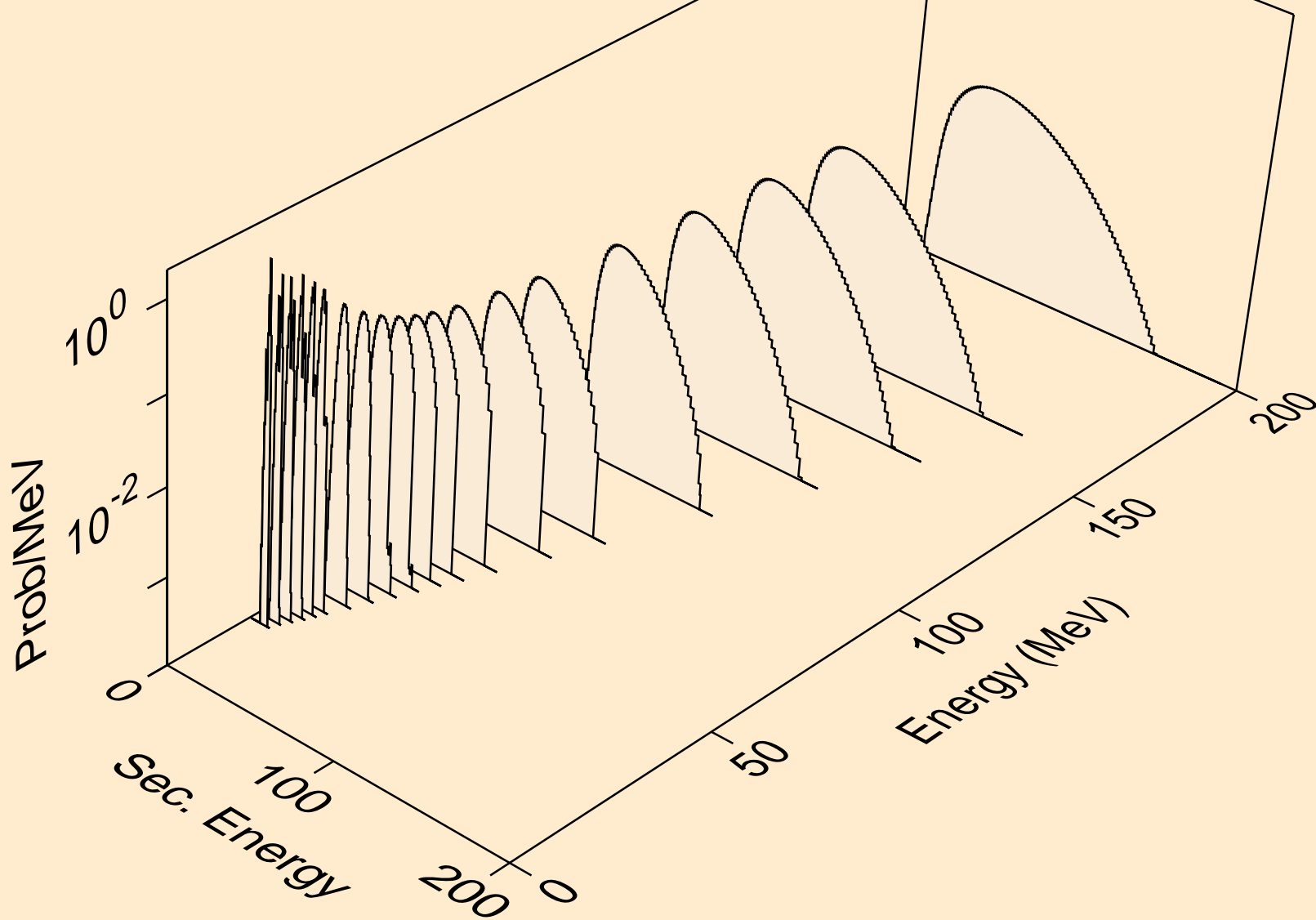

64-GD-160 FOR FENDL-3.1 FROM FENDL-3.1 WITH NJOY2012.50  
alphas from (n,x)

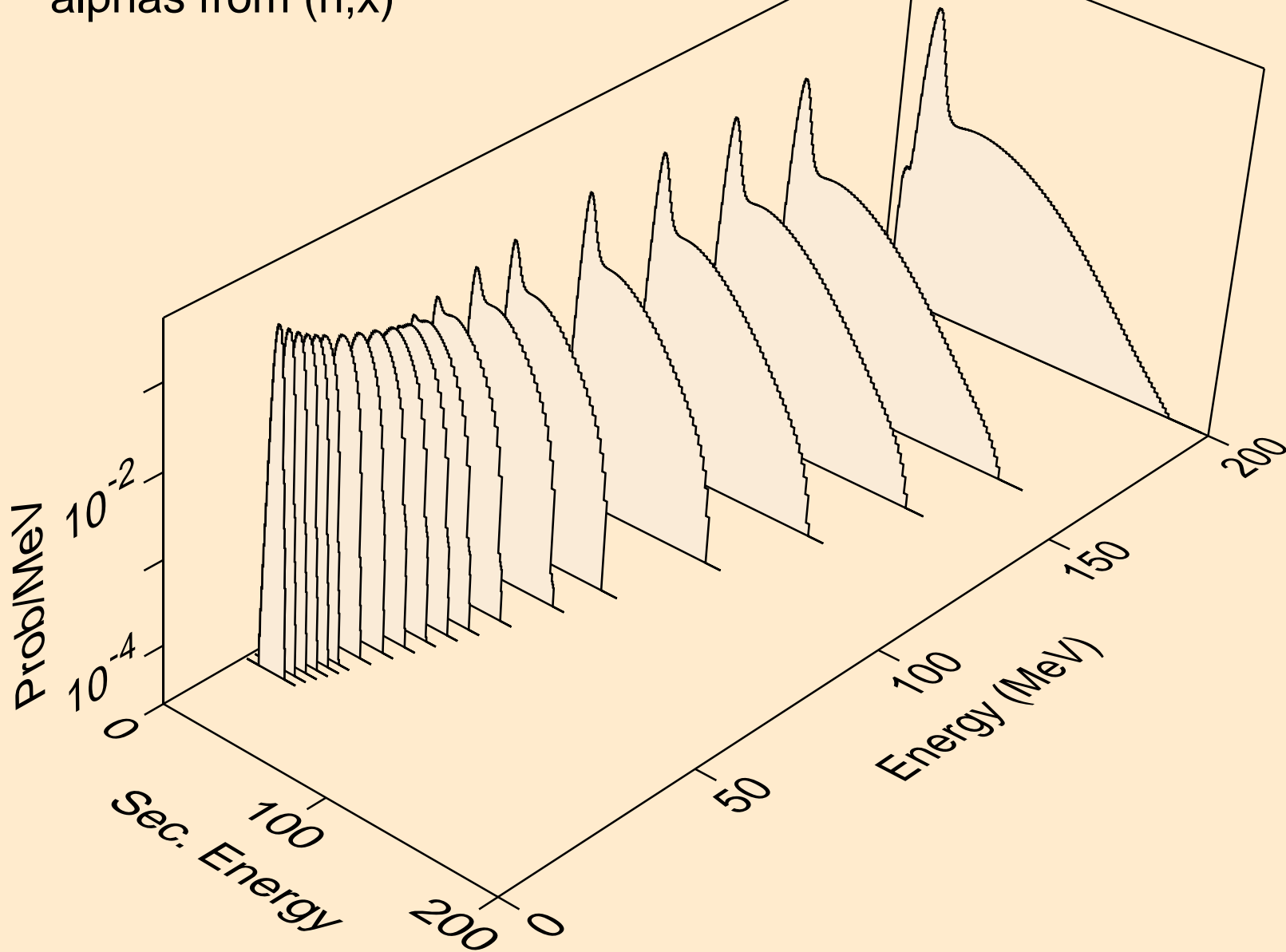

64-GD-160 FOR FENDL-3.1 FROM FENDL-3.1 WITH NJOY2012.50  
alphas from (n,n\*)a

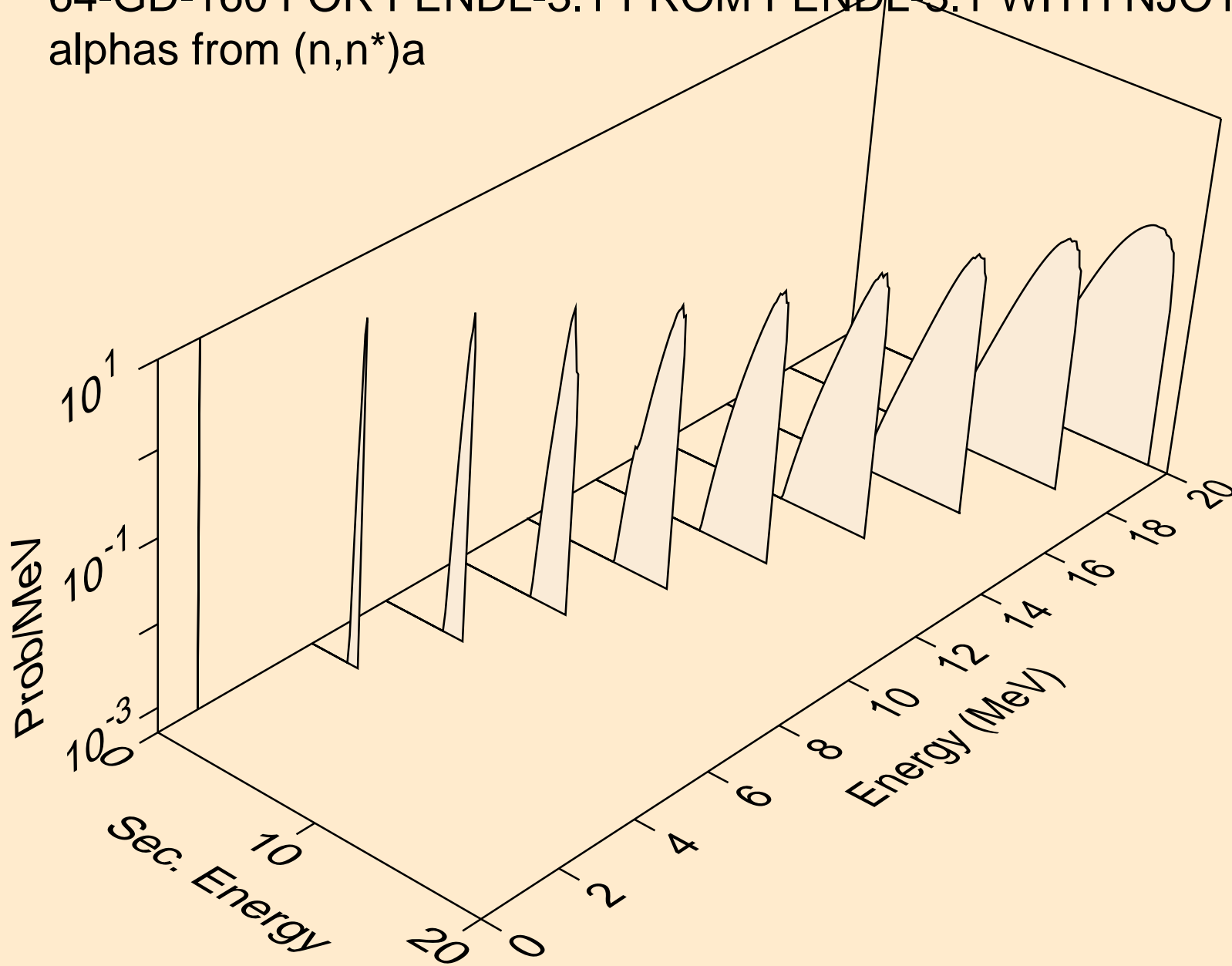

64-GD-160 FOR FENDL-3.1 FROM FENDL-3.1 WITH NJOY2012.50  
alphas from (n,2n)a

