

68-ER-166 FOR FENDL-3.1 FROM FENDL-3.1 WITH NJOY2012.50
Principal cross sections

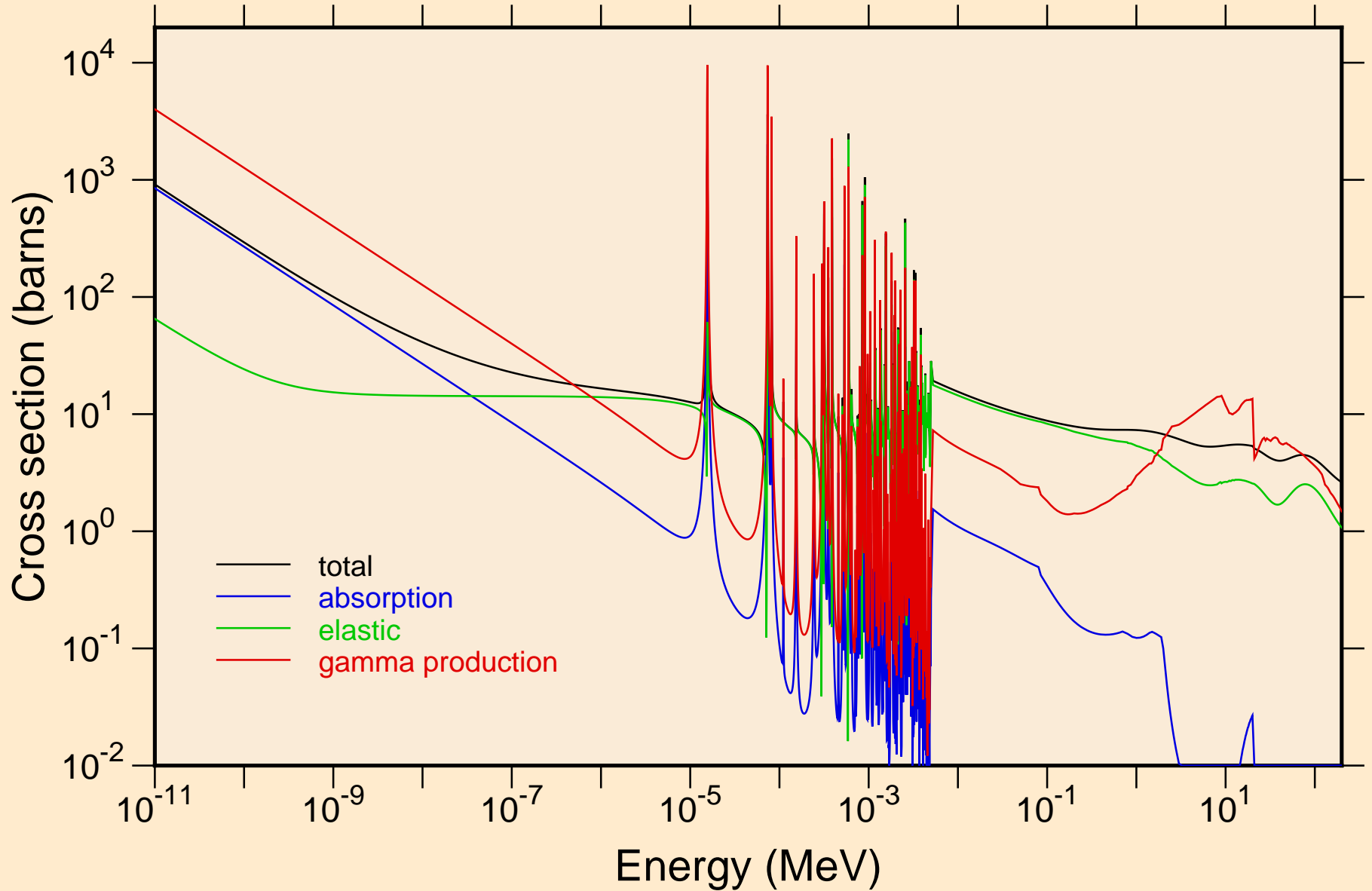

68-ER-166 FOR FENDL-3.1 FROM FENDL-3.1 WITH NJOY2012.50
resonance total cross section

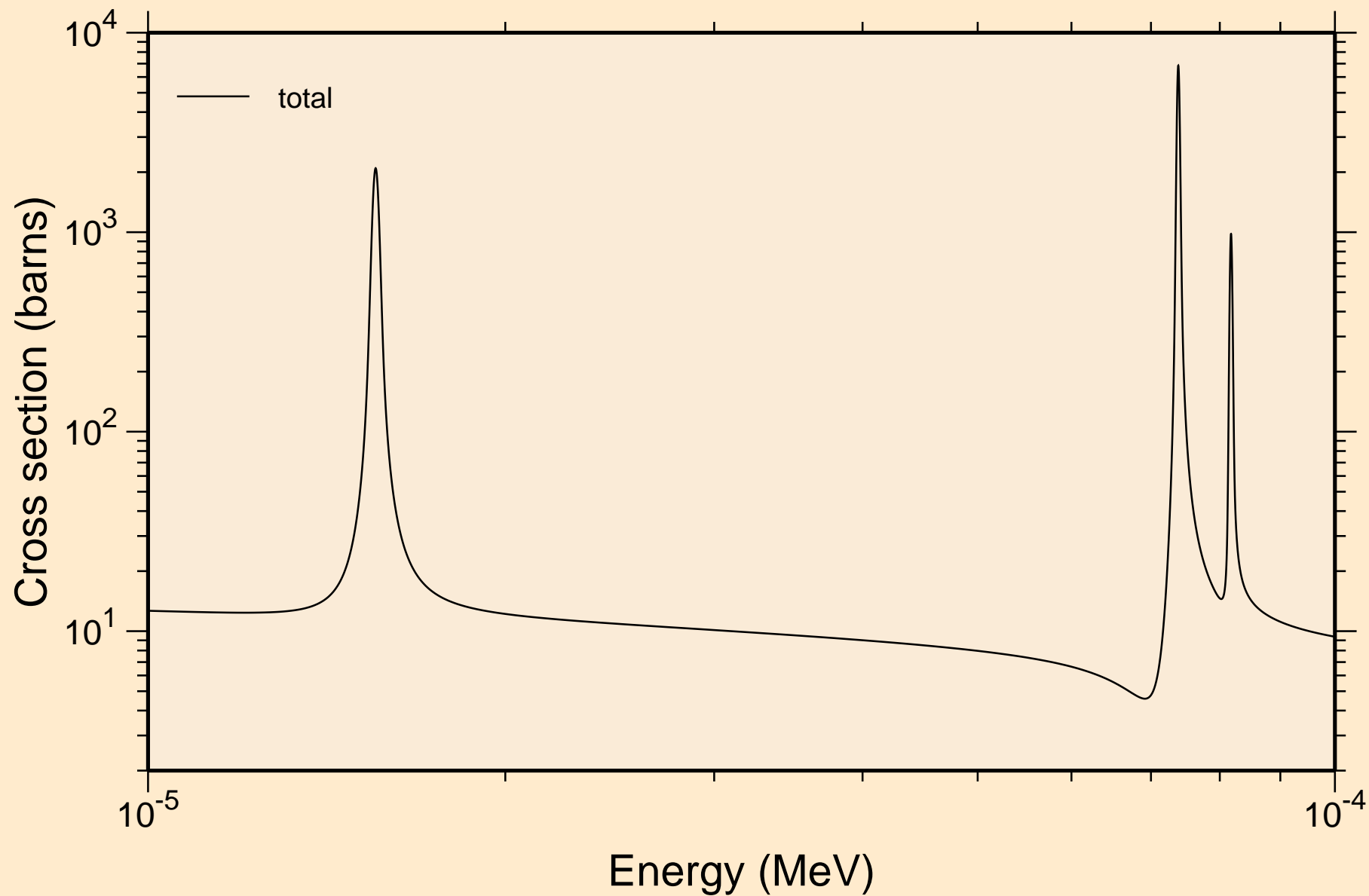

68-ER-166 FOR FENDL-3.1 FROM FENDL-3.1 WITH NJOY2012.50
resonance total cross section

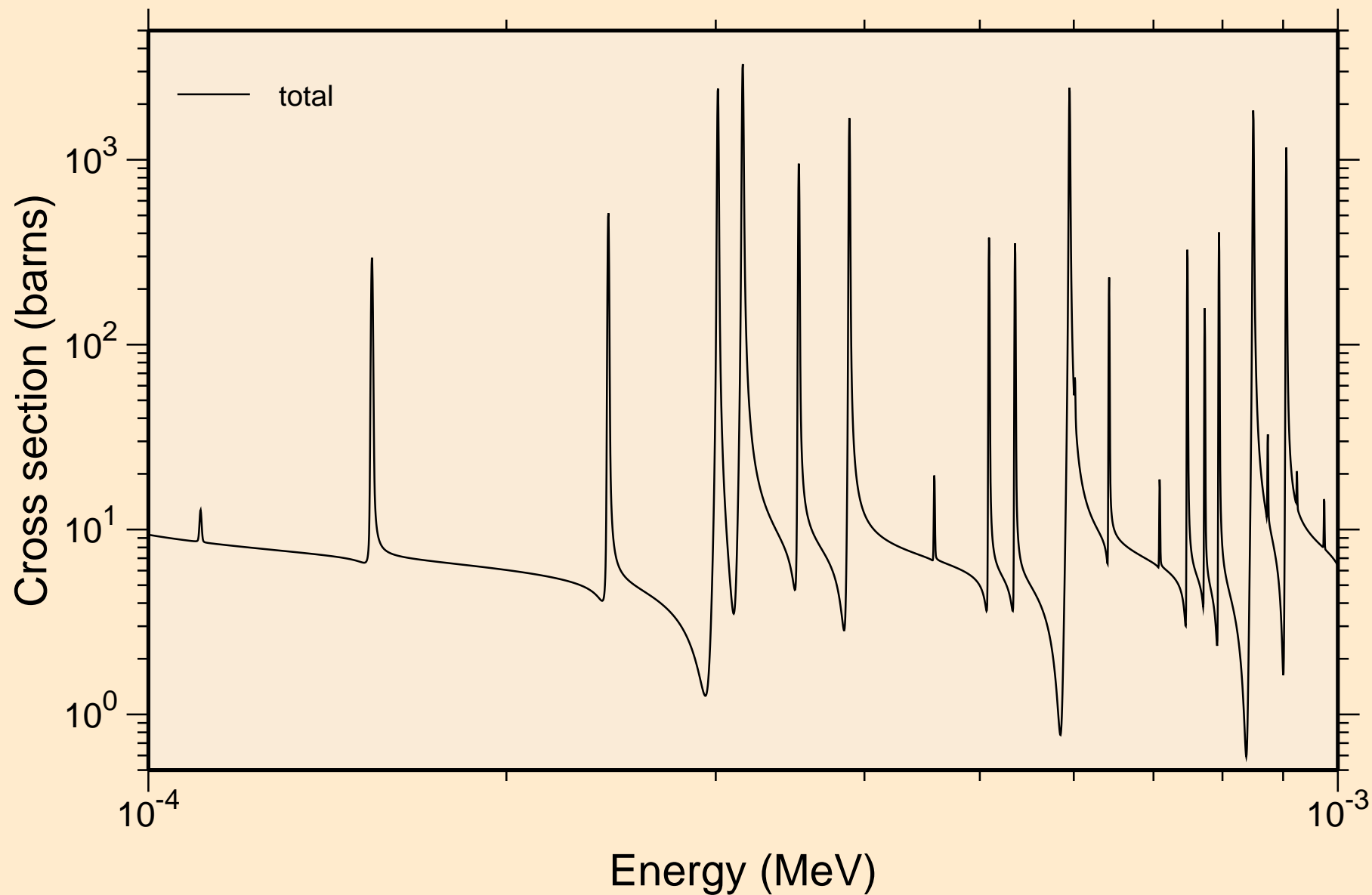

68-ER-166 FOR FENDL-3.1 FROM FENDL-3.1 WITH NJOY2012.50
resonance total cross section

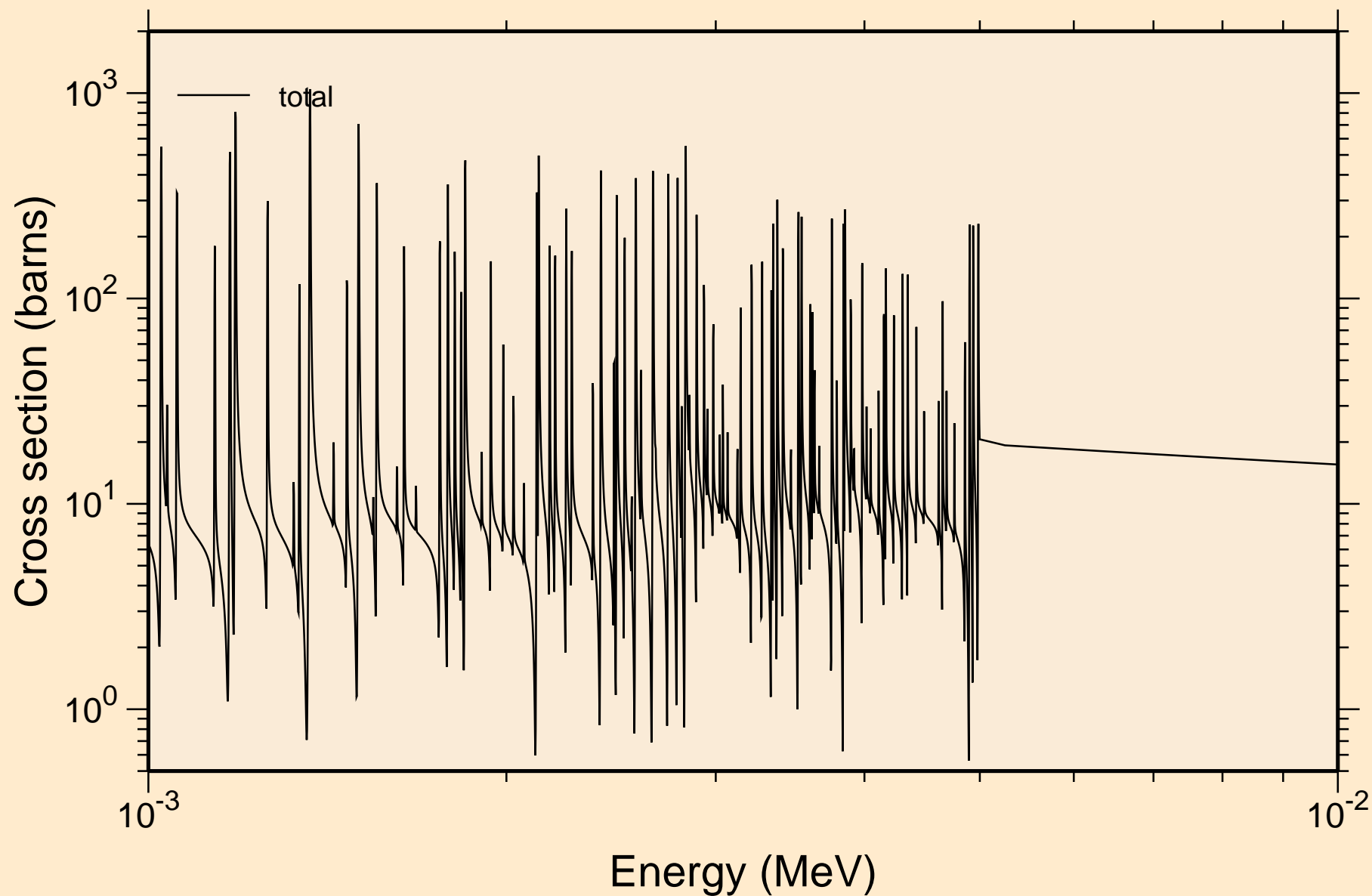

68-ER-166 FOR FENDL-3.1 FROM FENDL-3.1 WITH NJOY2012.50
resonance total cross section

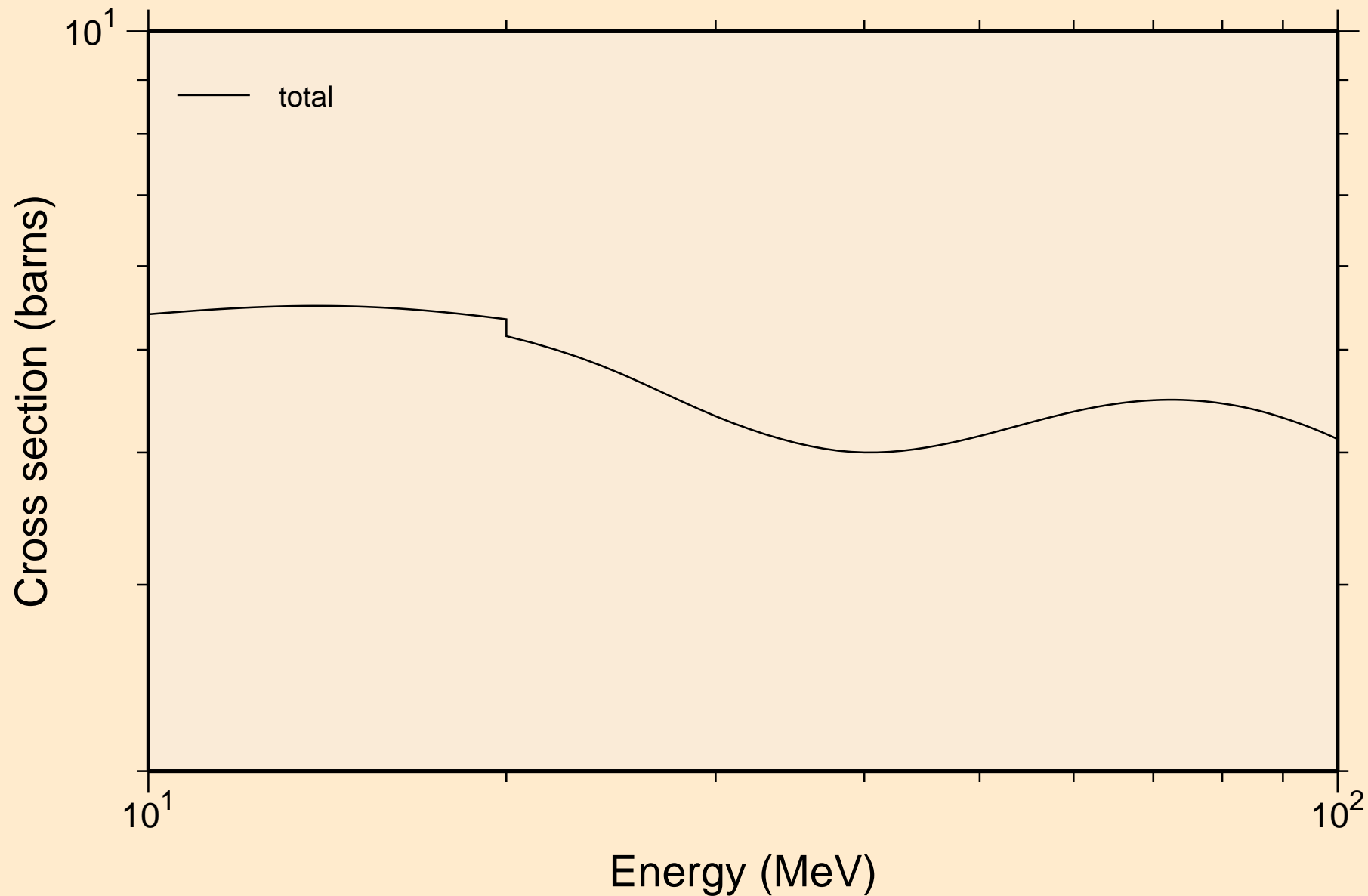

68-ER-166 FOR FENDL-3.1 FROM FENDL-3.1 WITH NJOY2012.50
resonance absorption cross sections

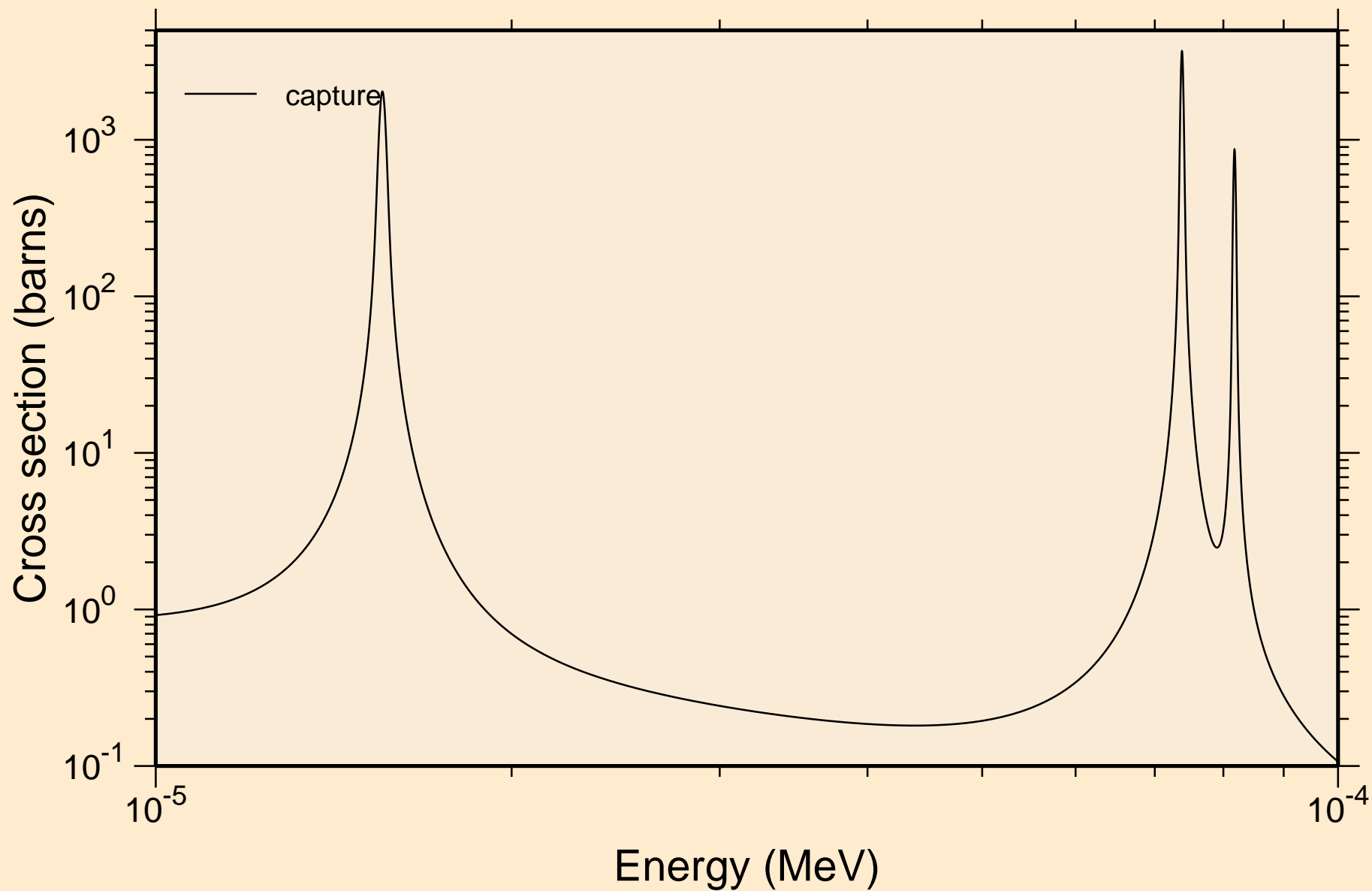

68-ER-166 FOR FENDL-3.1 FROM FENDL-3.1 WITH NJOY2012.50
resonance absorption cross sections

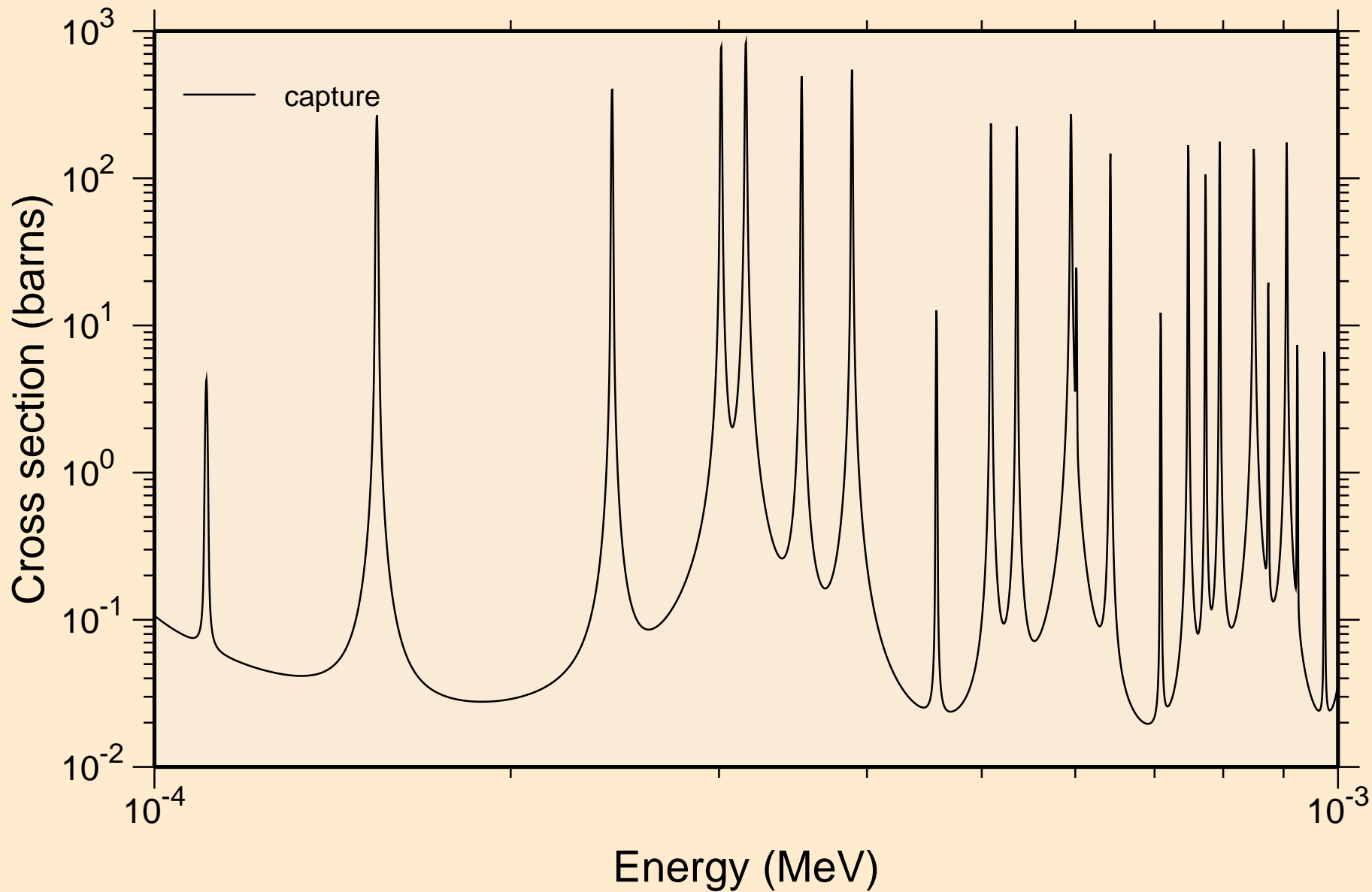

68-ER-166 FOR FENDL-3.1 FROM FENDL-3.1 WITH NJOY2012.50
resonance absorption cross sections

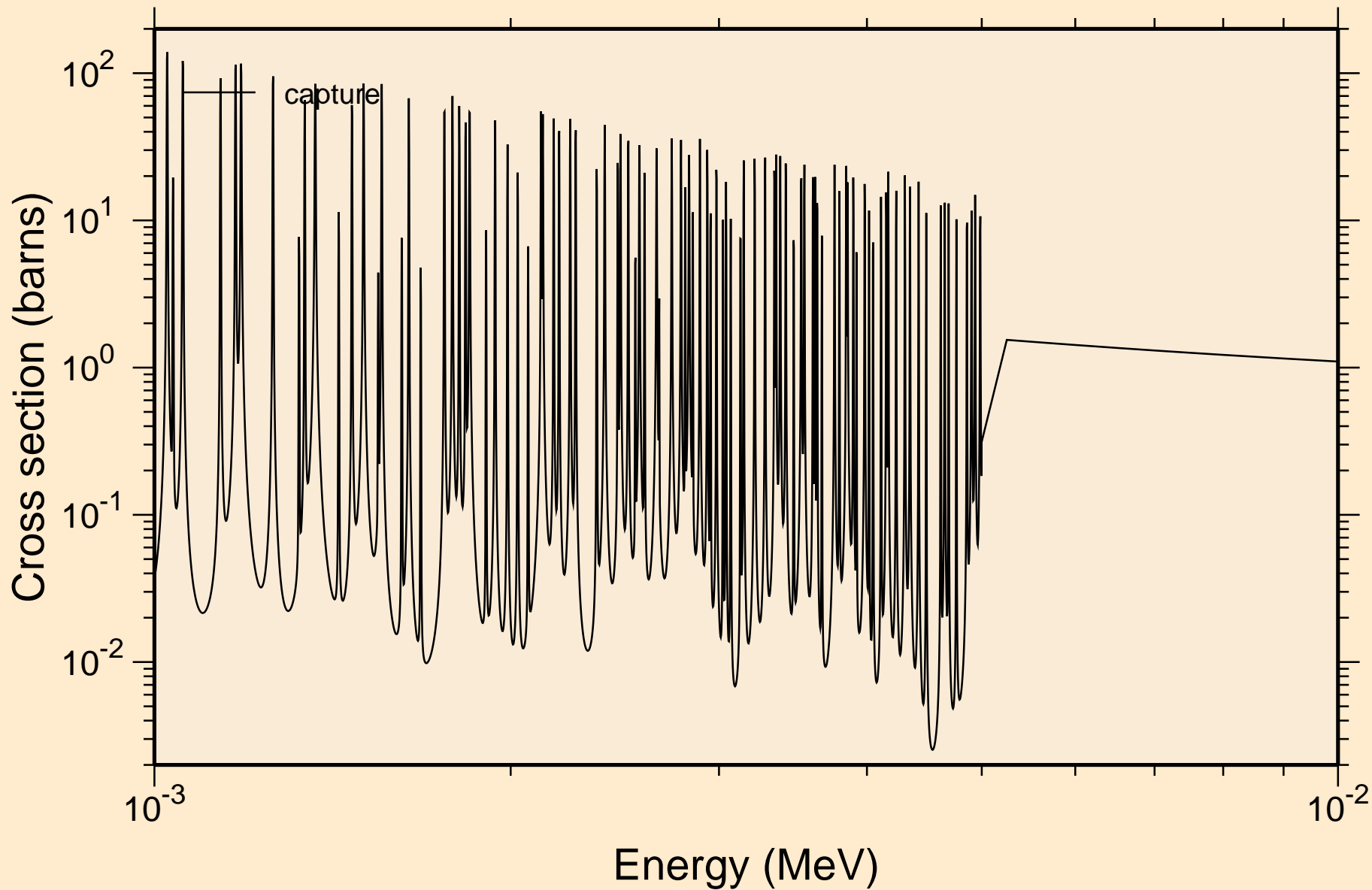

68-ER-166 FOR FENDL-3.1 FROM FENDL-3.1 WITH NJOY2012.50
resonance absorption cross sections

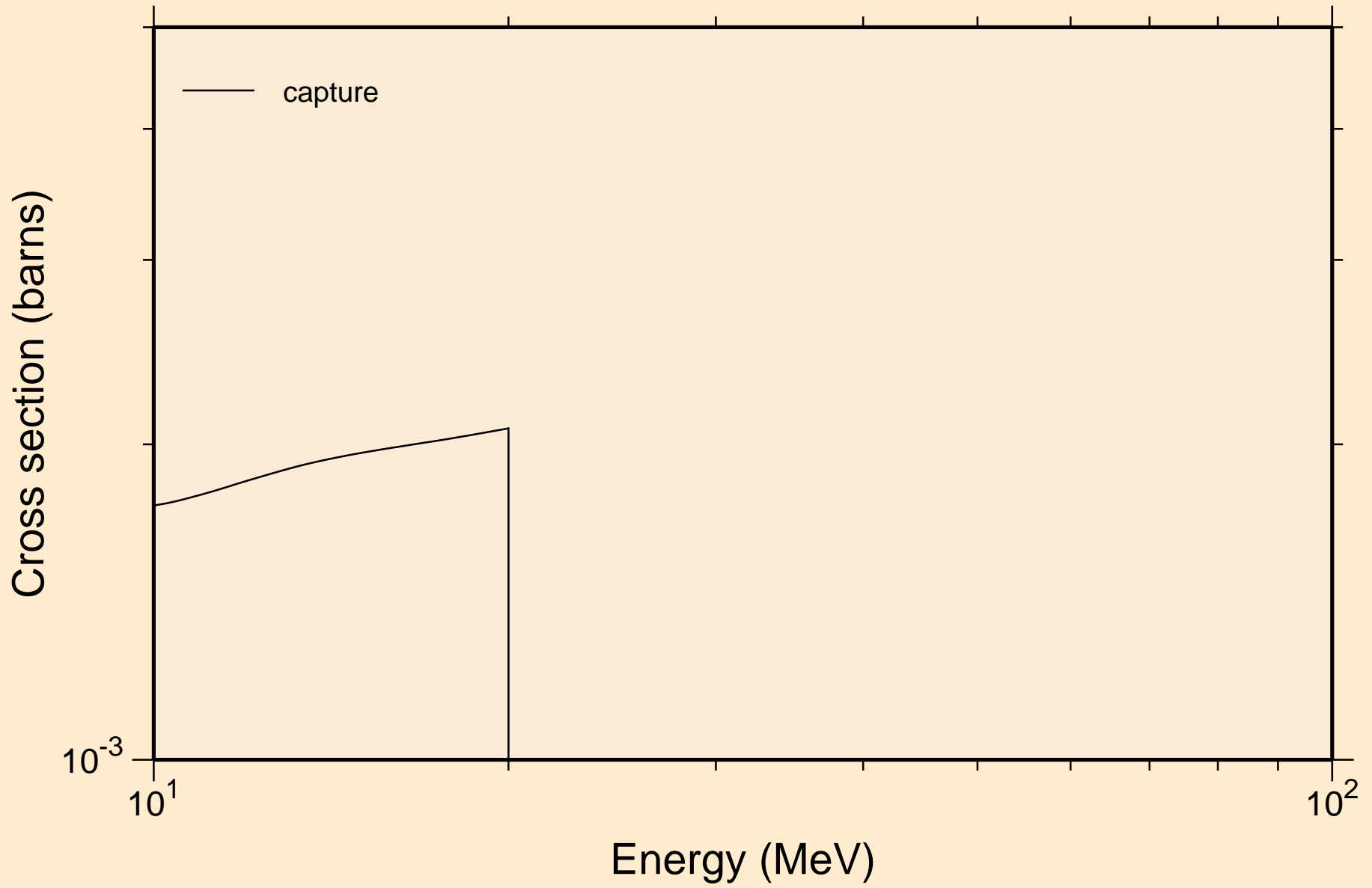

68-ER-166 FOR FENDL-3.1 FROM FENDL-3.1 WITH NJOY2012.50 Heating

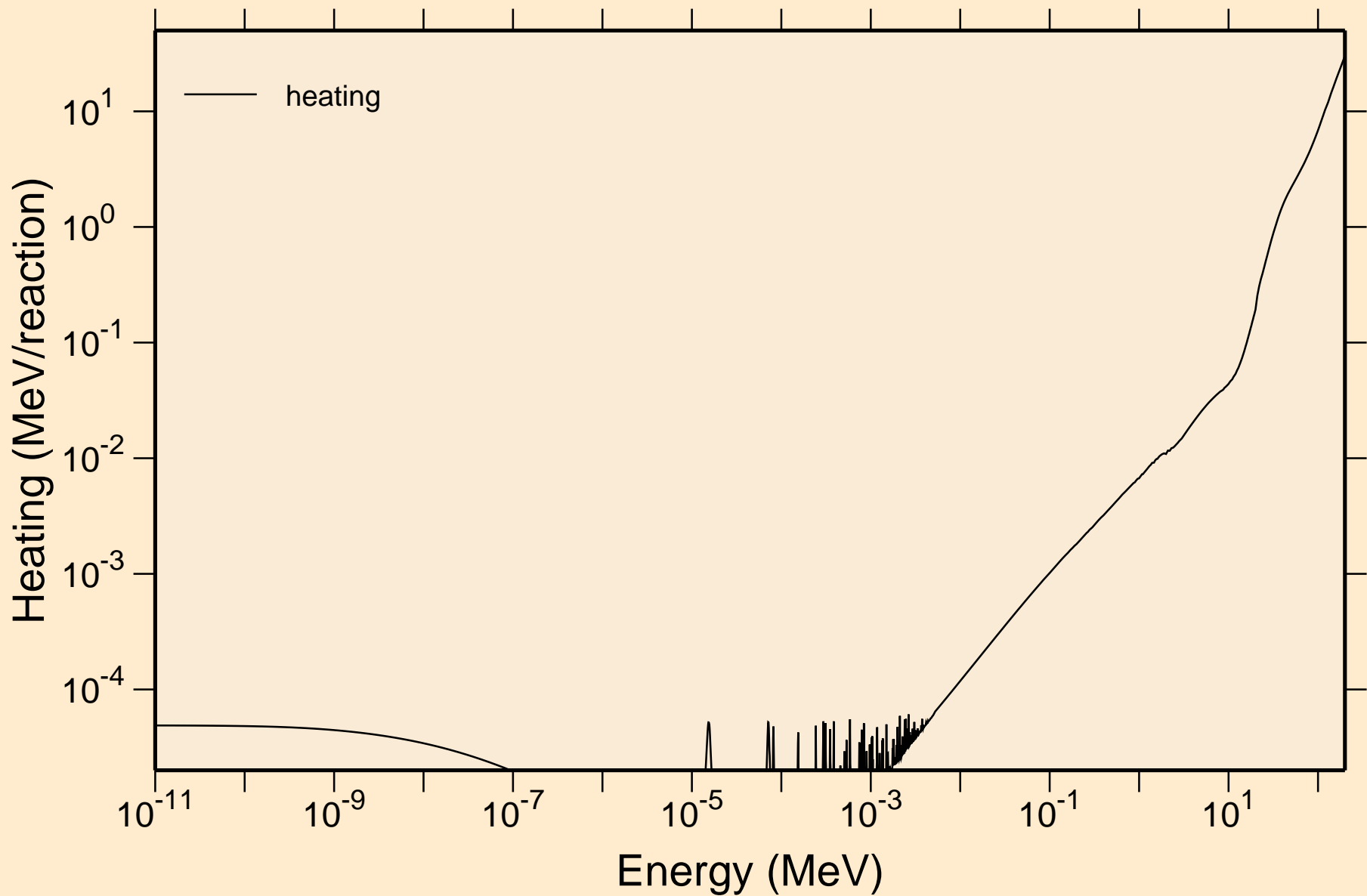

68-ER-166 FOR FENDL-3.1 FROM FENDL-3.1 WITH NJOY2012.50 Damage

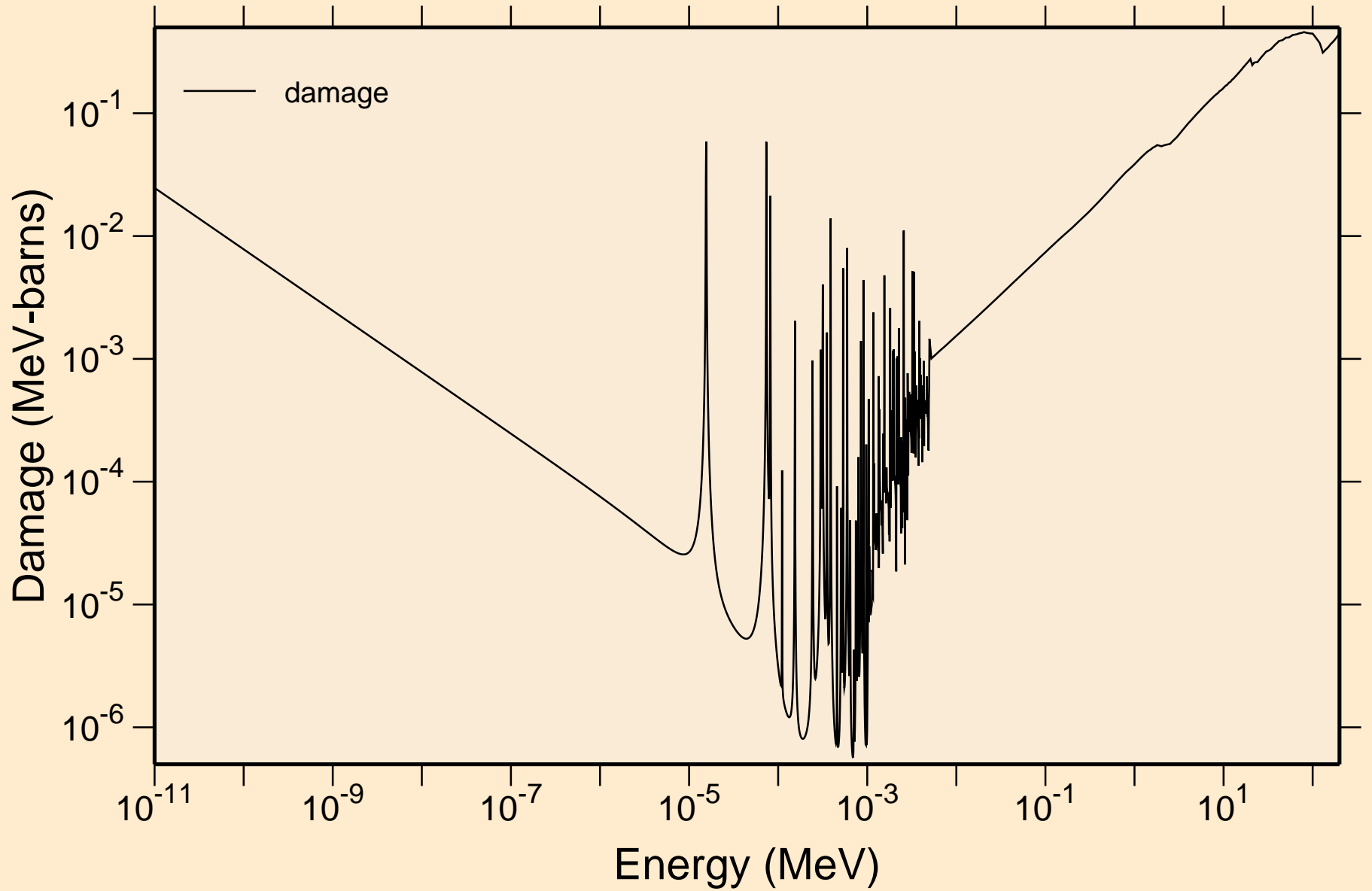

68-ER-166 FOR FENDL-3.1 FROM FENDL-3.1 WITH NJOY2012.50
Non-threshold reactions

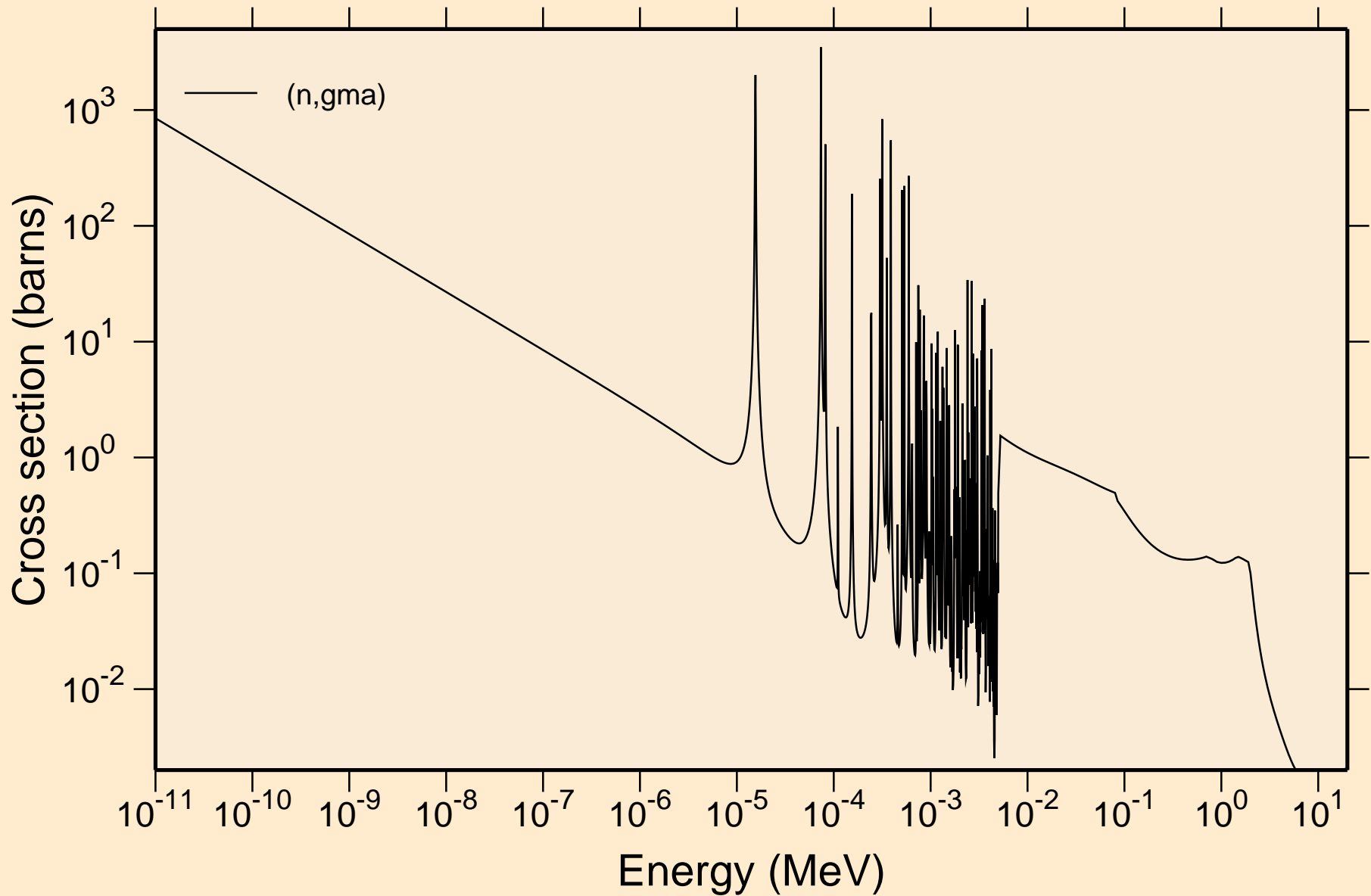

68-ER-166 FOR FENDL-3.1 FROM FENDL-3.1 WITH NJOY2012.50
Principal cross sections

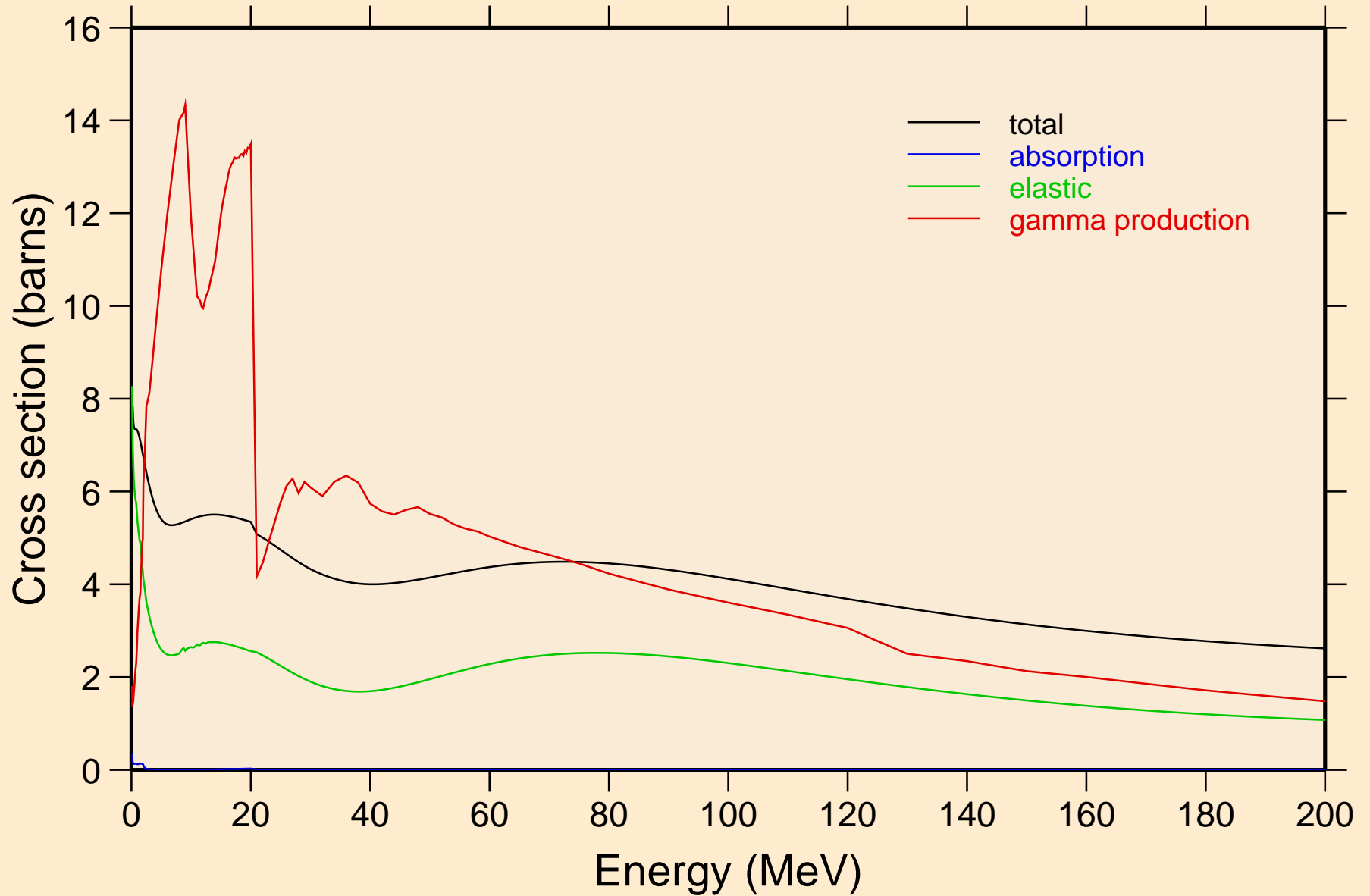

68-ER-166 FOR FENDL-3.1 FROM FENDL-3.1 WITH NJOY2012.50

Heating

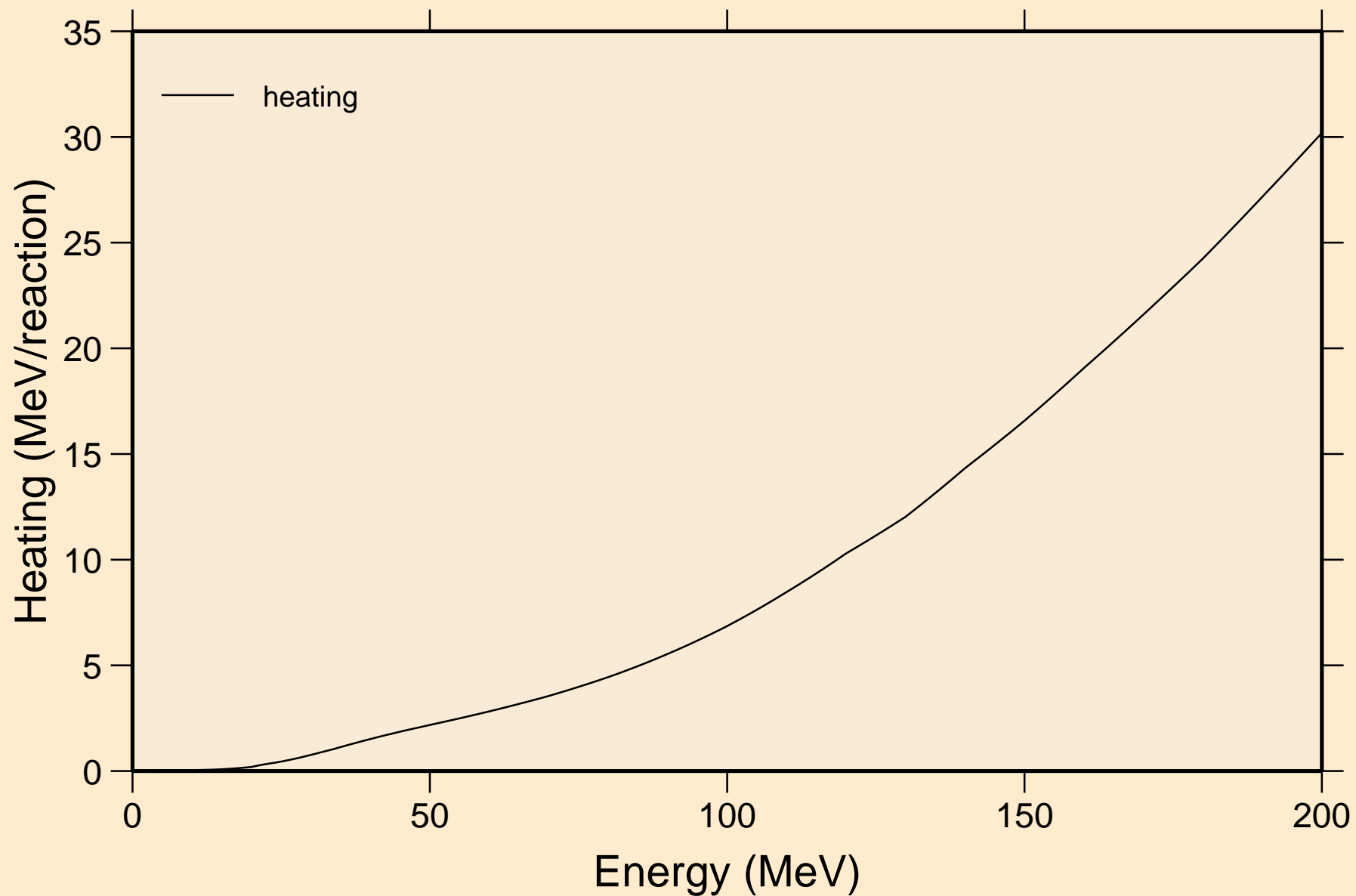

68-ER-166 FOR FENDL-3.1 FROM FENDL-3.1 WITH NJOY2012.50 Damage

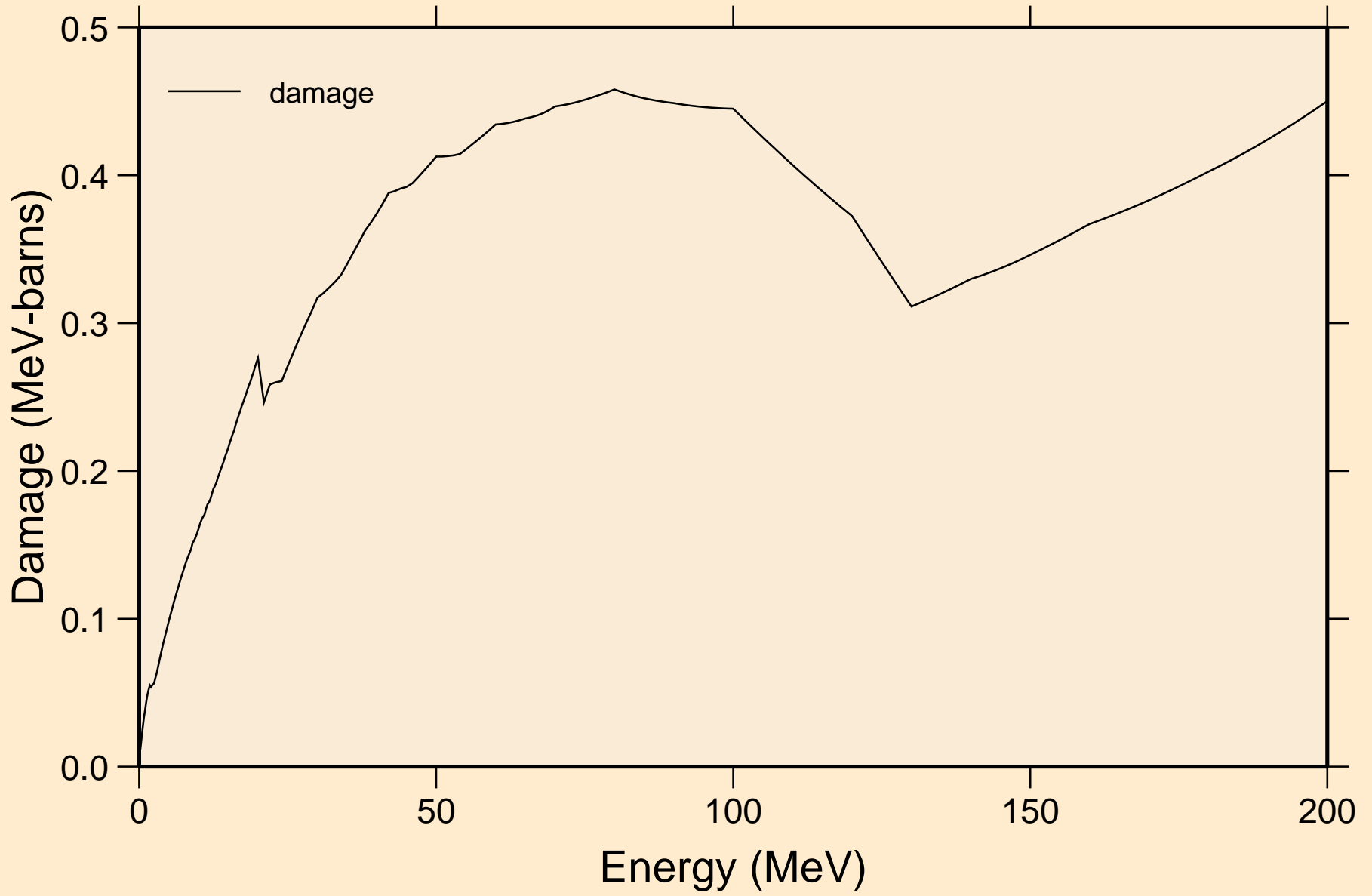

68-ER-166 FOR FENDL-3.1 FROM FENDL-3.1 WITH NJOY2012.50
Non-threshold reactions

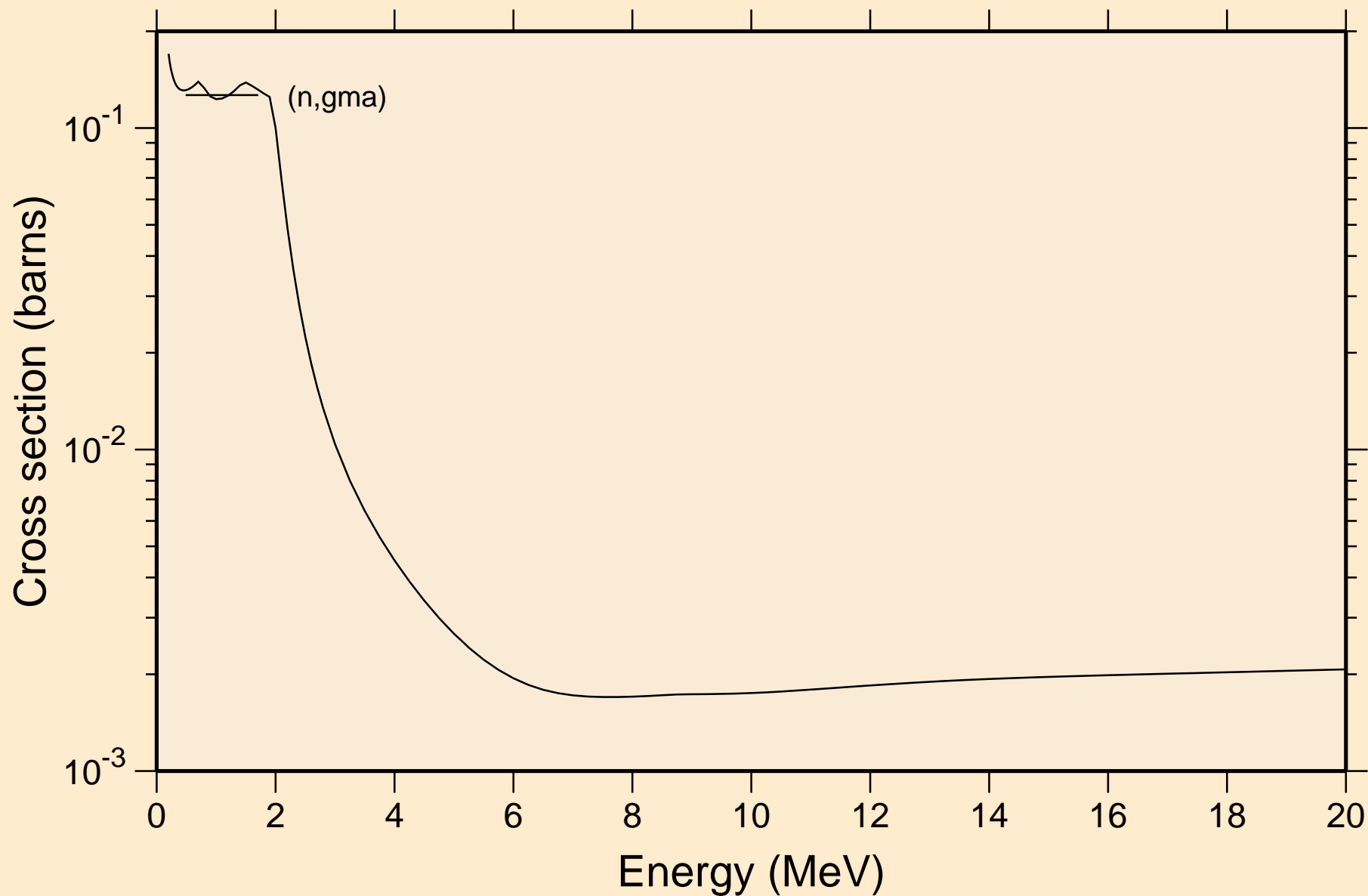

68-ER-166 FOR FENDL-3.1 FROM FENDL-3.1 WITH NJOY2012.50
Inelastic levels

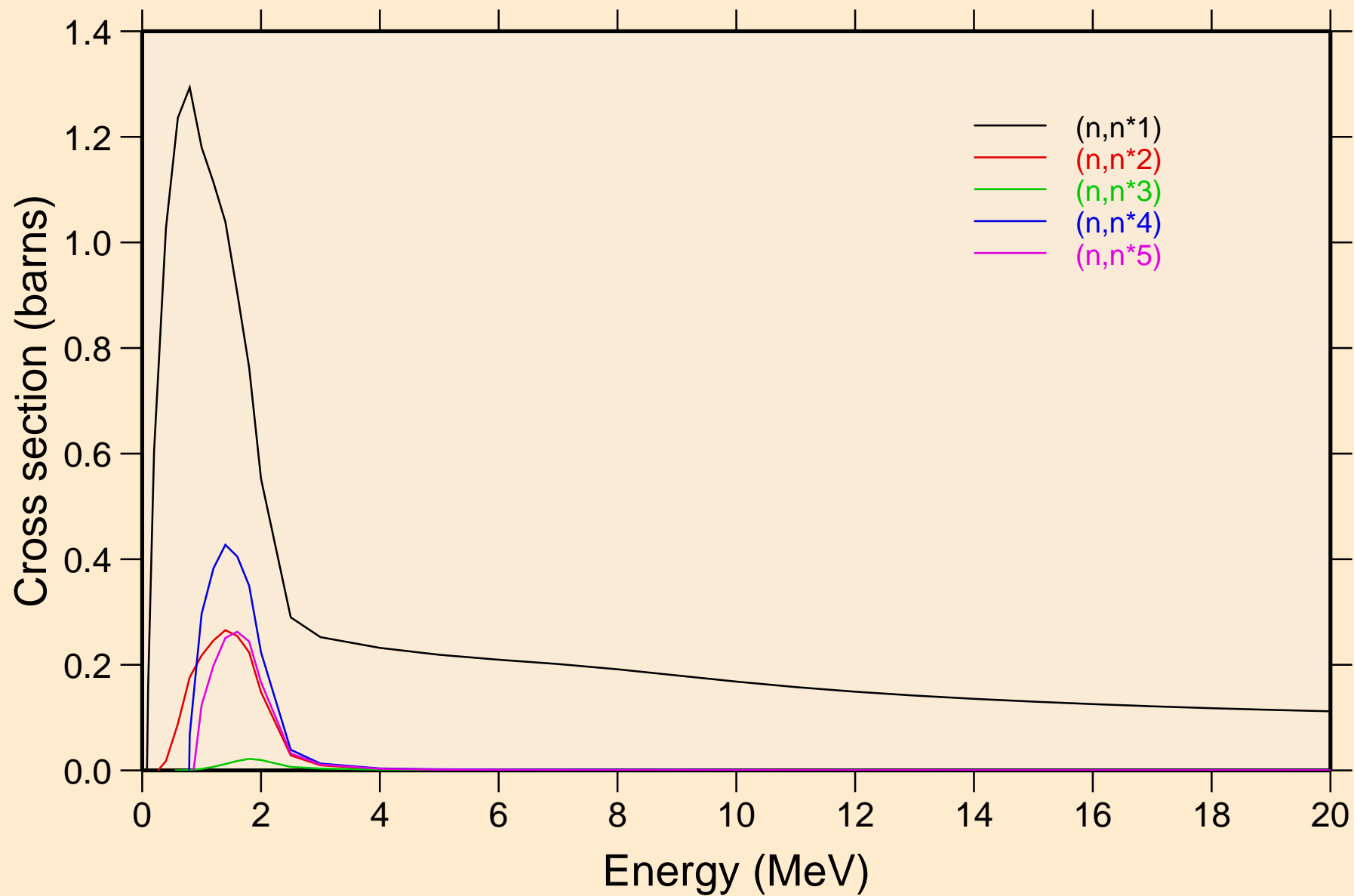

68-ER-166 FOR FENDL-3.1 FROM FENDL-3.1 WITH NJOY2012.50
Inelastic levels

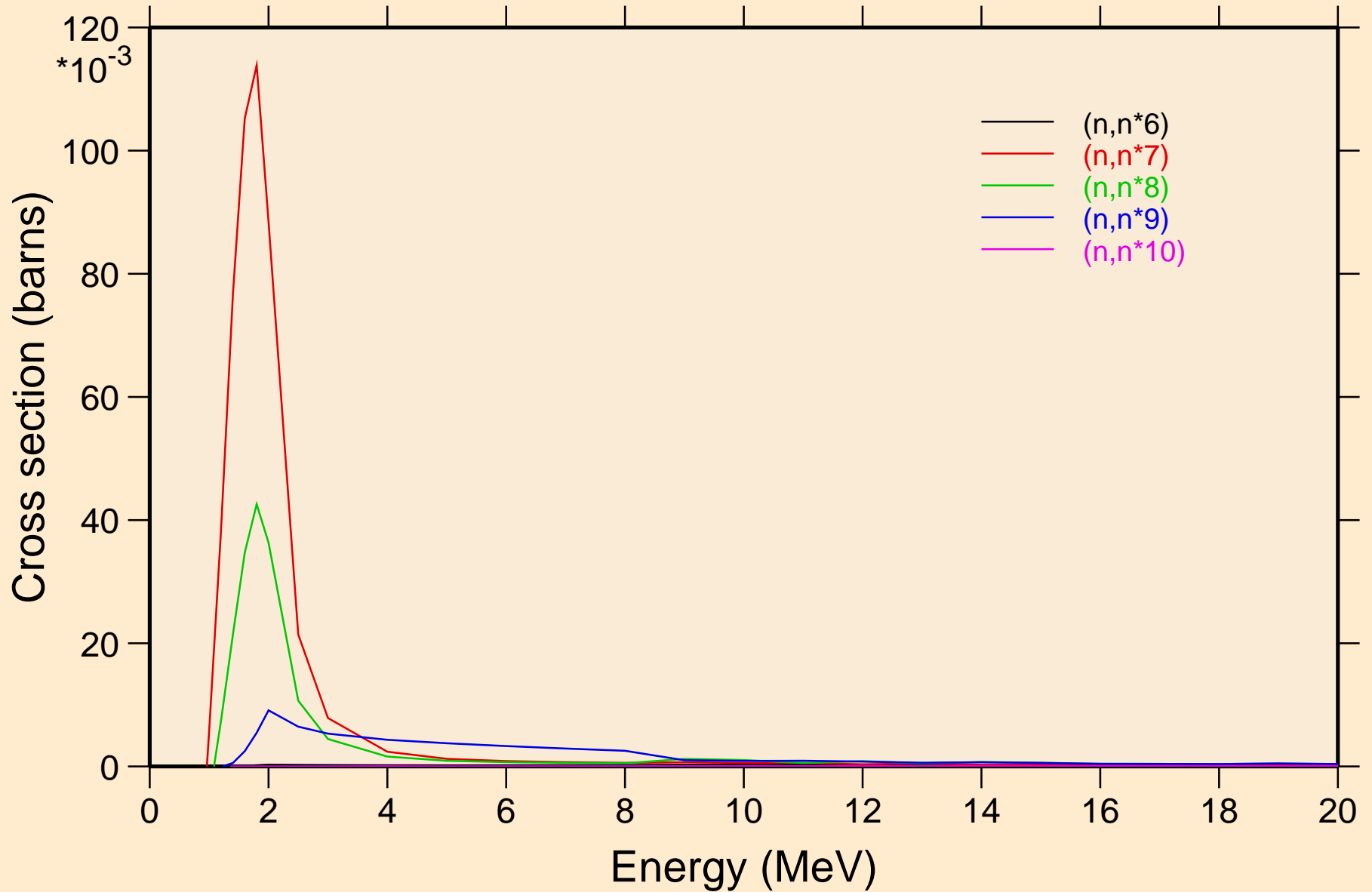

68-ER-166 FOR FENDL-3.1 FROM FENDL-3.1 WITH NJOY2012.50
Inelastic levels

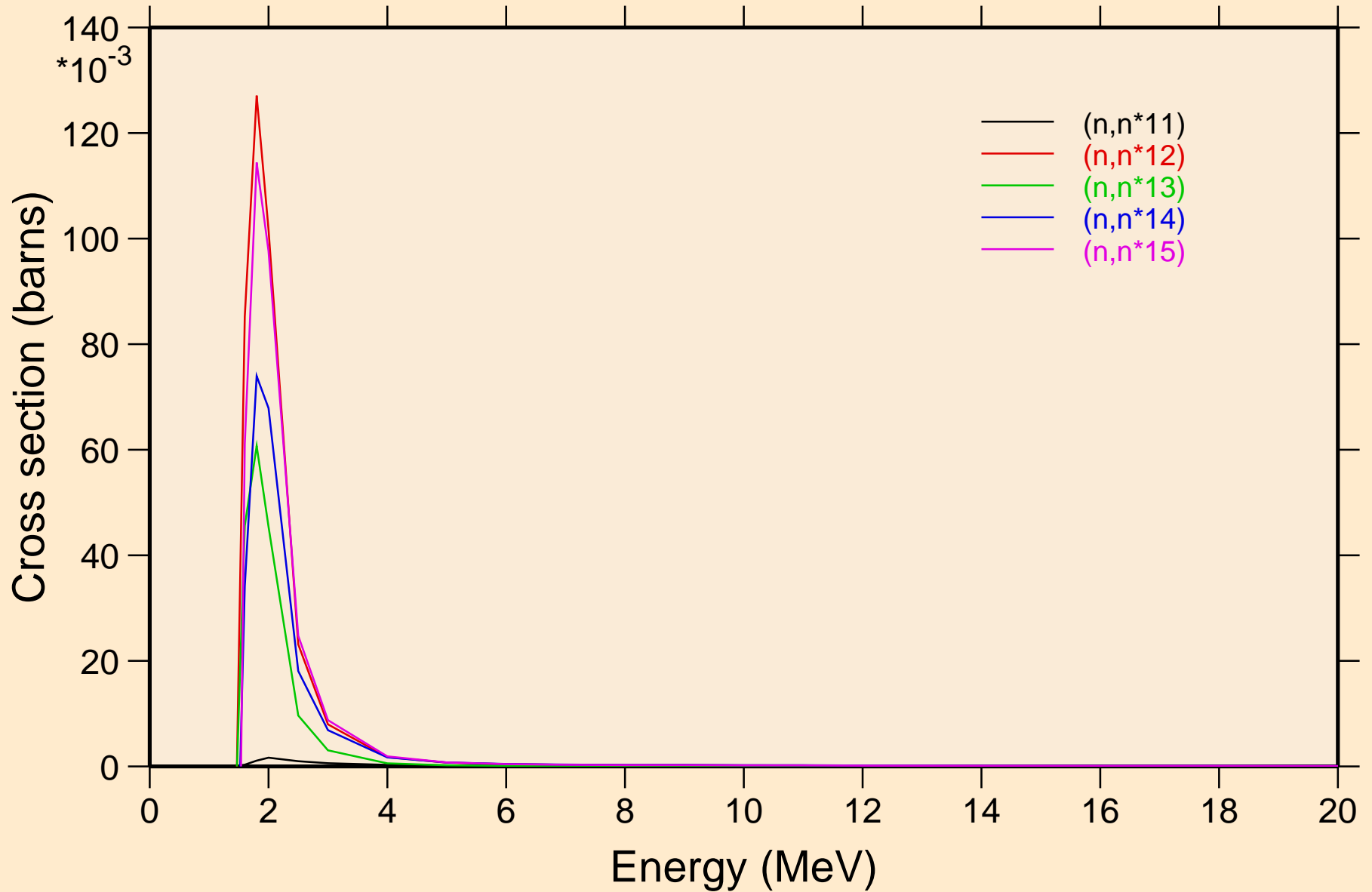

68-ER-166 FOR FENDL-3.1 FROM FENDL-3.1 WITH NJOY2012.50
Inelastic levels

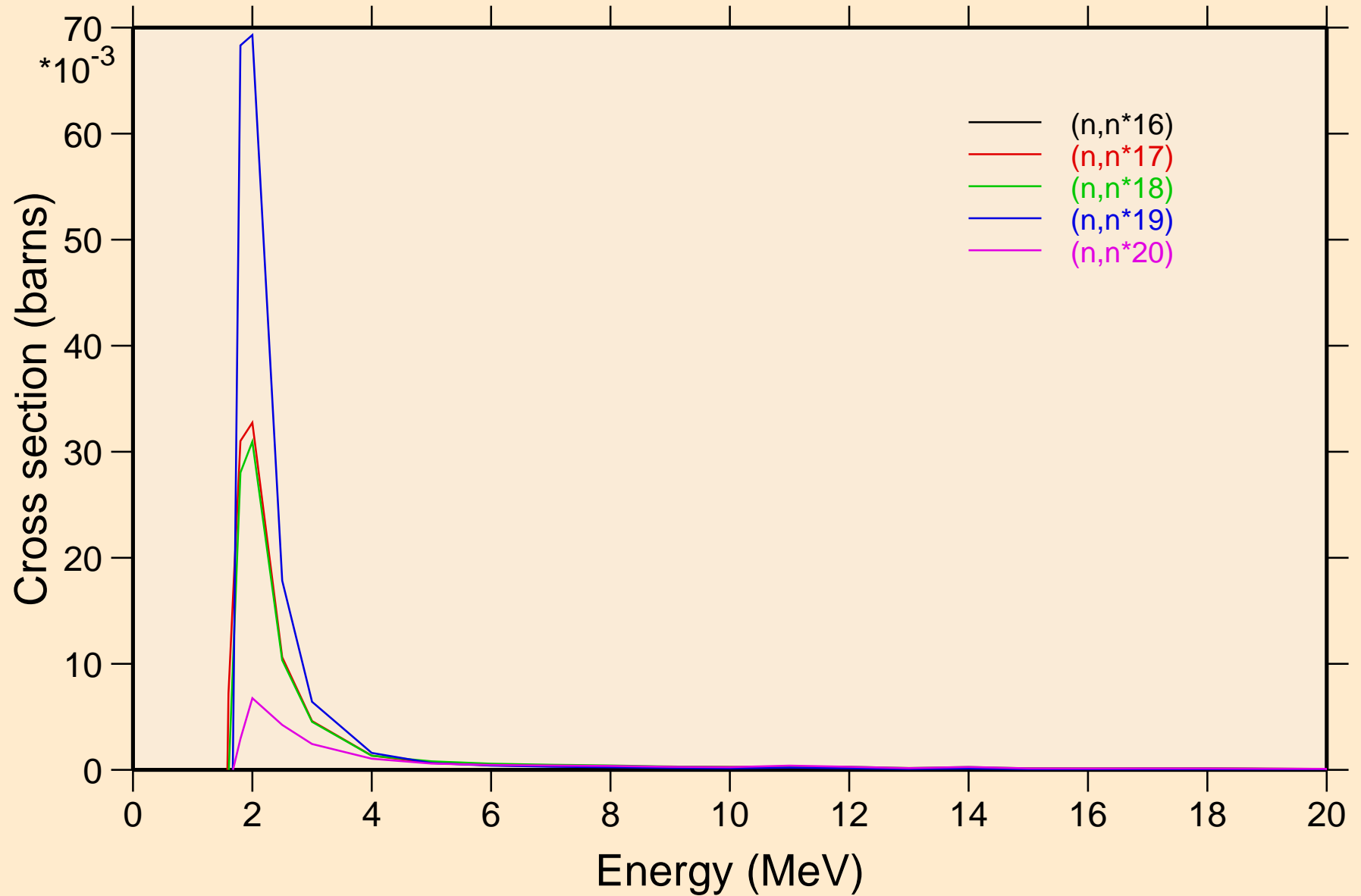

68-ER-166 FOR FENDL-3.1 FROM FENDL-3.1 WITH NJOY2012.50
Inelastic levels

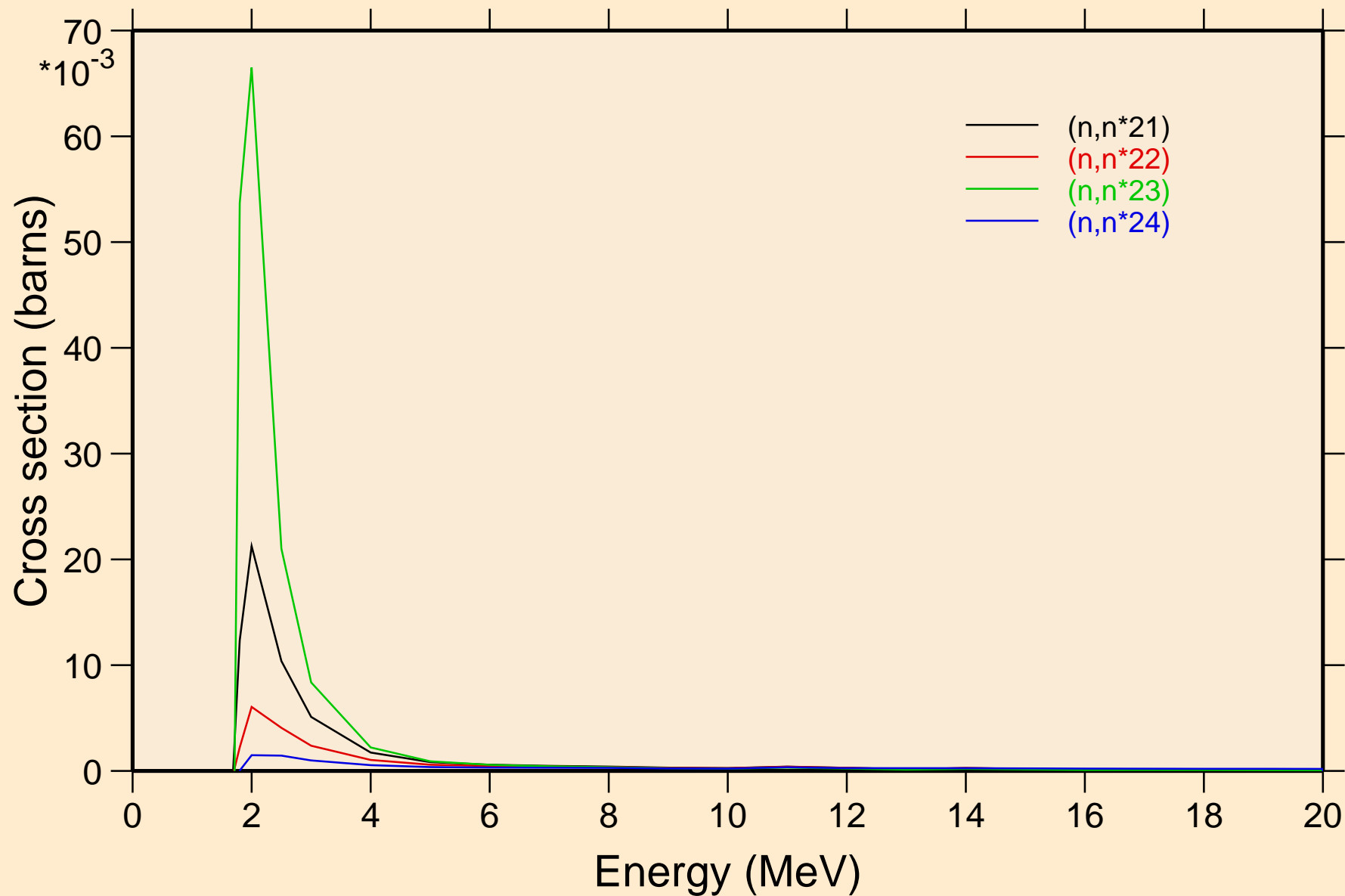

68-ER-166 FOR FENDL-3.1 FROM FENDL-3.1 WITH NJOY2012.50
Threshold reactions

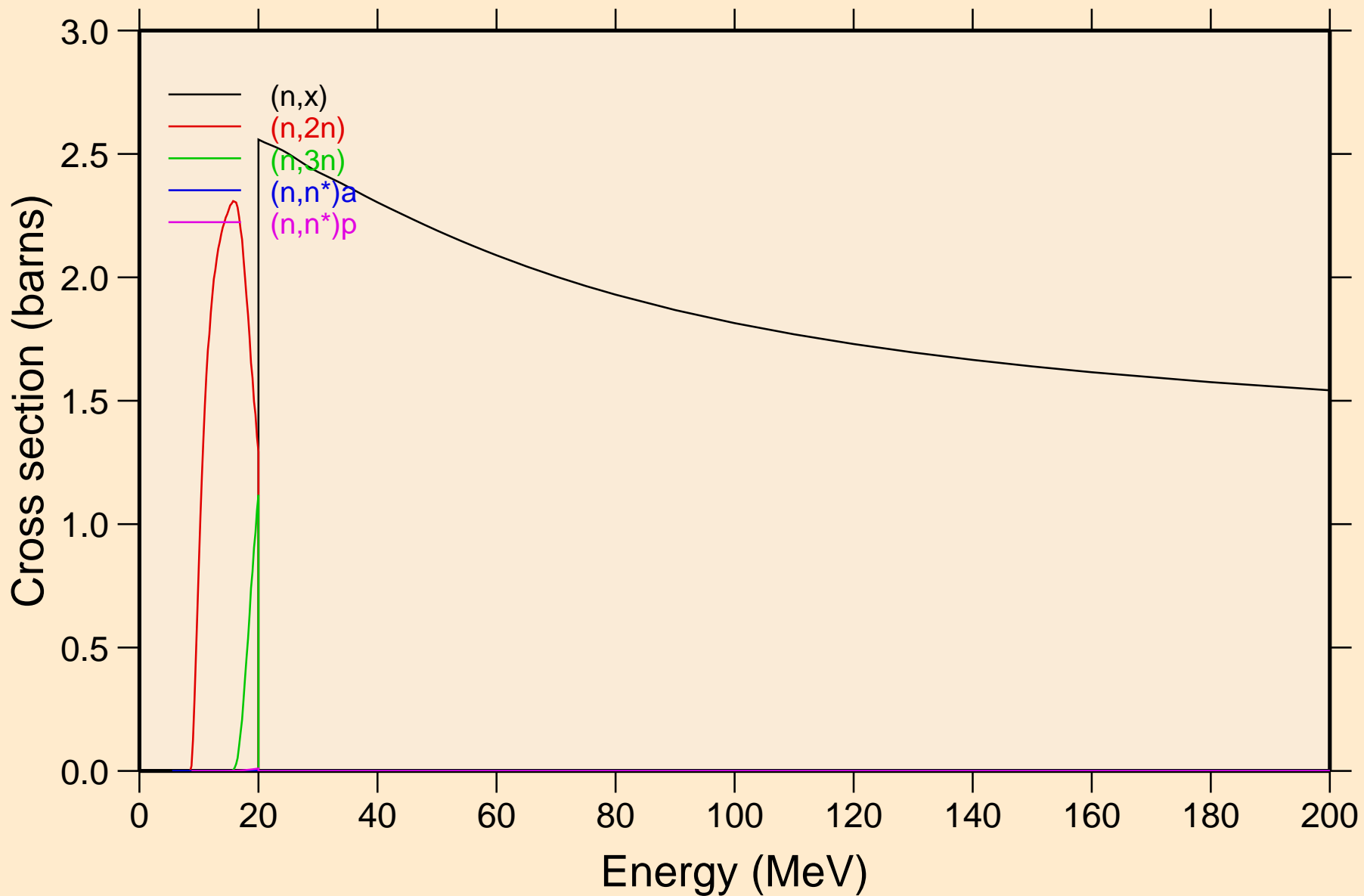

68-ER-166 FOR FENDL-3.1 FROM FENDL-3.1 WITH NJOY2012.50
Threshold reactions

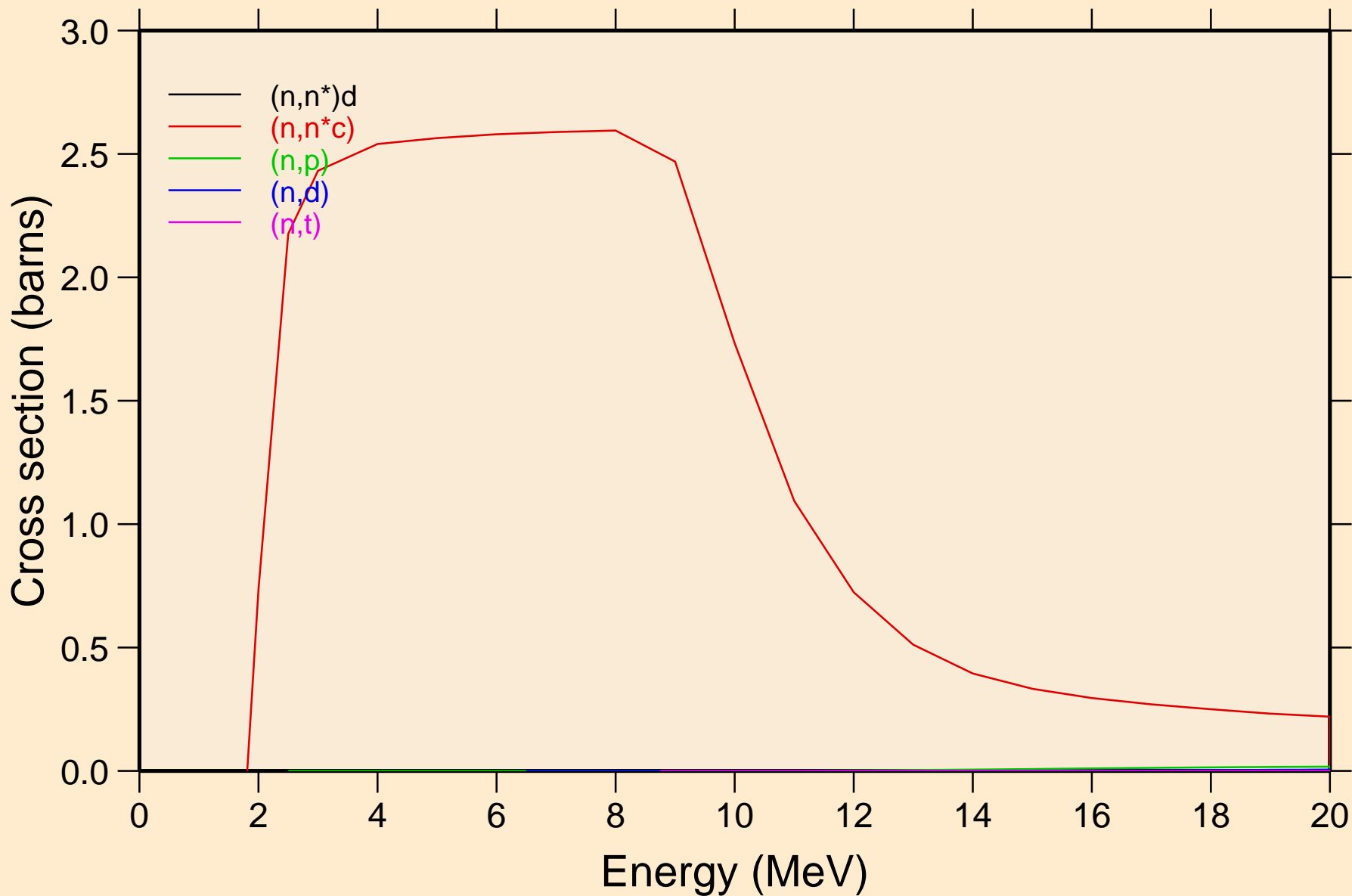

68-ER-166 FOR FENDL-3.1 FROM FENDL-3.1 WITH NJOY2012.50
Threshold reactions

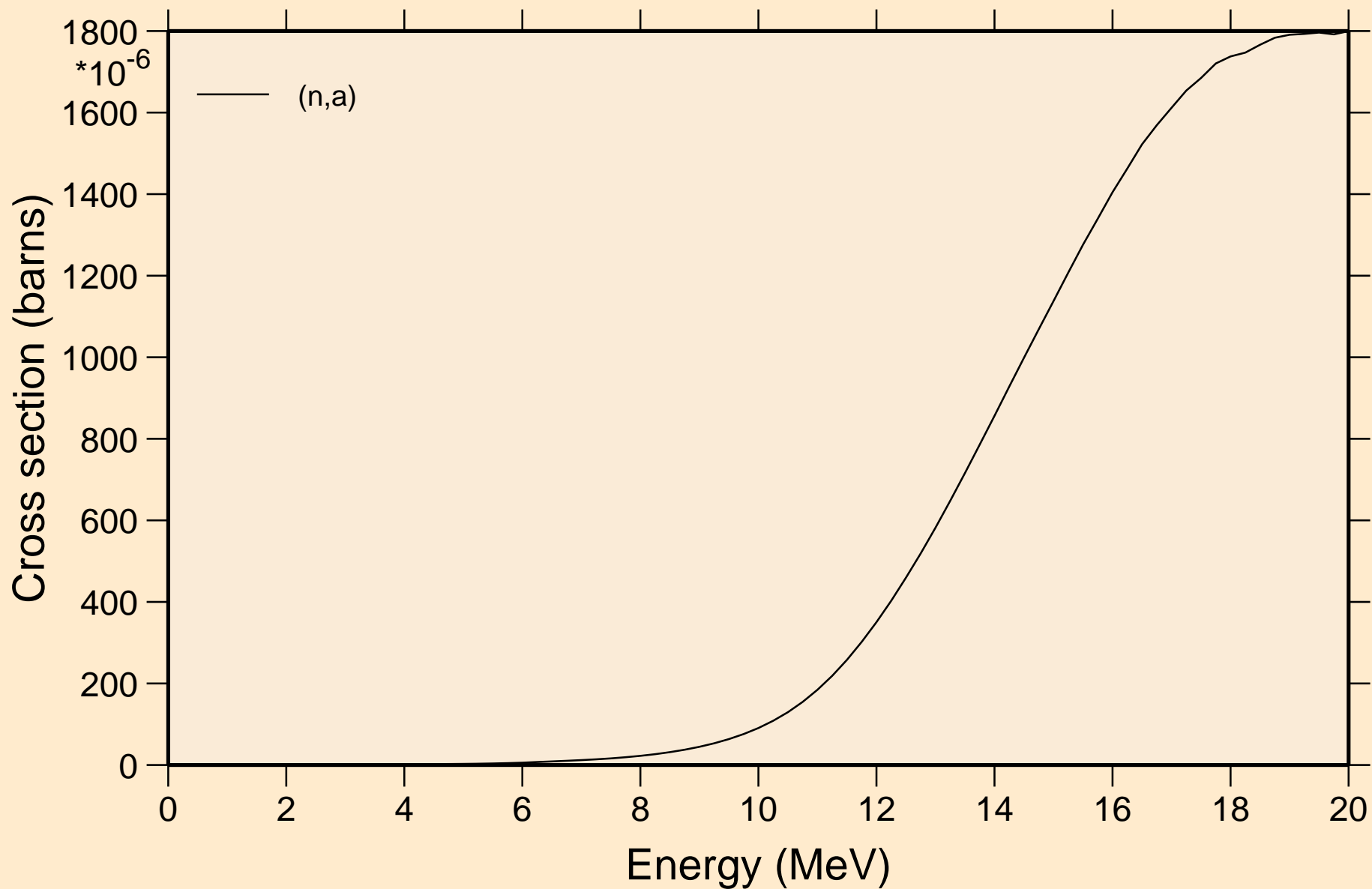

68-ER-166 FOR FENDL-3.1 FROM FENDL-3.1 WITH NJOY2012.50
Threshold reactions

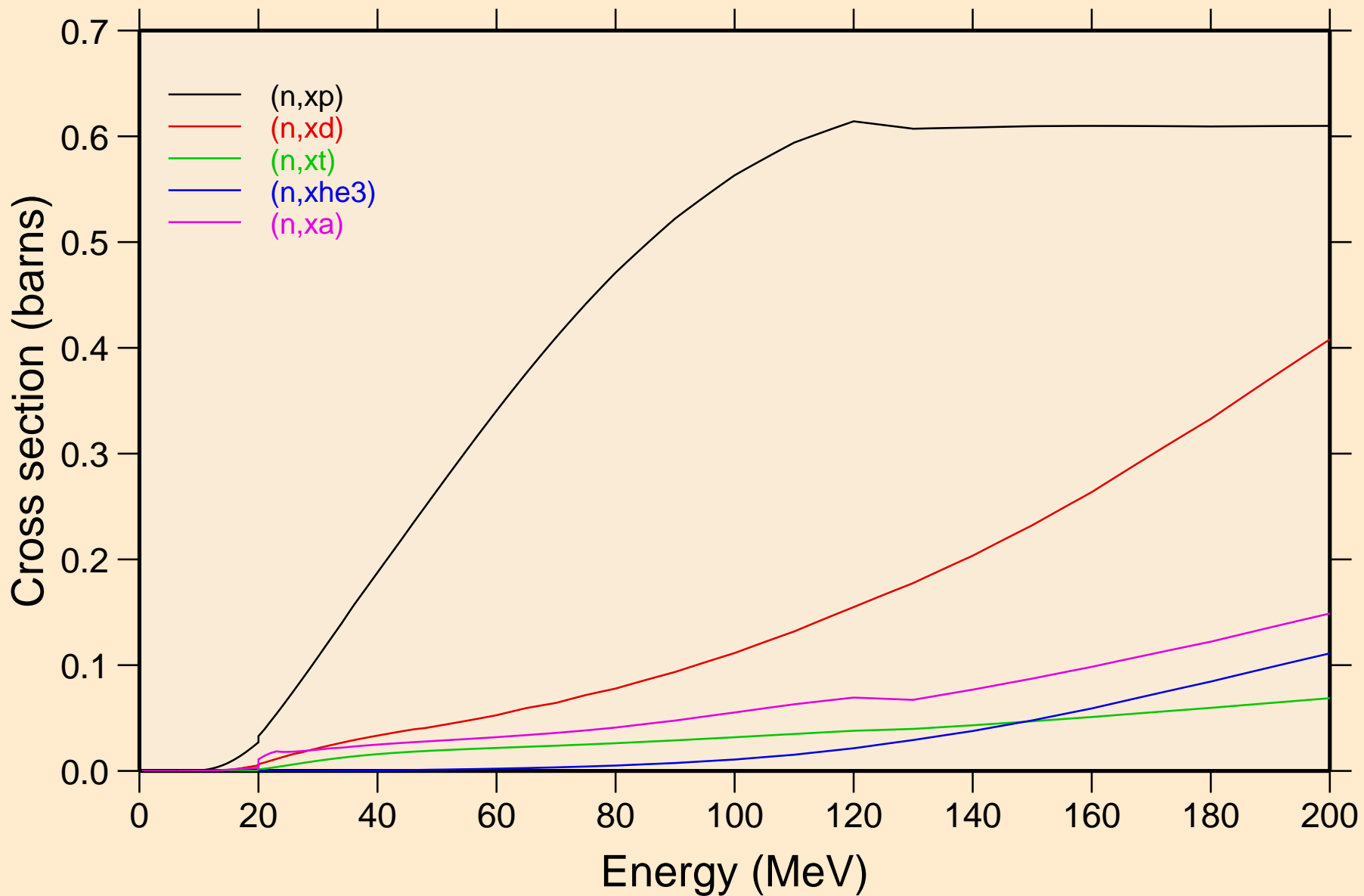

68-ER-166 FOR FENDL-3.1 FROM FENDL-3.1 WITH NJOY2012.50
angular distribution for elastic

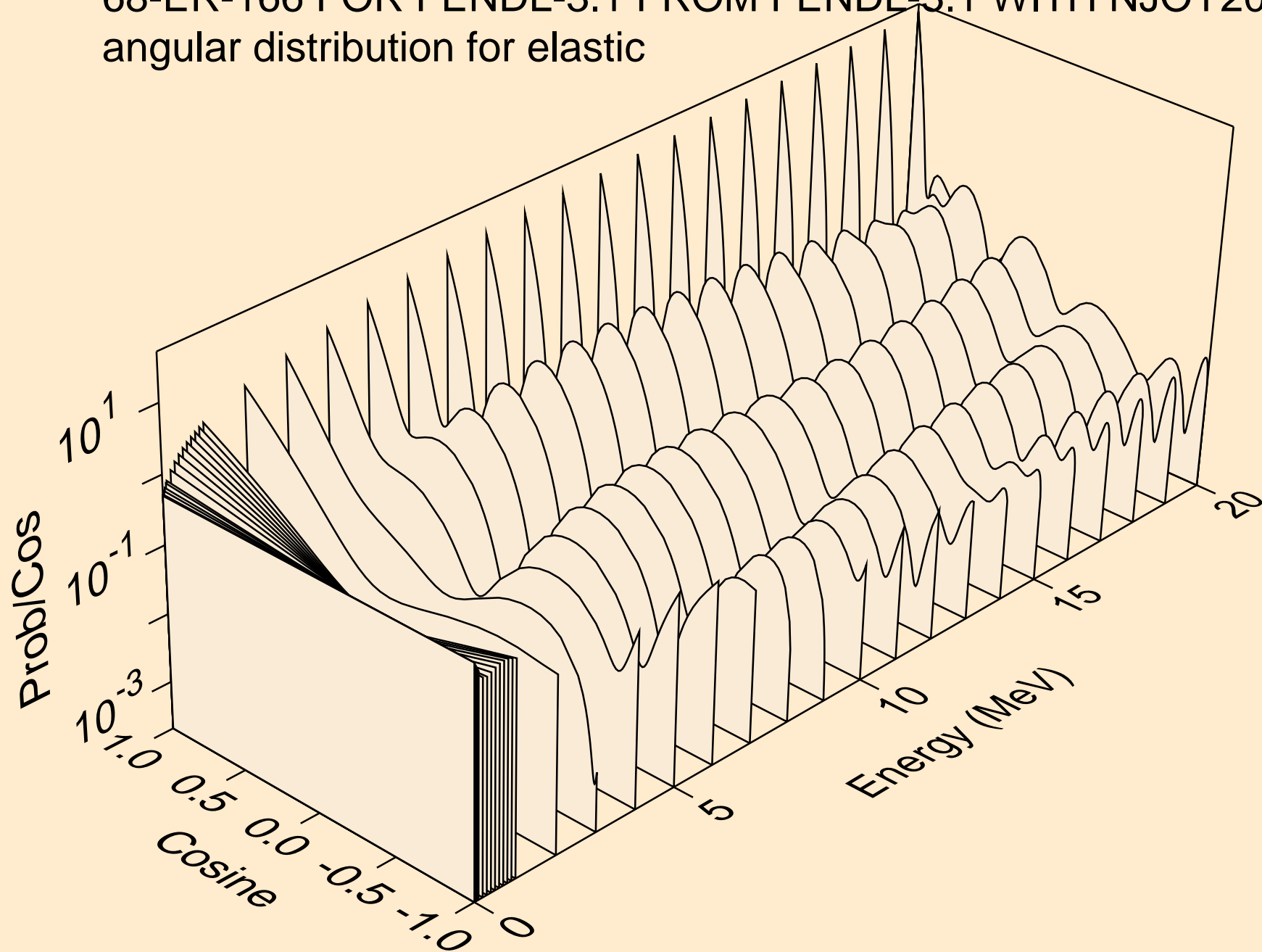

68-ER-166 FOR FENDL-3.1 FROM FENDL-3.1 WITH NJOY2012.50
angular distribution for elastic

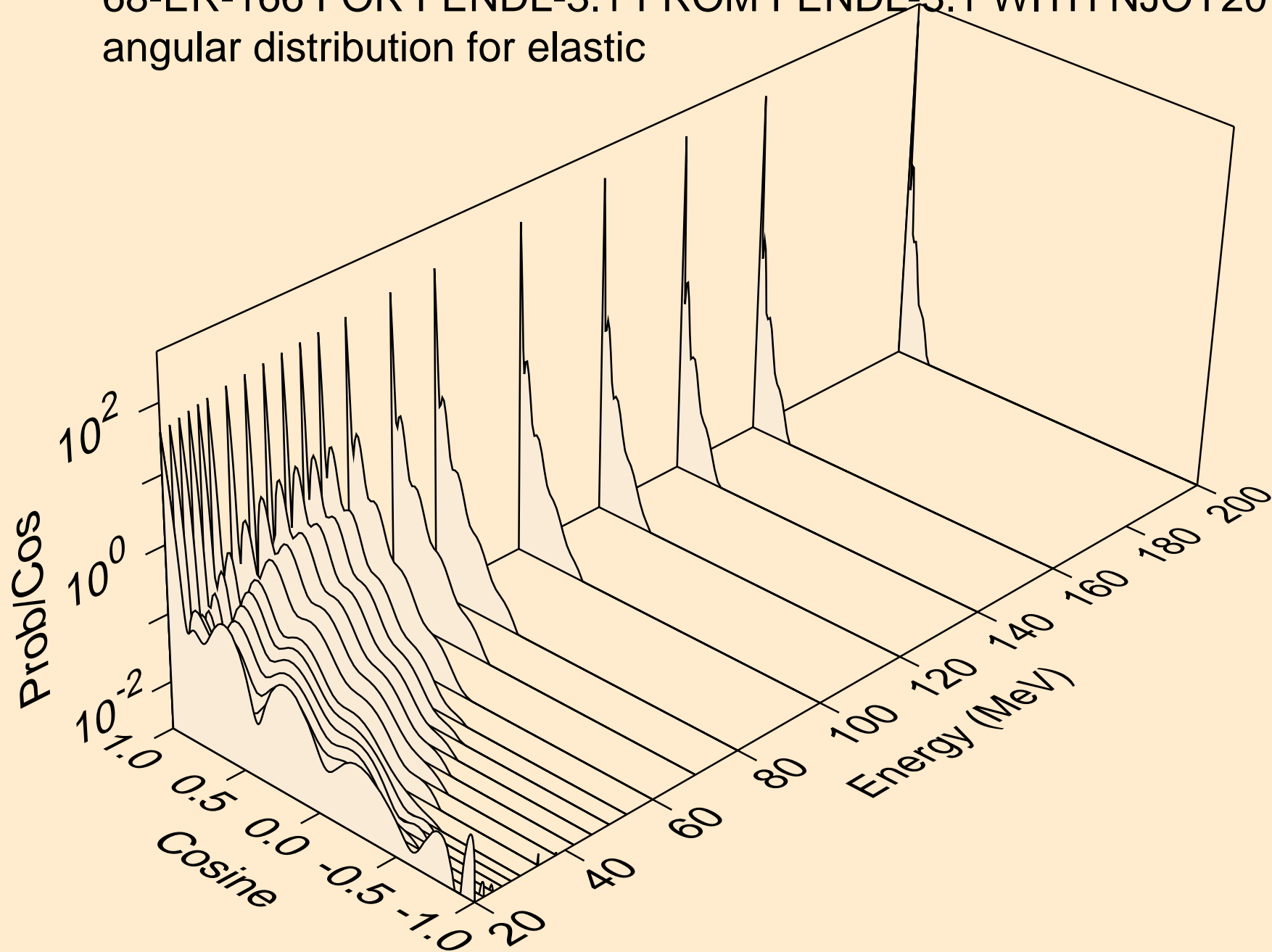

68-ER-166 FOR FENDL-3.1 FROM FENDL-3.1 WITH NJOY2012.50
angular distribution for (n,n*1)

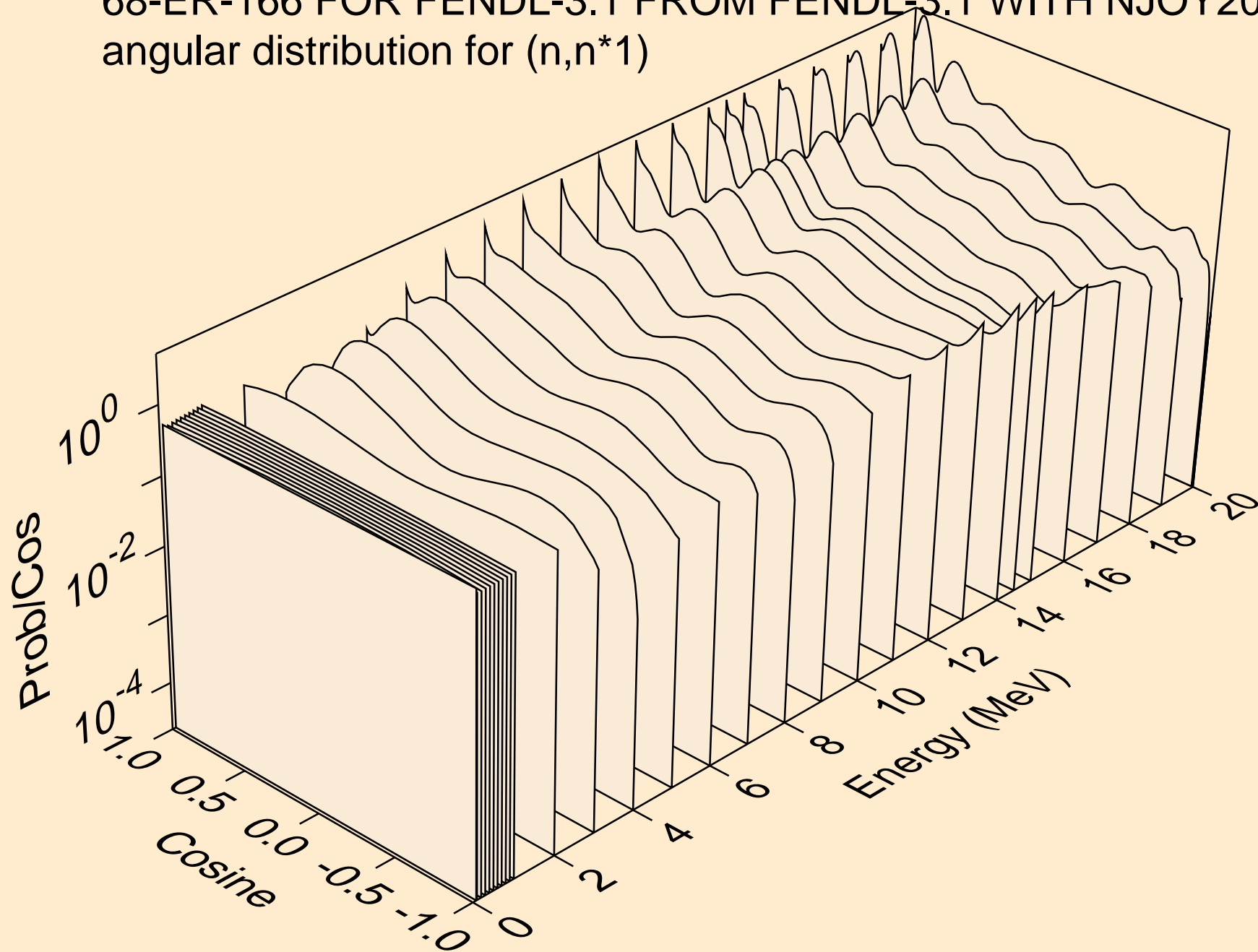

68-ER-166 FOR FENDL-3.1 FROM FENDL-3.1 WITH NJOY2012.50
angular distribution for (n,n*2)

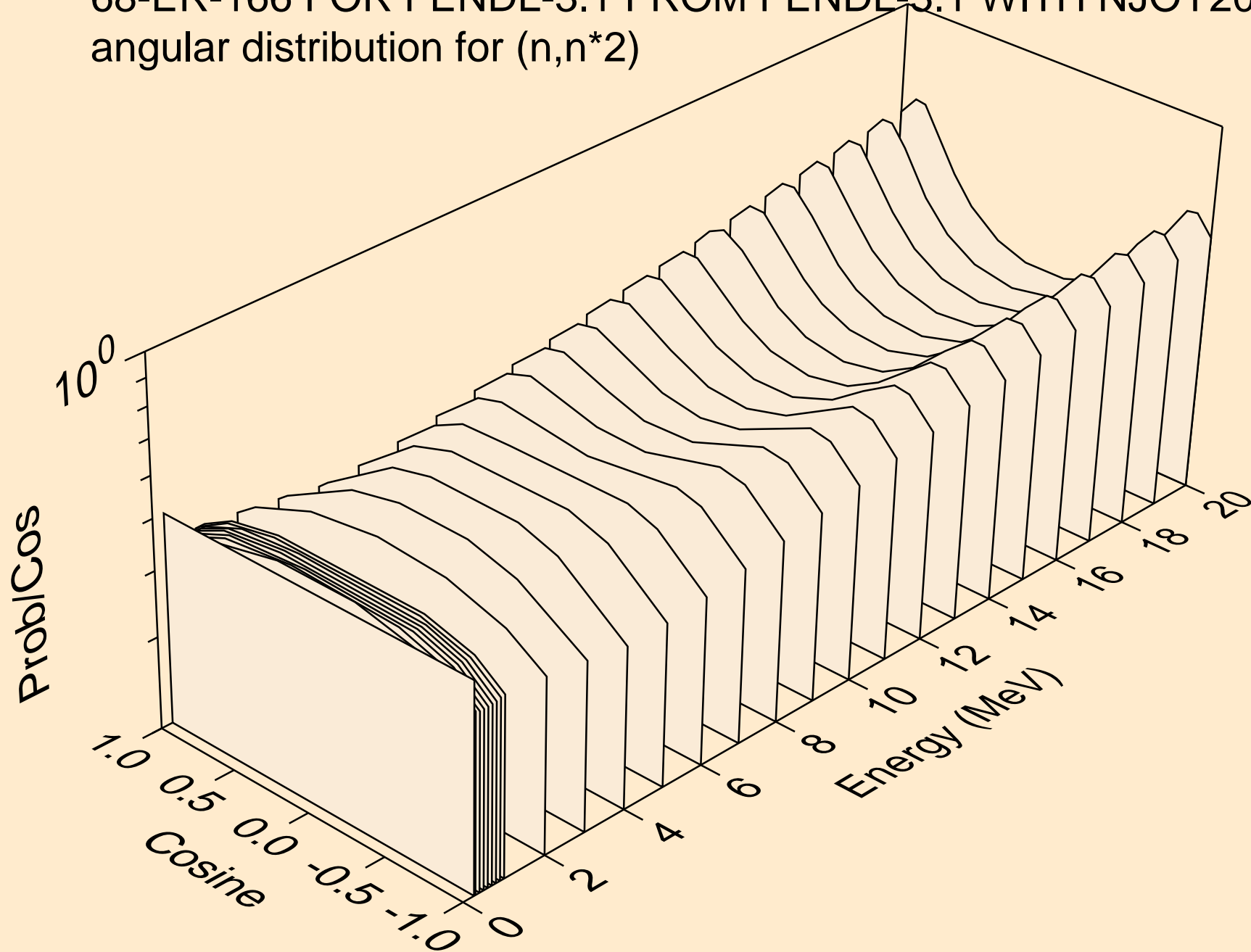

68-ER-166 FOR FENDL-3.1 FROM FENDL-3.1 WITH NJOY2012.50
angular distribution for (n,n*3)

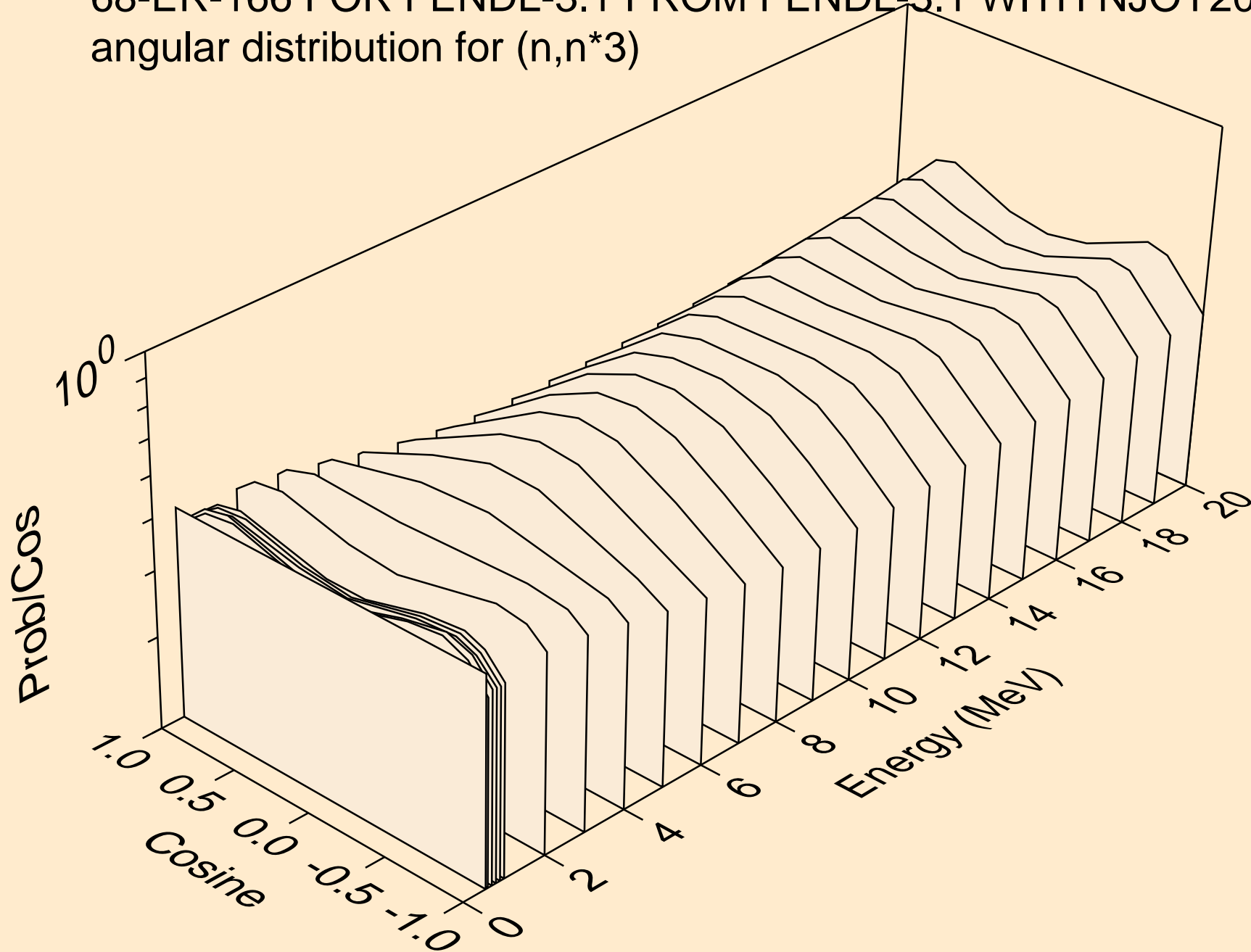

68-ER-166 FOR FENDL-3.1 FROM FENDL-3.1 WITH NJOY2012.50
angular distribution for (n,n*4)

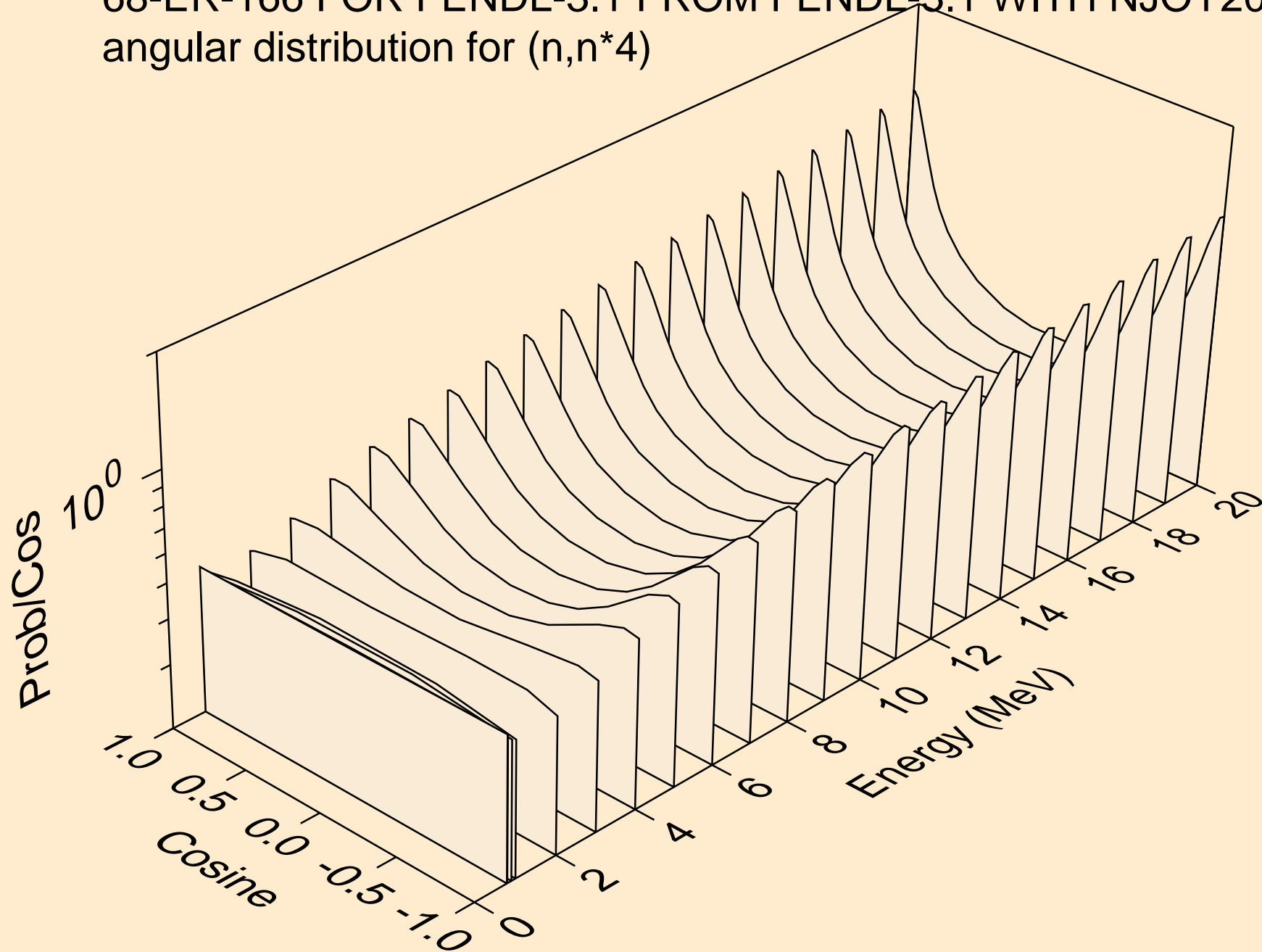

68-ER-166 FOR FENDL-3.1 FROM FENDL-3.1 WITH NJOY2012.50
angular distribution for (n,n*5)

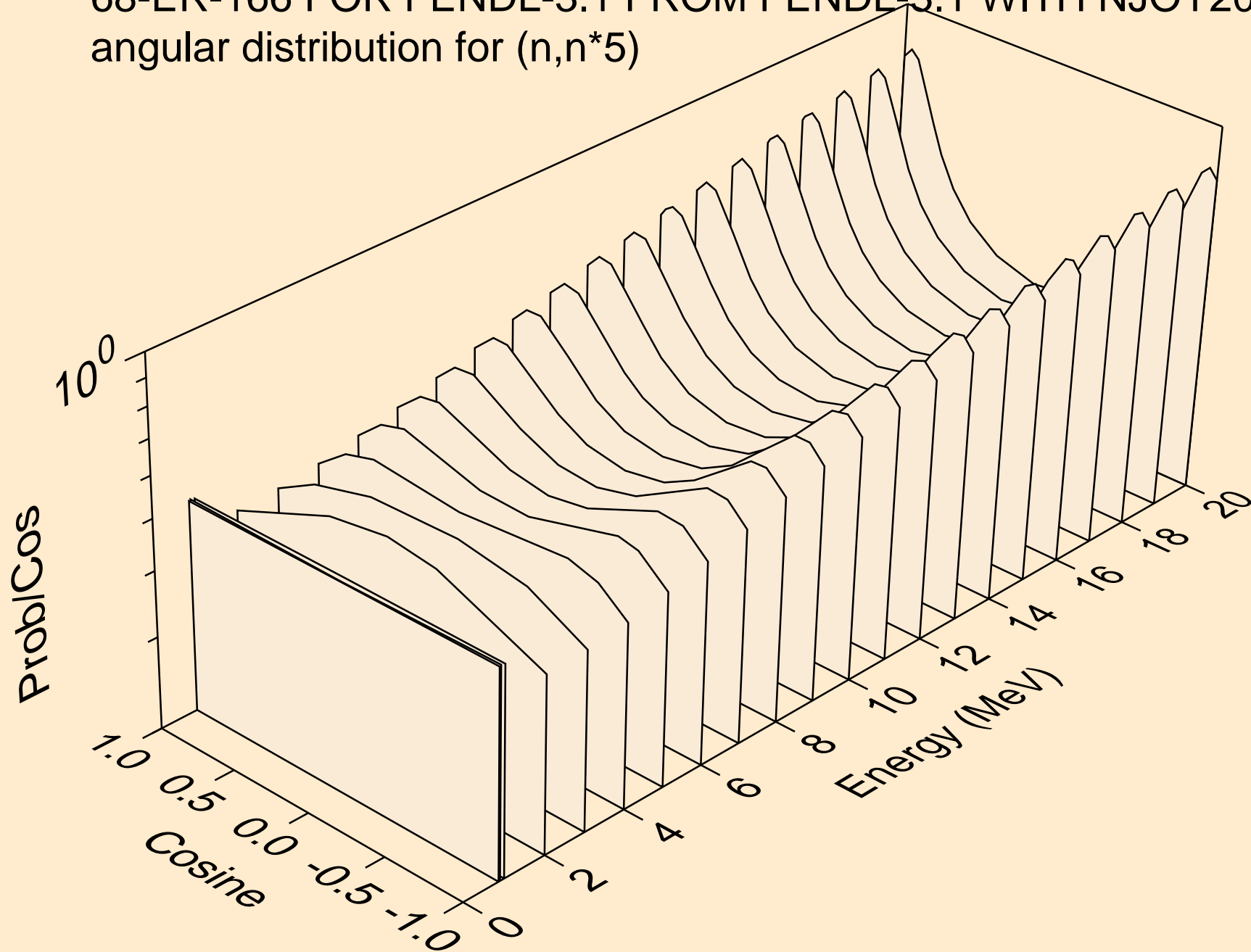

68-ER-166 FOR FENDL-3.1 FROM FENDL-3.1 WITH NJOY2012.50
angular distribution for (n,n*6)

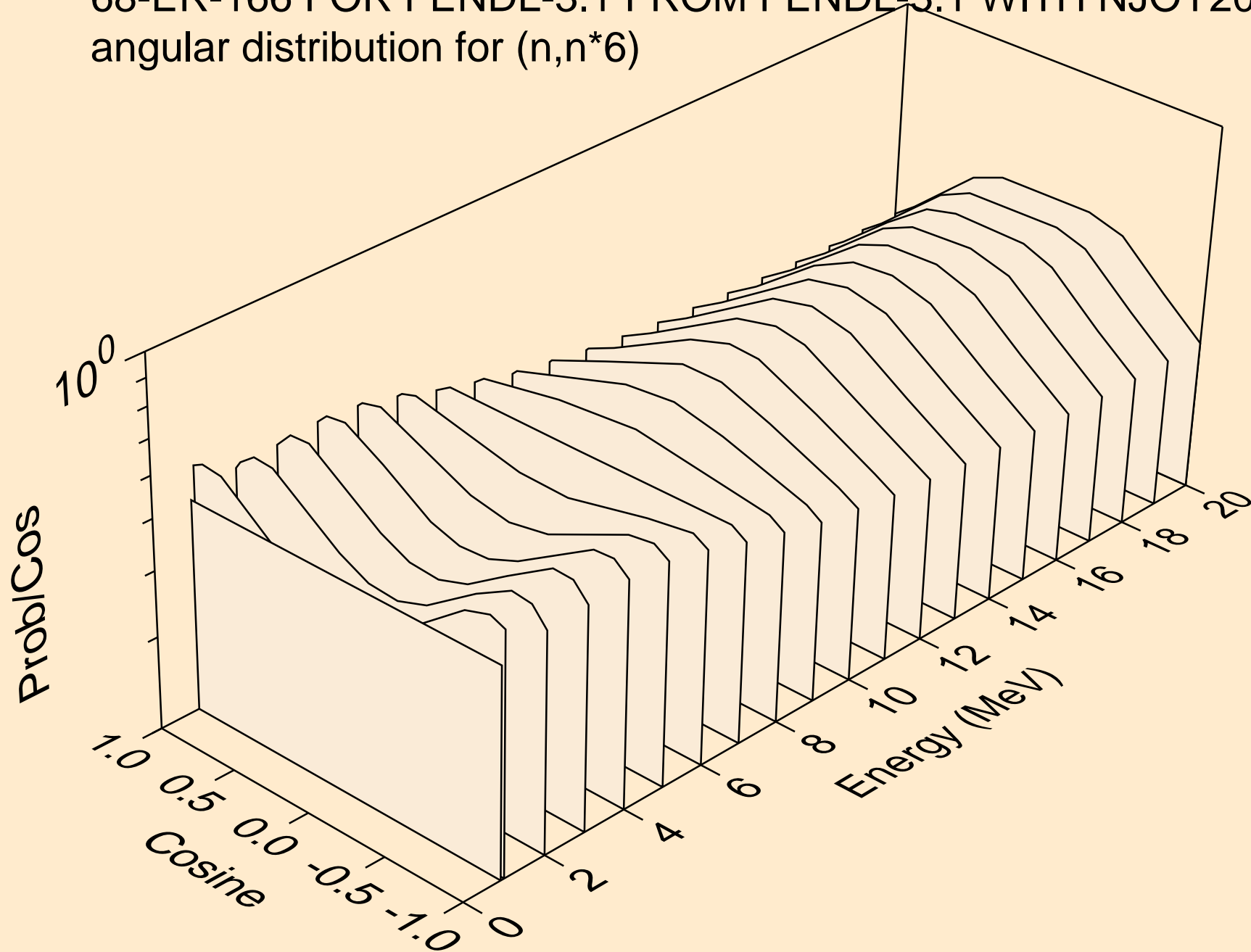

68-ER-166 FOR FENDL-3.1 FROM FENDL-3.1 WITH NJOY2012.50
angular distribution for (n,n*7)

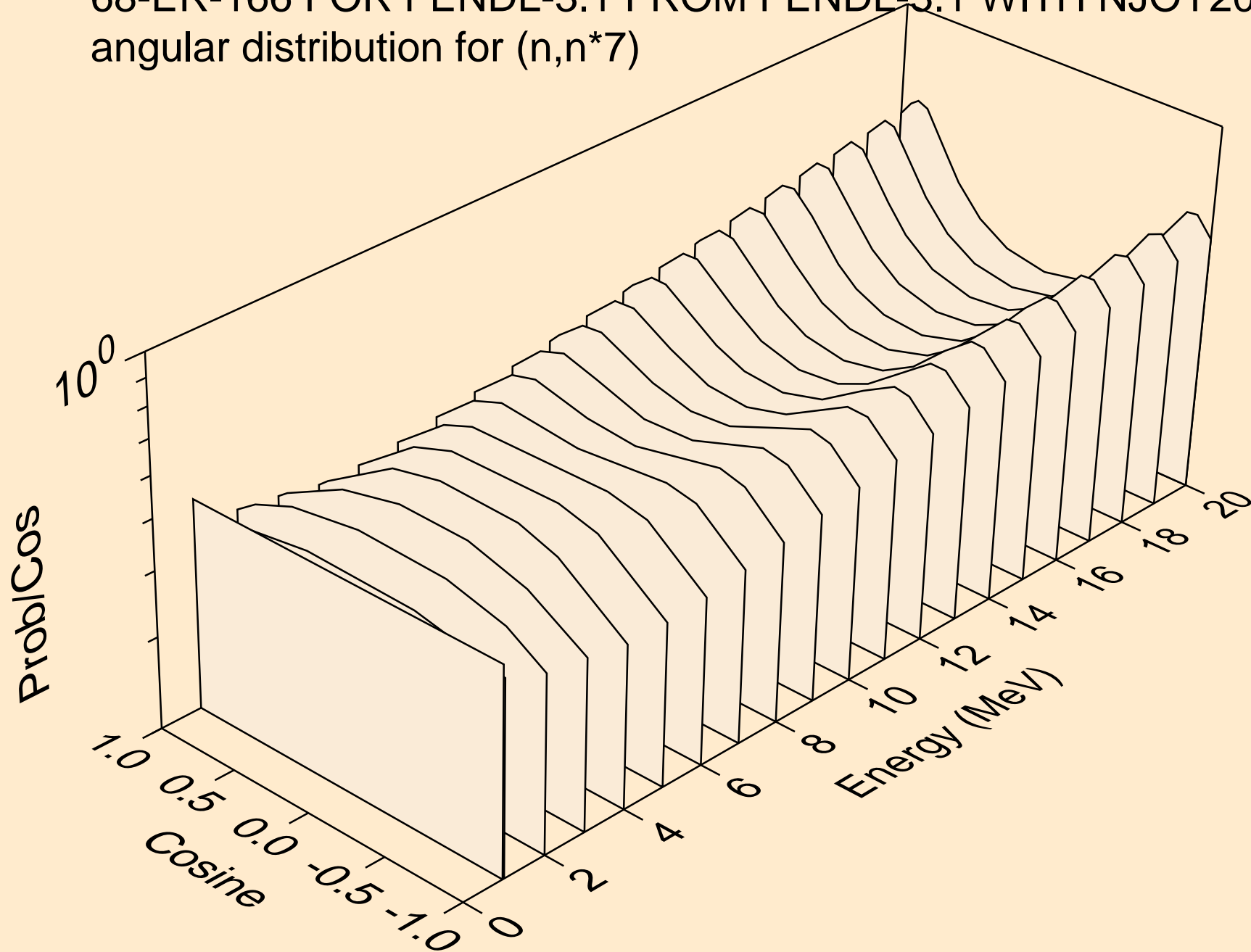

68-ER-166 FOR FENDL-3.1 FROM FENDL-3.1 WITH NJOY2012.50
angular distribution for (n,n*8)

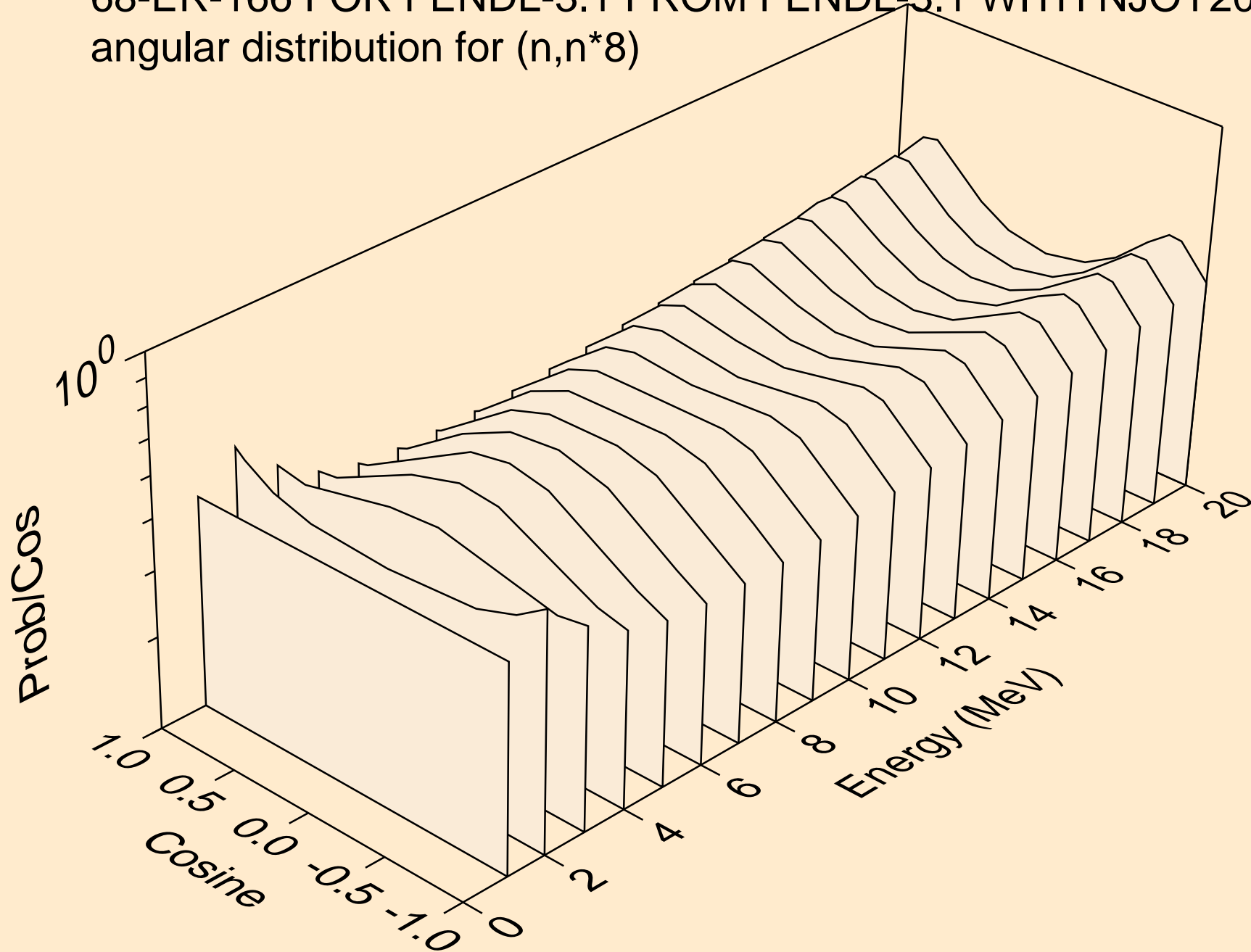

68-ER-166 FOR FENDL-3.1 FROM FENDL-3.1 WITH NJOY2012.50
angular distribution for (n,n*9)

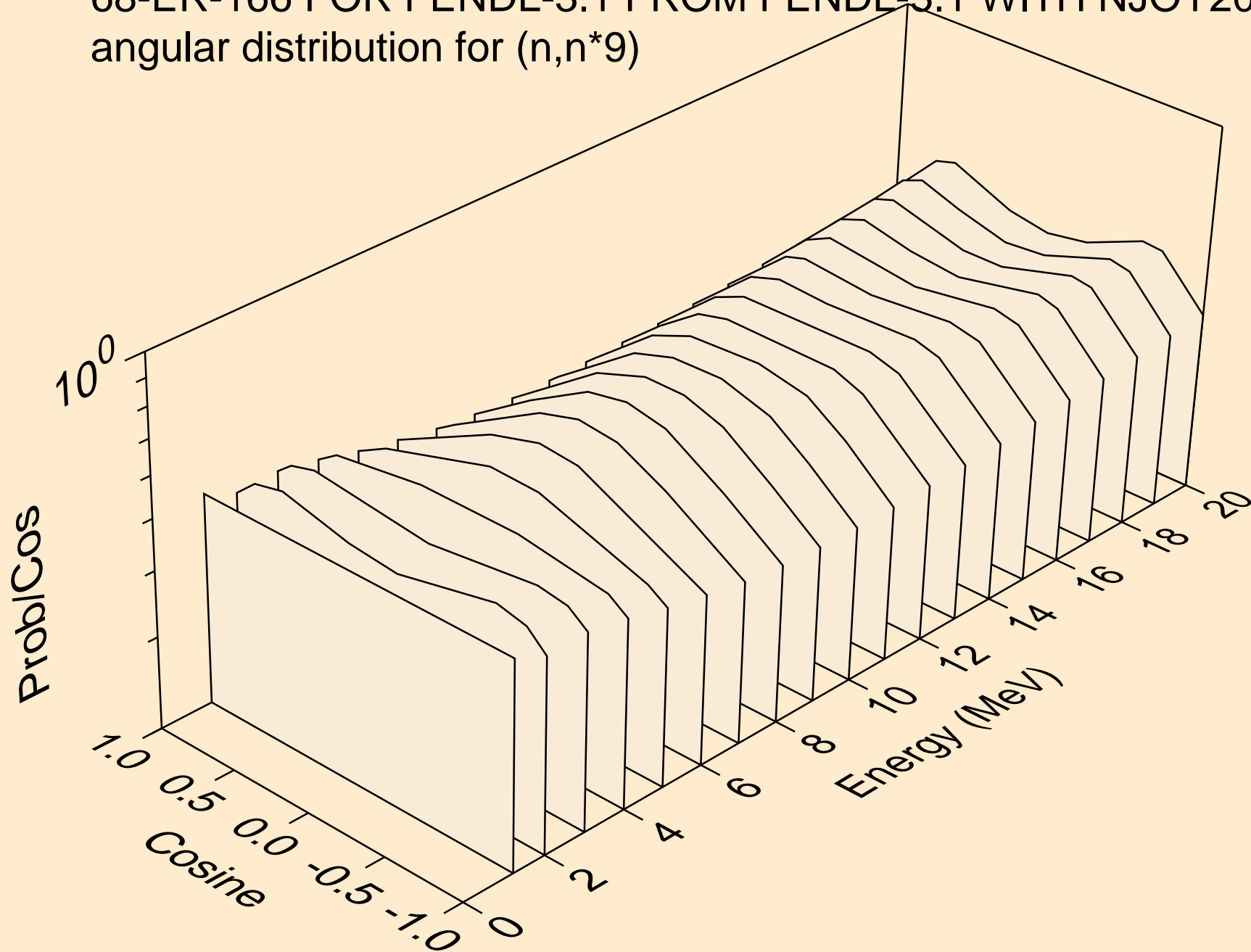

68-ER-166 FOR FENDL-3.1 FROM FENDL-3.1 WITH NJOY2012.50
angular distribution for (n,n*10)

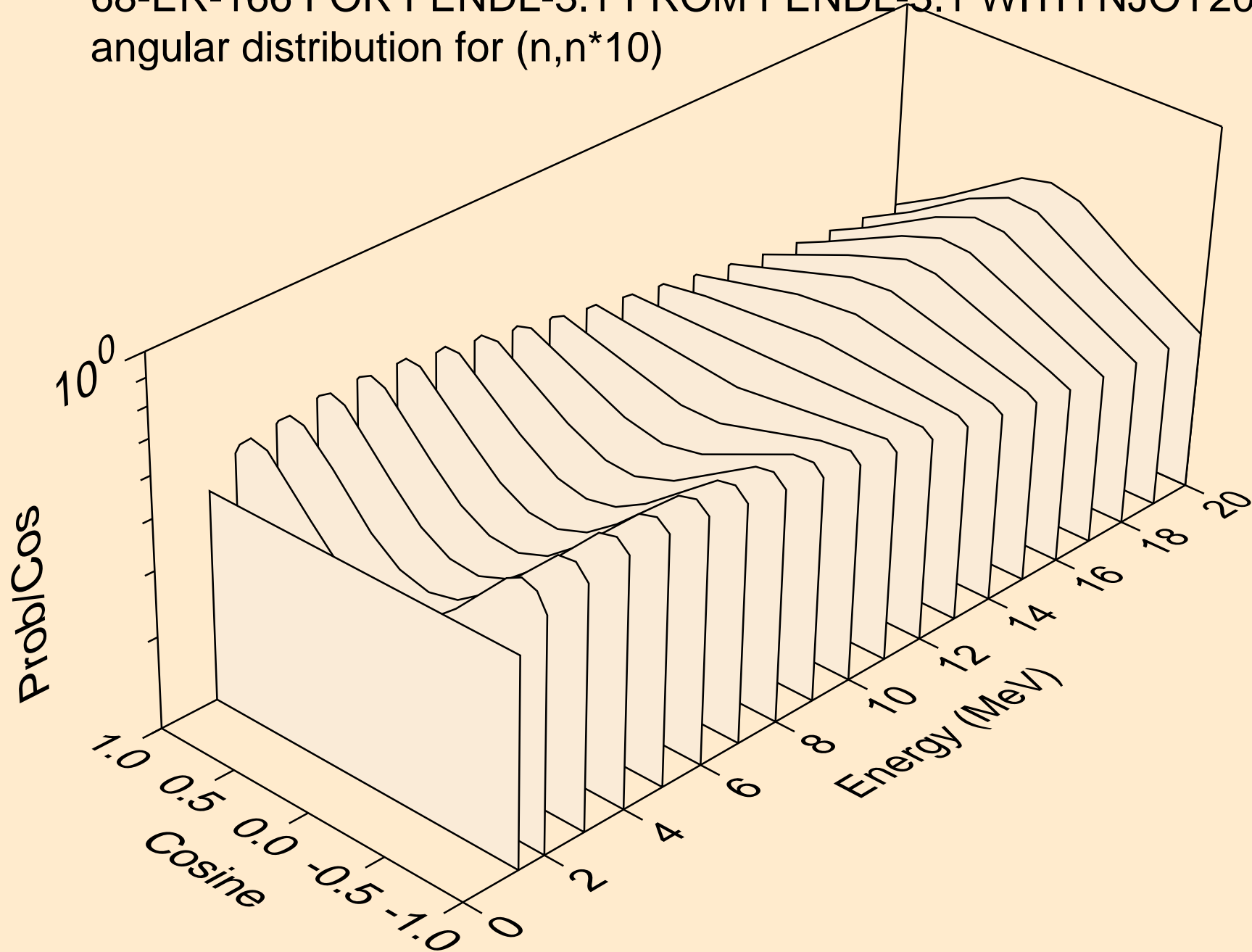

68-ER-166 FOR FENDL-3.1 FROM FENDL-3.1 WITH NJOY2012.50
angular distribution for (n,n*11)

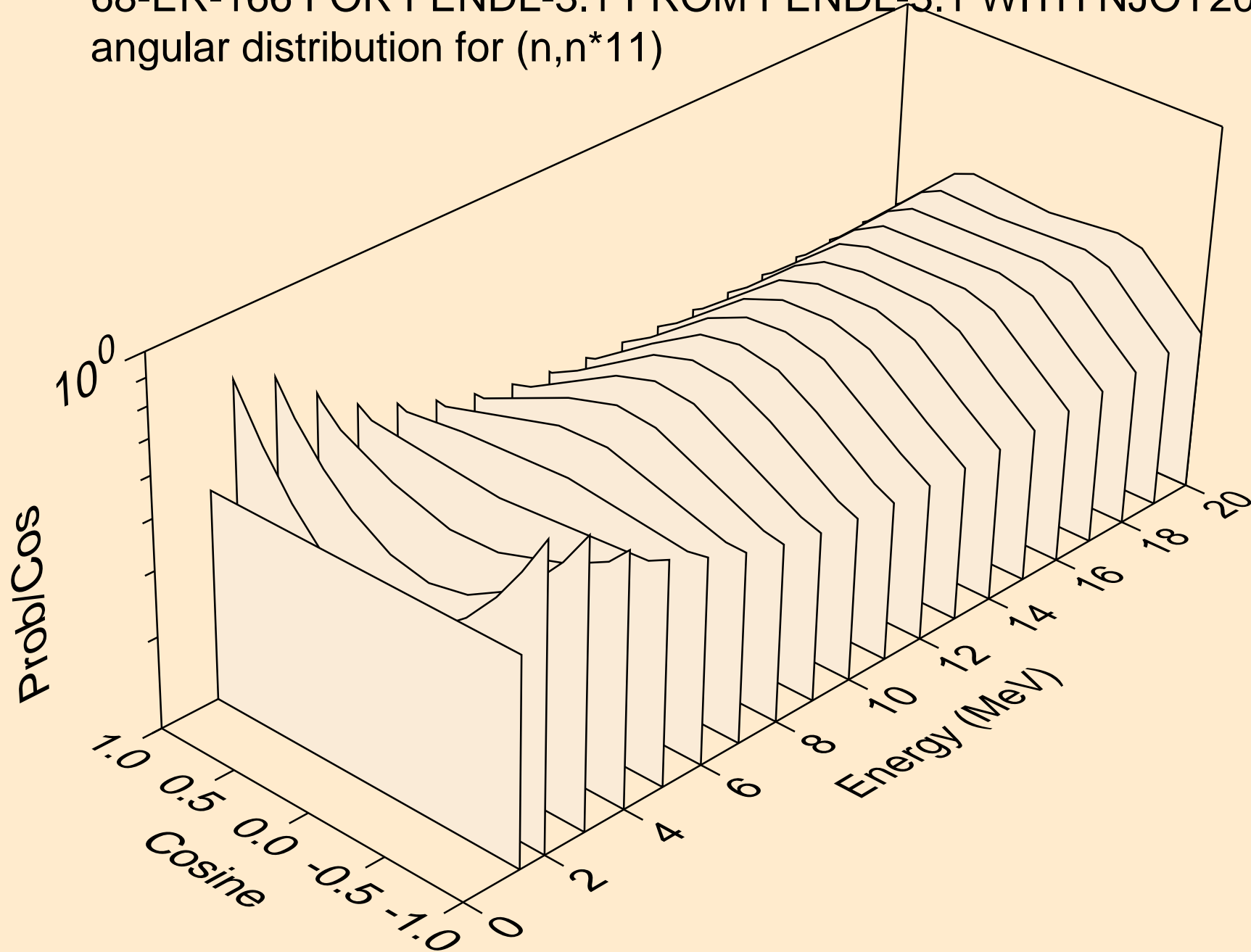

68-ER-166 FOR FENDL-3.1 FROM FENDL-3.1 WITH NJOY2012.50
angular distribution for (n,n*12)

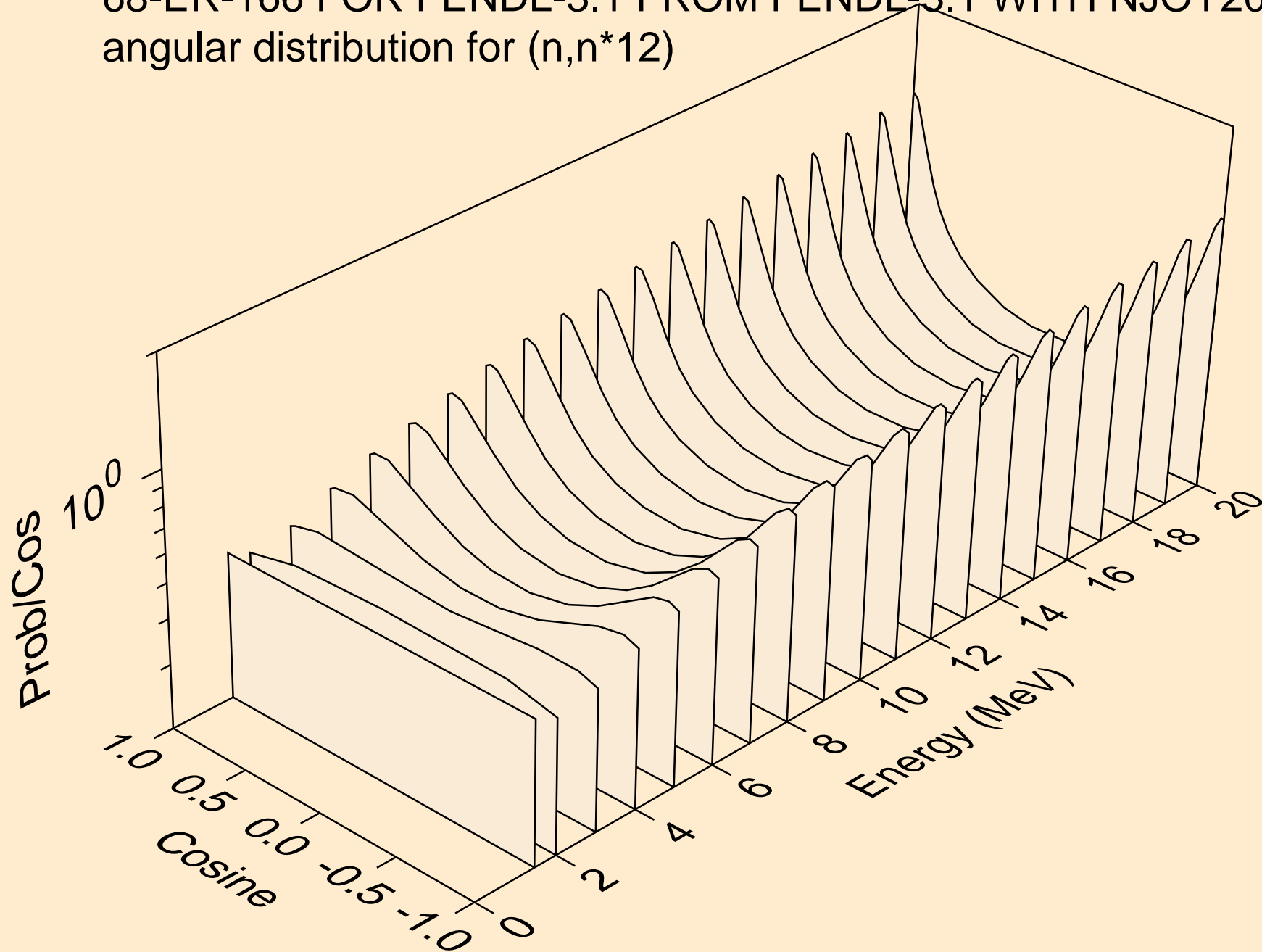

68-ER-166 FOR FENDL-3.1 FROM FENDL-3.1 WITH NJOY2012.50
angular distribution for (n,n*13)

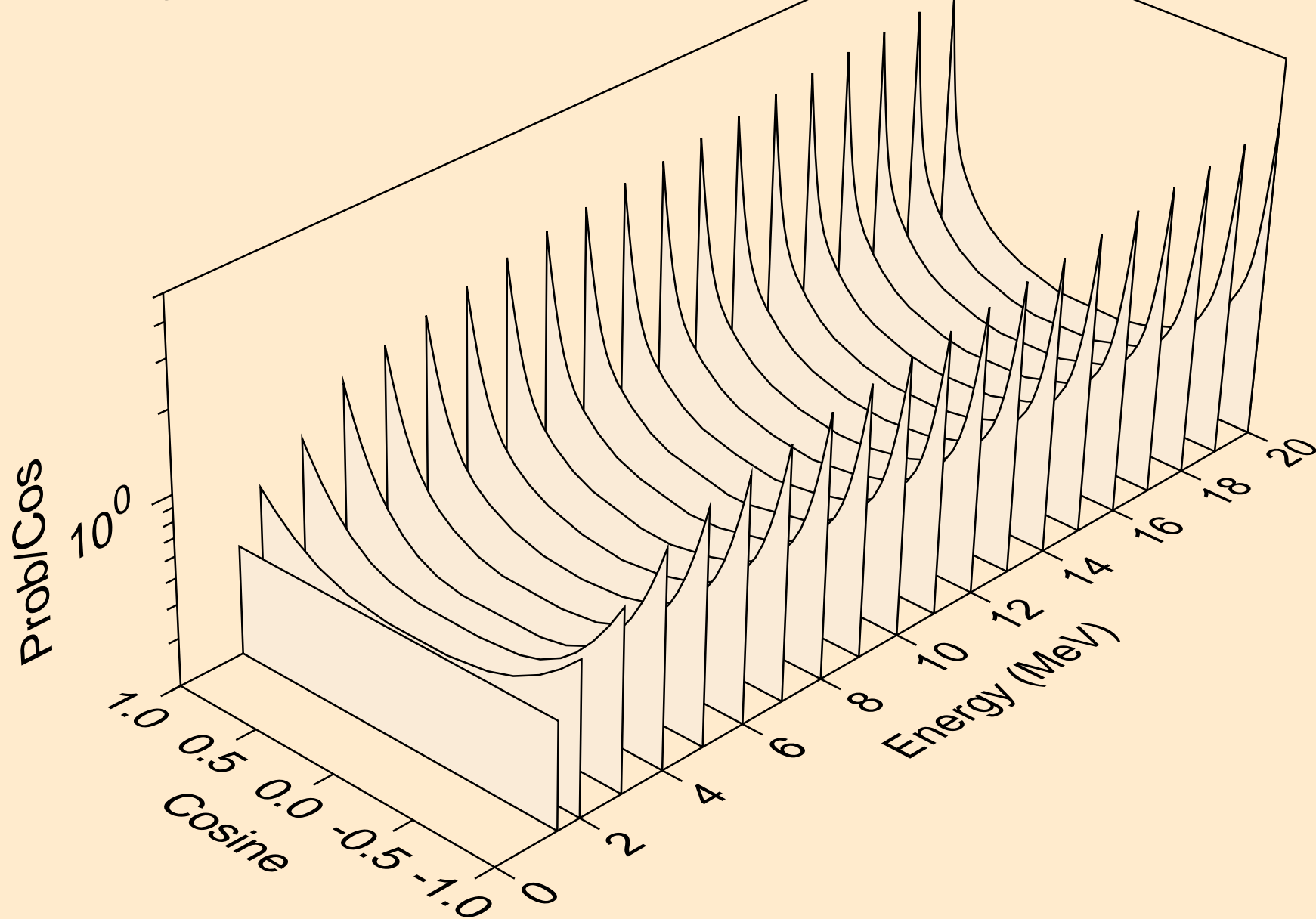

68-ER-166 FOR FENDL-3.1 FROM FENDL-3.1 WITH NJOY2012.50
angular distribution for (n,n*14)

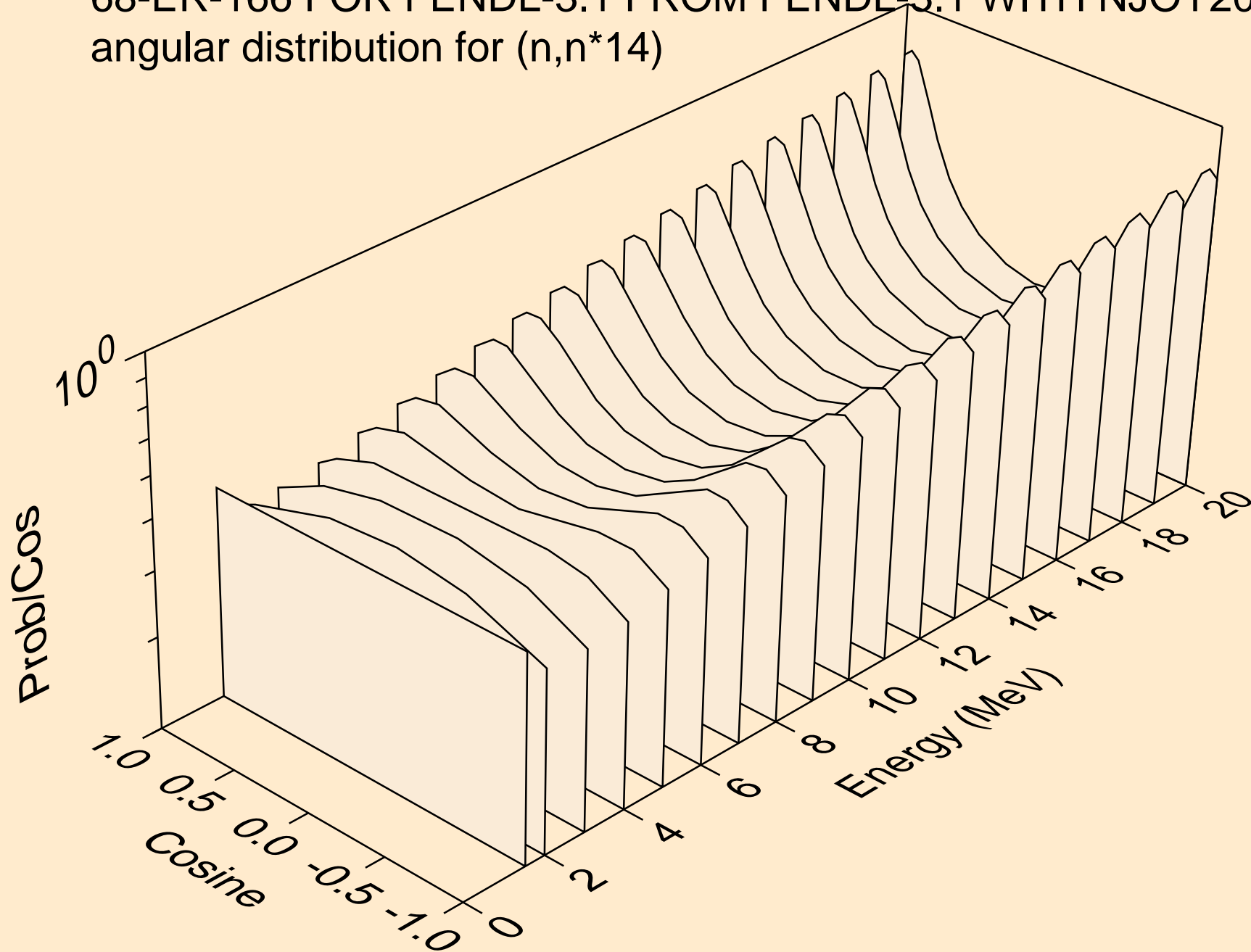

68-ER-166 FOR FENDL-3.1 FROM FENDL-3.1 WITH NJOY2012.50
angular distribution for (n,n*15)

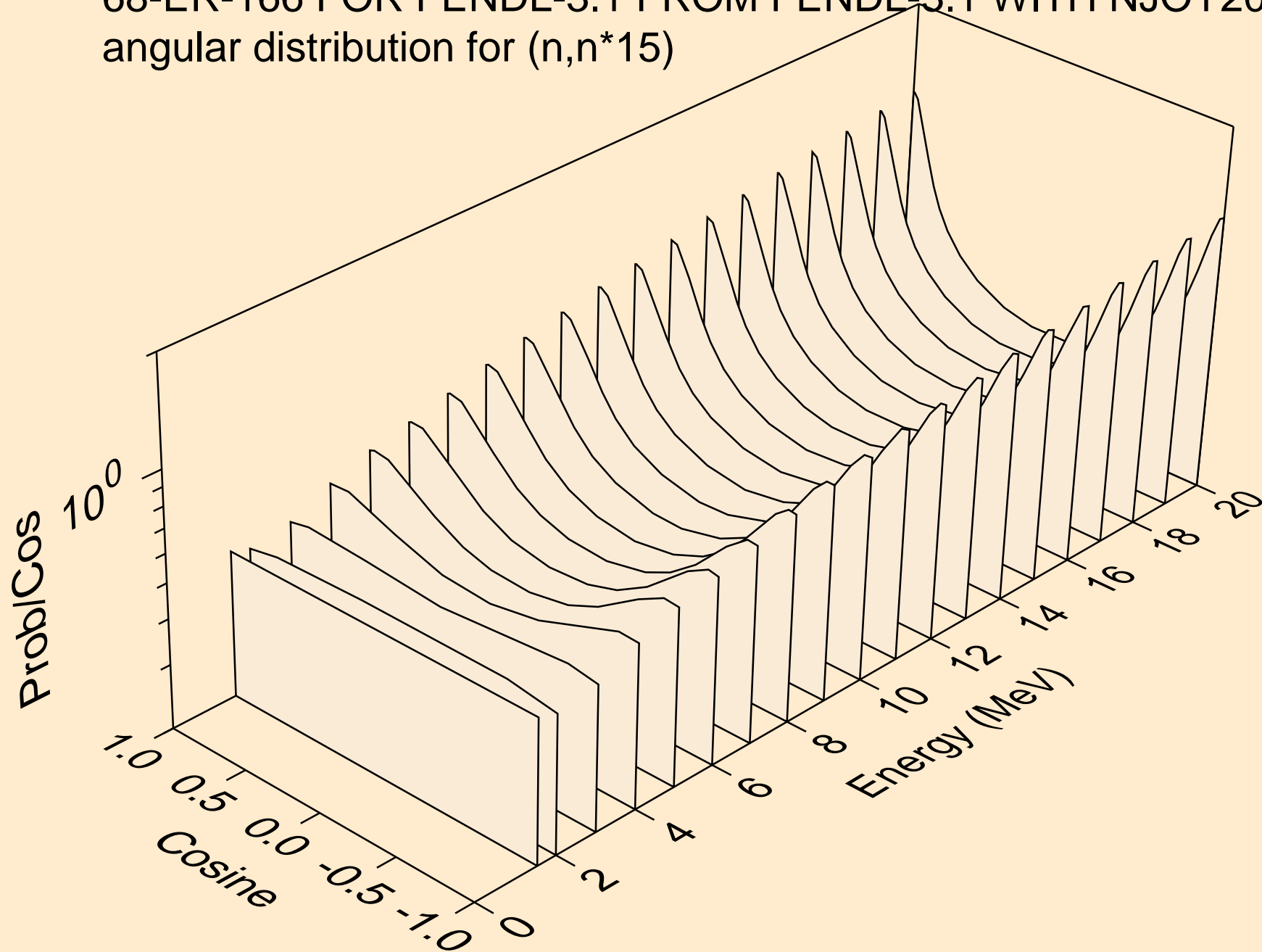

68-ER-166 FOR FENDL-3.1 FROM FENDL-3.1 WITH NJOY2012.50
angular distribution for (n,n*16)

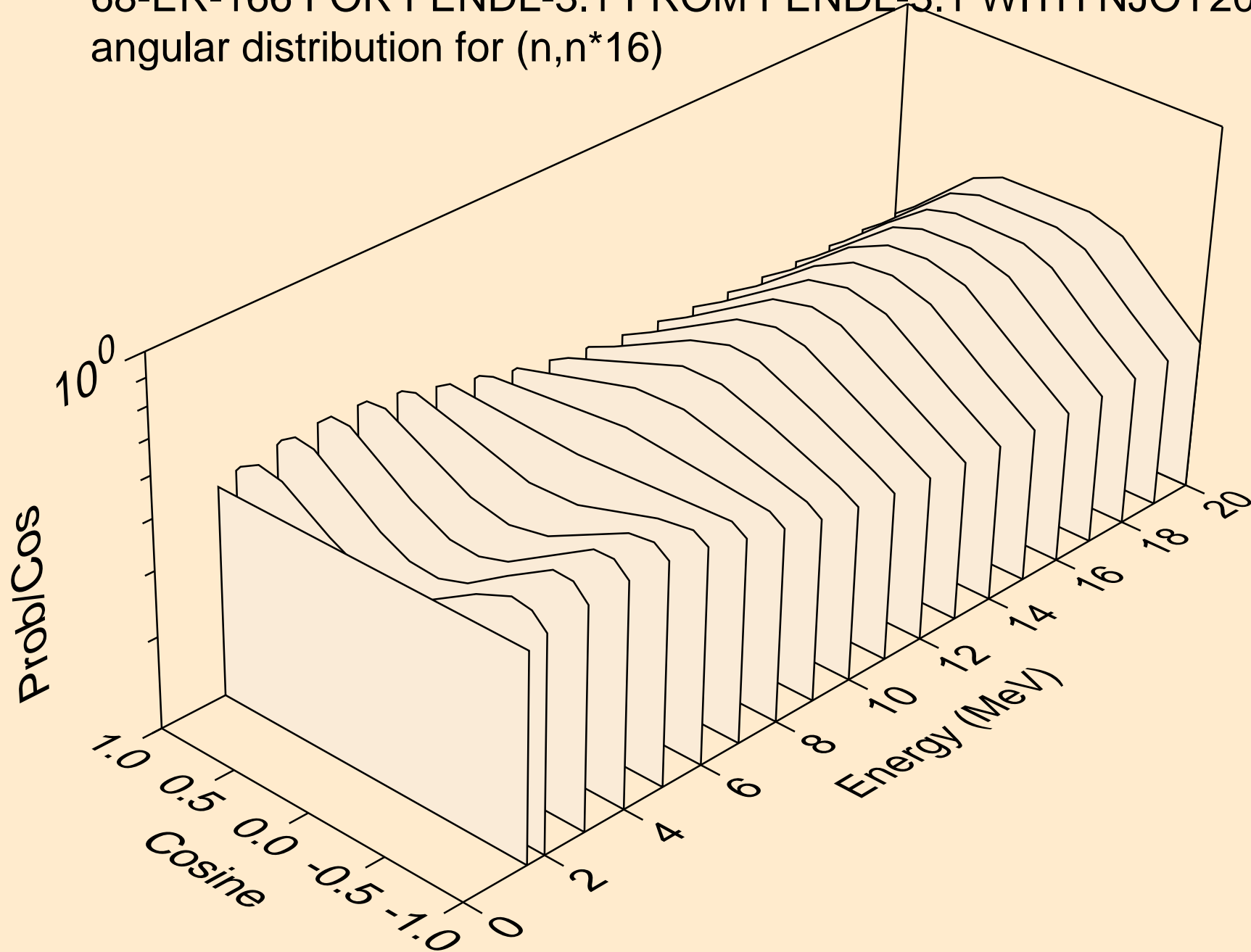

68-ER-166 FOR FENDL-3.1 FROM FENDL-3.1 WITH NJOY2012.50
angular distribution for (n,n*17)

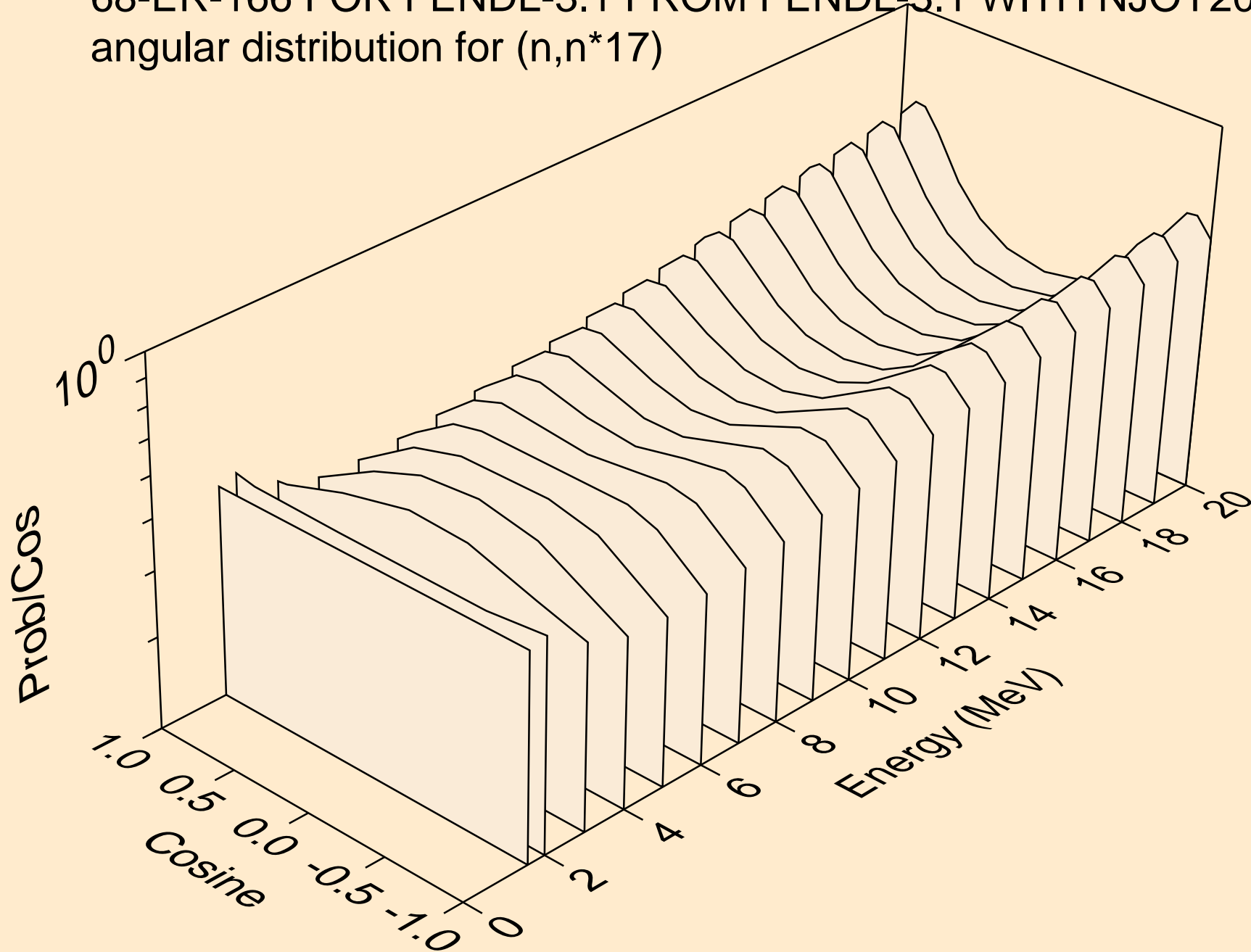

68-ER-166 FOR FENDL-3.1 FROM FENDL-3.1 WITH NJOY2012.50
angular distribution for (n,n*18)

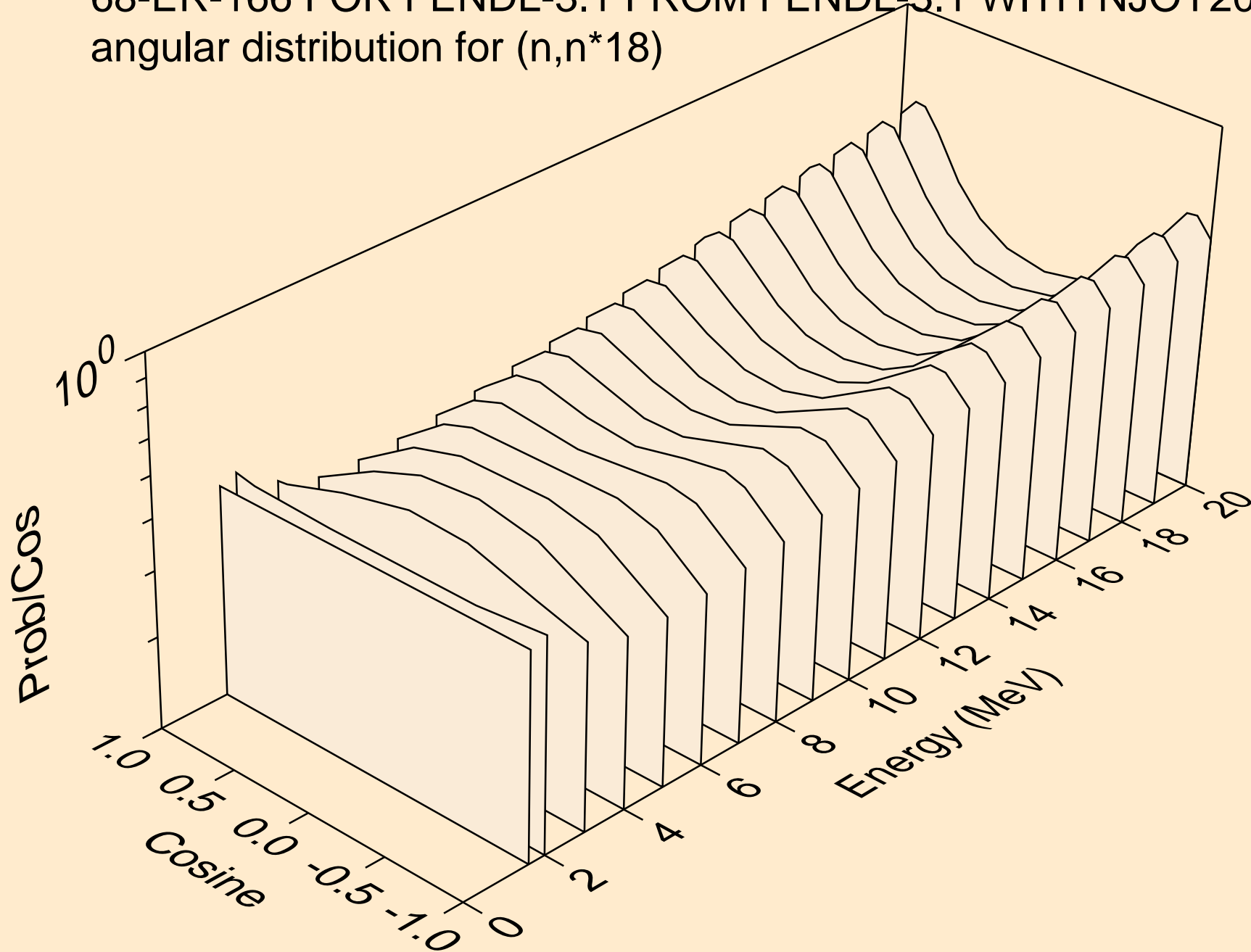

68-ER-166 FOR FENDL-3.1 FROM FENDL-3.1 WITH NJOY2012.50
angular distribution for (n,n*19)

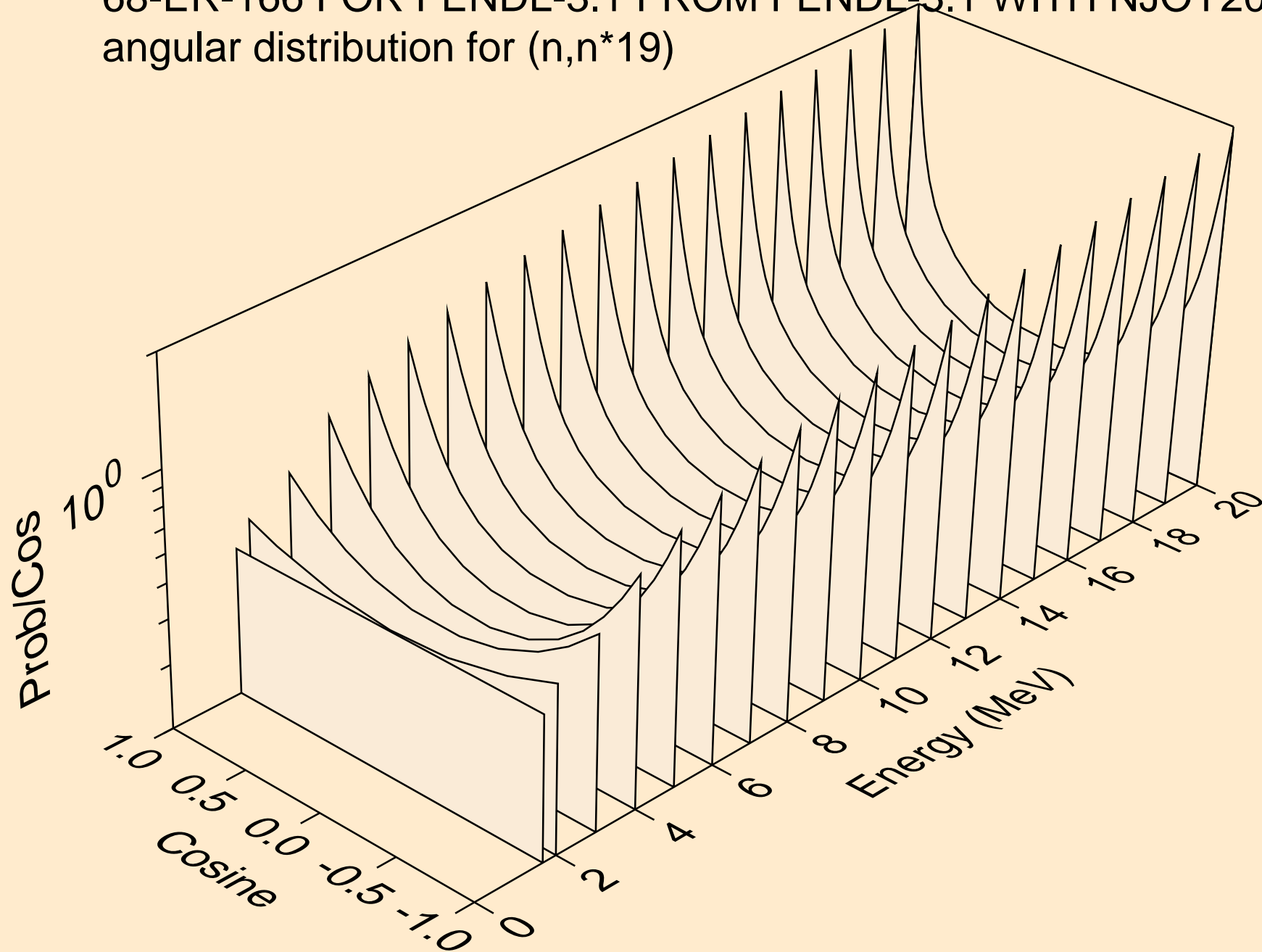

68-ER-166 FOR FENDL-3.1 FROM FENDL-3.1 WITH NJOY2012.50
angular distribution for (n,n*20)

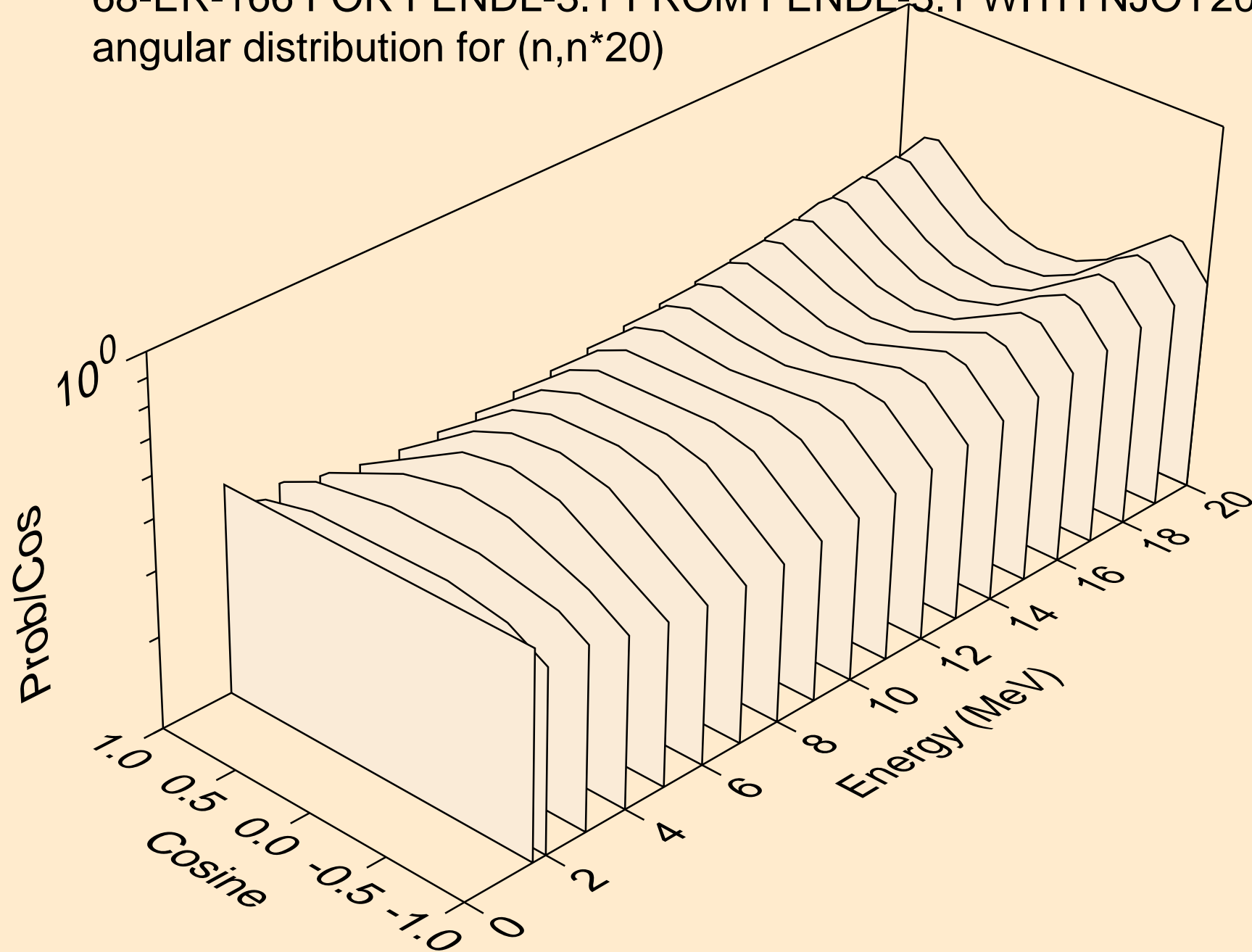

68-ER-166 FOR FENDL-3.1 FROM FENDL-3.1 WITH NJOY2012.50
angular distribution for (n,n*21)

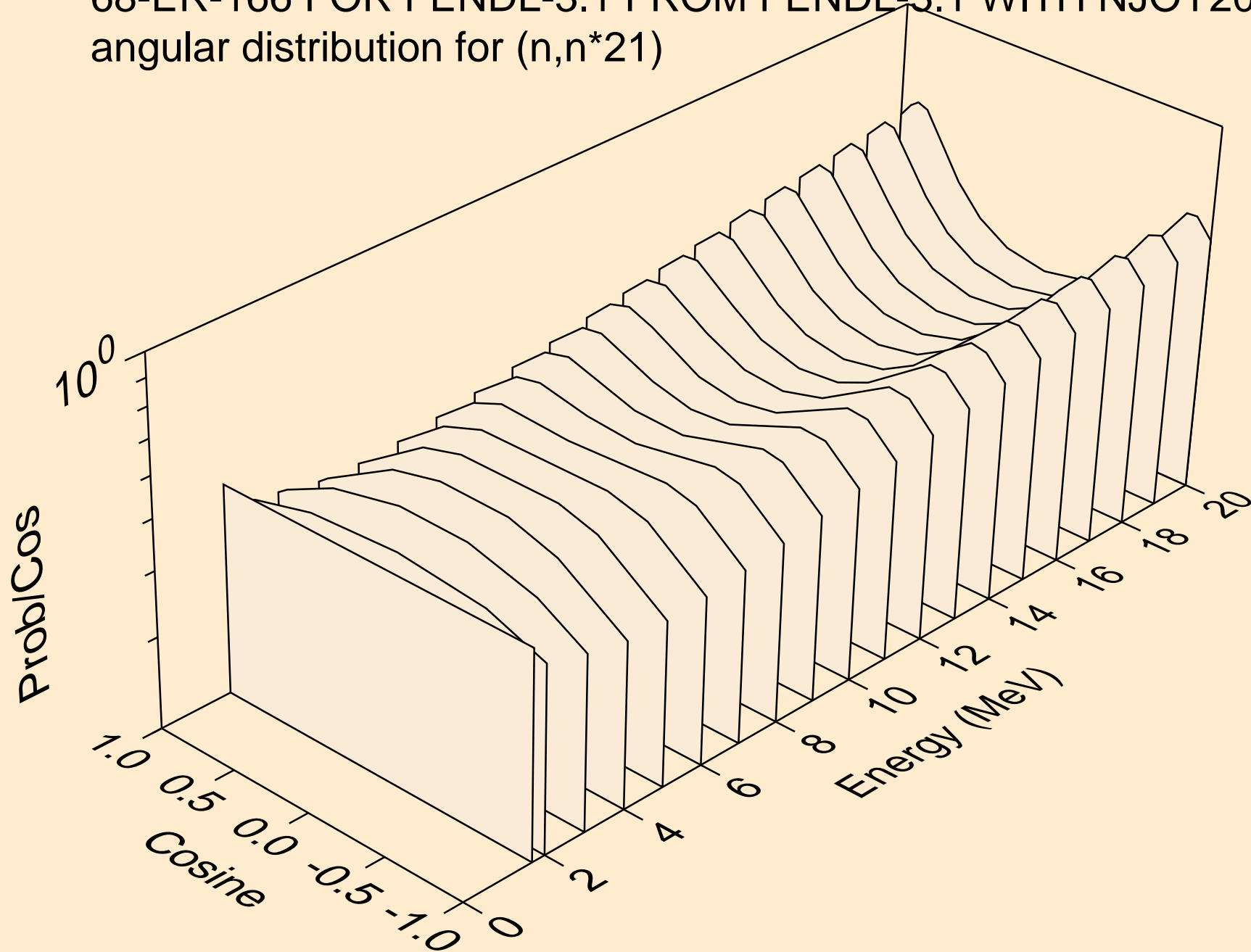

68-ER-166 FOR FENDL-3.1 FROM FENDL-3.1 WITH NJOY2012.50
angular distribution for (n,n*22)

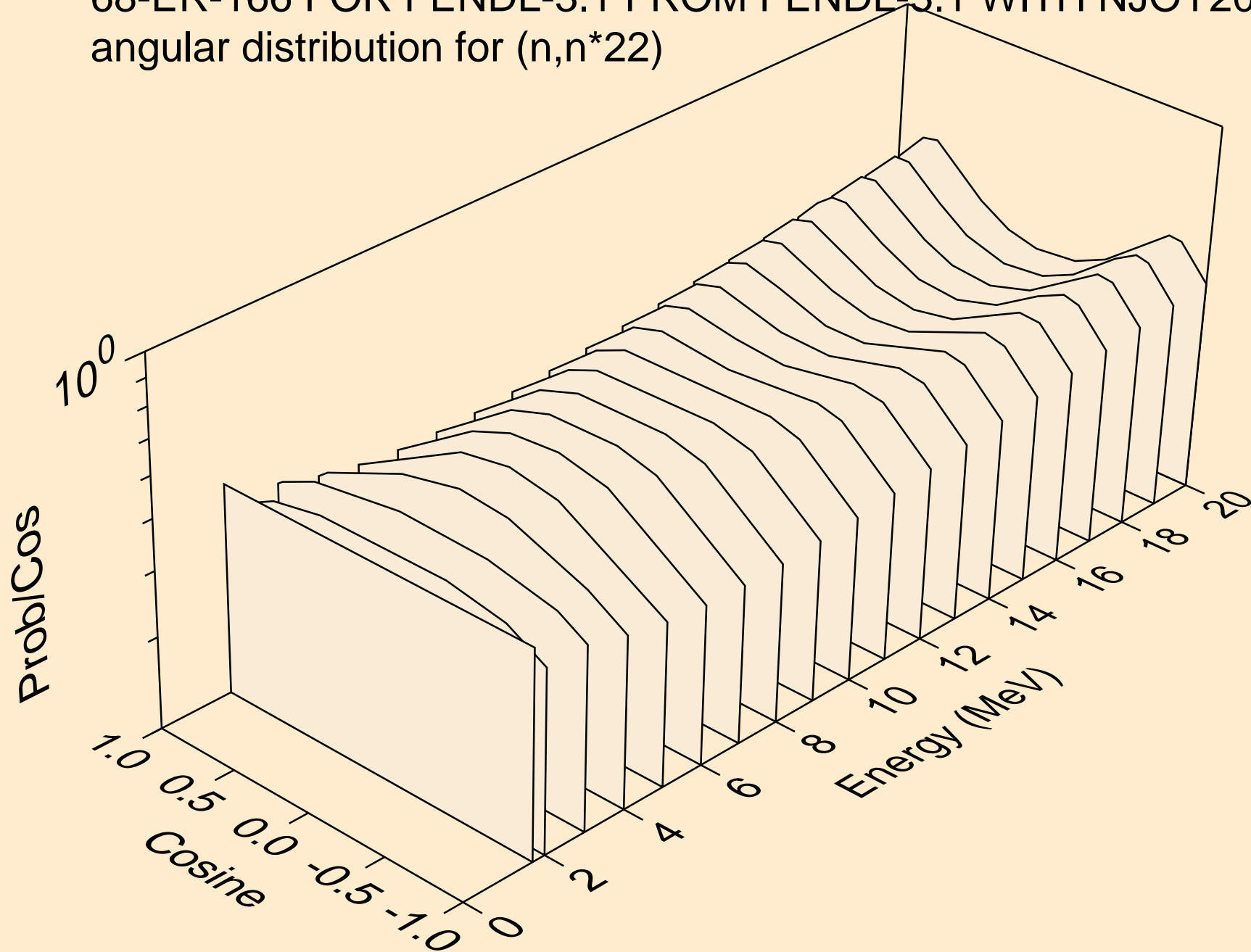

68-ER-166 FOR FENDL-3.1 FROM FENDL-3.1 WITH NJOY2012.50
angular distribution for (n,n*23)

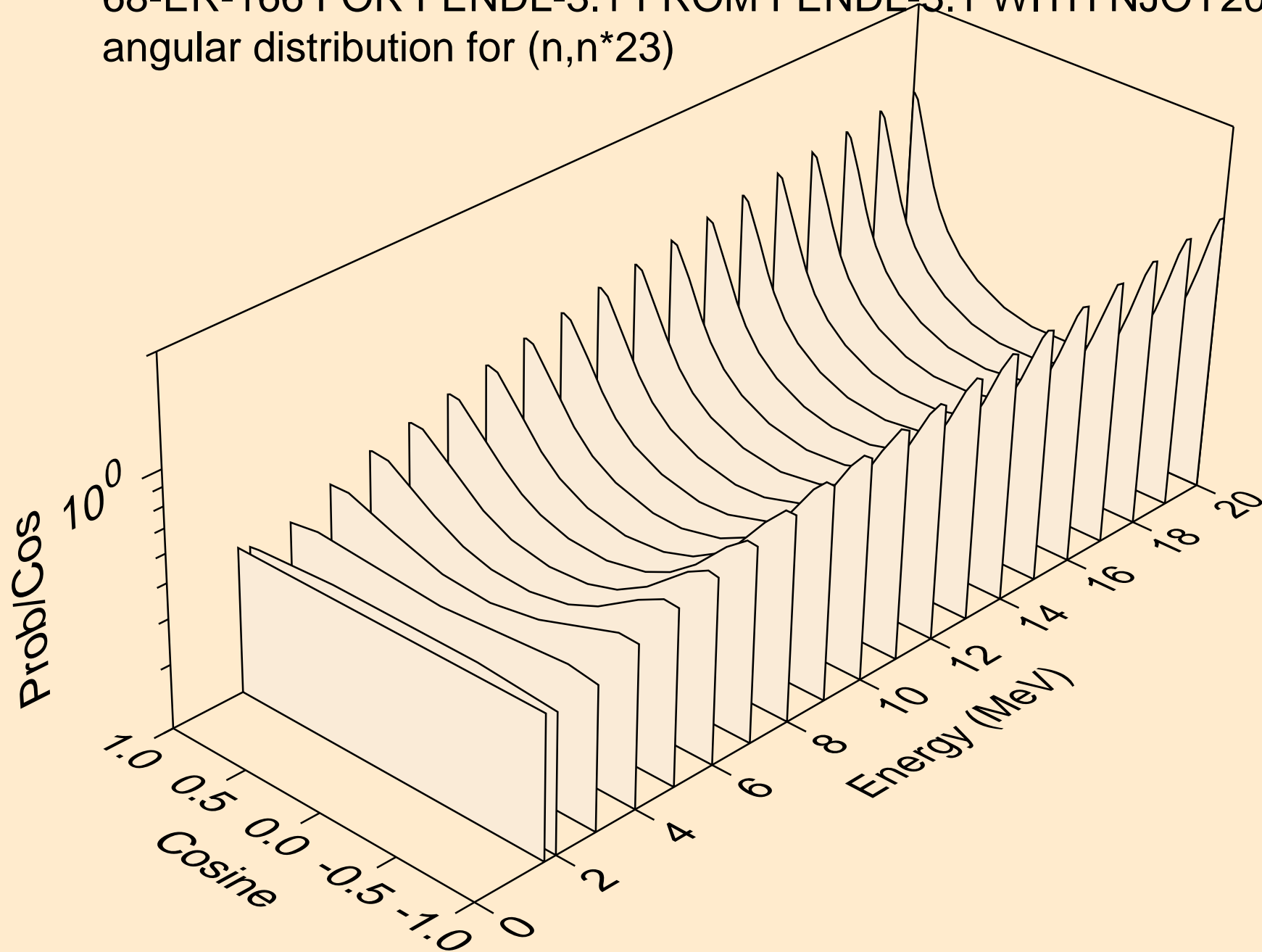

68-ER-166 FOR FENDL-3.1 FROM FENDL-3.1 WITH NJOY2012.50
angular distribution for (n,n*24)

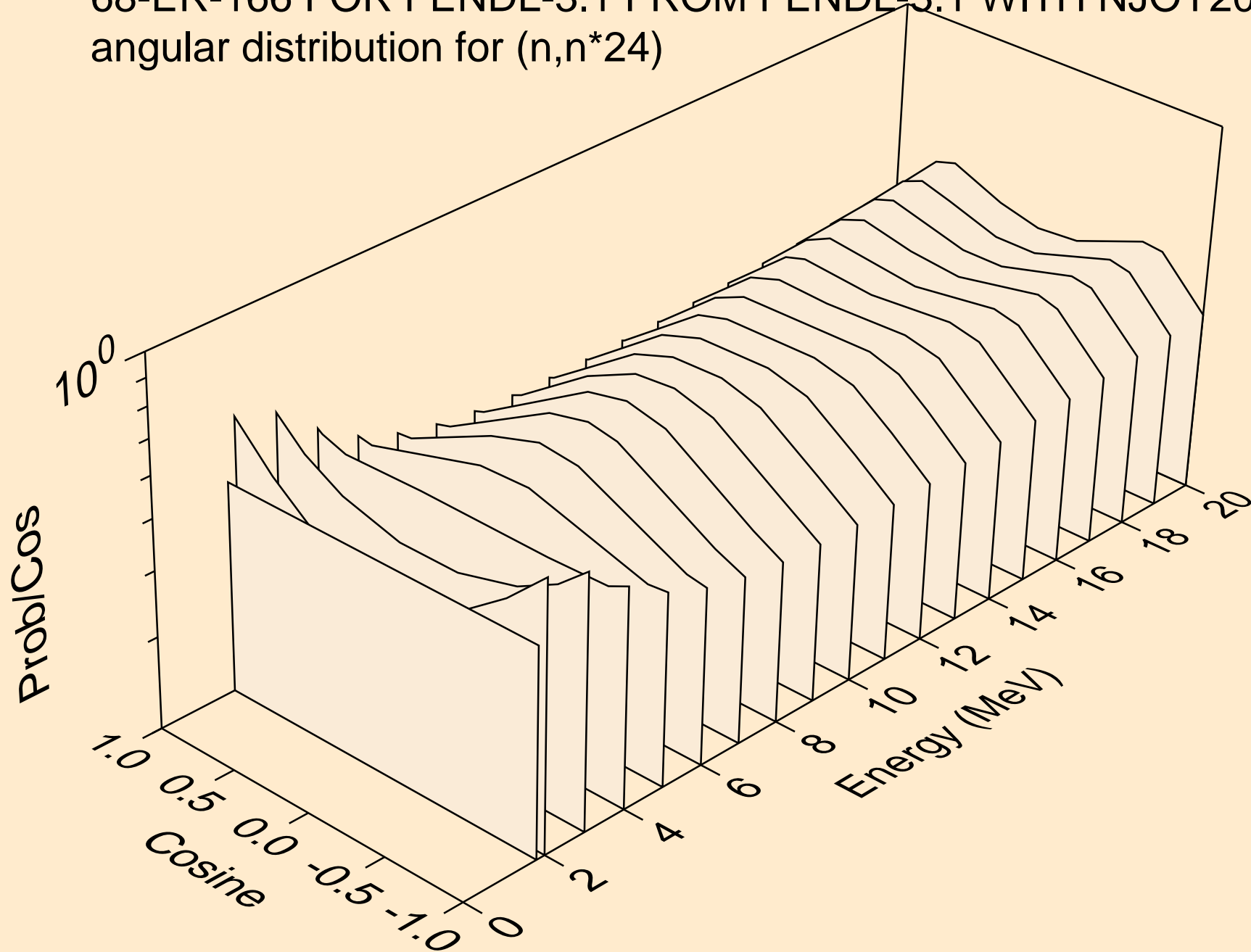

68-ER-166 FOR FENDL-3.1 FROM FENDL-3.1 WITH NJOY2012.50
angular distribution for (n,n*c)

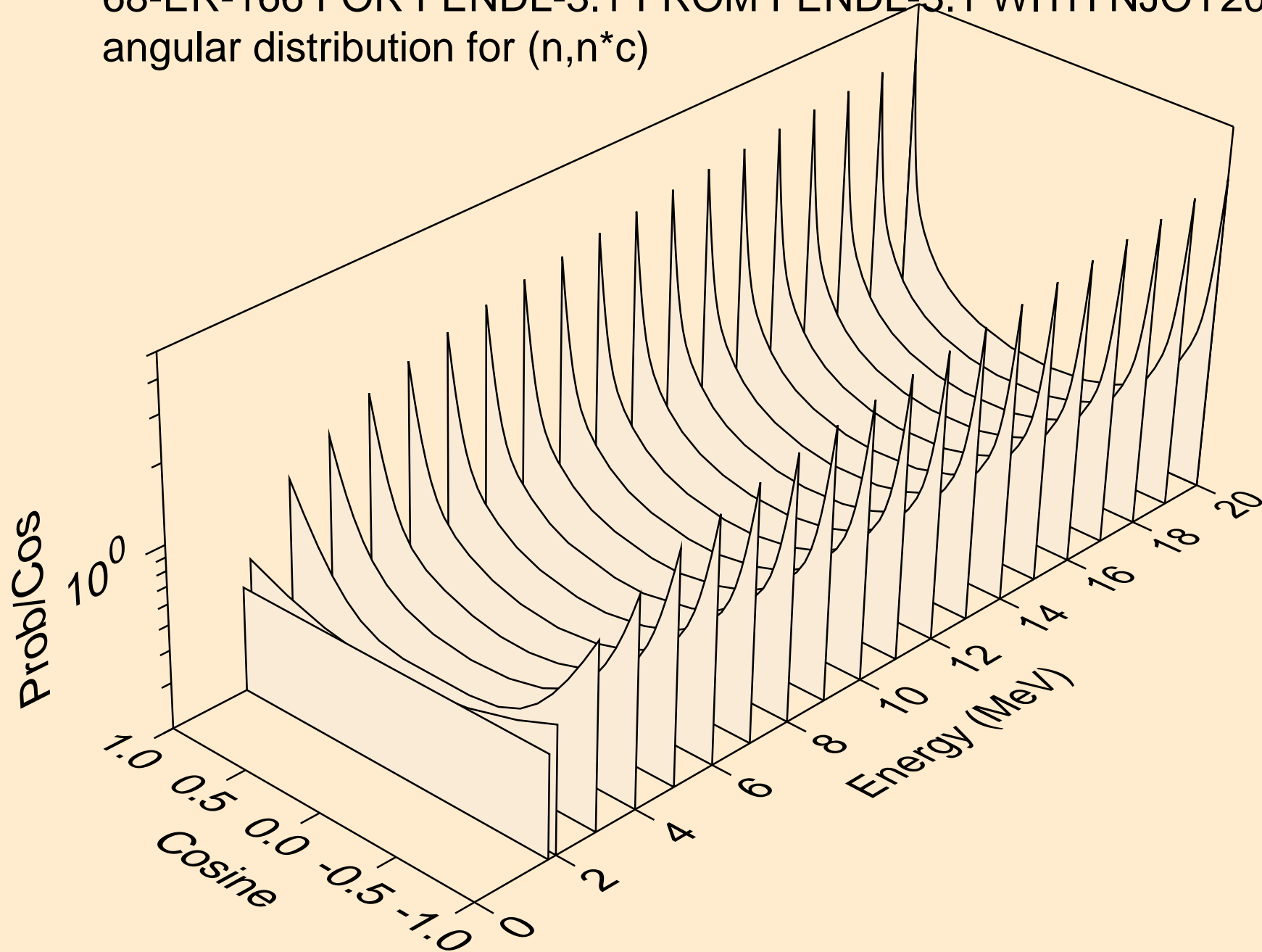

68-ER-166 FOR FENDL-3.1 FROM FENDL-3.1 WITH NJOY2012.50
Neutron emission for (n,x)

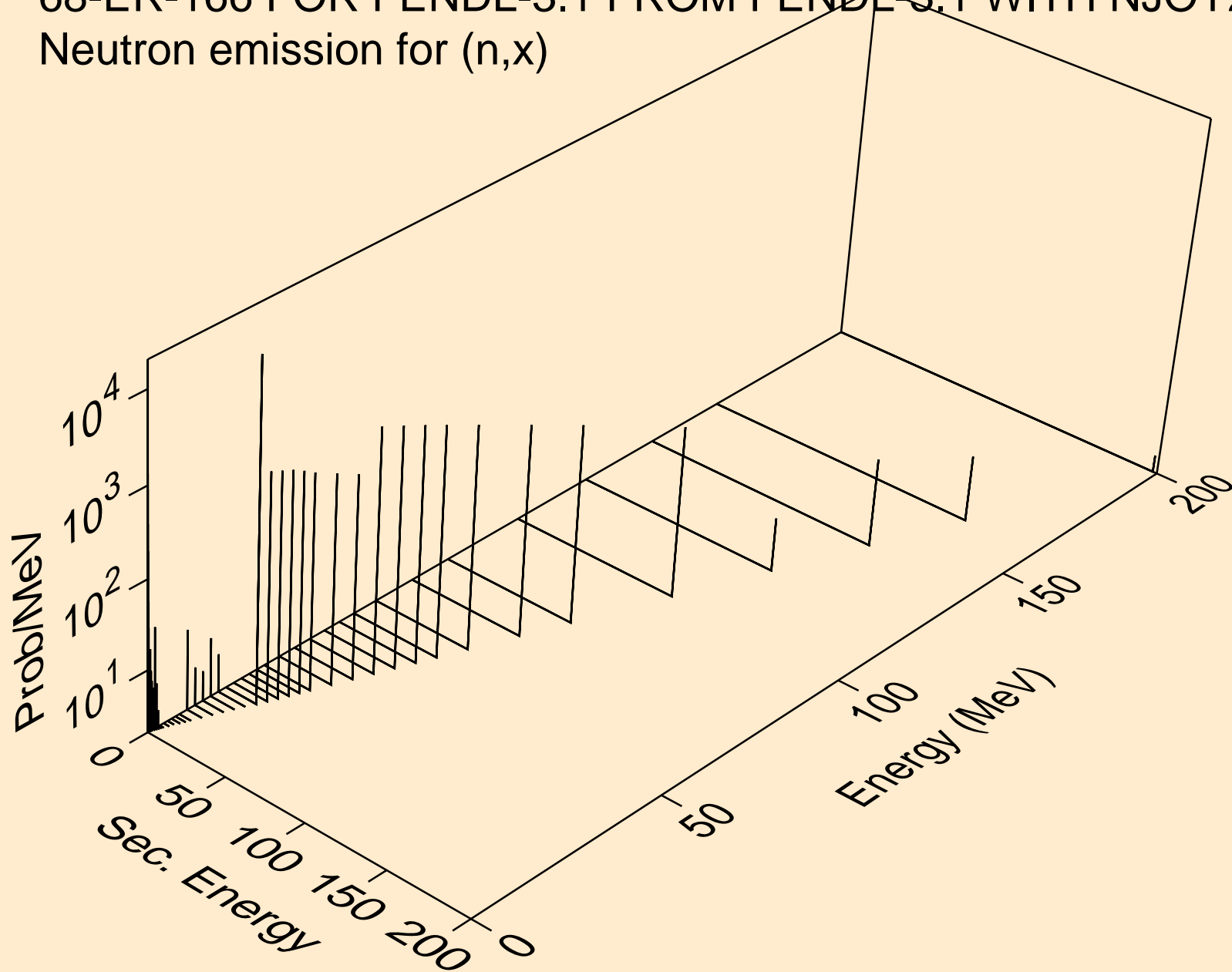

68-ER-166 FOR FENDL-3.1 FROM FENDL-3.1 WITH NJOY2012.50
Neutron emission for (n,2n)

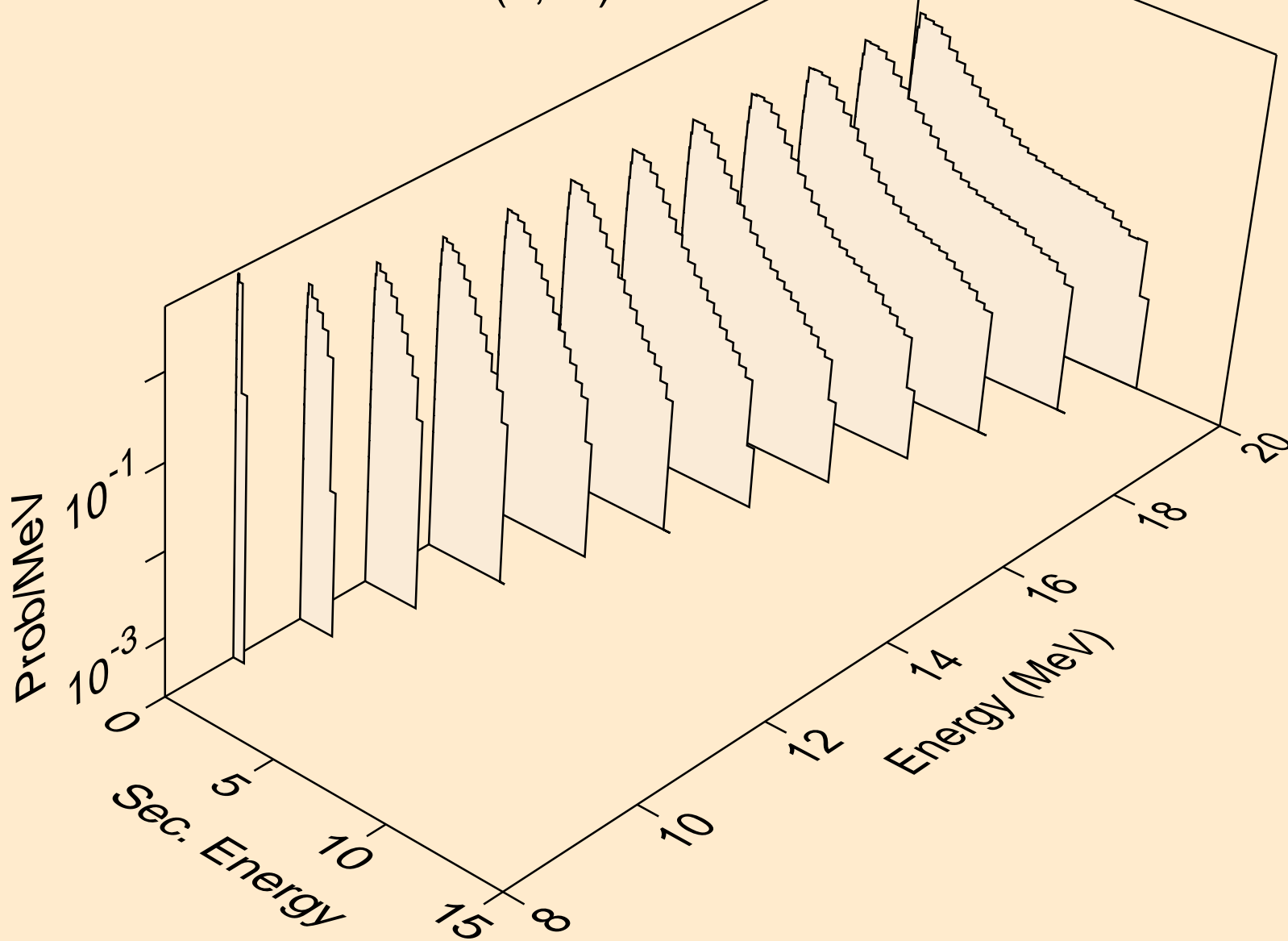

68-ER-166 FOR FENDL-3.1 FROM FENDL-3.1 WITH NJOY2012.50
Neutron emission for (n,3n)

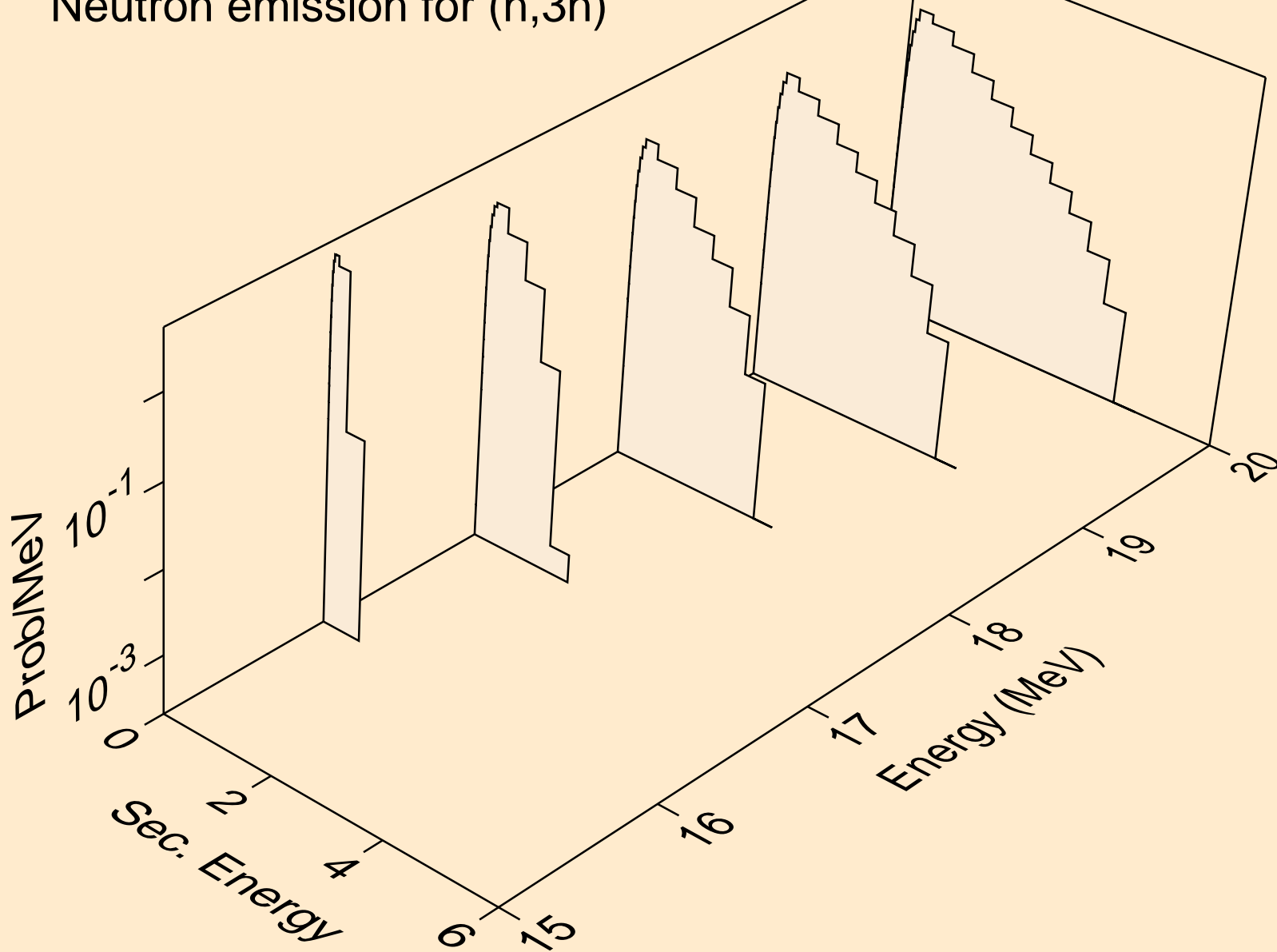

68-ER-166 FOR FENDL-3.1 FROM FENDL-3.1 WITH NJOY2012.50
Neutron emission for (n,n*)a

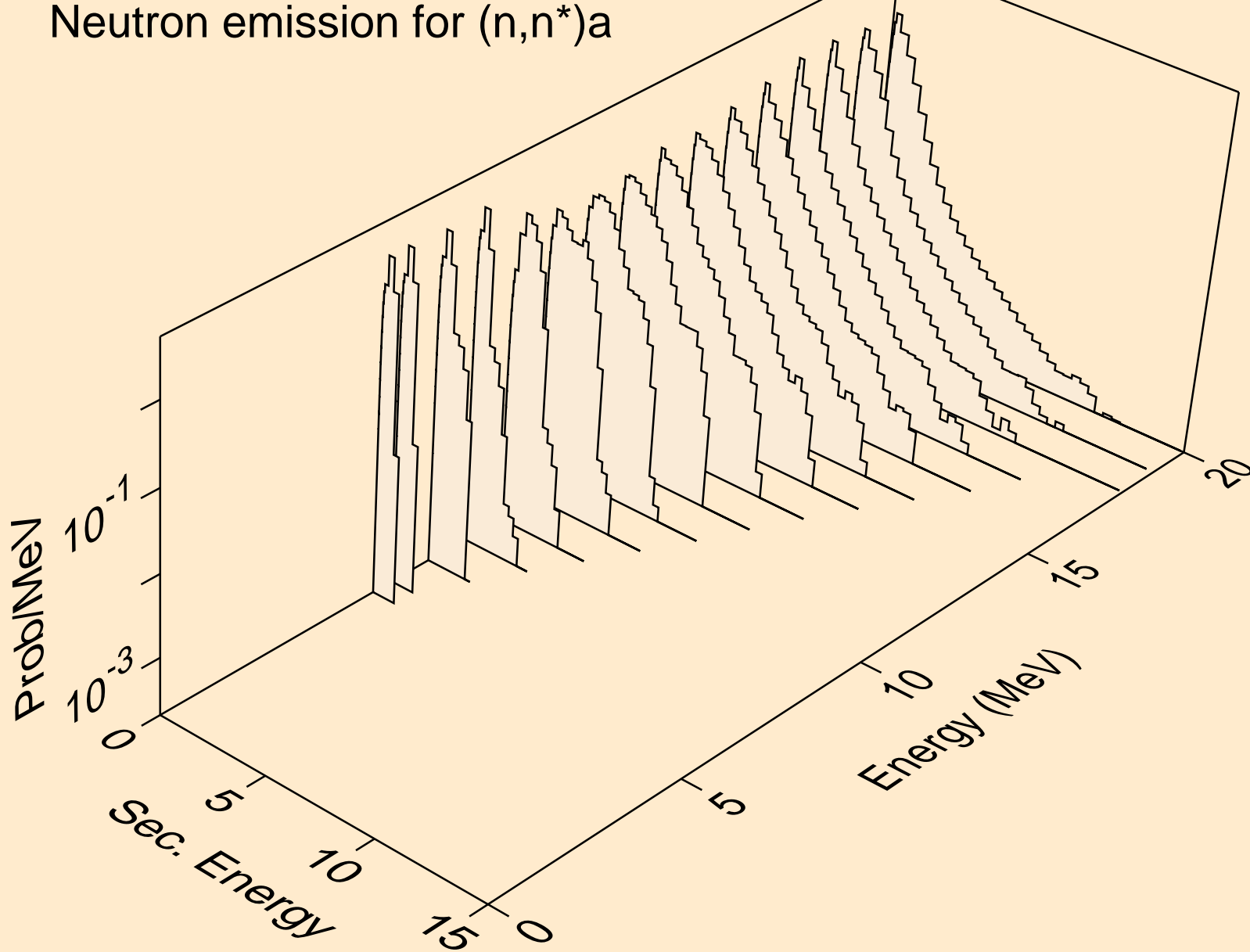

68-ER-166 FOR FENDL-3.1 FROM FENDL-3.1 WITH NJOY2012.50
Neutron emission for (n,n*)p

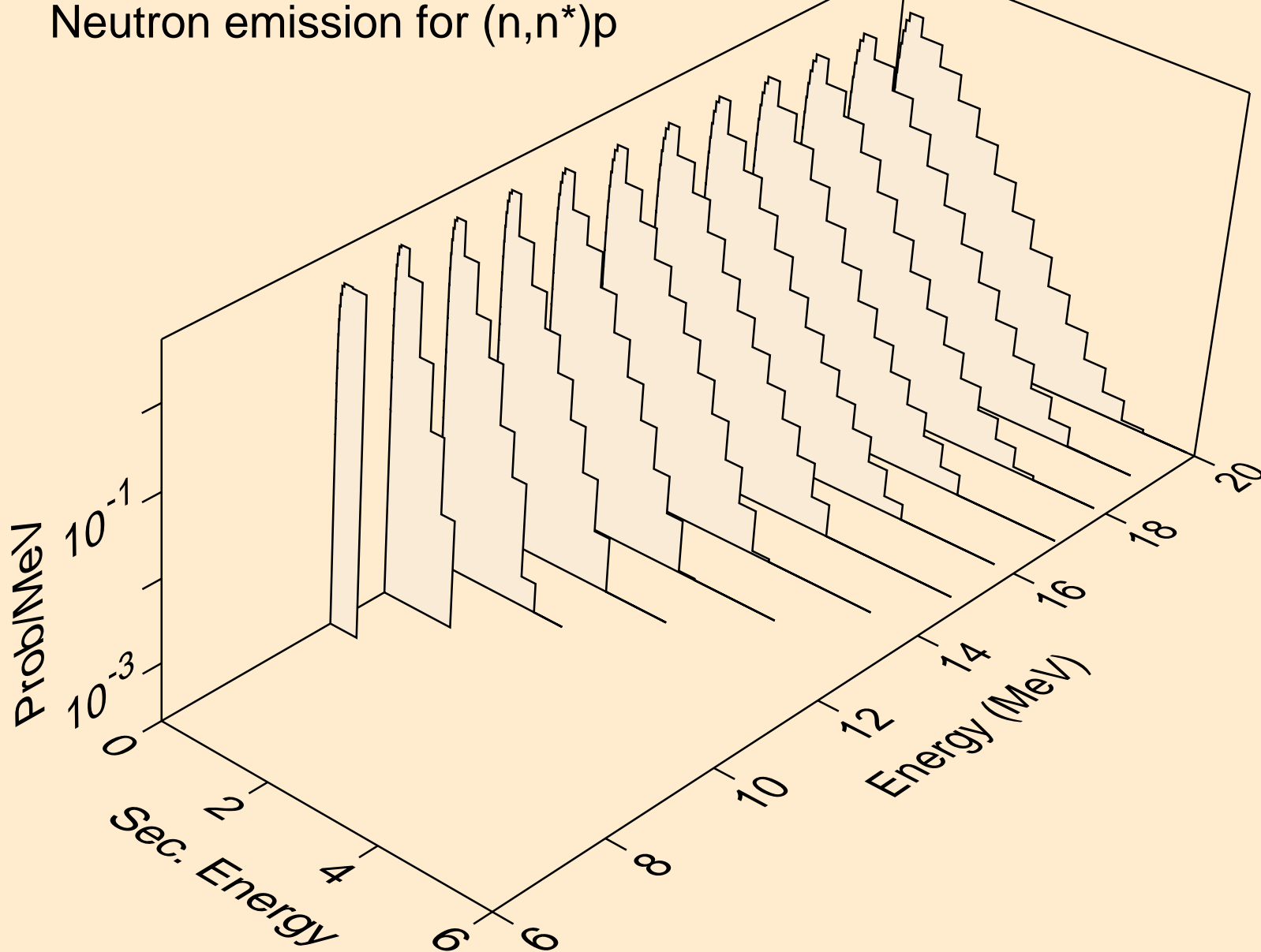

68-ER-166 FOR FENDL-3.1 FROM FENDL-3.1 WITH NJOY2012.50
Neutron emission for (n,n*)d

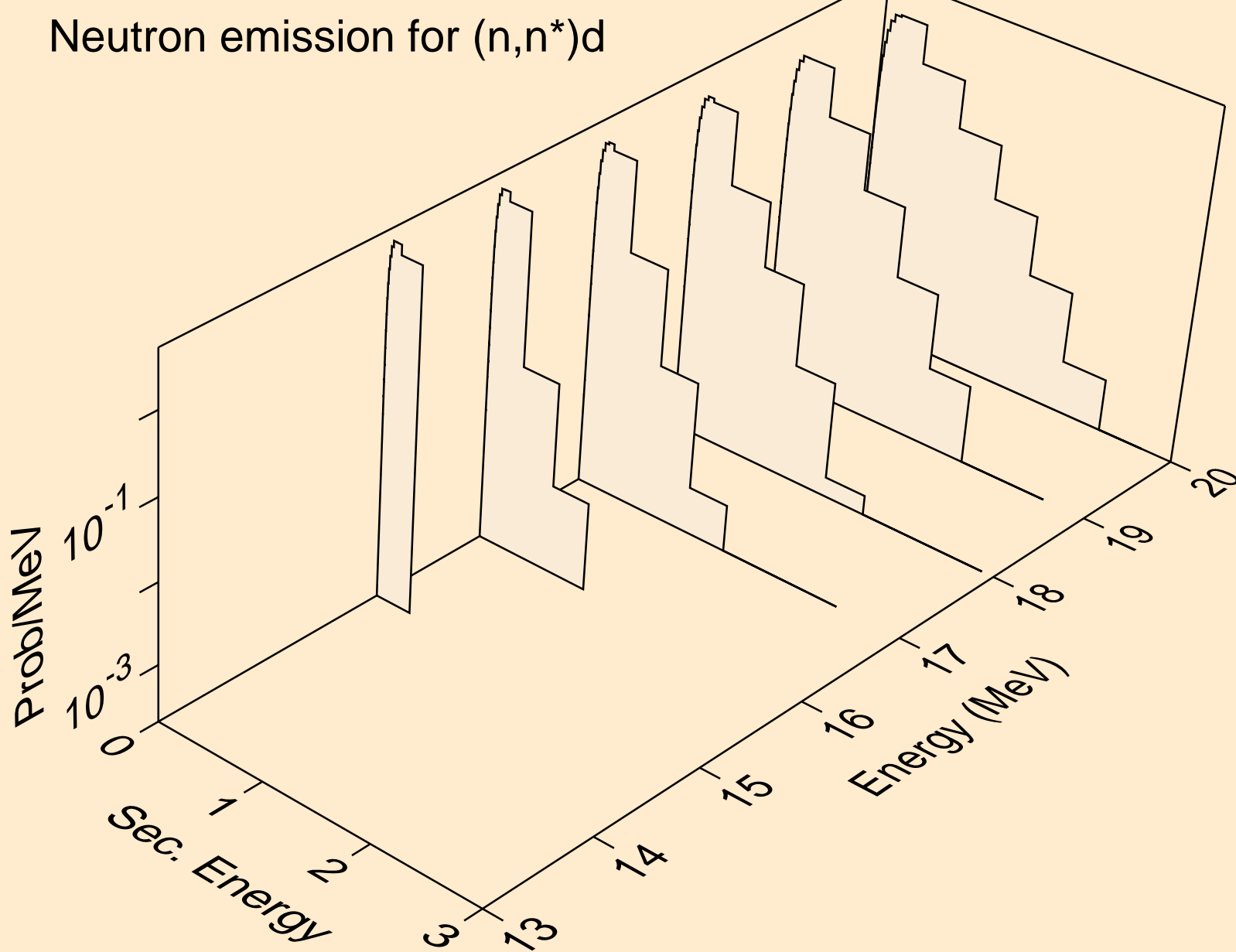

68-ER-166 FOR FENDL-3.1 FROM FENDL-3.1 WITH NJOY2012.50
Neutron emission for (n,n*c)

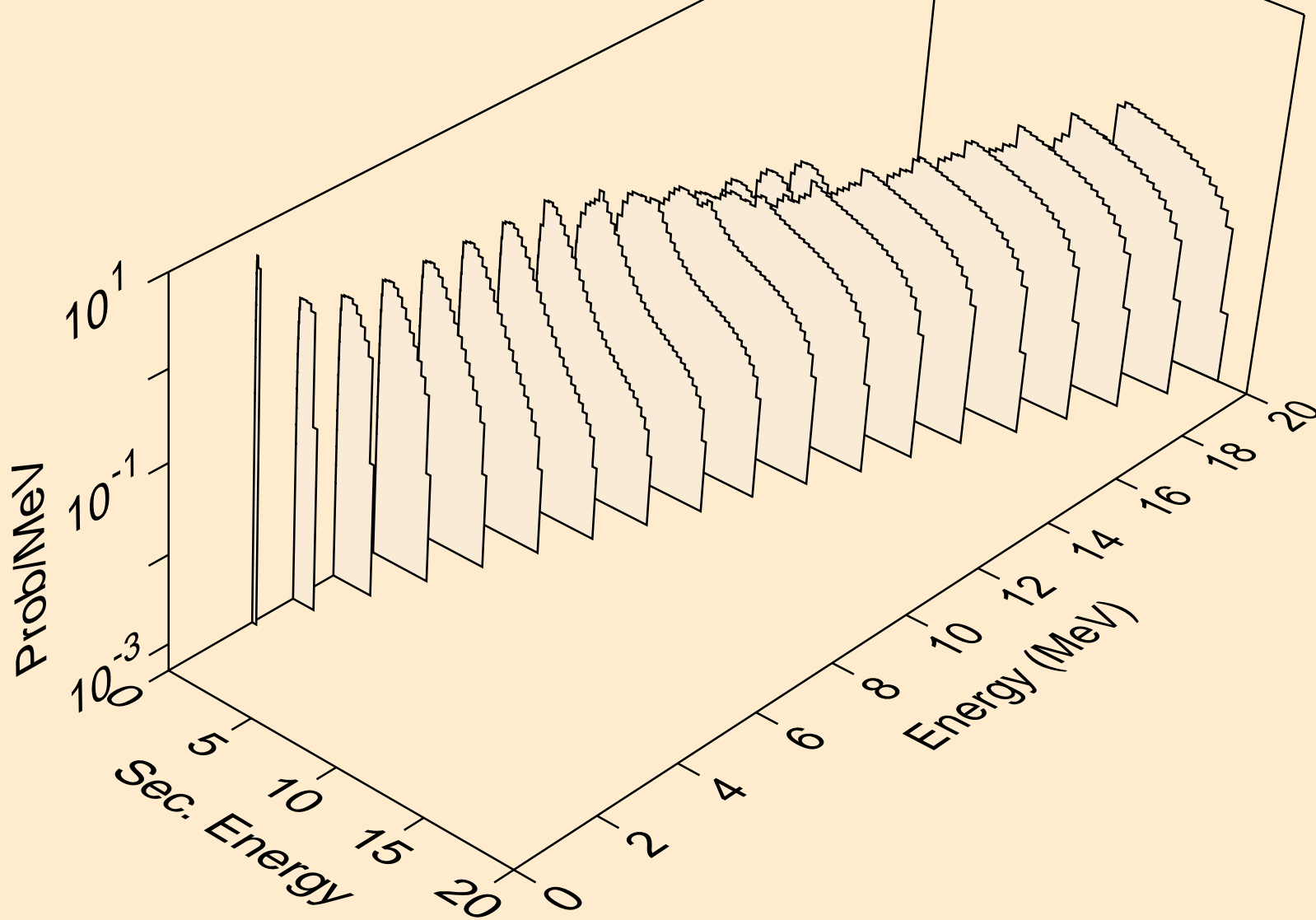

68-ER-166 FOR FENDL-3.1 FROM FENDL-3.1 WITH NJOY2012.50
Photon emission for (n,2n)

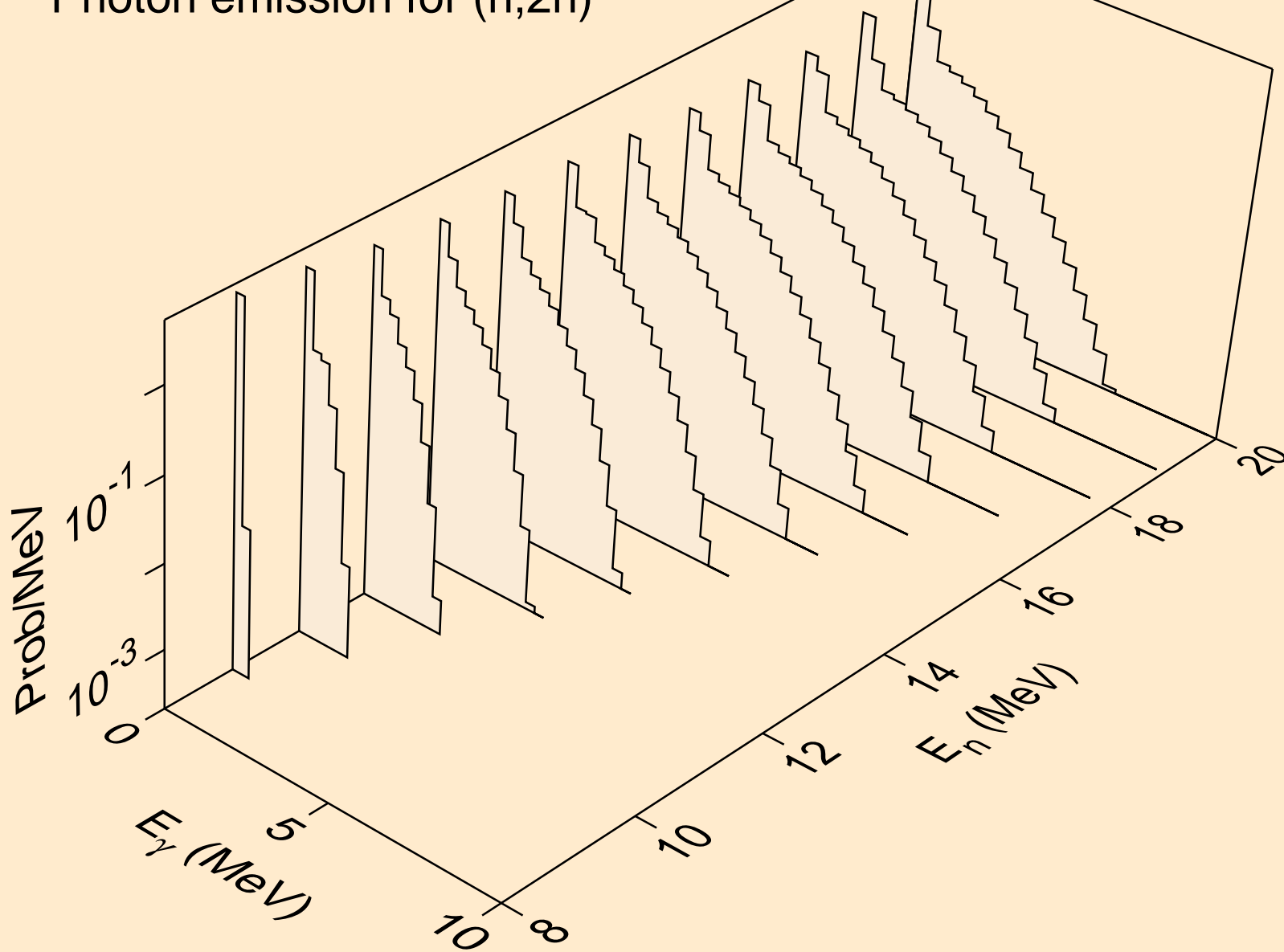

68-ER-166 FOR FENDL-3.1 FROM FENDL-3.1 WITH NJOY2012.50
Photon emission for (n,3n)

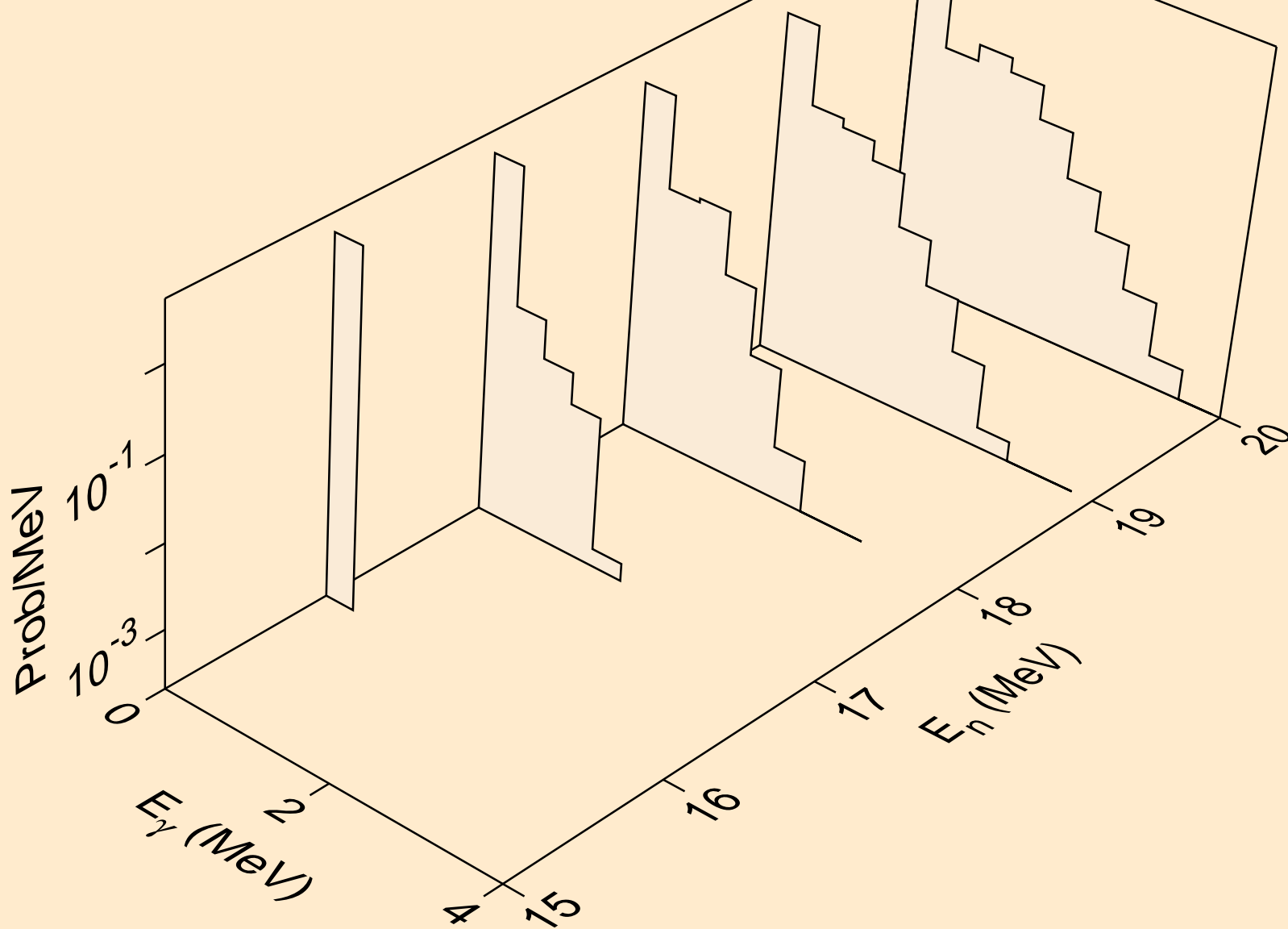

68-ER-166 FOR FENDL-3.1 FROM FENDL-3.1 WITH NJOY2012.50
Photon emission for (n,n*)a

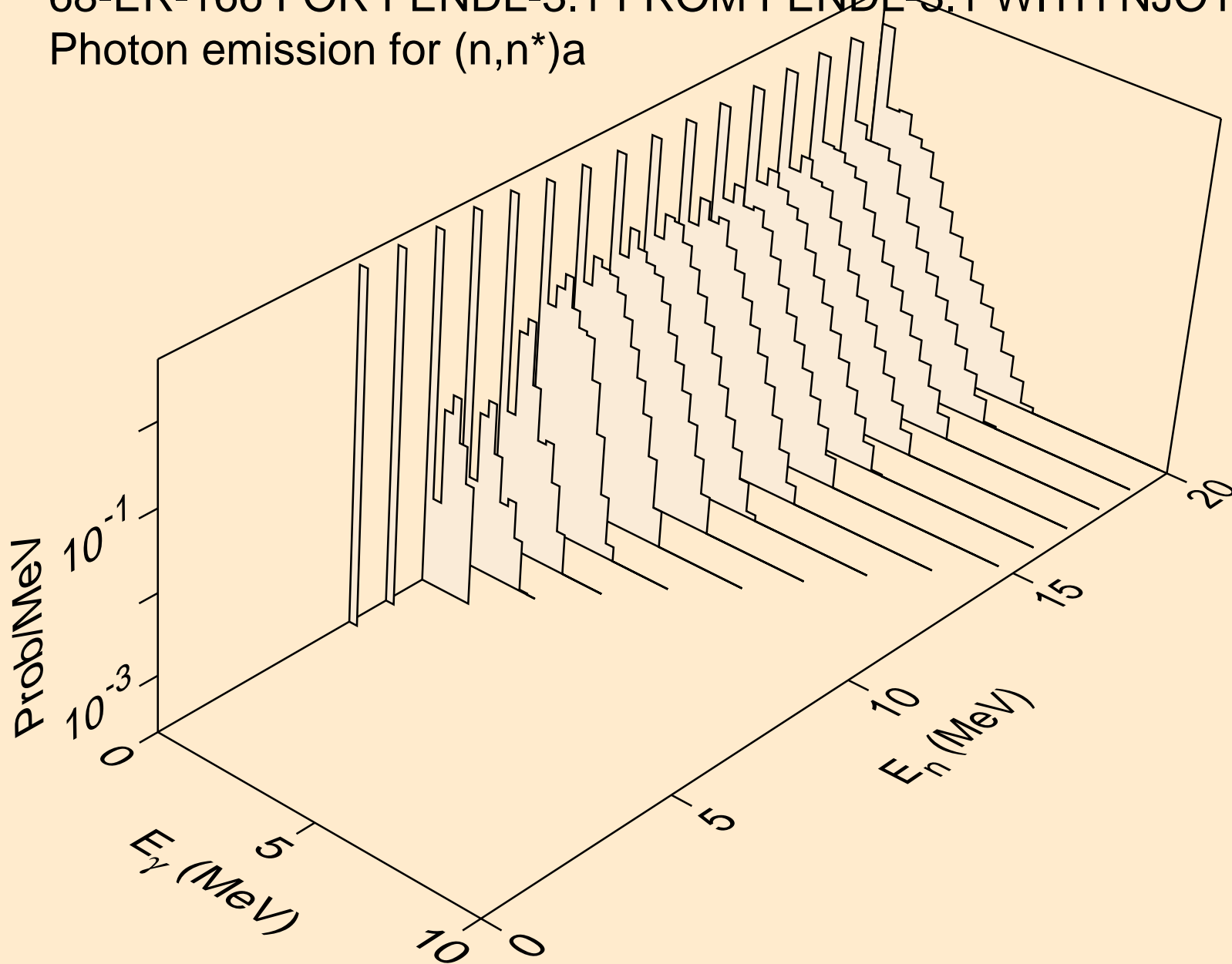

68-ER-166 FOR FENDL-3.1 FROM FENDL-3.1 WITH NJOY2012.50
Photon emission for (n,n*)p

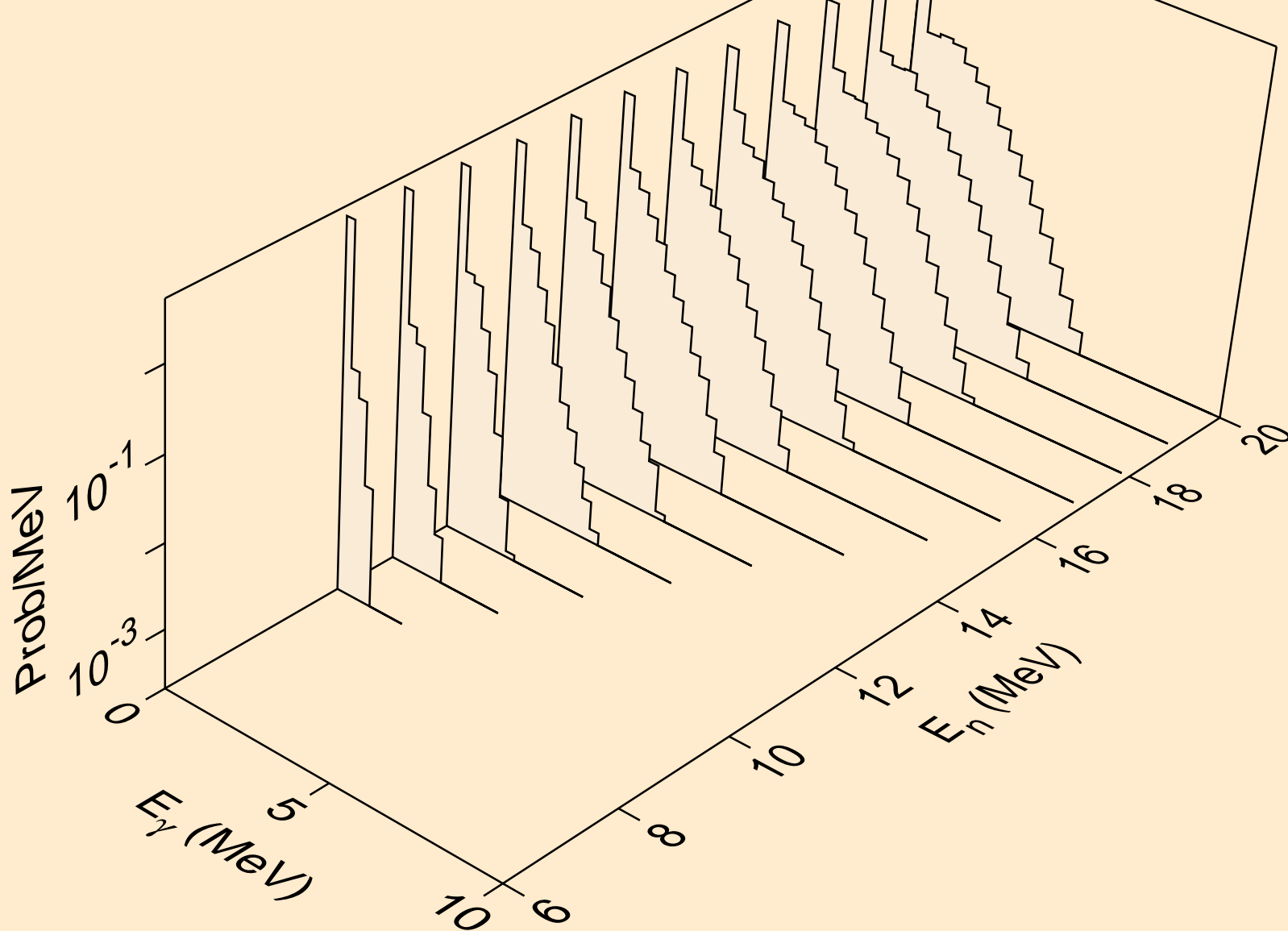

68-ER-166 FOR FENDL-3.1 FROM FENDL-3.1 WITH NJOY2012.50
Photon emission for (n,n*c)

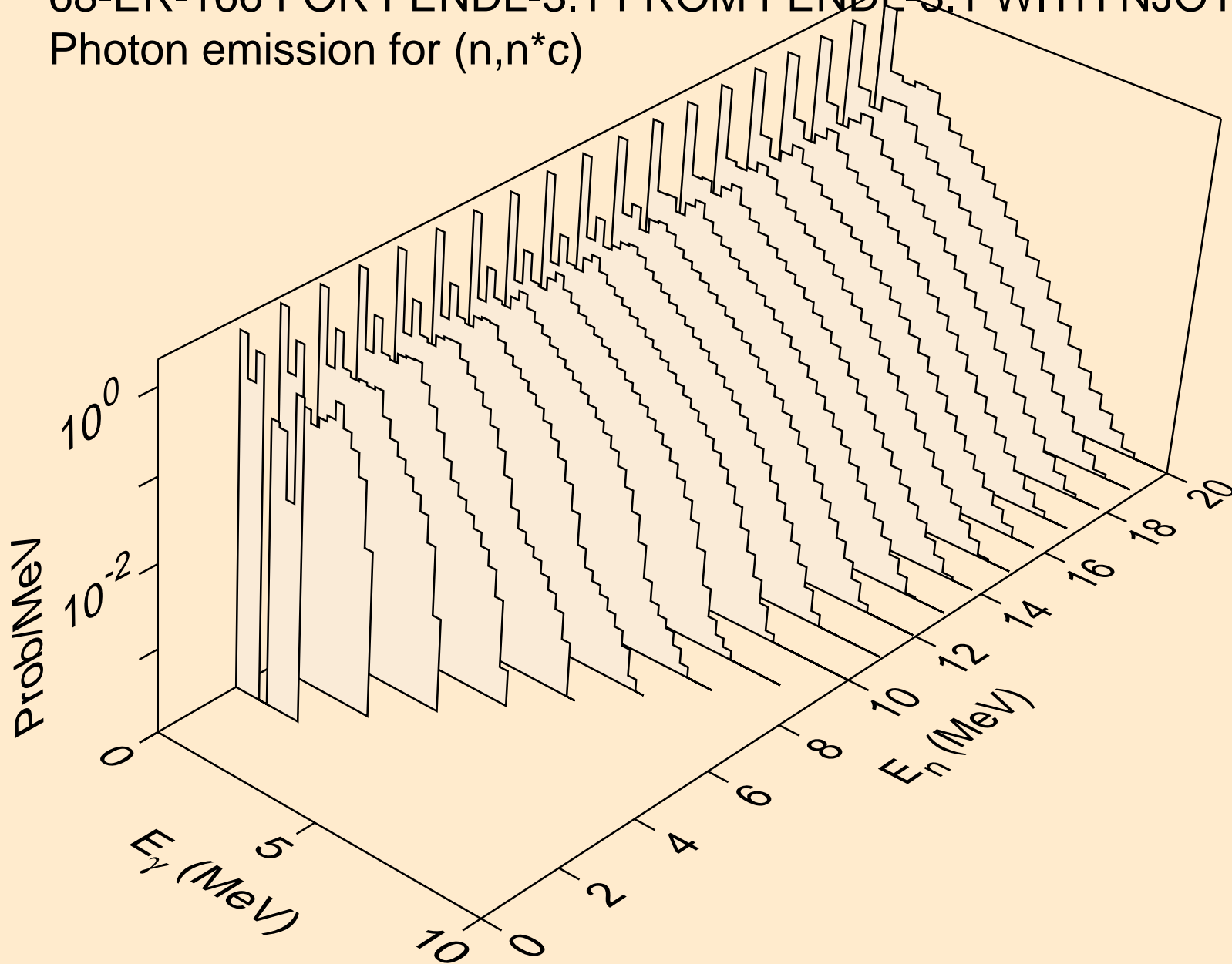

68-ER-166 FOR FENDL-3.1 FROM FENDL-3.1 WITH NJOY2012.50
Photon emission for (n,gma)

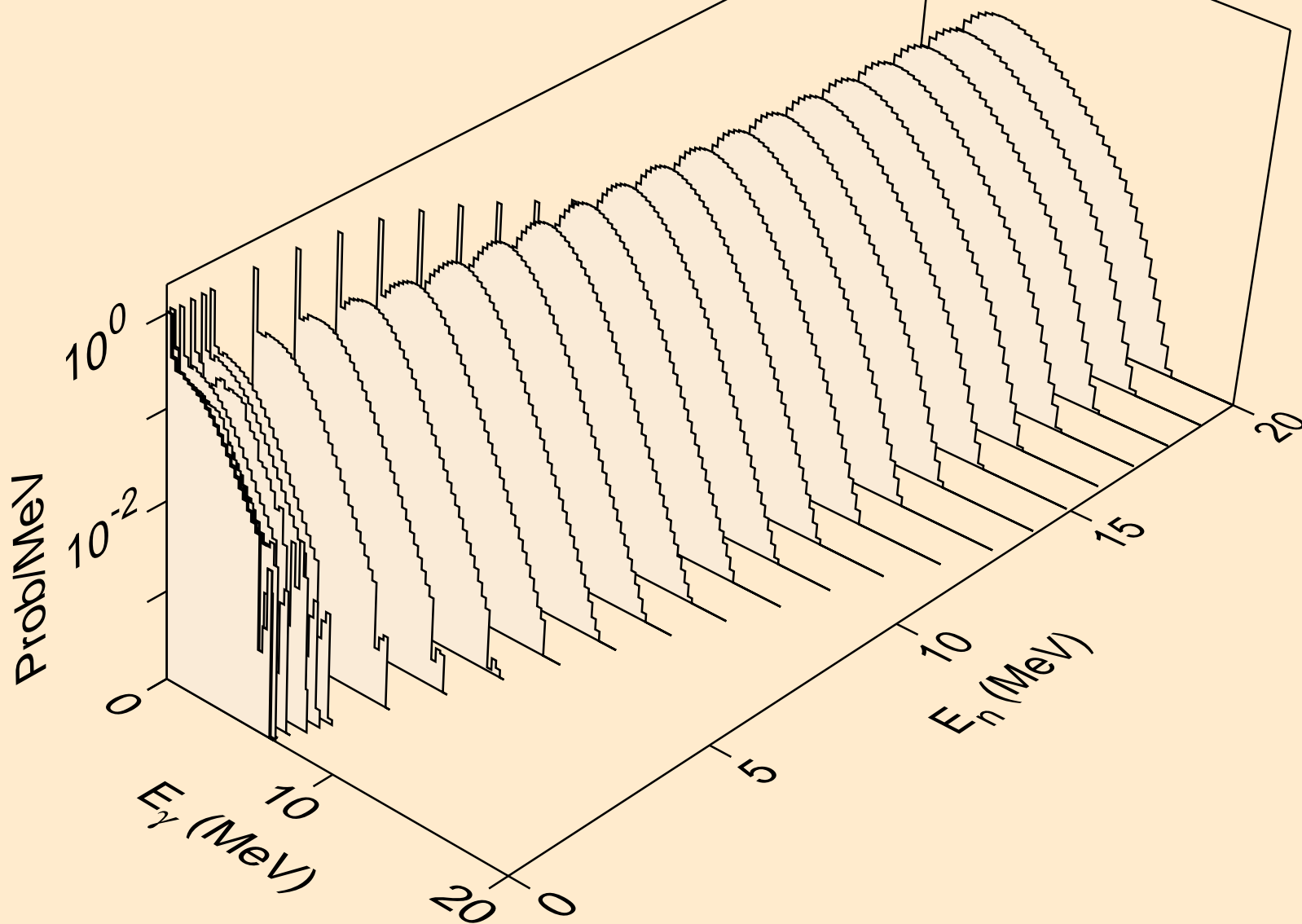

68-ER-166 FOR FENDL-3.1 FROM FENDL-3.1 WITH NJOY2012.50
Photon emission for (n,p)

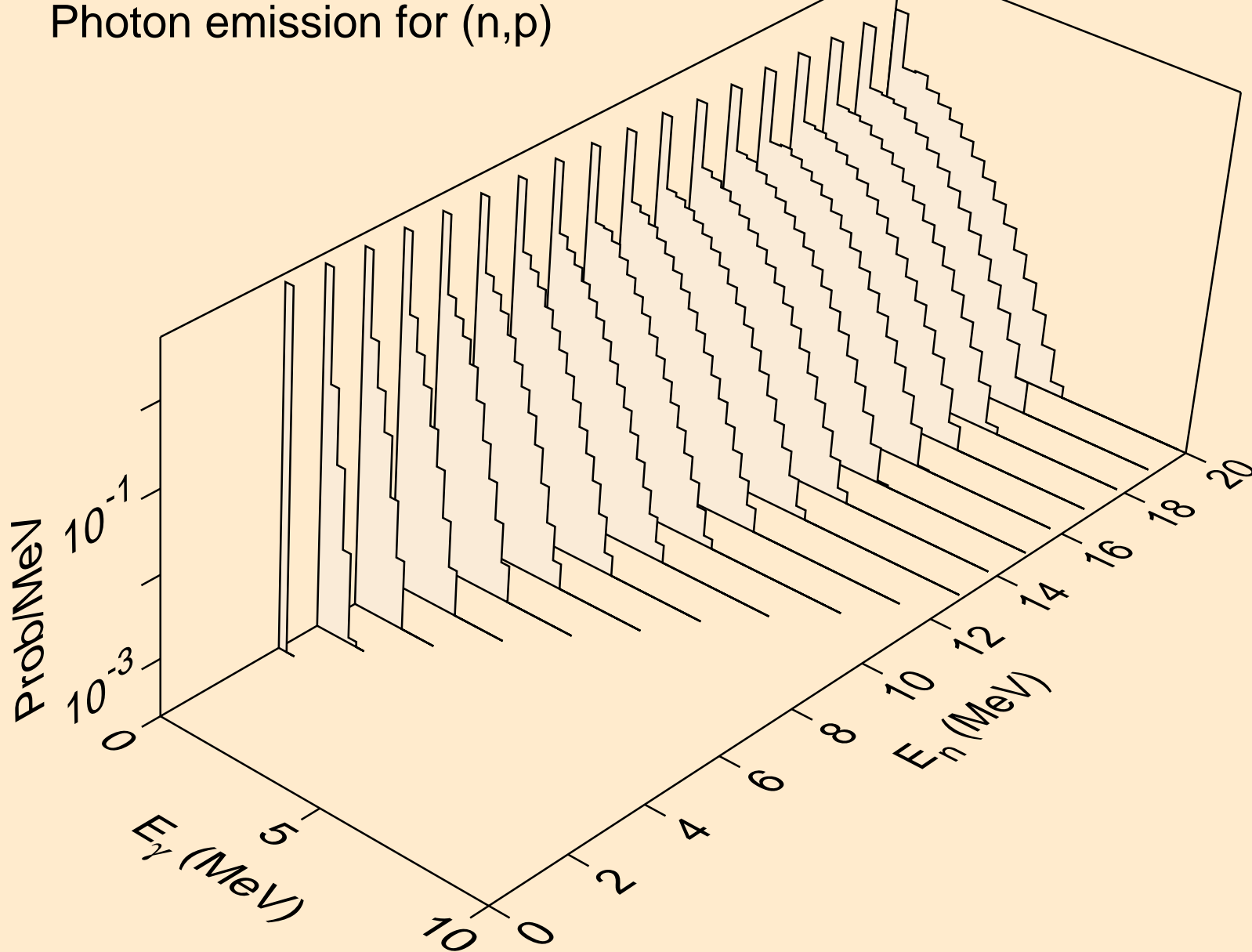

68-ER-166 FOR FENDL-3.1 FROM FENDL-3.1 WITH NJOY2012.50
Photon emission for (n,d)

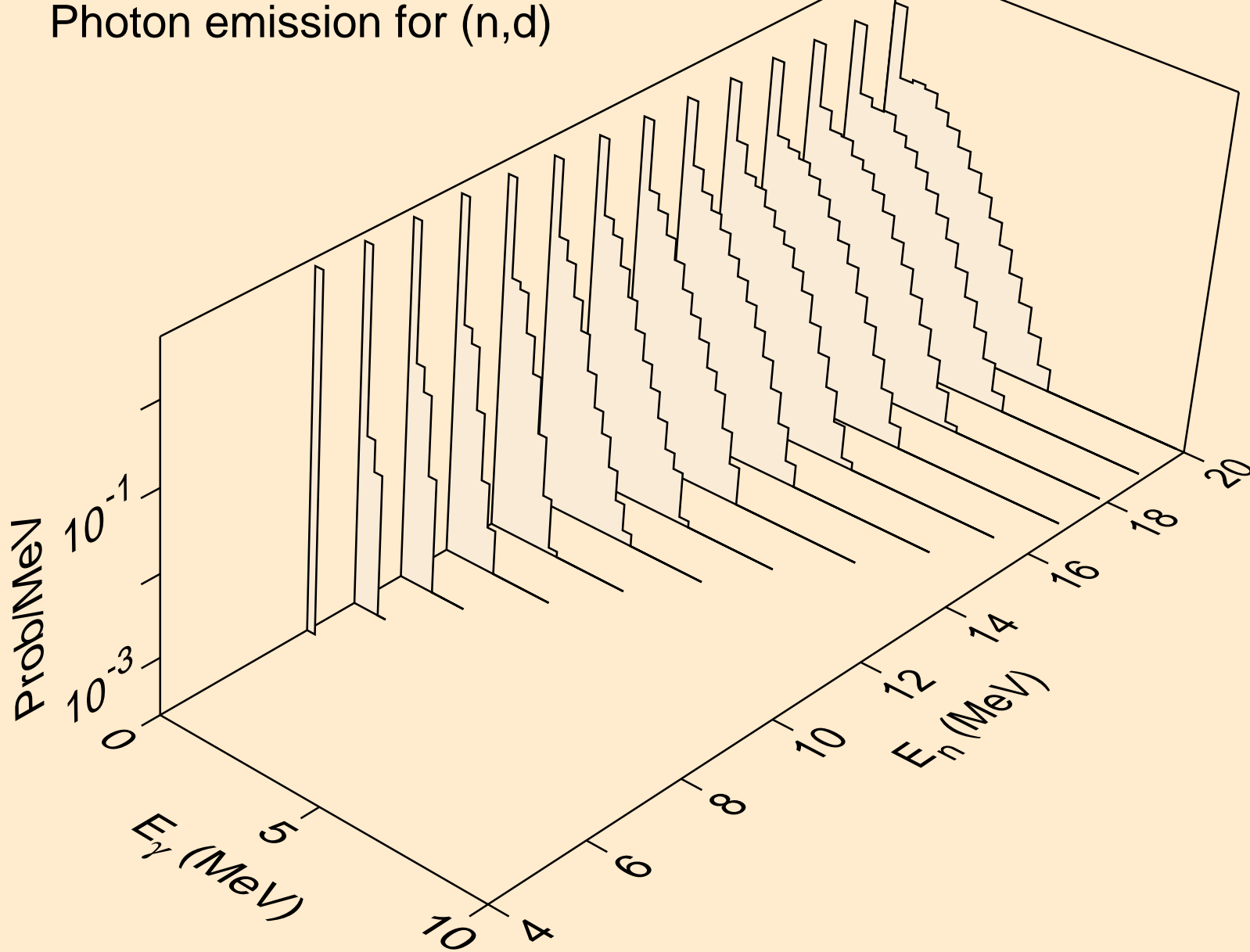

68-ER-166 FOR FENDL-3.1 FROM FENDL-3.1 WITH NJOY2012.50
Photon emission for (n,a)

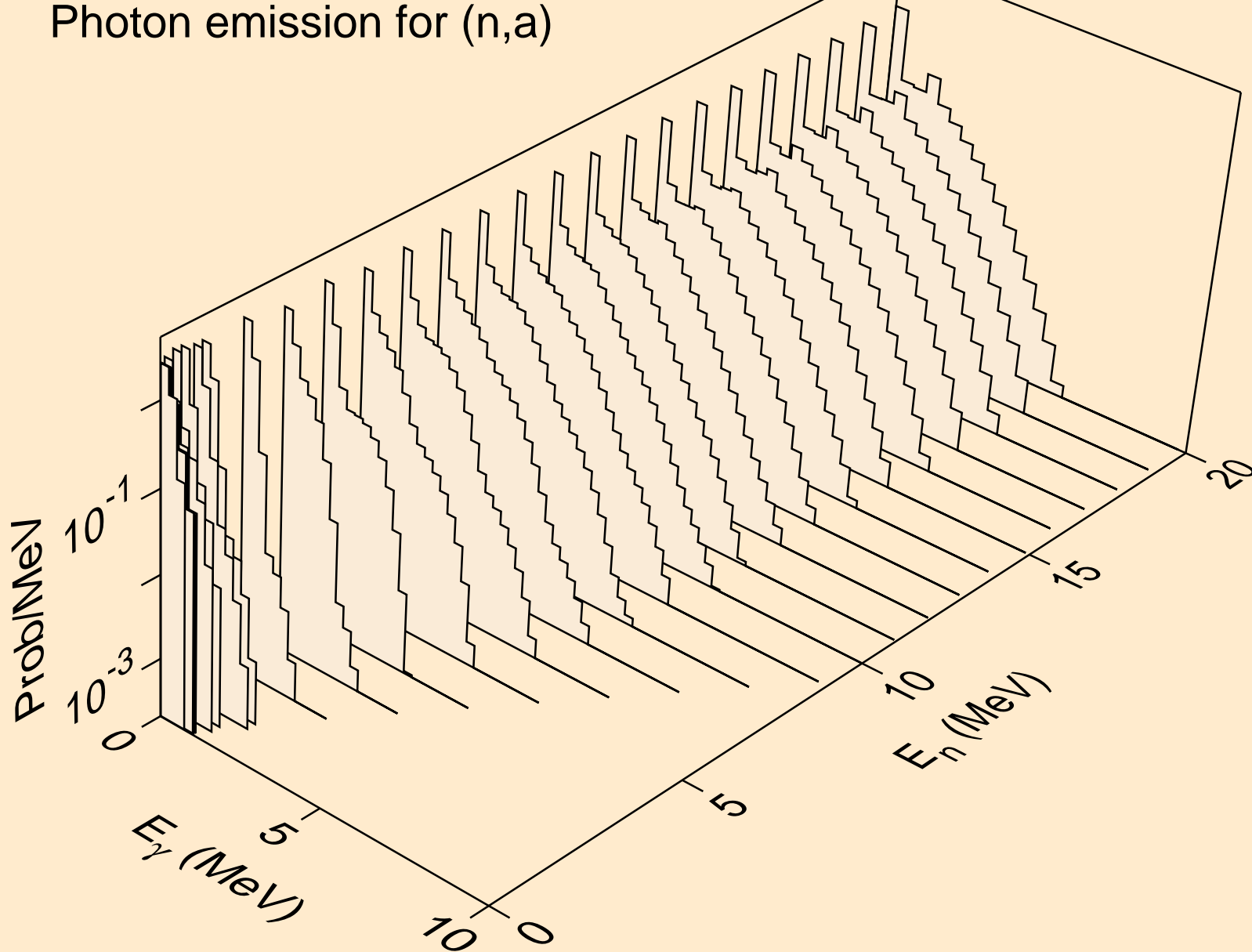

68-ER-166 FOR FENDL-3.1 FROM FENDL-3.1 WITH NJOY2012.50
Photon emission for (n,x)

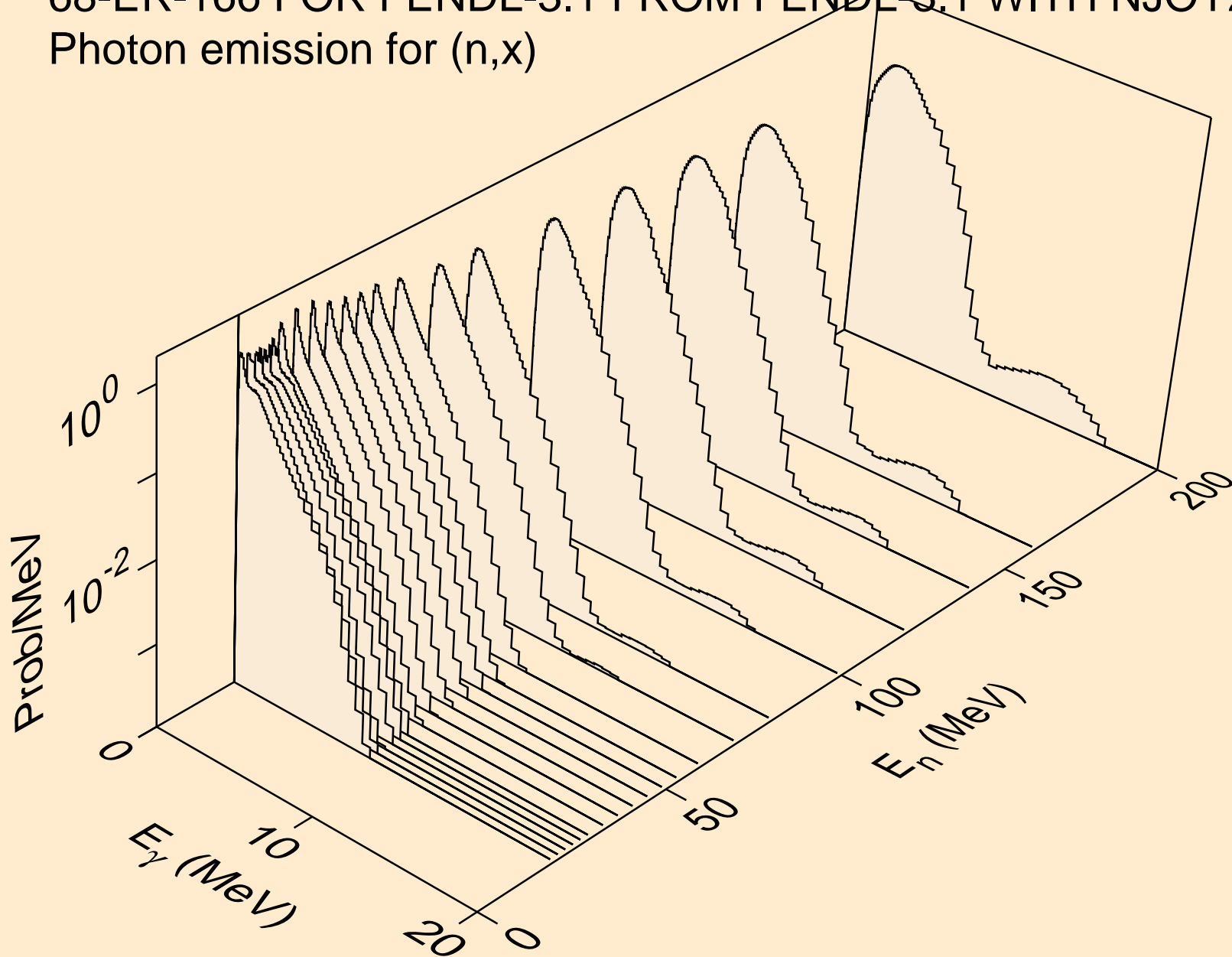

68-ER-166 FOR FENDL-3.1 FROM FENDL-3.1 WITH NJOY2012.50
thermal capture photon spectrum

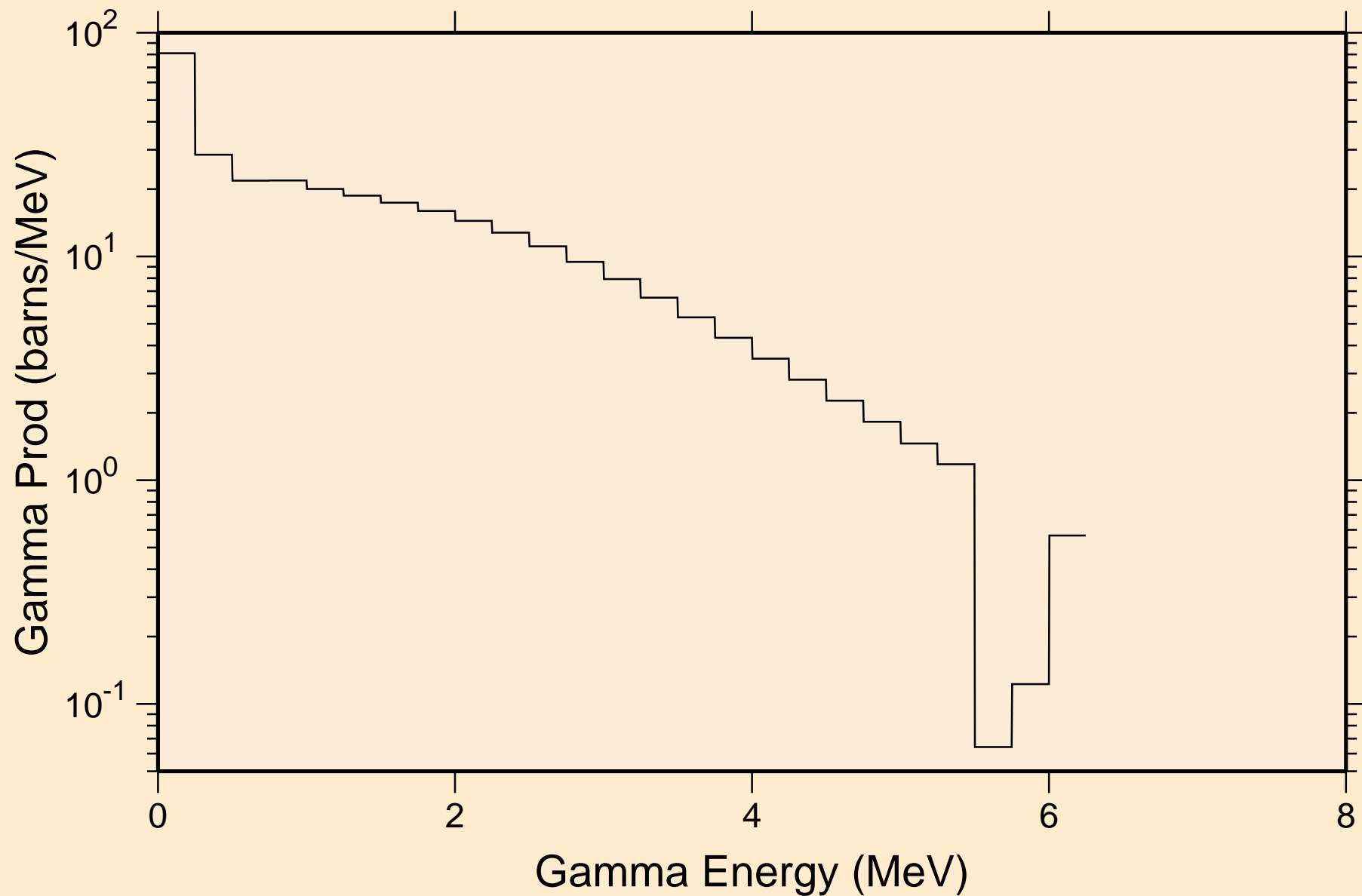

68-ER-166 FOR FENDL-3.1 FROM FENDL-3.1 WITH NJOY2012.50
14 MeV photon spectrum

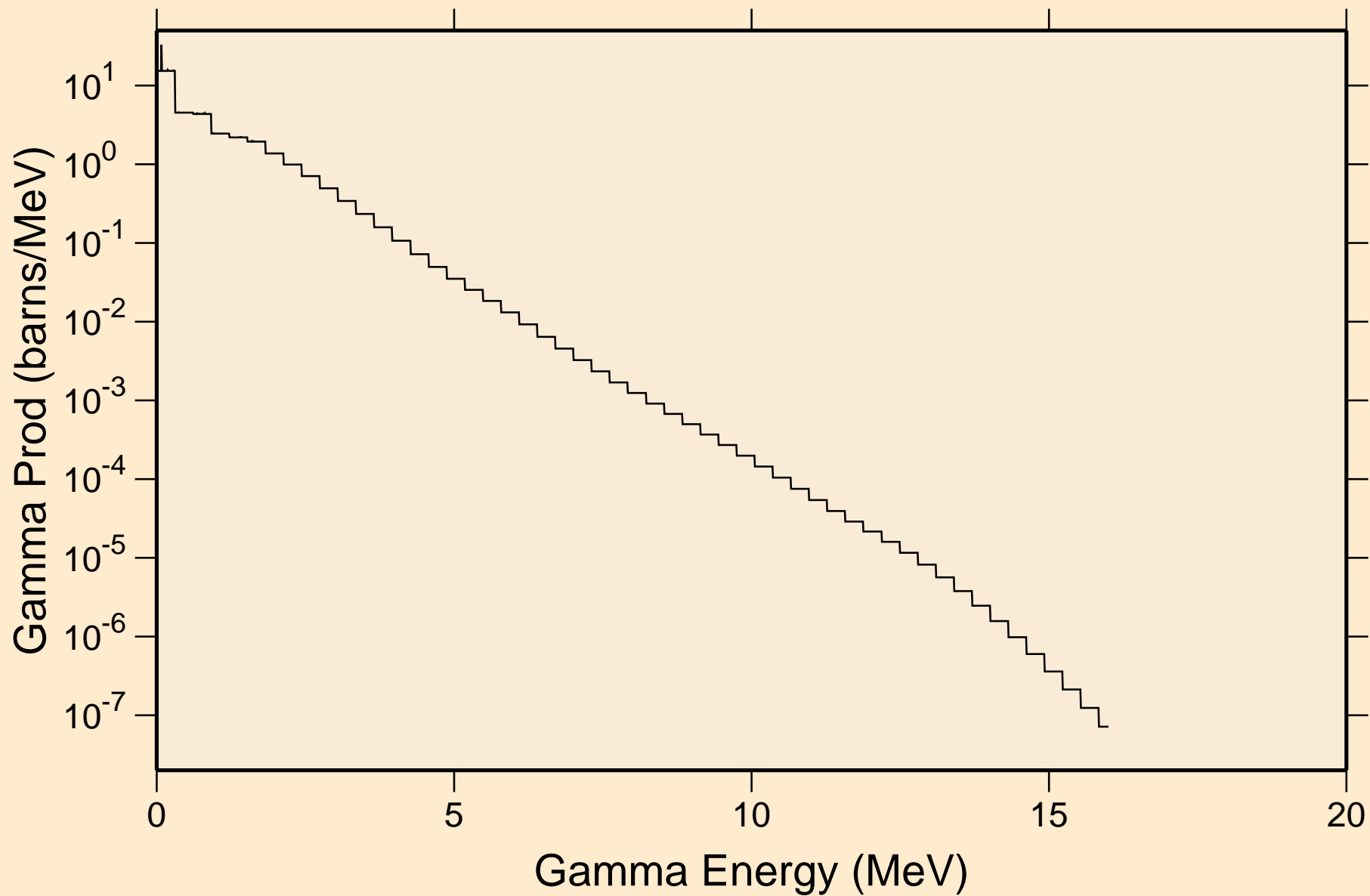

68-ER-166 FOR FENDL-3.1 FROM FENDL-3.1 WITH NJOY2012.50
Particle heating contributions

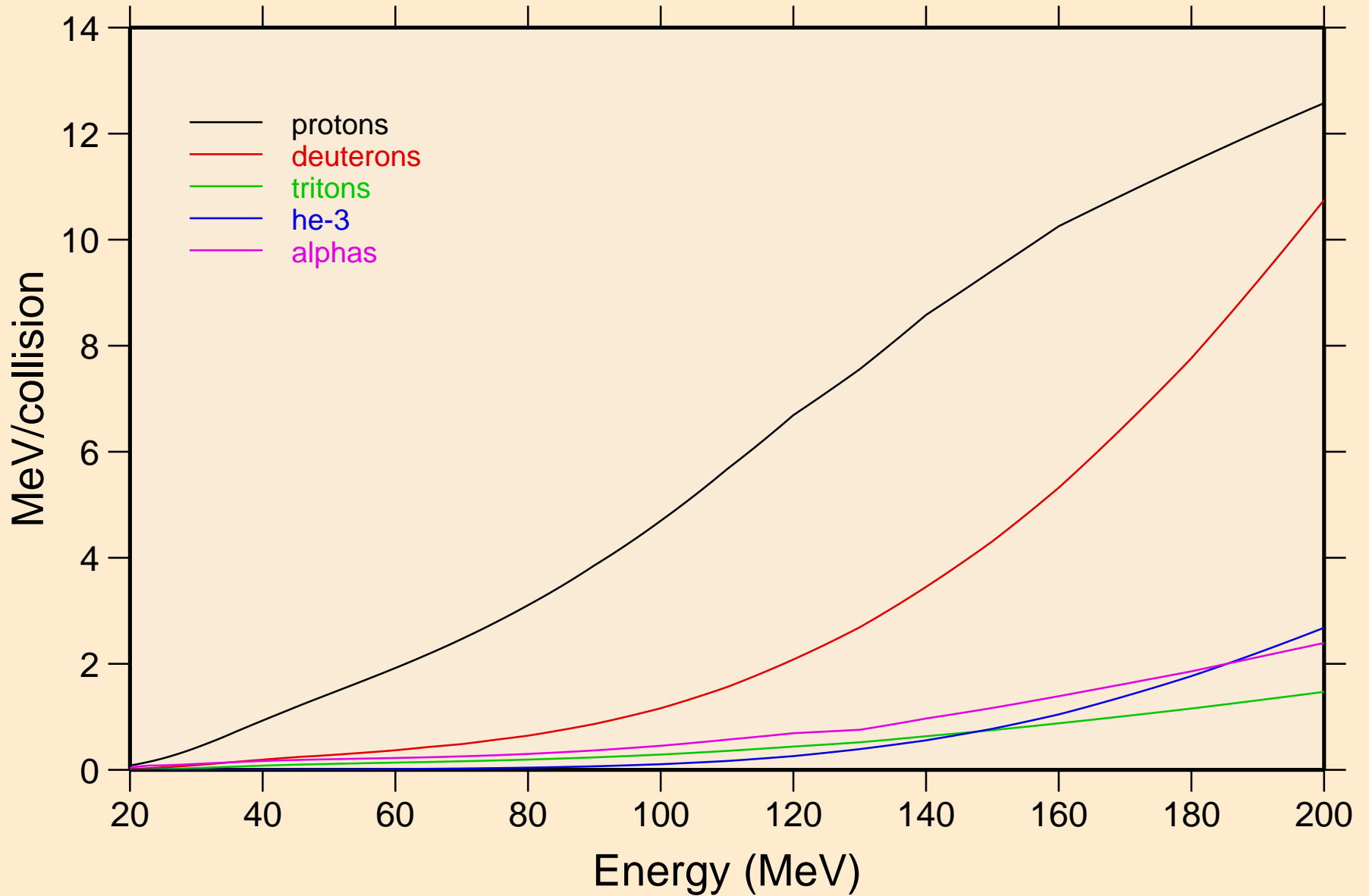

68-ER-166 FOR FENDL-3.1 FROM FENDL-3.1 WITH NJOY2012.50

Recoil Heating

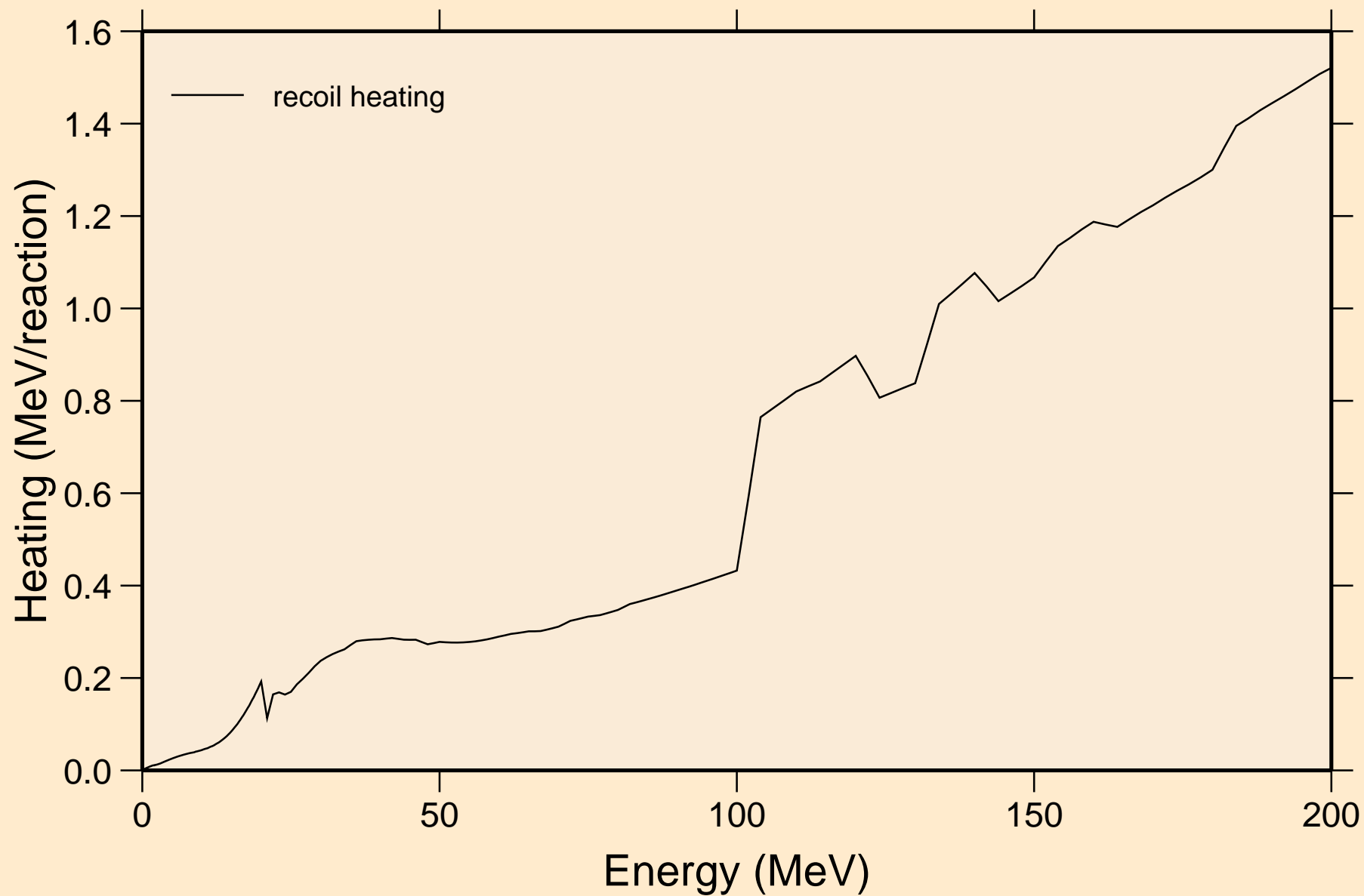

68-ER-166 FOR FENDL-3.1 FROM FENDL-3.1 WITH NJOY2012.50
Particle production cross sections

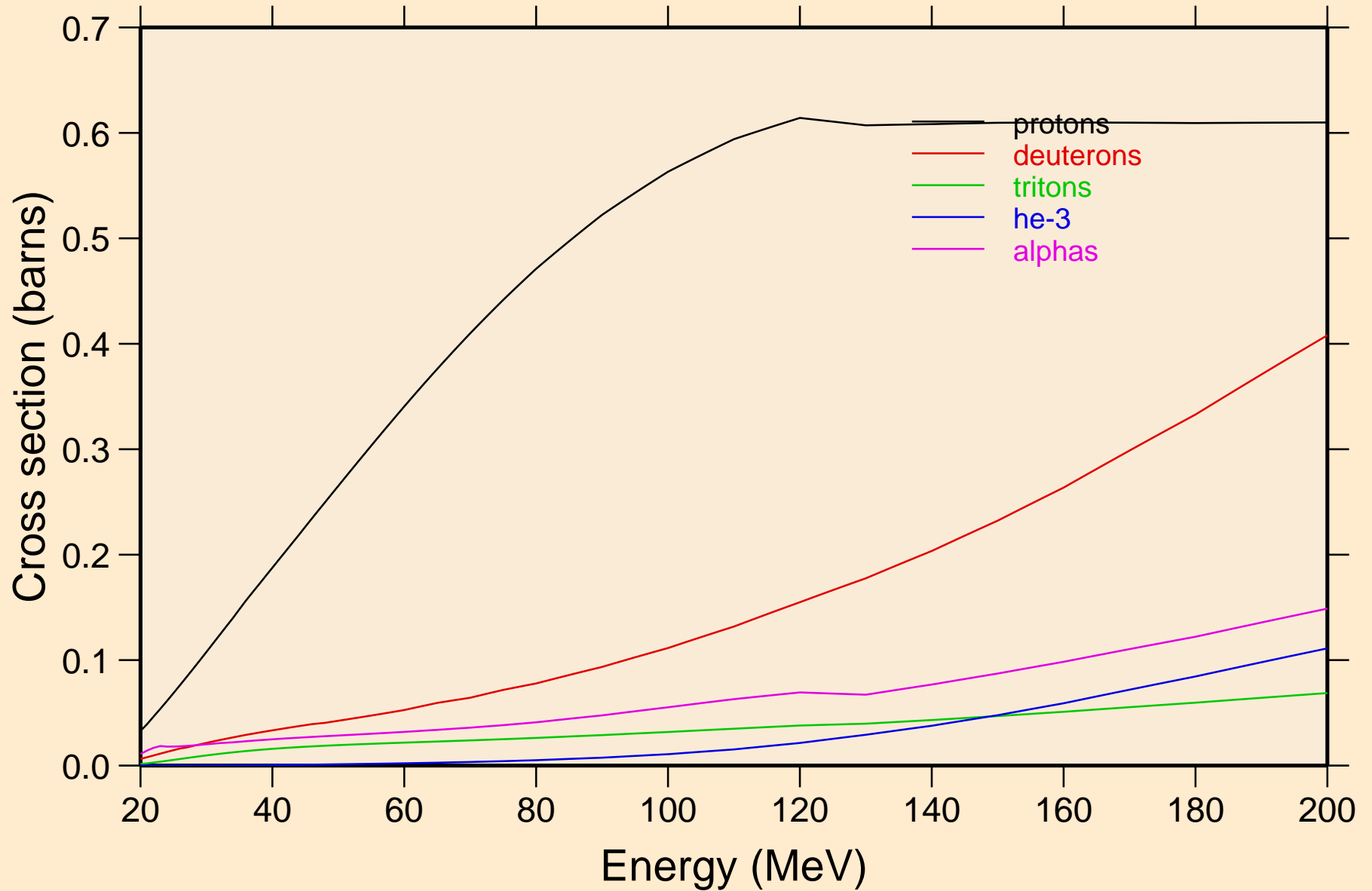

68-ER-166 FOR FENDL-3.1 FROM FENDL-3.1 WITH NJOY2012.50
protons from (n,x)

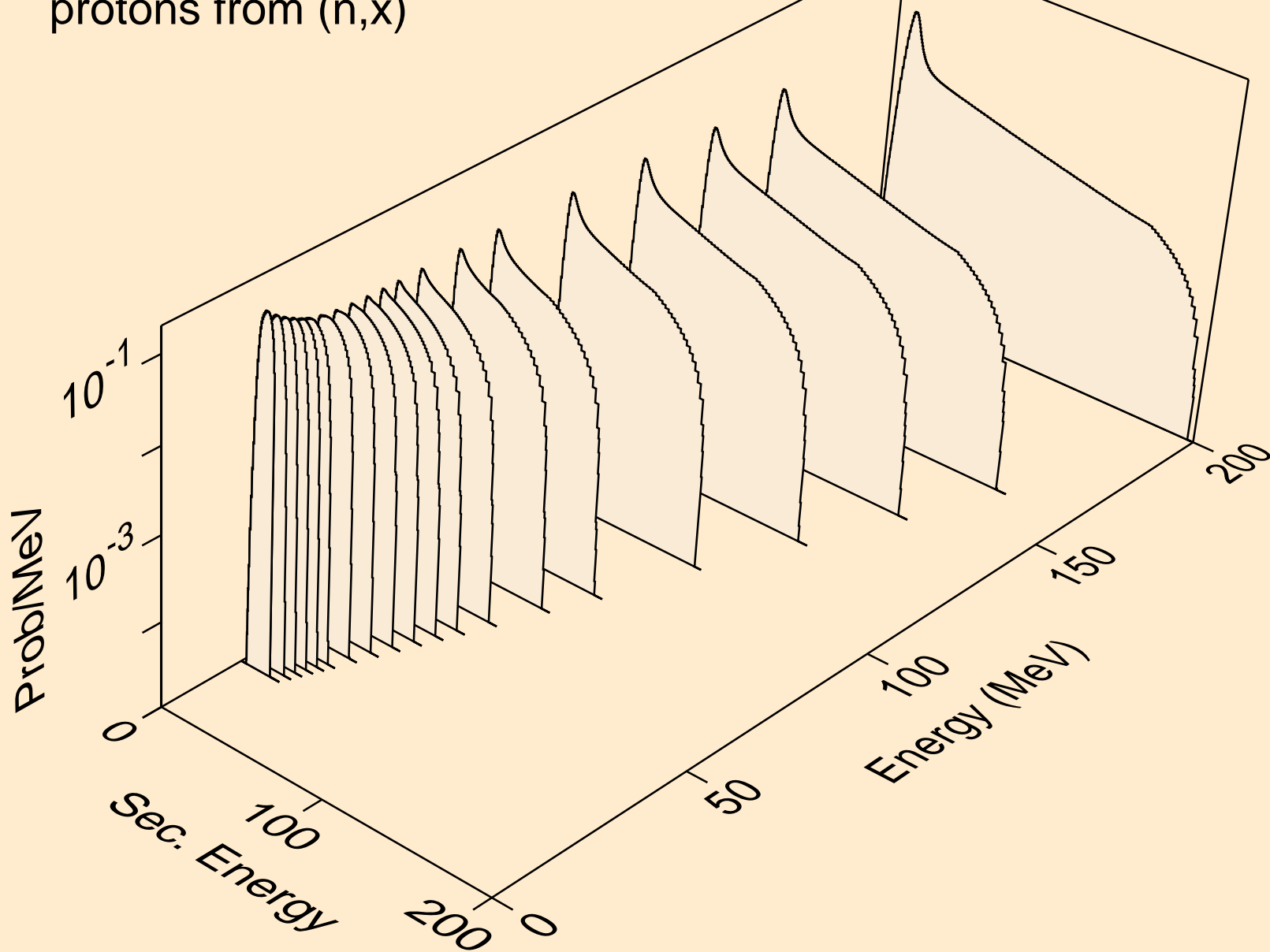

68-ER-166 FOR FENDL-3.1 FROM FENDL-3.1 WITH NJOY2012.50
deuterons from (n,x)

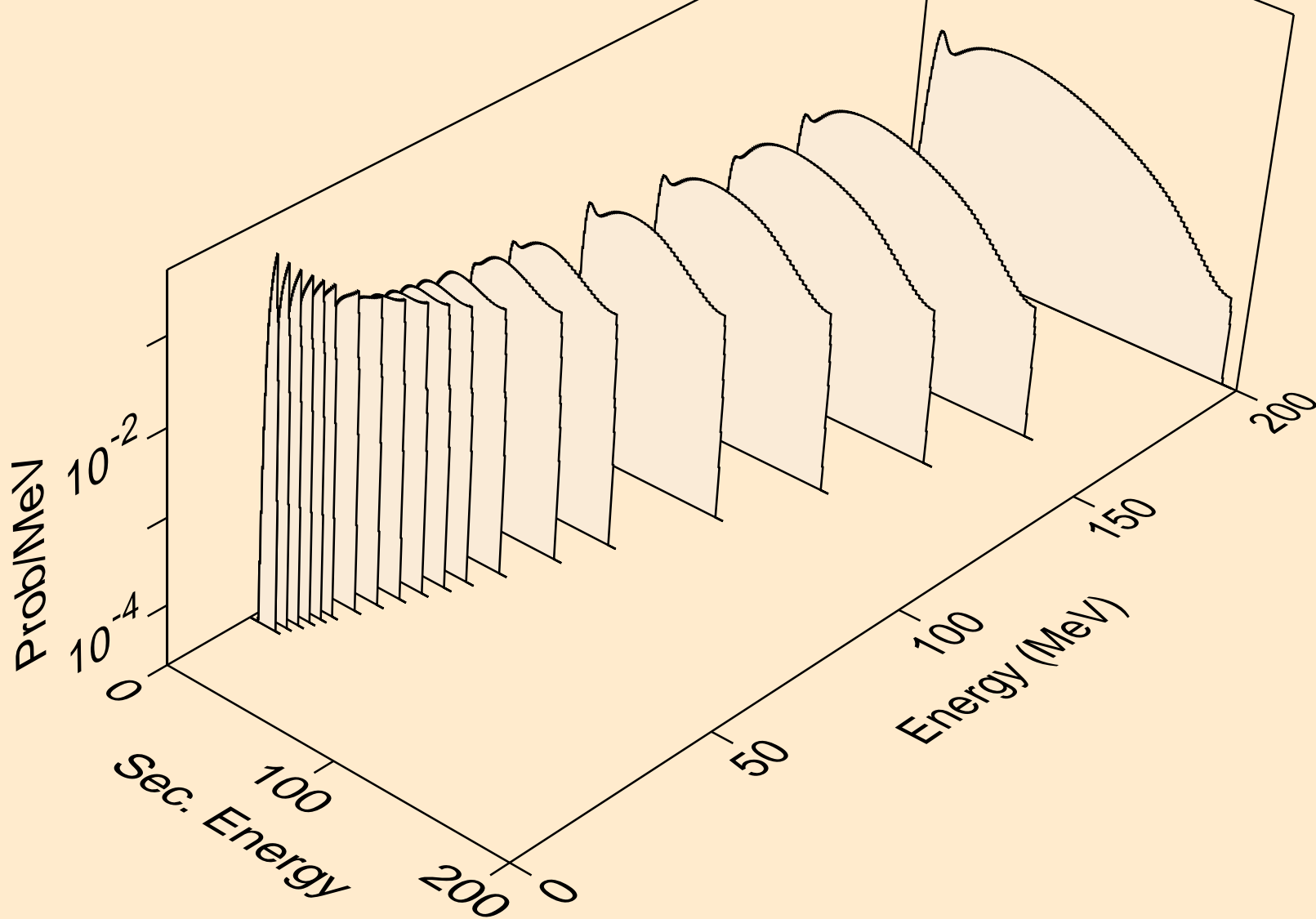

68-ER-166 FOR FENDL-3.1 FROM FENDL-3.1 WITH NJOY2012.50
tritons from (n,x)

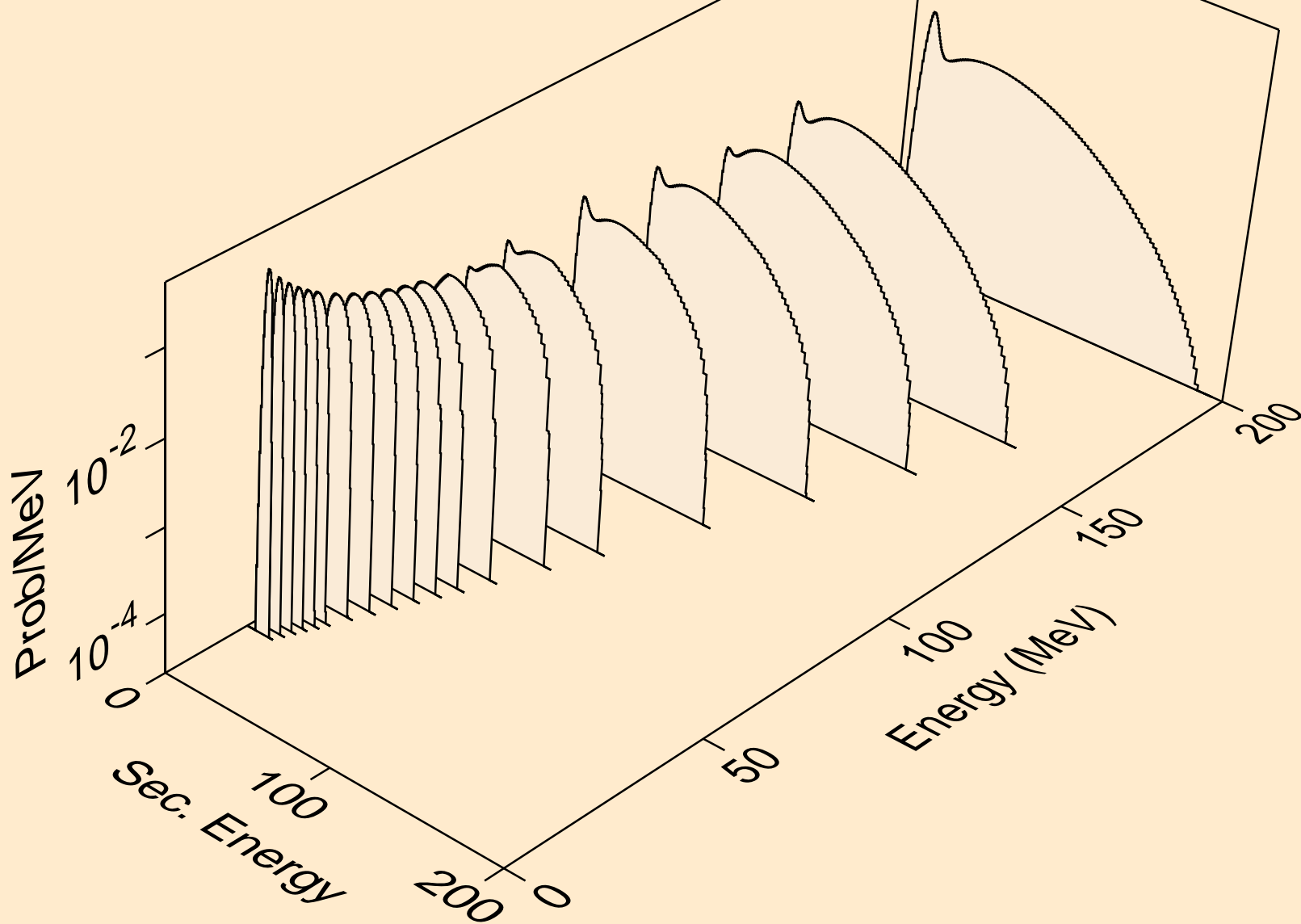

68-ER-166 FOR FENDL-3.1 FROM FENDL-3.1 WITH NJOY2012.50
he3s from (n,x)

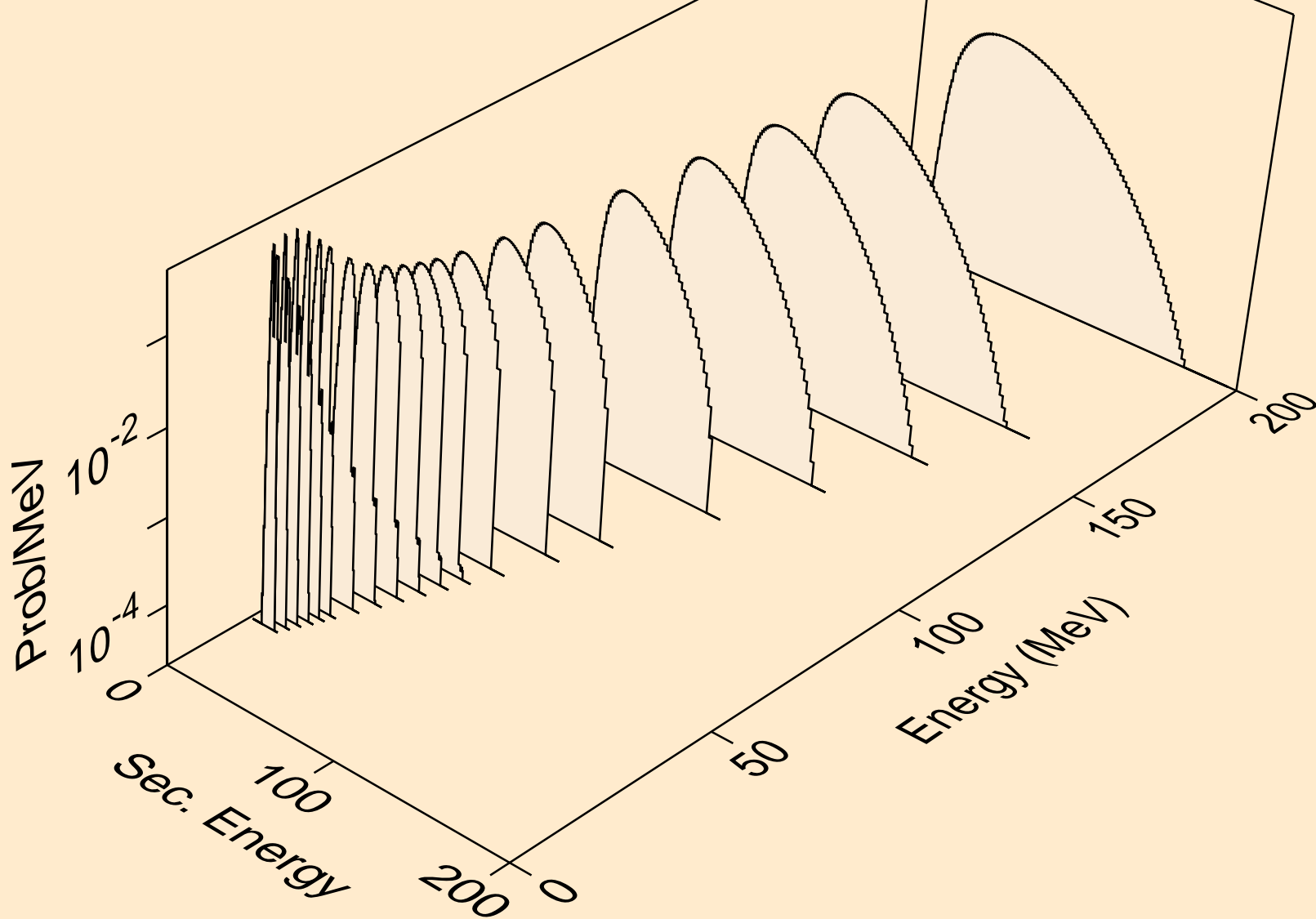

68-ER-166 FOR FENDL-3.1 FROM FENDL-3.1 WITH NJOY2012.50
alphas from (n,x)

