

74-W-182 FOR FENDL-3.1 FROM INDL/V-3 WITH NJOY2012.50+ C
Principal cross sections

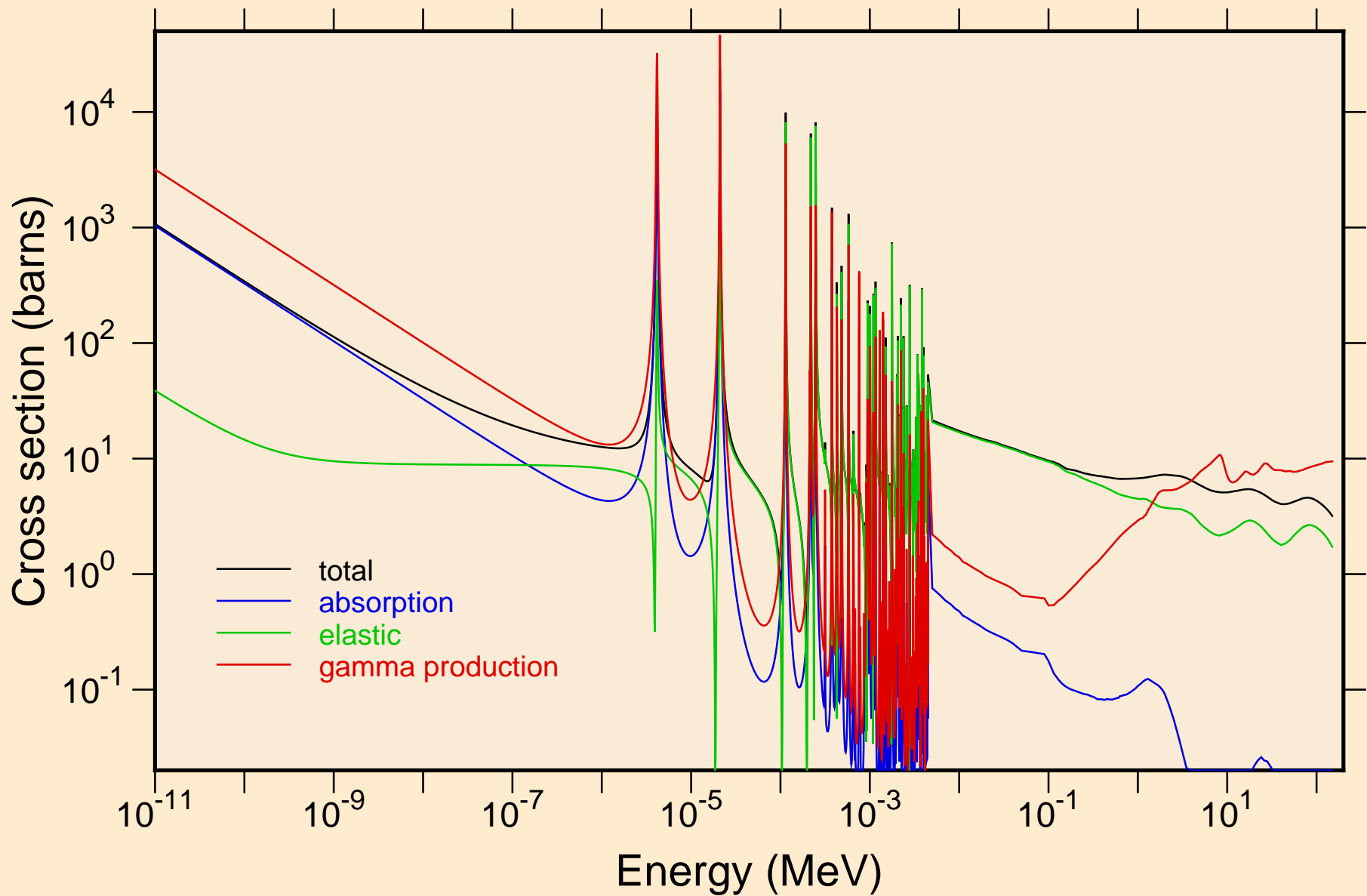

74-W-182 FOR FENDL-3.1 FROM INDL/V-3 WITH NJOY2012.50+ C
resonance total cross section

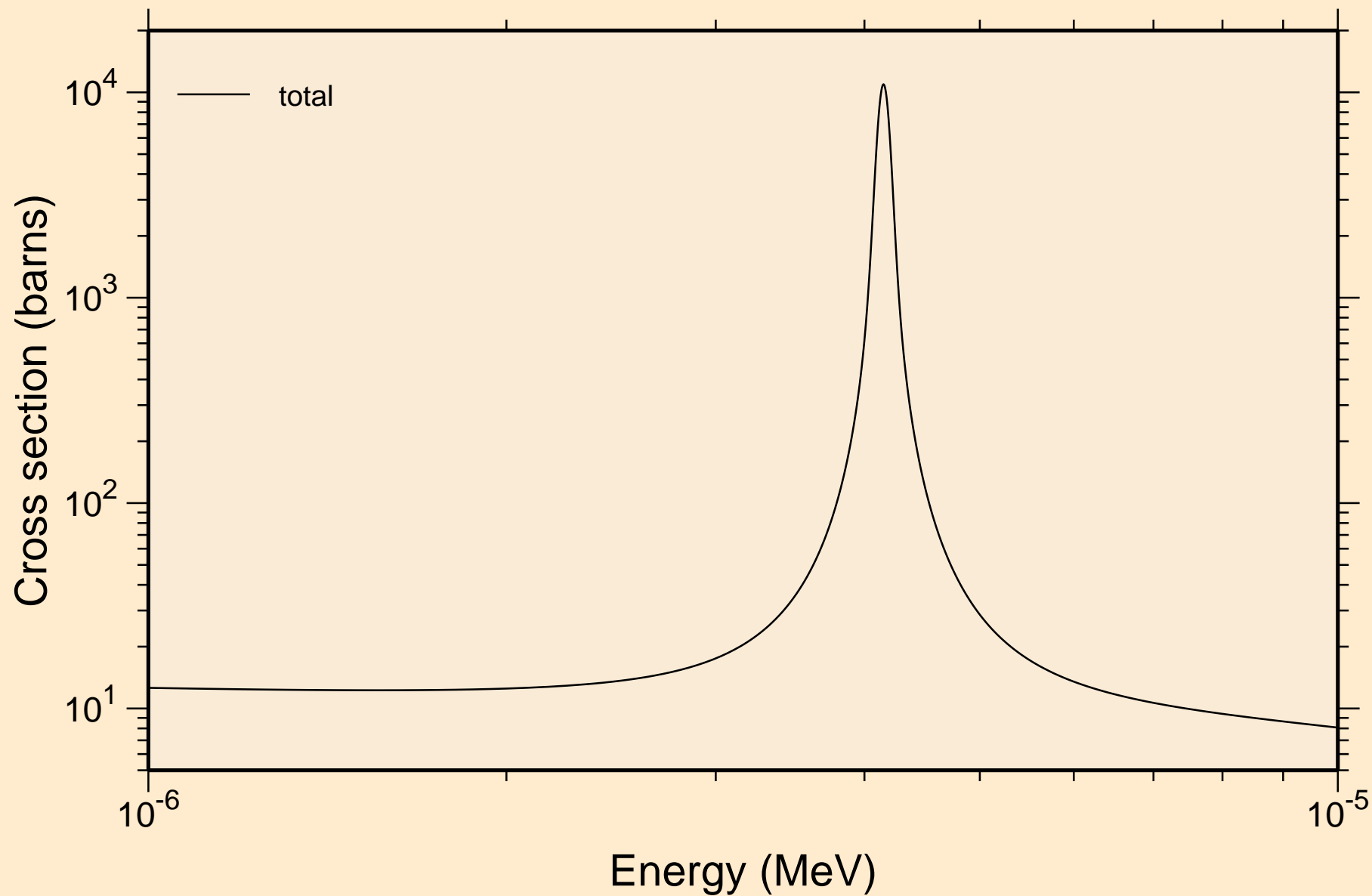

74-W-182 FOR FENDL-3.1 FROM INDL/V-3 WITH NJOY2012.50+ C
resonance total cross section

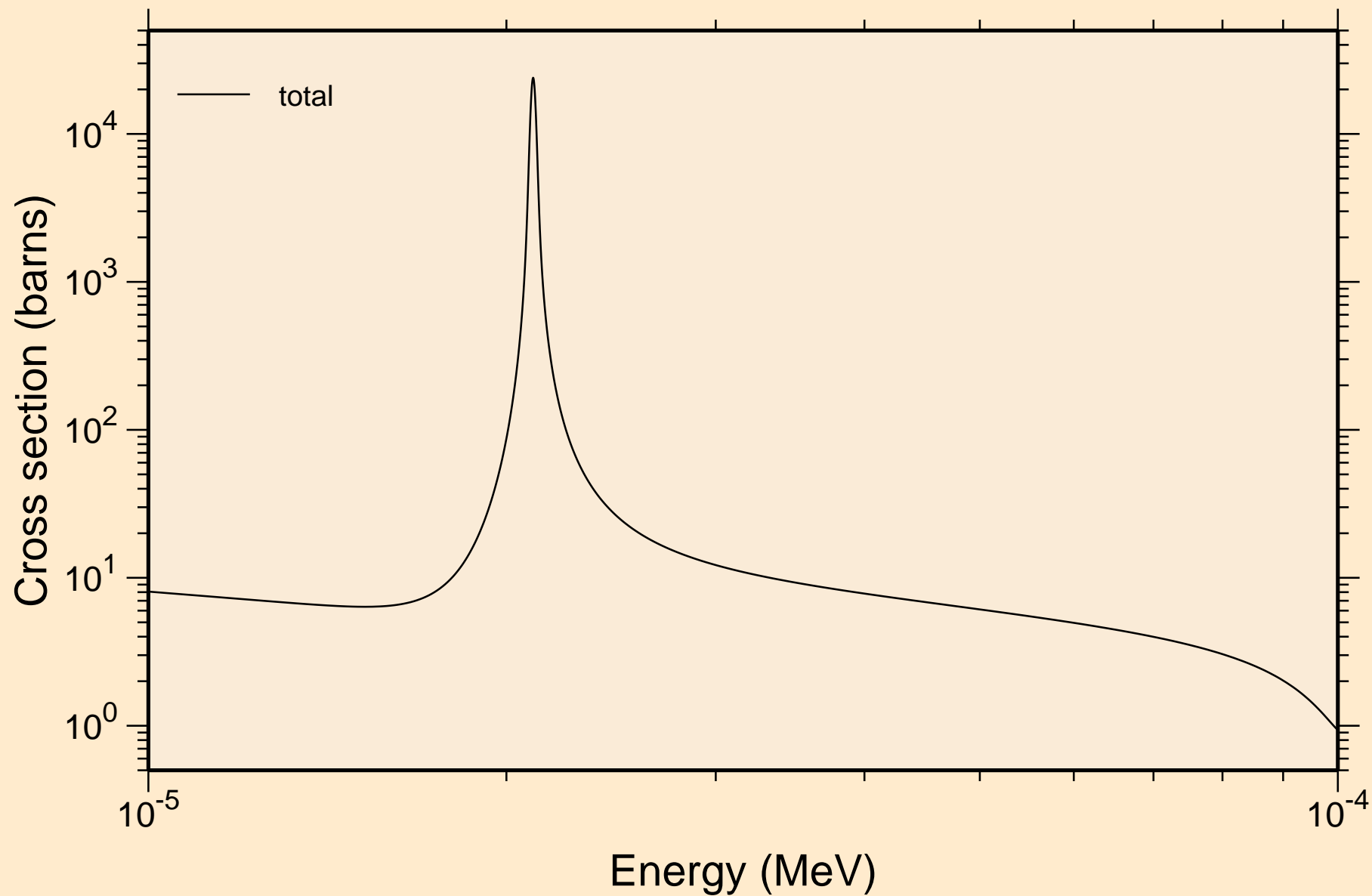

74-W-182 FOR FENDL-3.1 FROM INDL/V-3 WITH NJOY2012.50+ C
resonance total cross section

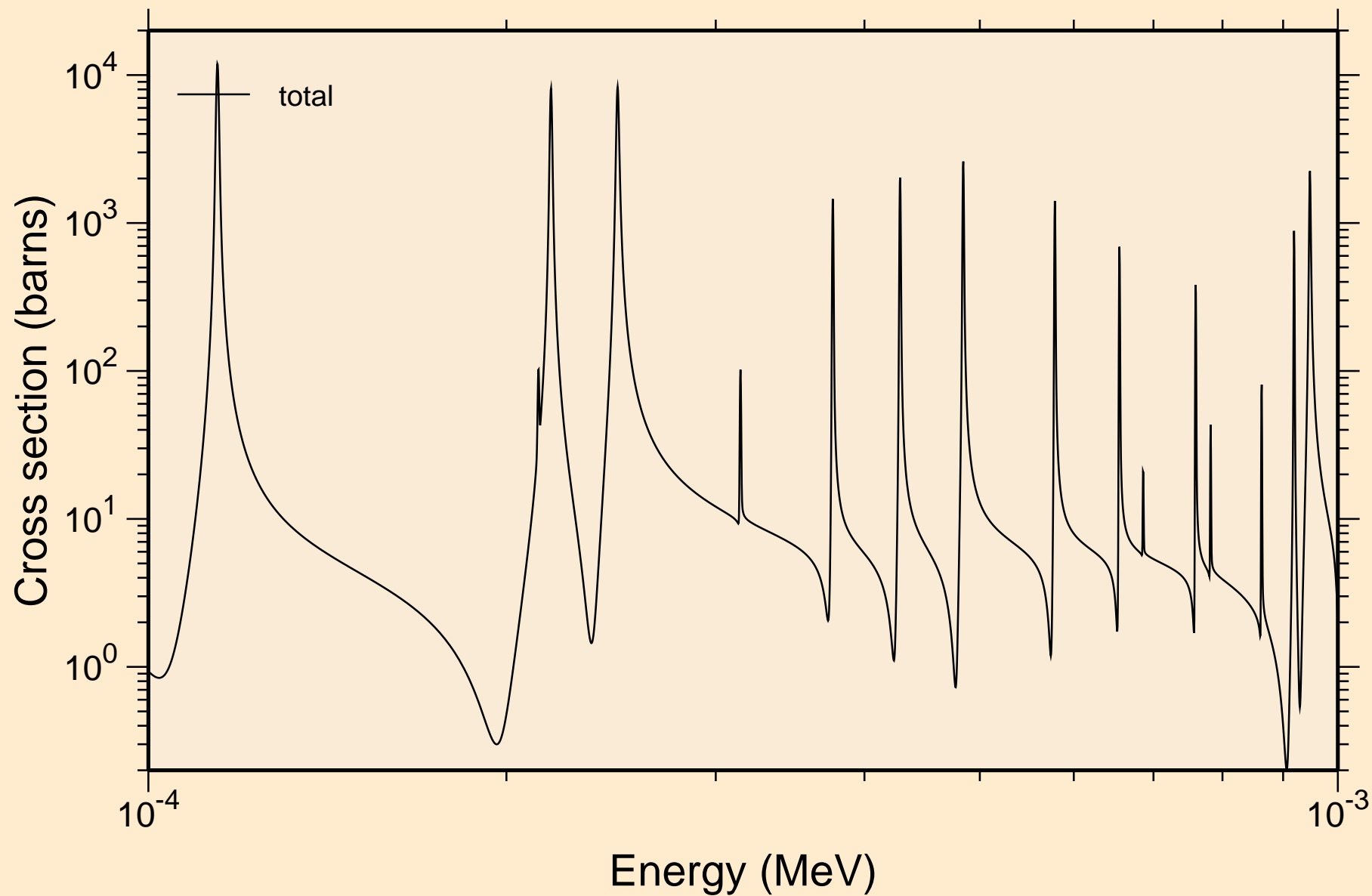

74-W-182 FOR FENDL-3.1 FROM INDL/V-3 WITH NJOY2012.50+ C
resonance total cross section

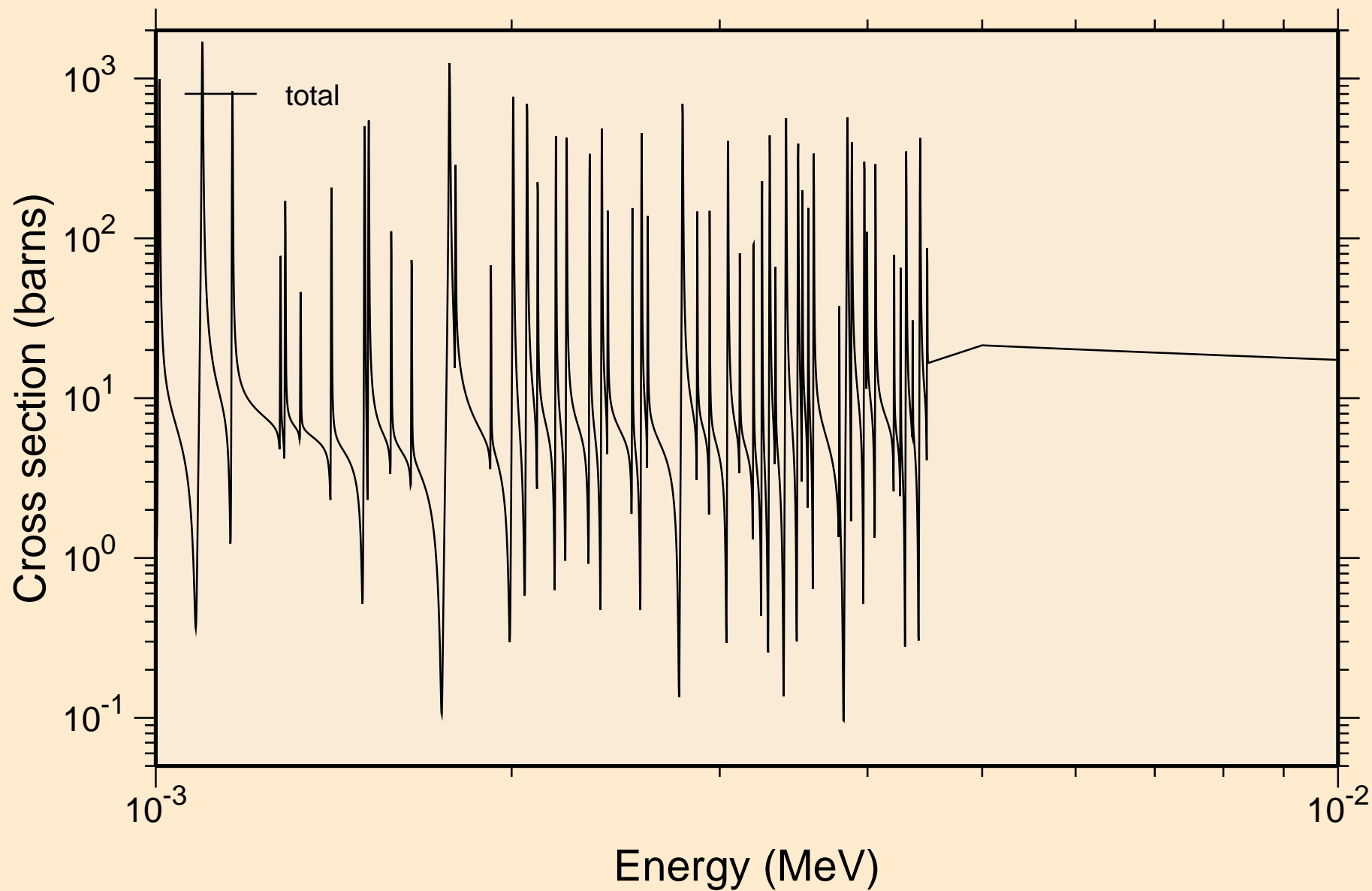

74-W-182 FOR FENDL-3.1 FROM INDL/V-3 WITH NJOY2012.50+ C
resonance absorption cross sections

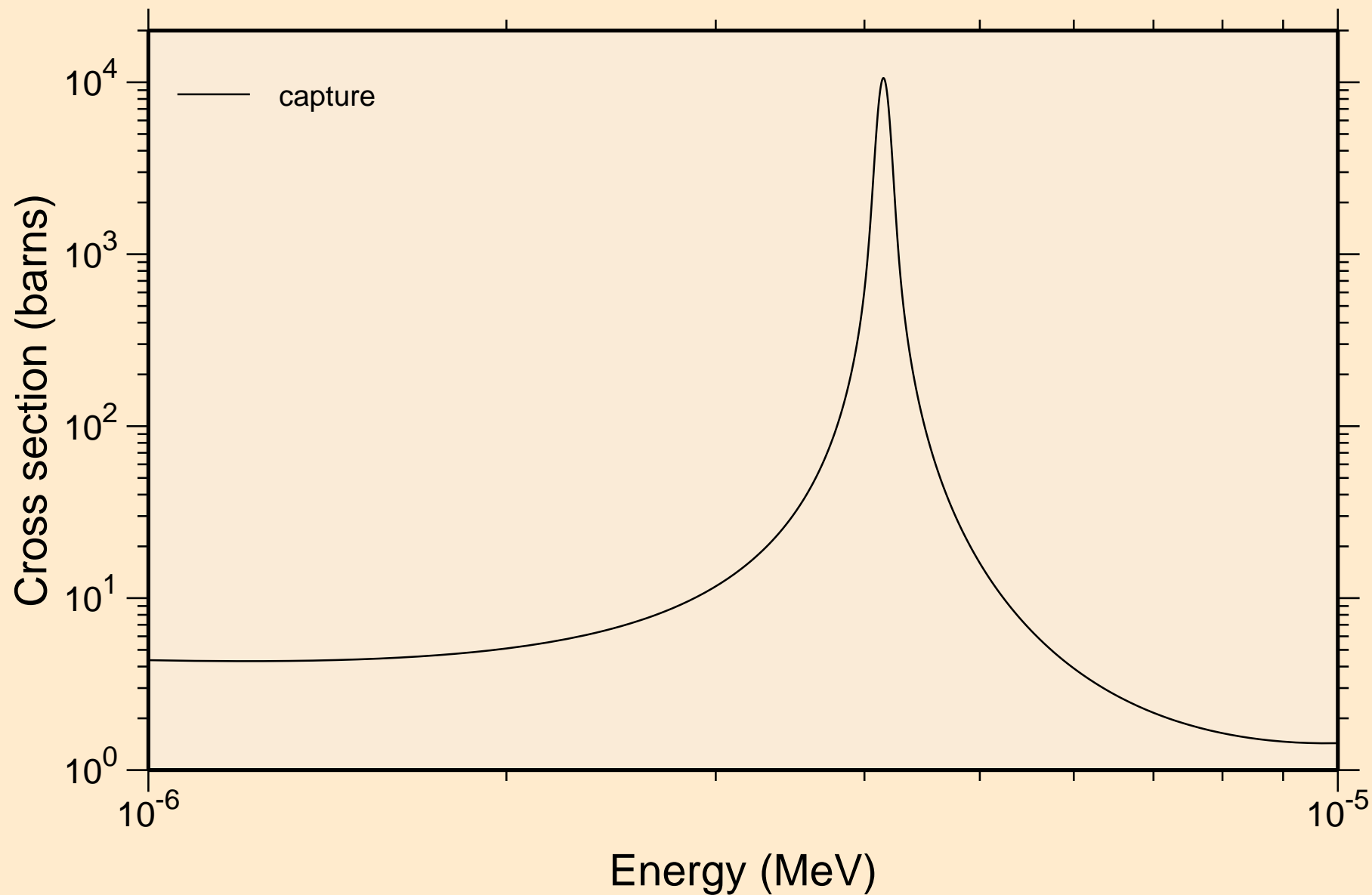

74-W-182 FOR FENDL-3.1 FROM INDL/V-3 WITH NJOY2012.50+ C
resonance absorption cross sections

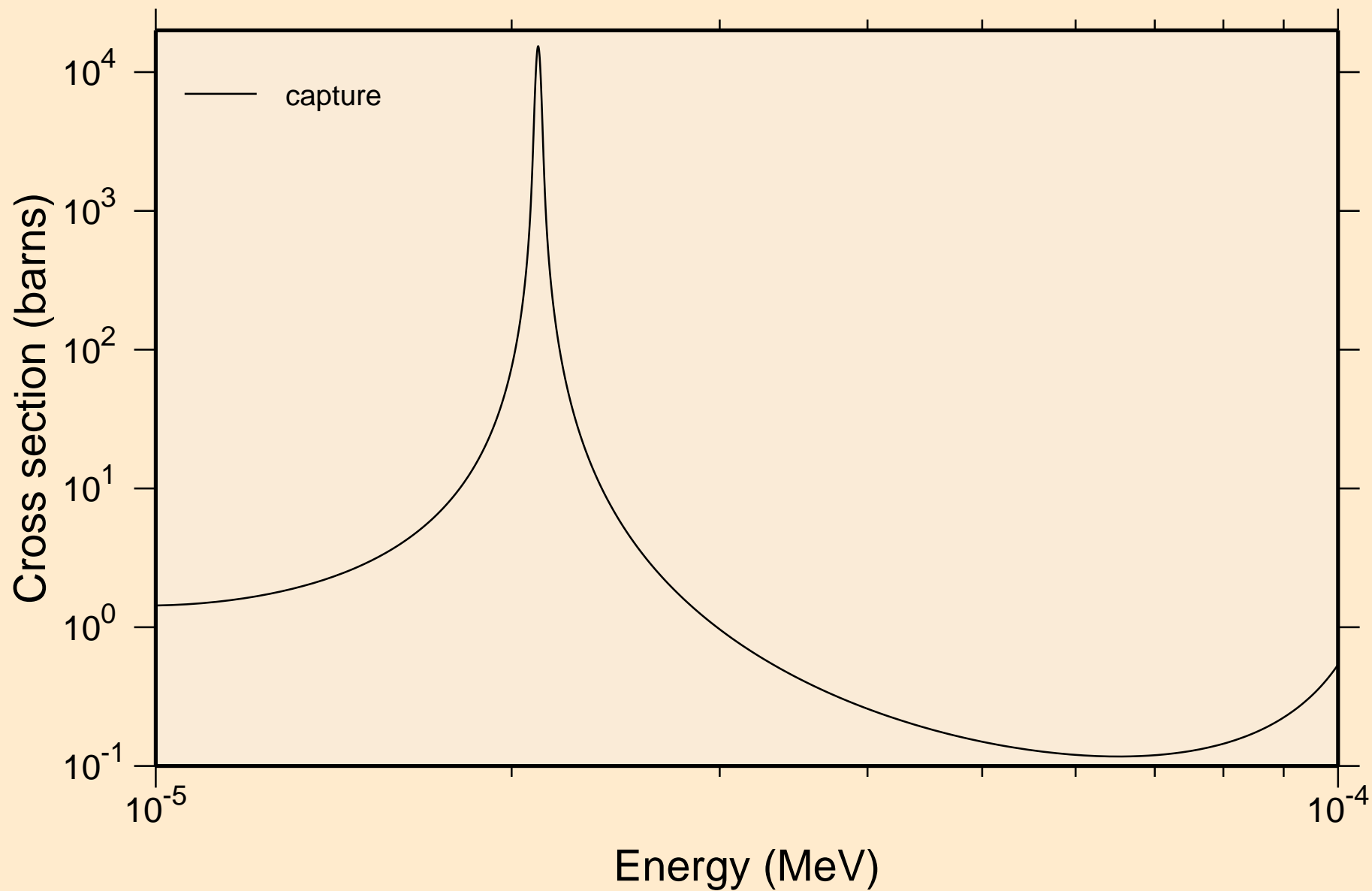

74-W-182 FOR FENDL-3.1 FROM INDL/V-3 WITH NJOY2012.50+ C
resonance absorption cross sections

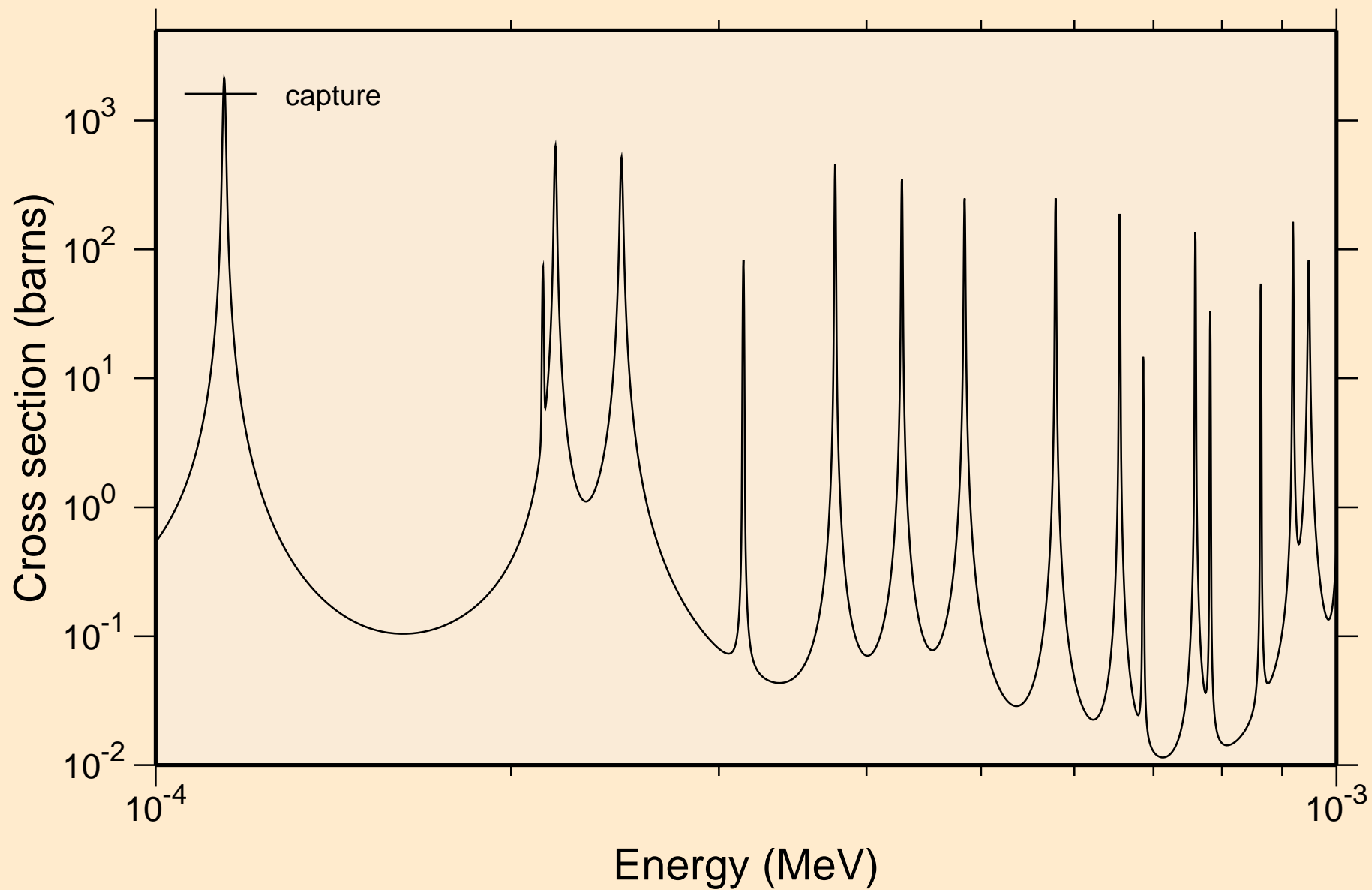

74-W-182 FOR FENDL-3.1 FROM INDL/V-3 WITH NJOY2012.50+ C
resonance absorption cross sections

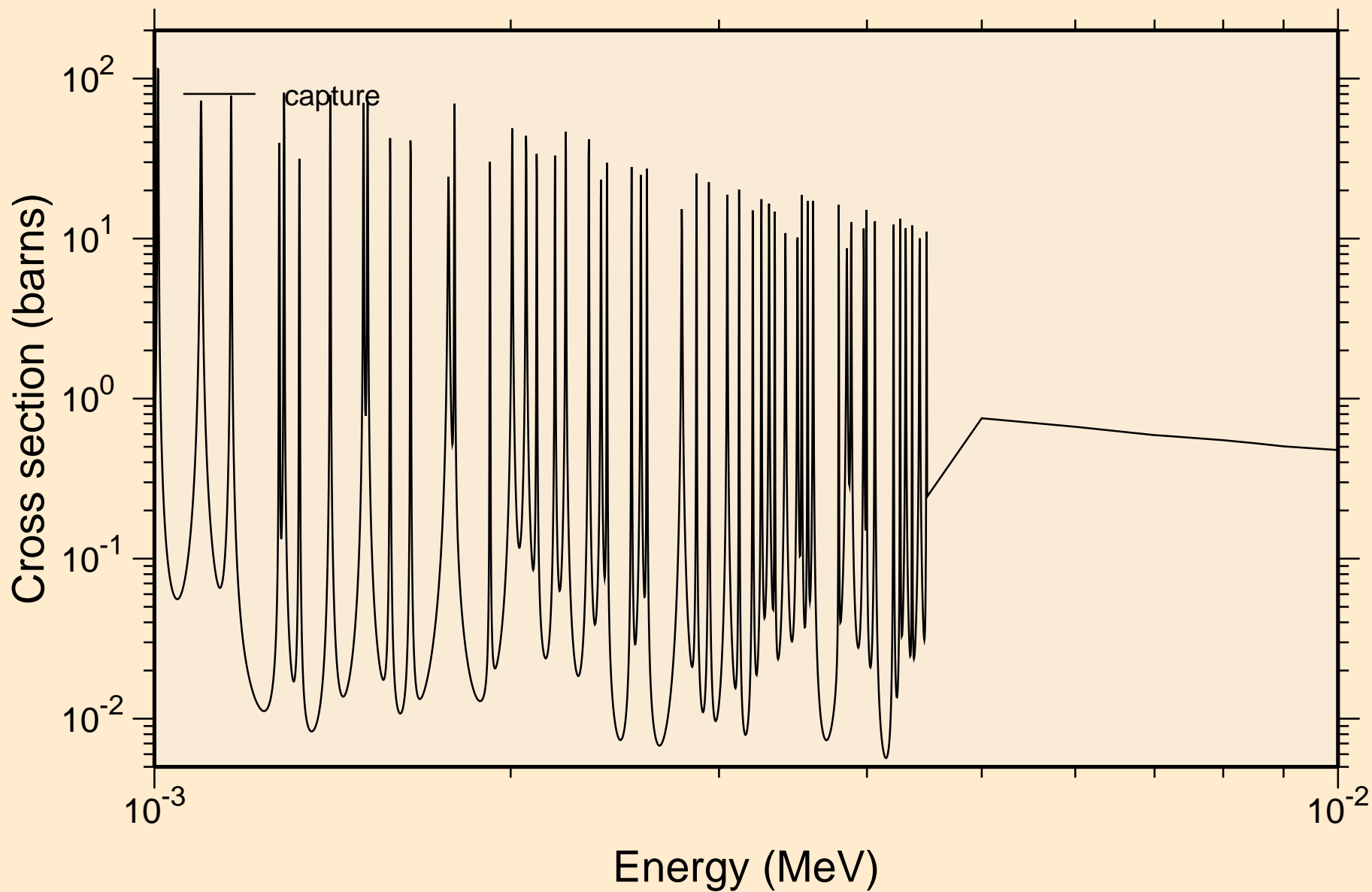

74-W-182 FOR FENDL-3.1 FROM INDL/V-3 WITH NJOY2012.50+ C
UR total cross section

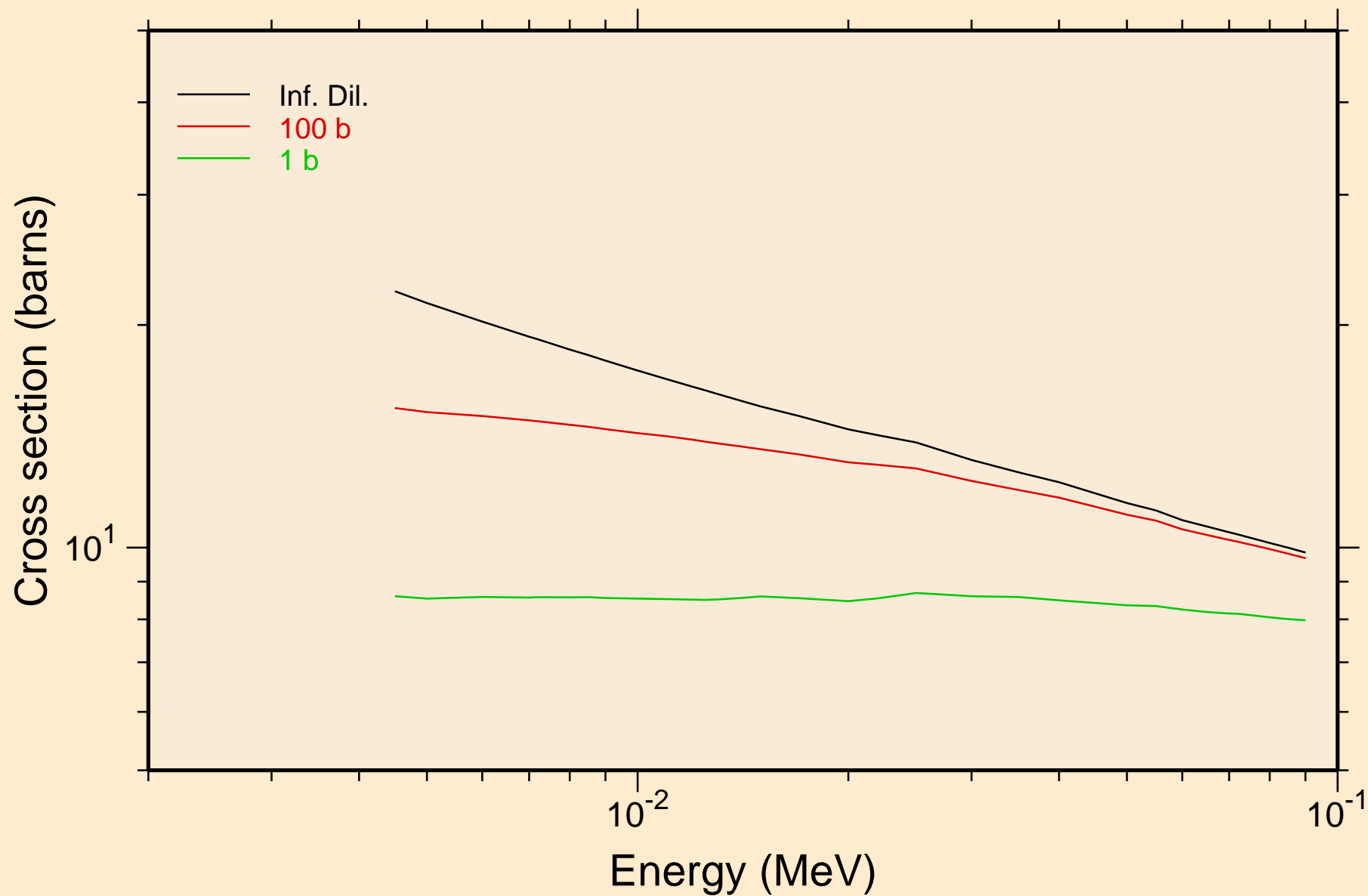

74-W-182 FOR FENDL-3.1 FROM INDL/V-3 WITH NJOY2012.50+ C
UR elastic cross section

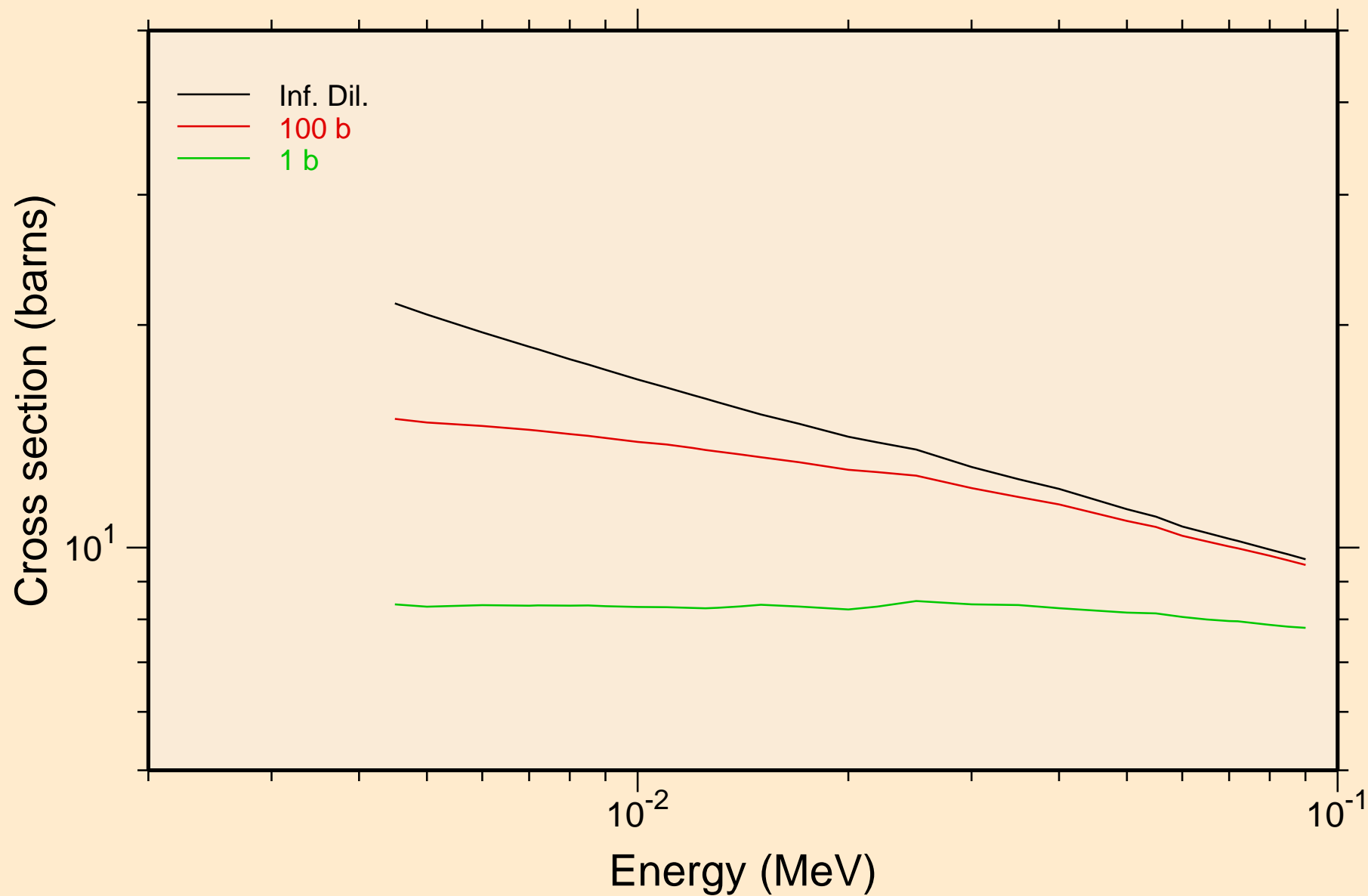

74-W-182 FOR FENDL-3.1 FROM INDL/V-3 WITH NJOY2012.50+ C
UR capture cross section

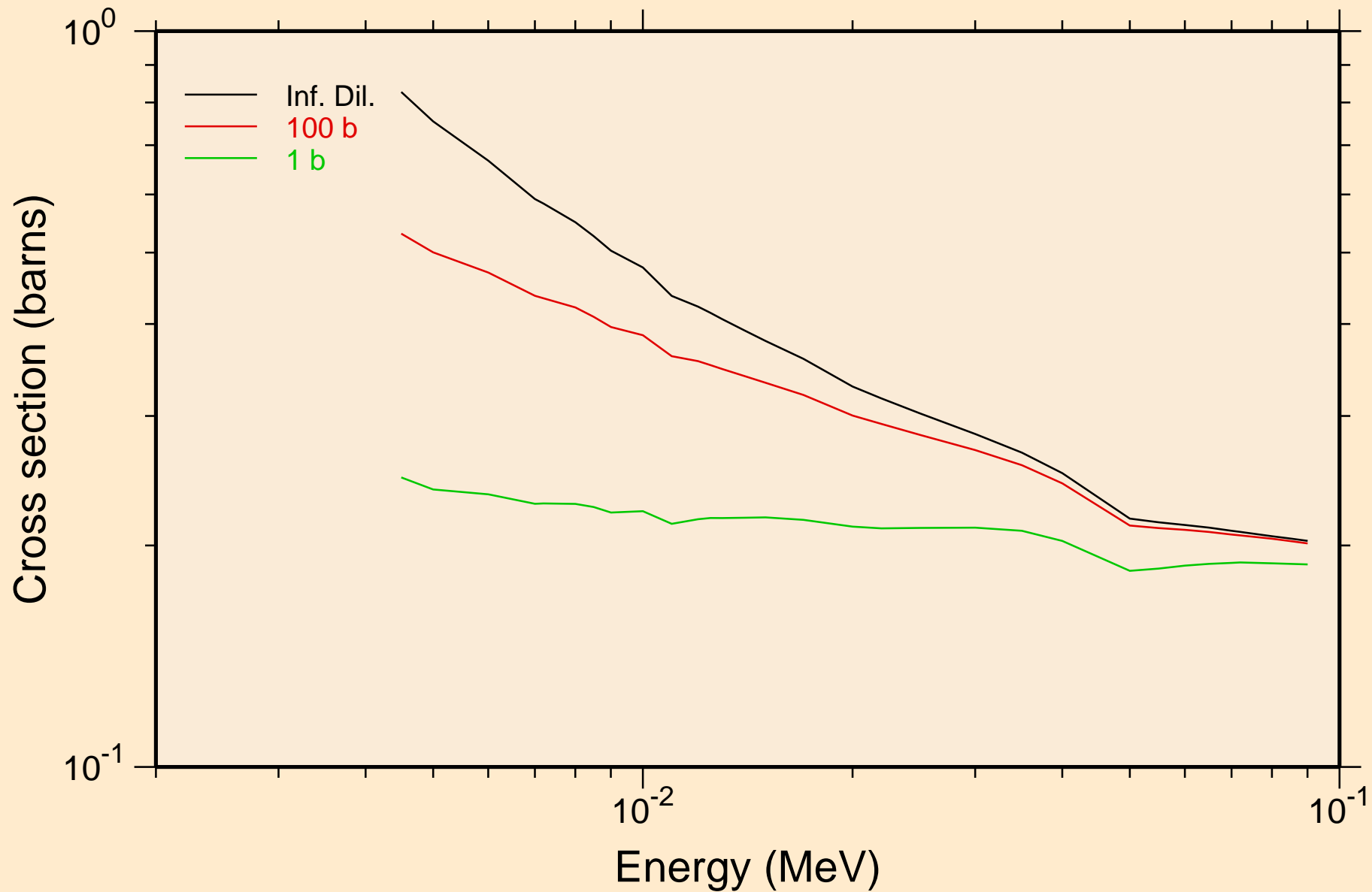

74-W-182 FOR FENDL-3.1 FROM INDL/V-3 WITH NJOY2012.50+ C Heating

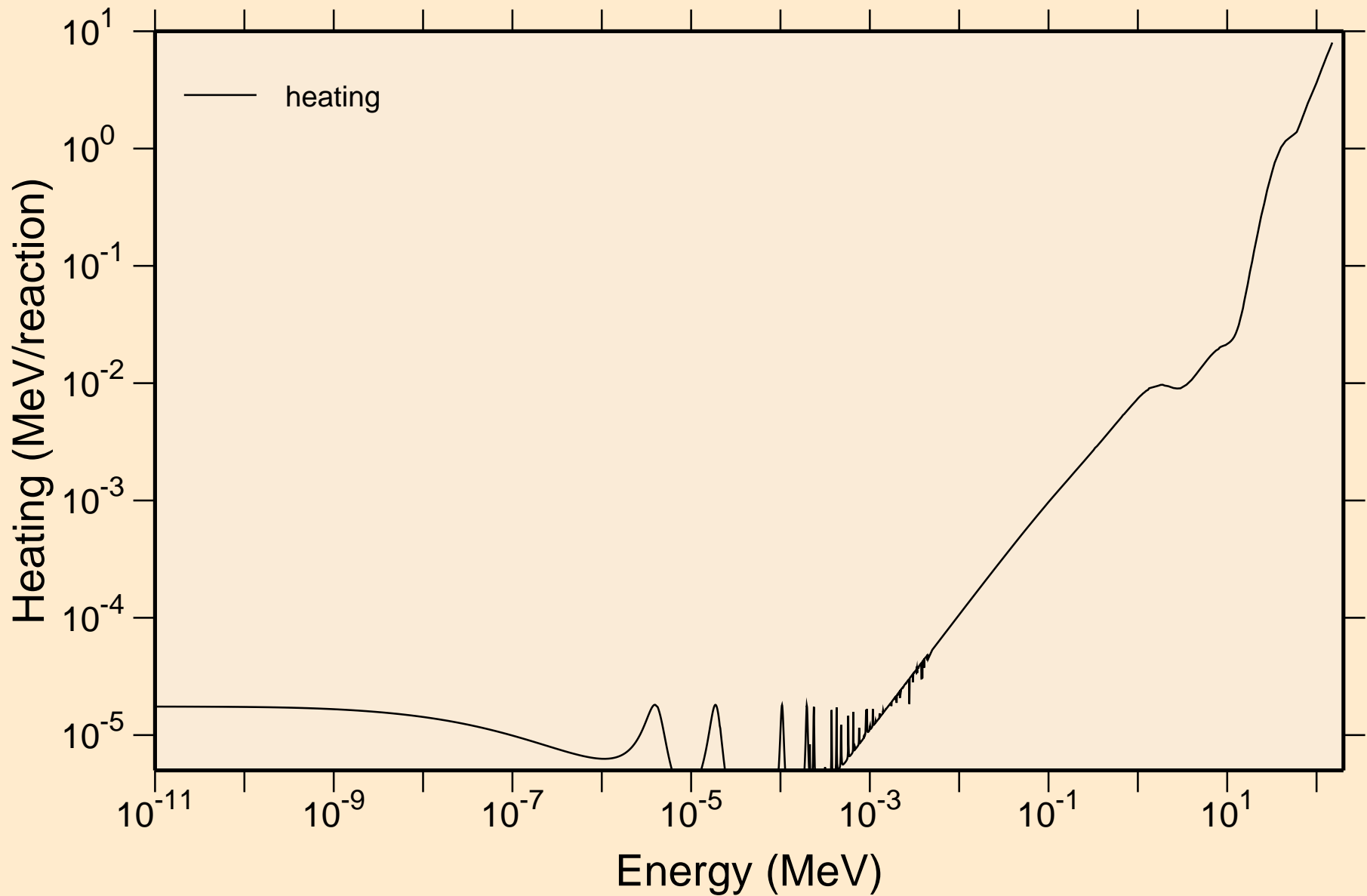

74-W-182 FOR FENDL-3.1 FROM INDL/V-3 WITH NJOY2012.50+ C Damage

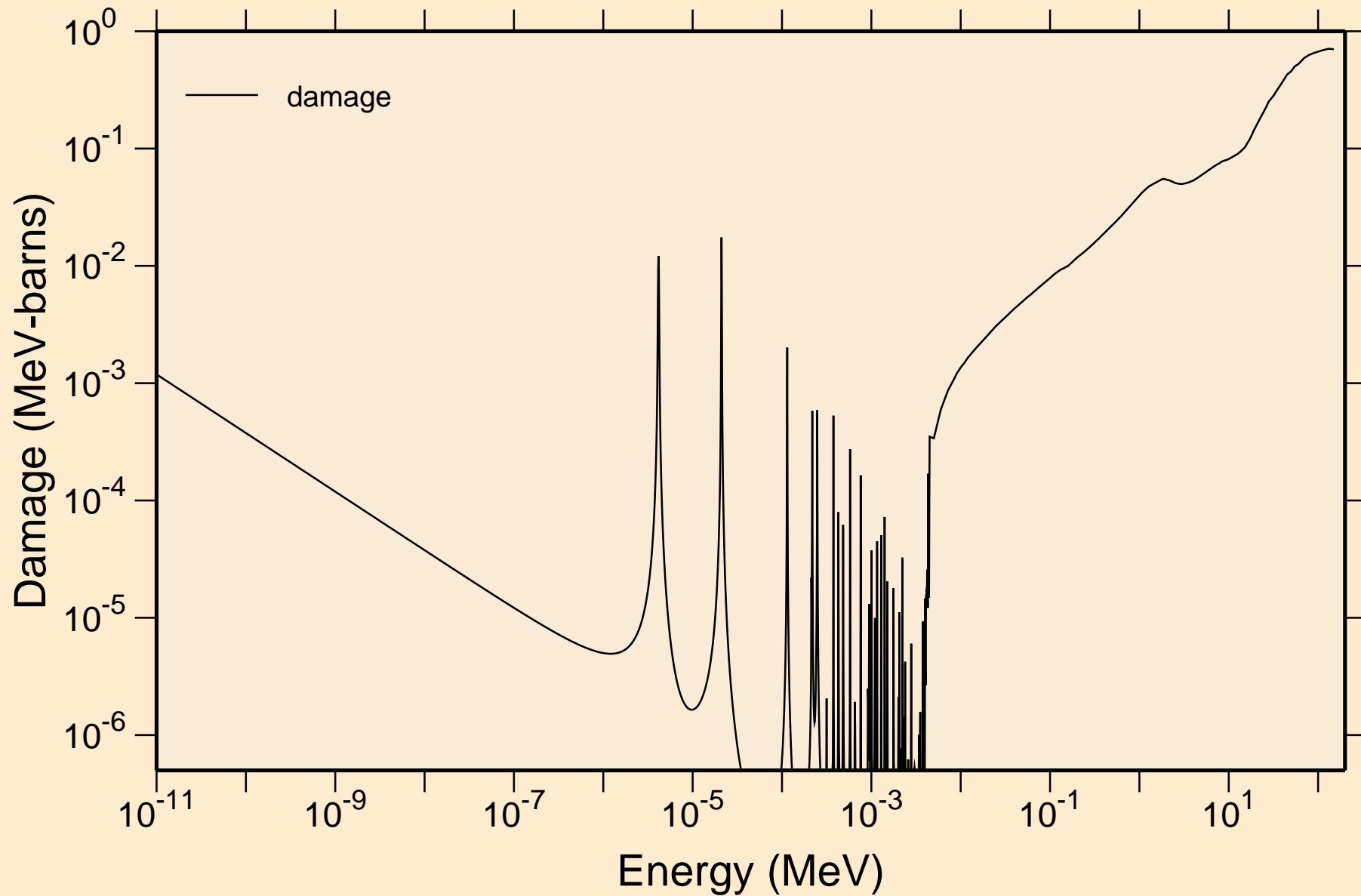

74-W-182 FOR FENDL-3.1 FROM INDL/V-3 WITH NJOY2012.50+ C
Non-threshold reactions

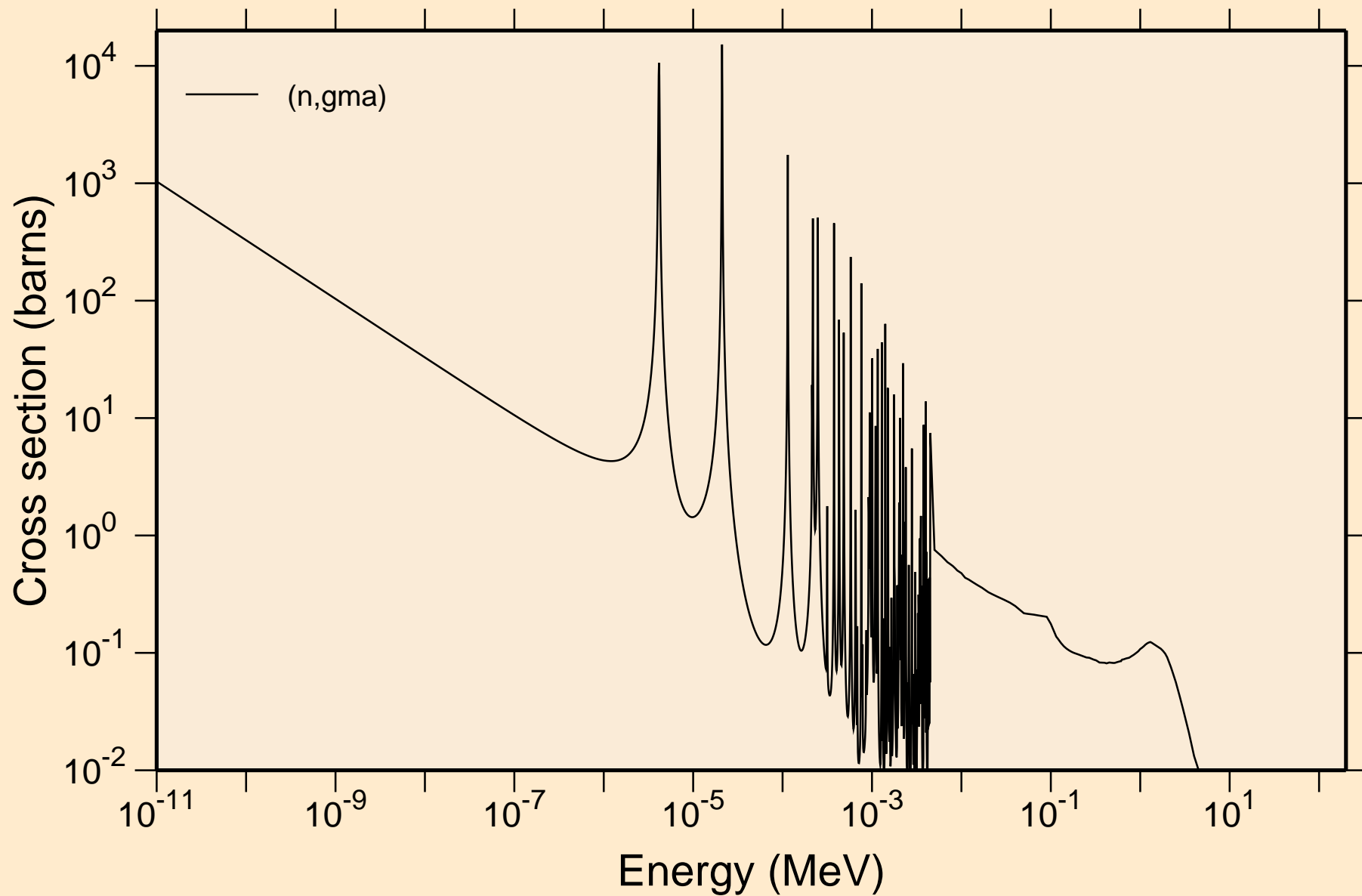

74-W-182 FOR FENDL-3.1 FROM INDL/V-3 WITH NJOY2012.50+ C

Principal cross sections

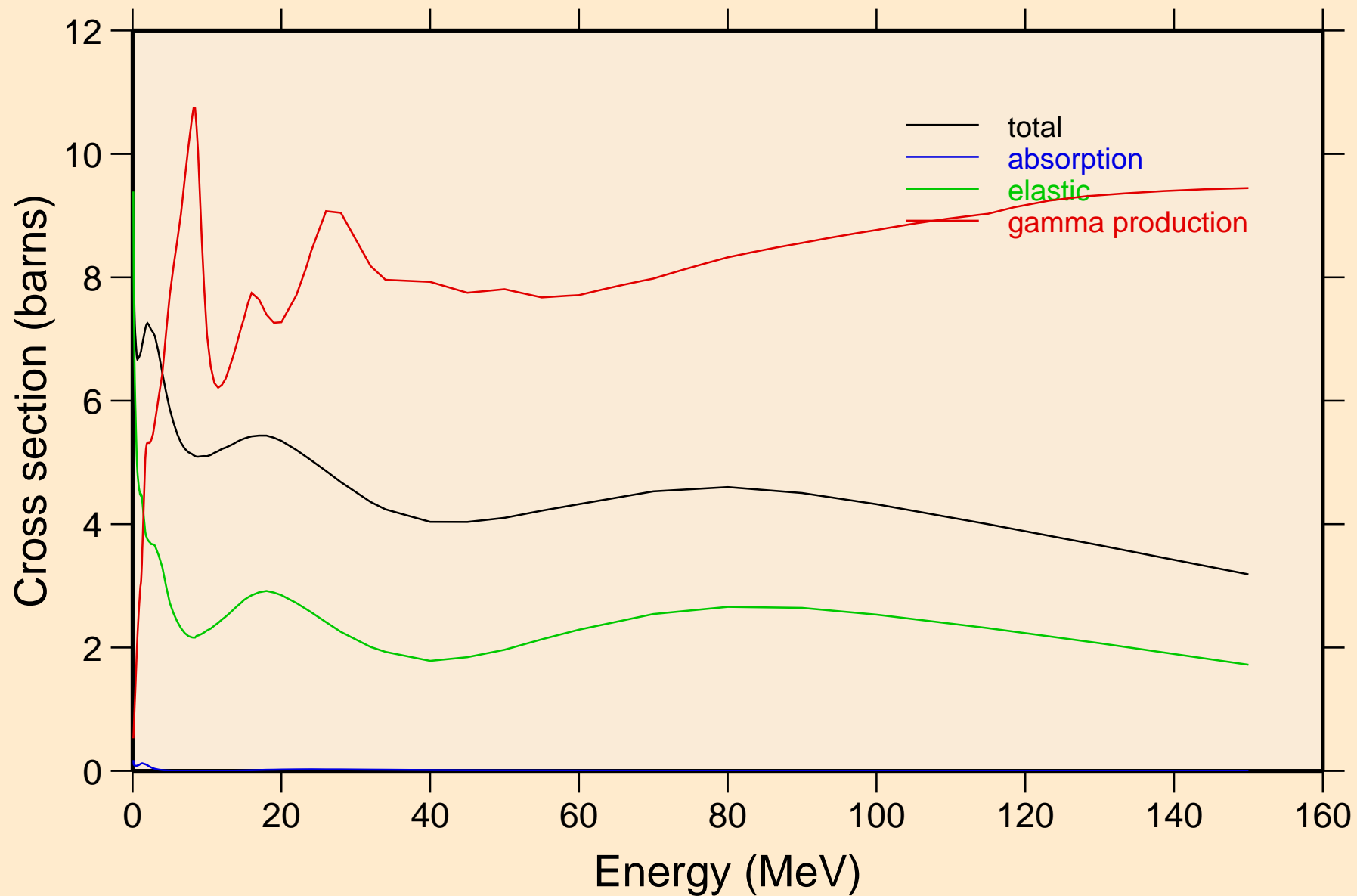

74-W-182 FOR FENDL-3.1 FROM INDL/V-3 WITH NJOY2012.50+ C Heating

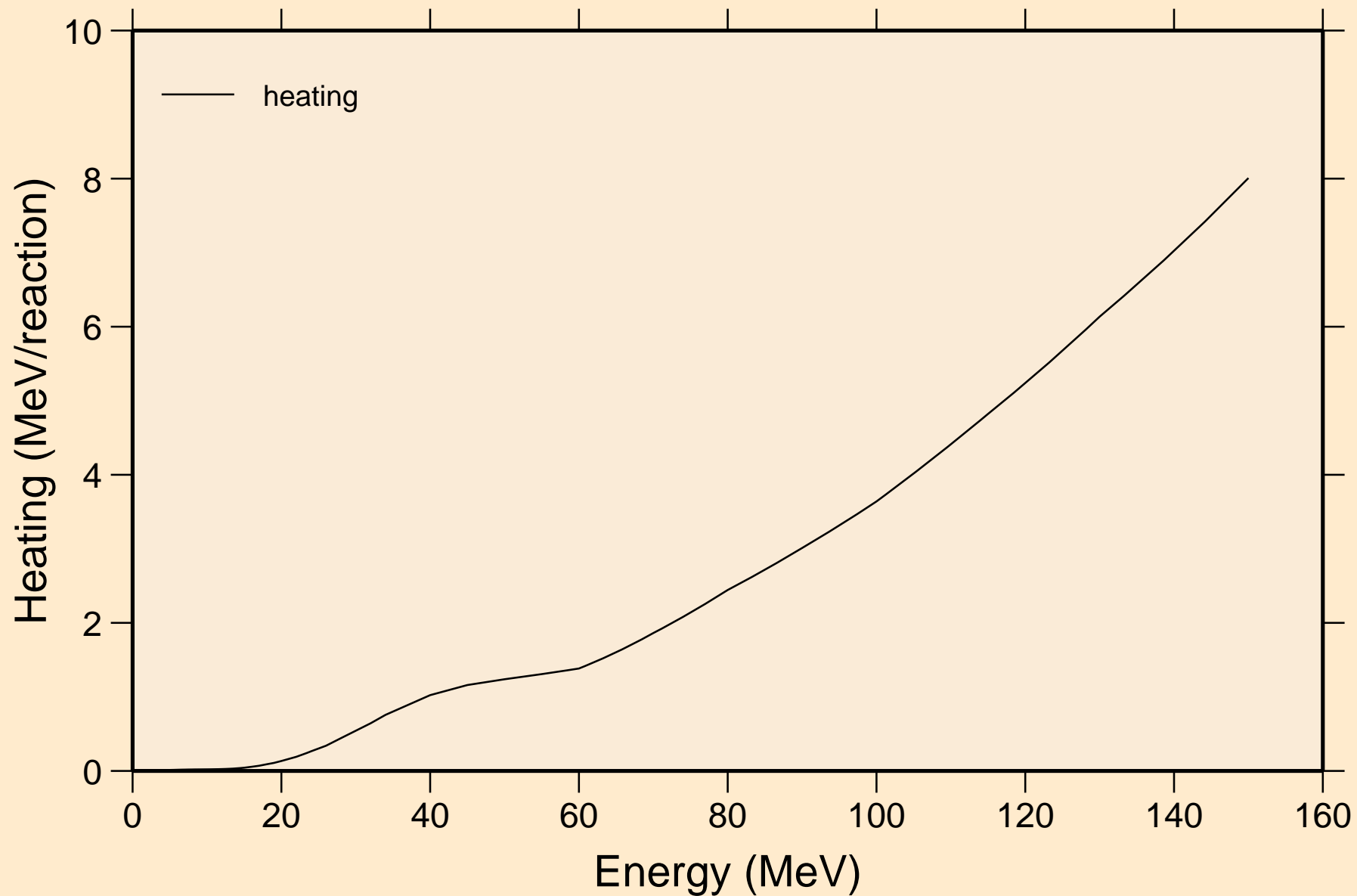

74-W-182 FOR FENDL-3.1 FROM INDL/V-3 WITH NJOY2012.50+ C Damage

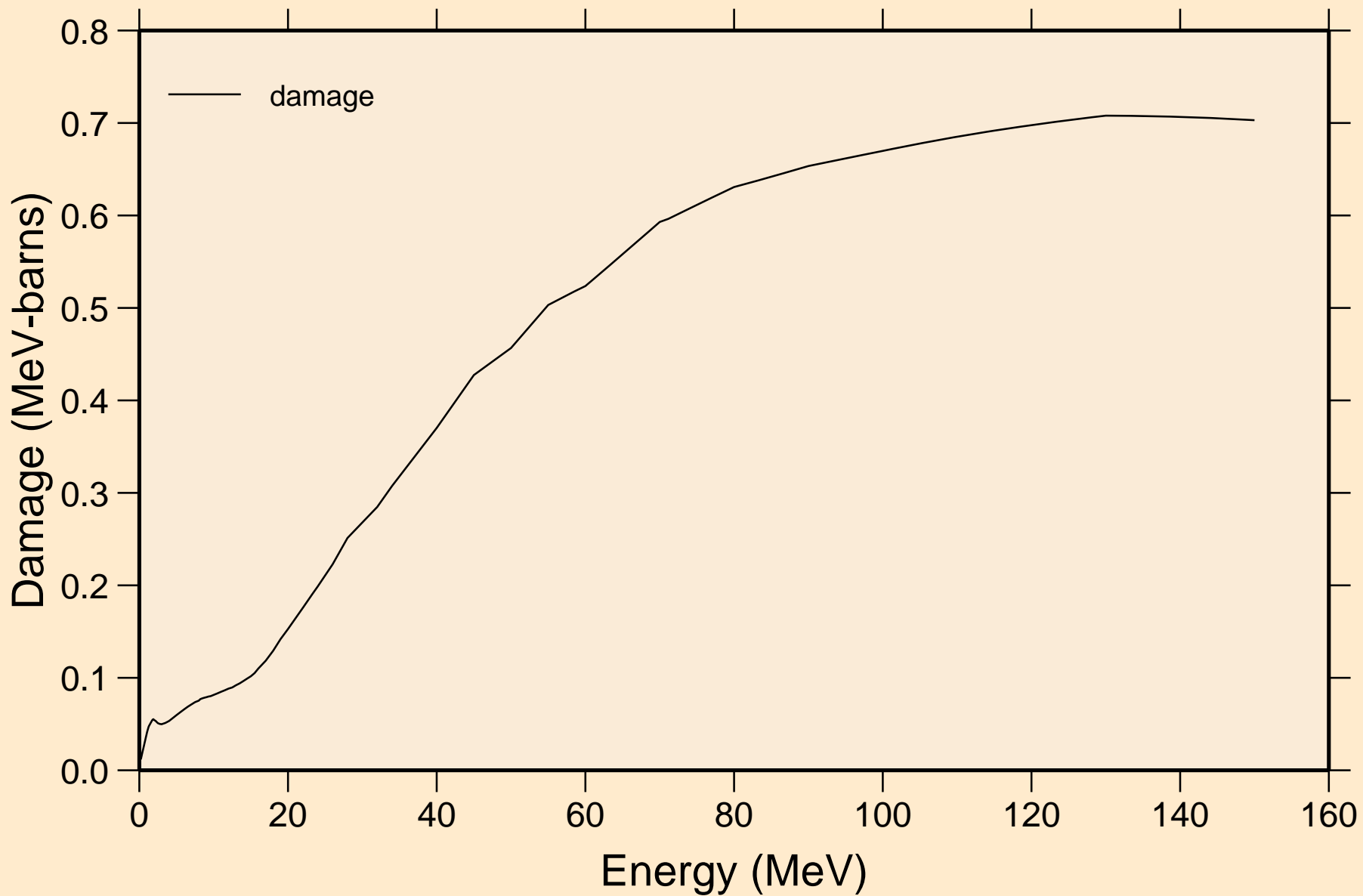

74-W-182 FOR FENDL-3.1 FROM INDL/V-3 WITH NJOY2012.50+ C
Non-threshold reactions

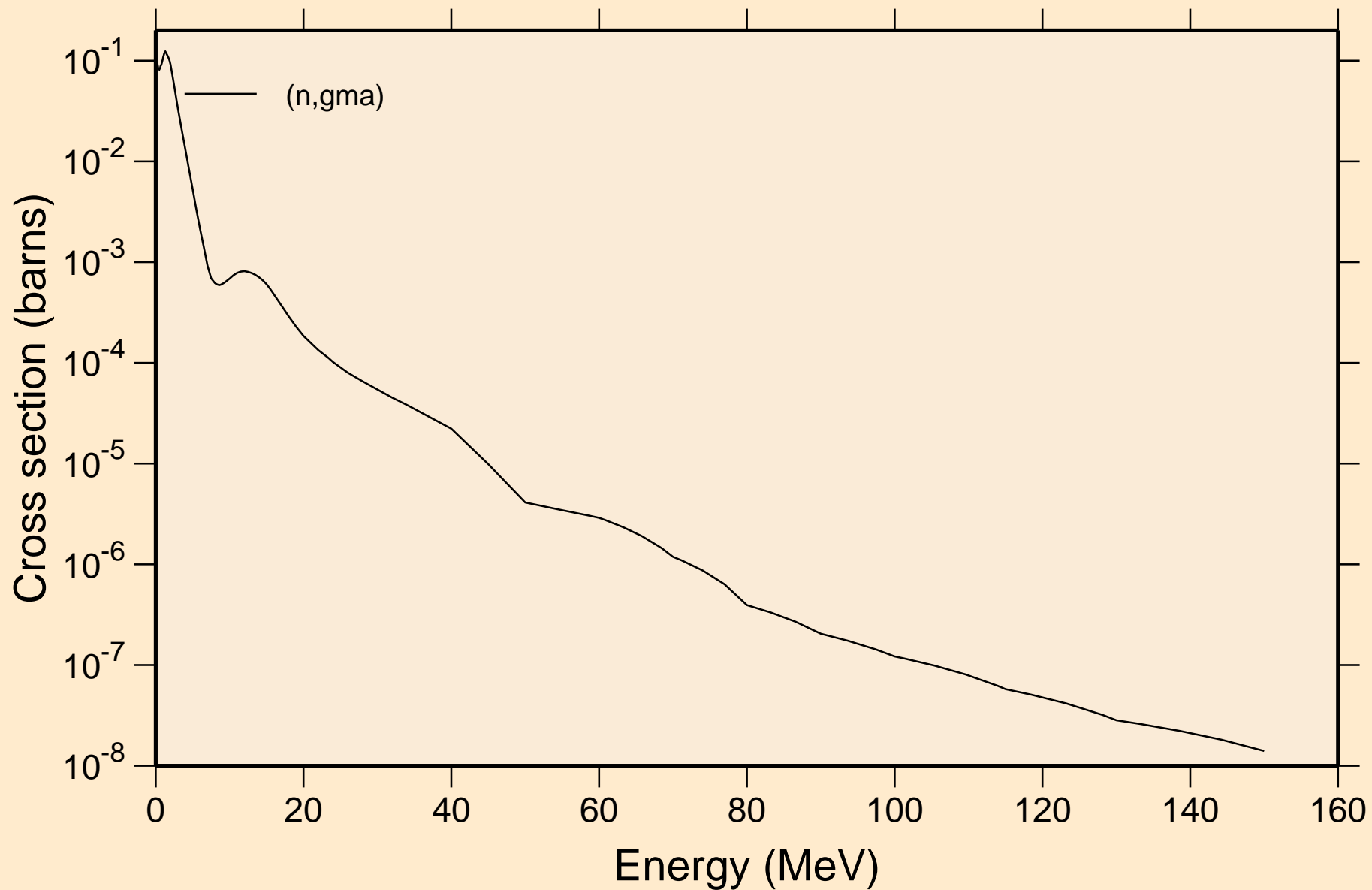

74-W-182 FOR FENDL-3.1 FROM INDL/V-3 WITH NJOY2012.50+ C
Inelastic levels

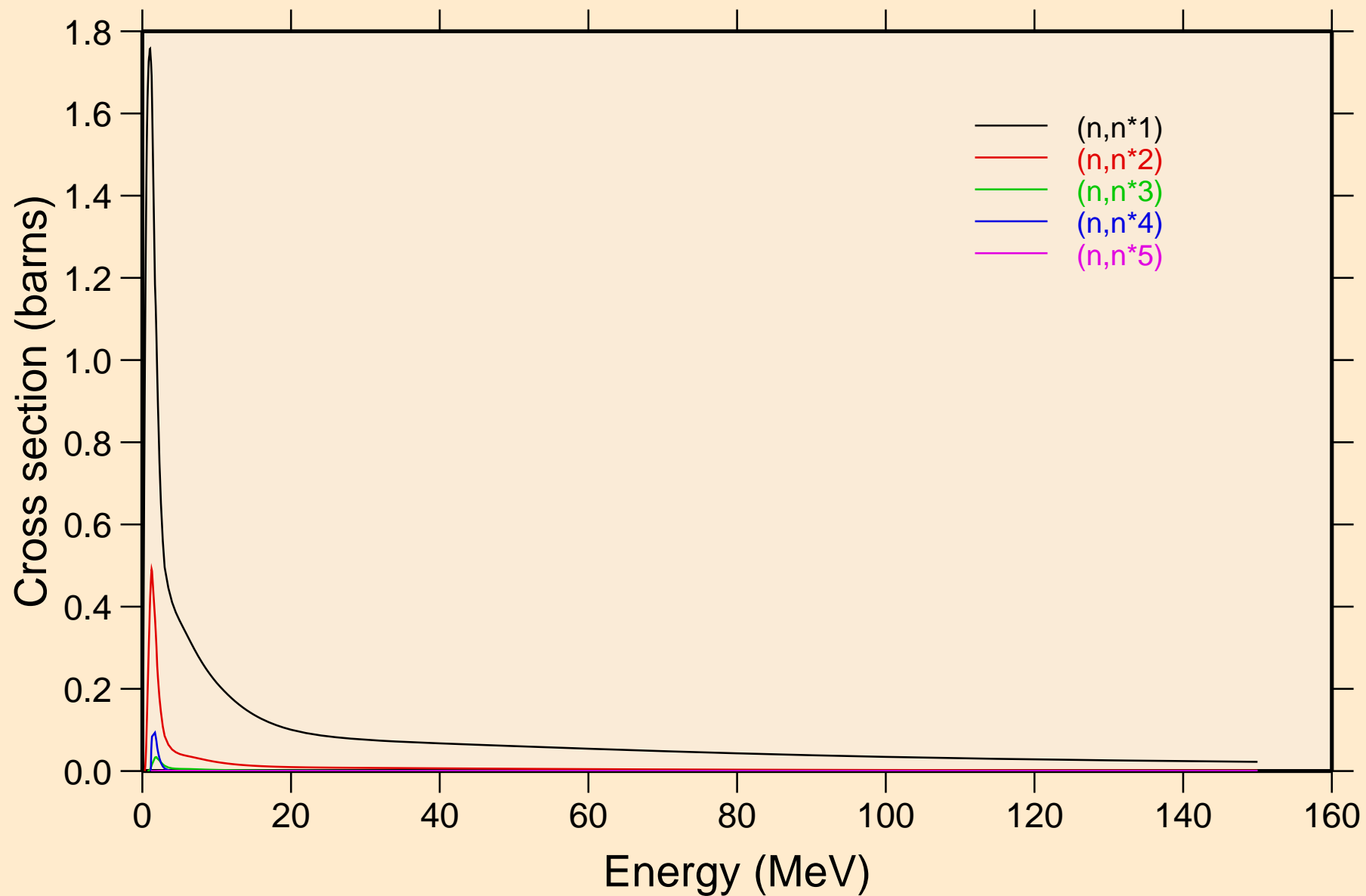

74-W-182 FOR FENDL-3.1 FROM INDL/V-3 WITH NJOY2012.50+ C
Inelastic levels

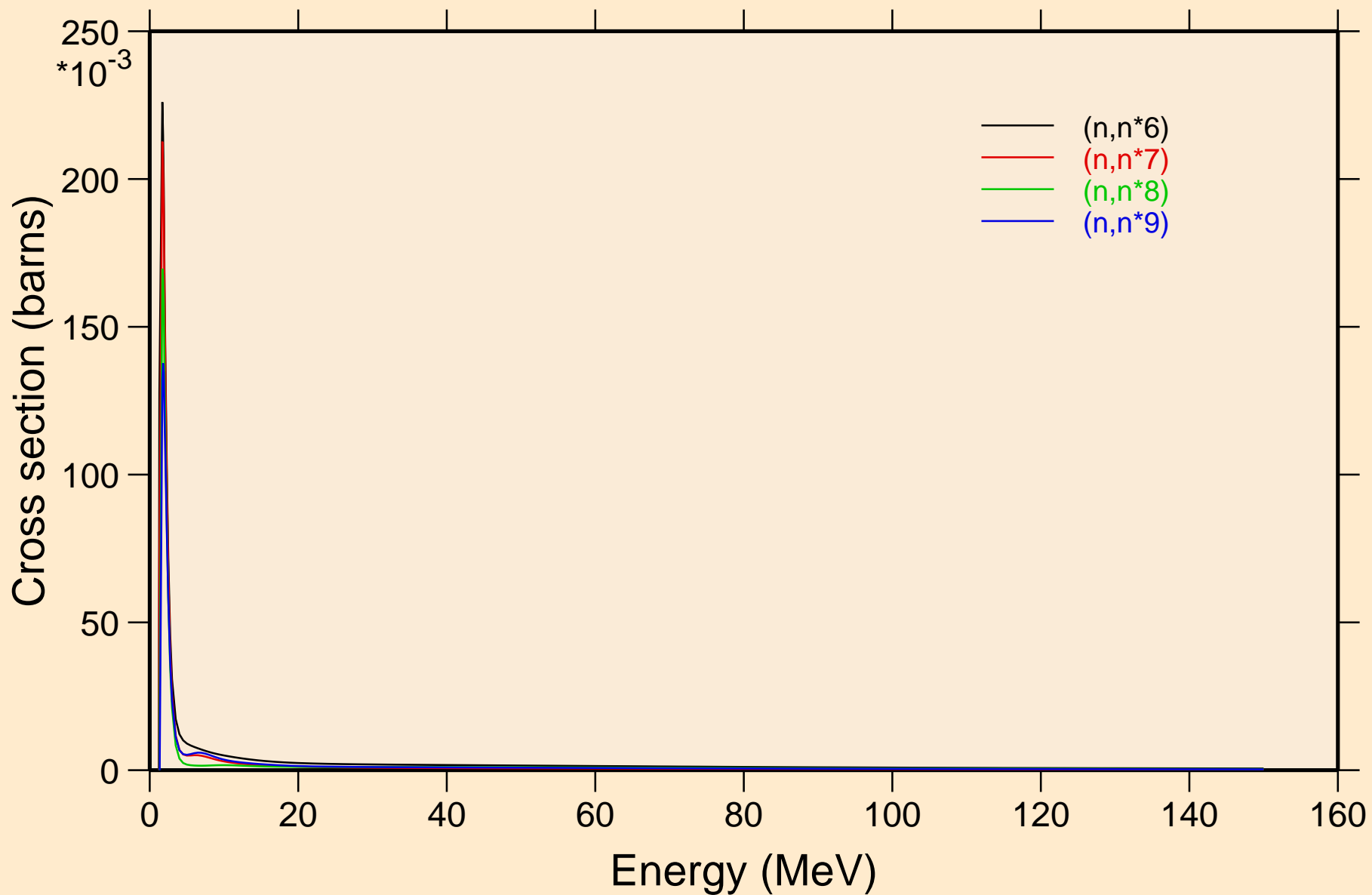

74-W-182 FOR FENDL-3.1 FROM INDL/V-3 WITH NJOY2012.50+ C
Threshold reactions

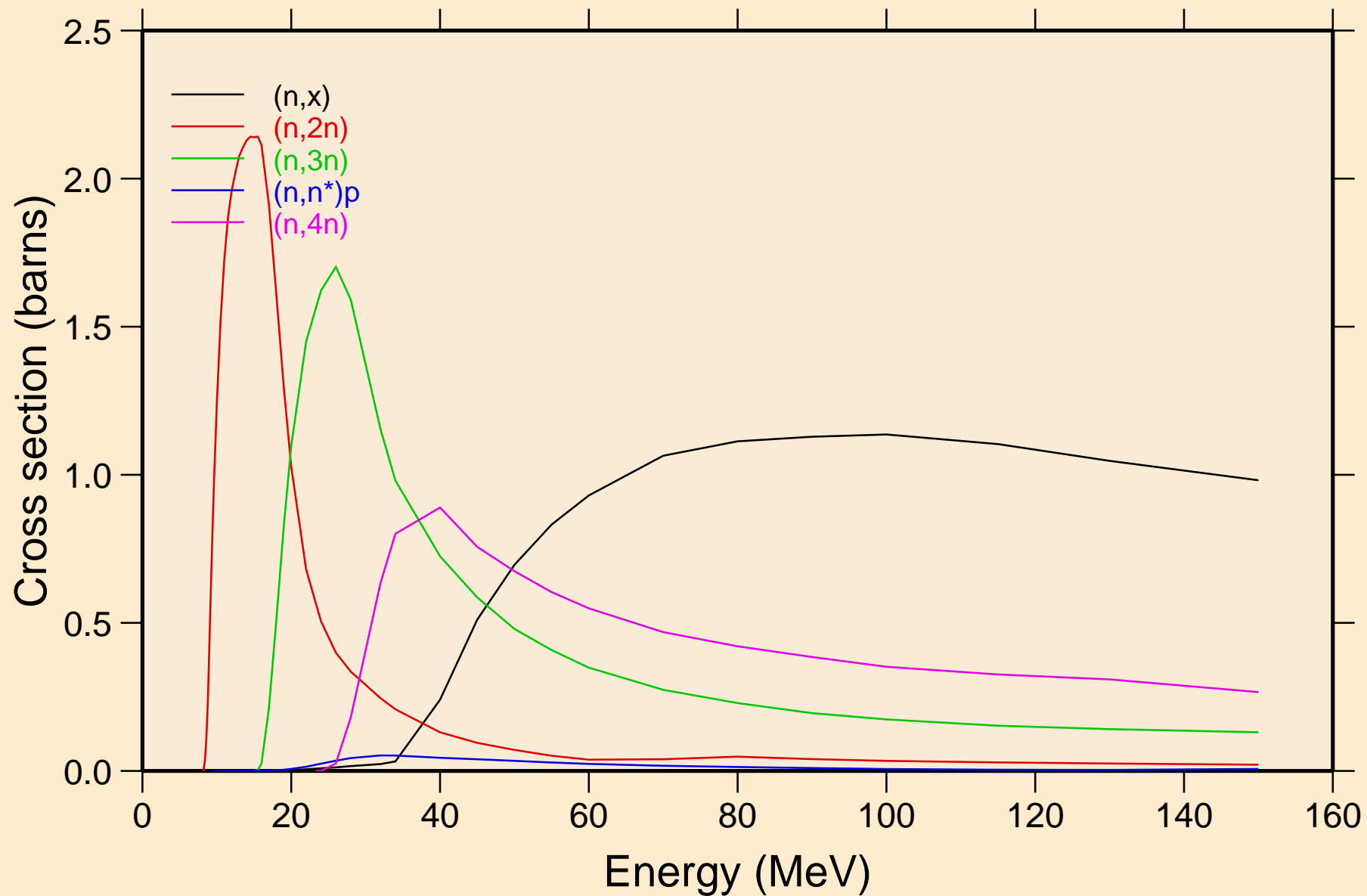

74-W-182 FOR FENDL-3.1 FROM INDL/V-3 WITH NJOY2012.50+ C

Threshold reactions

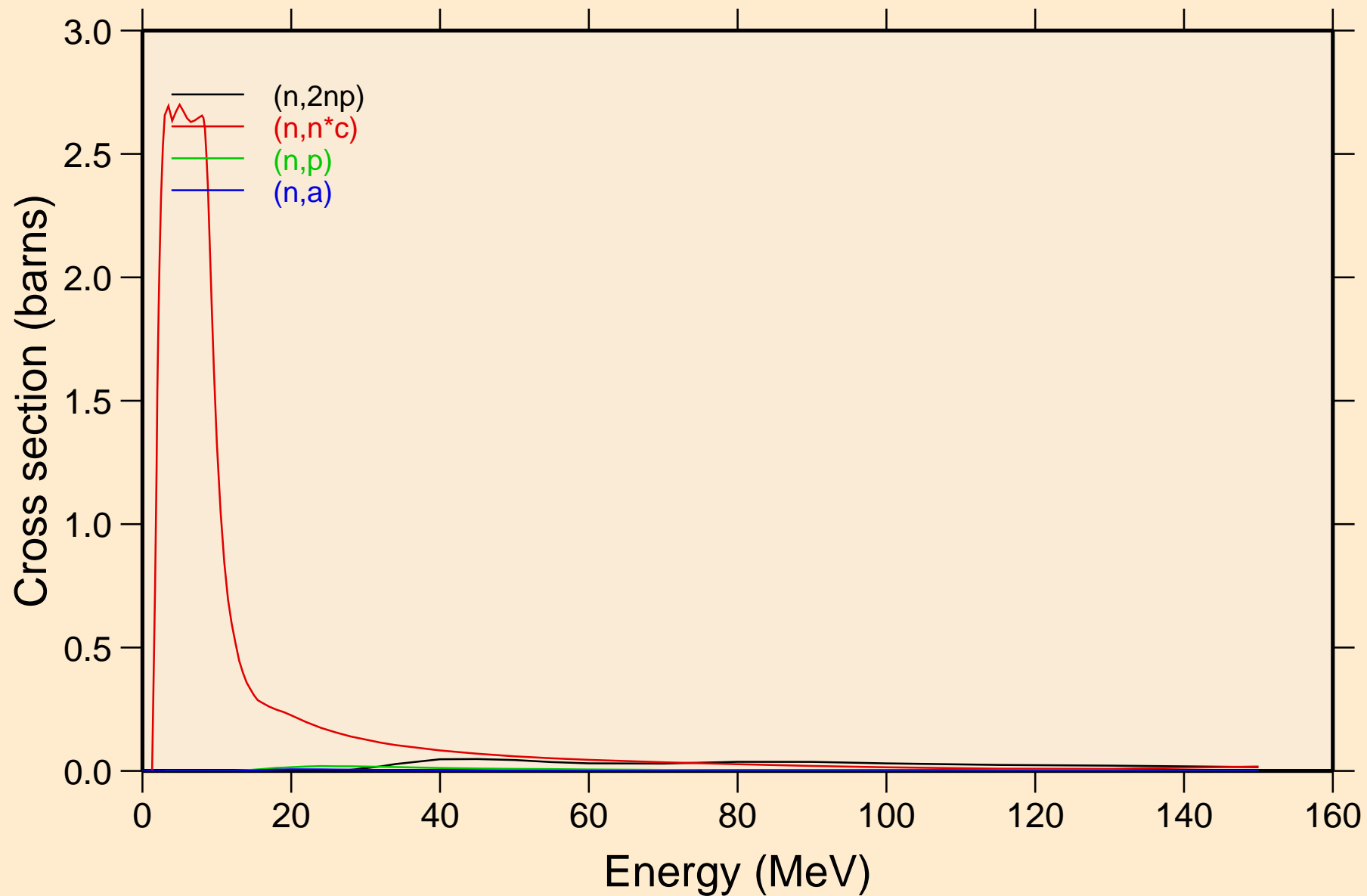

74-W-182 FOR FENDL-3.1 FROM INDL/V-3 WITH NJOY2012.50+ C
Threshold reactions

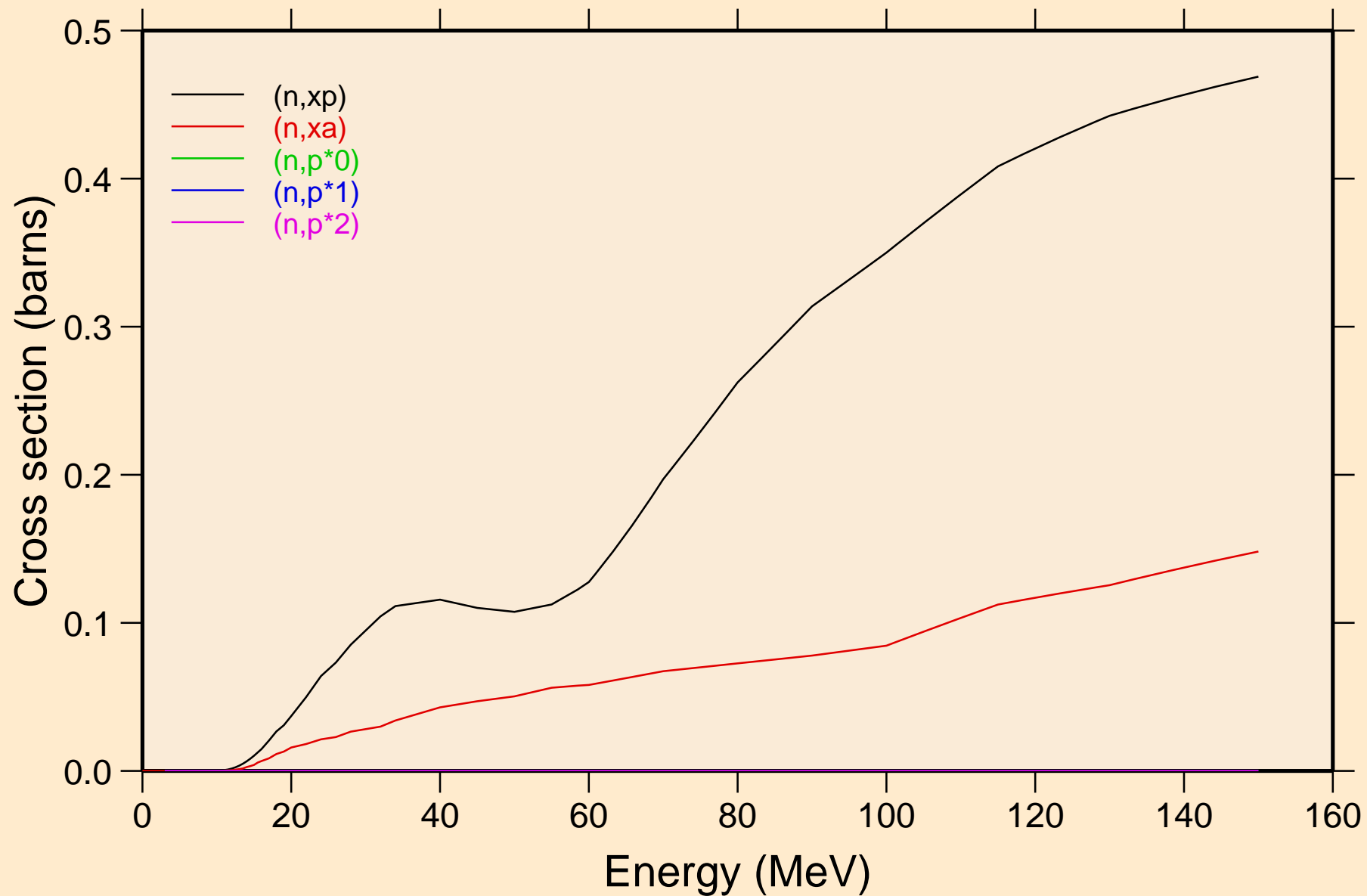

74-W-182 FOR FENDL-3.1 FROM INDL/V-3 WITH NJOY2012.50+ C

Threshold reactions

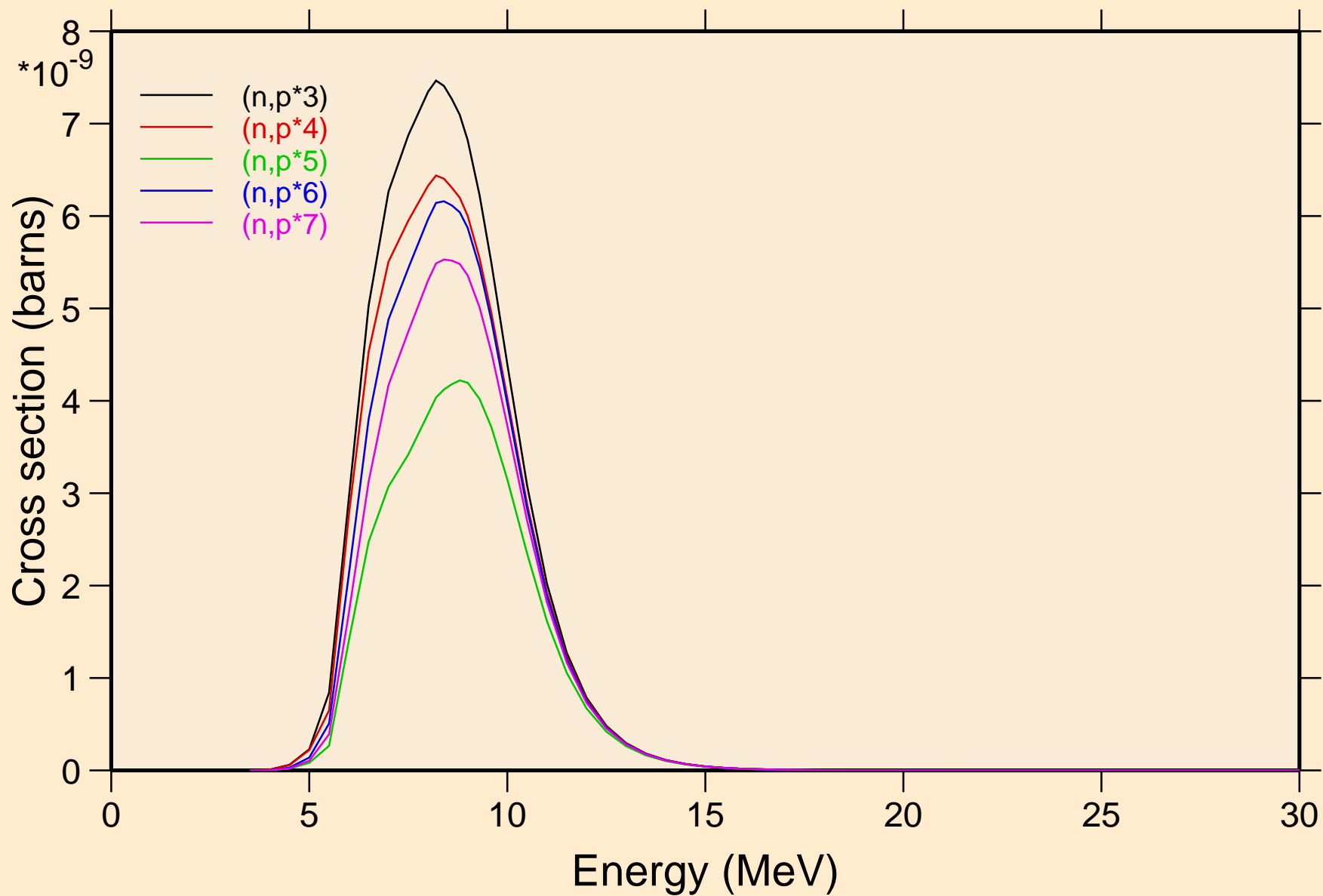

74-W-182 FOR FENDL-3.1 FROM INDL/V-3 WITH NJOY2012.50+ C

Threshold reactions

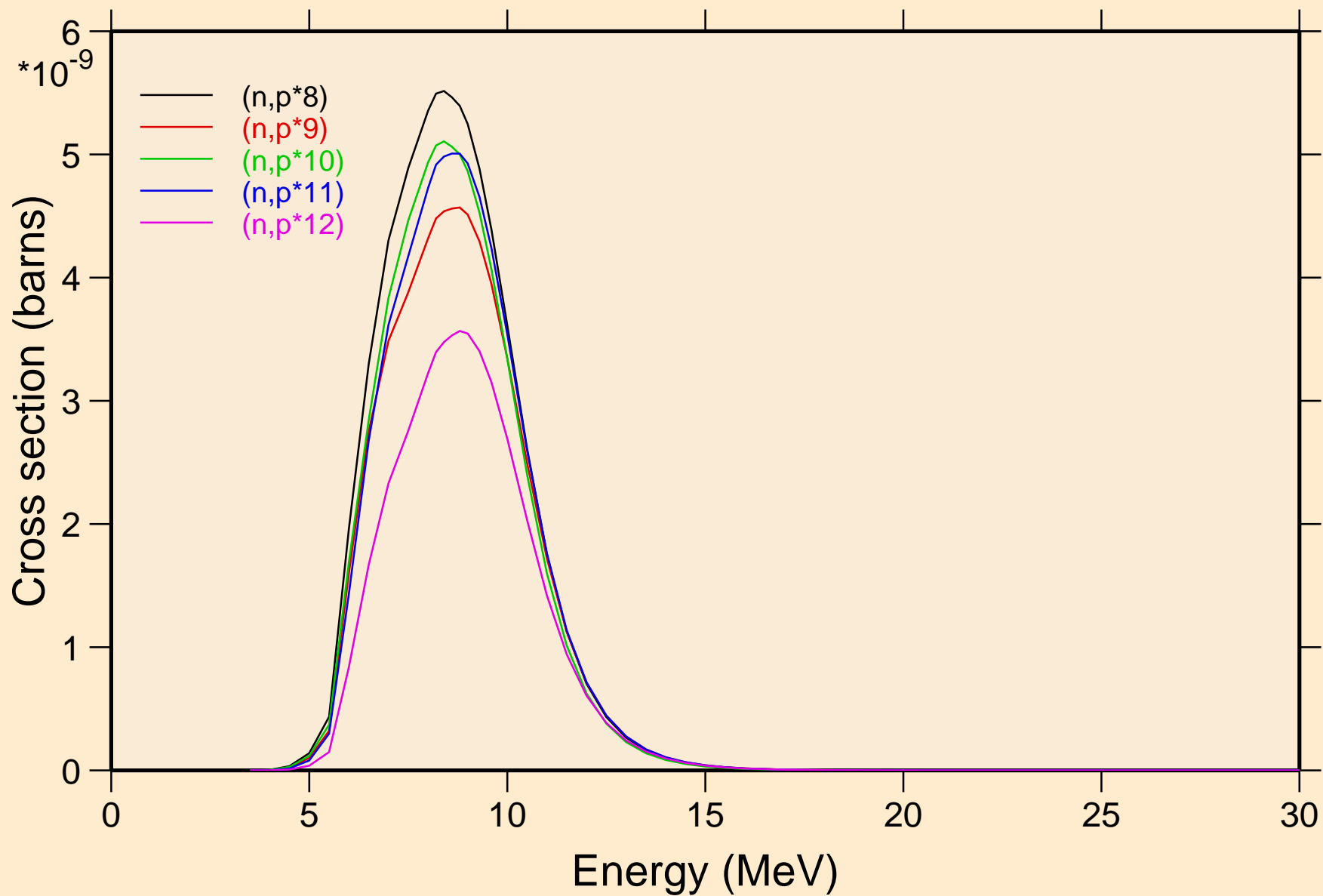

74-W-182 FOR FENDL-3.1 FROM INDL/V-3 WITH NJOY2012.50+ C

Threshold reactions

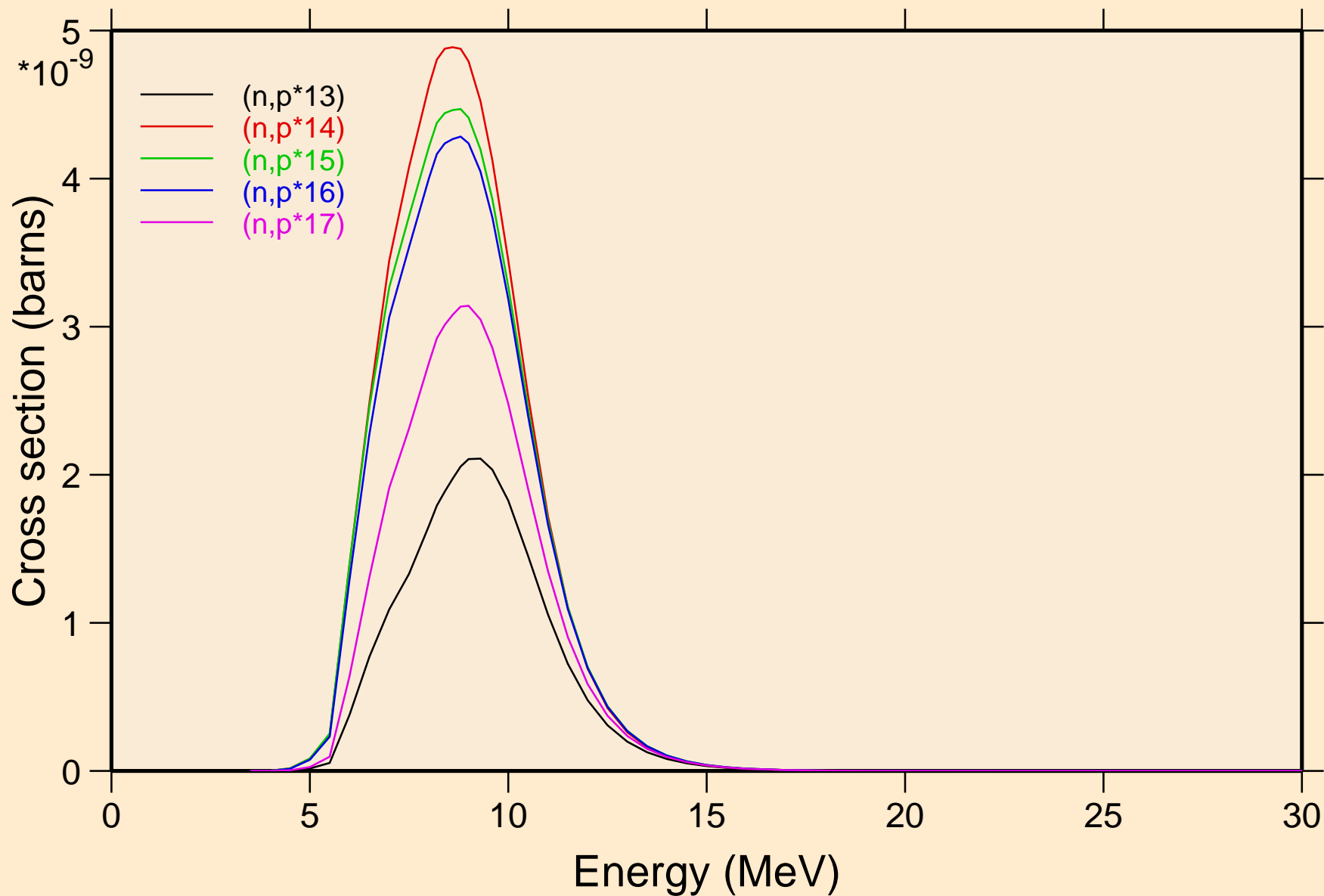

74-W-182 FOR FENDL-3.1 FROM INDL/V-3 WITH NJOY2012.50+ C

Threshold reactions

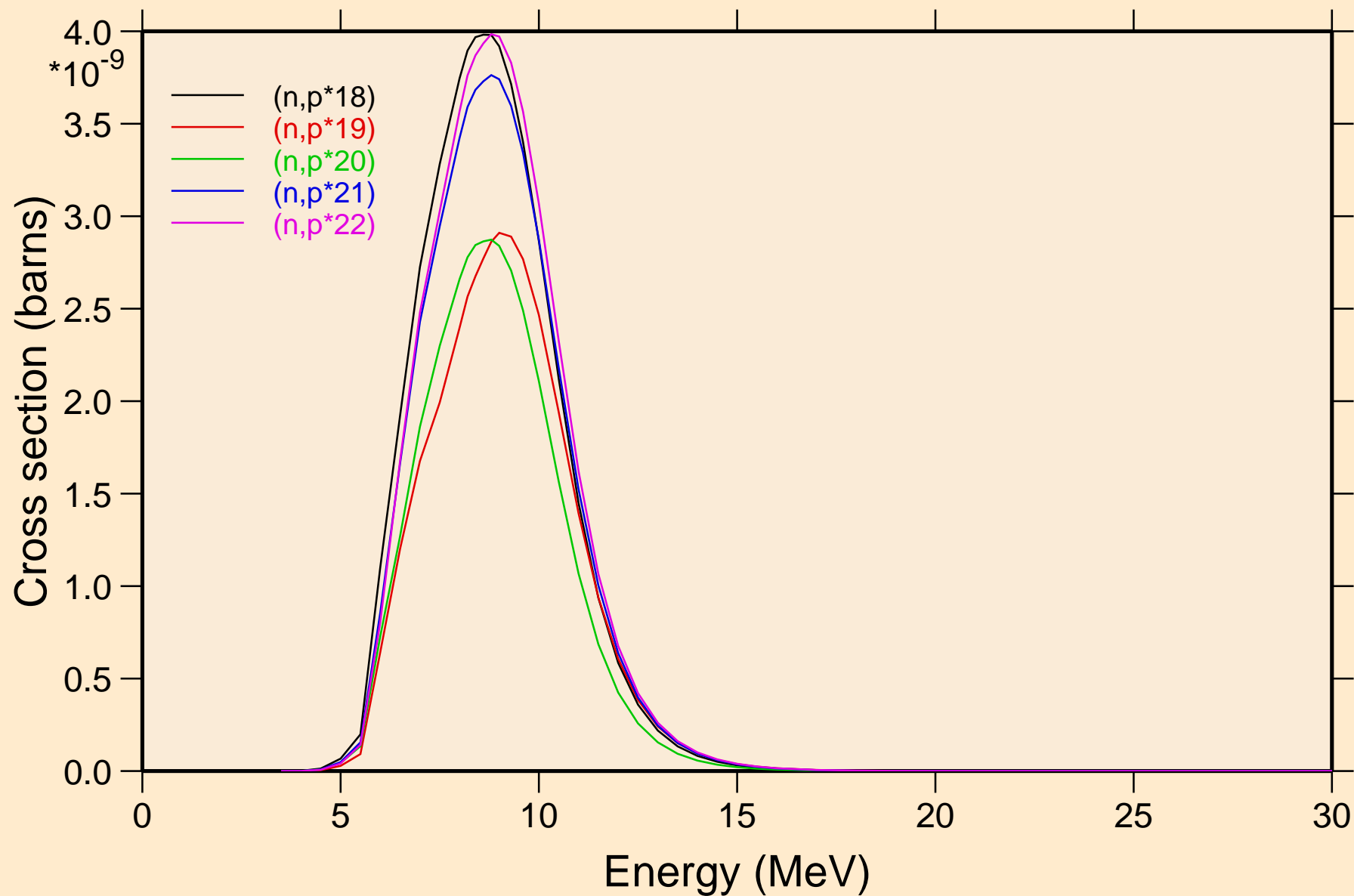

74-W-182 FOR FENDL-3.1 FROM INDL/V-3 WITH NJOY2012.50+ C

Threshold reactions

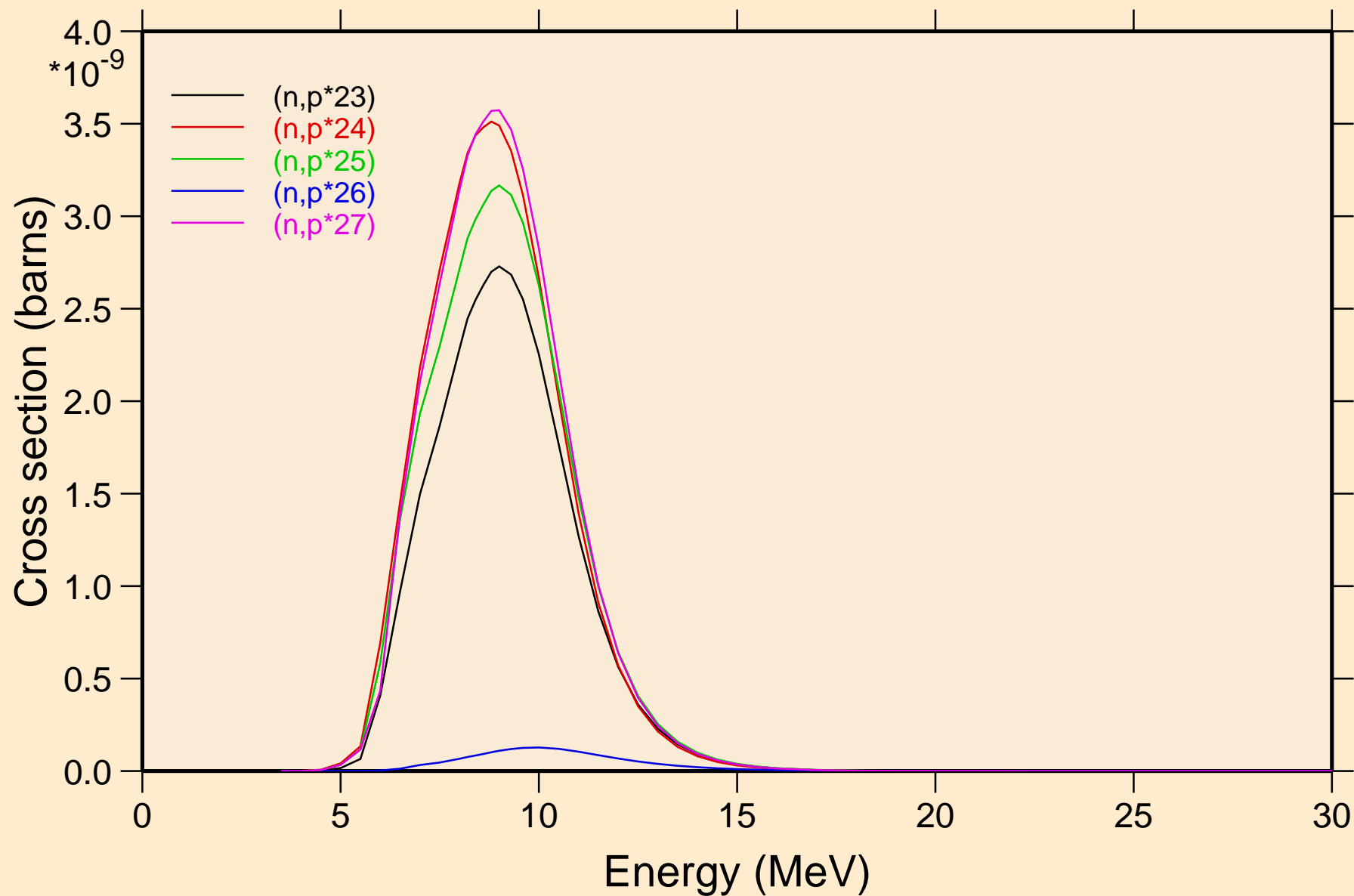

74-W-182 FOR FENDL-3.1 FROM INDL/V-3 WITH NJOY2012.50+ C

Threshold reactions

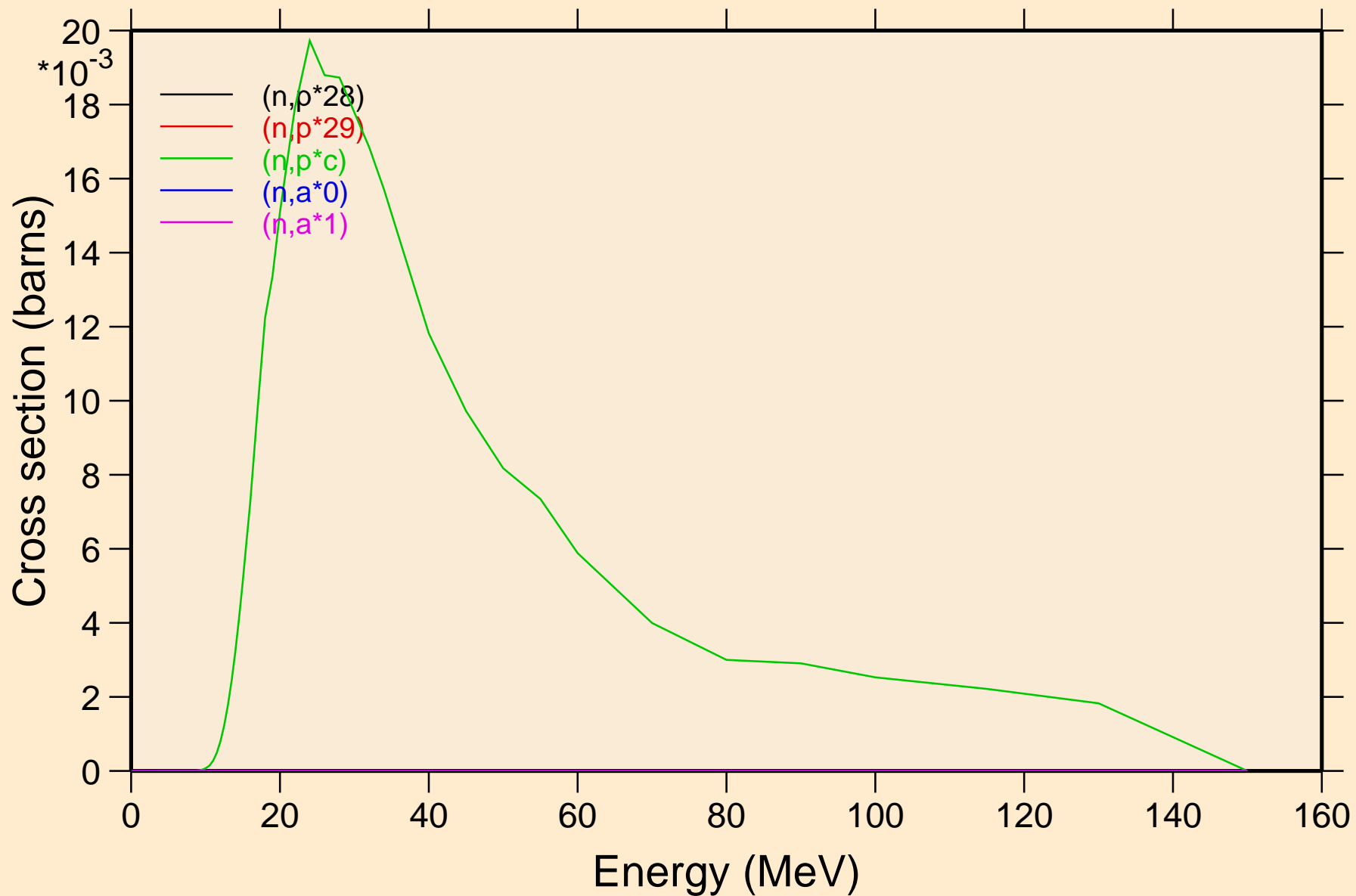

74-W-182 FOR FENDL-3.1 FROM INDL/V-3 WITH NJOY2012.50+ C

Threshold reactions

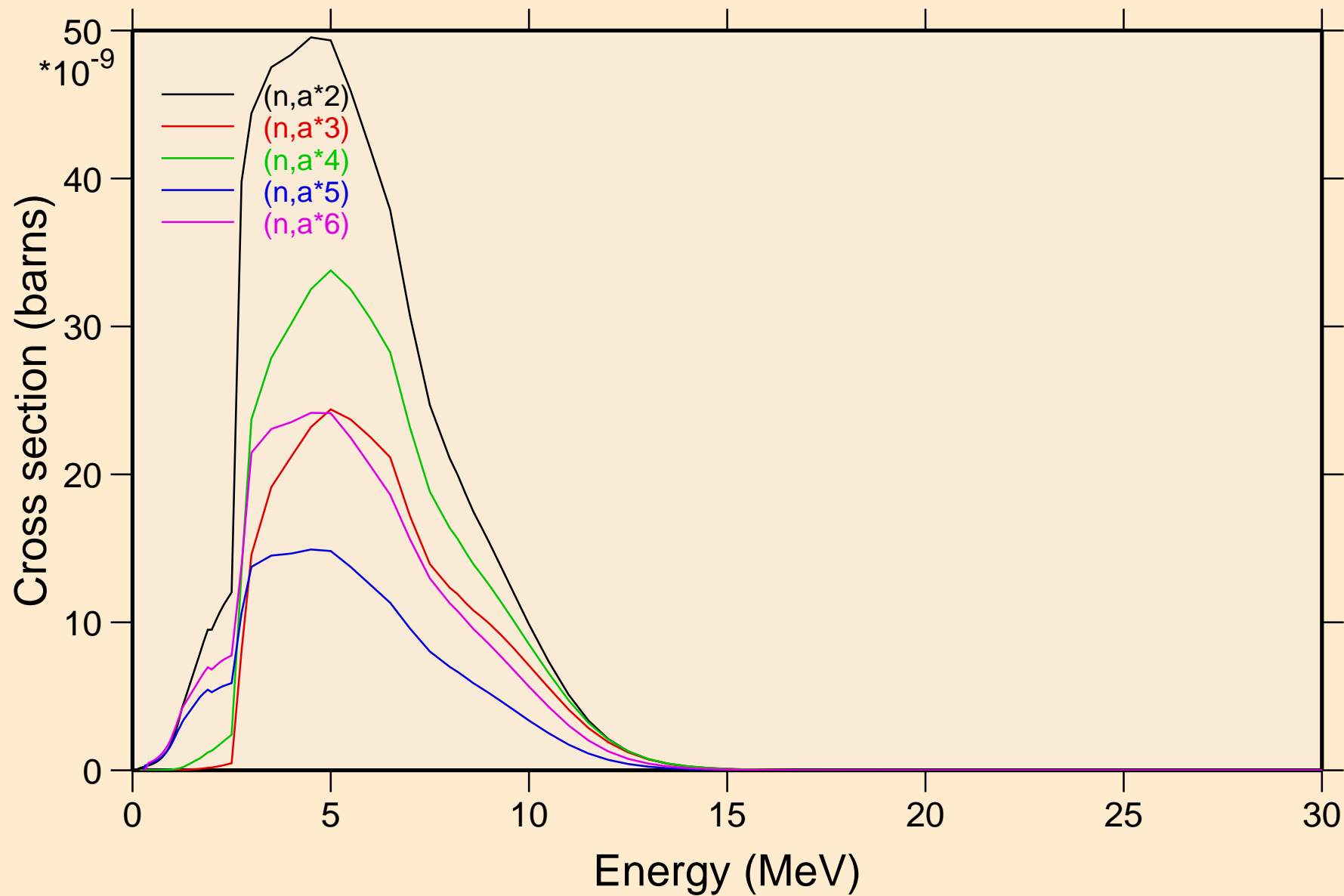

74-W-182 FOR FENDL-3.1 FROM INDL/V-3 WITH NJOY2012.50+ C
Threshold reactions

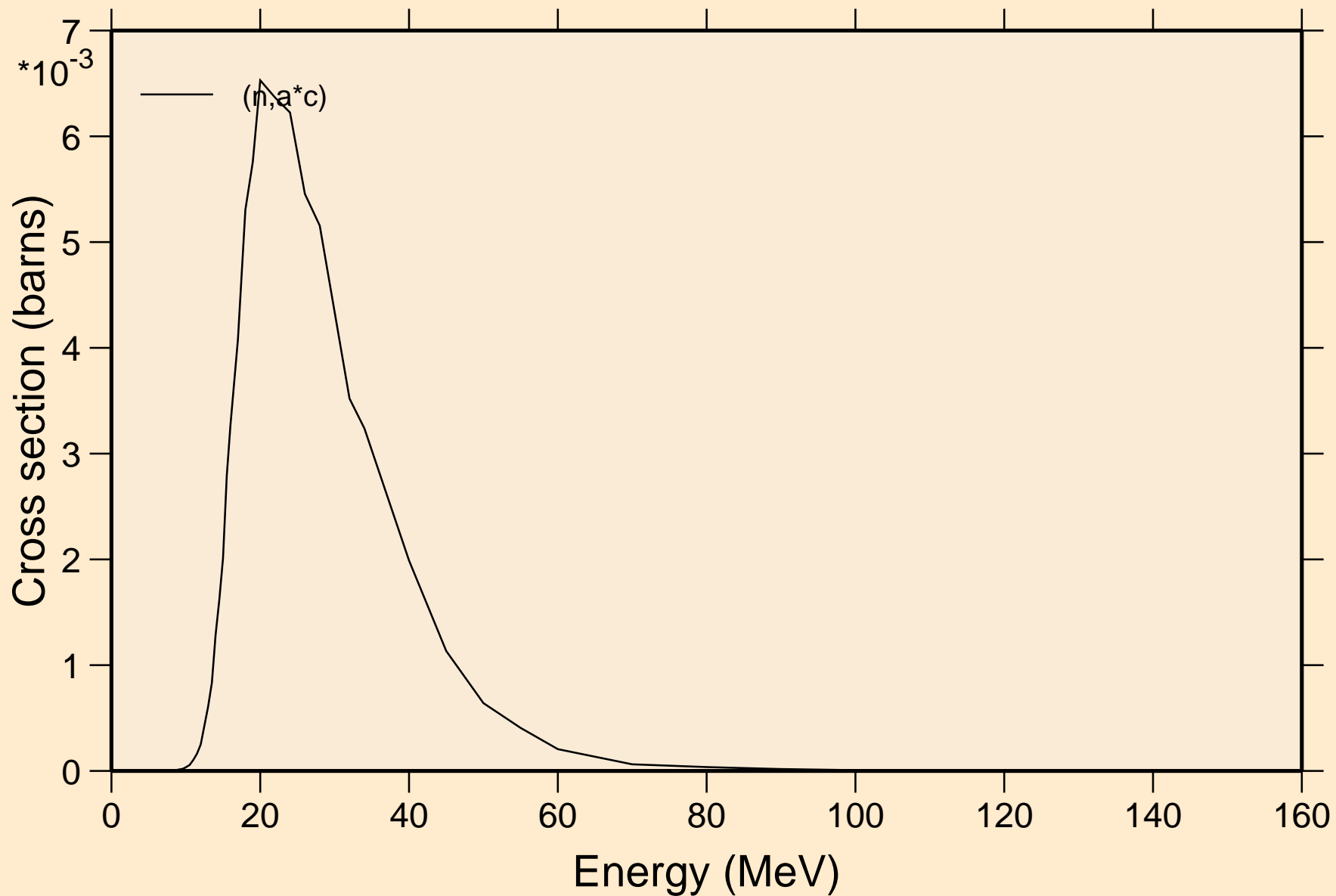

74-W-182 FOR FENDL-3.1 FROM INDL/V-3 WITH NJOY2012.50+ C
angular distribution for elastic

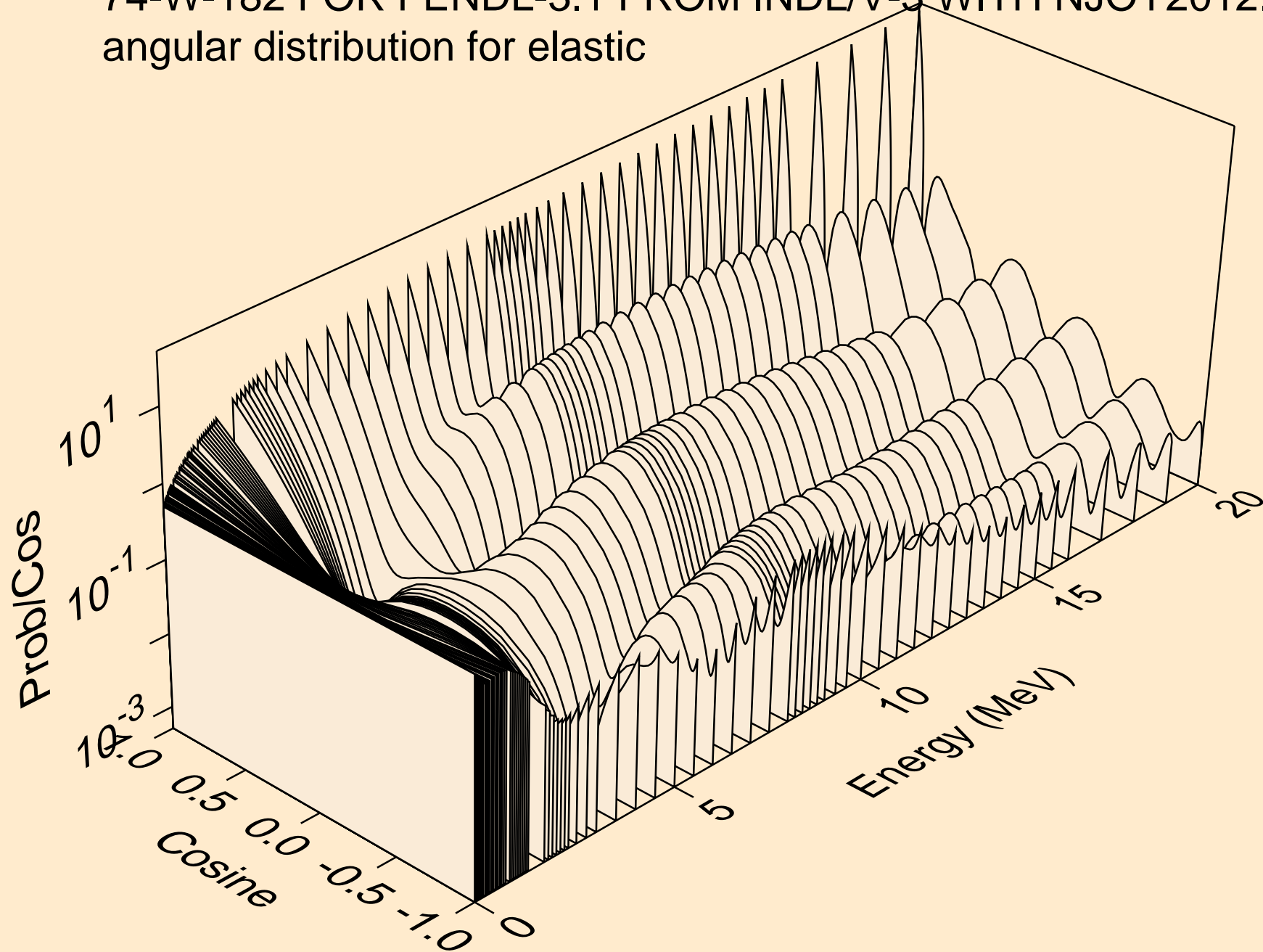

74-W-182 FOR FENDL-3.1 FROM INDL/V-3 WITH NJOY2012.50+ C
angular distribution for elastic

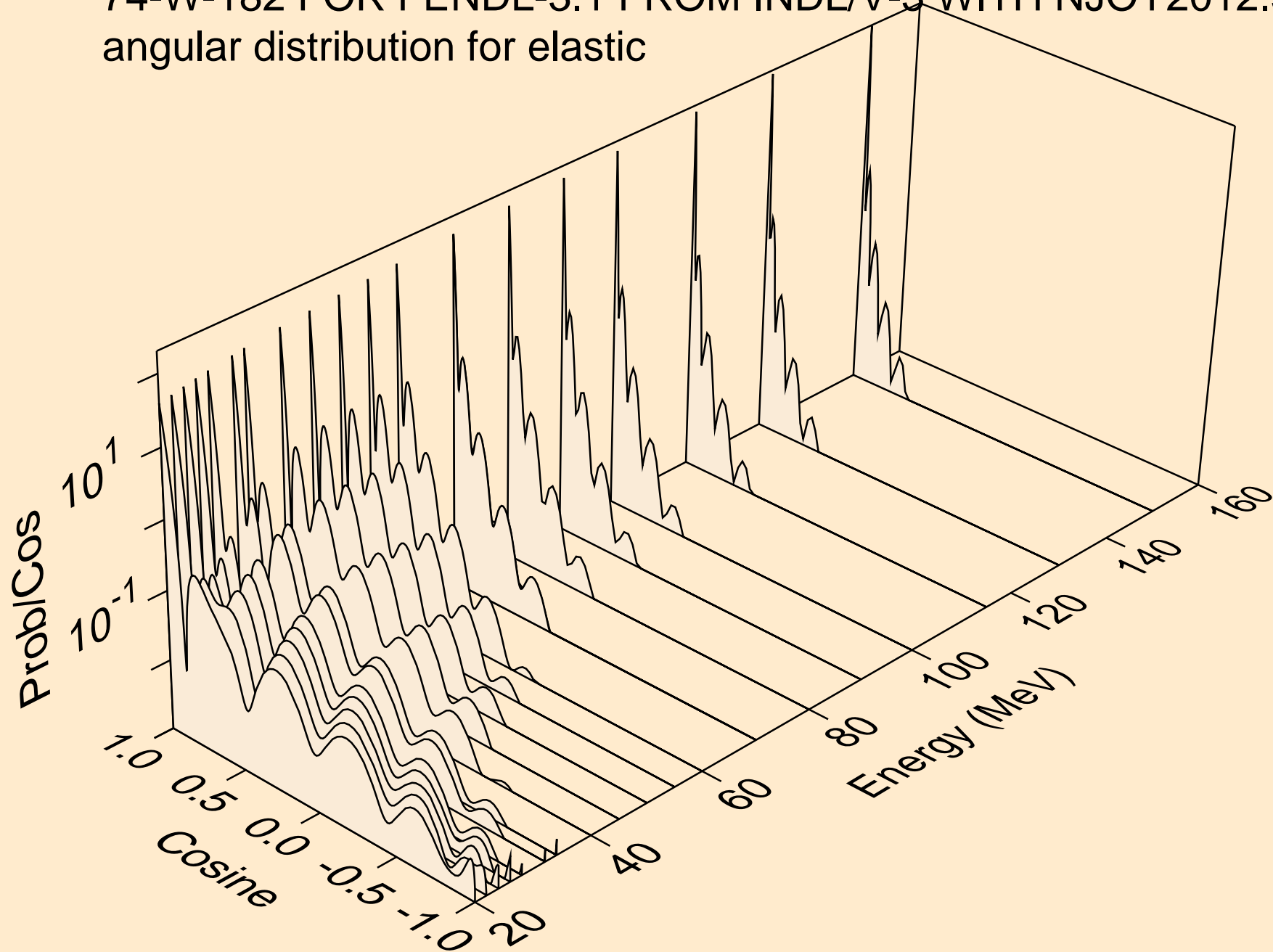

74-W-182 FOR FENDL-3.1 FROM INDL/V-3 WITH NJOY2012.50+ C
angular distribution for (n,n*1)

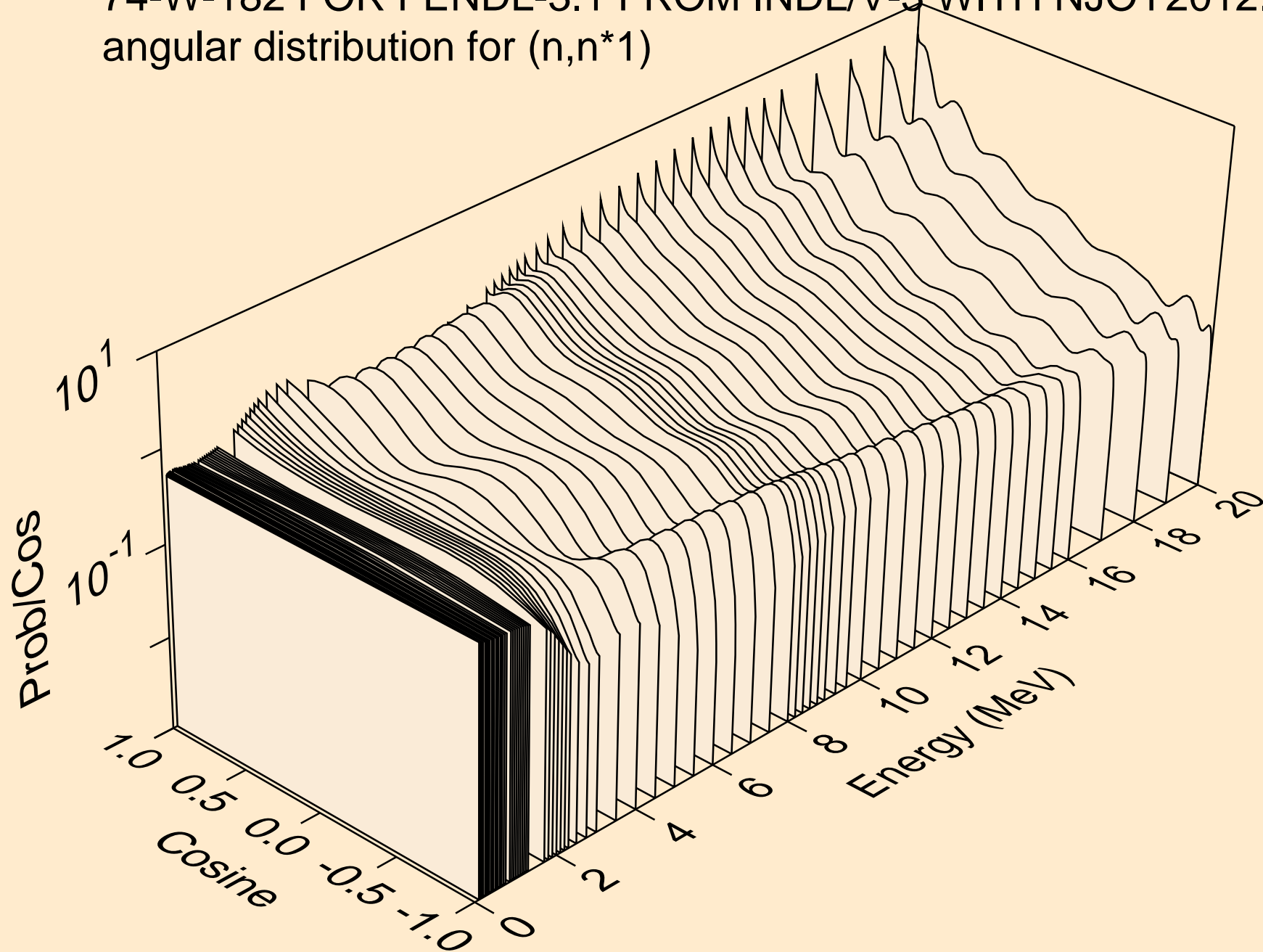

74-W-182 FOR FENDL-3.1 FROM INDL/V-3 WITH NJOY2012.50+ C
angular distribution for (n,n*1)

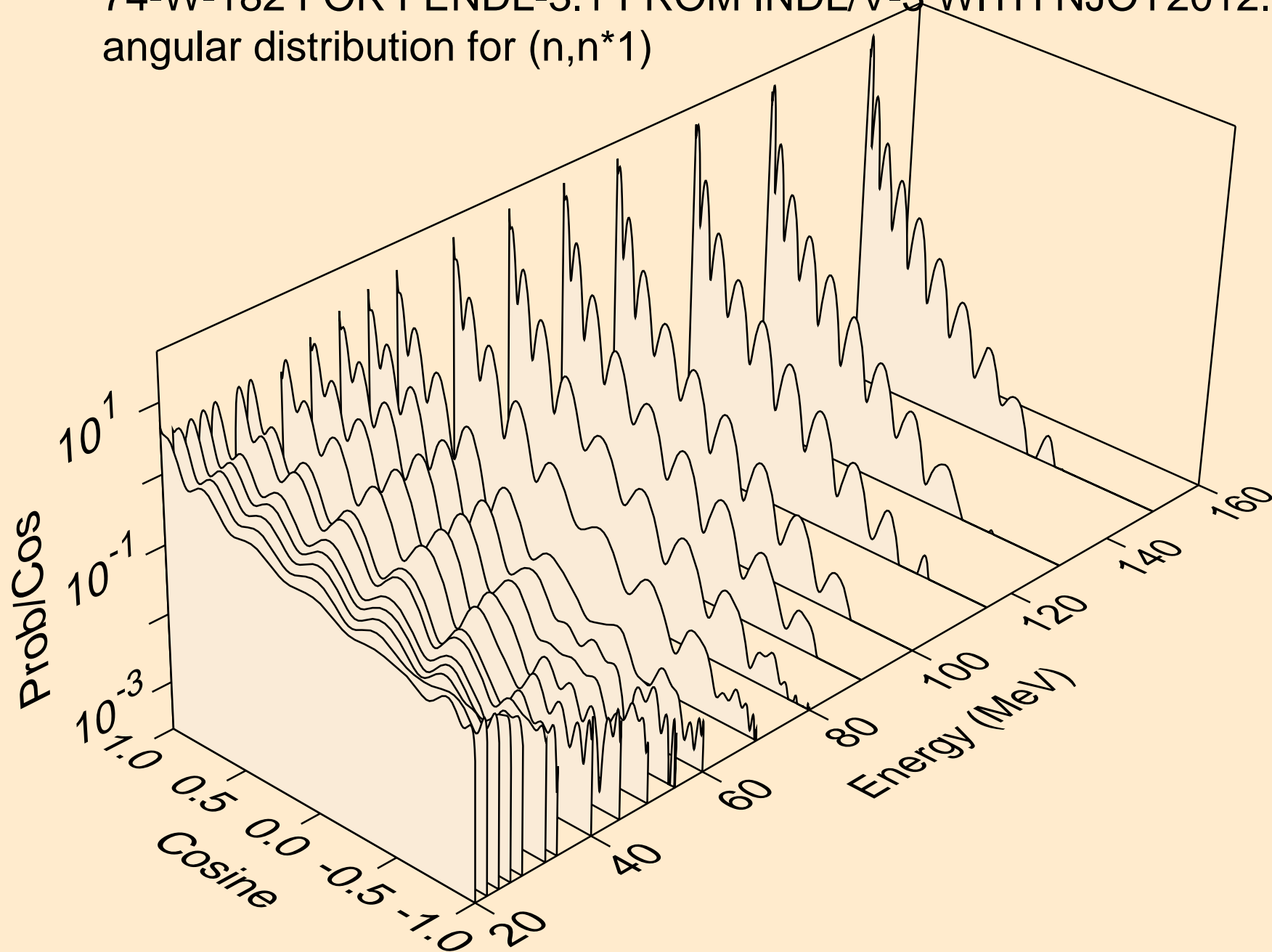

74-W-182 FOR FENDL-3.1 FROM INDL/V-3 WITH NJOY2012.50+ C
angular distribution for (n,n*2)

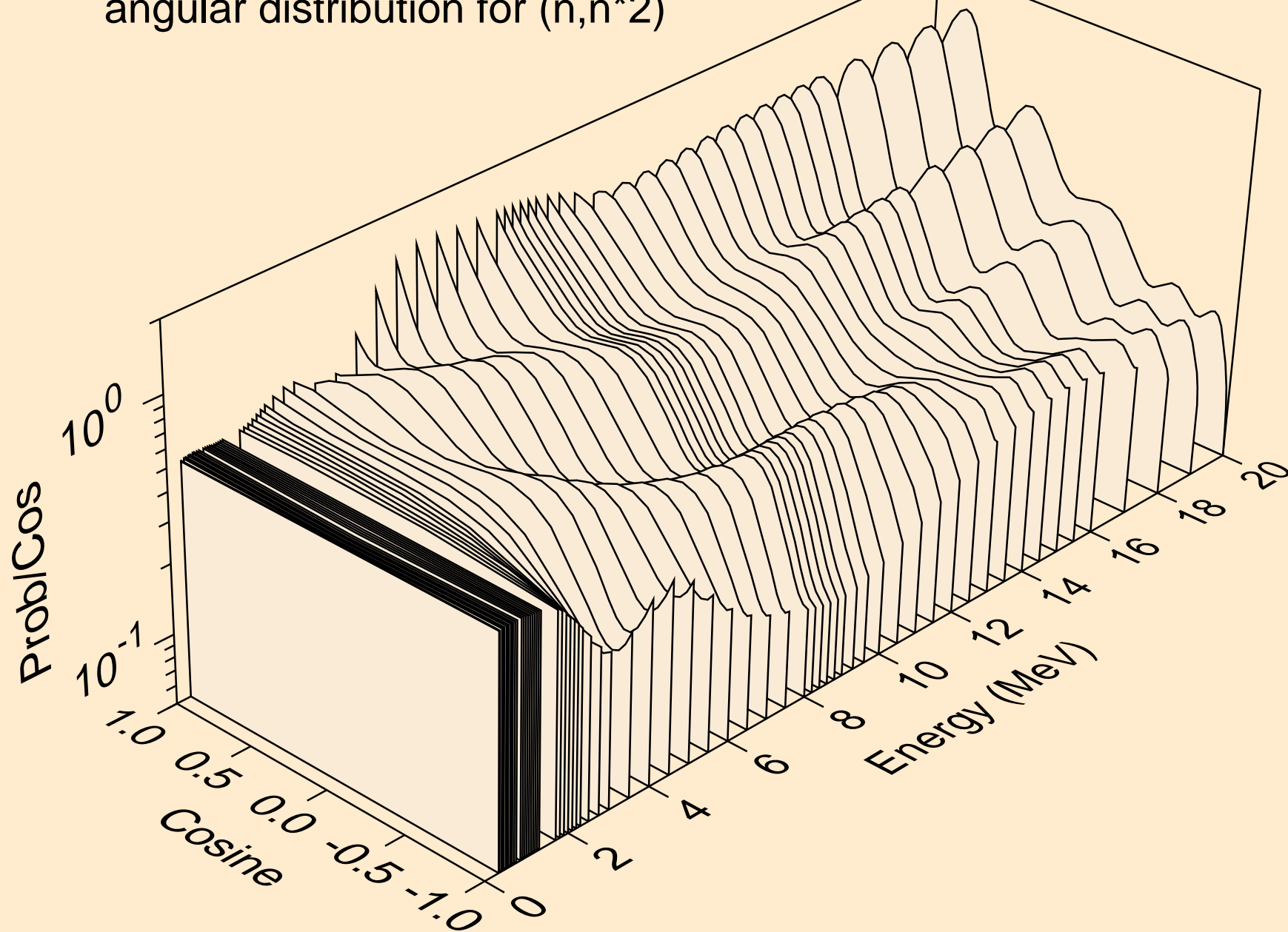

74-W-182 FOR FENDL-3.1 FROM INDL/V-3 WITH NJOY2012.50+ C
angular distribution for (n,n*2)

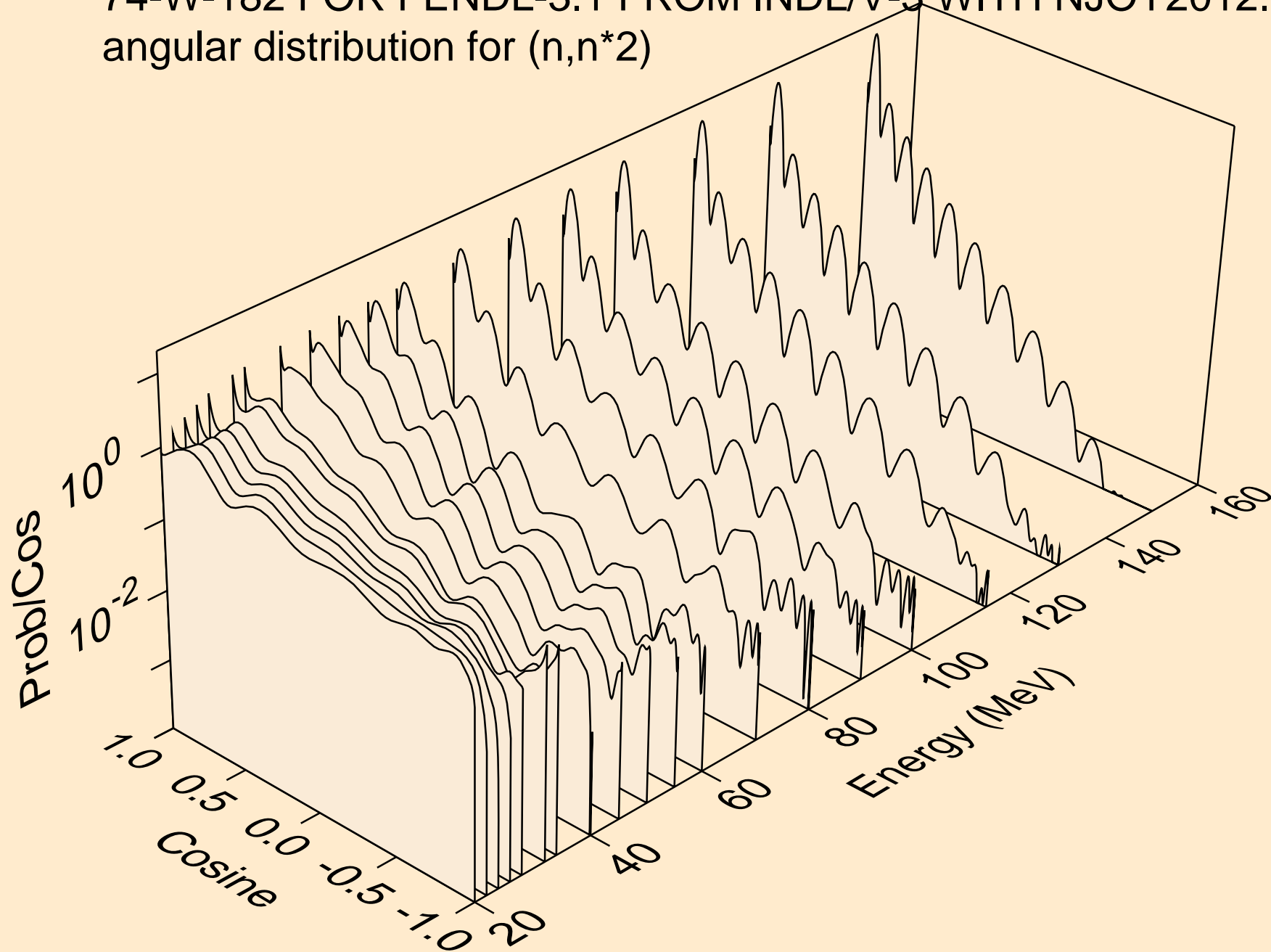

74-W-182 FOR FENDL-3.1 FROM INDL/V-3 WITH NJOY2012.50+ C
angular distribution for (n,n*3)

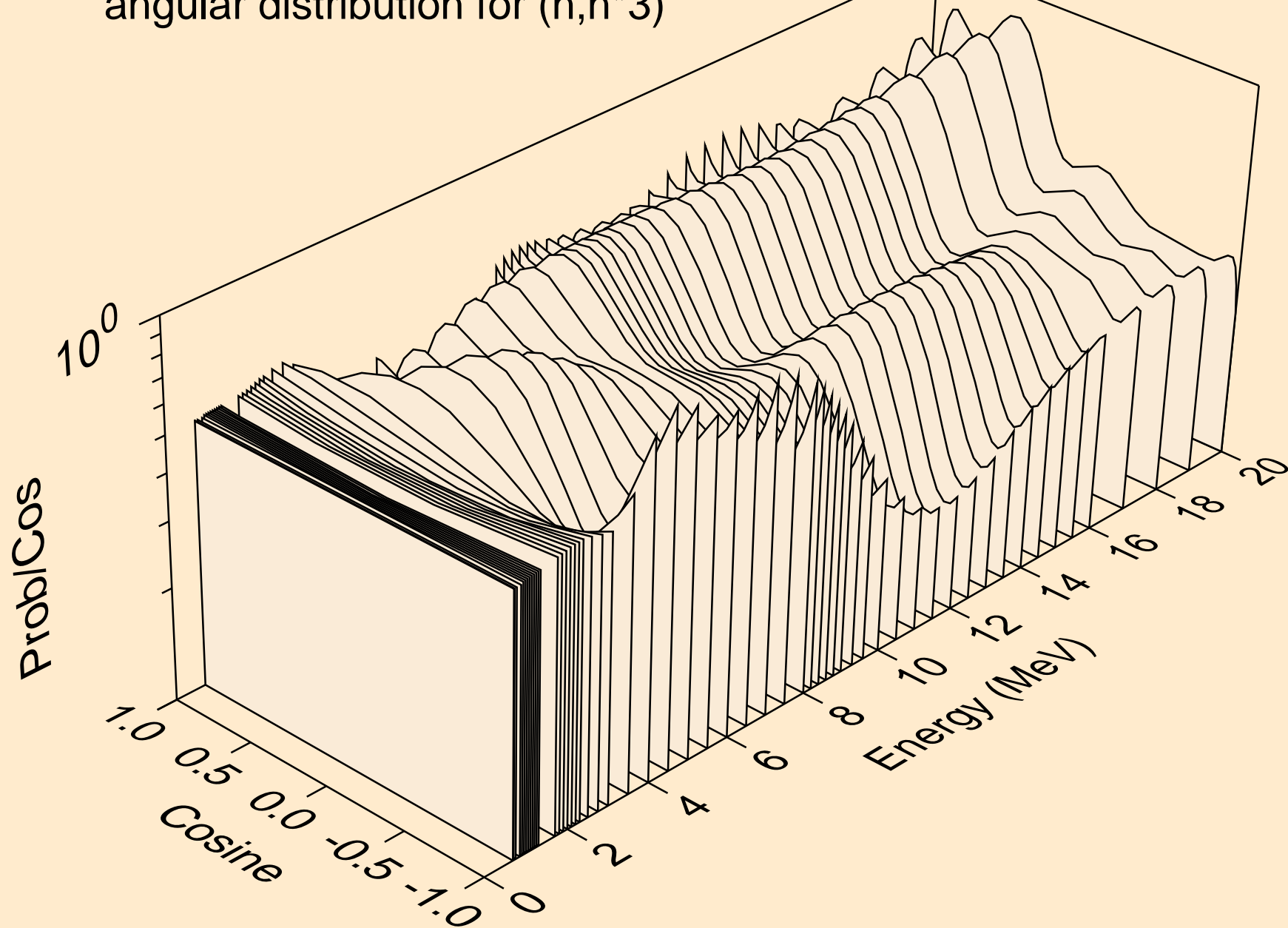

74-W-182 FOR FENDL-3.1 FROM INDL/V-3 WITH NJOY2012.50+ C
angular distribution for (n,n*3)

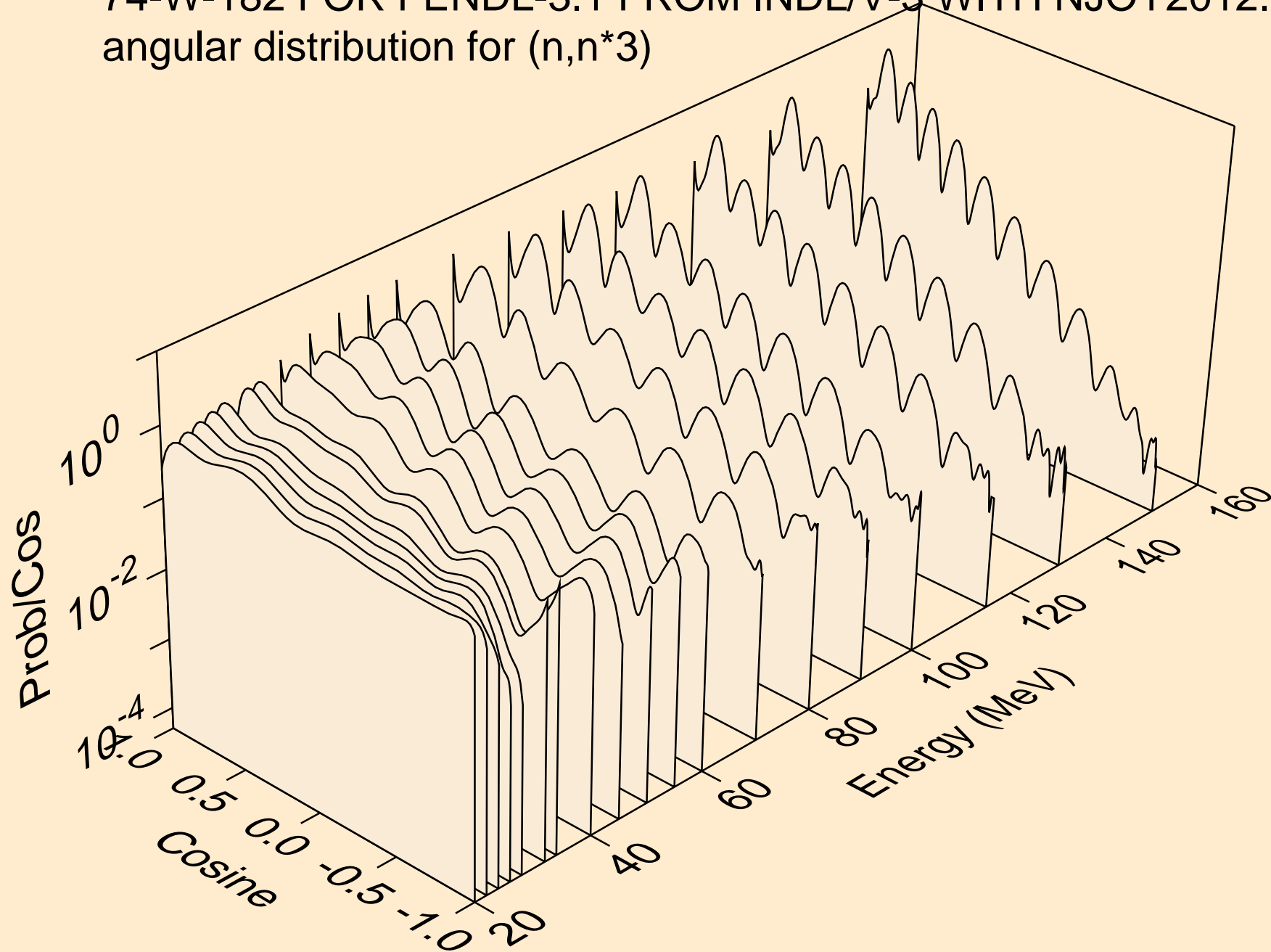

74-W-182 FOR FENDL-3.1 FROM INDL/V-3 WITH NJOY2012.50+ C
angular distribution for (n,n*4)

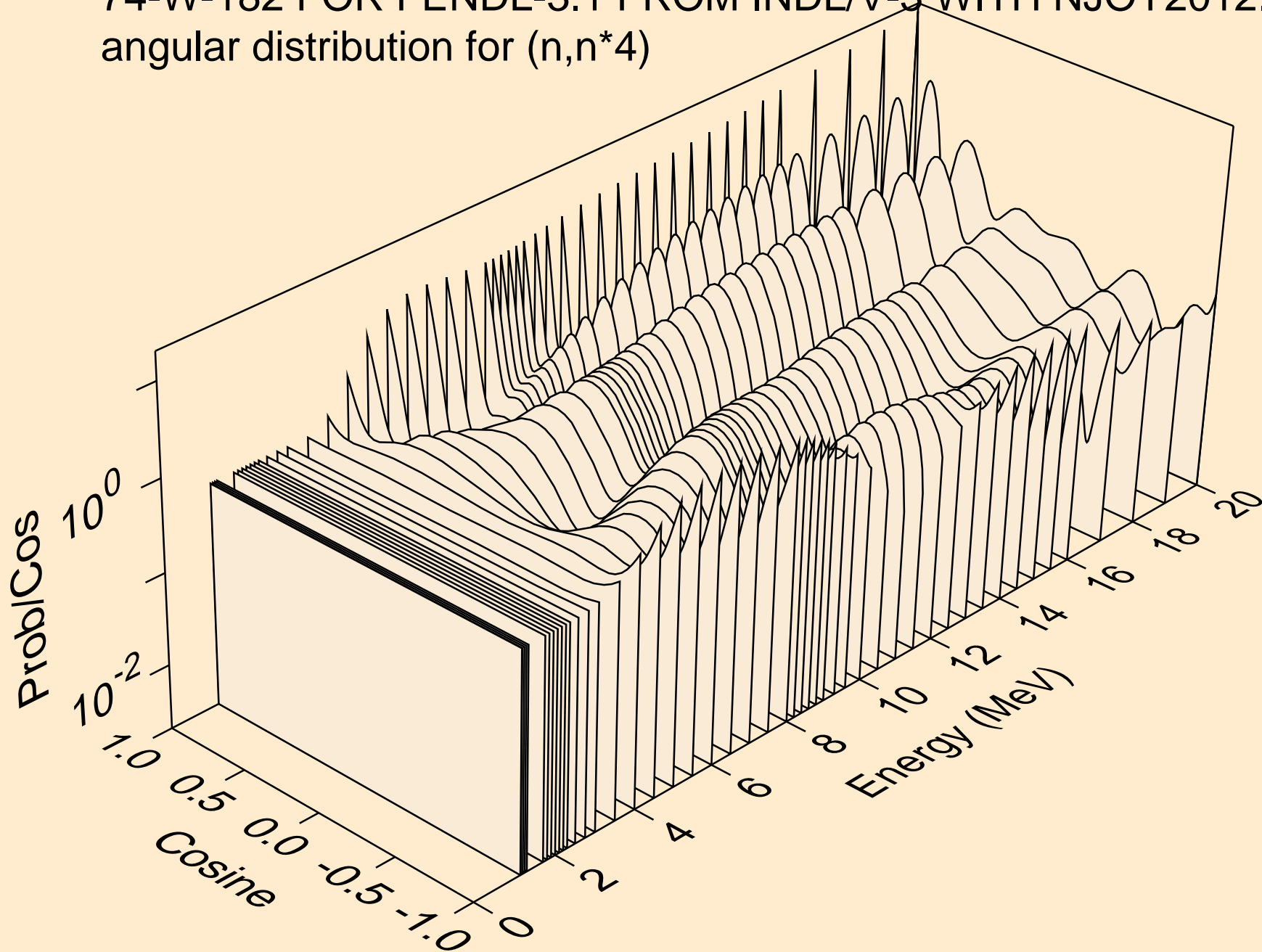

74-W-182 FOR FENDL-3.1 FROM INDL/V-3 WITH NJOY2012.50+ C
angular distribution for (n,n*4)

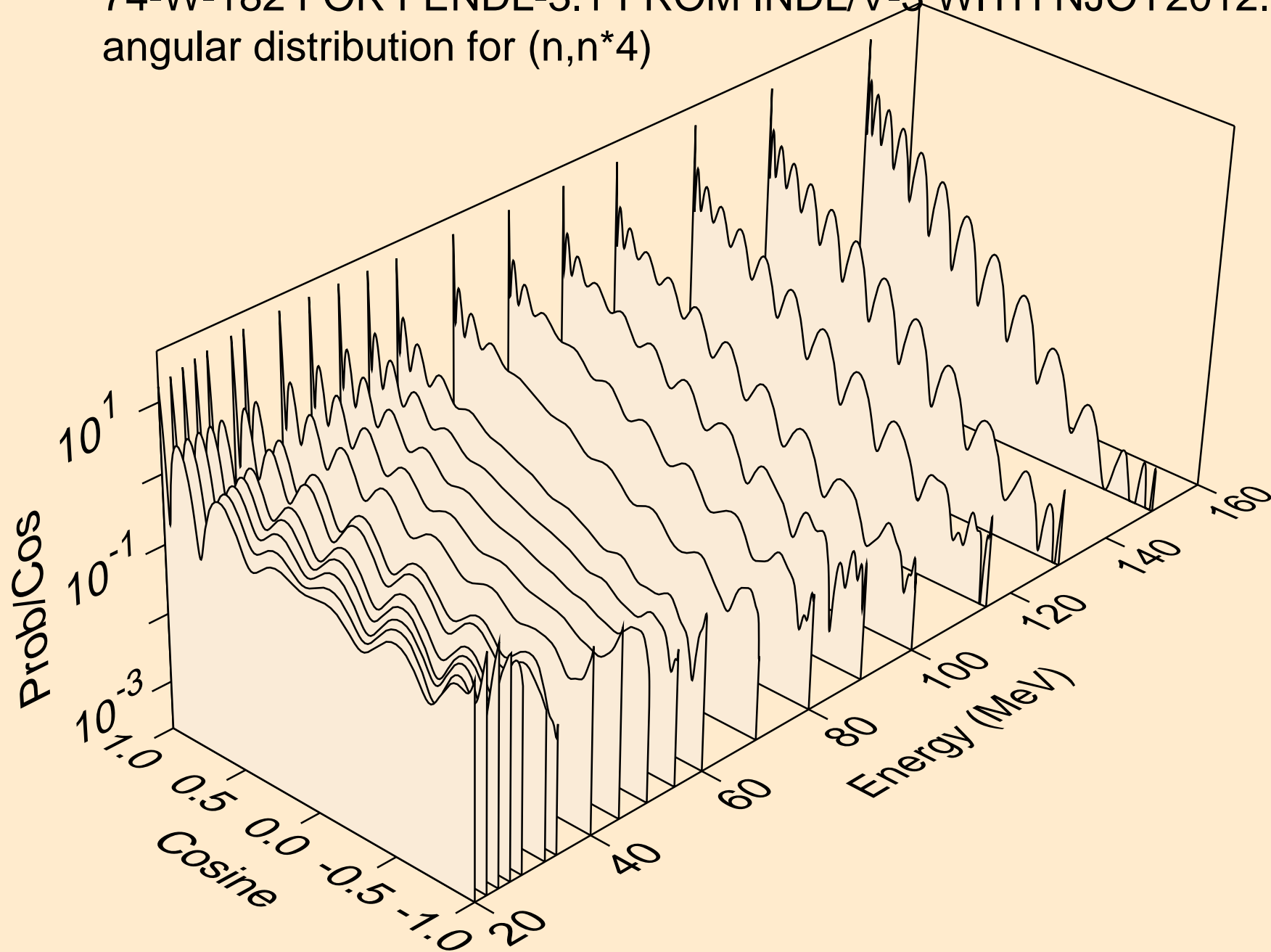

74-W-182 FOR FENDL-3.1 FROM INDL/V-3 WITH NJOY2012.50+ C
angular distribution for (n,n*5)

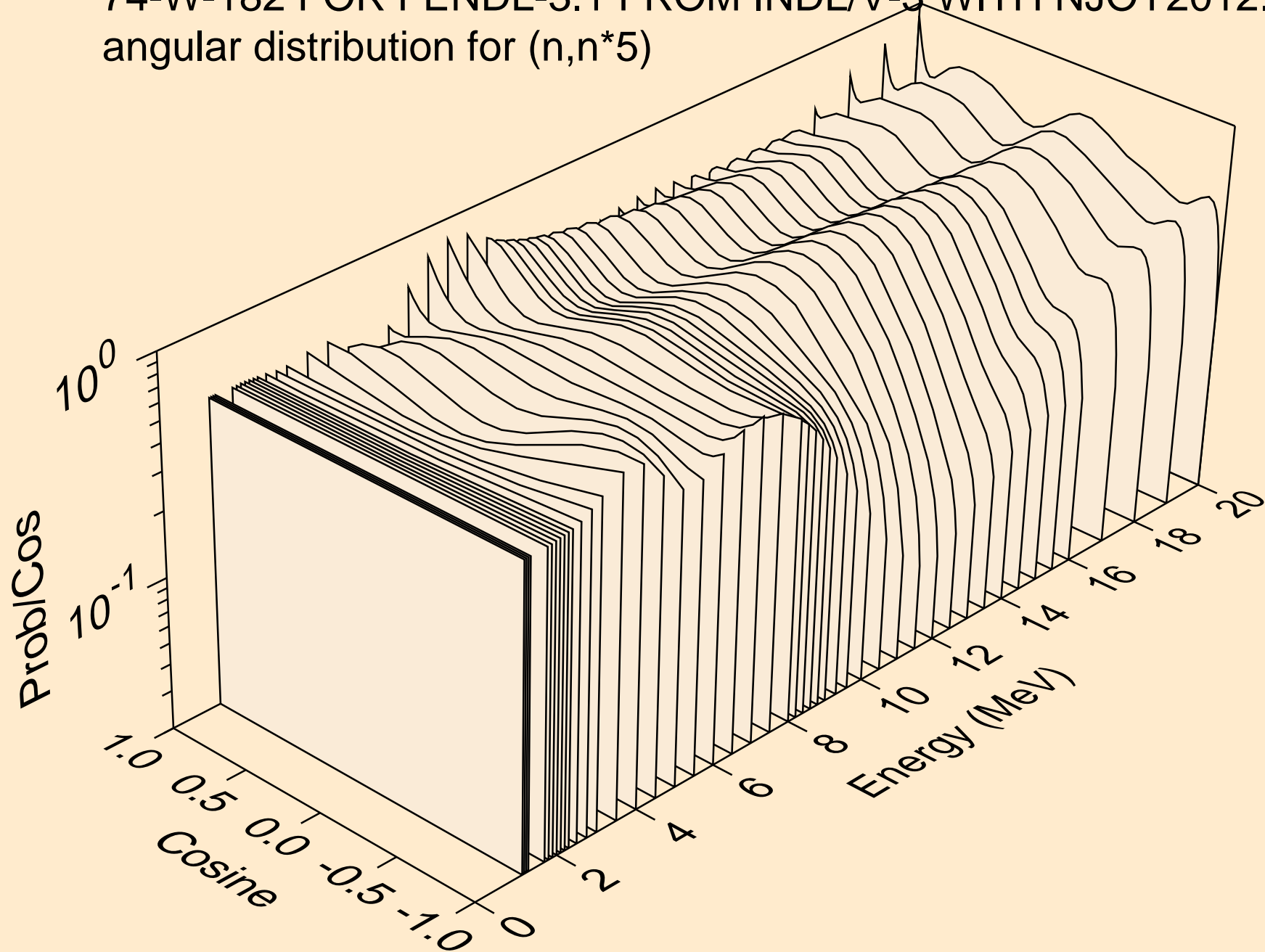

74-W-182 FOR FENDL-3.1 FROM INDL/V-3 WITH NJOY2012.50+ C
angular distribution for (n,n*5)

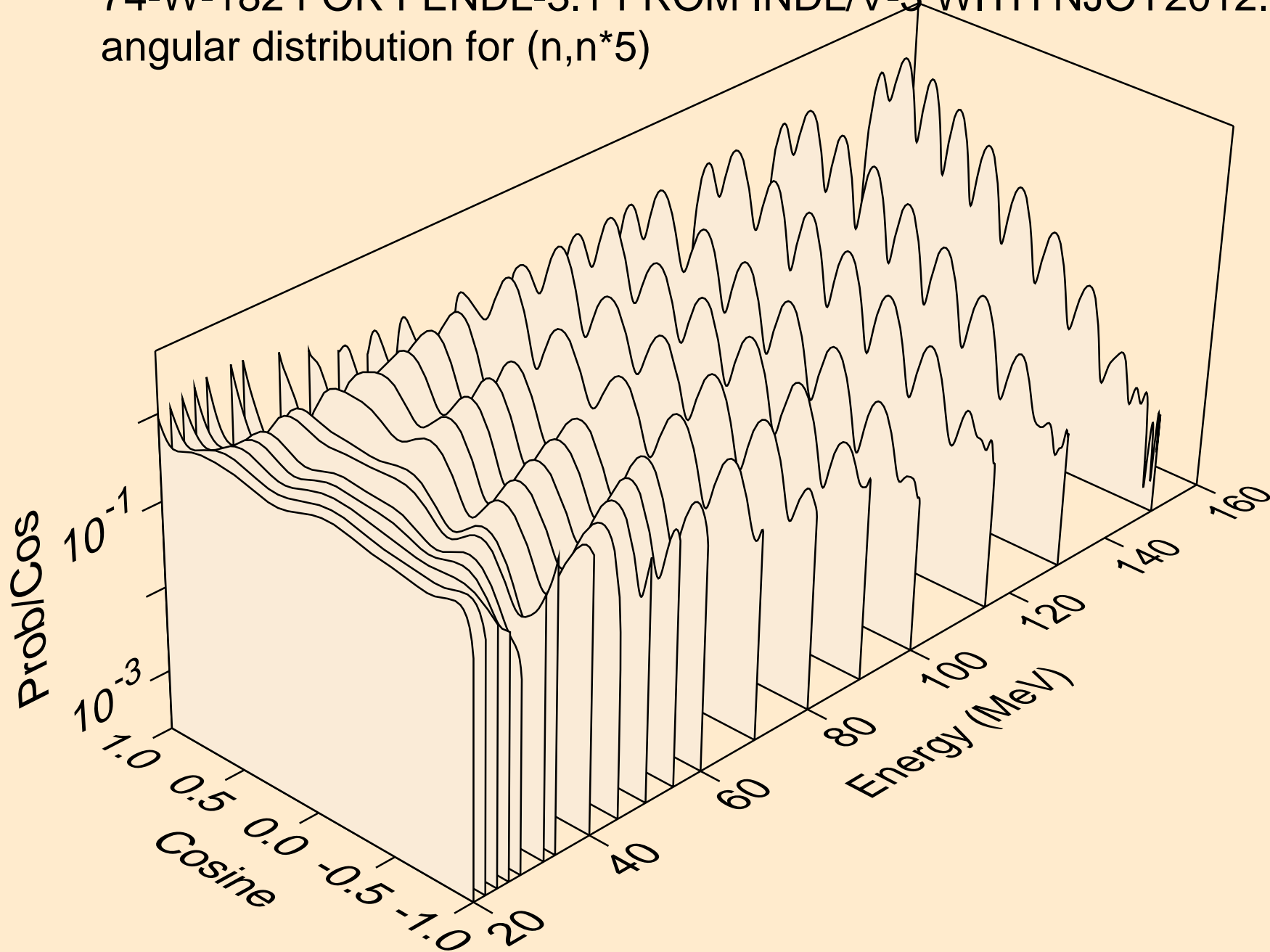

74-W-182 FOR FENDL-3.1 FROM INDL/V-3 WITH NJOY2012.50+ C
angular distribution for (n,n*6)

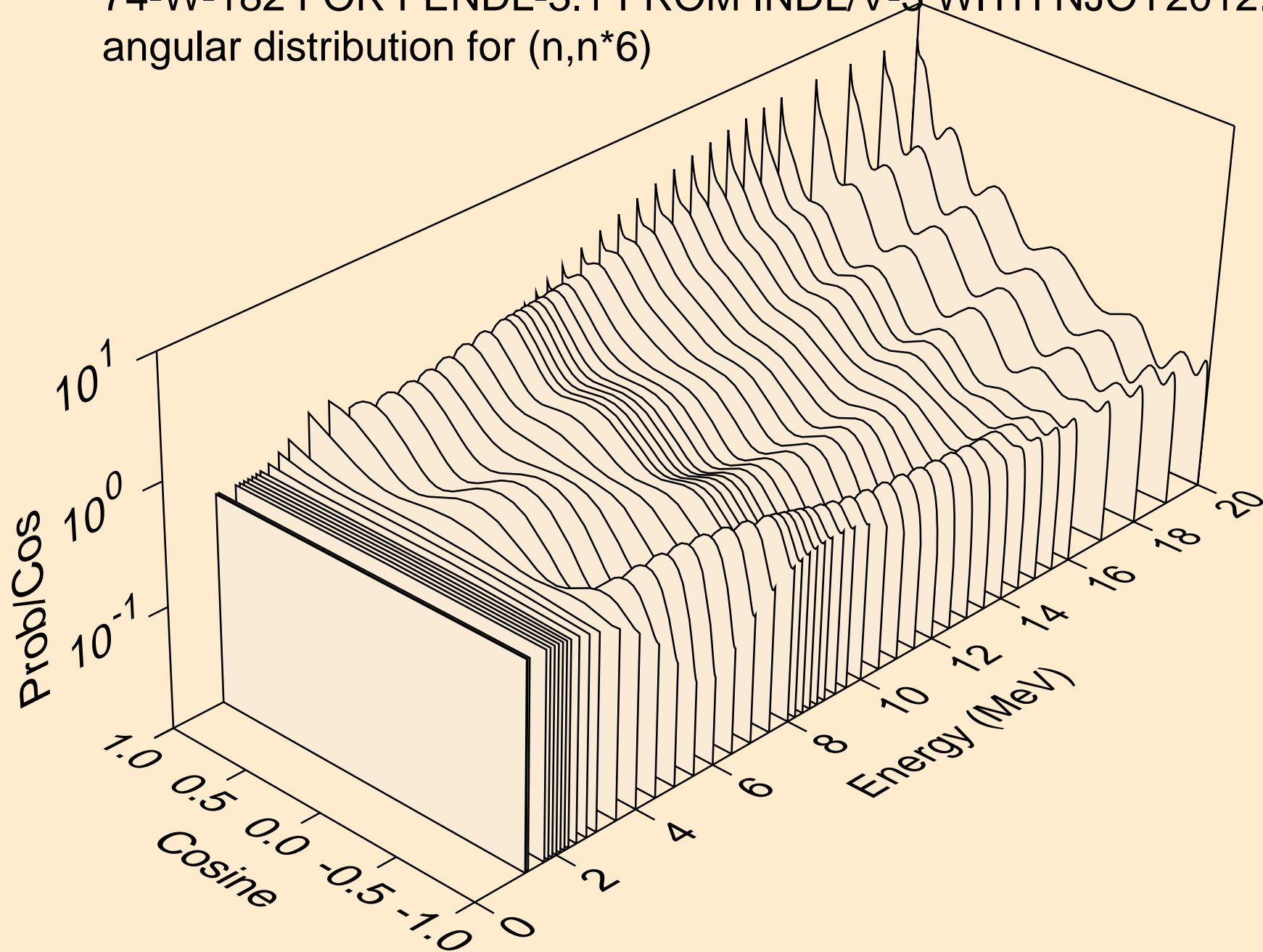

74-W-182 FOR FENDL-3.1 FROM INDL/V-3 WITH NJOY2012.50+ C
angular distribution for (n,n*6)

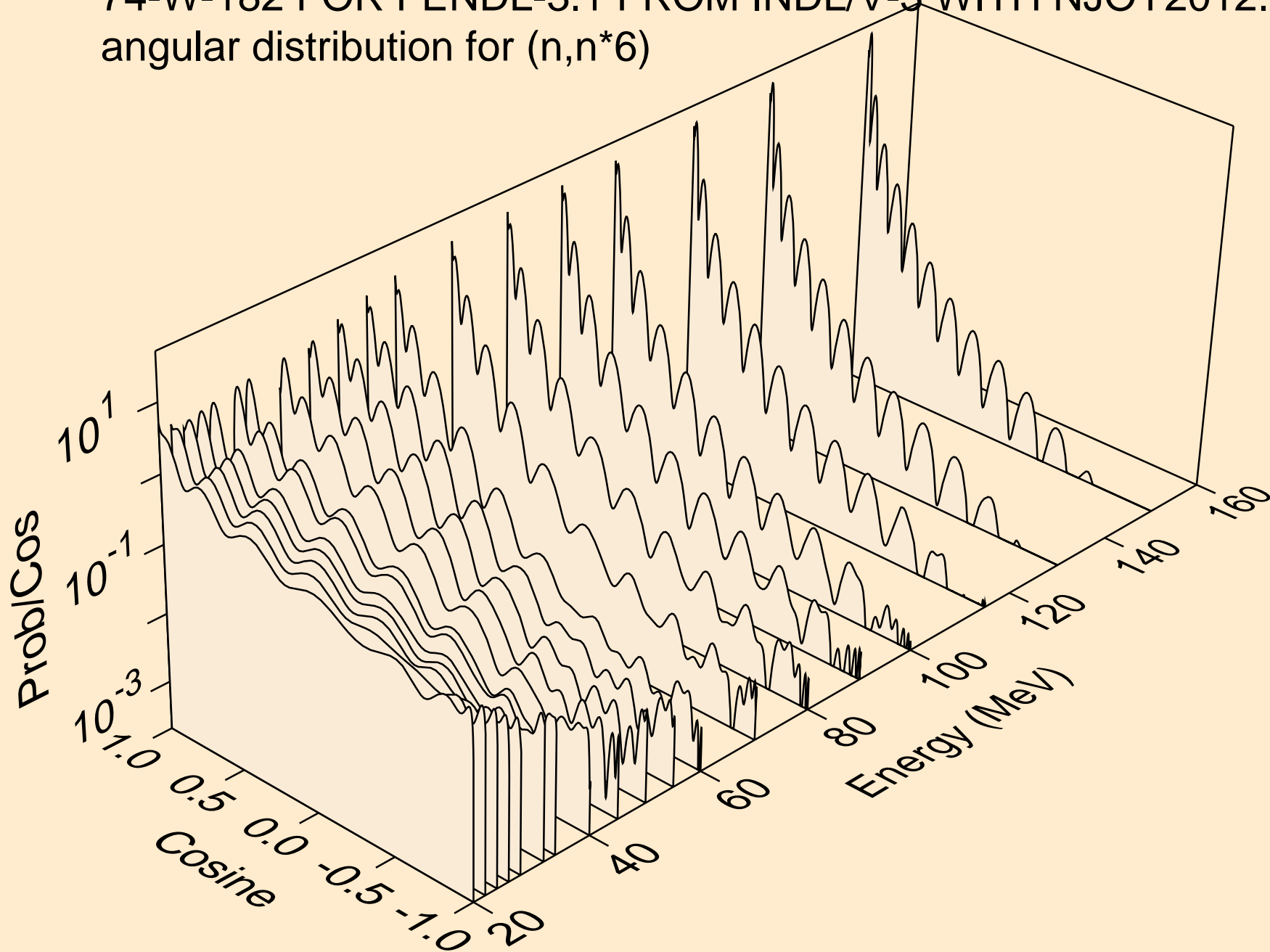

74-W-182 FOR FENDL-3.1 FROM INDL/V-3 WITH NJOY2012.50+ C
angular distribution for (n,n*7)

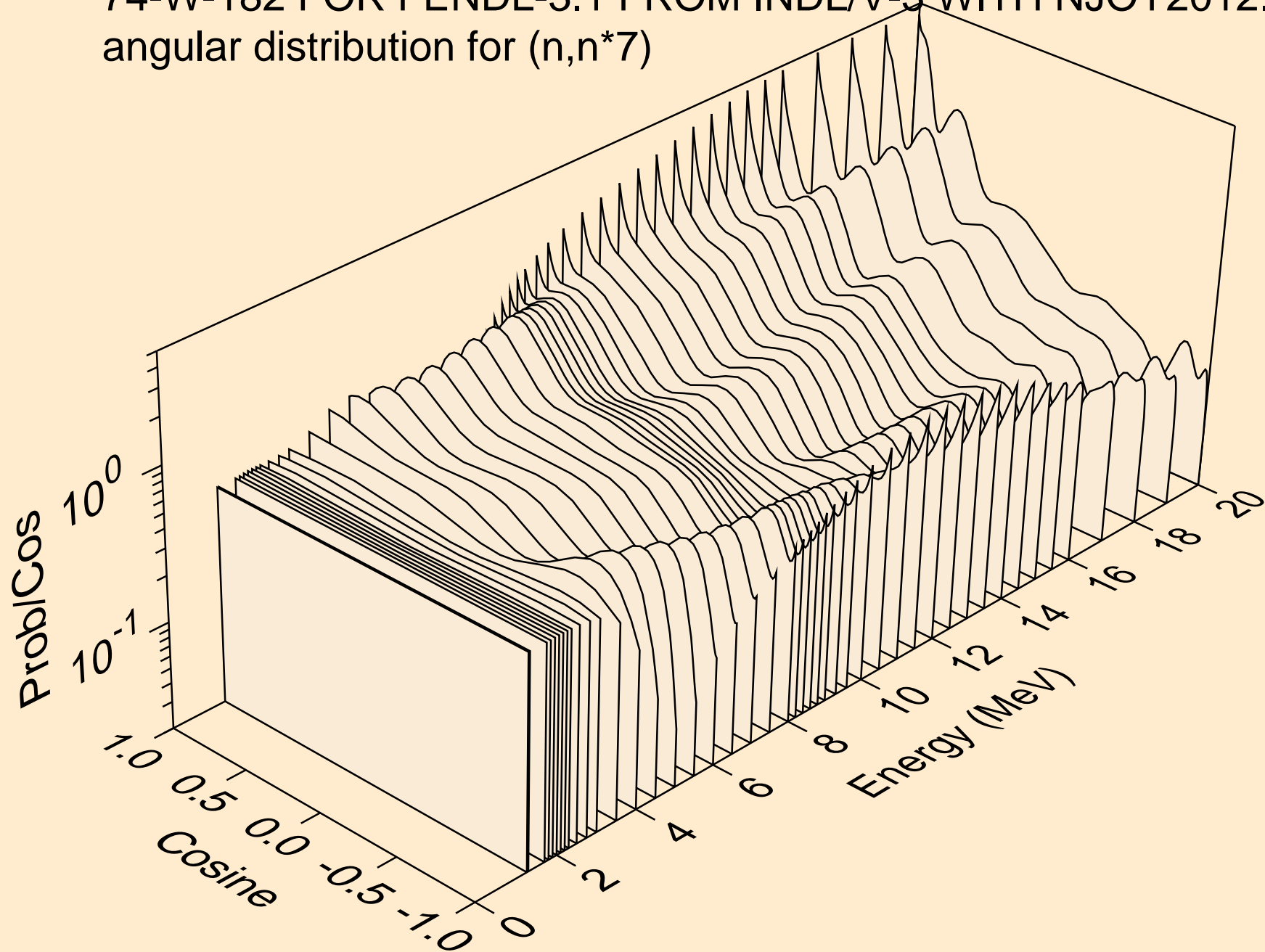

74-W-182 FOR FENDL-3.1 FROM INDL/V-3 WITH NJOY2012.50+ C
angular distribution for (n,n*7)

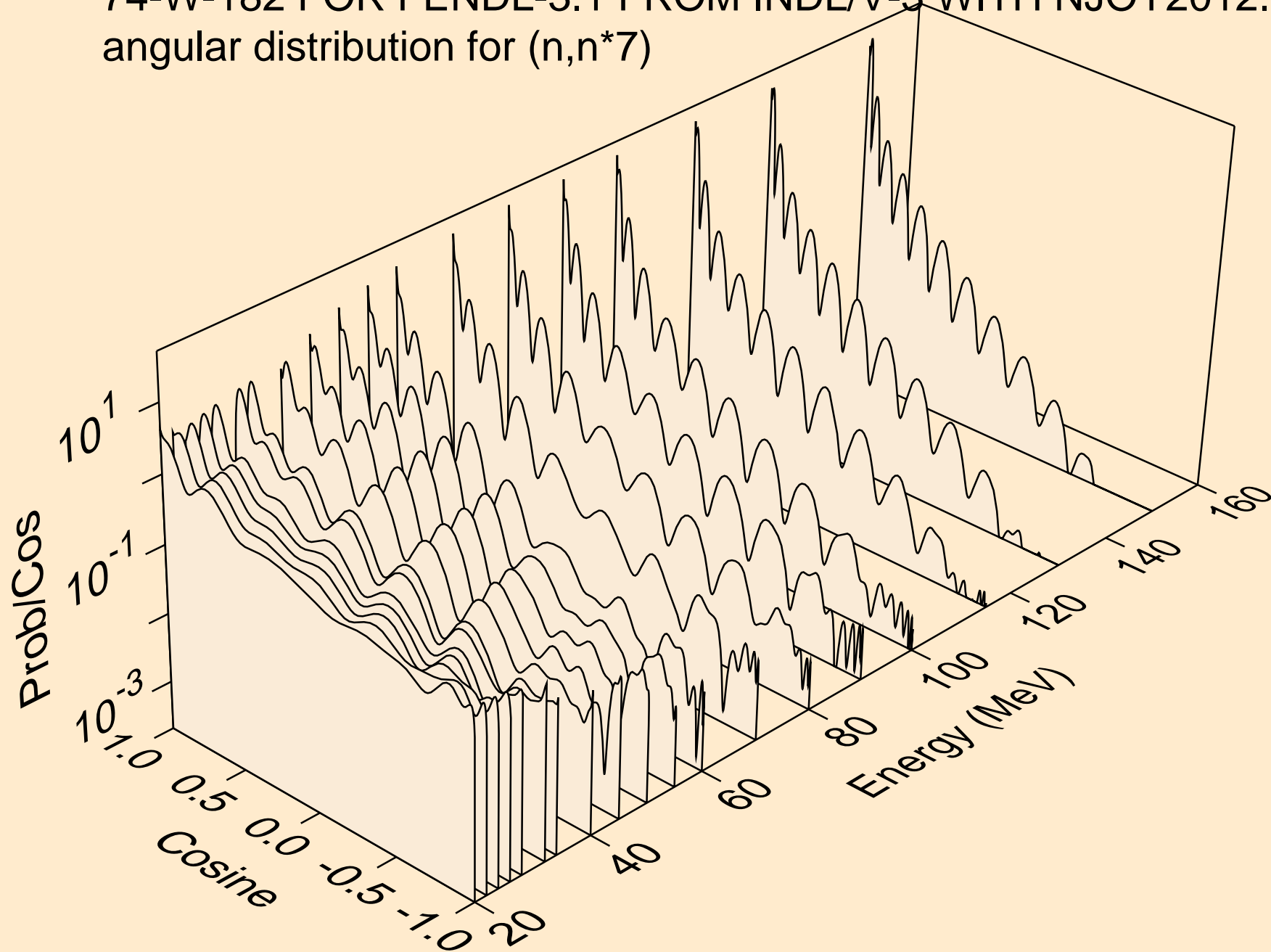

74-W-182 FOR FENDL-3.1 FROM INDL/V-3 WITH NJOY2012.50+ C
angular distribution for (n,n*8)

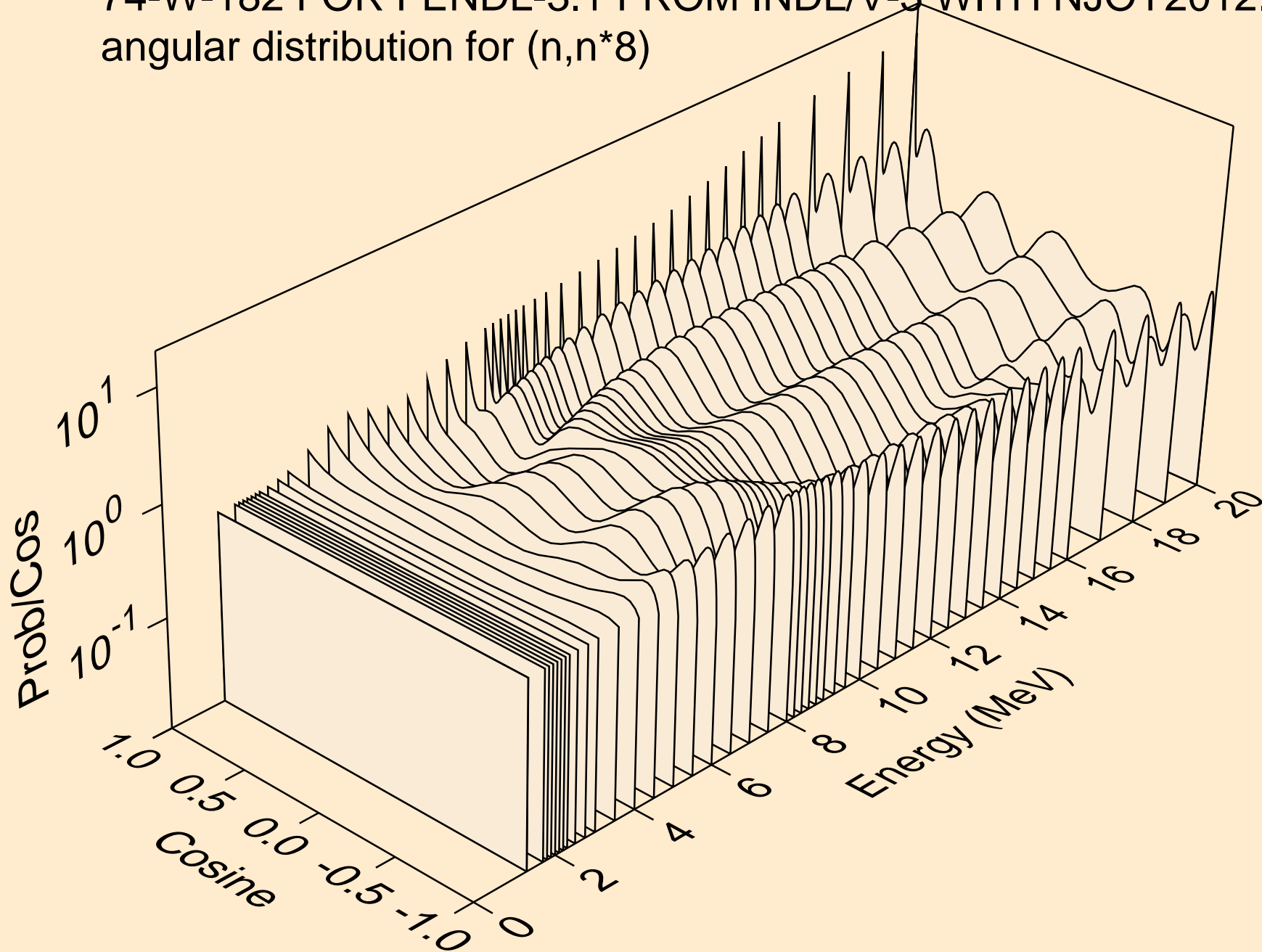

74-W-182 FOR FENDL-3.1 FROM INDL/V-3 WITH NJOY2012.50+ C
angular distribution for (n,n*8)

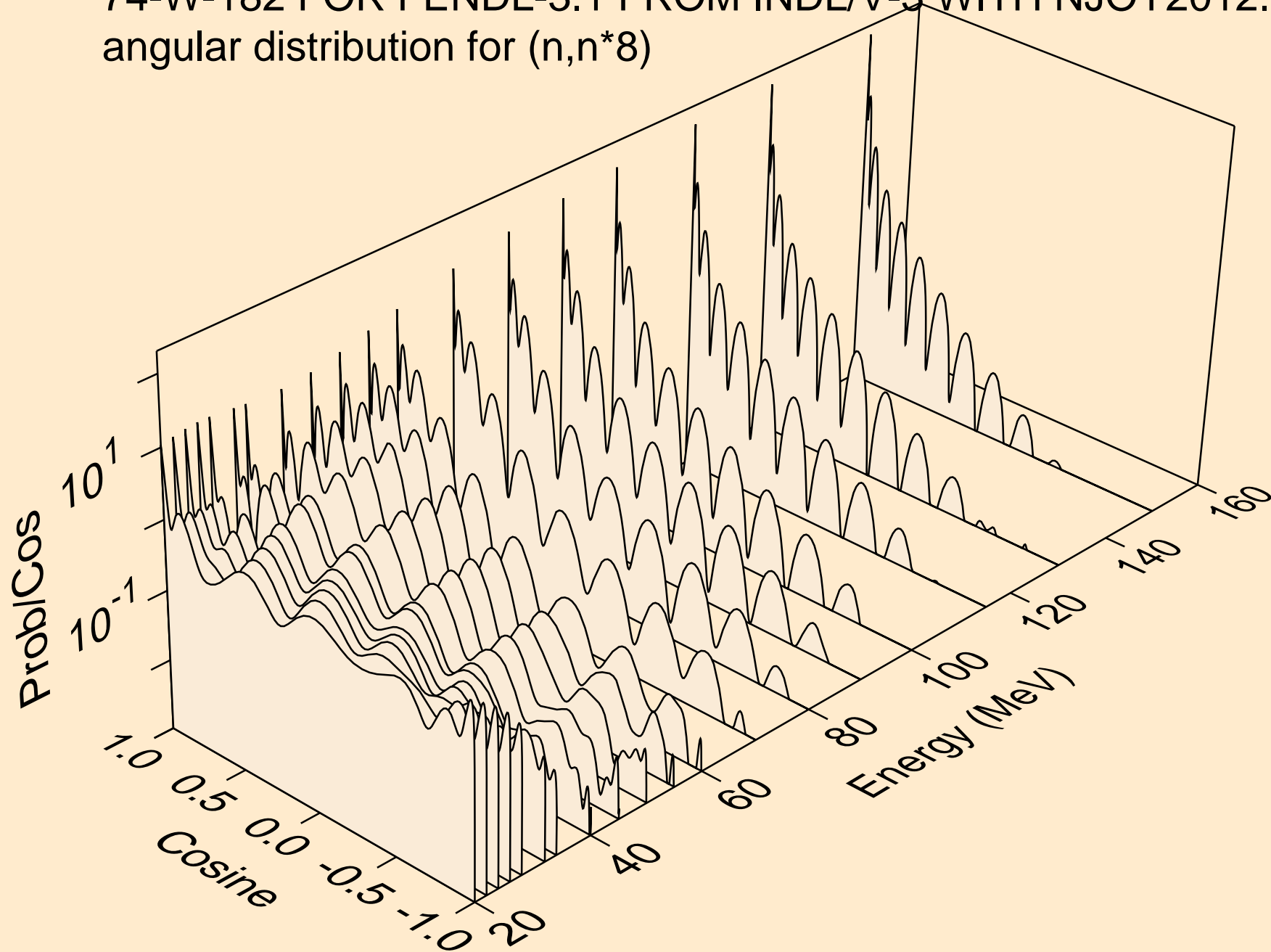

74-W-182 FOR FENDL-3.1 FROM INDL/V-3 WITH NJOY2012.50+ C
angular distribution for (n,n*9)

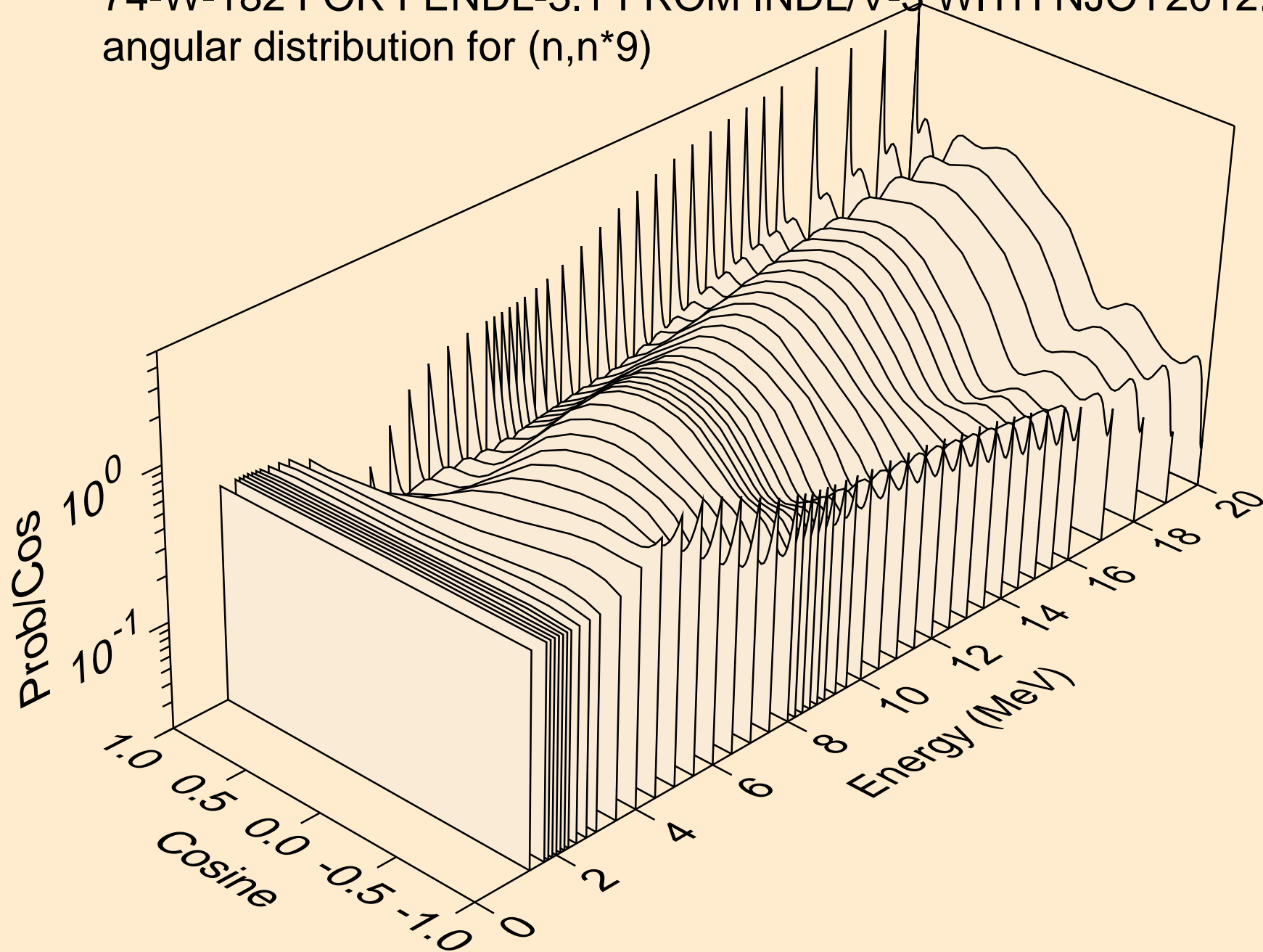

74-W-182 FOR FENDL-3.1 FROM INDL/V-3 WITH NJOY2012.50+ C
angular distribution for (n,n*9)

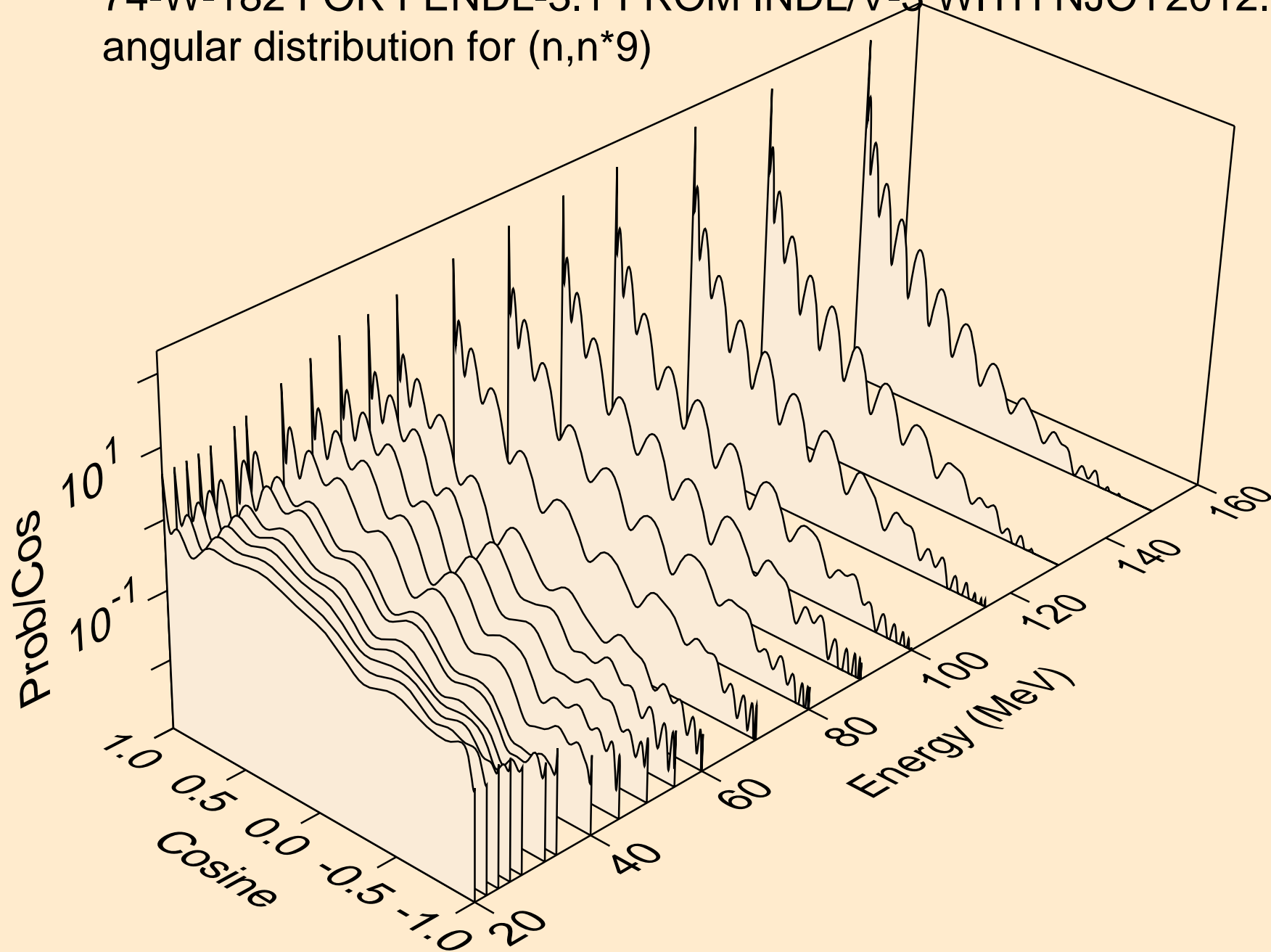

74-W-182 FOR FENDL-3.1 FROM INDLV-3 WITH NJOY2012.50+ C
Neutron emission for (n,x)

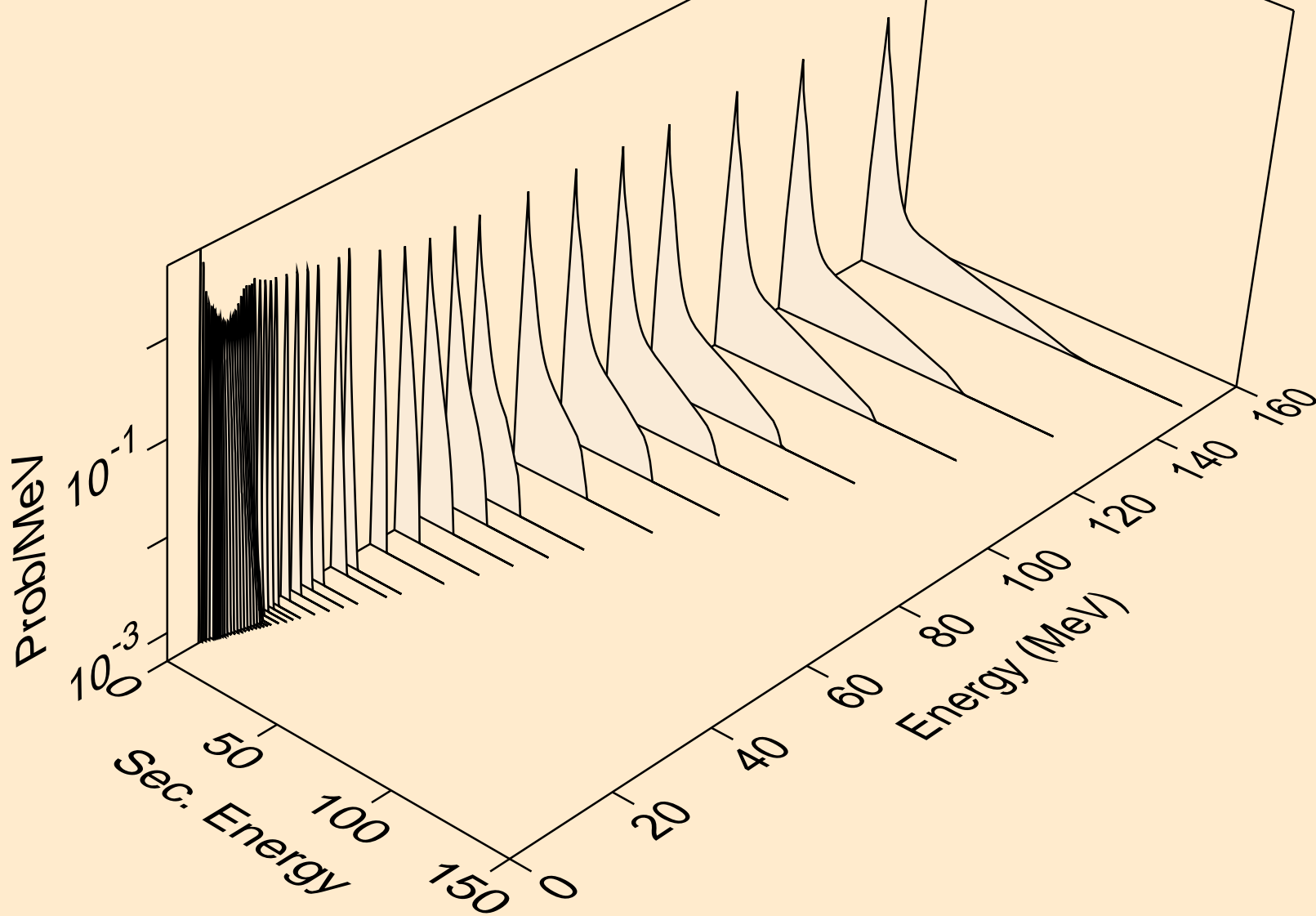

74-W-182 FOR FENDL-3.1 FROM INDLV-3 WITH NJOY2012.50+ C
Neutron emission for (n,2n)

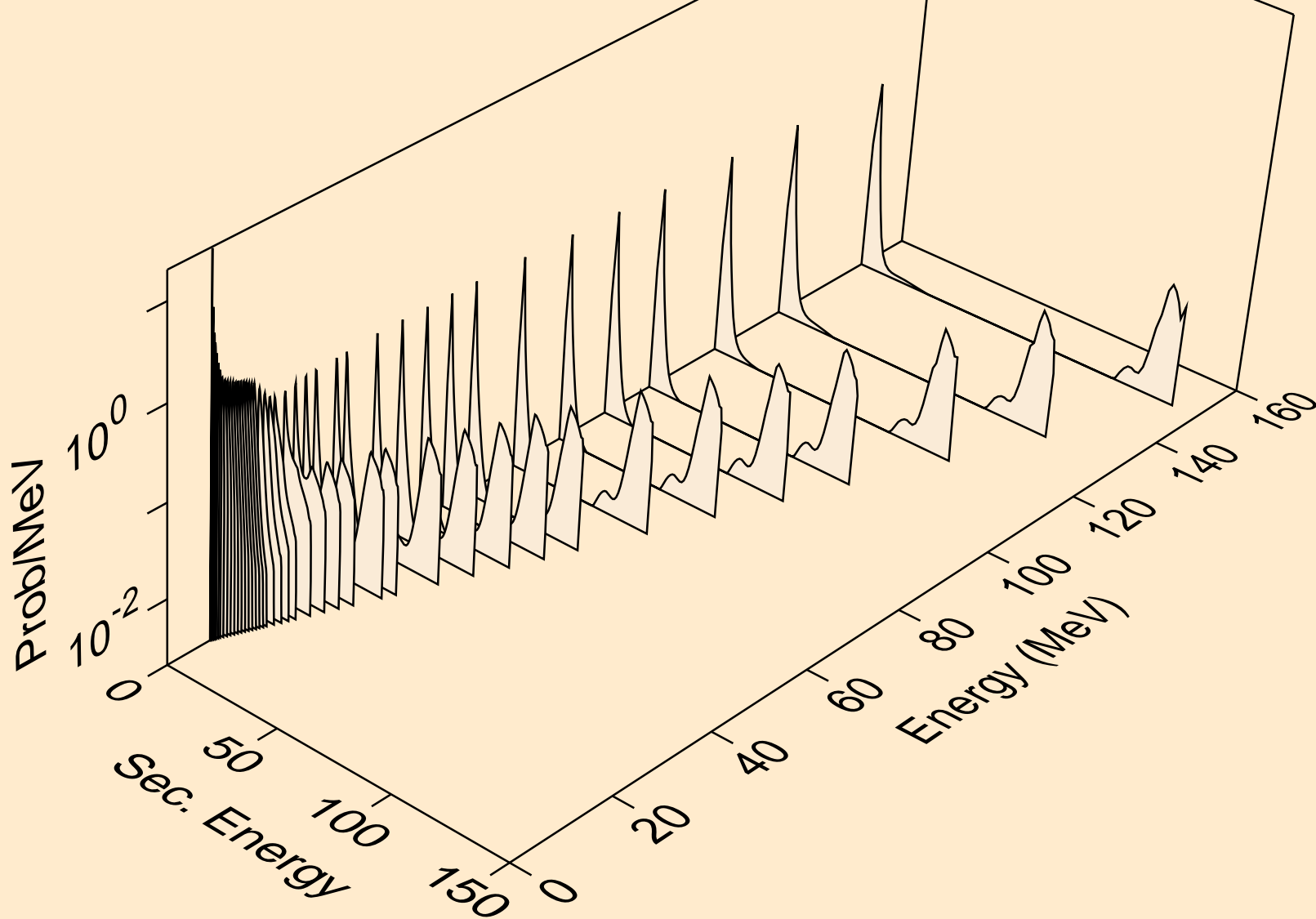

74-W-182 FOR FENDL-3.1 FROM INDLV-3 WITH NJOY2012.50+ C
Neutron emission for (n,3n)

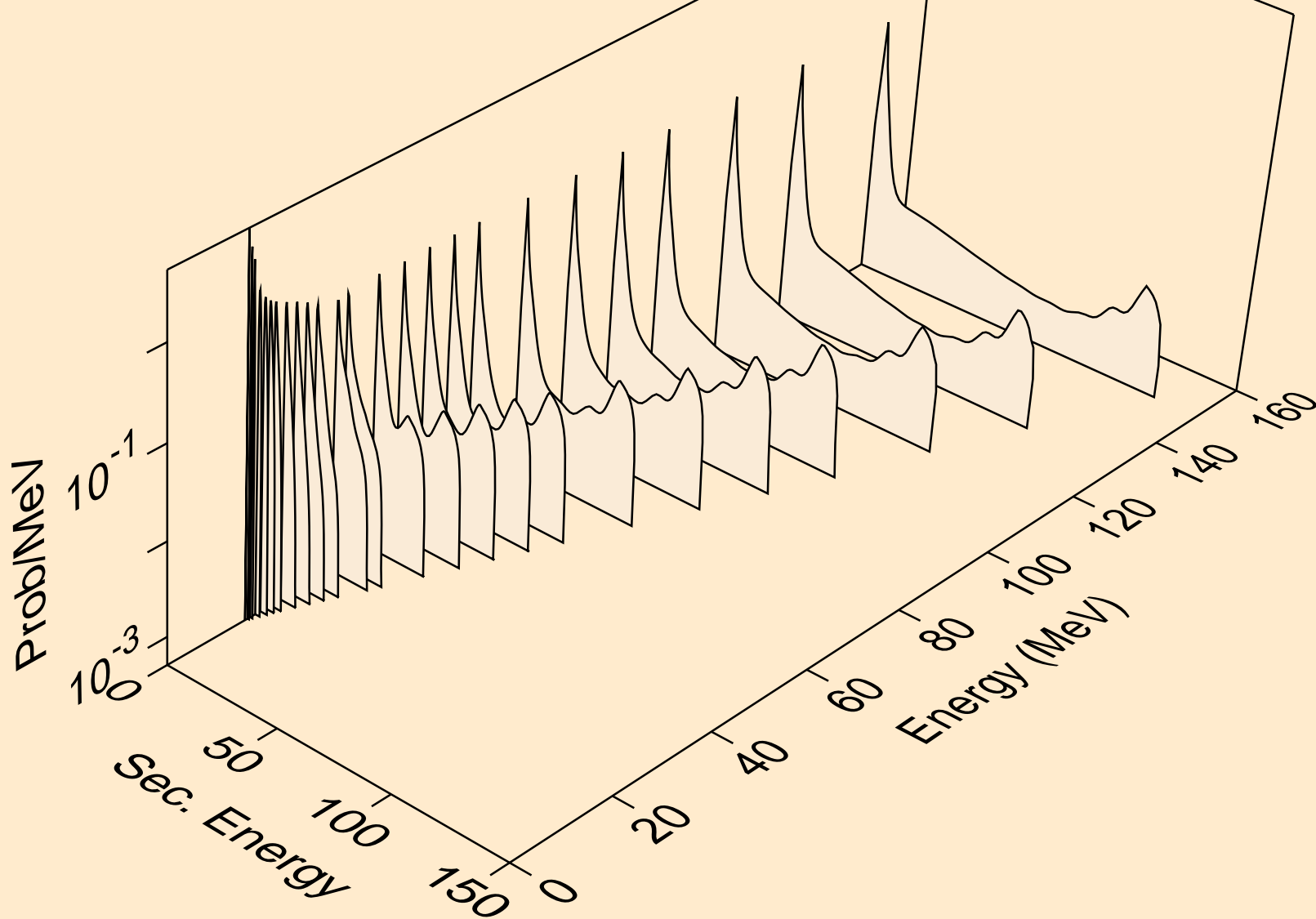

74-W-182 FOR FENDL-3.1 FROM INDLV-3 WITH NJOY2012.50+ C
Neutron emission for (n,n*)p

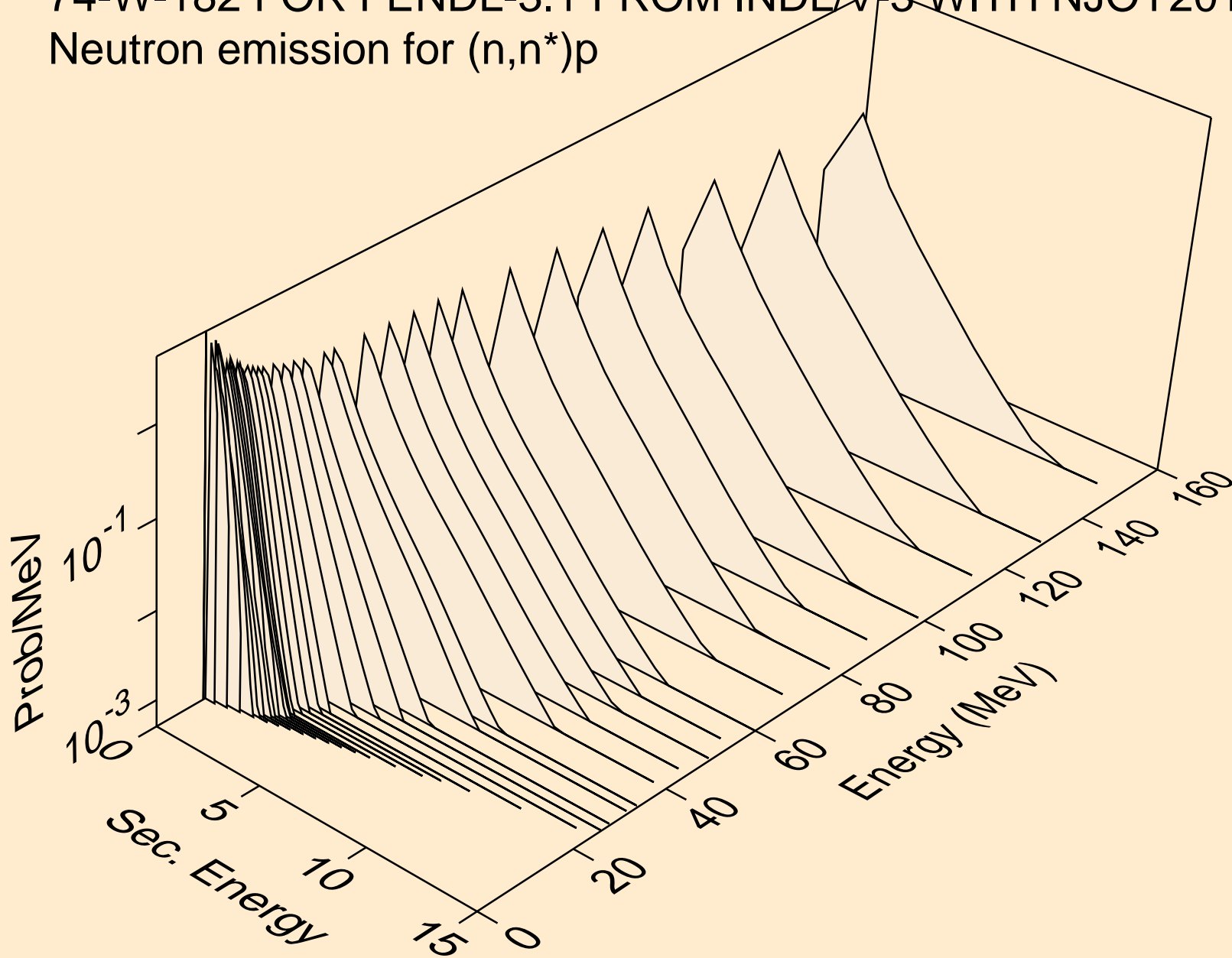

74-W-182 FOR FENDL-3.1 FROM INDLV-3 WITH NJOY2012.50+ C
Neutron emission for (n,4n)

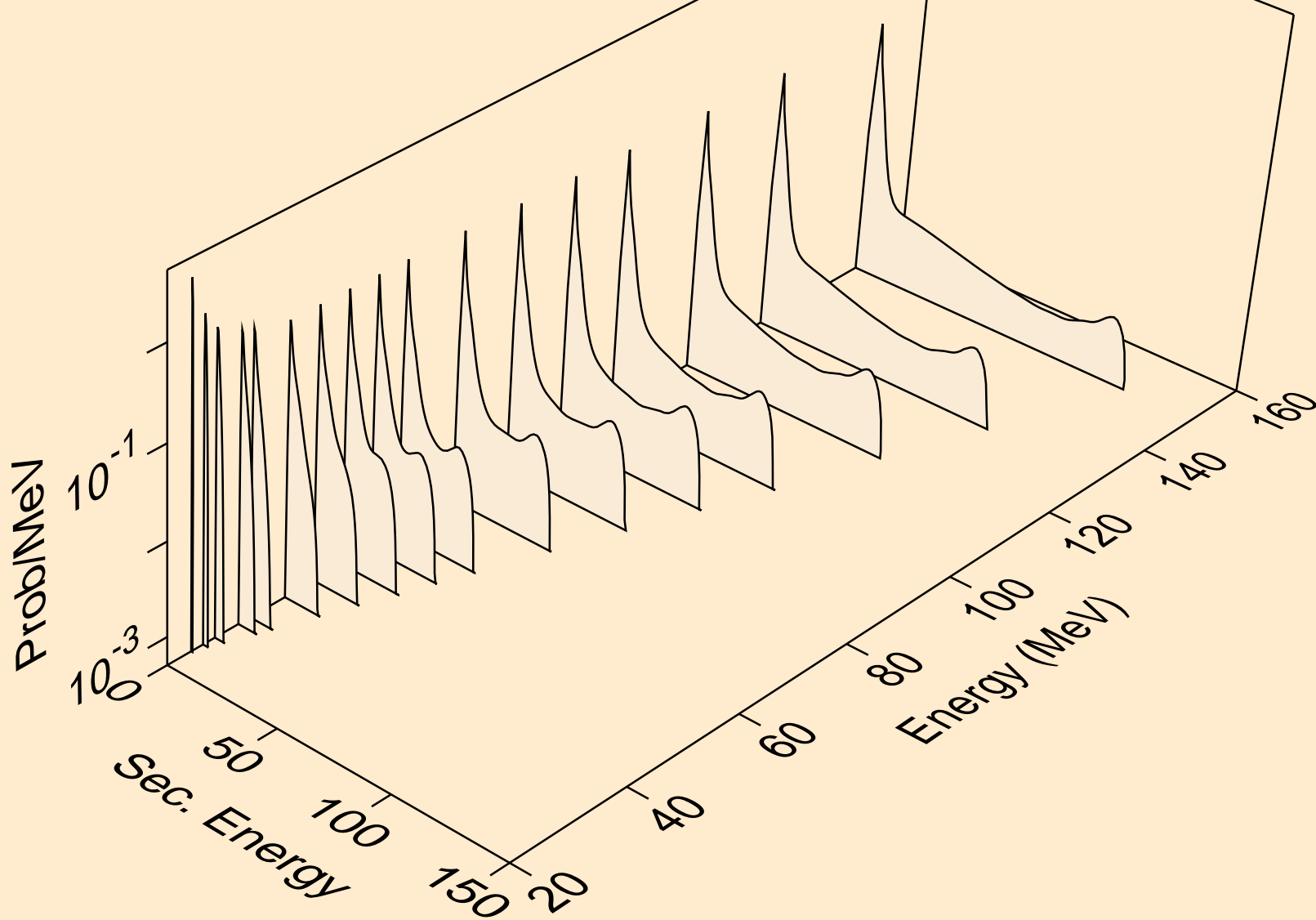

74-W-182 FOR FENDL-3.1 FROM INDLV-3 WITH NJOY2012.50+ C
Neutron emission for (n,2np)

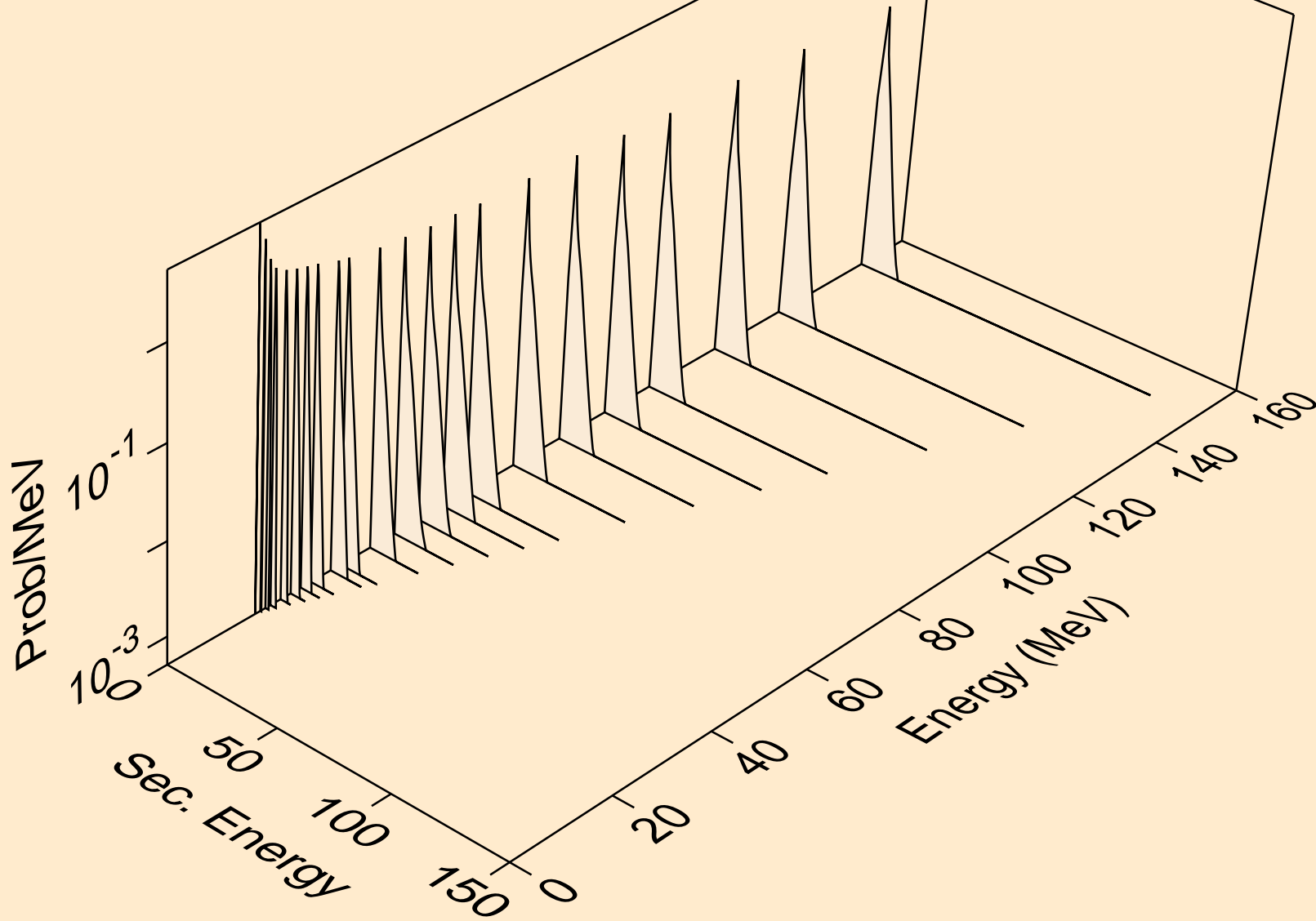

74-W-182 FOR FENDL-3.1 FROM INDLV-3 WITH NJOY2012.50+ C
Neutron emission for (n,n*c)

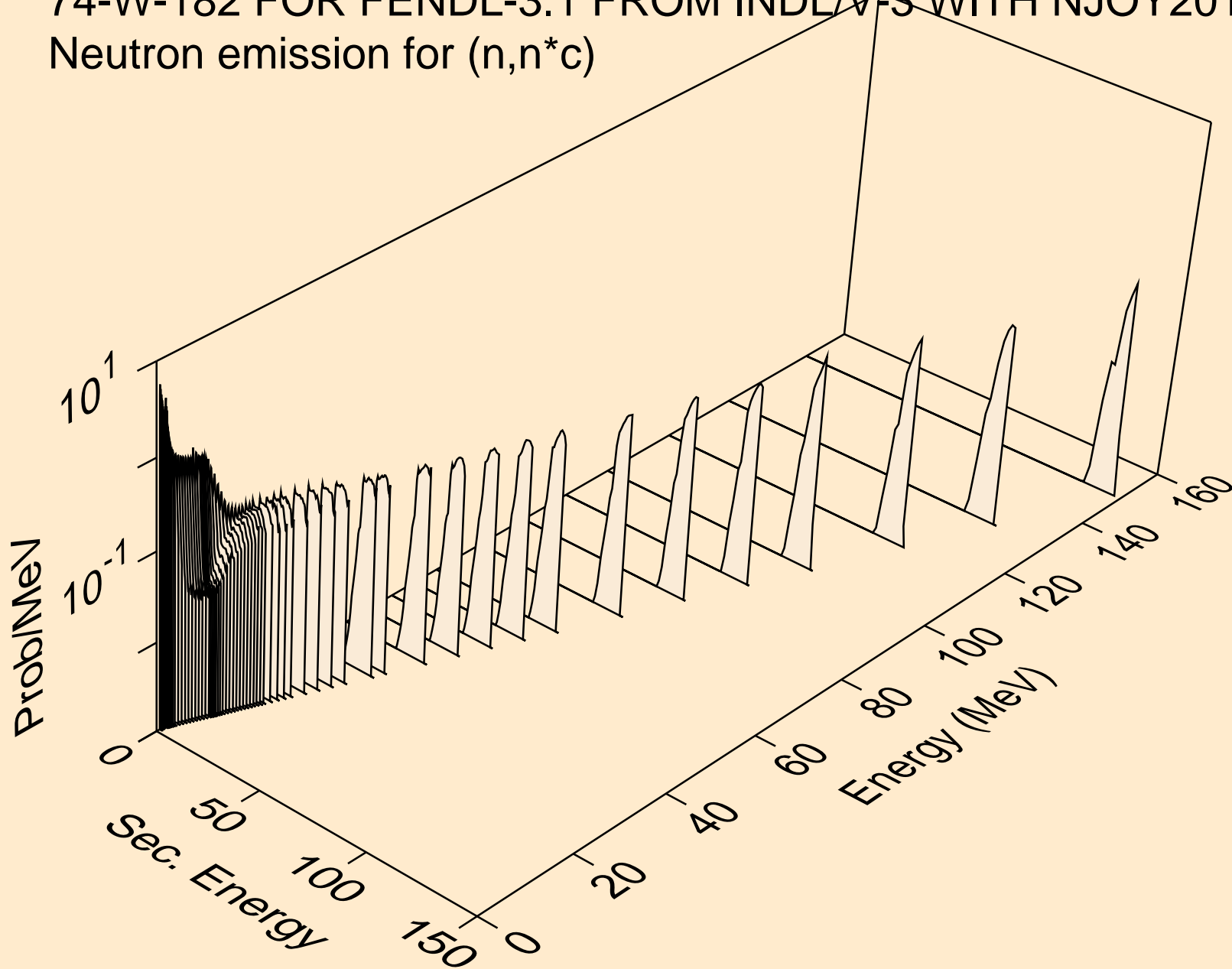

74-W-182 FOR FENDL-3.1 FROM INDLV-3 WITH NJOY2012.50+ C
Photon emission for (n,x)

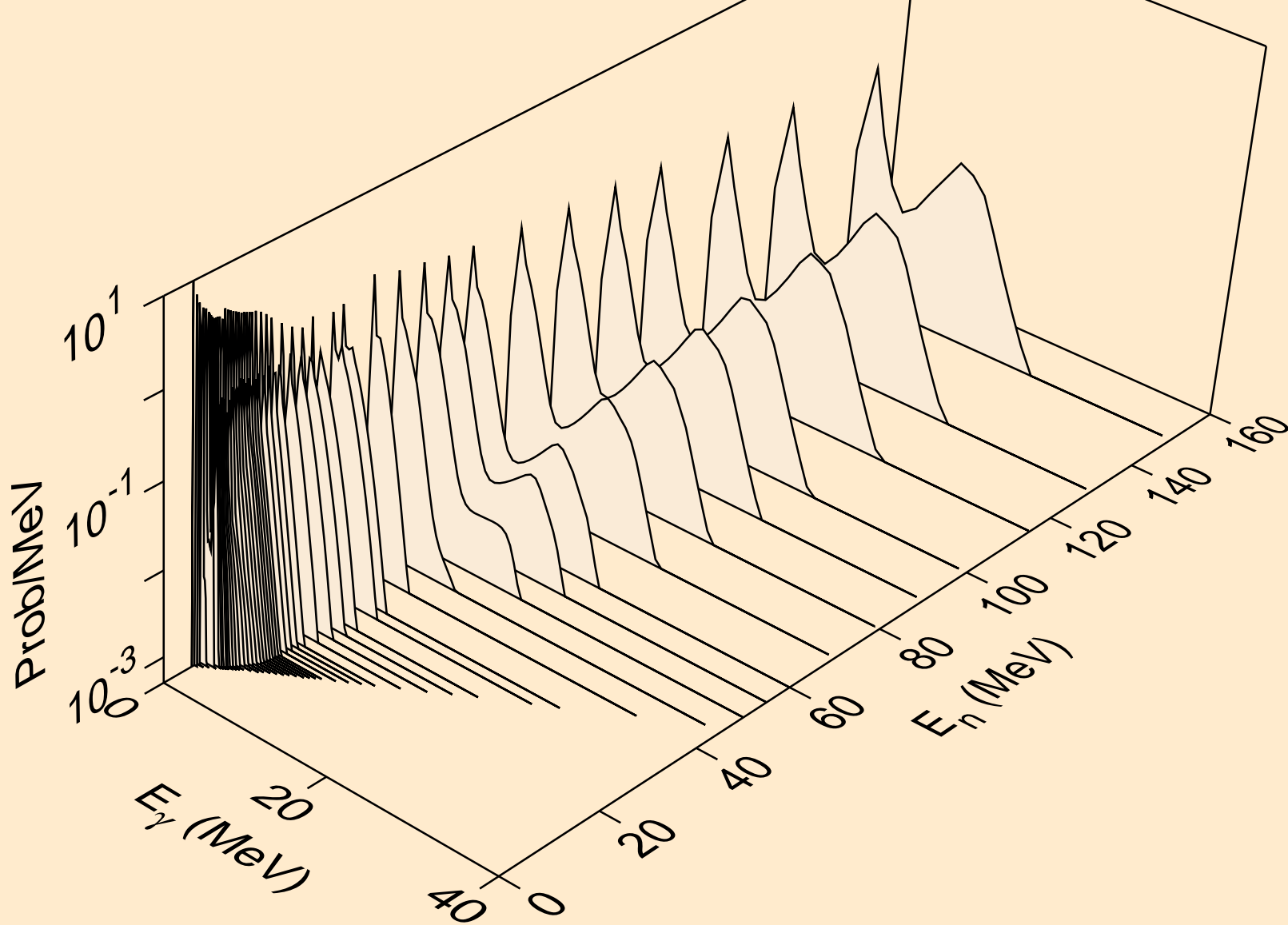

74-W-182 FOR FENDL-3.1 FROM INDLV-3 WITH NJOY2012.50+ C
Photon emission for (n,2n)

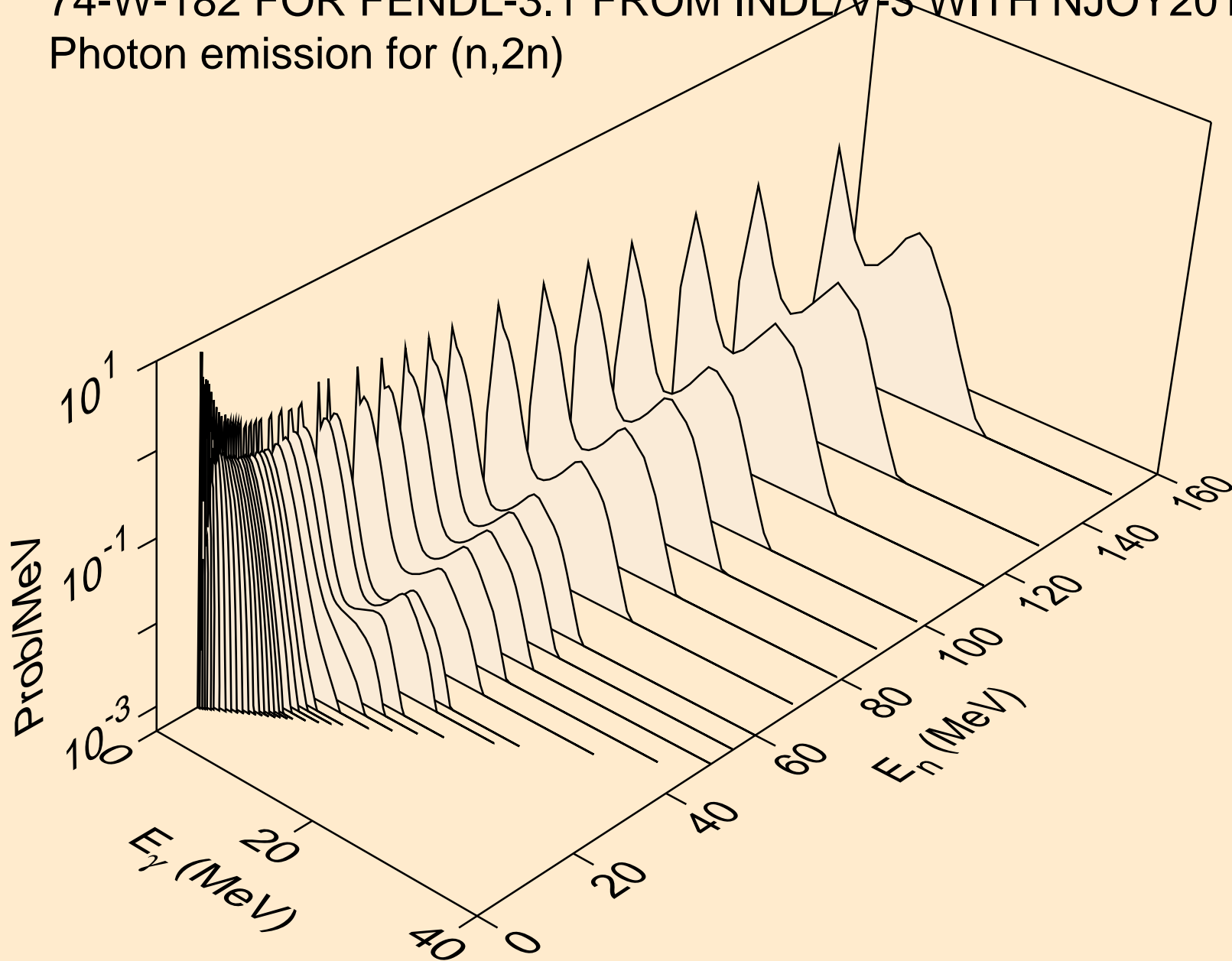

74-W-182 FOR FENDL-3.1 FROM INDLV-3 WITH NJOY2012.50+ C
Photon emission for (n,3n)

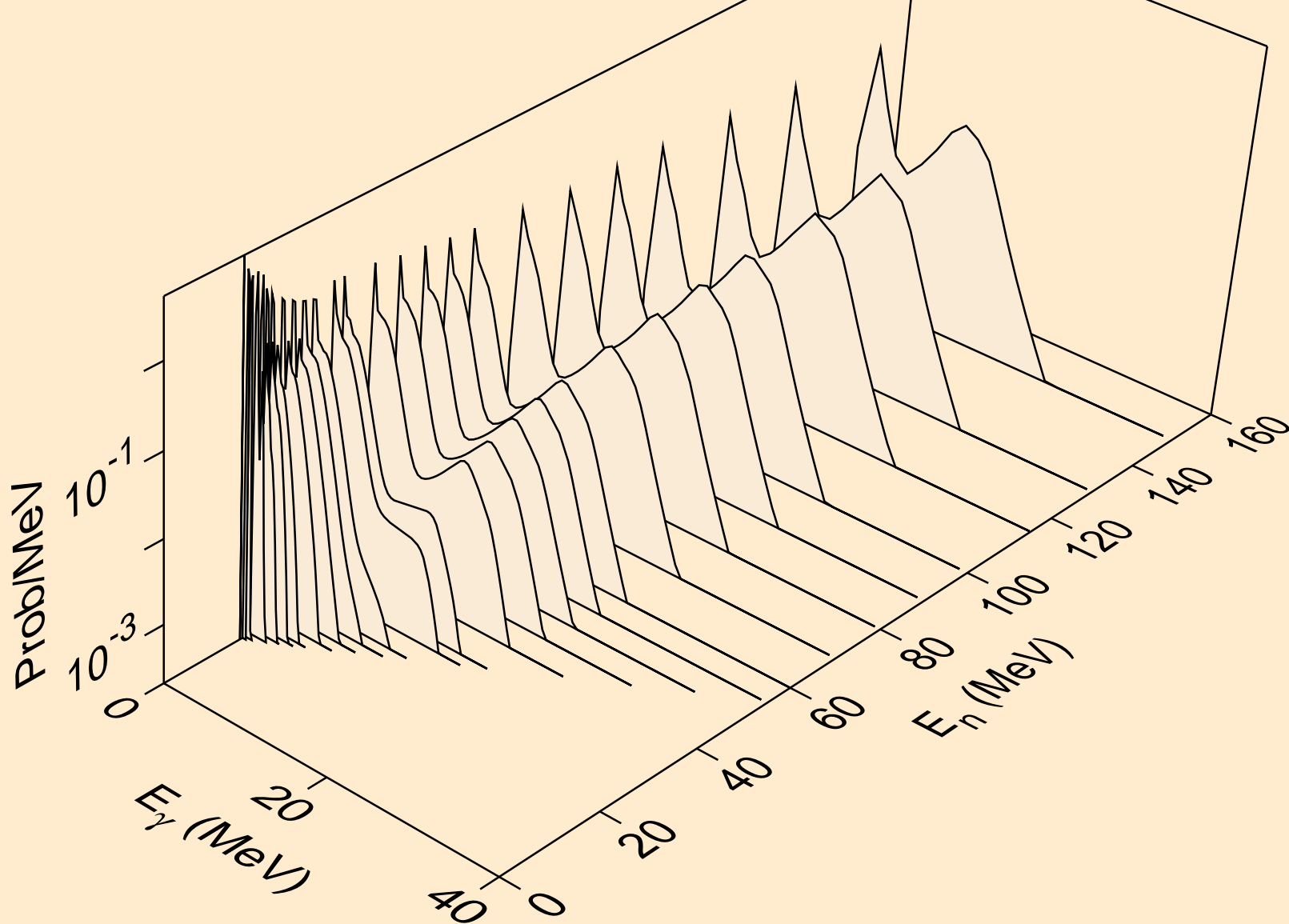

74-W-182 FOR FENDL-3.1 FROM INDLV-3 WITH NJOY2012.50+ C
Photon emission for (n,n*)p

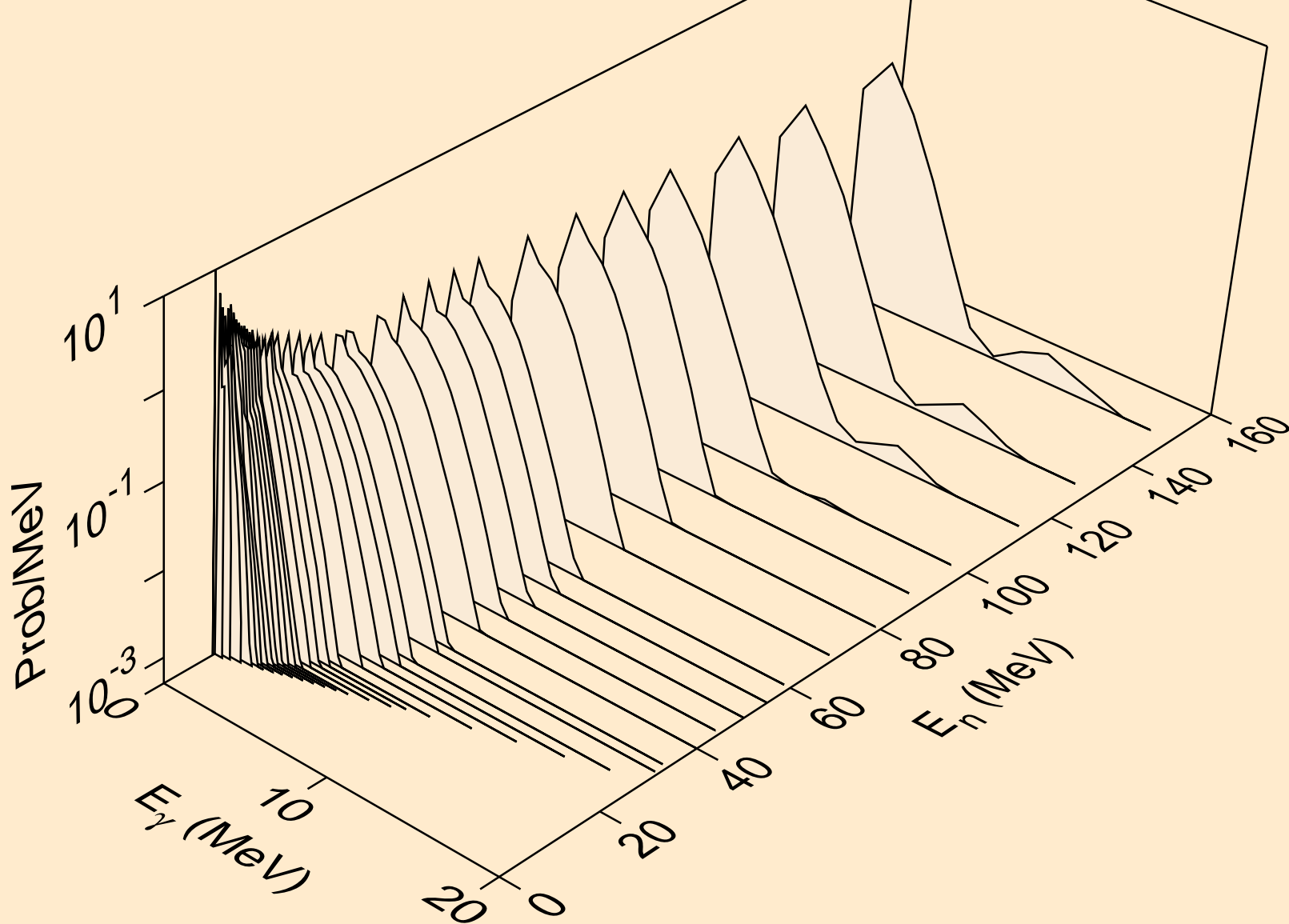

74-W-182 FOR FENDL-3.1 FROM INDLV-3 WITH NJOY2012.50+ C
Photon emission for (n,4n)

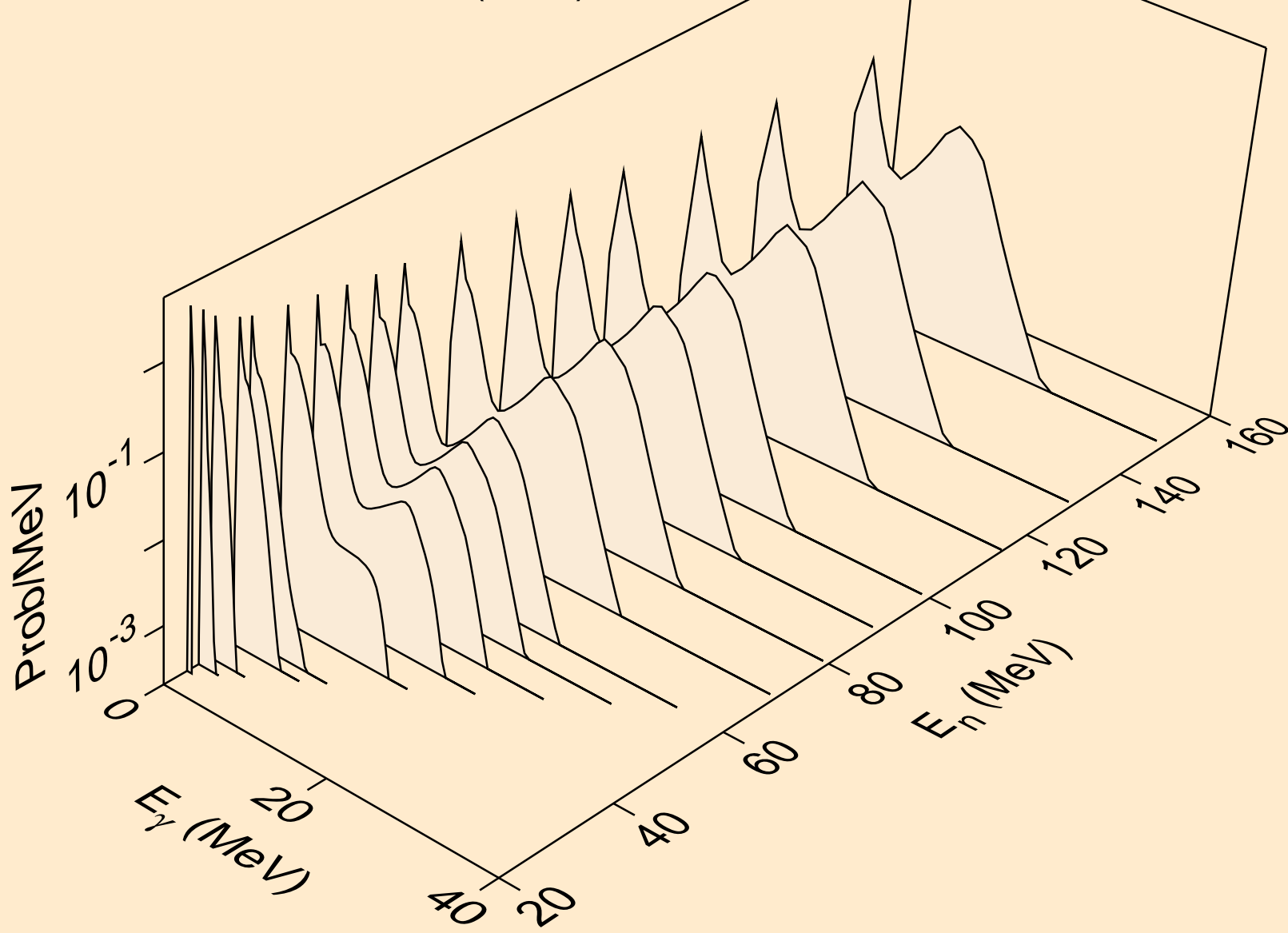

74-W-182 FOR FENDL-3.1 FROM INDLV-3 WITH NJOY2012.50+ C
Photon emission for (n,2np)

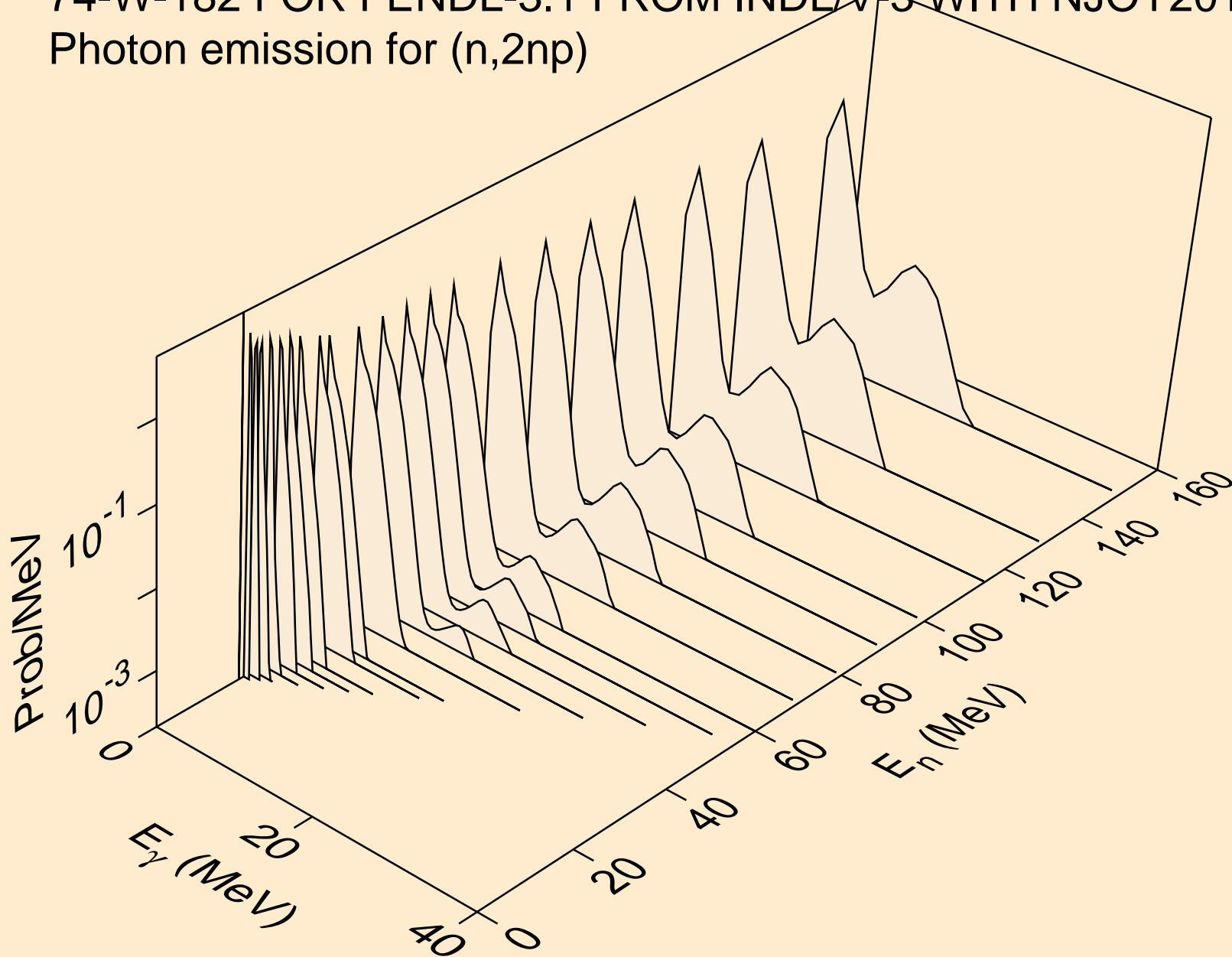

74-W-182 FOR FENDL-3.1 FROM INDLV-3 WITH NJOY2012.50+ C
Photon emission for (n,n*c)

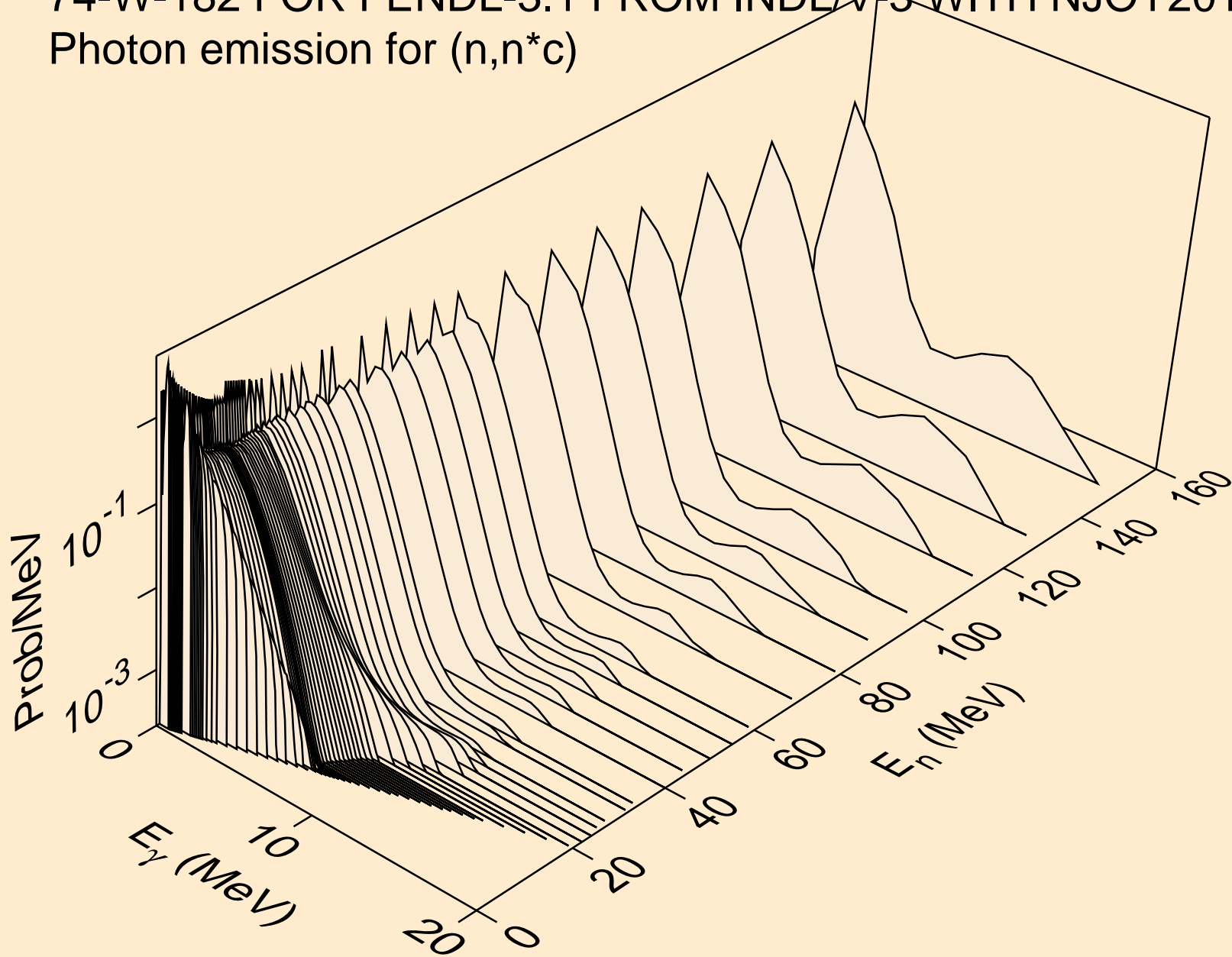

74-W-182 FOR FENDL-3.1 FROM INDLV-3 WITH NJOY2012.50+ C
Photon emission for (n,gma)

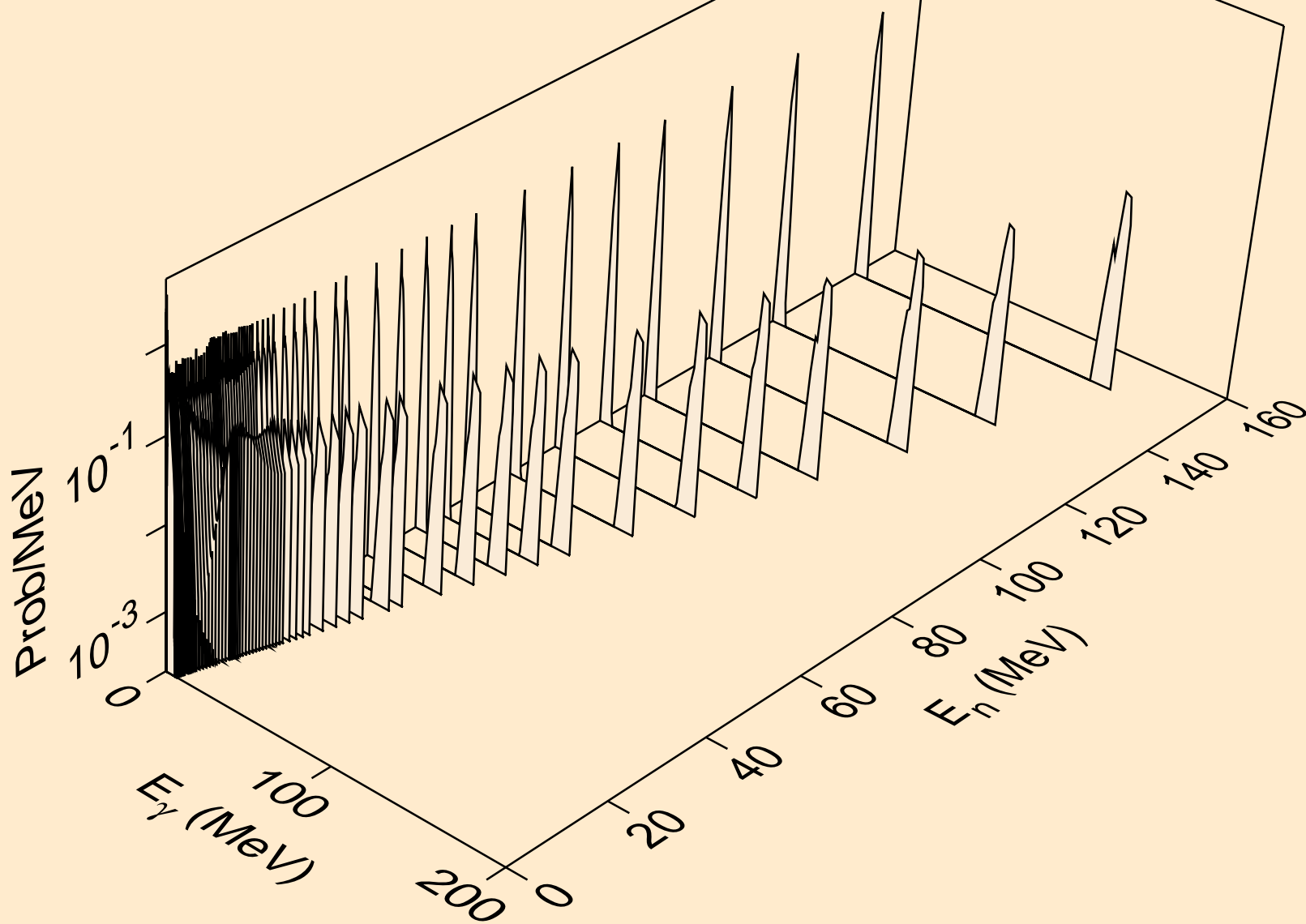

74-W-182 FOR FENDL-3.1 FROM INDLV-3 WITH NJOY2012.50+ C
Photon emission for (n,p*c)

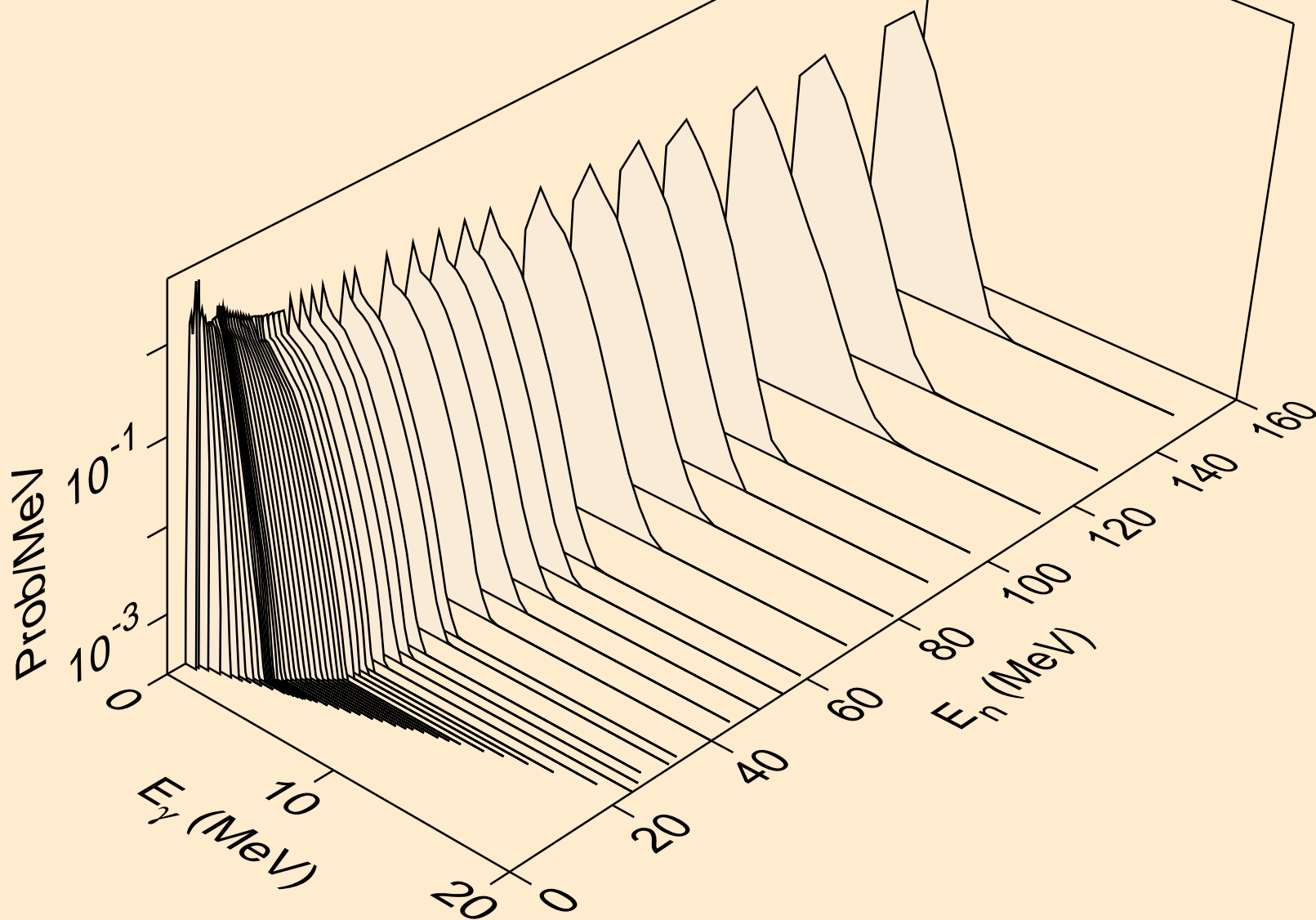

74-W-182 FOR FENDL-3.1 FROM INDLV-3 WITH NJOY2012.50+ C
Photon emission for (n,a*c)

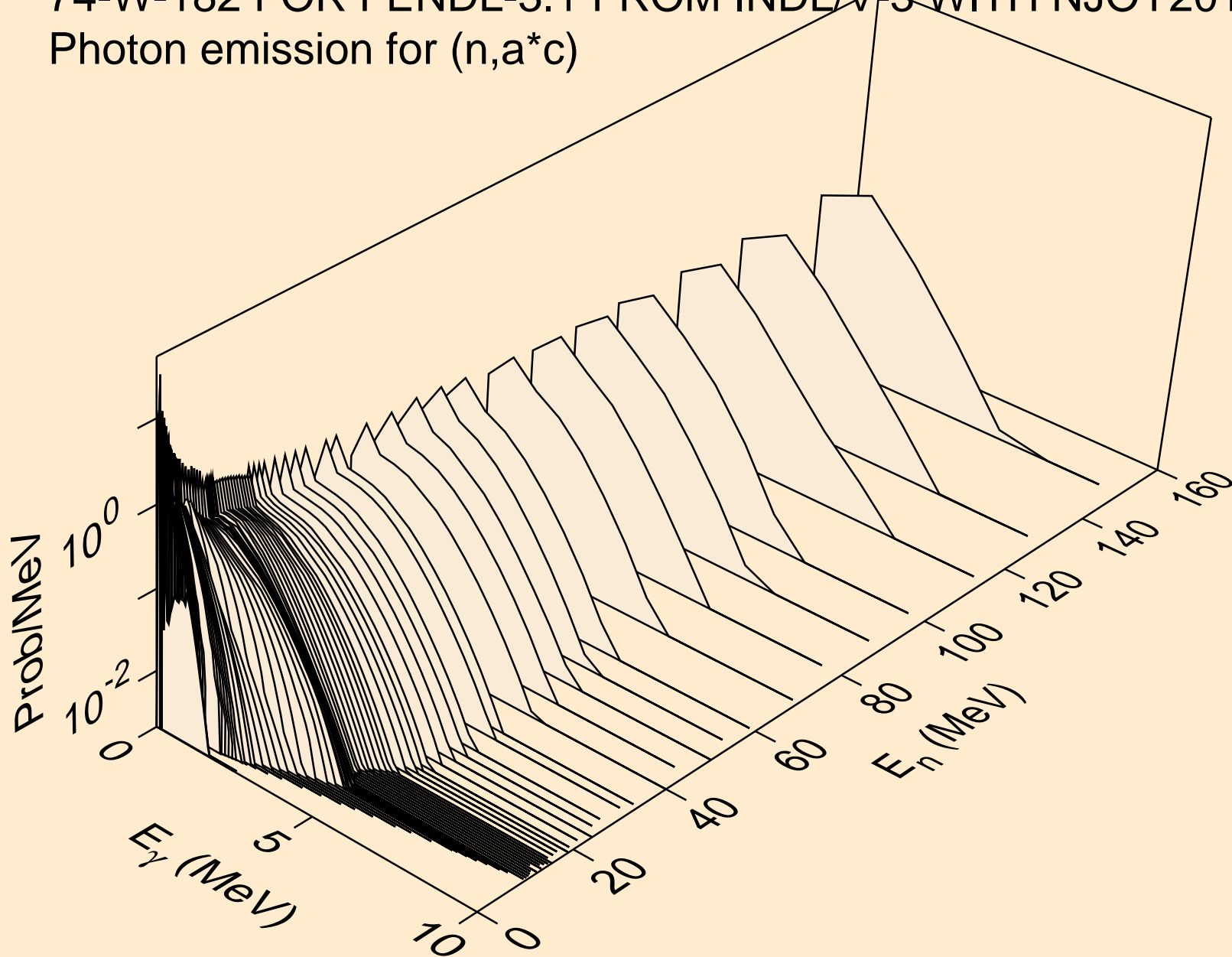

74-W-182 FOR FENDL-3.1 FROM INDL/V-3 WITH NJOY2012.50+ C
thermal capture photon spectrum

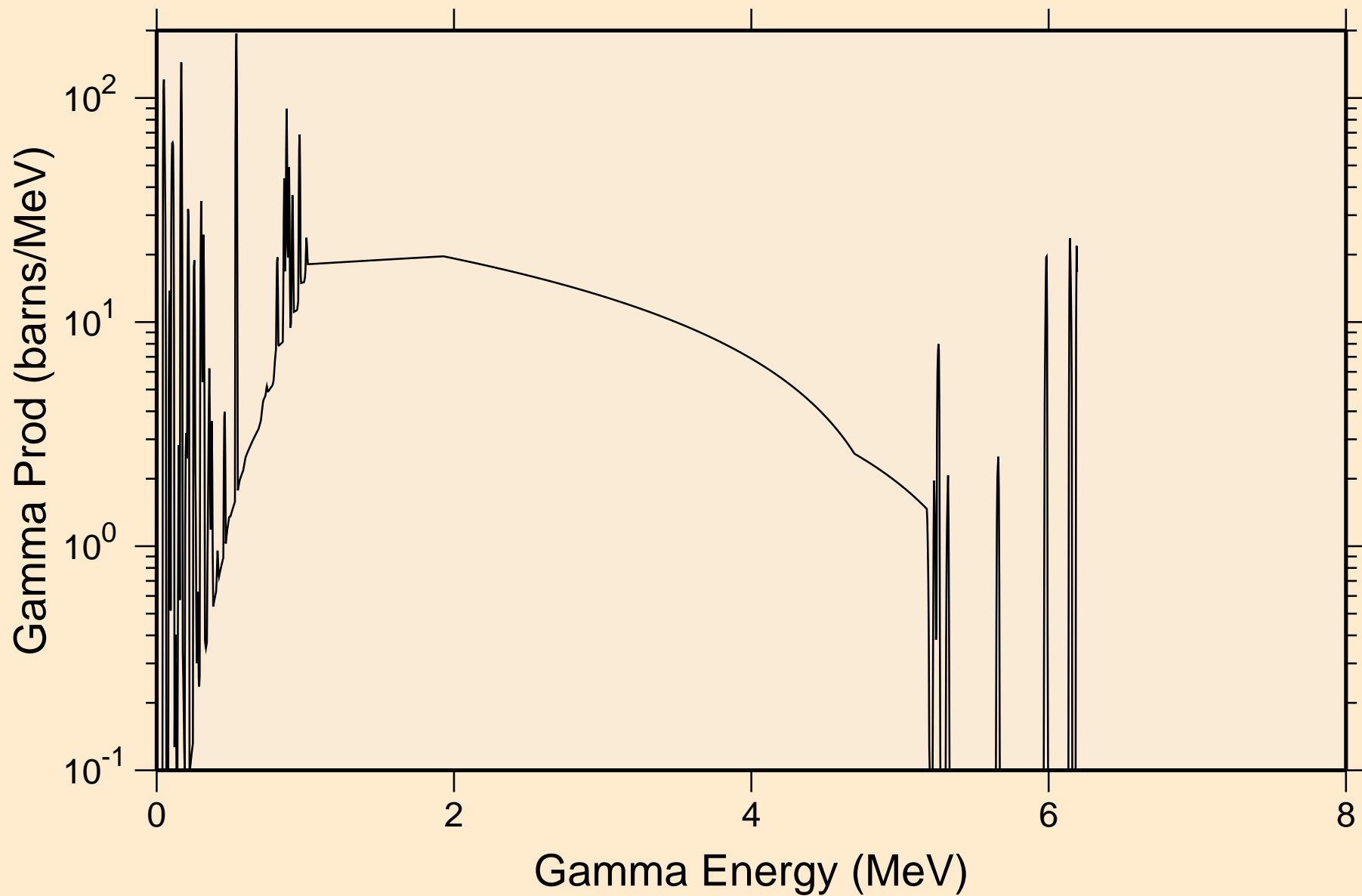

74-W-182 FOR FENDL-3.1 FROM INDL/V-3 WITH NJOY2012.50+ C
14 MeV photon spectrum

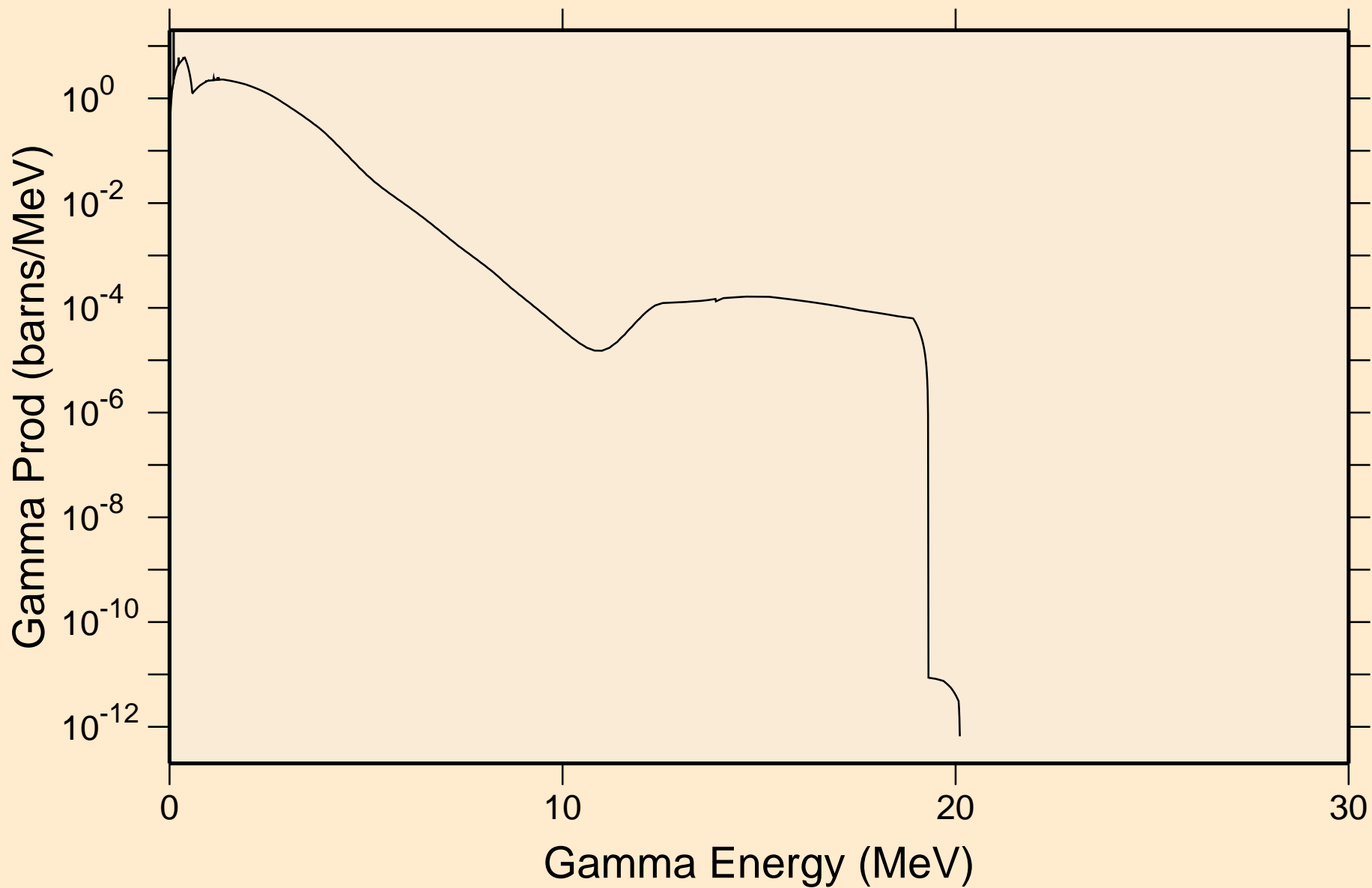

74-W-182 FOR FENDL-3.1 FROM INDL/V-3 WITH NJOY2012.50+ C

Particle heating contributions

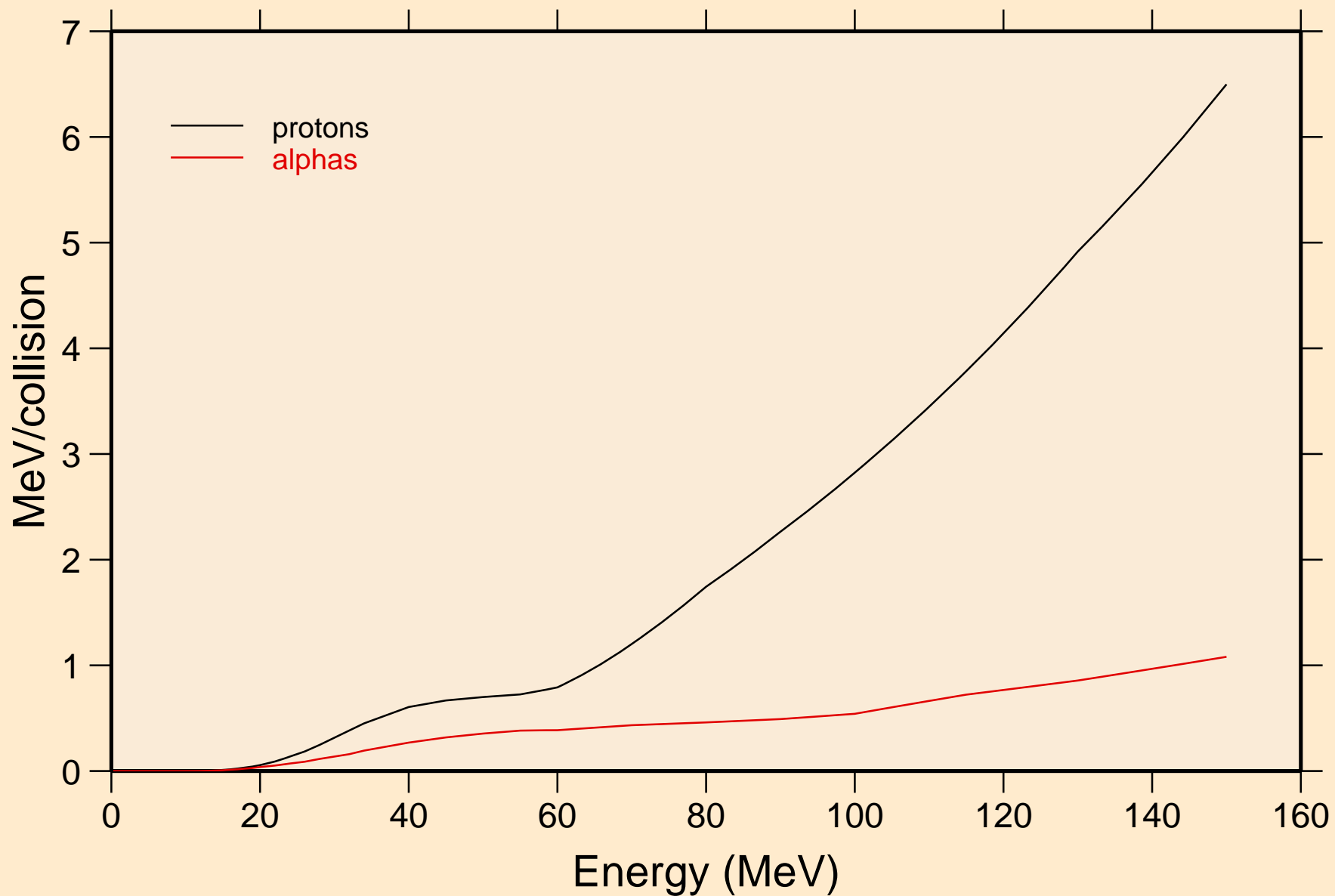

74-W-182 FOR FENDL-3.1 FROM INDL/V-3 WITH NJOY2012.50+ C Recoil Heating

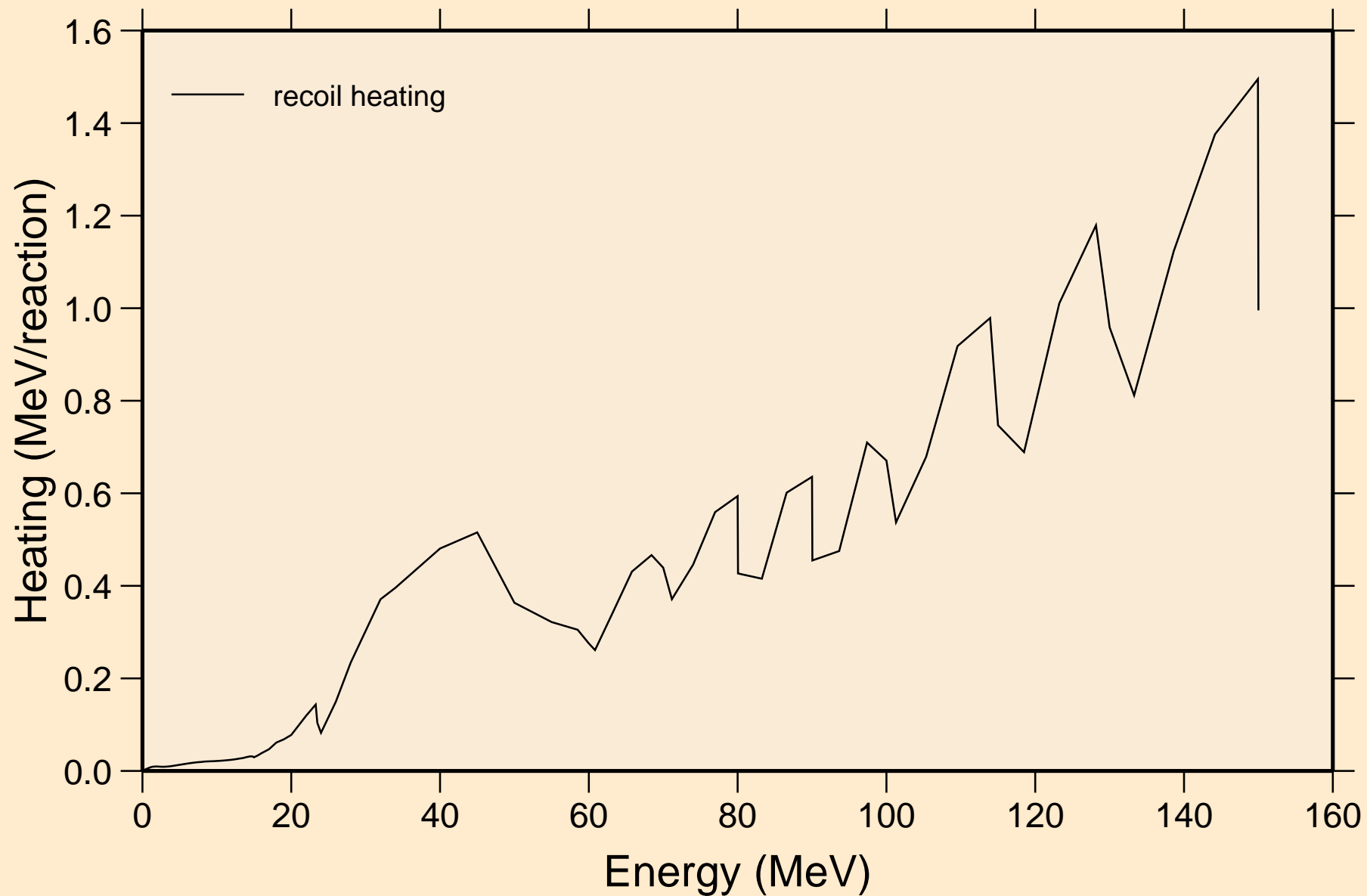

74-W-182 FOR FENDL-3.1 FROM INDL/V-3 WITH NJOY2012.50+ C
Particle production cross sections

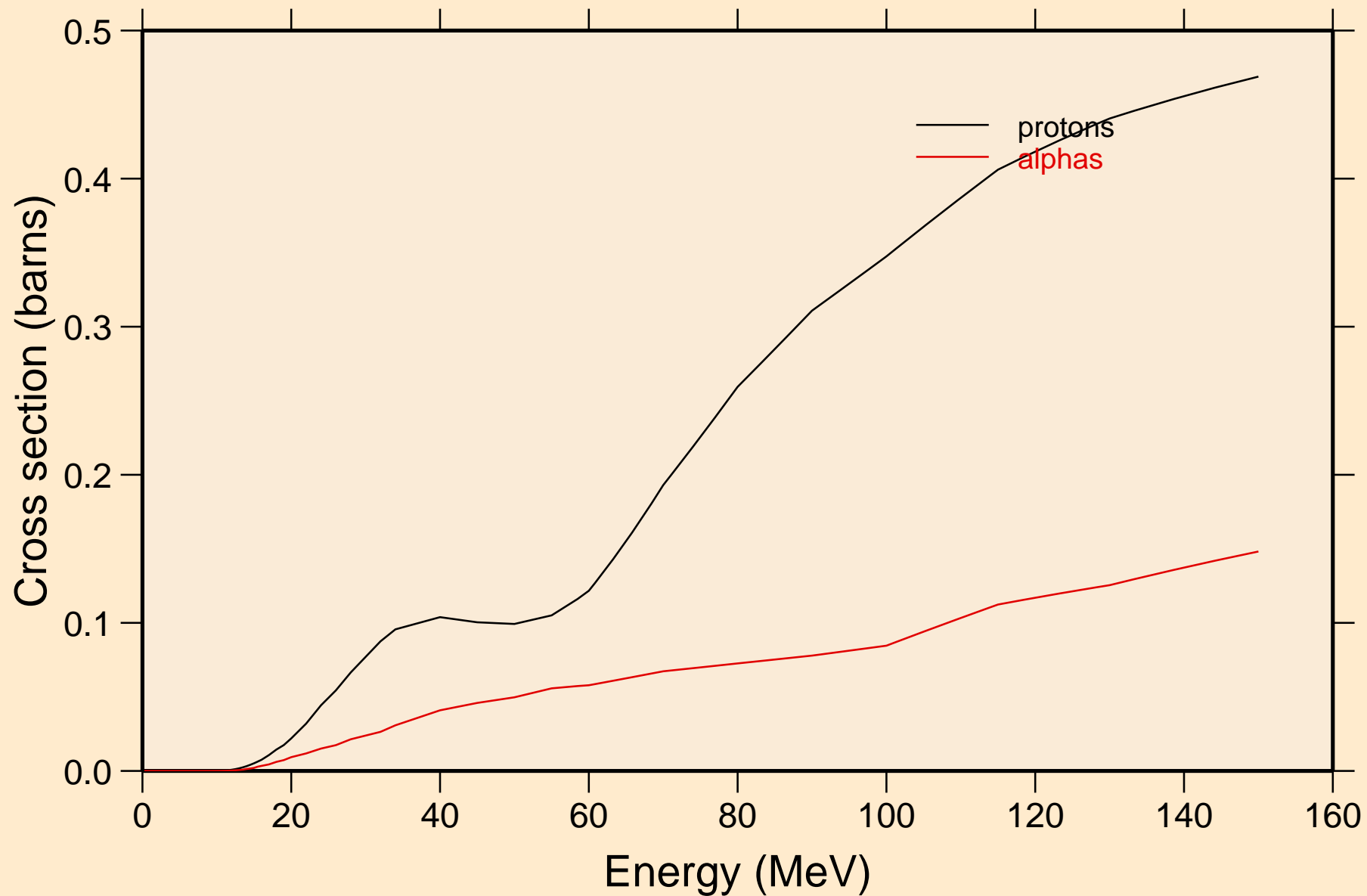

74-W-182 FOR FENDL-3.1 FROM INDLV-3 WITH NJOY2012.50+ C
protons from (n,x)

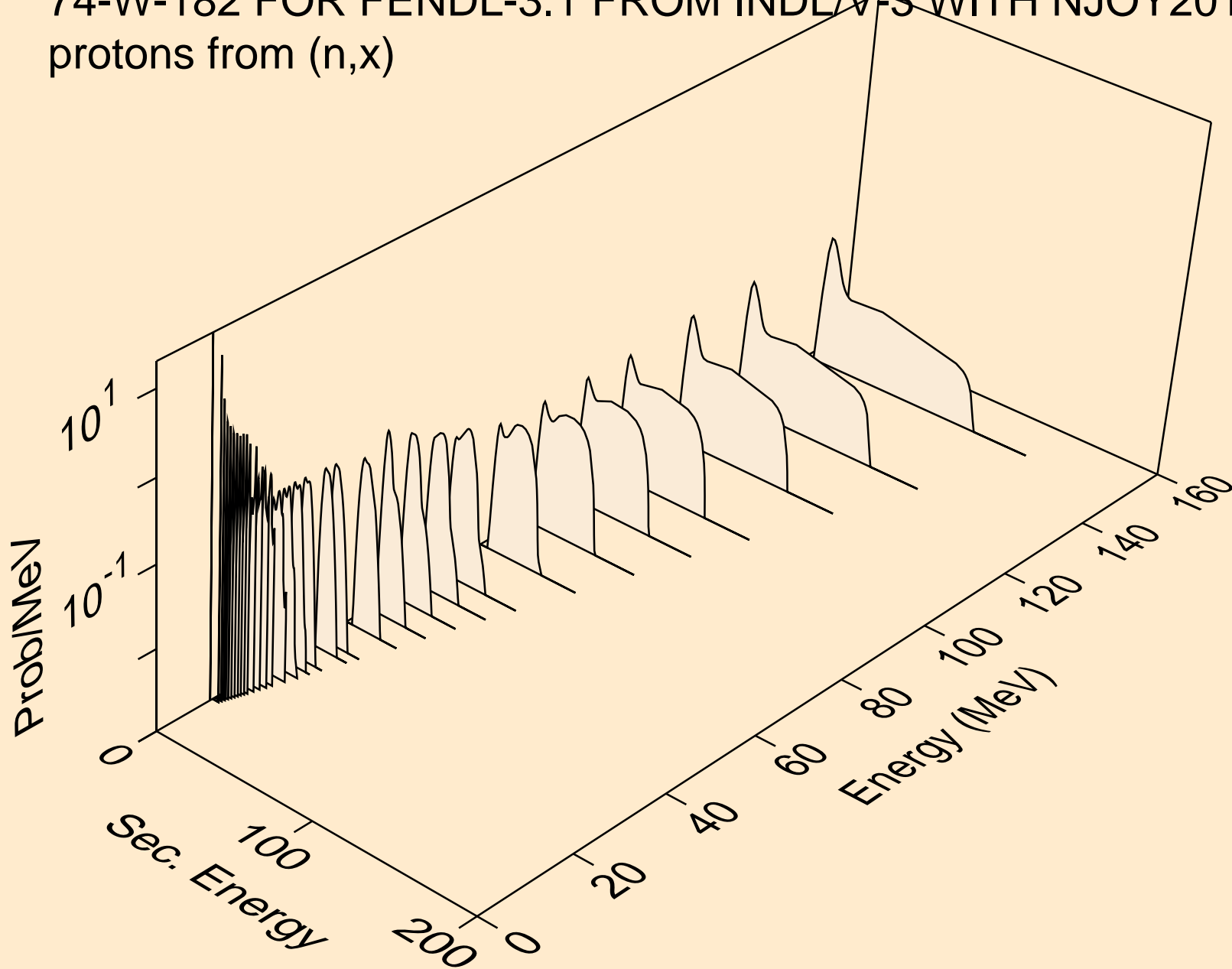

74-W-182 FOR FENDL-3.1 FROM INDLV-3 WITH NJOY2012.50+ C
protons from (n,n*)p

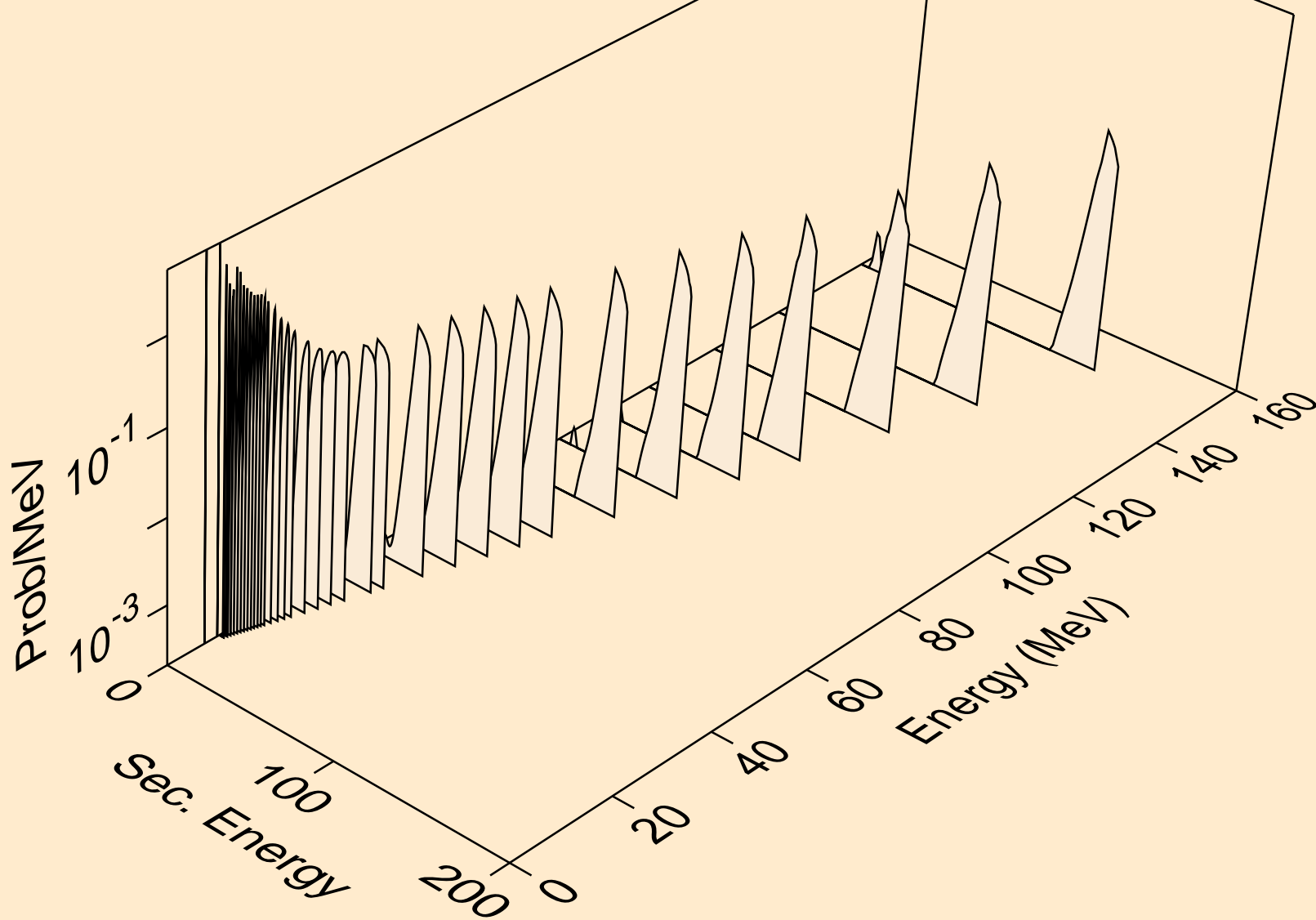

74-W-182 FOR FENDL-3.1 FROM INDLV-3 WITH NJOY2012.50+ C
protons from (n,2np)

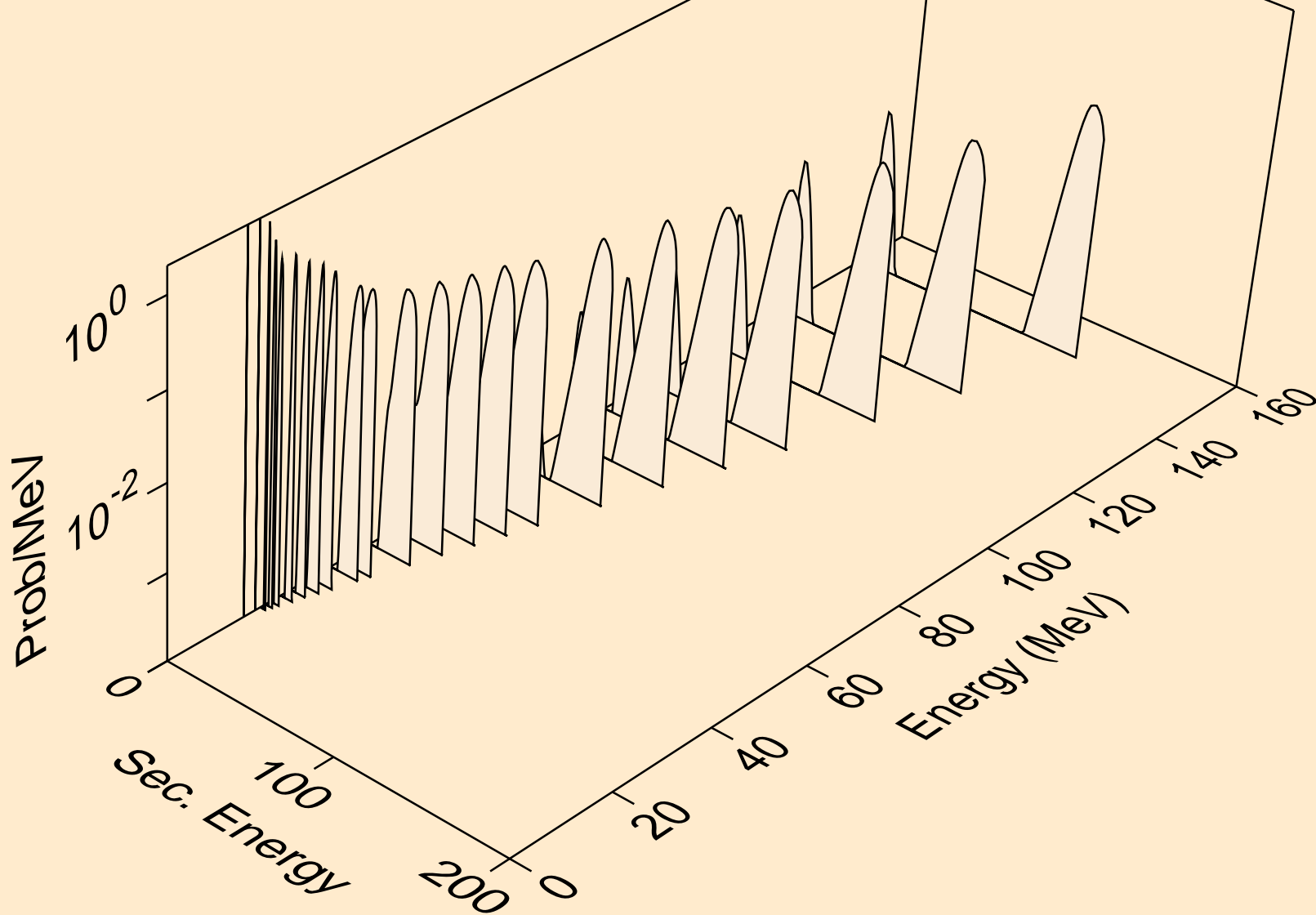

74-W-182 FOR FENDL-3.1 FROM INDL/V-3 WITH NJOY2012.50+ C
angular distribution for (n,p*0) proton

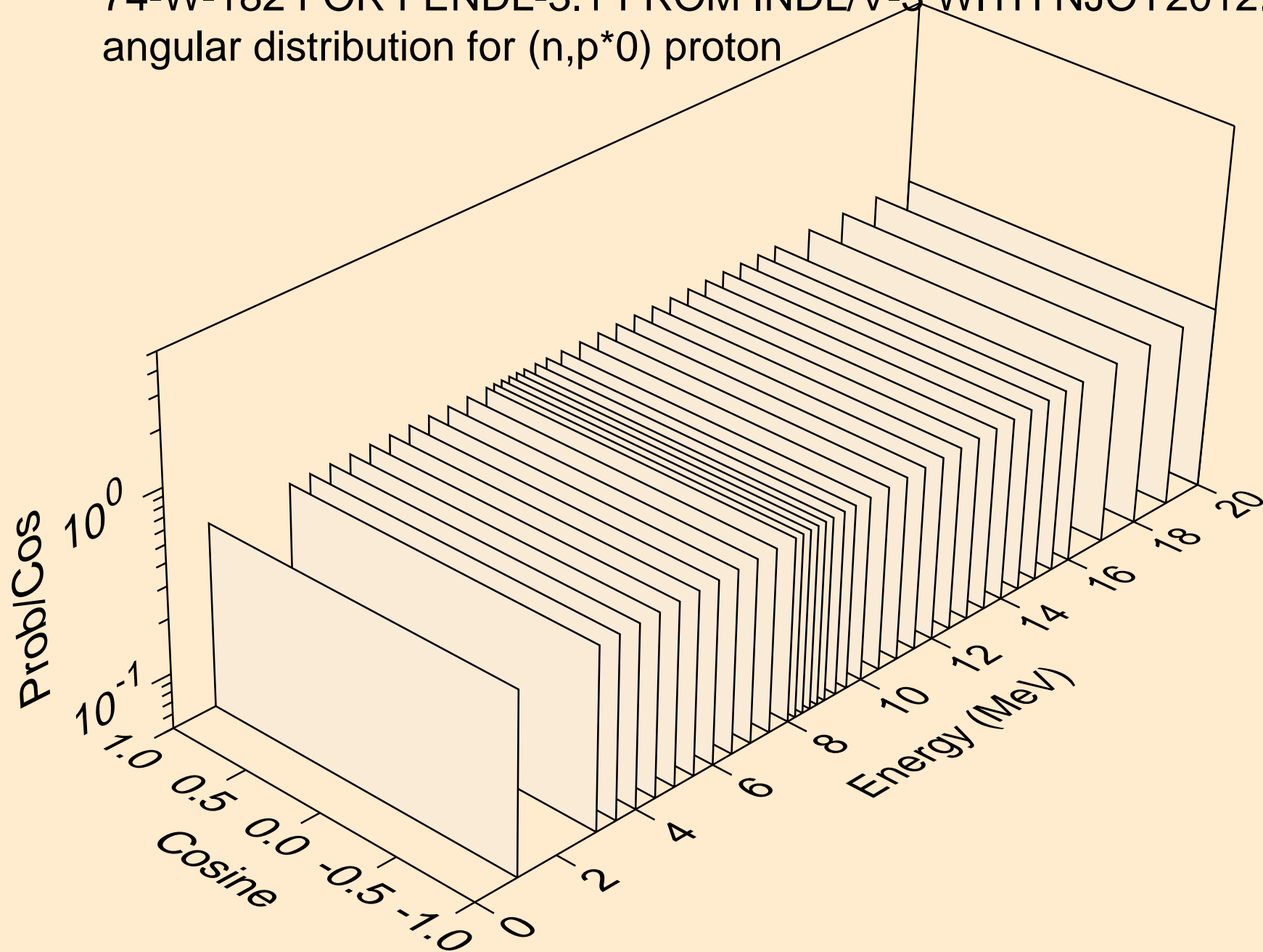

74-W-182 FOR FENDL-3.1 FROM INDL/V-3 WITH NJOY2012.50+ C
angular distribution for (n,p*0) proton

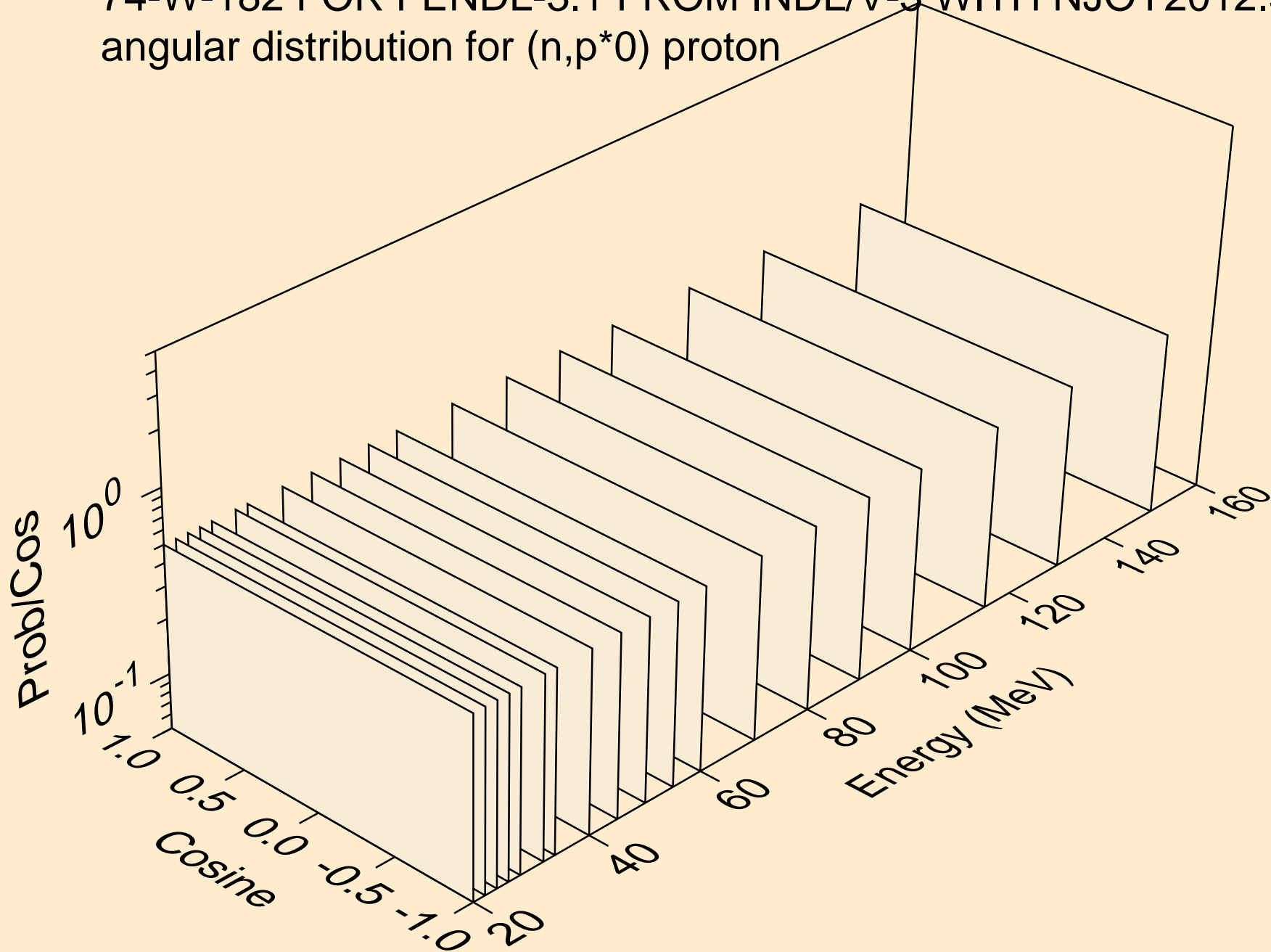

74-W-182 FOR FENDL-3.1 FROM INDL/V-3 WITH NJOY2012.50+ C
angular distribution for (n,p*1) proton

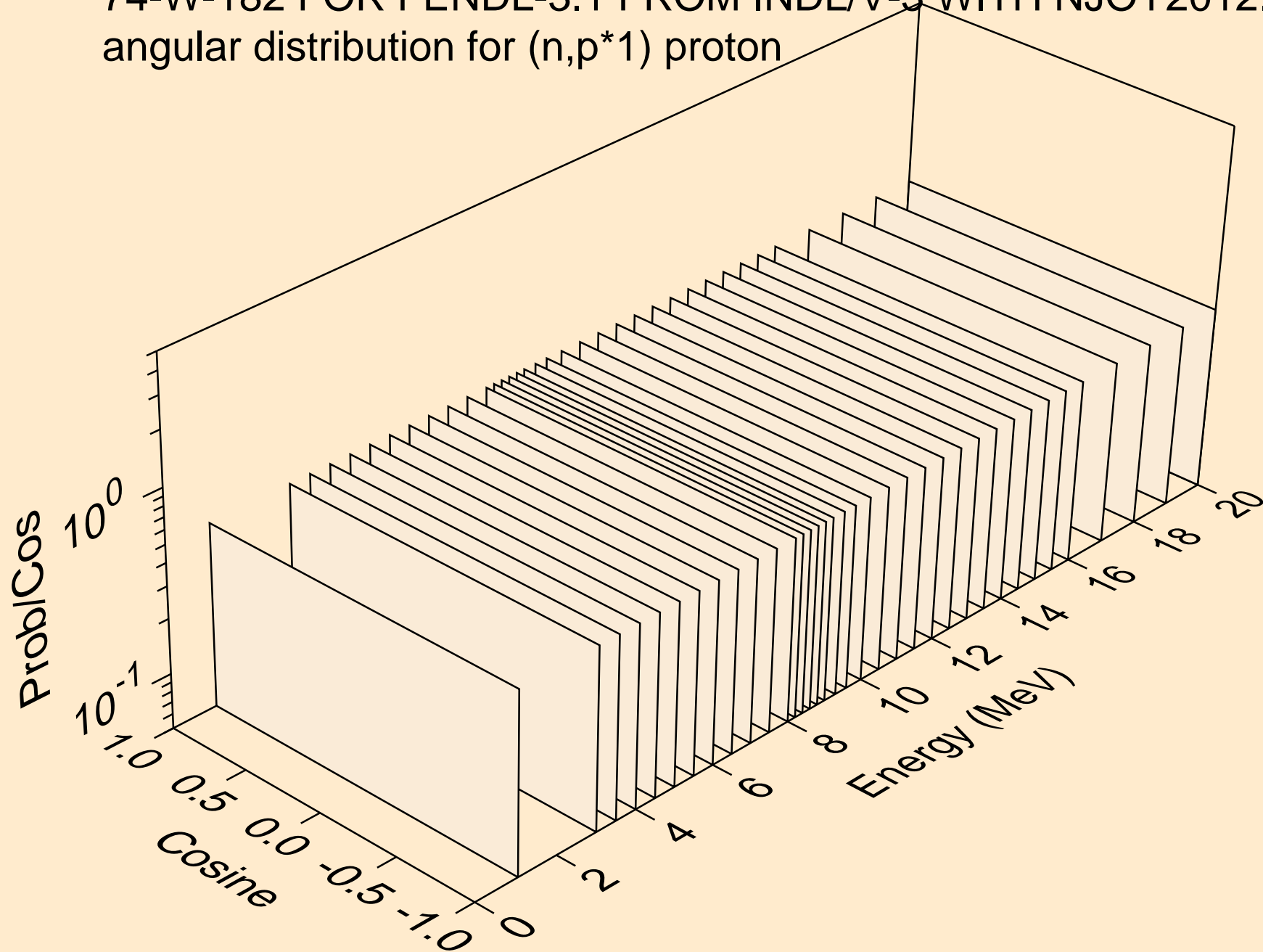

74-W-182 FOR FENDL-3.1 FROM INDL/V-3 WITH NJOY2012.50+ C
angular distribution for (n,p*1) proton

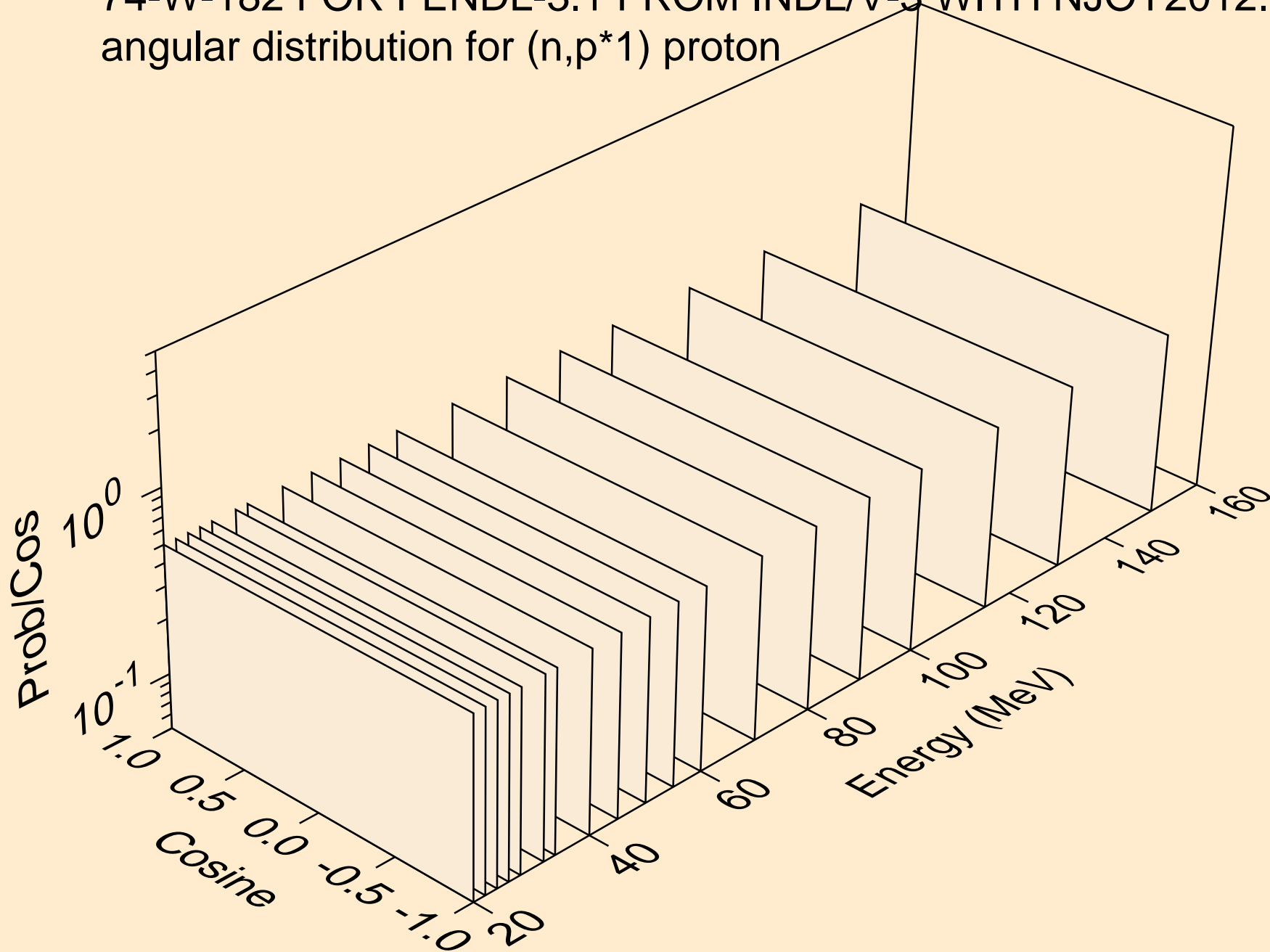

74-W-182 FOR FENDL-3.1 FROM INDL/V-3 WITH NJOY2012.50+ C
angular distribution for (n,p*2) proton

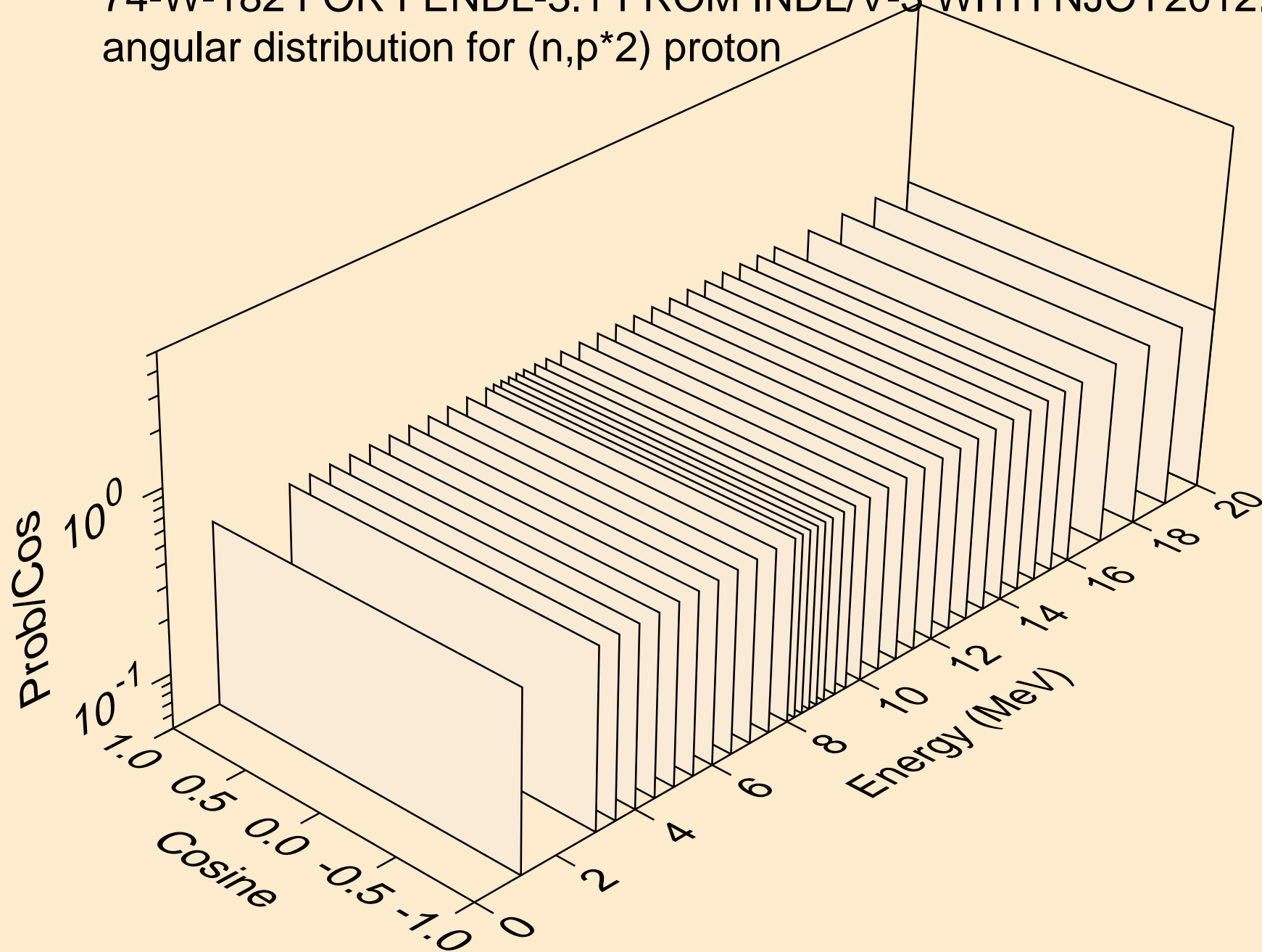

74-W-182 FOR FENDL-3.1 FROM INDL/V-3 WITH NJOY2012.50+ C
angular distribution for (n,p*2) proton

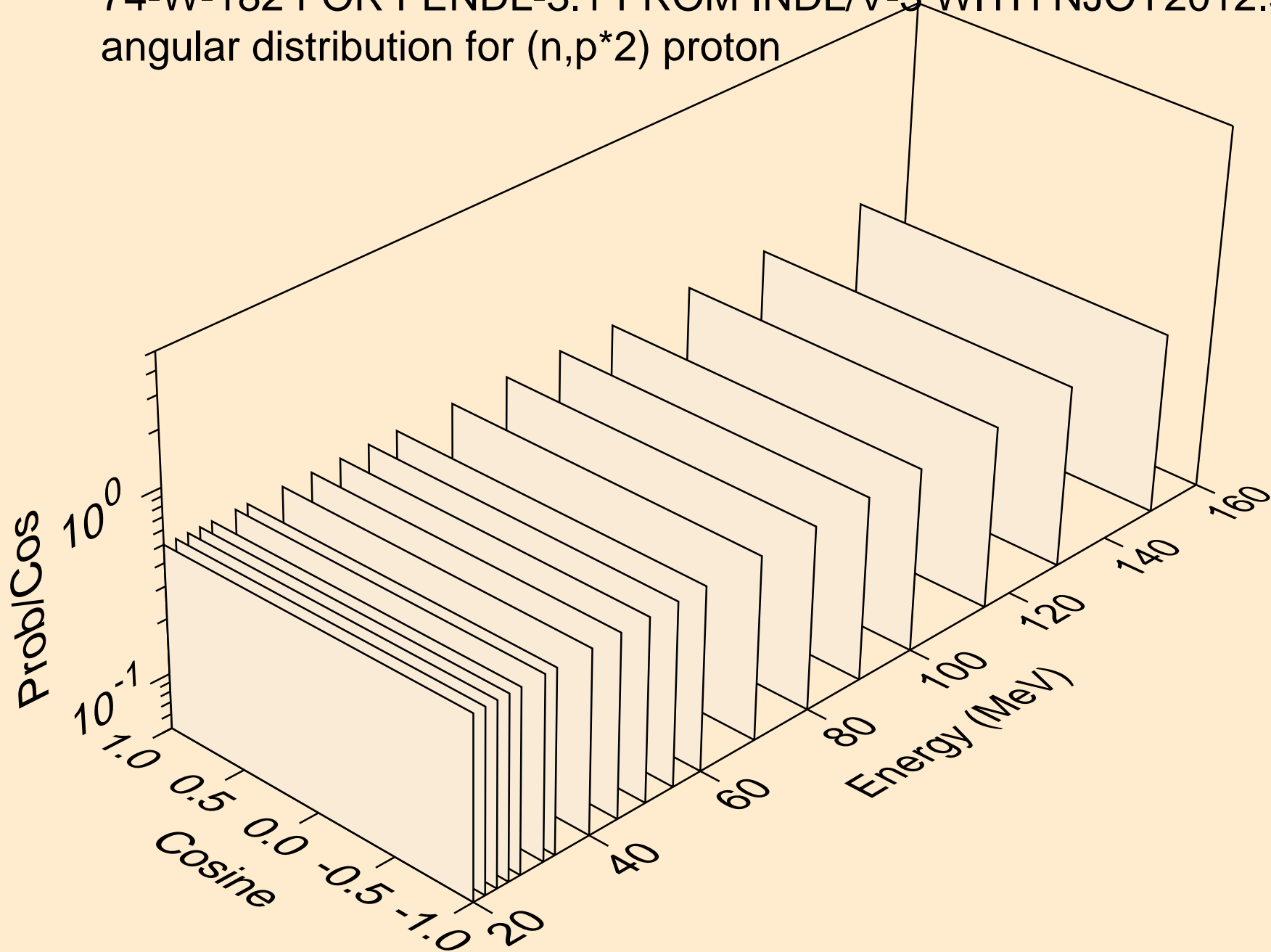

74-W-182 FOR FENDL-3.1 FROM INDL/V-3 WITH NJOY2012.50+ C
angular distribution for (n,p*3) proton

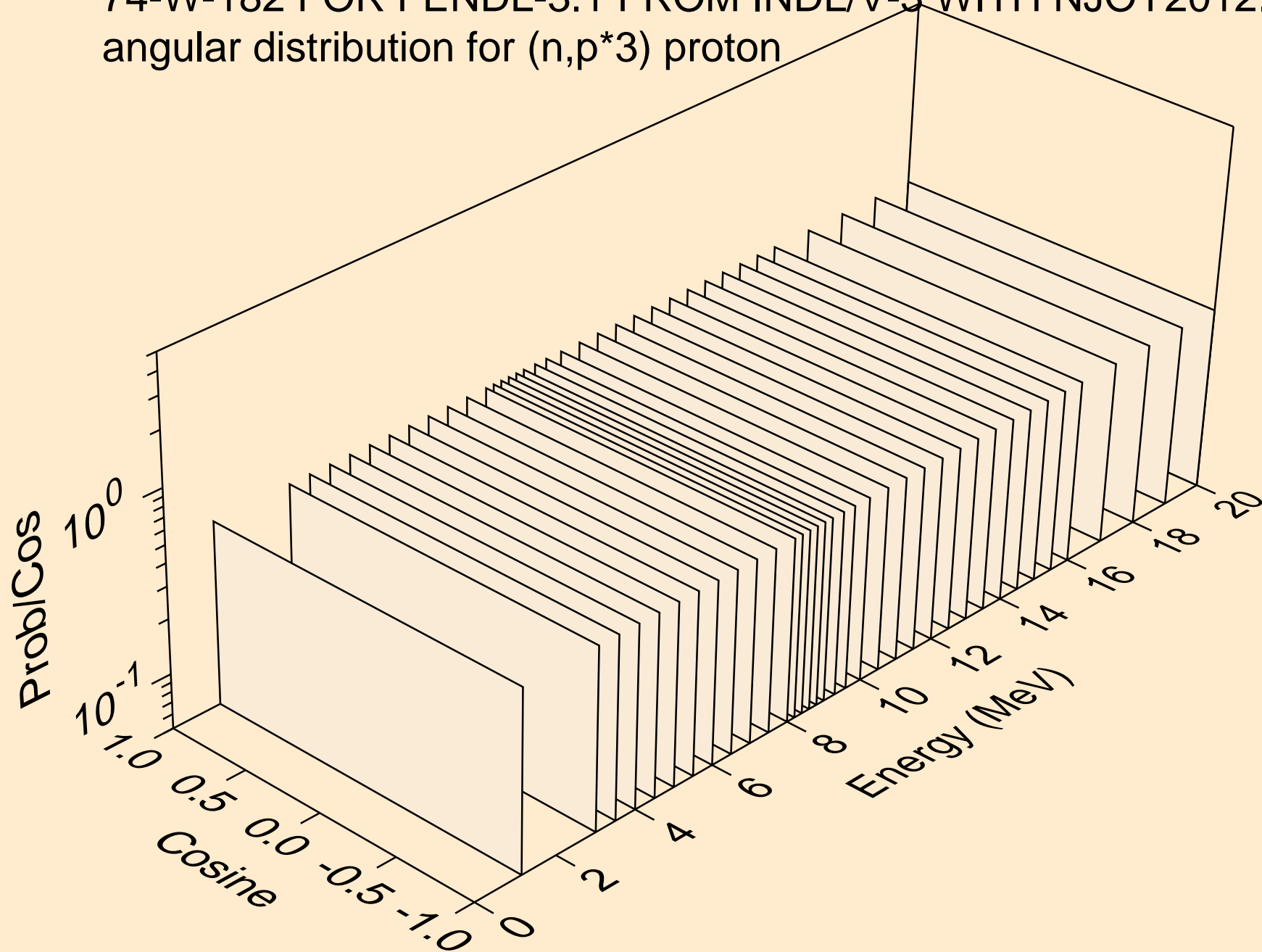

74-W-182 FOR FENDL-3.1 FROM INDL/V-3 WITH NJOY2012.50+ C
angular distribution for (n,p*3) proton

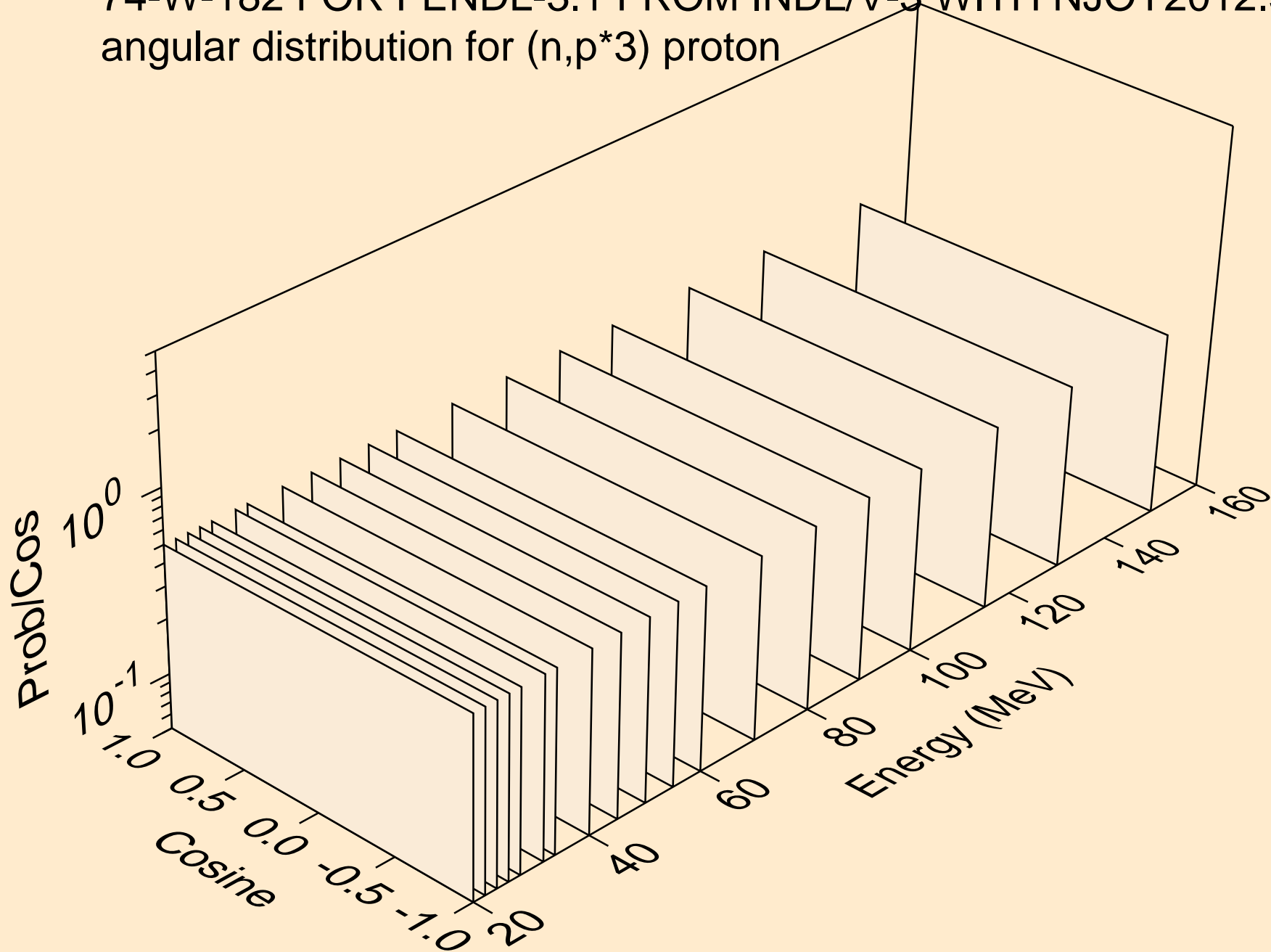

74-W-182 FOR FENDL-3.1 FROM INDL/V-3 WITH NJOY2012.50+ C
angular distribution for (n,p*4) proton

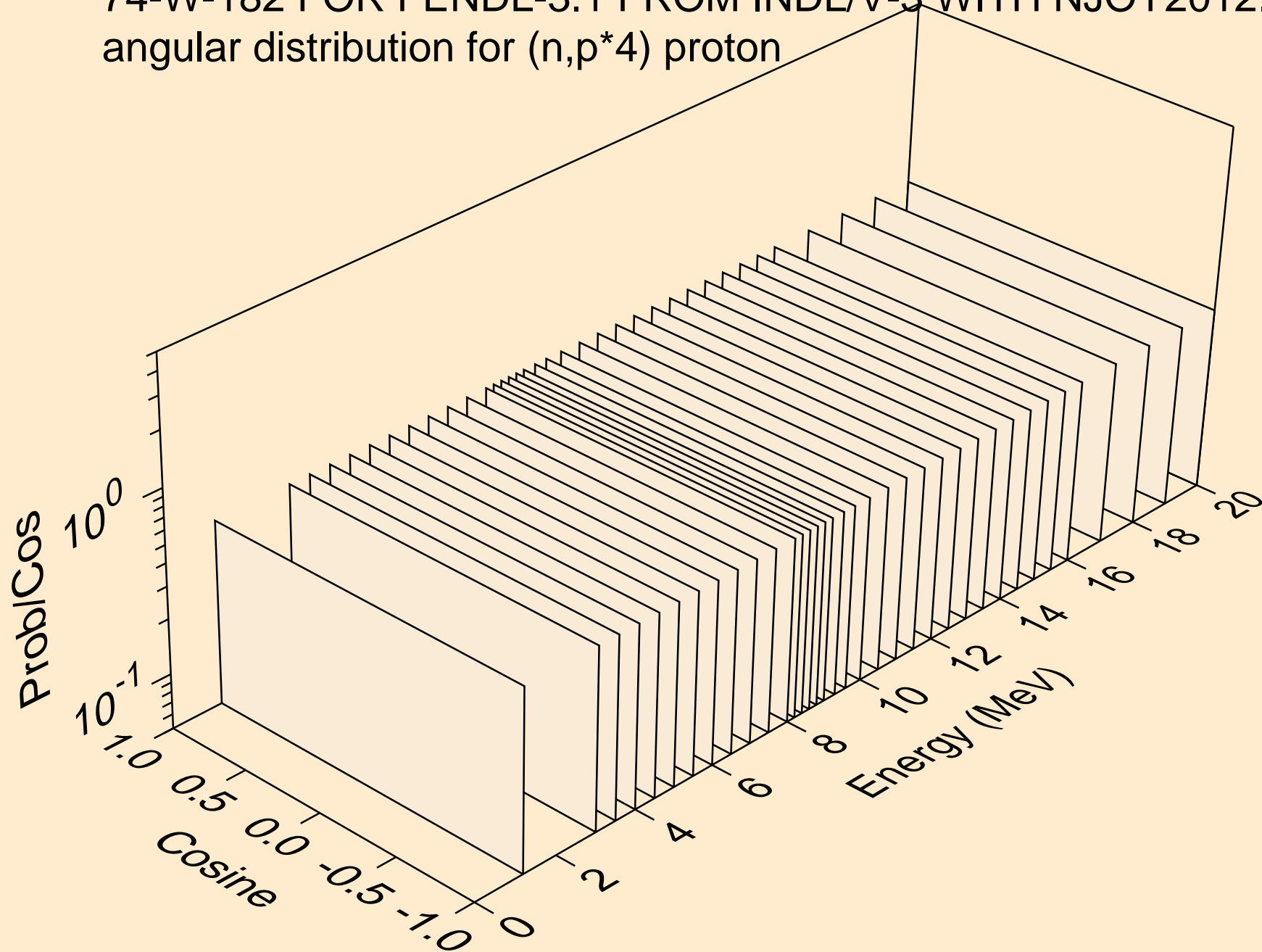

74-W-182 FOR FENDL-3.1 FROM INDL/V-3 WITH NJOY2012.50+ C
angular distribution for (n,p*4) proton

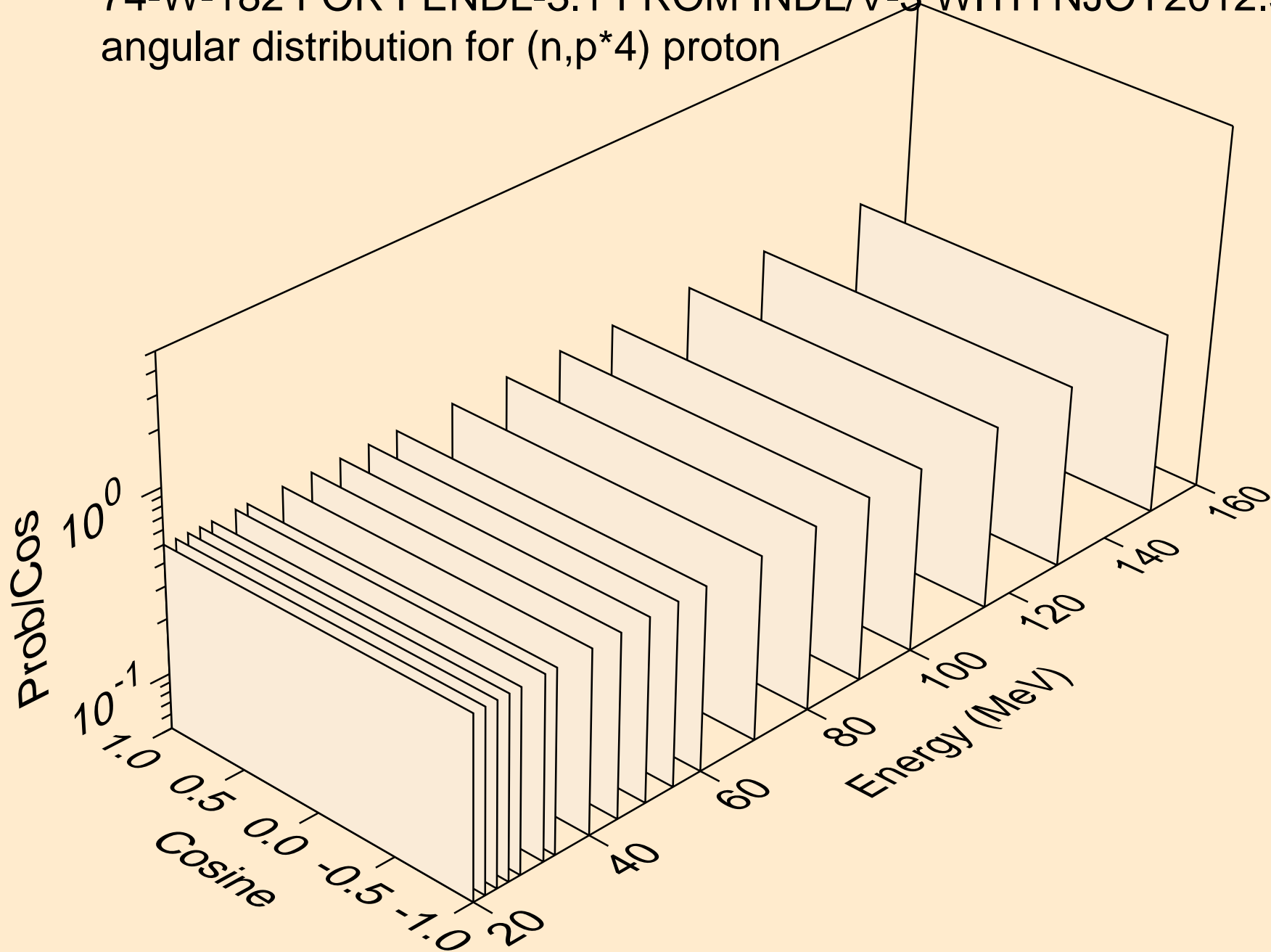

74-W-182 FOR FENDL-3.1 FROM INDL/V-3 WITH NJOY2012.50+ C
angular distribution for (n,p*5) proton

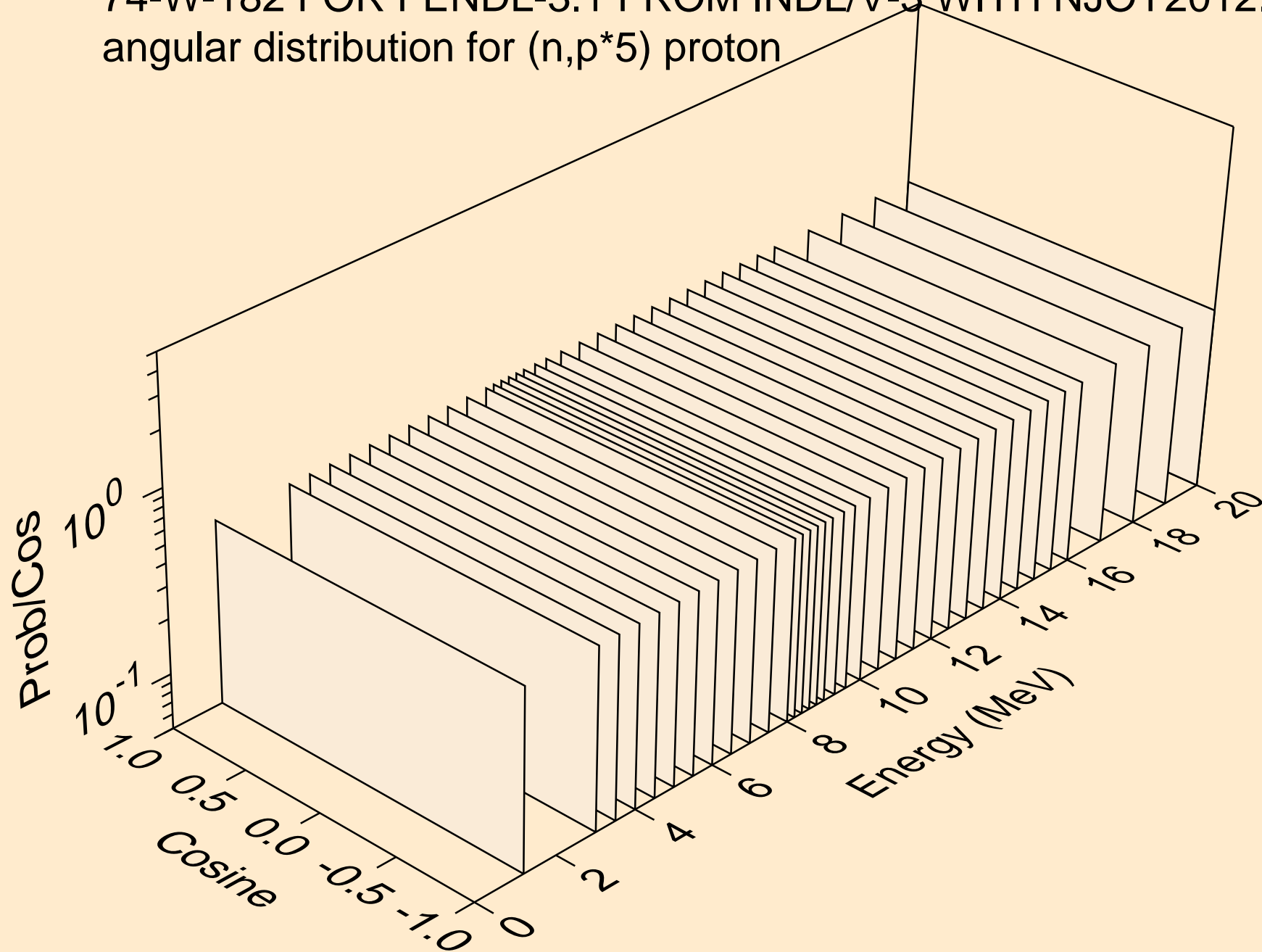

74-W-182 FOR FENDL-3.1 FROM INDL/V-3 WITH NJOY2012.50+ C
angular distribution for (n,p*5) proton

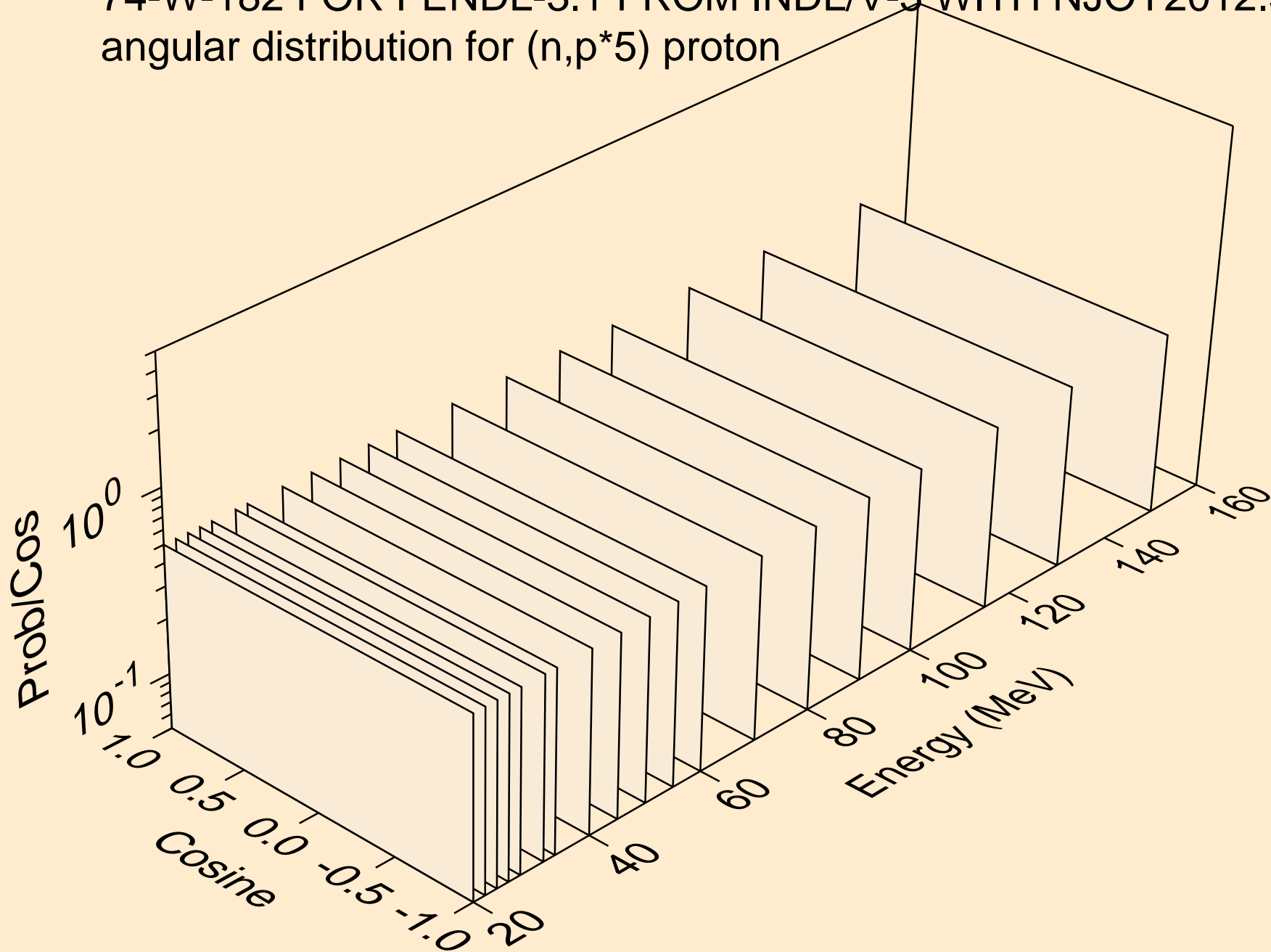

74-W-182 FOR FENDL-3.1 FROM INDL/V-3 WITH NJOY2012.50+ C
angular distribution for (n,p*6) proton

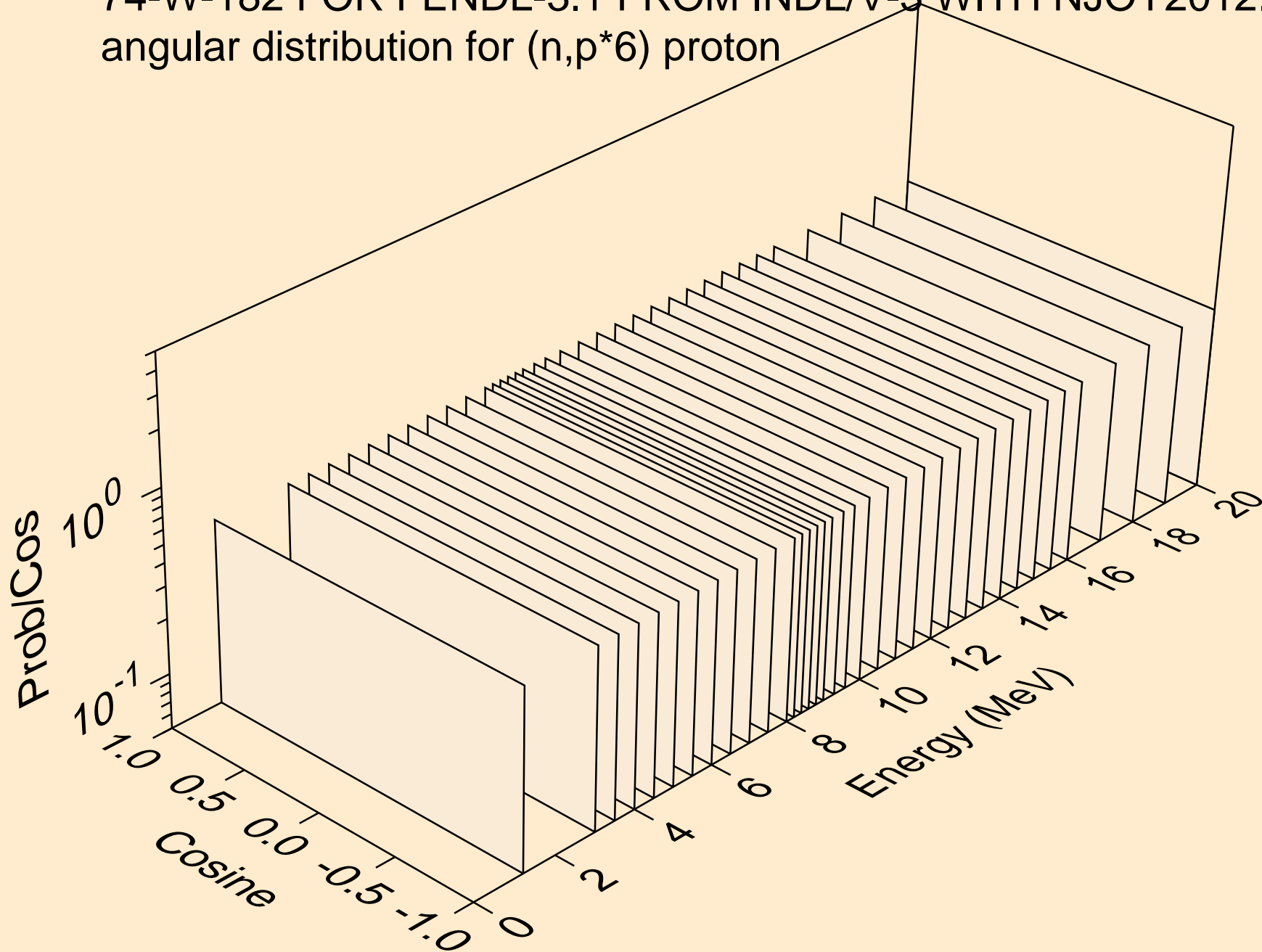

74-W-182 FOR FENDL-3.1 FROM INDL/V-3 WITH NJOY2012.50+ C
angular distribution for (n,p*6) proton

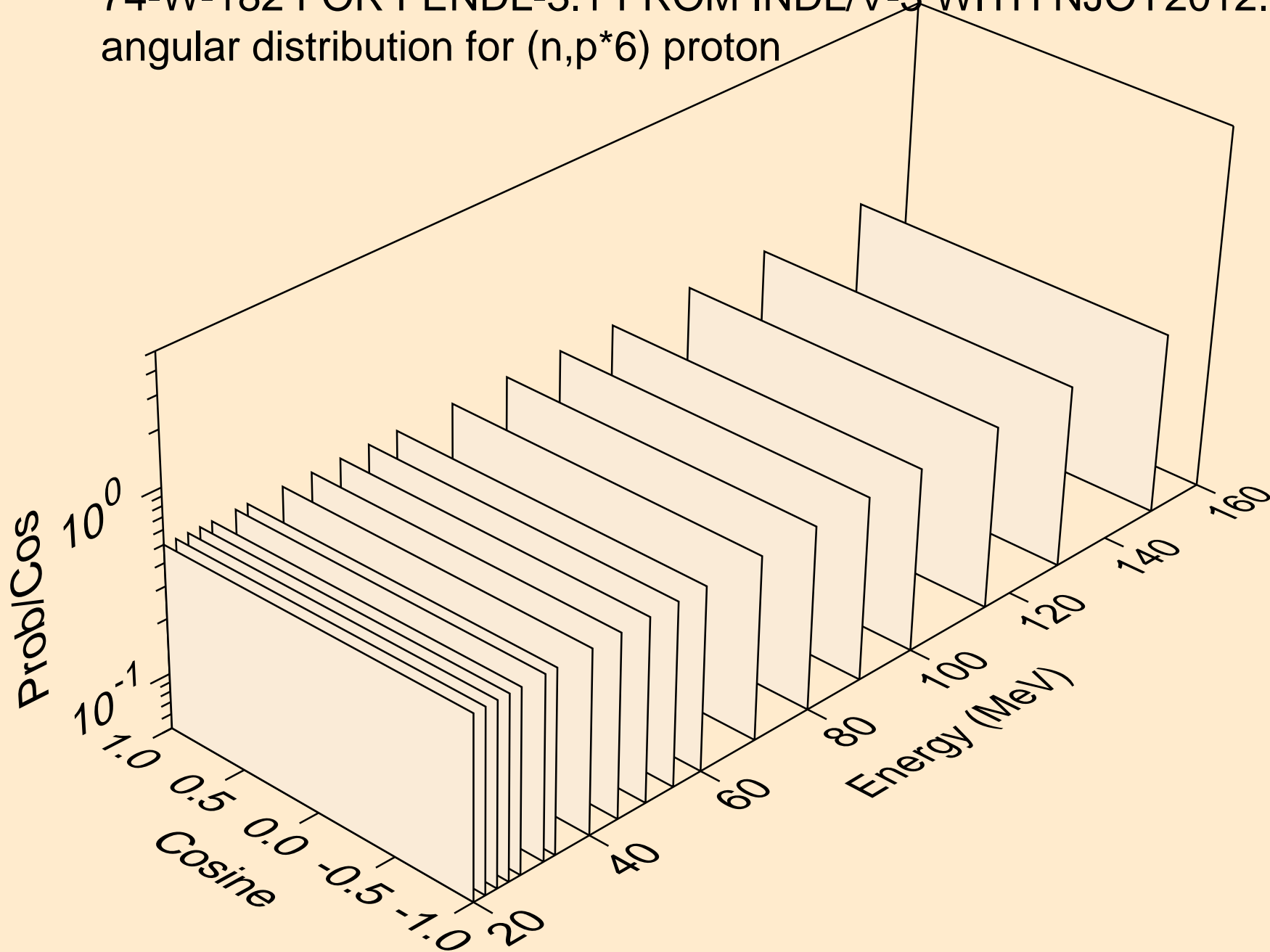

74-W-182 FOR FENDL-3.1 FROM INDL/V-3 WITH NJOY2012.50+ C
angular distribution for (n,p*7) proton

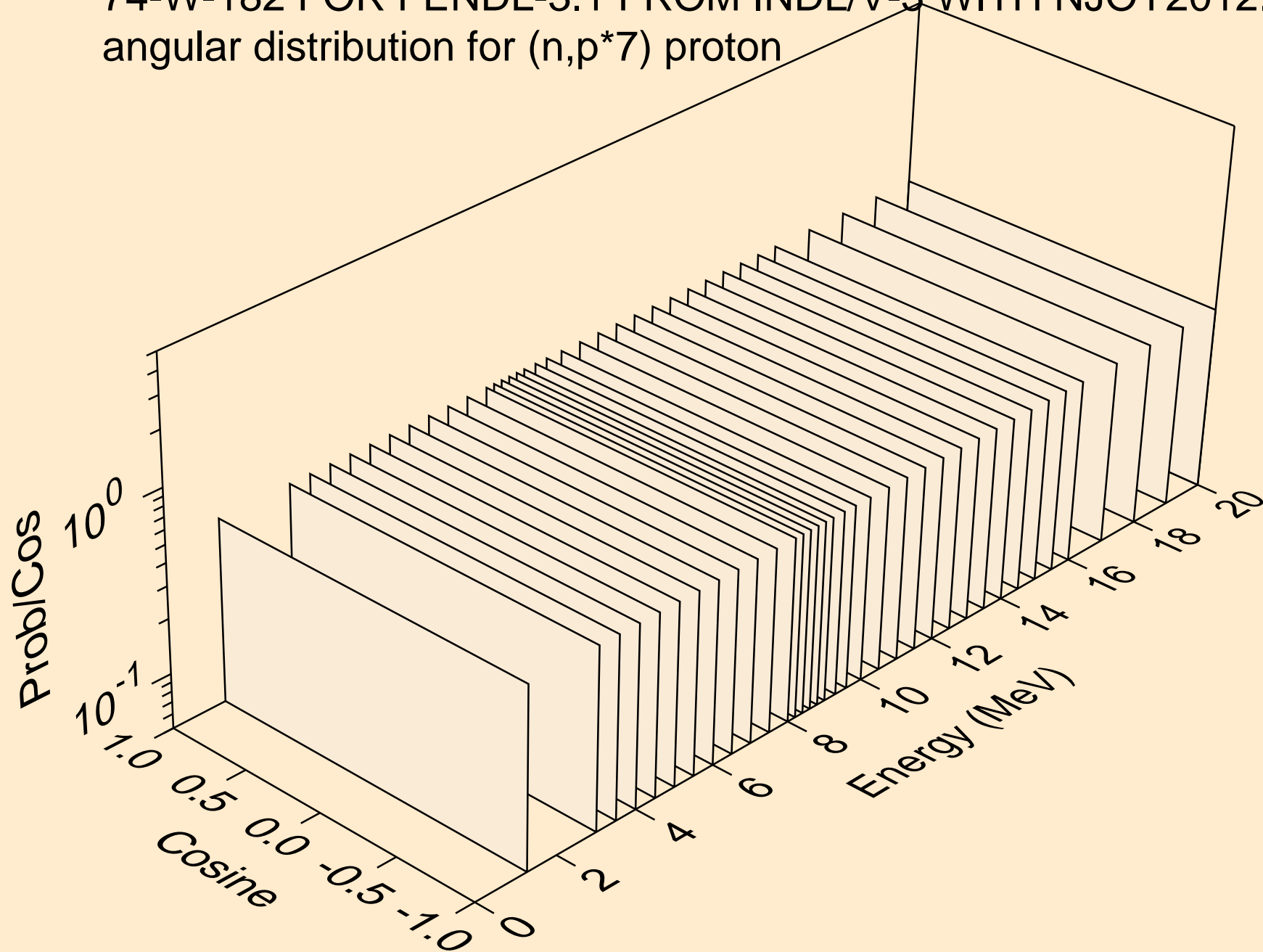

74-W-182 FOR FENDL-3.1 FROM INDL/V-3 WITH NJOY2012.50+ C
angular distribution for (n,p*7) proton

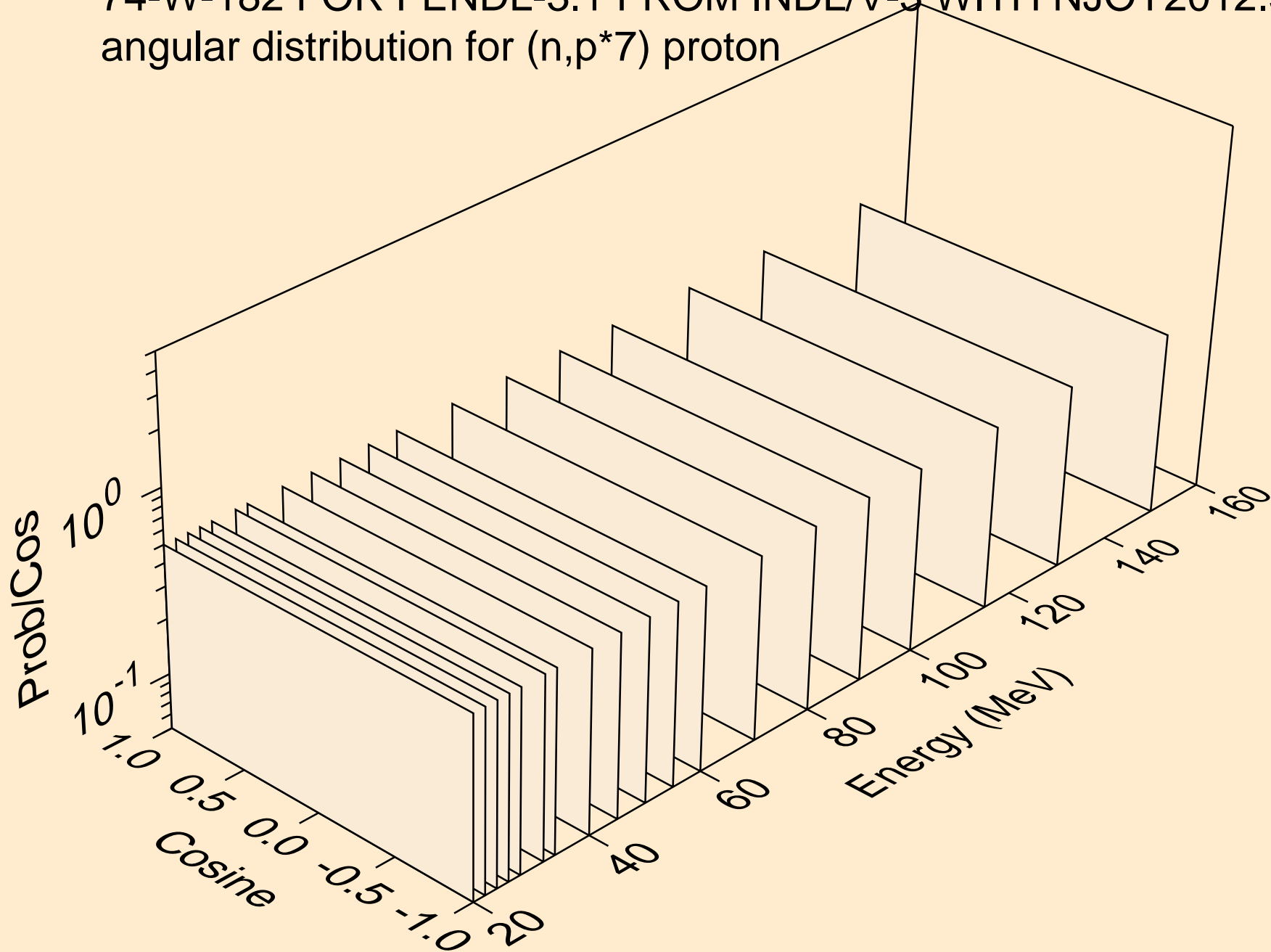

74-W-182 FOR FENDL-3.1 FROM INDL/V-3 WITH NJOY2012.50+ C
angular distribution for (n,p*8) proton

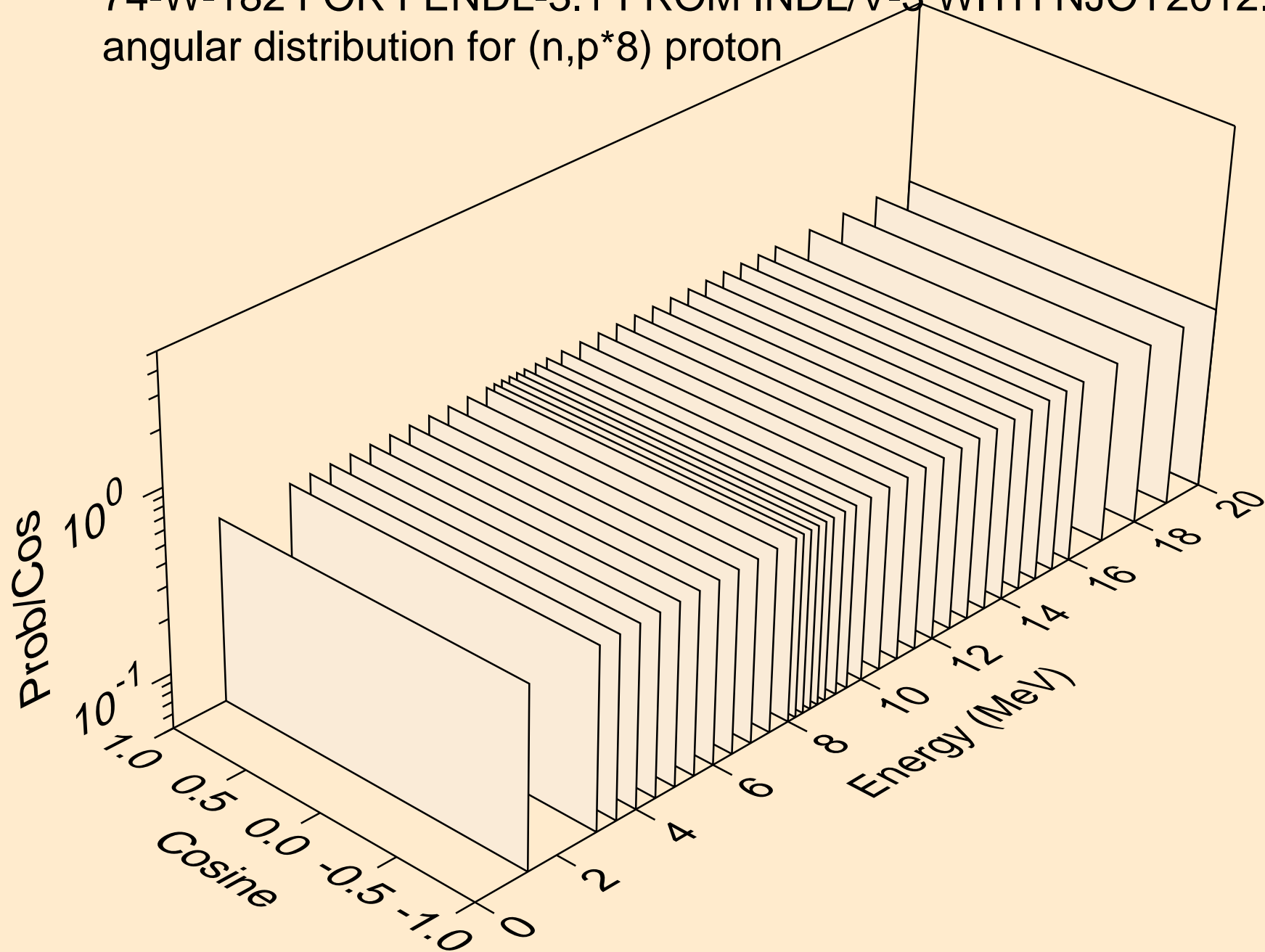

74-W-182 FOR FENDL-3.1 FROM INDL/V-3 WITH NJOY2012.50+ C
angular distribution for (n,p*8) proton

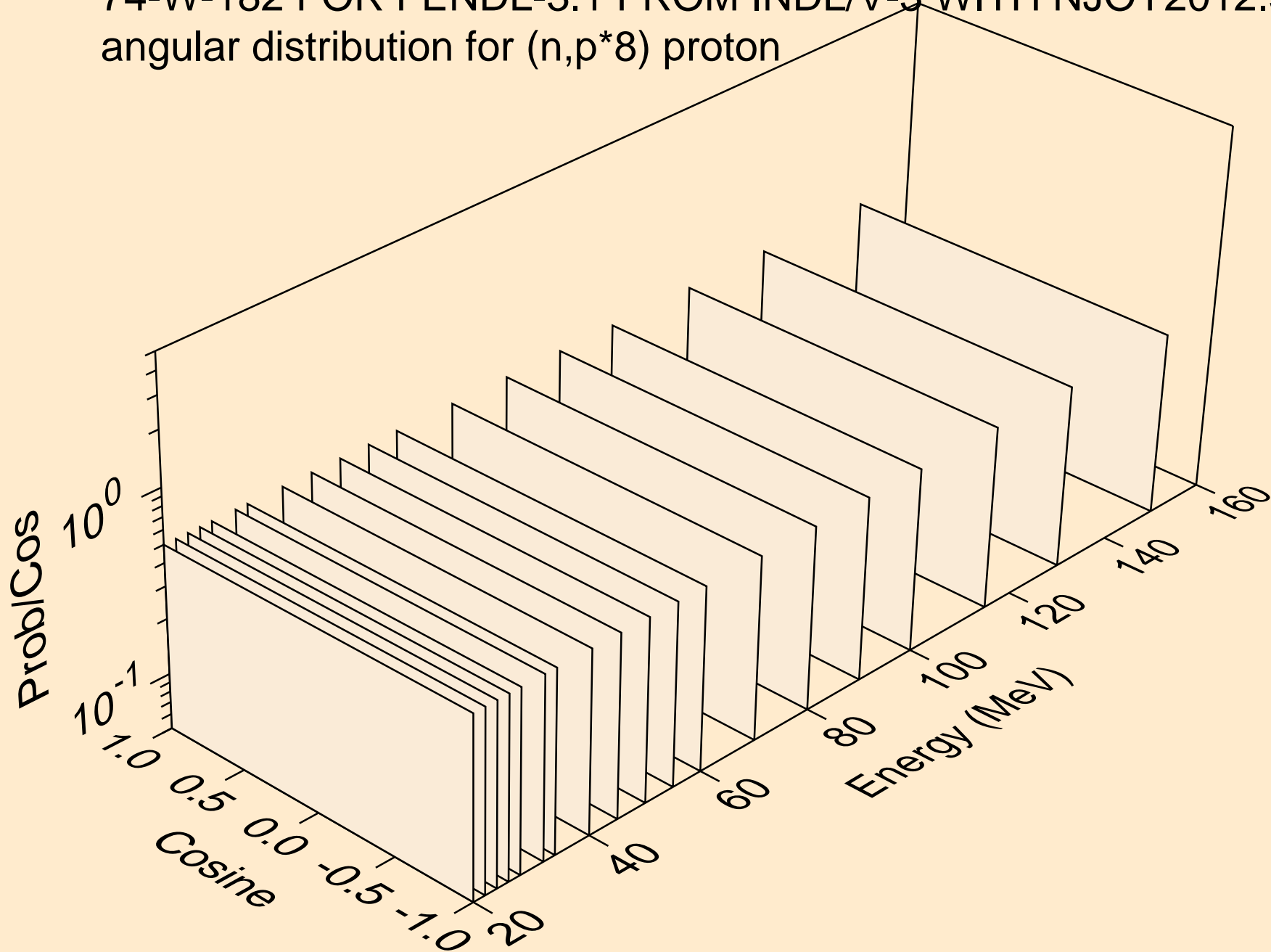

74-W-182 FOR FENDL-3.1 FROM INDL/V-3 WITH NJOY2012.50+ C
angular distribution for (n,p*9) proton

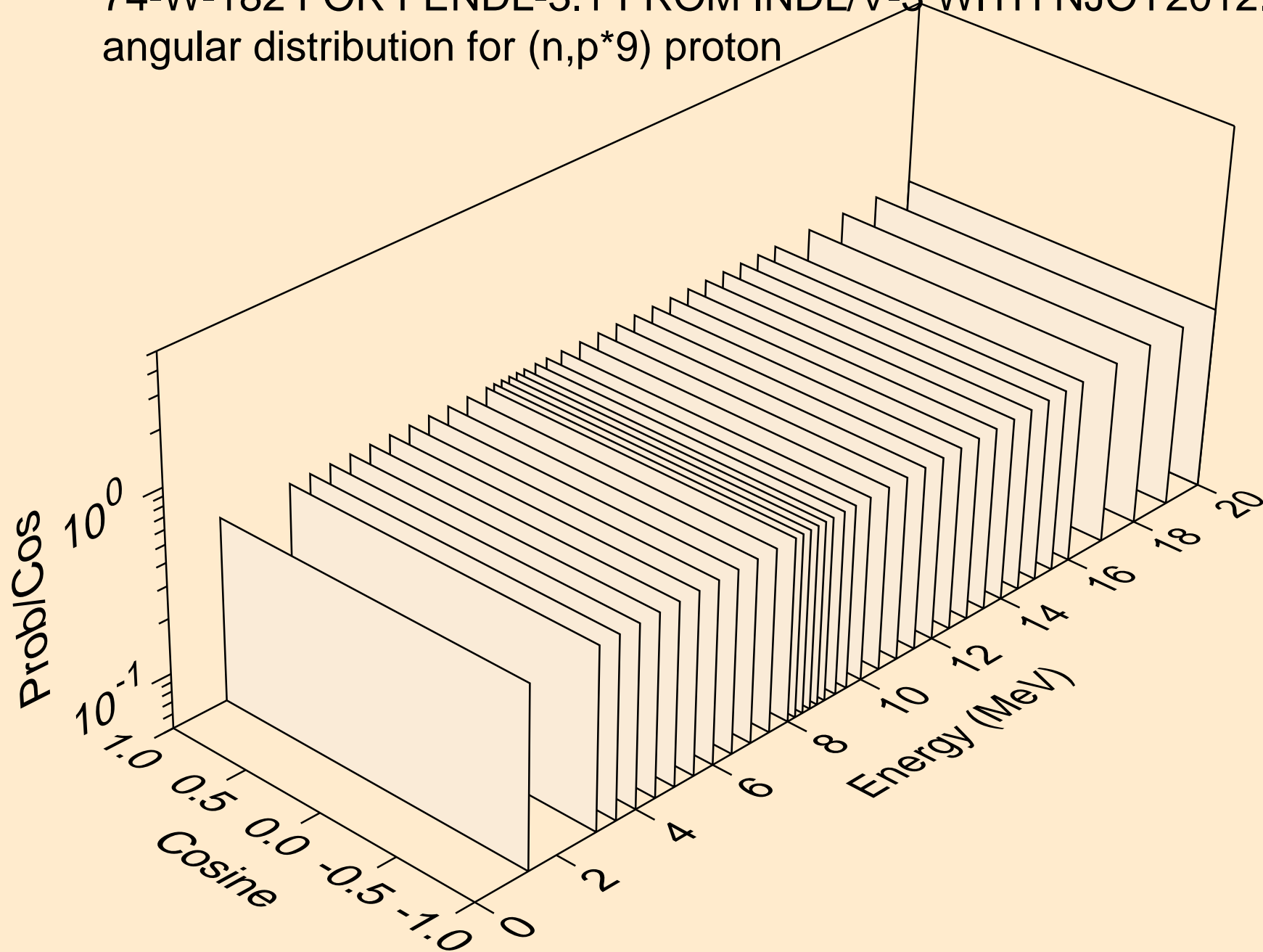

74-W-182 FOR FENDL-3.1 FROM INDL/V-3 WITH NJOY2012.50+ C
angular distribution for (n,p*9) proton

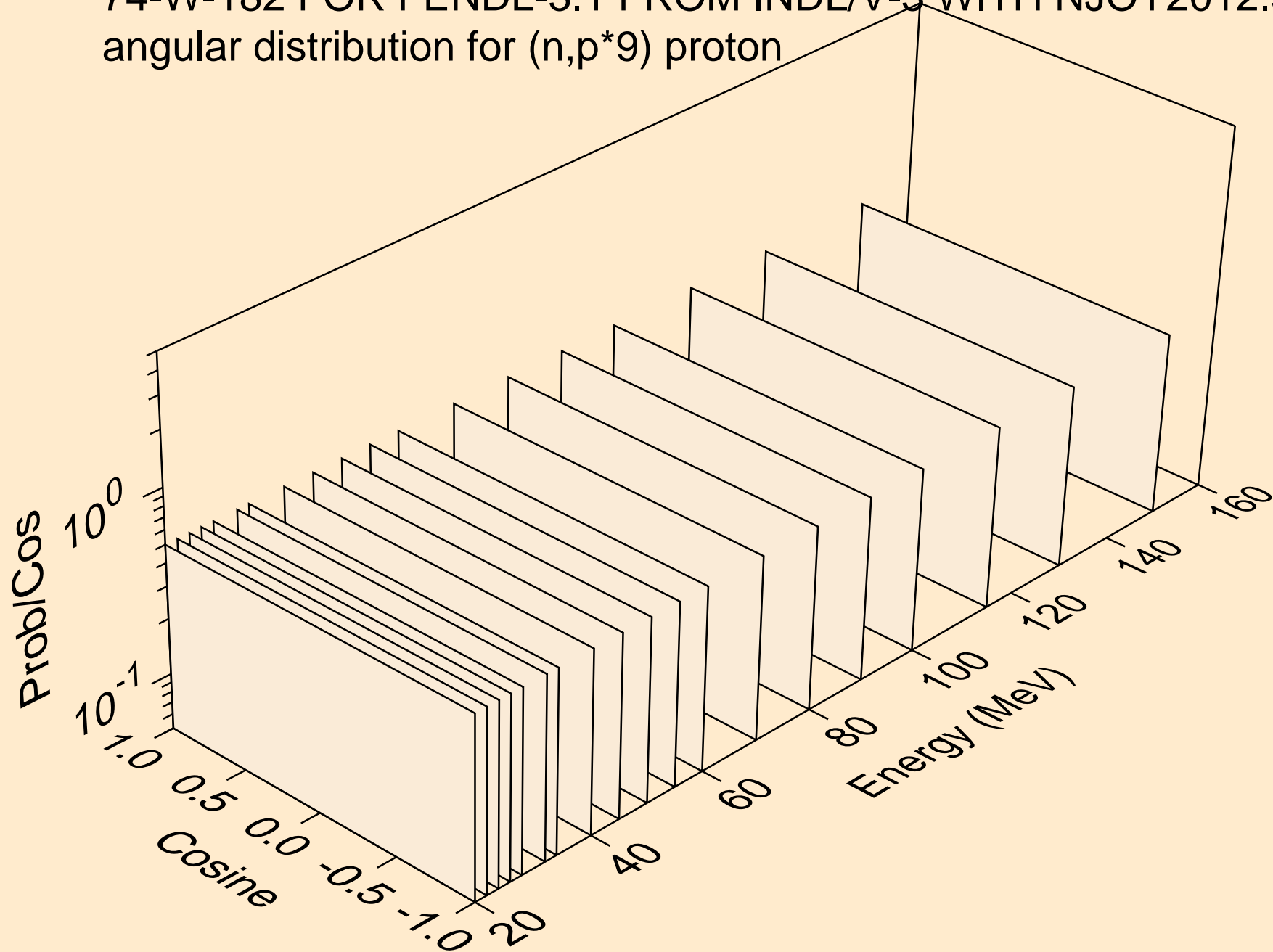

74-W-182 FOR FENDL-3.1 FROM INDL/V-3 WITH NJOY2012.50+ C
angular distribution for (n,p*10) proton

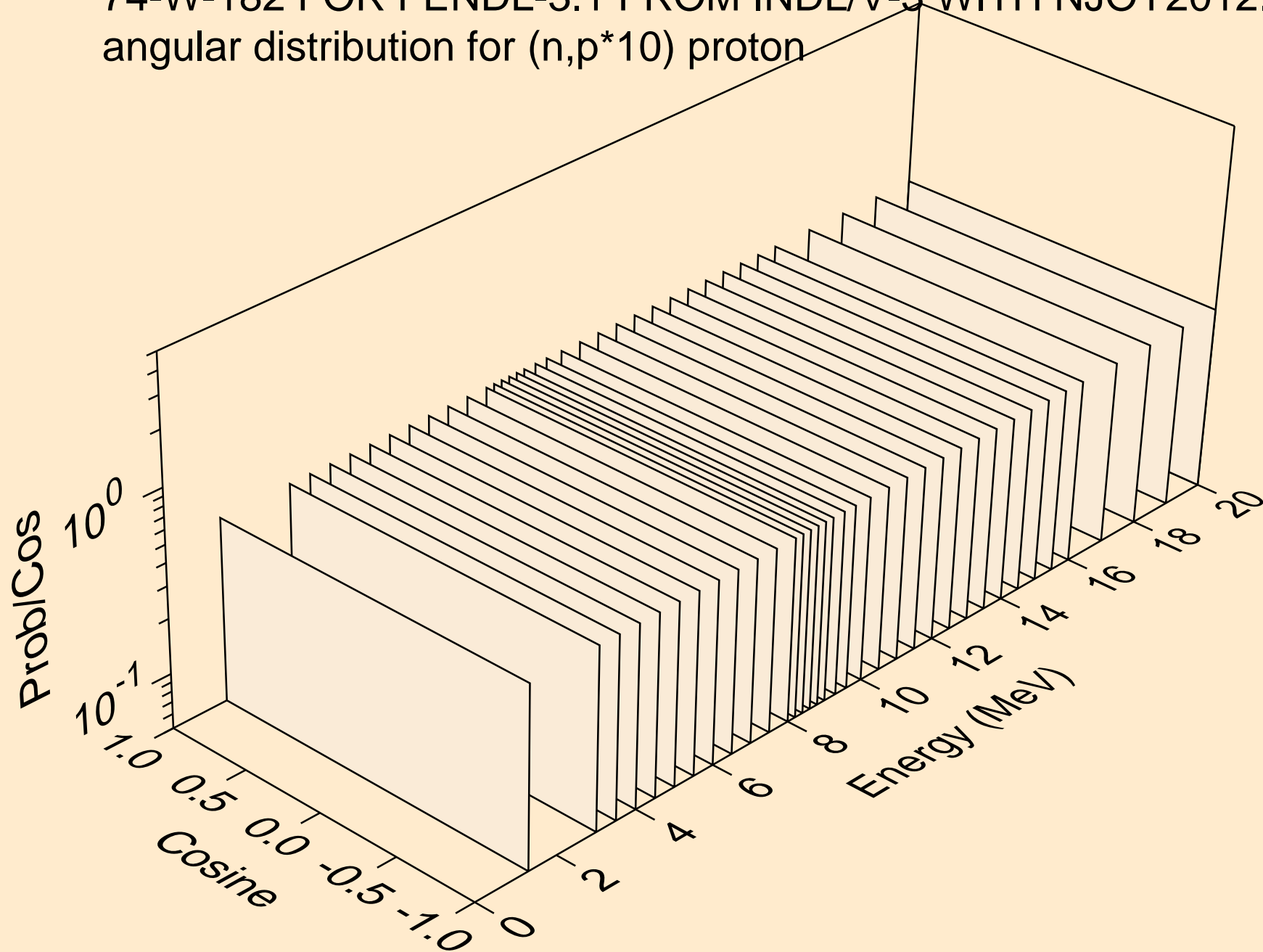

74-W-182 FOR FENDL-3.1 FROM INDL/V-3 WITH NJOY2012.50+ C
angular distribution for (n,p*10) proton

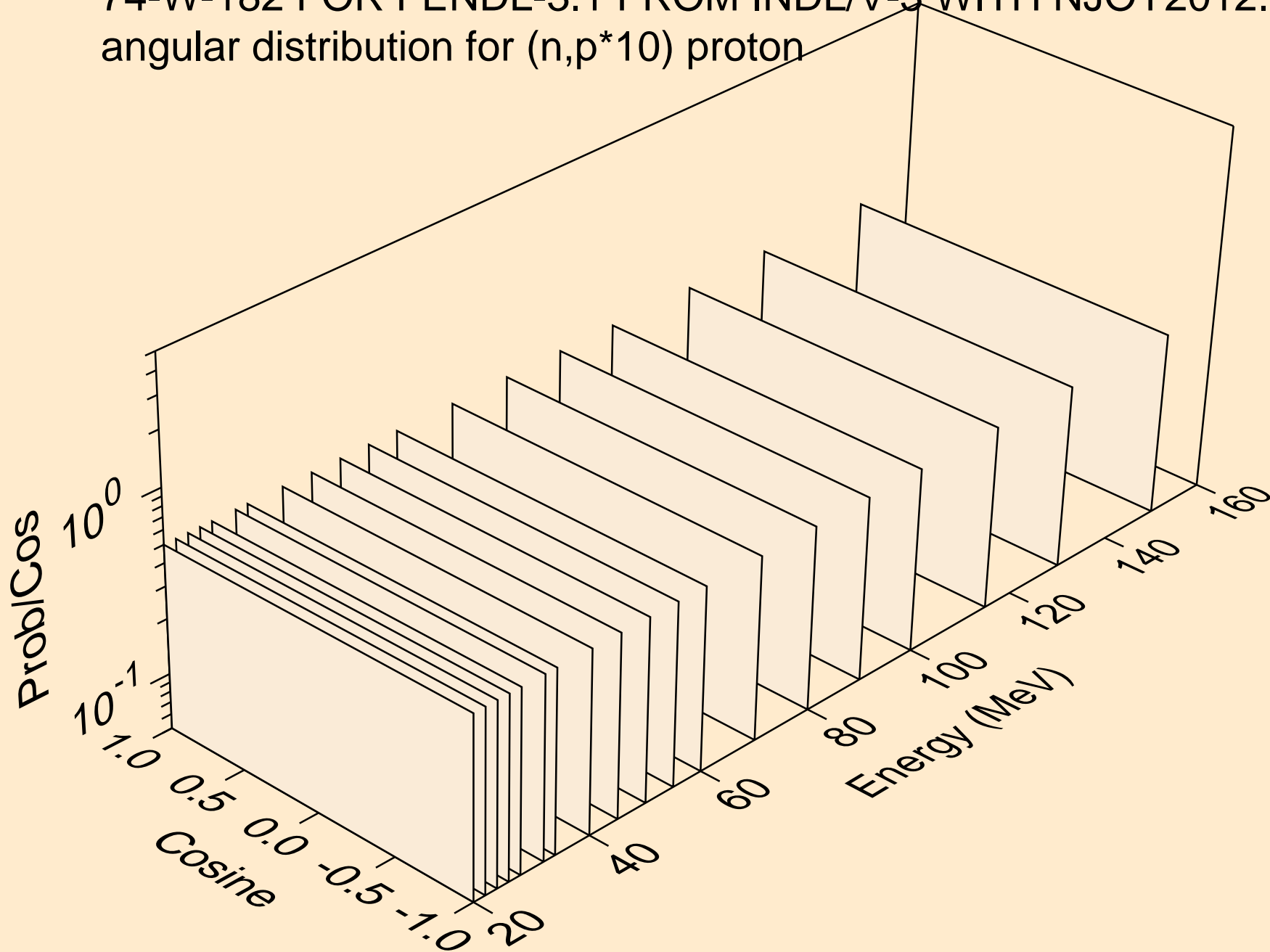

74-W-182 FOR FENDL-3.1 FROM INDL/V-3 WITH NJOY2012.50+ C
angular distribution for (n,p*11) proton

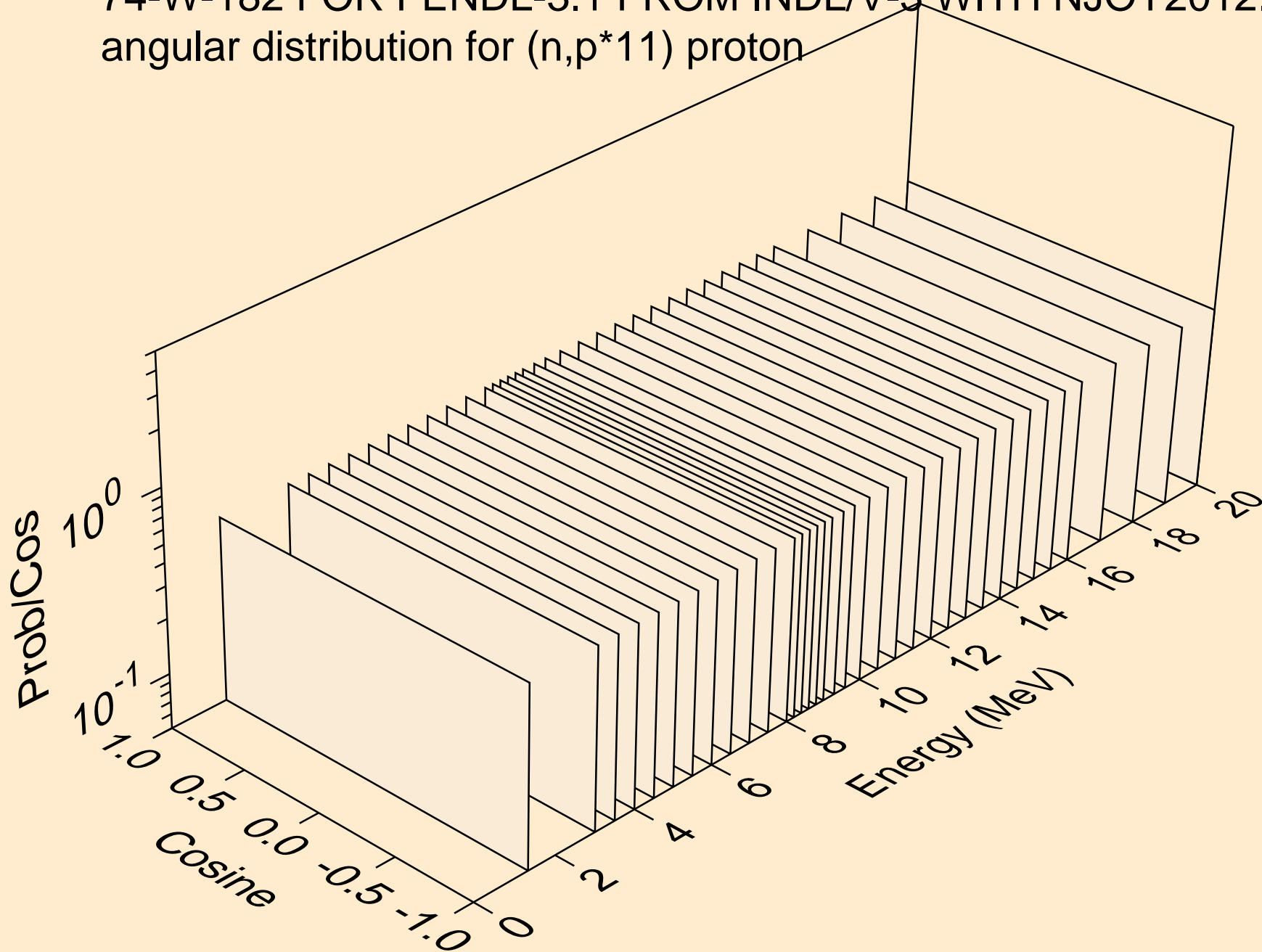

74-W-182 FOR FENDL-3.1 FROM INDL/V-3 WITH NJOY2012.50+ C
angular distribution for (n,p*11) proton

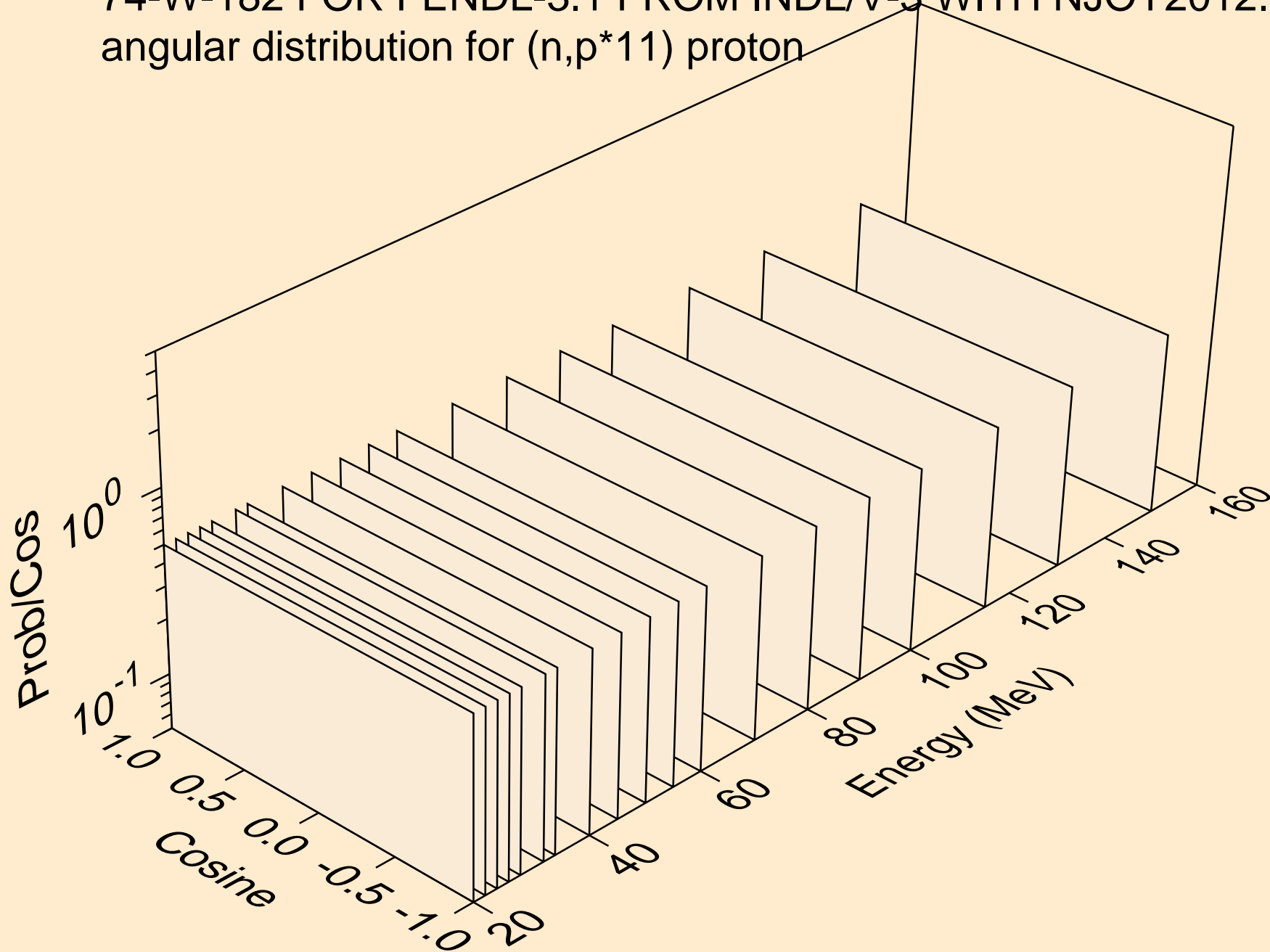

74-W-182 FOR FENDL-3.1 FROM INDL/V-3 WITH NJOY2012.50+ C
angular distribution for (n,p*12) proton

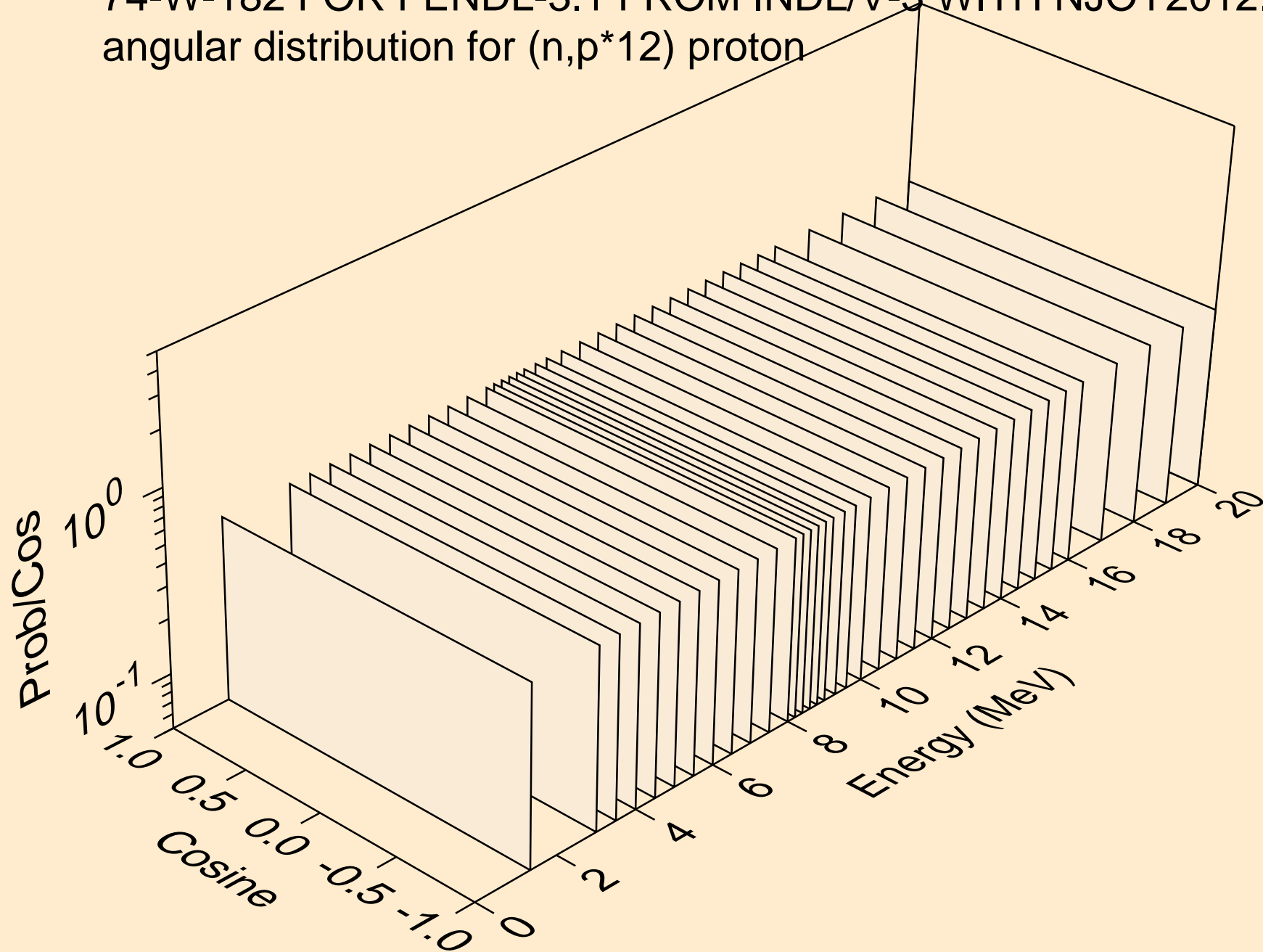

74-W-182 FOR FENDL-3.1 FROM INDL/V-3 WITH NJOY2012.50+ C
angular distribution for (n,p*12) proton

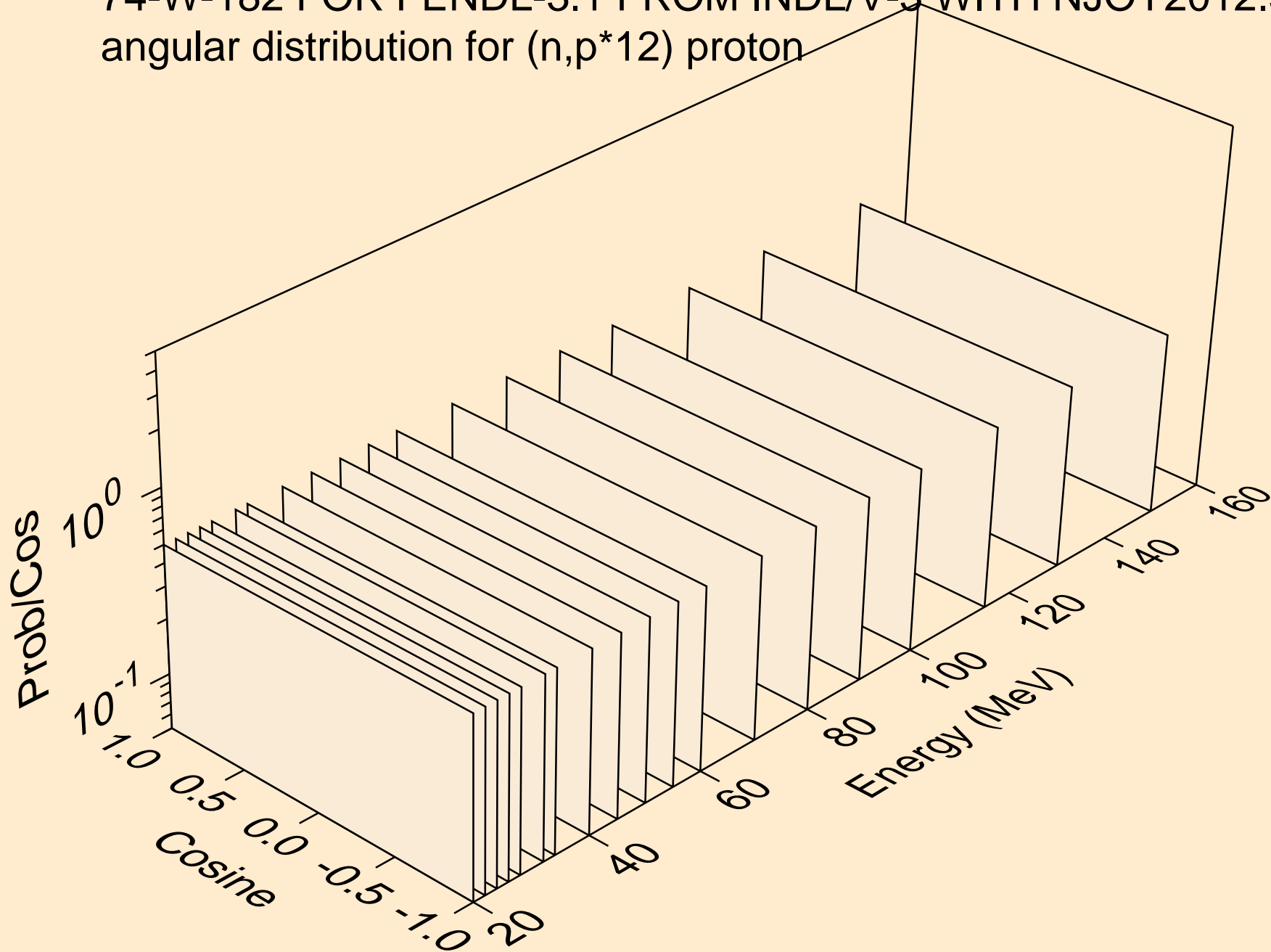

74-W-182 FOR FENDL-3.1 FROM INDL/V-3 WITH NJOY2012.50+ C
angular distribution for (n,p*13) proton

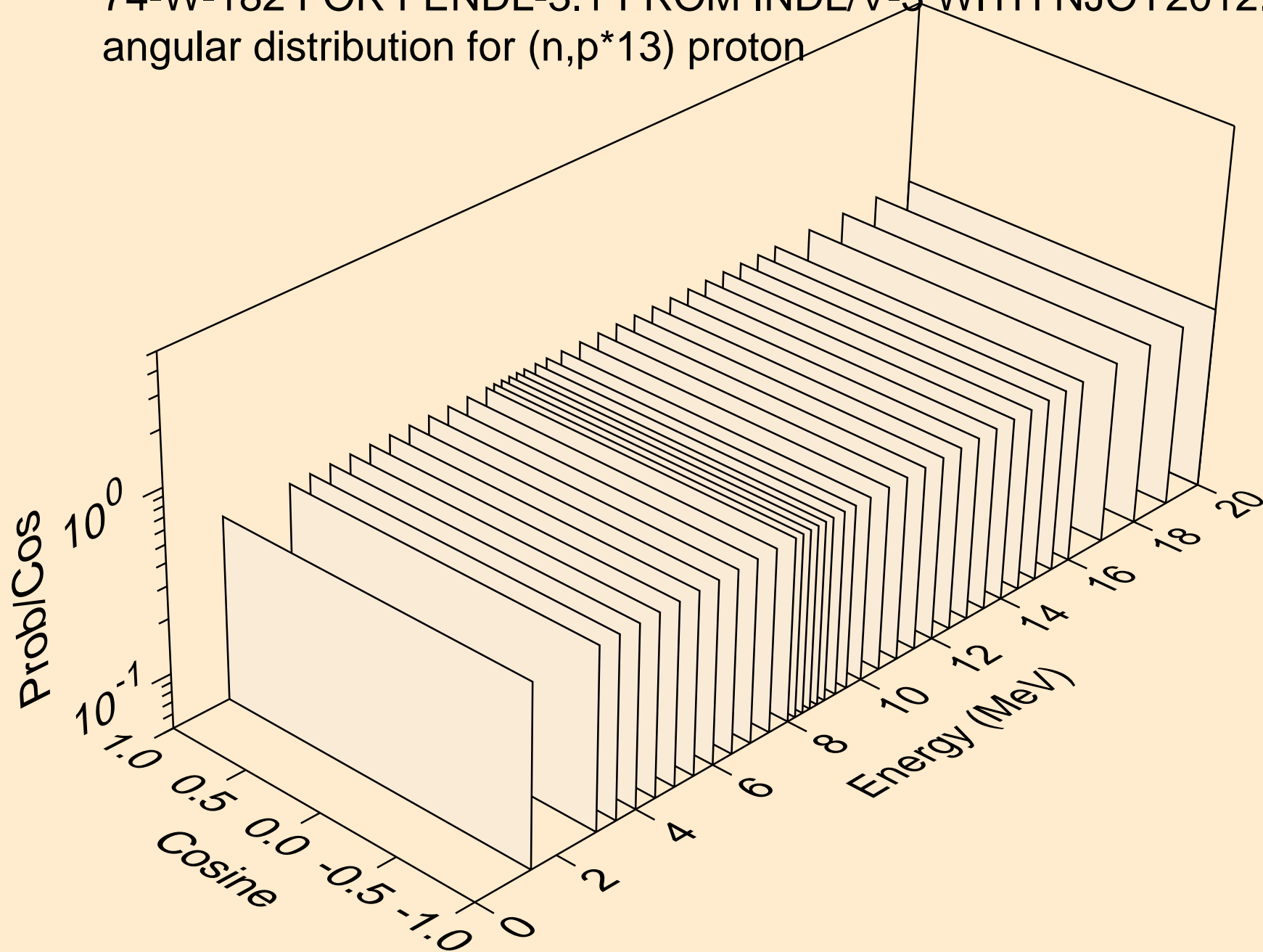

74-W-182 FOR FENDL-3.1 FROM INDL/V-3 WITH NJOY2012.50+ C
angular distribution for (n,p*13) proton

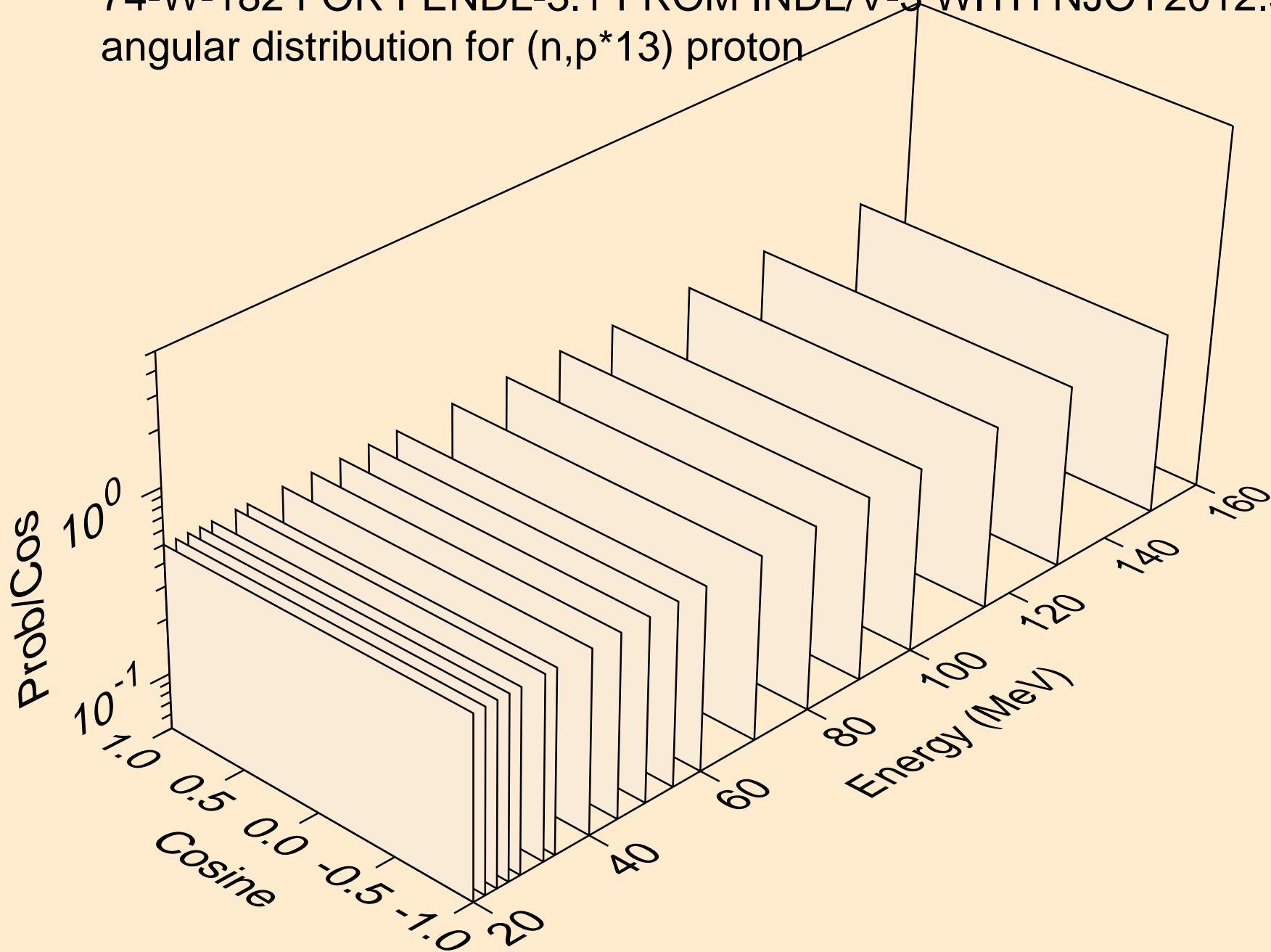

74-W-182 FOR FENDL-3.1 FROM INDL/V-3 WITH NJOY2012.50+ C
angular distribution for (n,p*14) proton

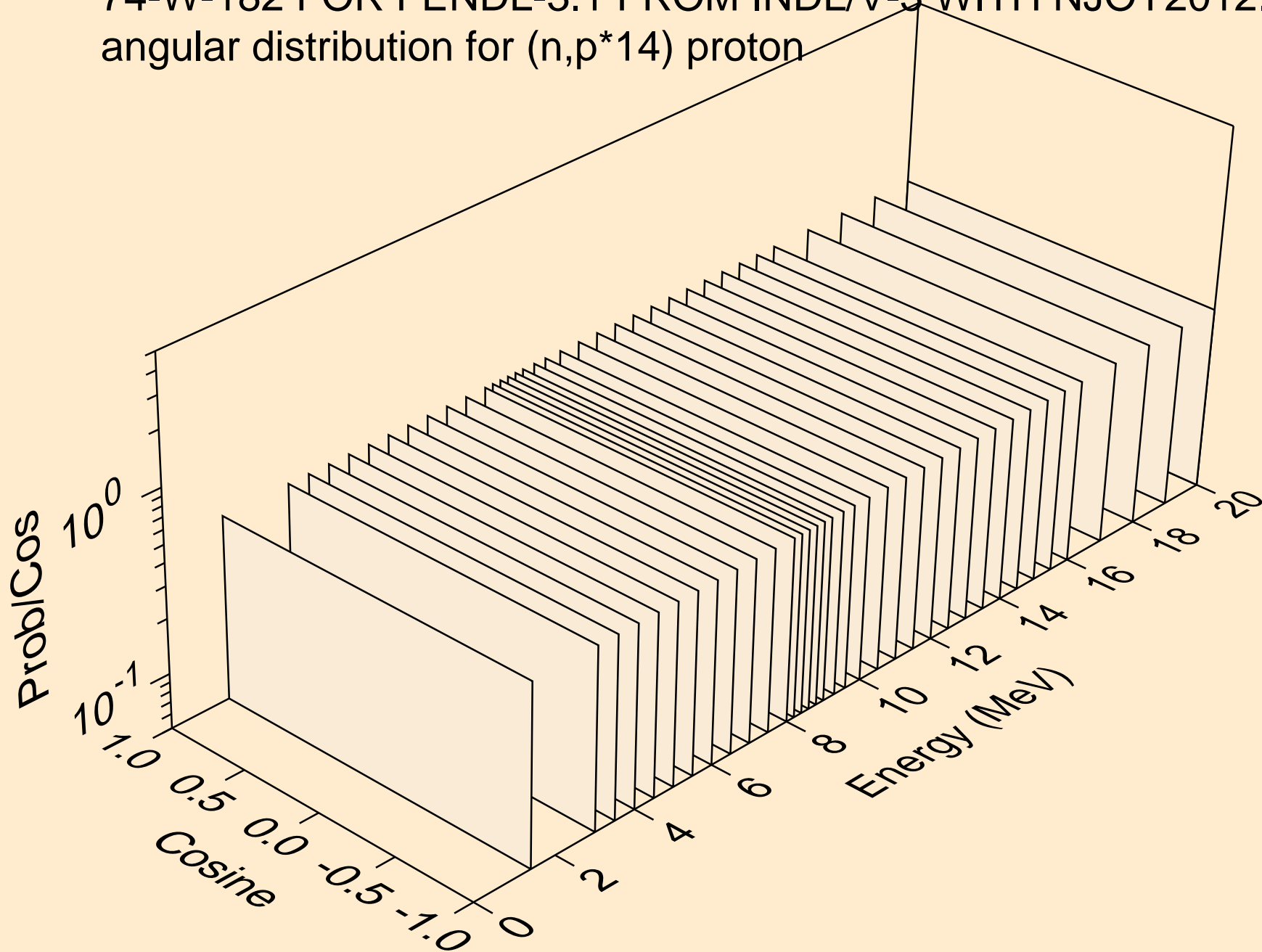

74-W-182 FOR FENDL-3.1 FROM INDL/V-3 WITH NJOY2012.50+ C
angular distribution for (n,p*14) proton

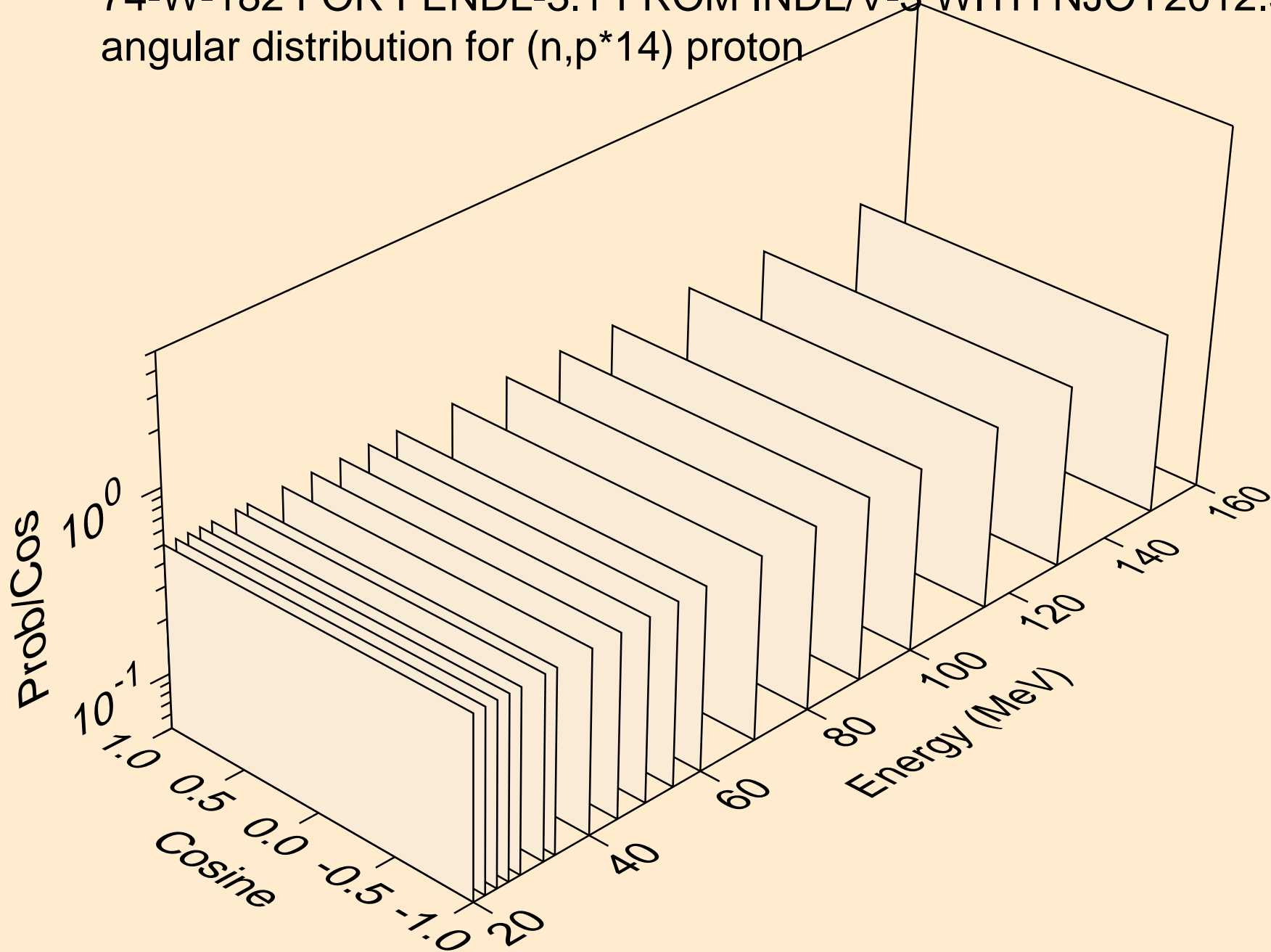

74-W-182 FOR FENDL-3.1 FROM INDL/V-3 WITH NJOY2012.50+ C
angular distribution for (n,p*15) proton

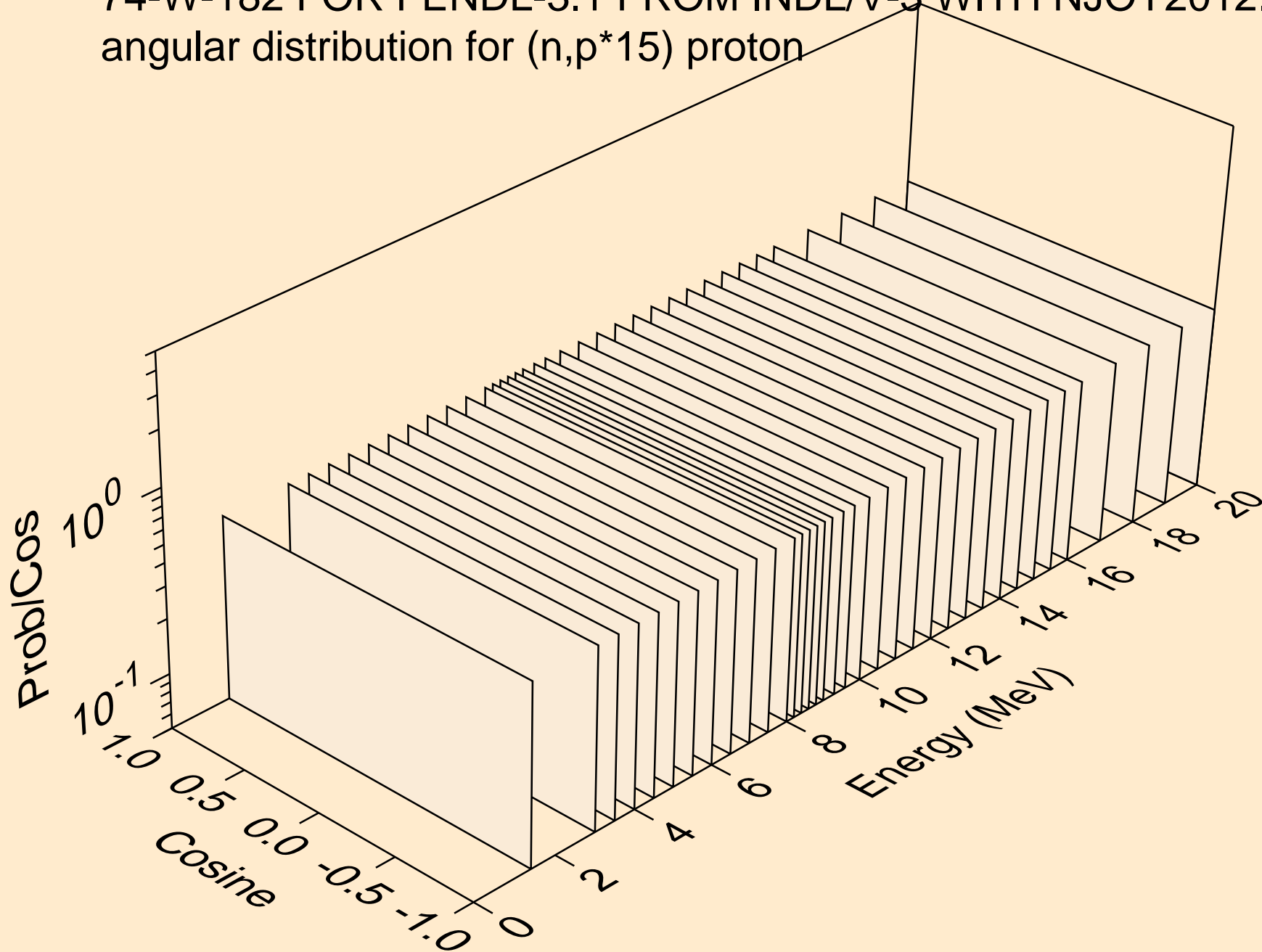

74-W-182 FOR FENDL-3.1 FROM INDL/V-3 WITH NJOY2012.50+ C
angular distribution for (n,p*15) proton

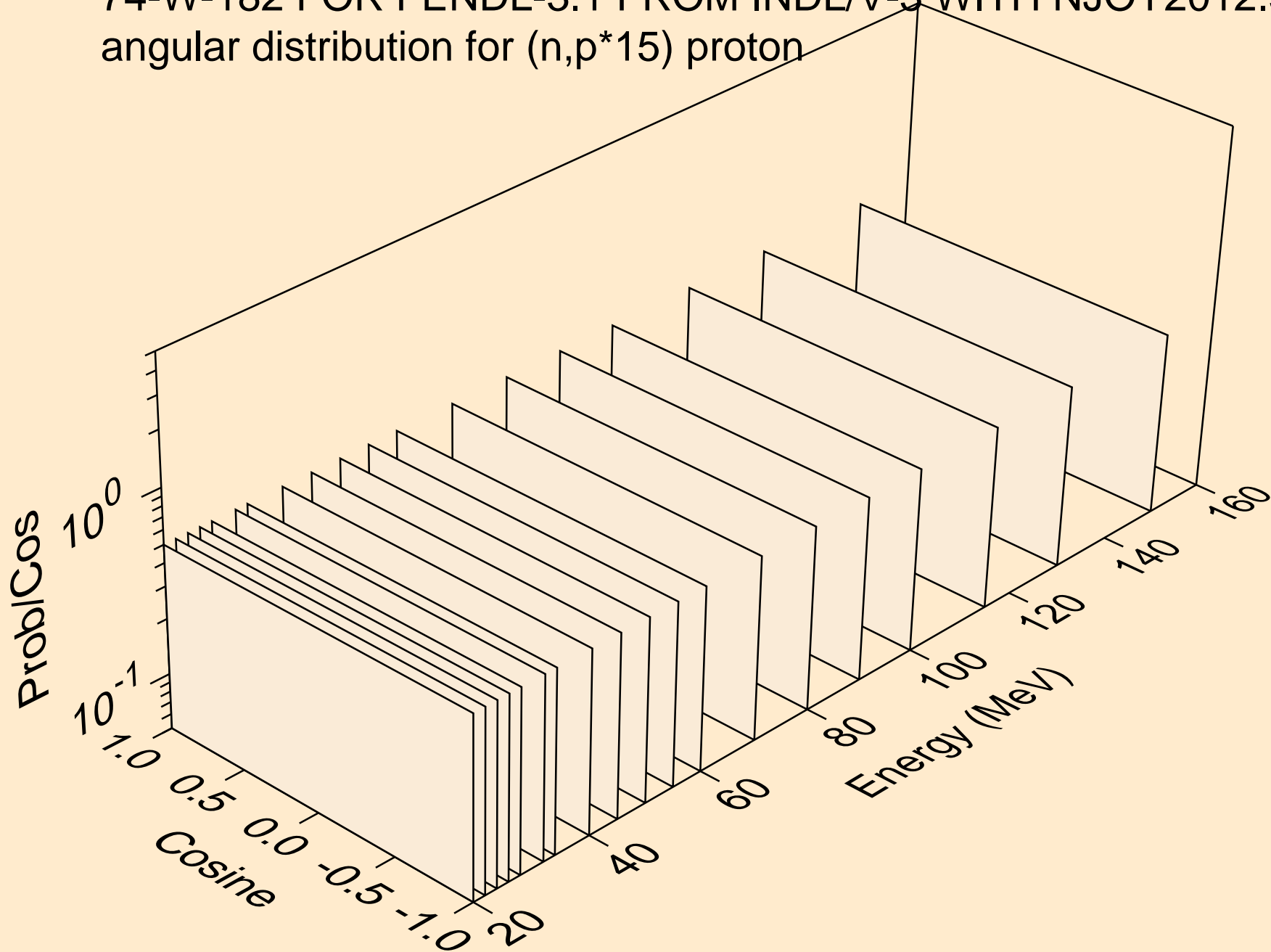

74-W-182 FOR FENDL-3.1 FROM INDL/V-3 WITH NJOY2012.50+ C
angular distribution for (n,p*16) proton

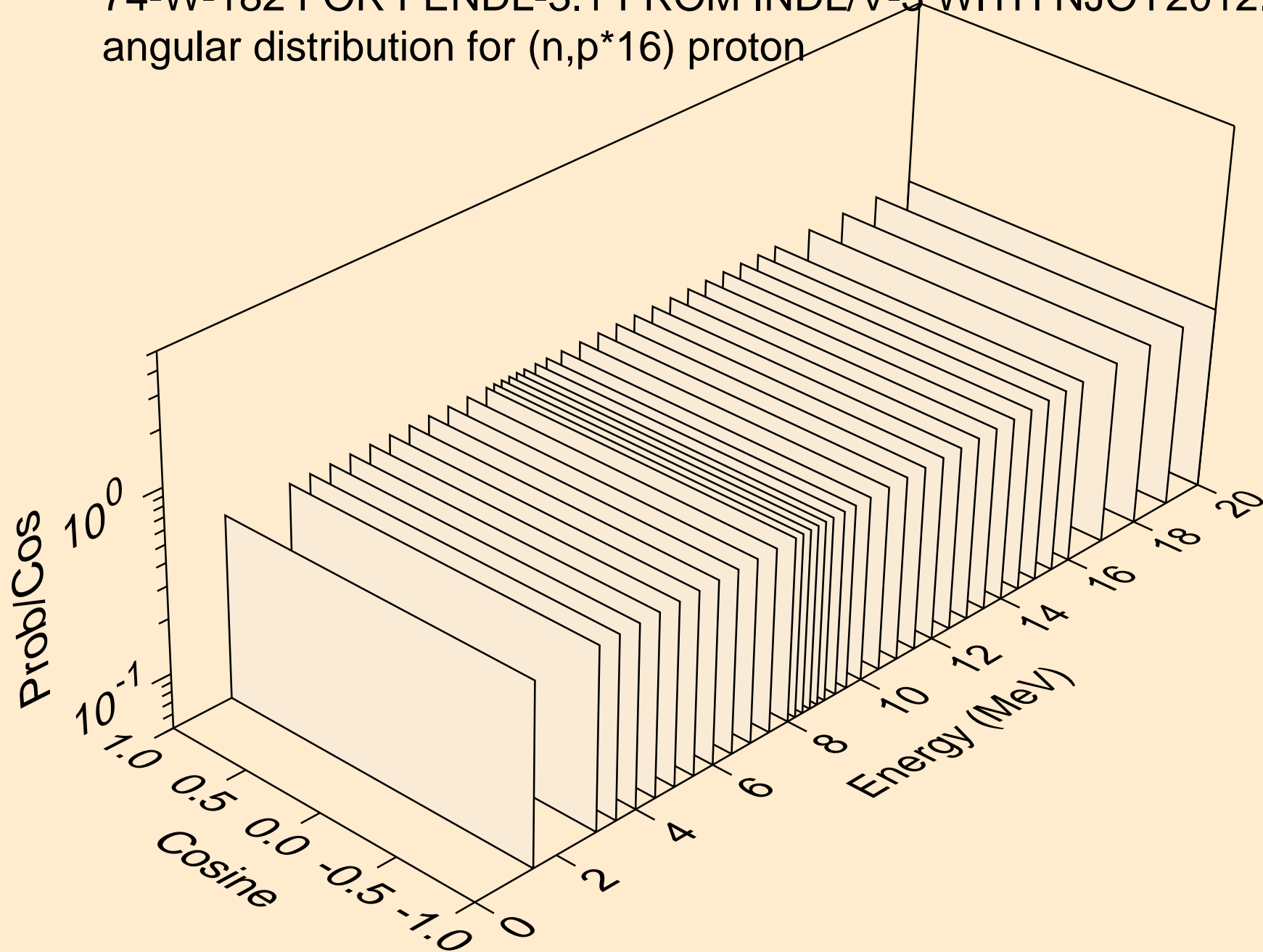

74-W-182 FOR FENDL-3.1 FROM INDL/V-3 WITH NJOY2012.50+ C
angular distribution for (n,p*16) proton

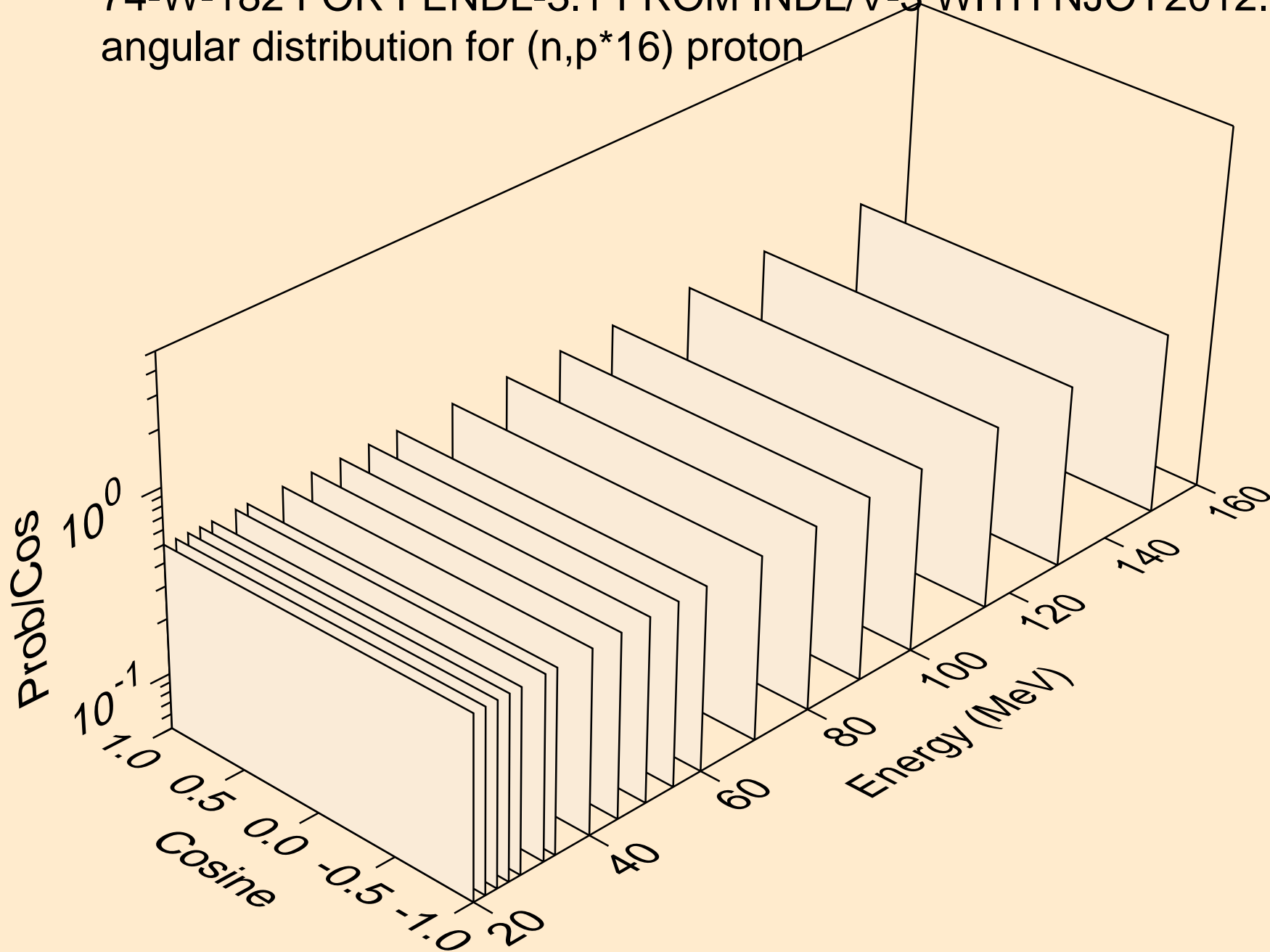

74-W-182 FOR FENDL-3.1 FROM INDL/V-3 WITH NJOY2012.50+ C
angular distribution for (n,p*17) proton

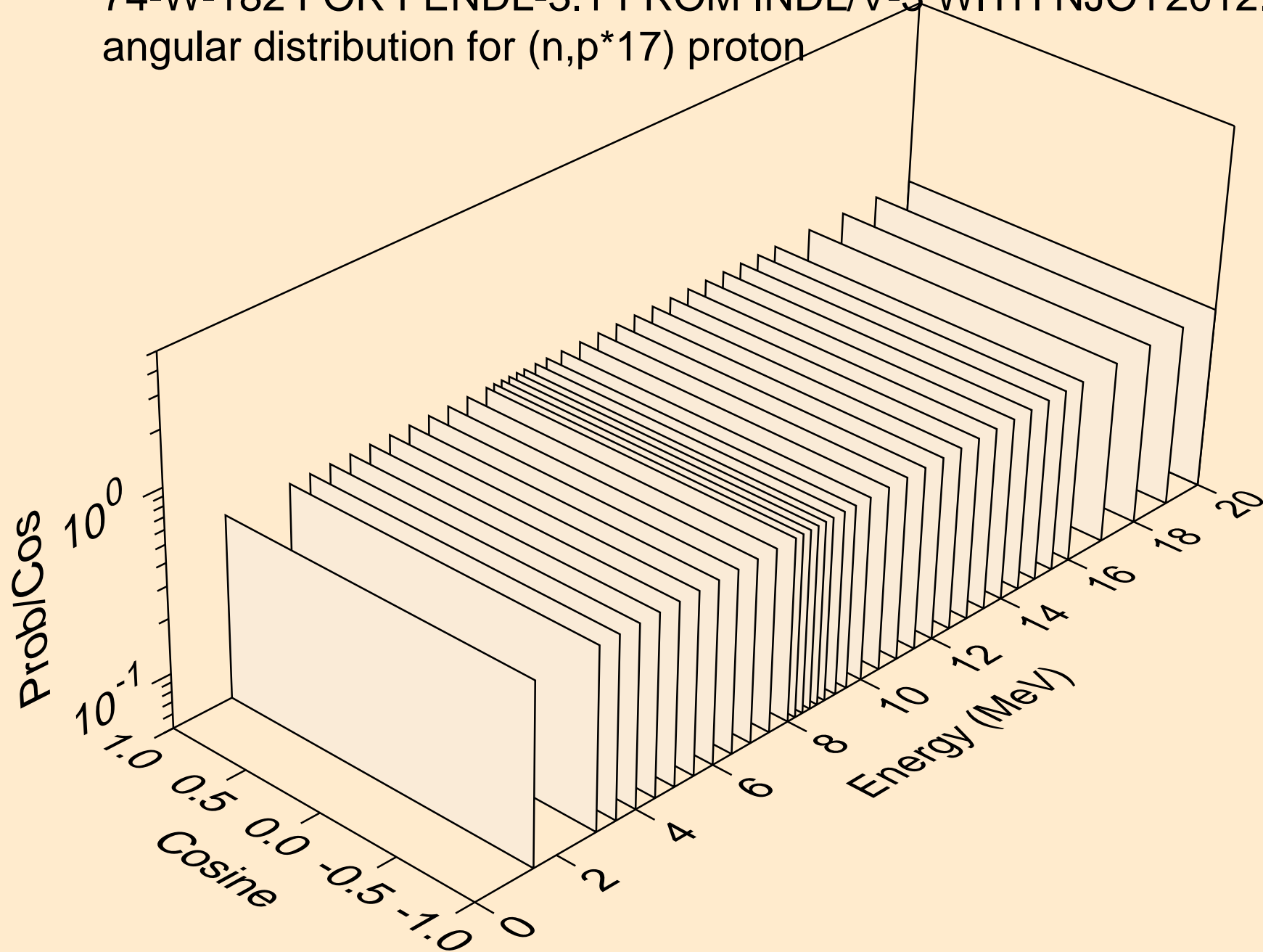

74-W-182 FOR FENDL-3.1 FROM INDL/V-3 WITH NJOY2012.50+ C
angular distribution for (n,p*17) proton

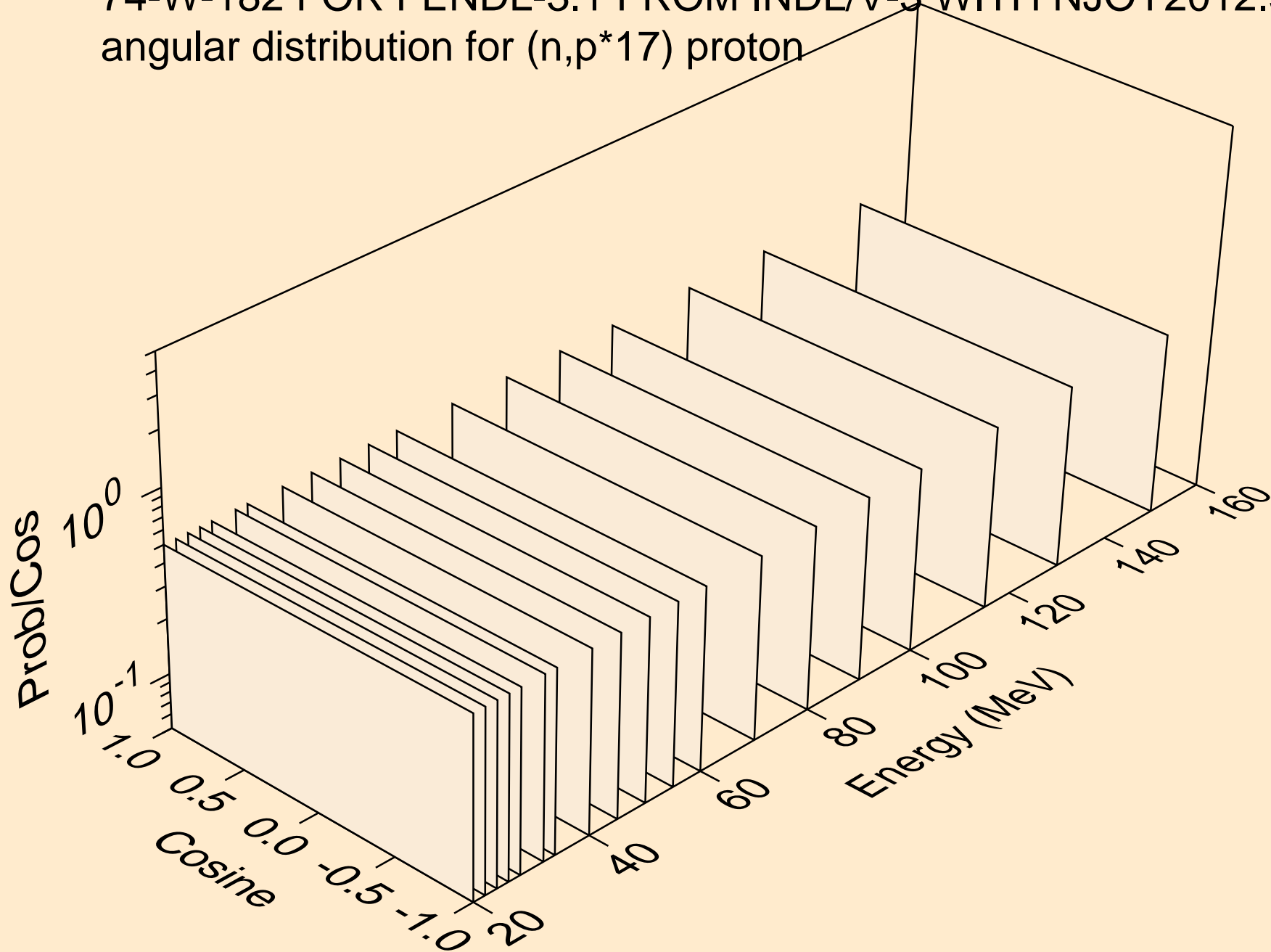

74-W-182 FOR FENDL-3.1 FROM INDL/V-3 WITH NJOY2012.50+ C
angular distribution for (n,p*18) proton

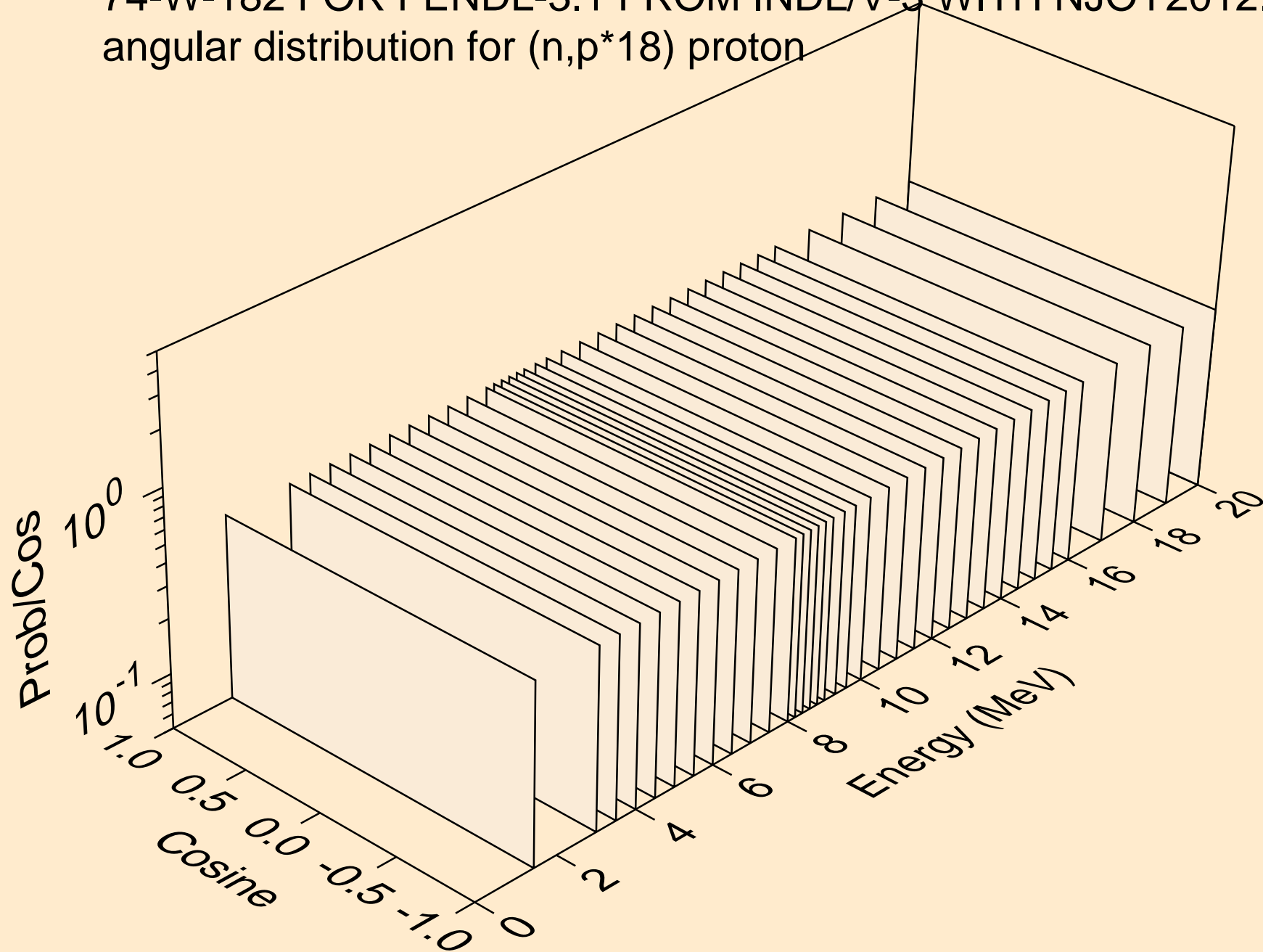

74-W-182 FOR FENDL-3.1 FROM INDL/V-3 WITH NJOY2012.50+ C
angular distribution for (n,p*18) proton

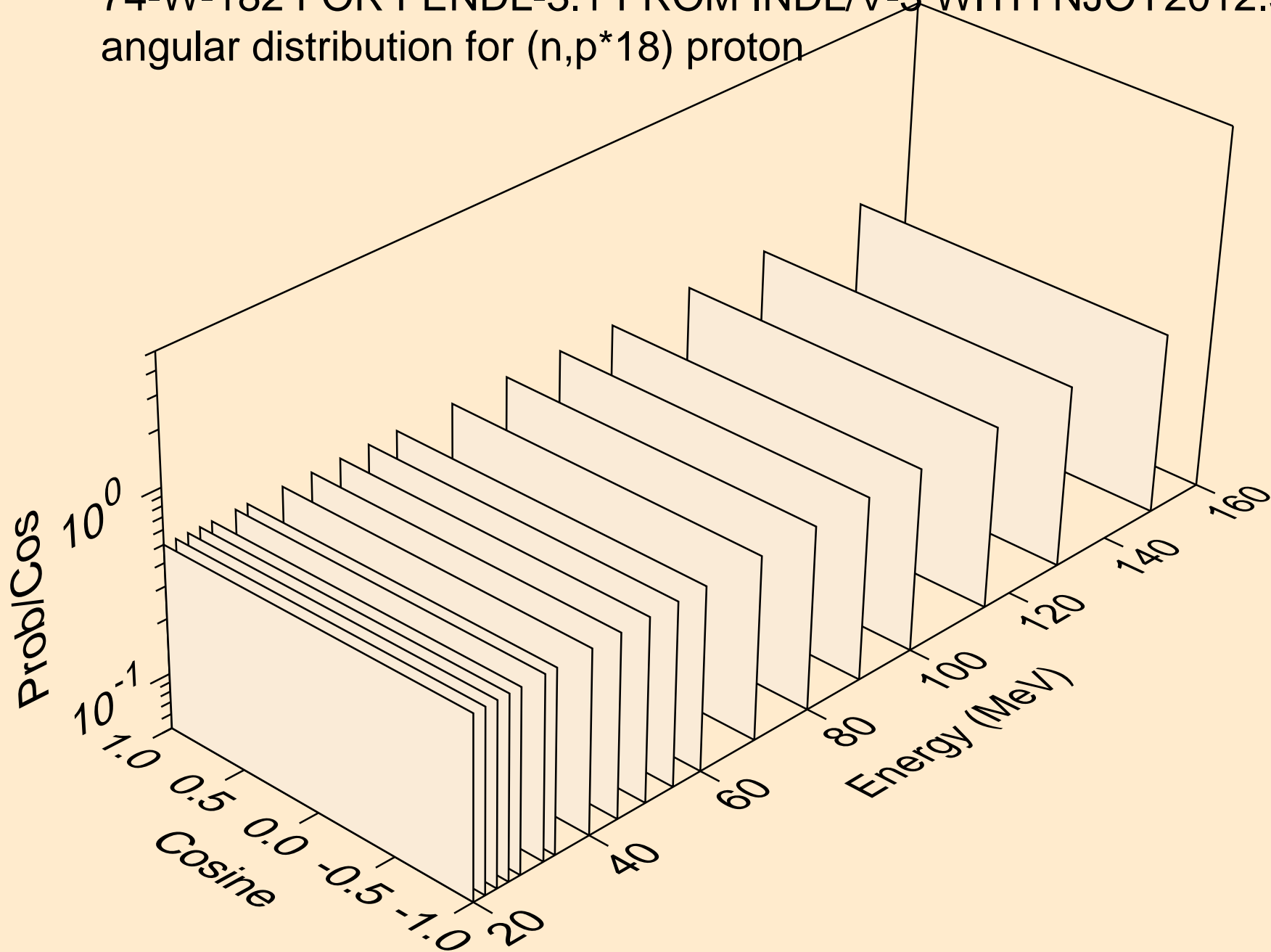

74-W-182 FOR FENDL-3.1 FROM INDL/V-3 WITH NJOY2012.50+ C
angular distribution for (n,p*19) proton

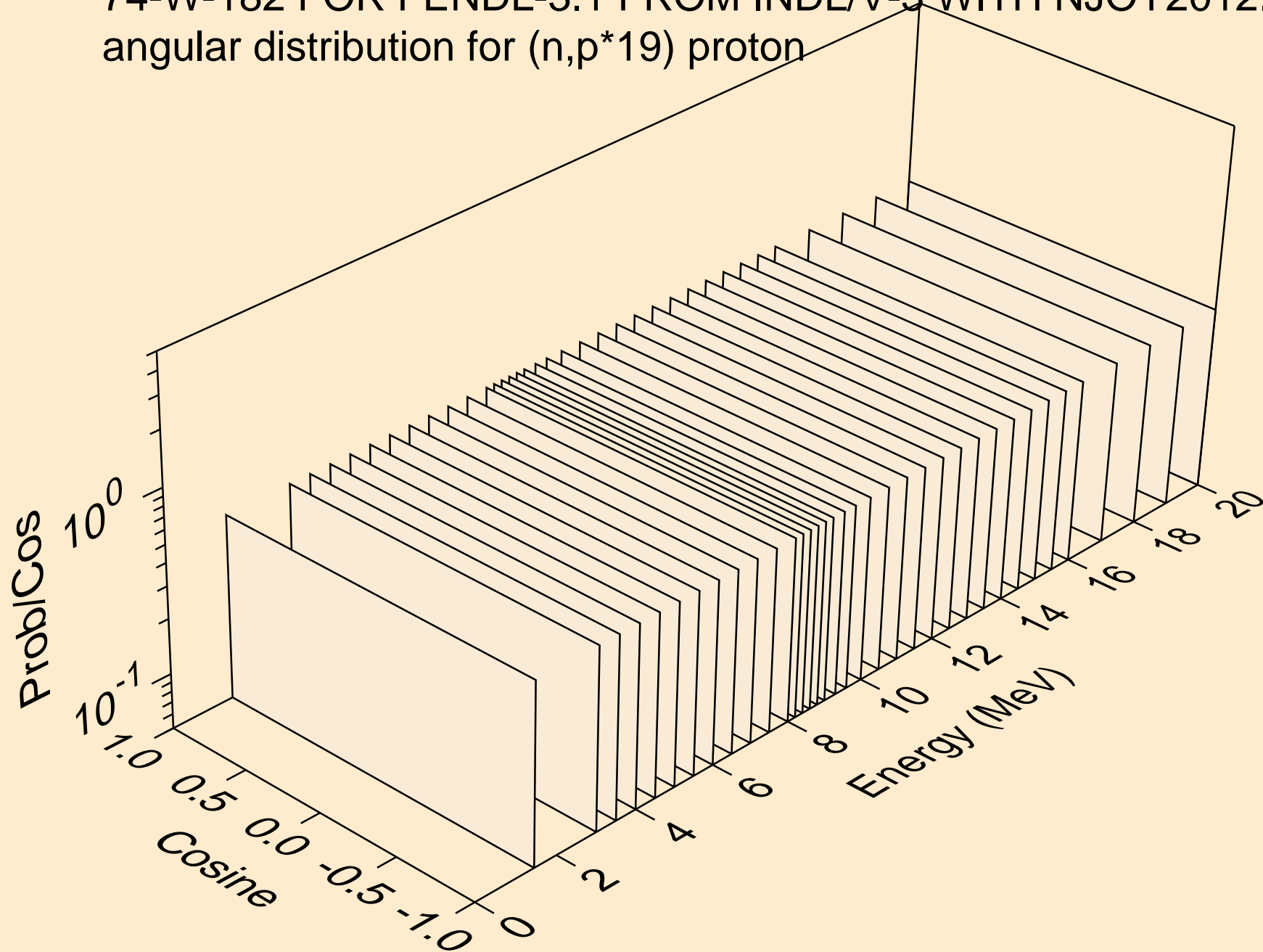

74-W-182 FOR FENDL-3.1 FROM INDL/V-3 WITH NJOY2012.50+ C
angular distribution for (n,p*19) proton

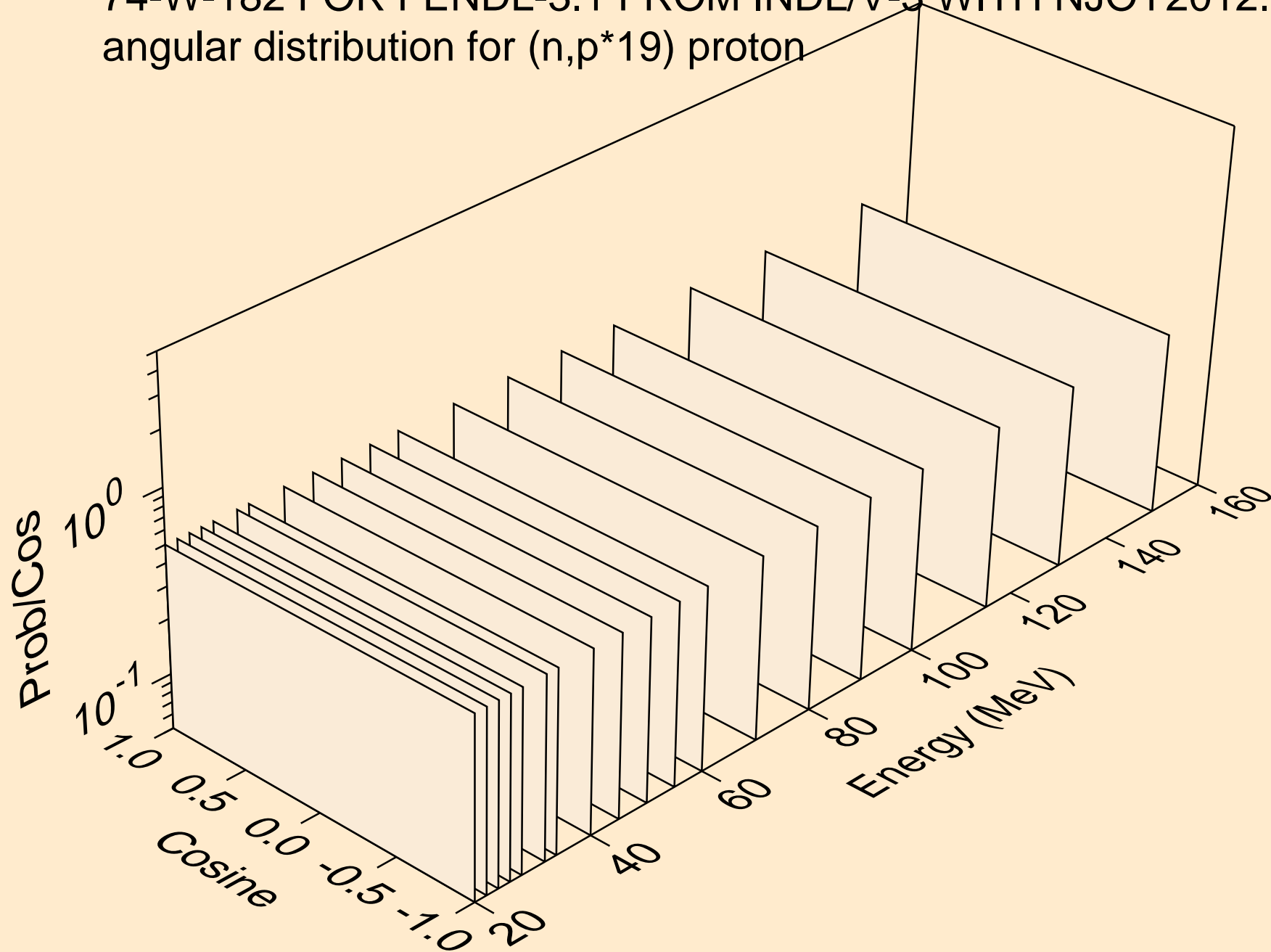

74-W-182 FOR FENDL-3.1 FROM INDL/V-3 WITH NJOY2012.50+ C
angular distribution for (n,p*20) proton

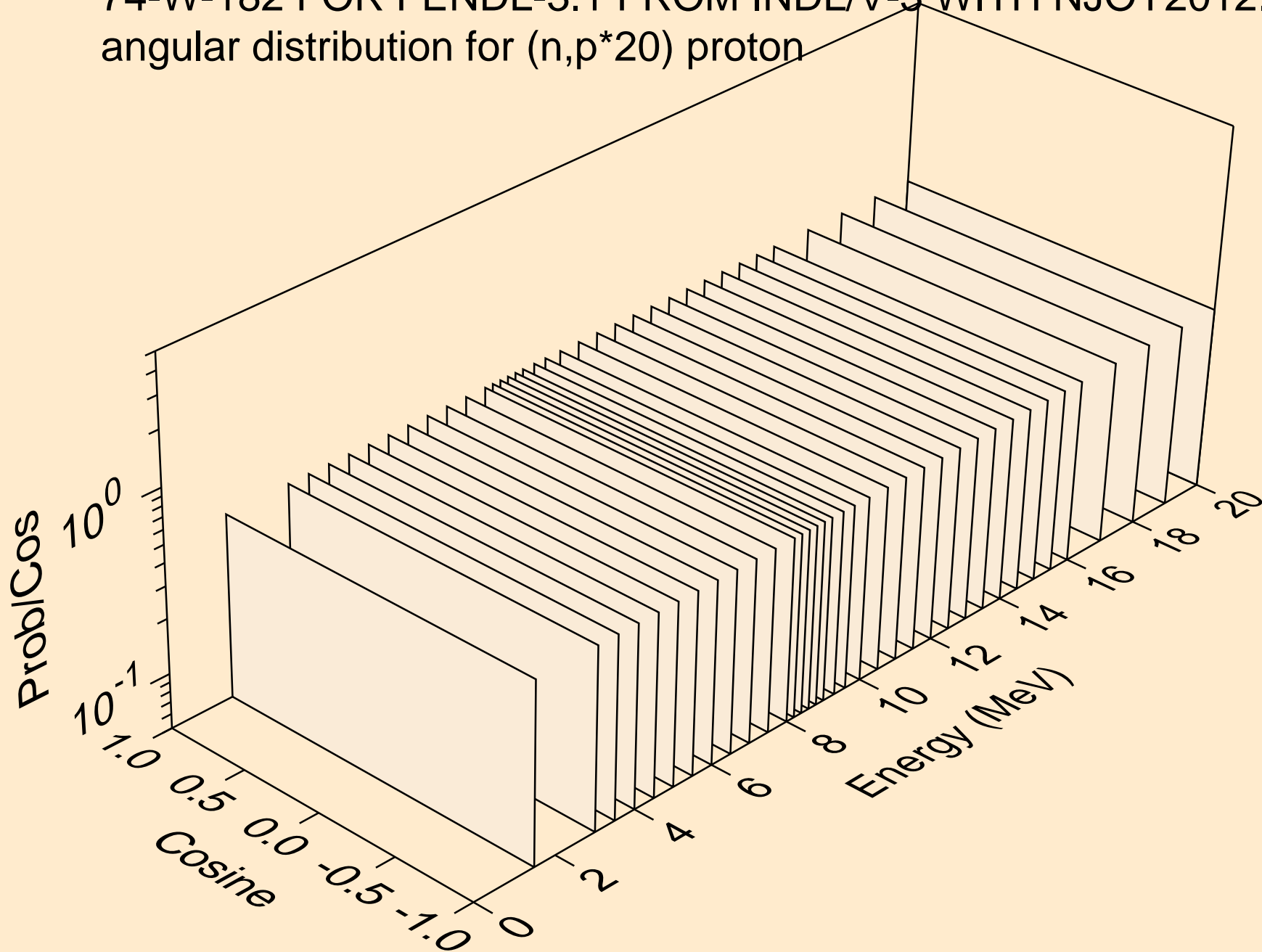

74-W-182 FOR FENDL-3.1 FROM INDL/V-3 WITH NJOY2012.50+ C
angular distribution for (n,p*20) proton

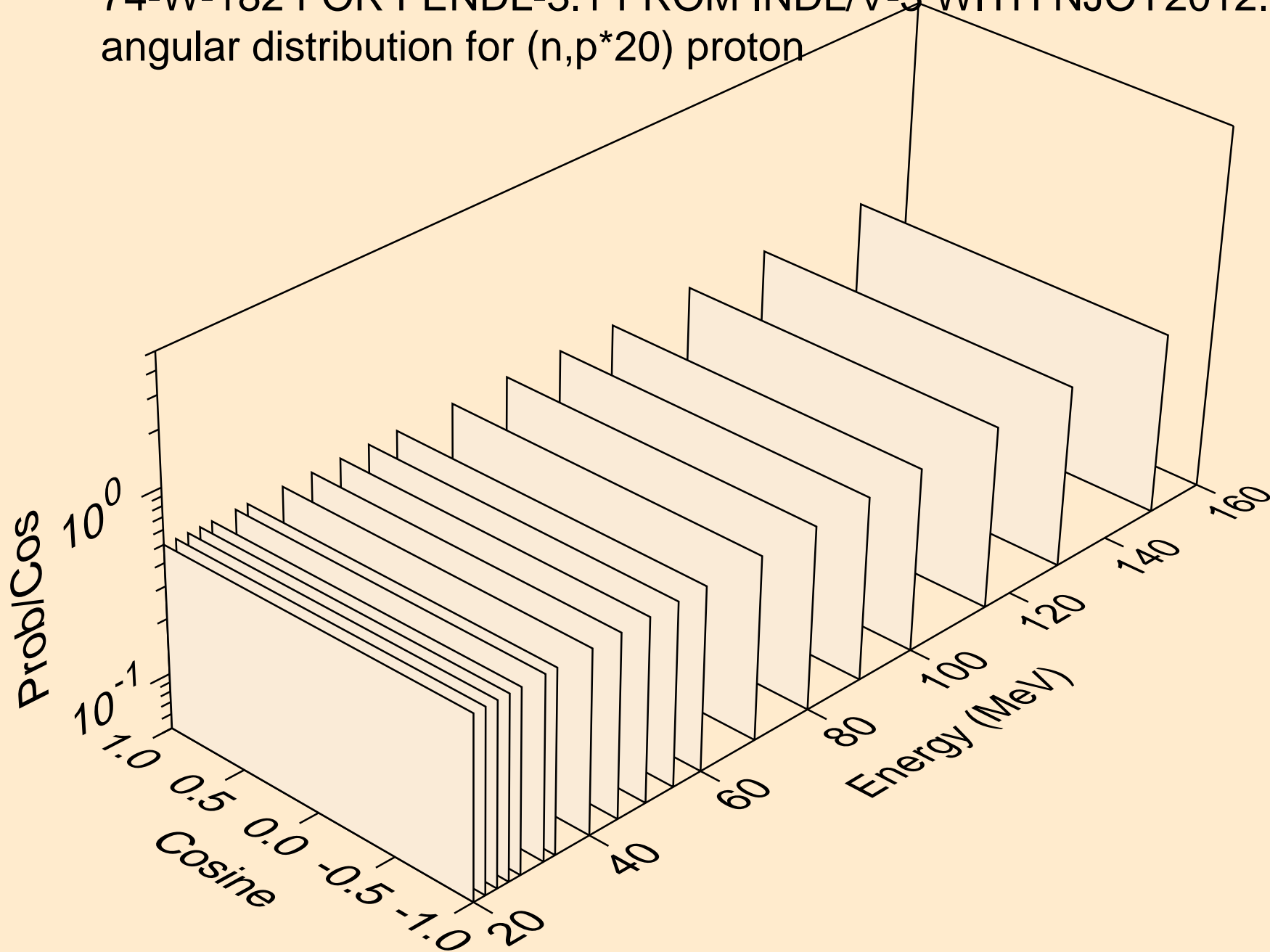

74-W-182 FOR FENDL-3.1 FROM INDL/V-3 WITH NJOY2012.50+ C
angular distribution for (n,p*21) proton

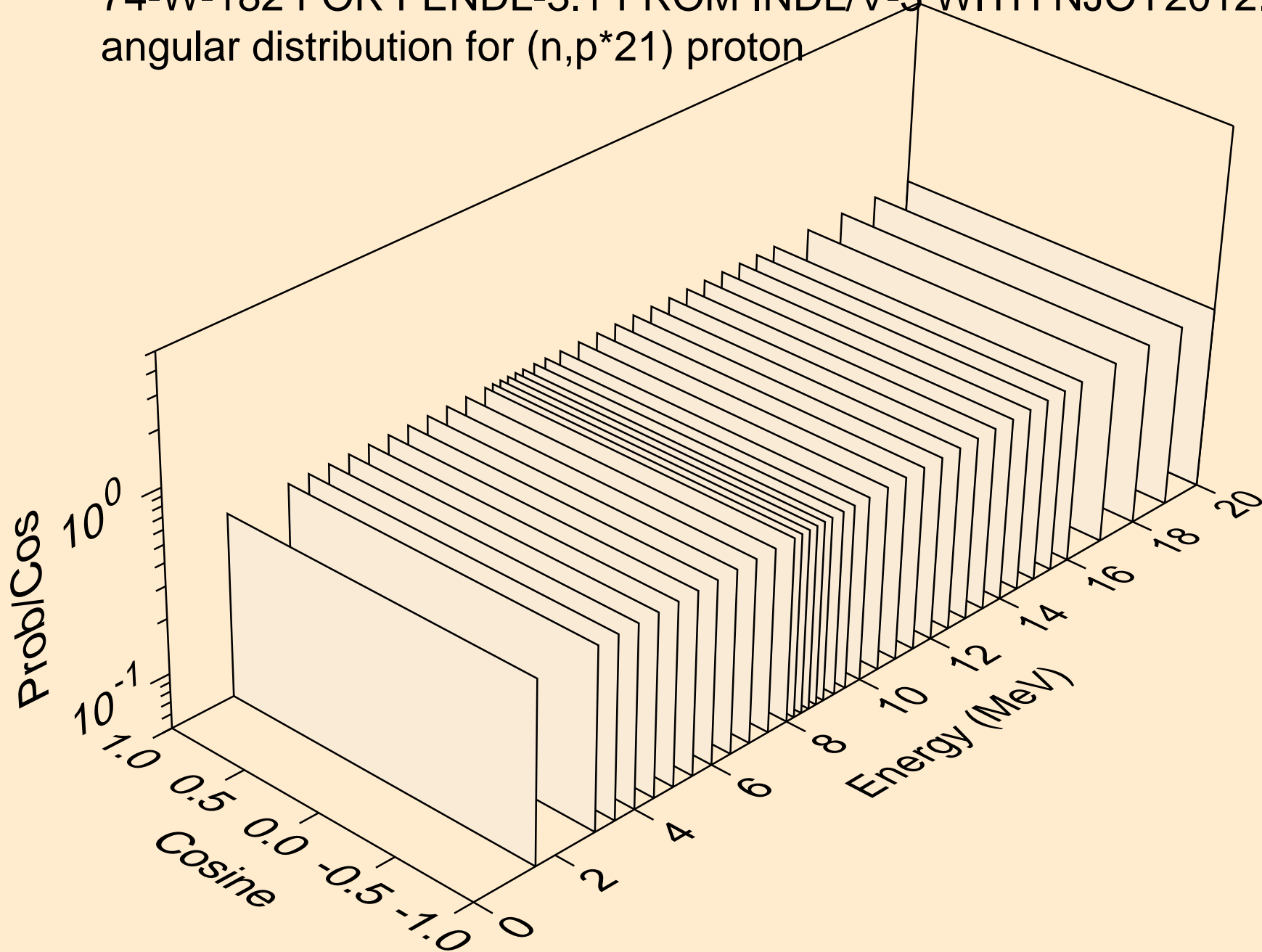

74-W-182 FOR FENDL-3.1 FROM INDL/V-3 WITH NJOY2012.50+ C
angular distribution for (n,p*21) proton

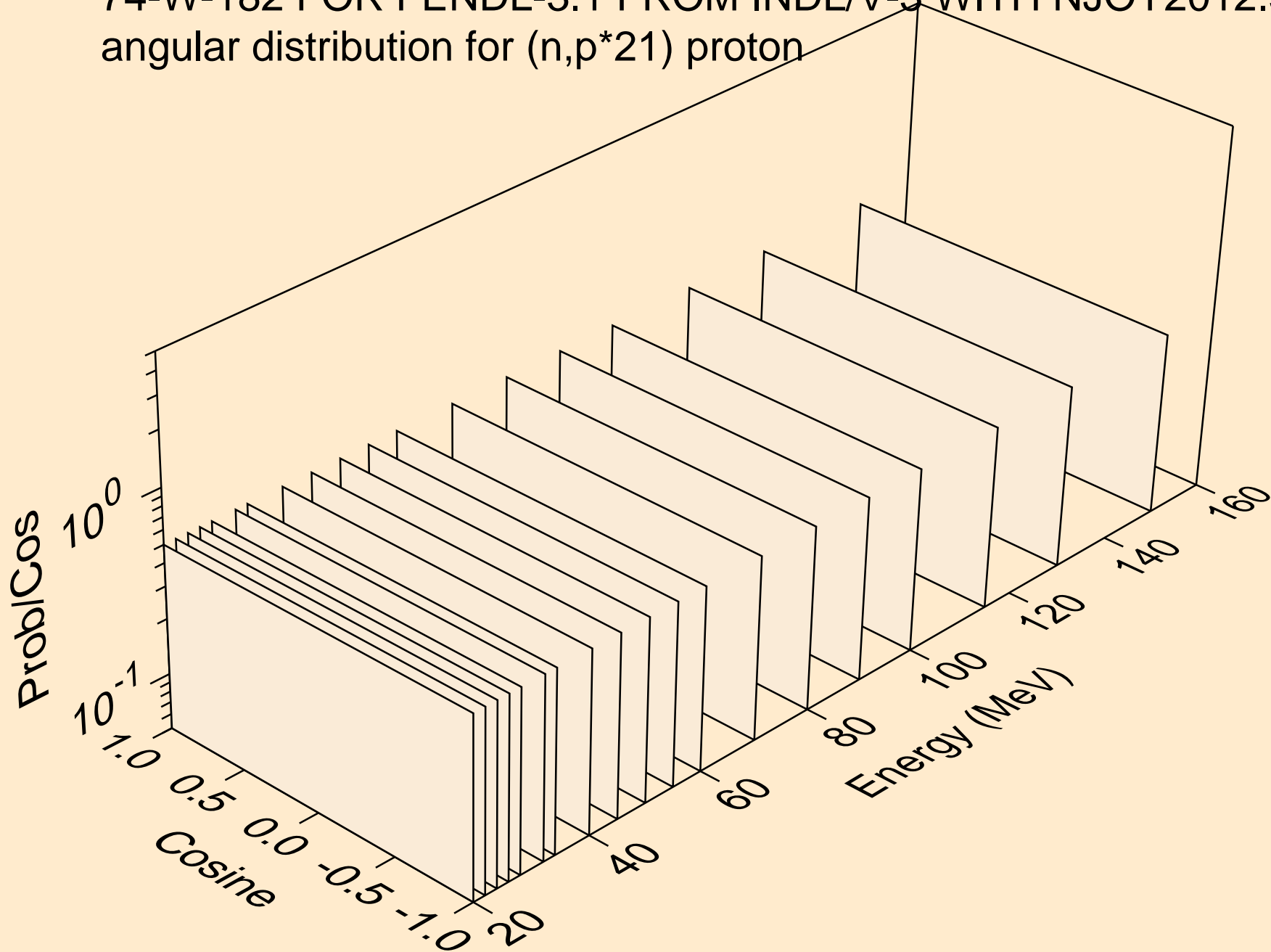

74-W-182 FOR FENDL-3.1 FROM INDL/V-3 WITH NJOY2012.50+ C
angular distribution for (n,p*22) proton

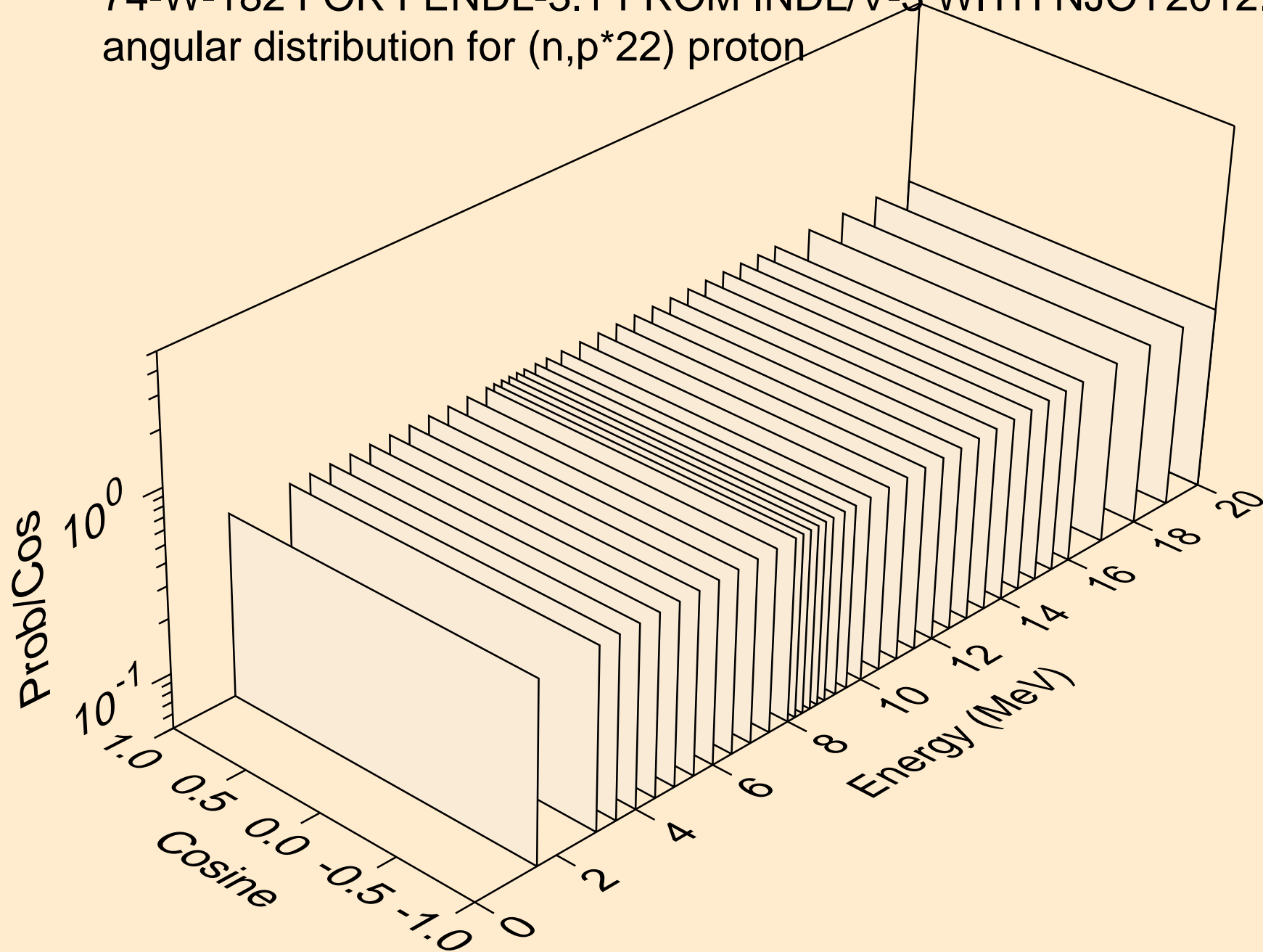

74-W-182 FOR FENDL-3.1 FROM INDL/V-3 WITH NJOY2012.50+ C
angular distribution for (n,p*22) proton

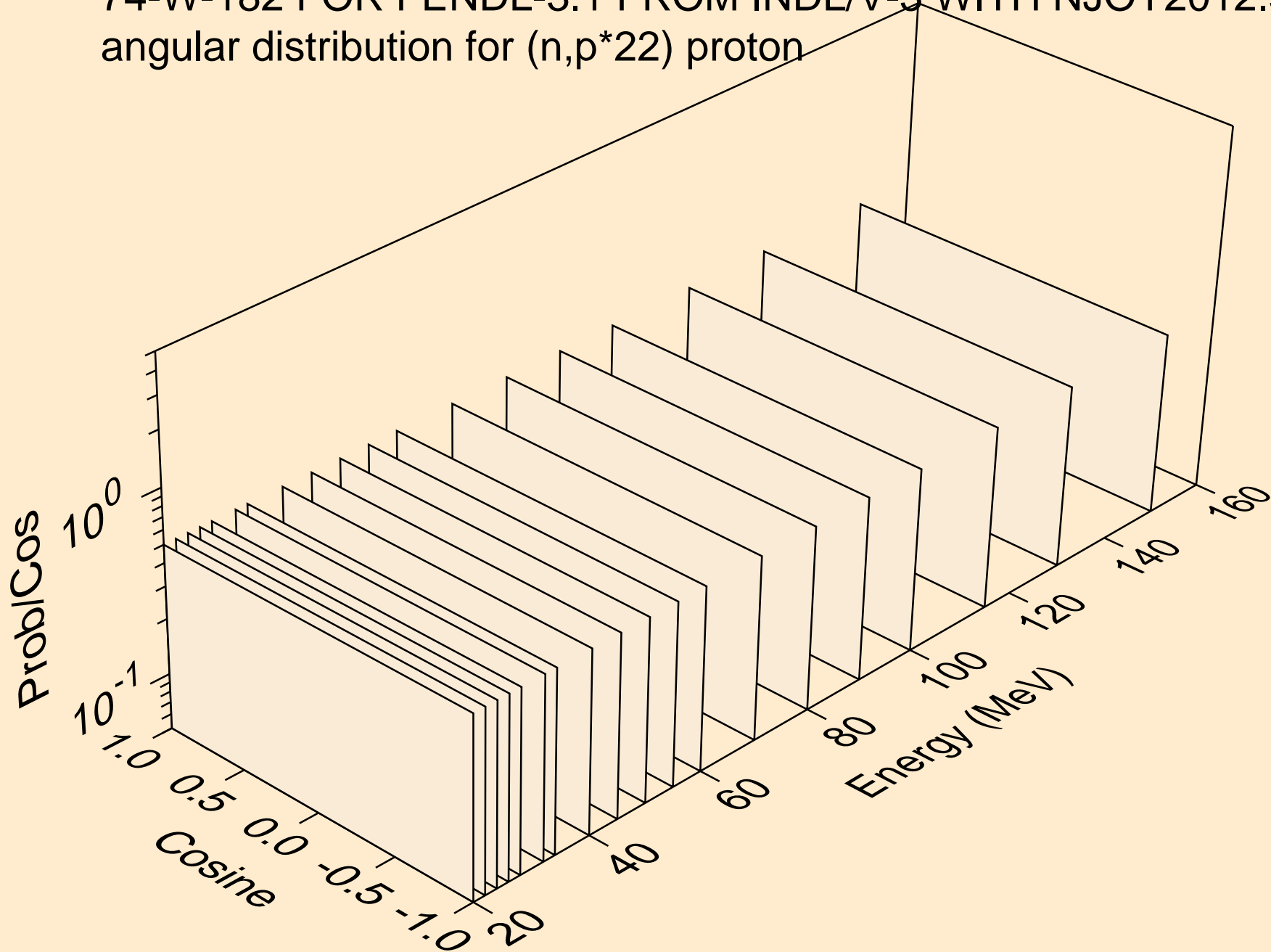

74-W-182 FOR FENDL-3.1 FROM INDL/V-3 WITH NJOY2012.50+ C
angular distribution for (n,p*23) proton

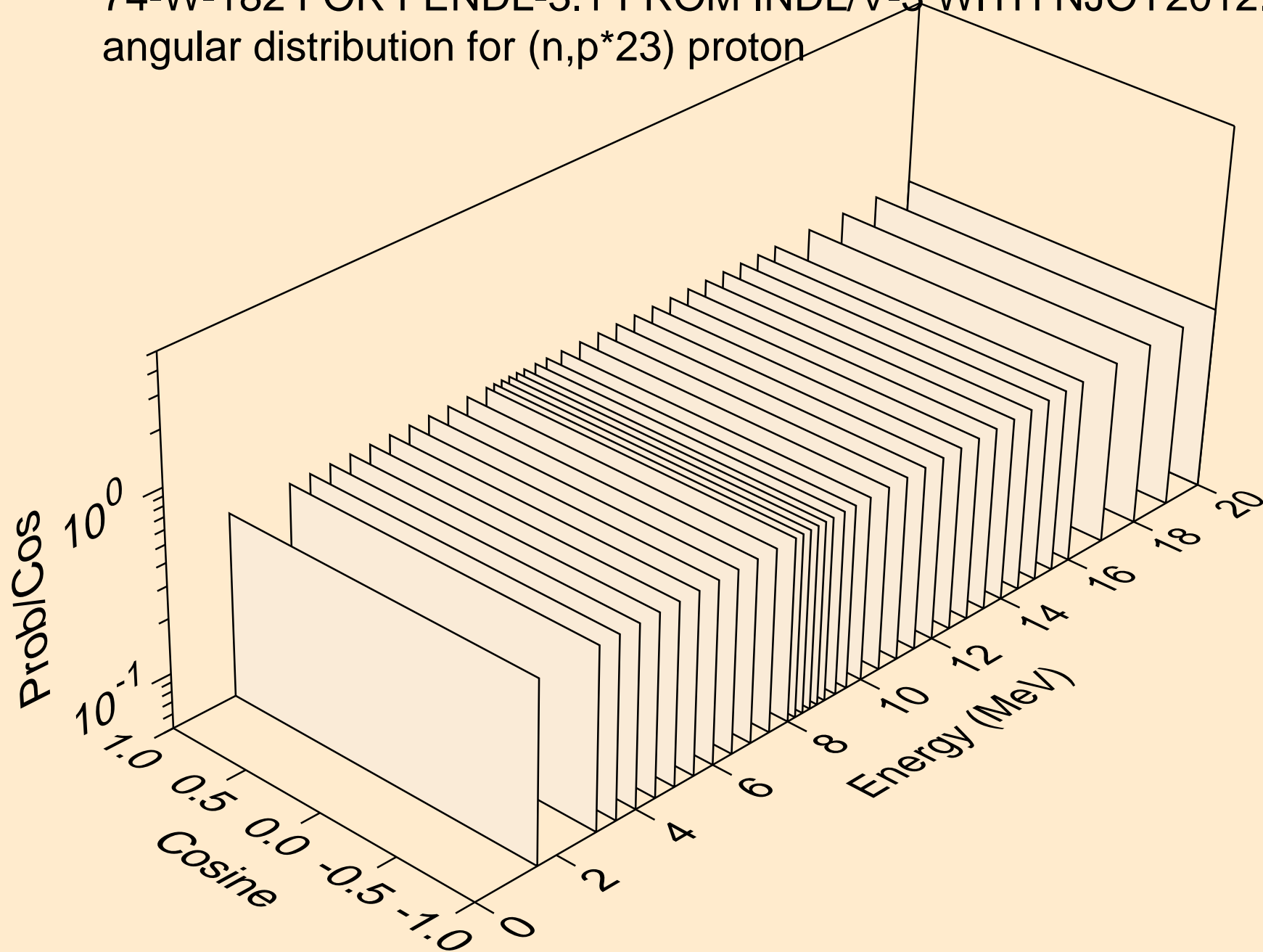

74-W-182 FOR FENDL-3.1 FROM INDL/V-3 WITH NJOY2012.50+ C
angular distribution for (n,p*23) proton

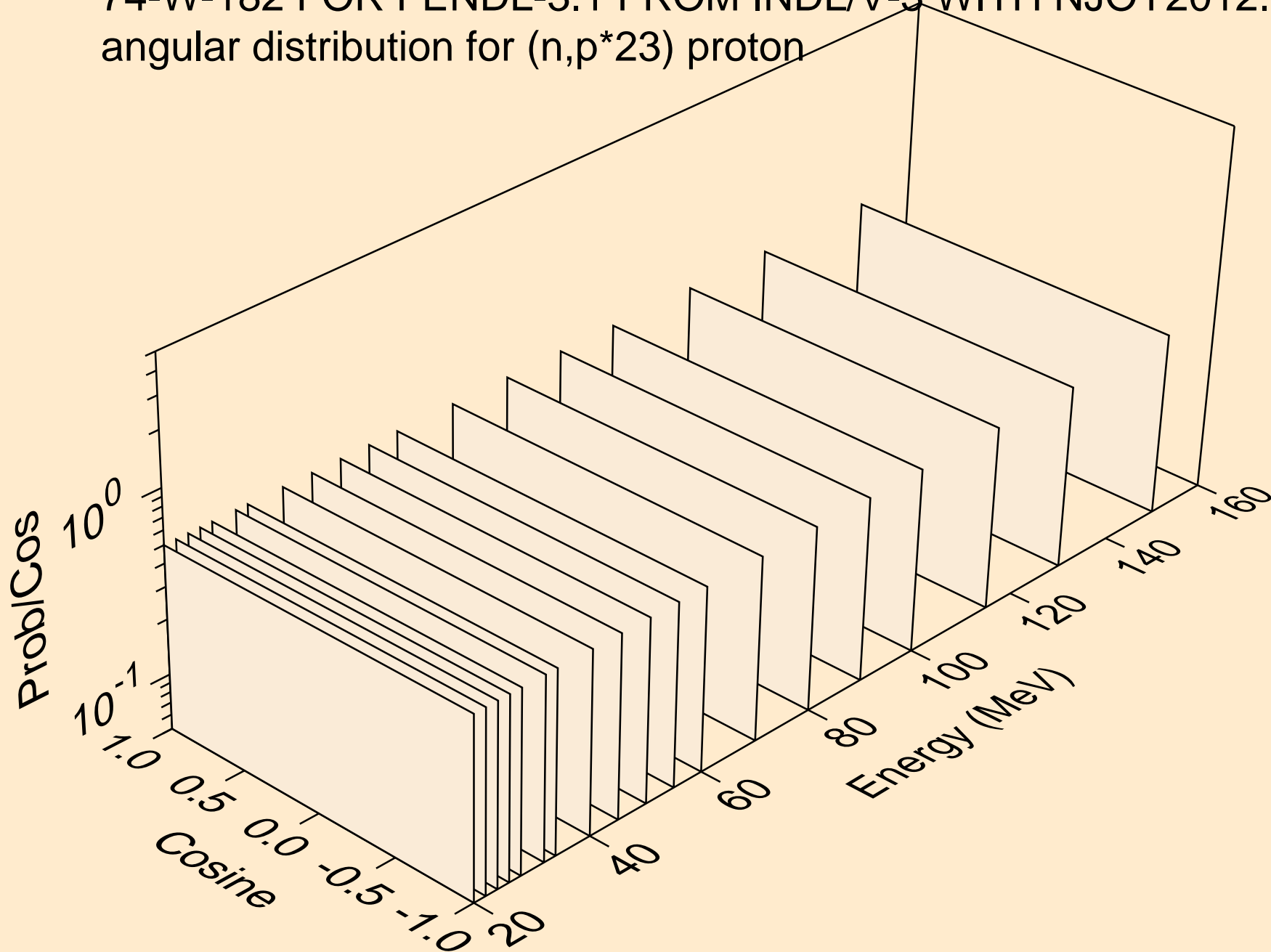

74-W-182 FOR FENDL-3.1 FROM INDL/V-3 WITH NJOY2012.50+ C
angular distribution for (n,p*24) proton

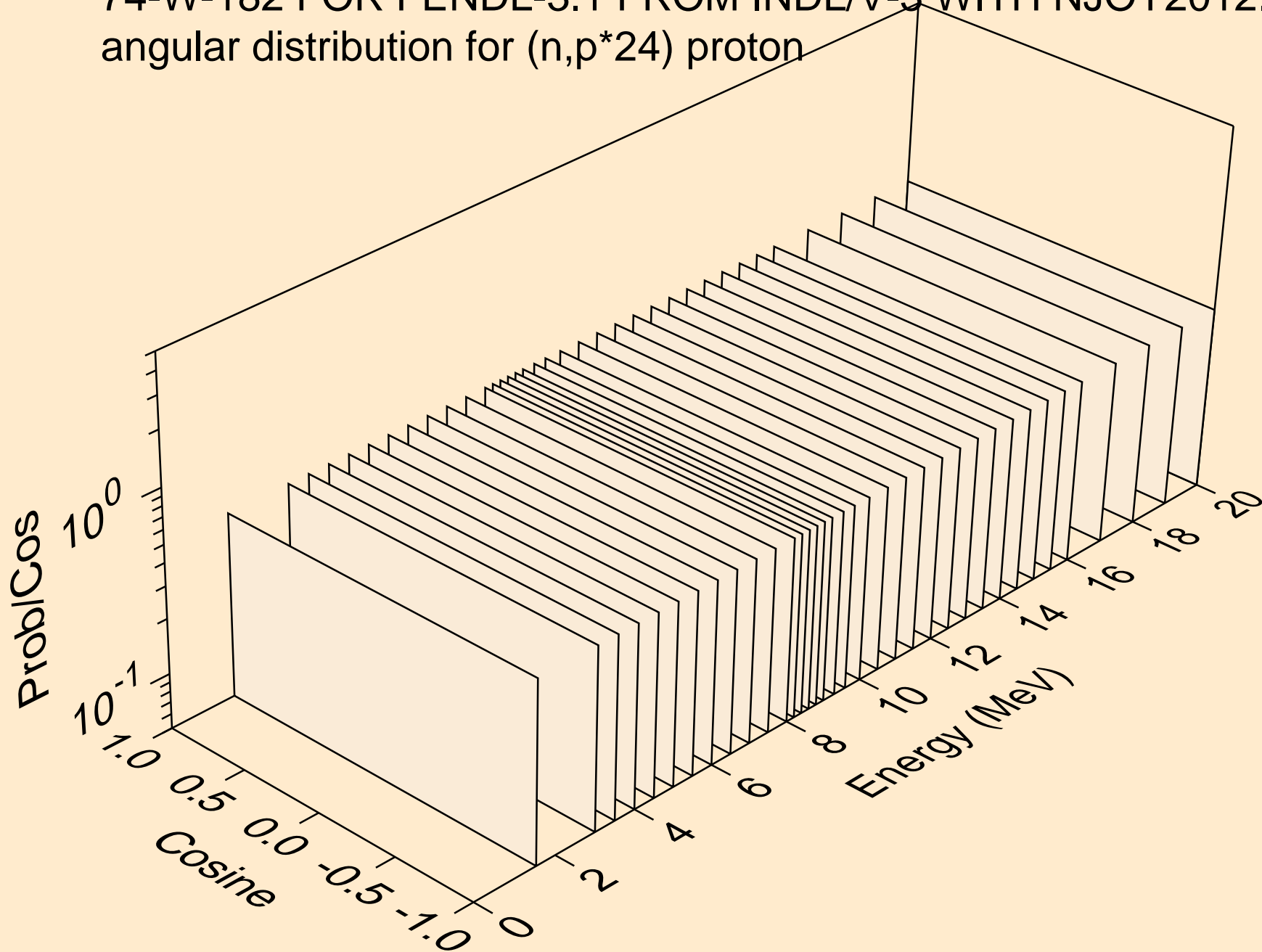

74-W-182 FOR FENDL-3.1 FROM INDL/V-3 WITH NJOY2012.50+ C
angular distribution for (n,p*24) proton

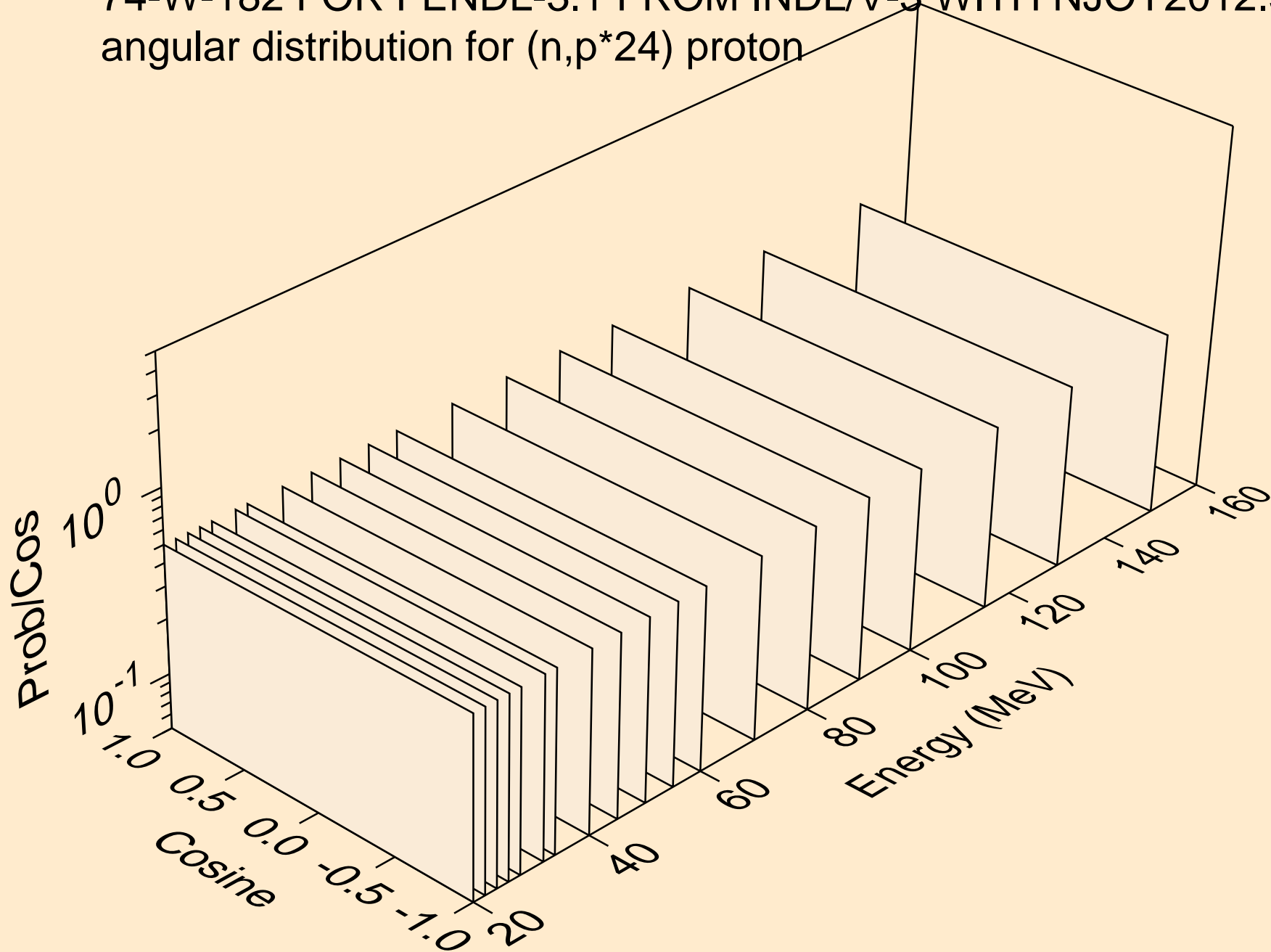

74-W-182 FOR FENDL-3.1 FROM INDL/V-3 WITH NJOY2012.50+ C
angular distribution for (n,p*25) proton

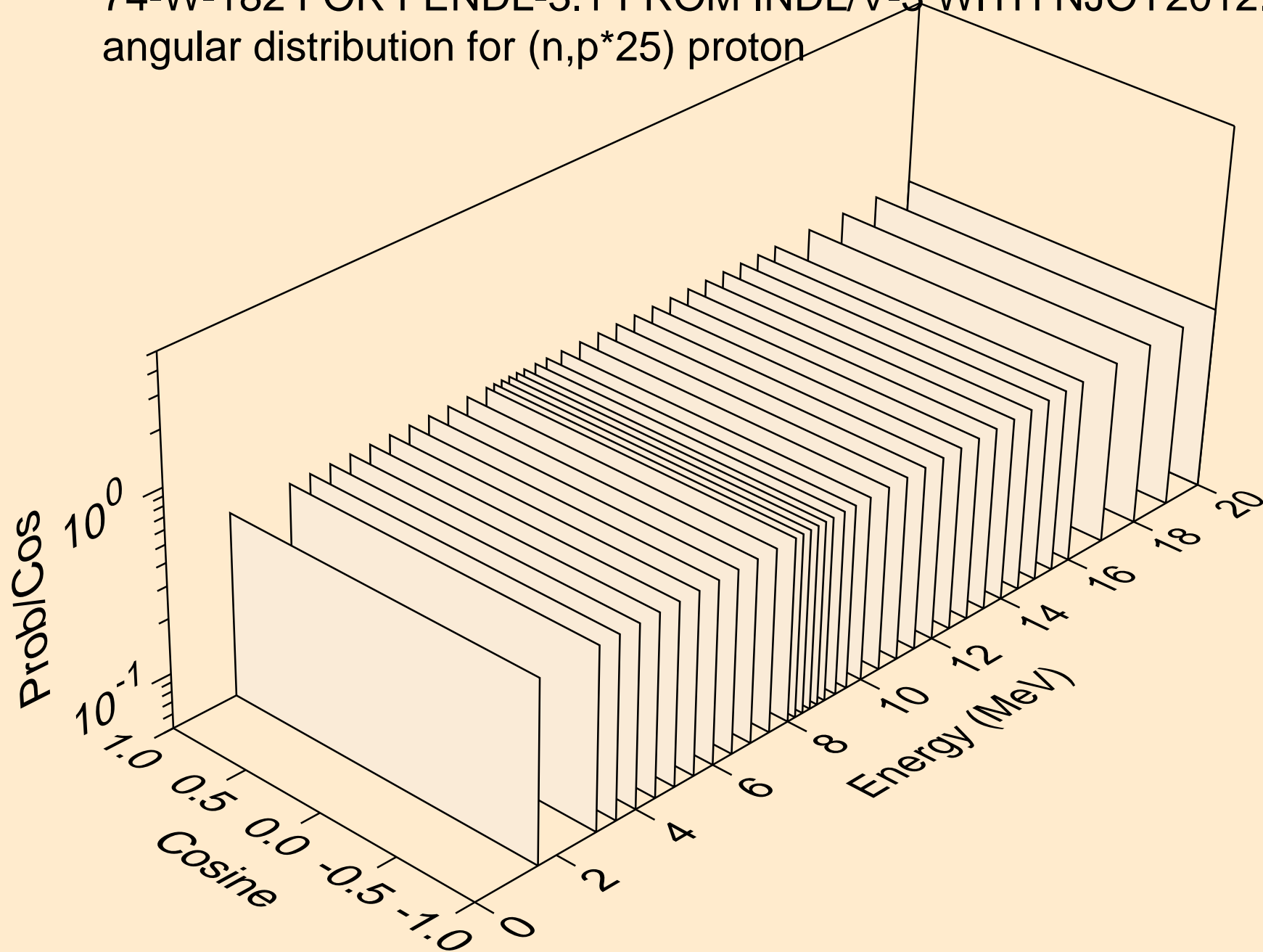

74-W-182 FOR FENDL-3.1 FROM INDL/V-3 WITH NJOY2012.50+ C
angular distribution for (n,p*25) proton

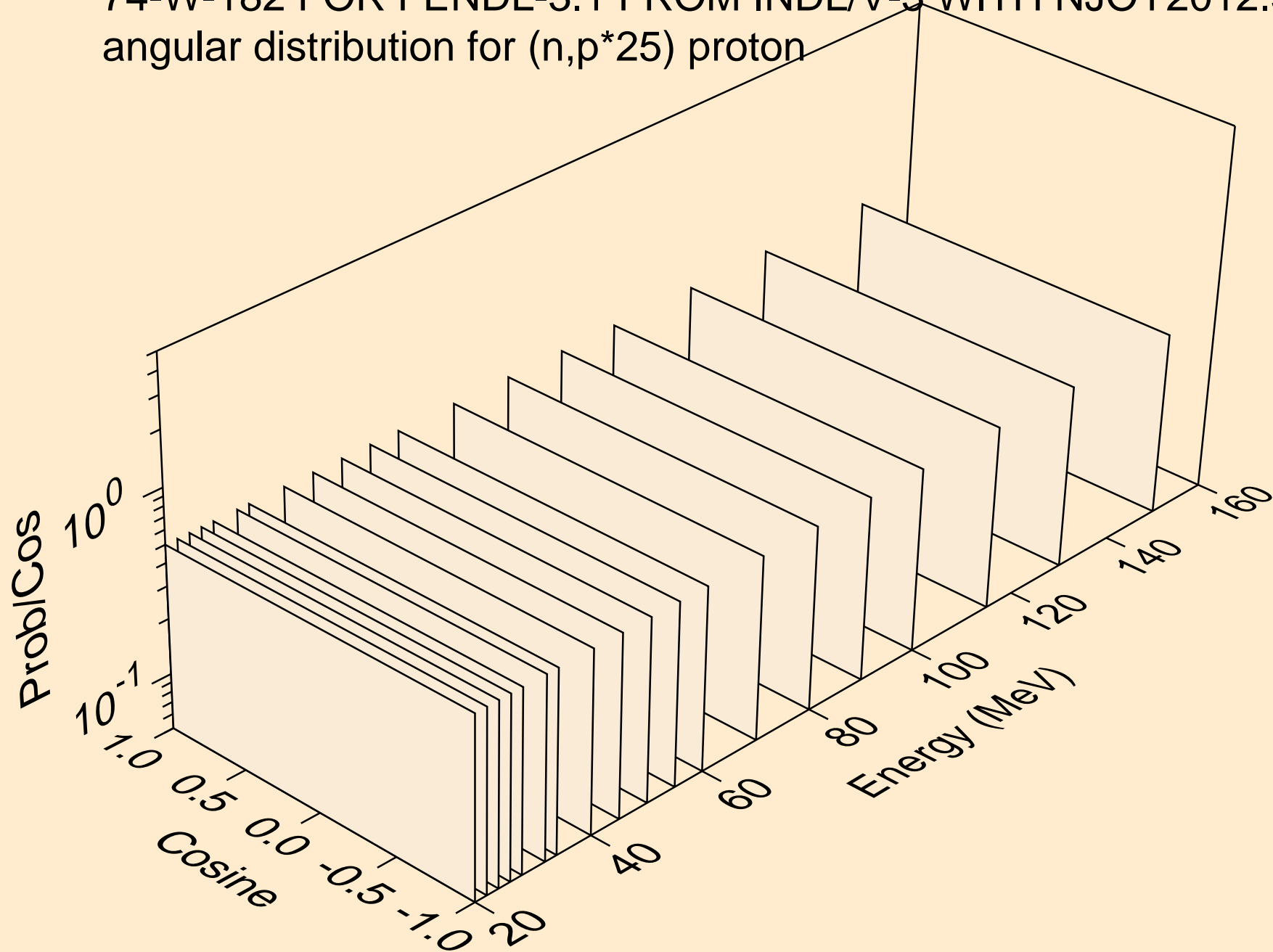

74-W-182 FOR FENDL-3.1 FROM INDL/V-3 WITH NJOY2012.50+ C
angular distribution for (n,p*26) proton

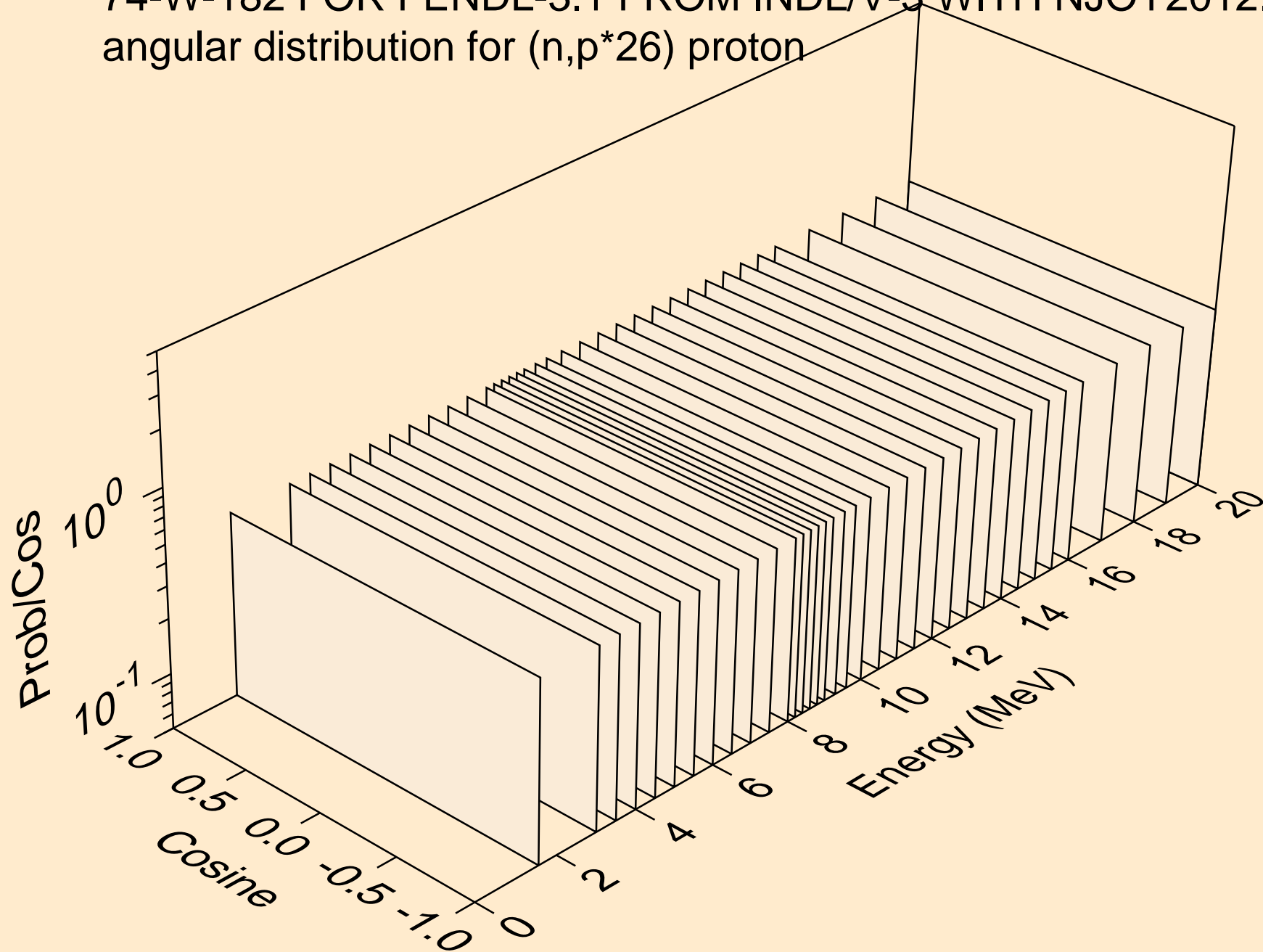

74-W-182 FOR FENDL-3.1 FROM INDL/V-3 WITH NJOY2012.50+ C
angular distribution for (n,p*26) proton

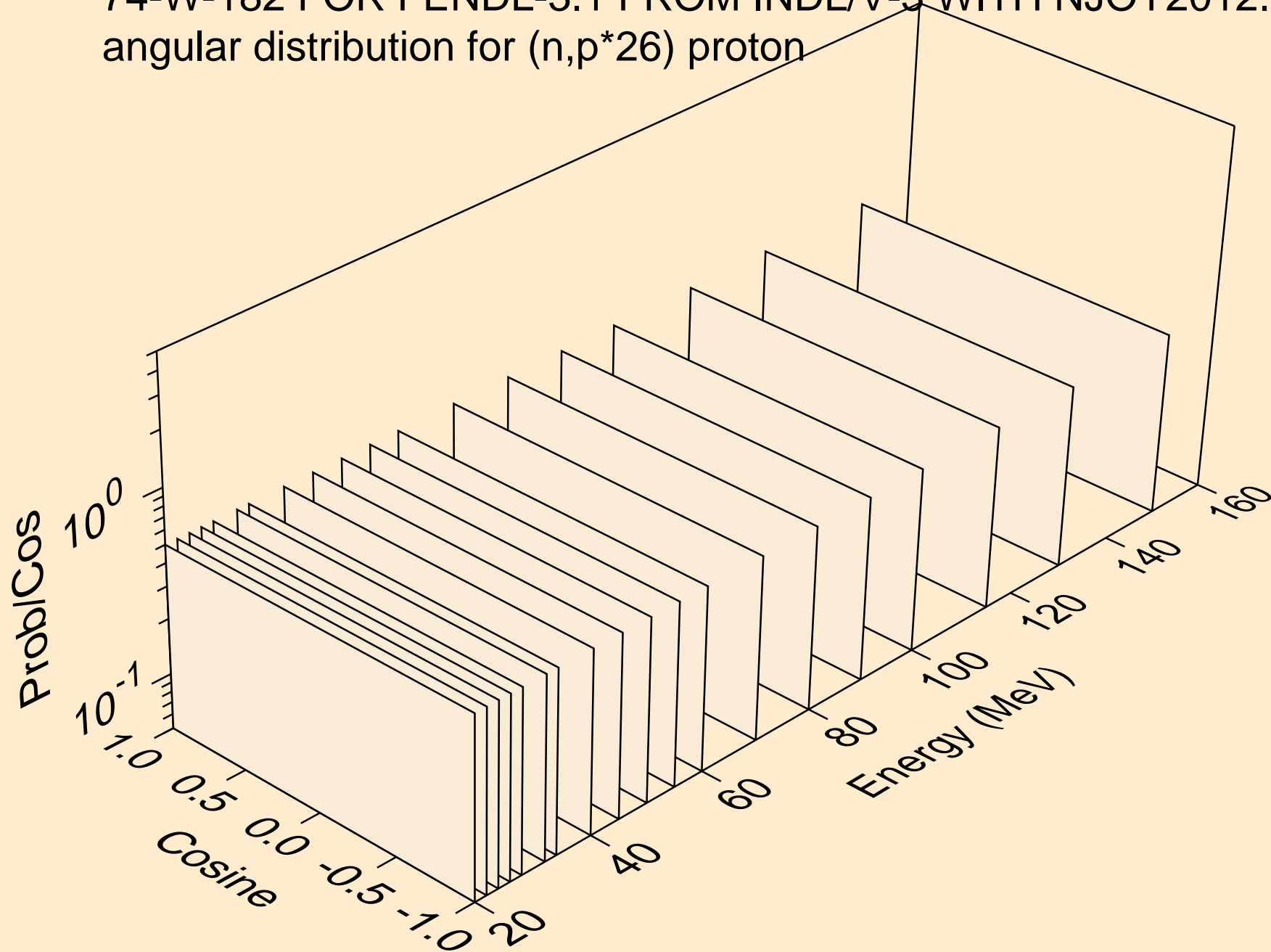

74-W-182 FOR FENDL-3.1 FROM INDL/V-3 WITH NJOY2012.50+ C
angular distribution for (n,p*27) proton

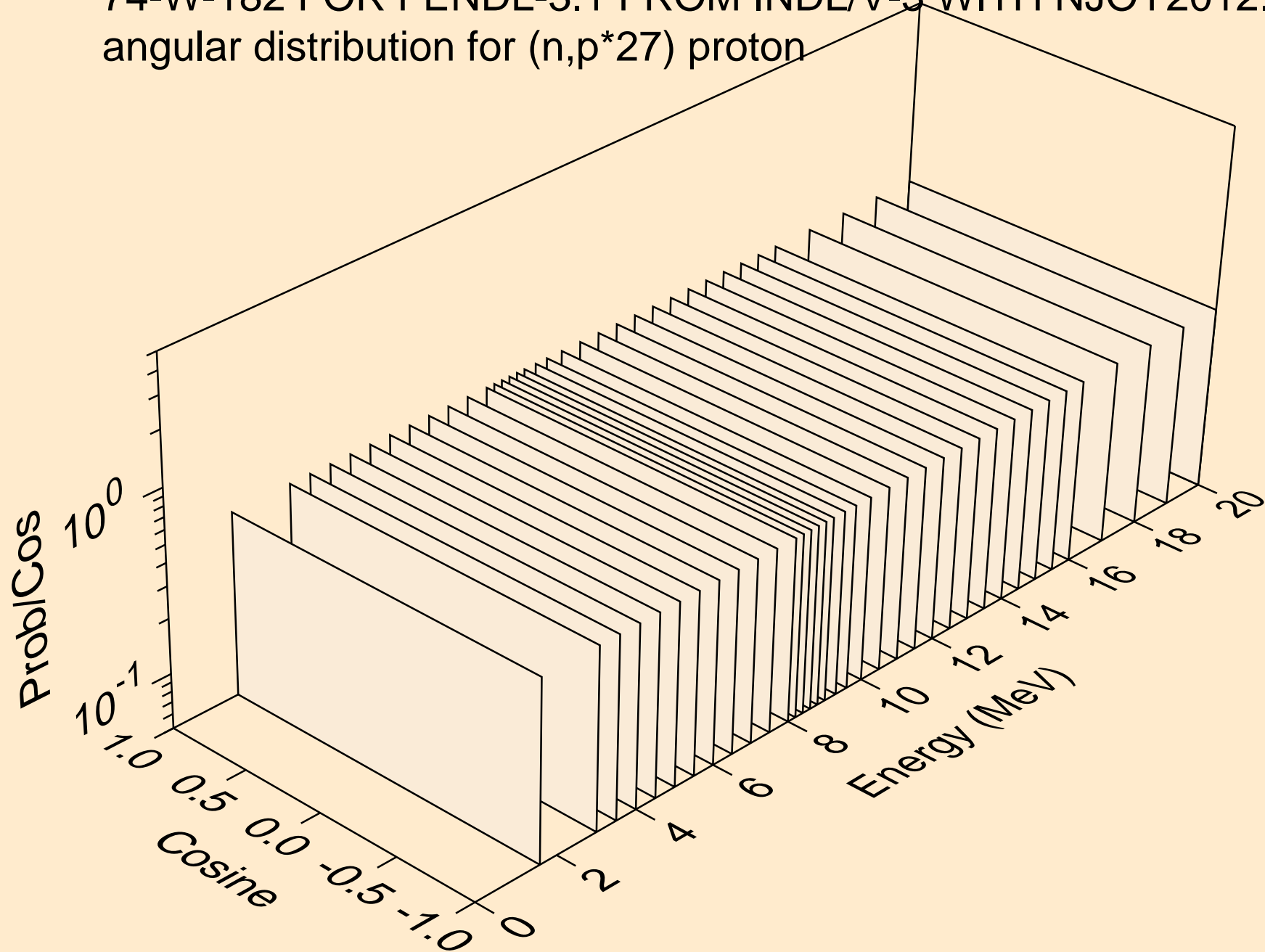

74-W-182 FOR FENDL-3.1 FROM INDL/V-3 WITH NJOY2012.50+ C
angular distribution for (n,p*27) proton

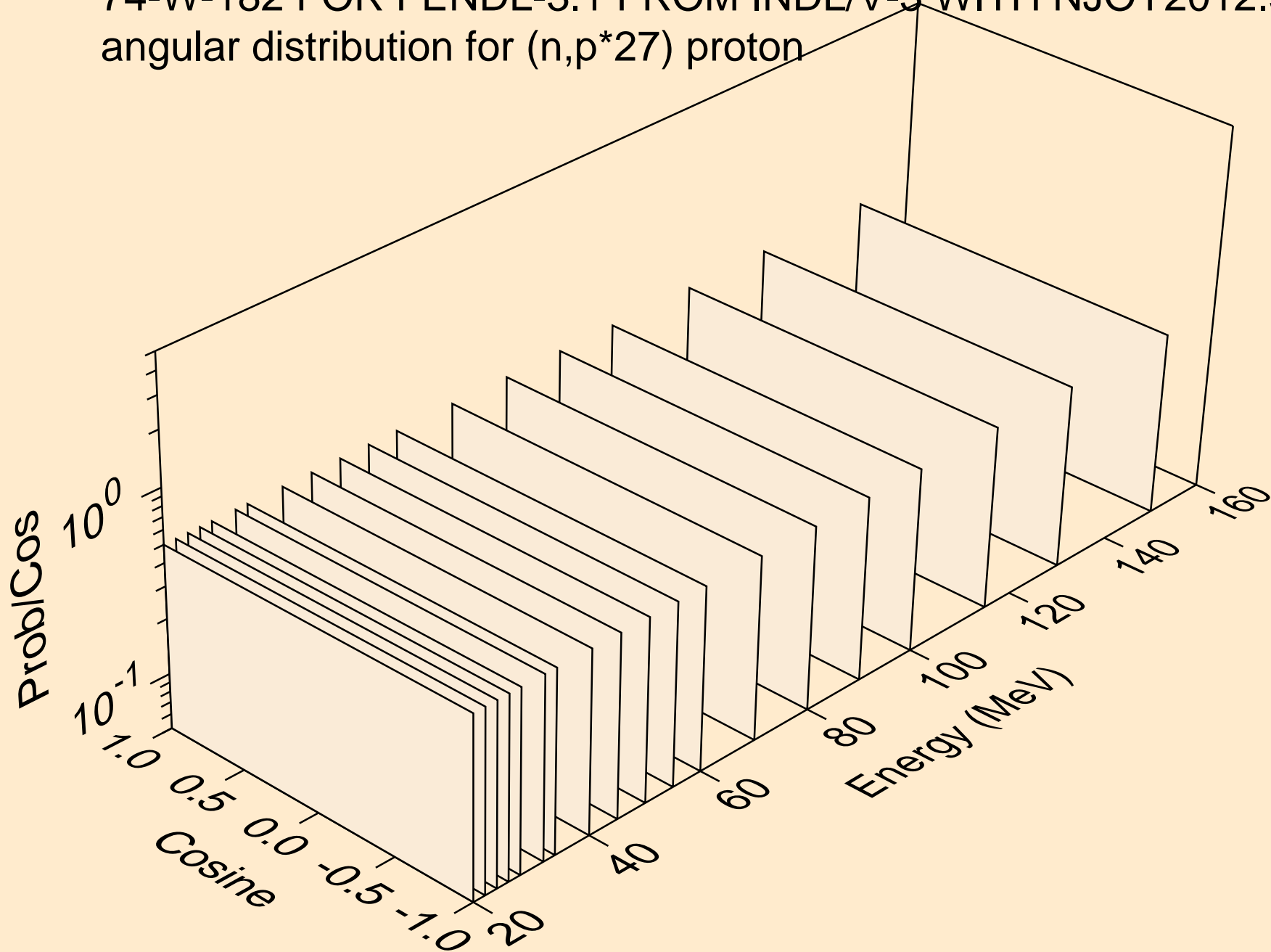

74-W-182 FOR FENDL-3.1 FROM INDL/V-3 WITH NJOY2012.50+ C
angular distribution for (n,p*28) proton

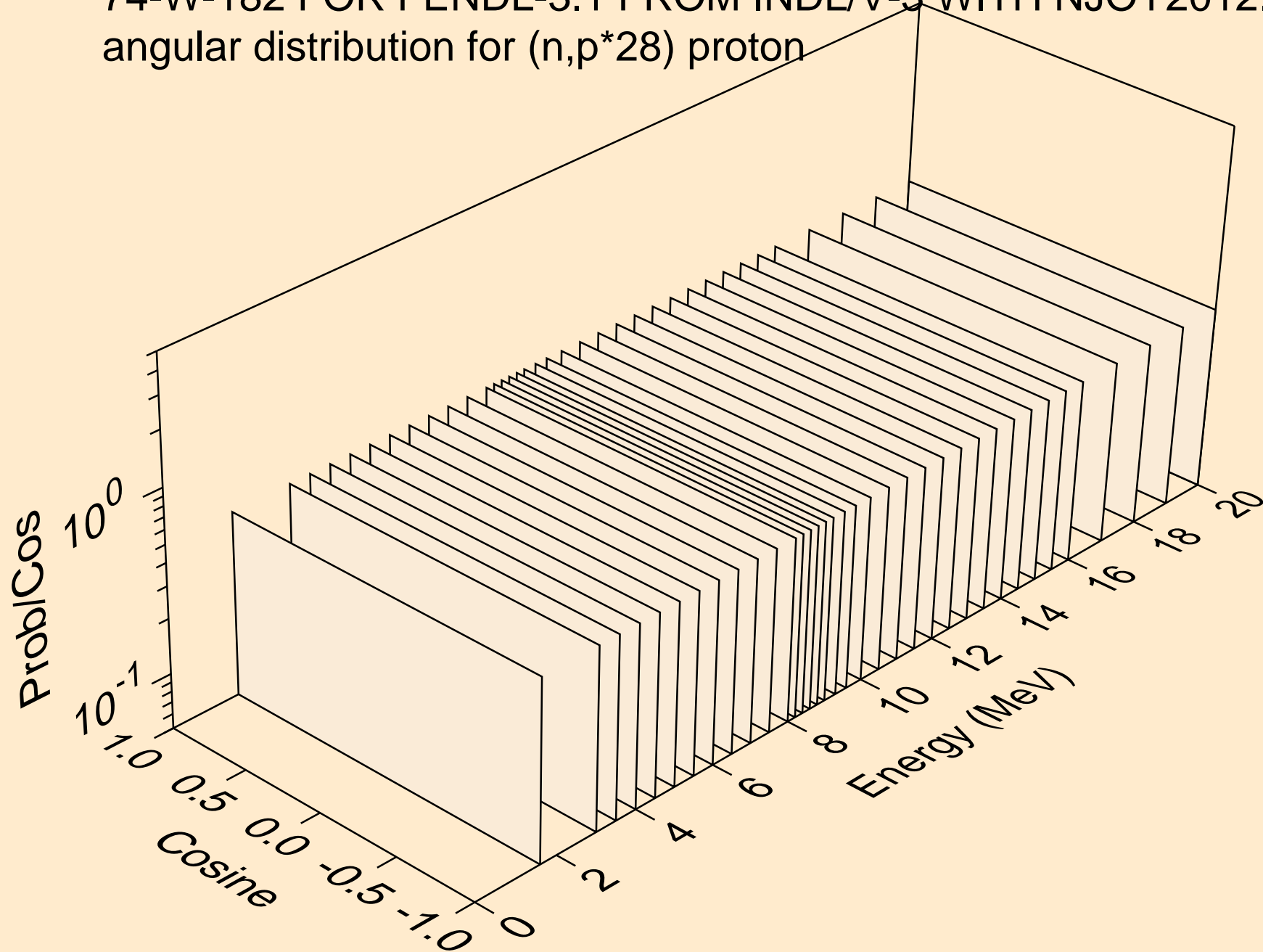

74-W-182 FOR FENDL-3.1 FROM INDL/V-3 WITH NJOY2012.50+ C
angular distribution for (n,p*28) proton

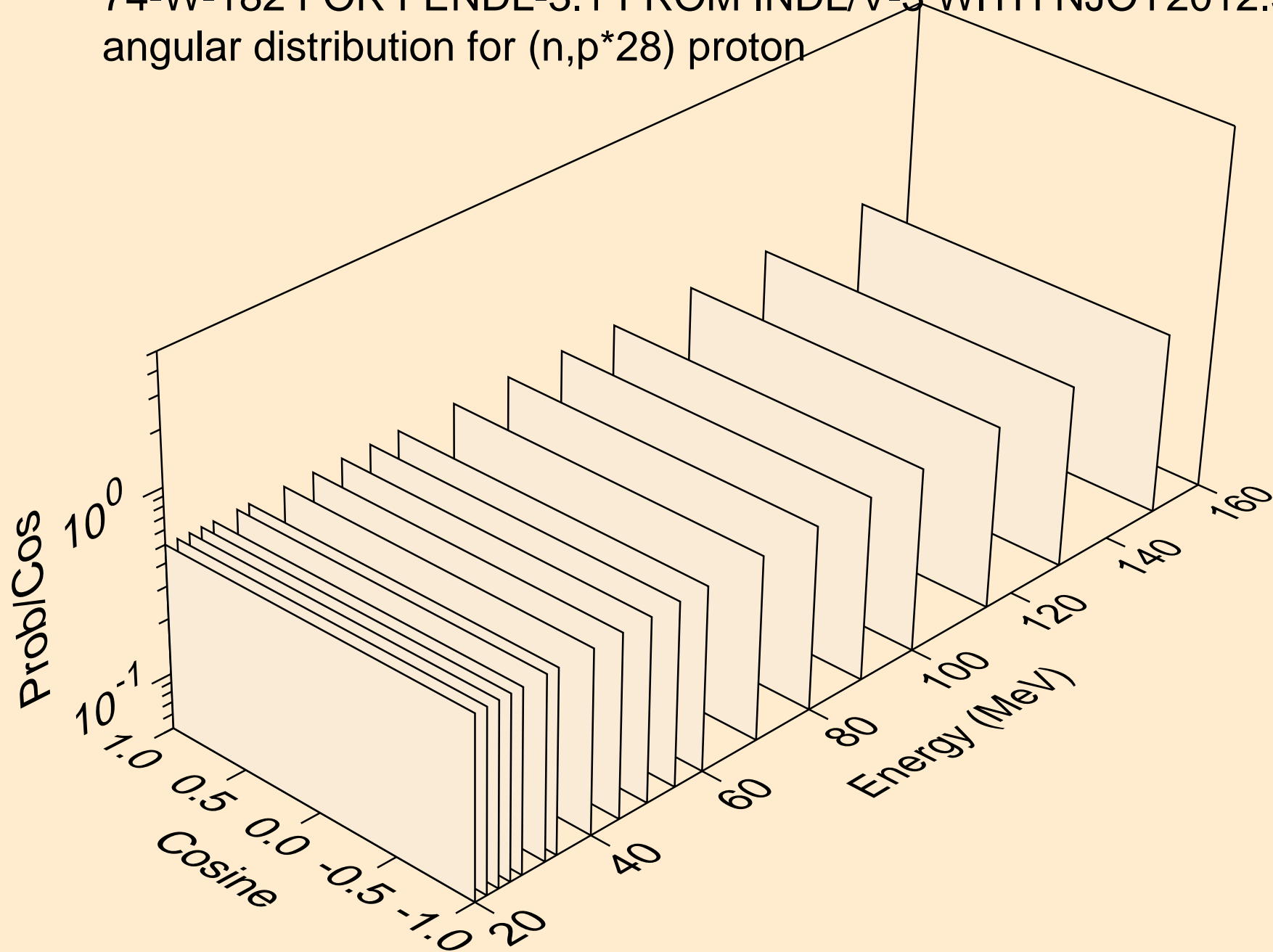

74-W-182 FOR FENDL-3.1 FROM INDL/V-3 WITH NJOY2012.50+ C
angular distribution for (n,p*29) proton

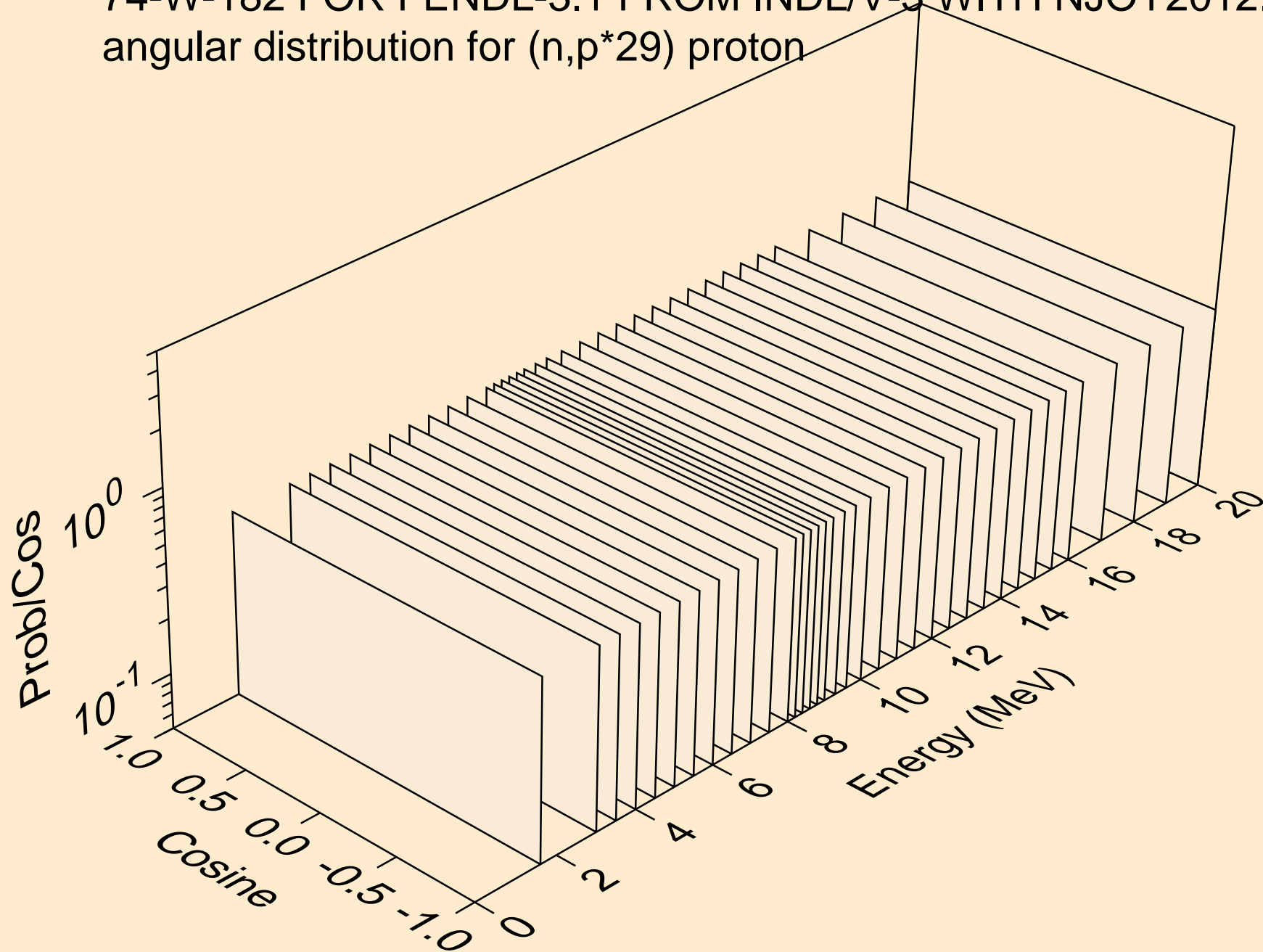

74-W-182 FOR FENDL-3.1 FROM INDL/V-3 WITH NJOY2012.50+ C
angular distribution for (n,p*29) proton

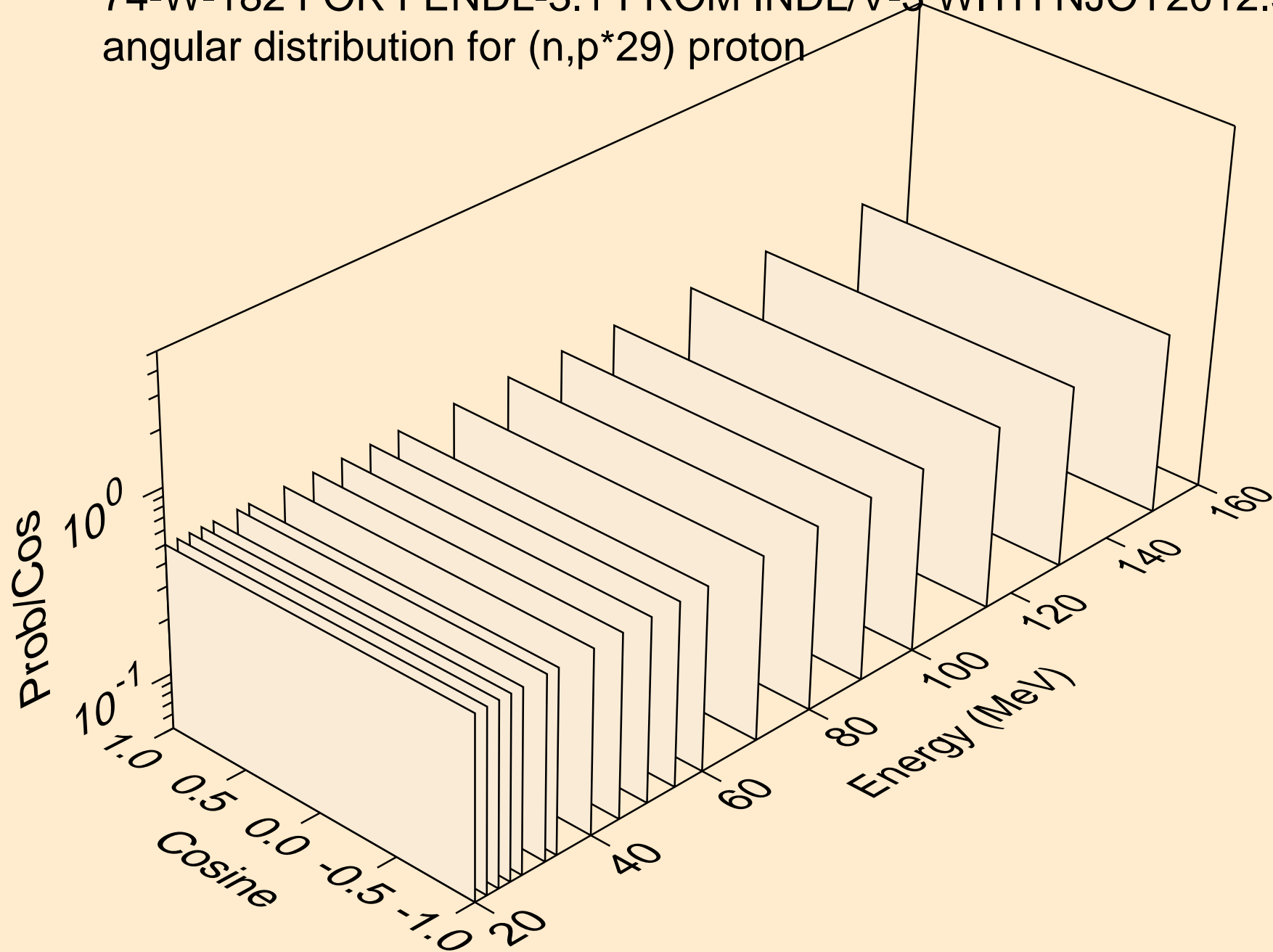

74-W-182 FOR FENDL-3.1 FROM INDLV-3 WITH NJOY2012.50+ C
protons from (n,p*c)

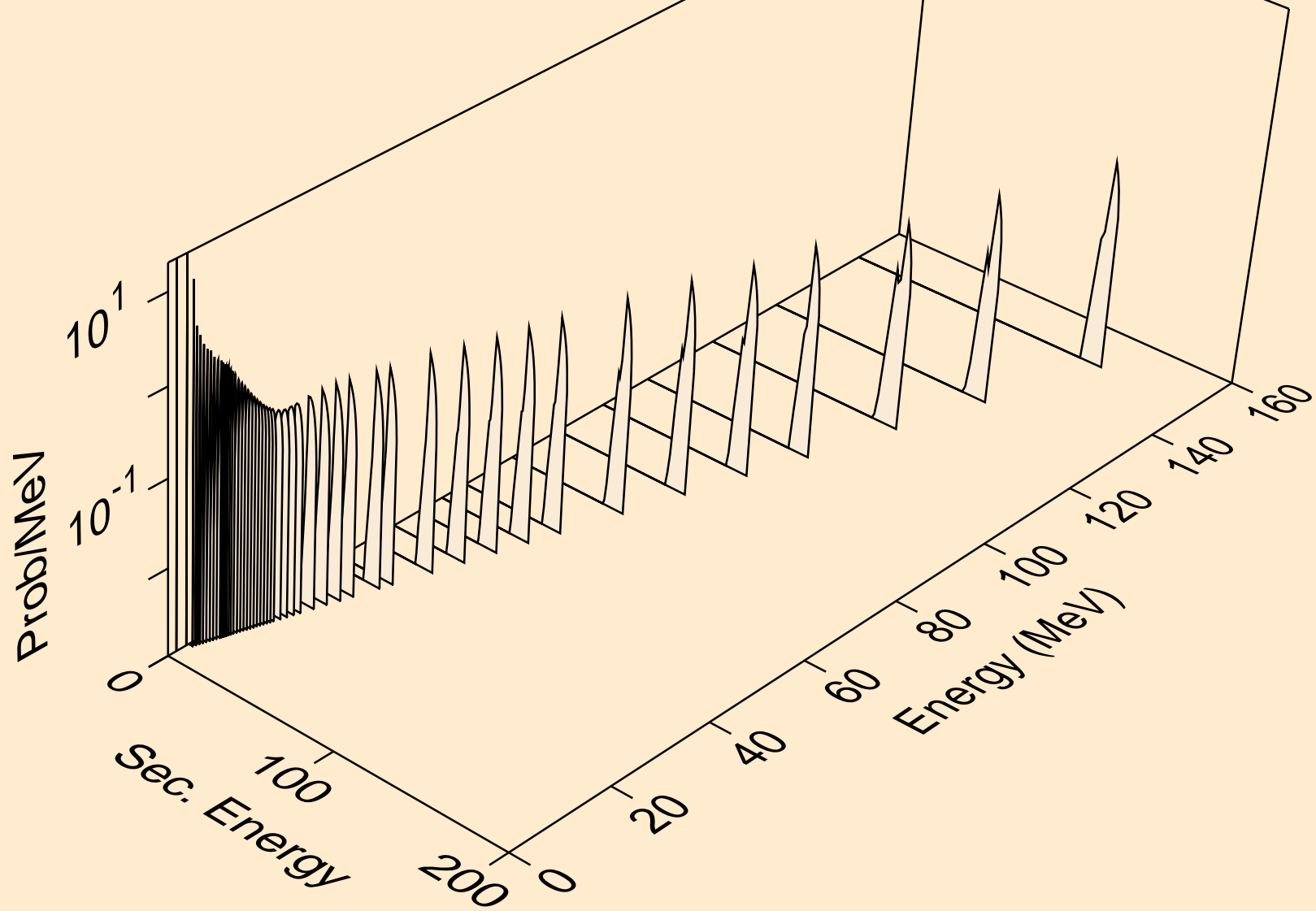

74-W-182 FOR FENDL-3.1 FROM INDLV-3 WITH NJOY2012.50+ C
alphas from (n,x)

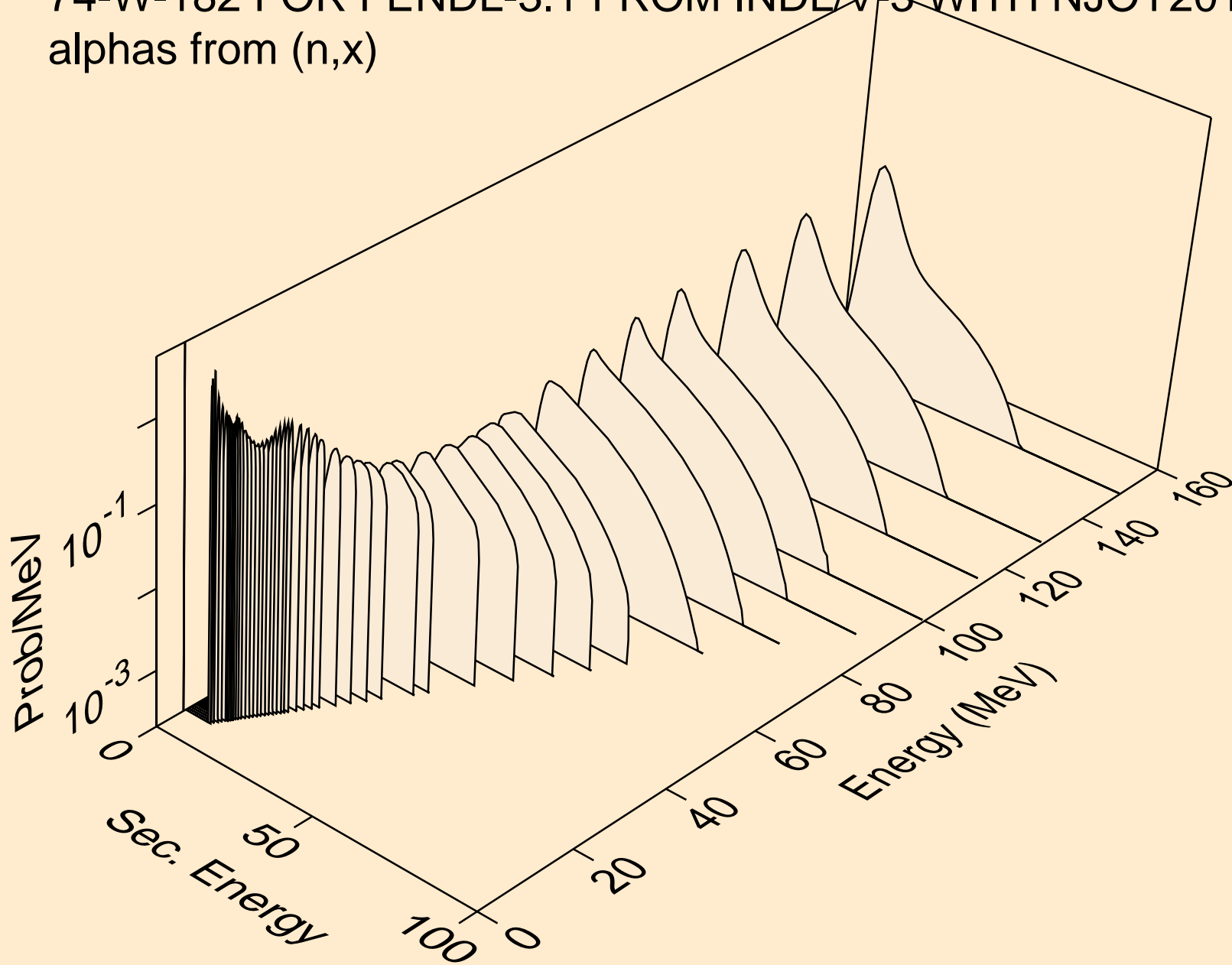

74-W-182 FOR FENDL-3.1 FROM INDL/V-3 WITH NJOY2012.50+ C
angular distribution for (n,a*0) alpha

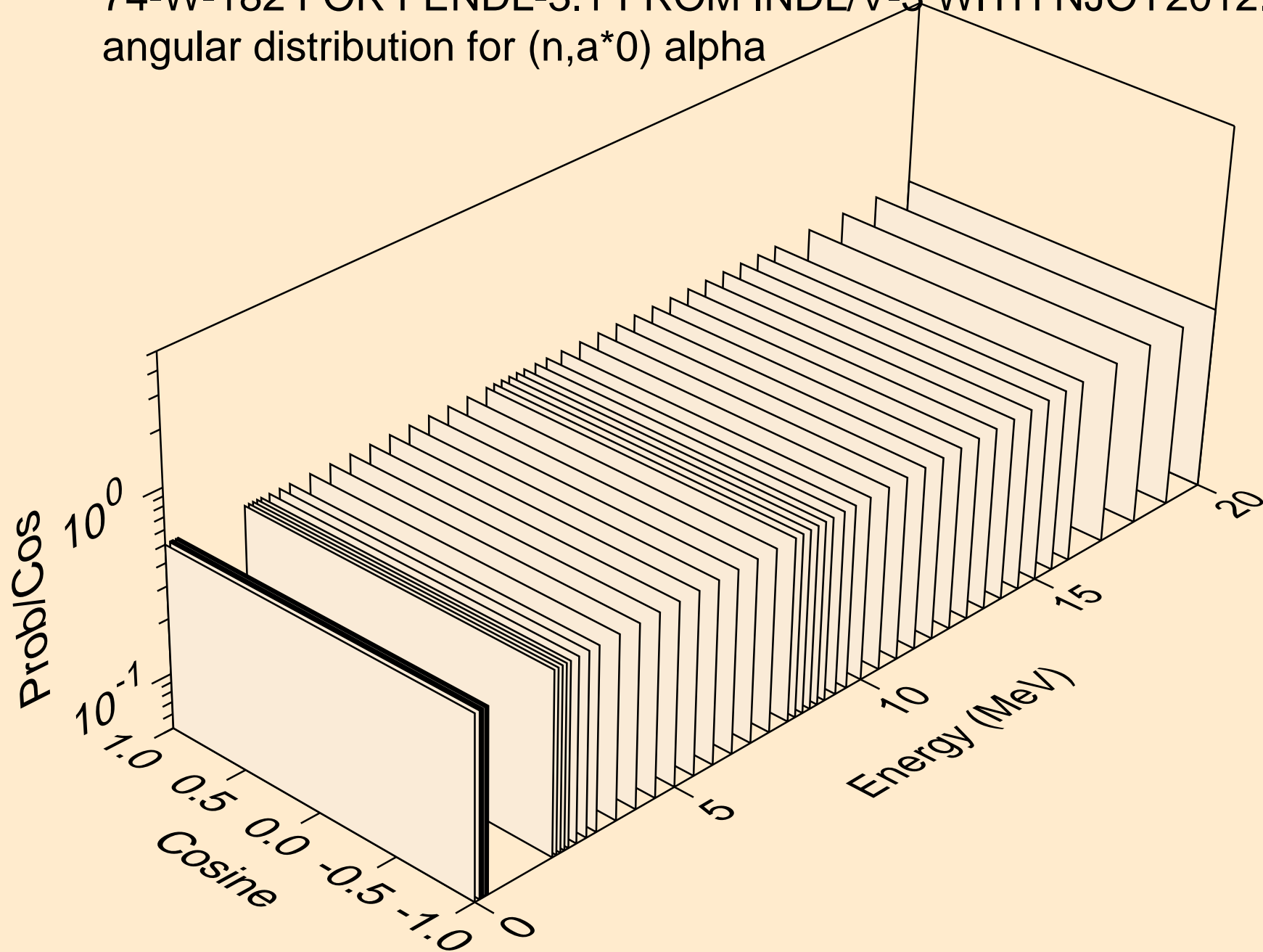

74-W-182 FOR FENDL-3.1 FROM INDL/V-3 WITH NJOY2012.50+ C
angular distribution for (n,a*0) alpha

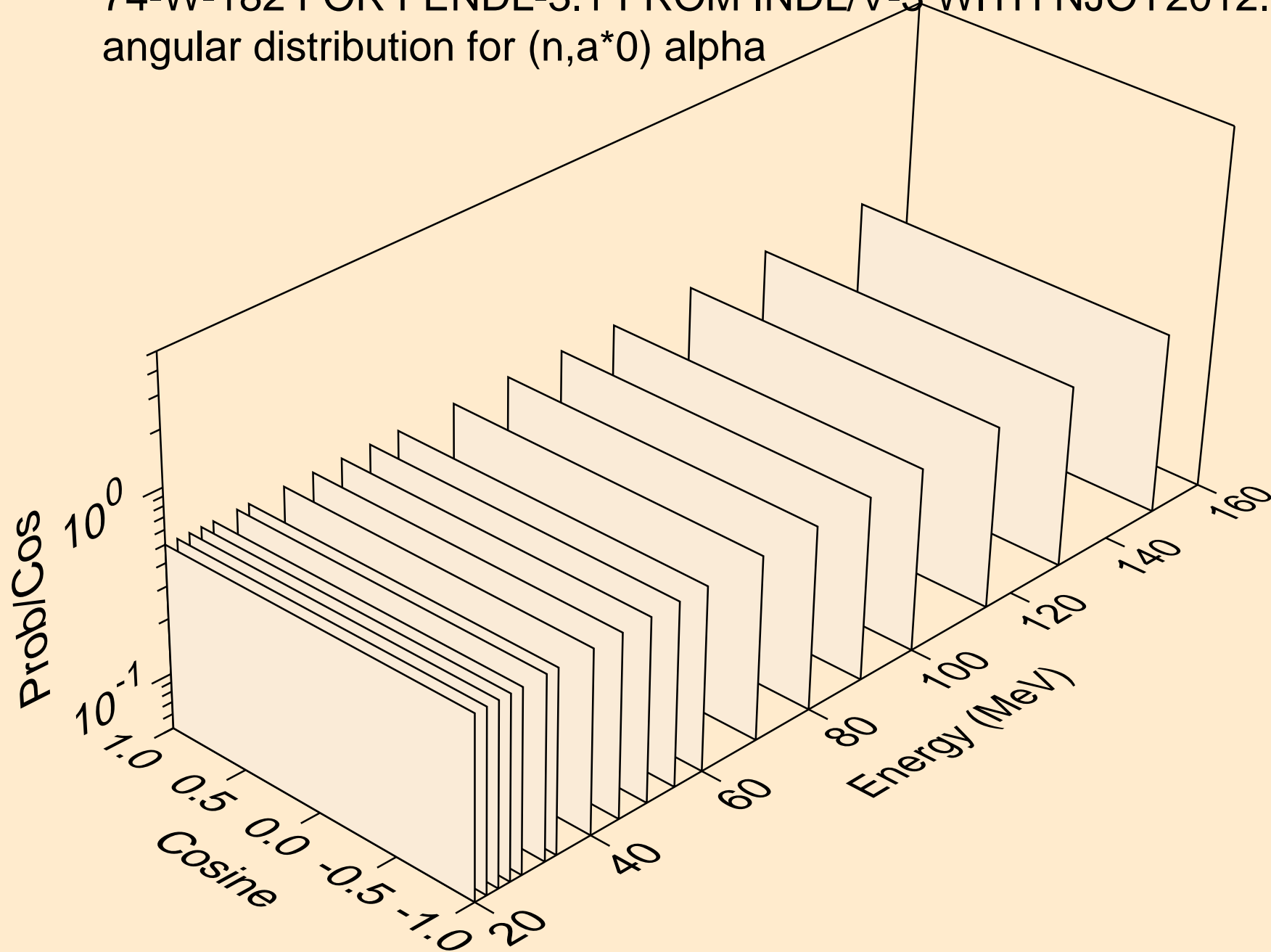

74-W-182 FOR FENDL-3.1 FROM INDL/V-3 WITH NJOY2012.50+ C
angular distribution for (n,a*1) alpha

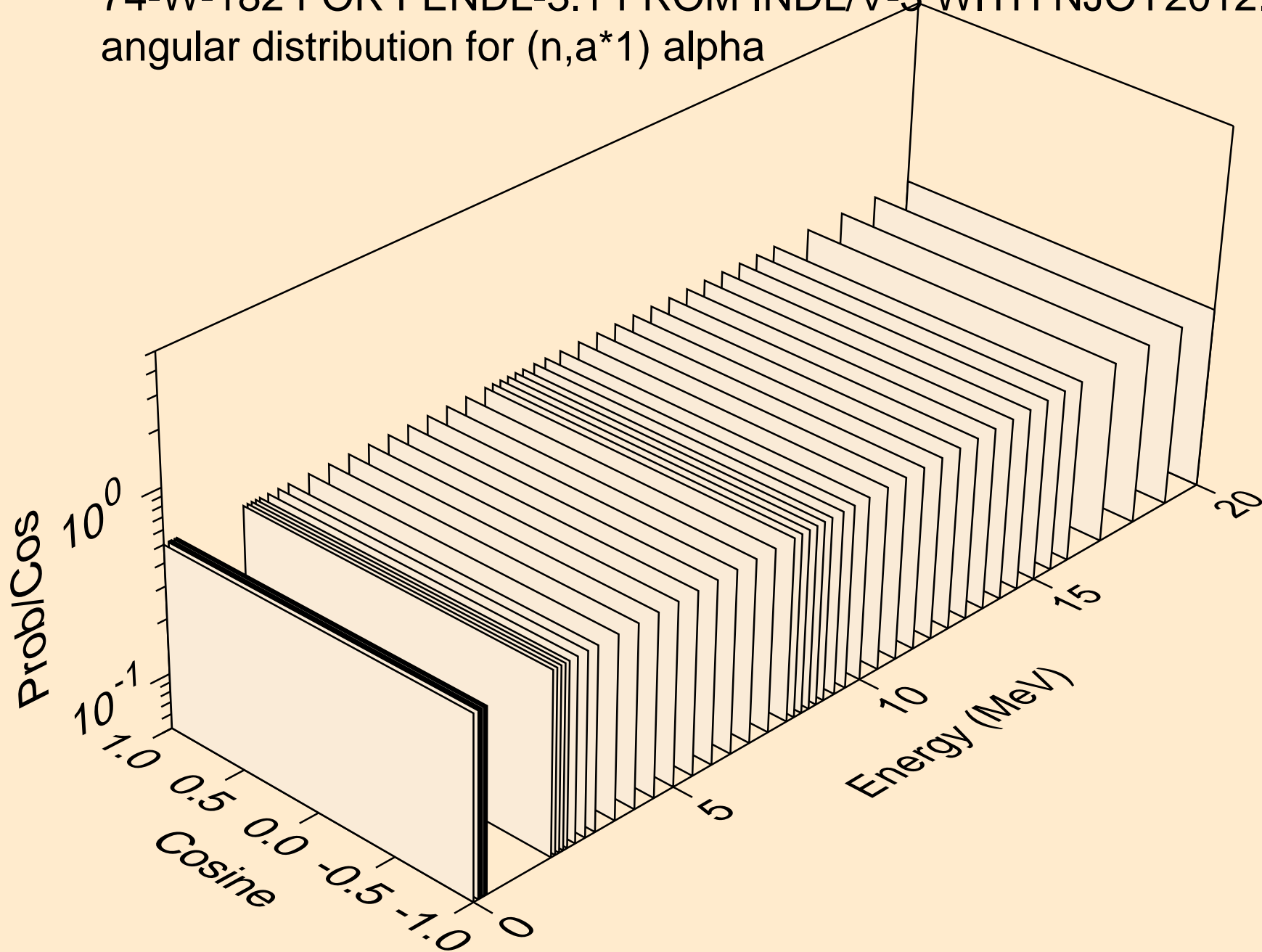

74-W-182 FOR FENDL-3.1 FROM INDL/V-3 WITH NJOY2012.50+ C
angular distribution for (n,a*1) alpha

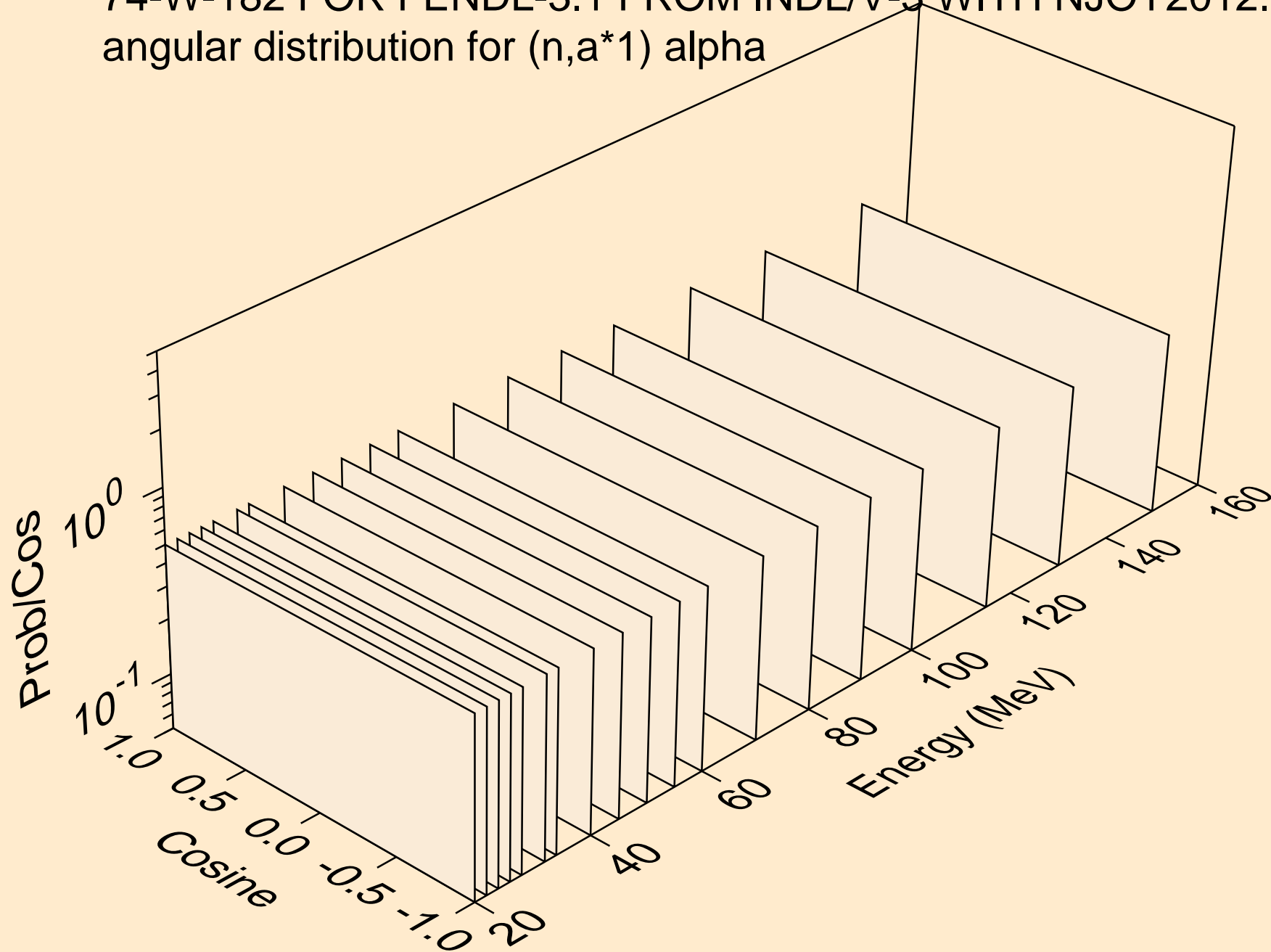

74-W-182 FOR FENDL-3.1 FROM INDL/V-3 WITH NJOY2012.50+ C
angular distribution for (n,a*2) alpha

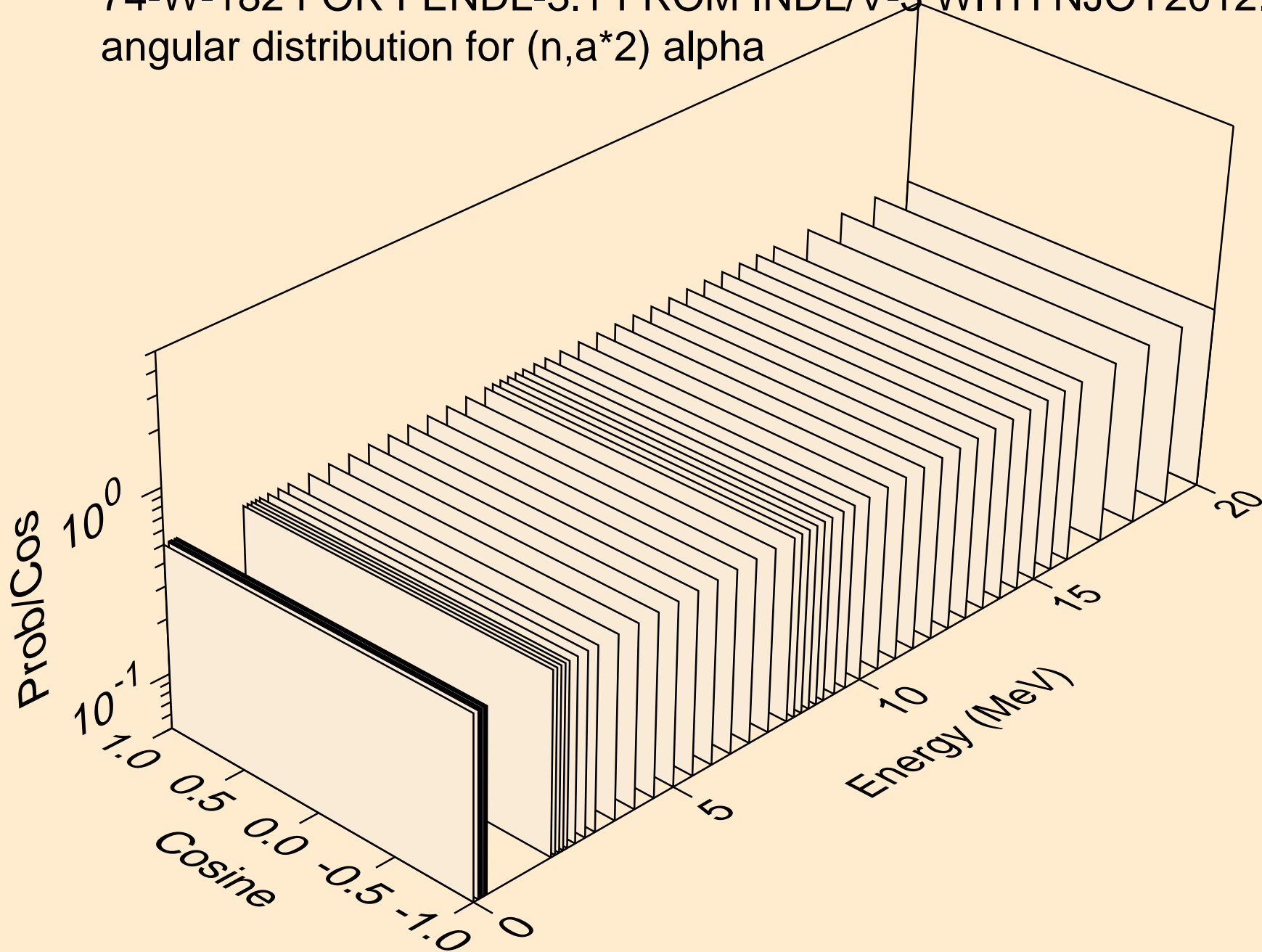

74-W-182 FOR FENDL-3.1 FROM INDL/V-3 WITH NJOY2012.50+ C
angular distribution for (n,a*2) alpha

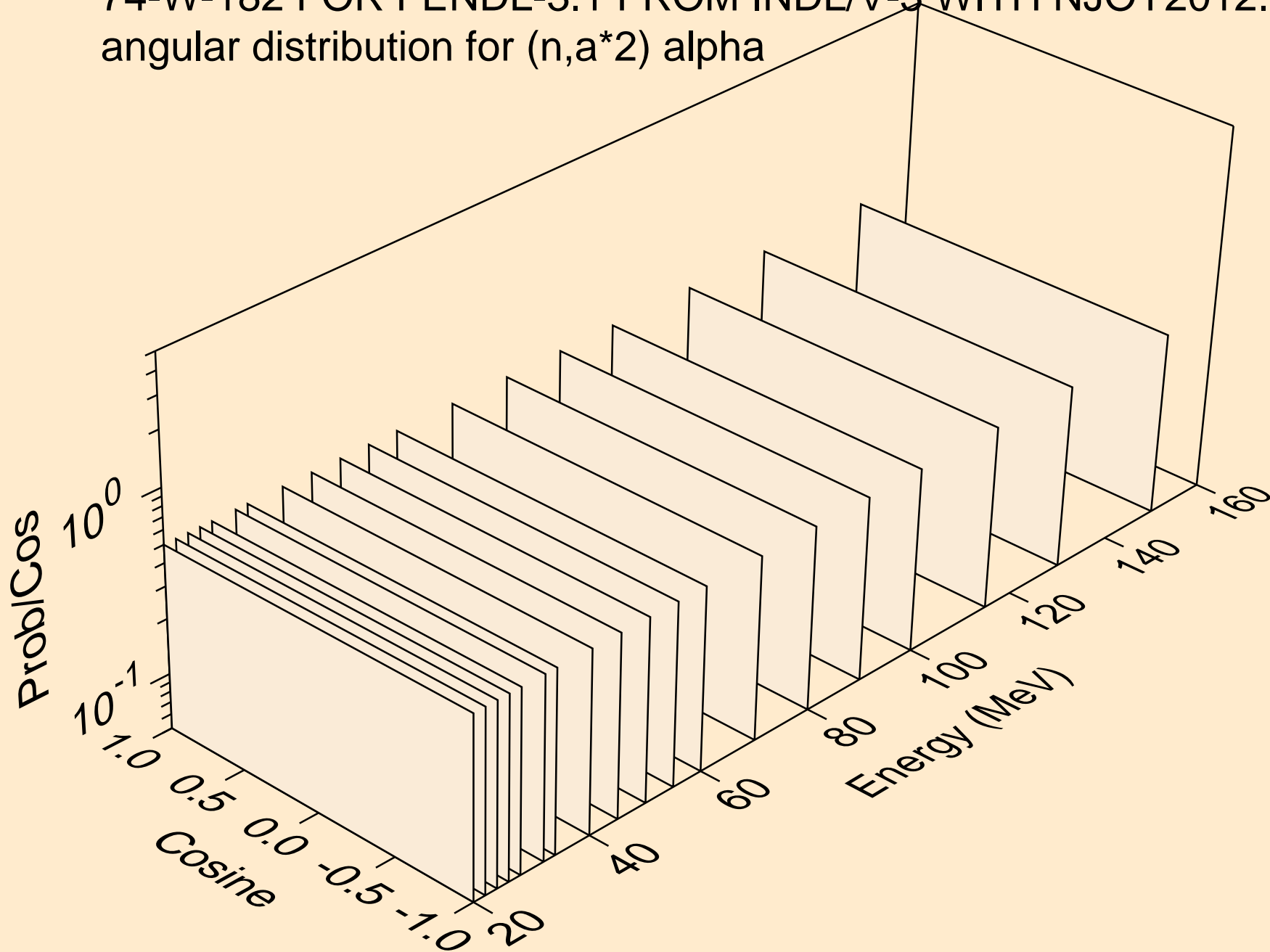

74-W-182 FOR FENDL-3.1 FROM INDL/V-3 WITH NJOY2012.50+ C
angular distribution for (n,a*3) alpha

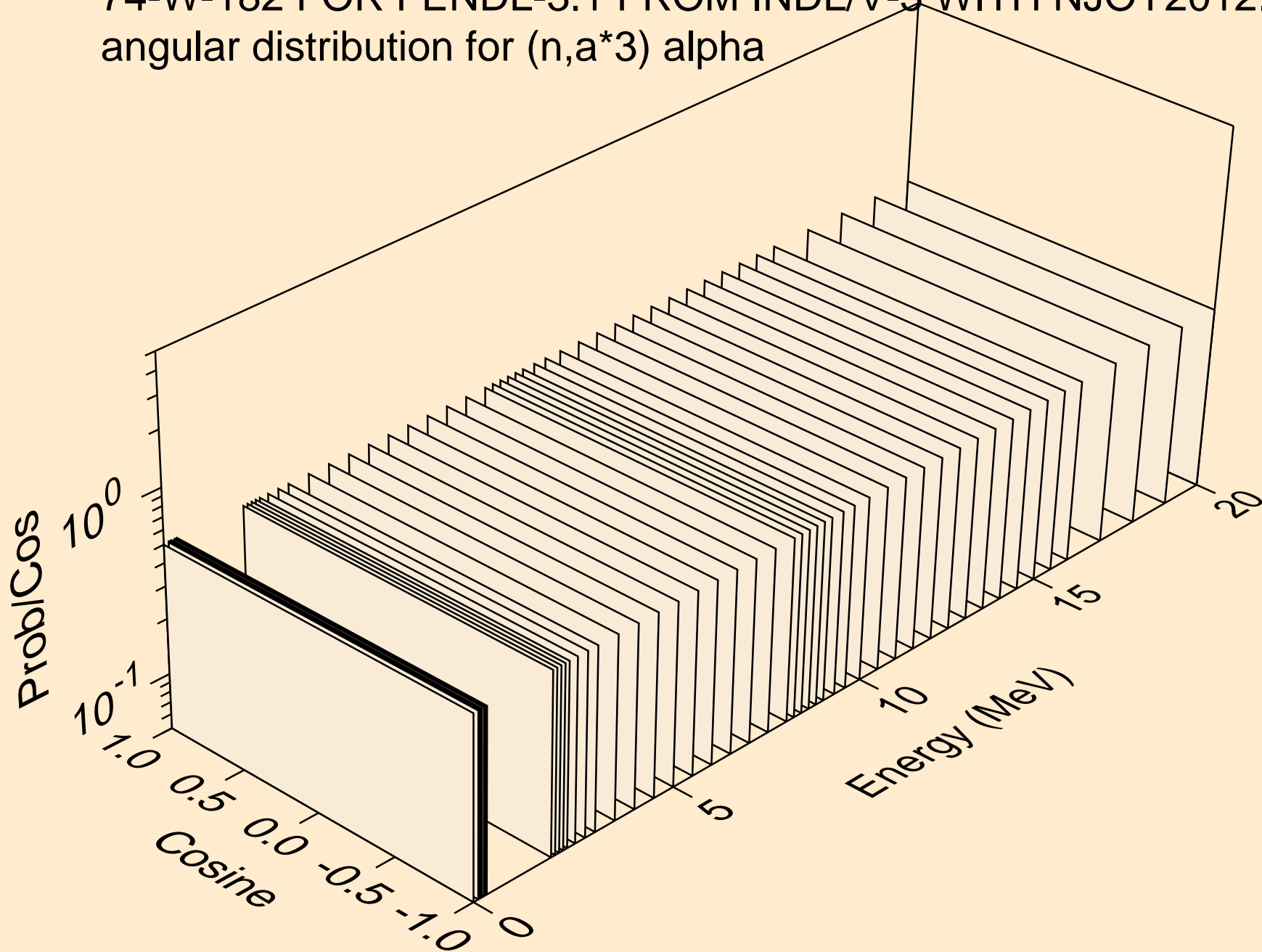

74-W-182 FOR FENDL-3.1 FROM INDL/V-3 WITH NJOY2012.50+ C
angular distribution for (n,a*3) alpha

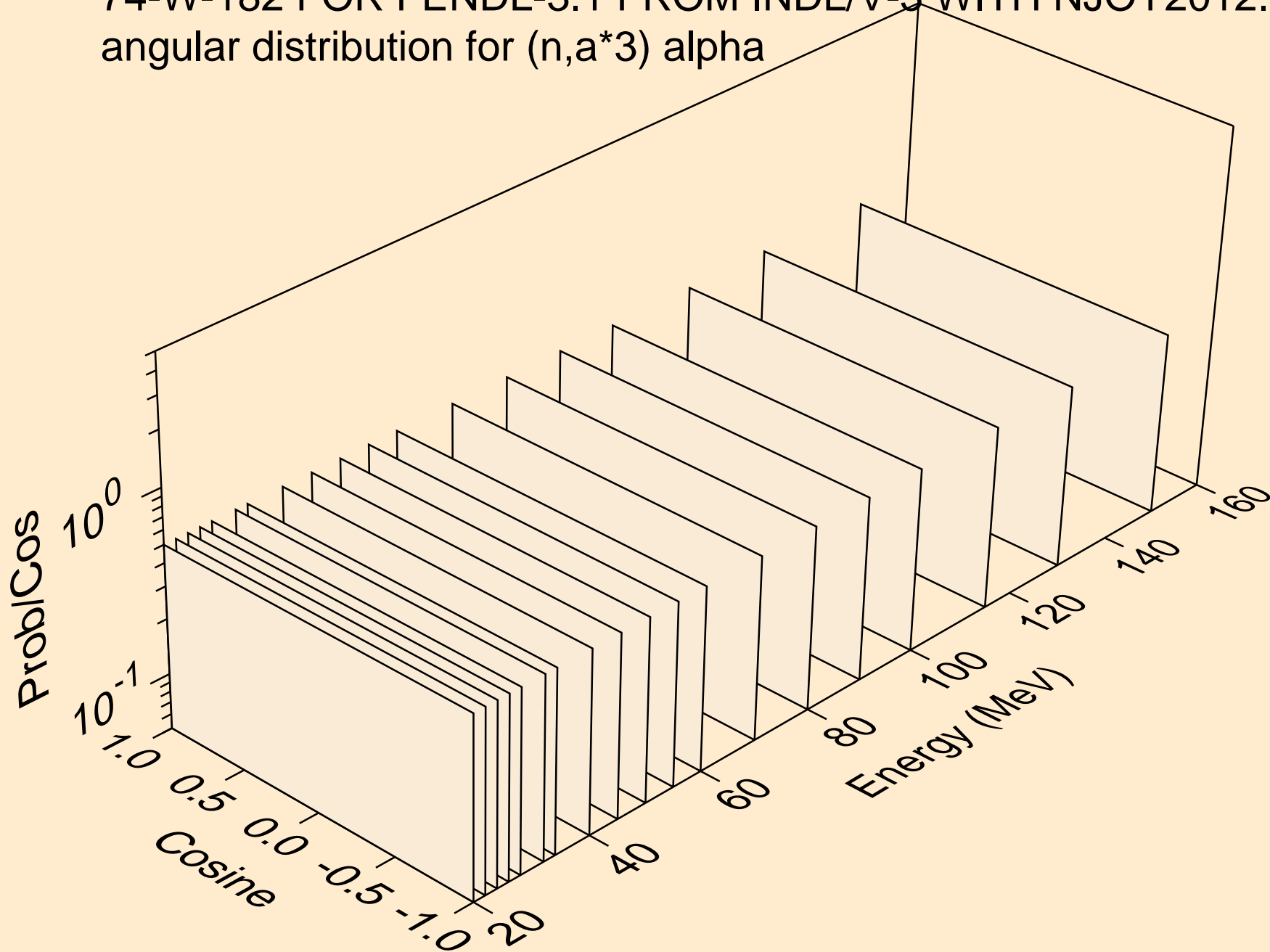

74-W-182 FOR FENDL-3.1 FROM INDL/V-3 WITH NJOY2012.50+ C
angular distribution for (n,a*4) alpha

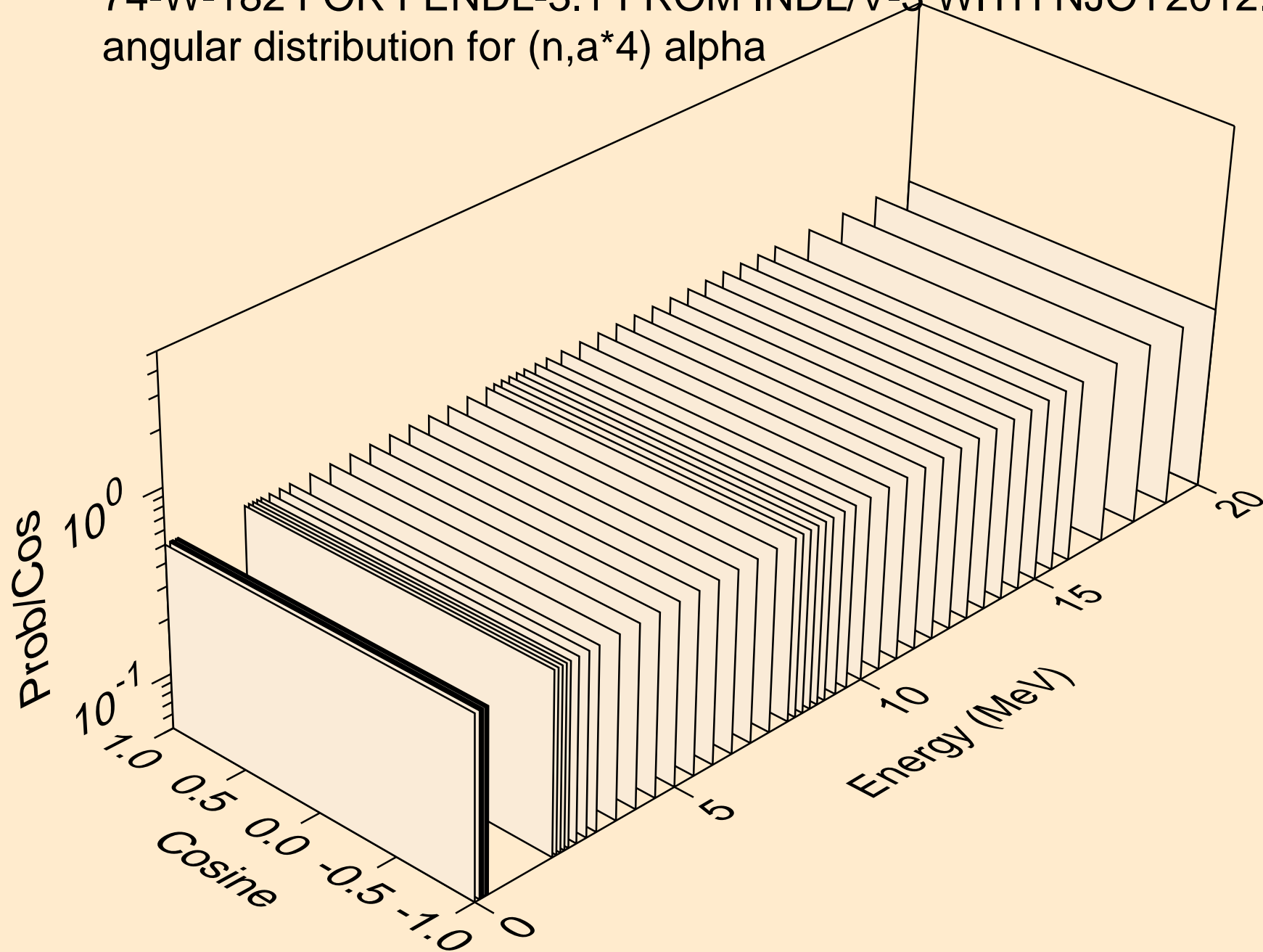

74-W-182 FOR FENDL-3.1 FROM INDL/V-3 WITH NJOY2012.50+ C
angular distribution for (n,a*4) alpha

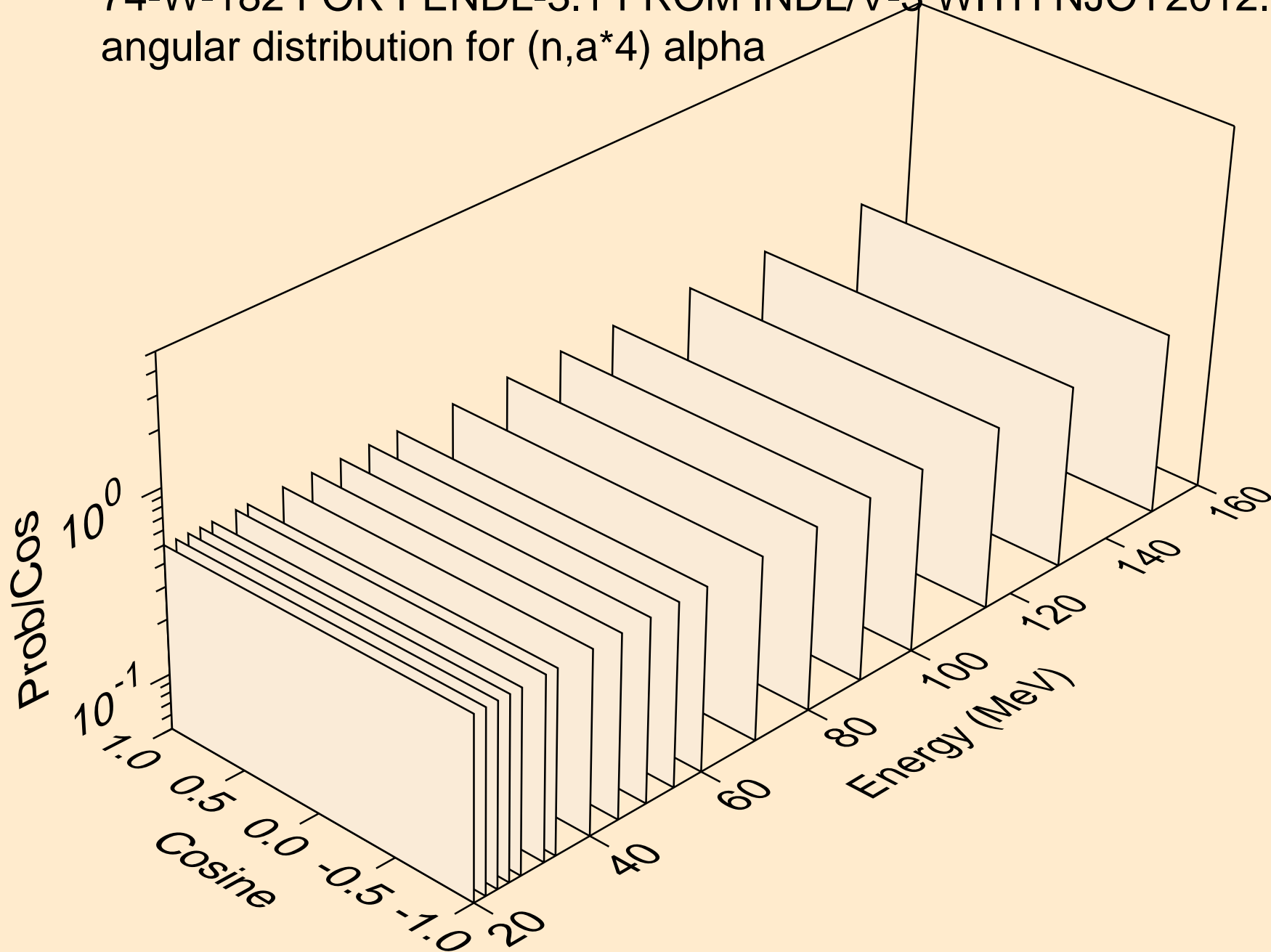

74-W-182 FOR FENDL-3.1 FROM INDL/V-3 WITH NJOY2012.50+ C
angular distribution for (n,a*5) alpha

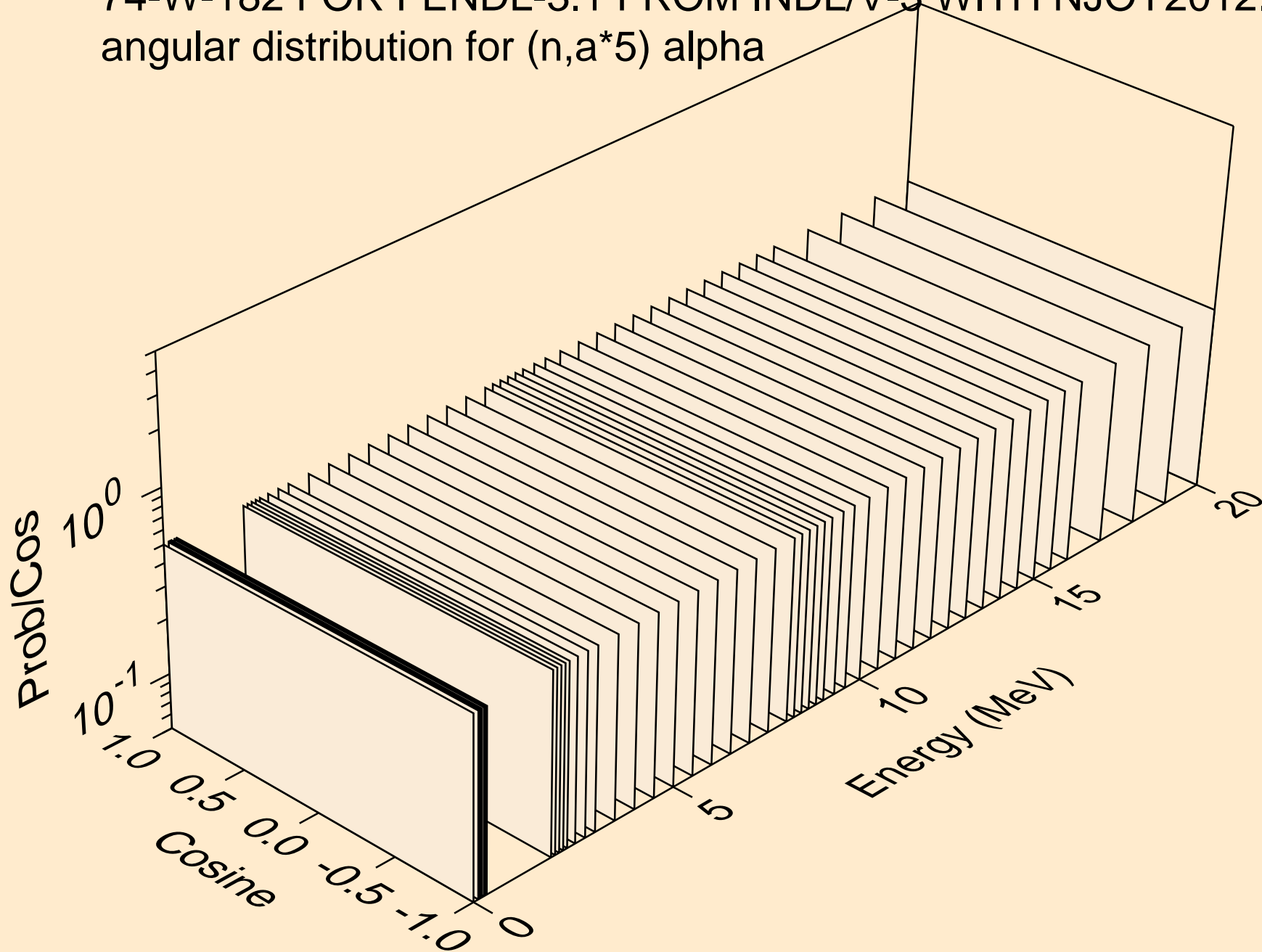

74-W-182 FOR FENDL-3.1 FROM INDL/V-3 WITH NJOY2012.50+ C
angular distribution for (n,a*5) alpha

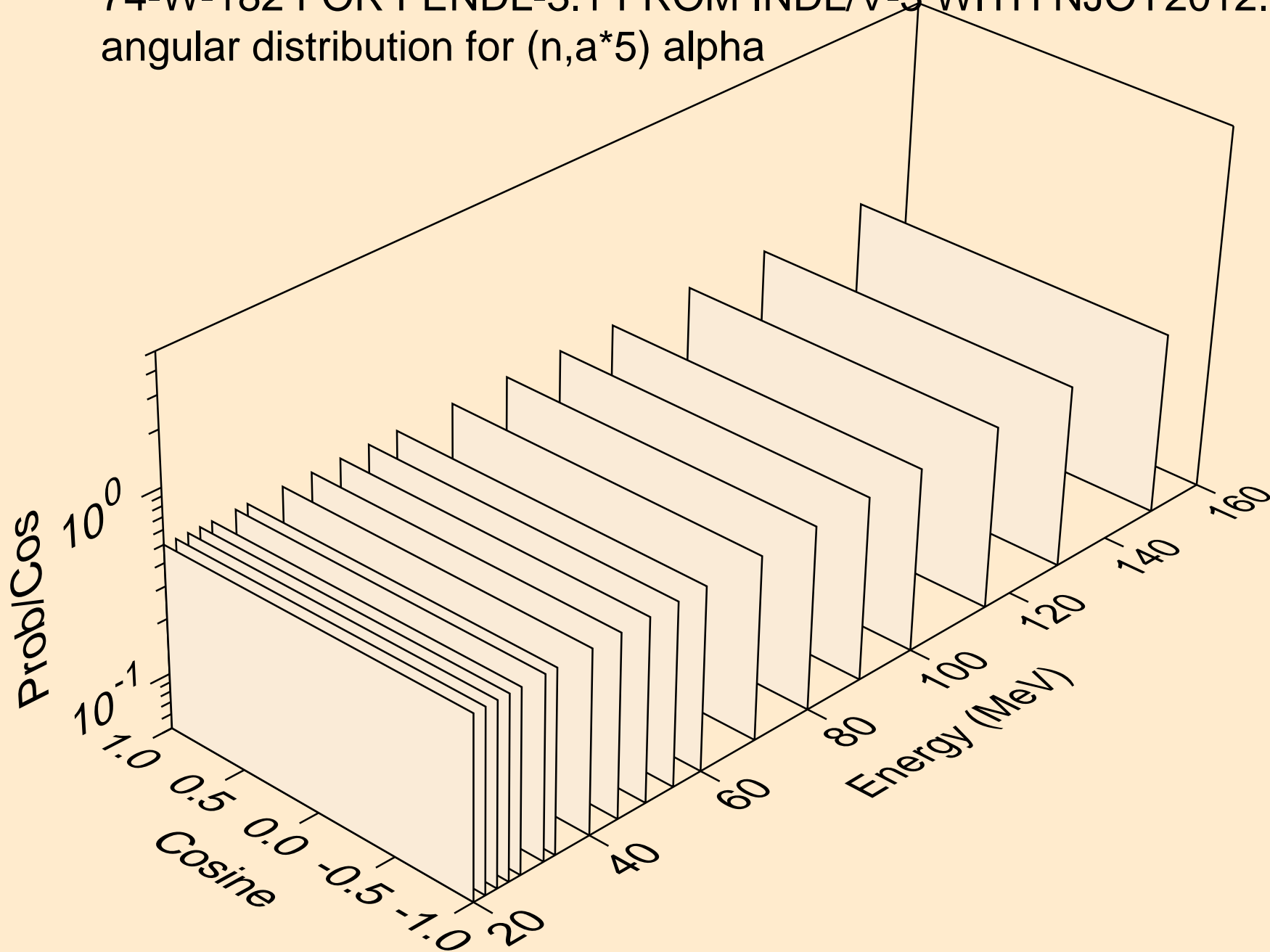

74-W-182 FOR FENDL-3.1 FROM INDL/V-3 WITH NJOY2012.50+ C
angular distribution for (n,a*6) alpha

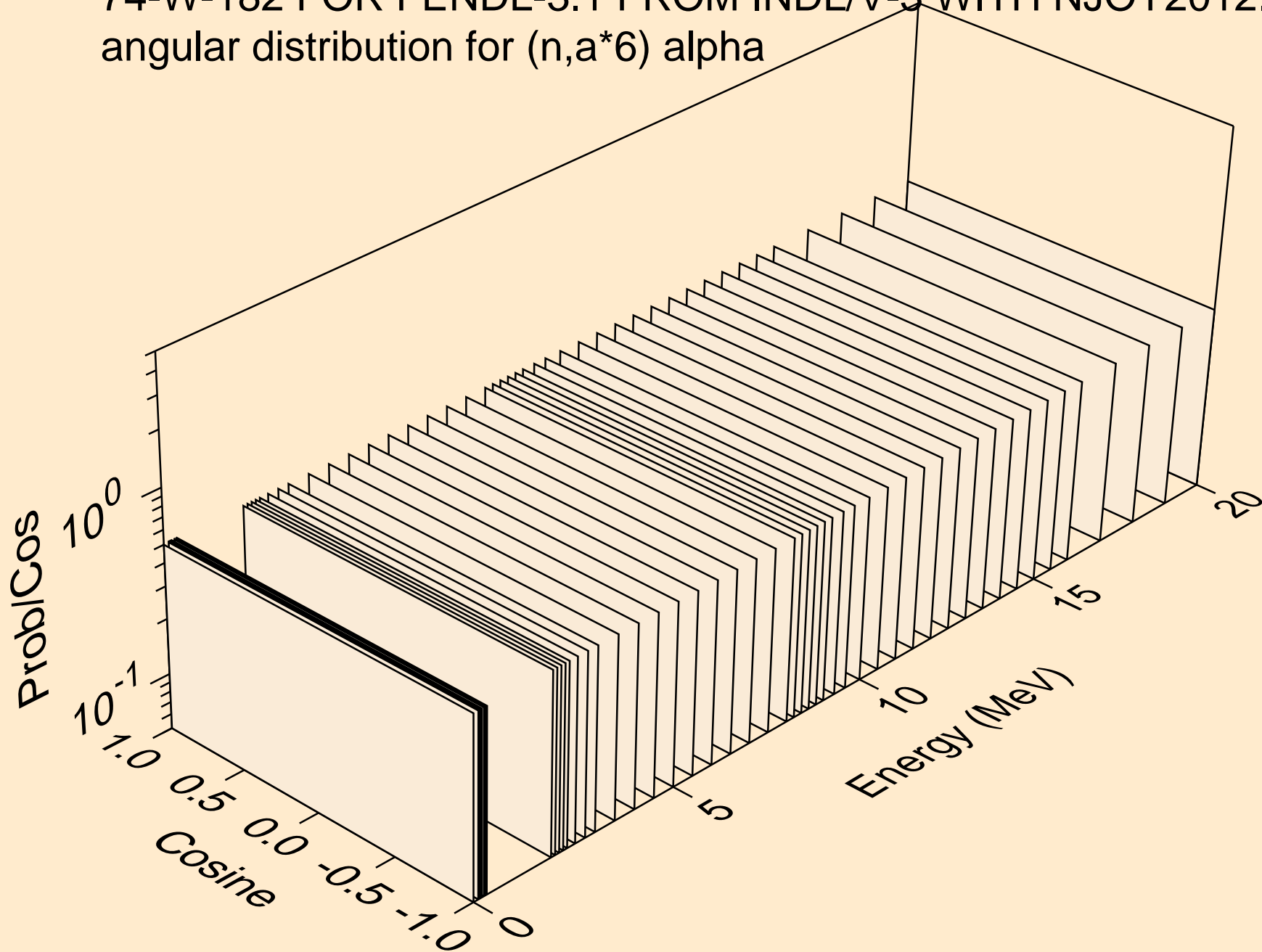

74-W-182 FOR FENDL-3.1 FROM INDL/V-3 WITH NJOY2012.50+ C
angular distribution for (n,a*6) alpha

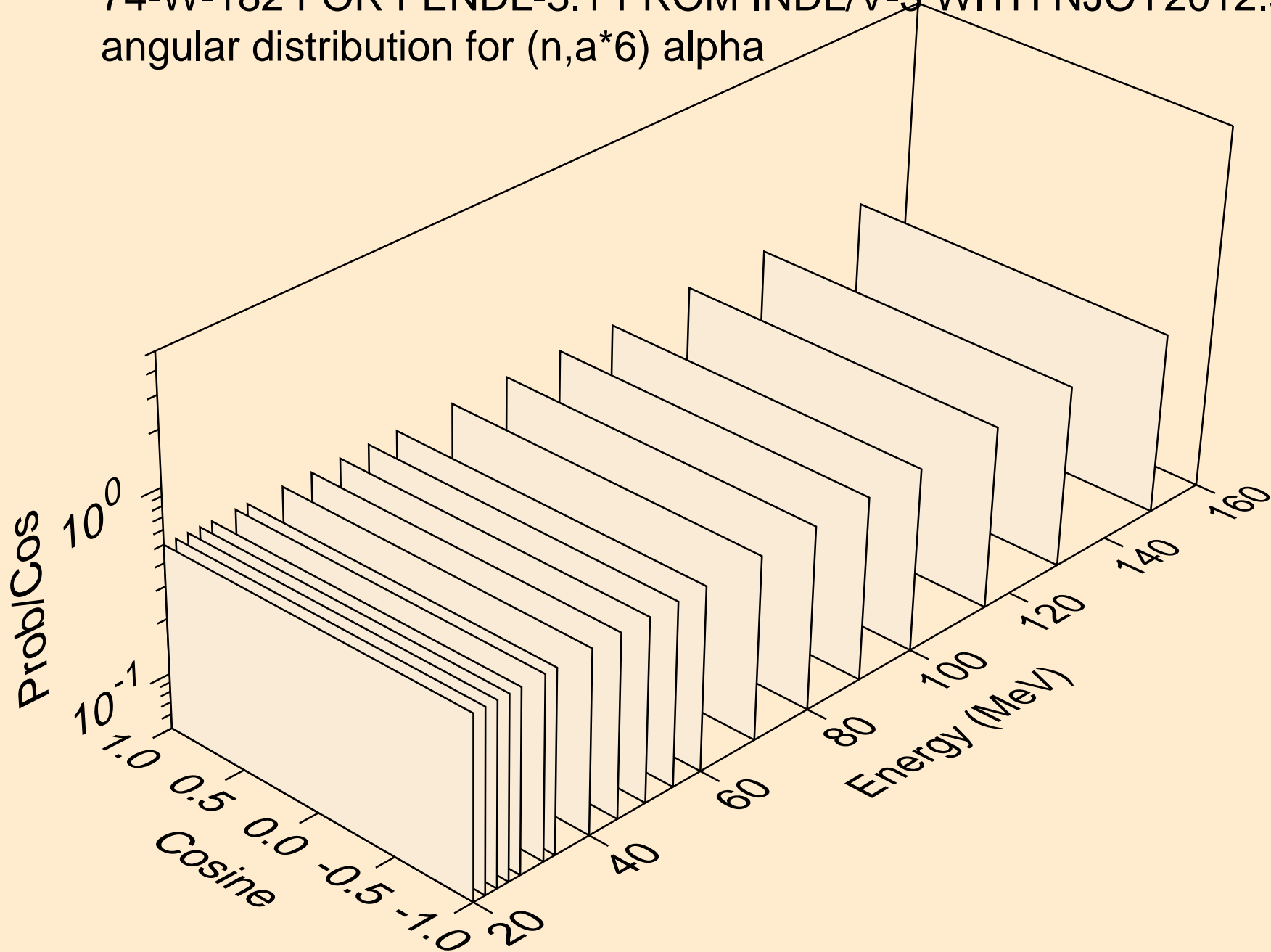

74-W-182 FOR FENDL-3.1 FROM INDLV-3 WITH NJOY2012.50+ C
alphas from (n,a*c)

