

7-N-14 FOR FENDL-3.2 FROM FENDL-3.2 BY NJOY2016.60+ ON D

Principal cross sections

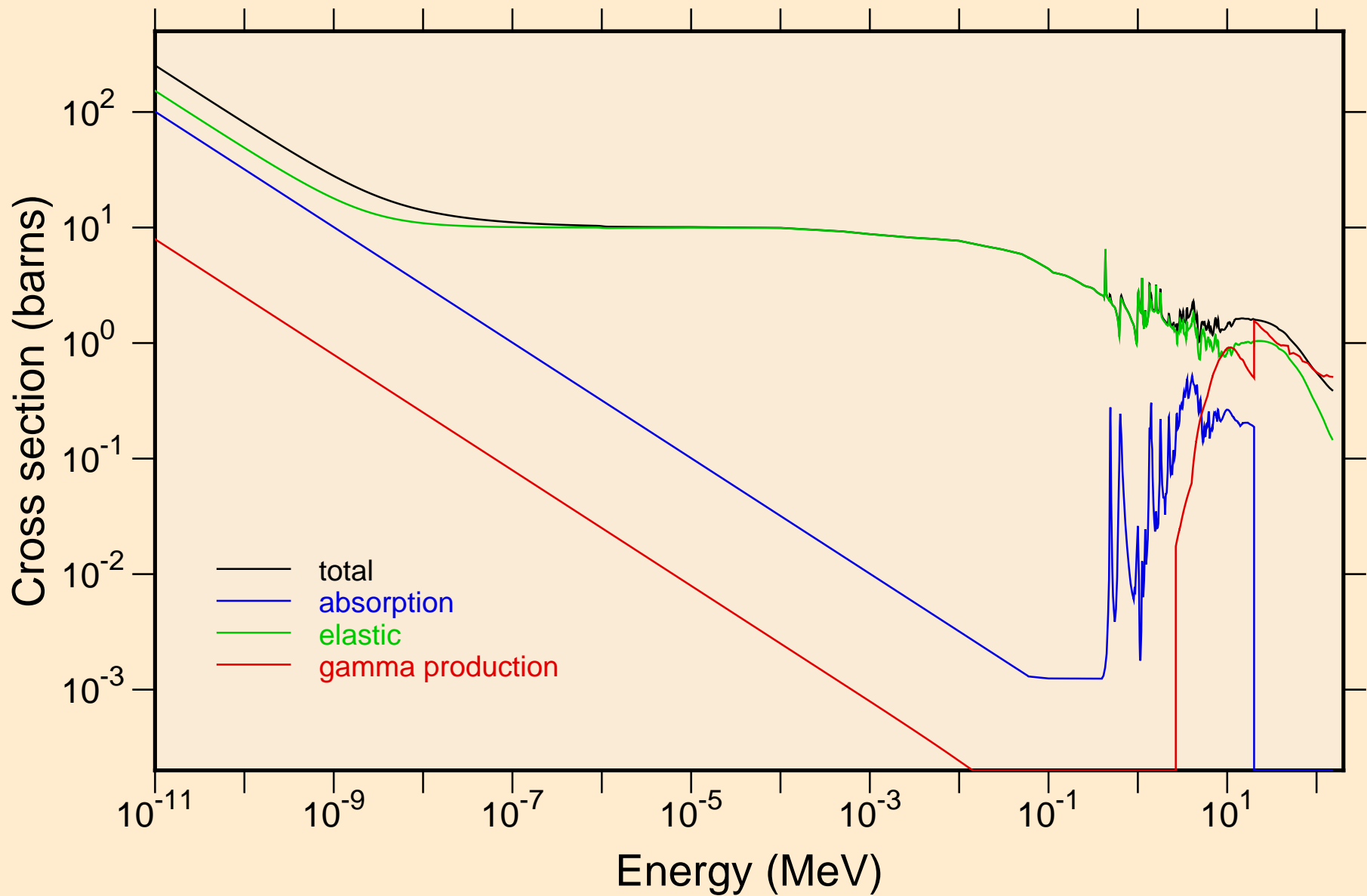

7-N-14 FOR FENDL-3.2 FROM FENDL-3.2 BY NJOY2016.60+ ON D
resonance total cross section

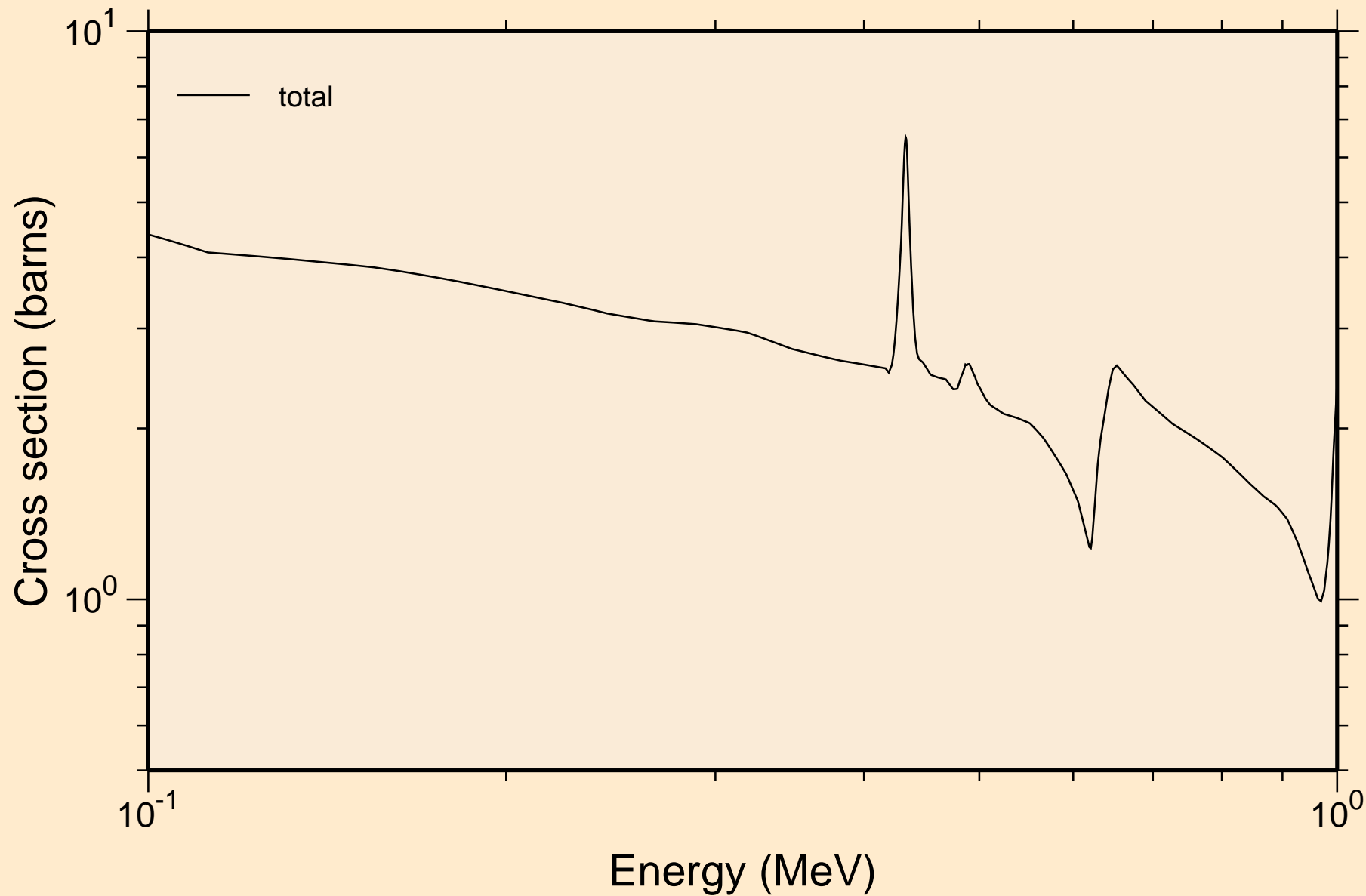

7-N-14 FOR FENDL-3.2 FROM FENDL-3.2 BY NJOY2016.60+ ON D
resonance total cross section

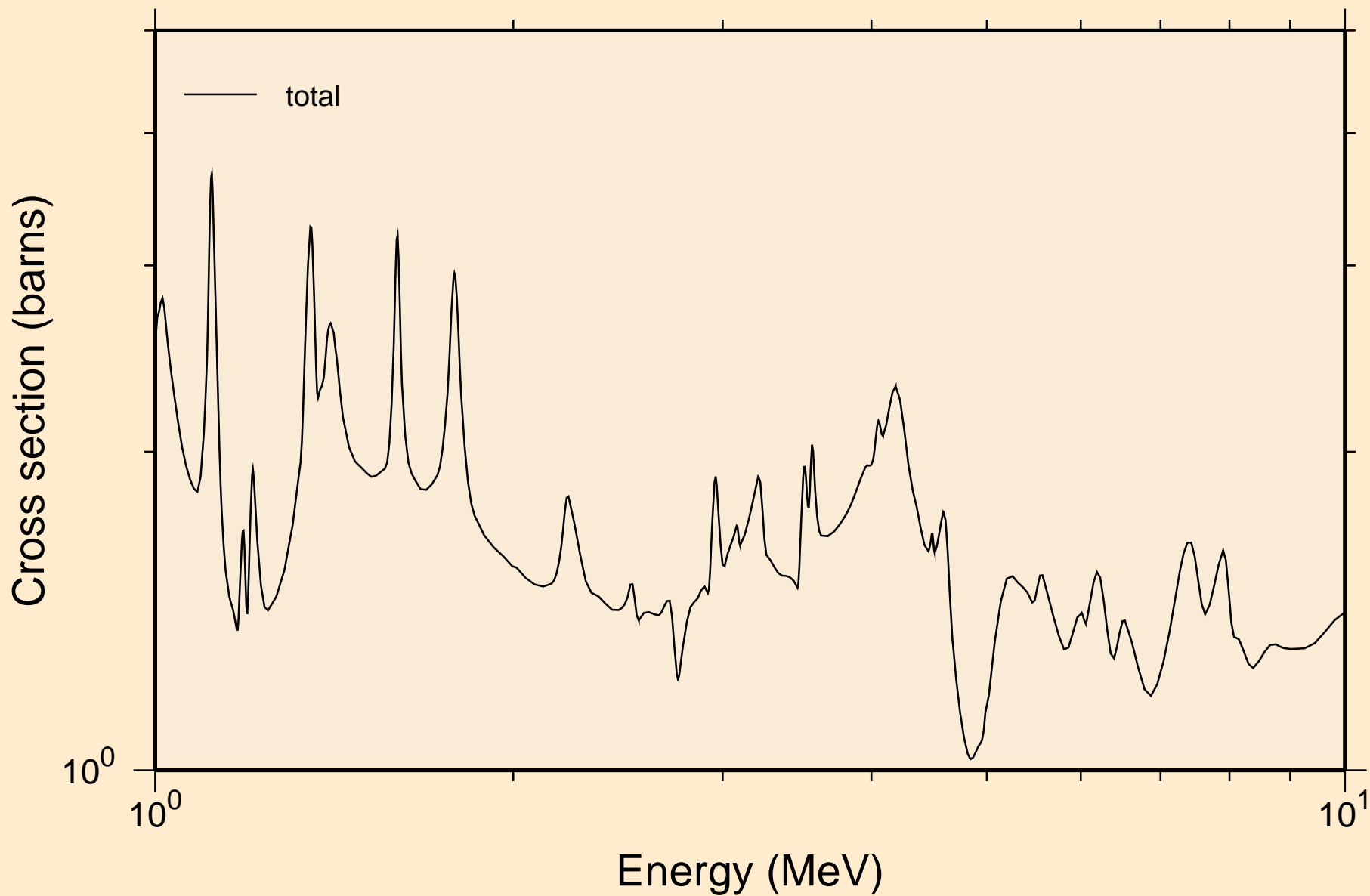

7-N-14 FOR FENDL-3.2 FROM FENDL-3.2 BY NJOY2016.60+ ON D
resonance absorption cross sections

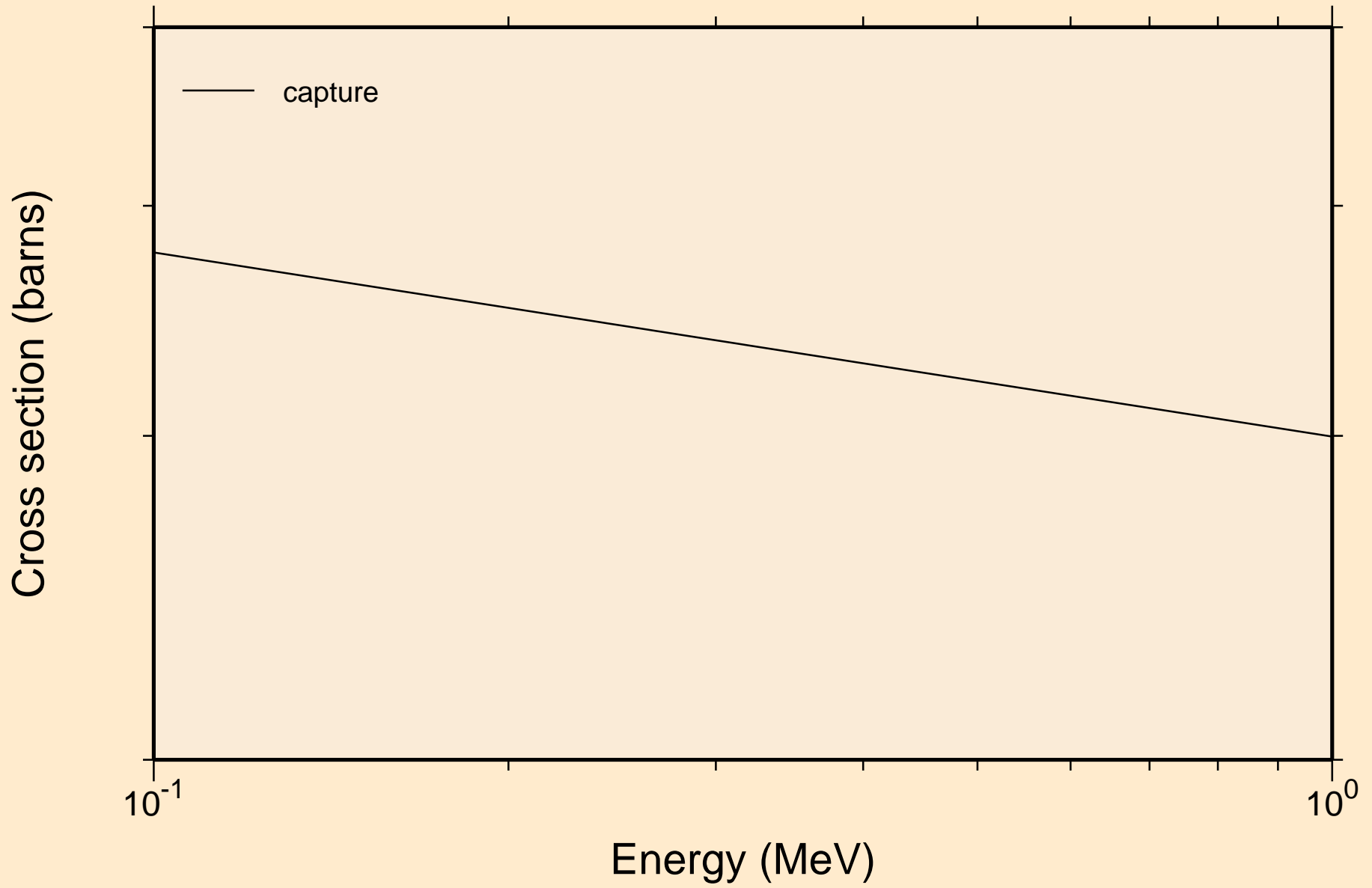

7-N-14 FOR FENDL-3.2 FROM FENDL-3.2 BY NJOY2016.60+ ON D
resonance absorption cross sections

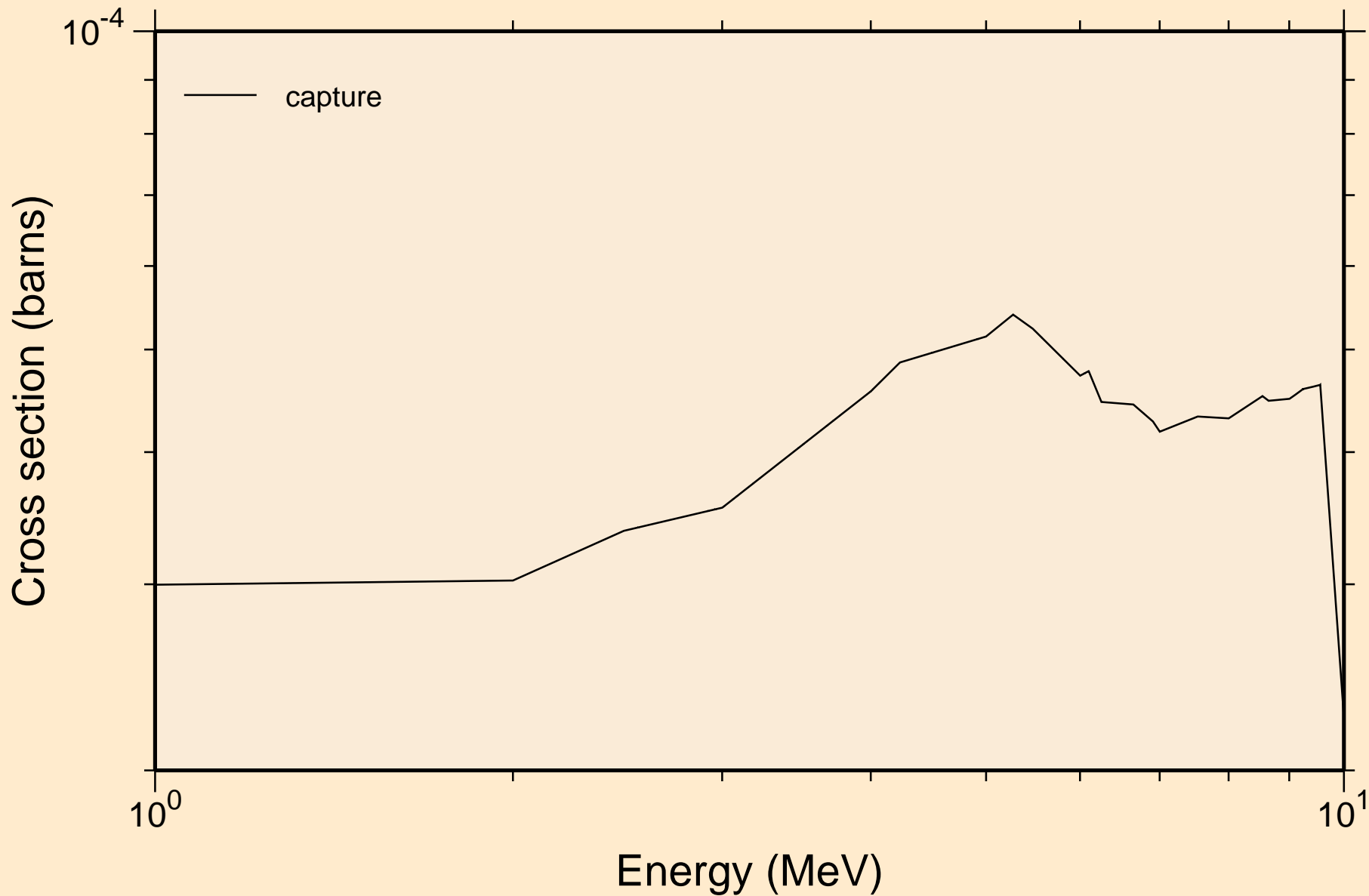

7-N-14 FOR FENDL-3.2 FROM FENDL-3.2 BY NJOY2016.60+ ON D Heating

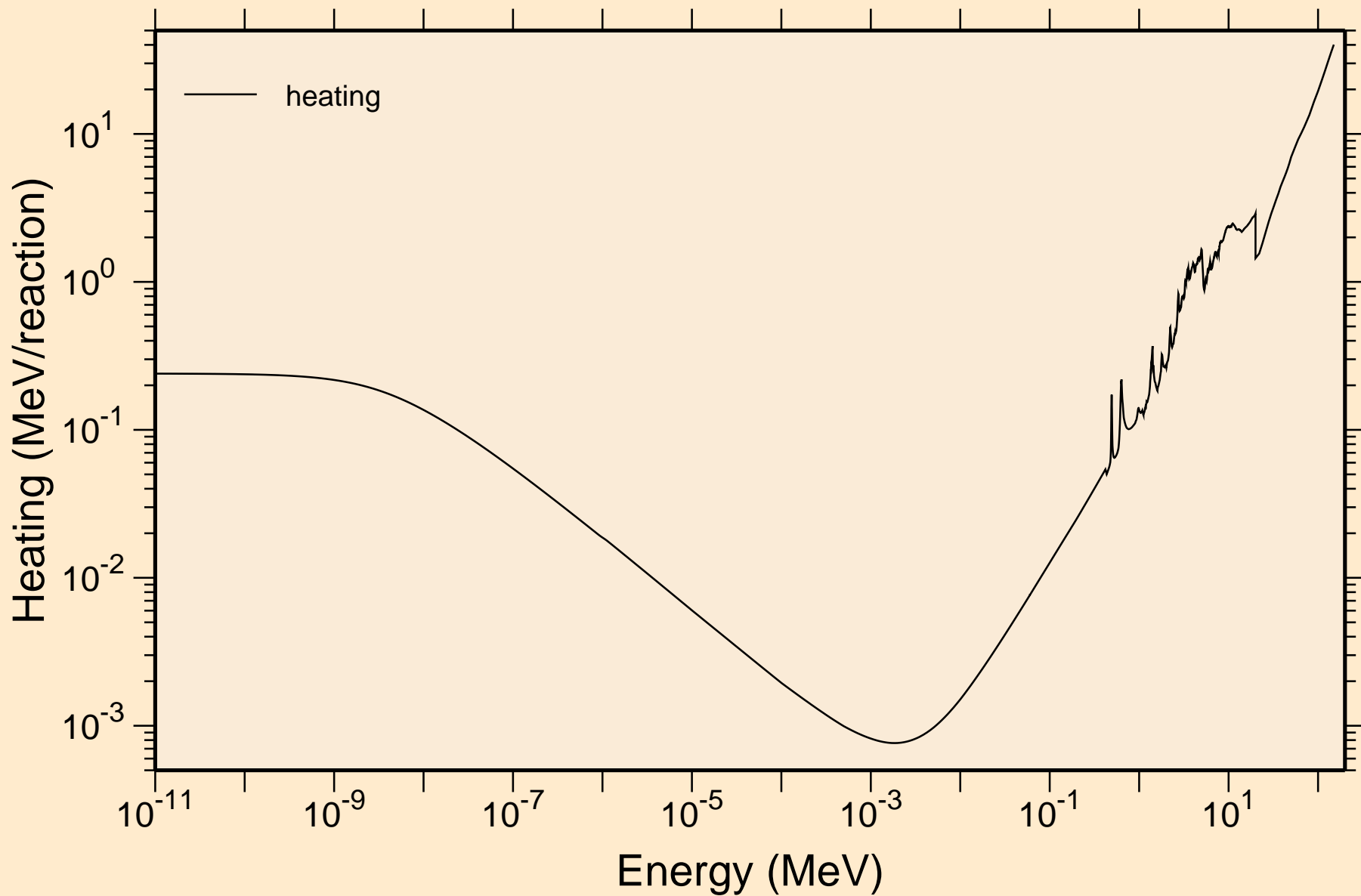

7-N-14 FOR FENDL-3.2 FROM FENDL-3.2 BY NJOY2016.60+ ON D Damage

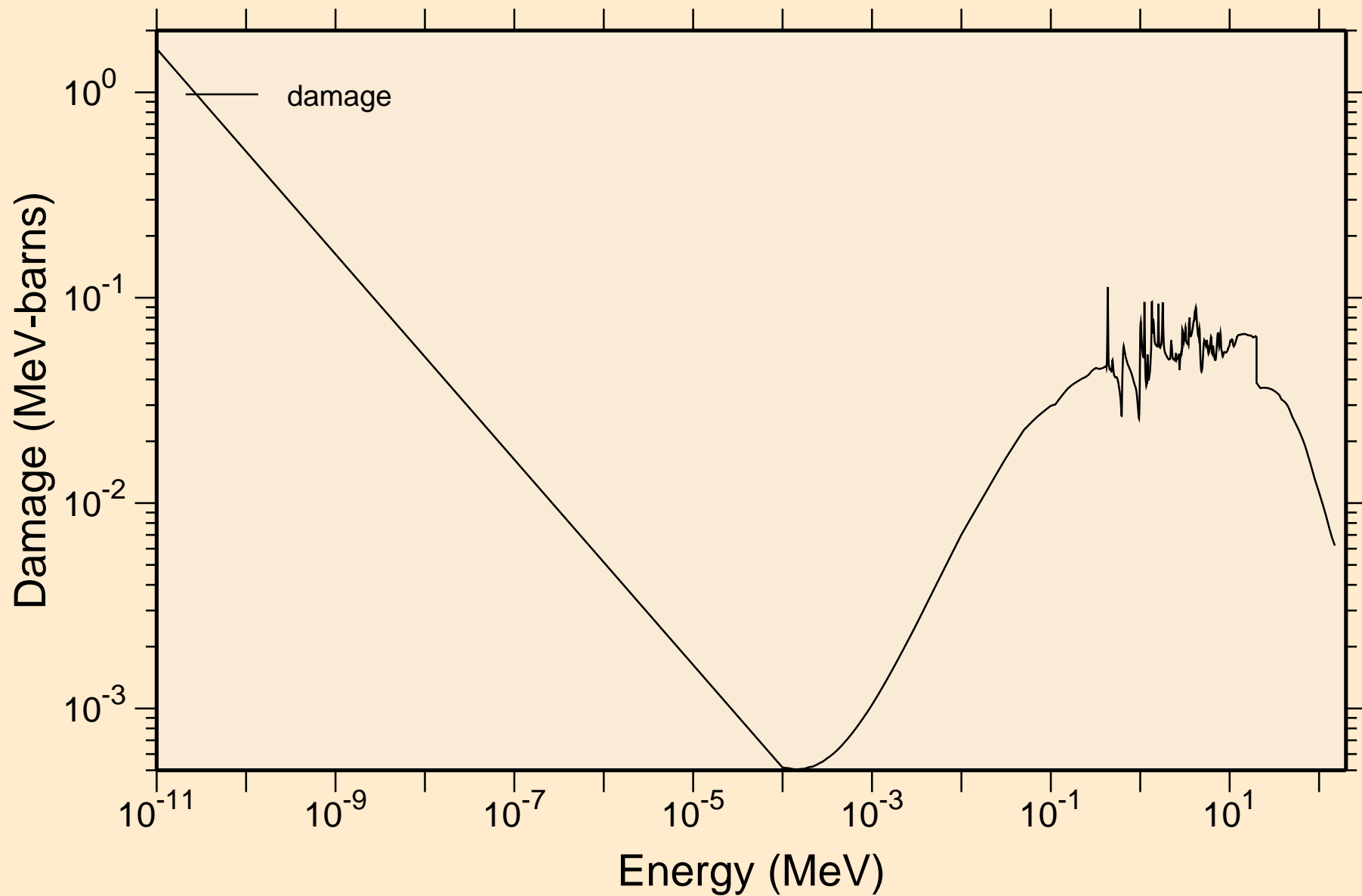

7-N-14 FOR FENDL-3.2 FROM FENDL-3.2 BY NJOY2016.60+ ON D
Non-threshold reactions

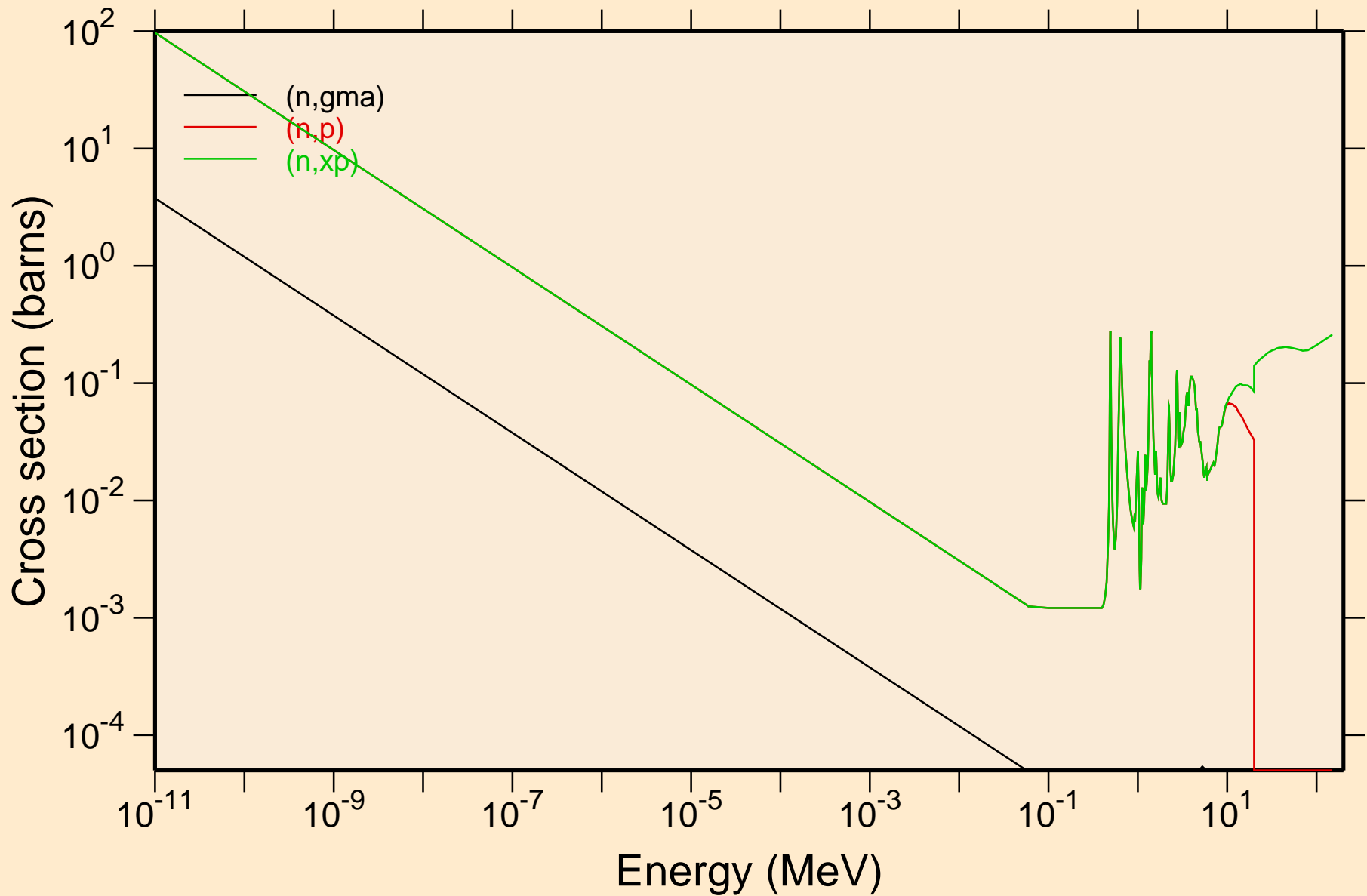

7-N-14 FOR FENDL-3.2 FROM FENDL-3.2 BY NJOY2016.60+ ON D

Principal cross sections

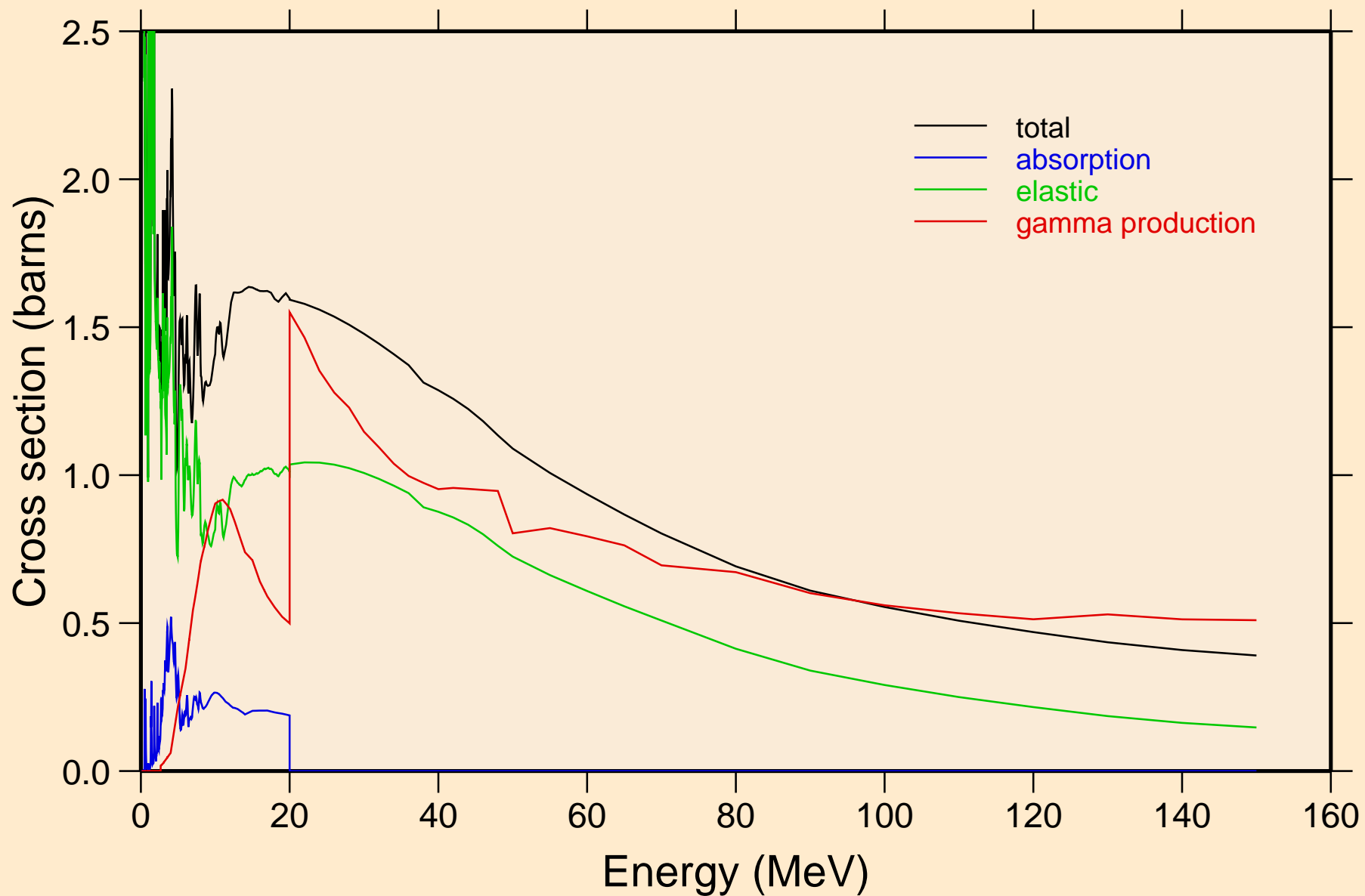

7-N-14 FOR FENDL-3.2 FROM FENDL-3.2 BY NJOY2016.60+ ON D Heating

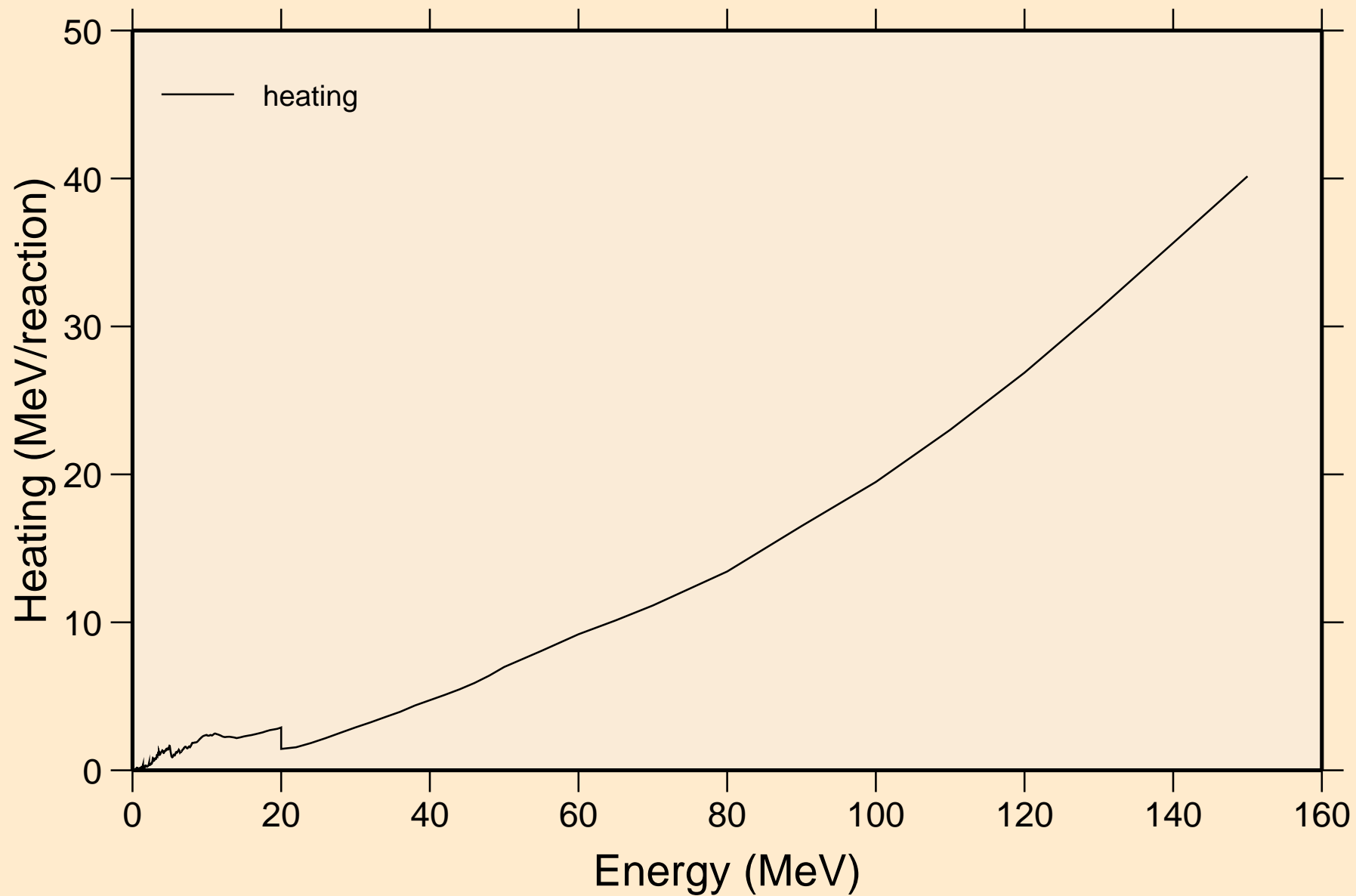

7-N-14 FOR FENDL-3.2 FROM FENDL-3.2 BY NJOY2016.60+ ON D Damage

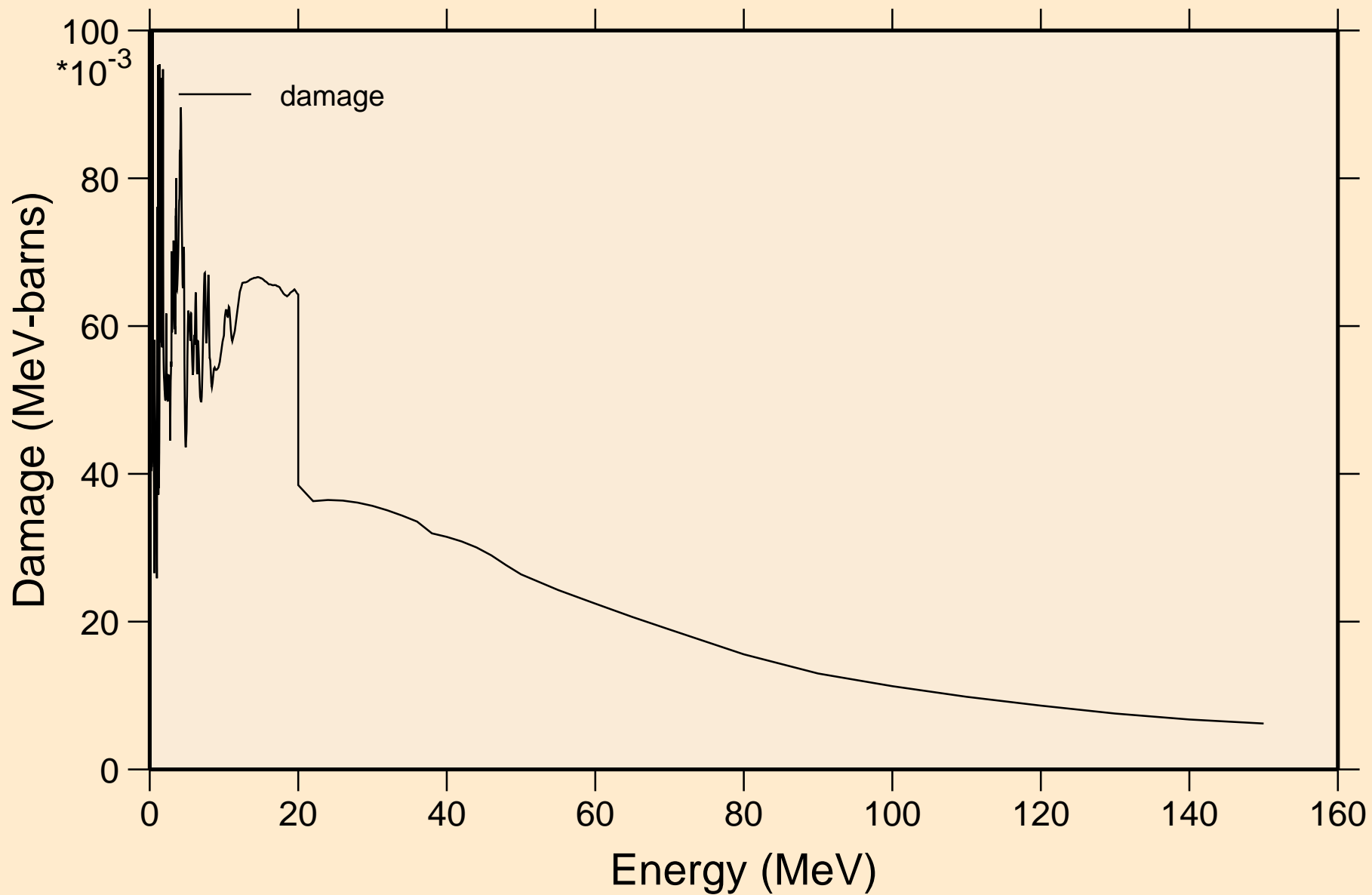

7-N-14 FOR FENDL-3.2 FROM FENDL-3.2 BY NJOY2016.60+ ON D

Non-threshold reactions

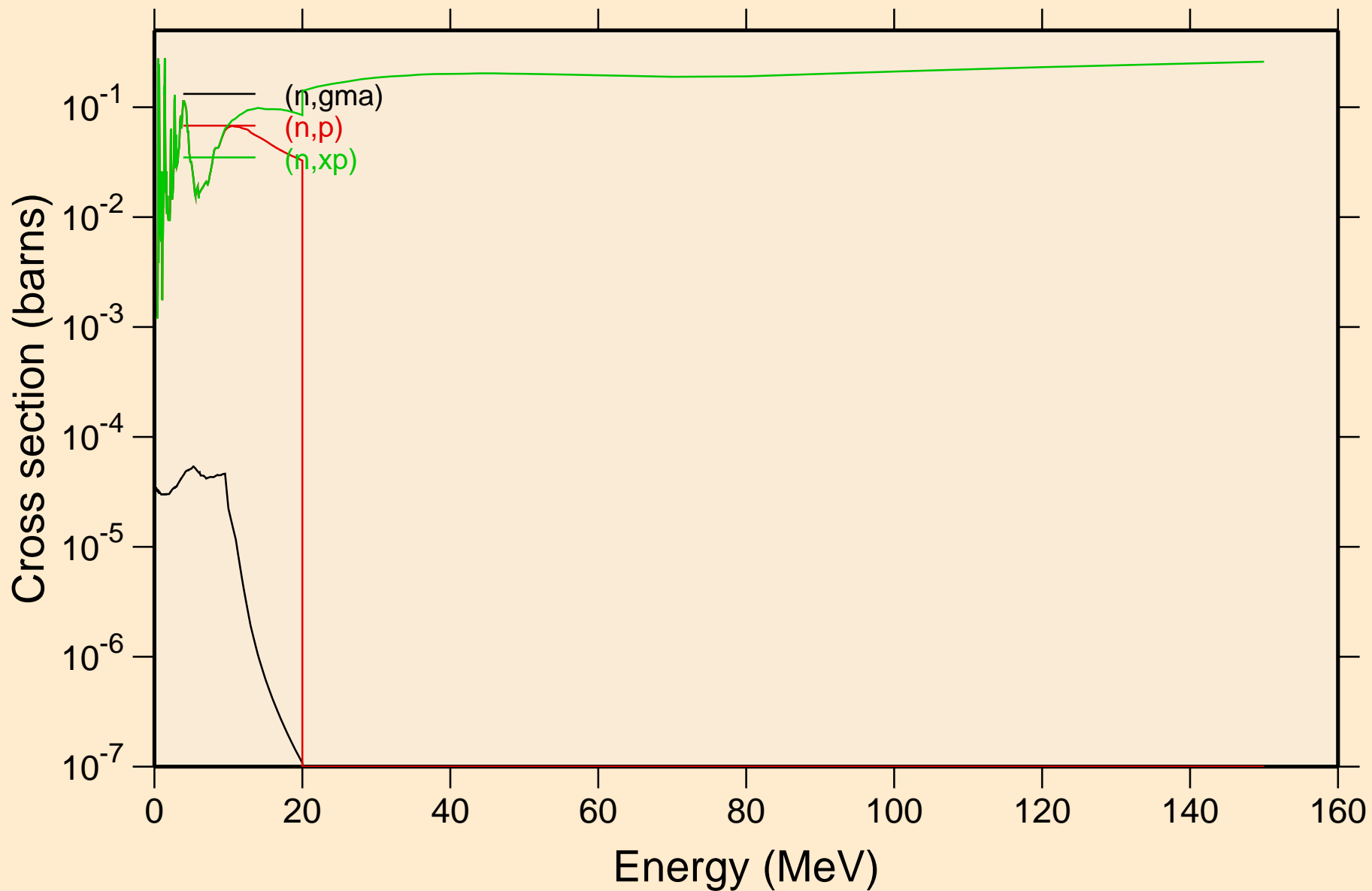

7-N-14 FOR FENDL-3.2 FROM FENDL-3.2 BY NJOY2016.60+ ON D Inelastic levels

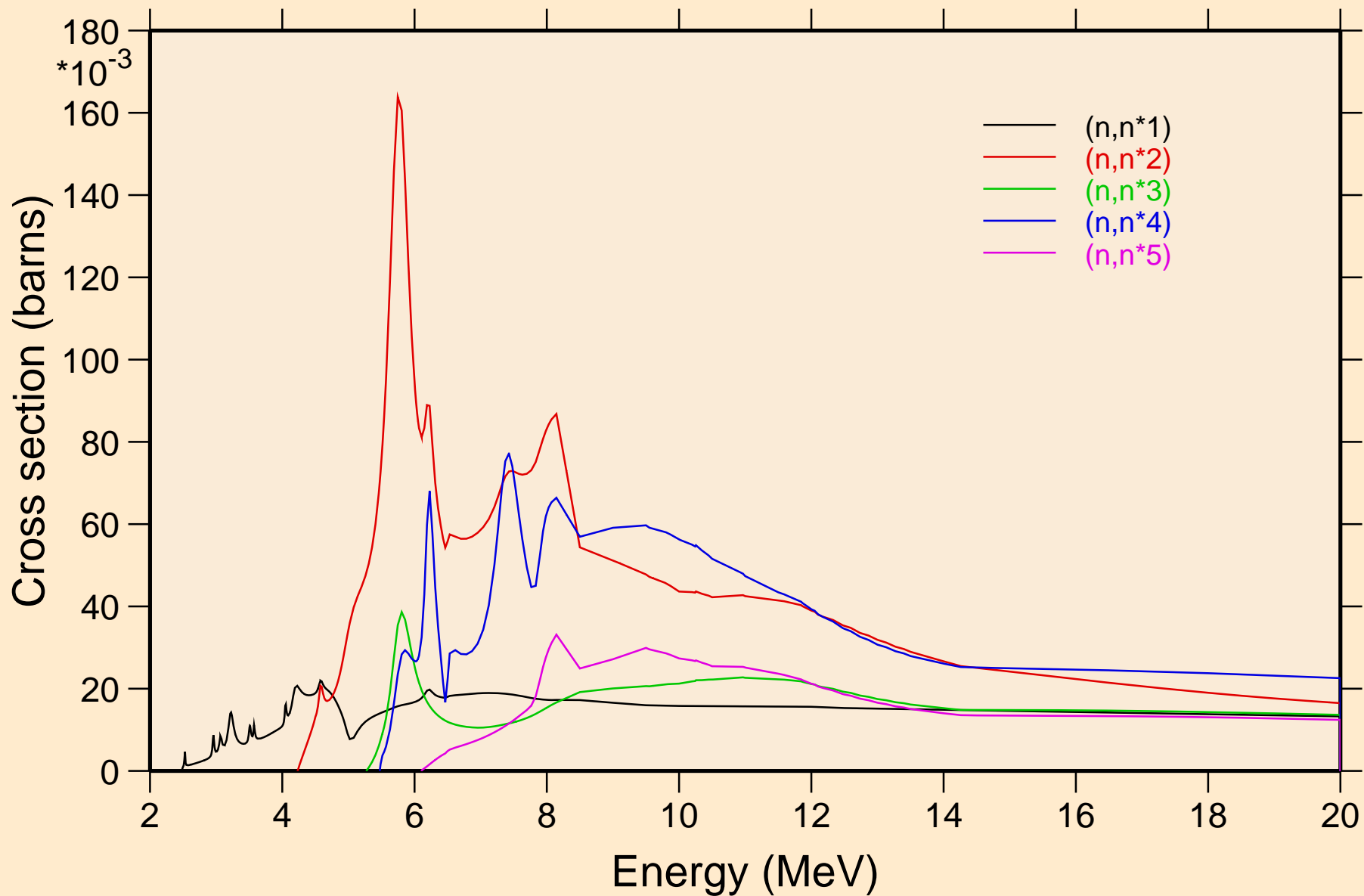

7-N-14 FOR FENDL-3.2 FROM FENDL-3.2 BY NJOY2016.60+ ON D Inelastic levels

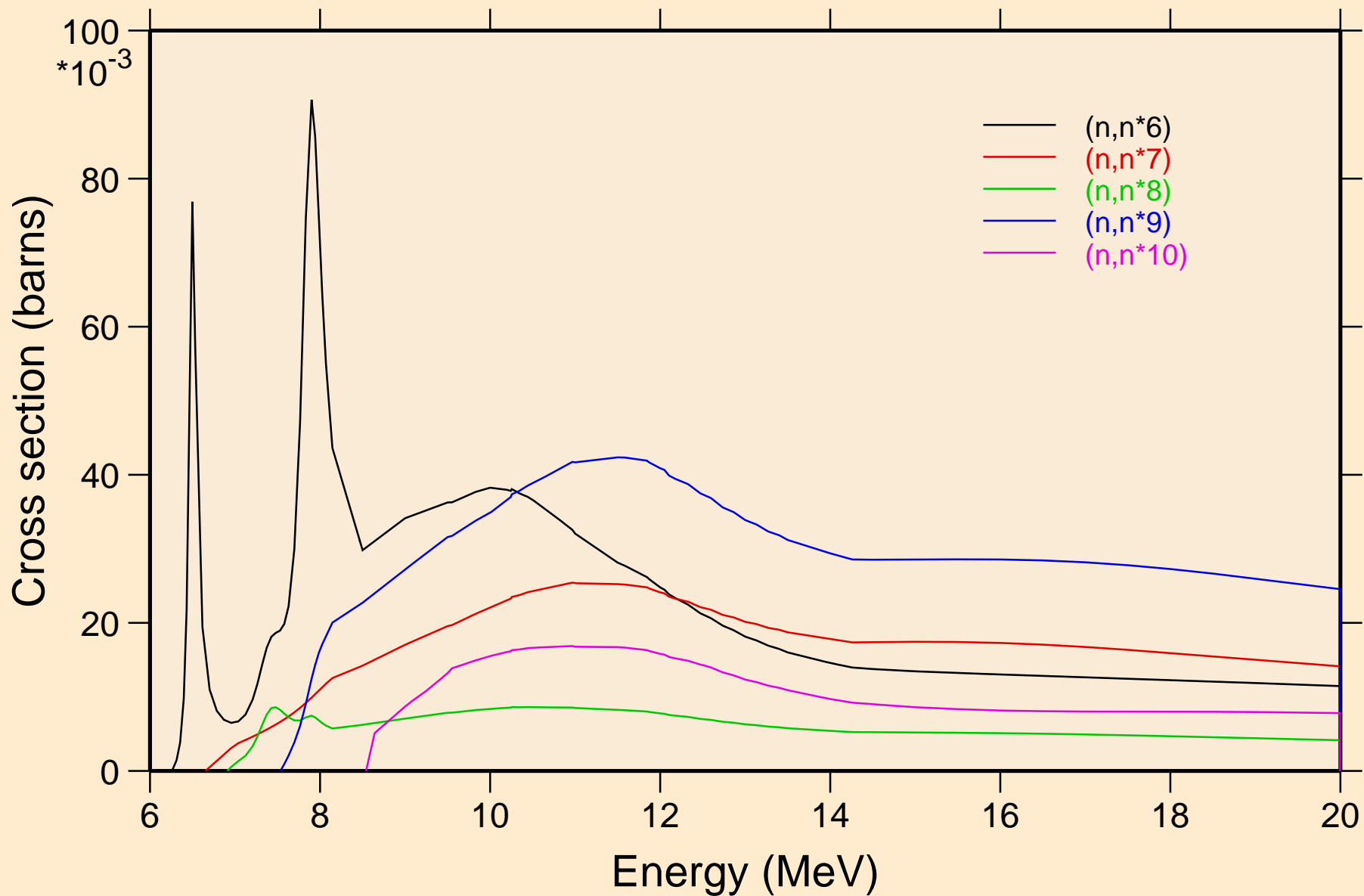

7-N-14 FOR FENDL-3.2 FROM FENDL-3.2 BY NJOY2016.60+ ON D Inelastic levels

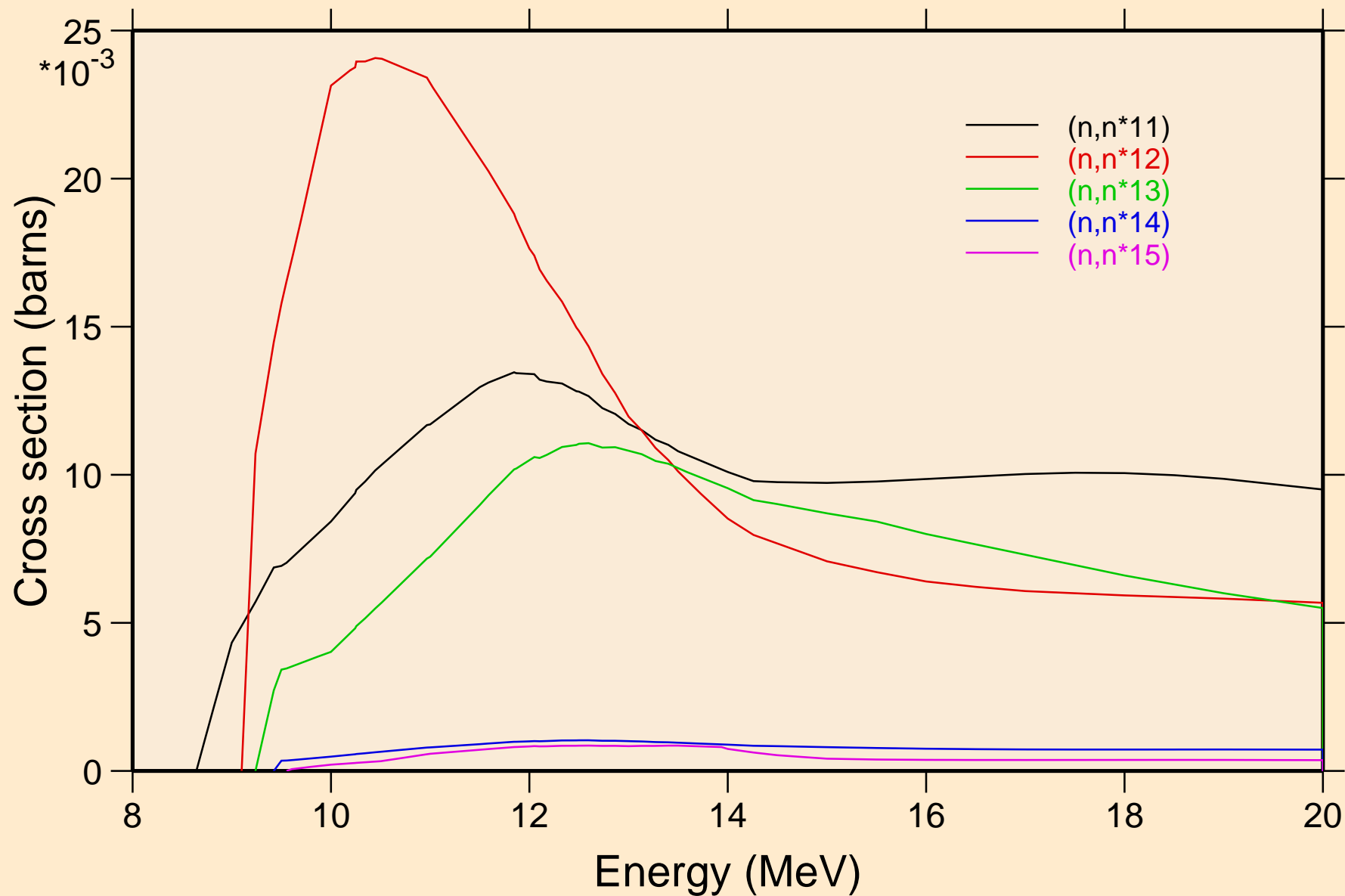

7-N-14 FOR FENDL-3.2 FROM FENDL-3.2 BY NJOY2016.60+ ON D Inelastic levels

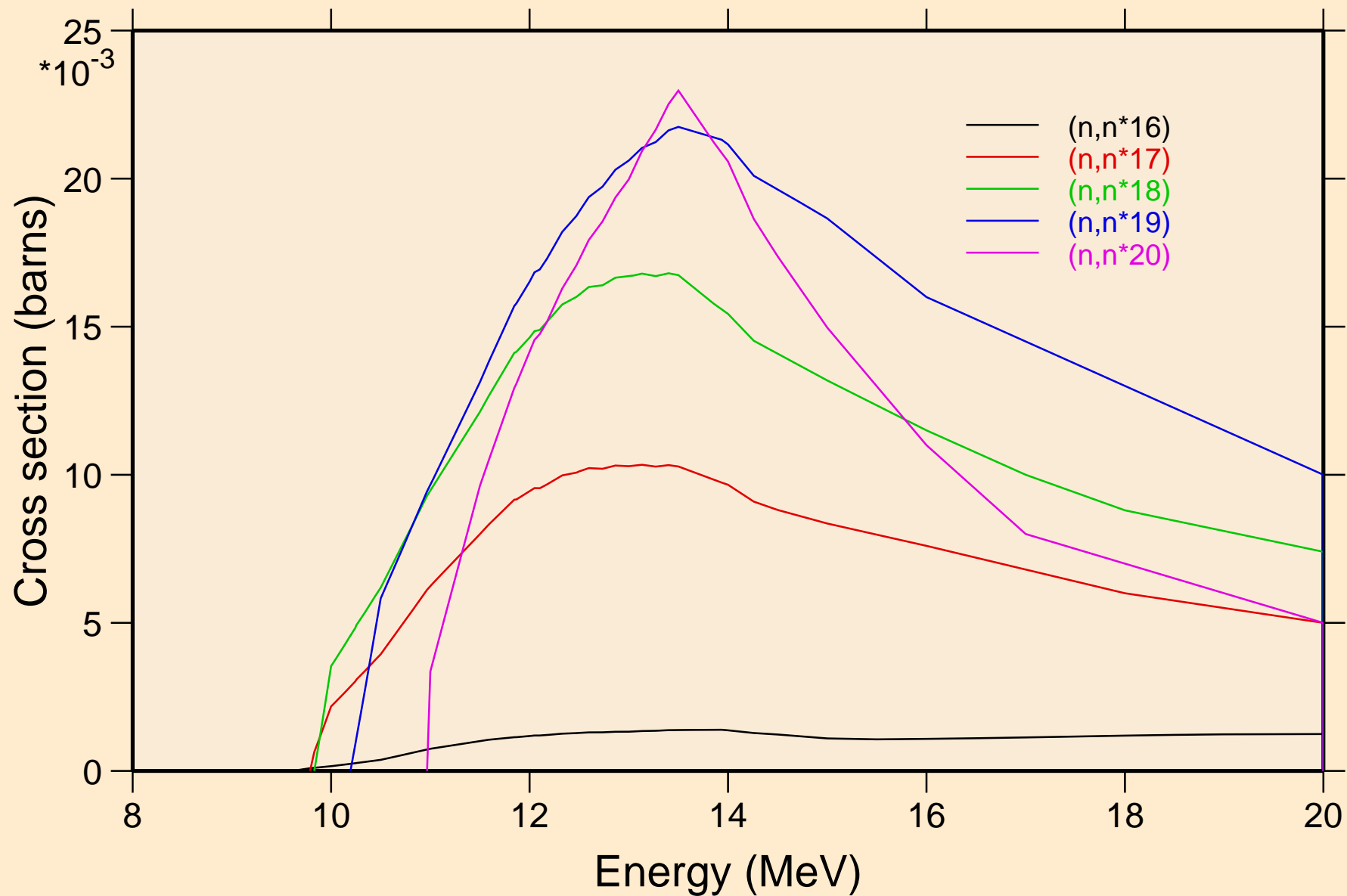

7-N-14 FOR FENDL-3.2 FROM FENDL-3.2 BY NJOY2016.60+ ON D
Inelastic levels

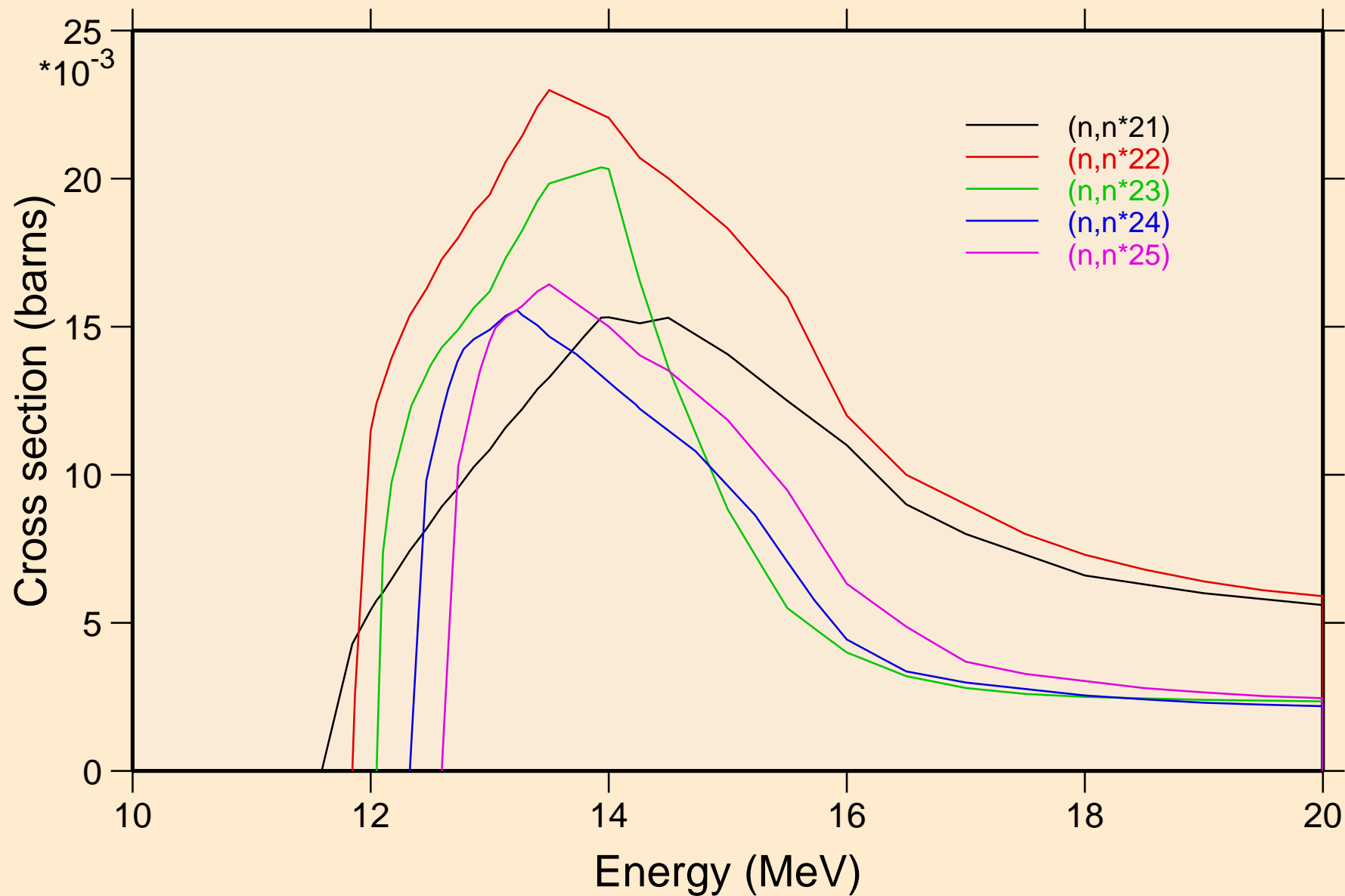

7-N-14 FOR FENDL-3.2 FROM FENDL-3.2 BY NJOY2016.60+ ON D Inelastic levels

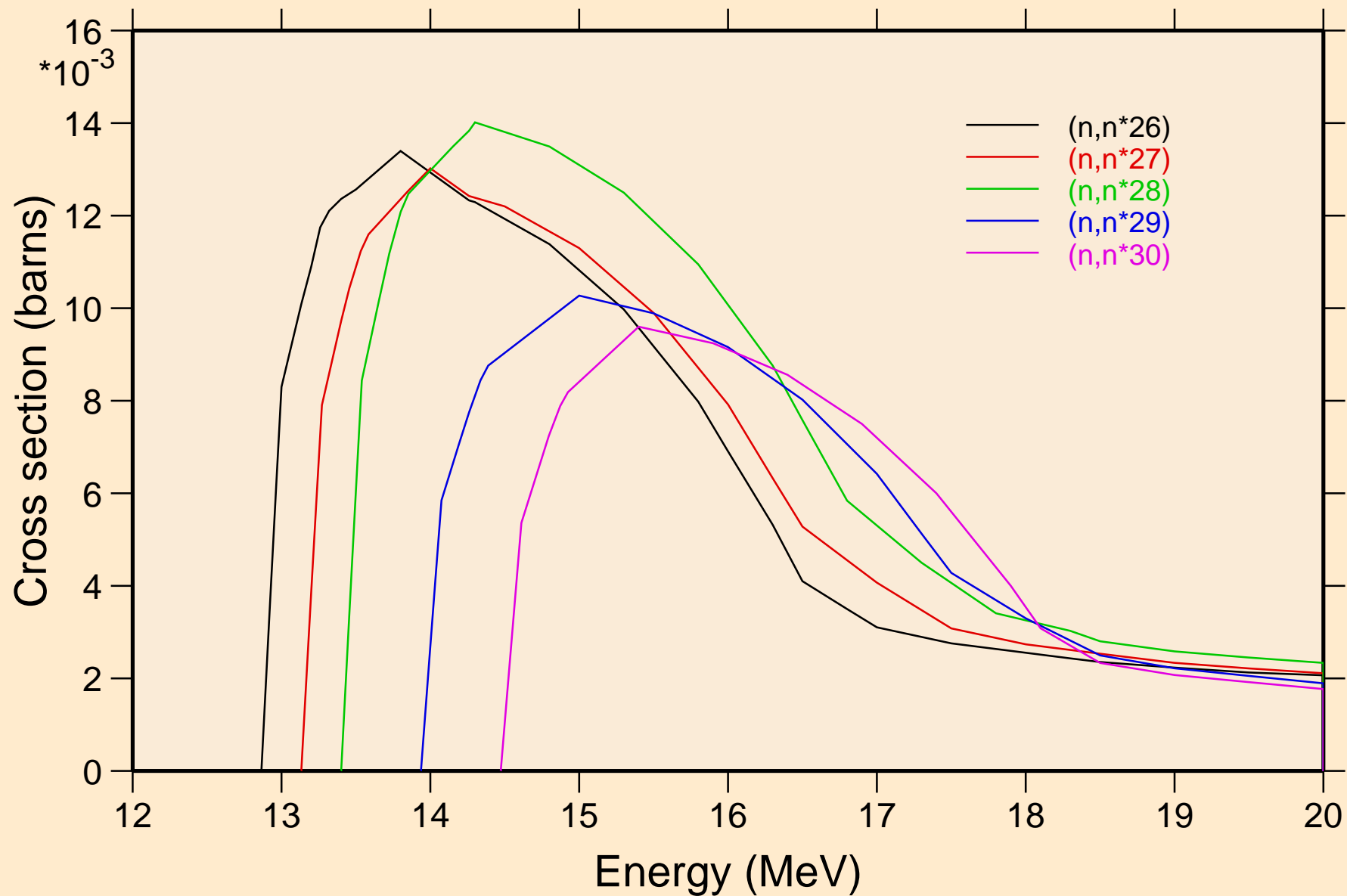

7-N-14 FOR FENDL-3.2 FROM FENDL-3.2 BY NJOY2016.60+ ON D
Inelastic levels

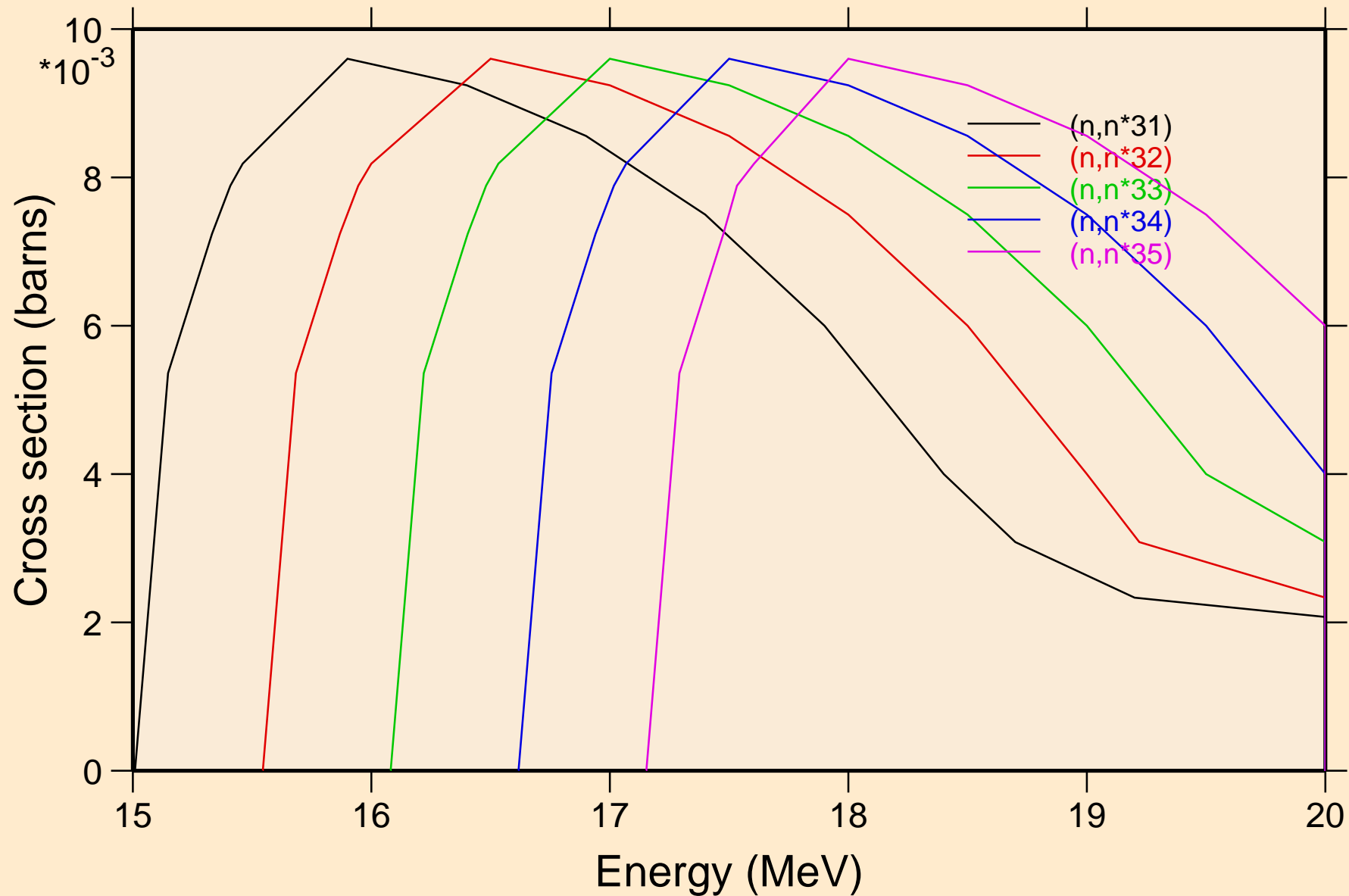

7-N-14 FOR FENDL-3.2 FROM FENDL-3.2 BY NJOY2016.60+ ON D Inelastic levels

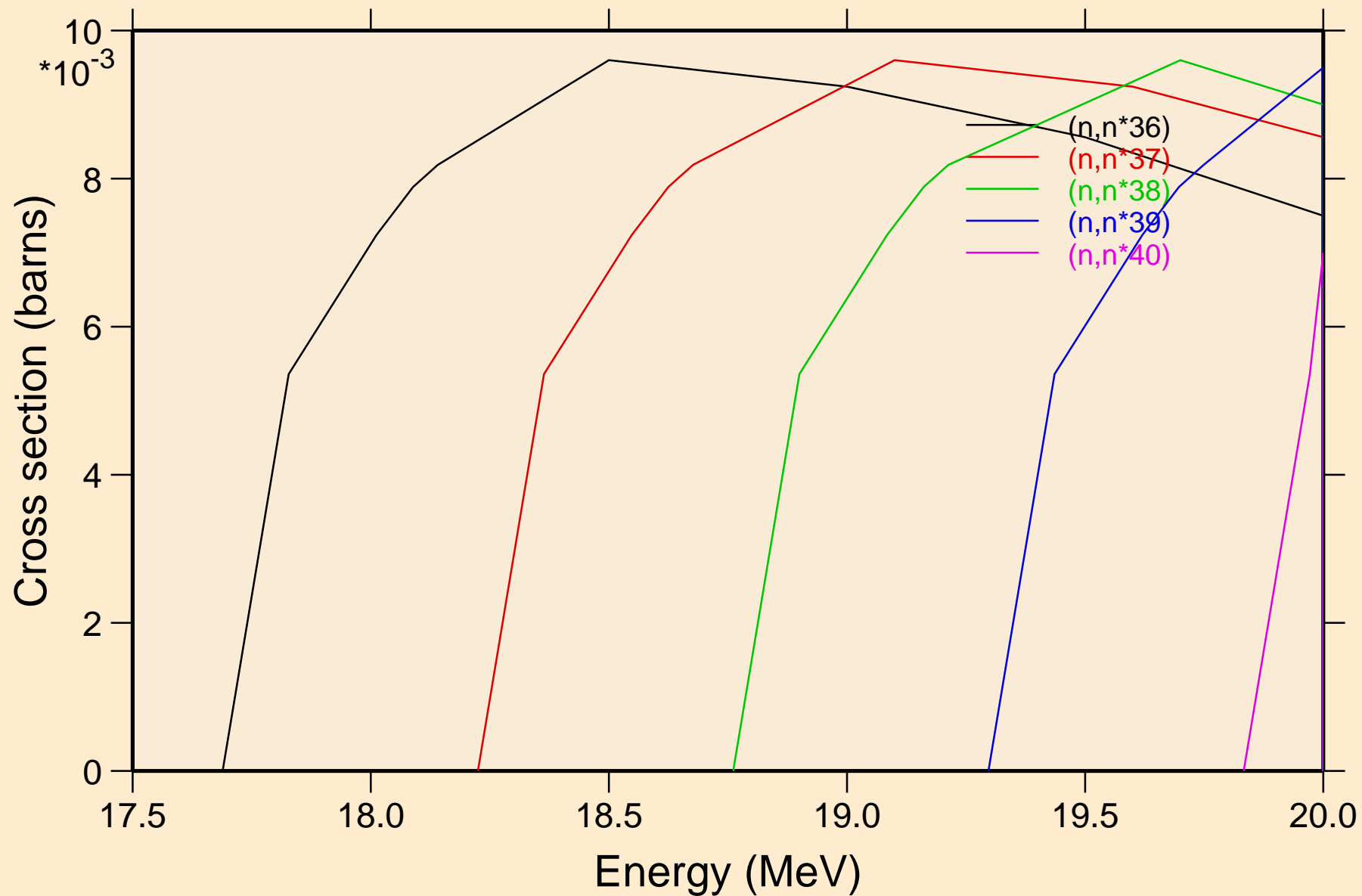

7-N-14 FOR FENDL-3.2 FROM FENDL-3.2 BY NJOY2016.60+ ON D Threshold reactions

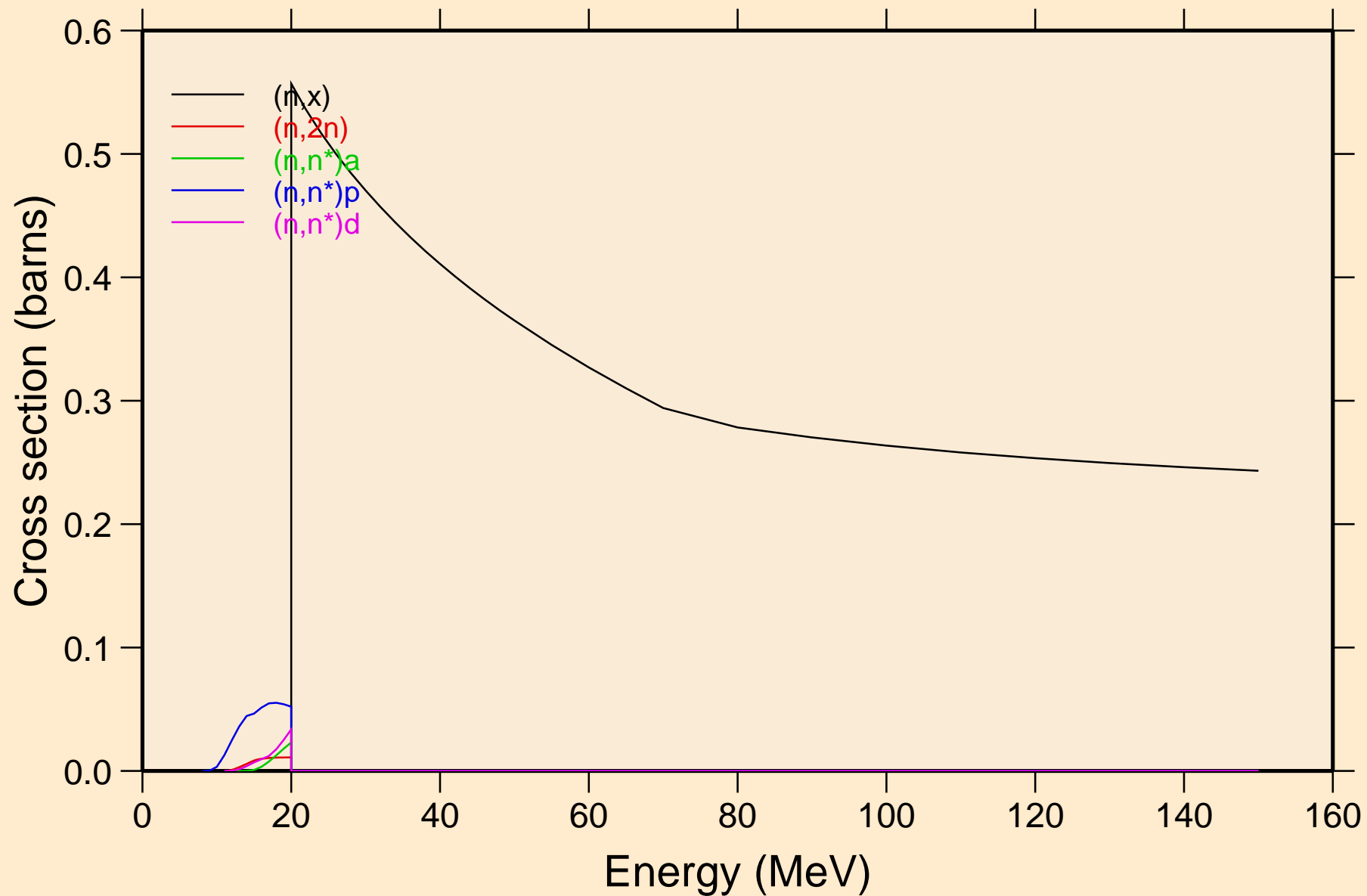

7-N-14 FOR FENDL-3.2 FROM FENDL-3.2 BY NJOY2016.60+ ON D Threshold reactions

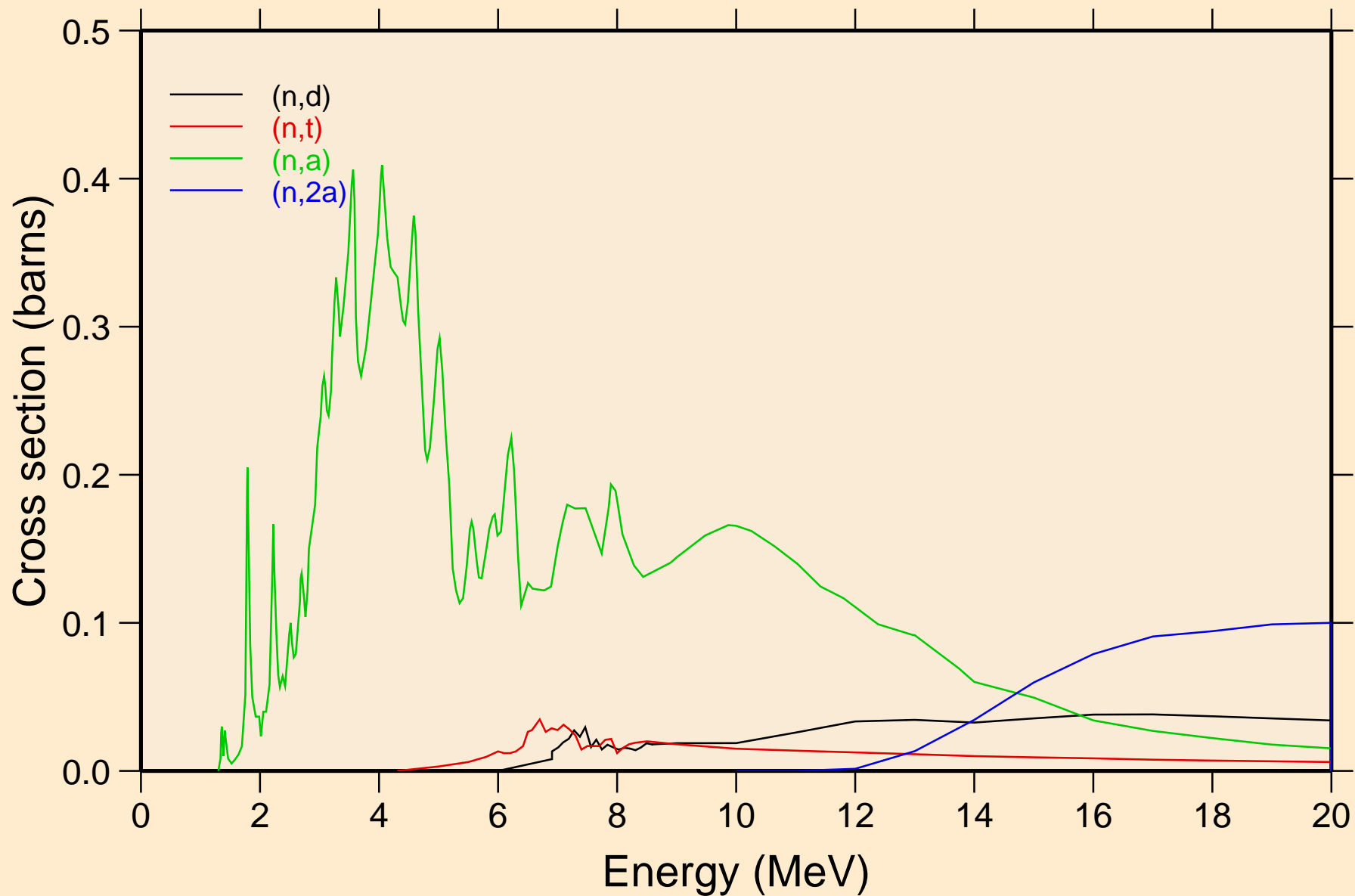

7-N-14 FOR FENDL-3.2 FROM FENDL-3.2 BY NJOY2016.60+ ON D Threshold reactions

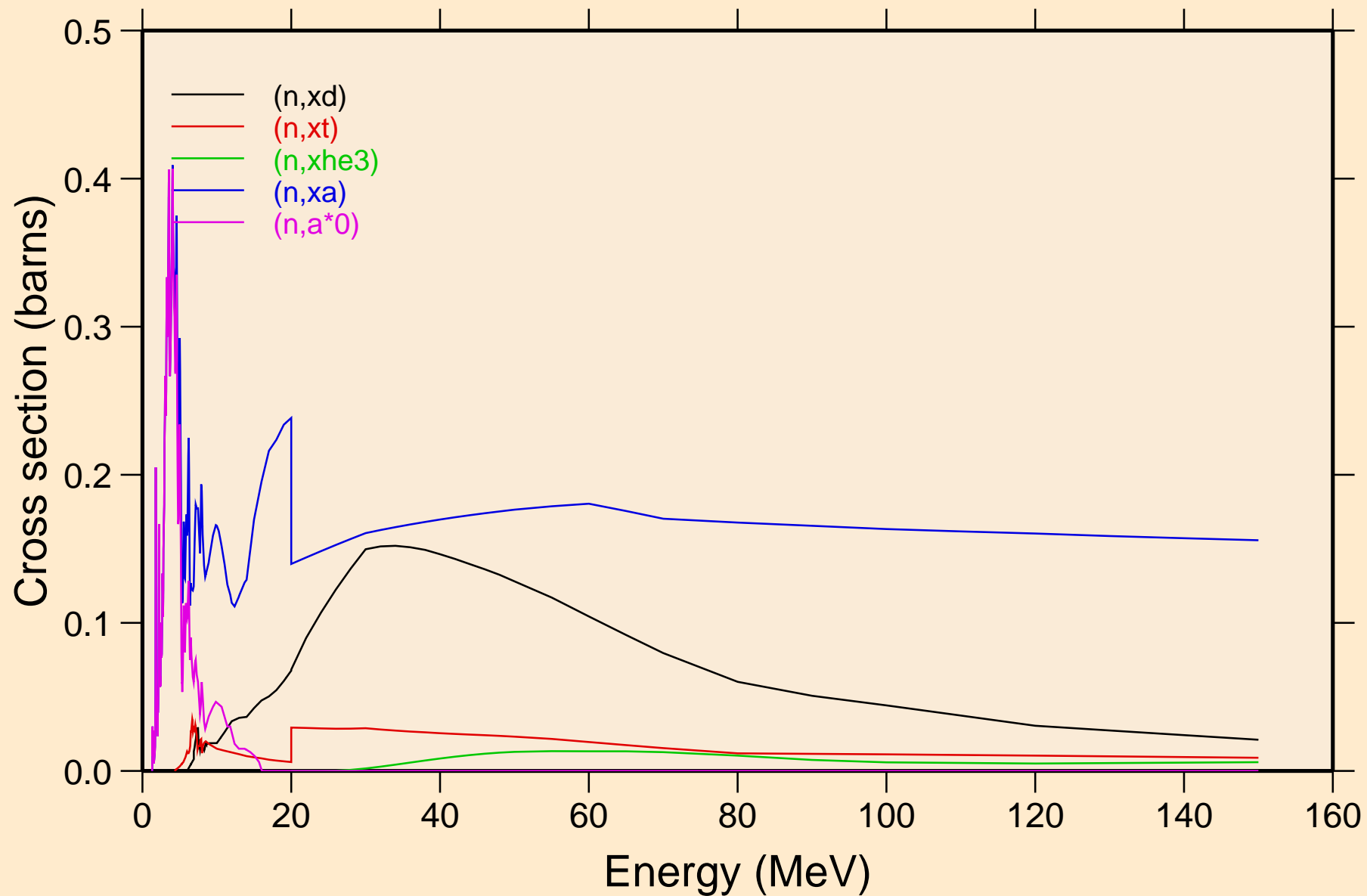

7-N-14 FOR FENDL-3.2 FROM FENDL-3.2 BY NJOY2016.60+ ON D Threshold reactions

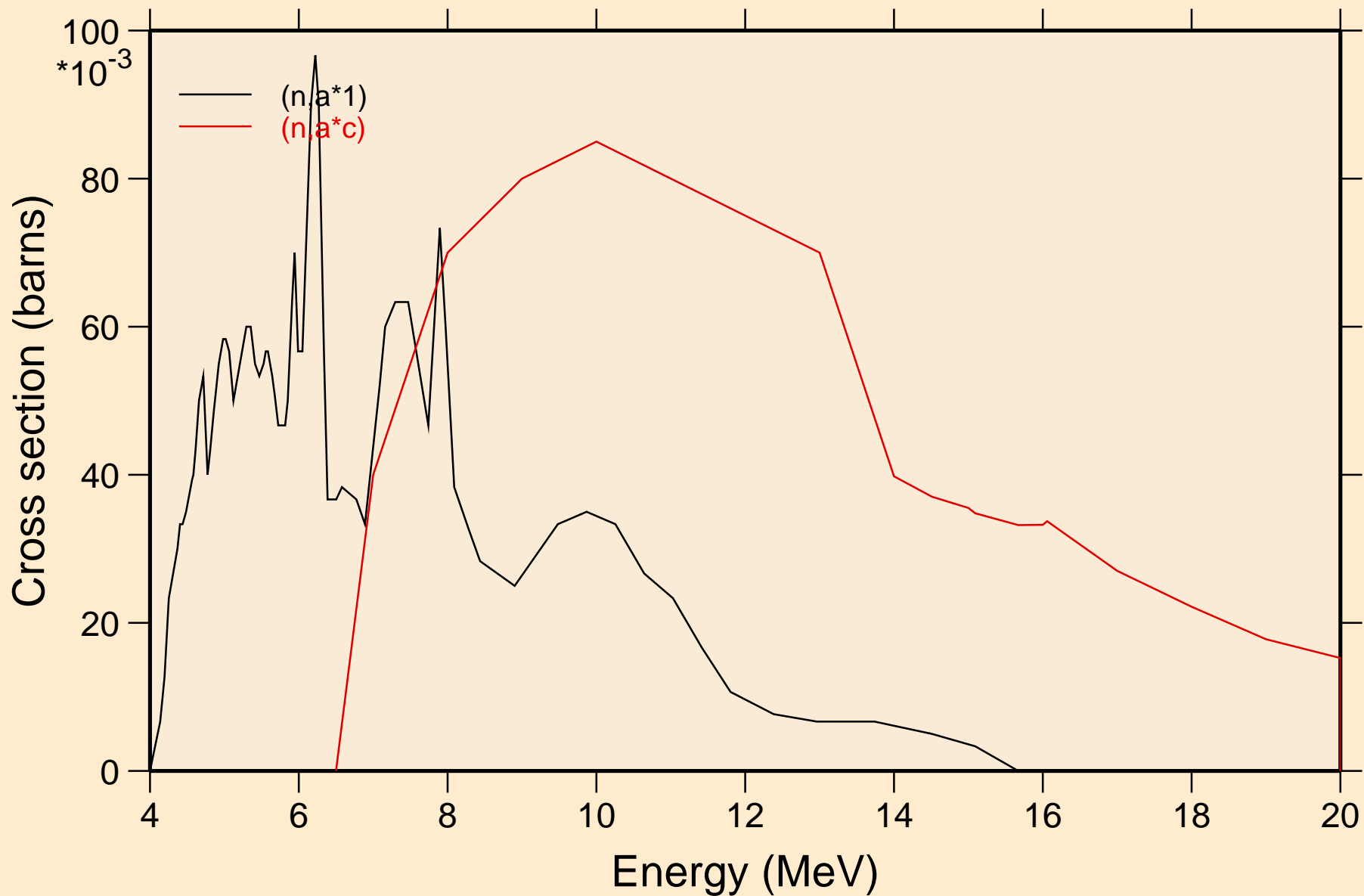

7-N-14 FOR FENDL-3.2 FROM FENDL-3.2 BY NJOY2016.60+ ON D
angular distribution for elastic

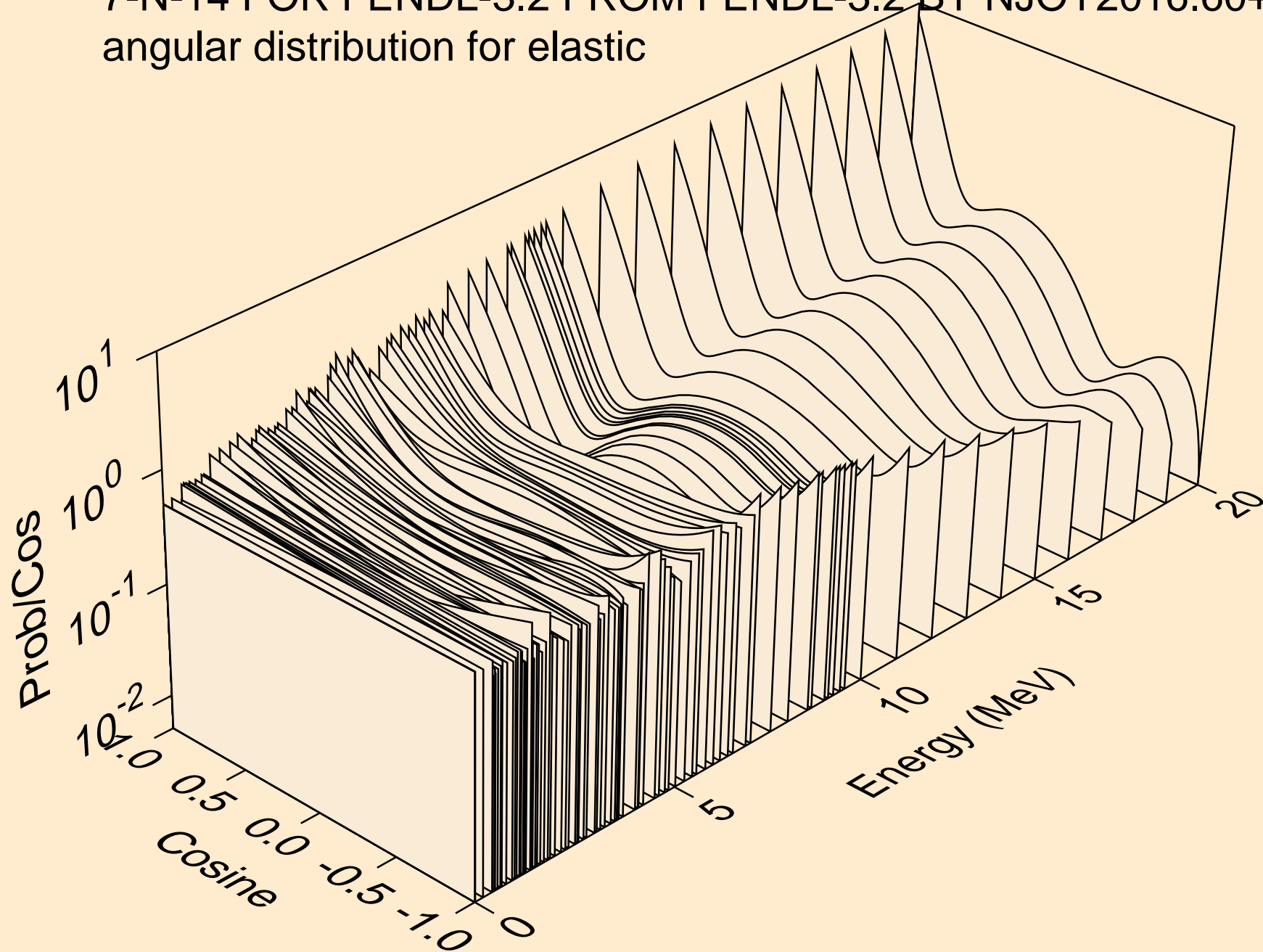

7-N-14 FOR FENDL-3.2 FROM FENDL-3.2 BY NJOY2016.60+ ON D
angular distribution for elastic

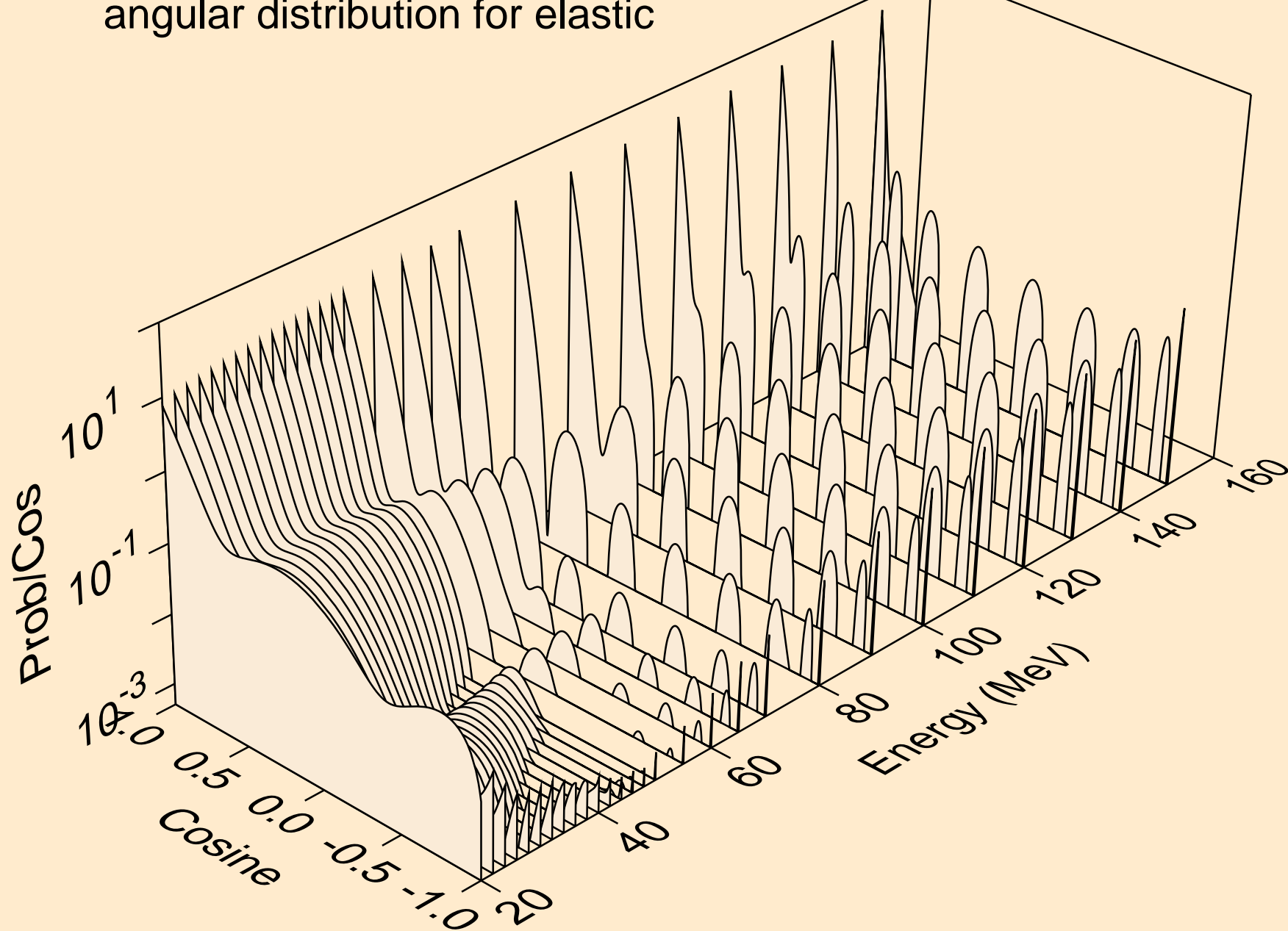

7-N-14 FOR FENDL-3.2 FROM FENDL-3.2 BY NJOY2016.60+ ON D
angular distribution for (n,2n)

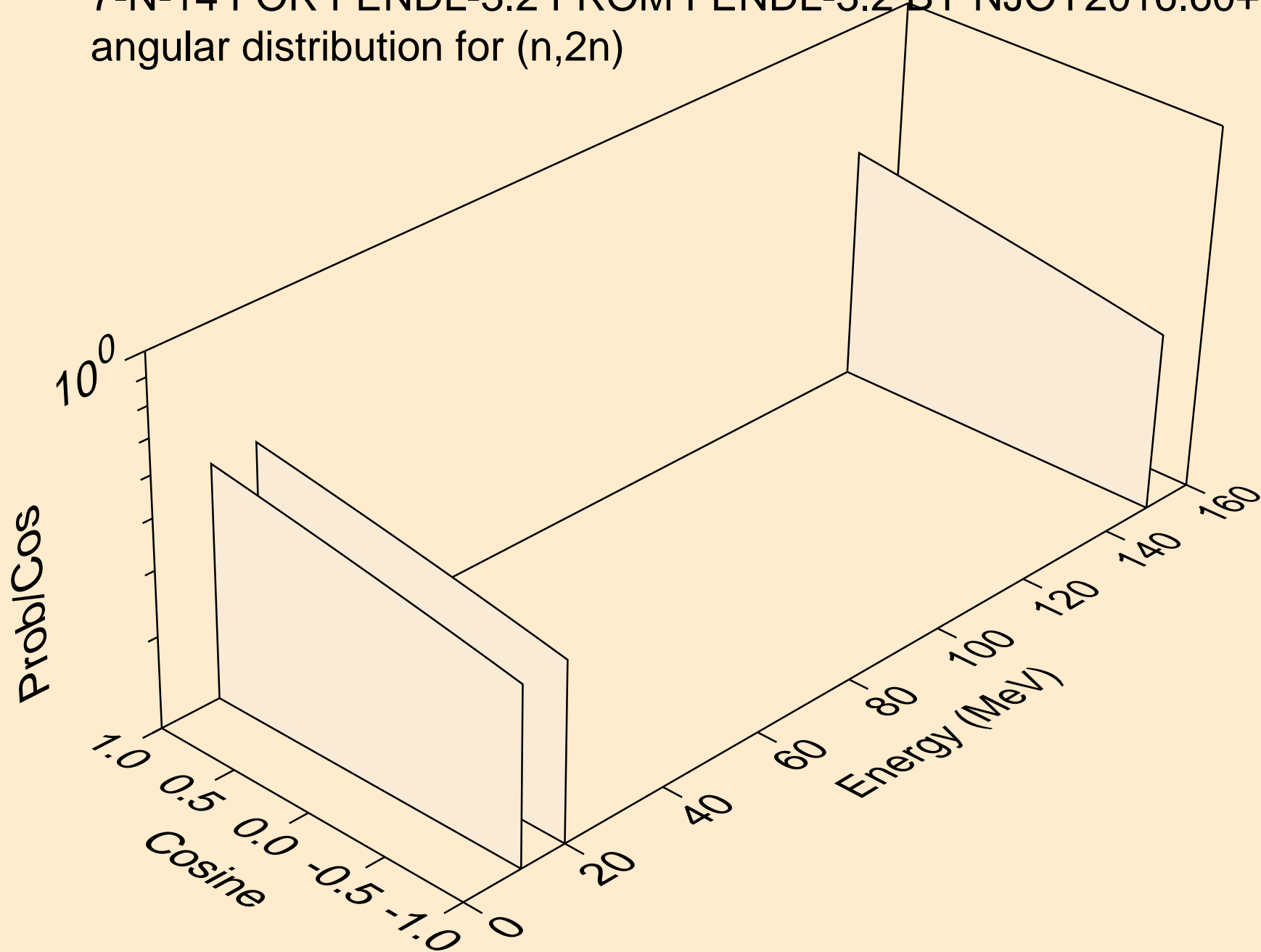

7-N-14 FOR FENDL-3.2 FROM FENDL-3.2 BY NJOY2016.60+ ON D
angular distribution for (n,n*)a

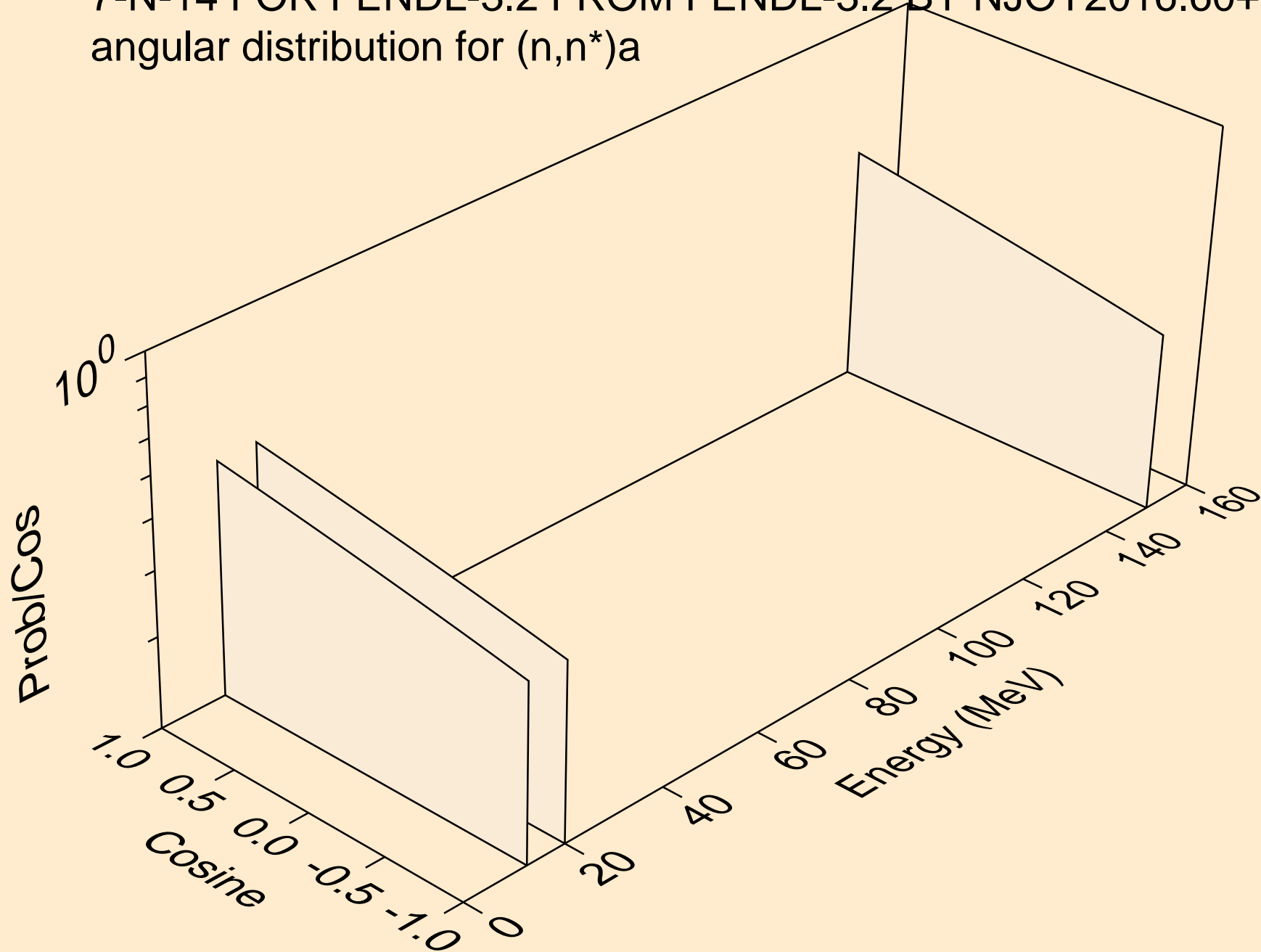

7-N-14 FOR FENDL-3.2 FROM FENDL-3.2 BY NJOY2016.60+ ON D
angular distribution for (n,n*)p

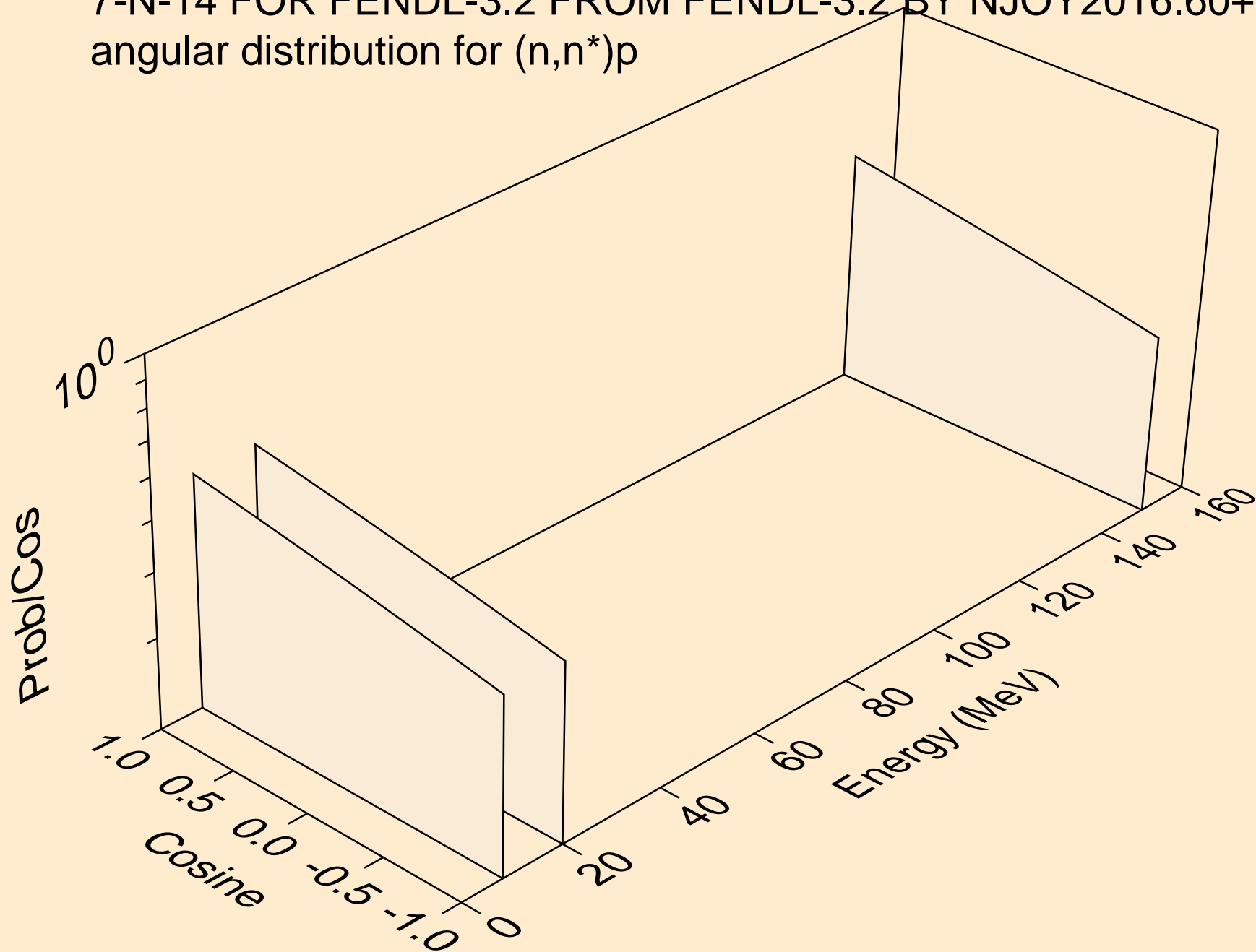

7-N-14 FOR FENDL-3.2 FROM FENDL-3.2 BY NJOY2016.60+ ON D
angular distribution for (n,n*)d

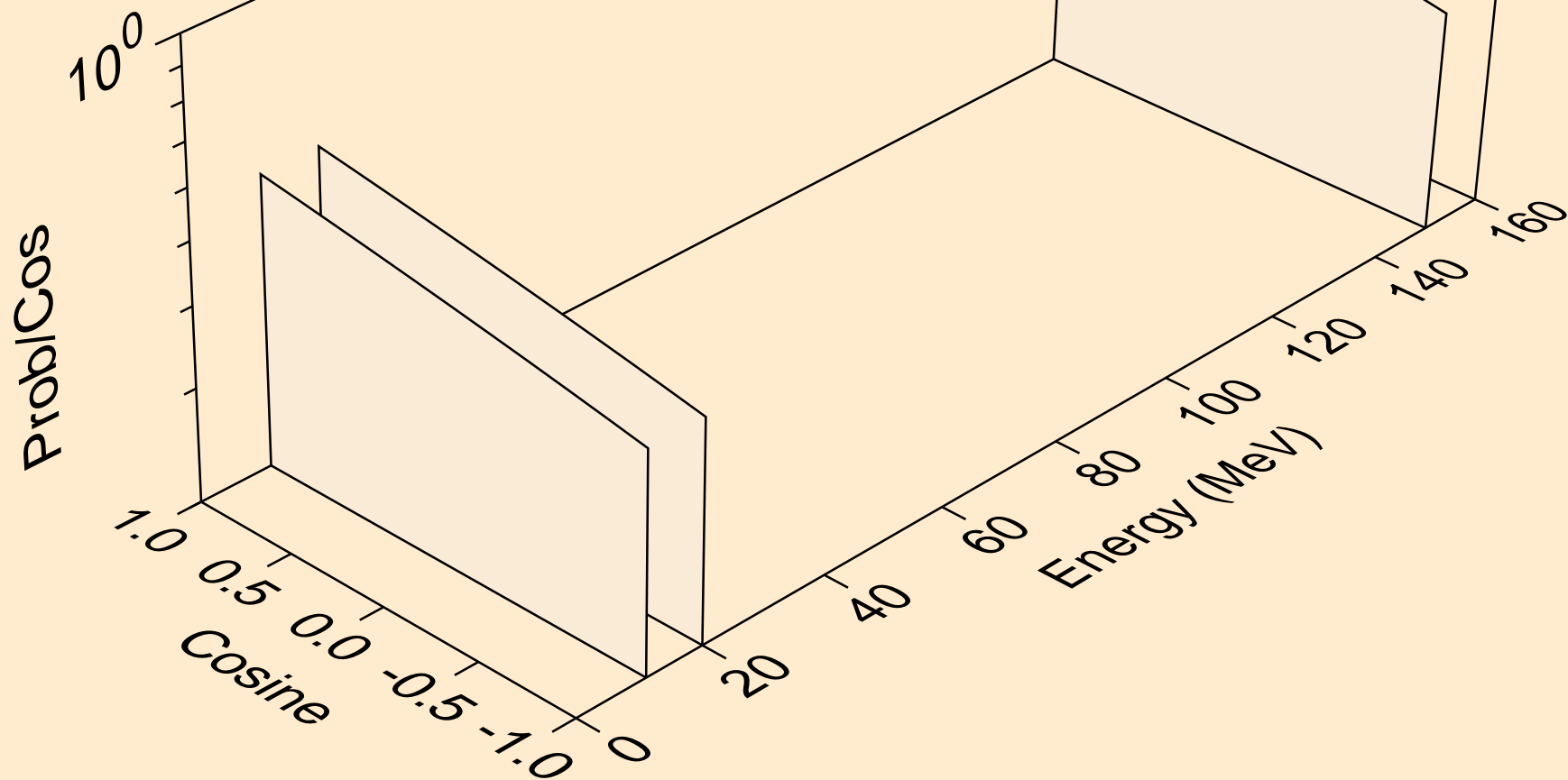

7-N-14 FOR FENDL-3.2 FROM FENDL-3.2 BY NJOY2016.60+ ON D
angular distribution for (n,n*1)

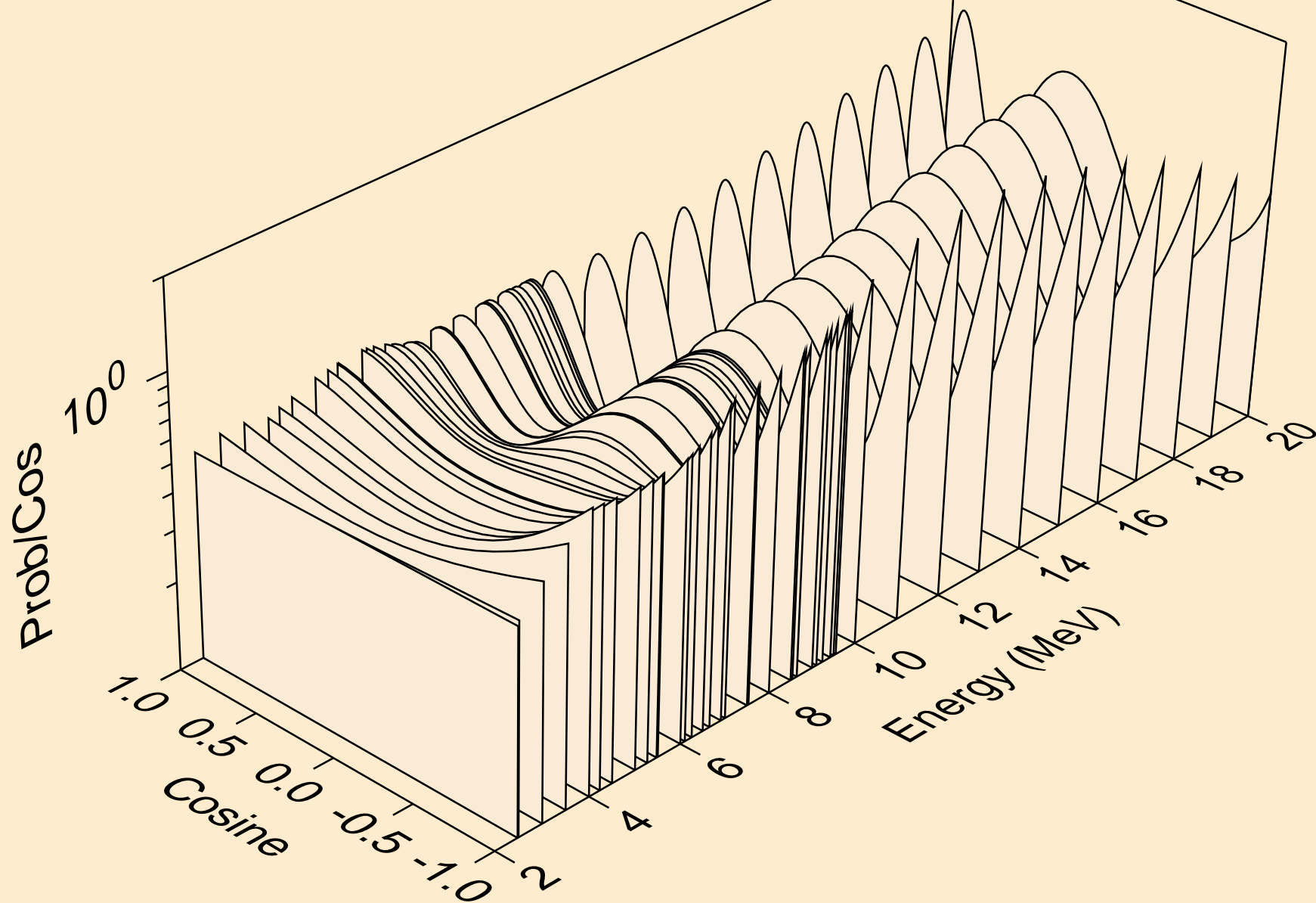

7-N-14 FOR FENDL-3.2 FROM FENDL-3.2 BY NJOY2016.60+ ON D
angular distribution for (n,n*2)

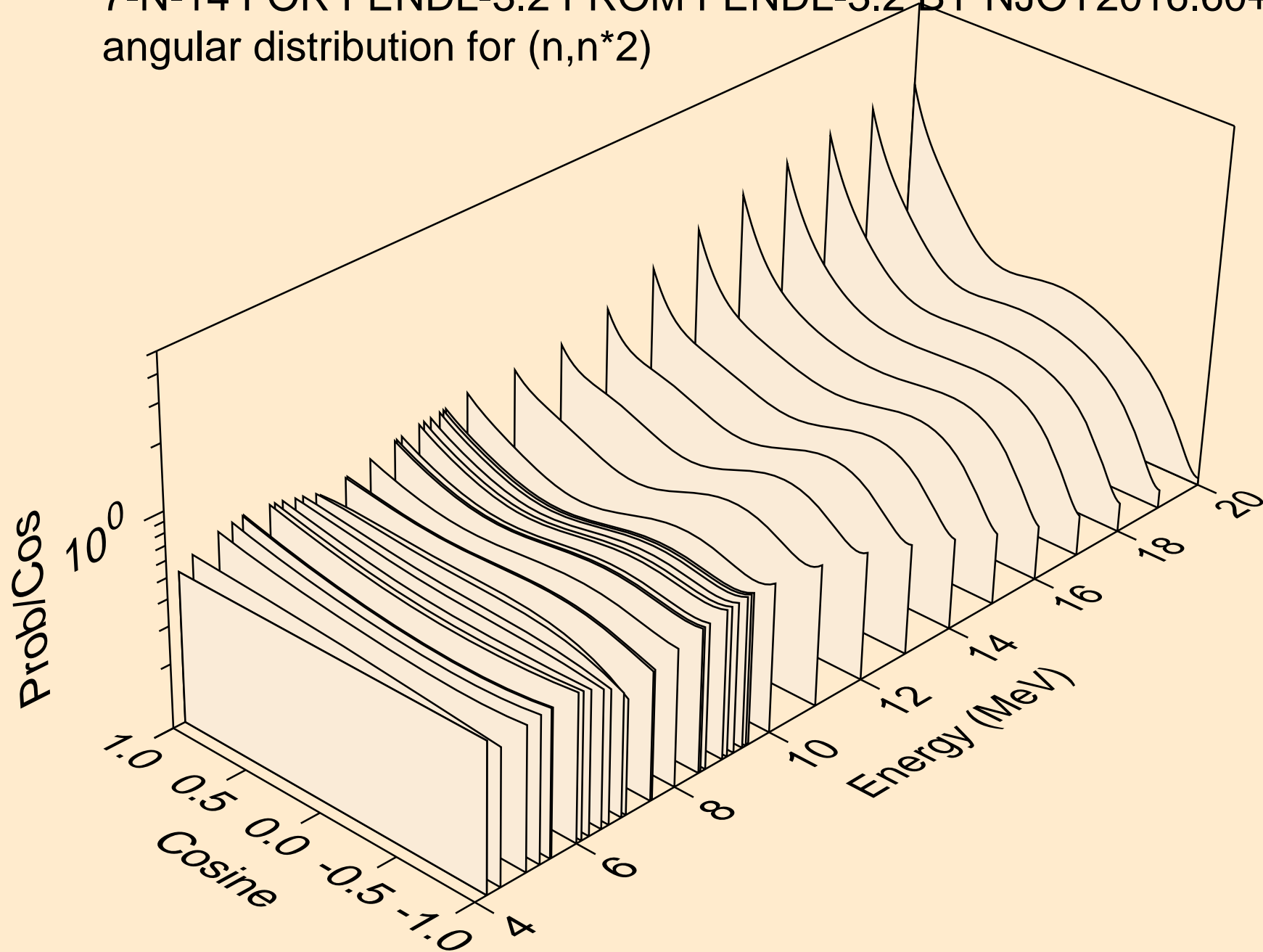

7-N-14 FOR FENDL-3.2 FROM FENDL-3.2 BY NJOY2016.60+ ON D
angular distribution for (n,n*3)

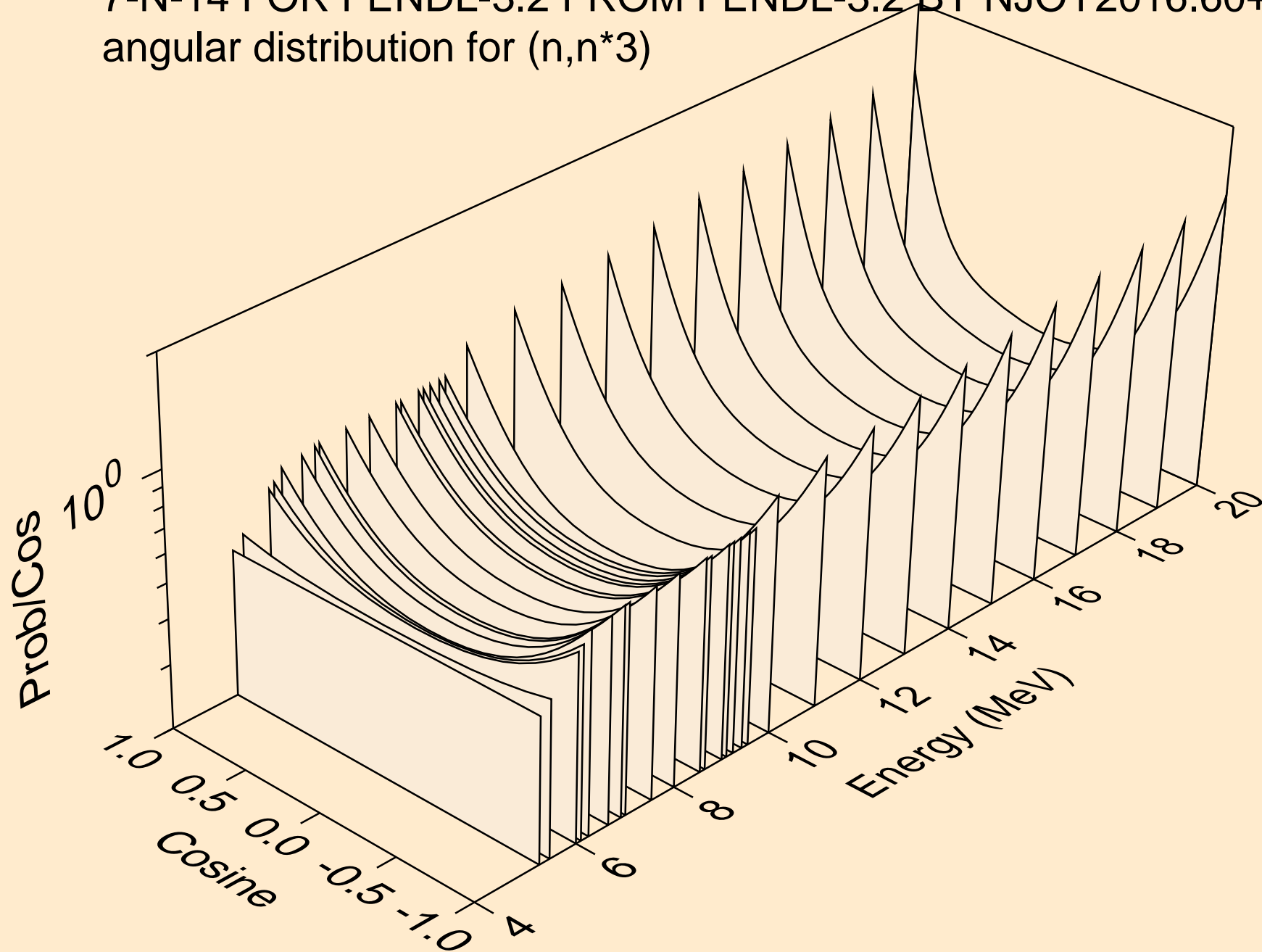

7-N-14 FOR FENDL-3.2 FROM FENDL-3.2 BY NJOY2016.60+ ON D
angular distribution for (n,n*4)

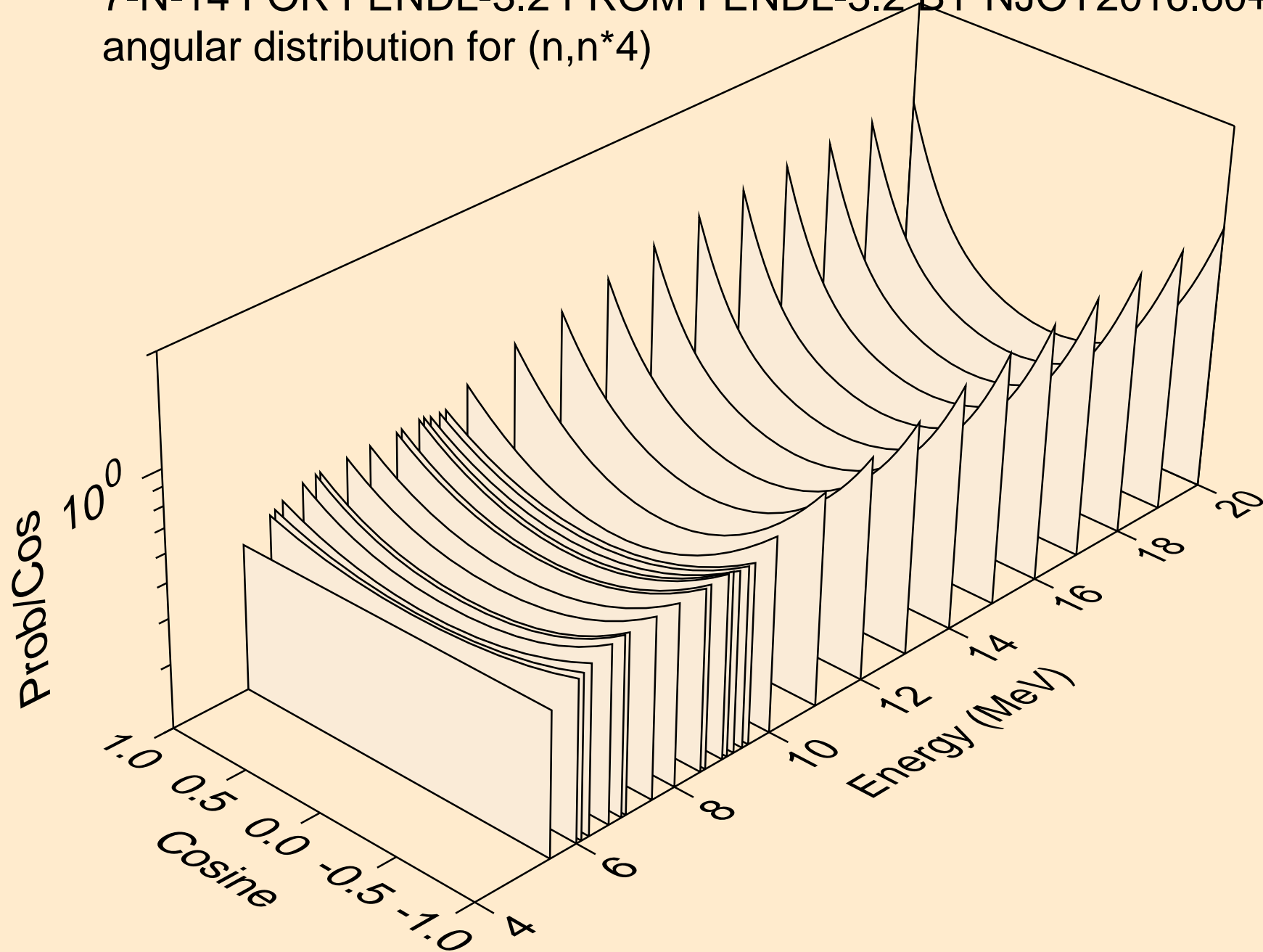

7-N-14 FOR FENDL-3.2 FROM FENDL-3.2 BY NJOY2016.60+ ON D
angular distribution for (n,n*5)

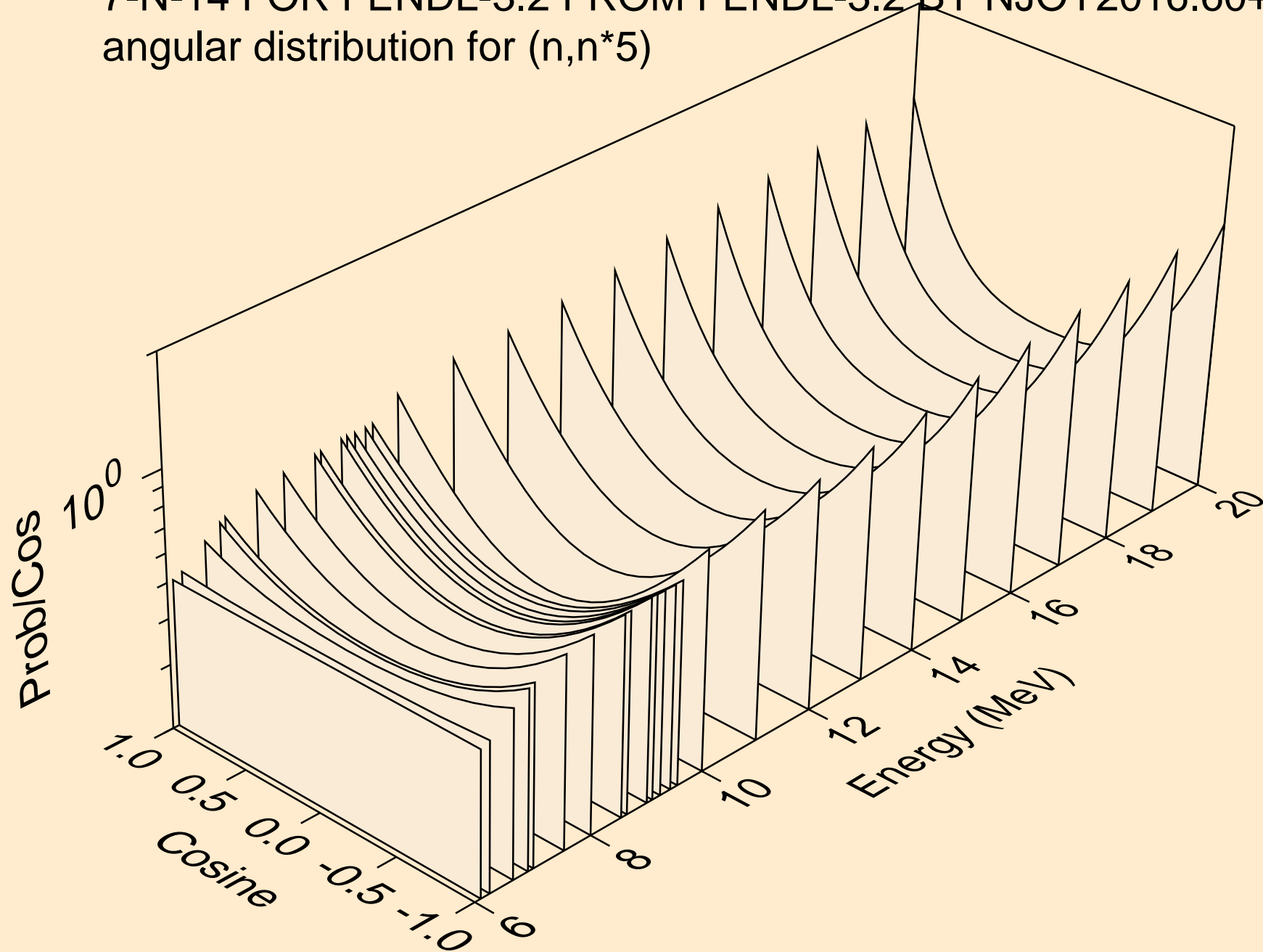

7-N-14 FOR FENDL-3.2 FROM FENDL-3.2 BY NJOY2016.60+ ON D
angular distribution for (n,n*6)

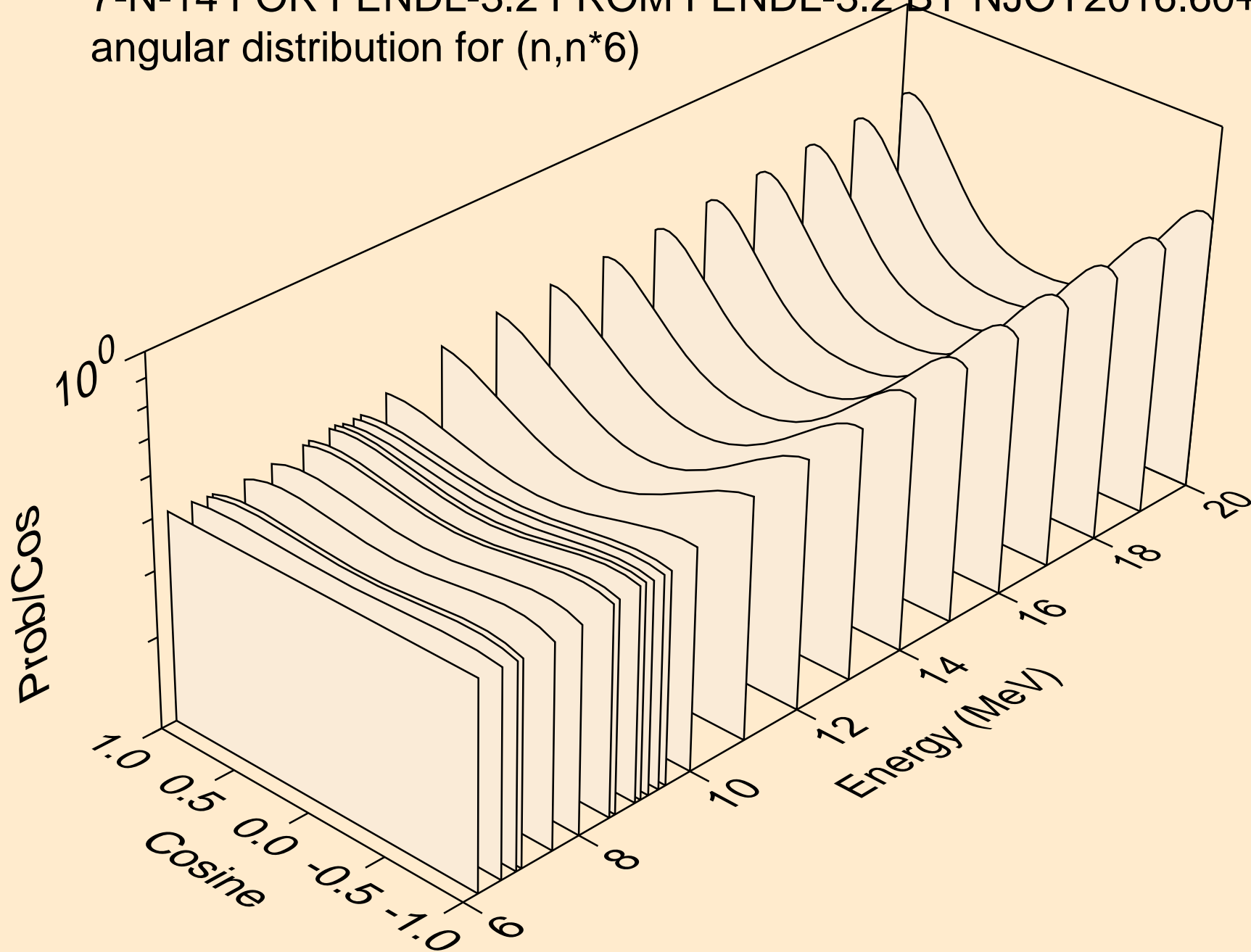

7-N-14 FOR FENDL-3.2 FROM FENDL-3.2 BY NJOY2016.60+ ON D
angular distribution for (n,n*7)

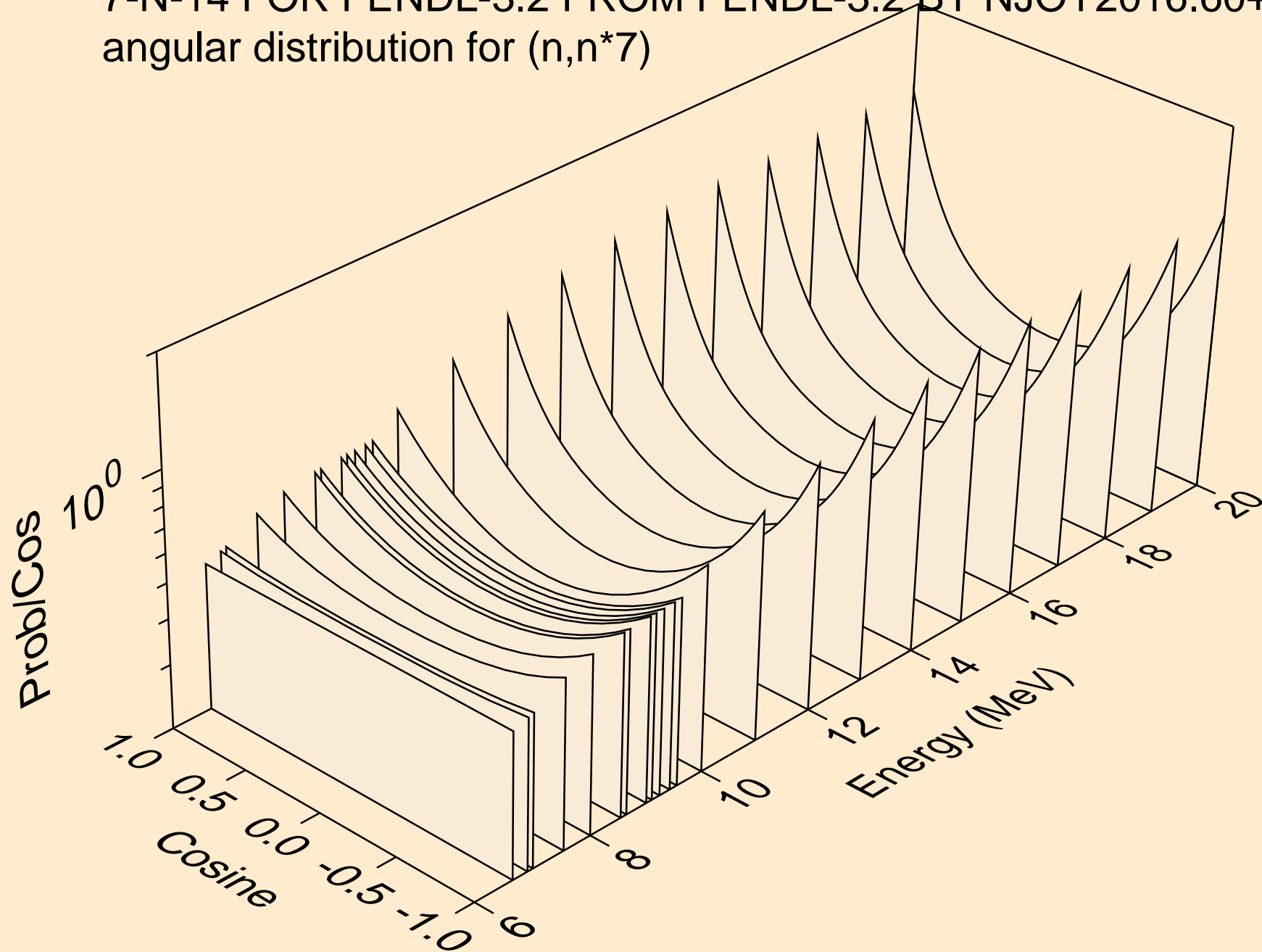

7-N-14 FOR FENDL-3.2 FROM FENDL-3.2 BY NJOY2016.60+ ON D
angular distribution for (n,n*8)

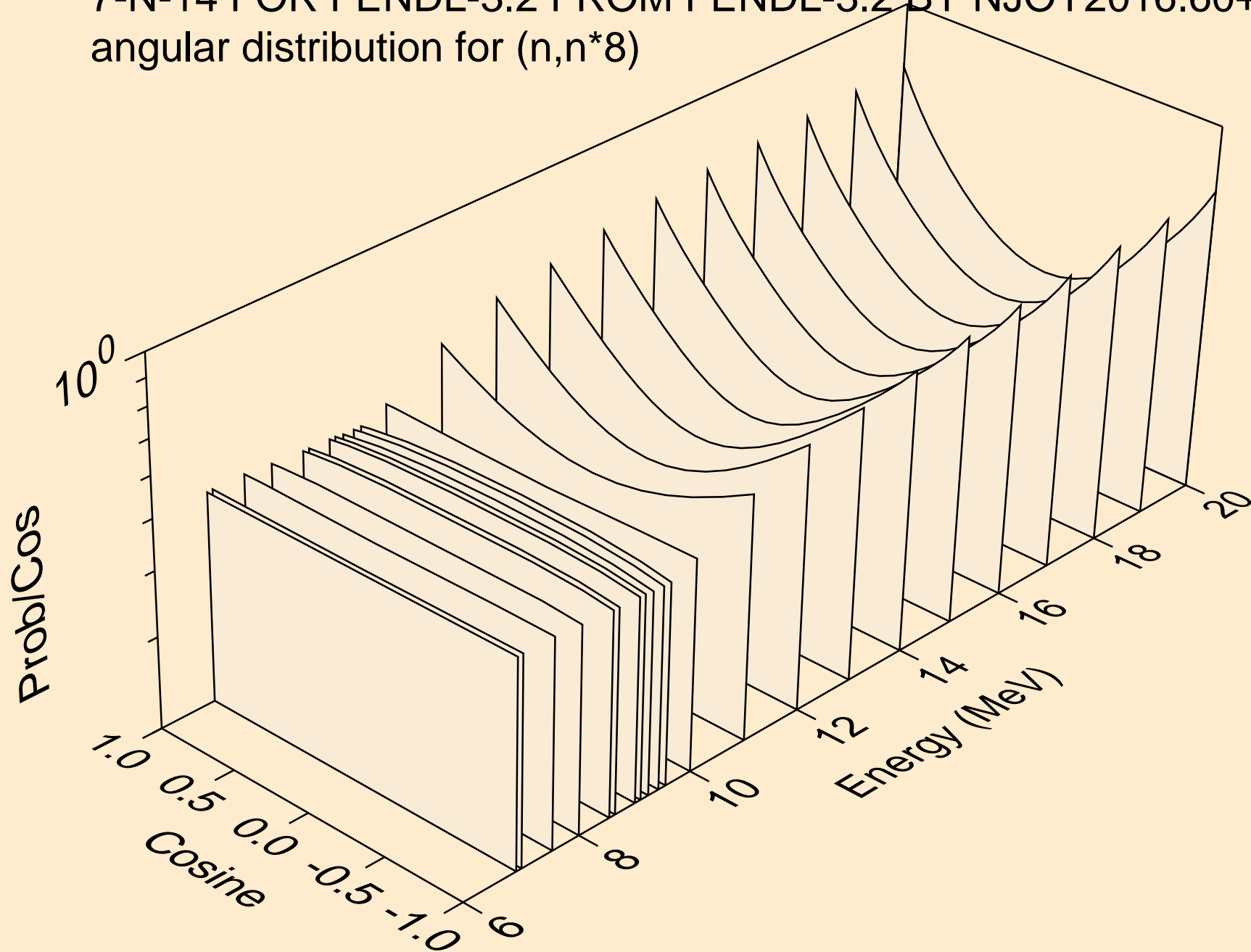

7-N-14 FOR FENDL-3.2 FROM FENDL-3.2 BY NJOY2016.60+ ON D
angular distribution for (n,n*9)

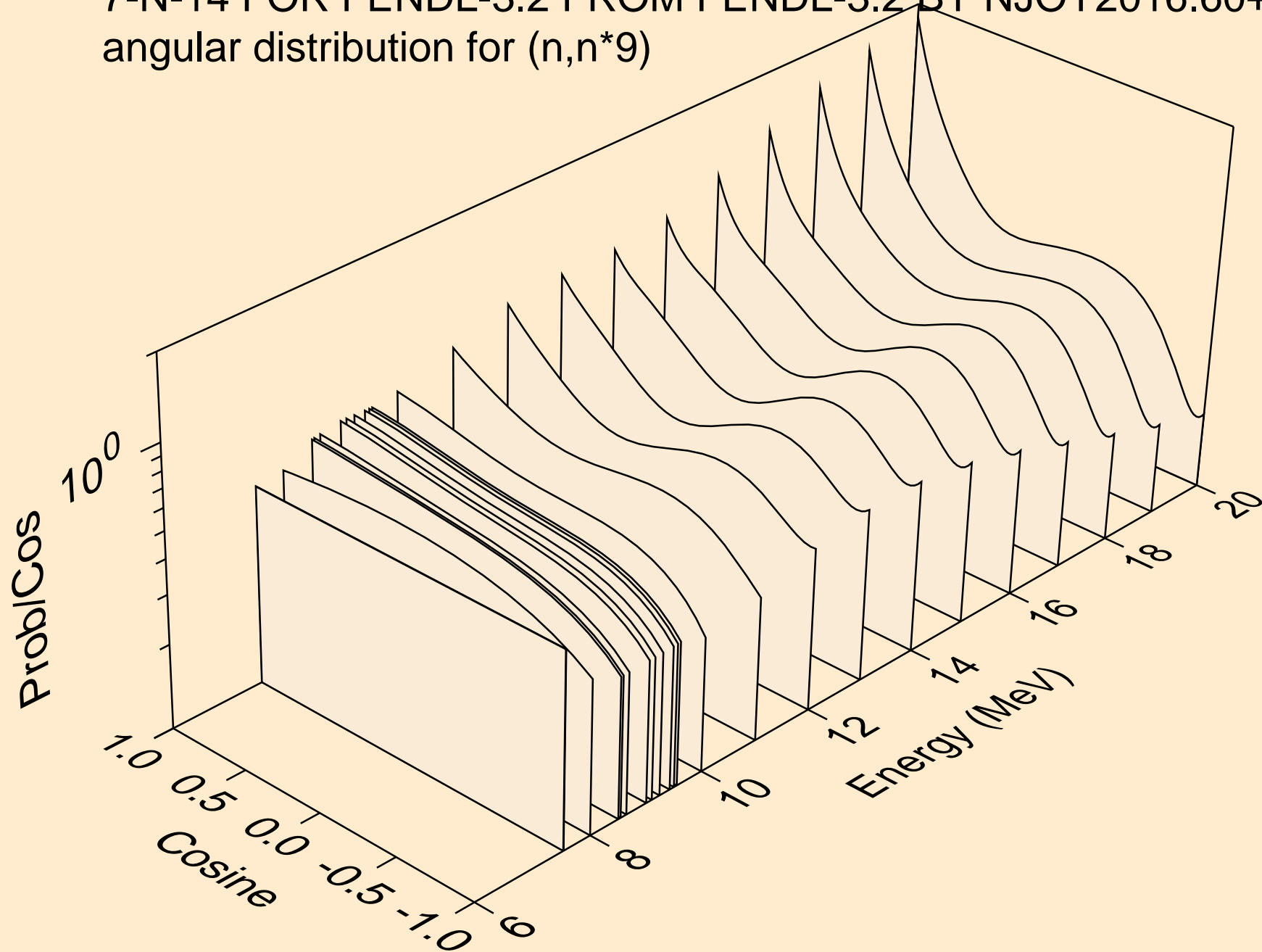

7-N-14 FOR FENDL-3.2 FROM FENDL-3.2 BY NJOY2016.60+ ON D
angular distribution for (n,n*10)

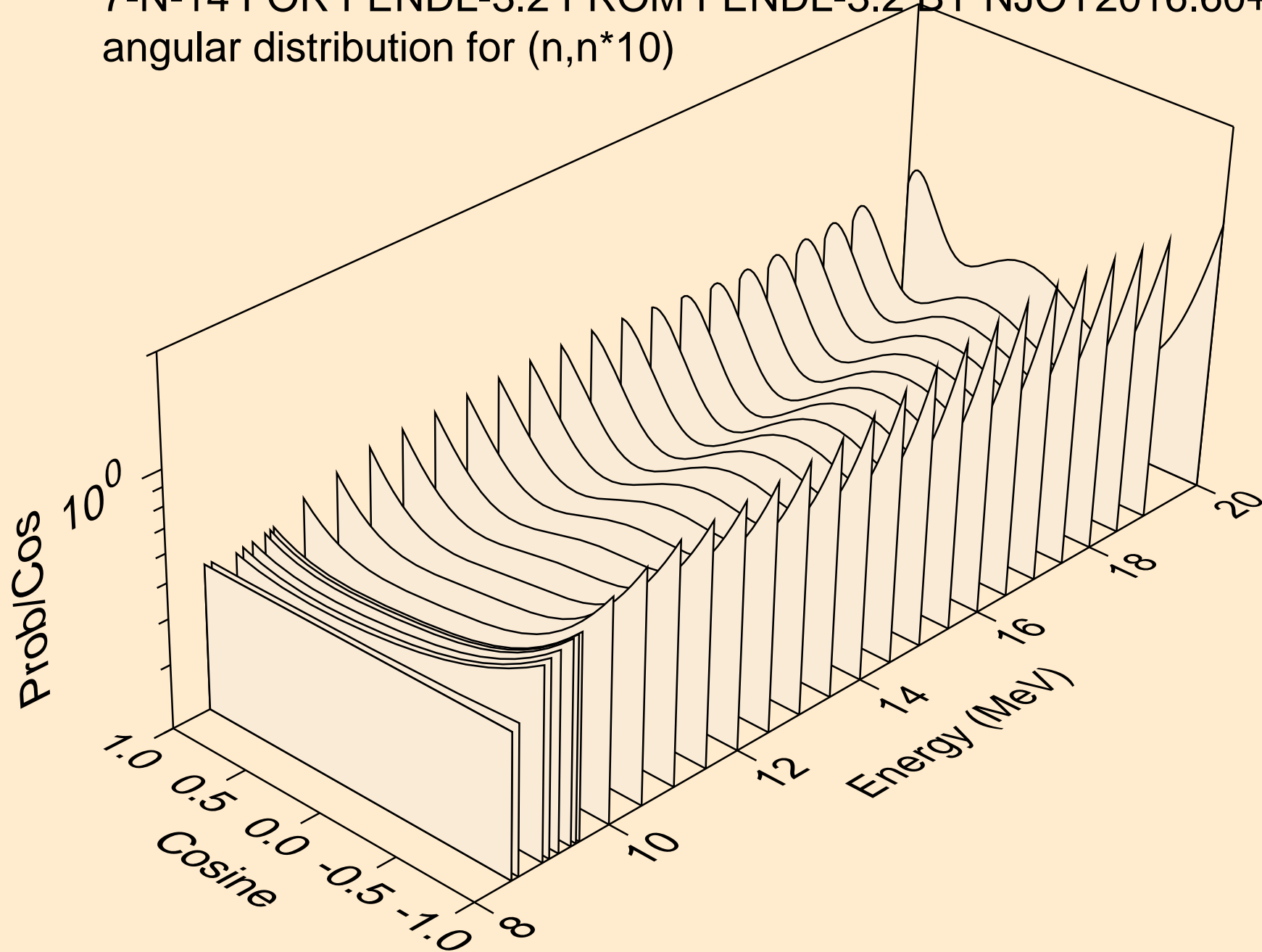

7-N-14 FOR FENDL-3.2 FROM FENDL-3.2 BY NJOY2016.60+ ON D
angular distribution for (n,n*11)

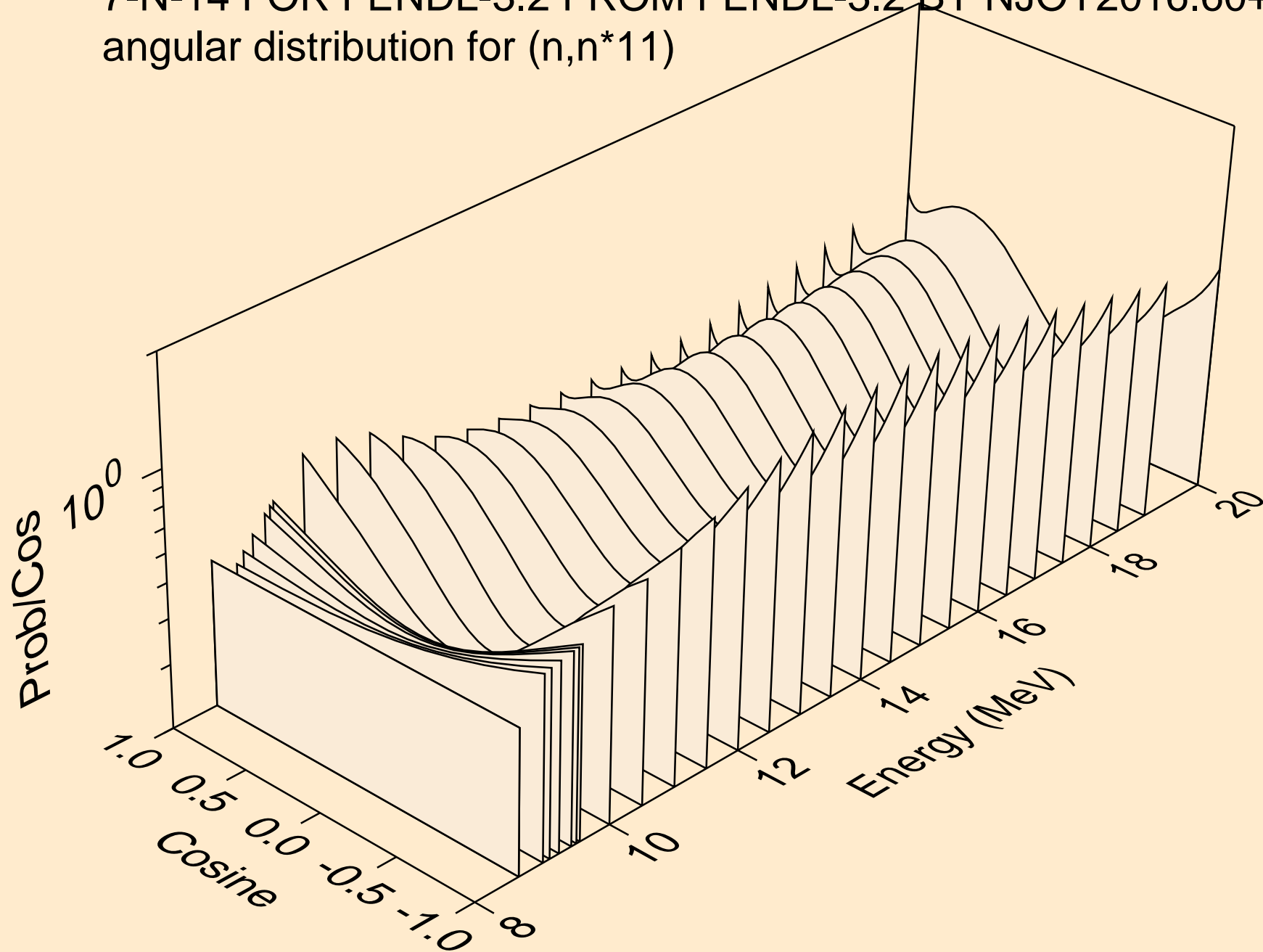

7-N-14 FOR FENDL-3.2 FROM FENDL-3.2 BY NJOY2016.60+ ON D
angular distribution for (n,n*12)

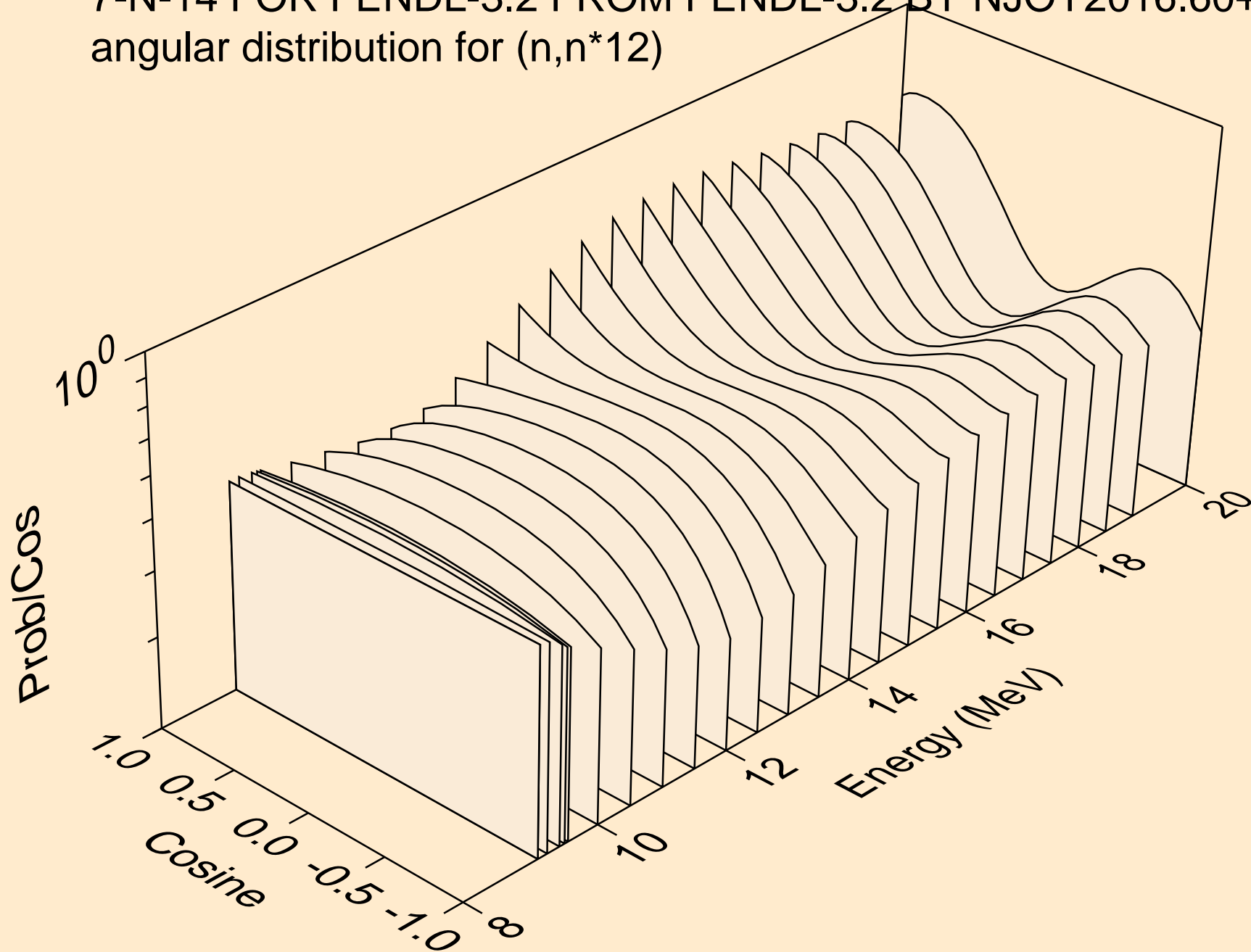

7-N-14 FOR FENDL-3.2 FROM FENDL-3.2 BY NJOY2016.60+ ON D
angular distribution for (n,n*13)

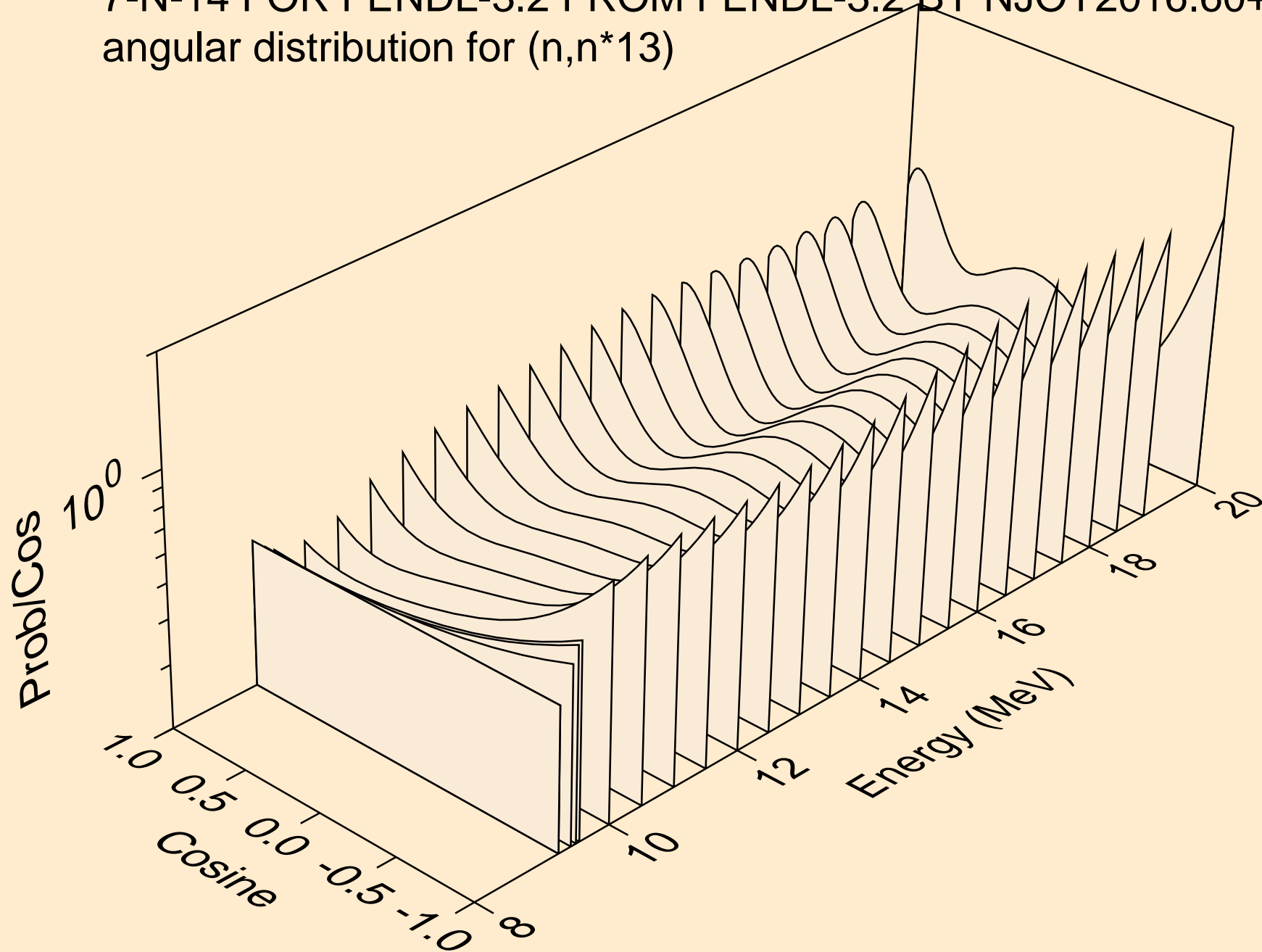

7-N-14 FOR FENDL-3.2 FROM FENDL-3.2 BY NJOY2016.60+ ON D
angular distribution for (n,n*14)

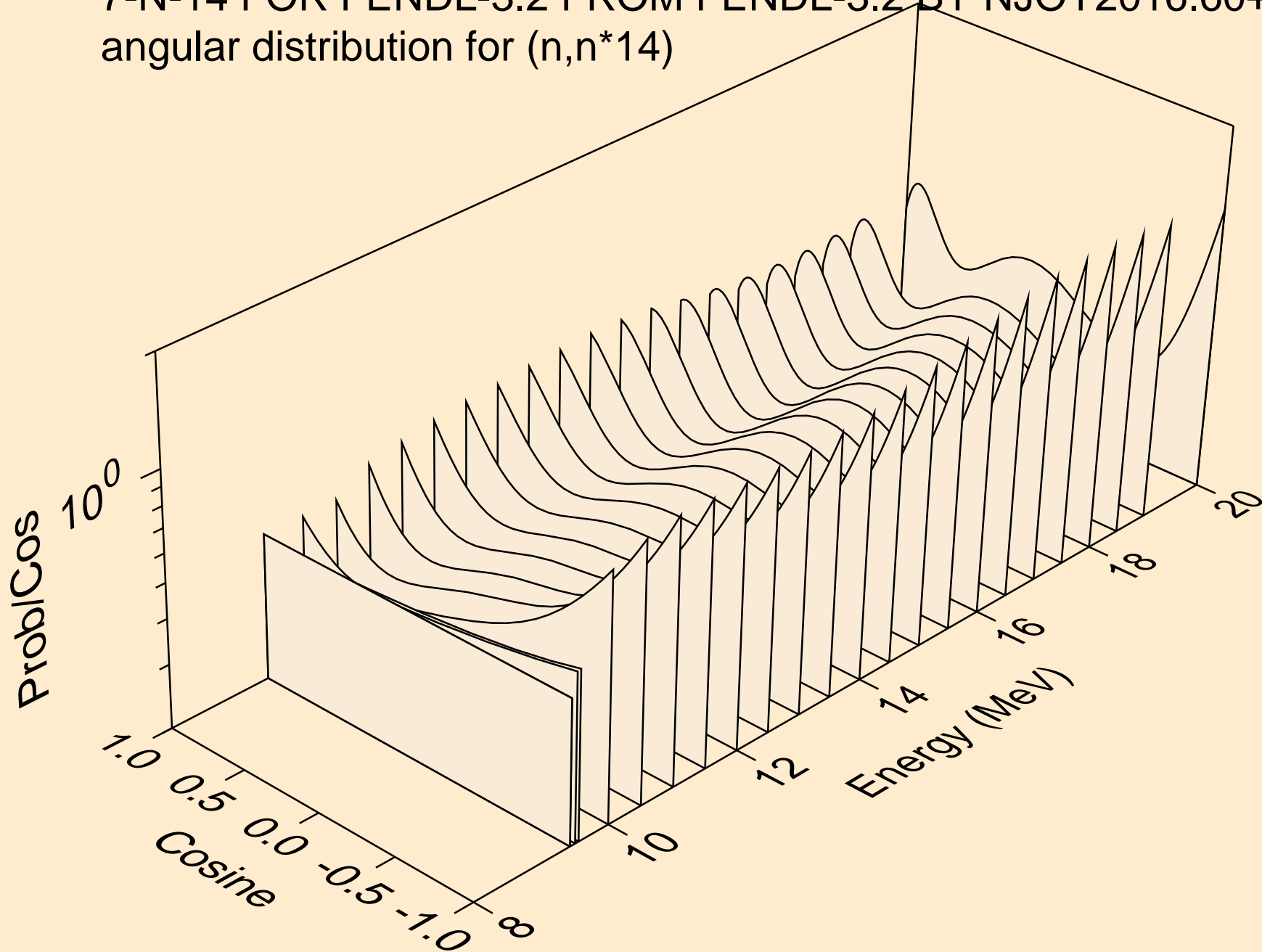

7-N-14 FOR FENDL-3.2 FROM FENDL-3.2 BY NJOY2016.60+ ON D
angular distribution for (n,n*15)

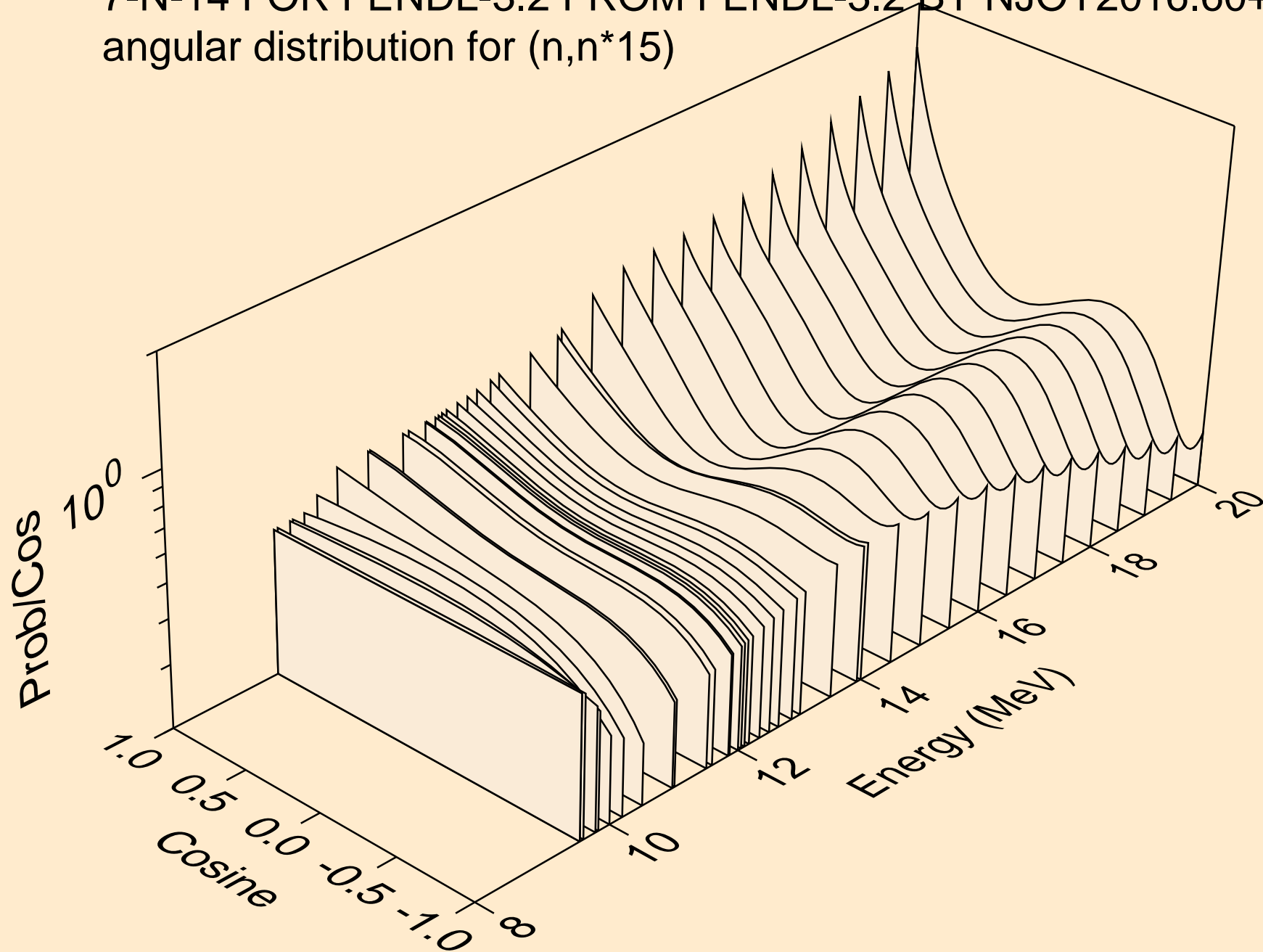

7-N-14 FOR FENDL-3.2 FROM FENDL-3.2 BY NJOY2016.60+ ON D
angular distribution for (n,n*16)

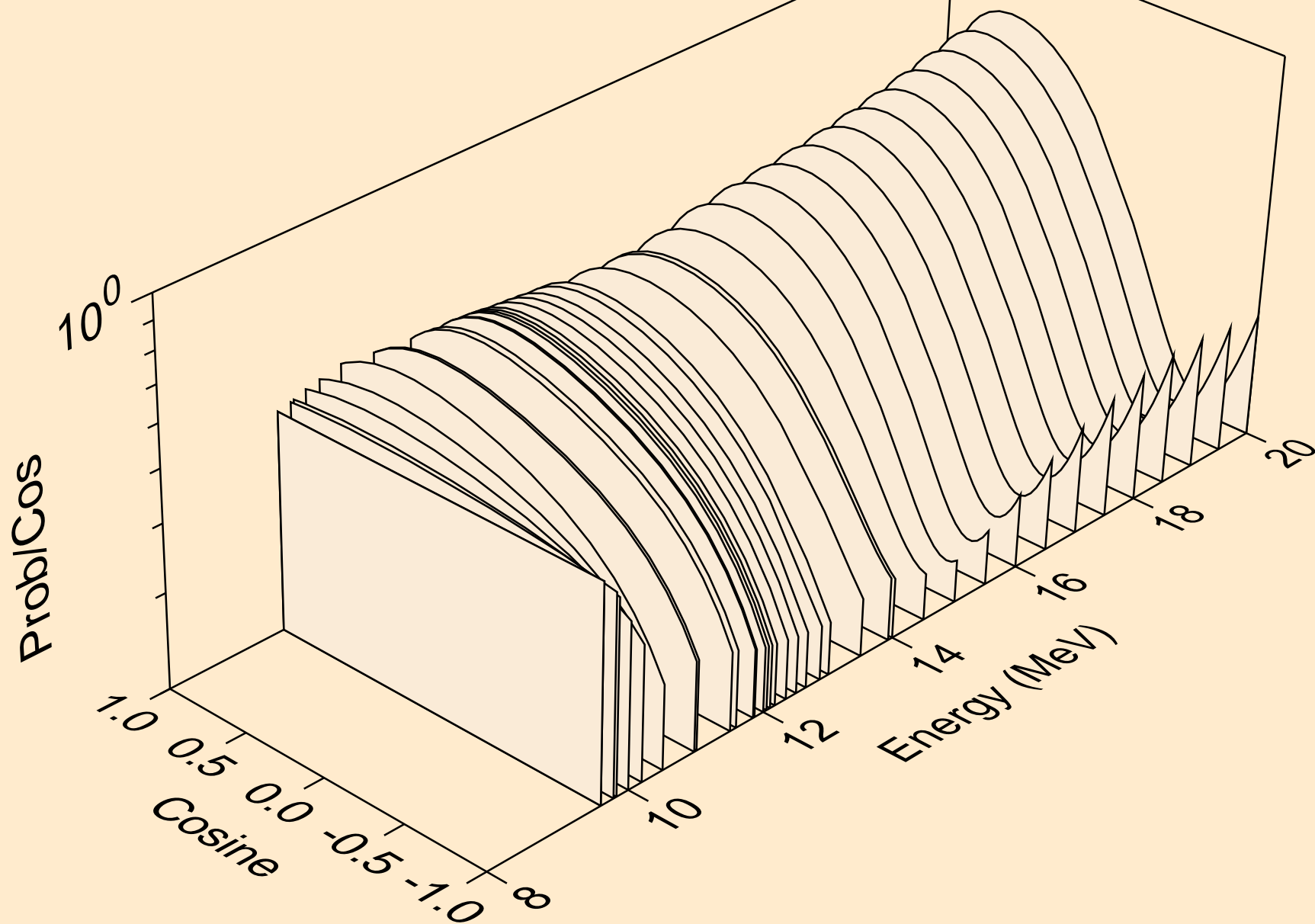

7-N-14 FOR FENDL-3.2 FROM FENDL-3.2 BY NJOY2016.60+ ON D
angular distribution for (n,n*17)

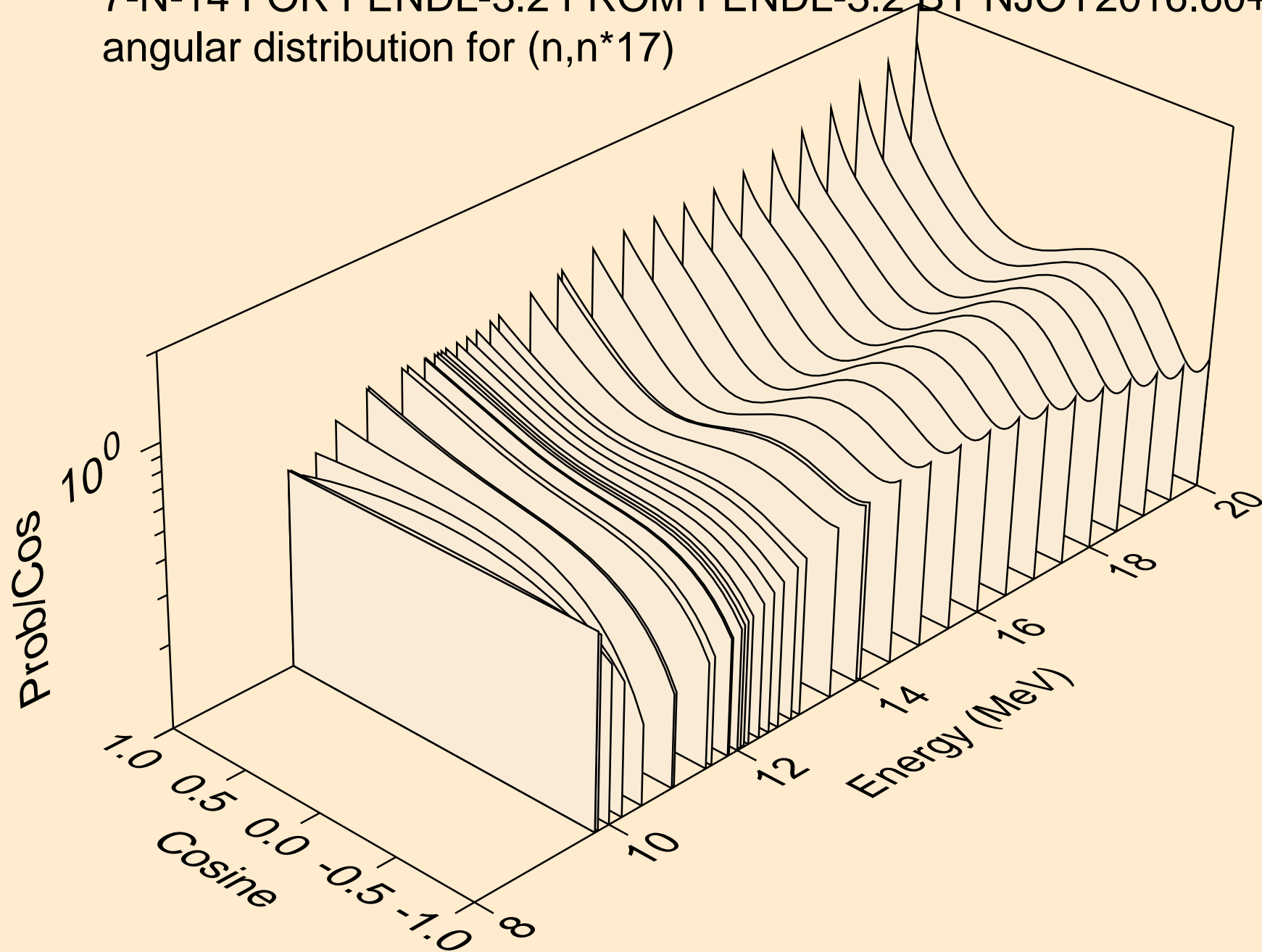

7-N-14 FOR FENDL-3.2 FROM FENDL-3.2 BY NJOY2016.60+ ON D
angular distribution for (n,n*18)

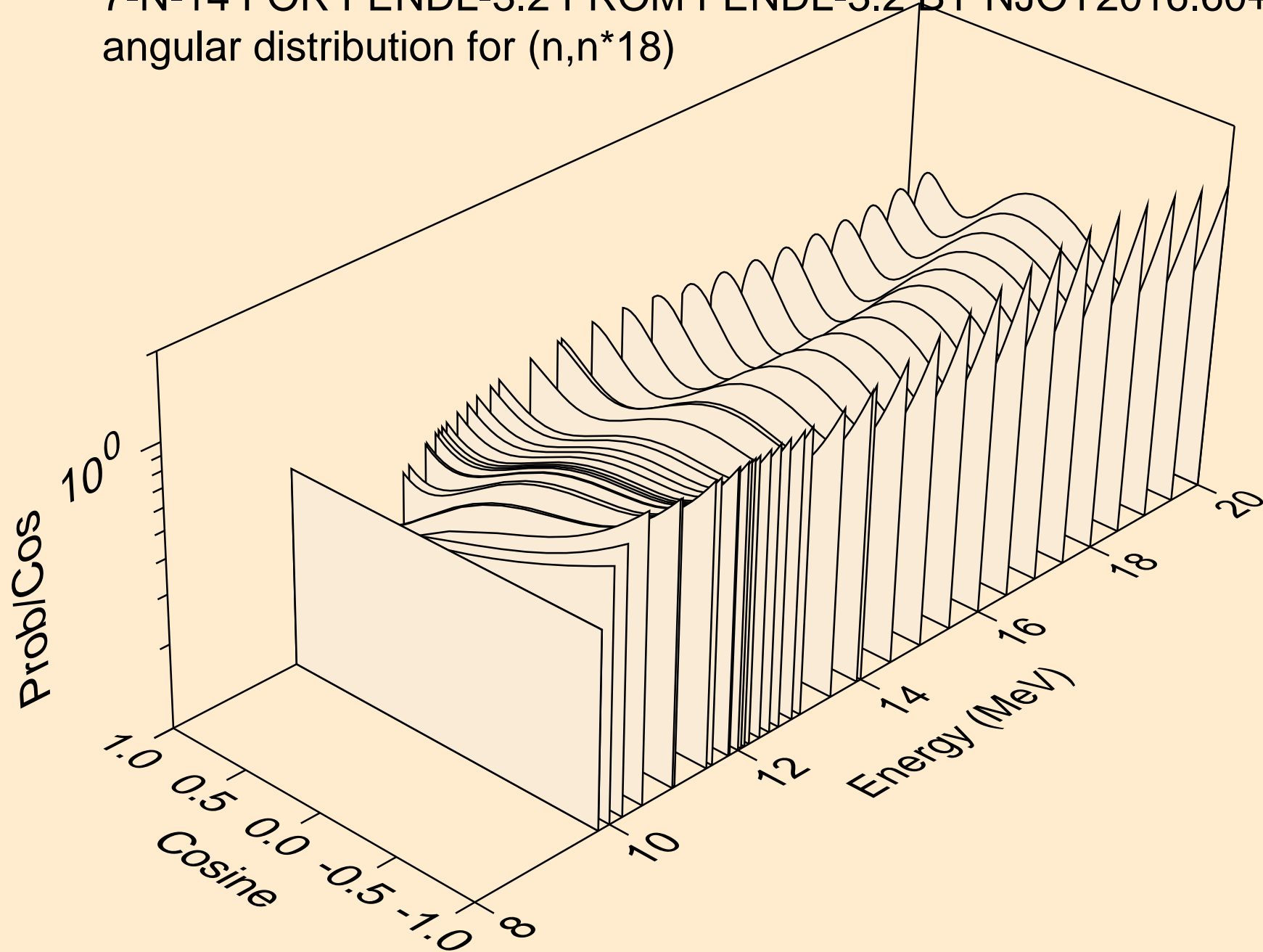

7-N-14 FOR FENDL-3.2 FROM FENDL-3.2 BY NJOY2016.60+ ON D
angular distribution for (n,n*19)

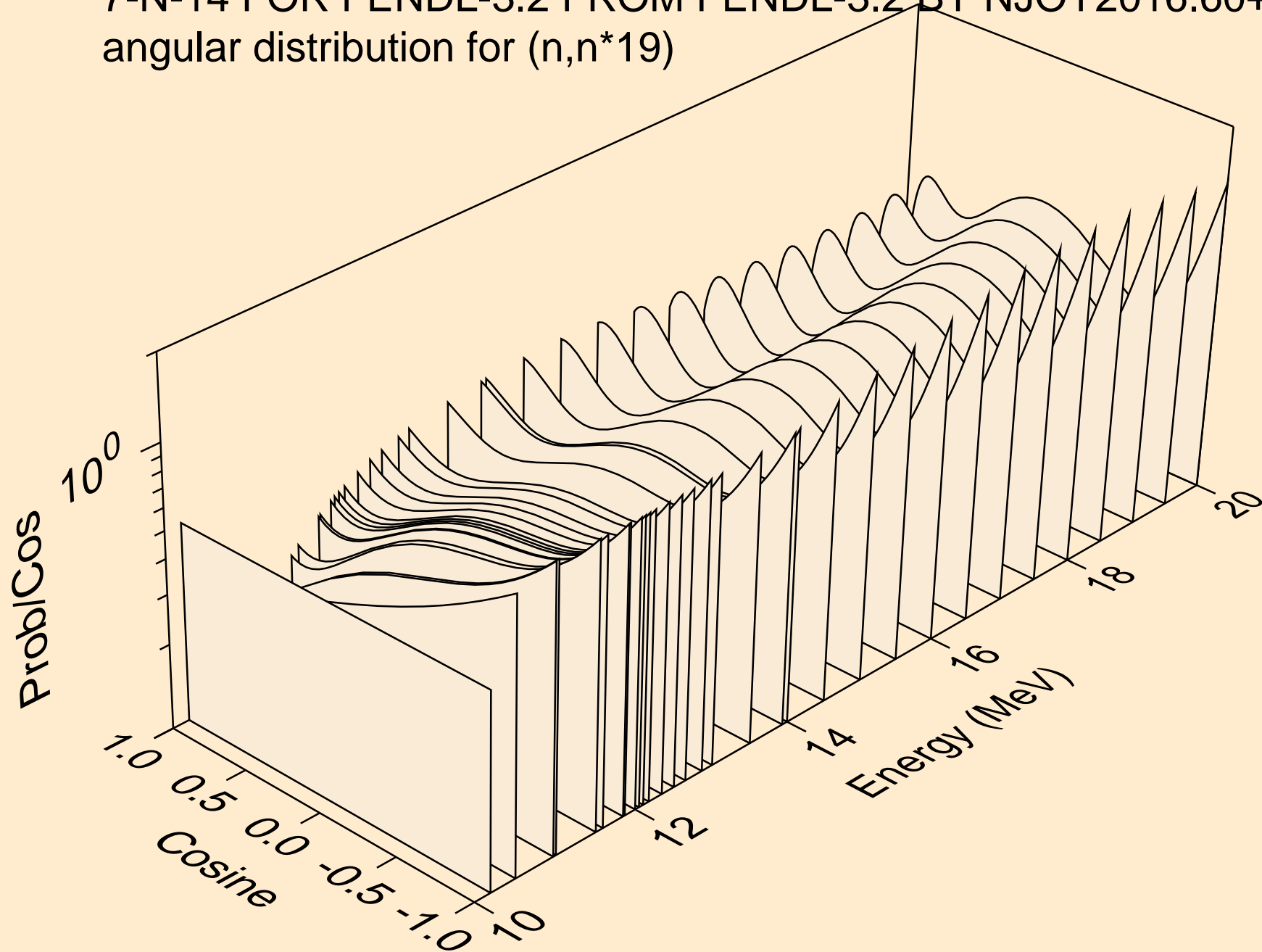

7-N-14 FOR FENDL-3.2 FROM FENDL-3.2 BY NJOY2016.60+ ON D
angular distribution for (n,n*20)

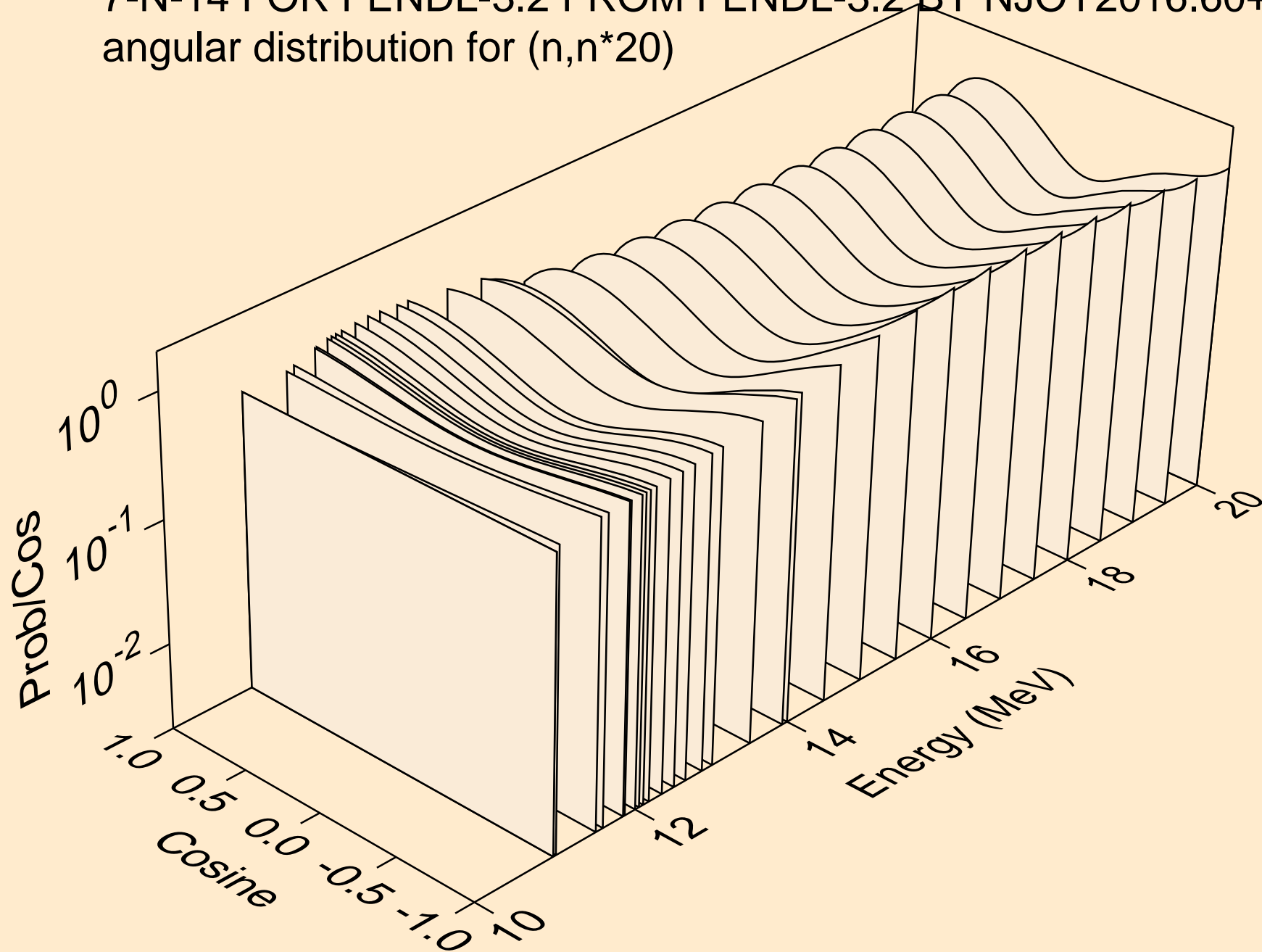

7-N-14 FOR FENDL-3.2 FROM FENDL-3.2 BY NJOY2016.60+ ON D
angular distribution for (n,n*21)

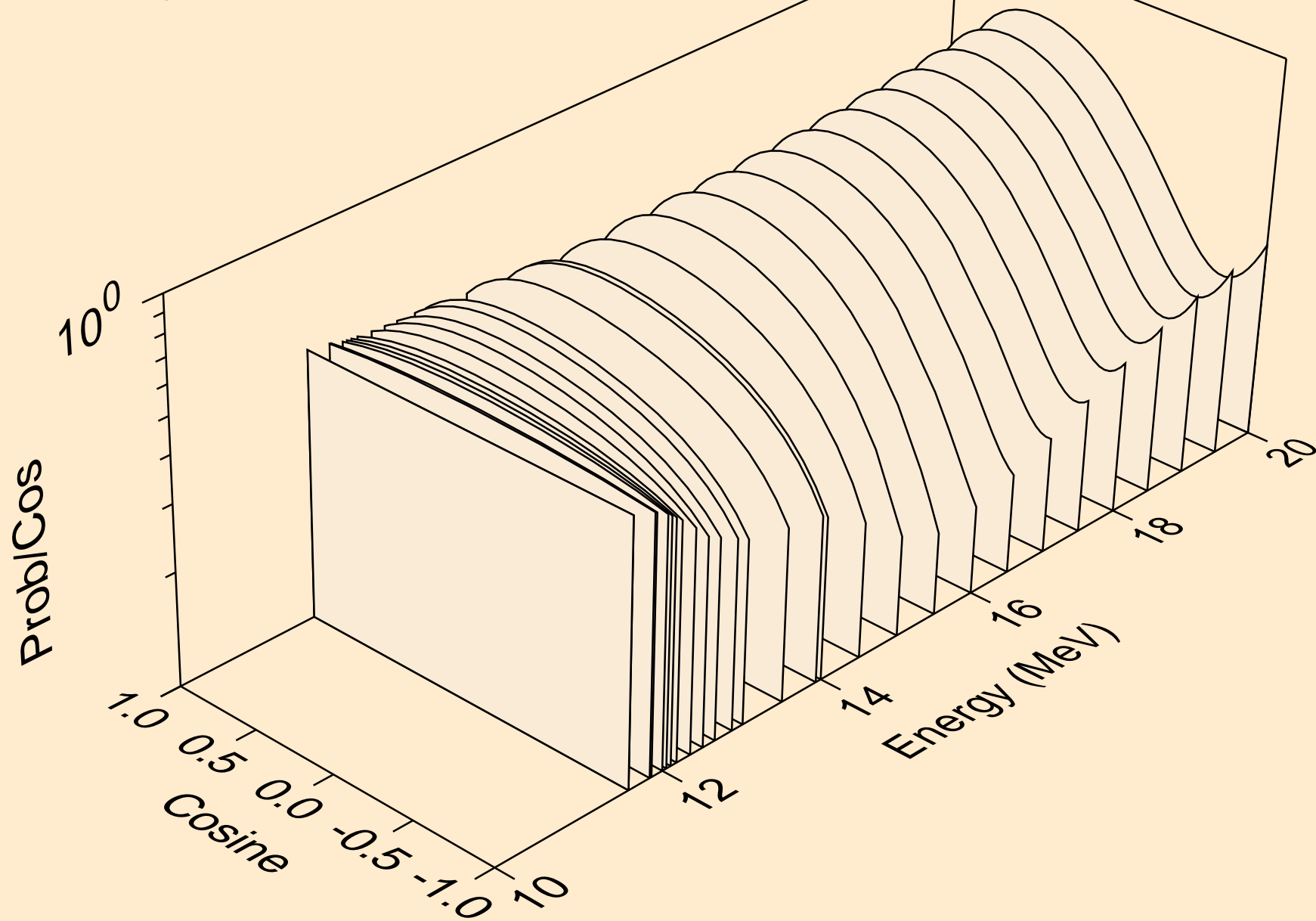

7-N-14 FOR FENDL-3.2 FROM FENDL-3.2 BY NJOY2016.60+ ON D
angular distribution for (n,n*22)

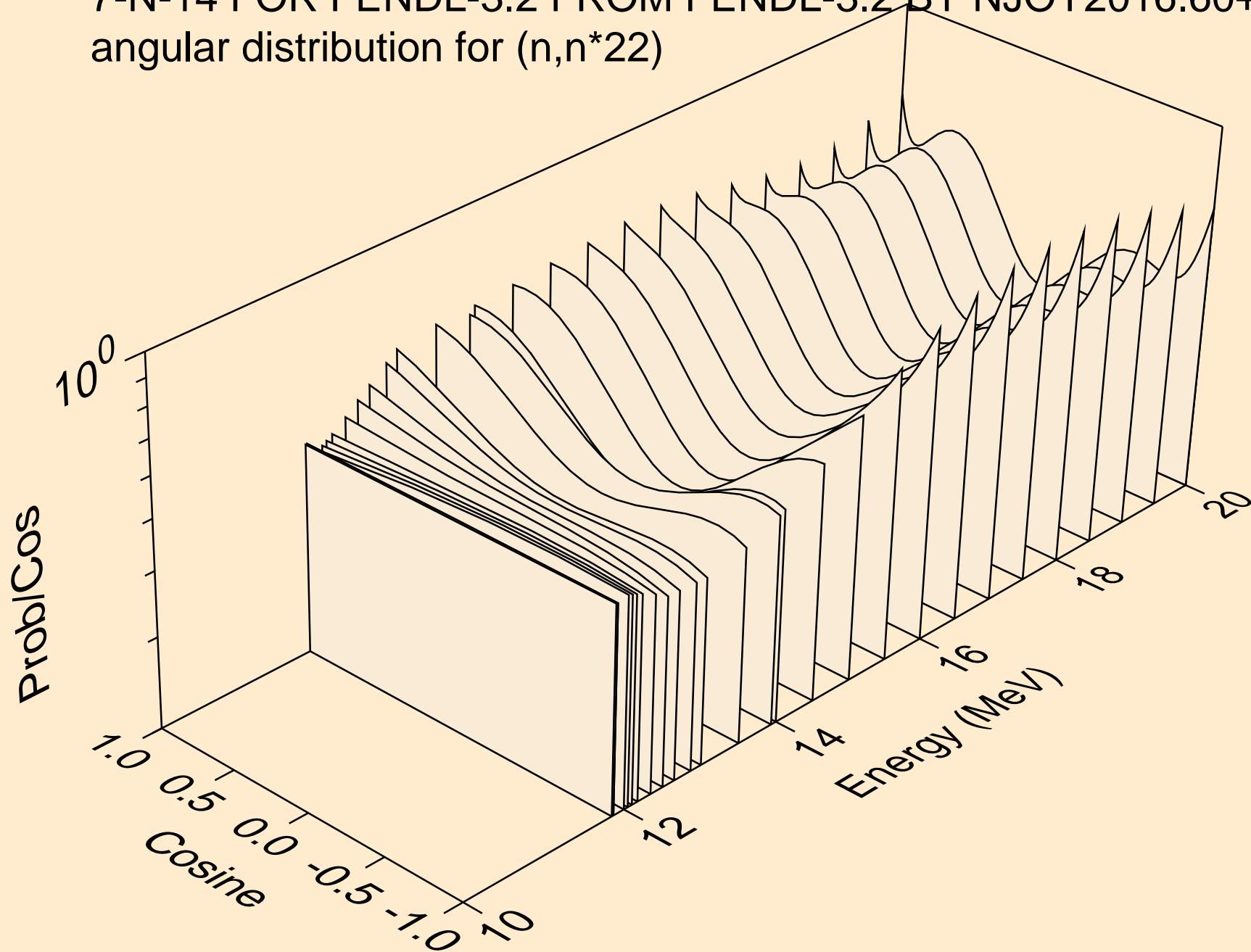

7-N-14 FOR FENDL-3.2 FROM FENDL-3.2 BY NJOY2016.60+ ON D
angular distribution for (n,n*23)

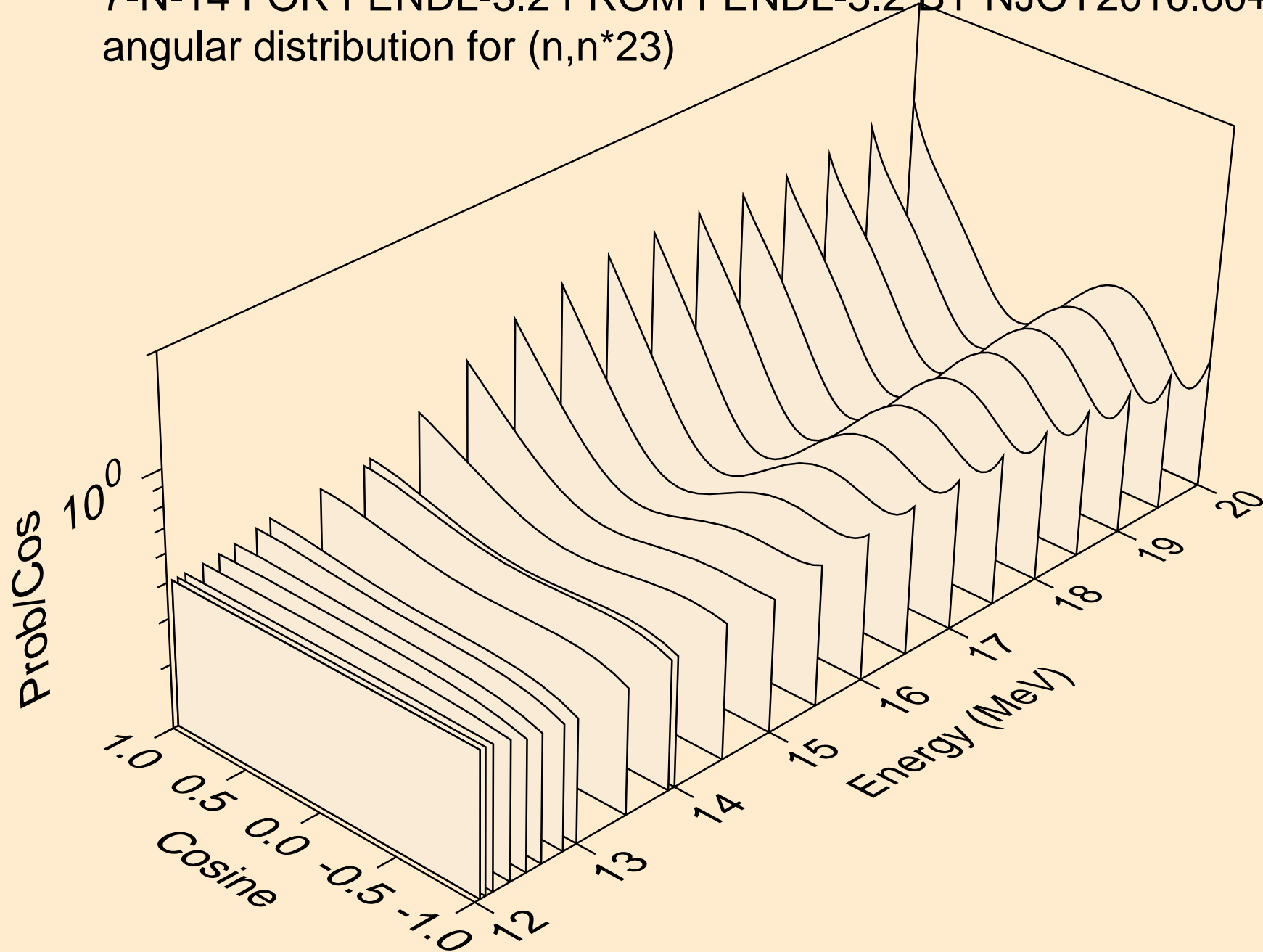

7-N-14 FOR FENDL-3.2 FROM FENDL-3.2 BY NJOY2016.60+ ON D
angular distribution for (n,n*24)

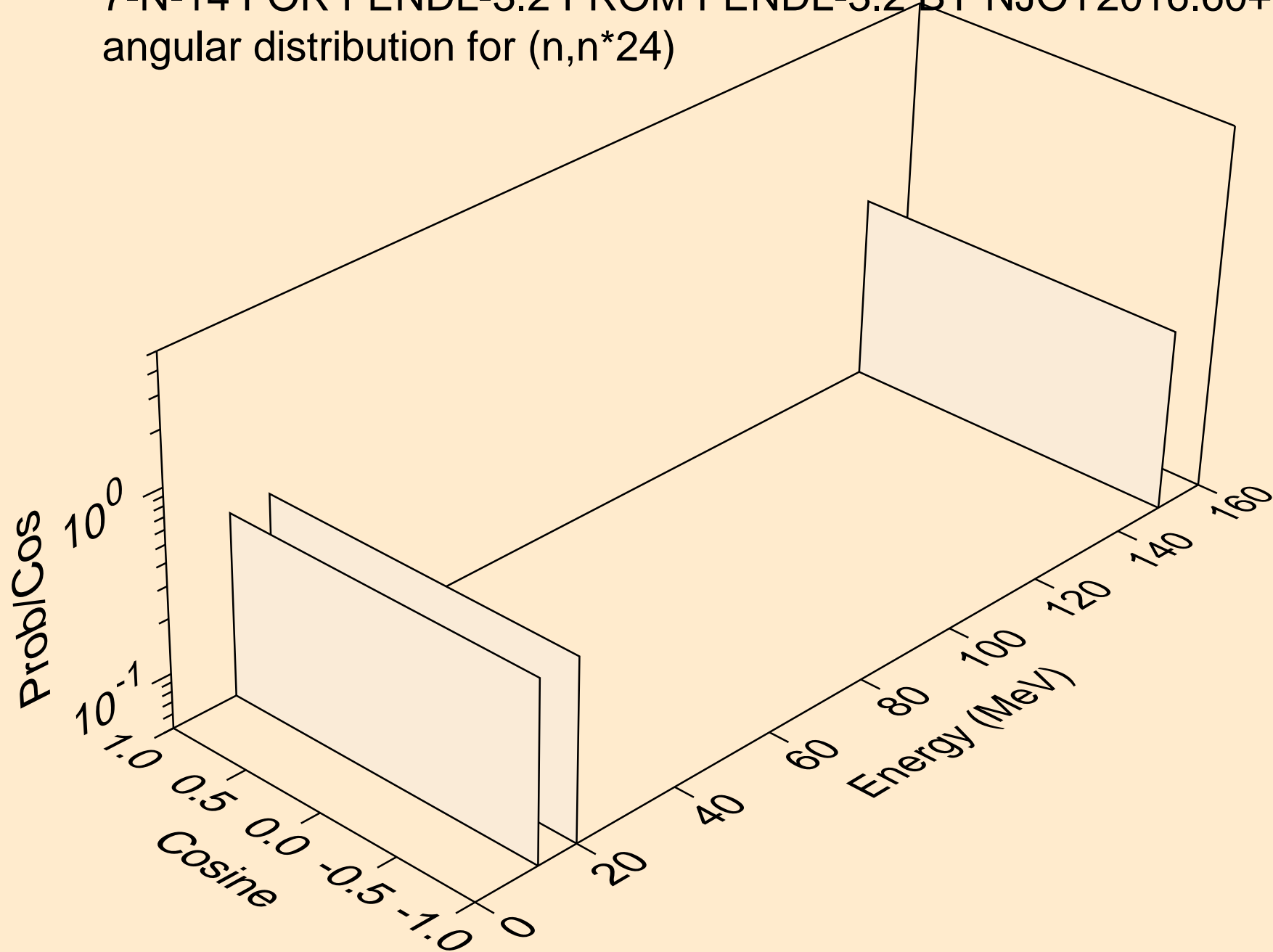

7-N-14 FOR FENDL-3.2 FROM FENDL-3.2 BY NJOY2016.60+ ON D
angular distribution for (n,n*25)

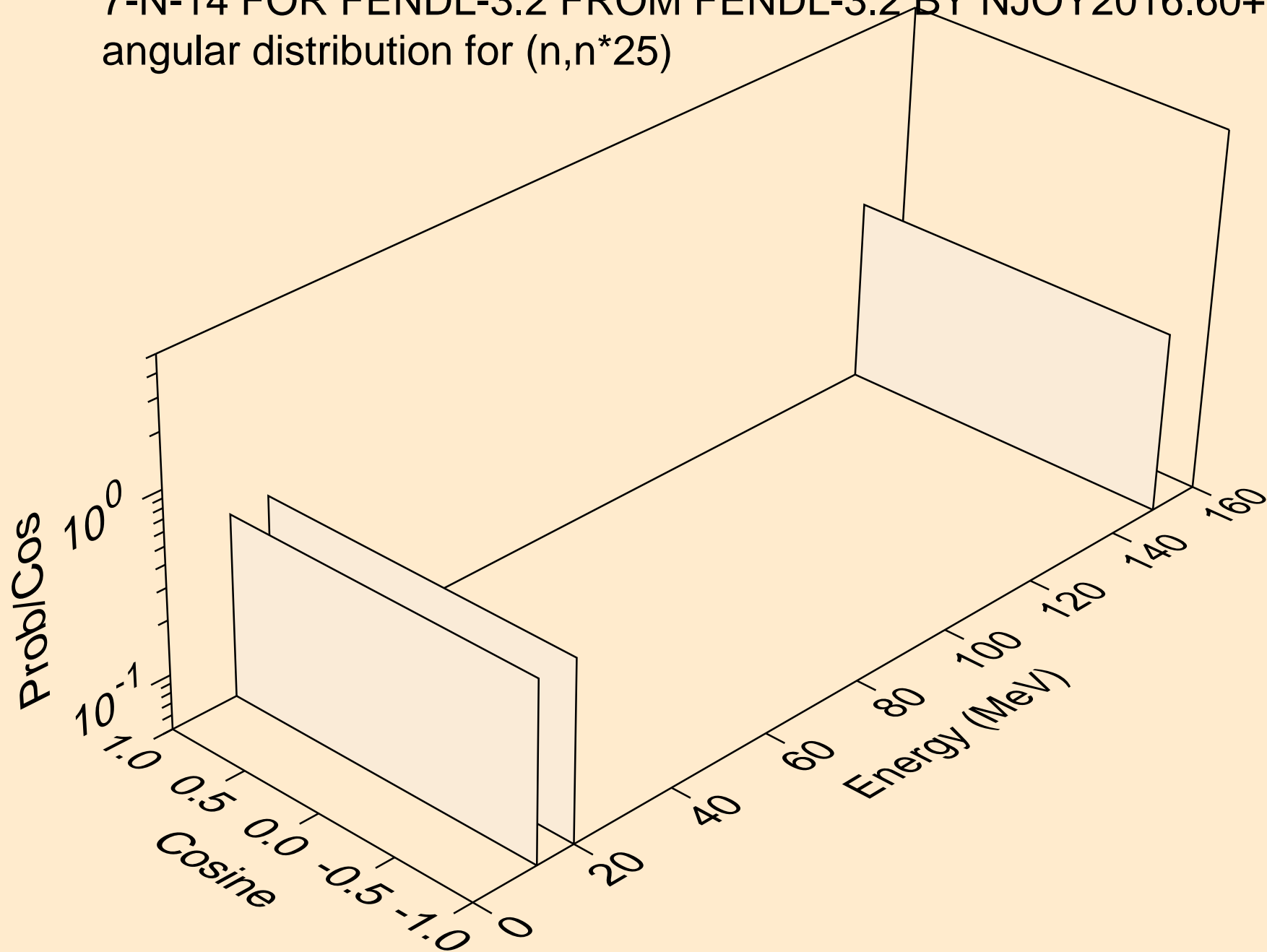

7-N-14 FOR FENDL-3.2 FROM FENDL-3.2 BY NJOY2016.60+ ON D
angular distribution for (n,n*26)

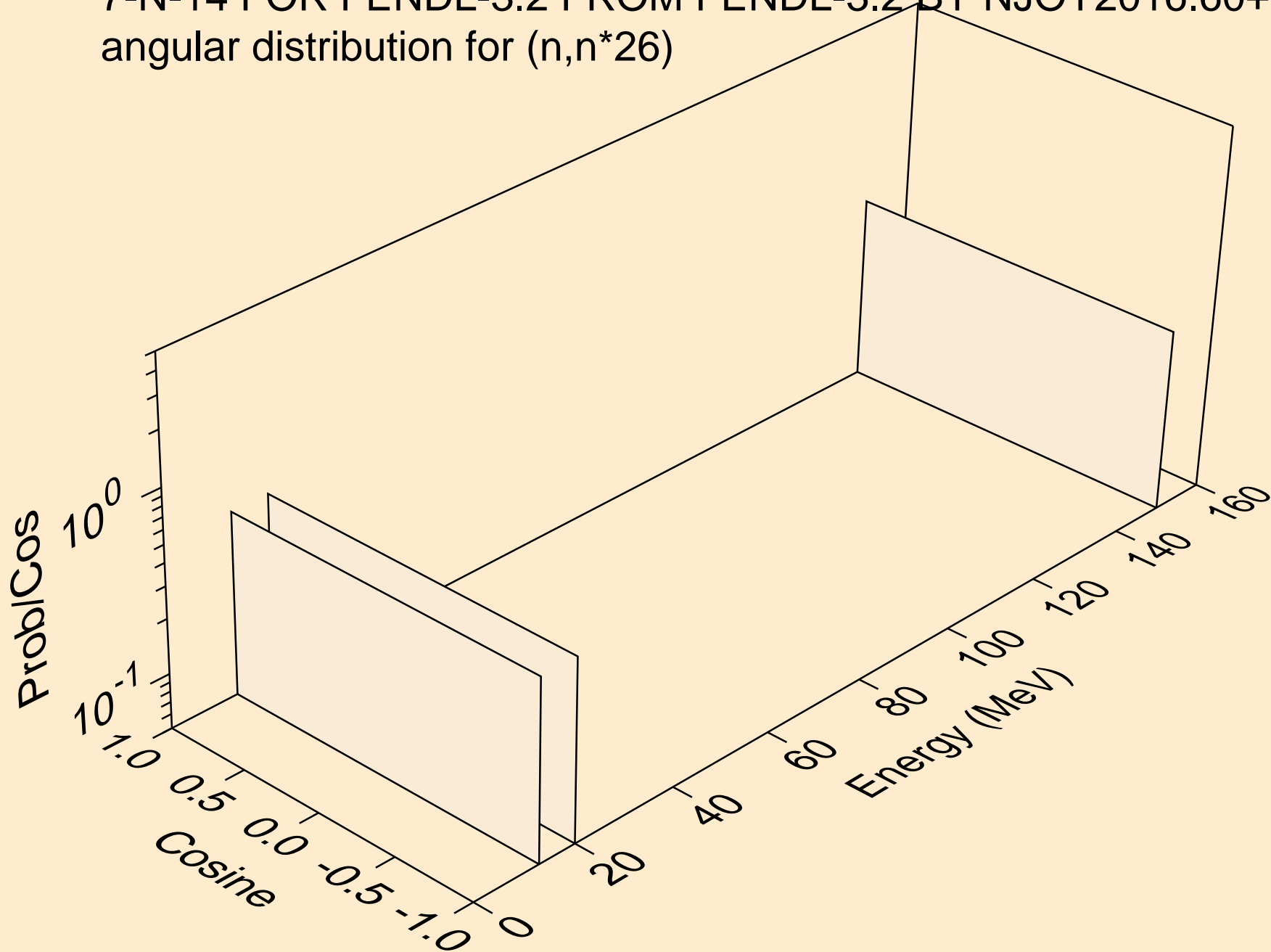

7-N-14 FOR FENDL-3.2 FROM FENDL-3.2 BY NJOY2016.60+ ON D
angular distribution for (n,n*27)

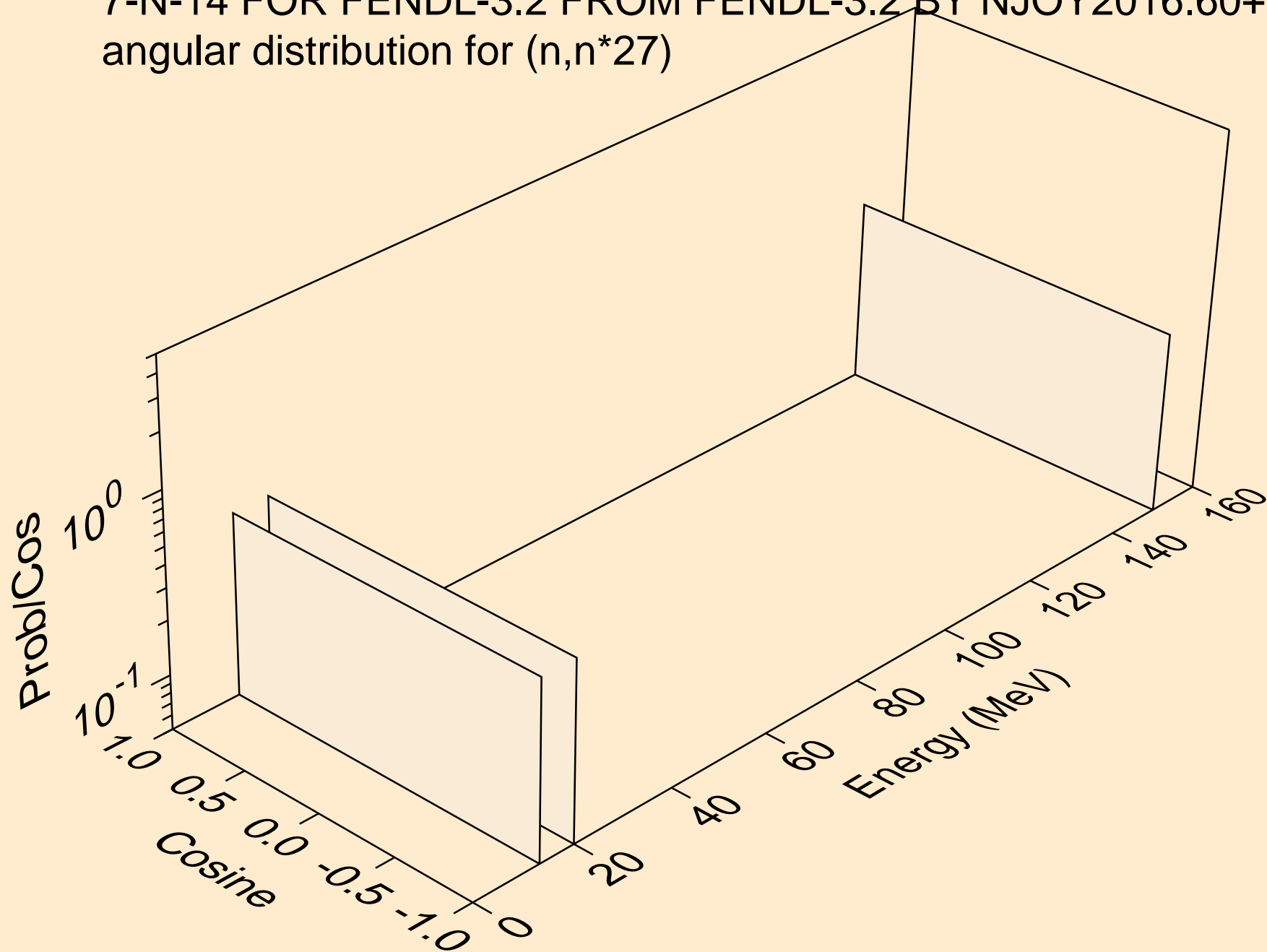

7-N-14 FOR FENDL-3.2 FROM FENDL-3.2 BY NJOY2016.60+ ON D
angular distribution for (n,n*28)

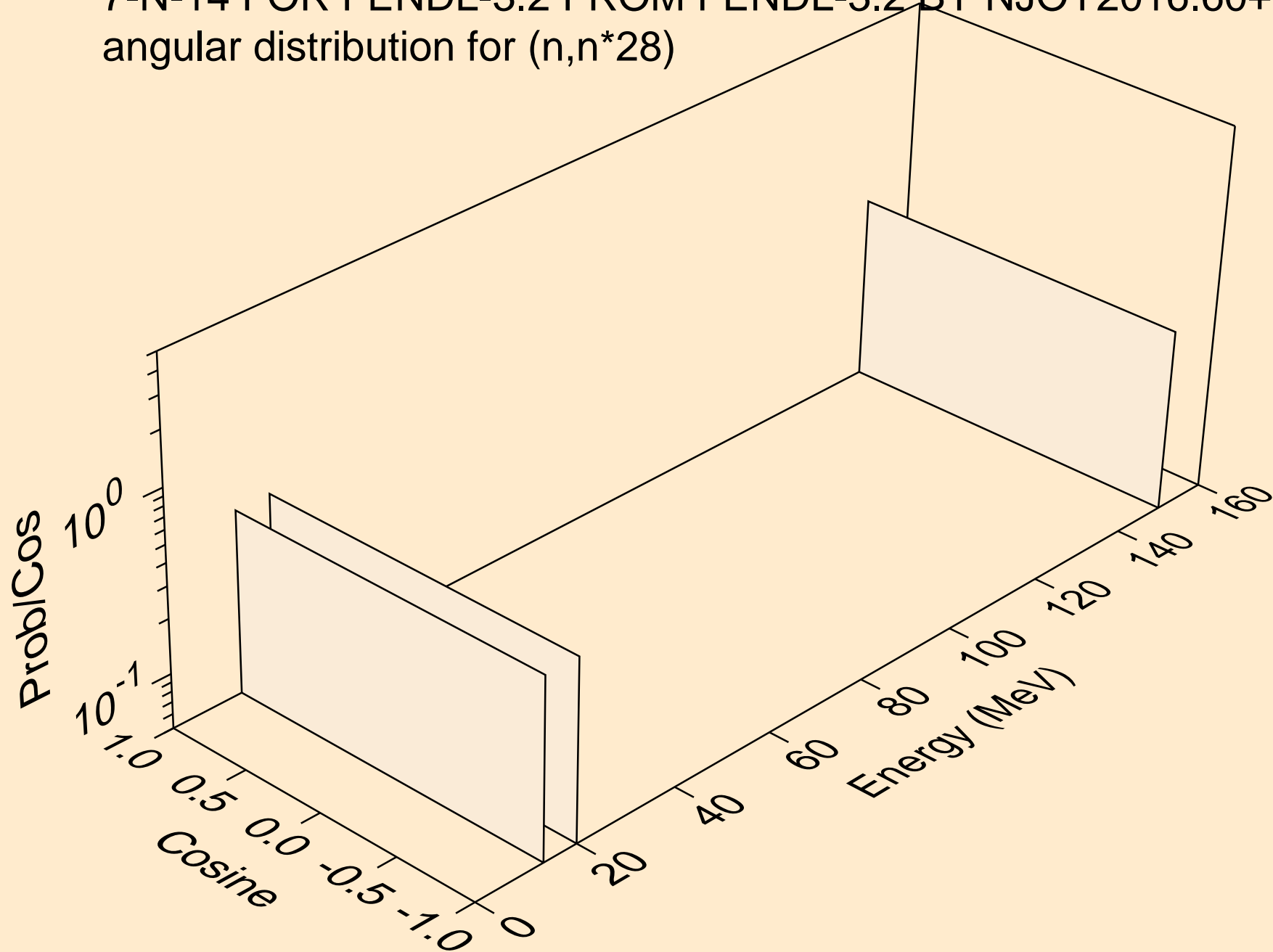

7-N-14 FOR FENDL-3.2 FROM FENDL-3.2 BY NJOY2016.60+ ON D
angular distribution for (n,n*29)

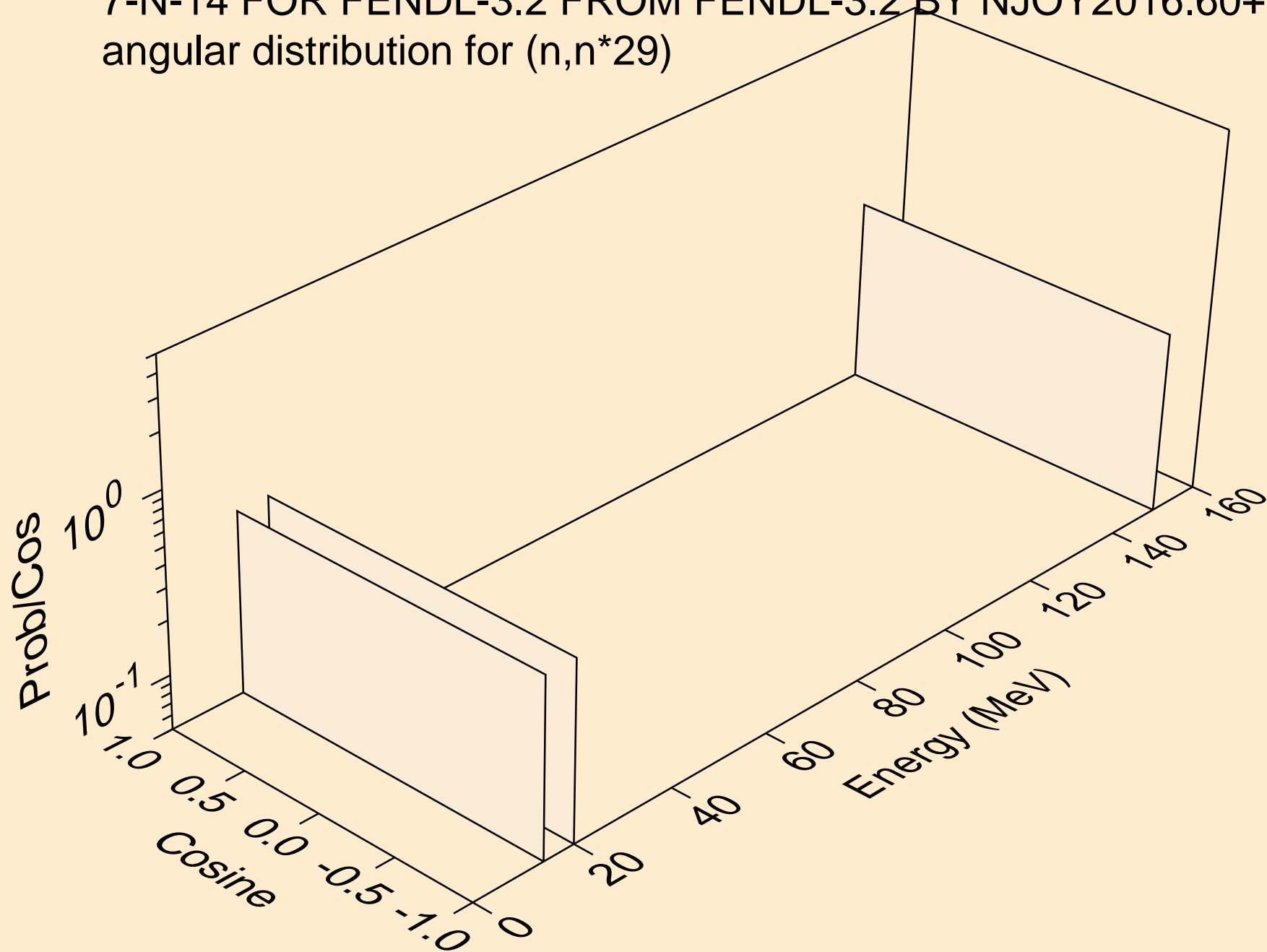

7-N-14 FOR FENDL-3.2 FROM FENDL-3.2 BY NJOY2016.60+ ON D
angular distribution for (n,n*30)

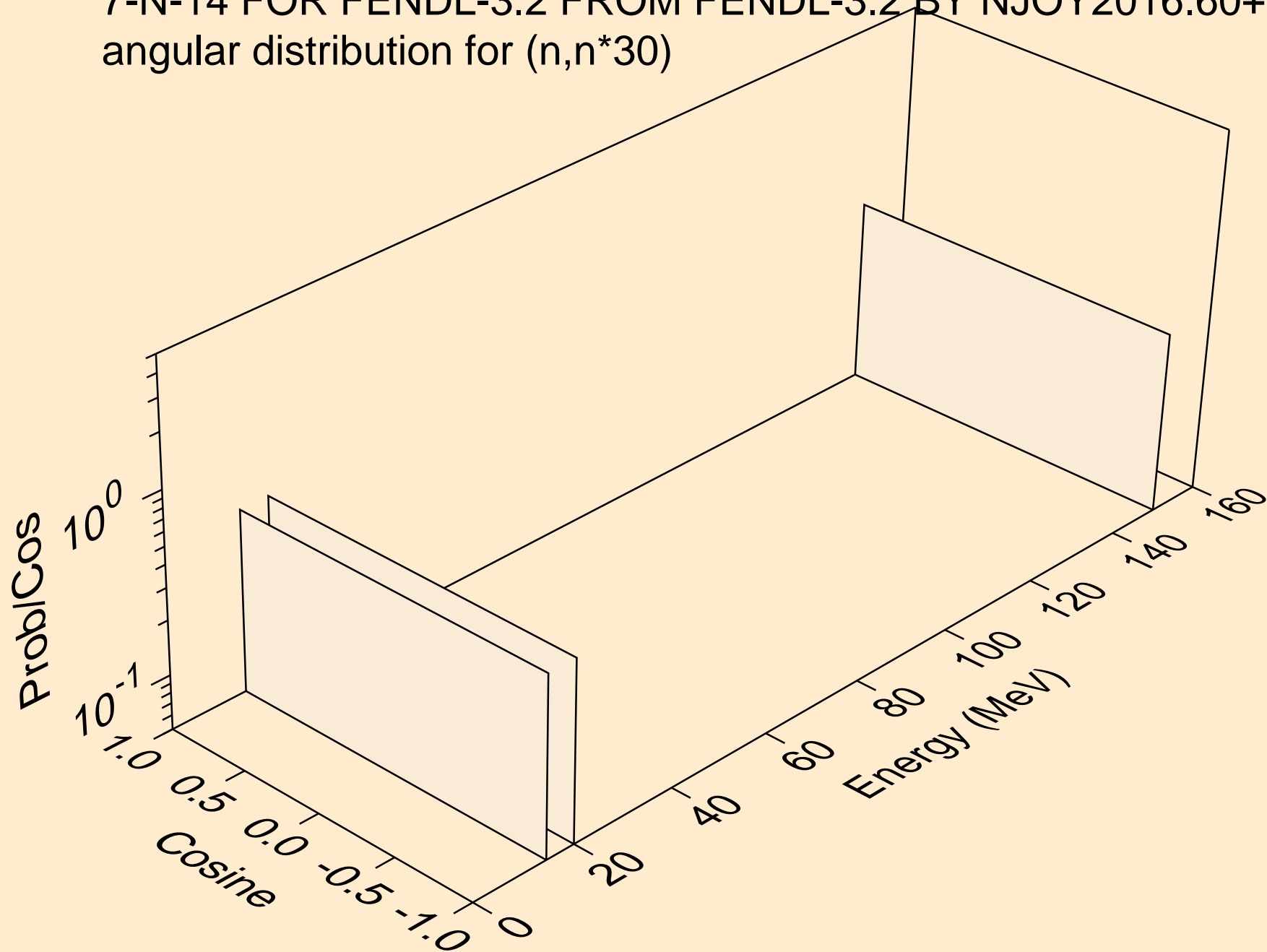

7-N-14 FOR FENDL-3.2 FROM FENDL-3.2 BY NJOY2016.60+ ON D
angular distribution for (n,n*31)

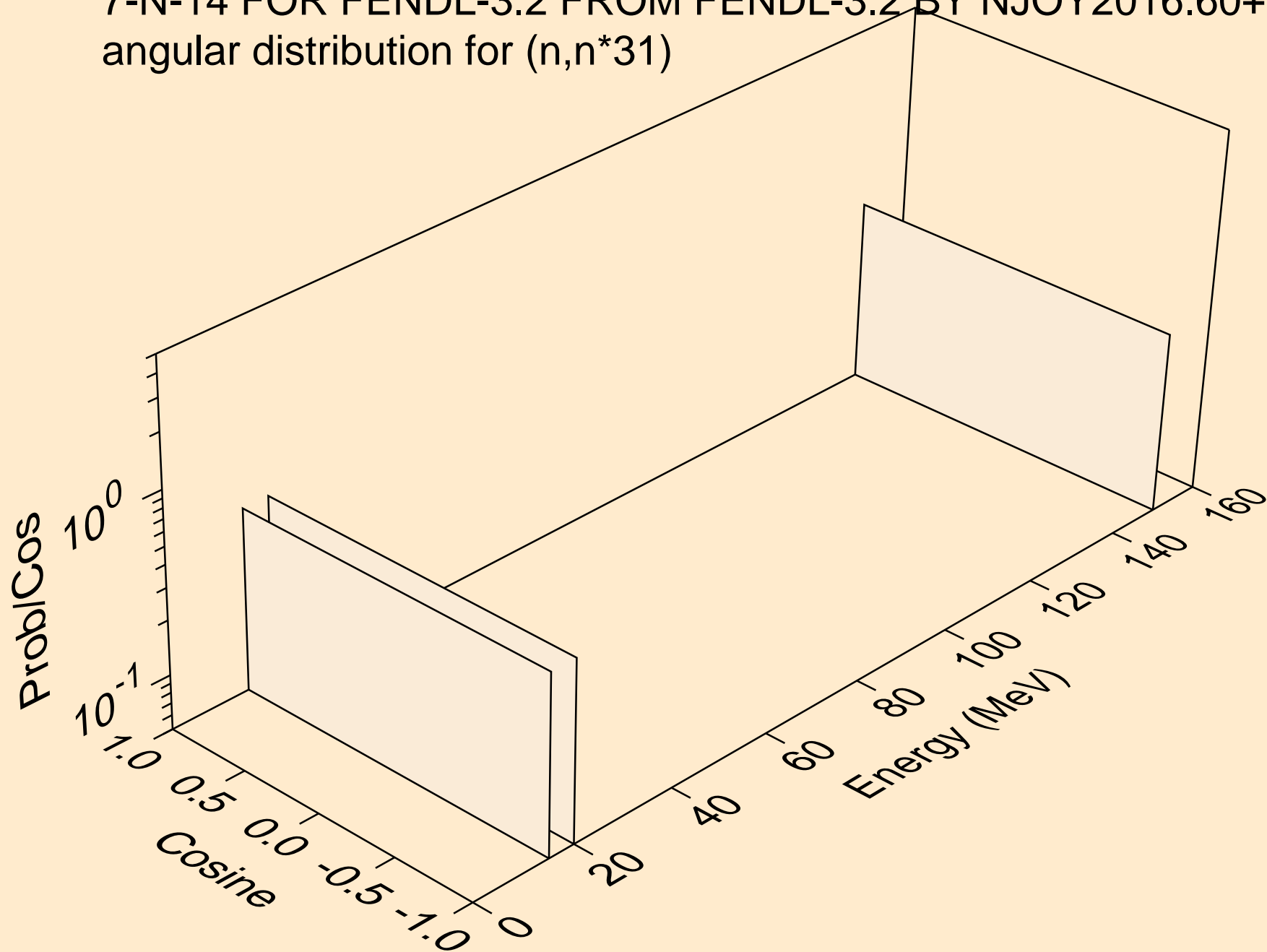

7-N-14 FOR FENDL-3.2 FROM FENDL-3.2 BY NJOY2016.60+ ON D
angular distribution for (n,n*32)

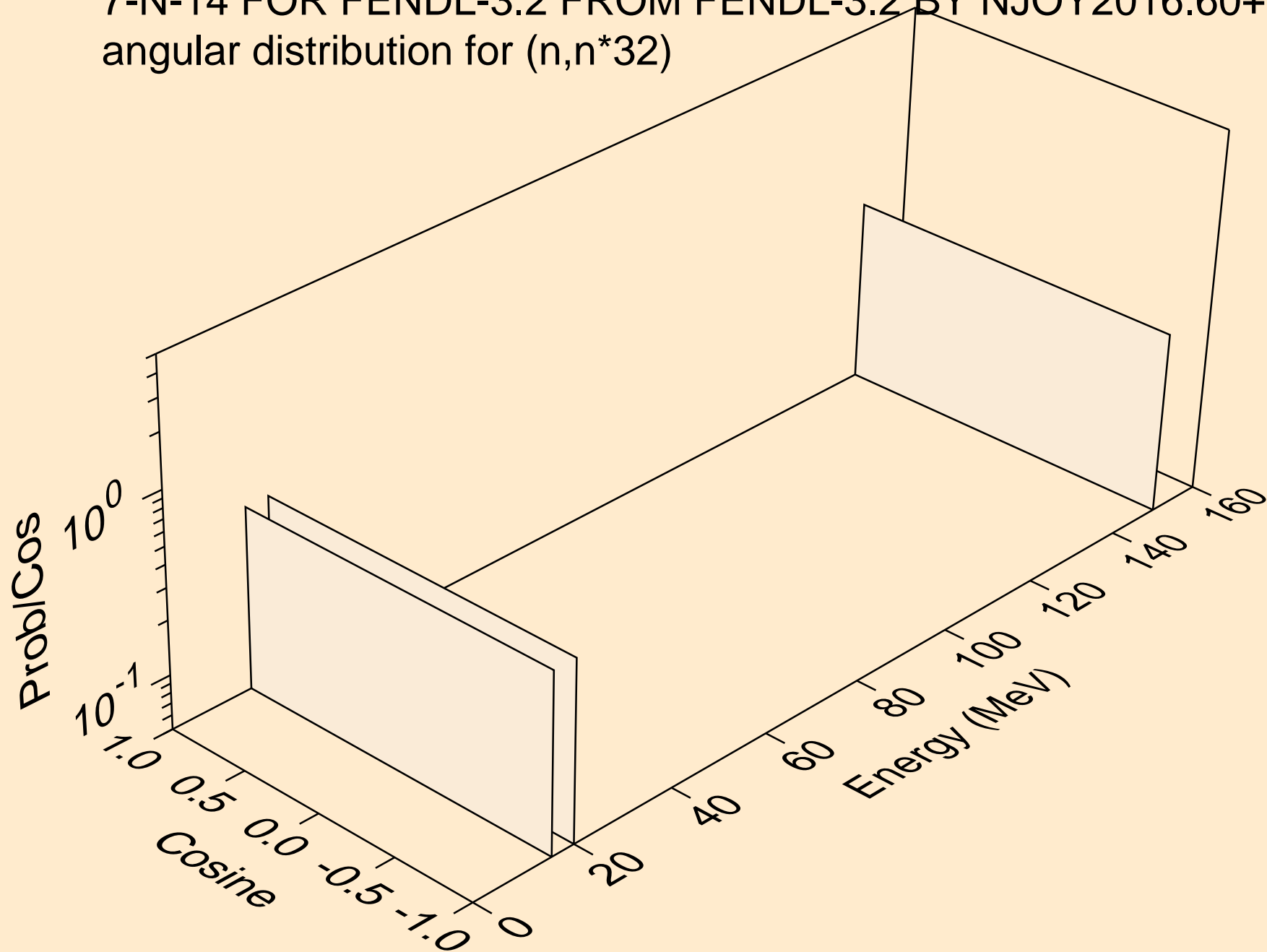

7-N-14 FOR FENDL-3.2 FROM FENDL-3.2 BY NJOY2016.60+ ON D
angular distribution for (n,n*33)

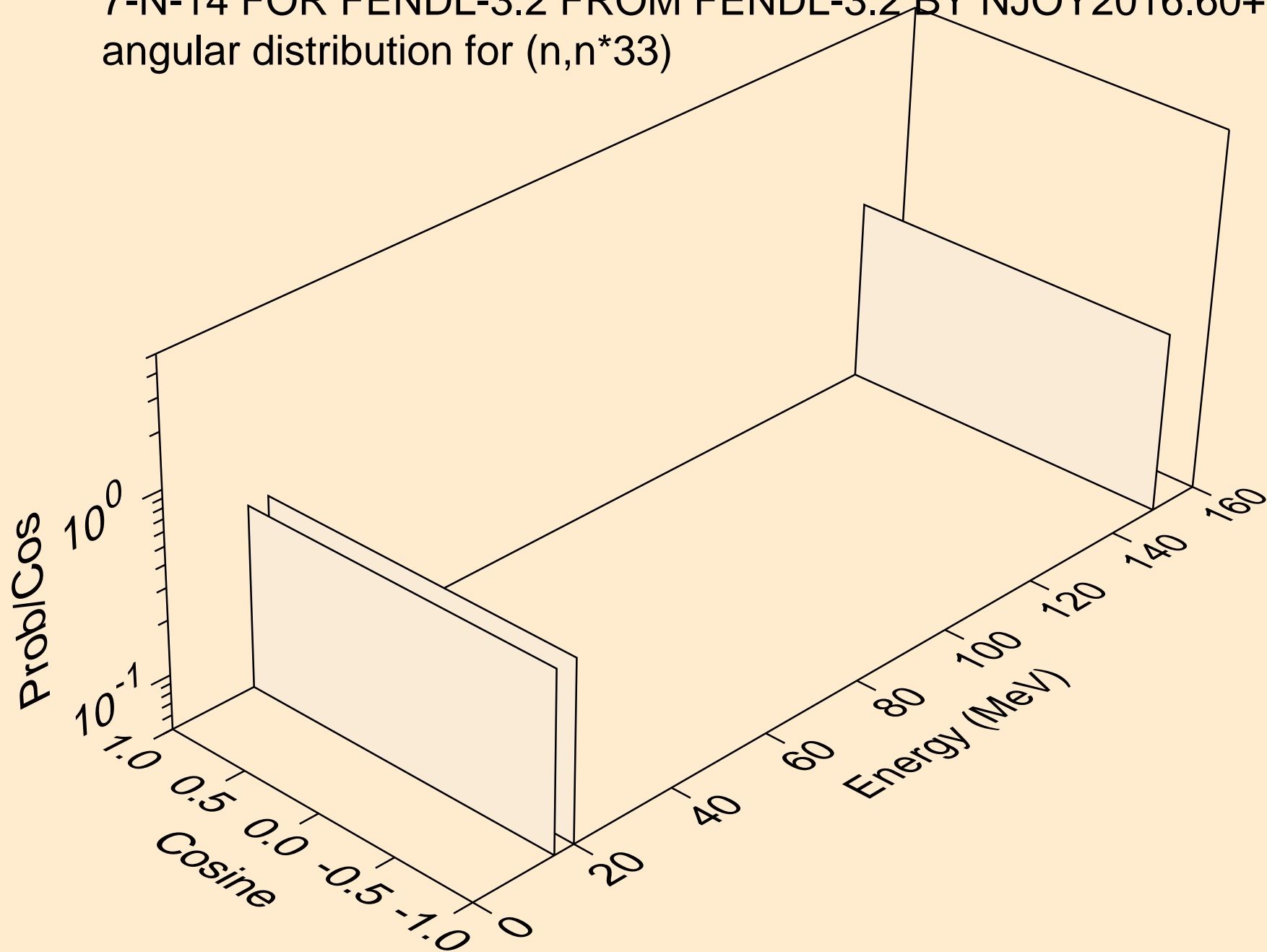

7-N-14 FOR FENDL-3.2 FROM FENDL-3.2 BY NJOY2016.60+ ON D
angular distribution for (n,n*34)

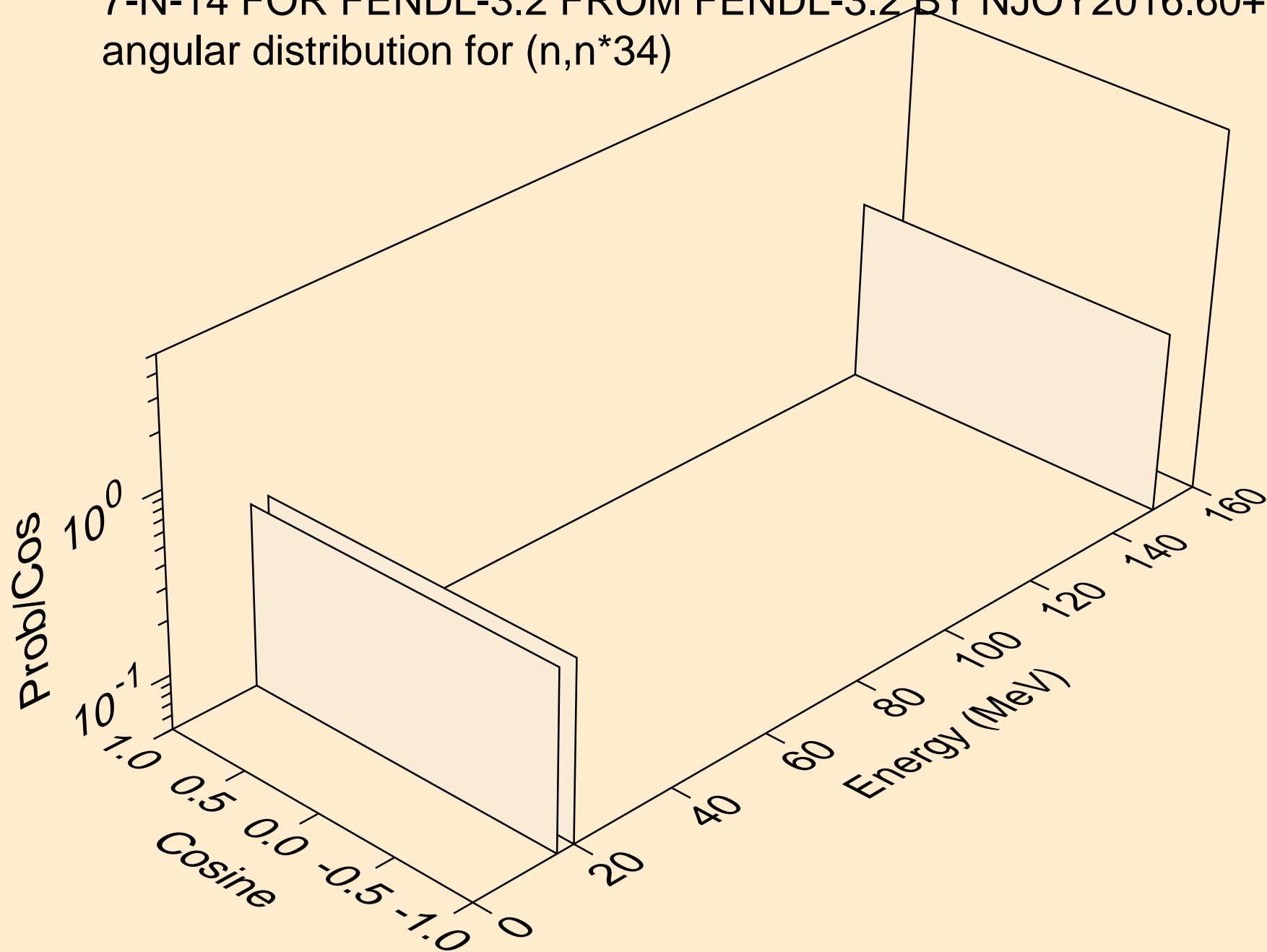

7-N-14 FOR FENDL-3.2 FROM FENDL-3.2 BY NJOY2016.60+ ON D
angular distribution for (n,n*35)

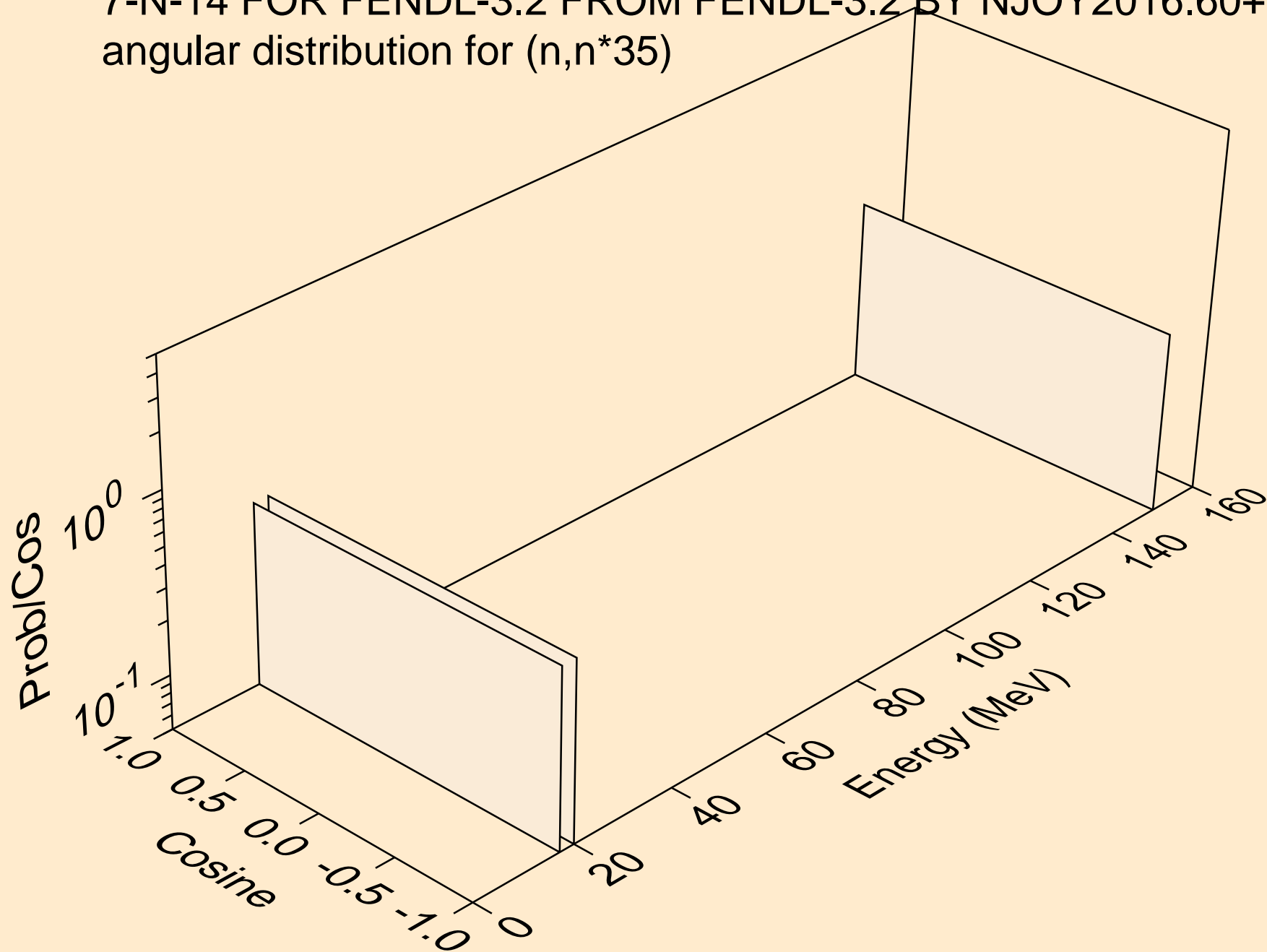

7-N-14 FOR FENDL-3.2 FROM FENDL-3.2 BY NJOY2016.60+ ON D
angular distribution for (n,n*36)

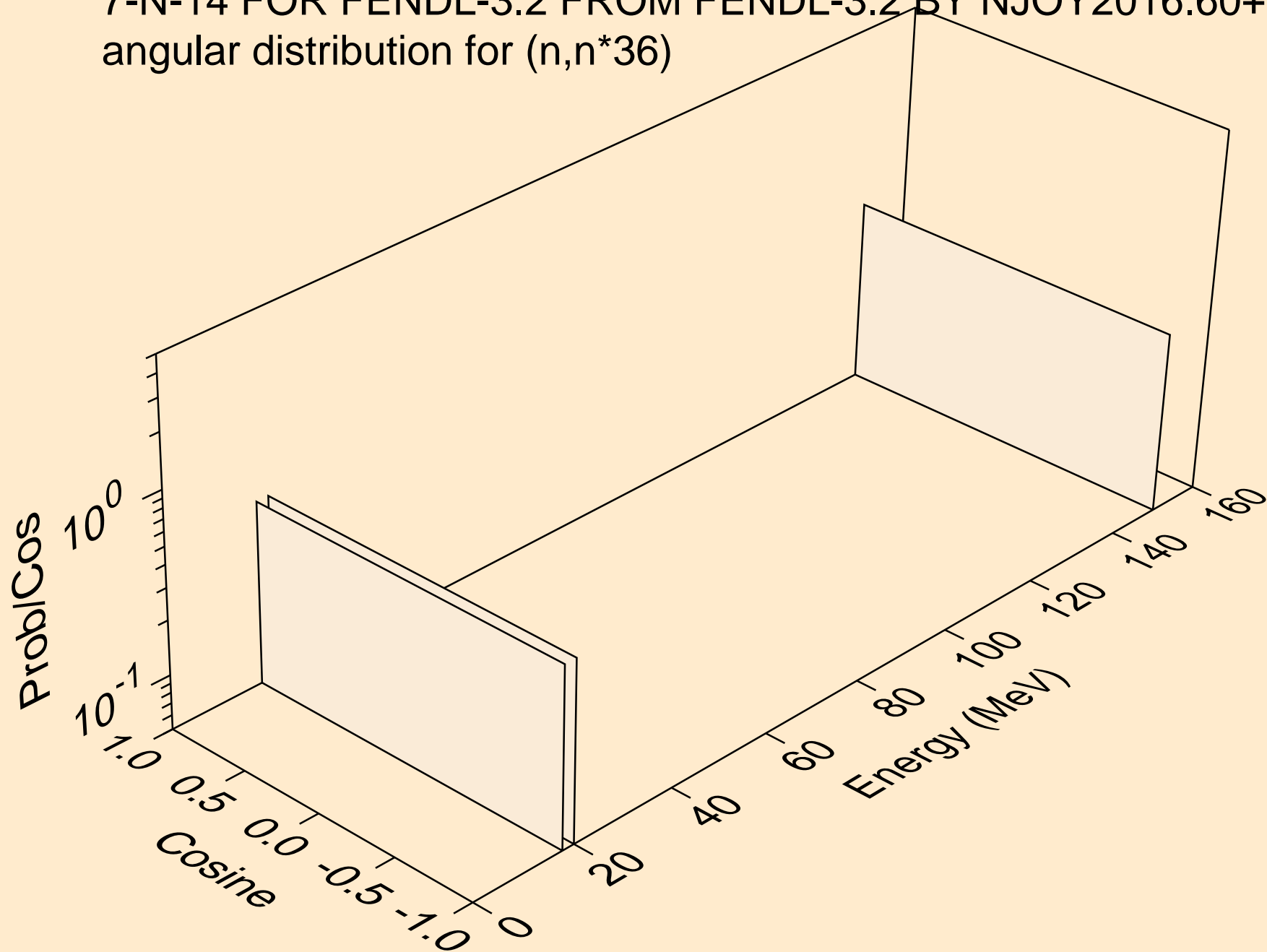

7-N-14 FOR FENDL-3.2 FROM FENDL-3.2 BY NJOY2016.60+ ON D
angular distribution for (n,n*37)

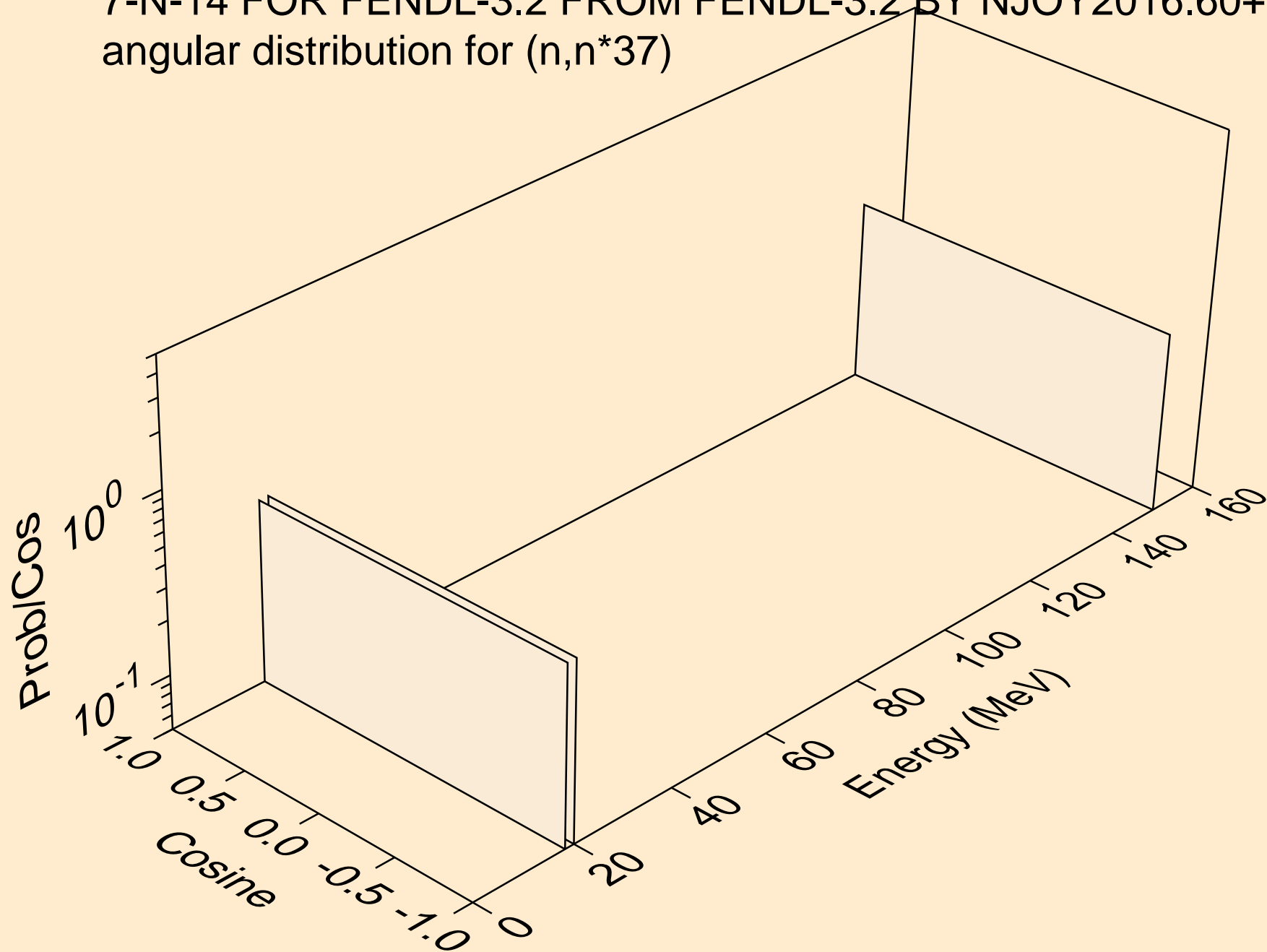

7-N-14 FOR FENDL-3.2 FROM FENDL-3.2 BY NJOY2016.60+ ON D
angular distribution for (n,n*38)

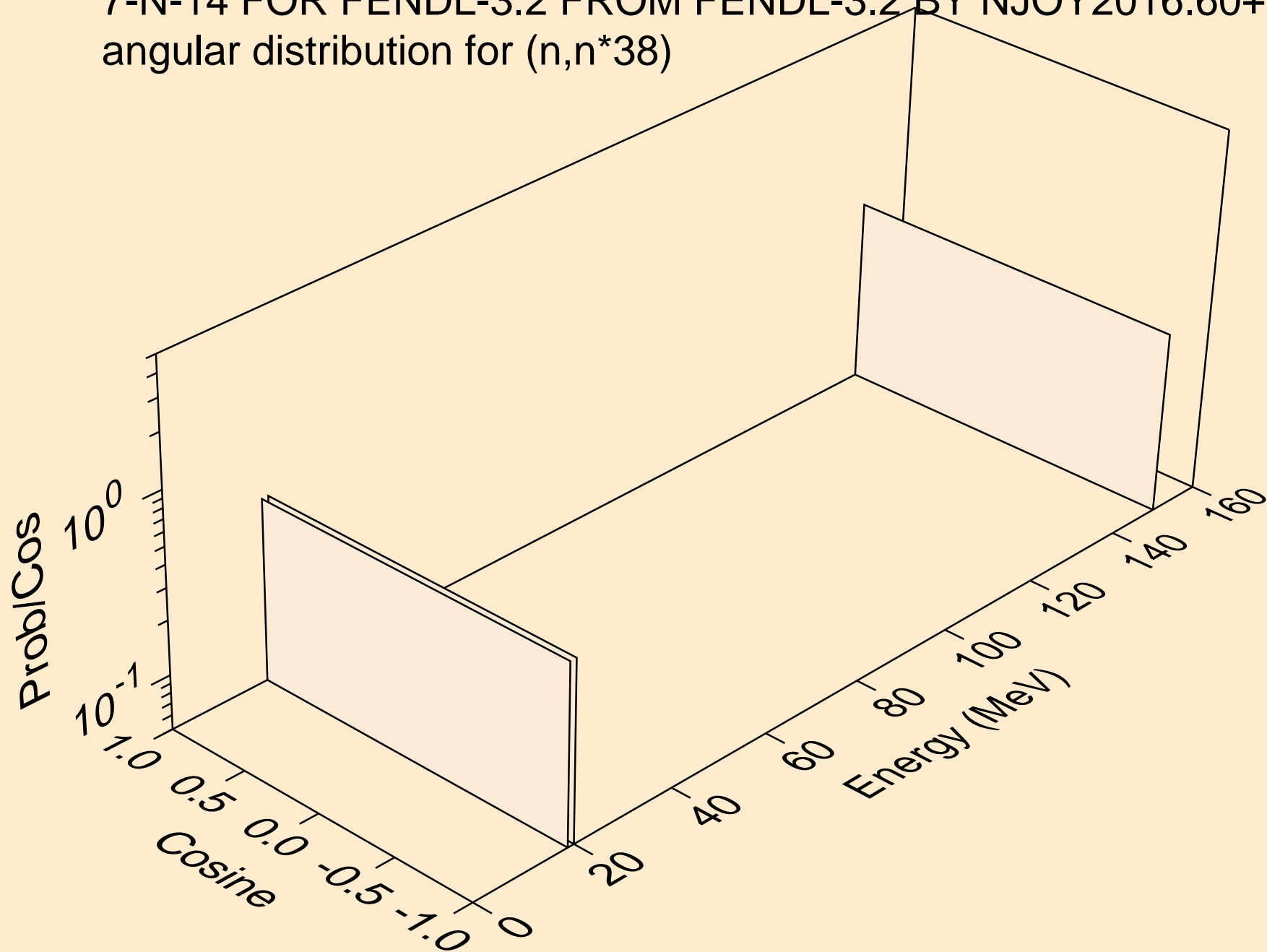

7-N-14 FOR FENDL-3.2 FROM FENDL-3.2 BY NJOY2016.60+ ON D
angular distribution for (n,n*39)

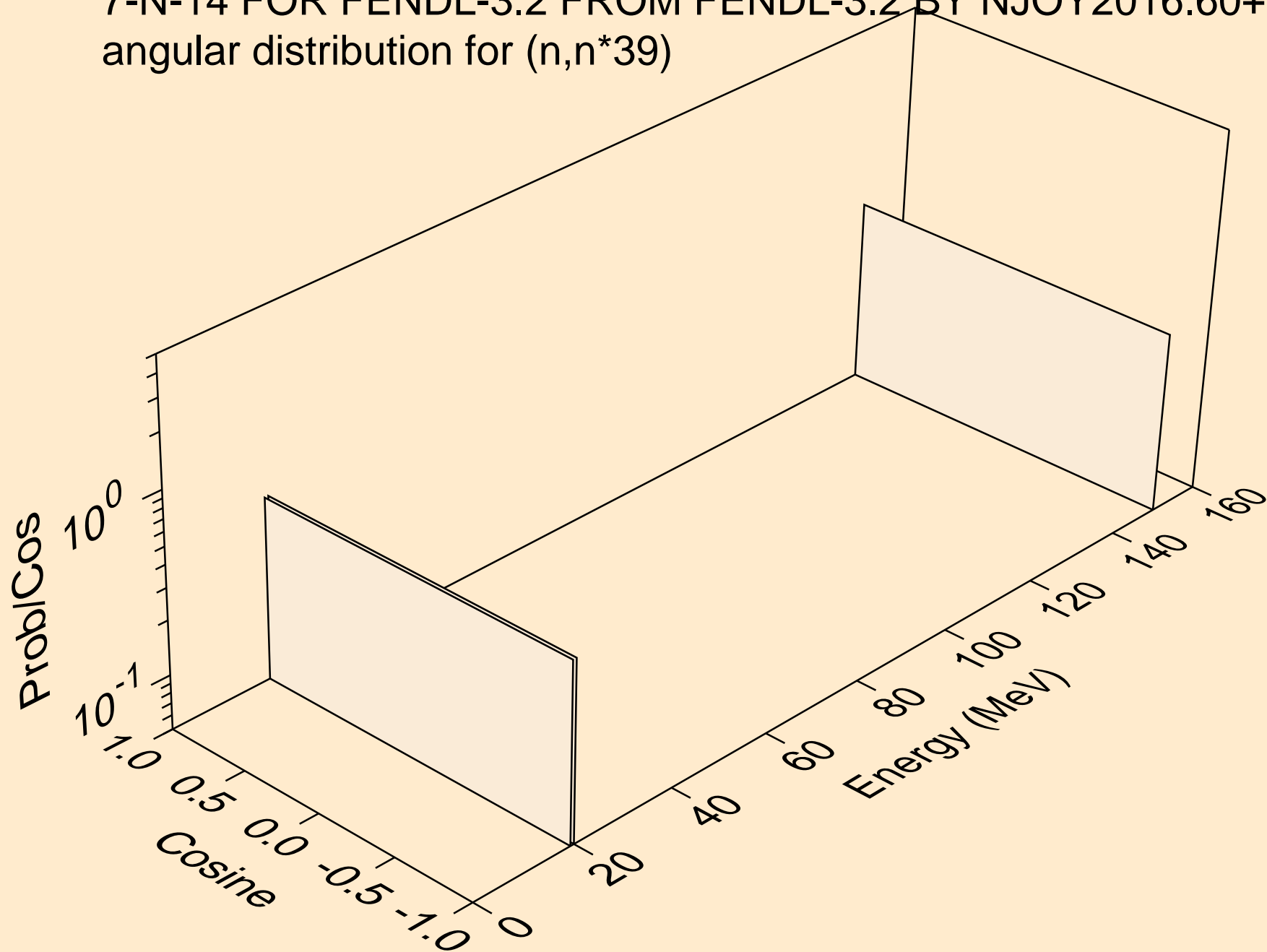

7-N-14 FOR FENDL-3.2 FROM FENDL-3.2 BY NJOY2016.60+ ON D
angular distribution for (n,n*40)

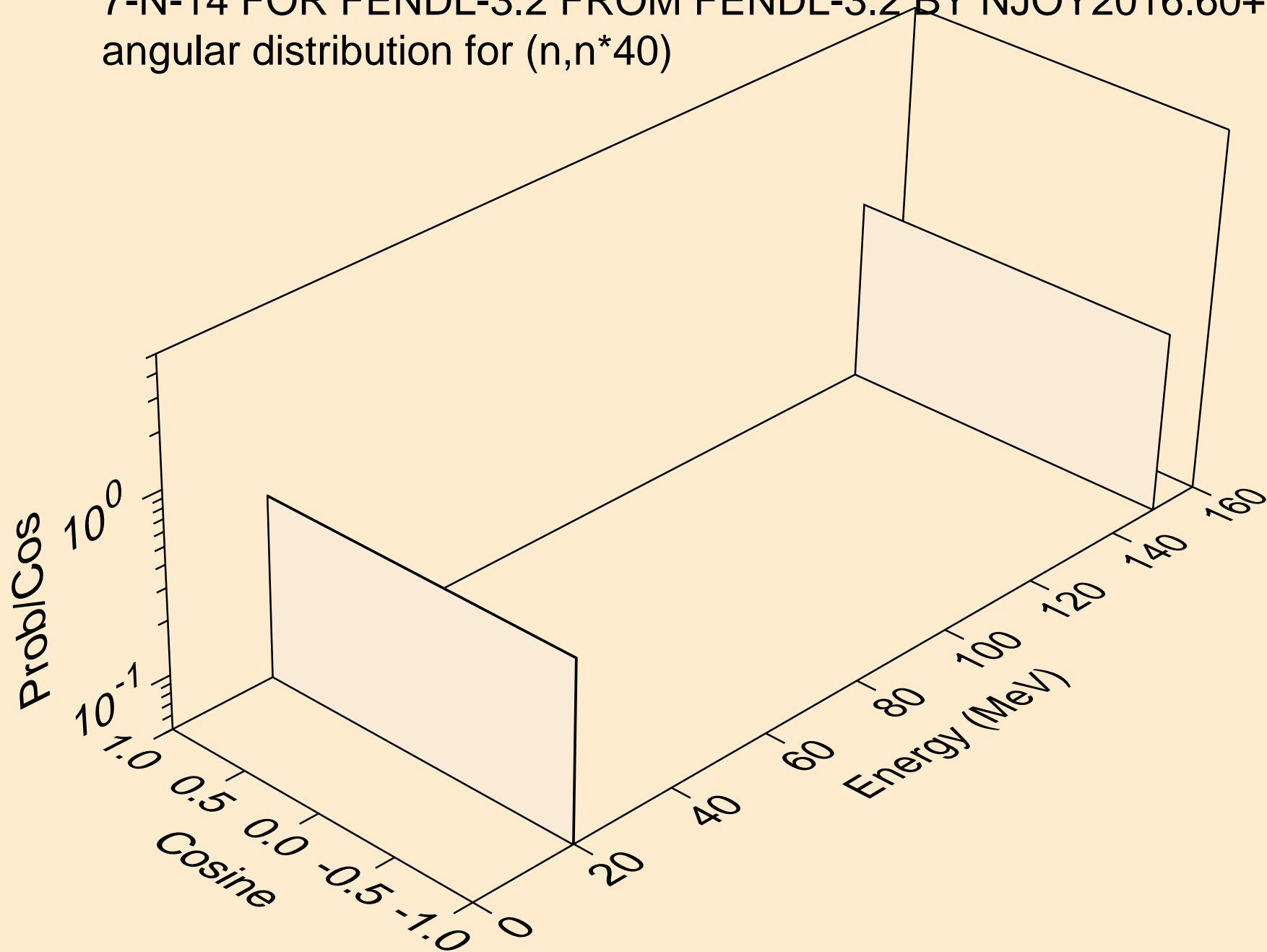

7-N-14 FOR FENDL-3.2 FROM FENDL-3.2 BY NJOY2016.60+ ON D
Neutron emission for (n,x)

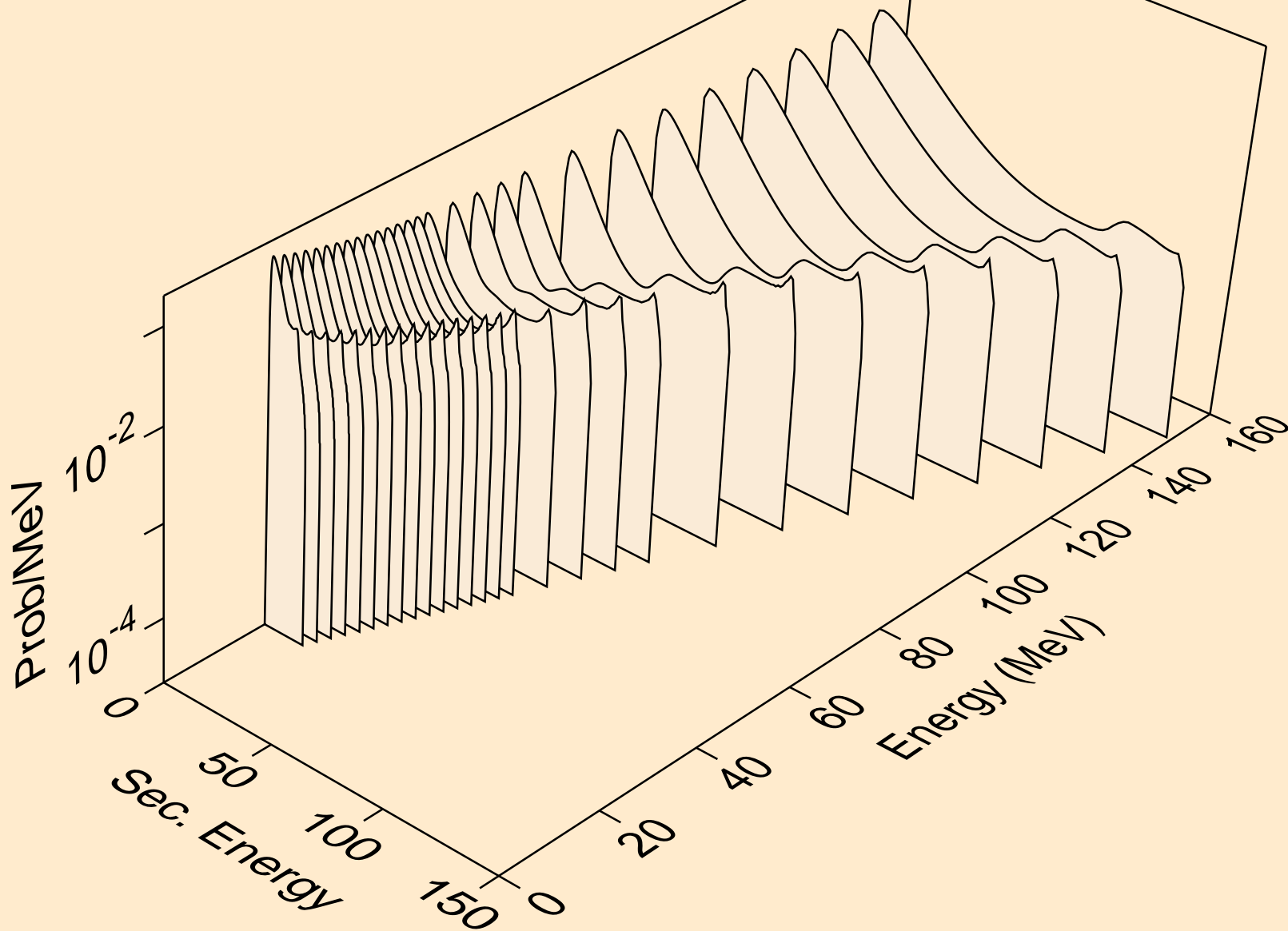

7-N-14 FOR FENDL-3.2 FROM FENDL-3.2 BY NJOY2016.60+ ON D
Neutron emission for (n,2n)

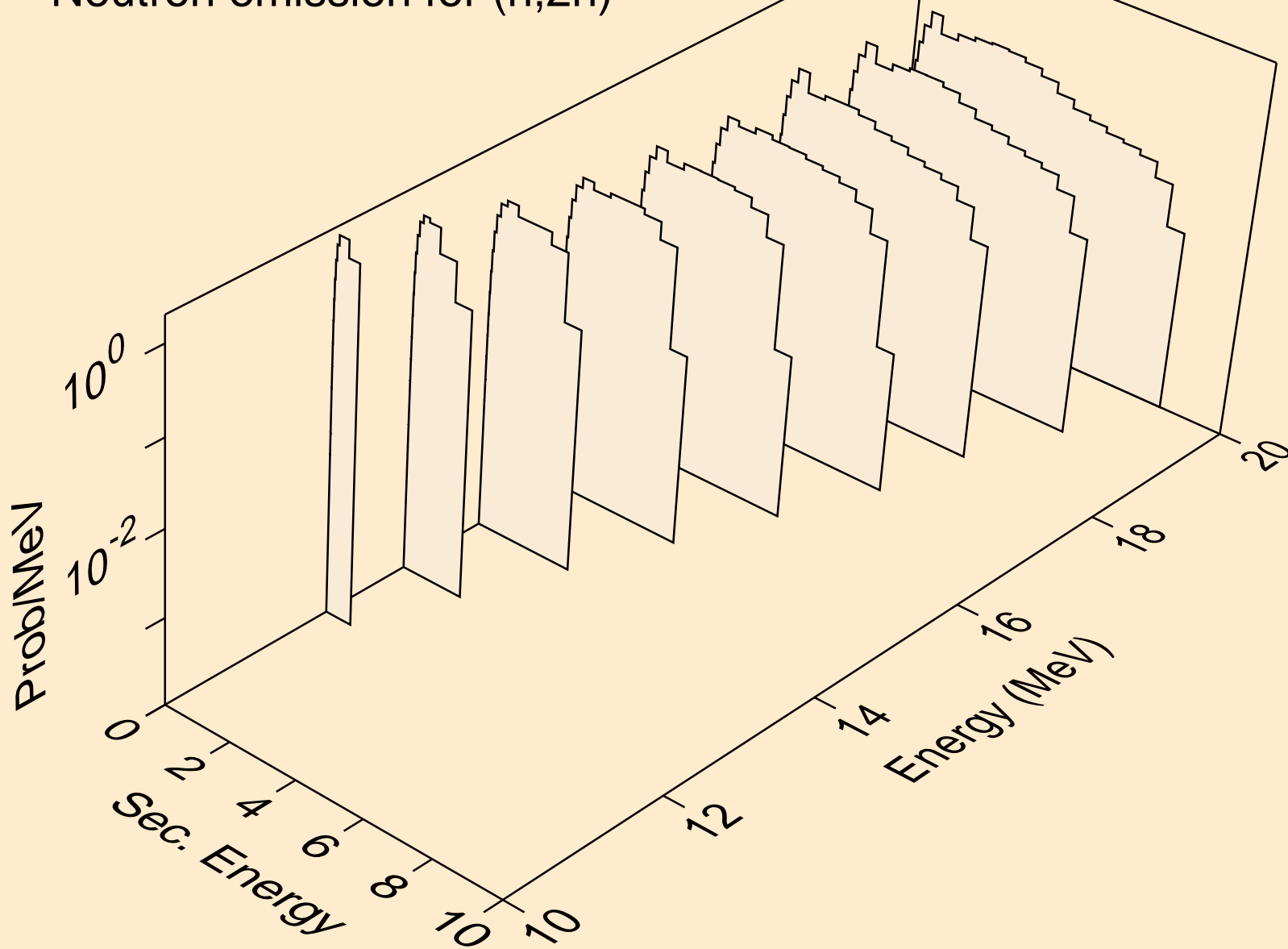

7-N-14 FOR FENDL-3.2 FROM FENDL-3.2 BY NJOY2016.60+ ON D
Neutron emission for (n,n*)a

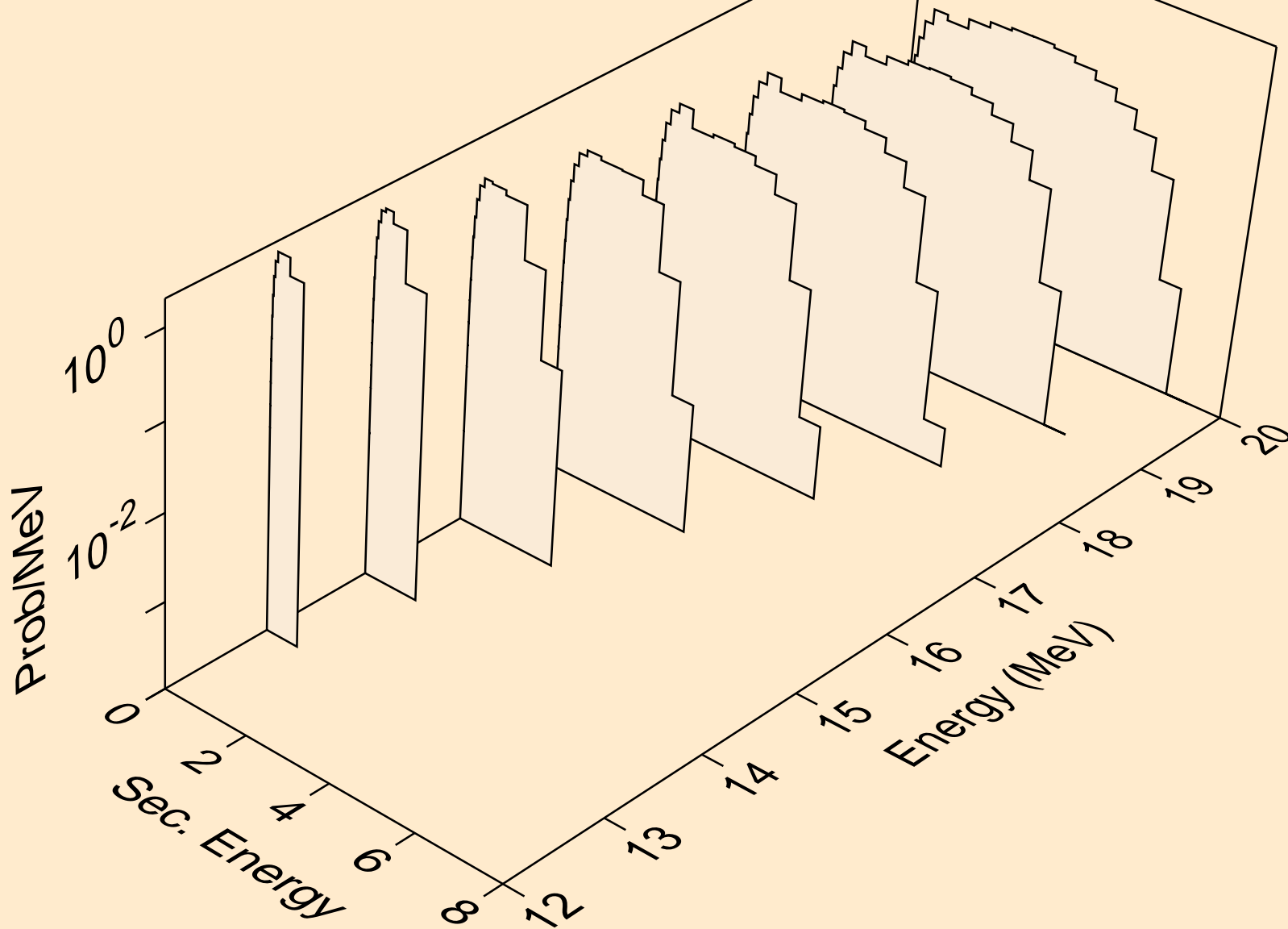

7-N-14 FOR FENDL-3.2 FROM FENDL-3.2 BY NJOY2016.60+ ON D
Neutron emission for (n,n*)p

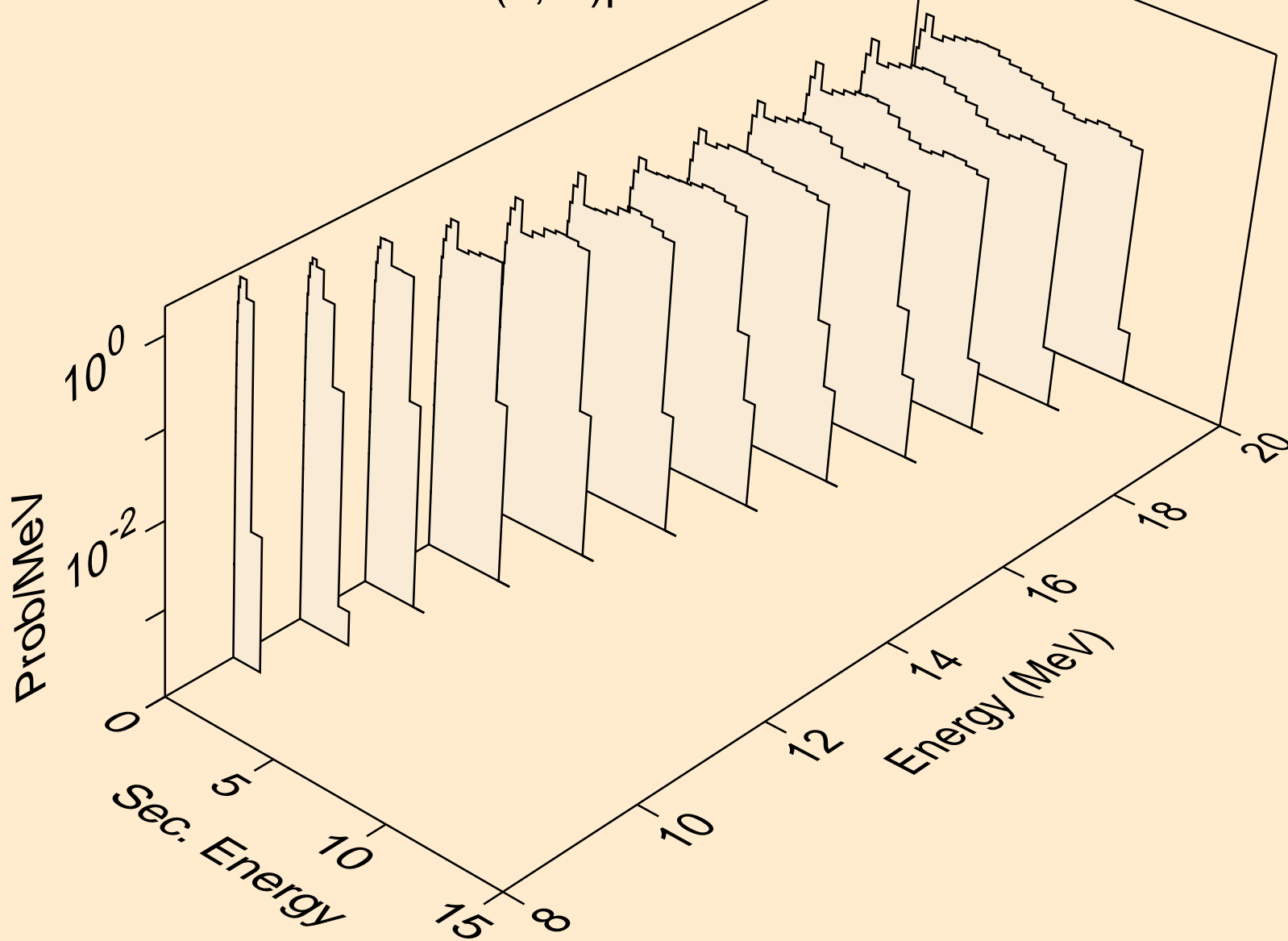

7-N-14 FOR FENDL-3.2 FROM FENDL-3.2 BY NJOY2016.60+ ON D
Neutron emission for (n,n*)d

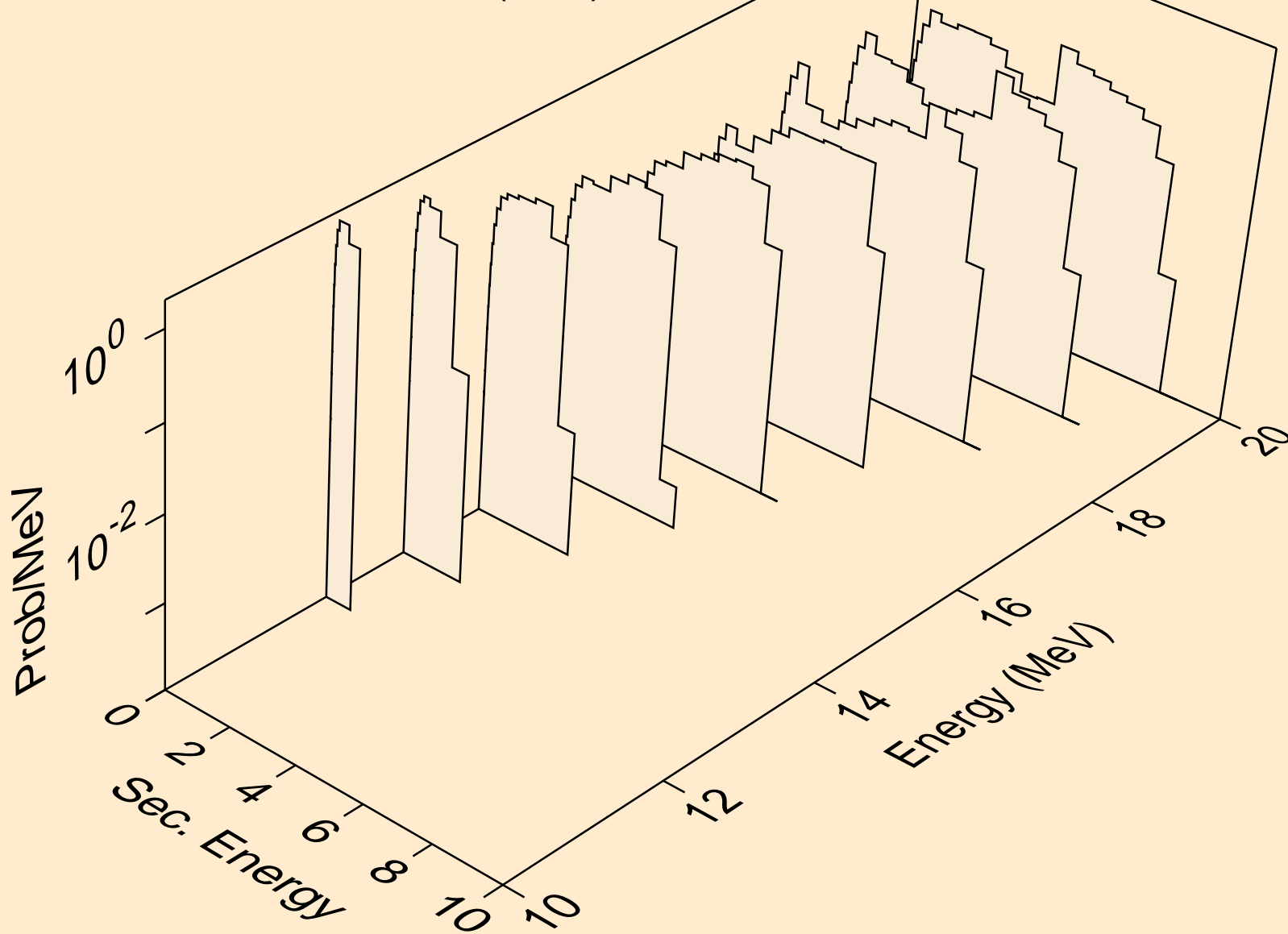

7-N-14 FOR FENDL-3.2 FROM FENDL-3.2 BY NJOY2016.60+ ON D
Photon emission for (n,gma)

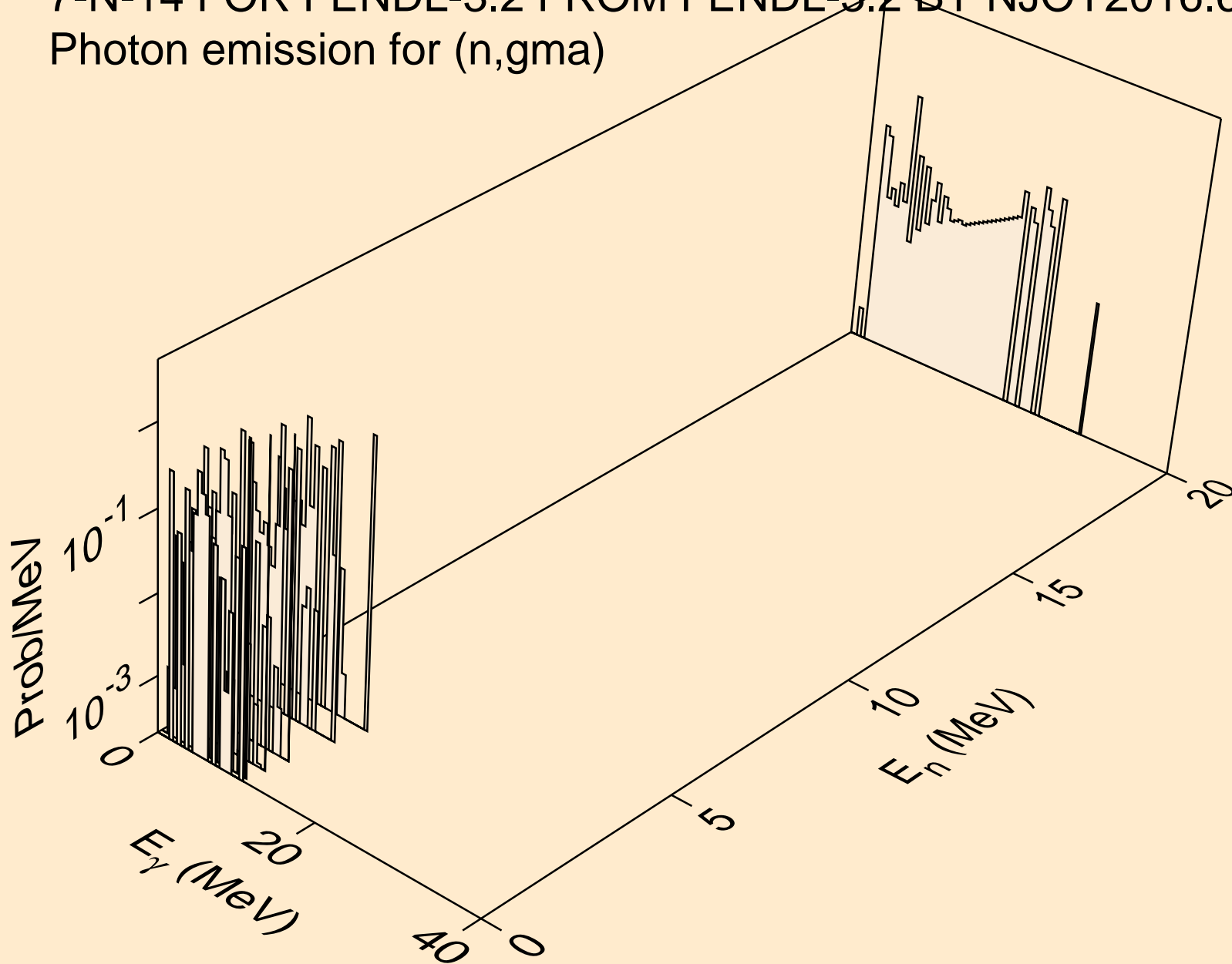

7-N-14 FOR FENDL-3.2 FROM FENDL-3.2 BY NJOY2016.60+ ON D
Photon emission for (n,p)

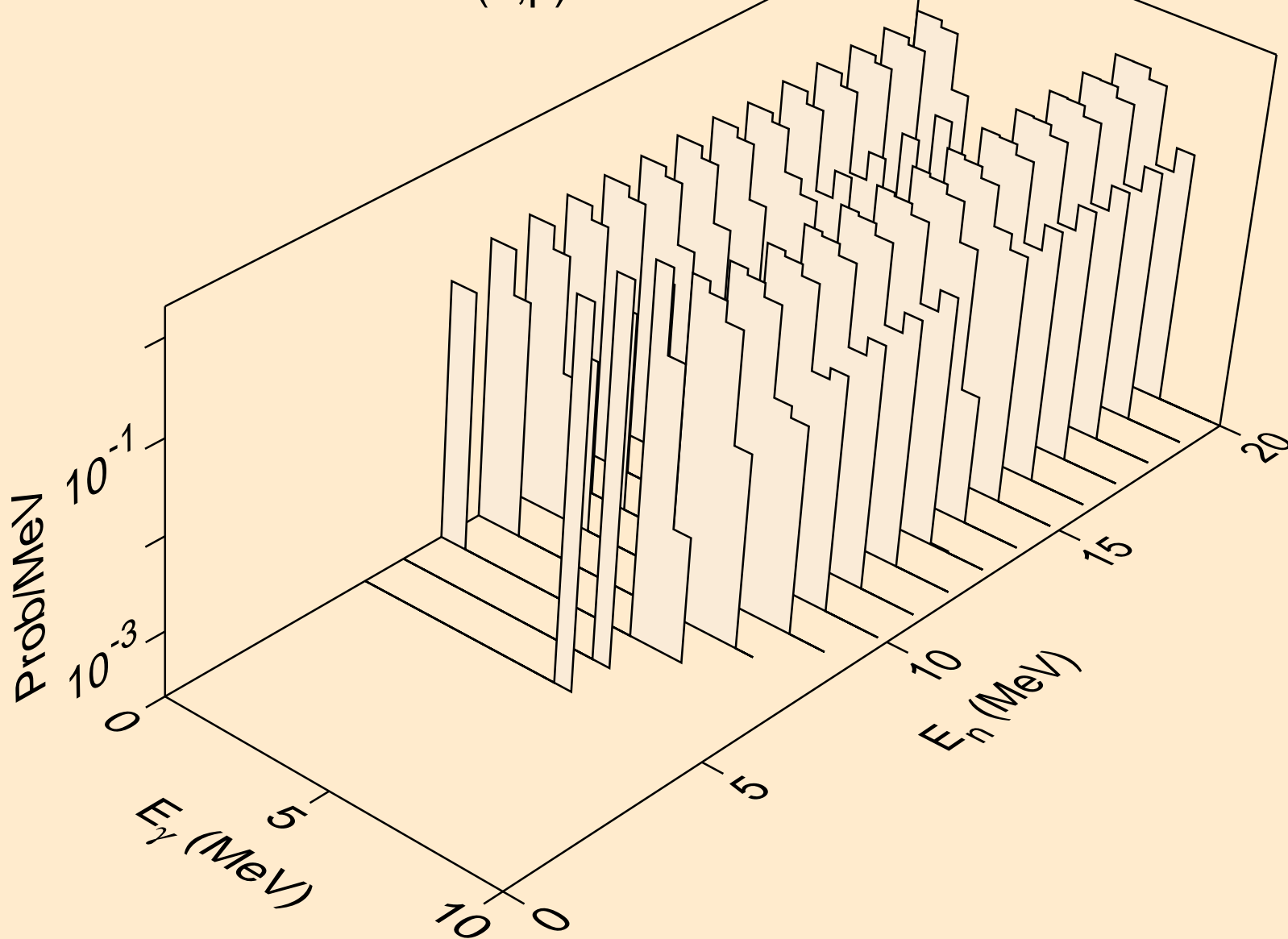

7-N-14 FOR FENDL-3.2 FROM FENDL-3.2 BY NJOY2016.60+ ON D
Photon emission for nonelastic

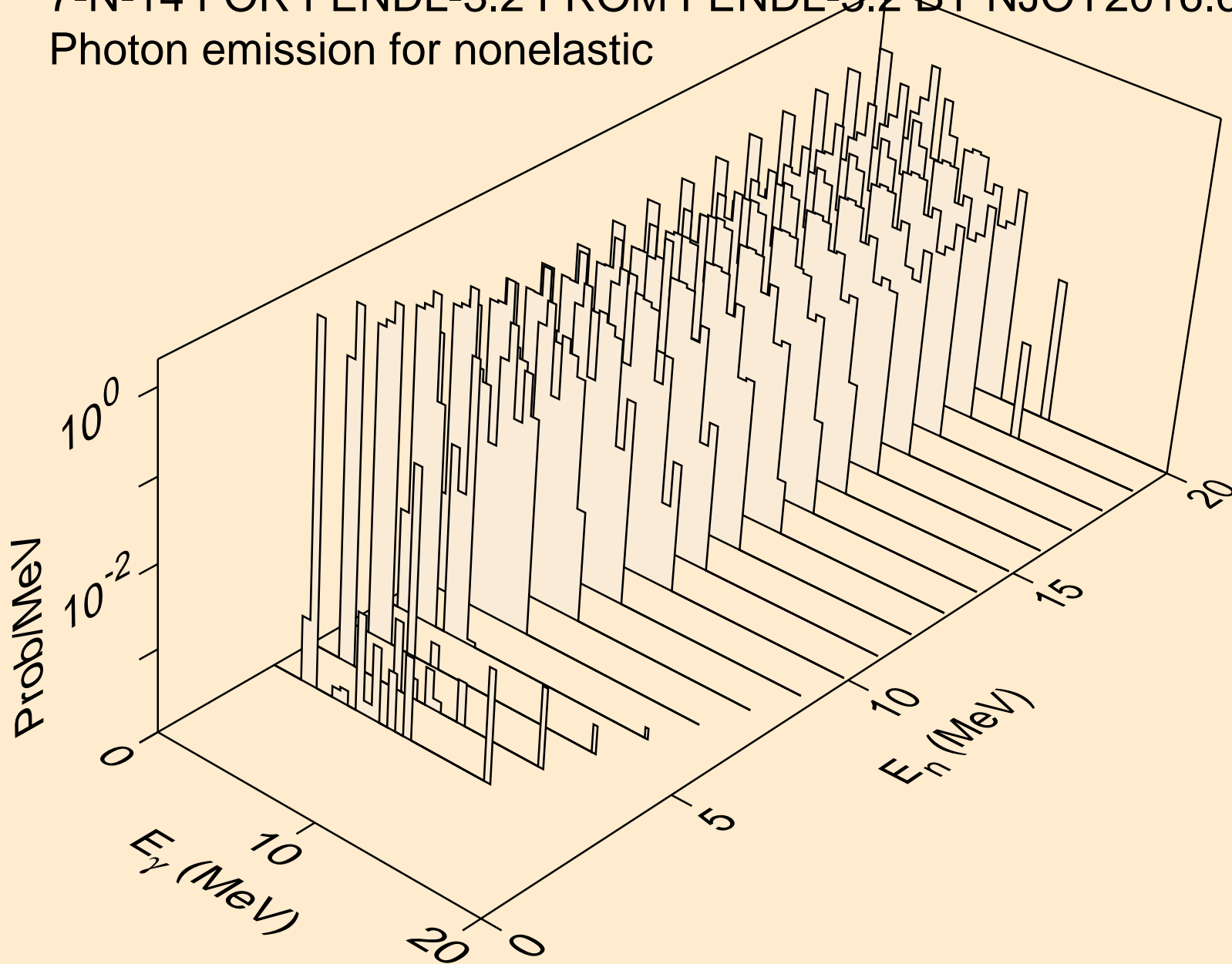

7-N-14 FOR FENDL-3.2 FROM FENDL-3.2 BY NJOY2016.60+ ON D
Photon emission for (n,x)

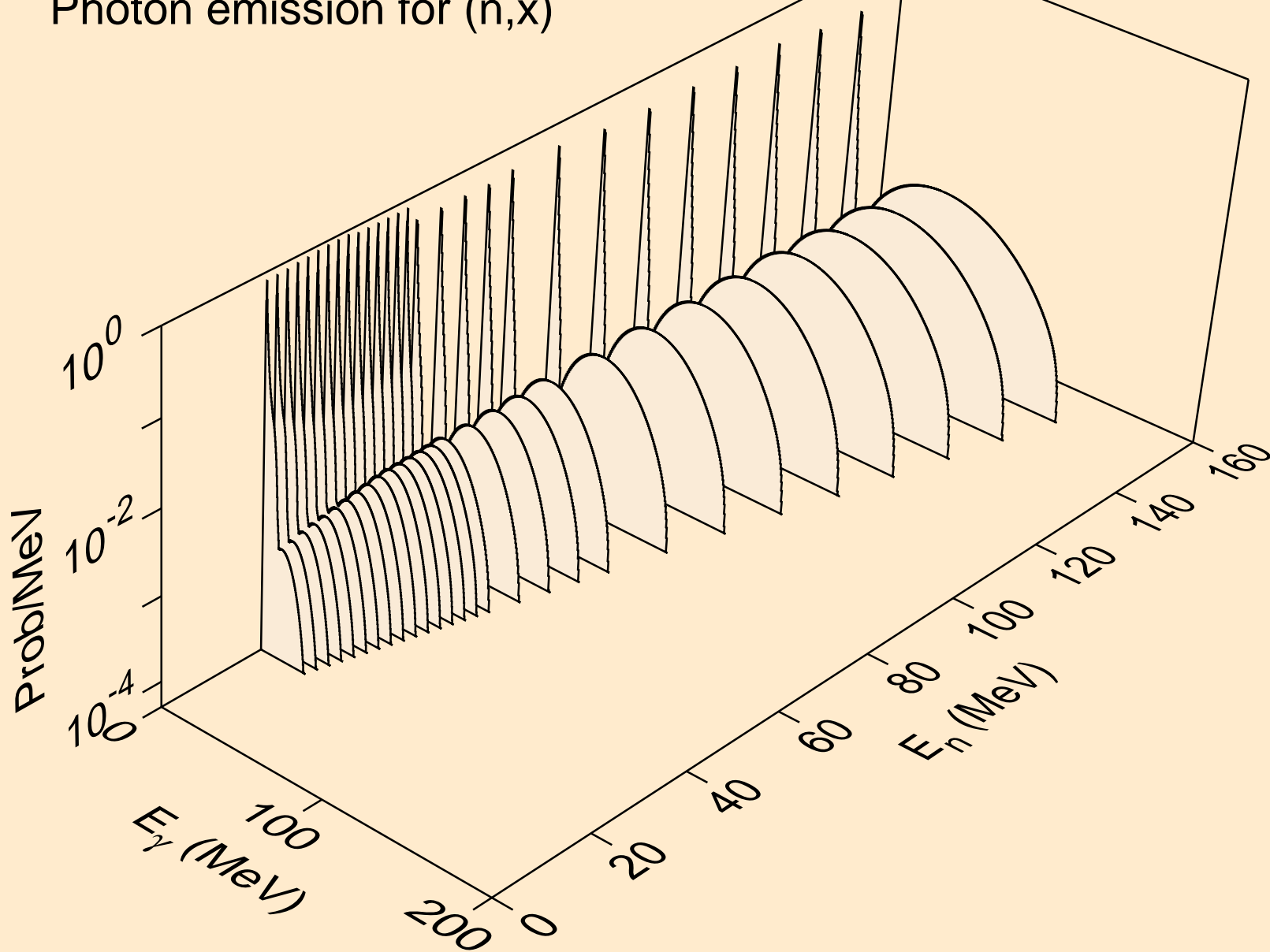

7-N-14 FOR FENDL-3.2 FROM FENDL-3.2 BY NJOY2016.60+ ON D
thermal capture photon spectrum

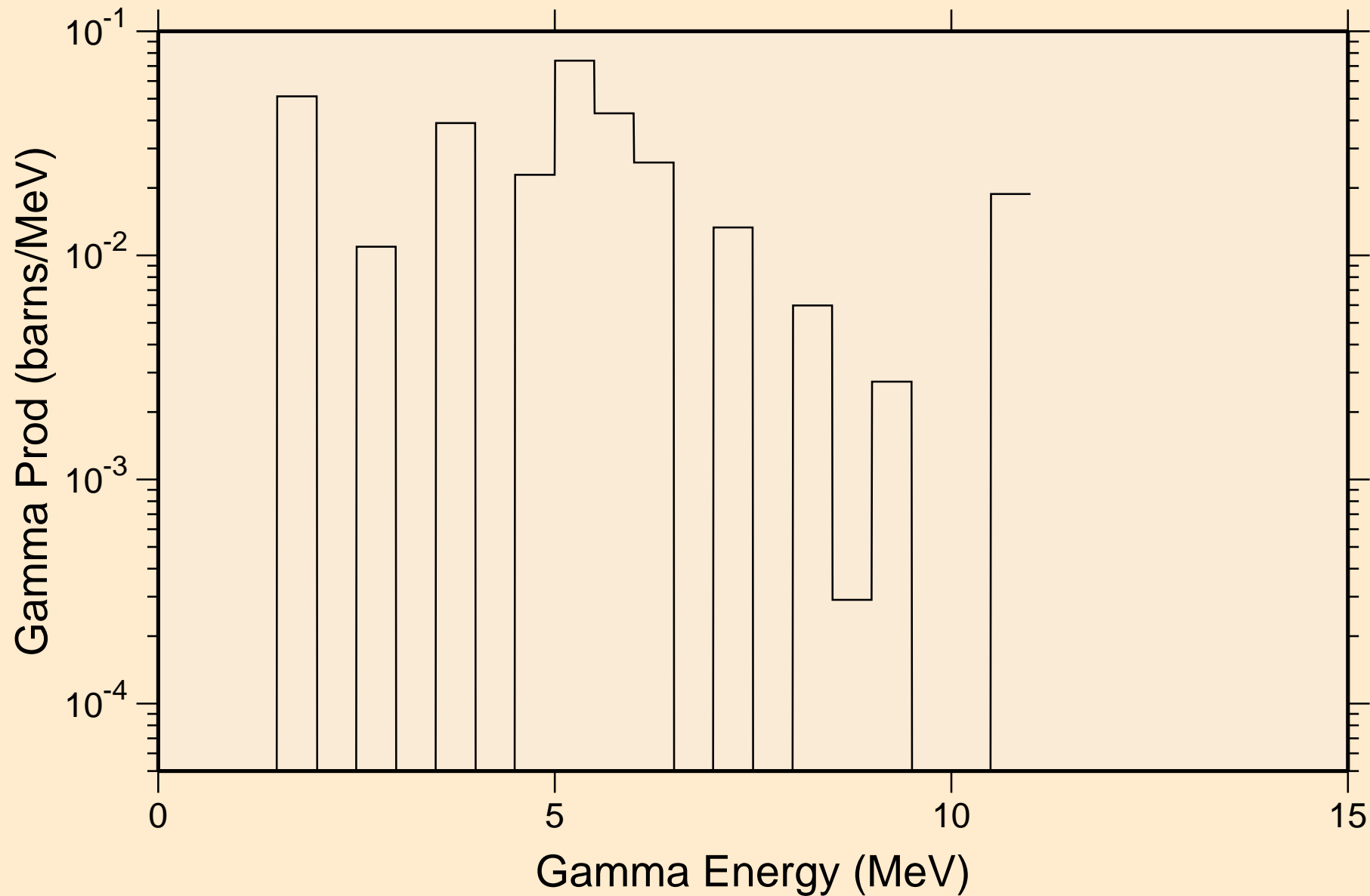

7-N-14 FOR FENDL-3.2 FROM FENDL-3.2 BY NJOY2016.60+ ON D
14 MeV photon spectrum

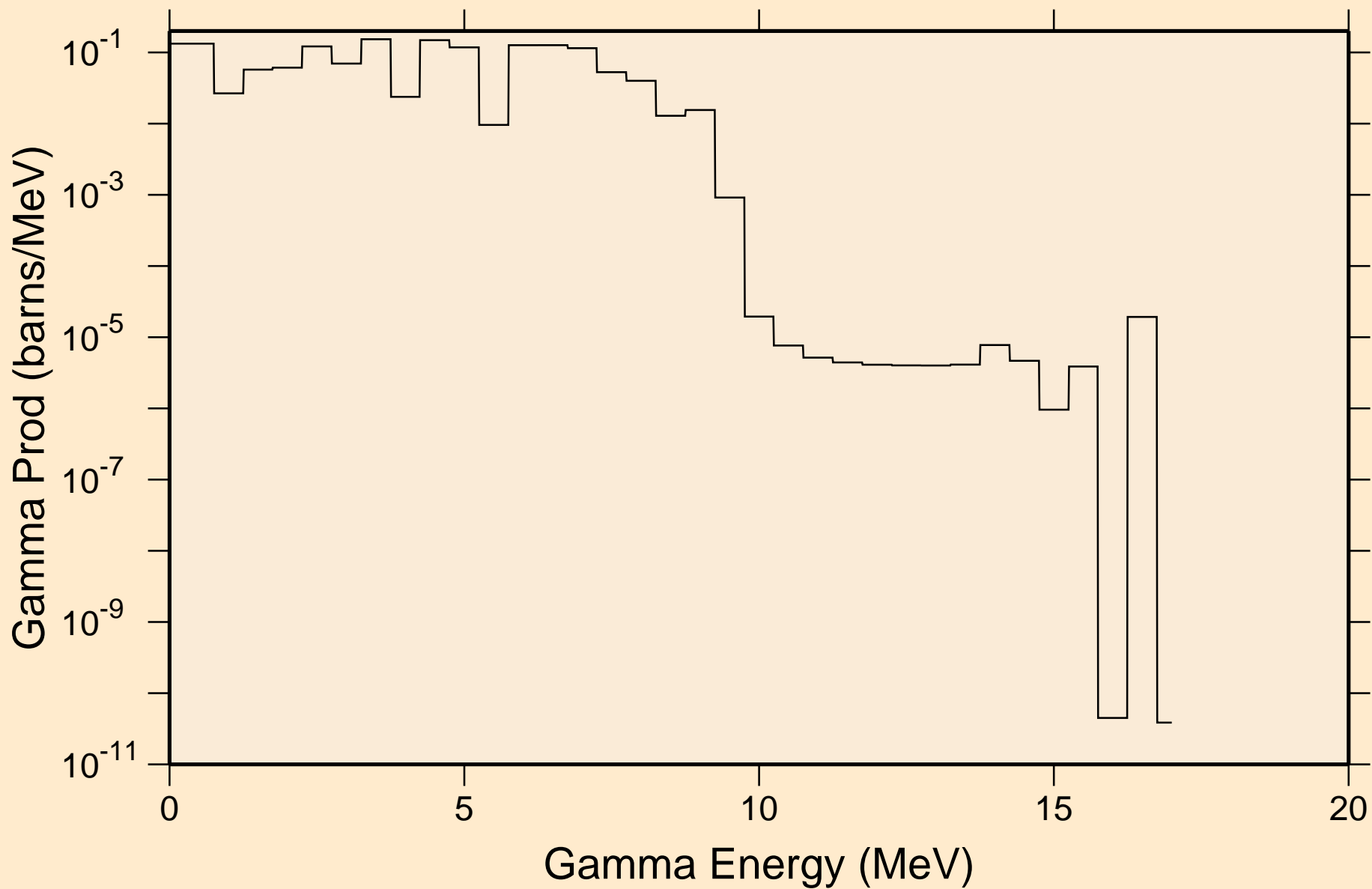

7-N-14 FOR FENDL-3.2 FROM FENDL-3.2 BY NJOY2016.60+ ON D

Particle heating contributions

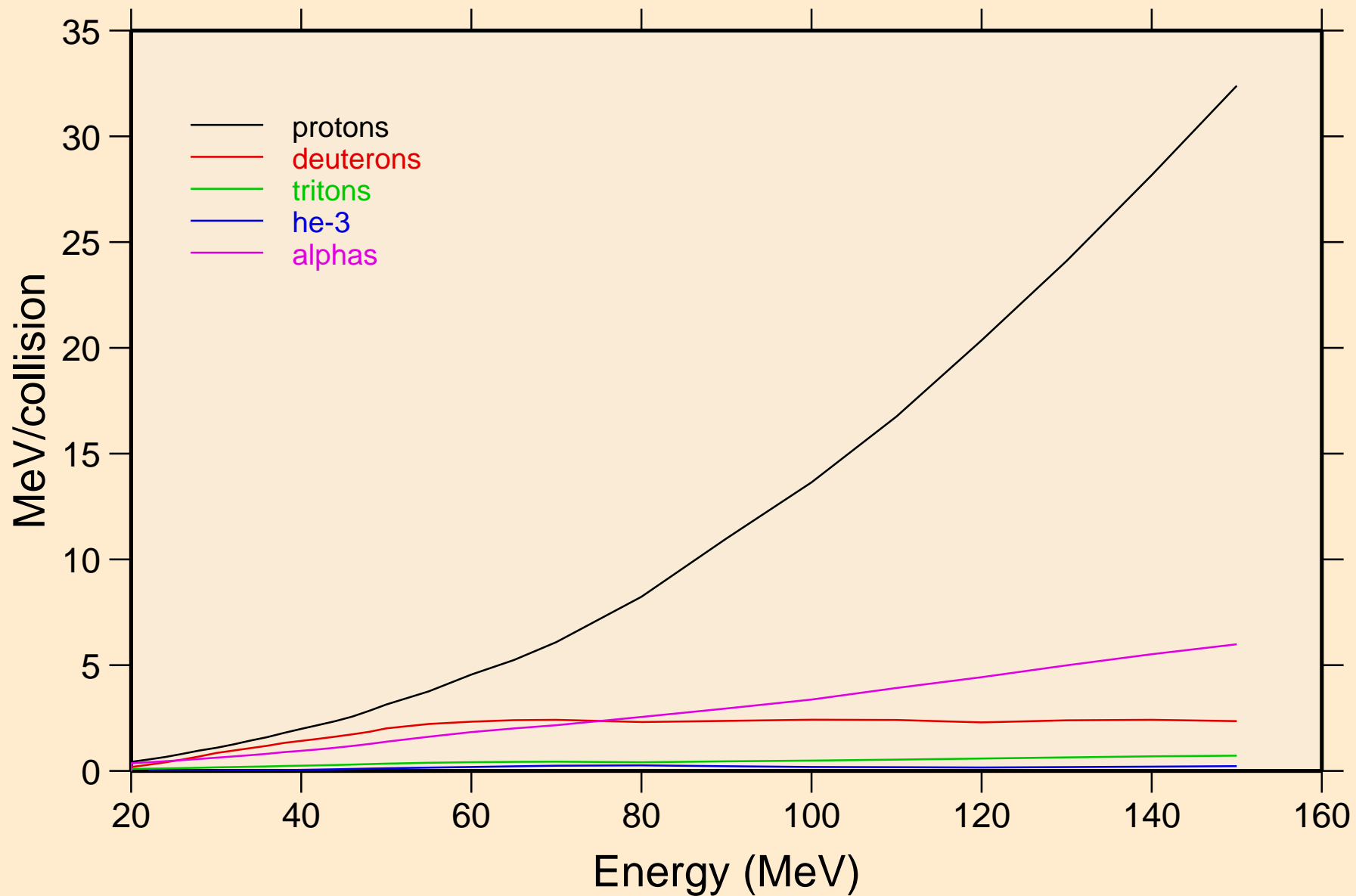

7-N-14 FOR FENDL-3.2 FROM FENDL-3.2 BY NJOY2016.60+ ON D Recoil Heating

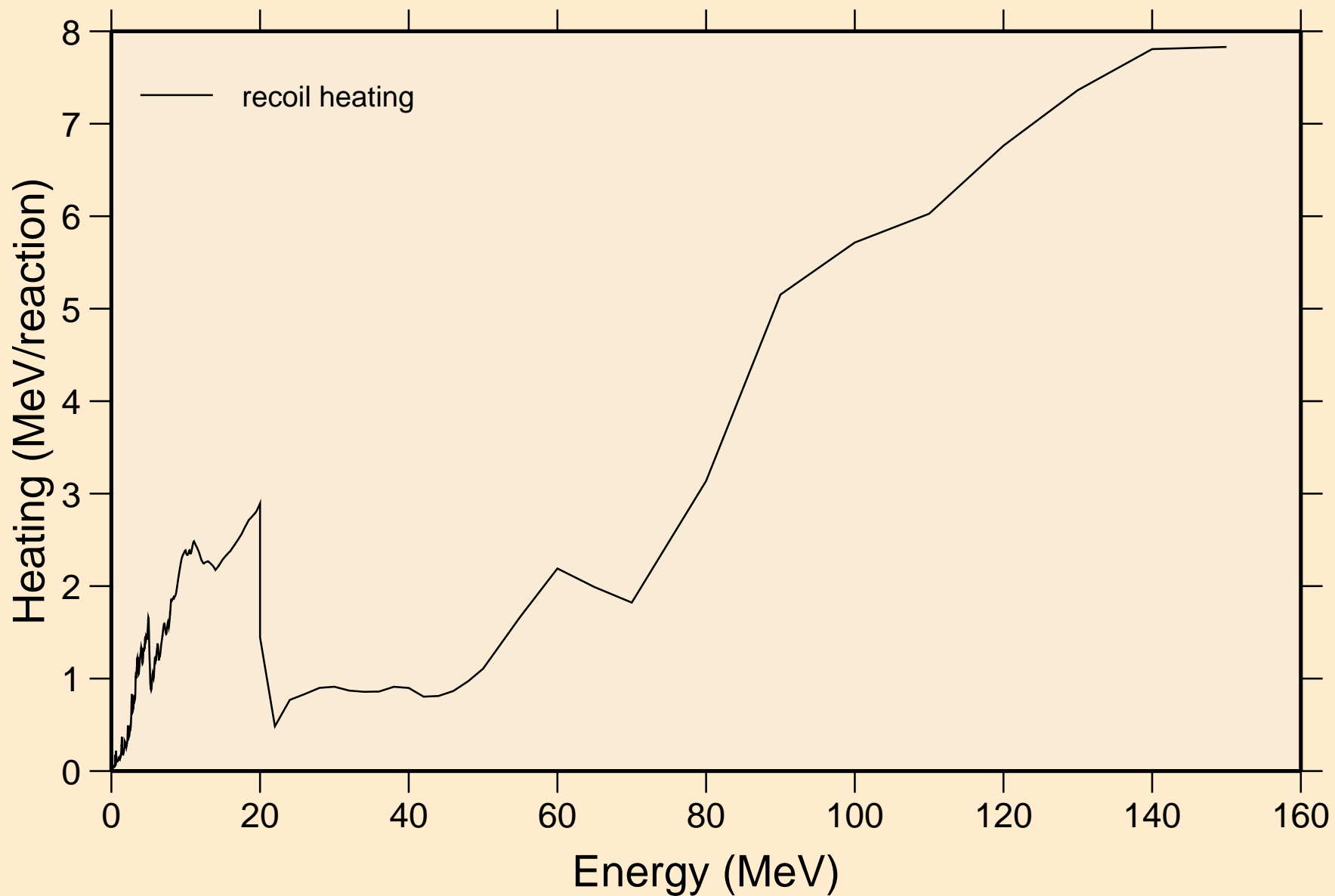

7-N-14 FOR FENDL-3.2 FROM FENDL-3.2 BY NJOY2016.60+ ON D

Particle production cross sections

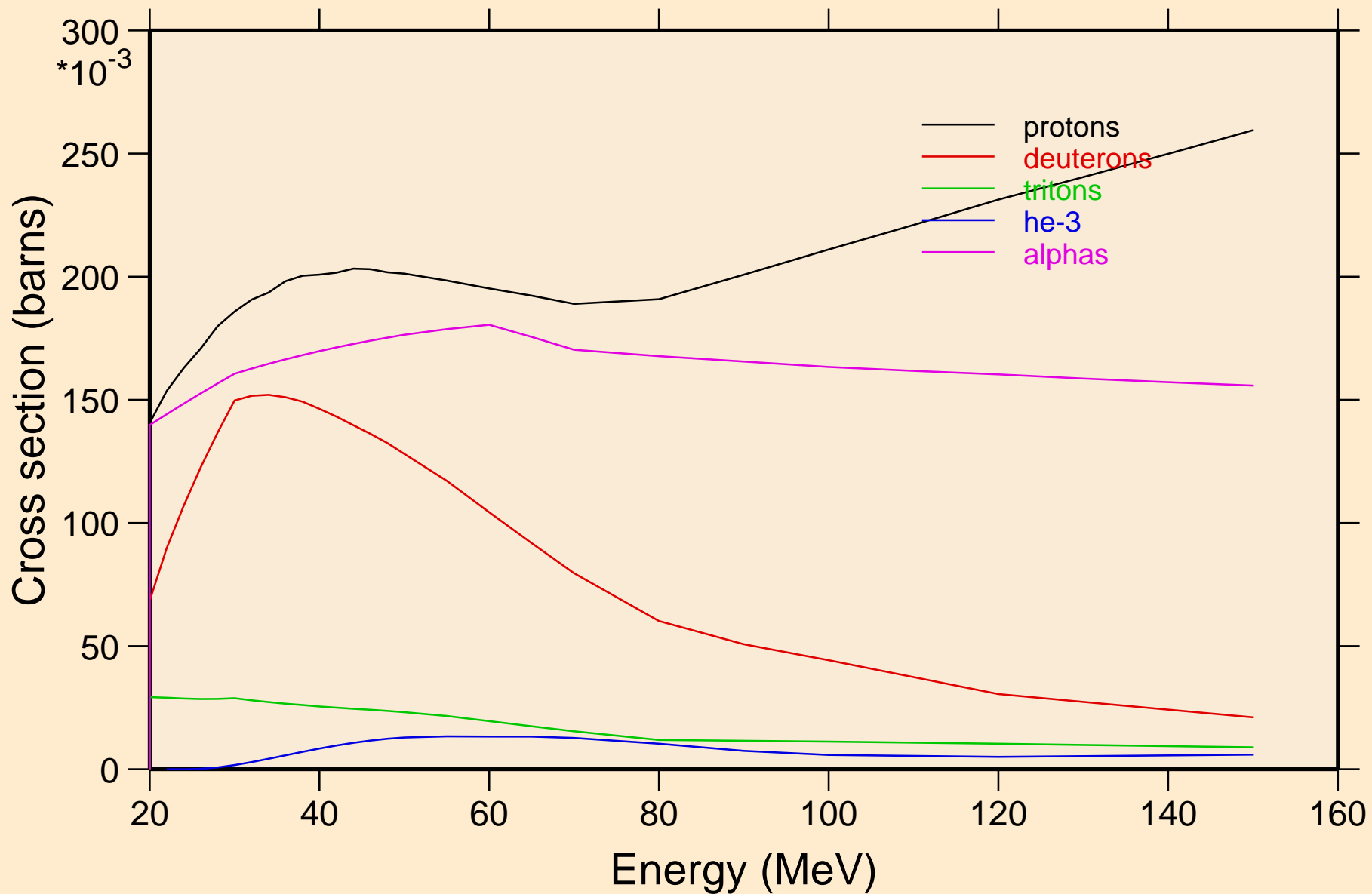

7-N-14 FOR FENDL-3.2 FROM FENDL-3.2 BY NJOY2016.60+ ON D
protons from (n,x)

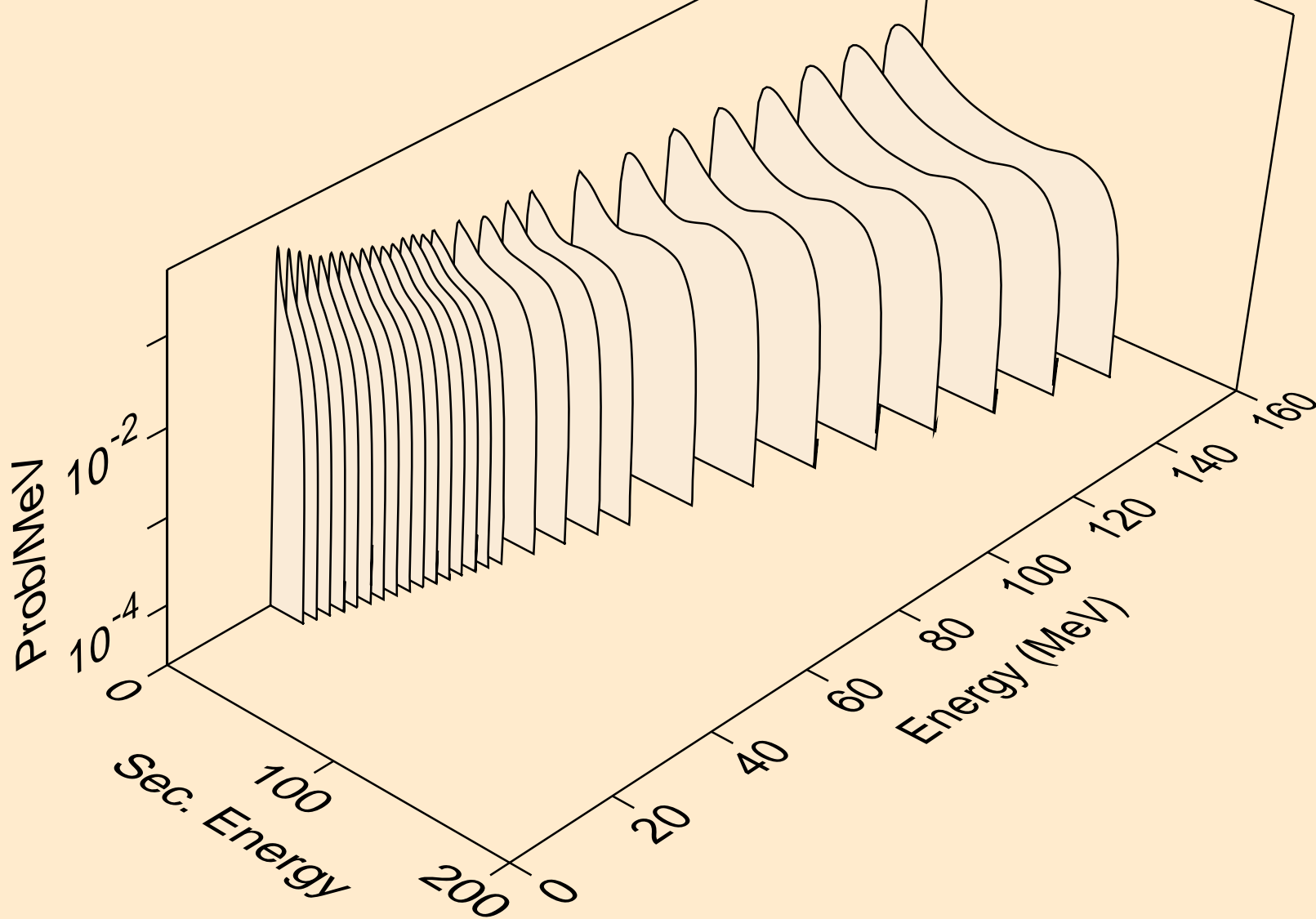

7-N-14 FOR FENDL-3.2 FROM FENDL-3.2 BY NJOY2016.60+ ON D
deuterons from (n,x)

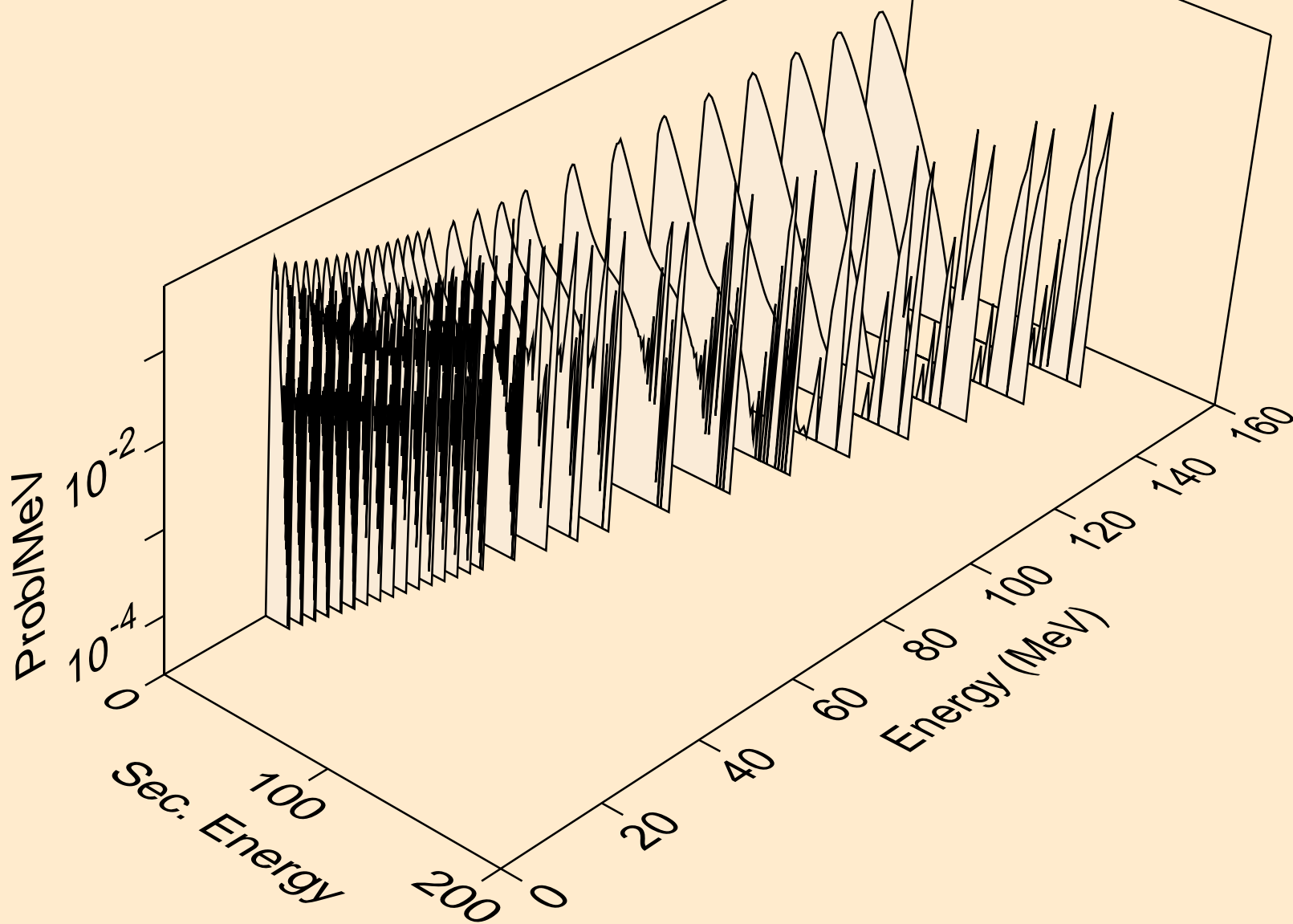

7-N-14 FOR FENDL-3.2 FROM FENDL-3.2 BY NJOY2016.60+ ON D
tritons from (n,x)

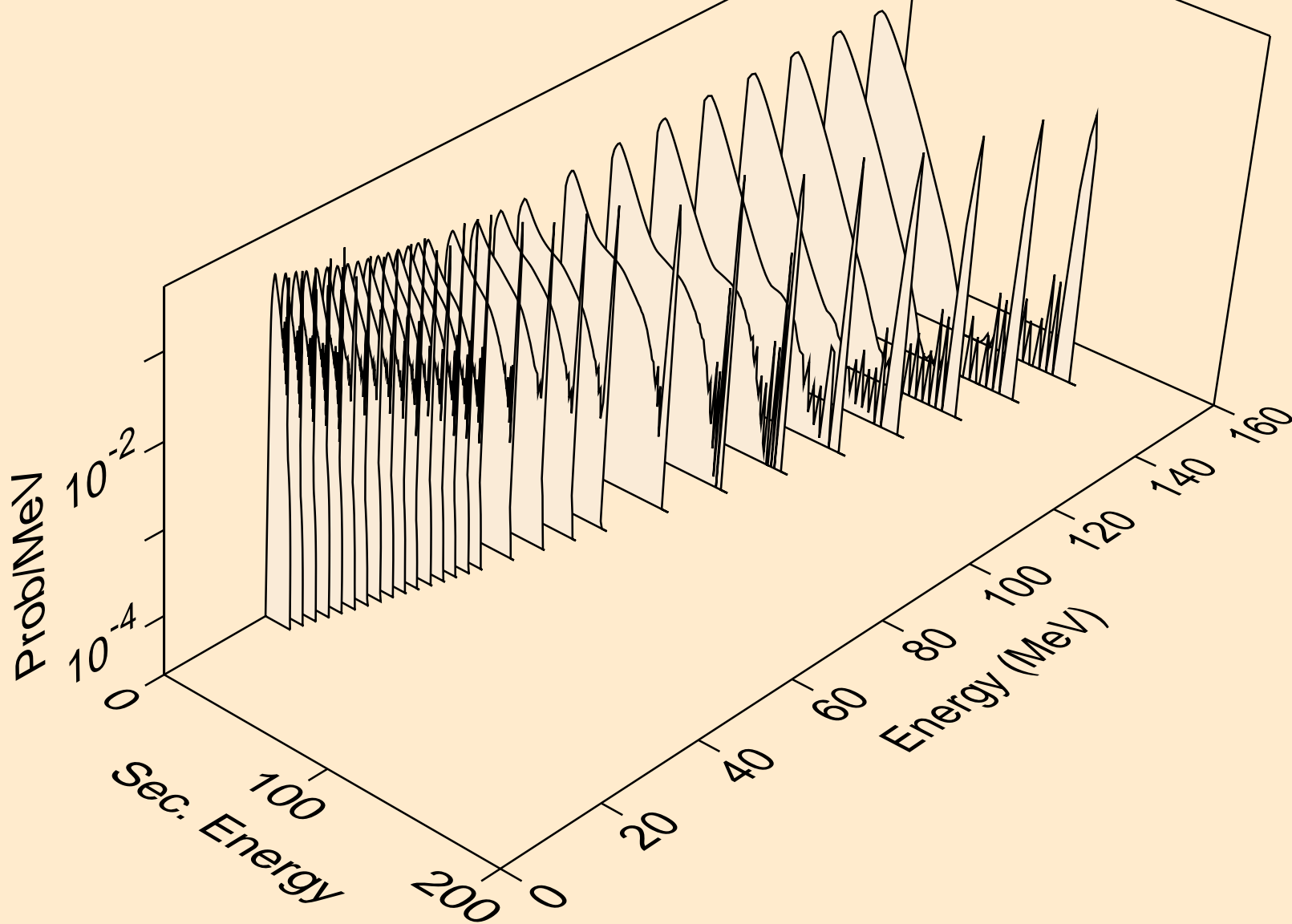

7-N-14 FOR FENDL-3.2 FROM FENDL-3.2 BY NJOY2016.60+ ON D
he3s from (n,x)

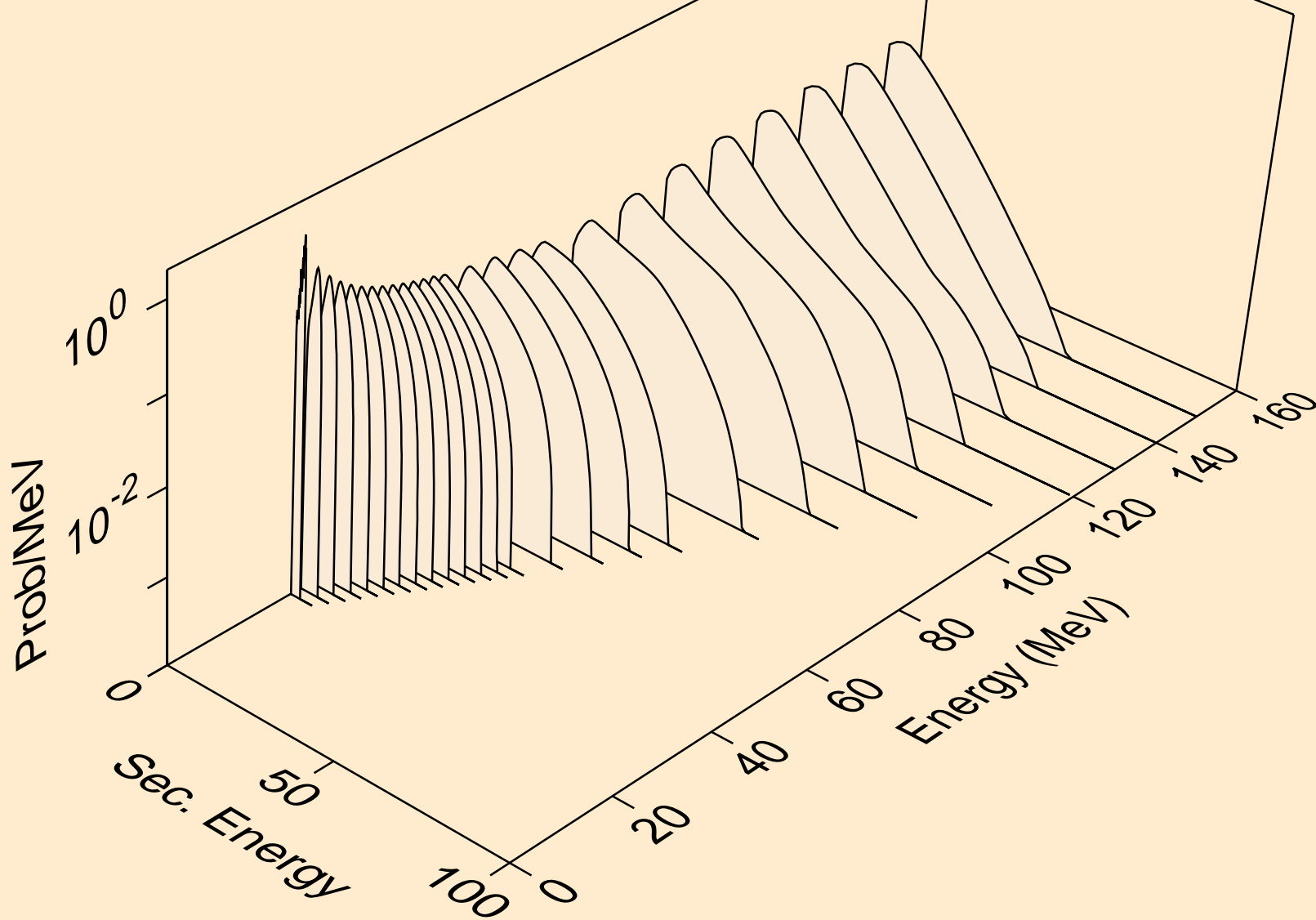

7-N-14 FOR FENDL-3.2 FROM FENDL-3.2 BY NJOY2016.60+ ON D
alphas from (n,x)

