

24-CR-54 FOR FENDL-3.2 FROM INDEN-1.0 BY NJOY2016.60+ OI
Principal cross sections

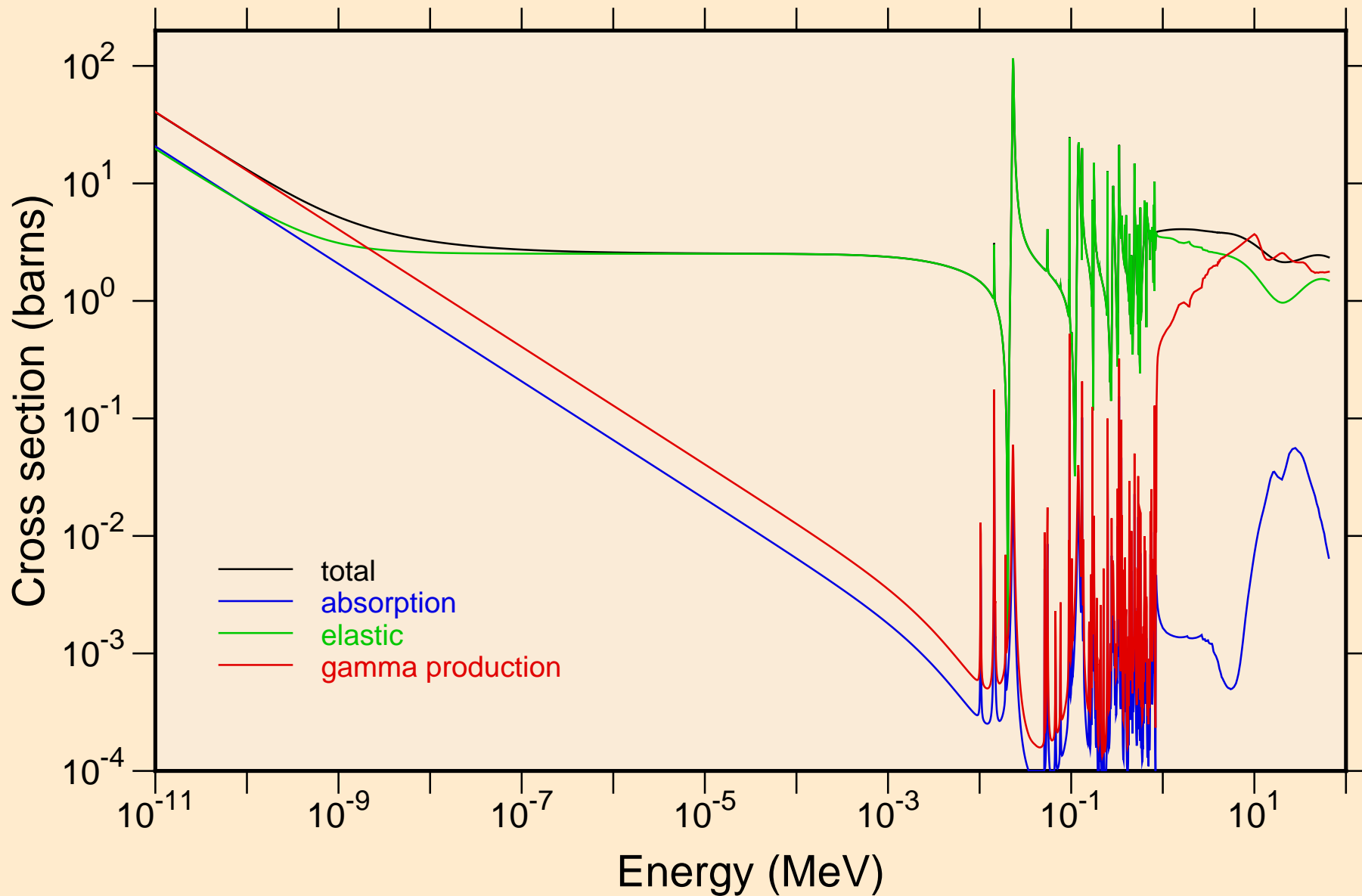

24-CR-54 FOR FENDL-3.2 FROM INDEN-1.0 BY NJOY2016.60+ OI
resonance total cross section

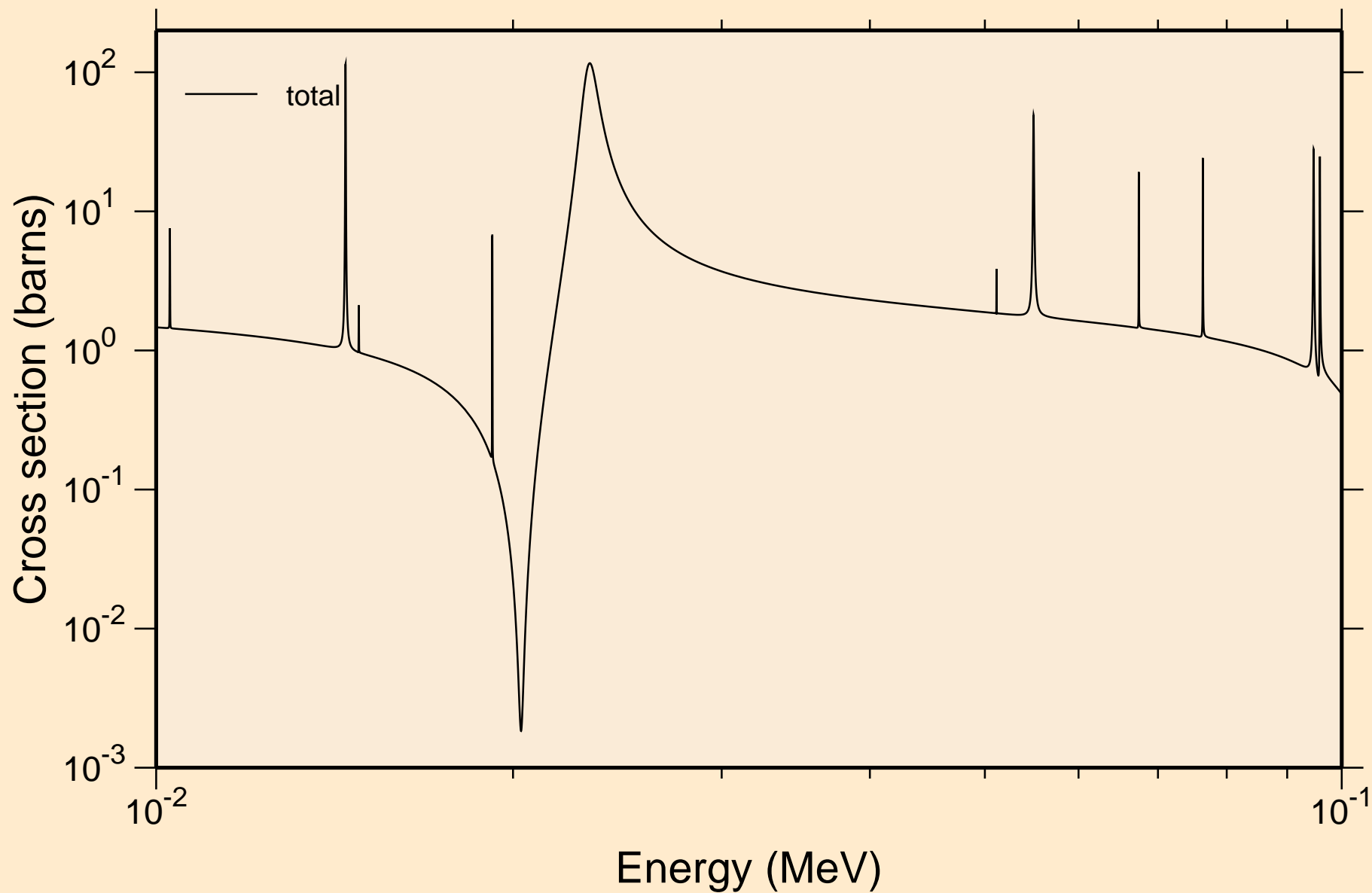

24-CR-54 FOR FENDL-3.2 FROM INDEN-1.0 BY NJOY2016.60+ OI
resonance total cross section

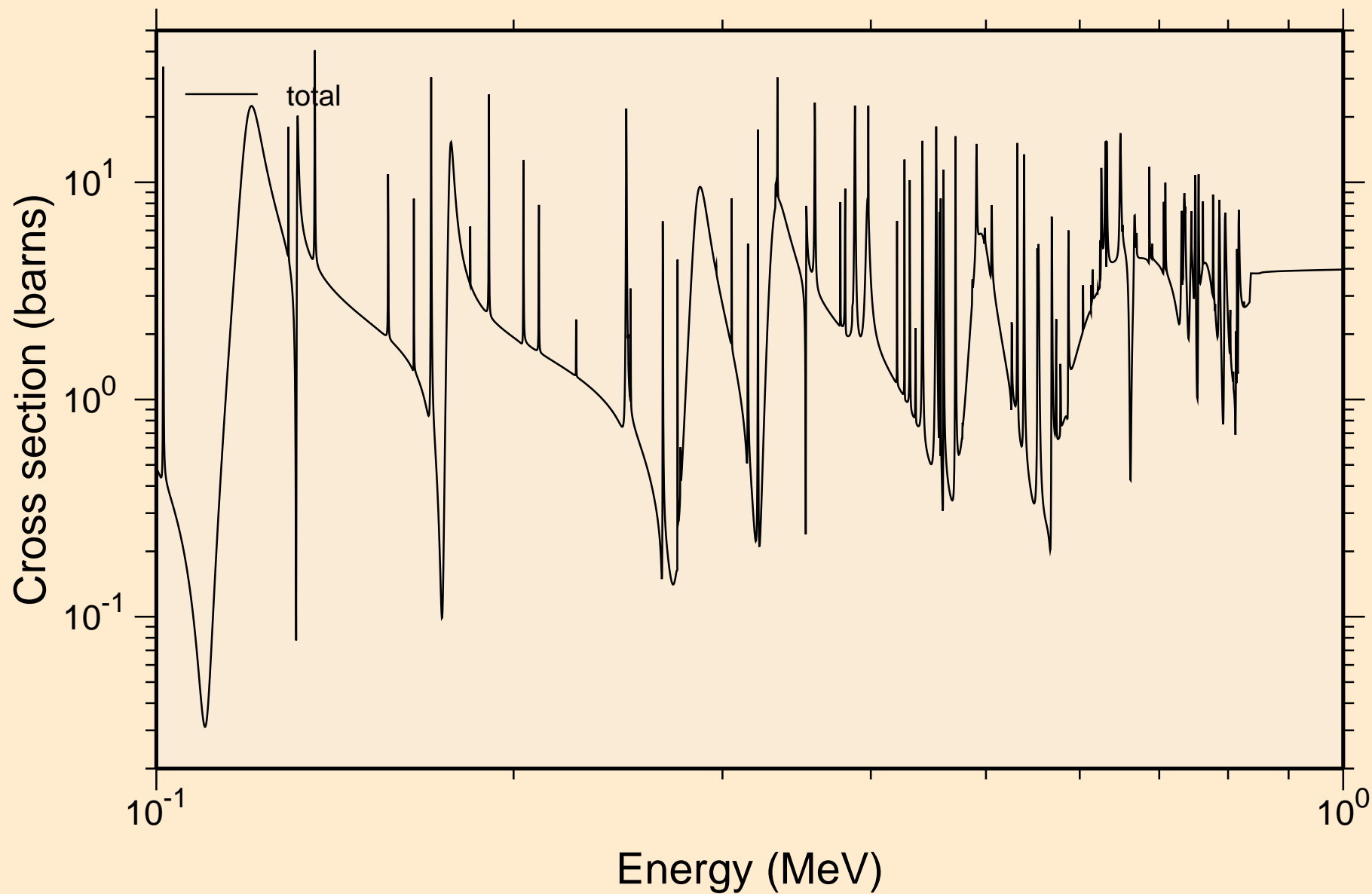

24-CR-54 FOR FENDL-3.2 FROM INDEN-1.0 BY NJOY2016.60+ OI
resonance absorption cross sections

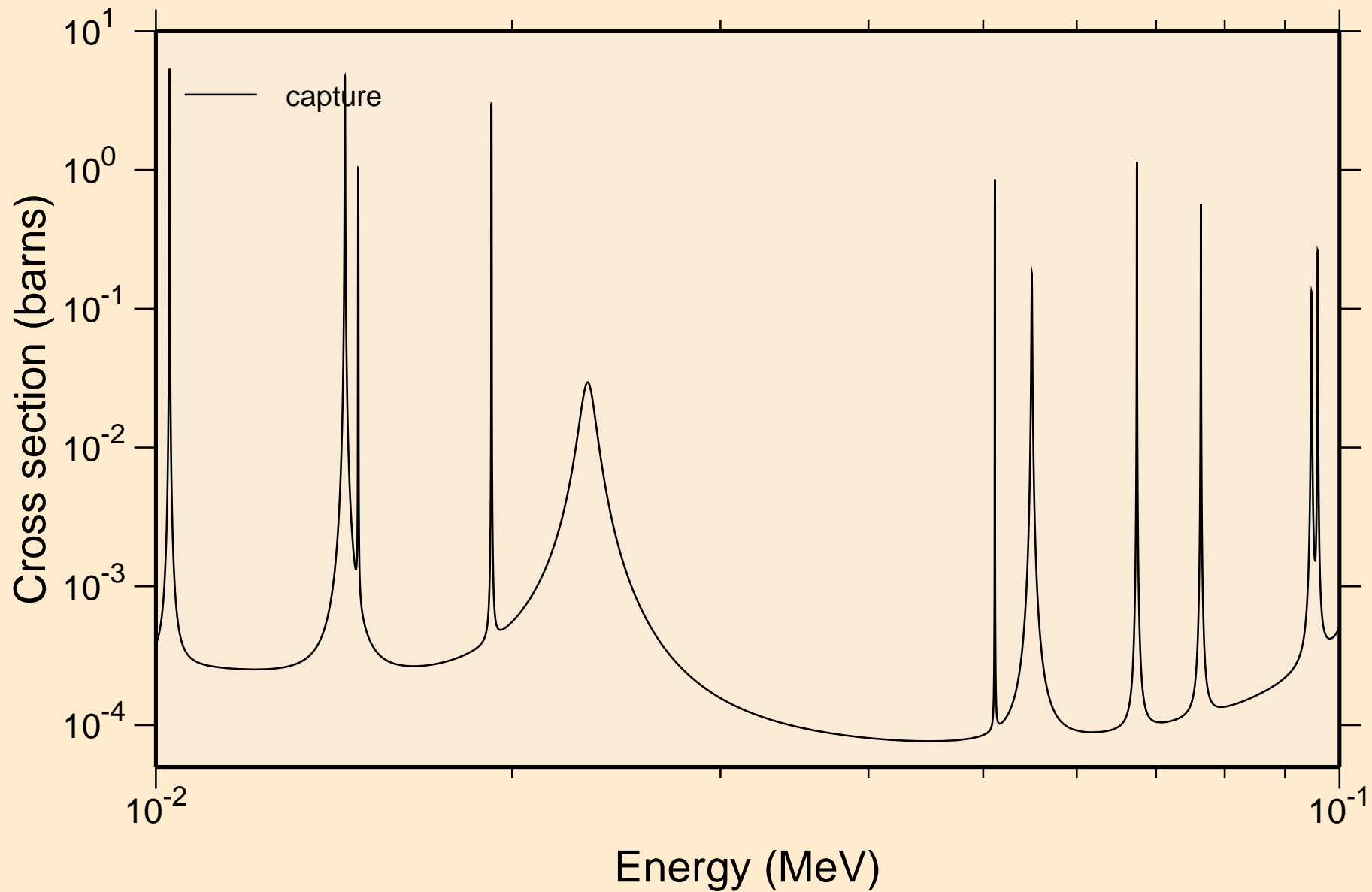

24-CR-54 FOR FENDL-3.2 FROM INDEN-1.0 BY NJOY2016.60+ OI
resonance absorption cross sections

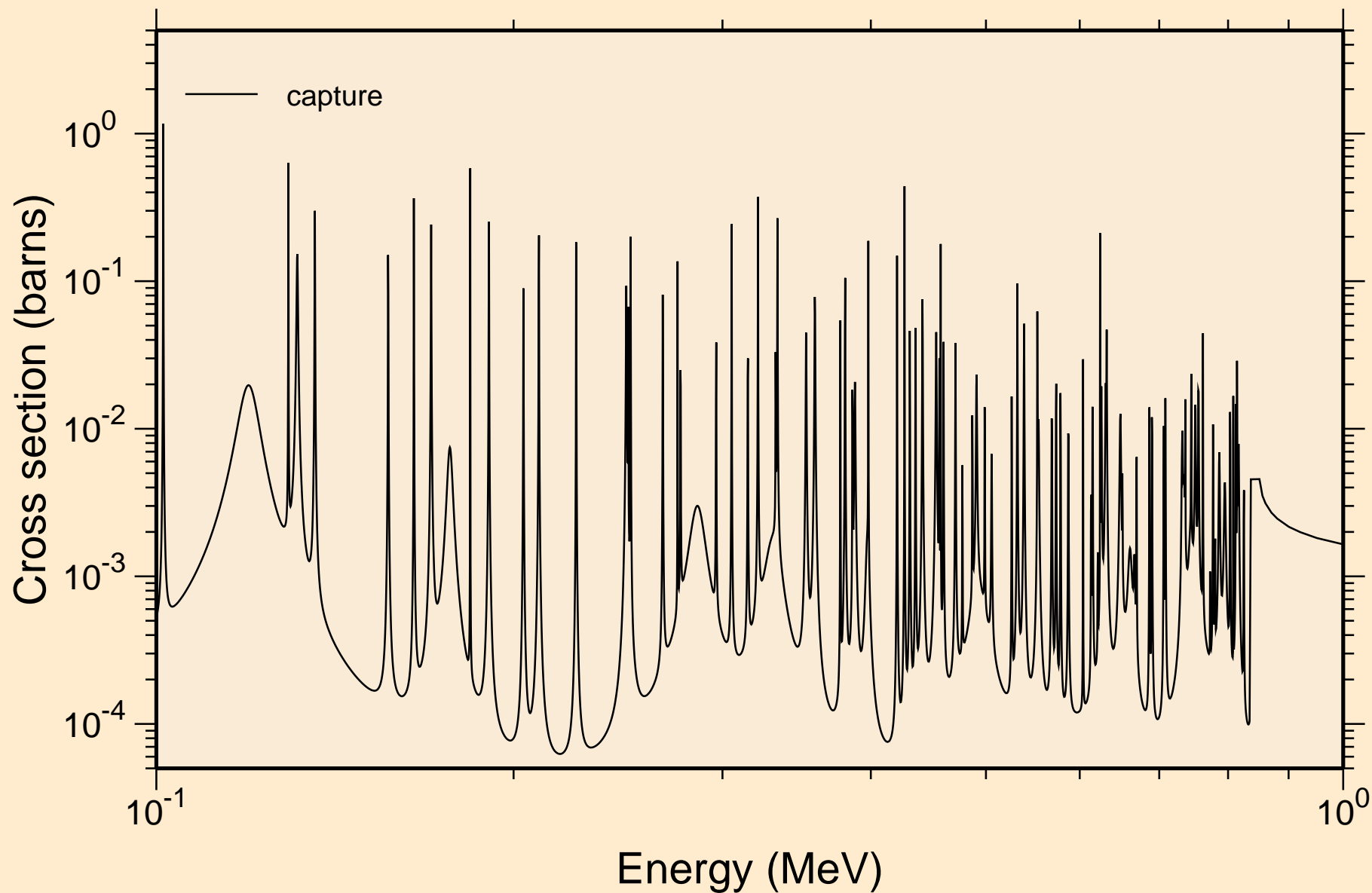

24-CR-54 FOR FENDL-3.2 FROM INDEN-1.0 BY NJOY2016.60+ OI Heating

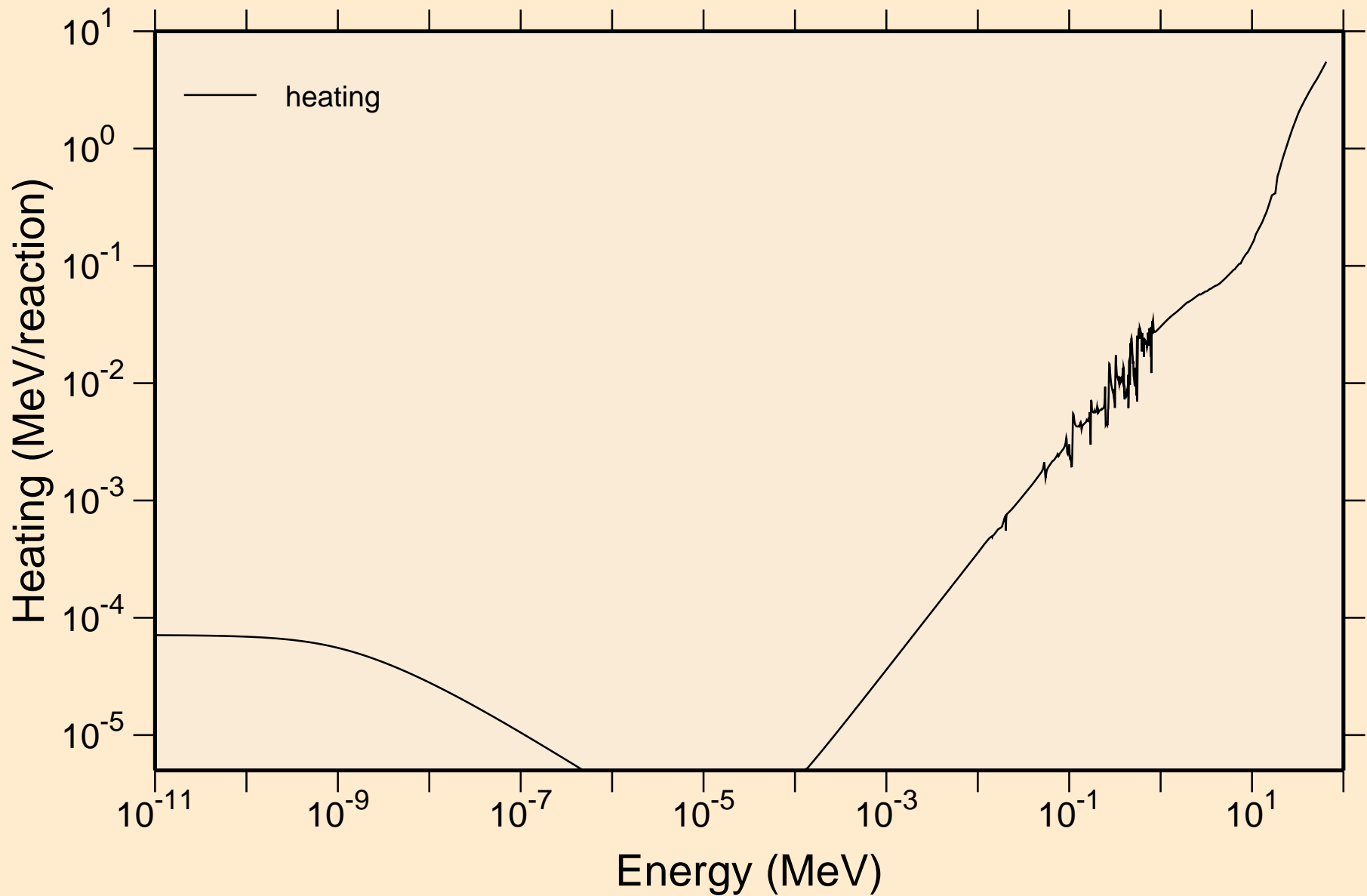

24-CR-54 FOR FENDL-3.2 FROM INDEN-1.0 BY NJOY2016.60+ OI Damage

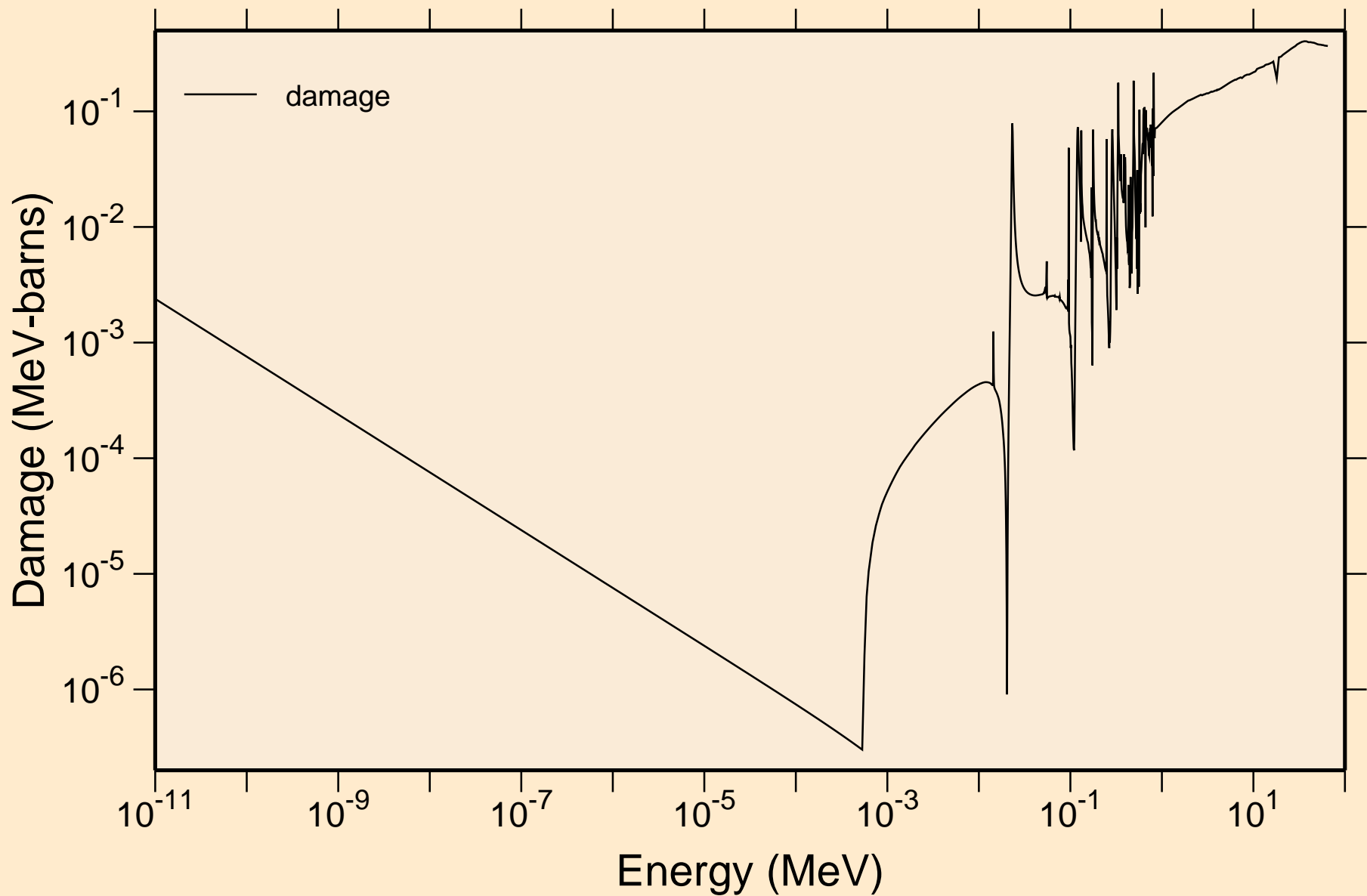

24-CR-54 FOR FENDL-3.2 FROM INDEN-1.0 BY NJOY2016.60+ OI
Non-threshold reactions

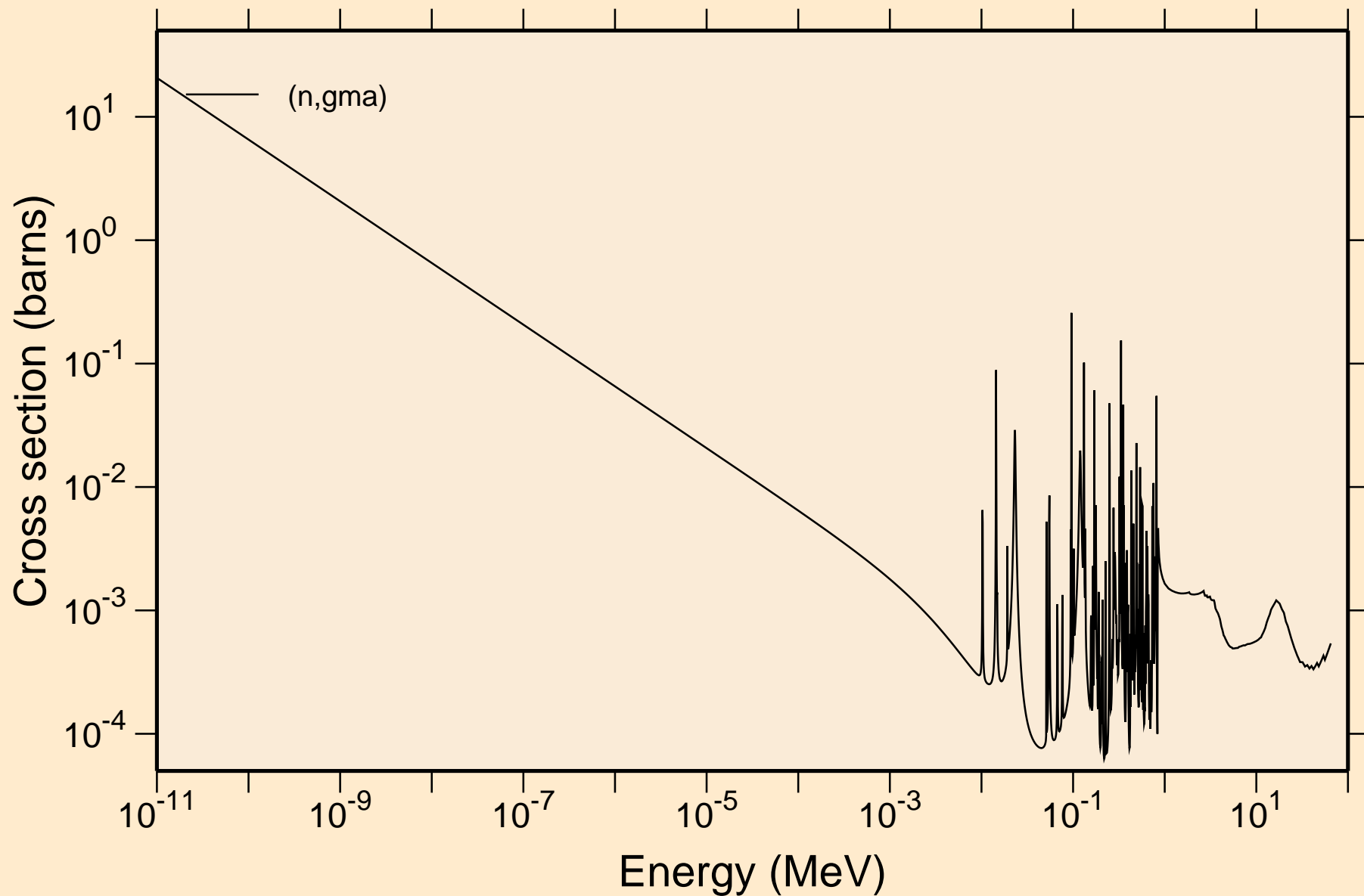

24-CR-54 FOR FENDL-3.2 FROM INDEN-1.0 BY NJOY2016.60+ OI

Principal cross sections

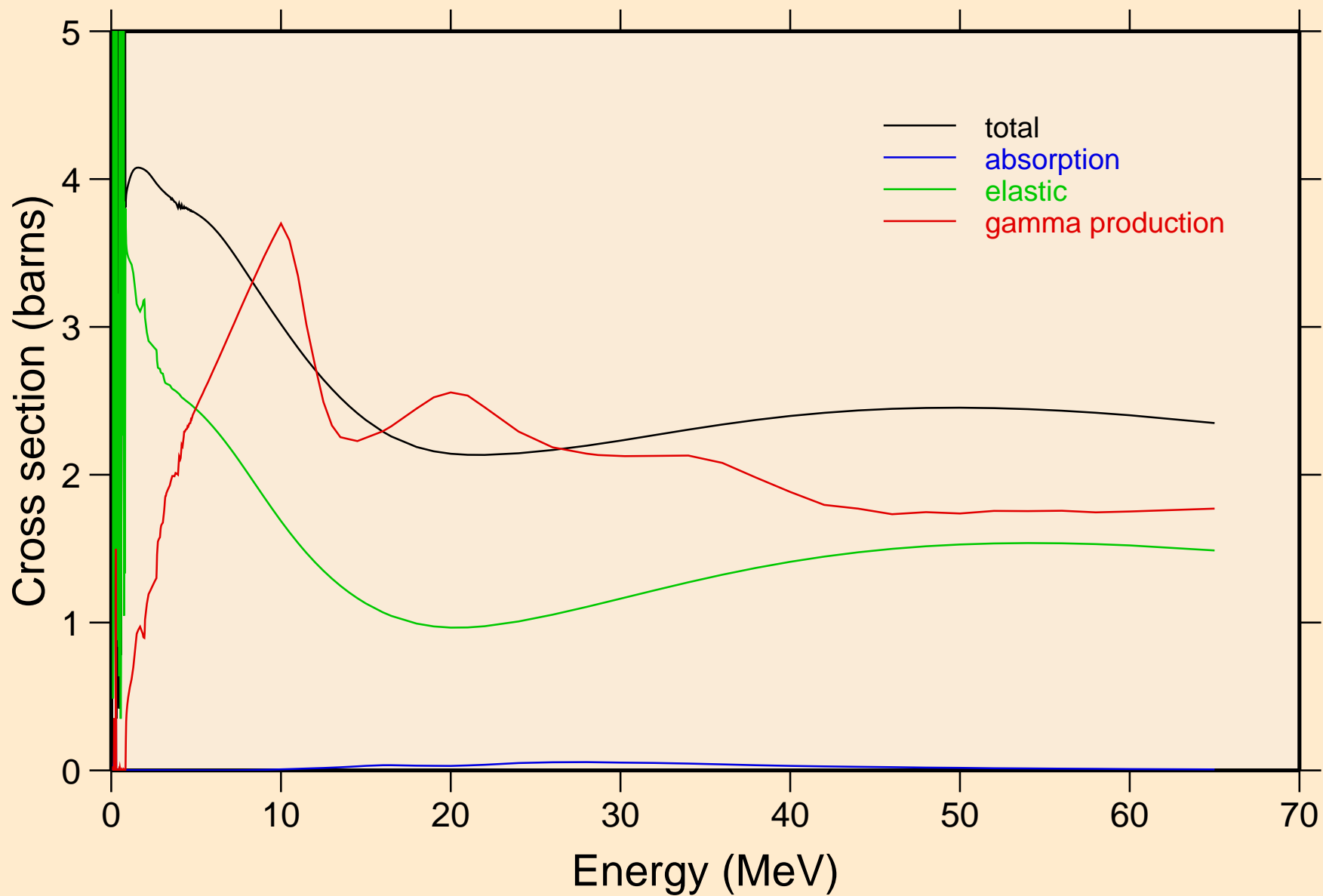

24-CR-54 FOR FENDL-3.2 FROM INDEN-1.0 BY NJOY2016.60+ OI Heating

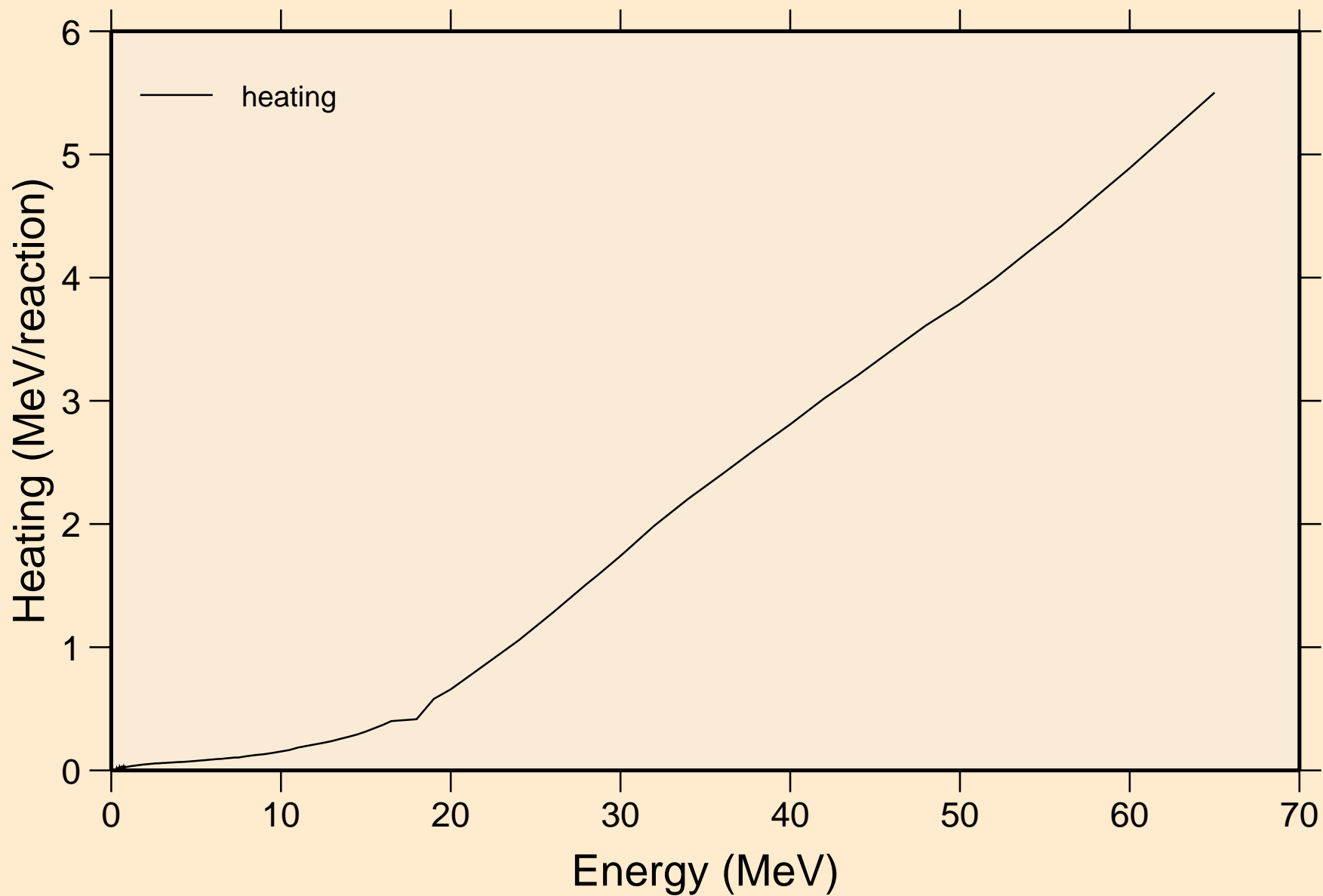

24-CR-54 FOR FENDL-3.2 FROM INDEN-1.0 BY NJOY2016.60+ OI Damage

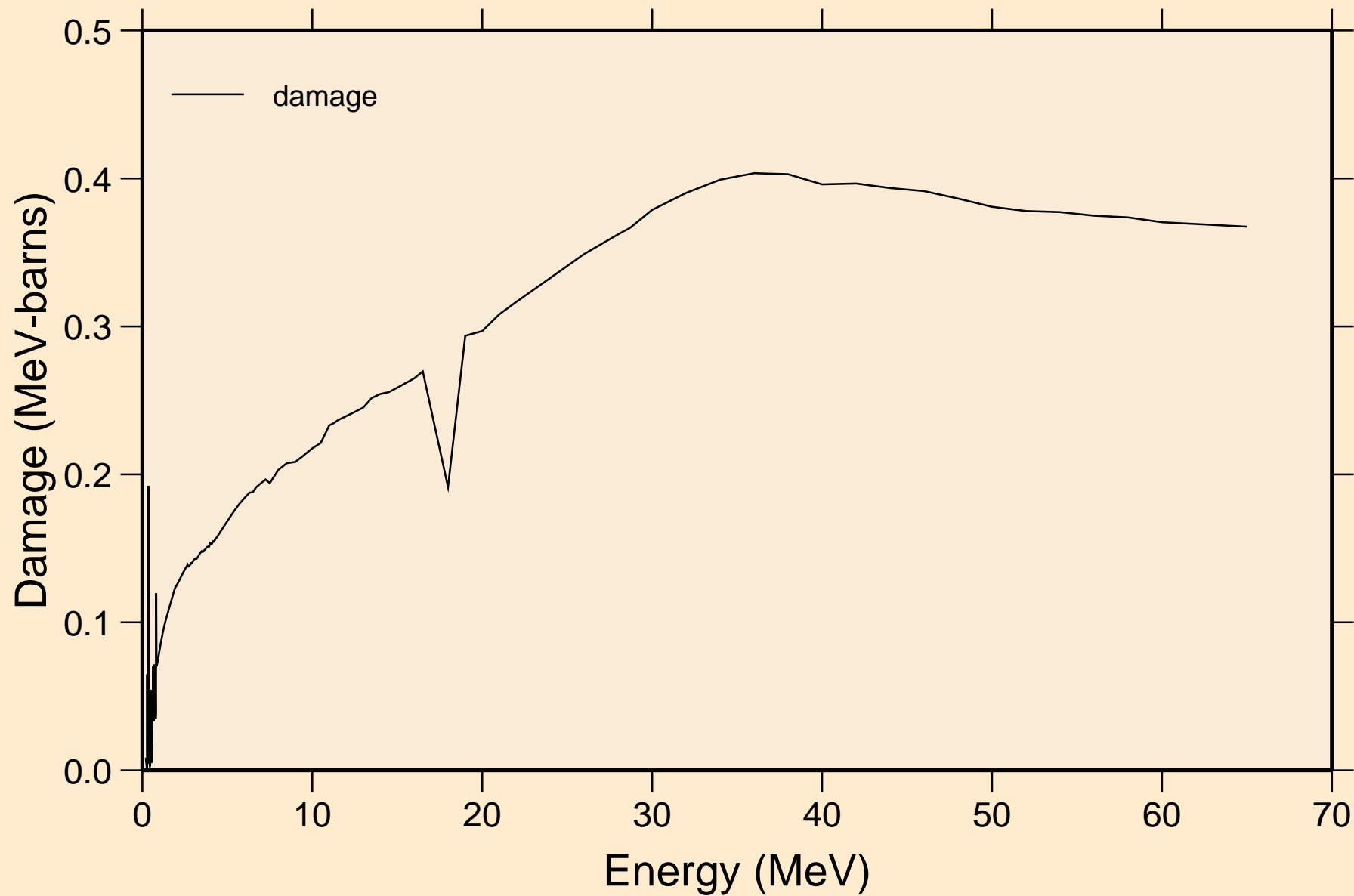

24-CR-54 FOR FENDL-3.2 FROM INDEN-1.0 BY NJOY2016.60+ OI
Non-threshold reactions

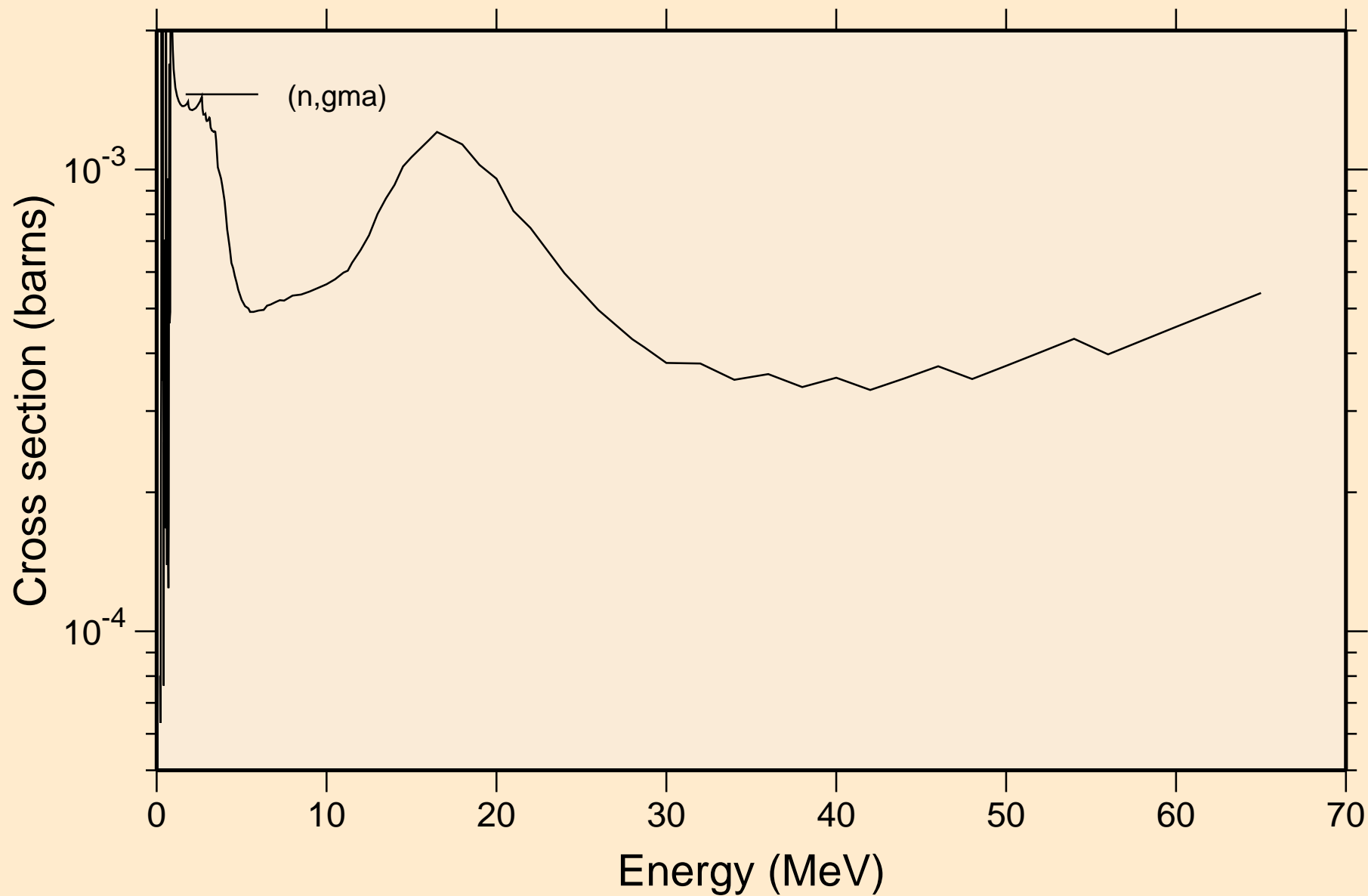

24-CR-54 FOR FENDL-3.2 FROM INDEN-1.0 BY NJOY2016.60+ OI Inelastic levels

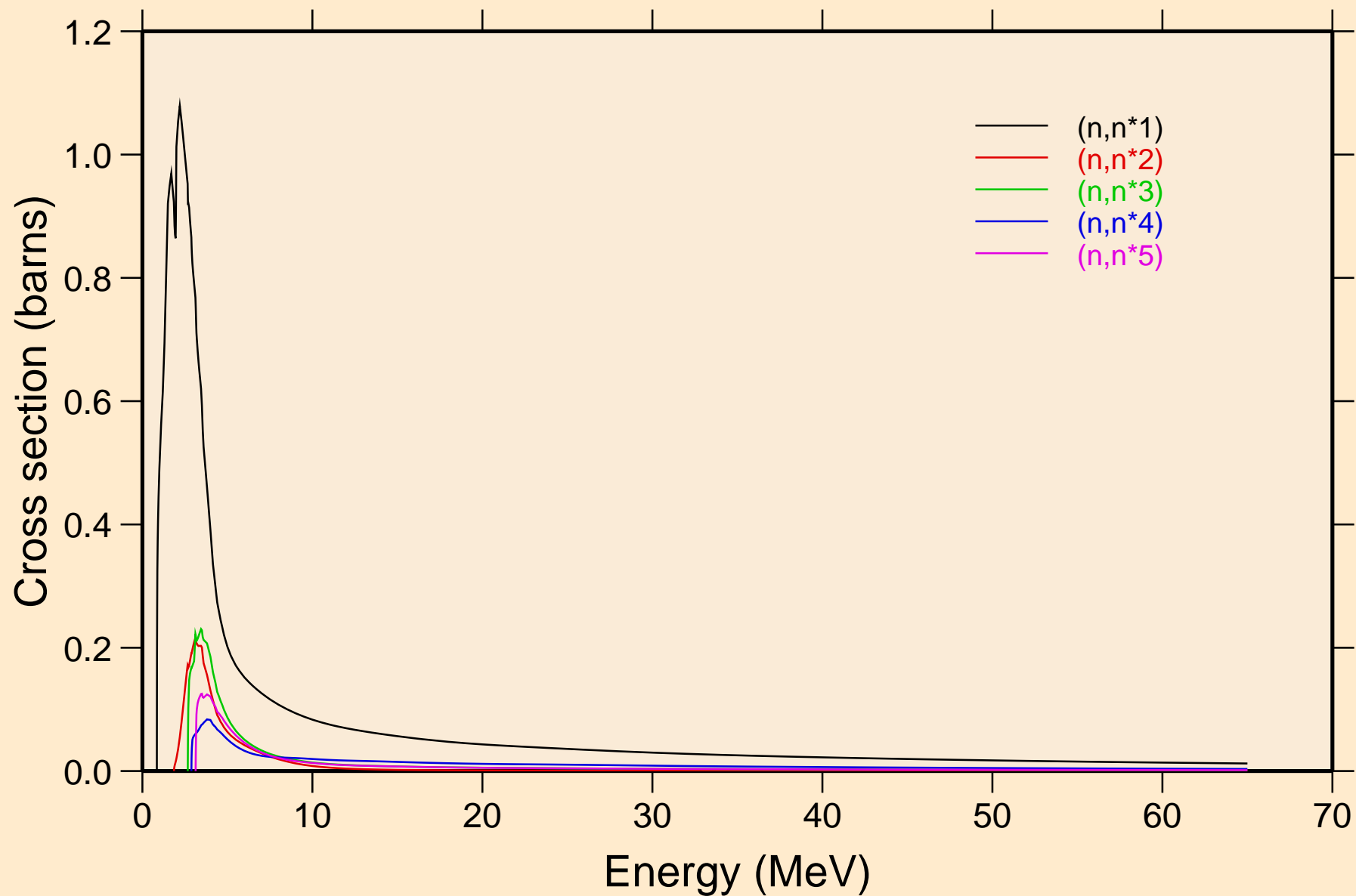

24-CR-54 FOR FENDL-3.2 FROM INDEN-1.0 BY NJOY2016.60+ OI Inelastic levels

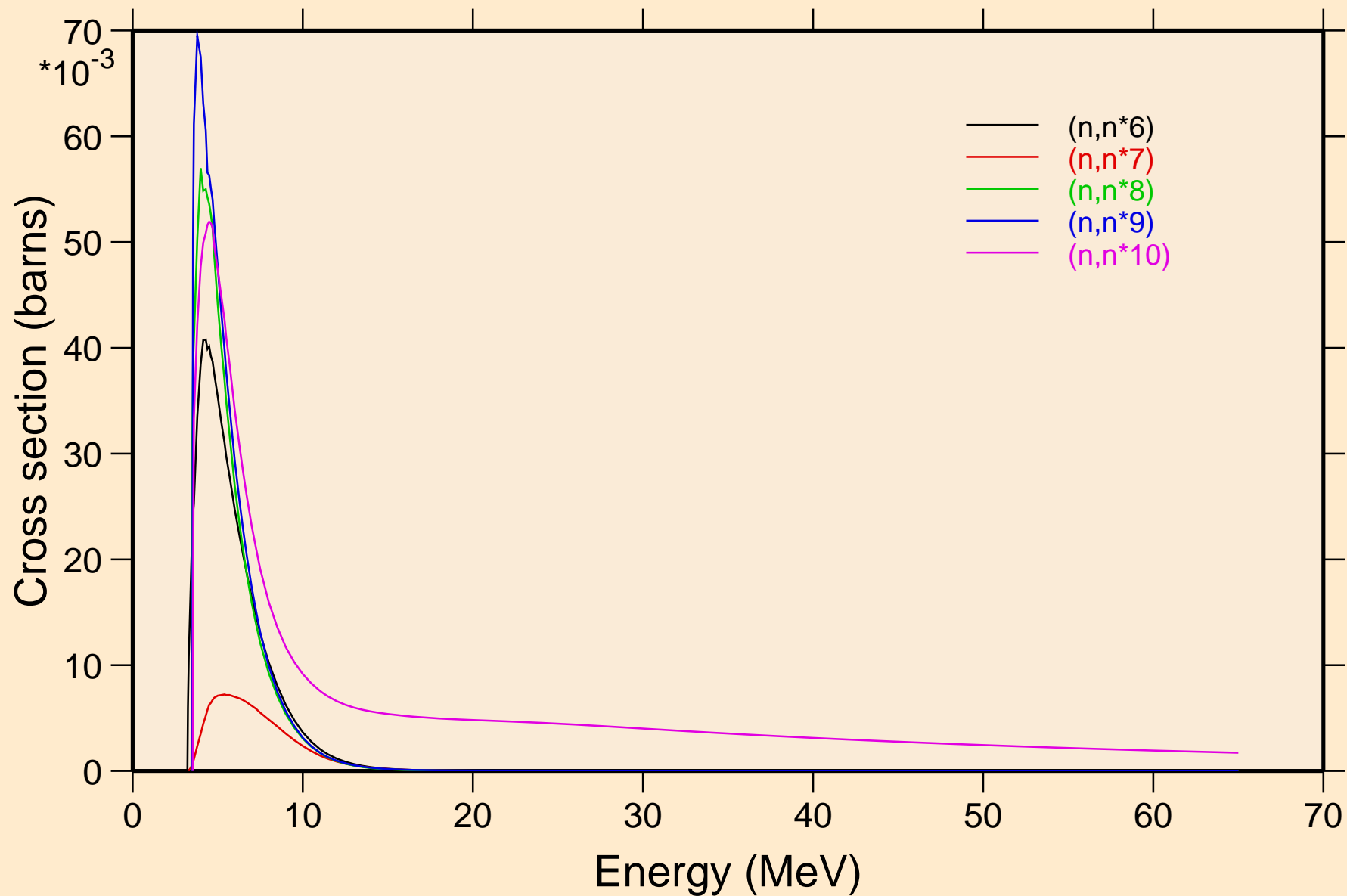

24-CR-54 FOR FENDL-3.2 FROM INDEN-1.0 BY NJOY2016.60+ OI Inelastic levels

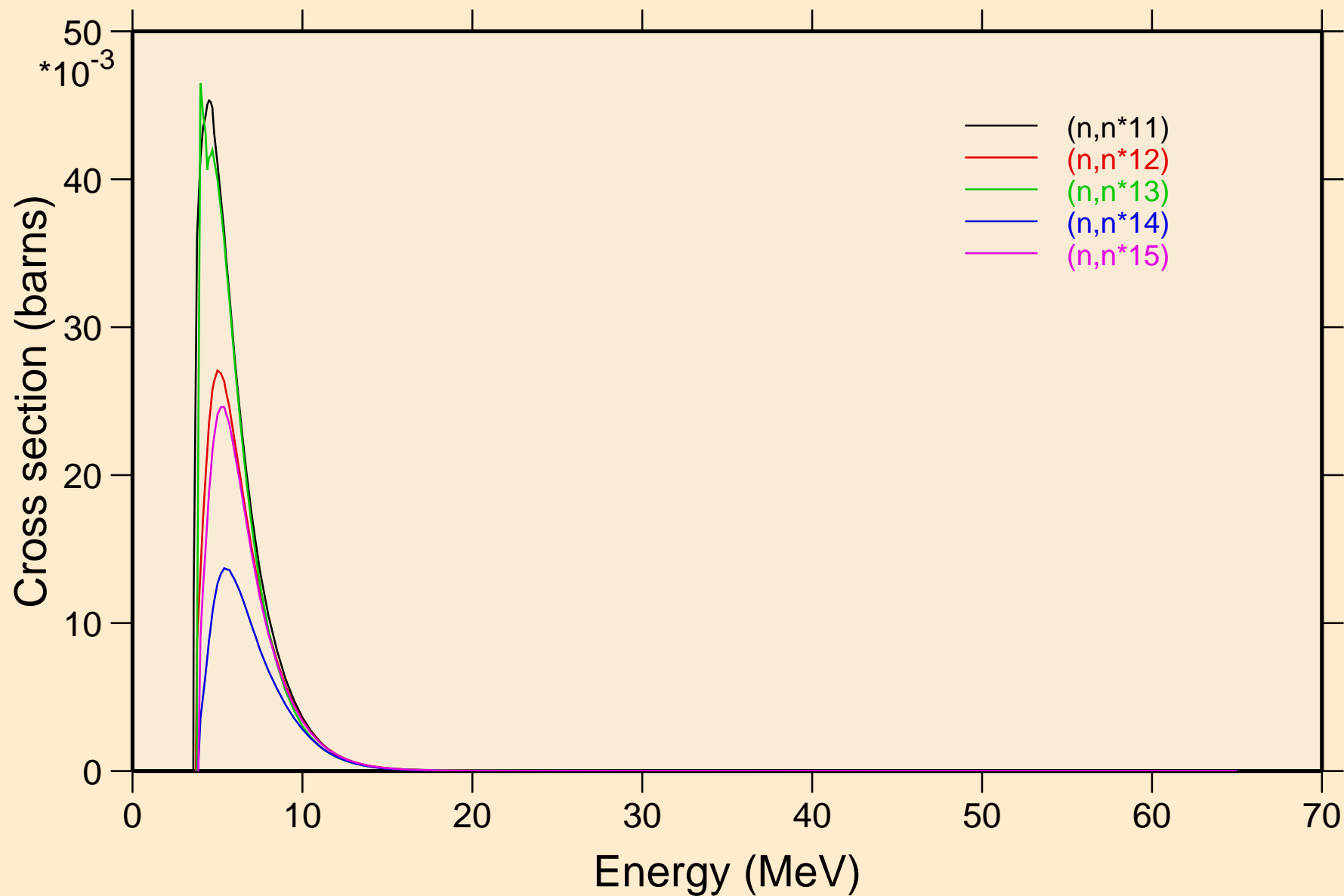

24-CR-54 FOR FENDL-3.2 FROM INDEN-1.0 BY NJOY2016.60+ OI Inelastic levels

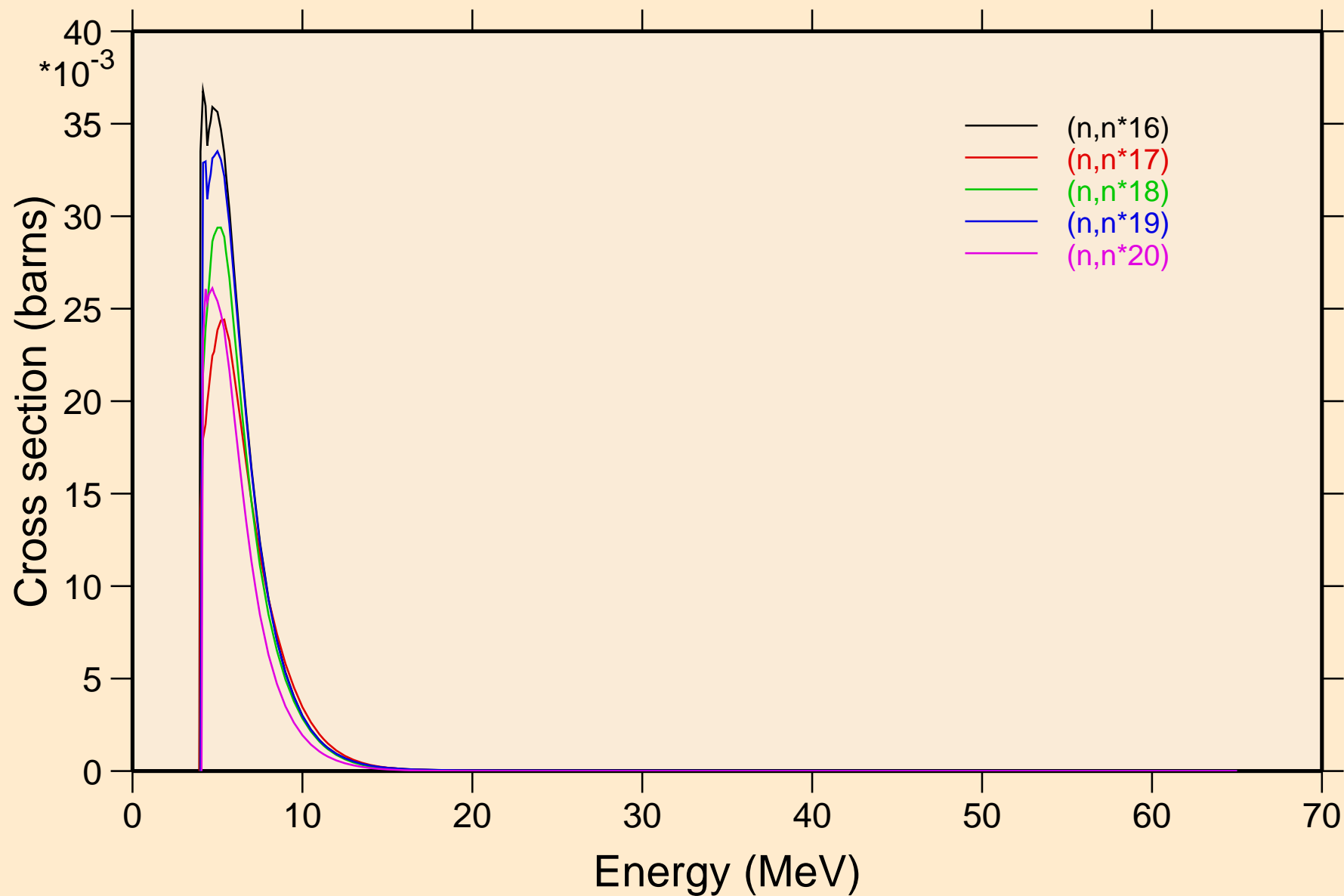

24-CR-54 FOR FENDL-3.2 FROM INDEN-1.0 BY NJOY2016.60+ OI Inelastic levels

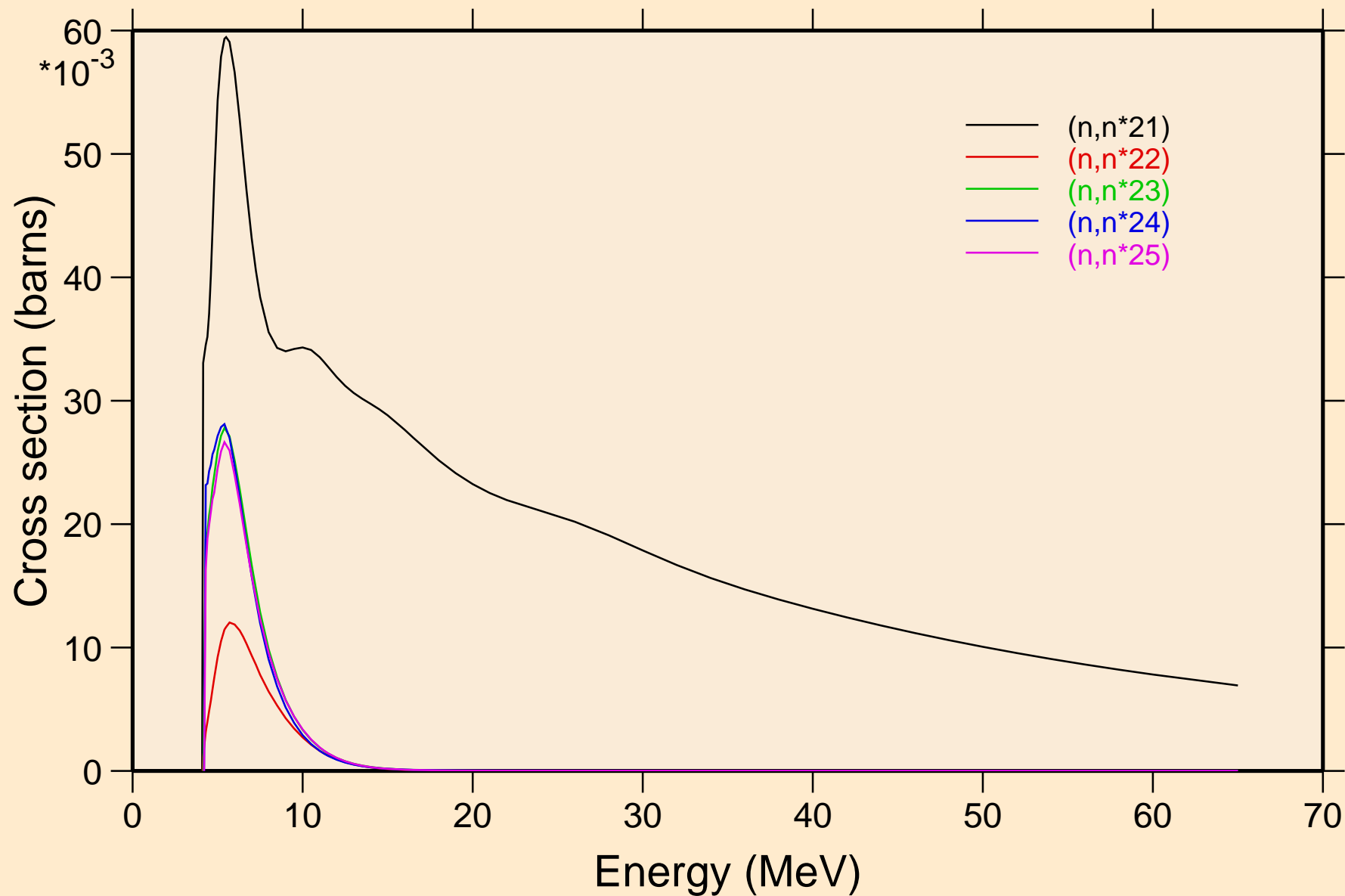

24-CR-54 FOR FENDL-3.2 FROM INDEN-1.0 BY NJOY2016.60+ OI Inelastic levels

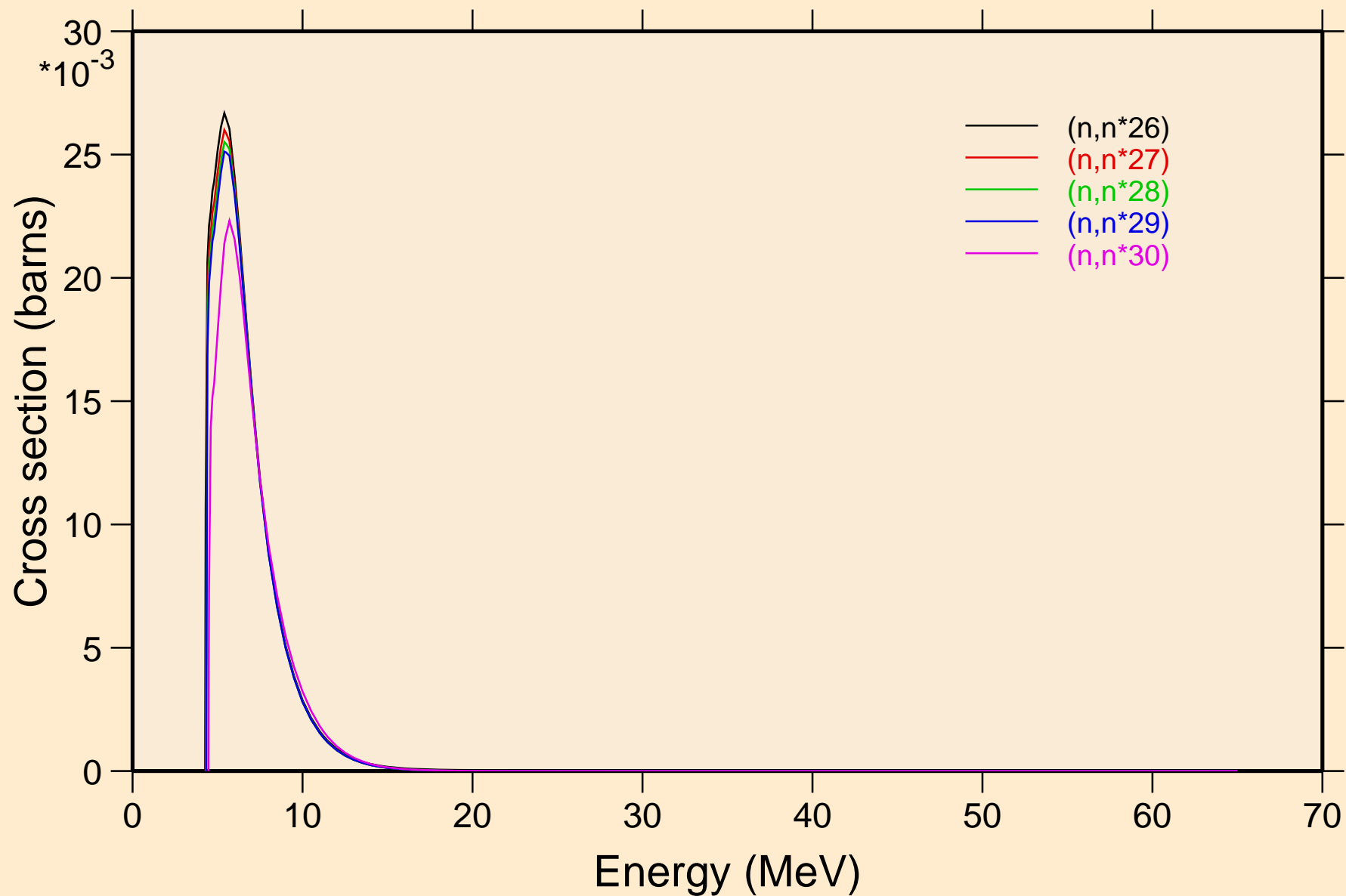

24-CR-54 FOR FENDL-3.2 FROM INDEN-1.0 BY NJOY2016.60+ OI Inelastic levels

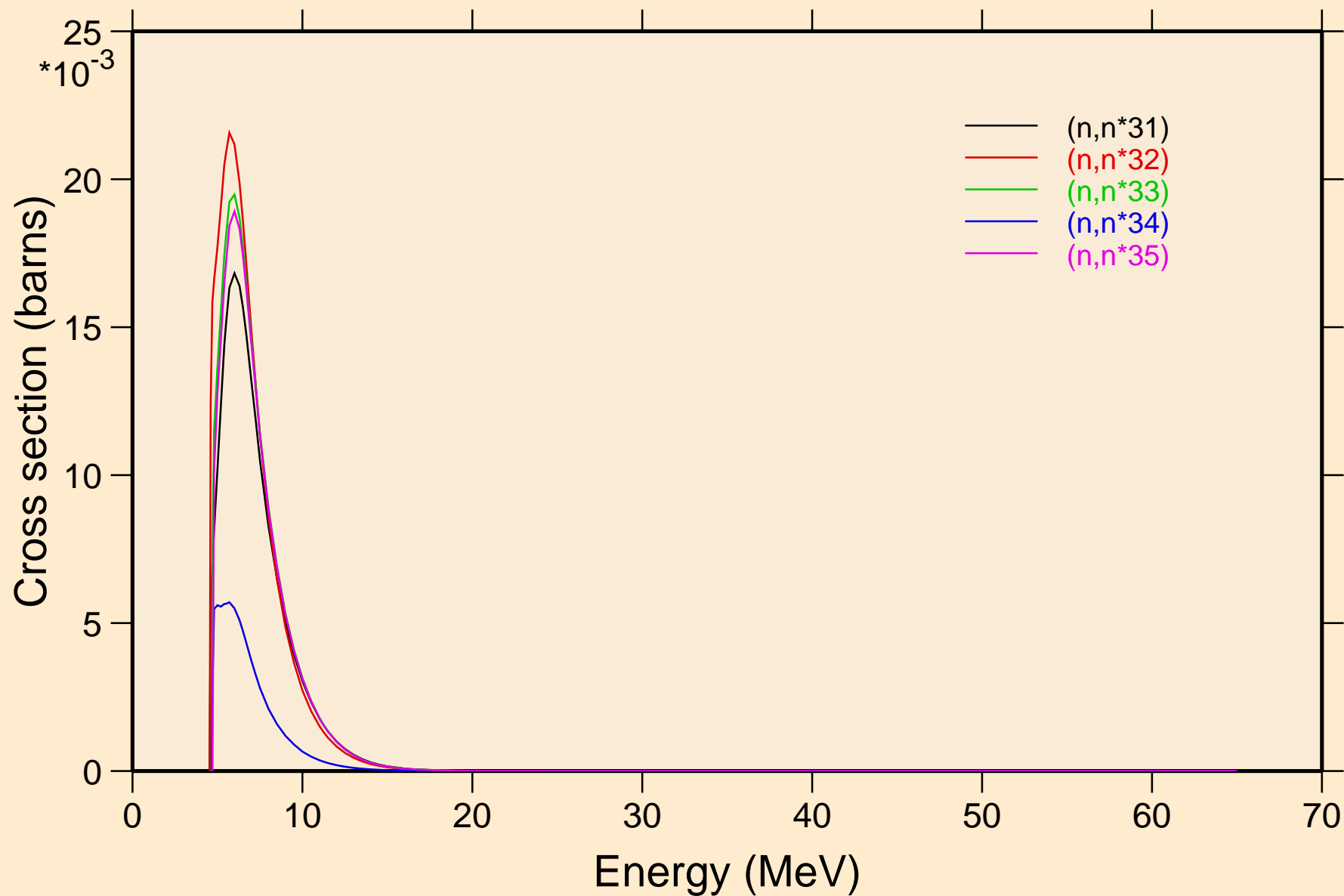

24-CR-54 FOR FENDL-3.2 FROM INDEN-1.0 BY NJOY2016.60+ OI Inelastic levels

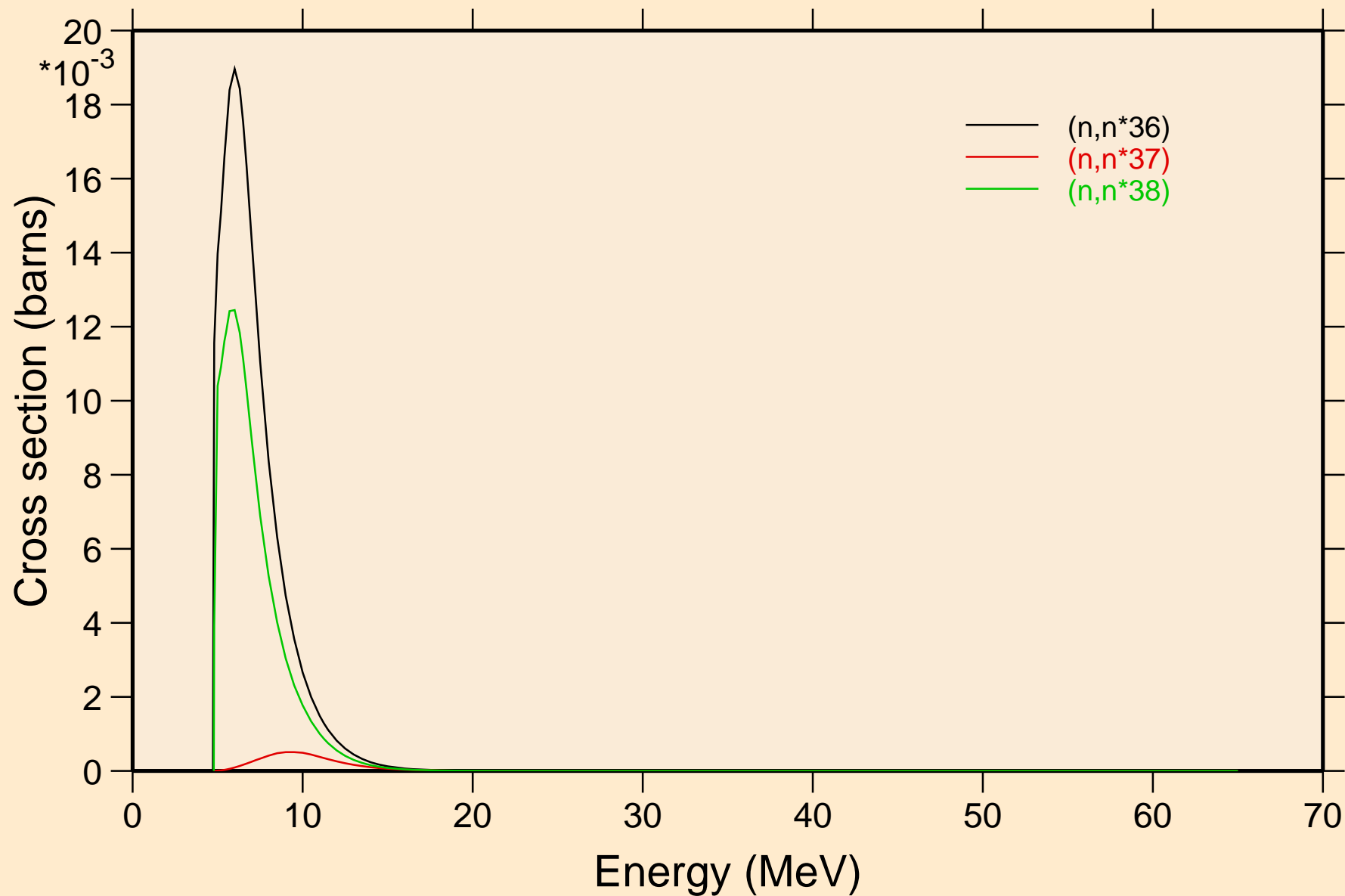

24-CR-54 FOR FENDL-3.2 FROM INDEN-1.0 BY NJOY2016.60+ OI
Threshold reactions

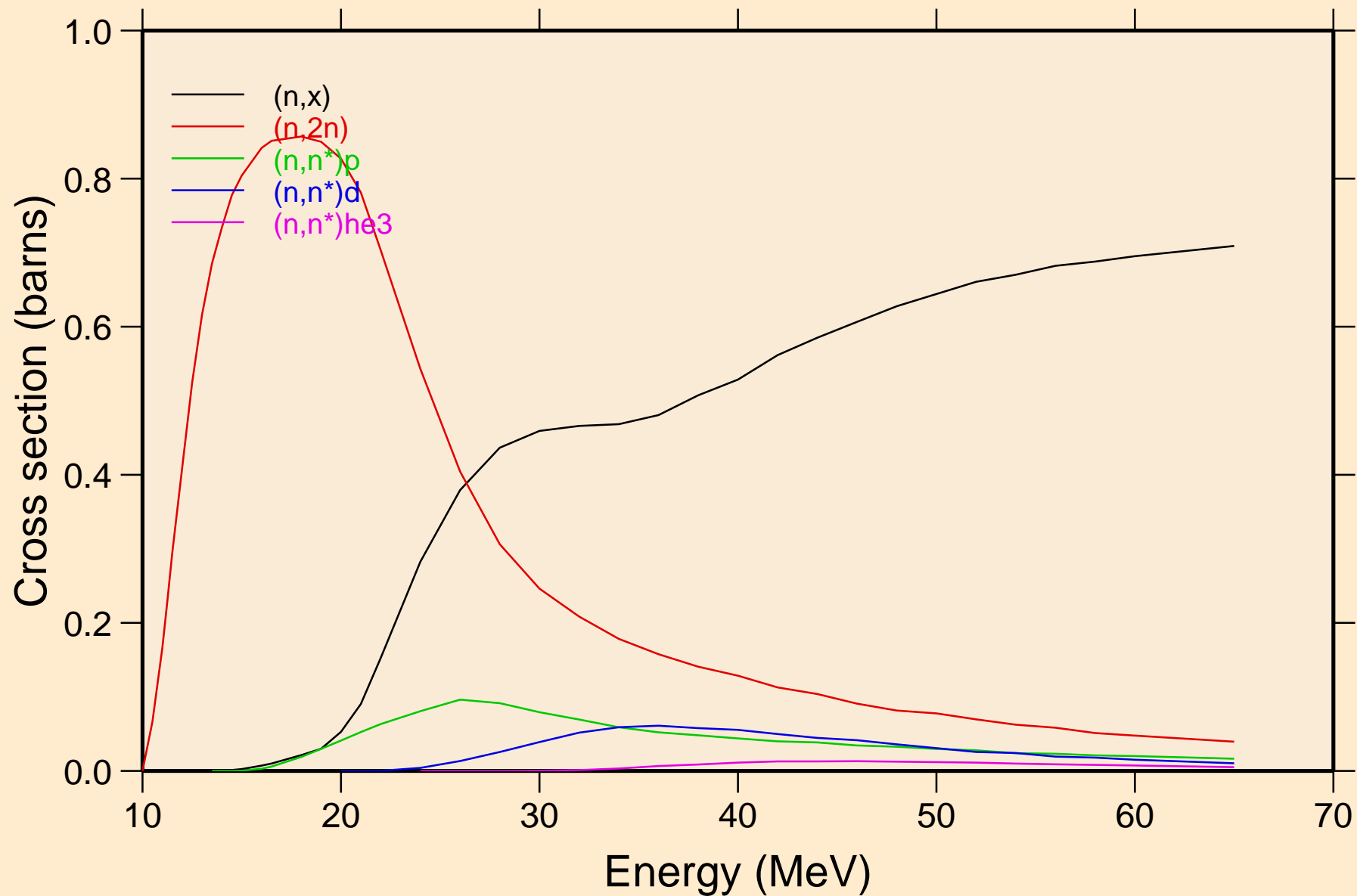

24-CR-54 FOR FENDL-3.2 FROM INDEN-1.0 BY NJOY2016.60+ OI Threshold reactions

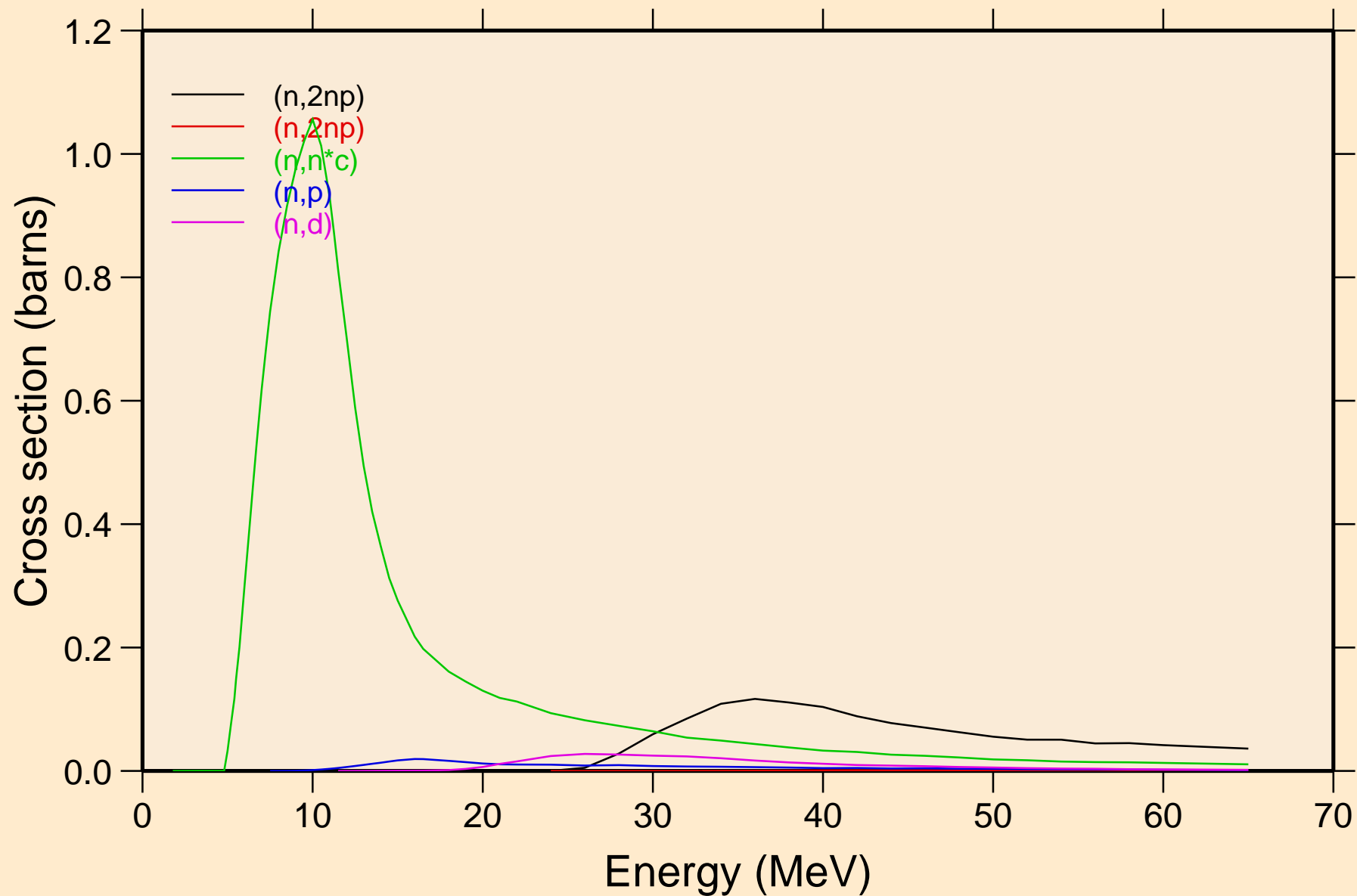

24-CR-54 FOR FENDL-3.2 FROM INDEN-1.0 BY NJOY2016.60+ OI Threshold reactions

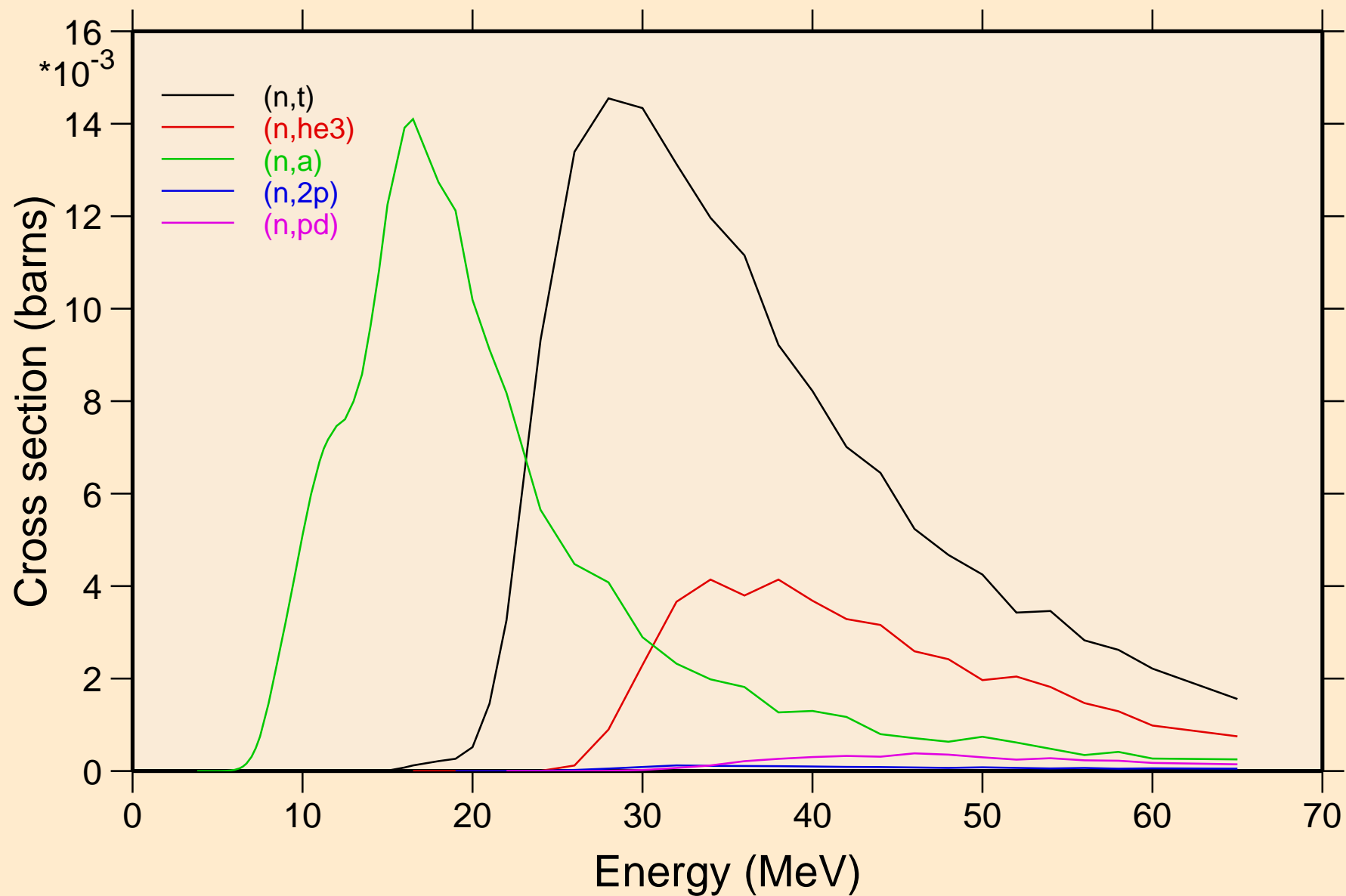

24-CR-54 FOR FENDL-3.2 FROM INDEN-1.0 BY NJOY2016.60+ OI
Threshold reactions

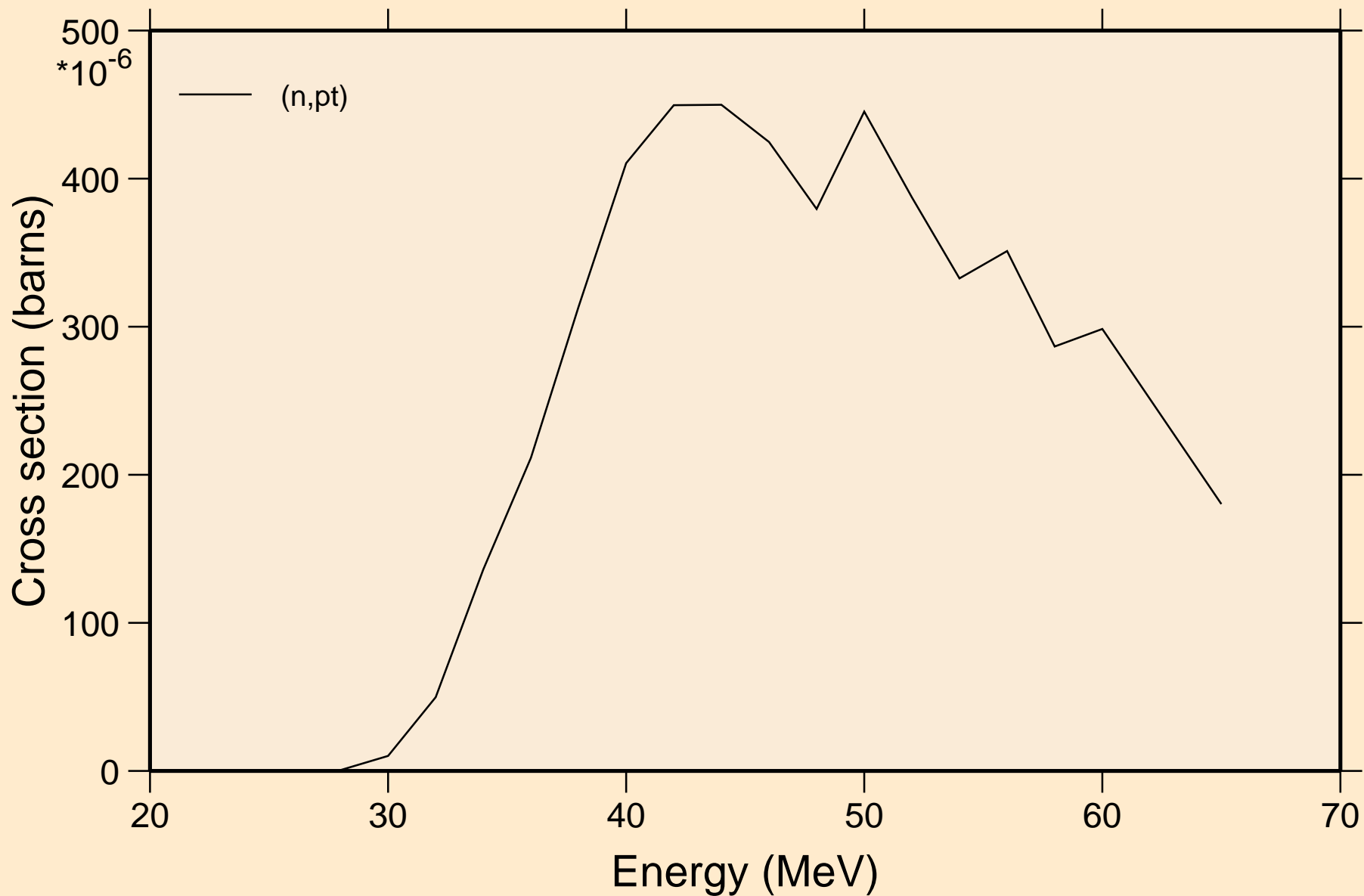

24-CR-54 FOR FENDL-3.2 FROM INDEN-1.0 BY NJOY2016.60+ OI

Threshold reactions

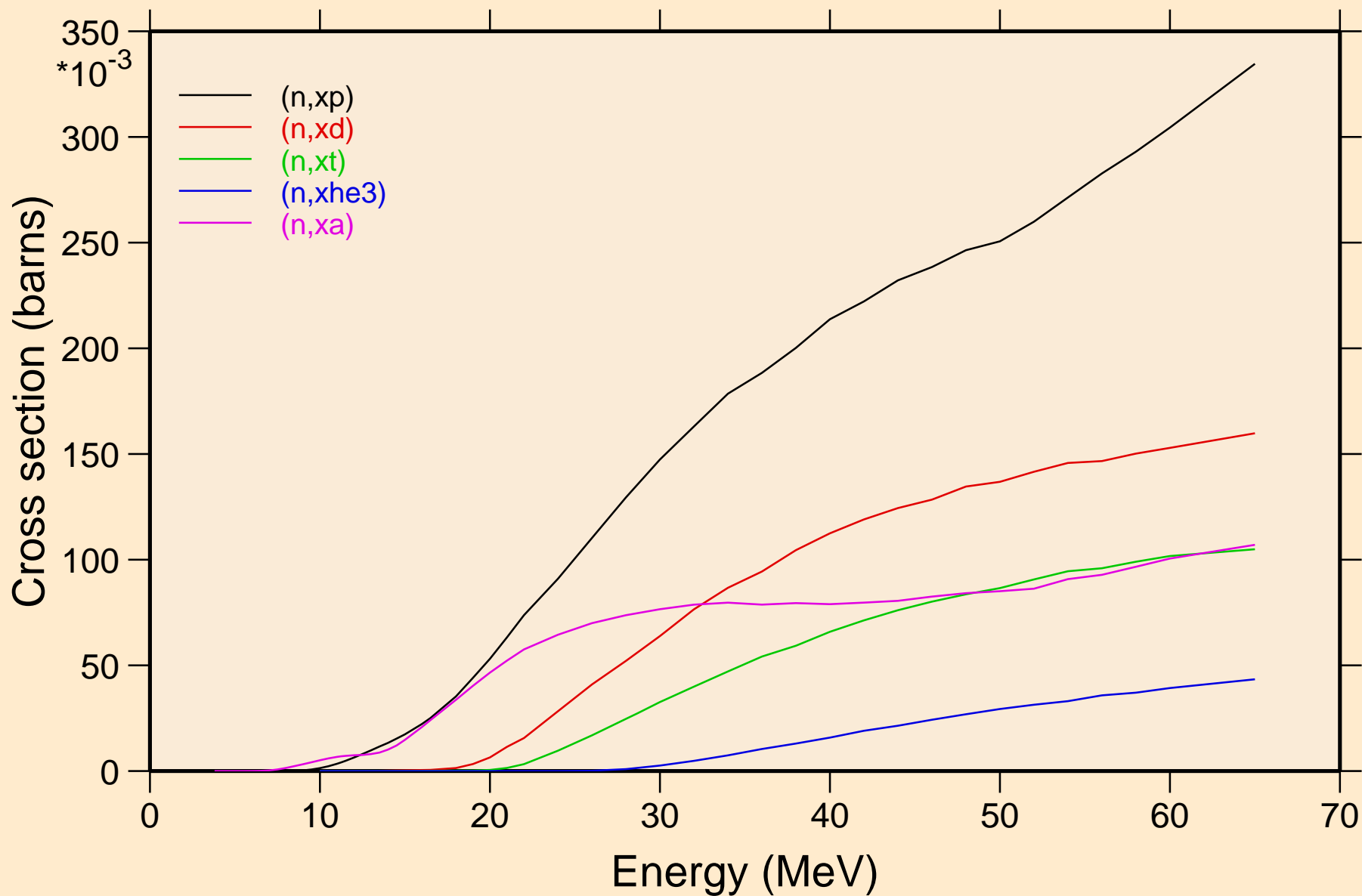

24-CR-54 FOR FENDL-3.2 FROM INDEN-1.0 BY NJOY2016.60+ OI
Threshold reactions

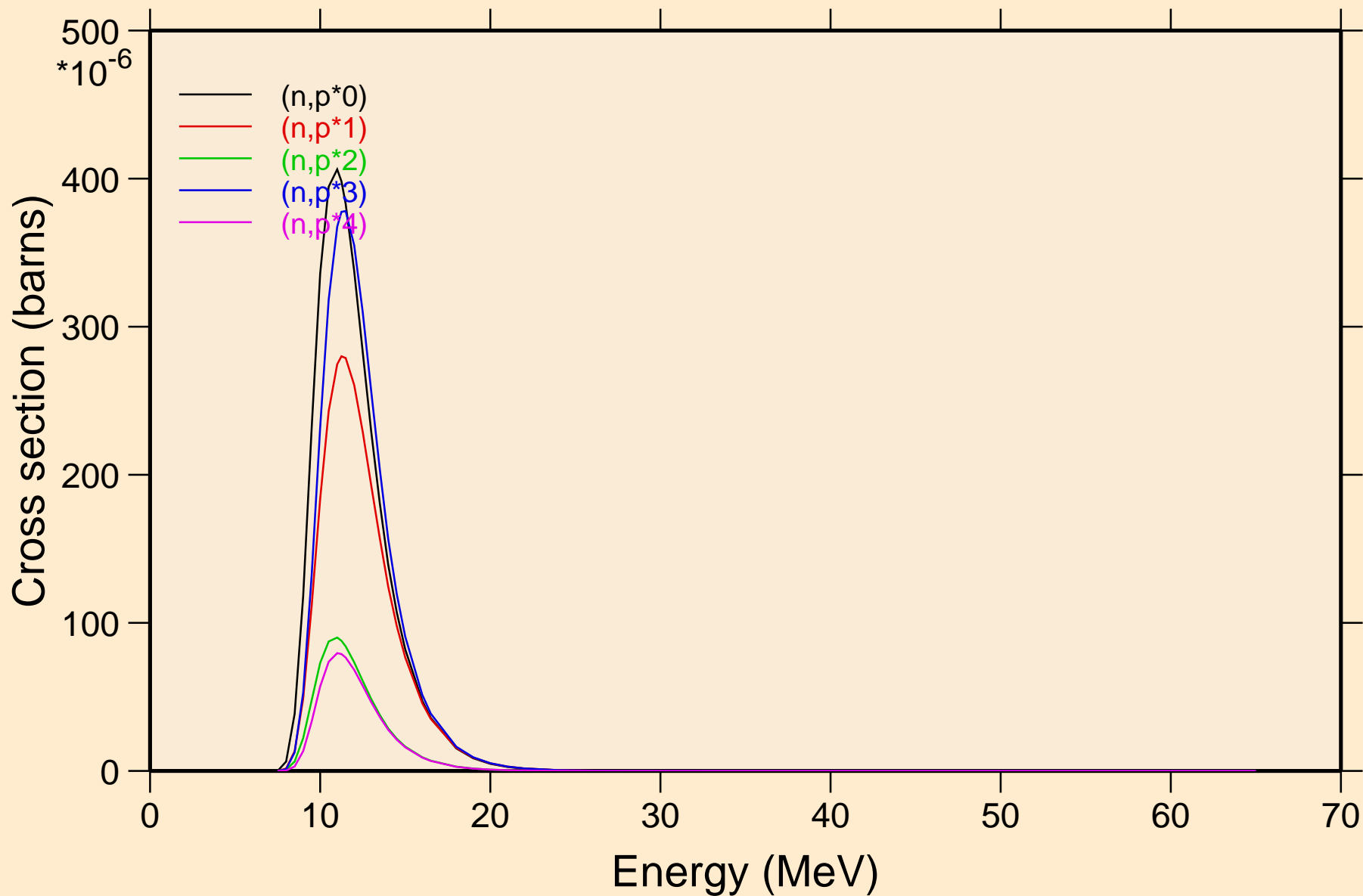

24-CR-54 FOR FENDL-3.2 FROM INDEN-1.0 BY NJOY2016.60+ OI

Threshold reactions

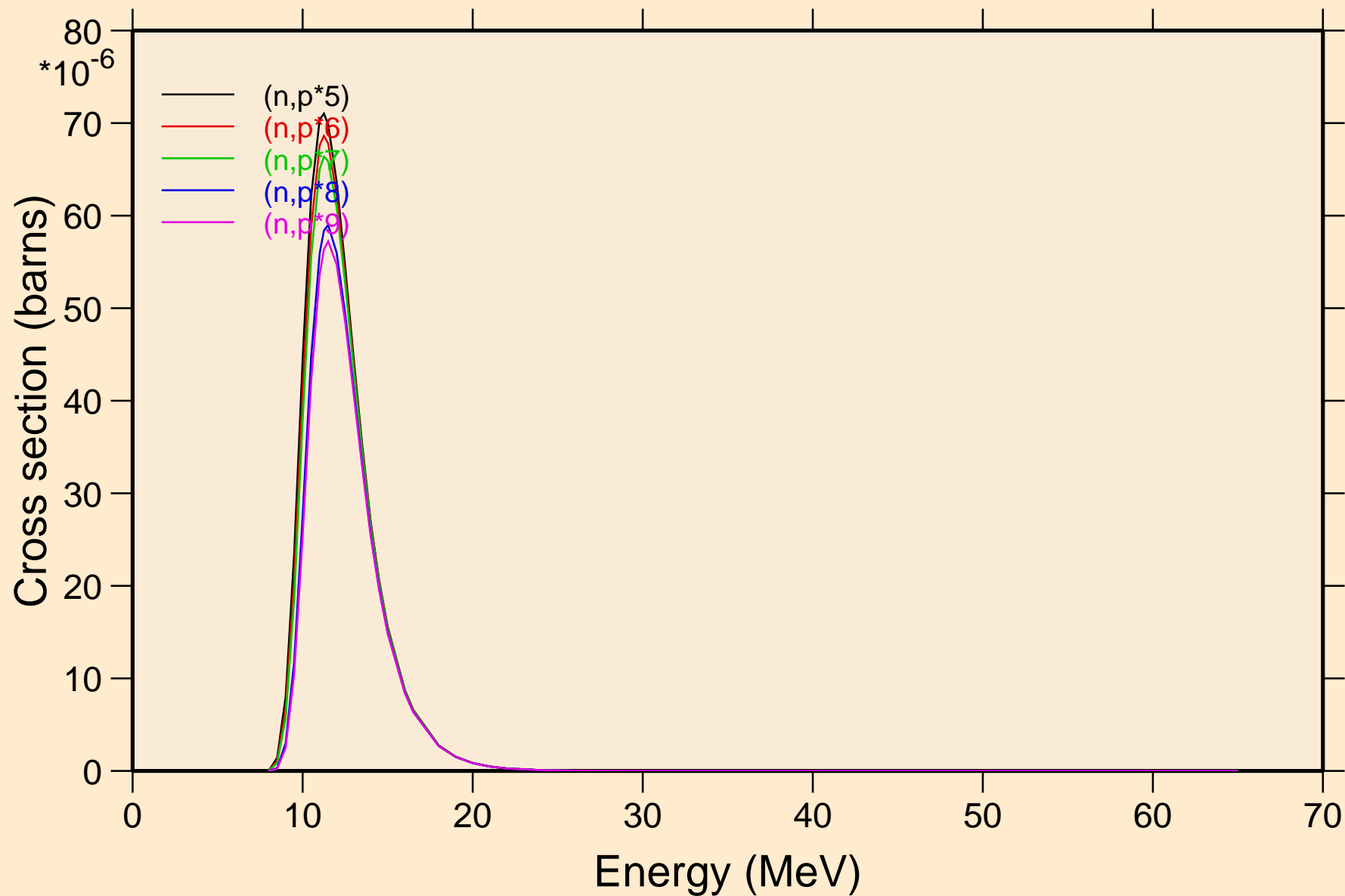

24-CR-54 FOR FENDL-3.2 FROM INDEN-1.0 BY NJOY2016.60+ OI

Threshold reactions

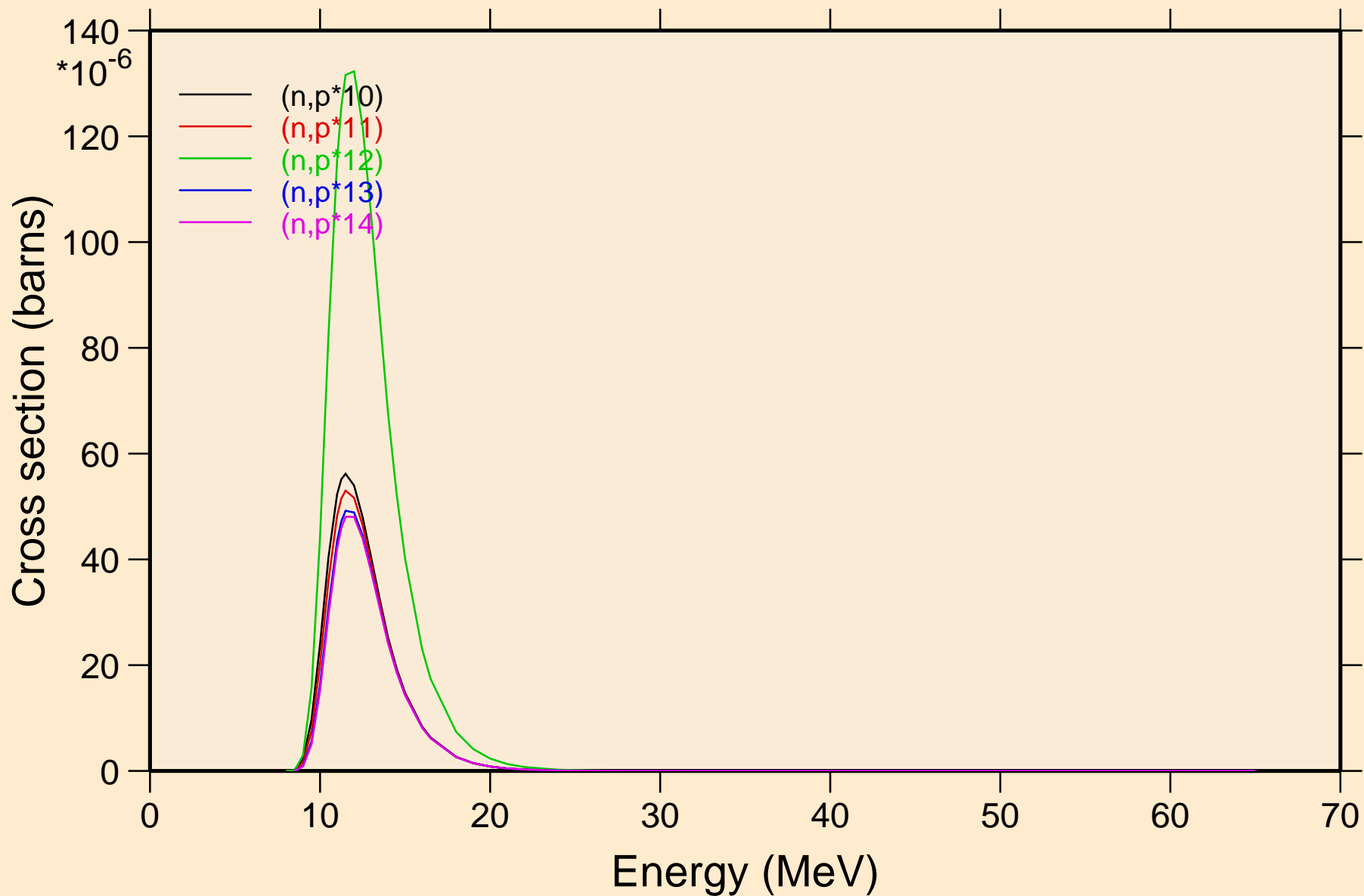

24-CR-54 FOR FENDL-3.2 FROM INDEN-1.0 BY NJOY2016.60+ OI Threshold reactions

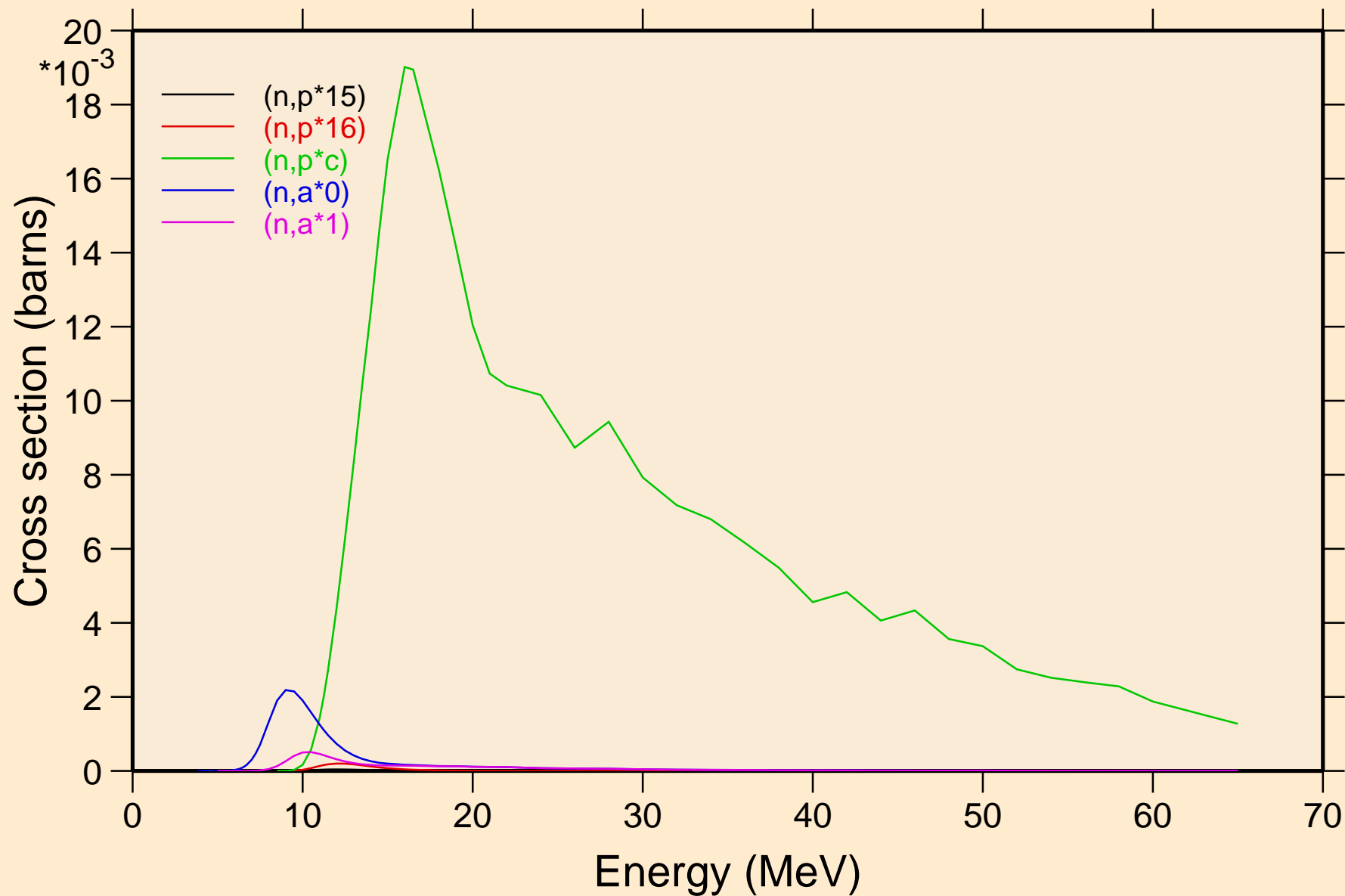

24-CR-54 FOR FENDL-3.2 FROM INDEN-1.0 BY NJOY2016.60+ OI
Threshold reactions

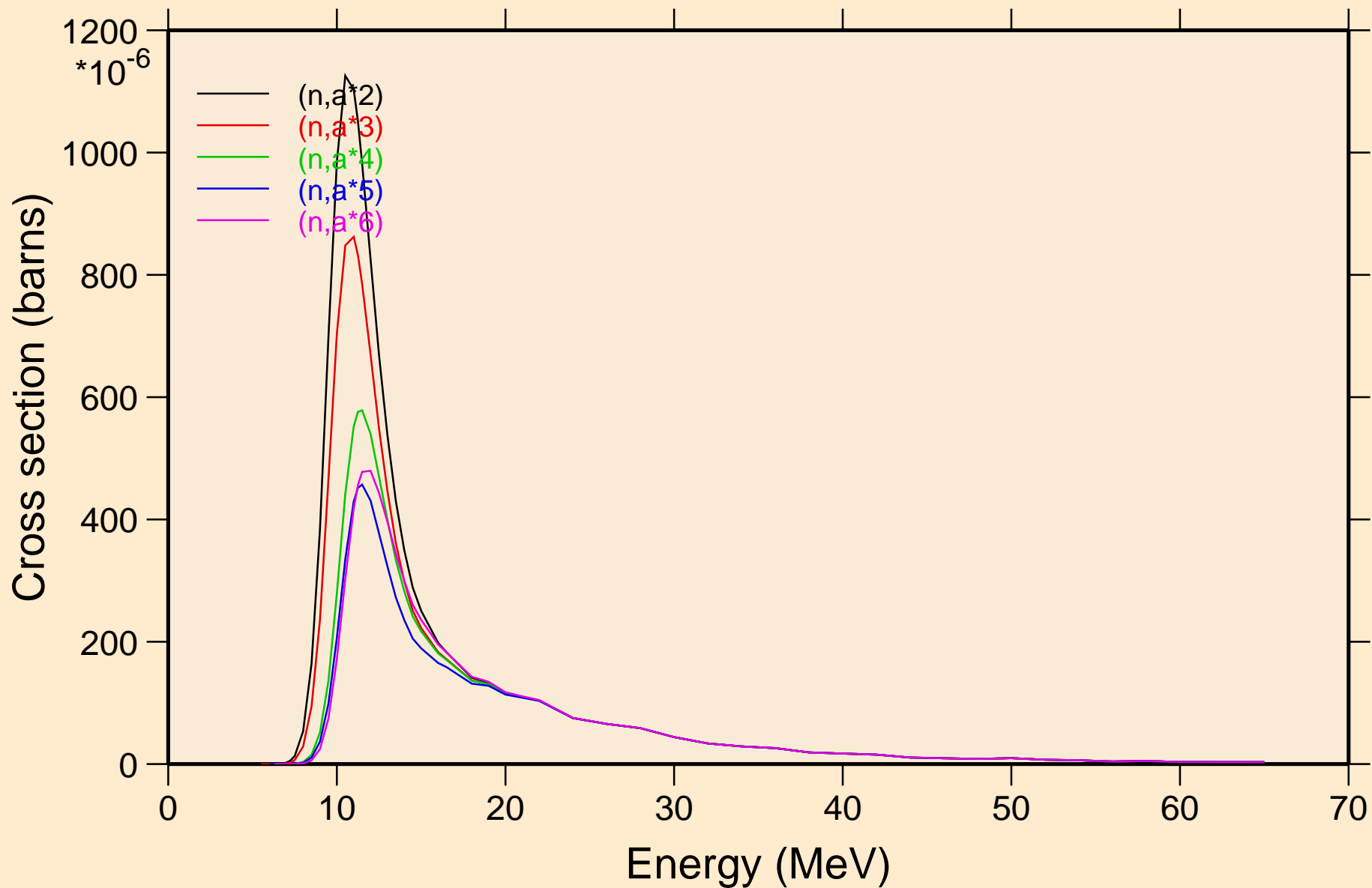

24-CR-54 FOR FENDL-3.2 FROM INDEN-1.0 BY NJOY2016.60+ OI

Threshold reactions

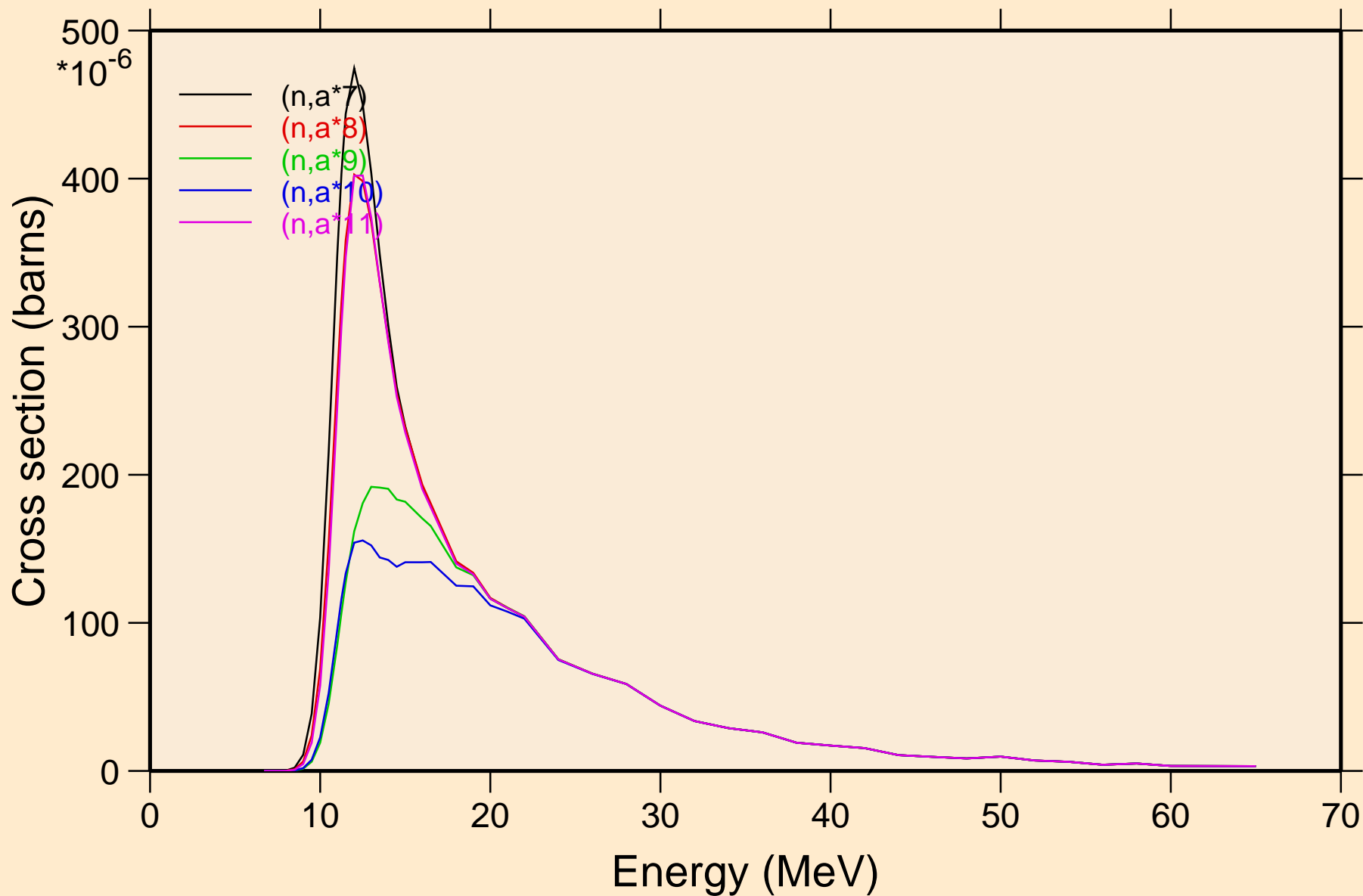

24-CR-54 FOR FENDL-3.2 FROM INDEN-1.0 BY NJOY2016.60+ OI

Threshold reactions

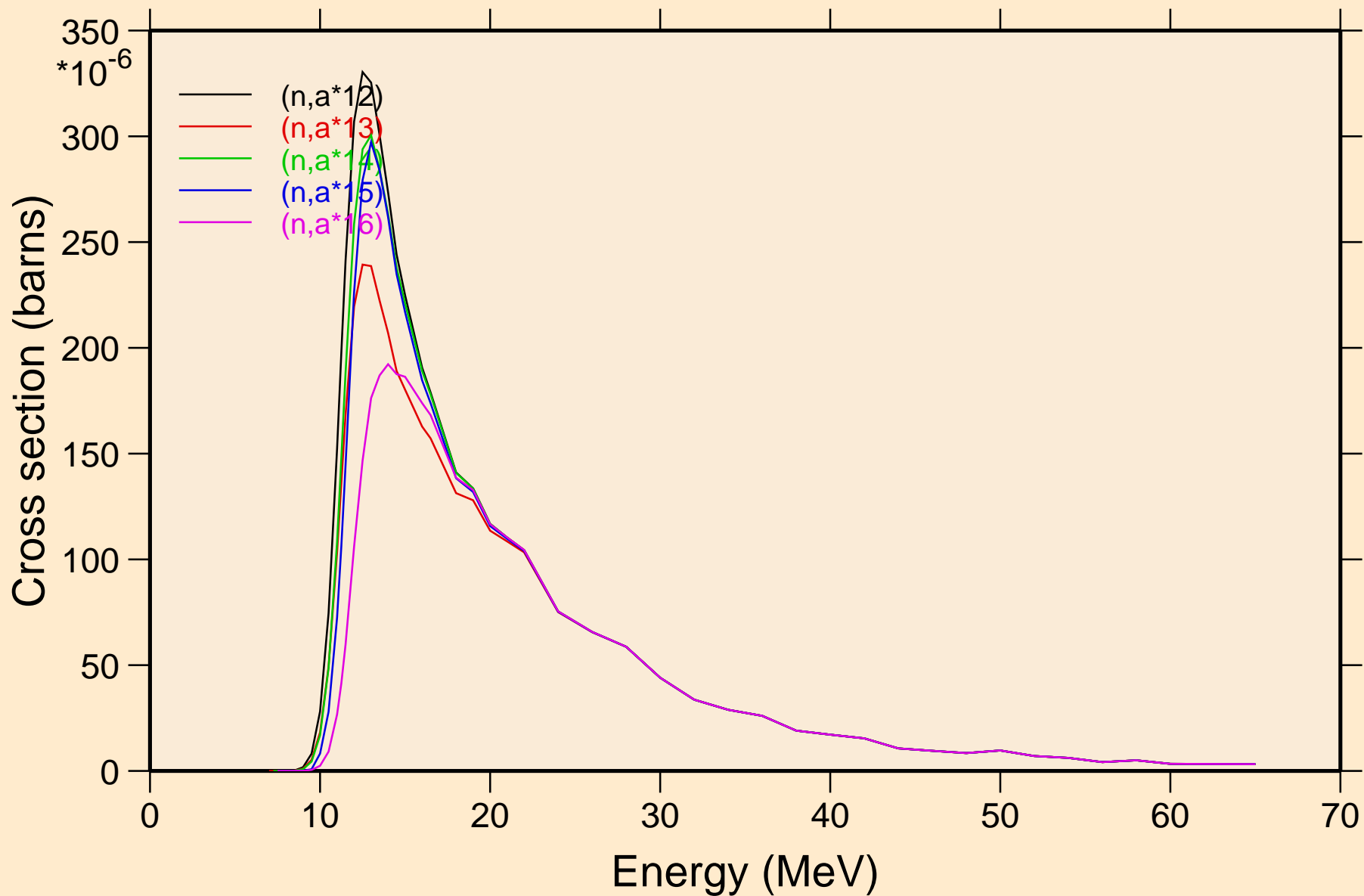

24-CR-54 FOR FENDL-3.2 FROM INDEN-1.0 BY NJOY2016.60+ OI

Threshold reactions

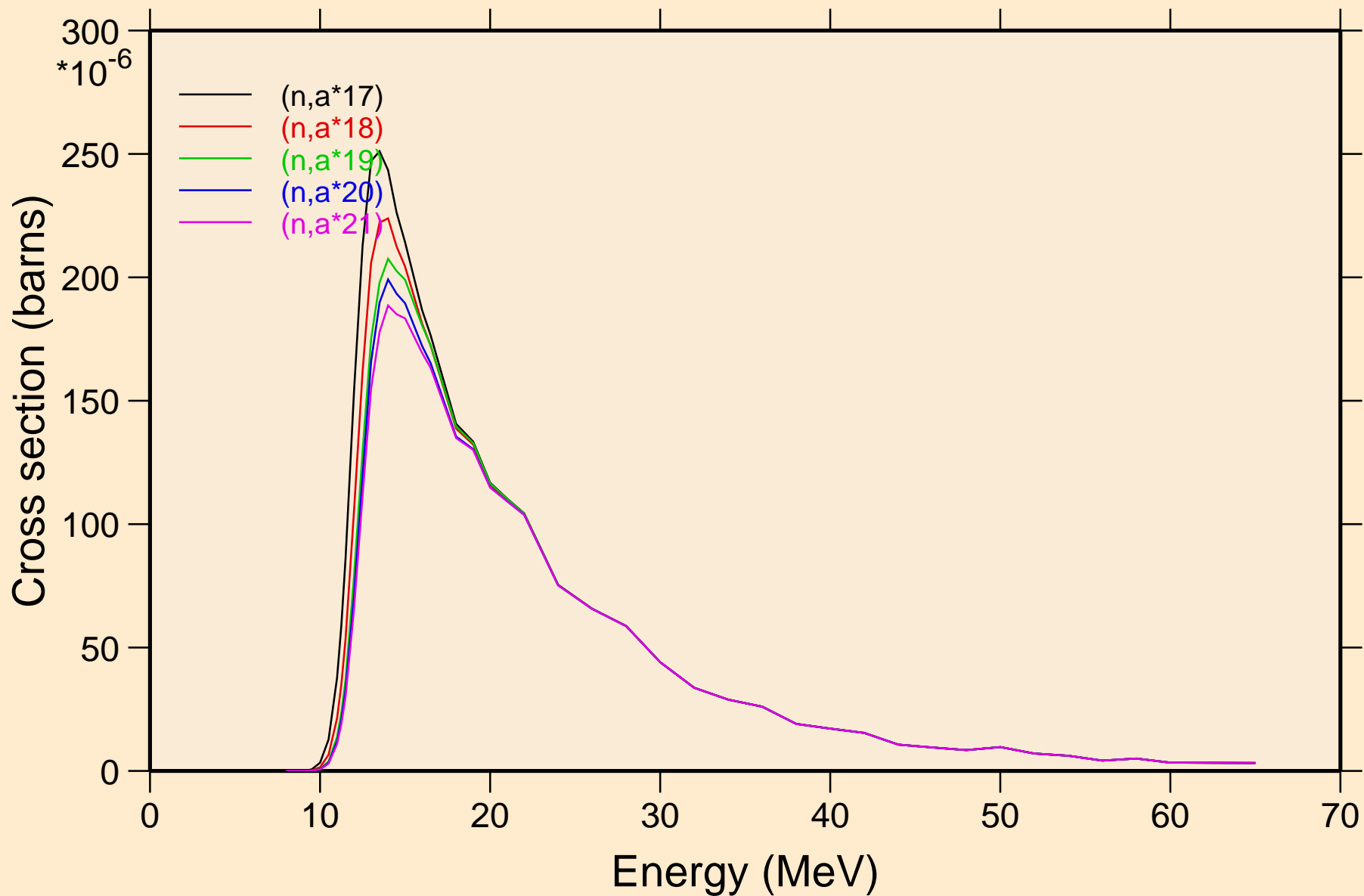

24-CR-54 FOR FENDL-3.2 FROM INDEN-1.0 BY NJOY2016.60+ OI
Threshold reactions

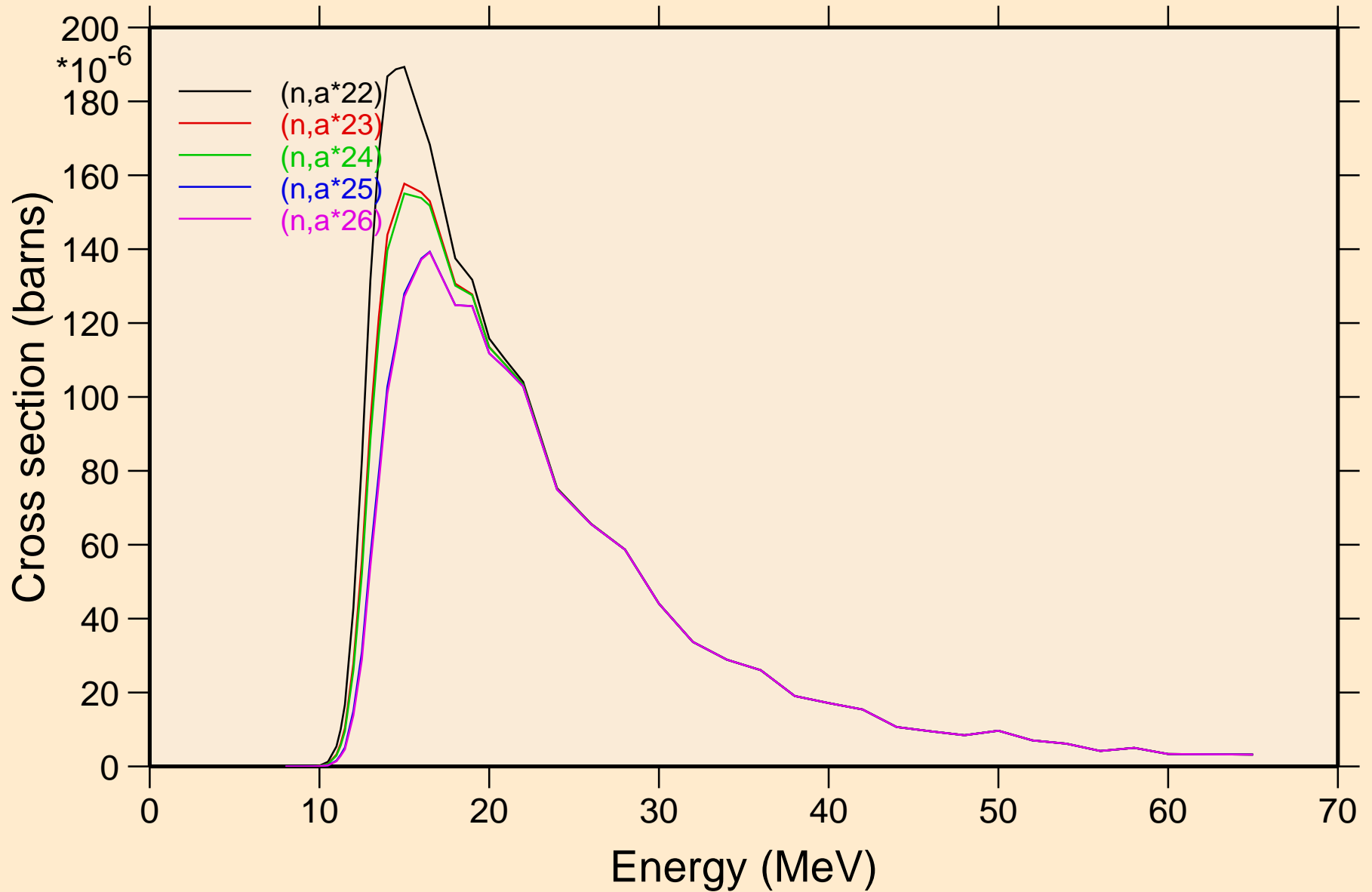

24-CR-54 FOR FENDL-3.2 FROM INDEN-1.0 BY NJOY2016.60+ OI

Threshold reactions

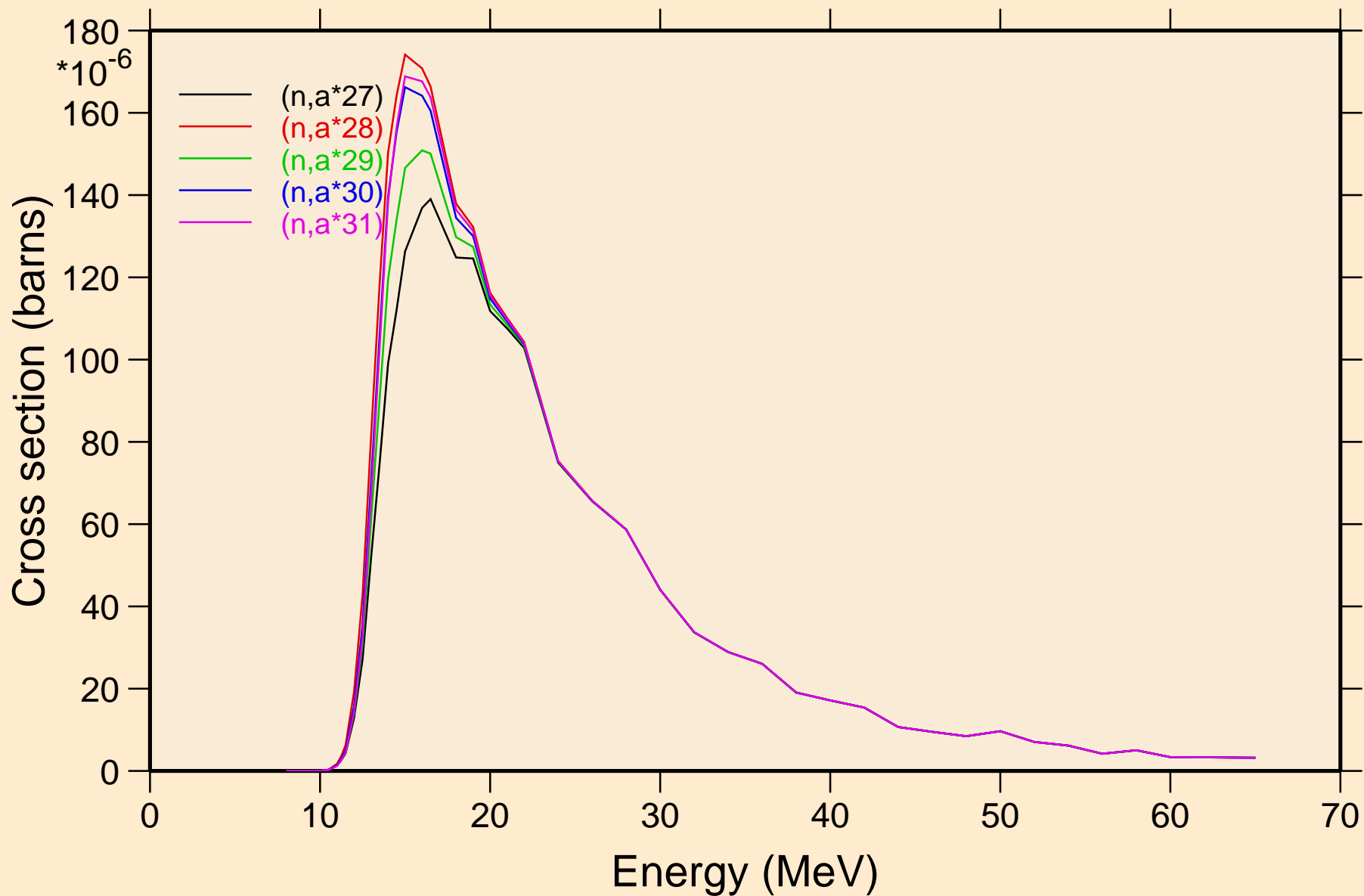

24-CR-54 FOR FENDL-3.2 FROM INDEN-1.0 BY NJOY2016.60+ OI Threshold reactions

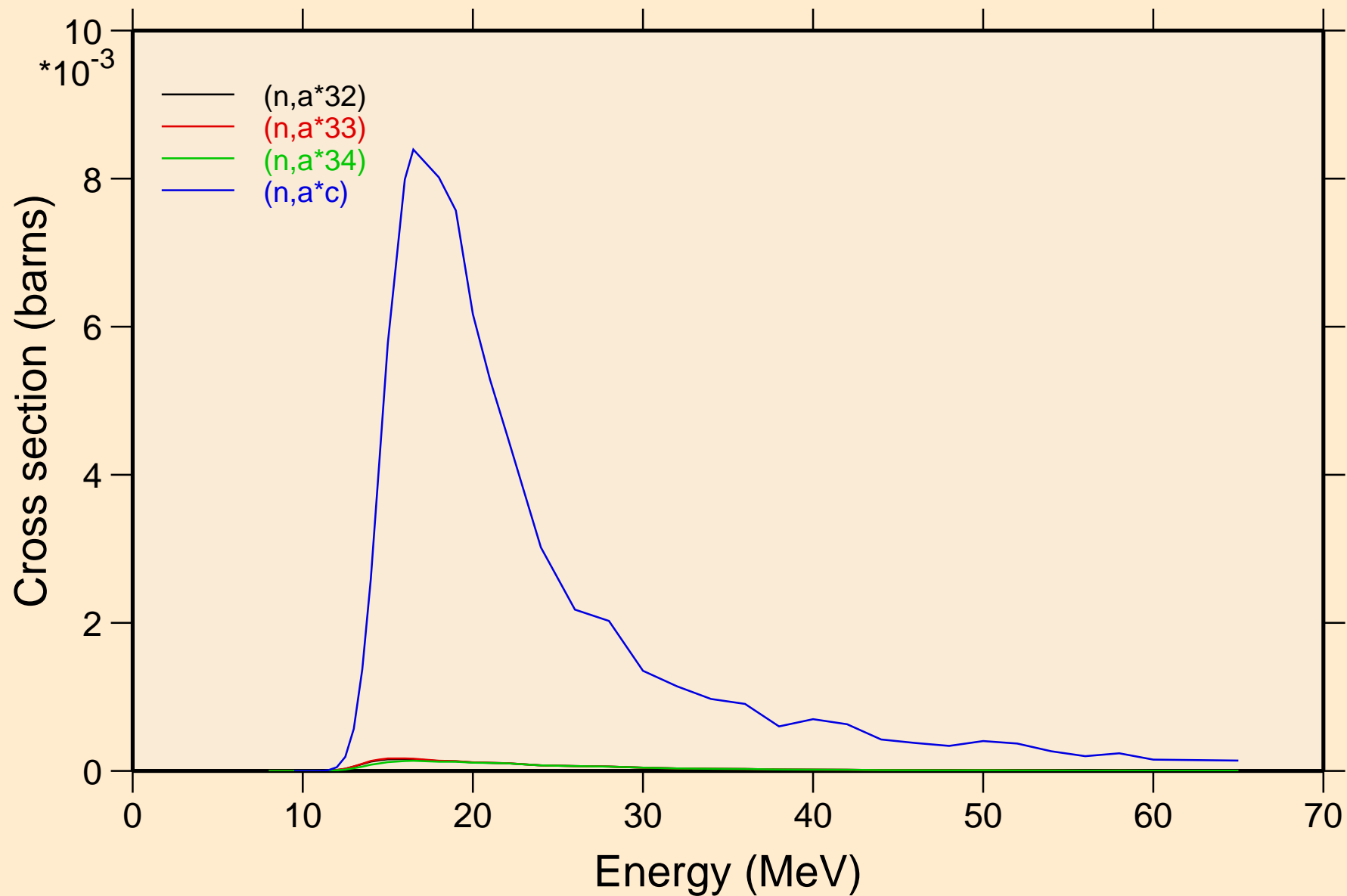

24-CR-54 FOR FENDL-3.2 FROM INDEN-1.0 BY NJOY2016.60+ OI
angular distribution for elastic

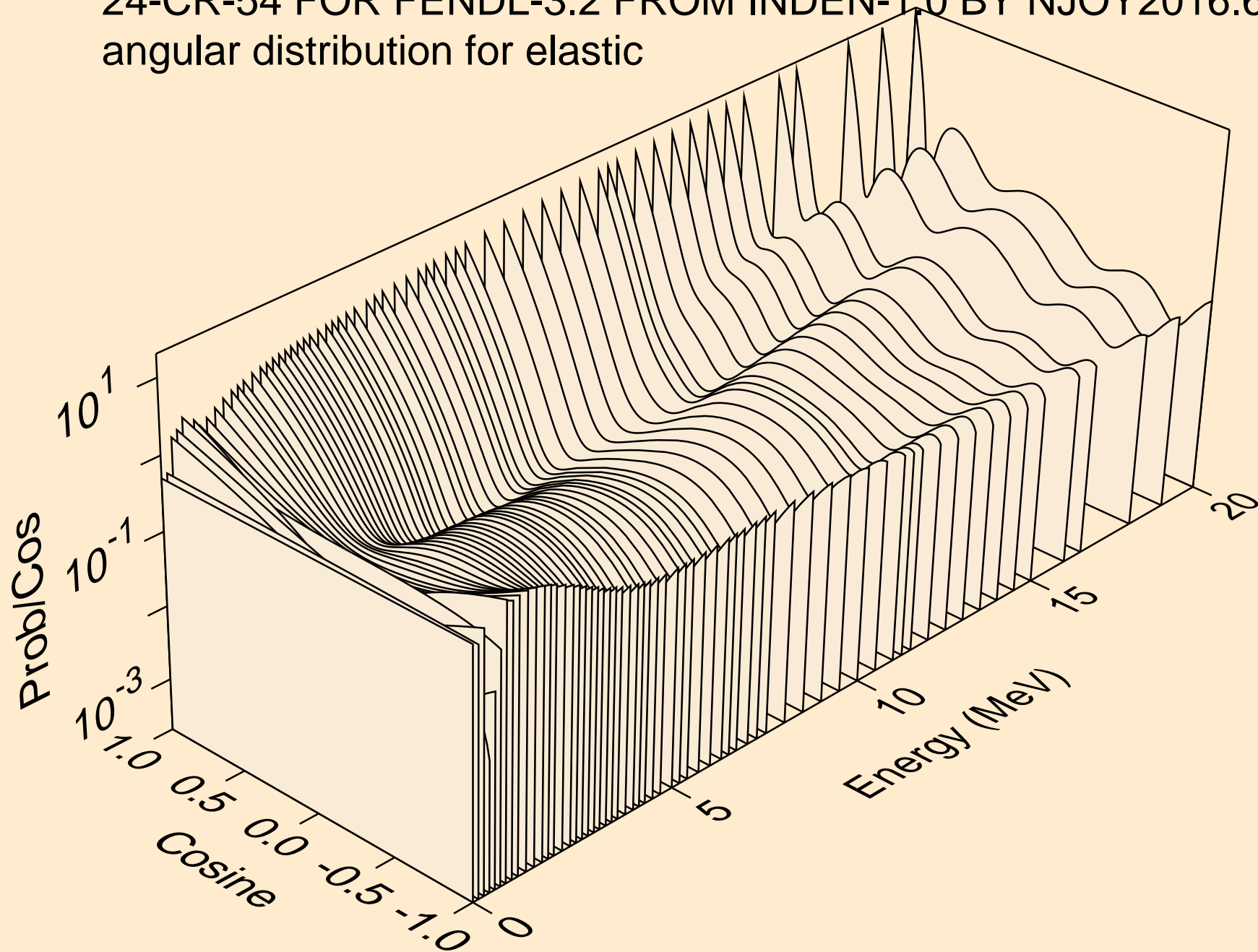

24-CR-54 FOR FENDL-3.2 FROM INDEN-1.0 BY NJOY2016.60+ OI
angular distribution for elastic

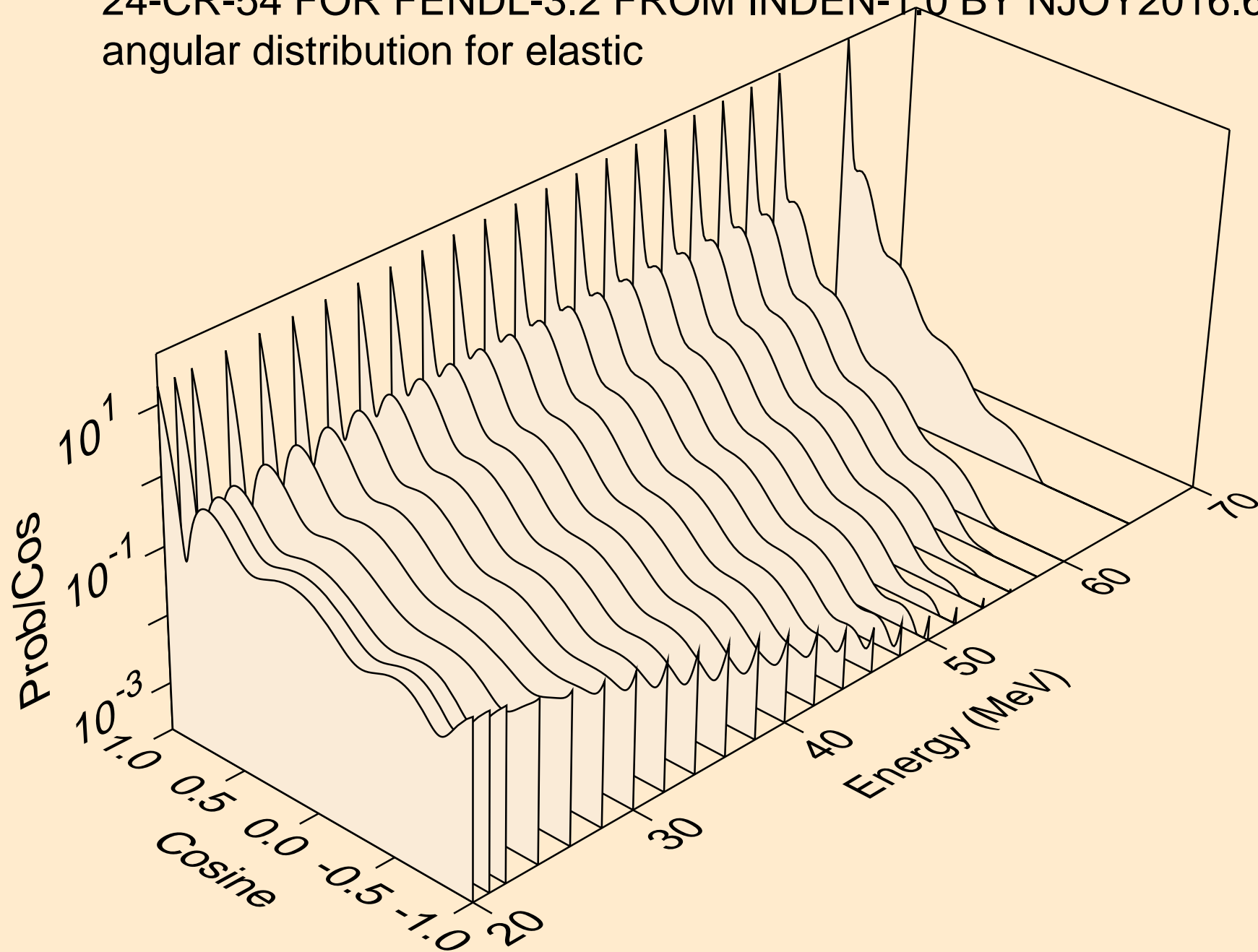

24-CR-54 FOR FENDL-3.2 FROM INDEN-1.0 BY NJOY2016.60+ OI
angular distribution for (n,n*1)

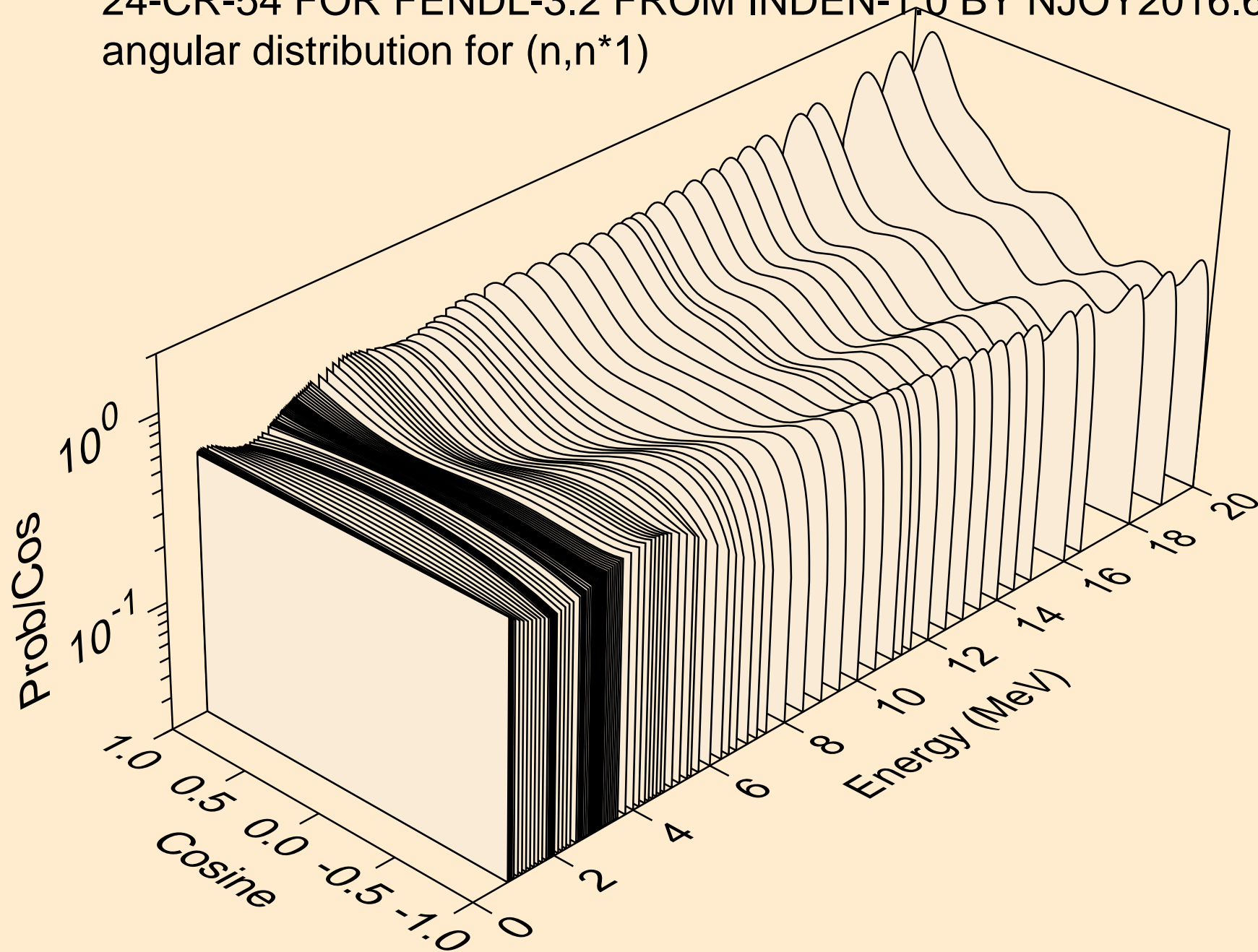

24-CR-54 FOR FENDL-3.2 FROM INDEN-1.0 BY NJOY2016.60+ OI
angular distribution for (n,n*1)

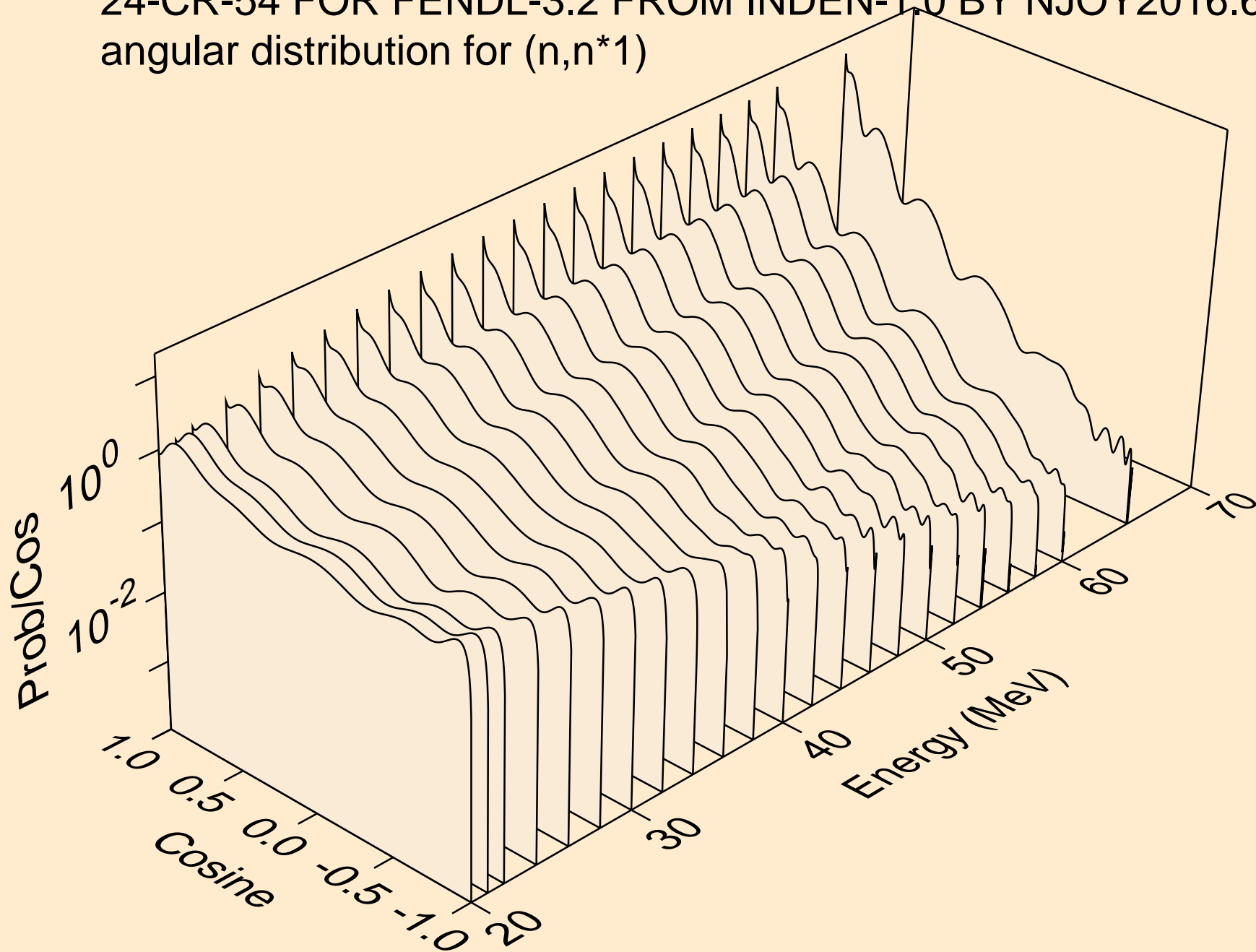

24-CR-54 FOR FENDL-3.2 FROM INDEN-1.0 BY NJOY2016.60+ OI
angular distribution for (n,n*2)

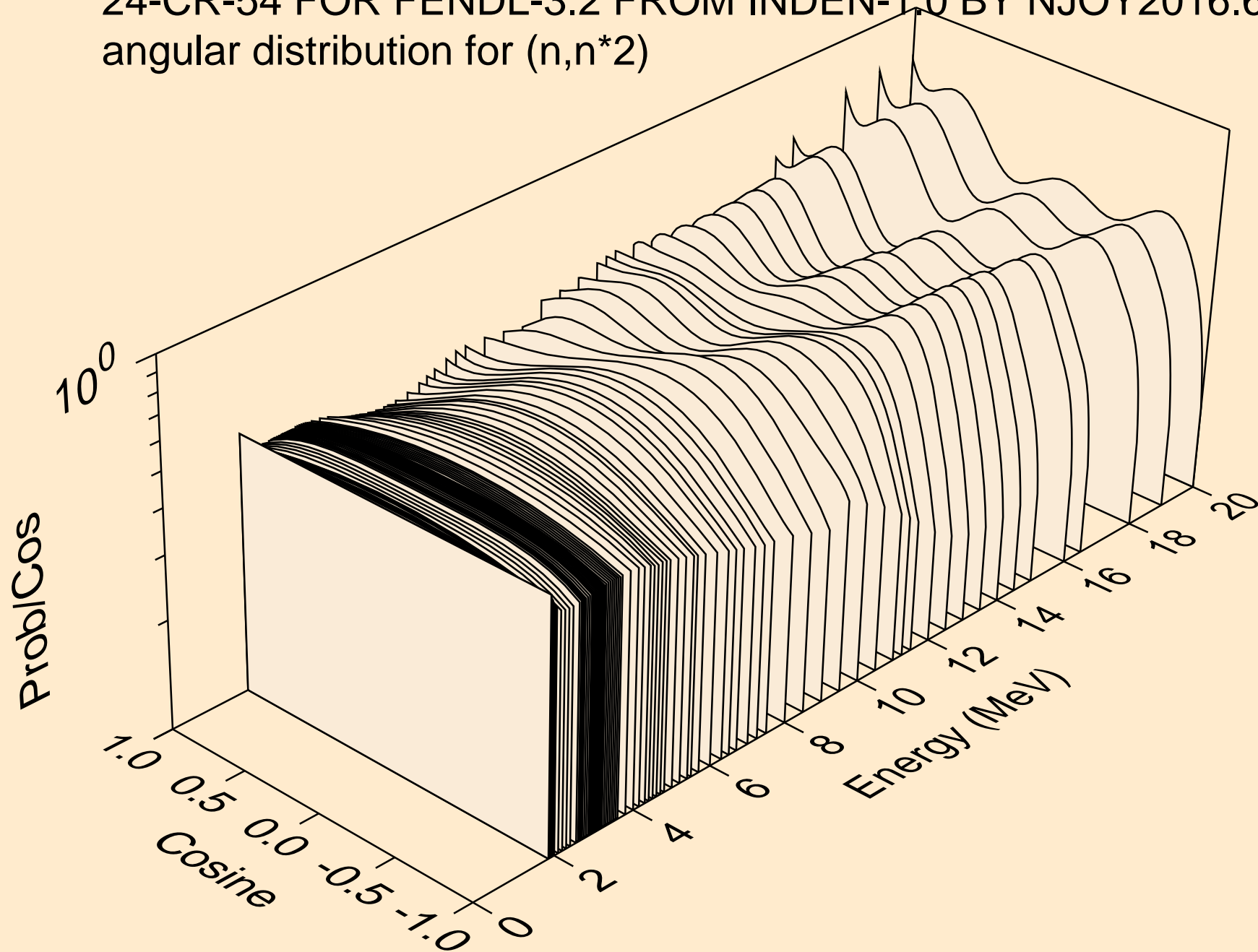

24-CR-54 FOR FENDL-3.2 FROM INDEN-1.0 BY NJOY2016.60+ OI
angular distribution for (n,n*2)

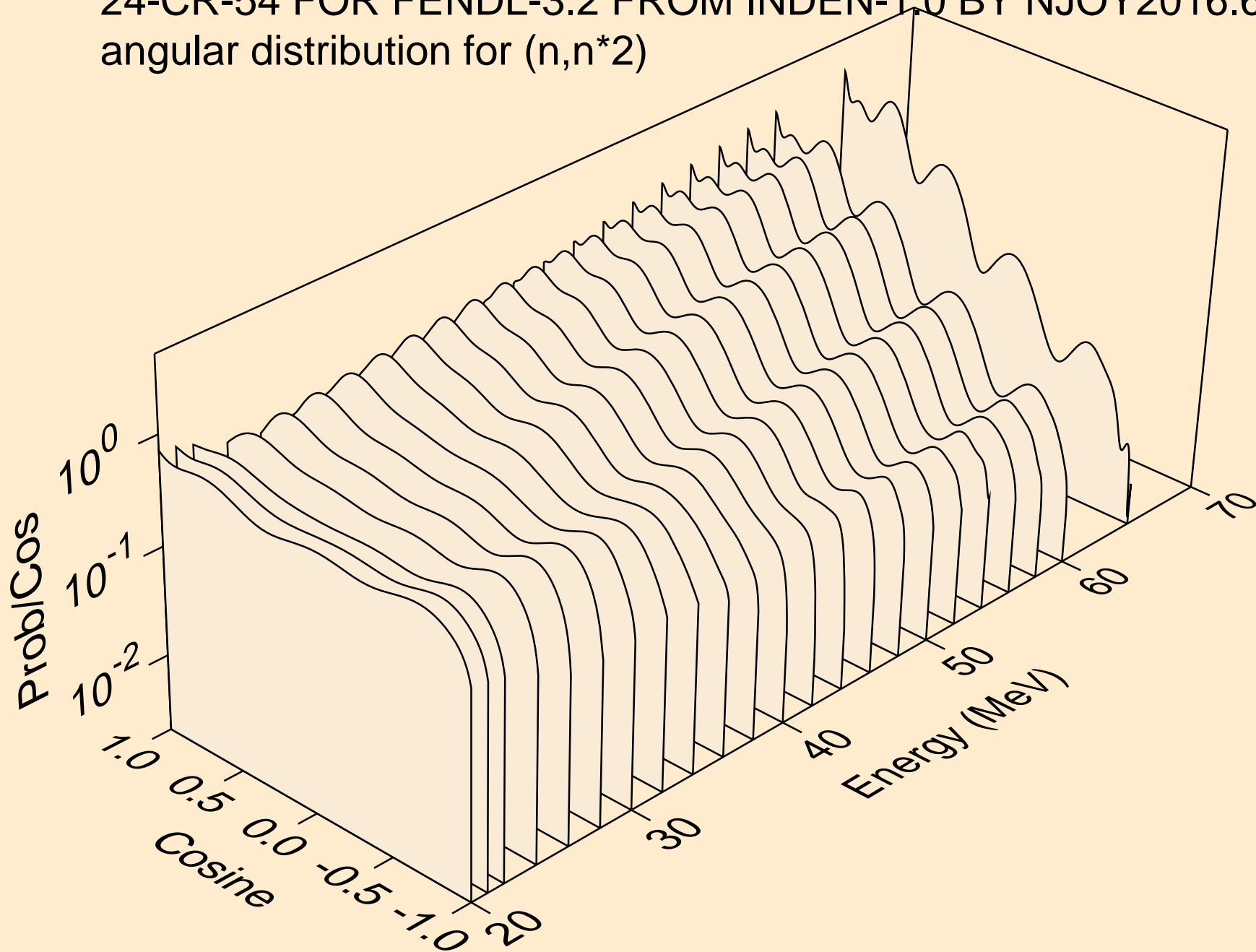

24-CR-54 FOR FENDL-3.2 FROM INDEN-1.0 BY NJOY2016.60+ OI
angular distribution for (n,n*3)

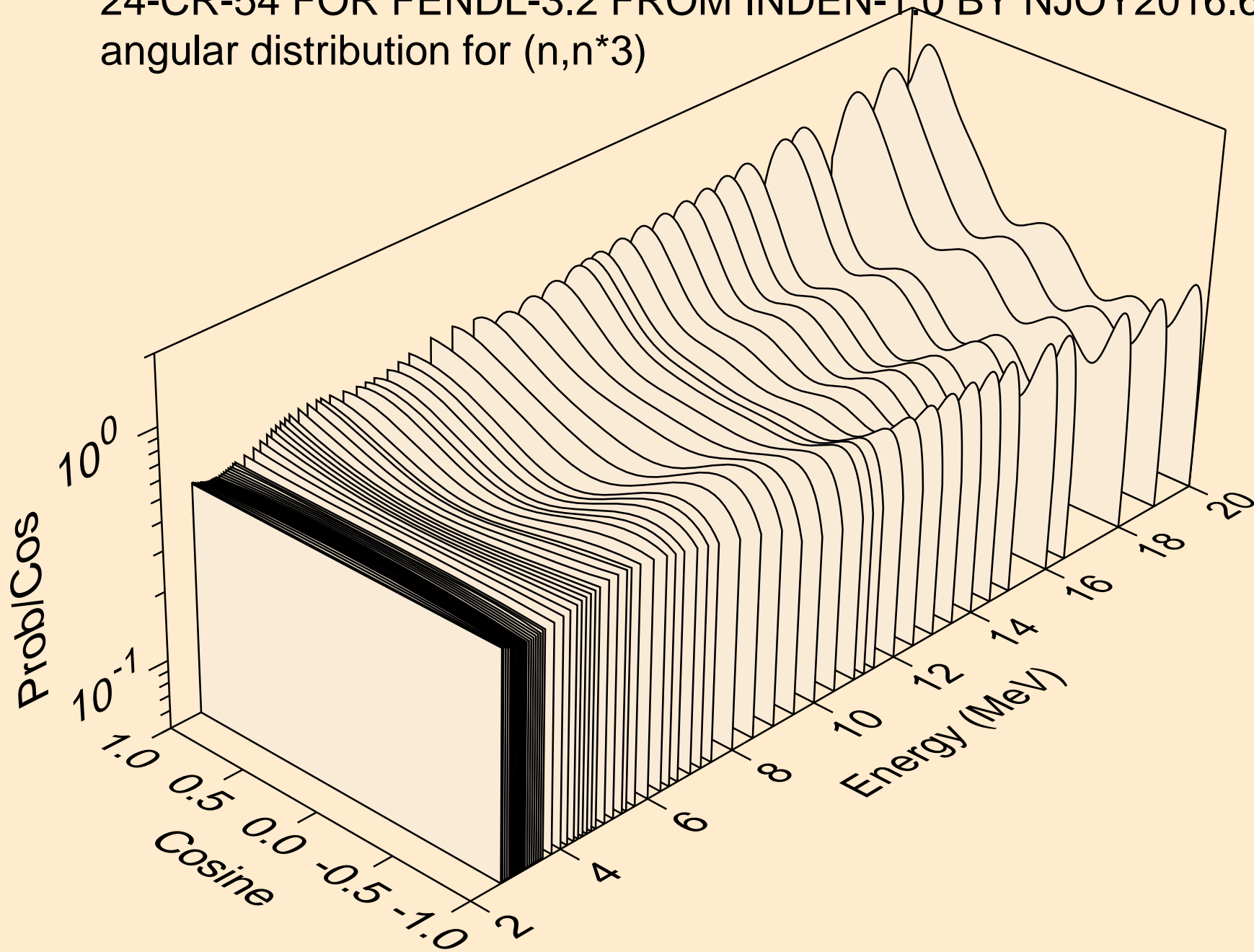

24-CR-54 FOR FENDL-3.2 FROM INDEN-1.0 BY NJOY2016.60+ OI
angular distribution for (n,n*3)

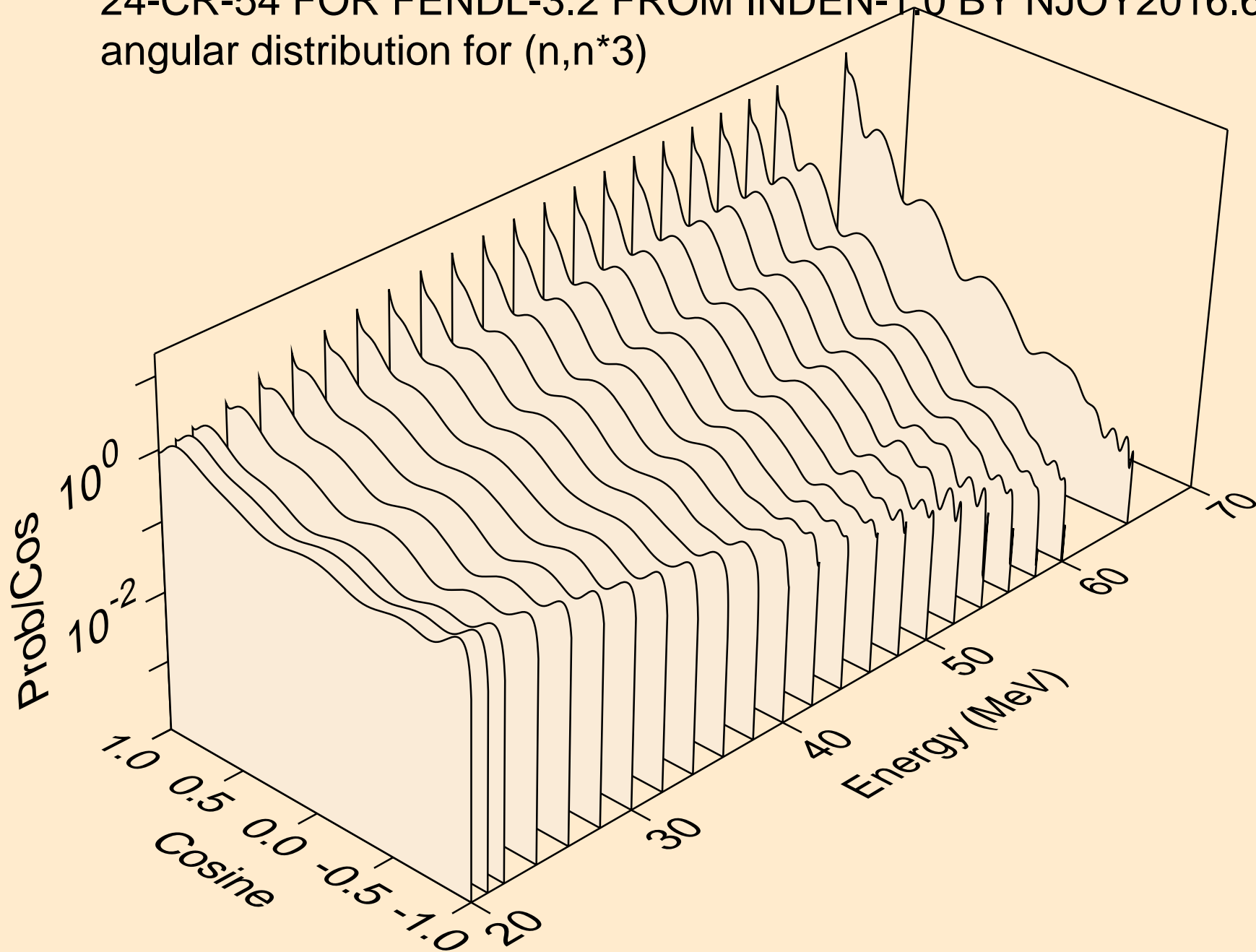

24-CR-54 FOR FENDL-3.2 FROM INDEN-1.0 BY NJOY2016.60+ OI
angular distribution for (n,n*4)

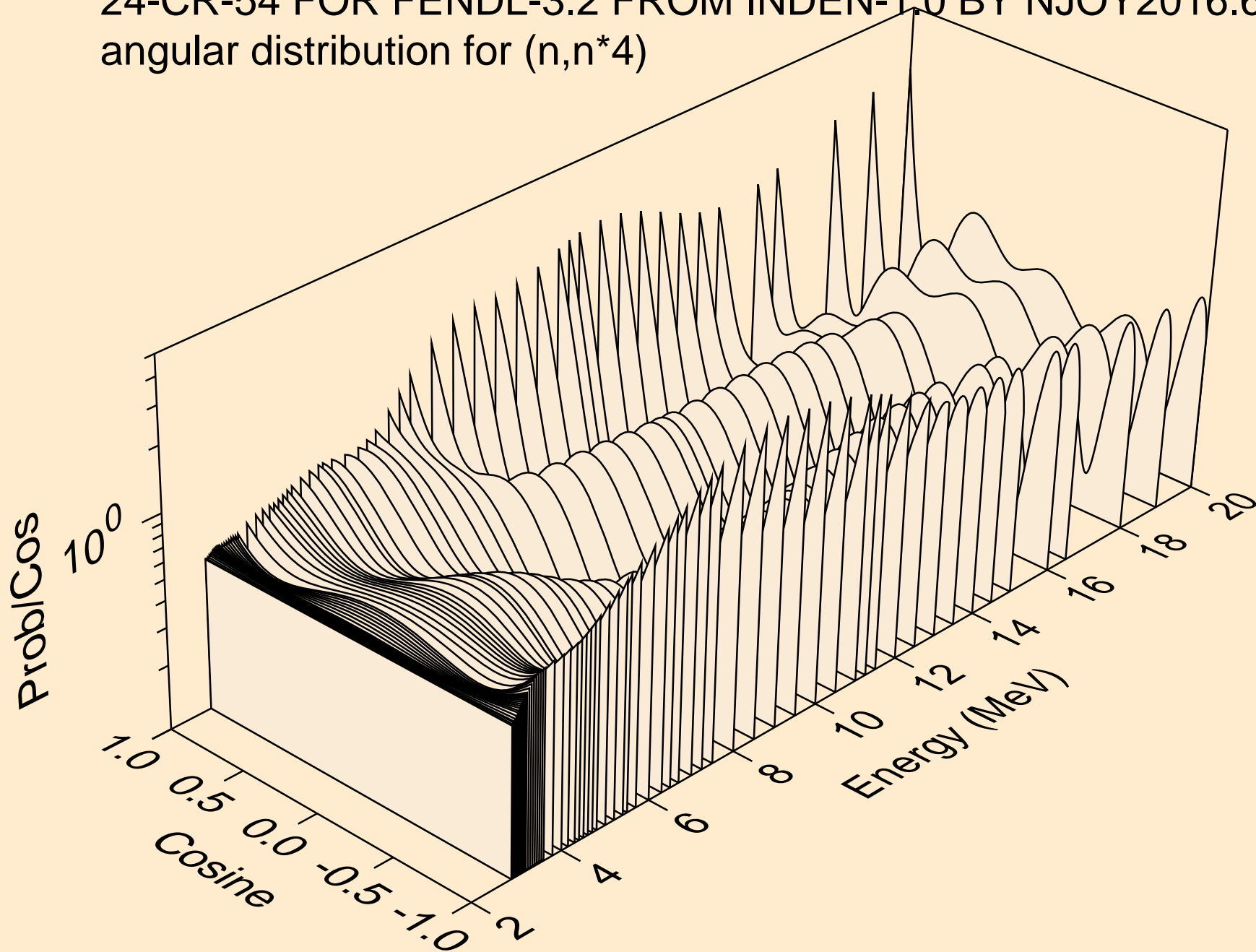

24-CR-54 FOR FENDL-3.2 FROM INDEN-1.0 BY NJOY2016.60+ OI
angular distribution for (n,n*4)

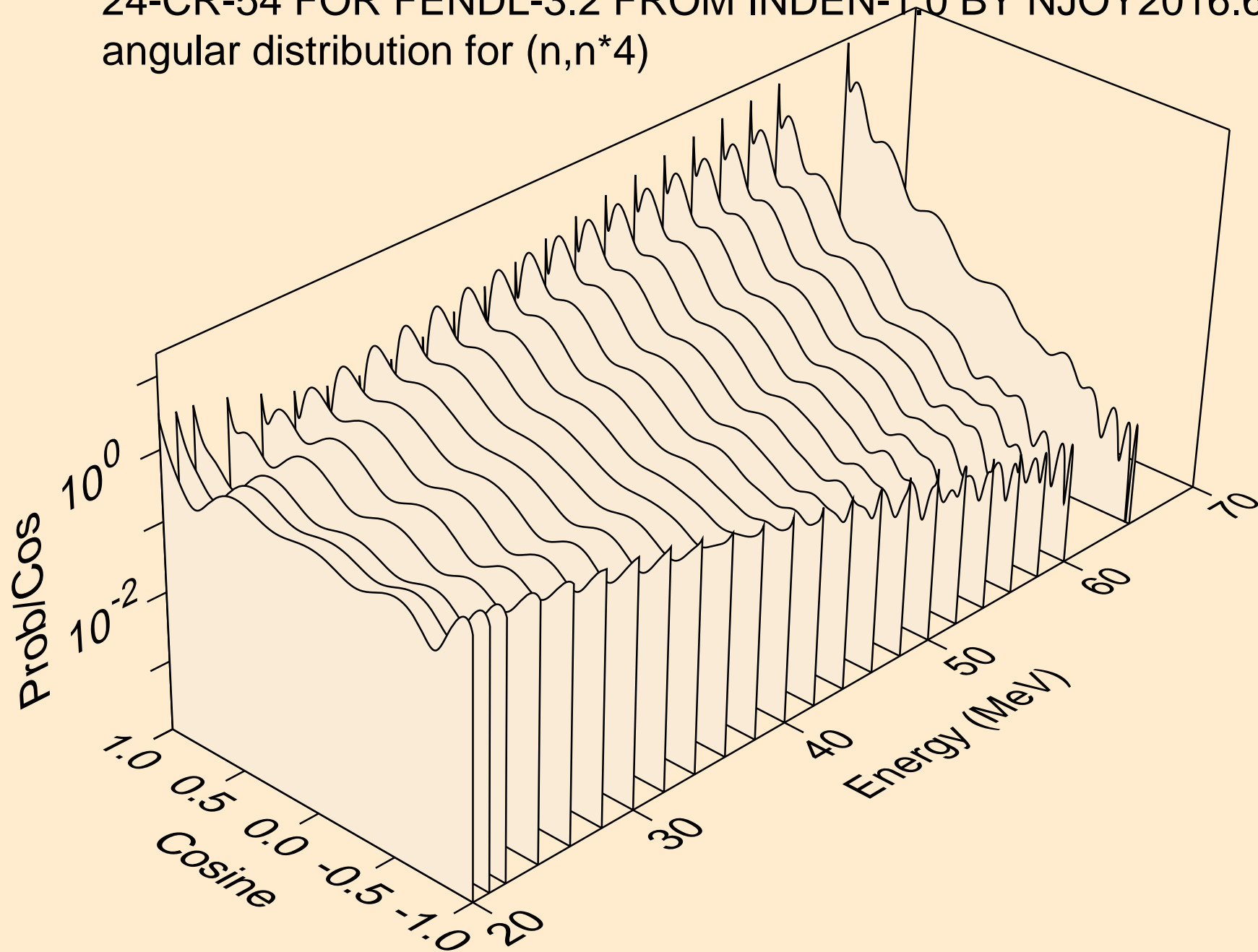

24-CR-54 FOR FENDL-3.2 FROM INDEN-1.0 BY NJOY2016.60+ OI
angular distribution for (n,n*5)

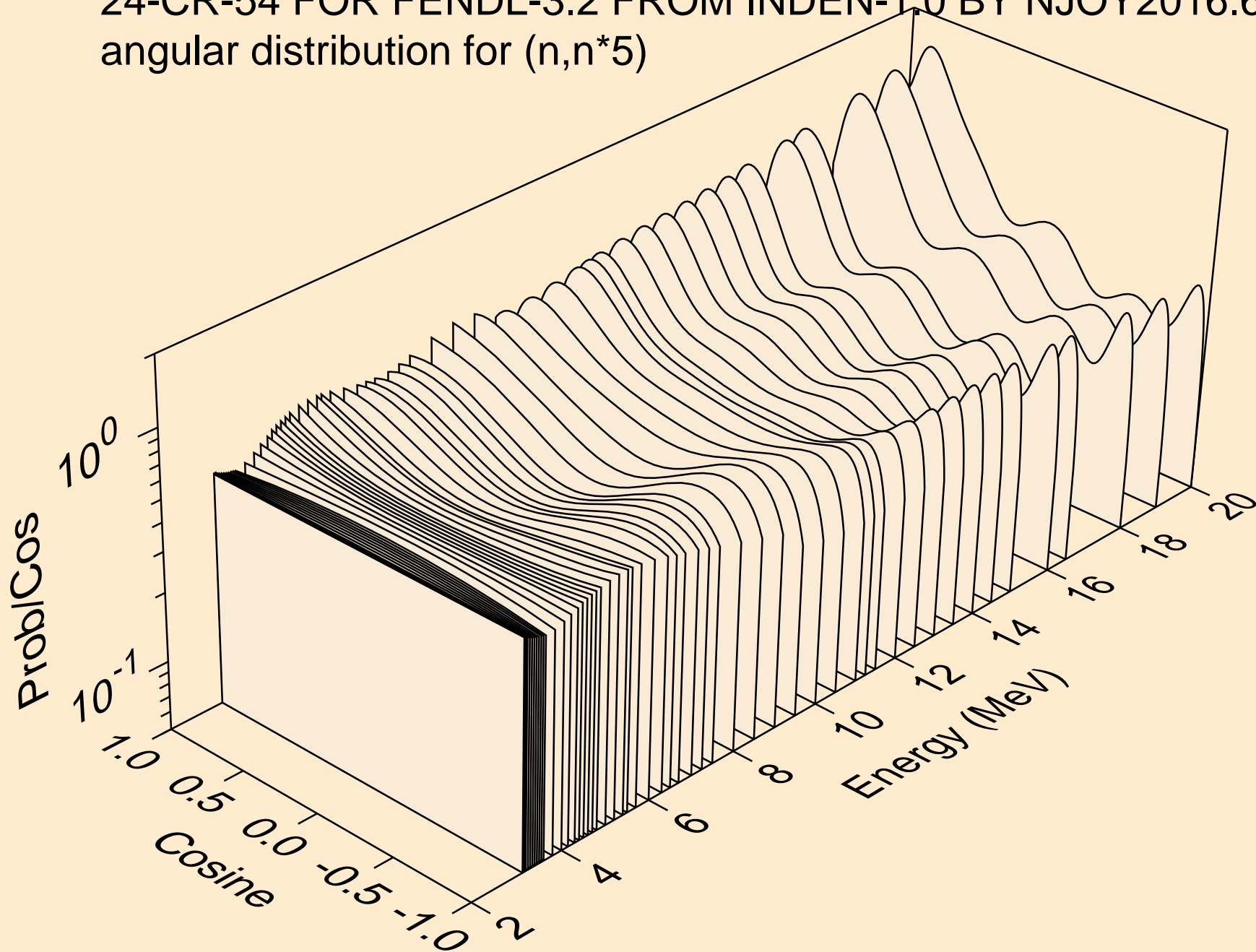

24-CR-54 FOR FENDL-3.2 FROM INDEN-1.0 BY NJOY2016.60+ OI
angular distribution for (n,n*5)

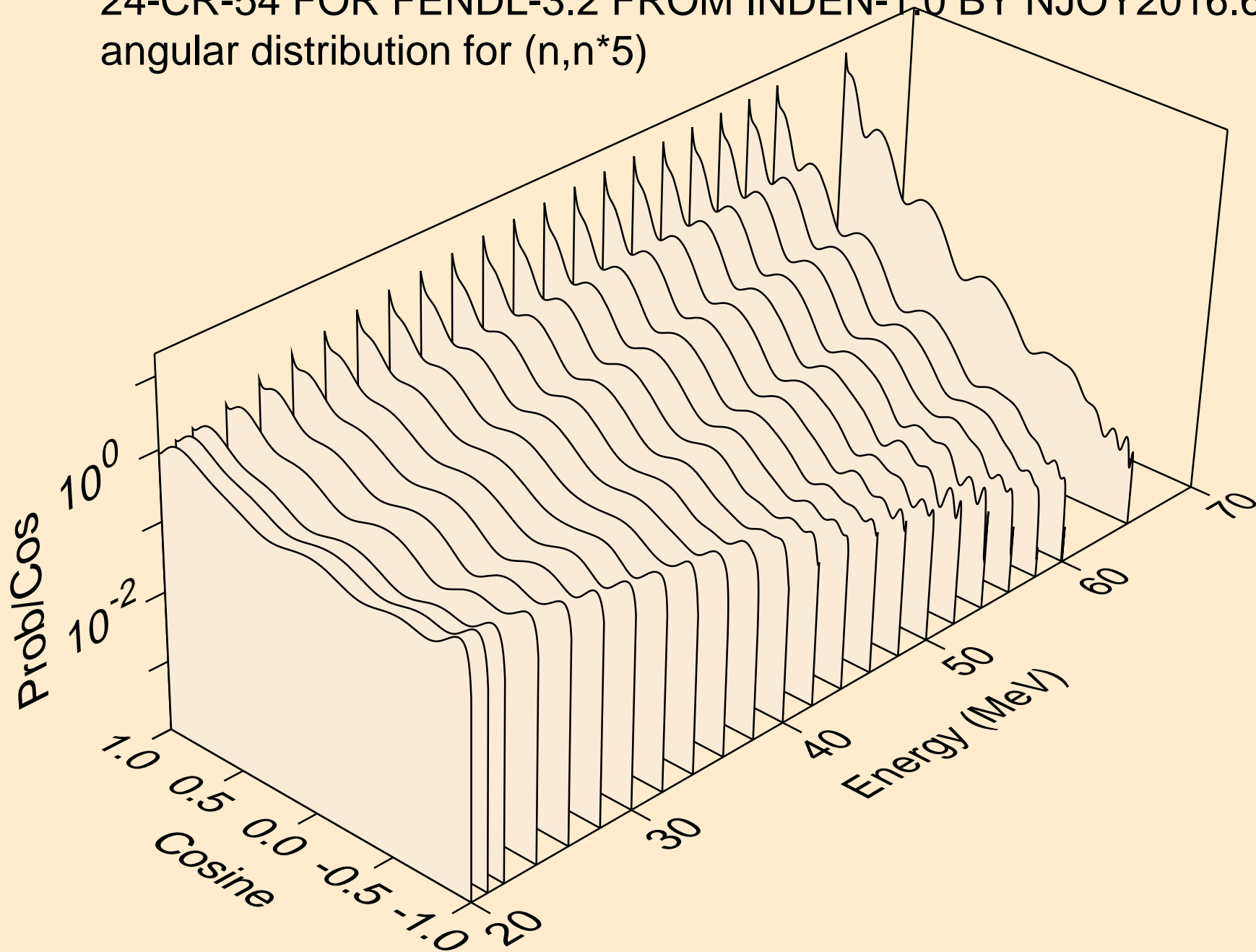

24-CR-54 FOR FENDL-3.2 FROM INDEN-1.0 BY NJOY2016.60+ OI
angular distribution for (n,n*6)

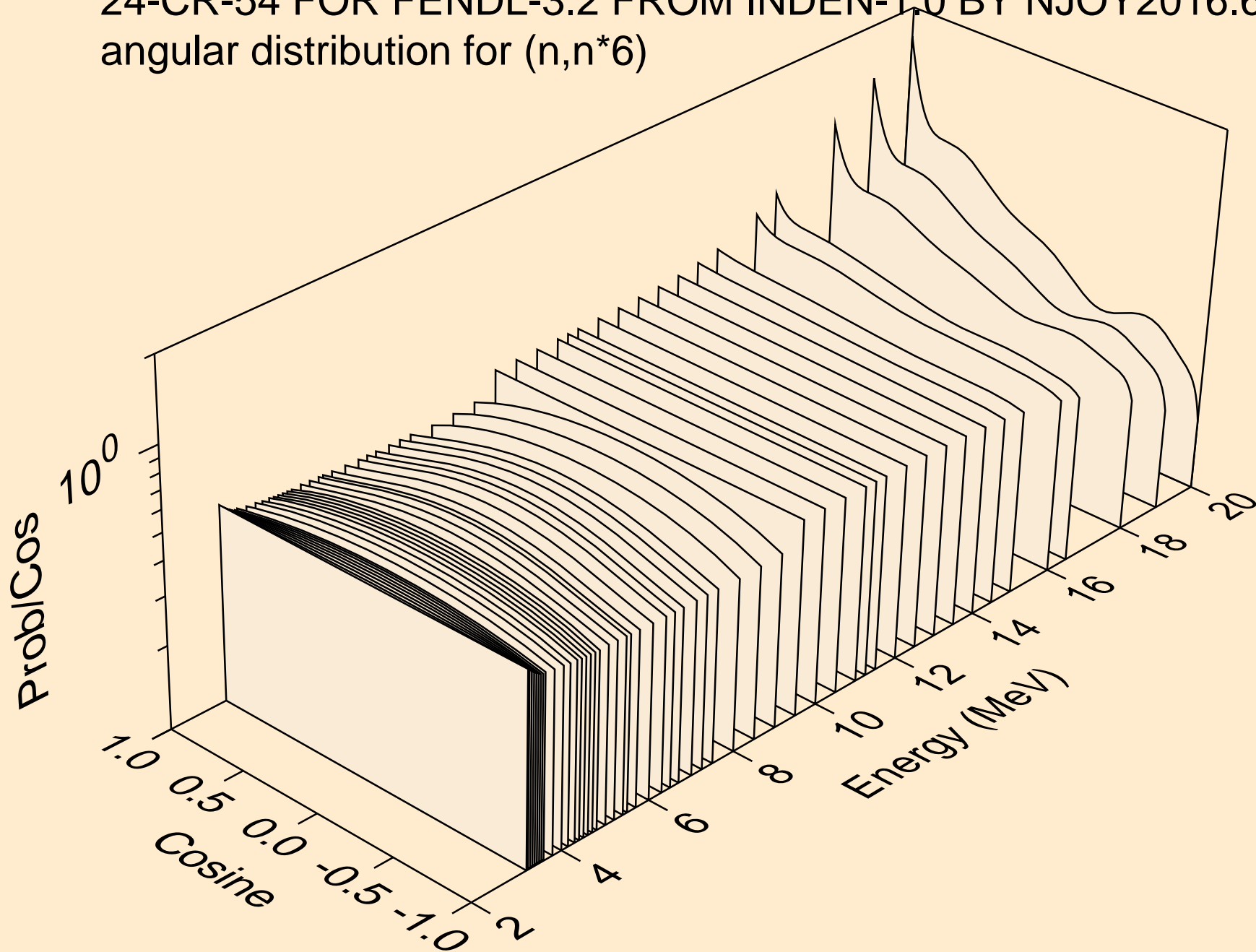

24-CR-54 FOR FENDL-3.2 FROM INDEN-1.0 BY NJOY2016.60+ OI
angular distribution for (n,n*6)

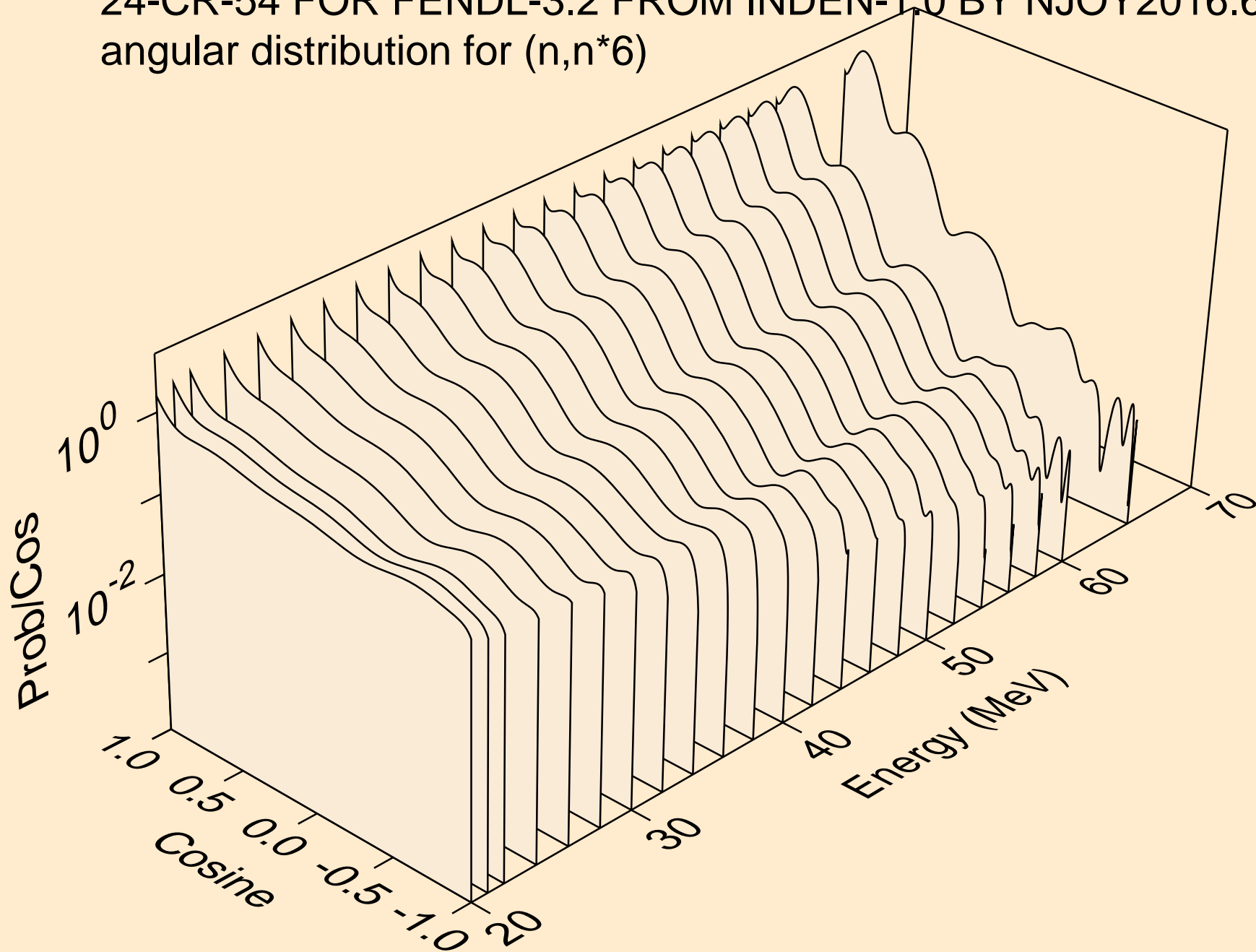

24-CR-54 FOR FENDL-3.2 FROM INDEN-1.0 BY NJOY2016.60+ OI
angular distribution for (n,n*7)

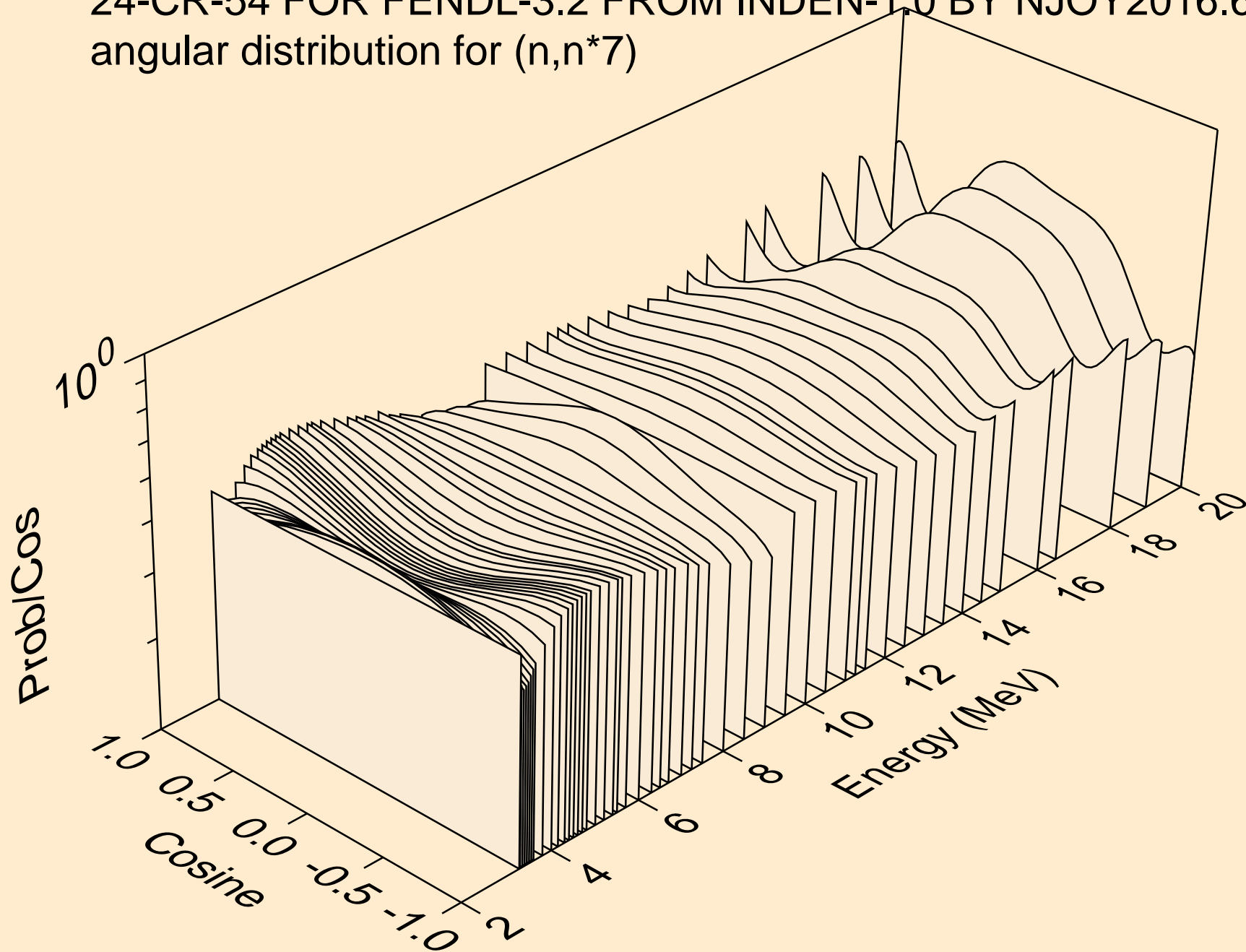

24-CR-54 FOR FENDL-3.2 FROM INDEN-1.0 BY NJOY2016.60+ OI
angular distribution for (n,n*7)

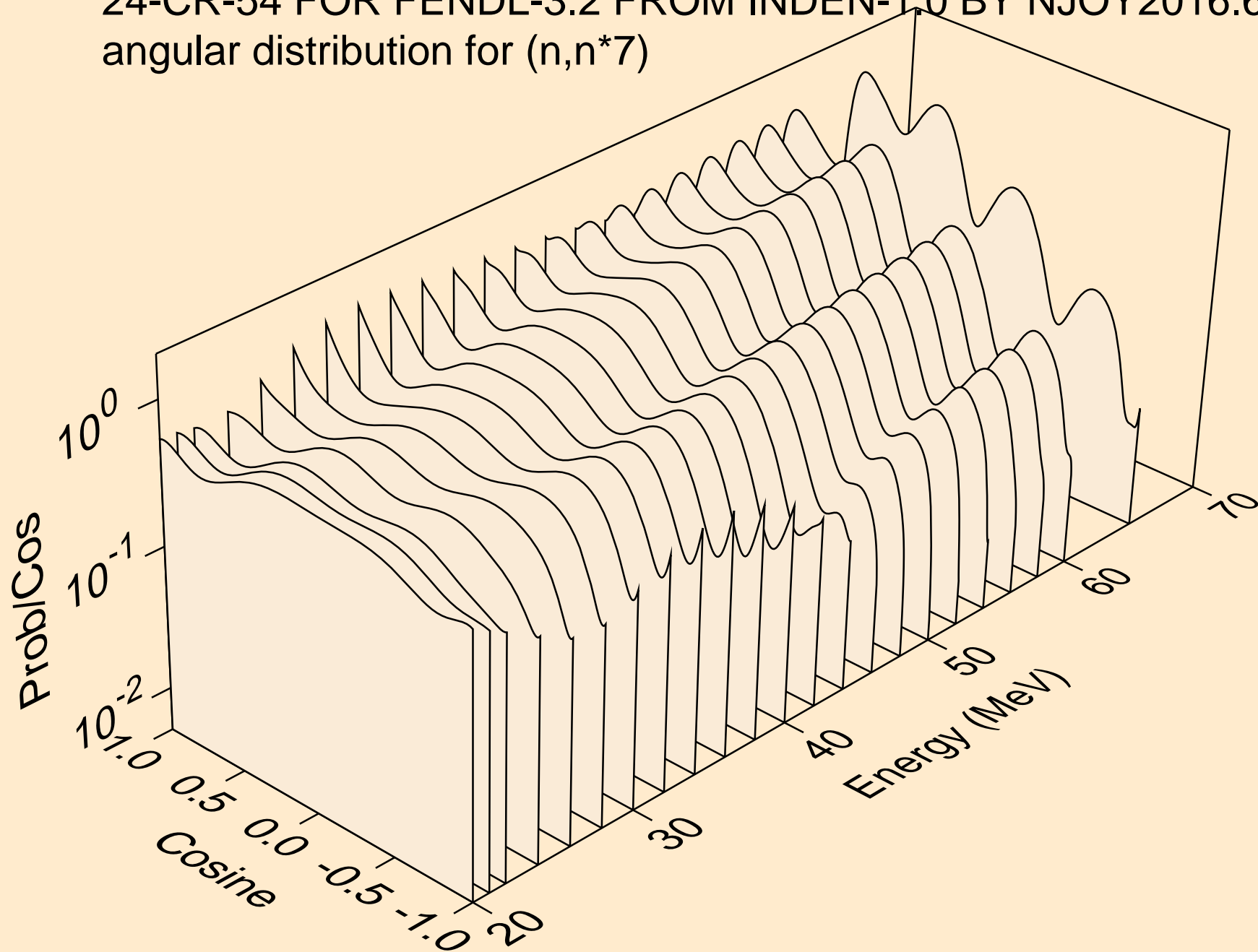

24-CR-54 FOR FENDL-3.2 FROM INDEN-1.0 BY NJOY2016.60+ OI
angular distribution for (n,n*8)

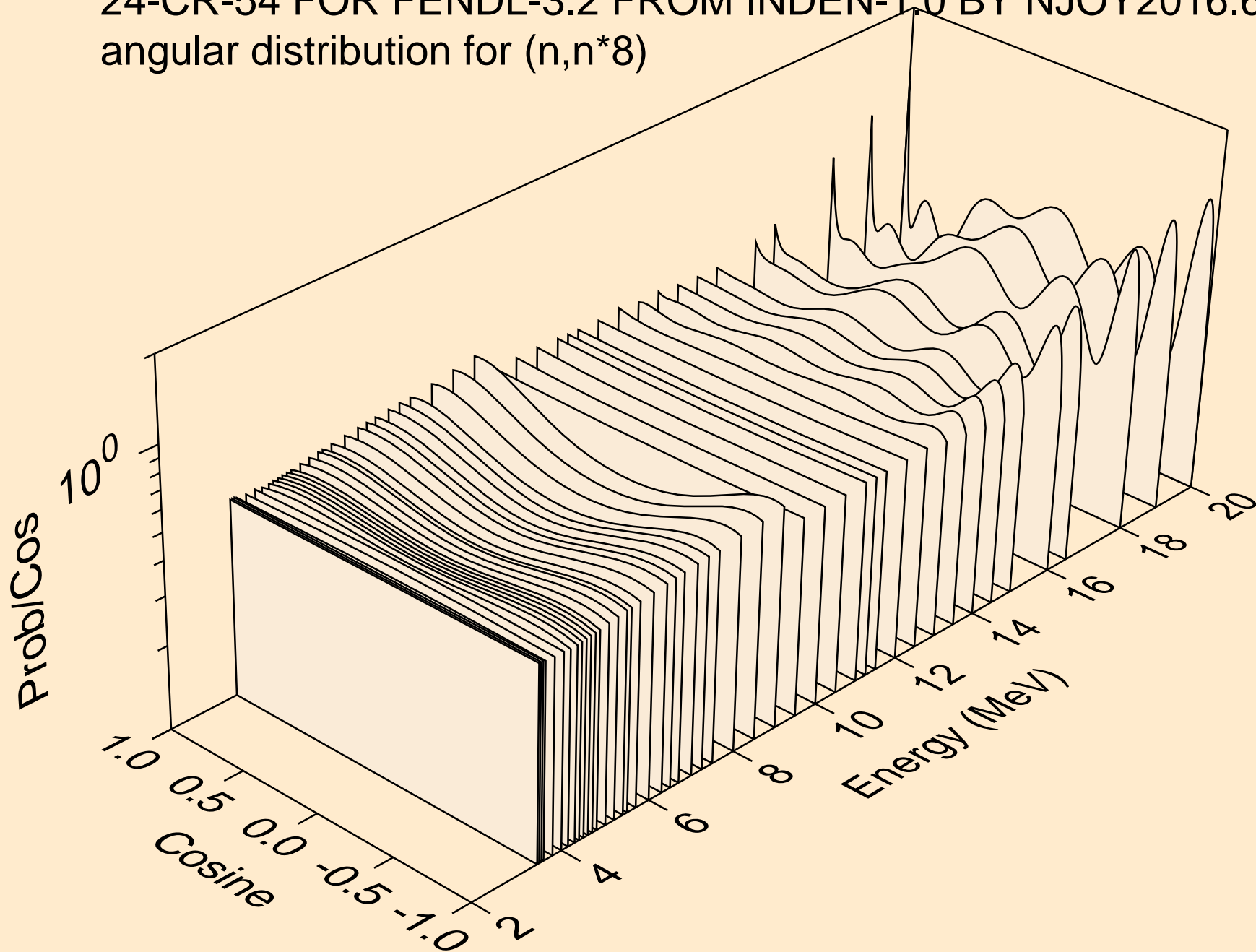

24-CR-54 FOR FENDL-3.2 FROM INDEN-1.0 BY NJOY2016.60+ OI
angular distribution for (n,n*8)

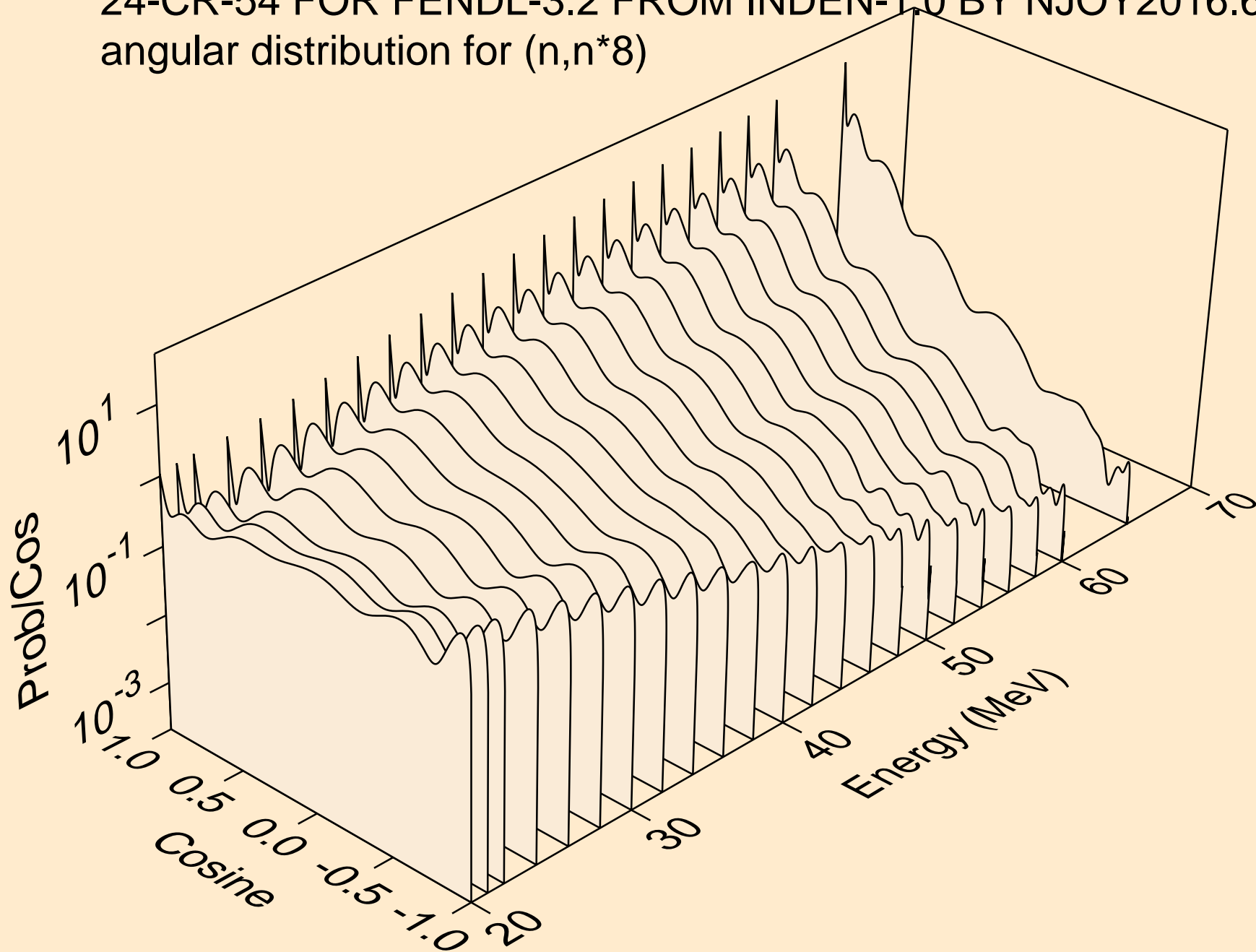

24-CR-54 FOR FENDL-3.2 FROM INDEN-1.0 BY NJOY2016.60+ OI
angular distribution for (n,n*9)

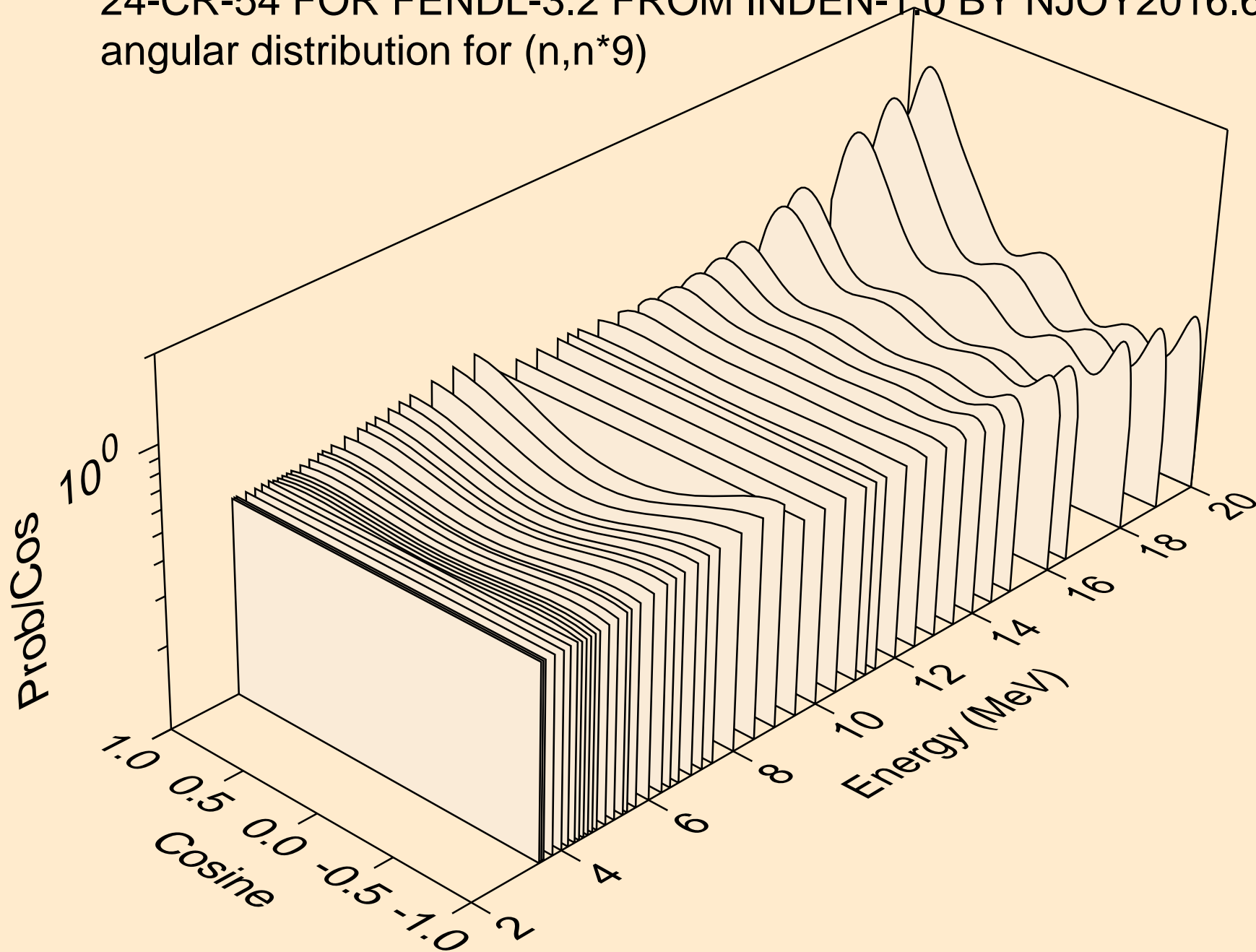

24-CR-54 FOR FENDL-3.2 FROM INDEN-1.0 BY NJOY2016.60+ OI
angular distribution for (n,n*9)

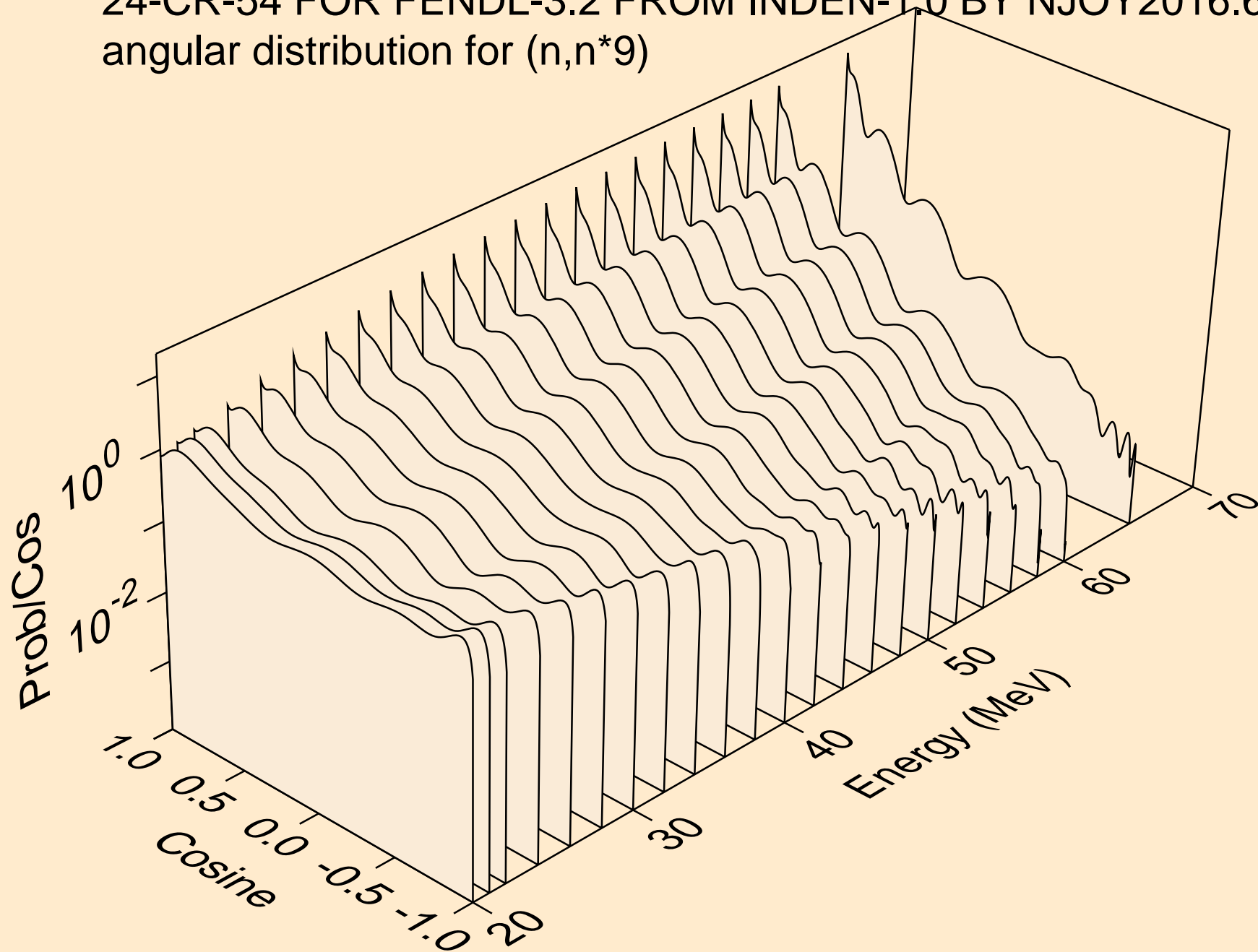

24-CR-54 FOR FENDL-3.2 FROM INDEN-1.0 BY NJOY2016.60+ OI
angular distribution for (n,n*10)

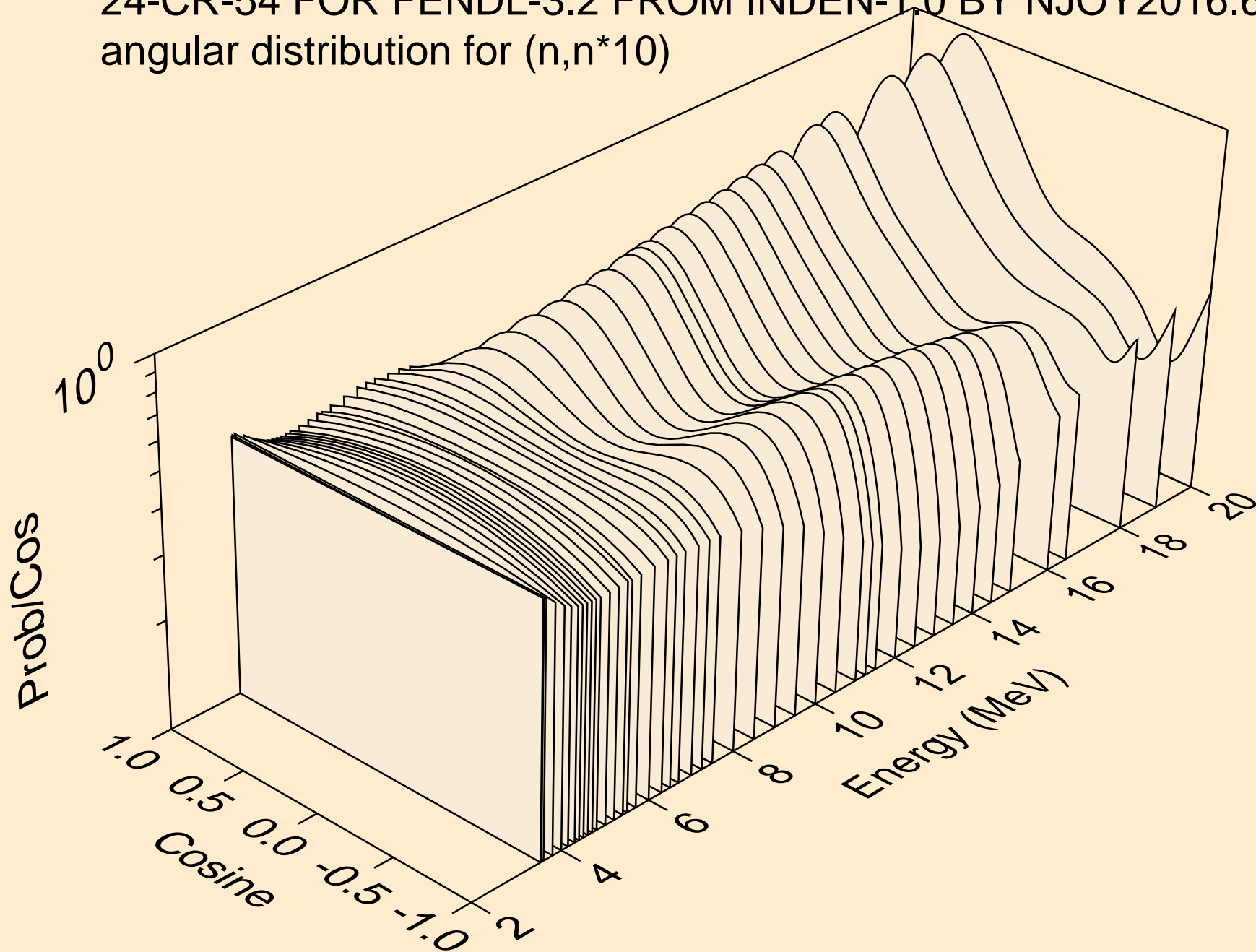

24-CR-54 FOR FENDL-3.2 FROM INDEN-1.0 BY NJOY2016.60+ OI
angular distribution for (n,n*10)

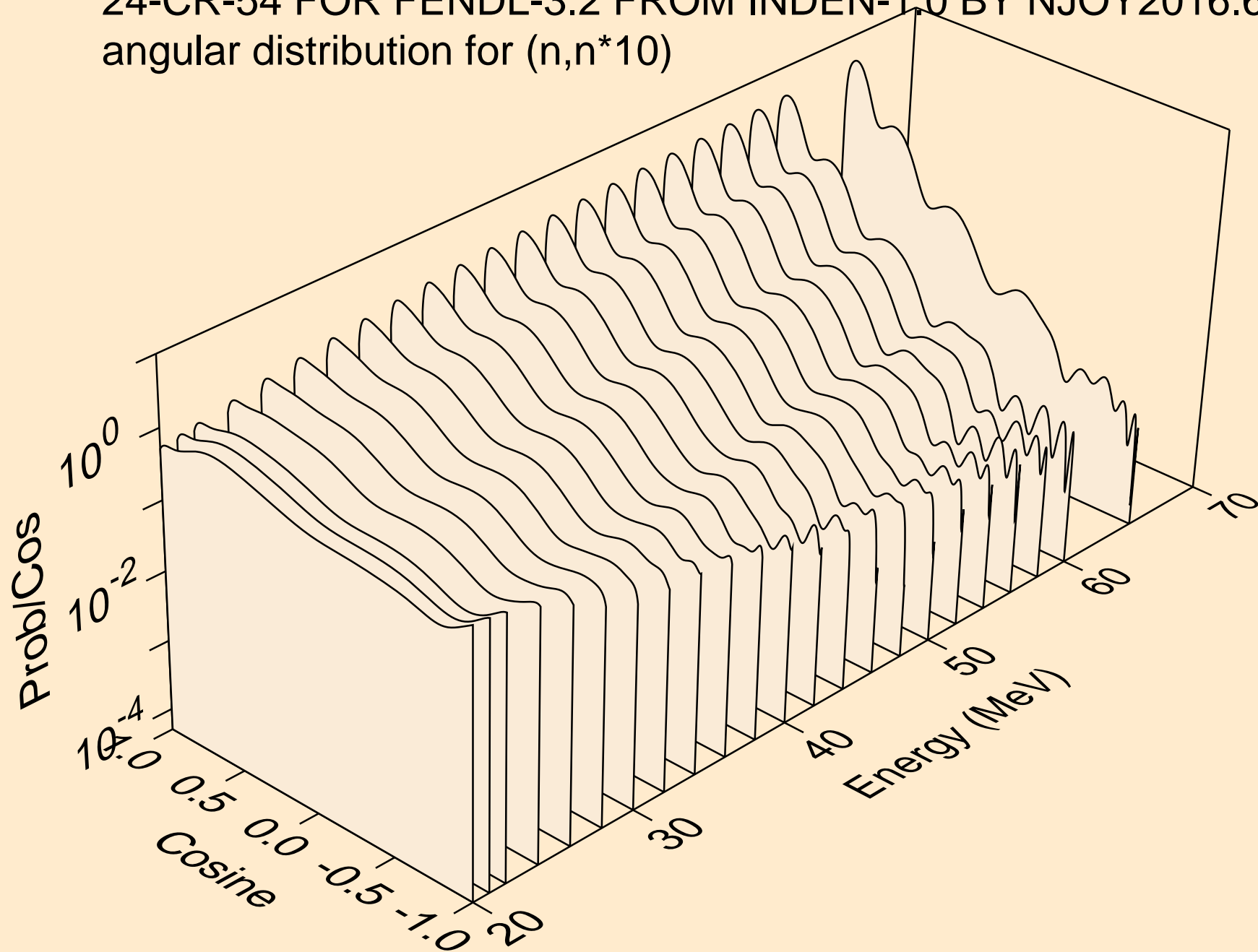

24-CR-54 FOR FENDL-3.2 FROM INDEN-1.0 BY NJOY2016.60+ OI
angular distribution for (n,n*11)

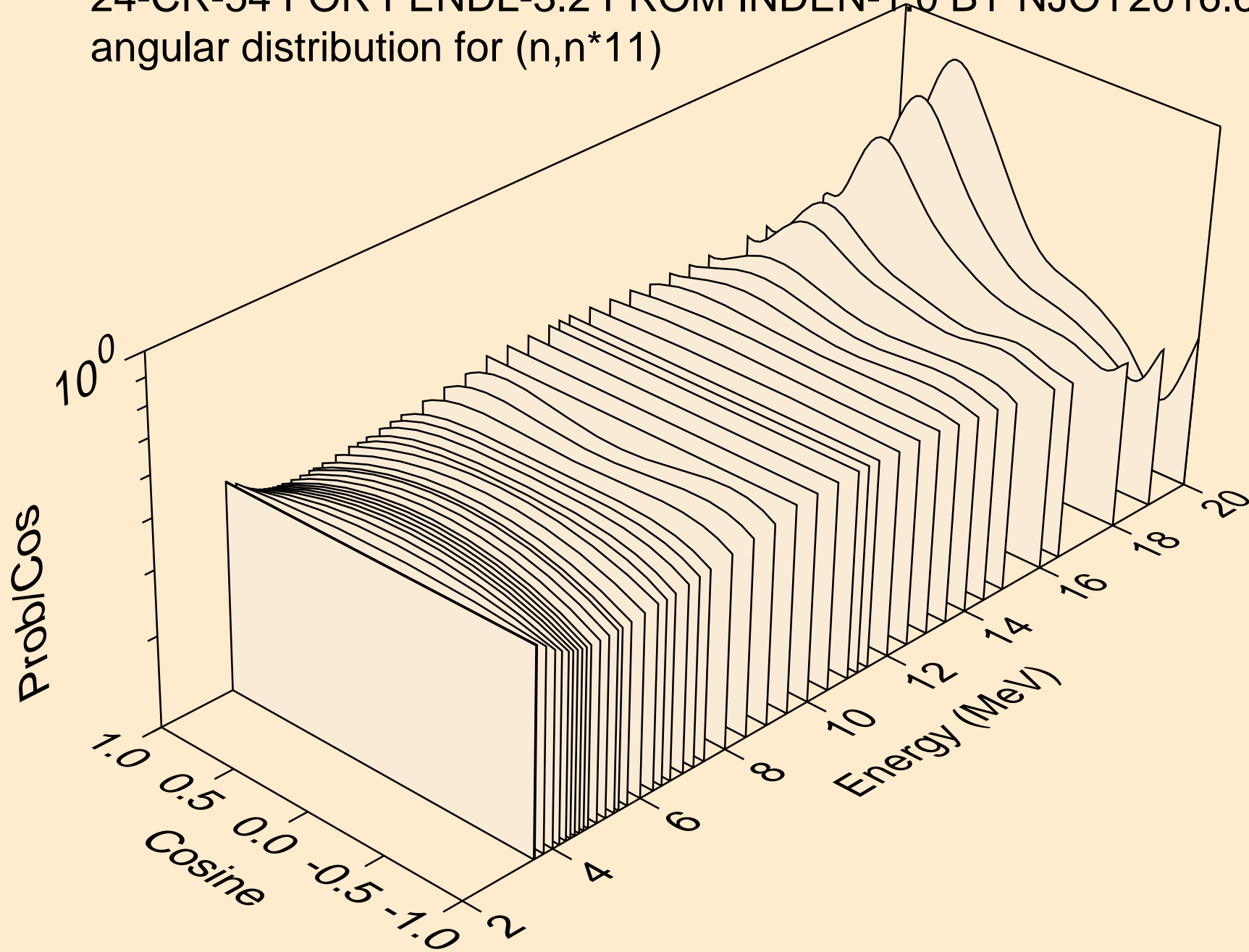

24-CR-54 FOR FENDL-3.2 FROM INDEN-1.0 BY NJOY2016.60+ OI
angular distribution for (n,n*11)

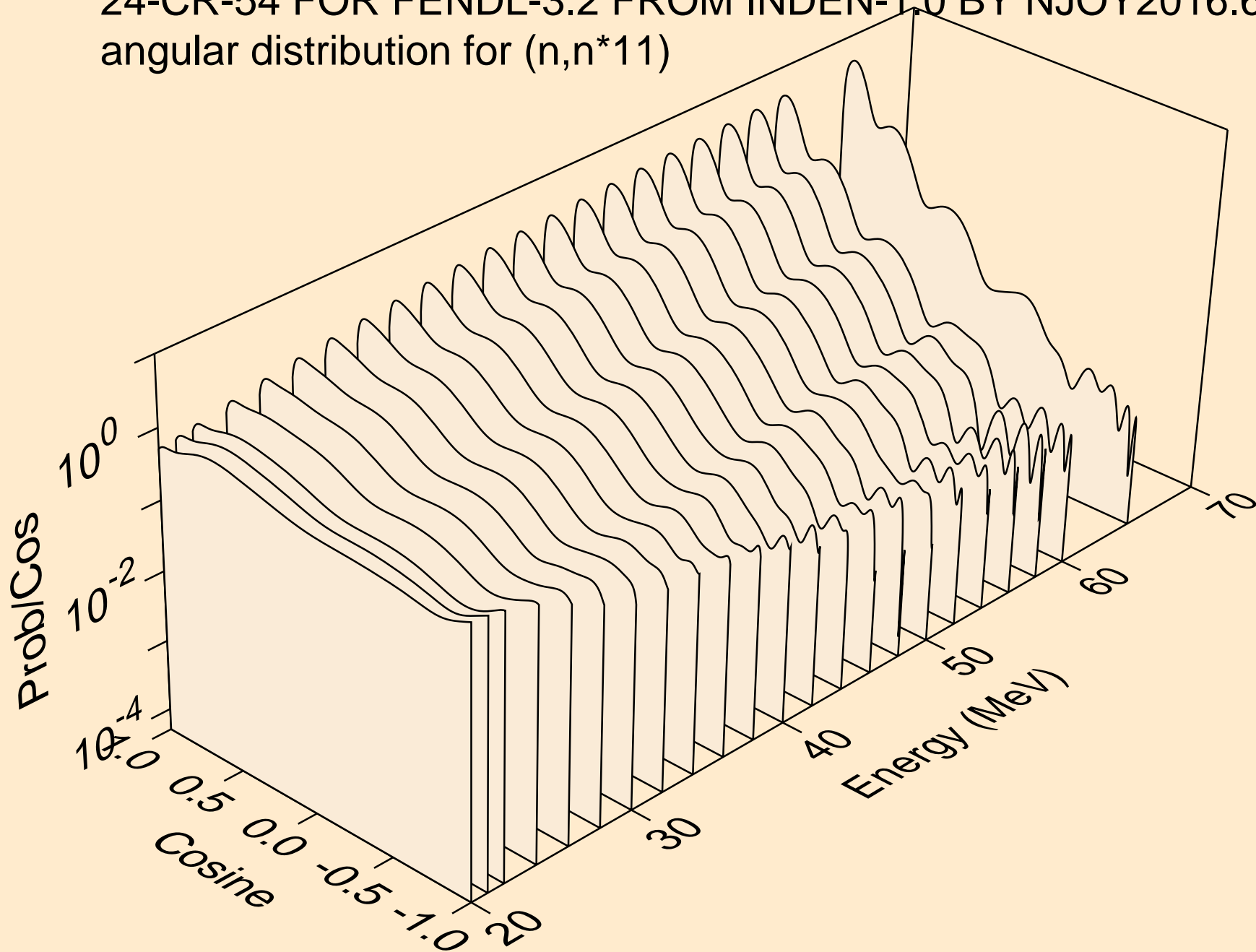

24-CR-54 FOR FENDL-3.2 FROM INDEN-1.0 BY NJOY2016.60+ OI
angular distribution for (n,n*12)

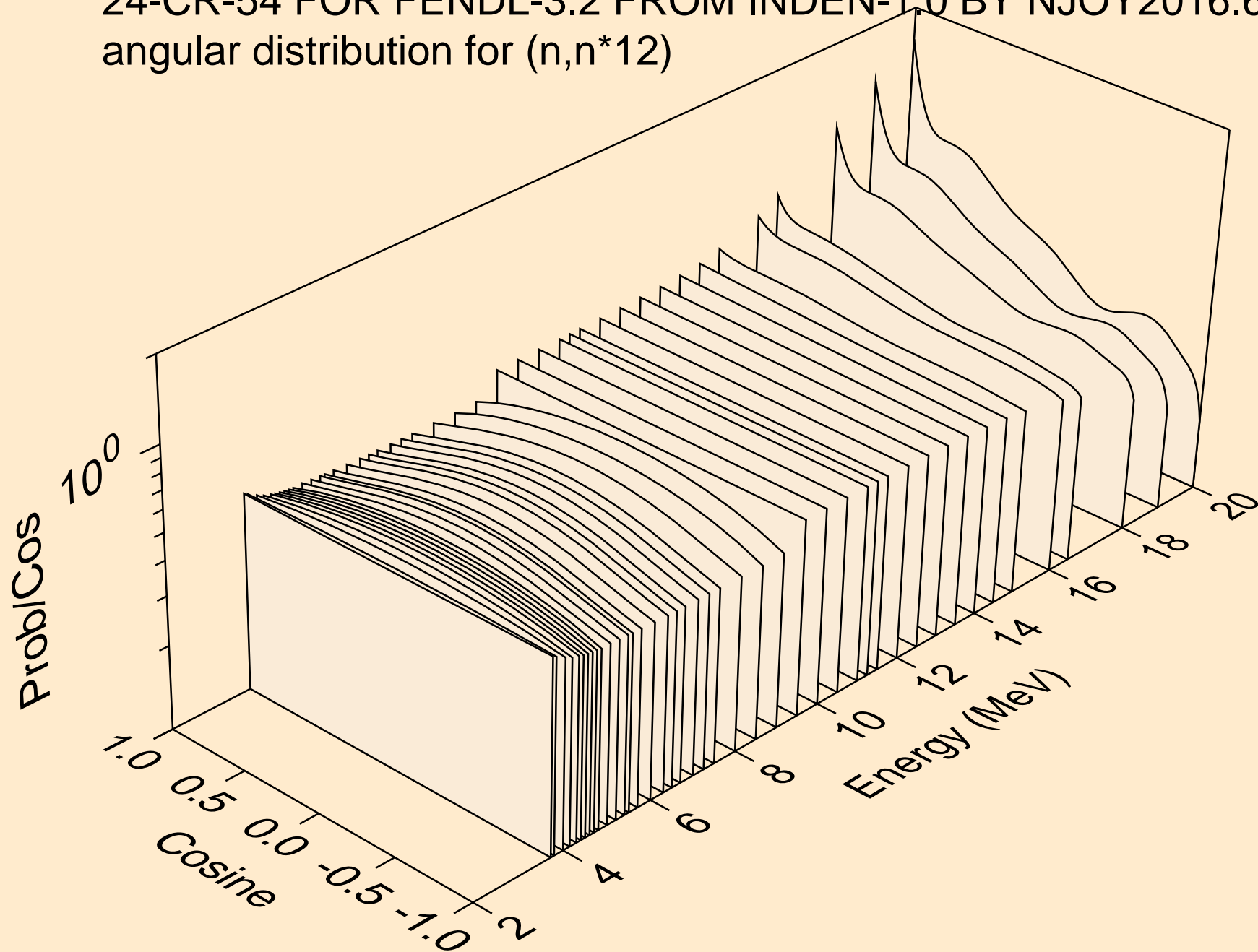

24-CR-54 FOR FENDL-3.2 FROM INDEN-1.0 BY NJOY2016.60+ OI
angular distribution for (n,n*12)

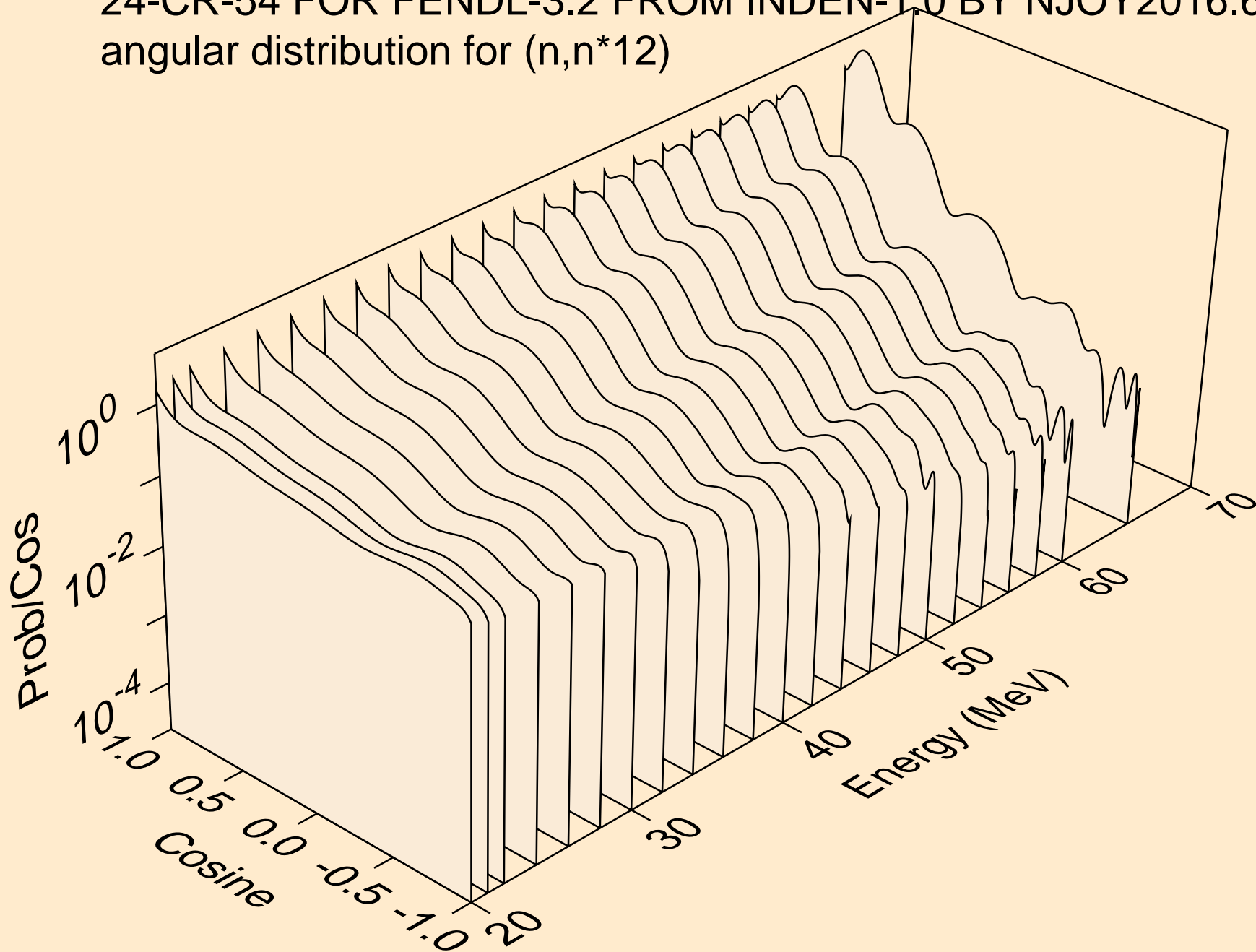

24-CR-54 FOR FENDL-3.2 FROM INDEN-1.0 BY NJOY2016.60+ OI
angular distribution for (n,n*13)

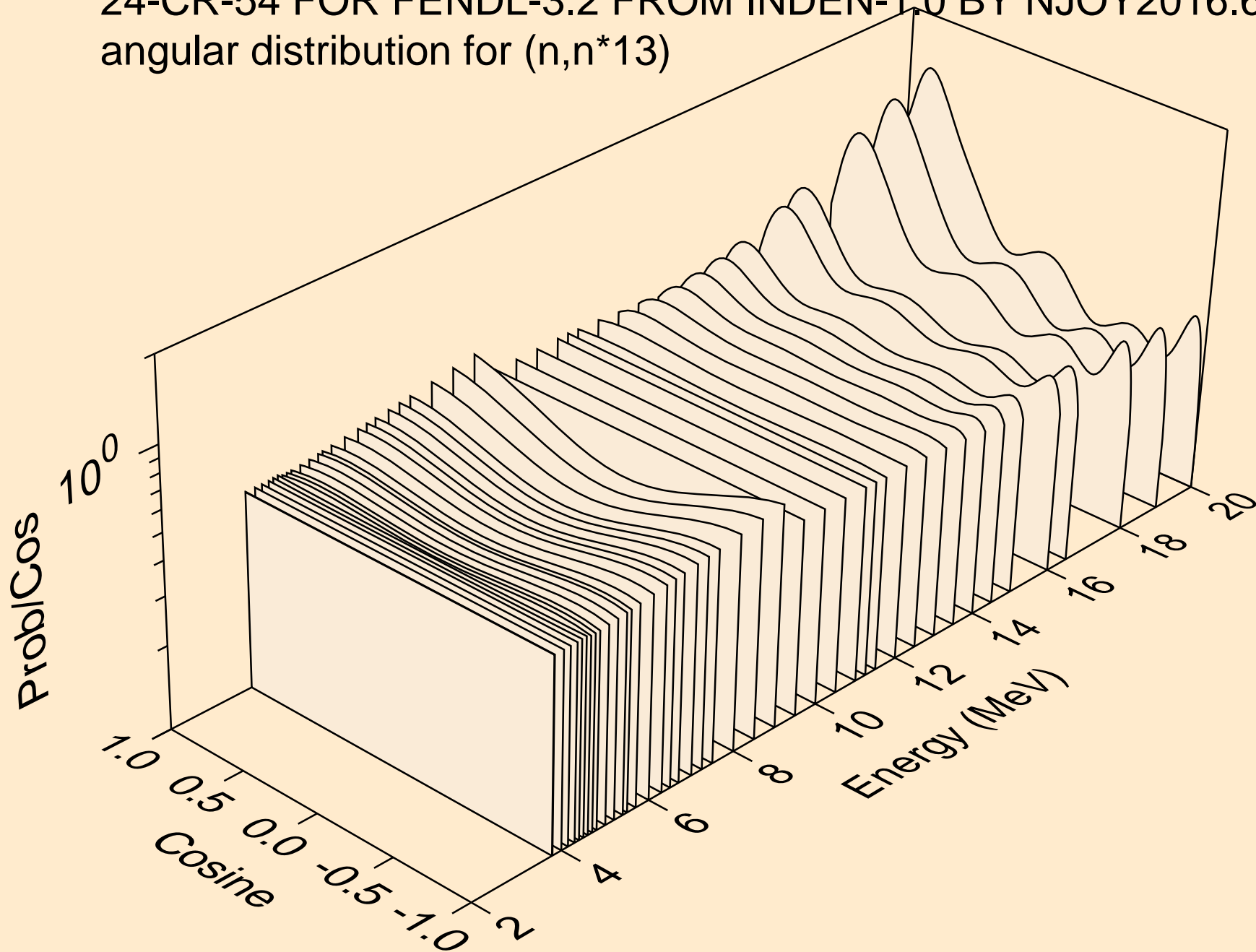

24-CR-54 FOR FENDL-3.2 FROM INDEN-1.0 BY NJOY2016.60+ OI
angular distribution for (n,n*13)

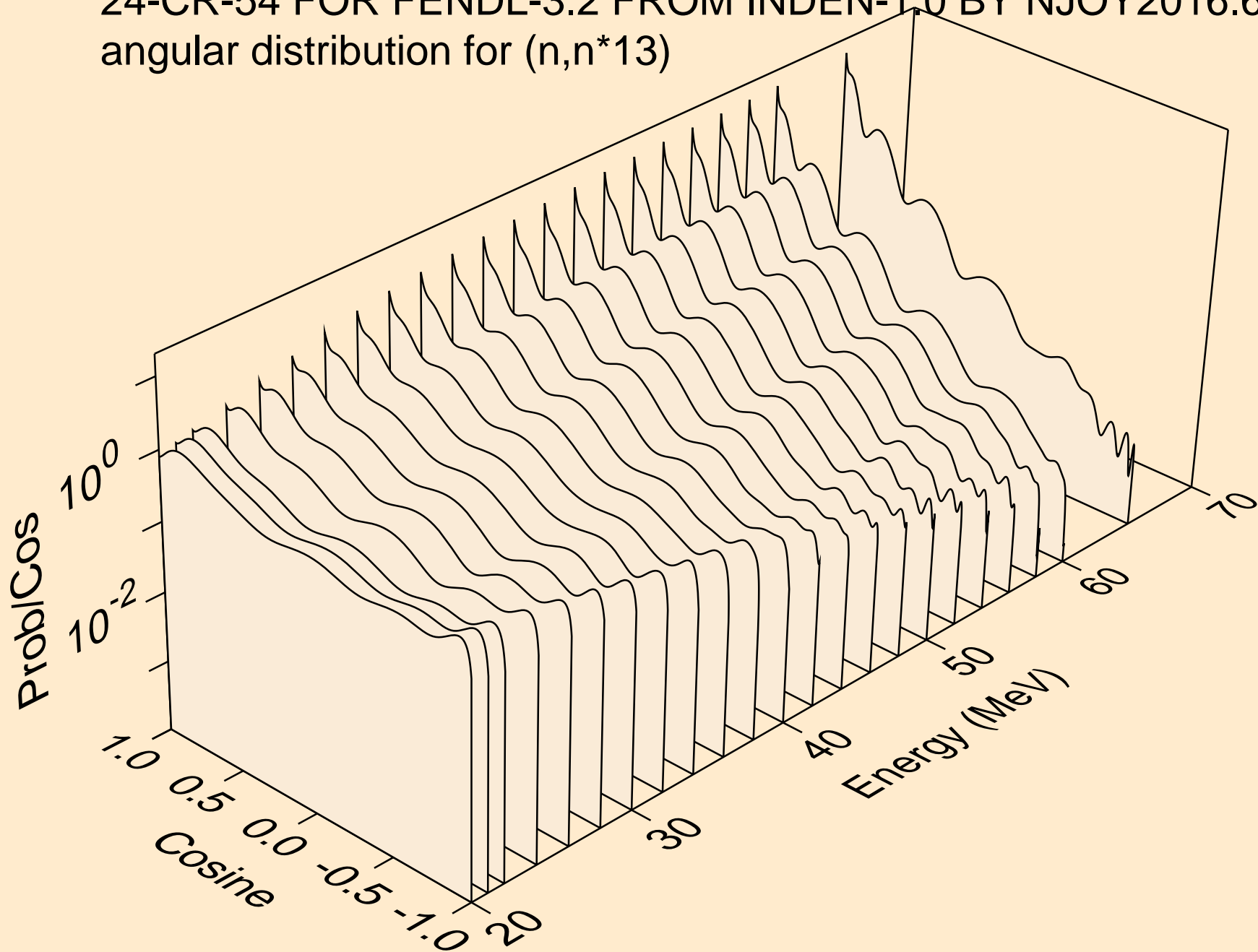

24-CR-54 FOR FENDL-3.2 FROM INDEN-1.0 BY NJOY2016.60+ OI
angular distribution for (n,n*14)

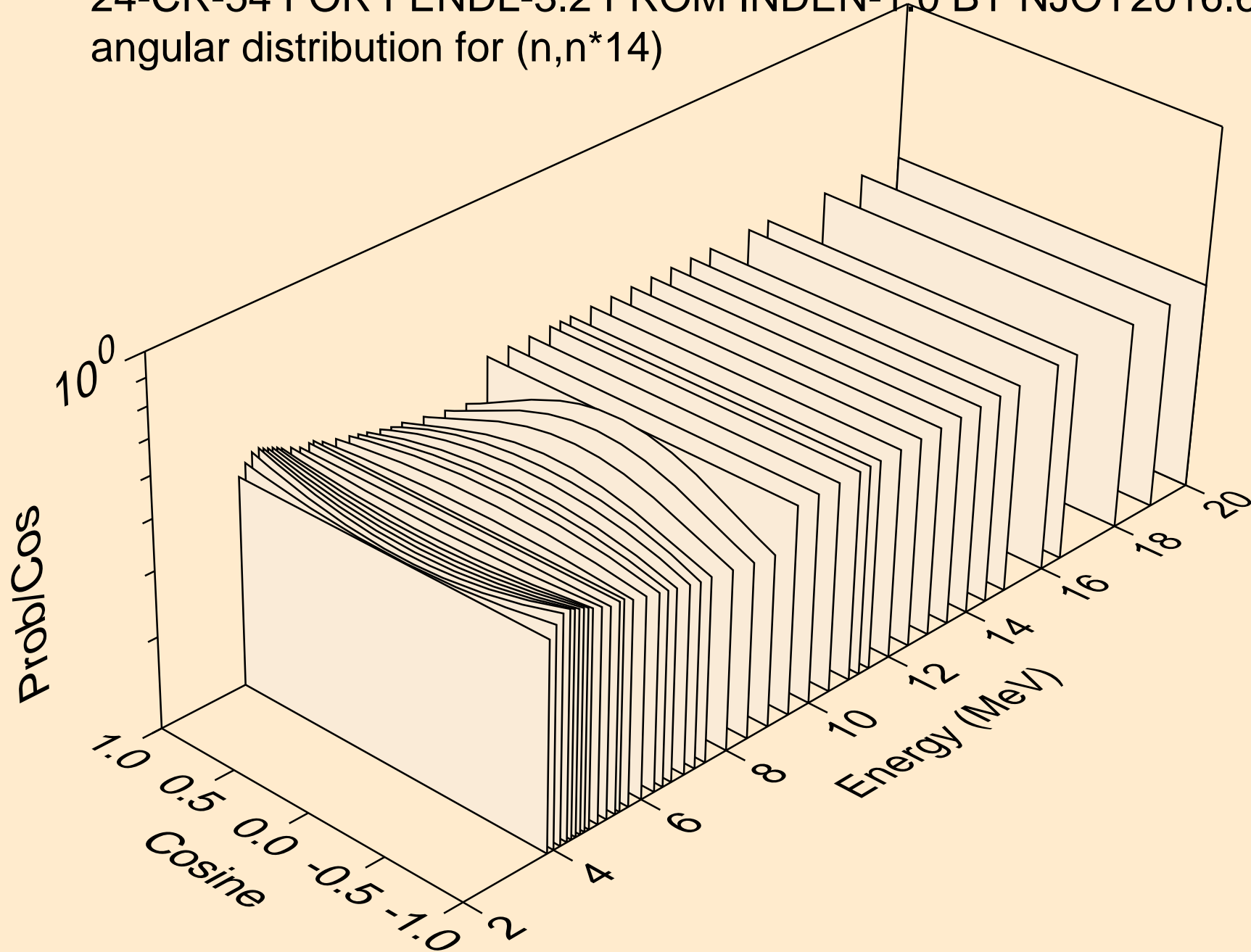

24-CR-54 FOR FENDL-3.2 FROM INDEN-1.0 BY NJOY2016.60+ OI
angular distribution for (n,n*14)

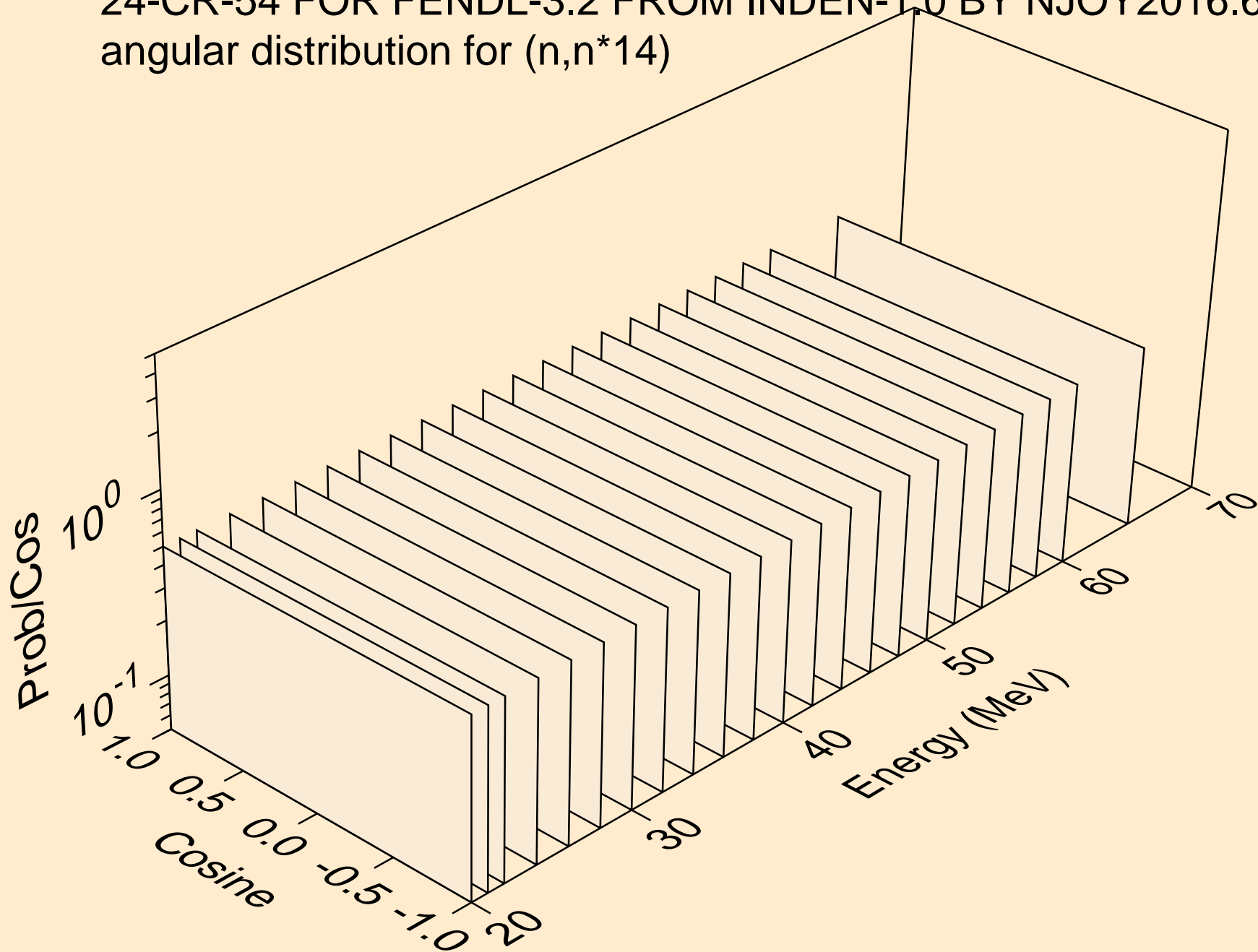

24-CR-54 FOR FENDL-3.2 FROM INDEN-1.0 BY NJOY2016.60+ OI
angular distribution for (n,n*15)

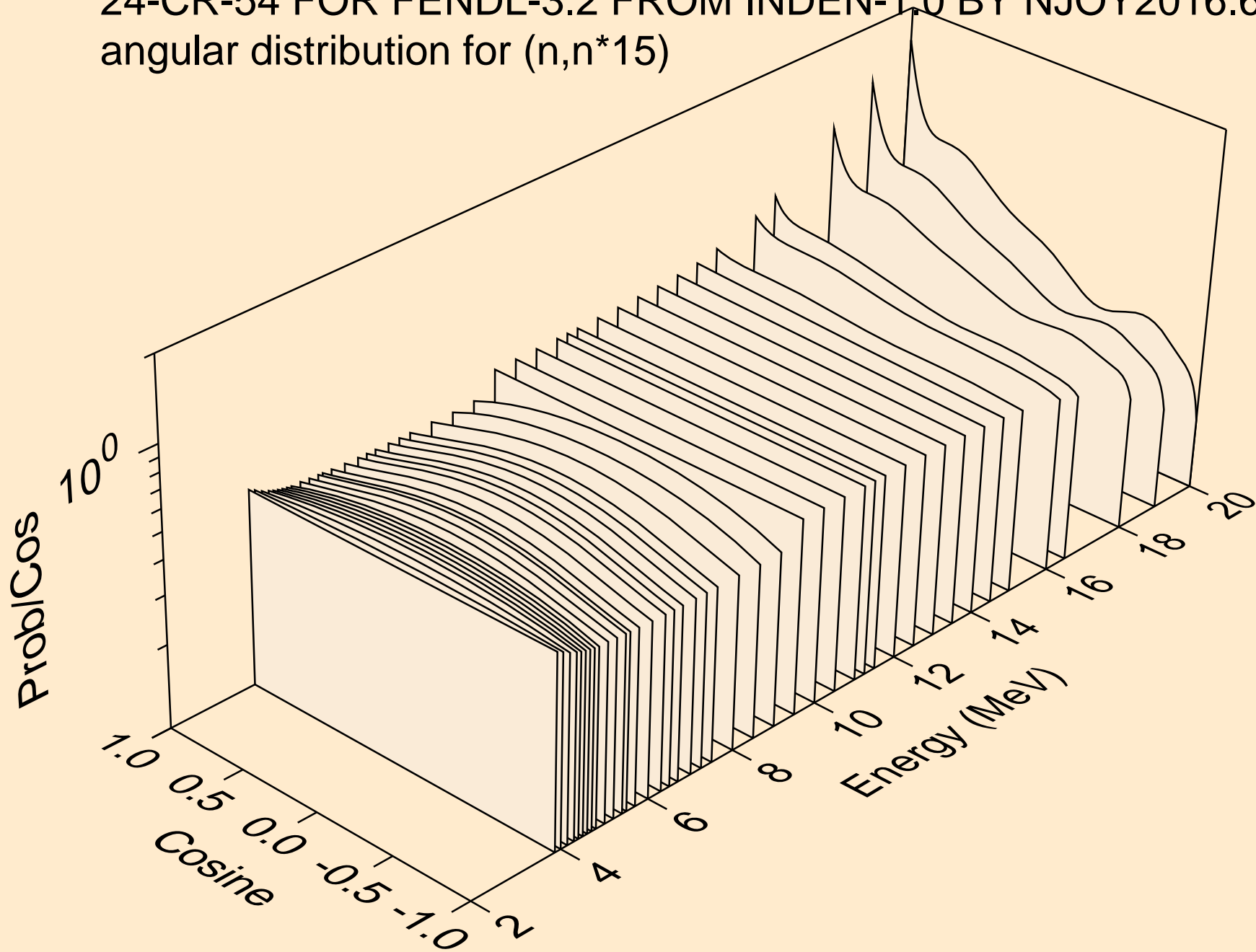

24-CR-54 FOR FENDL-3.2 FROM INDEN-1.0 BY NJOY2016.60+ OI
angular distribution for (n,n*15)

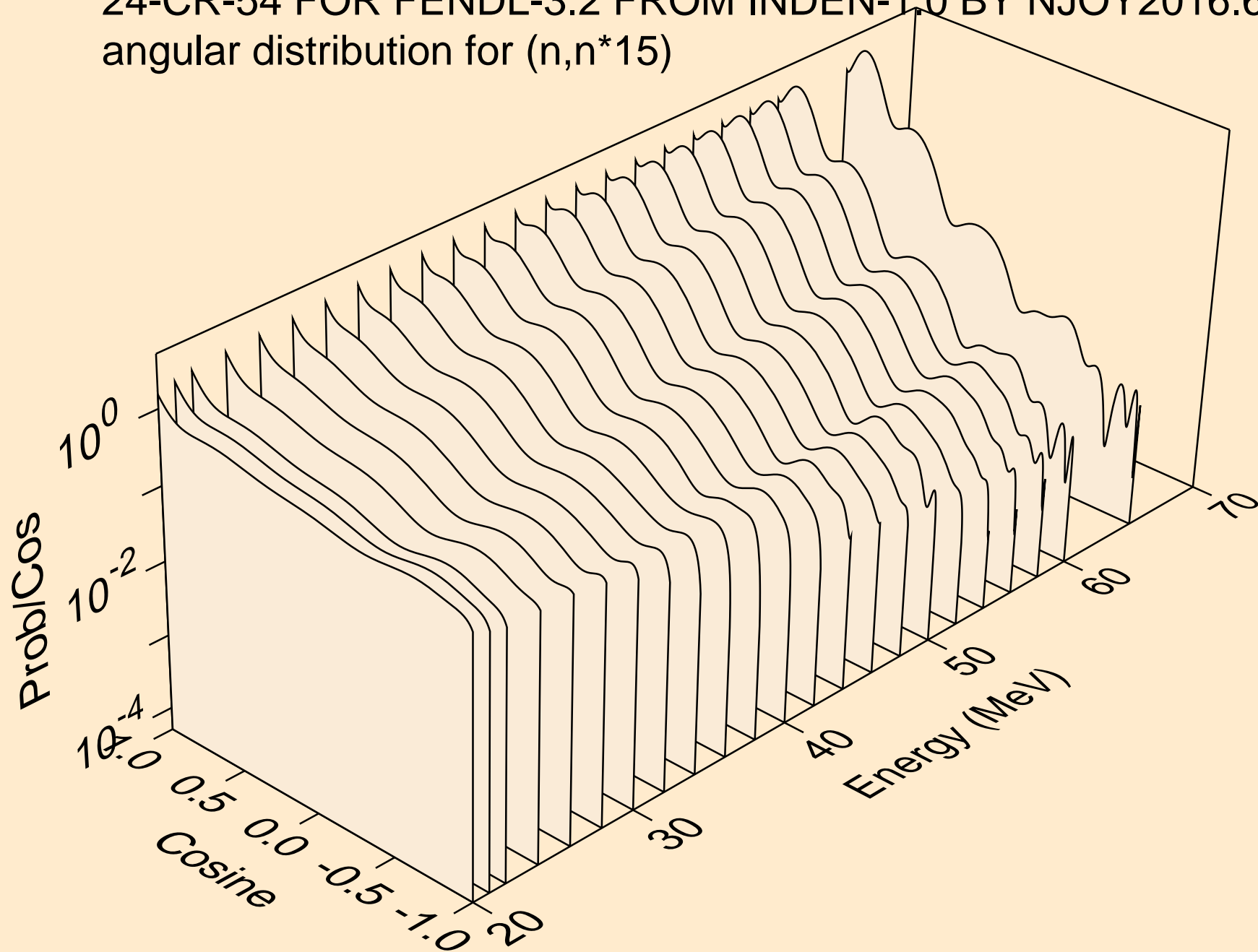

24-CR-54 FOR FENDL-3.2 FROM INDEN-1.0 BY NJOY2016.60+ OI
angular distribution for (n,n*16)

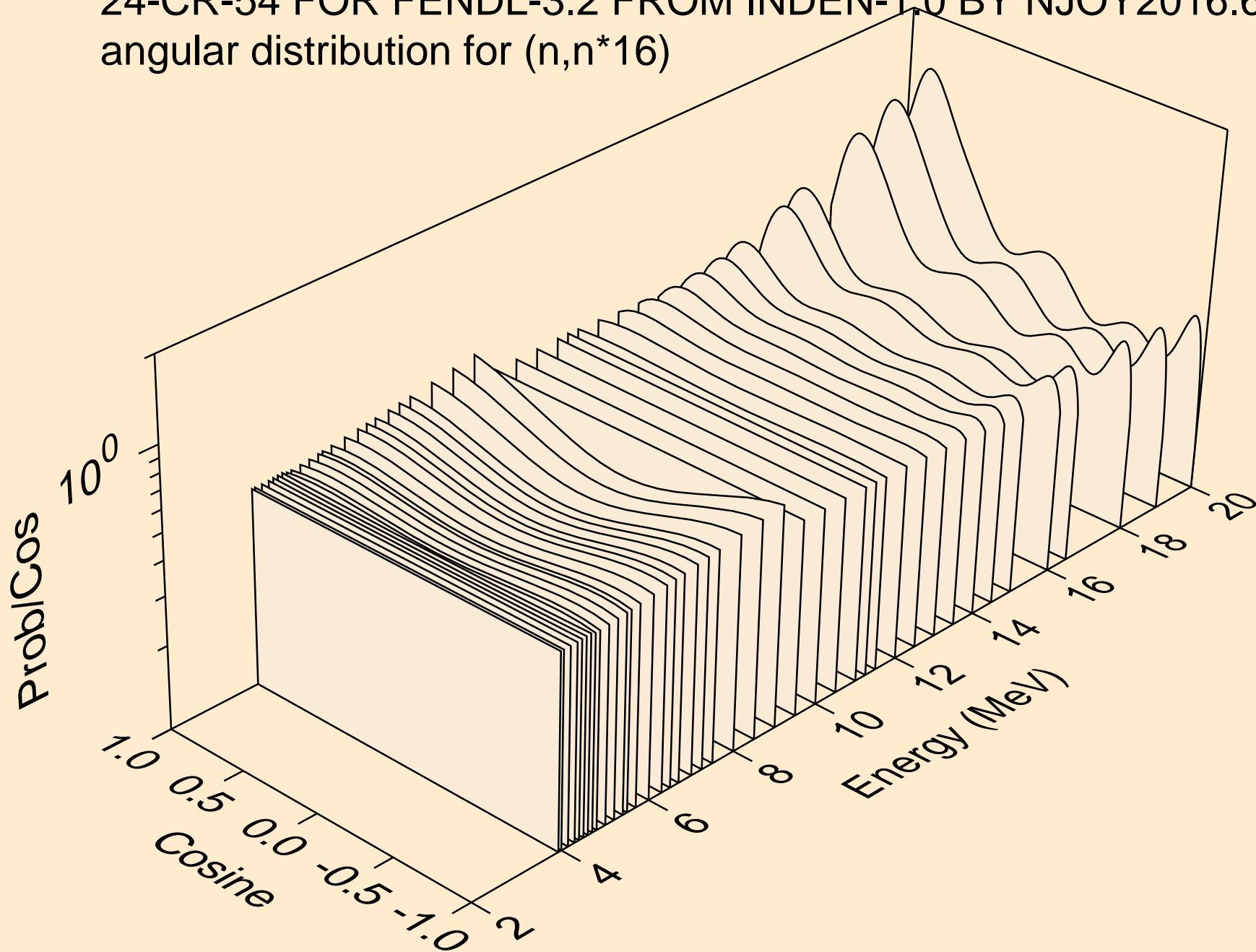

24-CR-54 FOR FENDL-3.2 FROM INDEN-1.0 BY NJOY2016.60+ OI
angular distribution for (n,n*16)

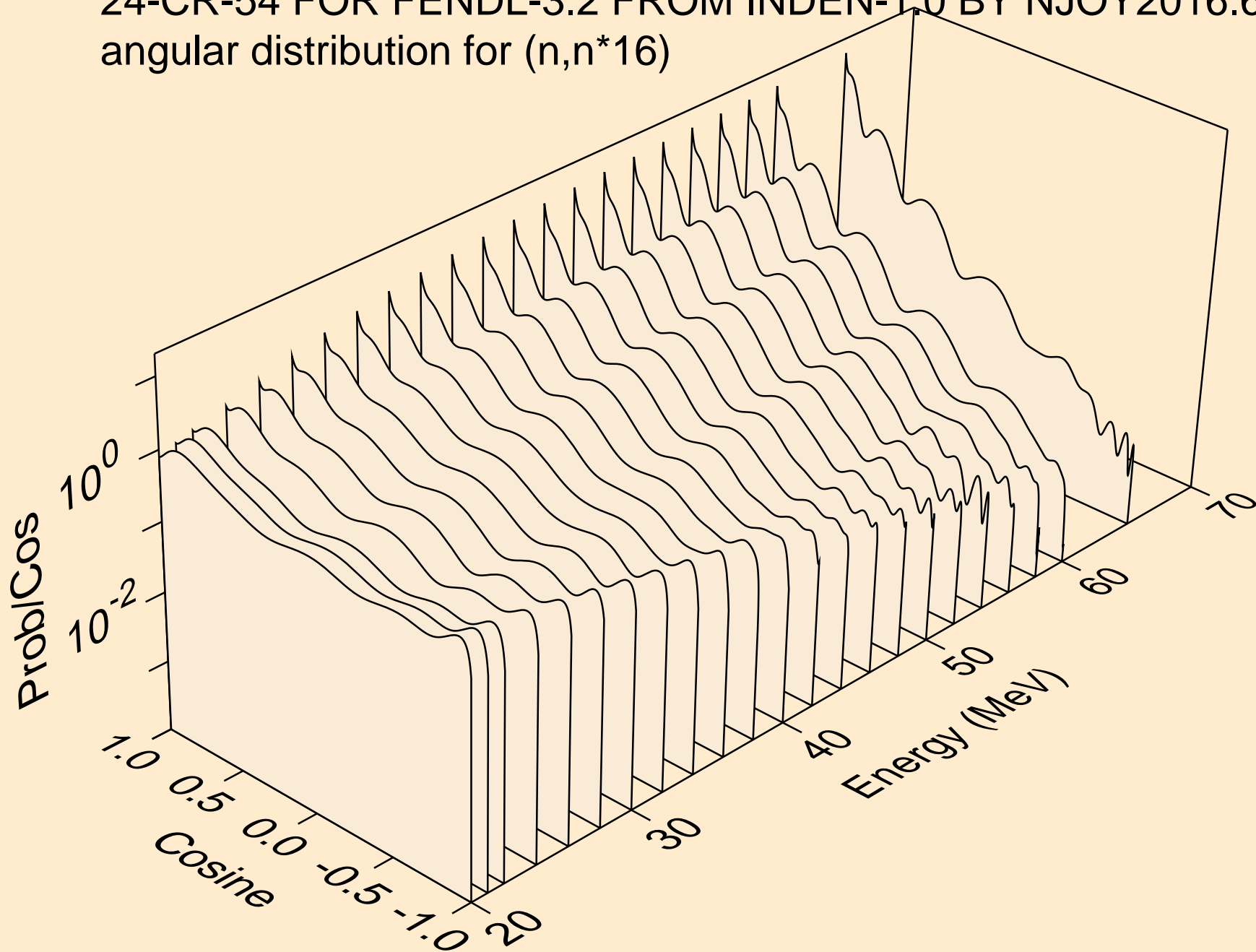

24-CR-54 FOR FENDL-3.2 FROM INDEN-1.0 BY NJOY2016.60+ OI
angular distribution for (n,n*17)

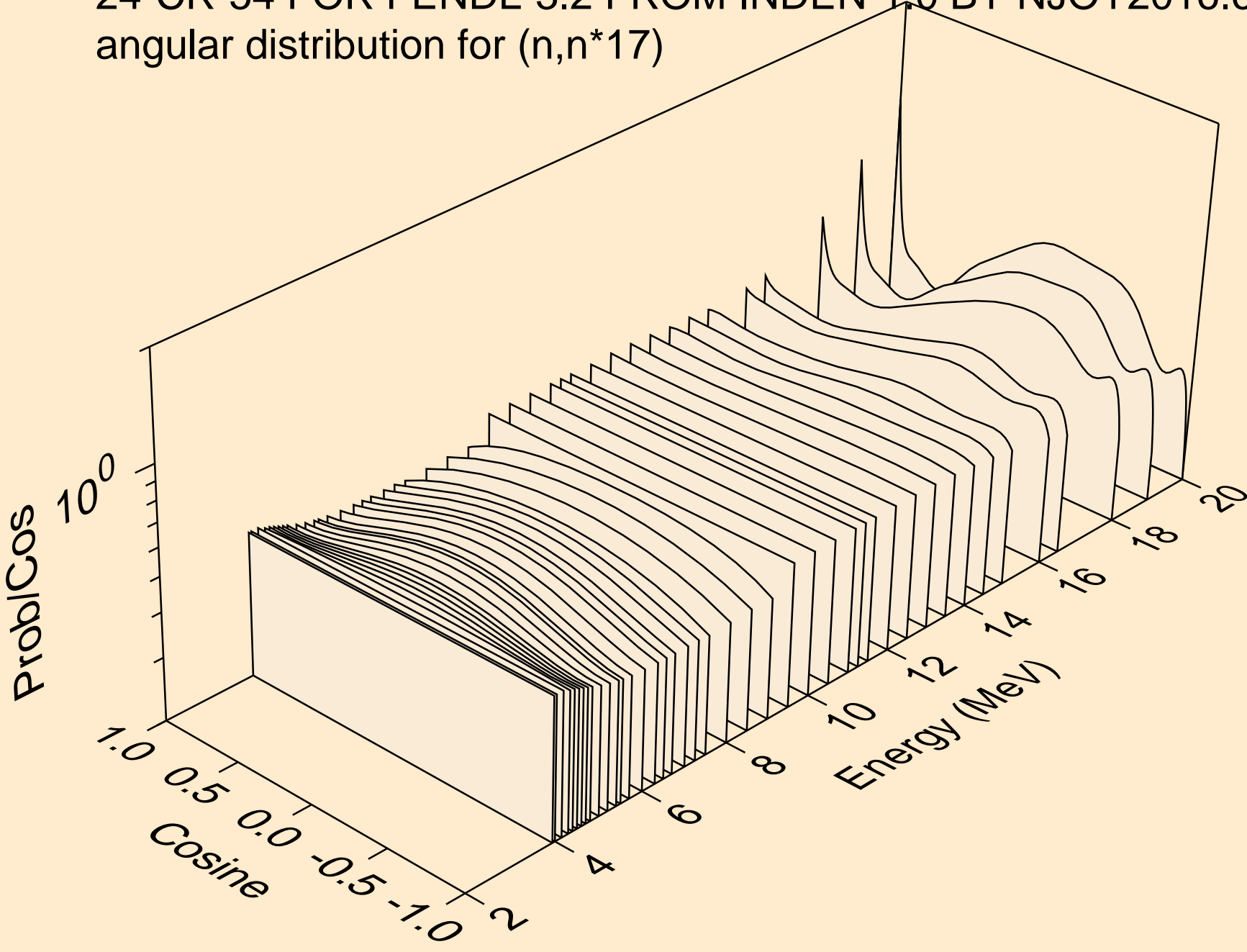

24-CR-54 FOR FENDL-3.2 FROM INDEN-1.0 BY NJOY2016.60+ OI
angular distribution for (n,n*17)

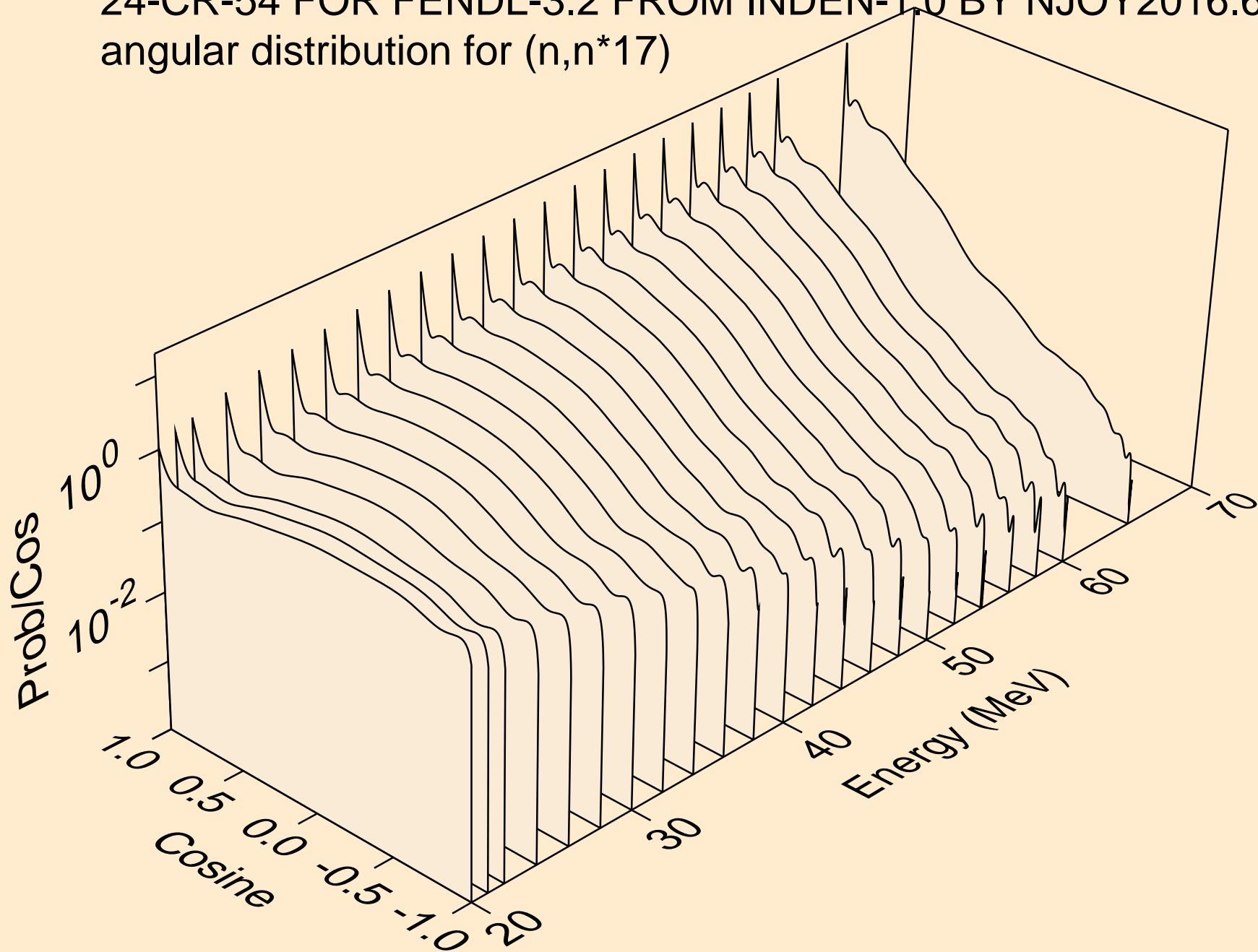

24-CR-54 FOR FENDL-3.2 FROM INDEN-1.0 BY NJOY2016.60+ OI
angular distribution for (n,n*18)

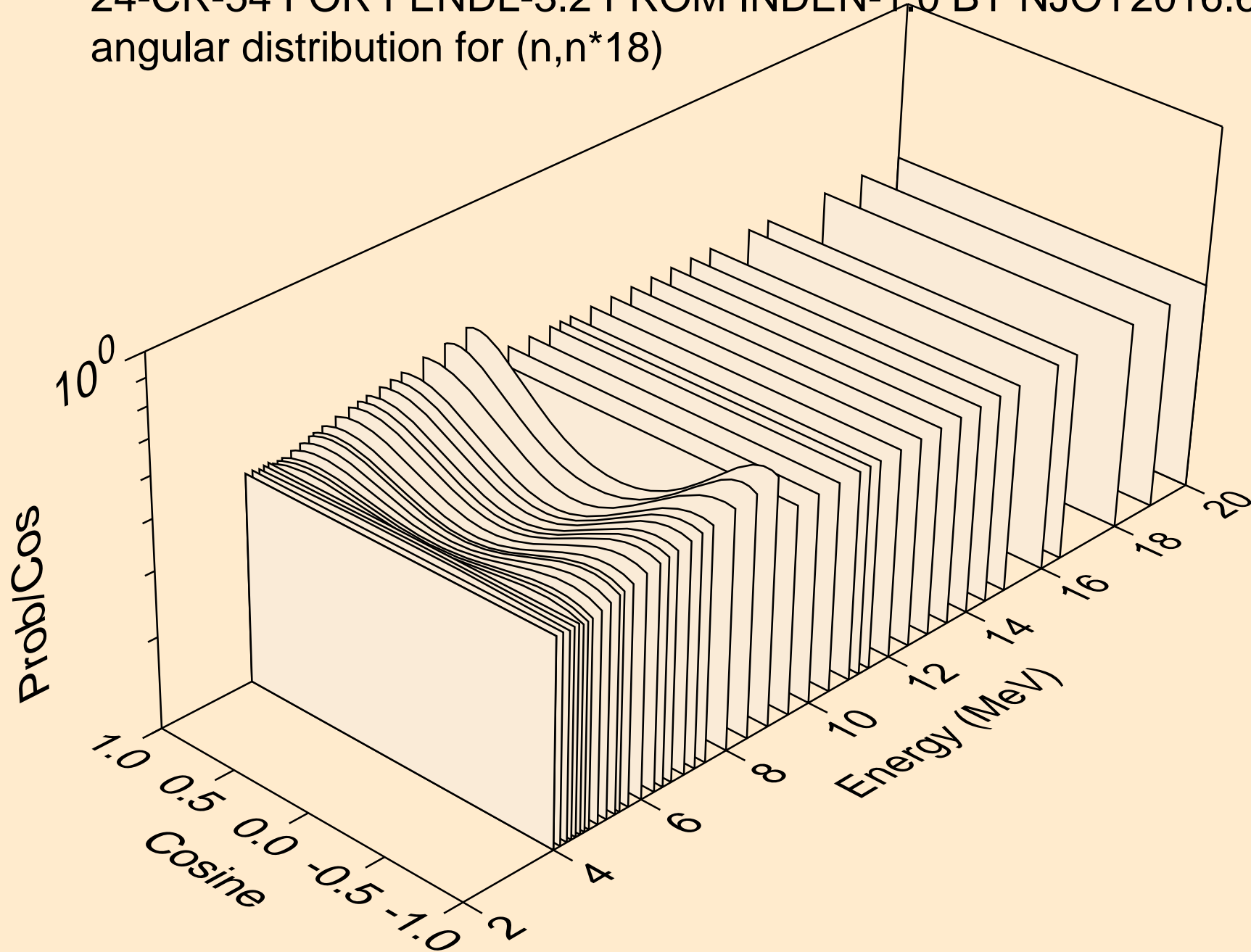

24-CR-54 FOR FENDL-3.2 FROM INDEN-1.0 BY NJOY2016.60+ OI
angular distribution for (n,n*18)

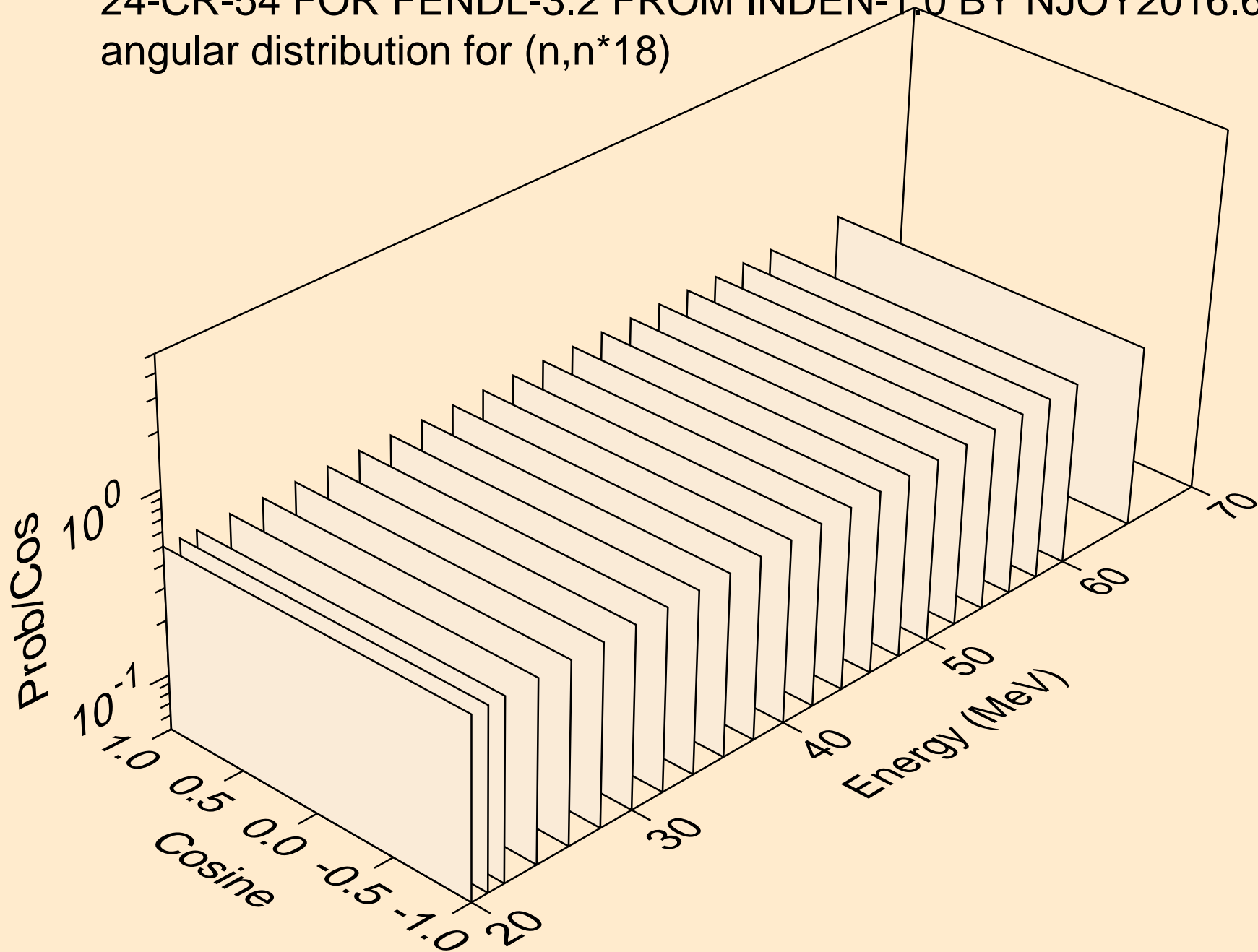

24-CR-54 FOR FENDL-3.2 FROM INDEN-1.0 BY NJOY2016.60+ OI
angular distribution for (n,n*19)

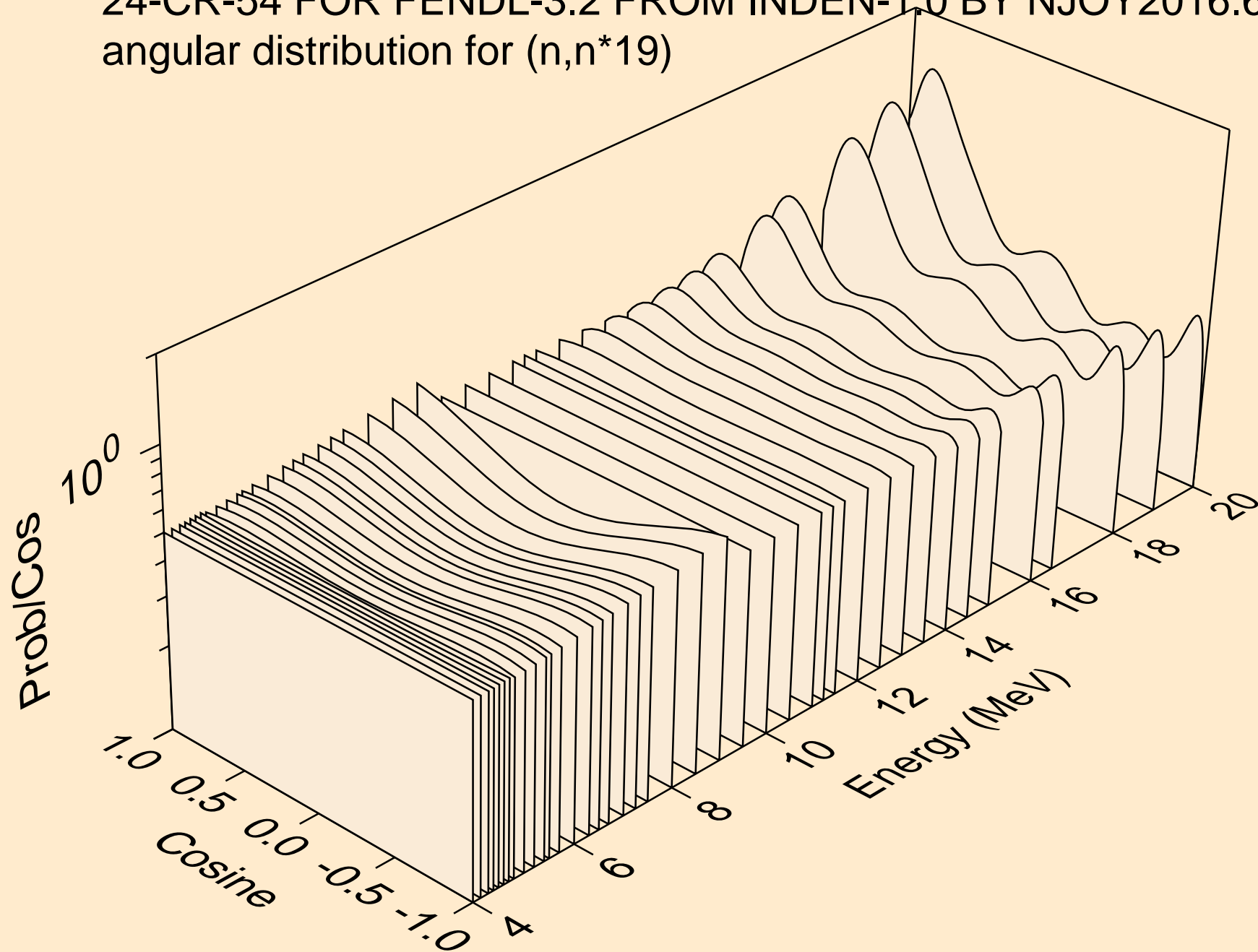

24-CR-54 FOR FENDL-3.2 FROM INDEN-1.0 BY NJOY2016.60+ OI
angular distribution for (n,n*19)

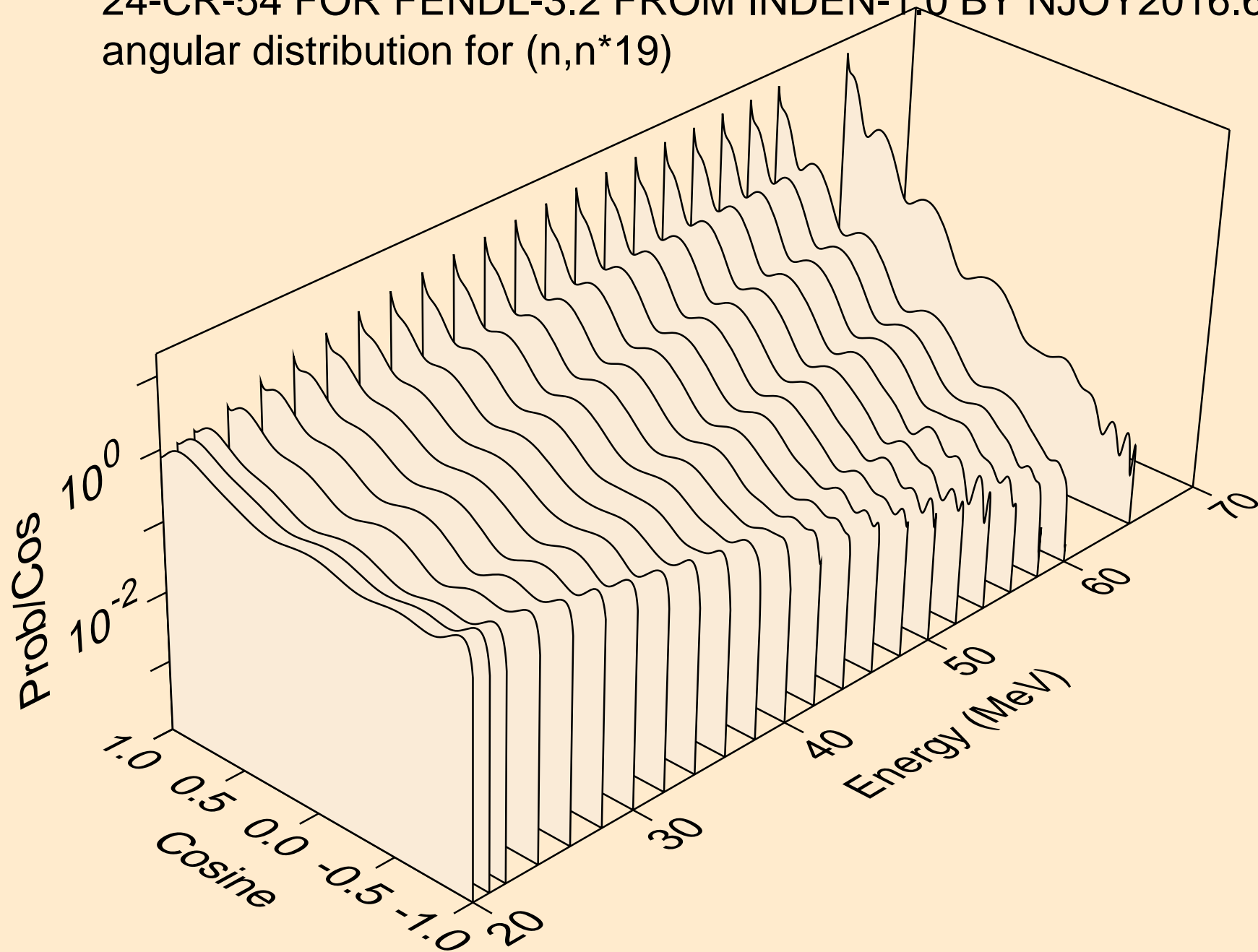

24-CR-54 FOR FENDL-3.2 FROM INDEN-1.0 BY NJOY2016.60+ OI
angular distribution for (n,n*20)

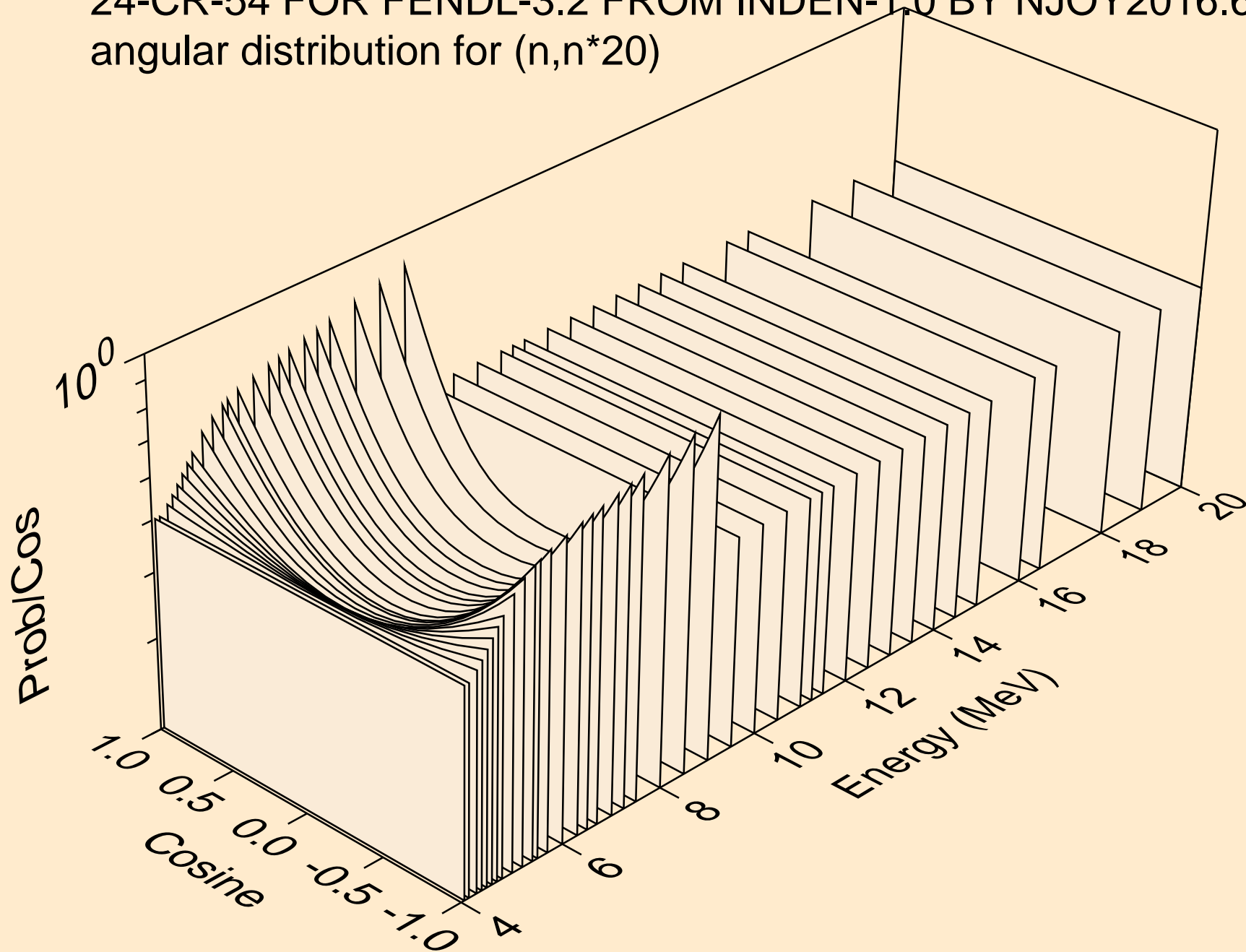

24-CR-54 FOR FENDL-3.2 FROM INDEN-1.0 BY NJOY2016.60+ OI
angular distribution for (n,n*20)

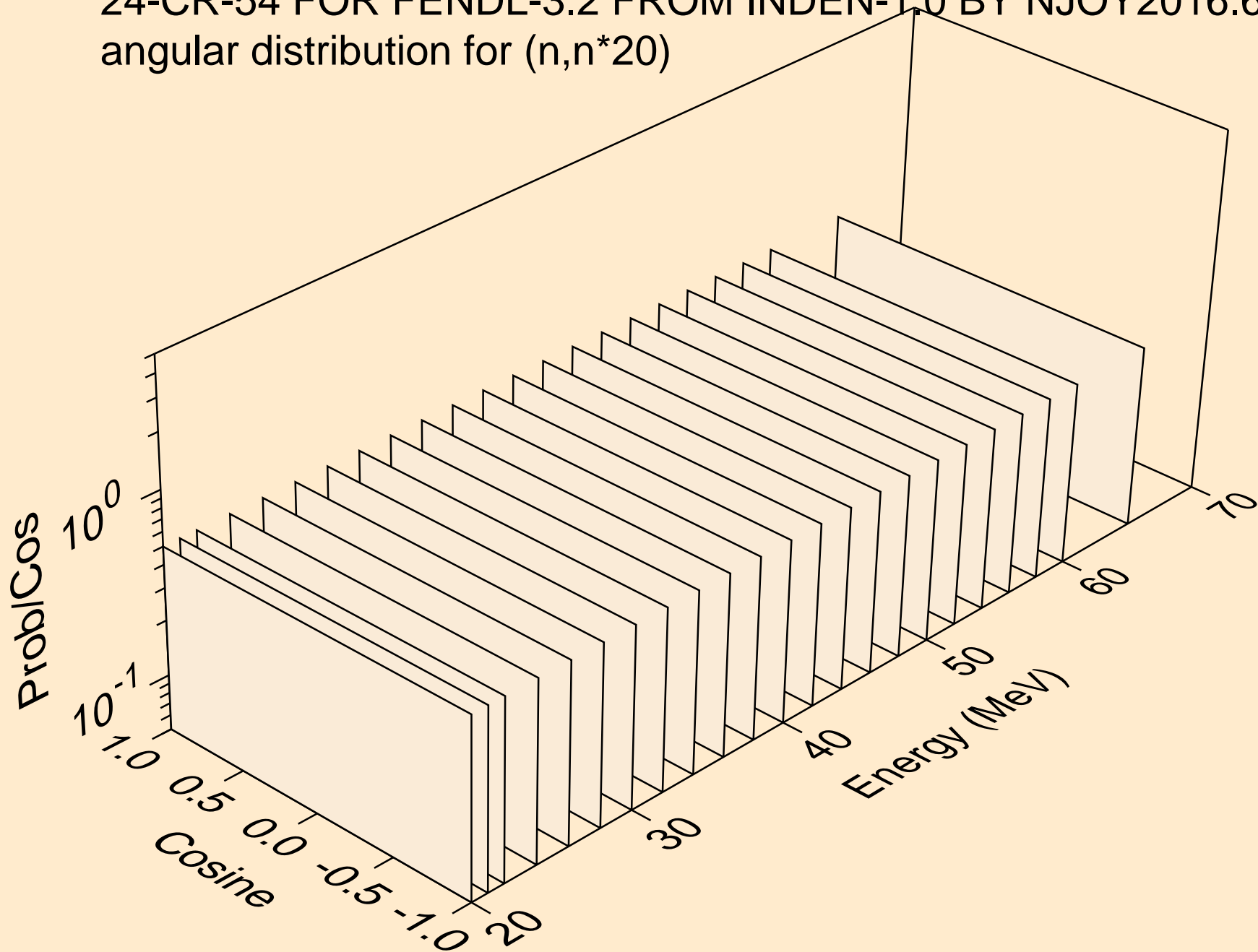

24-CR-54 FOR FENDL-3.2 FROM INDEN-1.0 BY NJOY2016.60+ OI
angular distribution for (n,n*21)

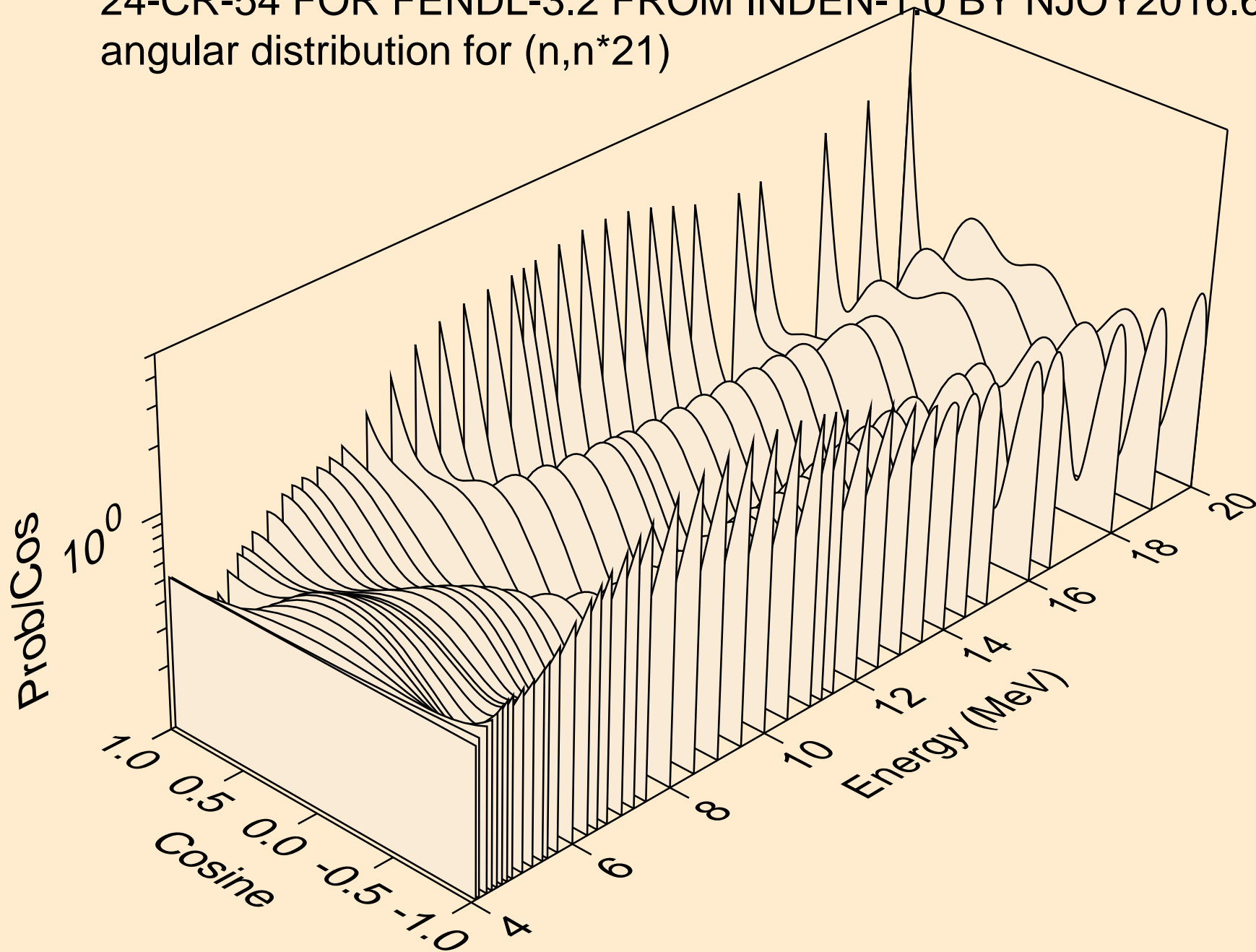

24-CR-54 FOR FENDL-3.2 FROM INDEN-1.0 BY NJOY2016.60+ OI
angular distribution for (n,n*21)

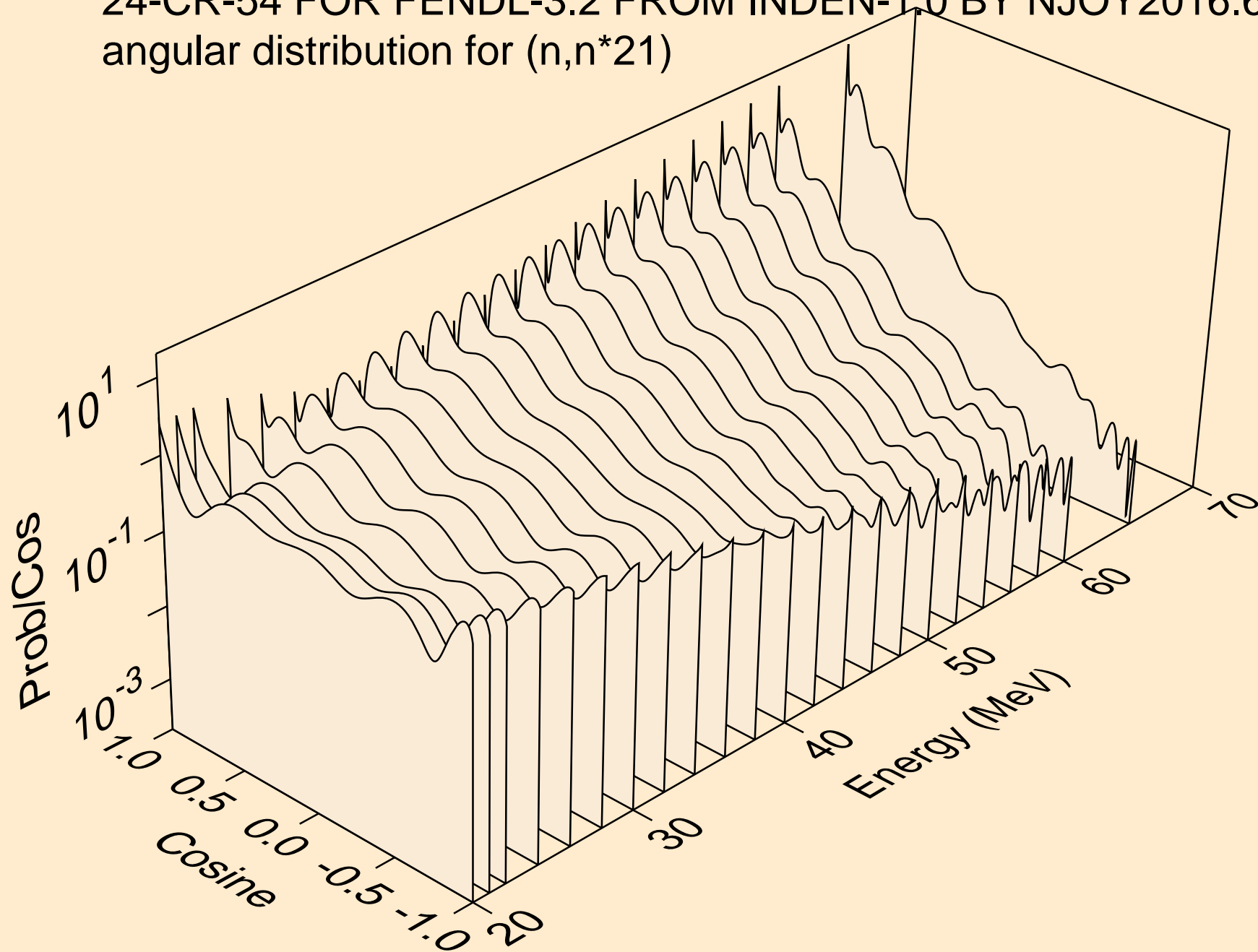

24-CR-54 FOR FENDL-3.2 FROM INDEN-1.0 BY NJOY2016.60+ OI
angular distribution for (n,n*22)

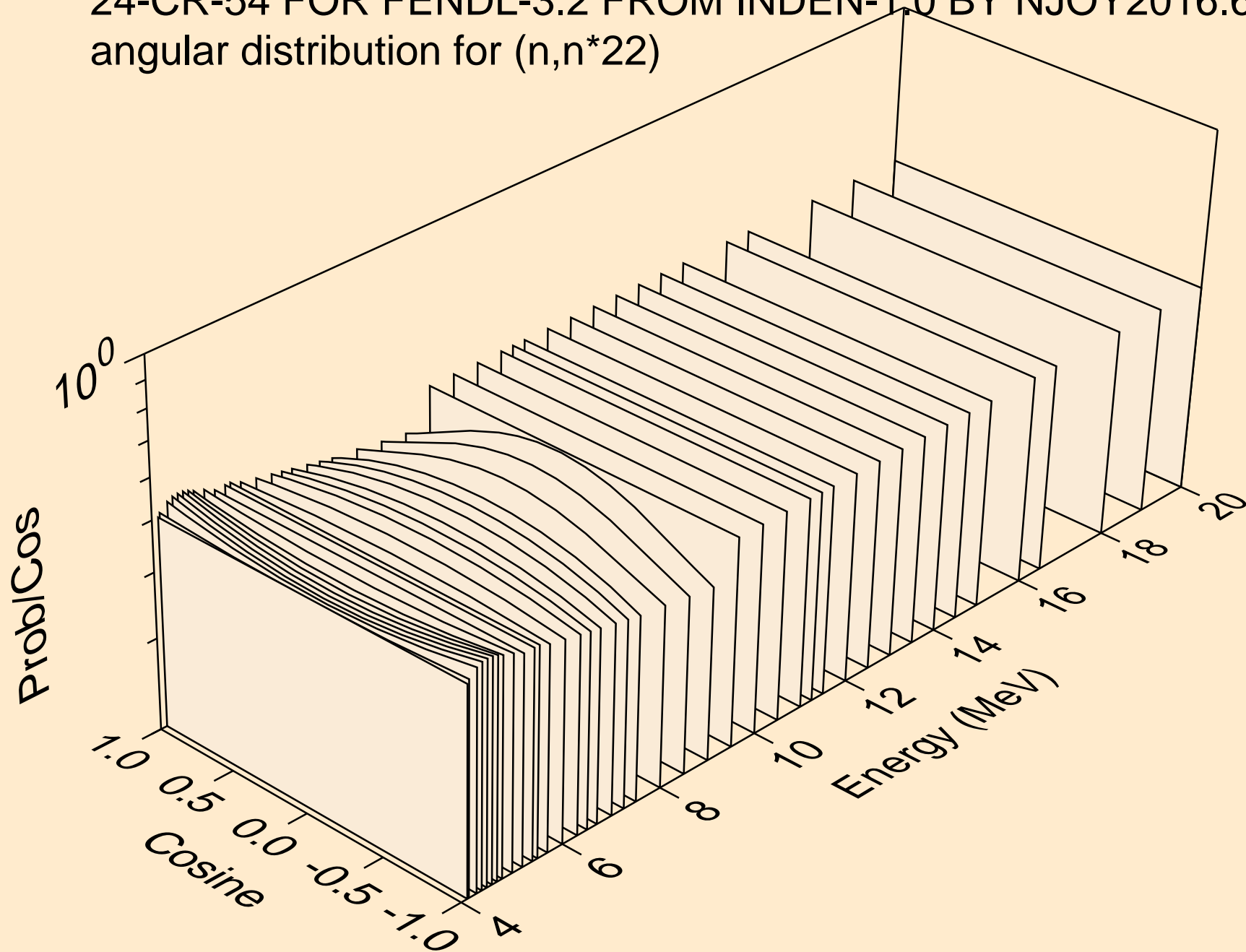

24-CR-54 FOR FENDL-3.2 FROM INDEN-1.0 BY NJOY2016.60+ OI
angular distribution for (n,n*22)

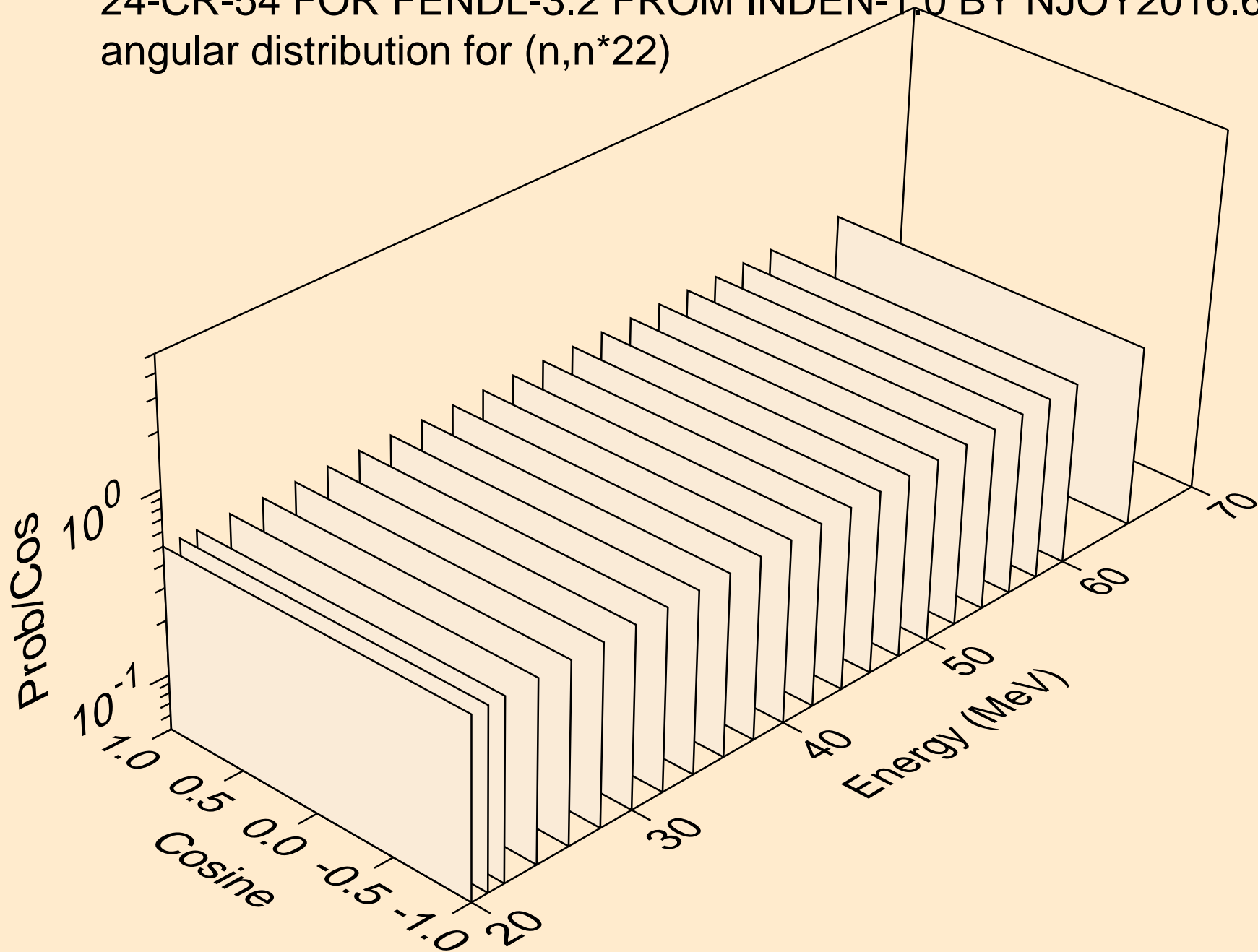

24-CR-54 FOR FENDL-3.2 FROM INDEN-1.0 BY NJOY2016.60+ OI
angular distribution for (n,n*23)

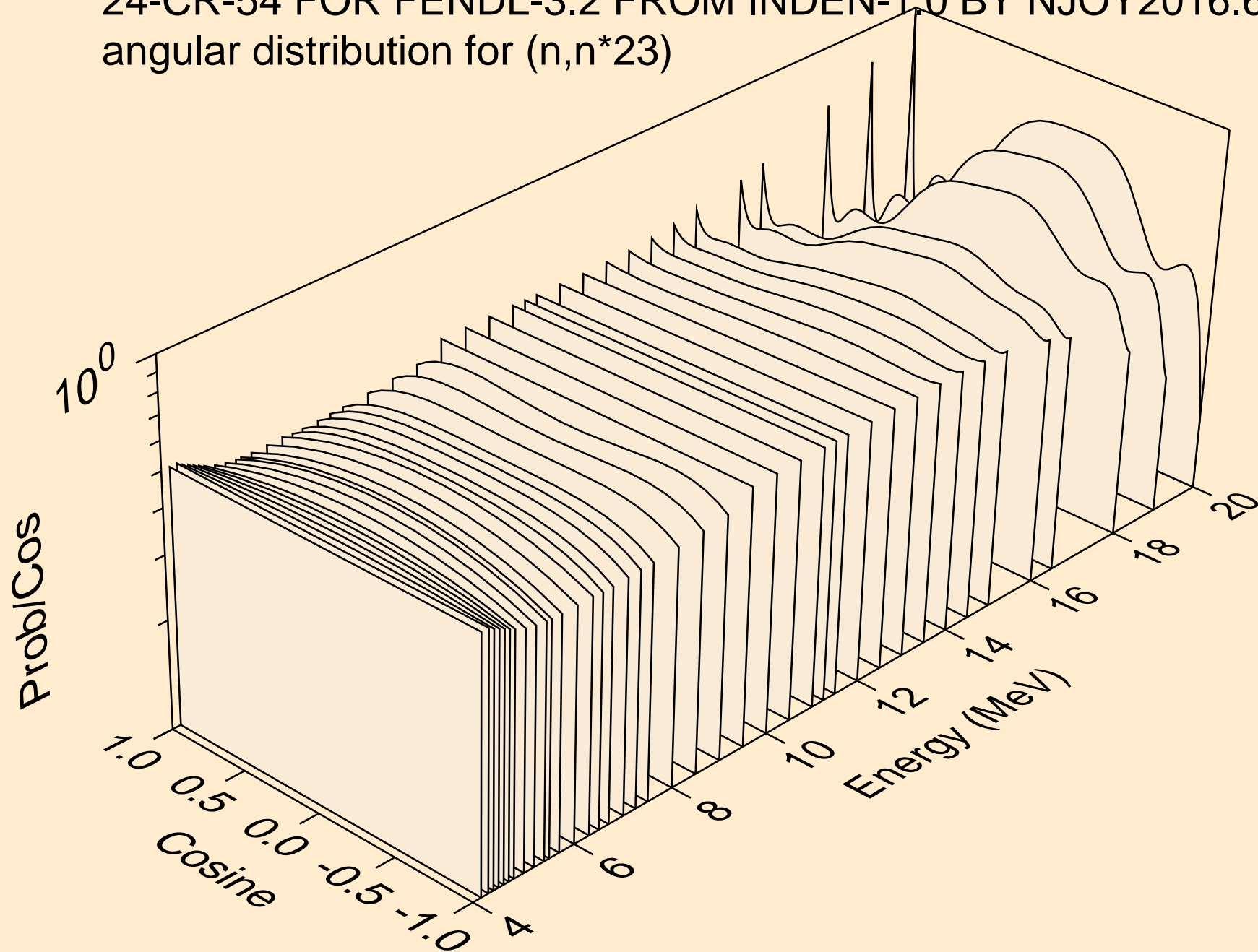

24-CR-54 FOR FENDL-3.2 FROM INDEN-1.0 BY NJOY2016.60+ OI
angular distribution for (n,n*23)

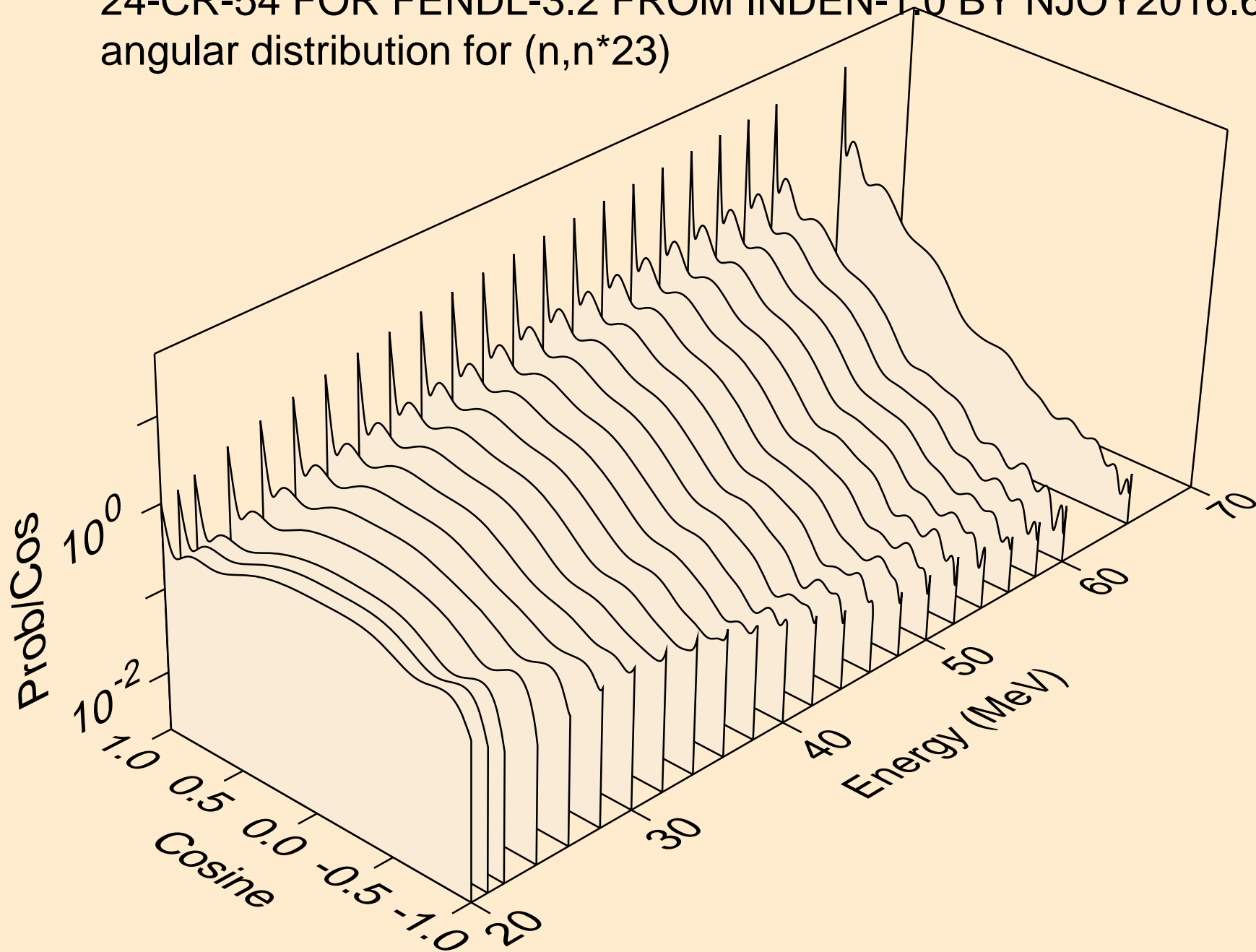

24-CR-54 FOR FENDL-3.2 FROM INDEN-1.0 BY NJOY2016.60+ OI
angular distribution for (n,n*24)

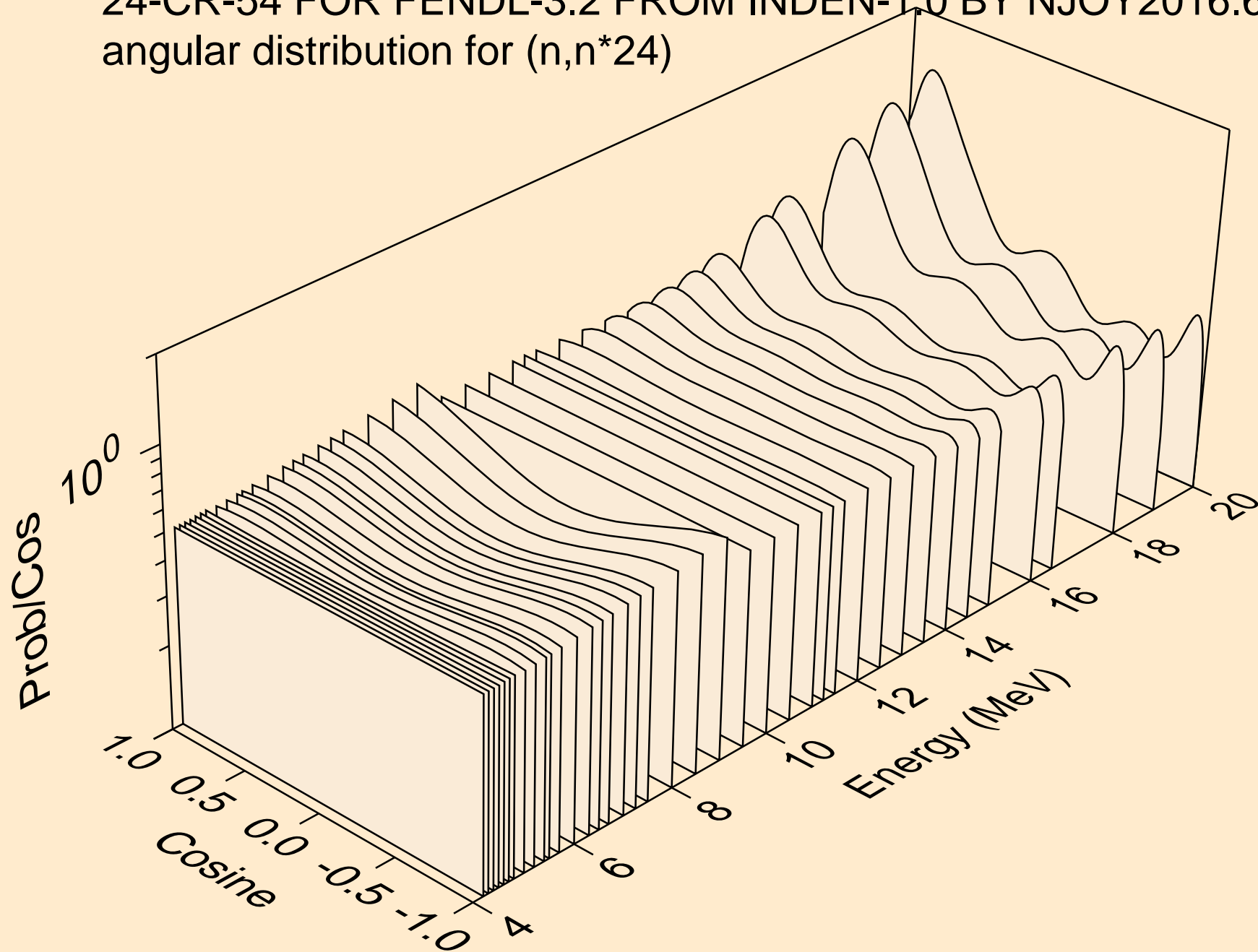

24-CR-54 FOR FENDL-3.2 FROM INDEN-1.0 BY NJOY2016.60+ OI
angular distribution for (n,n*24)

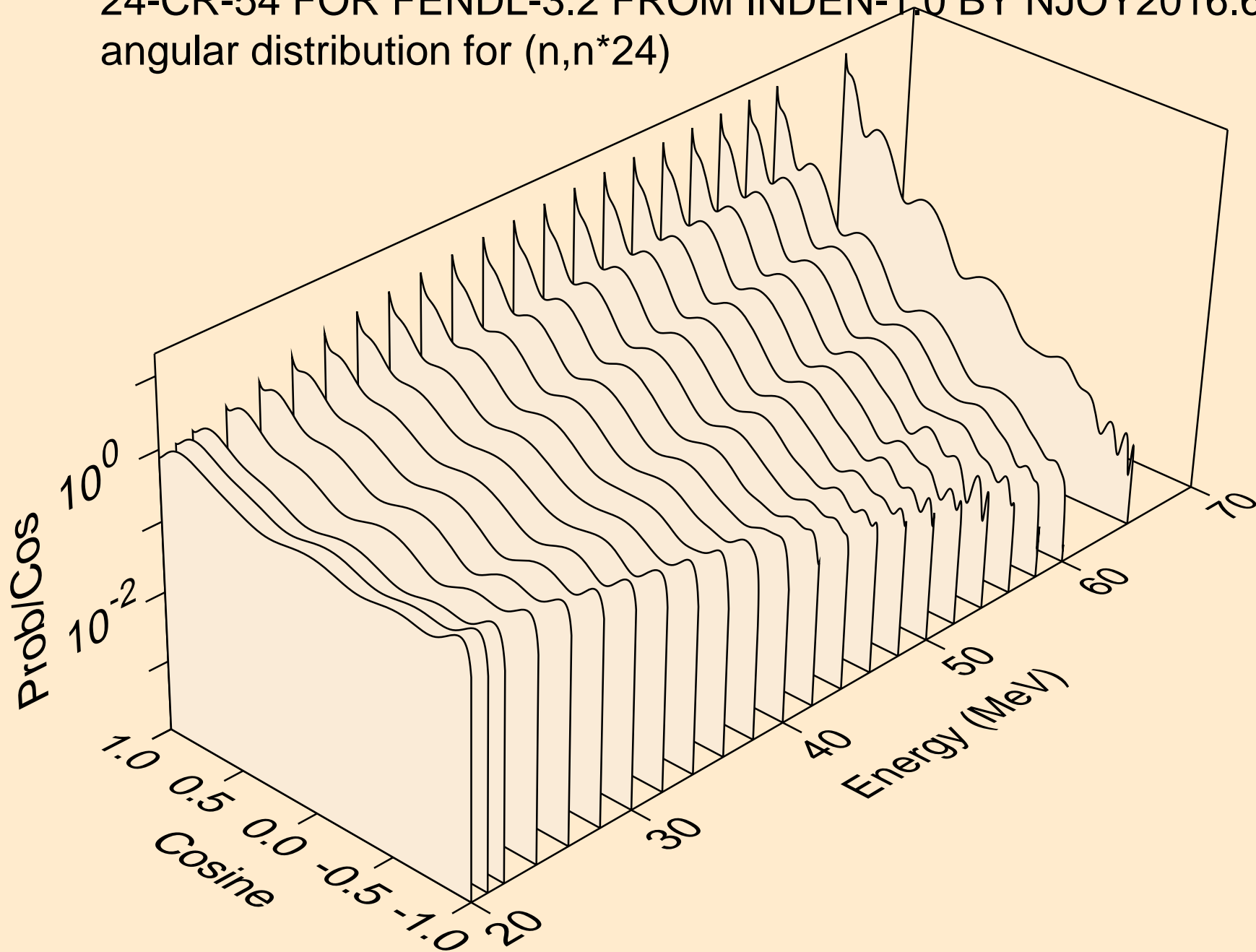

24-CR-54 FOR FENDL-3.2 FROM INDEN-1.0 BY NJOY2016.60+ OI
angular distribution for (n,n*25)

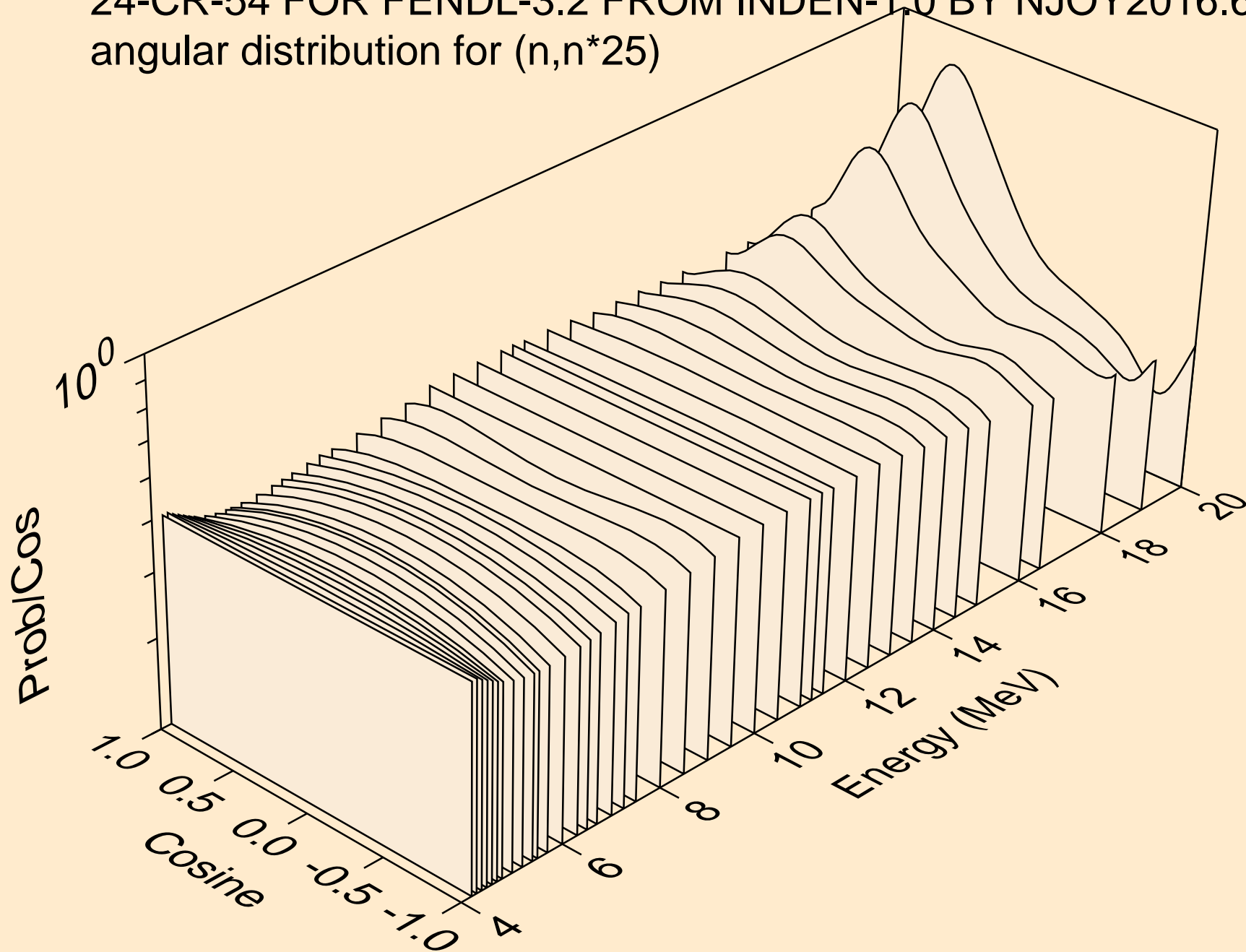

24-CR-54 FOR FENDL-3.2 FROM INDEN-1.0 BY NJOY2016.60+ OI
angular distribution for (n,n*25)

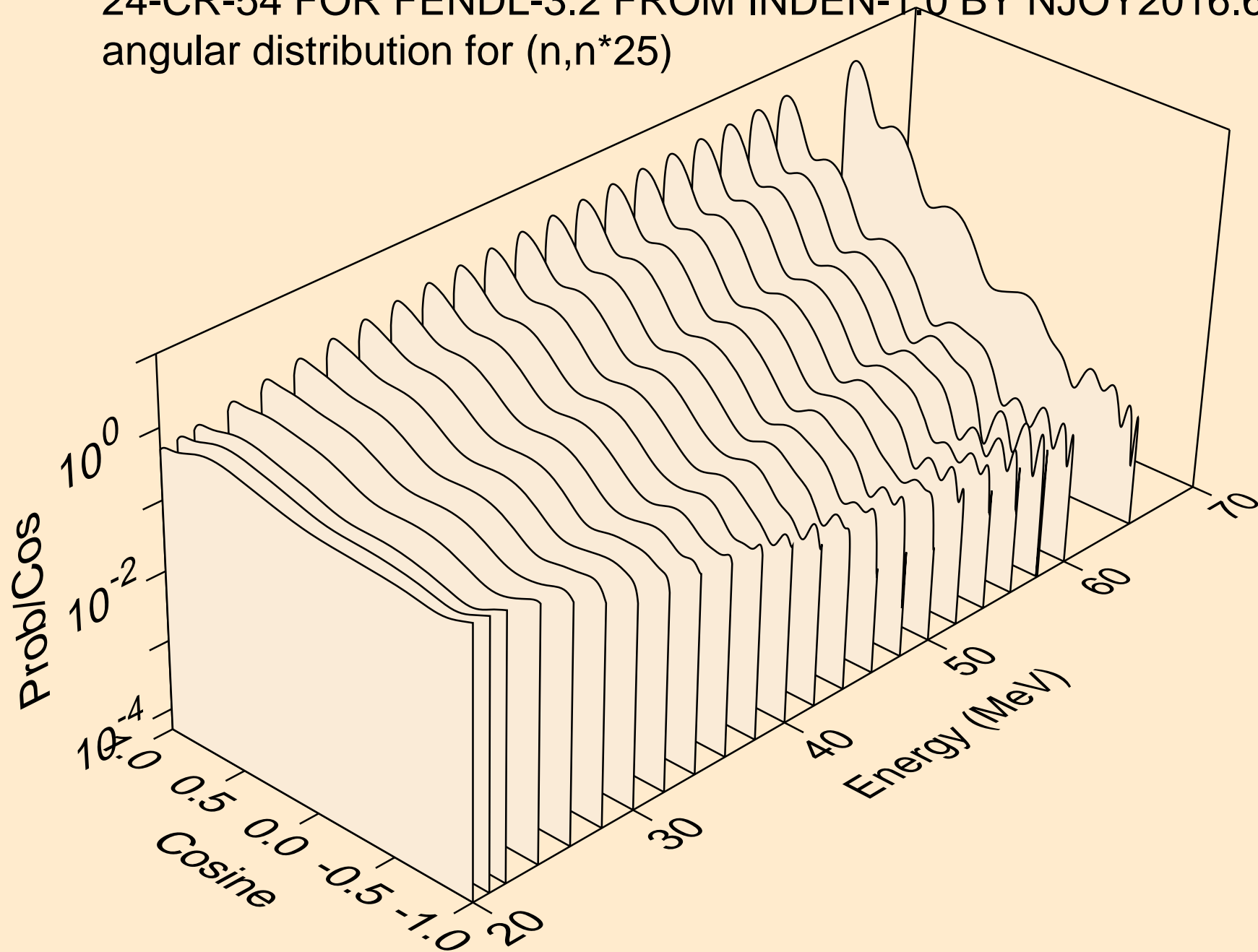

24-CR-54 FOR FENDL-3.2 FROM INDEN-1.0 BY NJOY2016.60+ OI
angular distribution for (n,n*26)

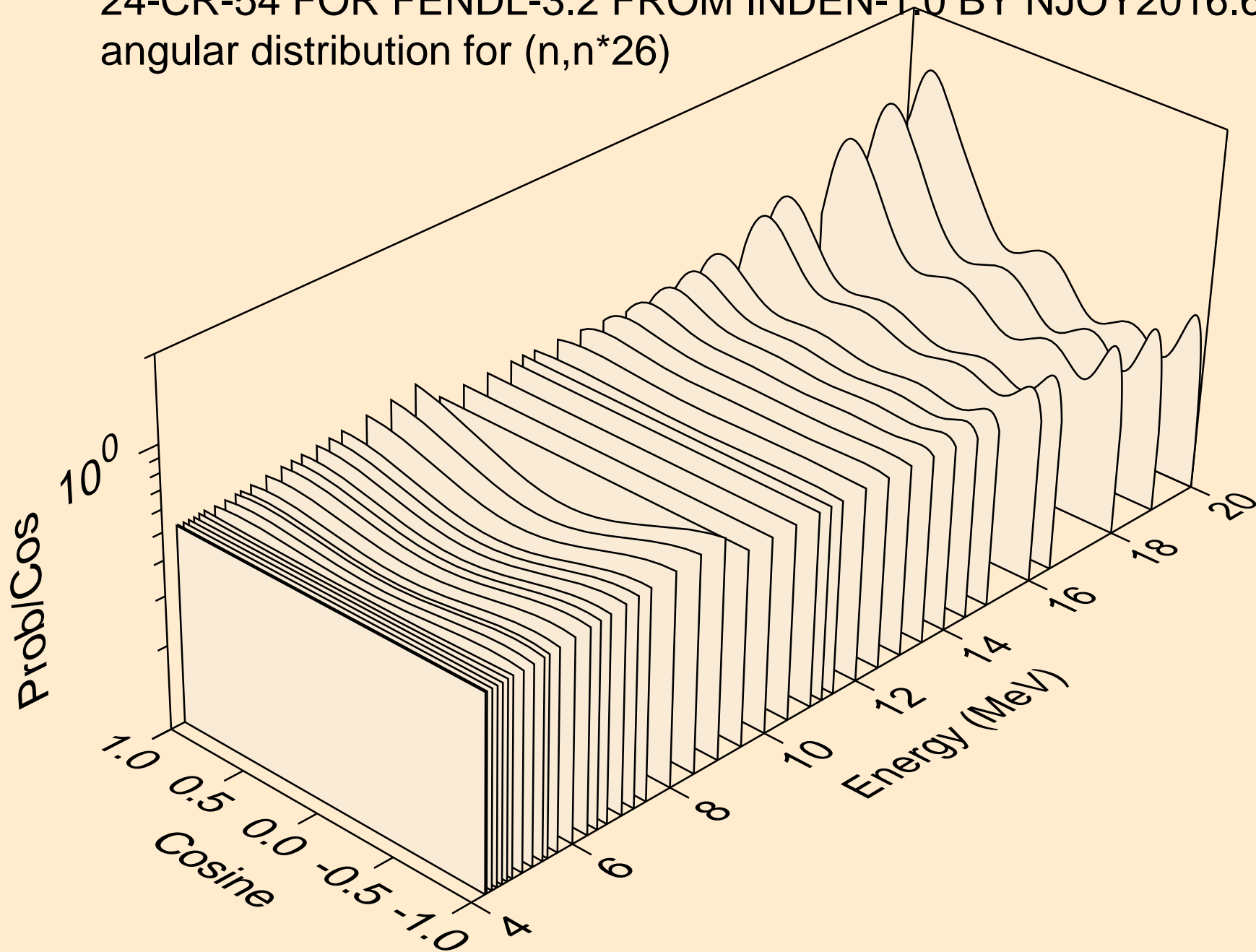

24-CR-54 FOR FENDL-3.2 FROM INDEN-1.0 BY NJOY2016.60+ OI
angular distribution for (n,n*26)

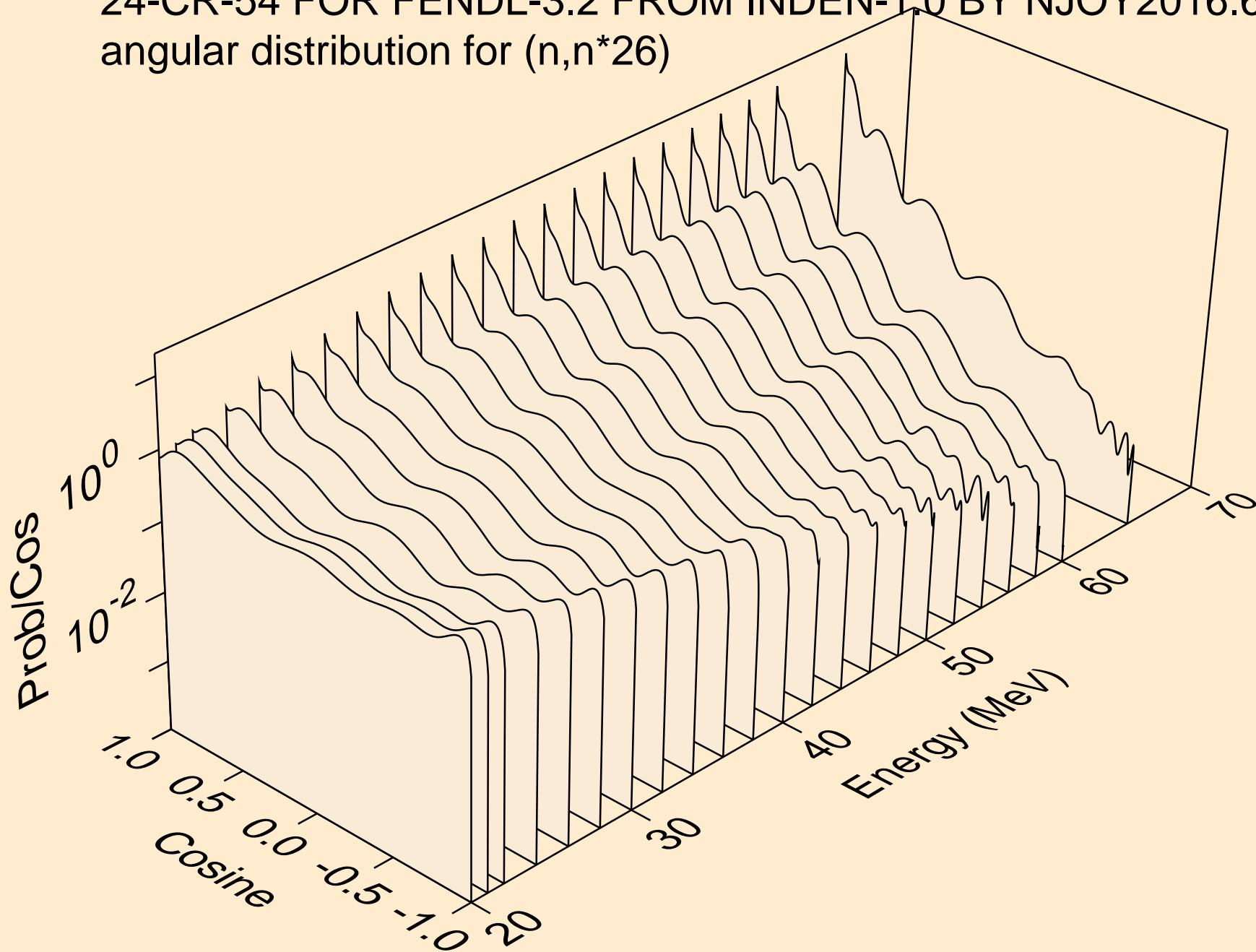

24-CR-54 FOR FENDL-3.2 FROM INDEN-1.0 BY NJOY2016.60+ OI
angular distribution for (n,n*27)

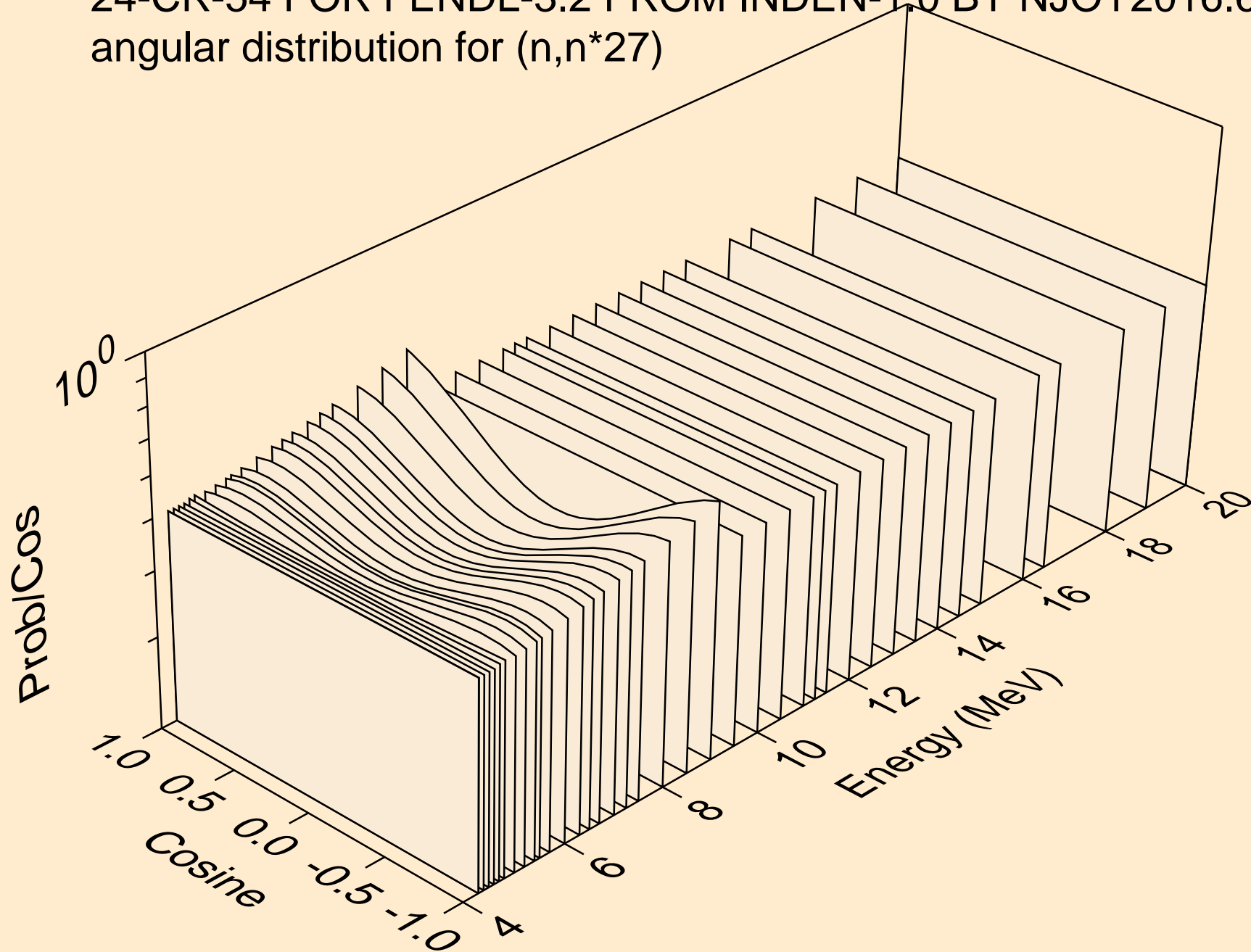

24-CR-54 FOR FENDL-3.2 FROM INDEN-1.0 BY NJOY2016.60+ OI
angular distribution for (n,n*27)

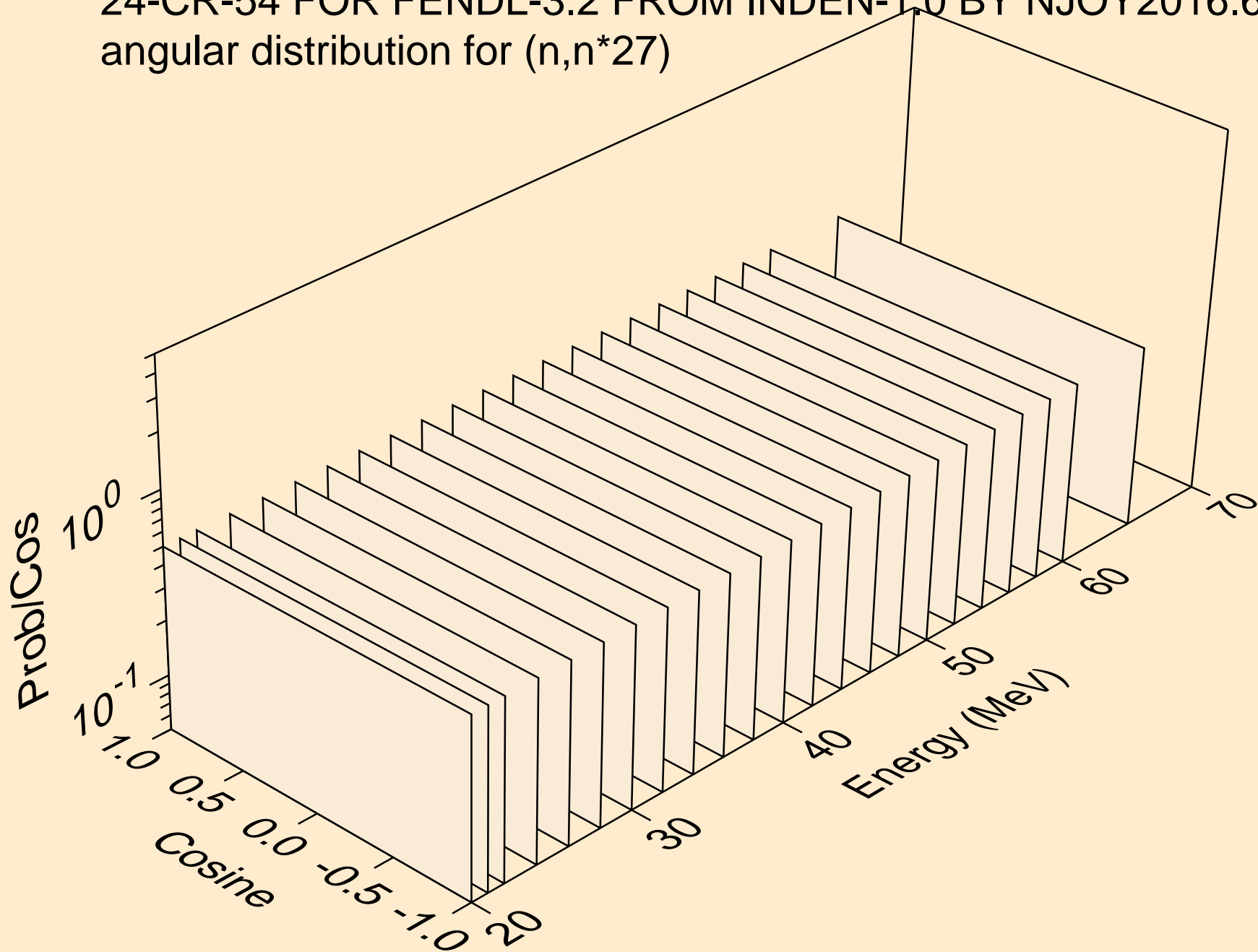

24-CR-54 FOR FENDL-3.2 FROM INDEN-1.0 BY NJOY2016.60+ OI
angular distribution for (n,n*28)

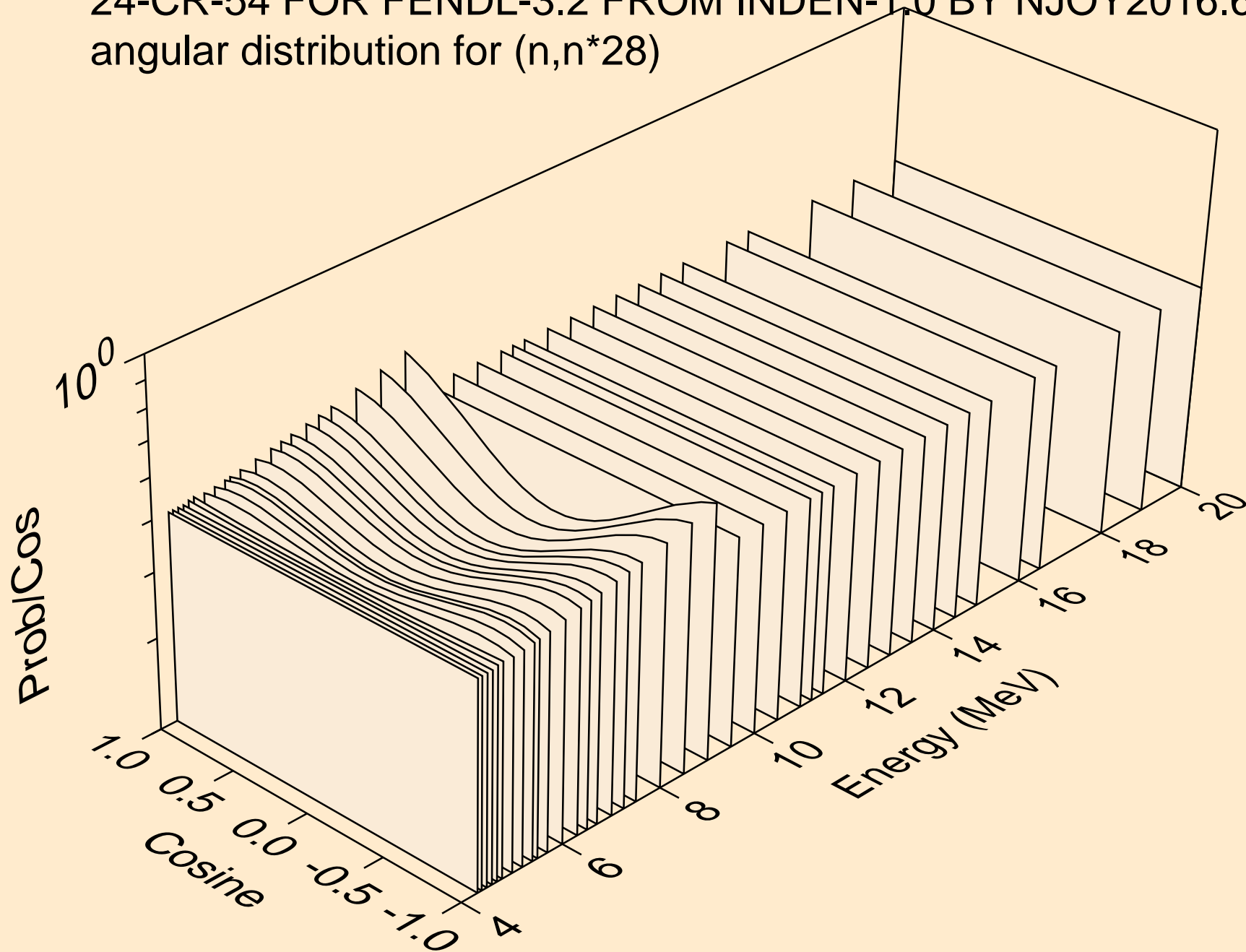

24-CR-54 FOR FENDL-3.2 FROM INDEN-1.0 BY NJOY2016.60+ OI
angular distribution for (n,n*28)

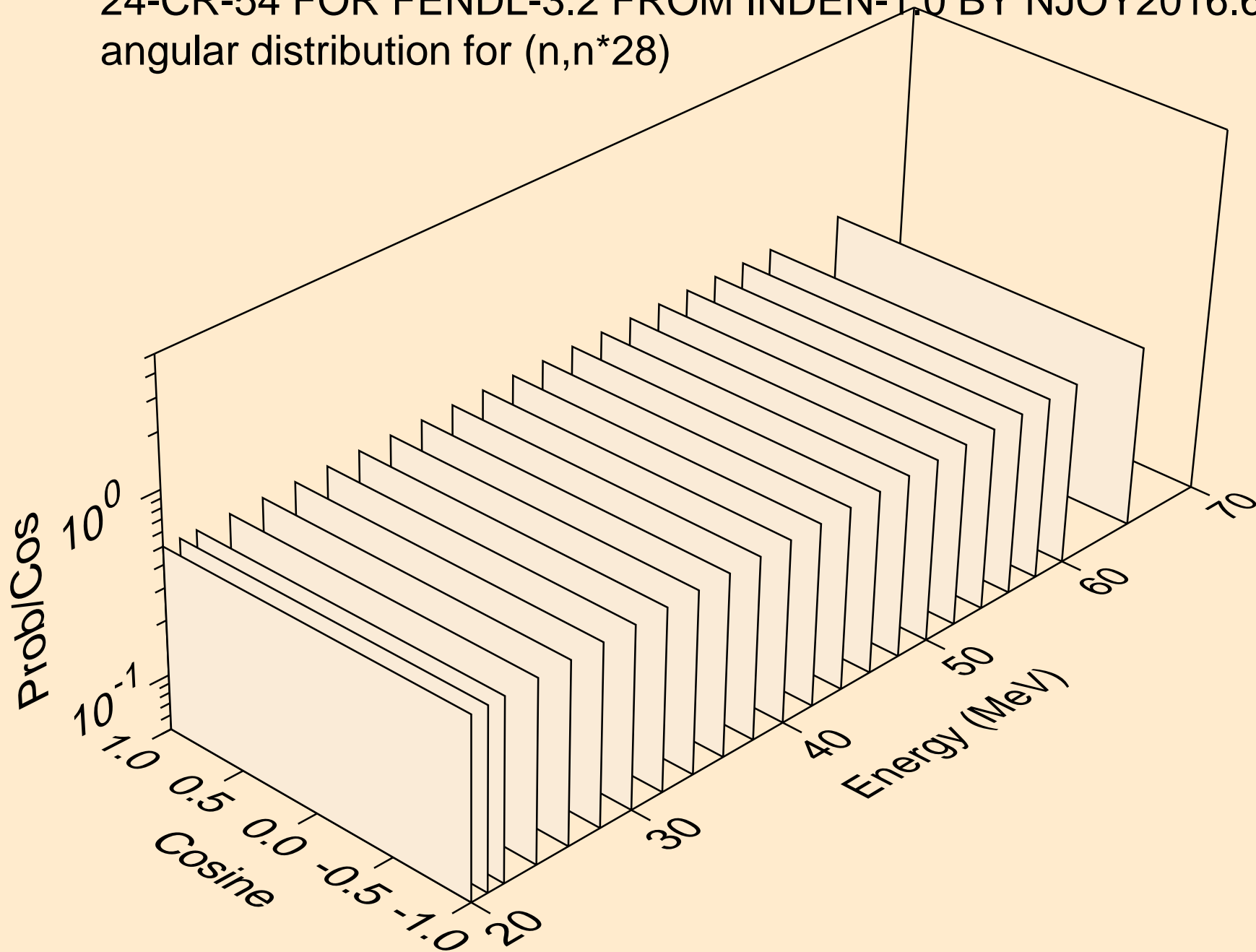

24-CR-54 FOR FENDL-3.2 FROM INDEN-1.0 BY NJOY2016.60+ OI
angular distribution for (n,n*29)

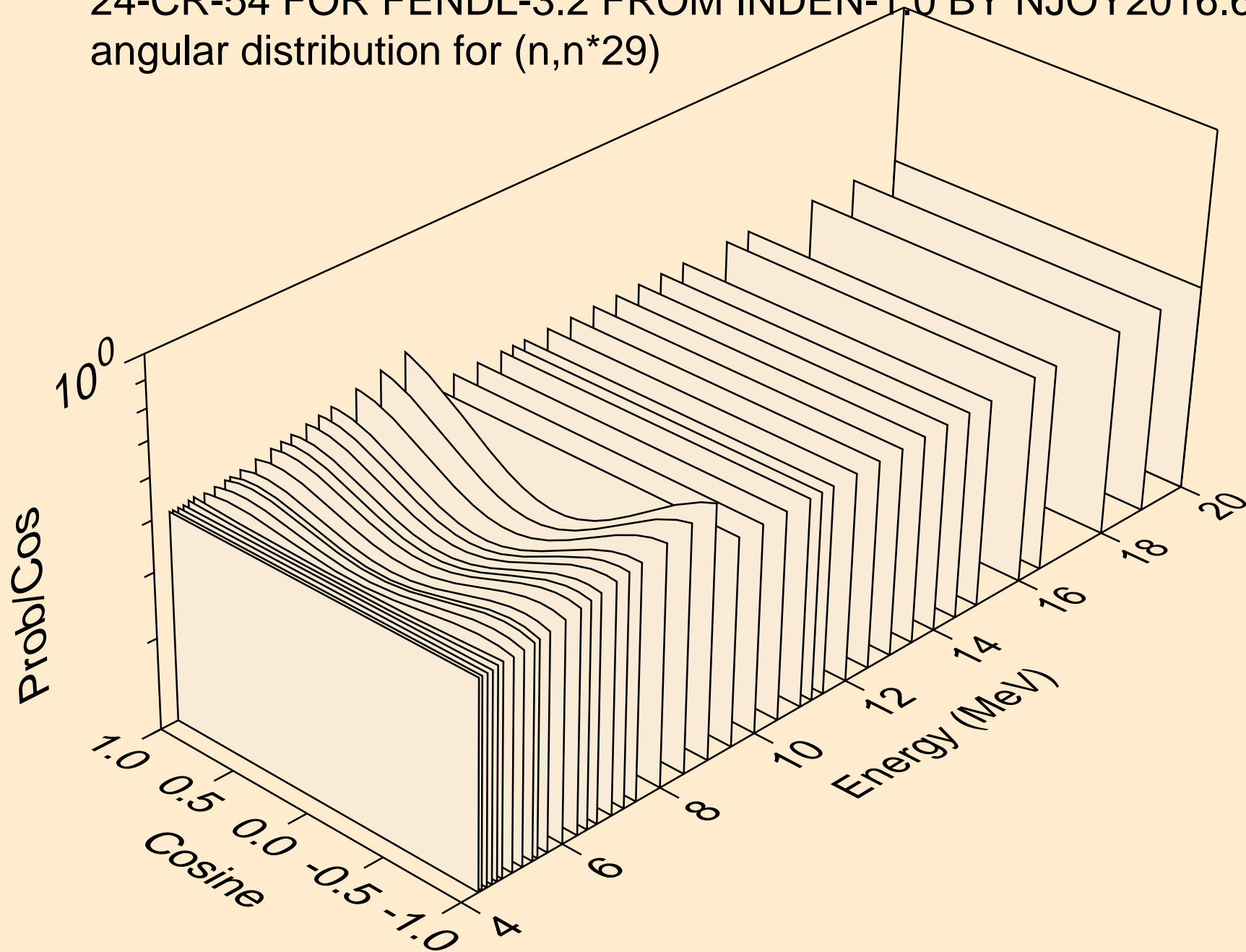

24-CR-54 FOR FENDL-3.2 FROM INDEN-1.0 BY NJOY2016.60+ OI
angular distribution for (n,n*29)

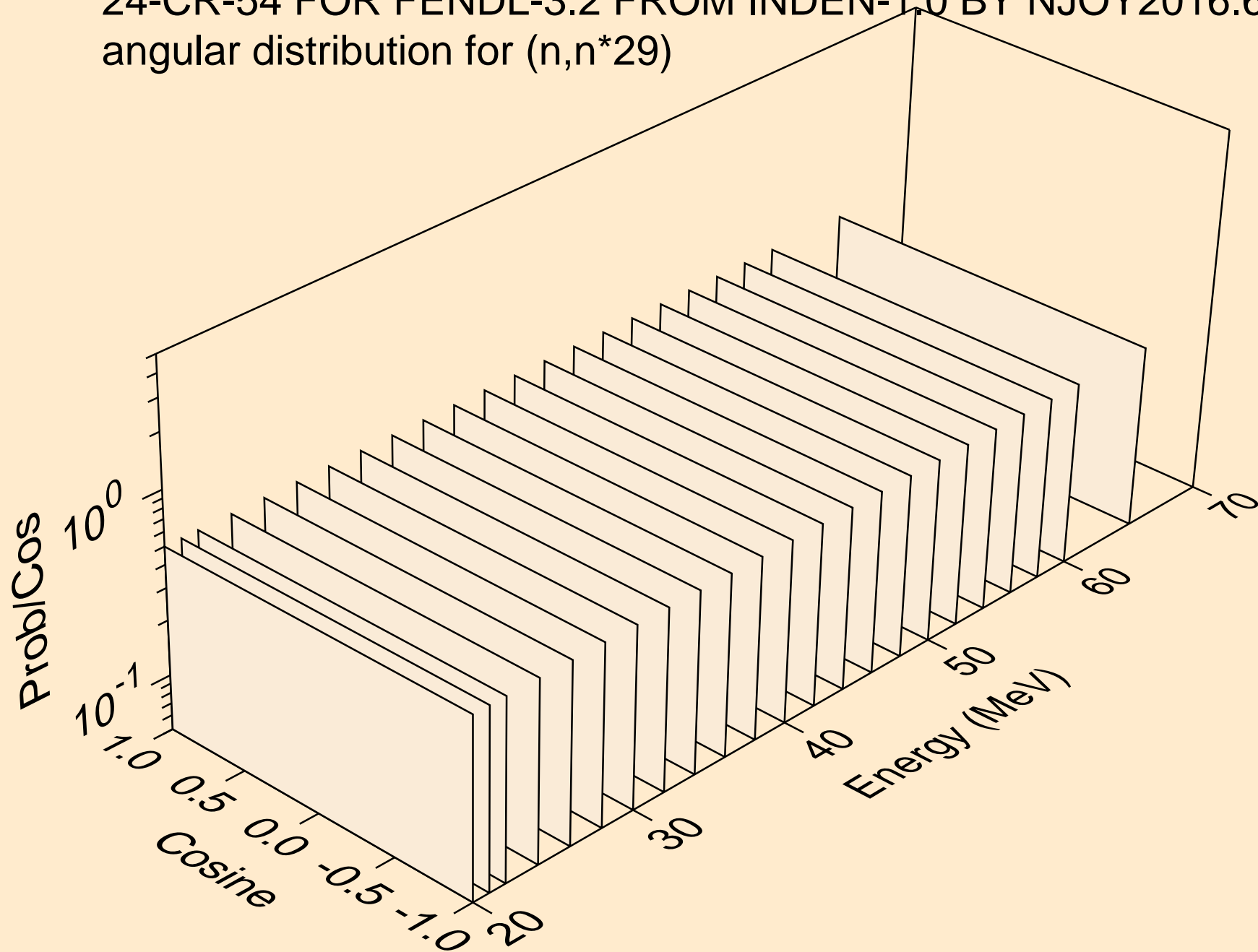

24-CR-54 FOR FENDL-3.2 FROM INDEN-1.0 BY NJOY2016.60+ OI
angular distribution for (n,n*30)

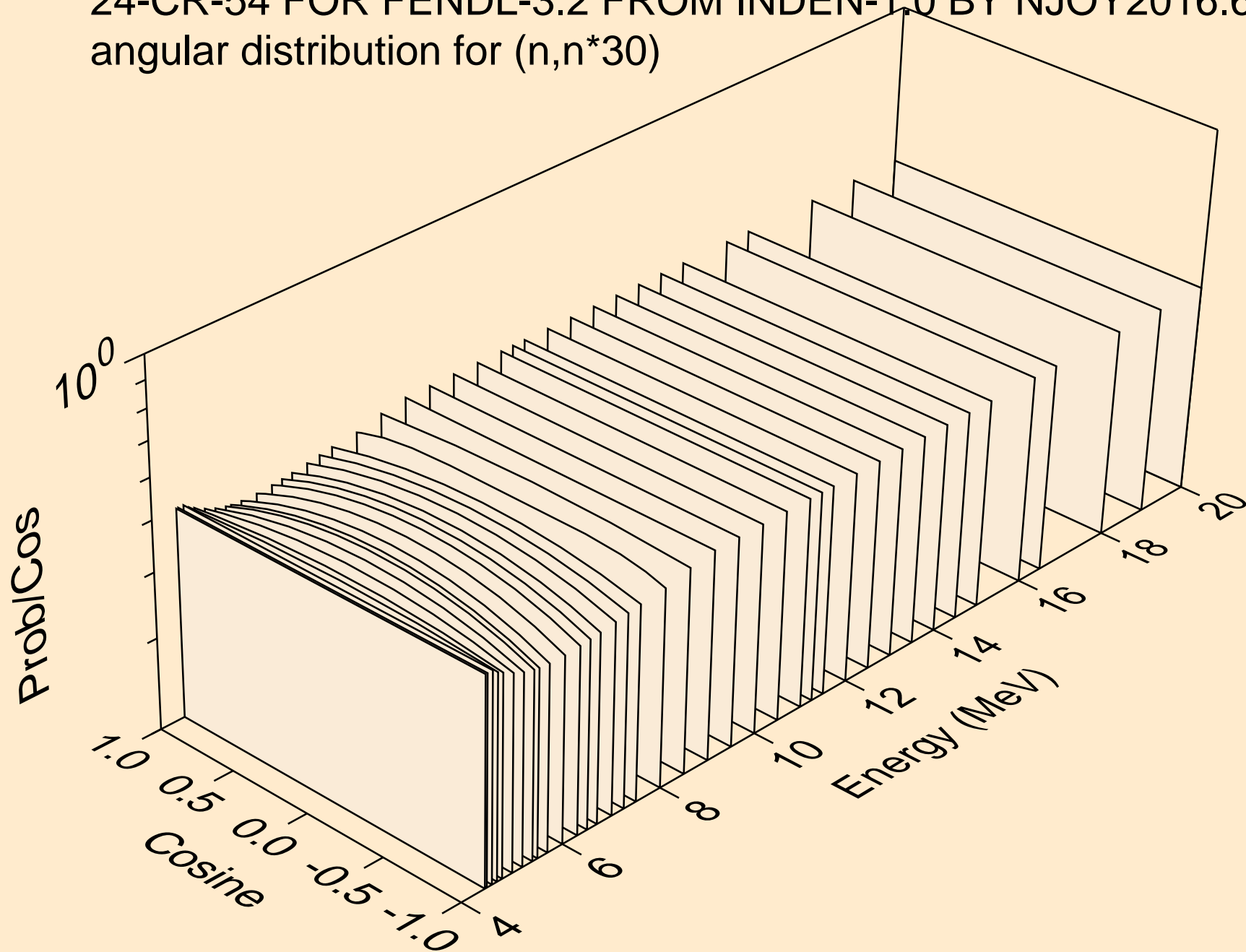

24-CR-54 FOR FENDL-3.2 FROM INDEN-1.0 BY NJOY2016.60+ OI
angular distribution for (n,n*30)

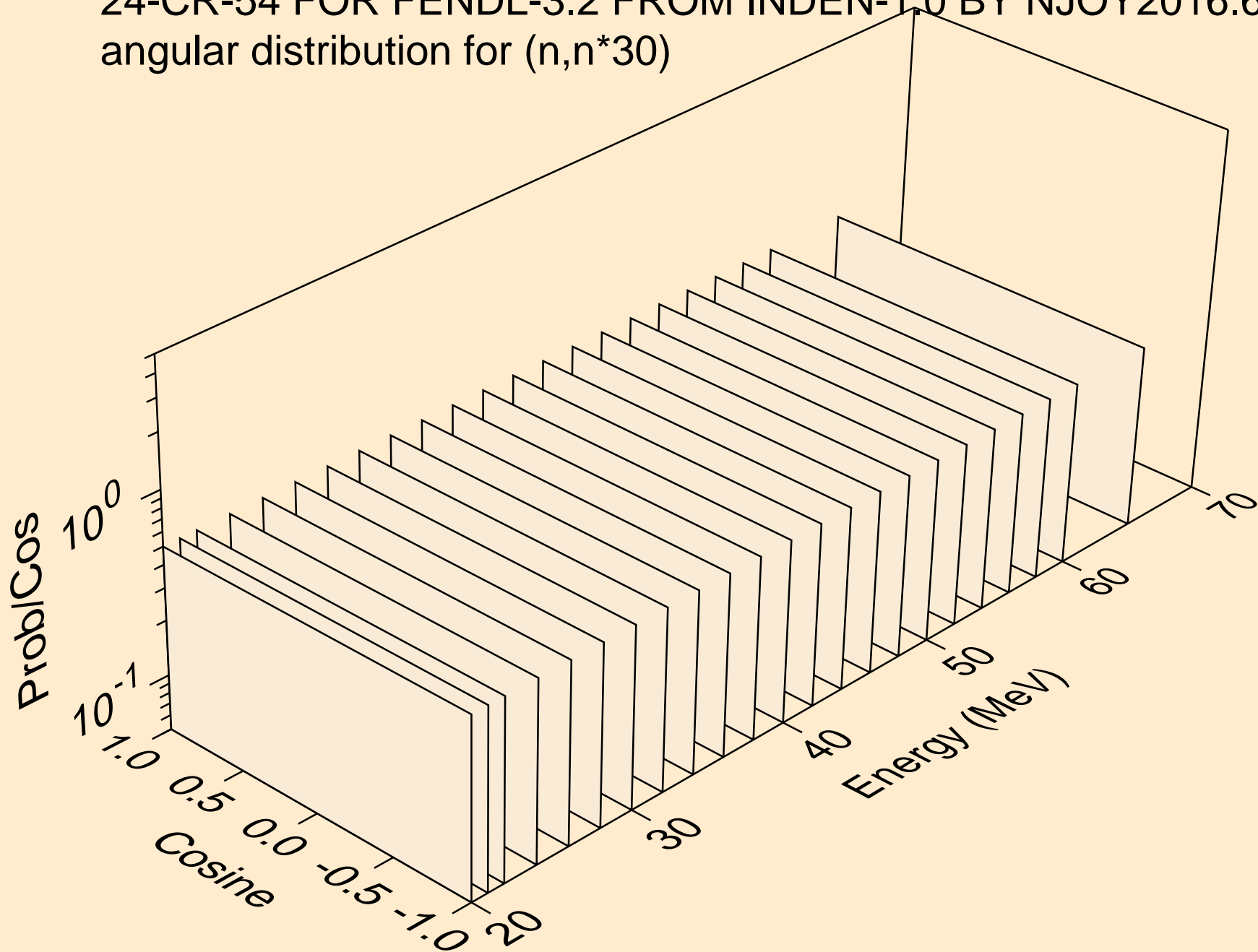

24-CR-54 FOR FENDL-3.2 FROM INDEN-1.0 BY NJOY2016.60+ OI
angular distribution for (n,n*31)

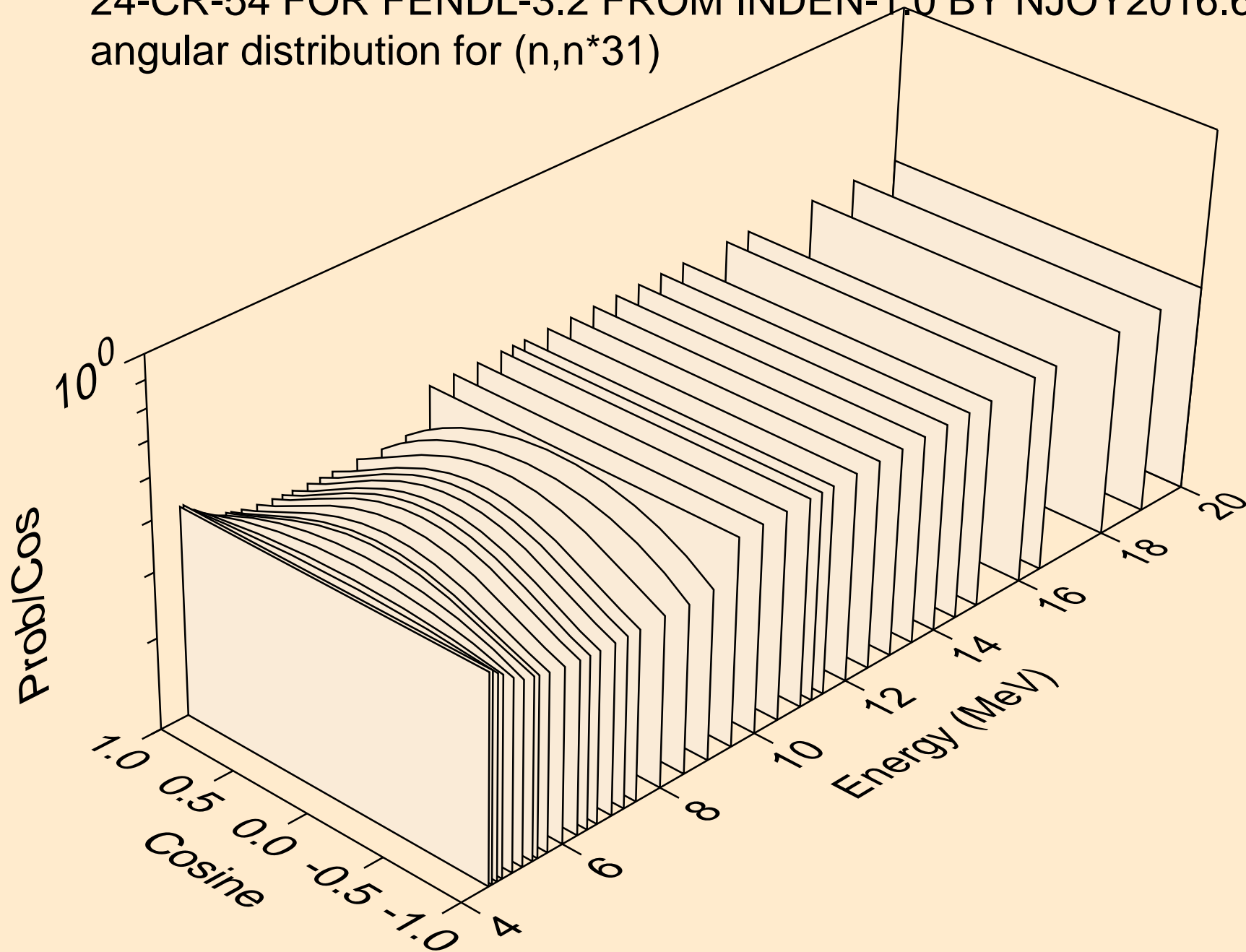

24-CR-54 FOR FENDL-3.2 FROM INDEN-1.0 BY NJOY2016.60+ OI
angular distribution for (n,n*31)

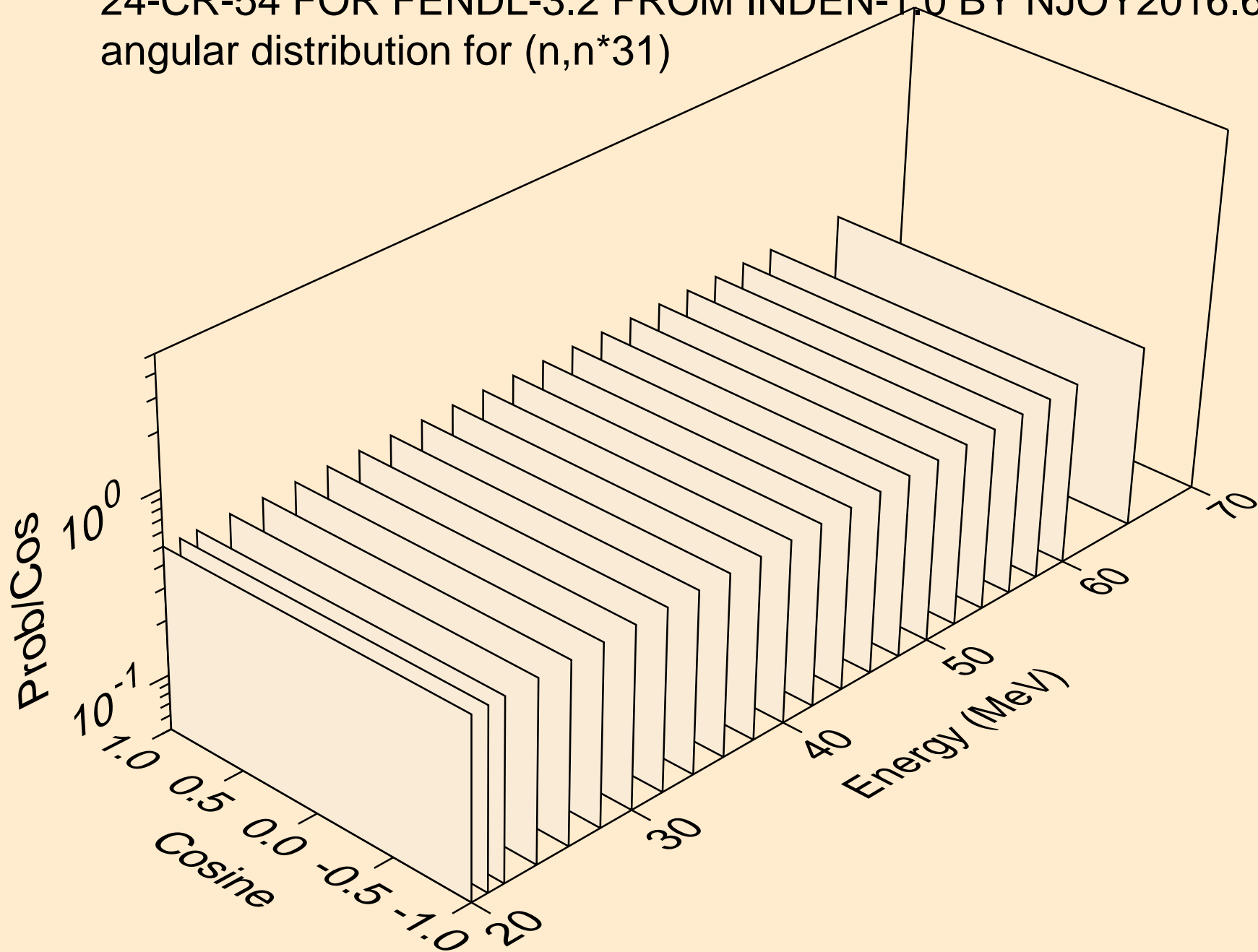

24-CR-54 FOR FENDL-3.2 FROM INDEN-1.0 BY NJOY2016.60+ OI
angular distribution for (n,n*32)

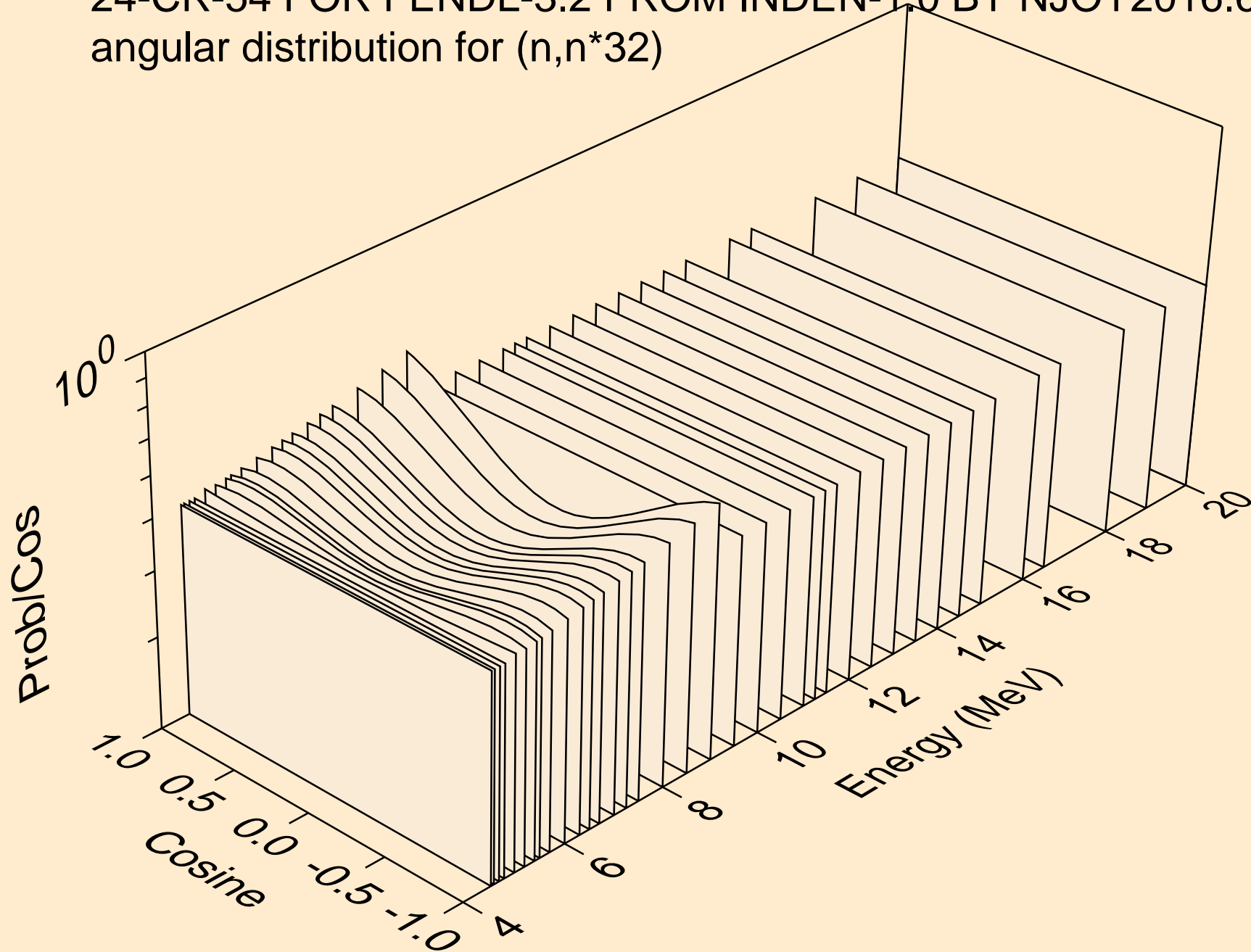

24-CR-54 FOR FENDL-3.2 FROM INDEN-1.0 BY NJOY2016.60+ OI
angular distribution for (n,n*32)

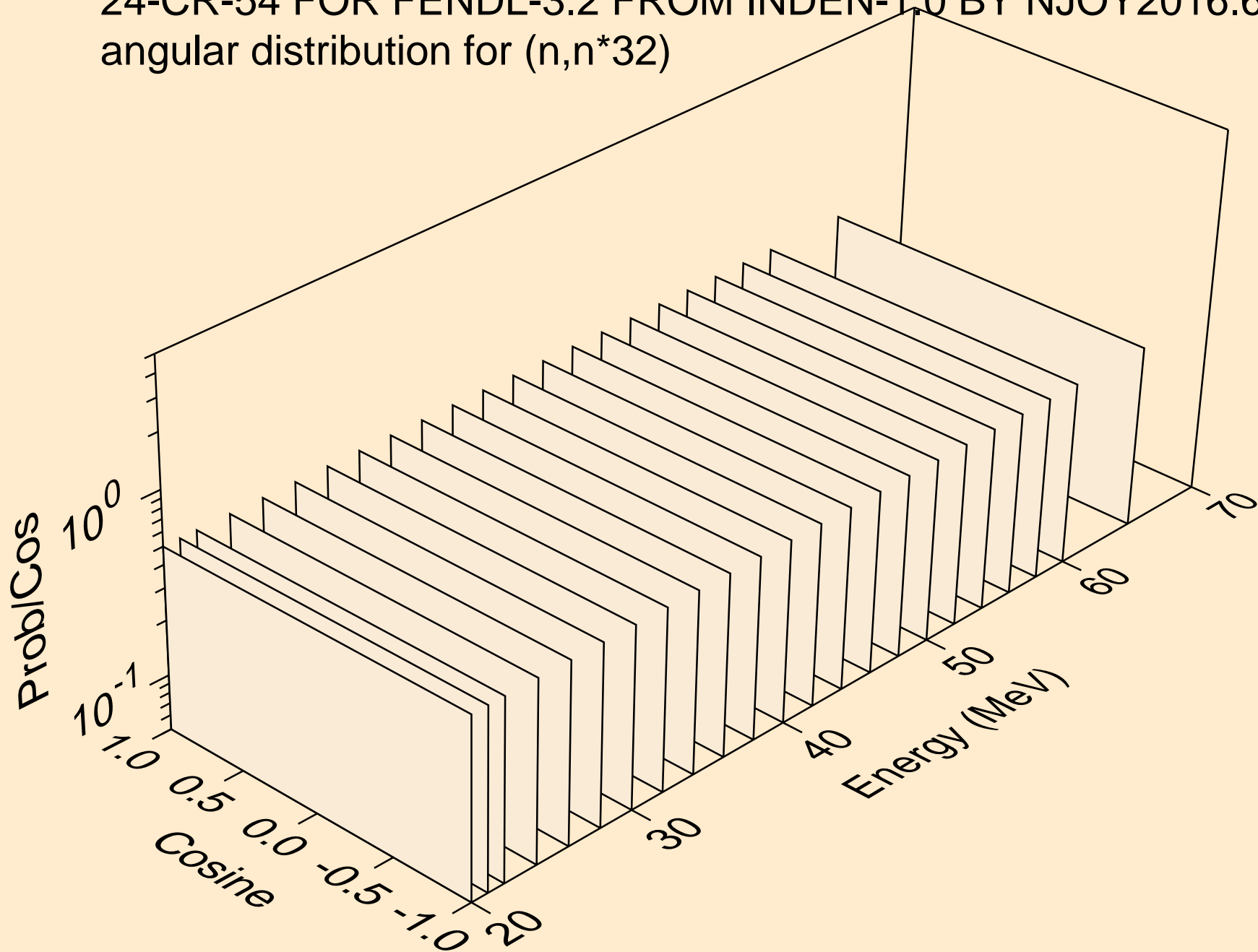

24-CR-54 FOR FENDL-3.2 FROM INDEN-1.0 BY NJOY2016.60+ OI
angular distribution for (n,n*33)

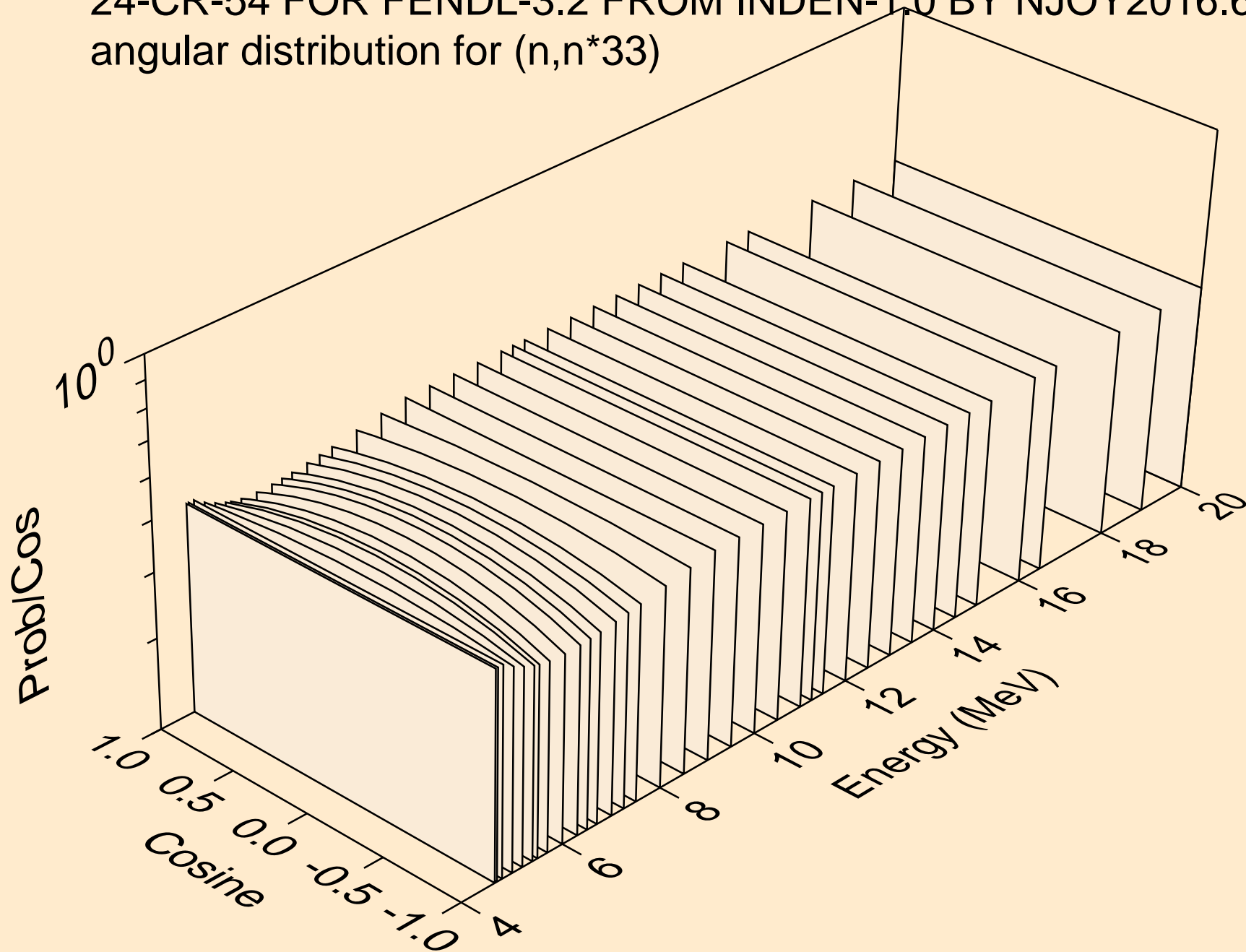

24-CR-54 FOR FENDL-3.2 FROM INDEN-1.0 BY NJOY2016.60+ OI
angular distribution for (n,n*33)

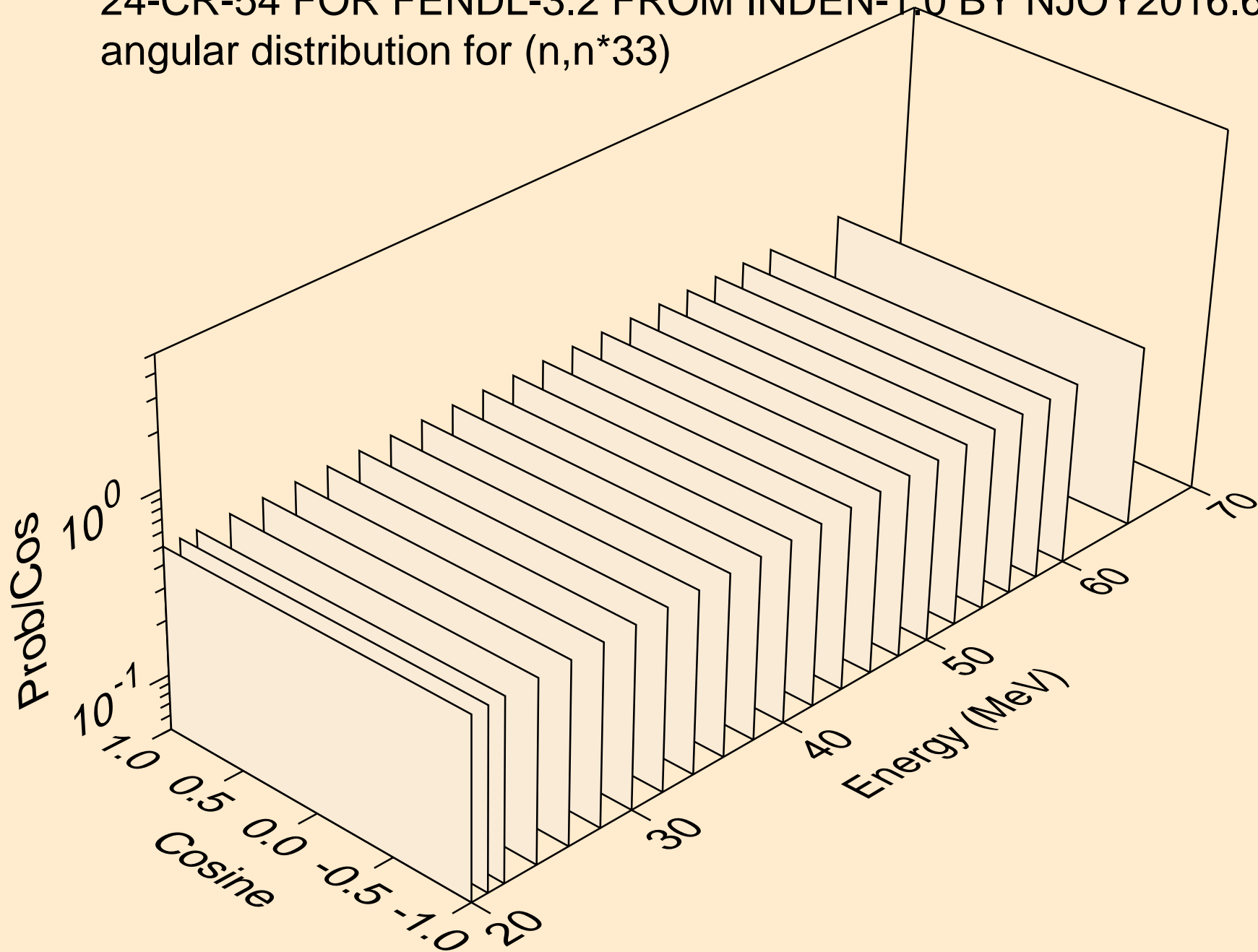

24-CR-54 FOR FENDL-3.2 FROM INDEN-1.0 BY NJOY2016.60+ OI
angular distribution for (n,n*34)

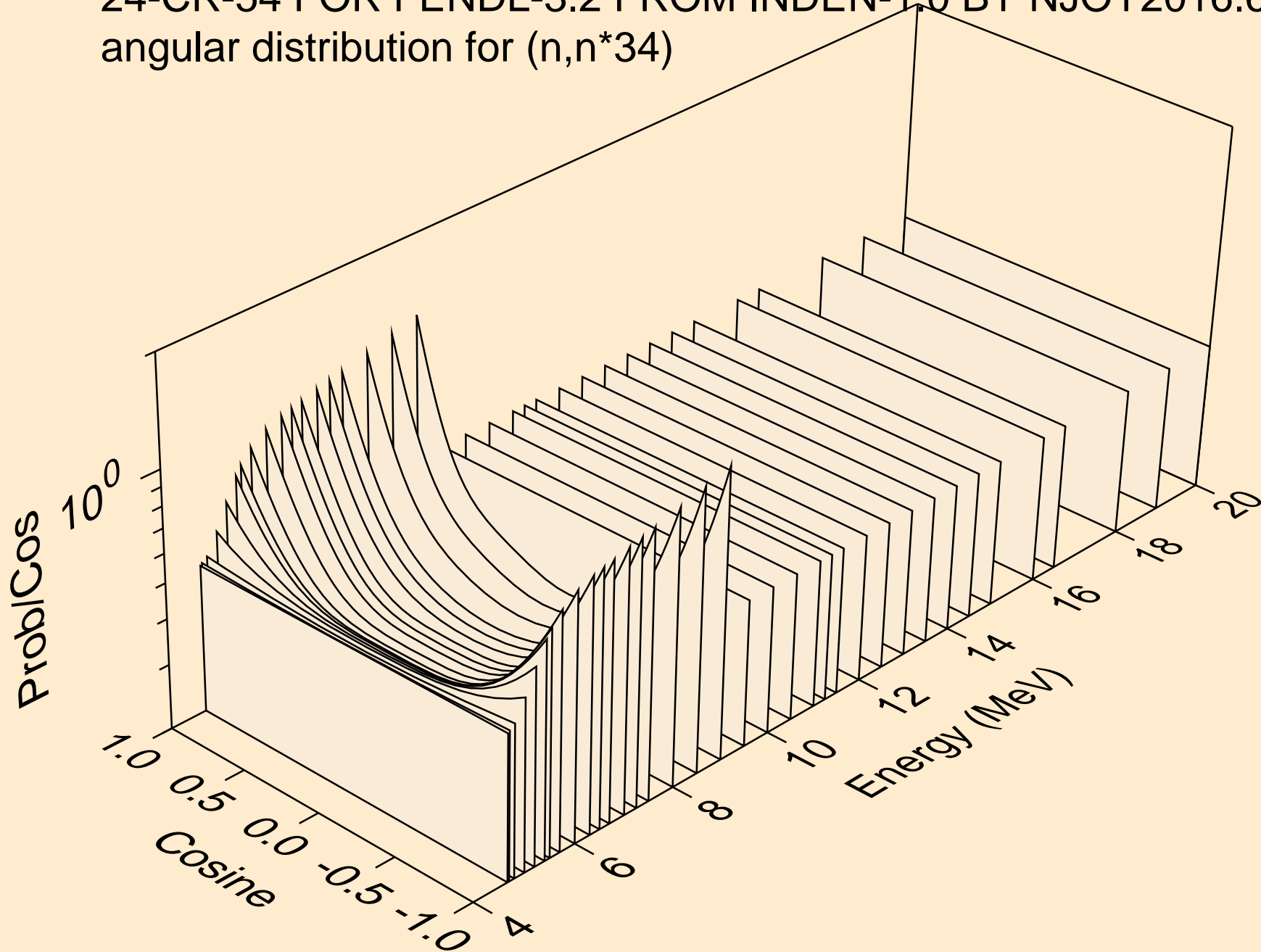

24-CR-54 FOR FENDL-3.2 FROM INDEN-1.0 BY NJOY2016.60+ OI
angular distribution for (n,n*34)

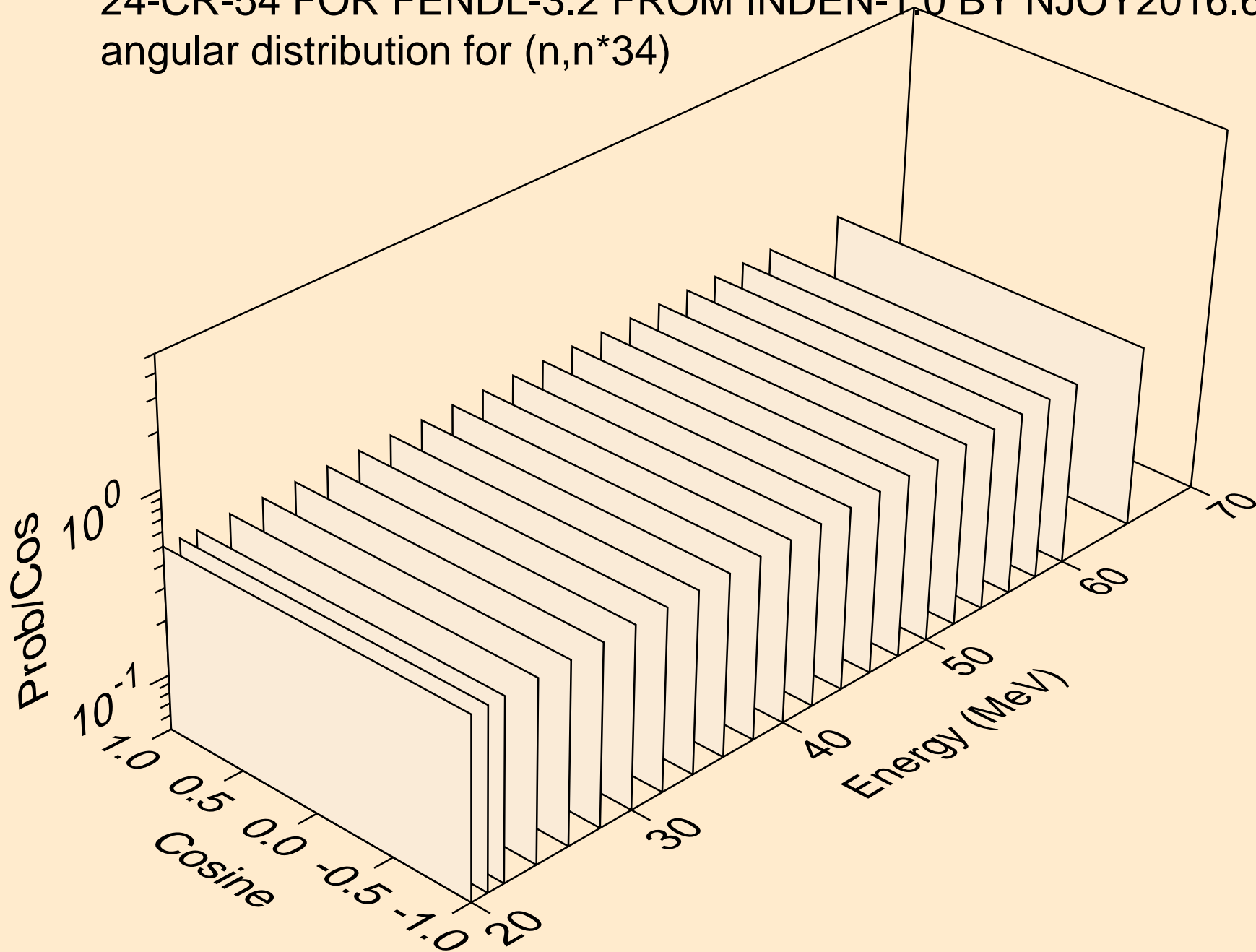

24-CR-54 FOR FENDL-3.2 FROM INDEN-1.0 BY NJOY2016.60+ OI
angular distribution for (n,n*35)

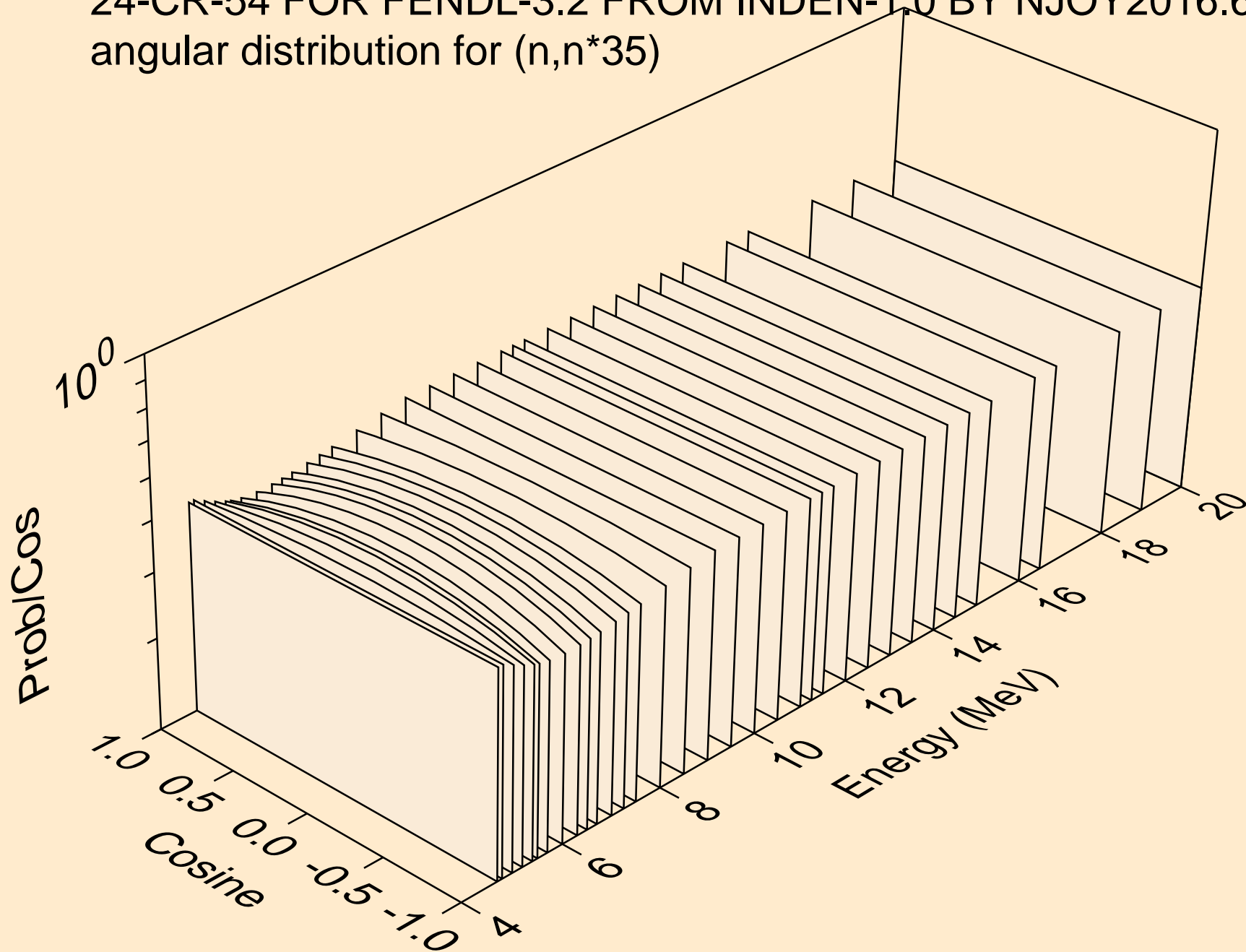

24-CR-54 FOR FENDL-3.2 FROM INDEN-1.0 BY NJOY2016.60+ OI
angular distribution for (n,n*35)

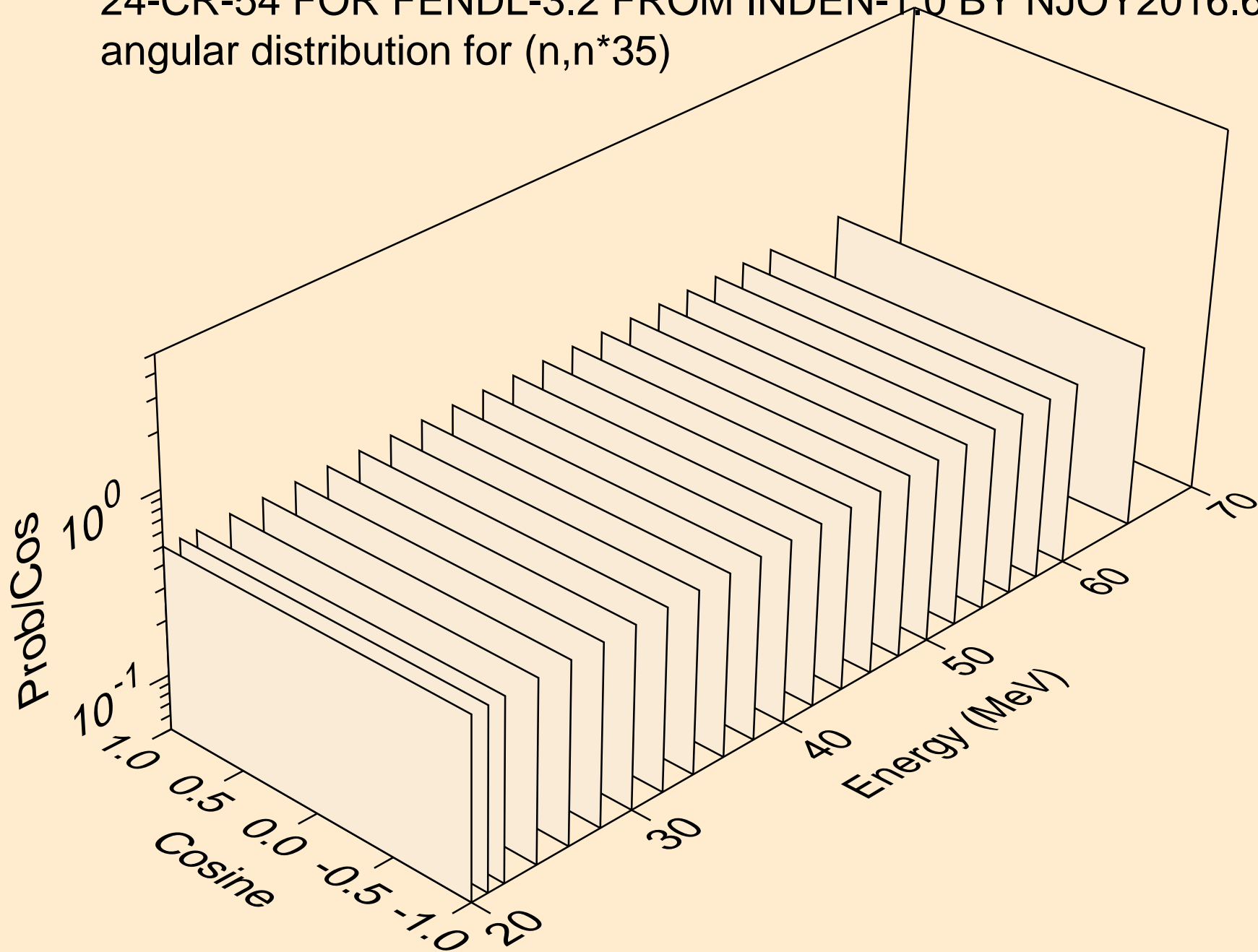

24-CR-54 FOR FENDL-3.2 FROM INDEN-1.0 BY NJOY2016.60+ OI
angular distribution for (n,n*36)

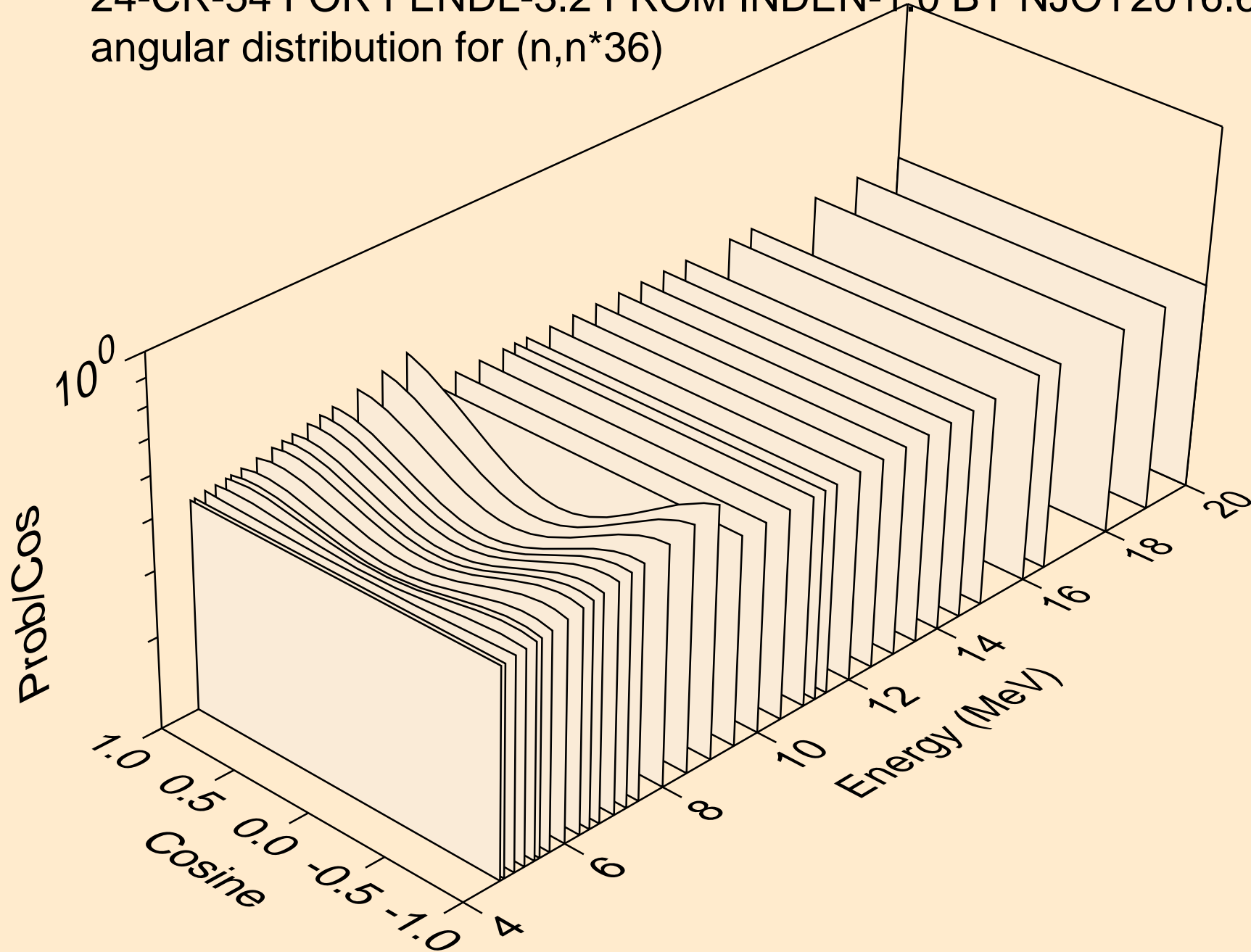

24-CR-54 FOR FENDL-3.2 FROM INDEN-1.0 BY NJOY2016.60+ OI
angular distribution for (n,n*36)

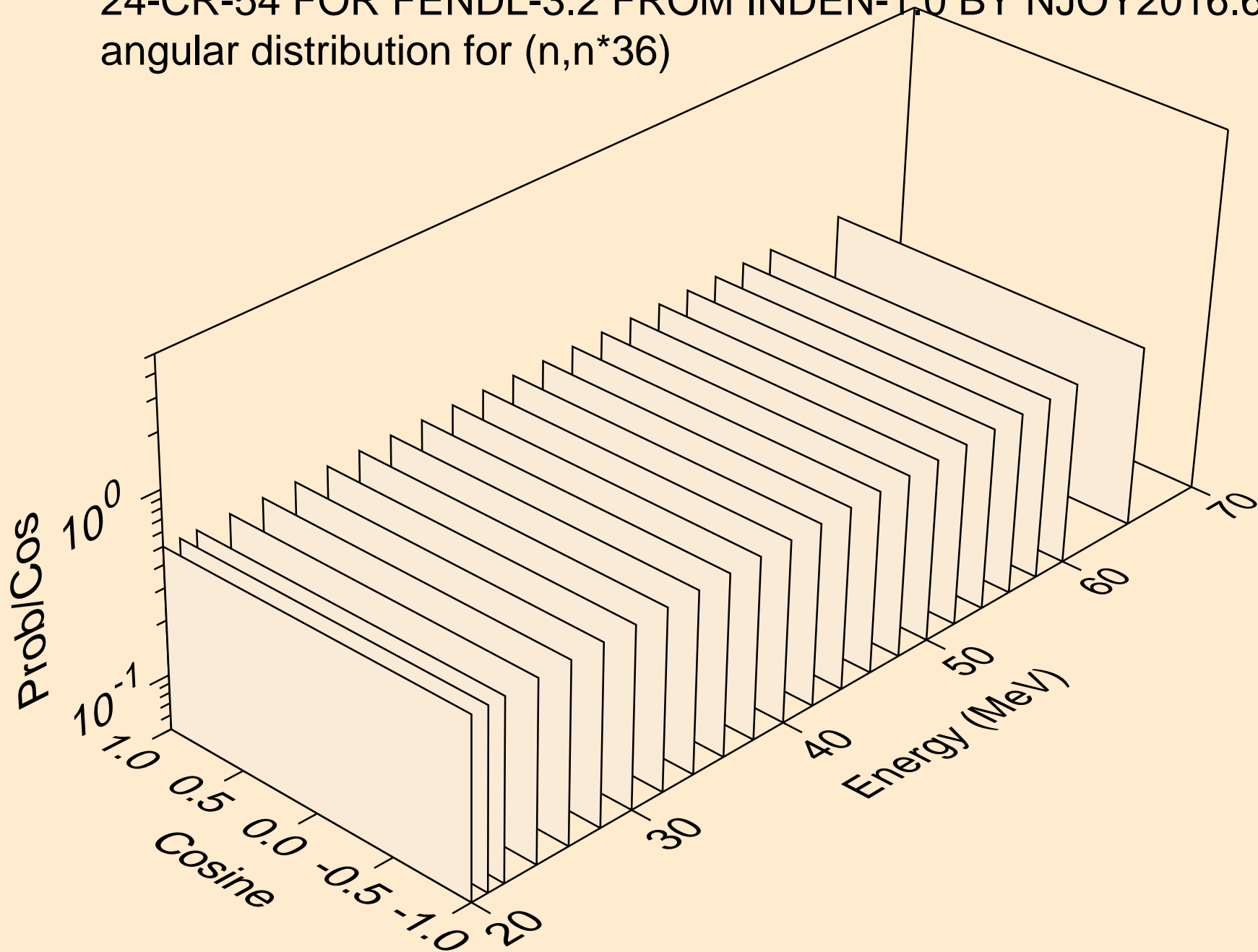

24-CR-54 FOR FENDL-3.2 FROM INDEN-1.0 BY NJOY2016.60+ OI
angular distribution for (n,n*37)

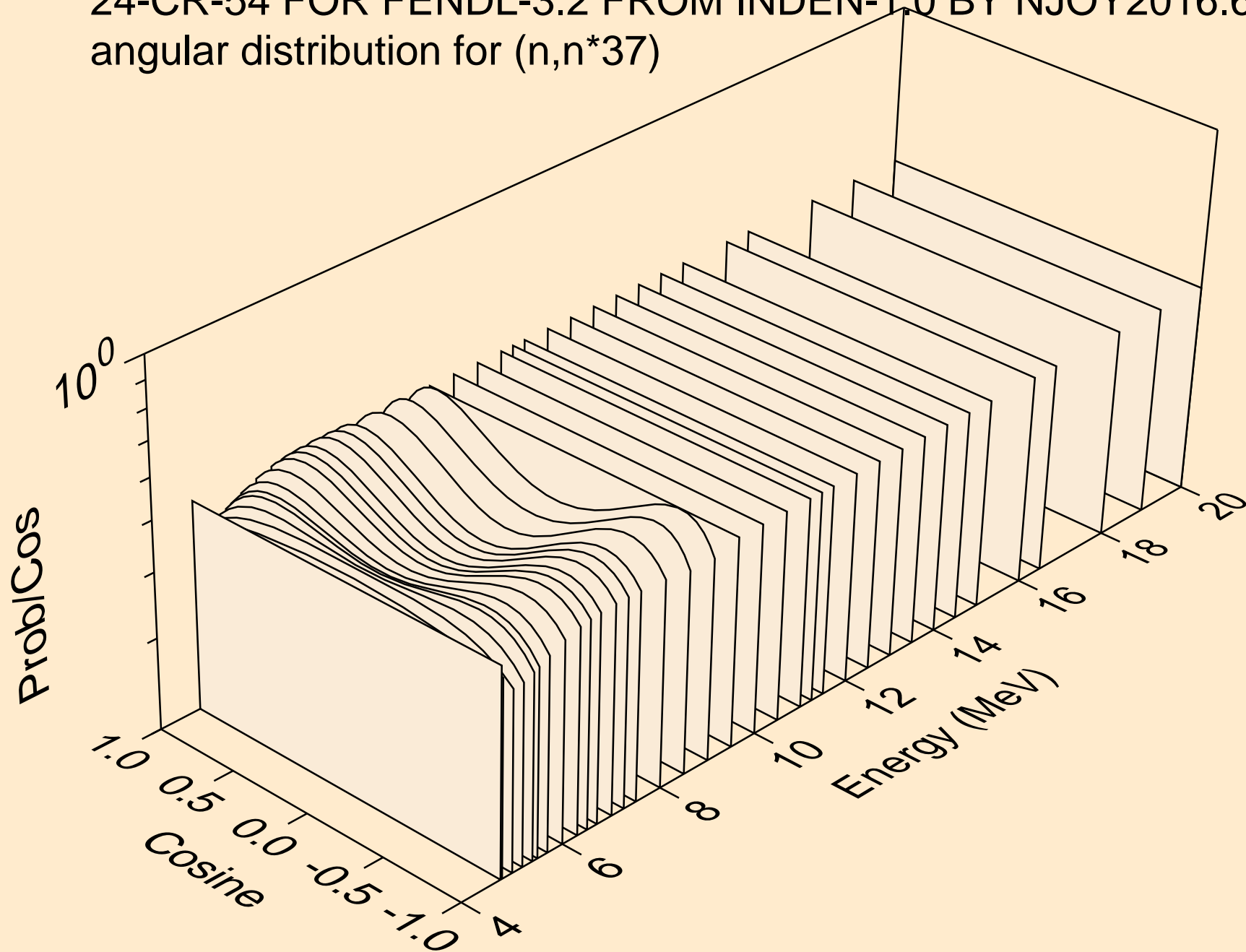

24-CR-54 FOR FENDL-3.2 FROM INDEN-1.0 BY NJOY2016.60+ OI
angular distribution for (n,n*37)

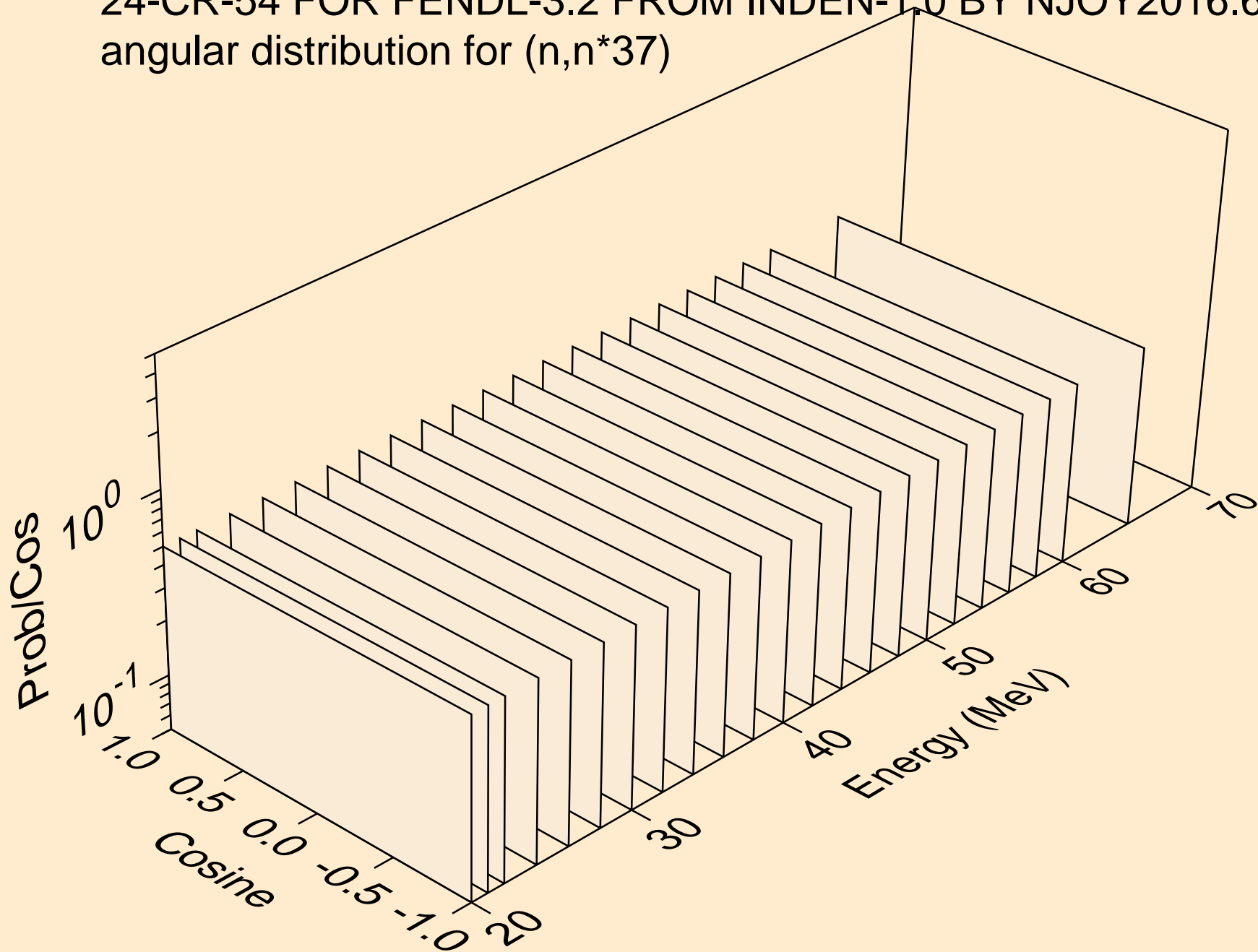

24-CR-54 FOR FENDL-3.2 FROM INDEN-1.0 BY NJOY2016.60+ OI
angular distribution for (n,n*38)

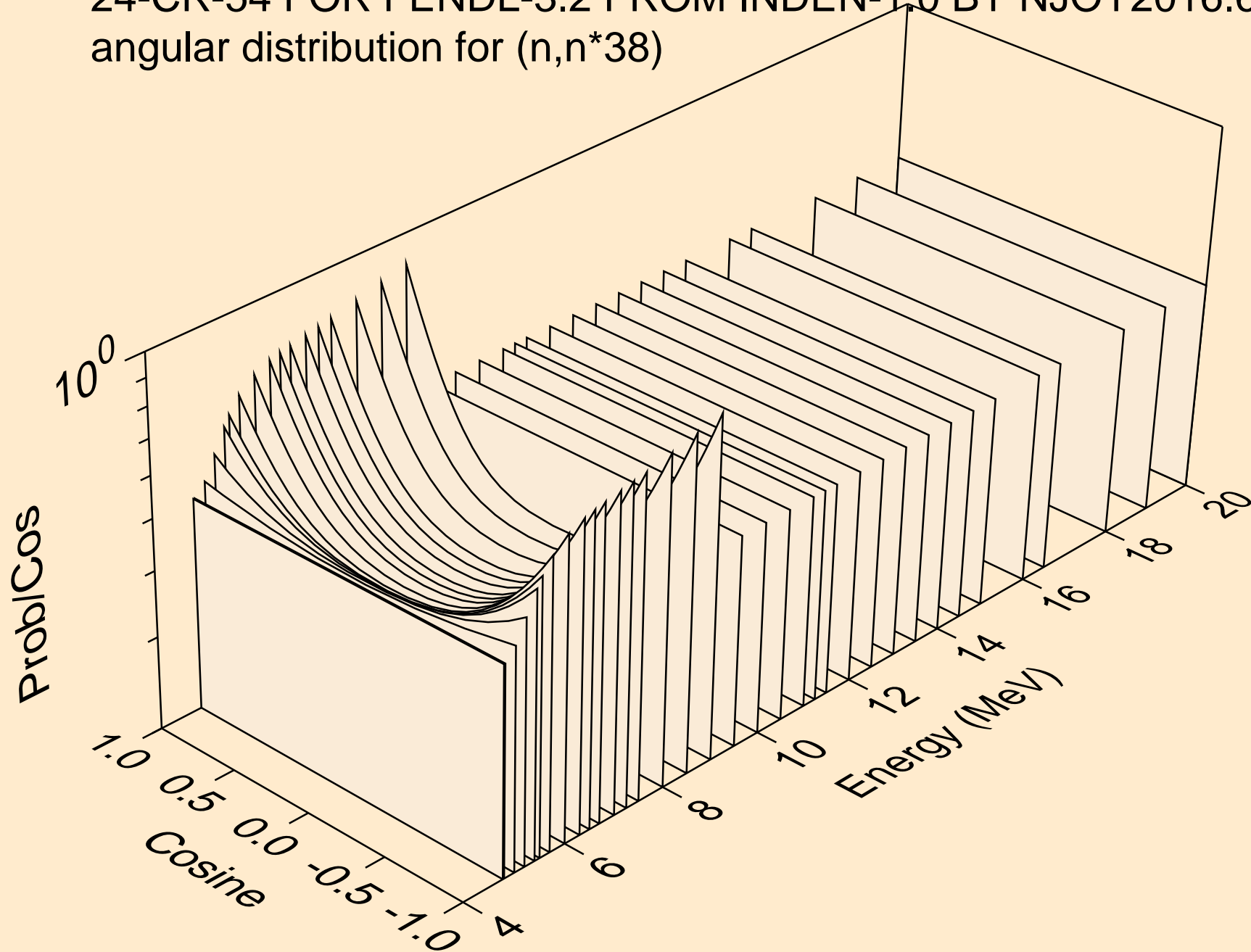

24-CR-54 FOR FENDL-3.2 FROM INDEN-1.0 BY NJOY2016.60+ OI
angular distribution for (n,n*38)

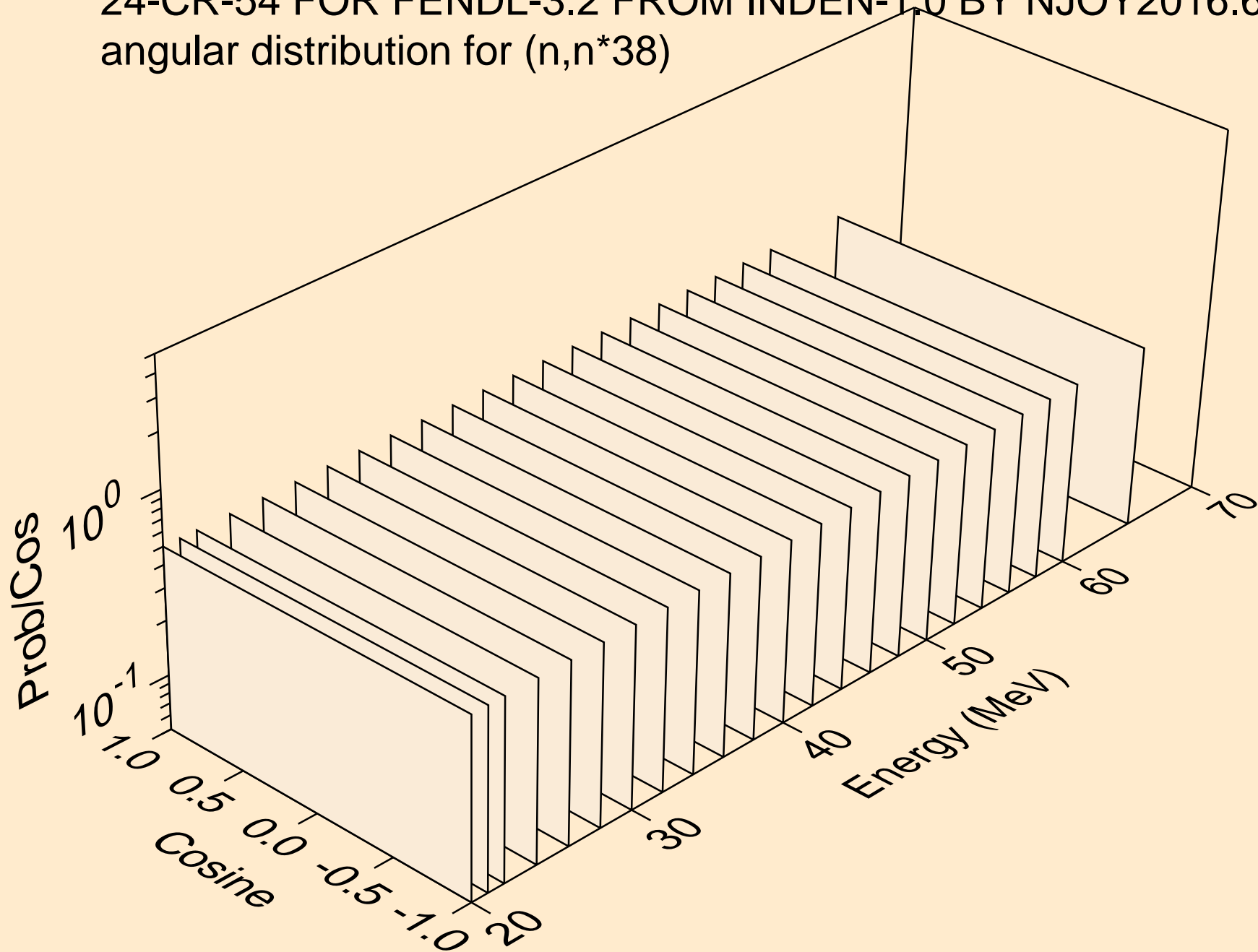

24-CR-54 FOR FENDL-3.2 FROM INDEN-1.0 BY NJOY2016.60+ OI
Neutron emission for (n,x)

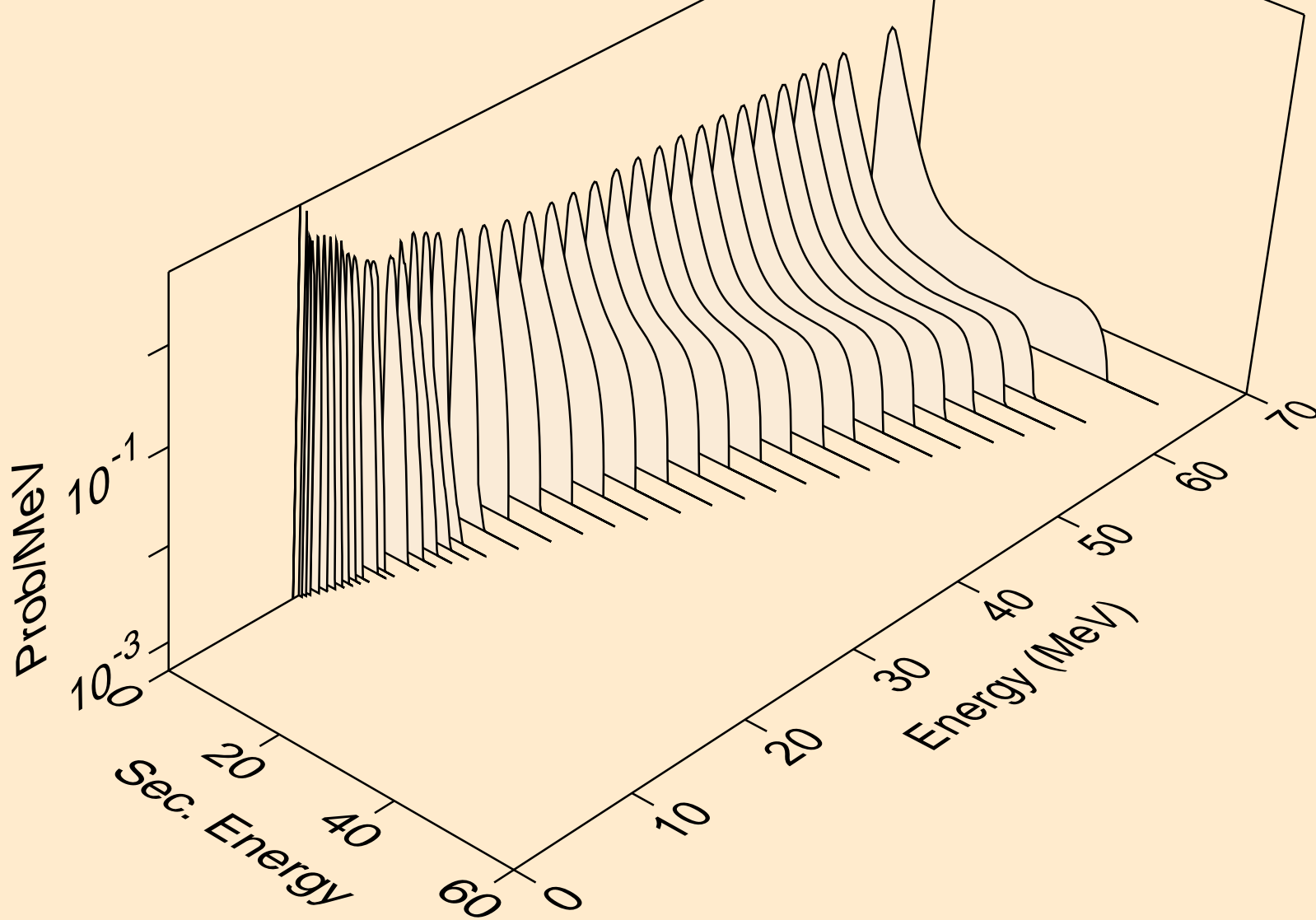

24-CR-54 FOR FENDL-3.2 FROM INDEN-1.0 BY NJOY2016.60+ OI
Neutron emission for (n,2n)

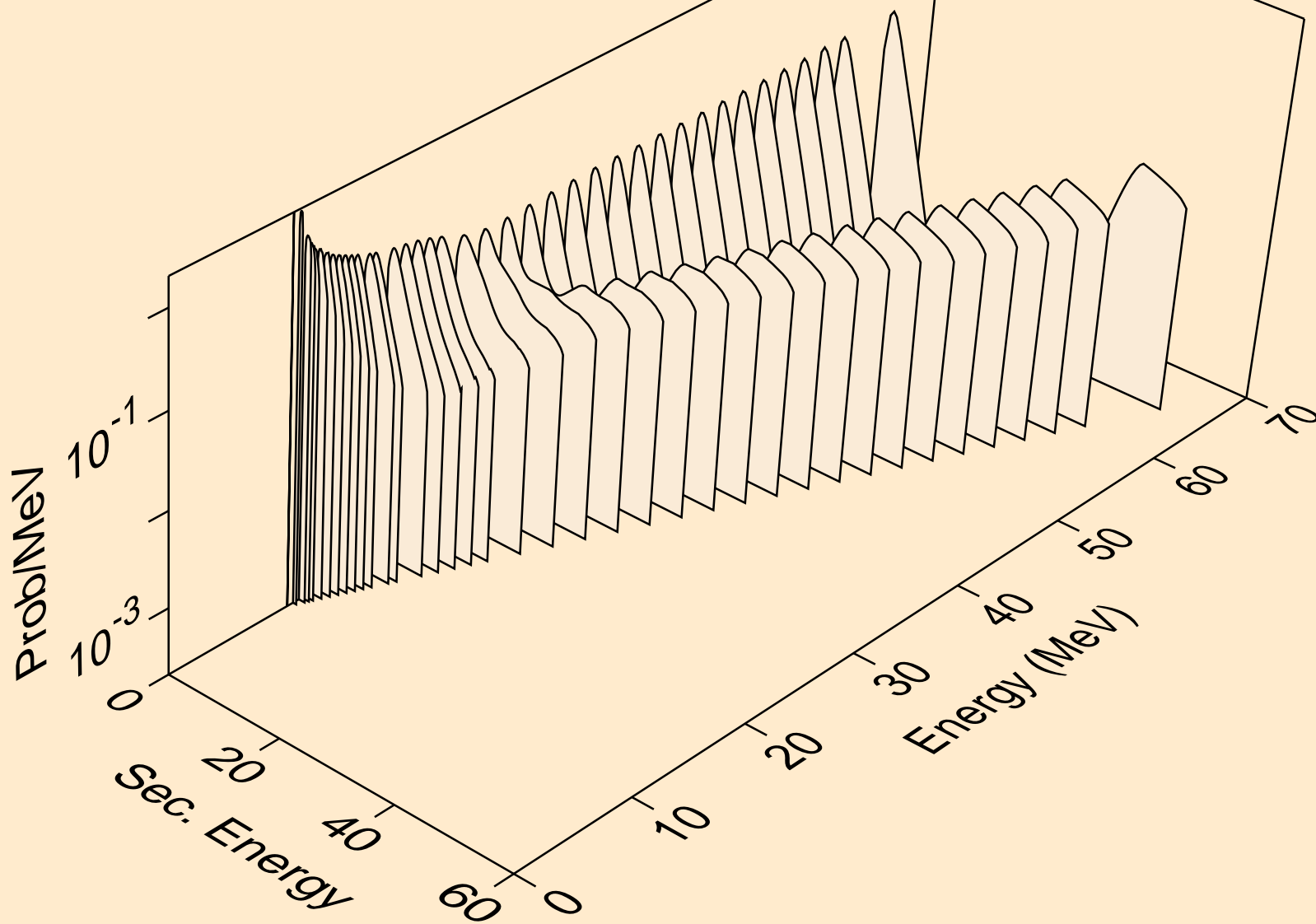

24-CR-54 FOR FENDL-3.2 FROM INDEN-1.0 BY NJOY2016.60+ OI
Neutron emission for (n,n*)p

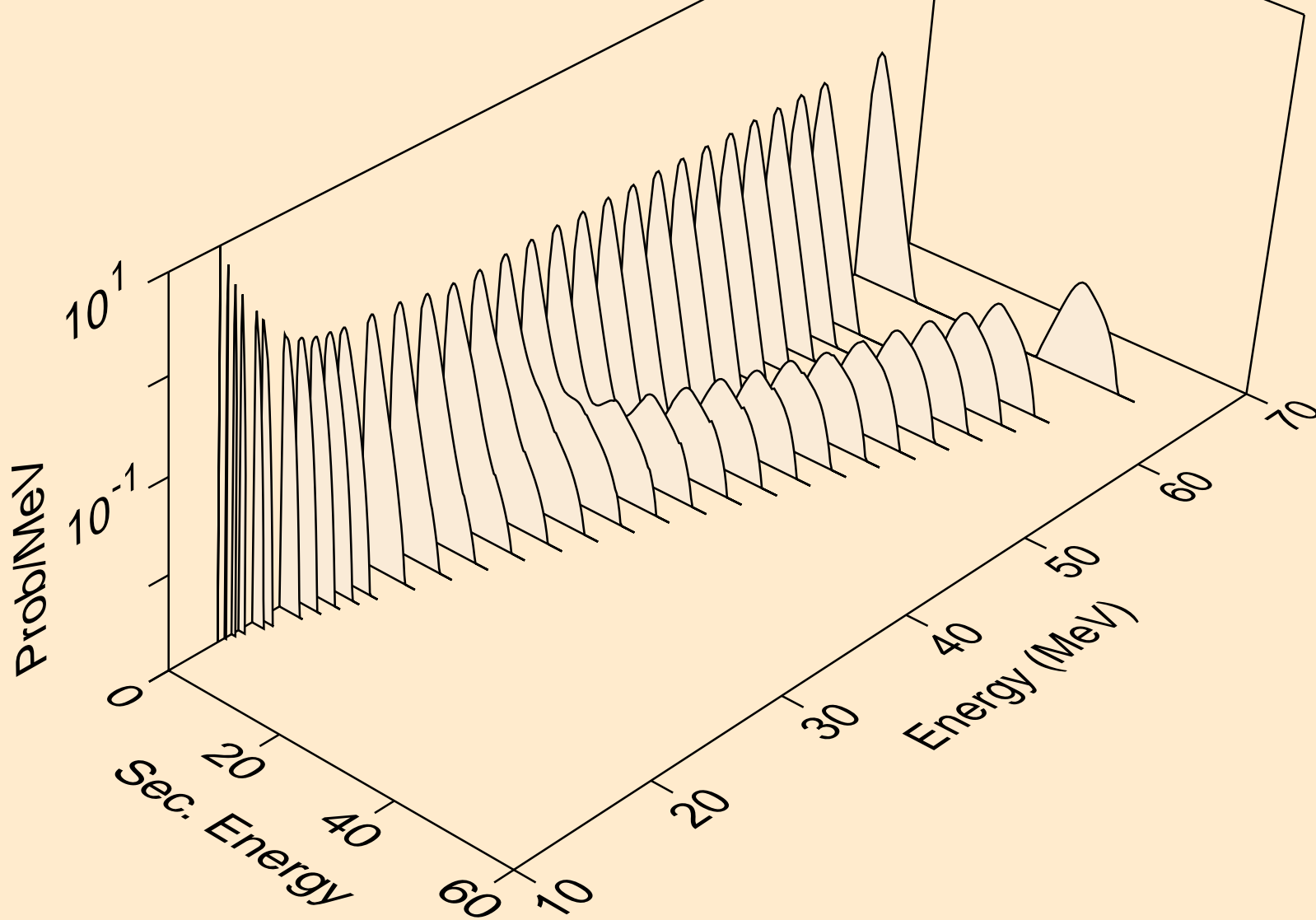

24-CR-54 FOR FENDL-3.2 FROM INDEN-1.0 BY NJOY2016.60+ OI
Neutron emission for (n,n*)d

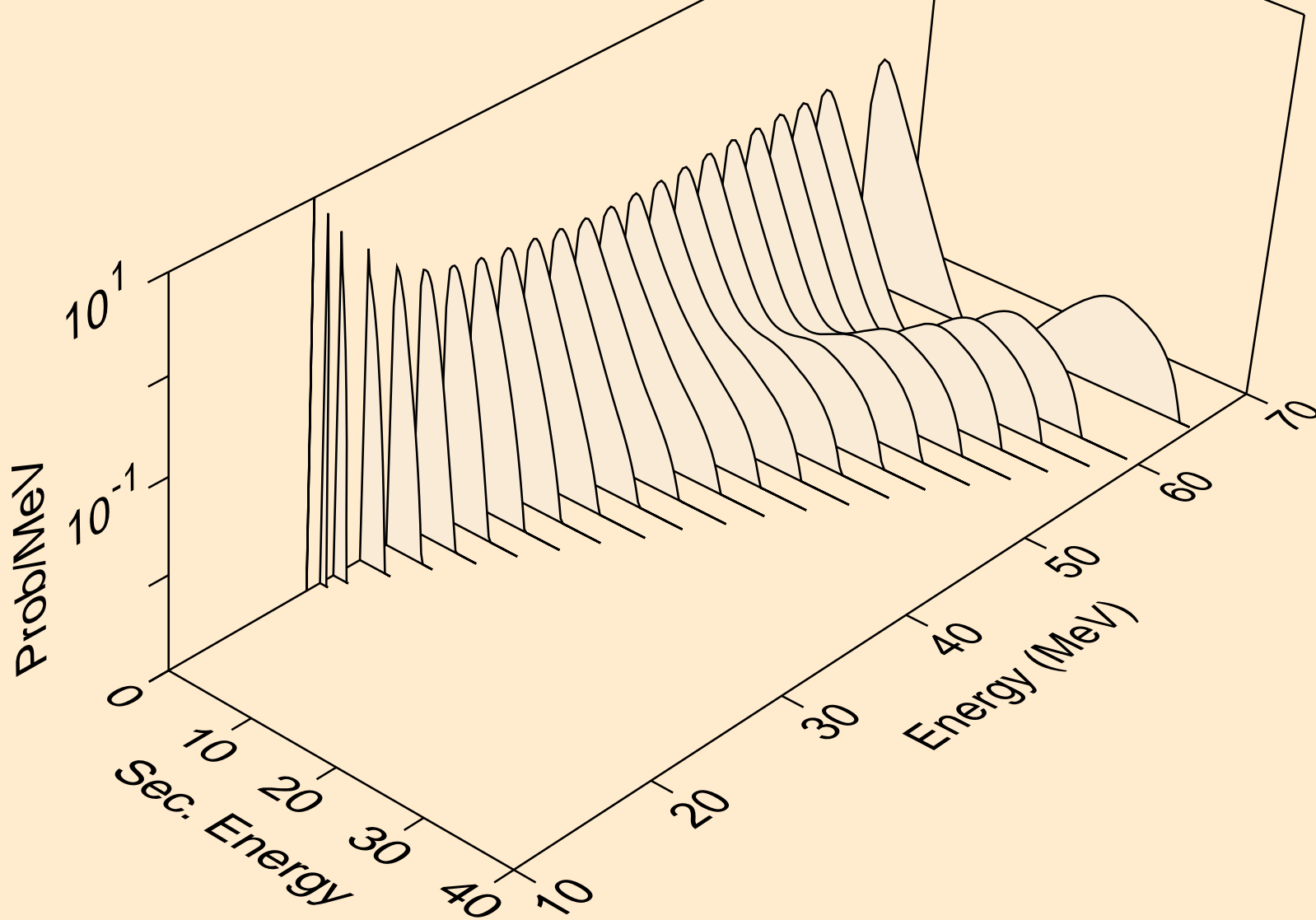

24-CR-54 FOR FENDL-3.2 FROM INDEN-1.0 BY NJOY2016.60+ OI
Neutron emission for (n,n*)he3

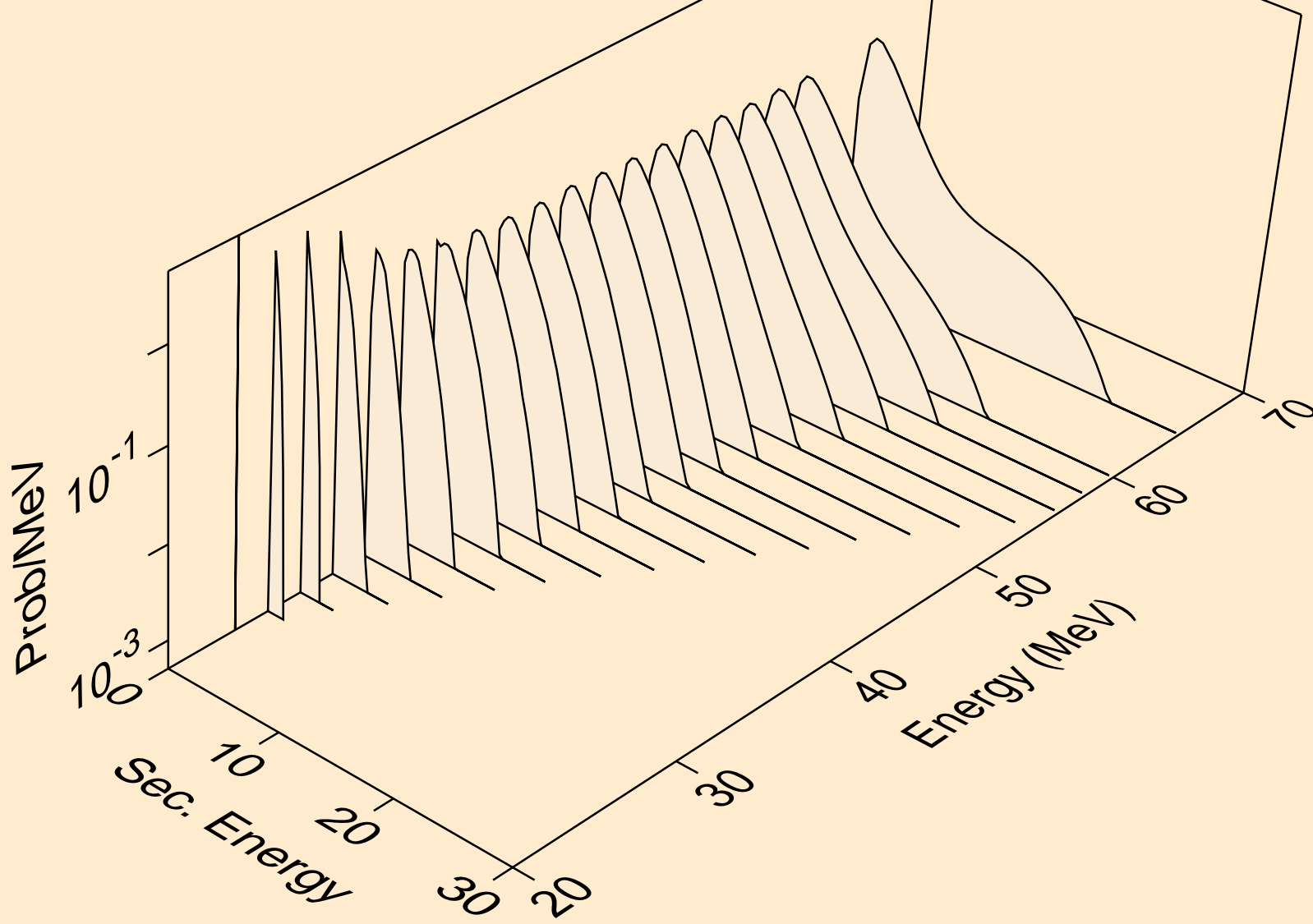

24-CR-54 FOR FENDL-3.2 FROM INDEN-1.0 BY NJOY2016.60+ OI
Neutron emission for (n,2np)

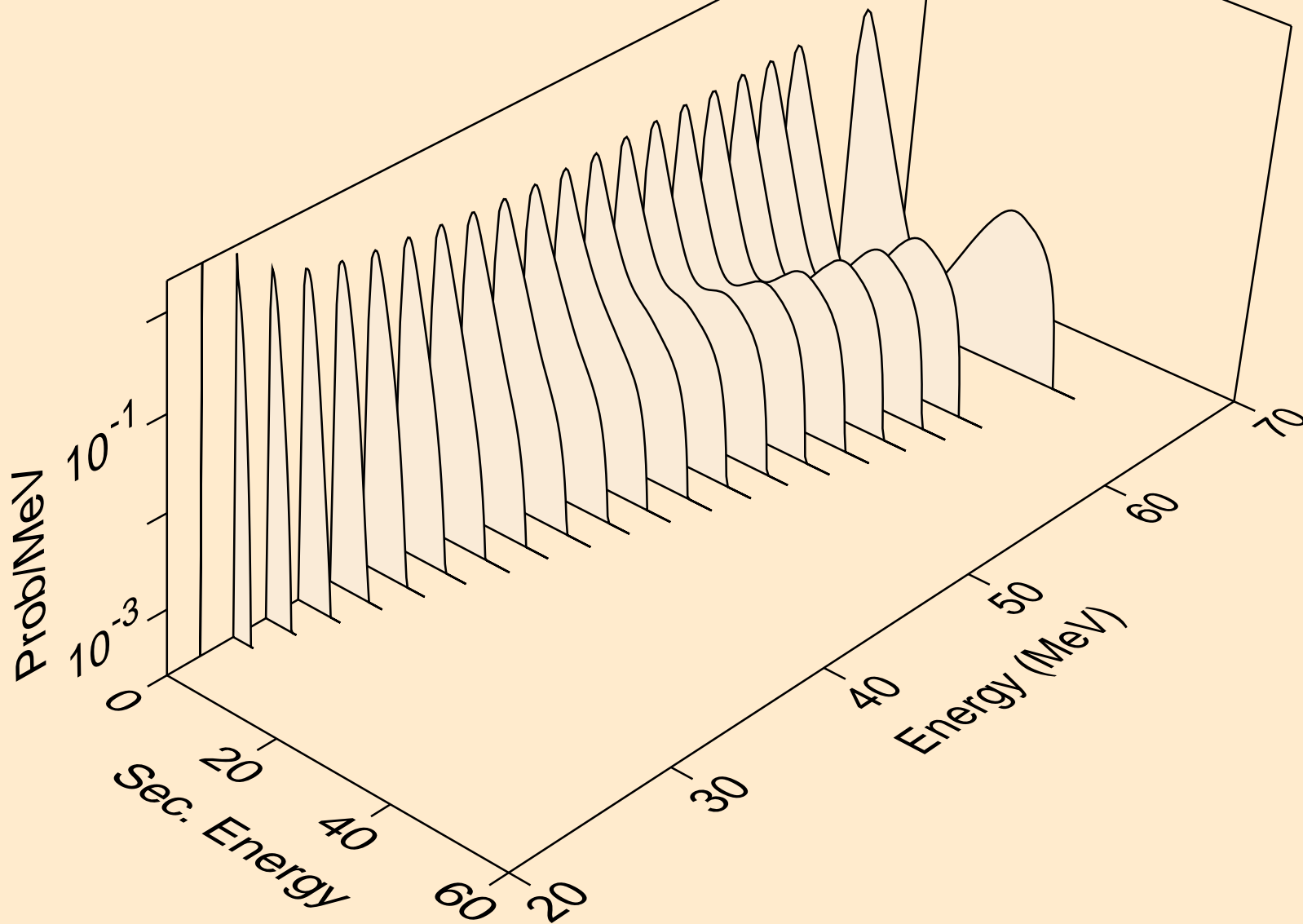

24-CR-54 FOR FENDL-3.2 FROM INDEN-1.0 BY NJOY2016.60+ OI
Neutron emission for (n,2np)

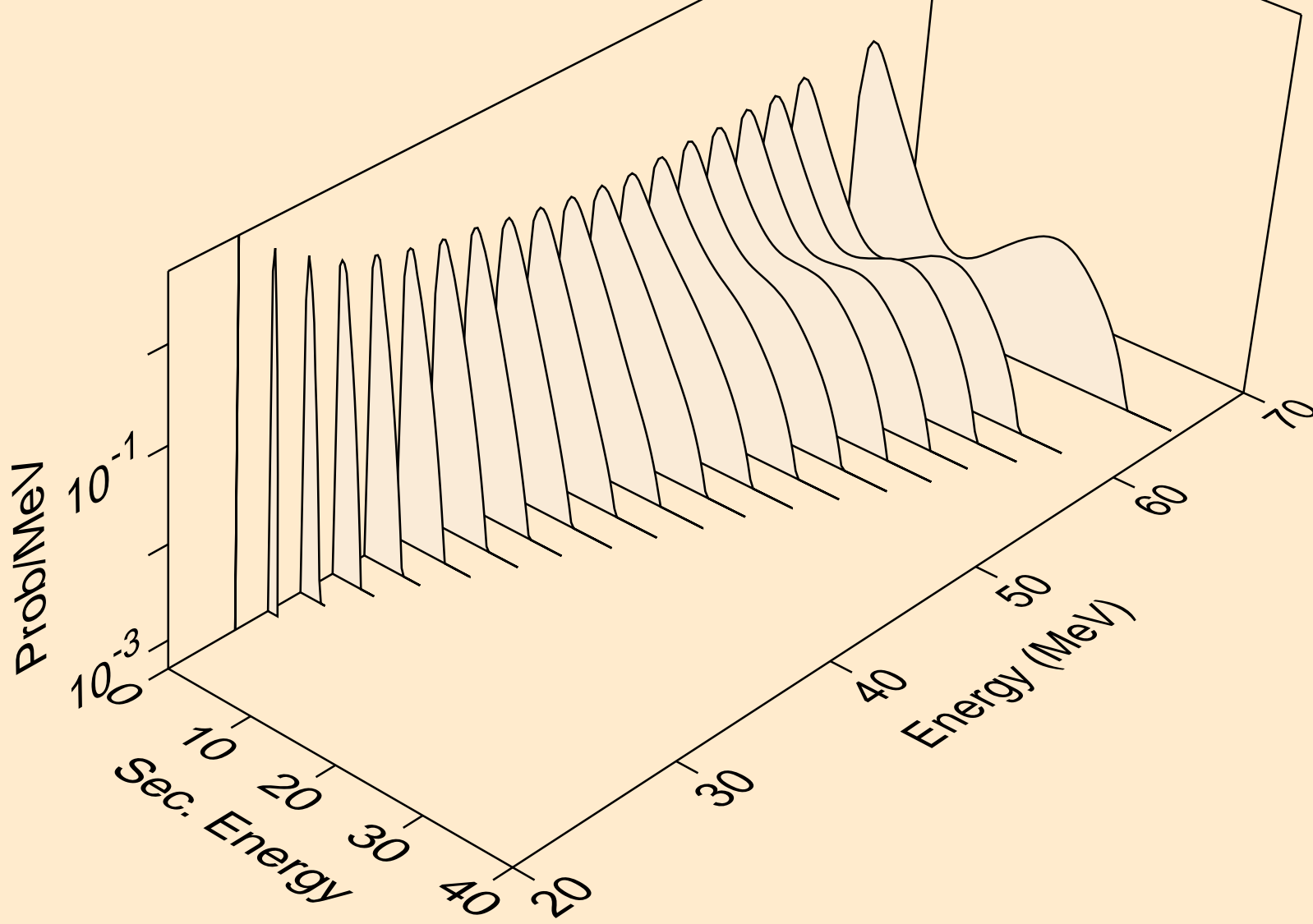

24-CR-54 FOR FENDL-3.2 FROM INDEN-1.0 BY NJOY2016.60+ OI
Neutron emission for (n,n*c)

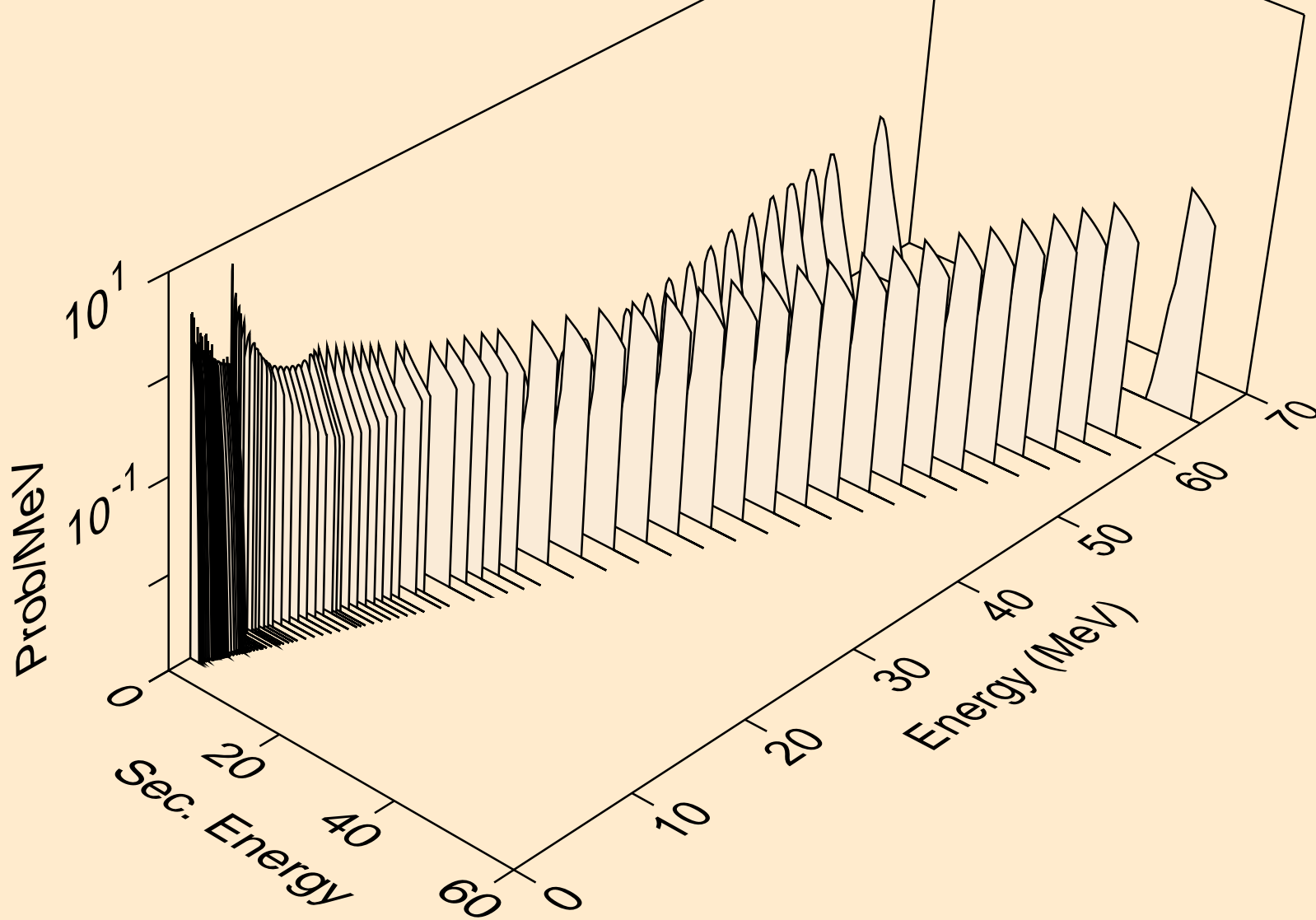

24-CR-54 FOR FENDL-3.2 FROM INDEN-1.0 BY NJOY2016.60+ OI
Photon emission for (n,x)

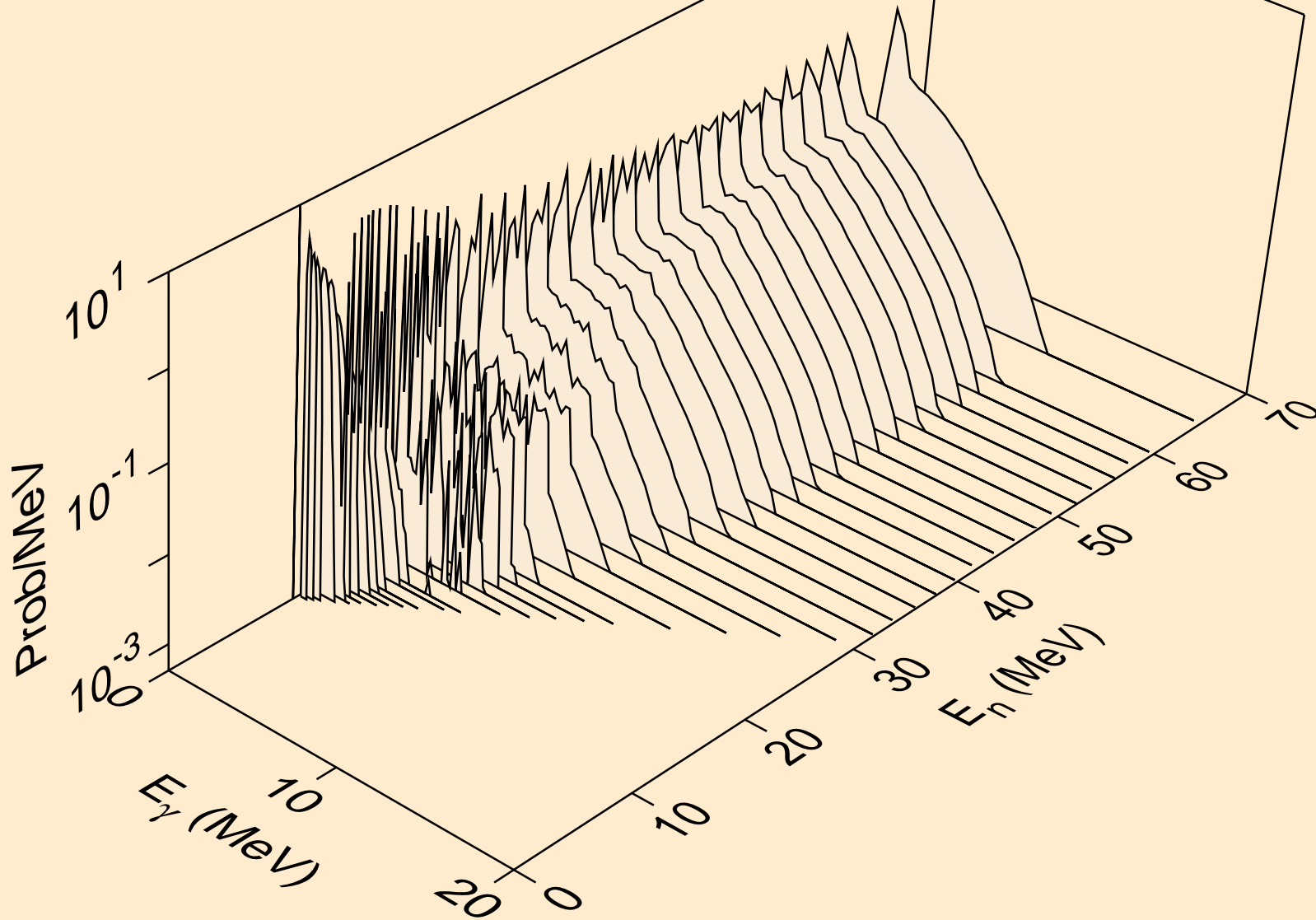

24-CR-54 FOR FENDL-3.2 FROM INDEN-1.0 BY NJOY2016.60+ OI
Photon emission for (n,2n)

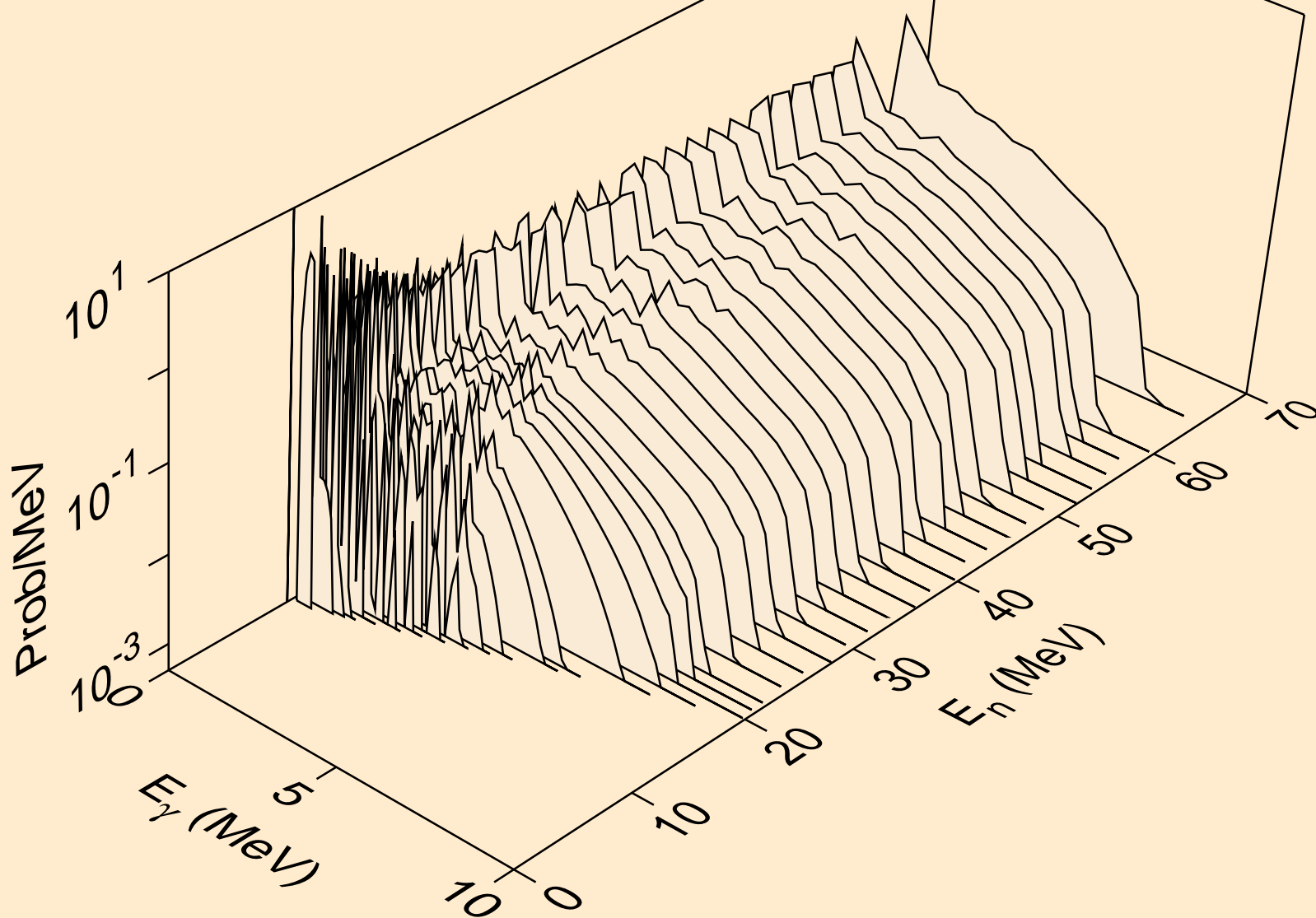

24-CR-54 FOR FENDL-3.2 FROM INDEN-1.0 BY NJOY2016.60+ OI
Photon emission for (n,n*)d

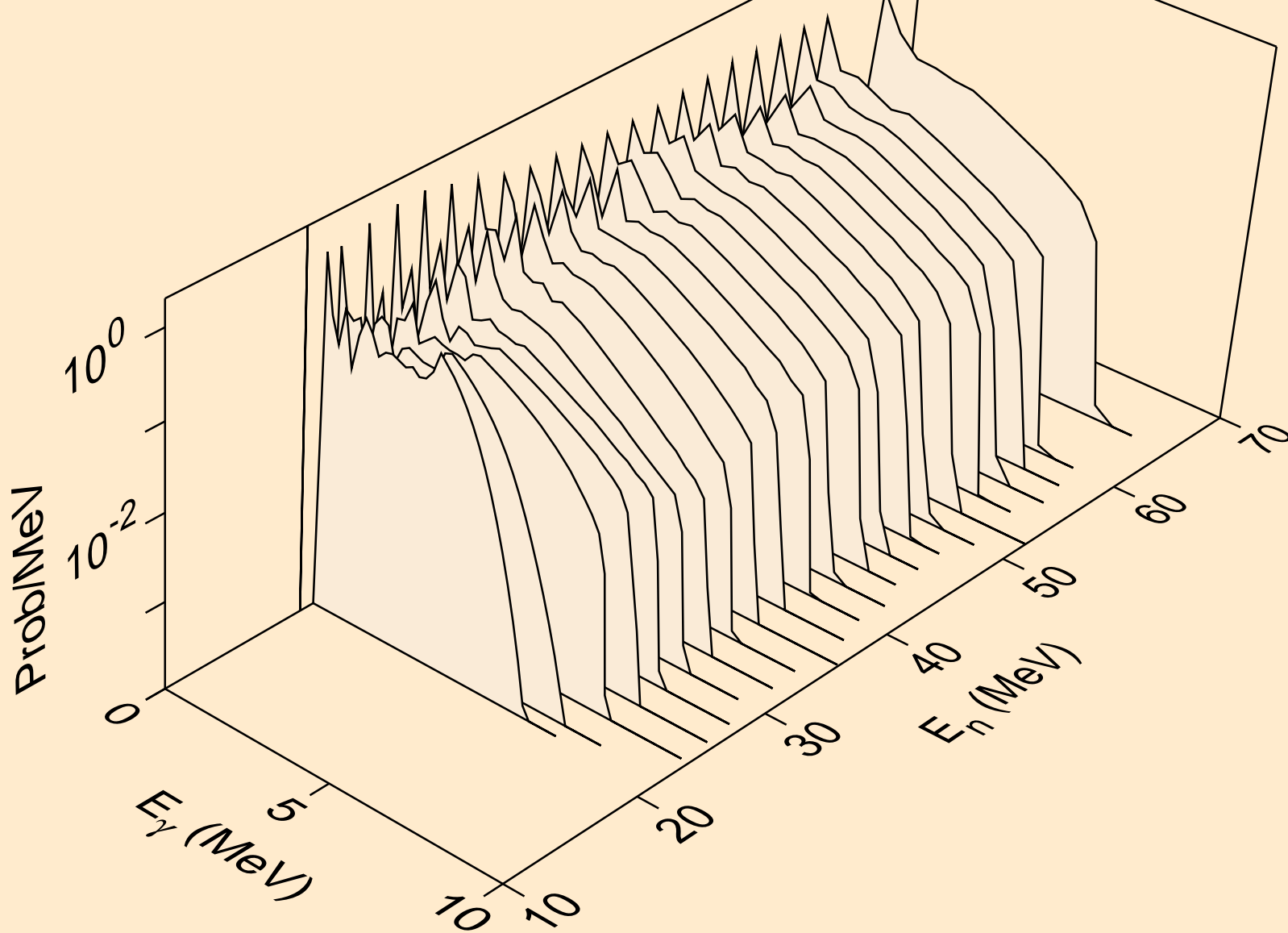

24-CR-54 FOR FENDL-3.2 FROM INDEN-1.0 BY NJOY2016.60+ OI
Photon emission for (n,n*)he3

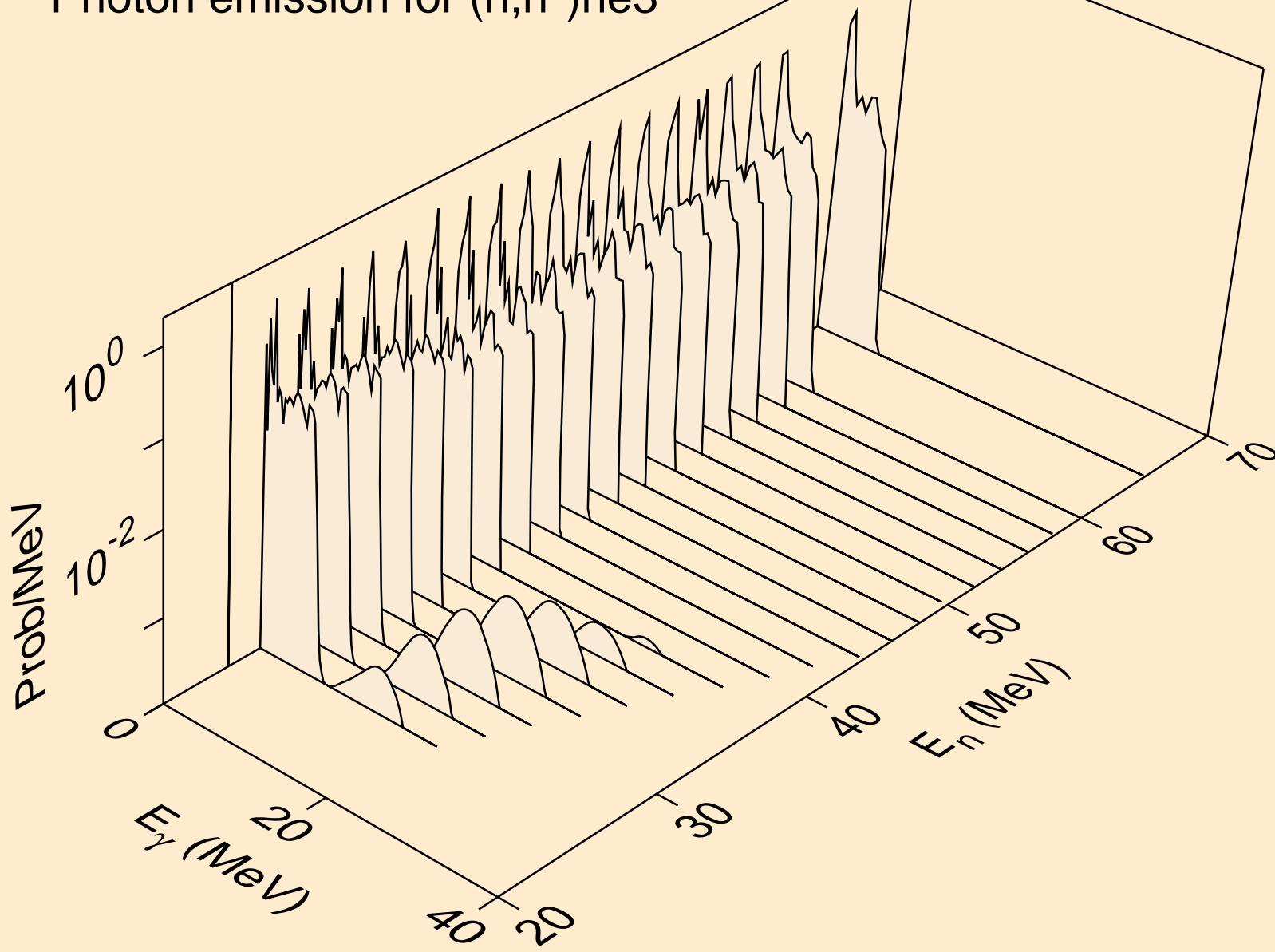

24-CR-54 FOR FENDL-3.2 FROM INDEN-1.0 BY NJOY2016.60+ OI
Photon emission for (n,2np)

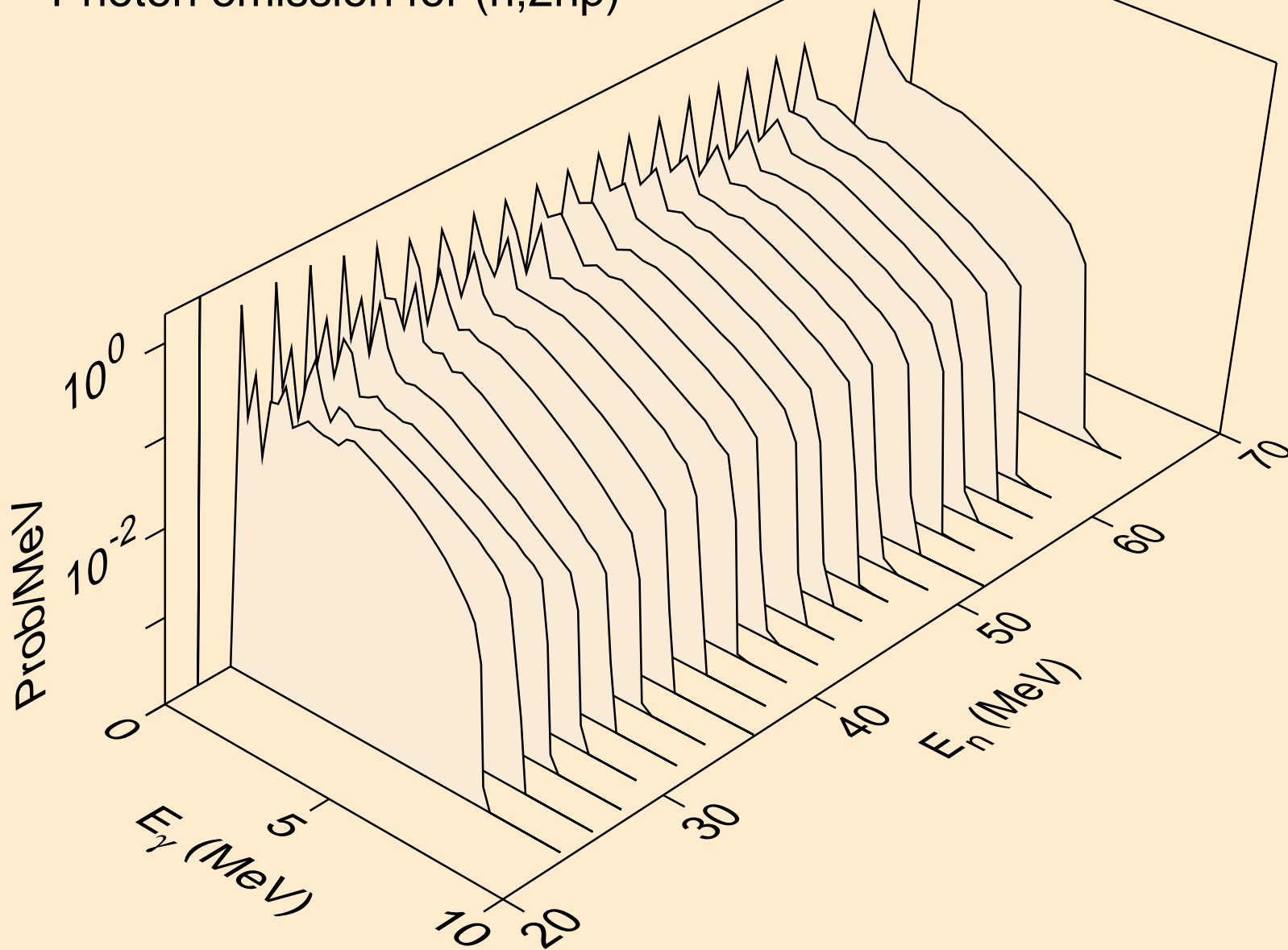

24-CR-54 FOR FENDL-3.2 FROM INDEN-1.0 BY NJOY2016.60+ OI
Photon emission for (n,2np)

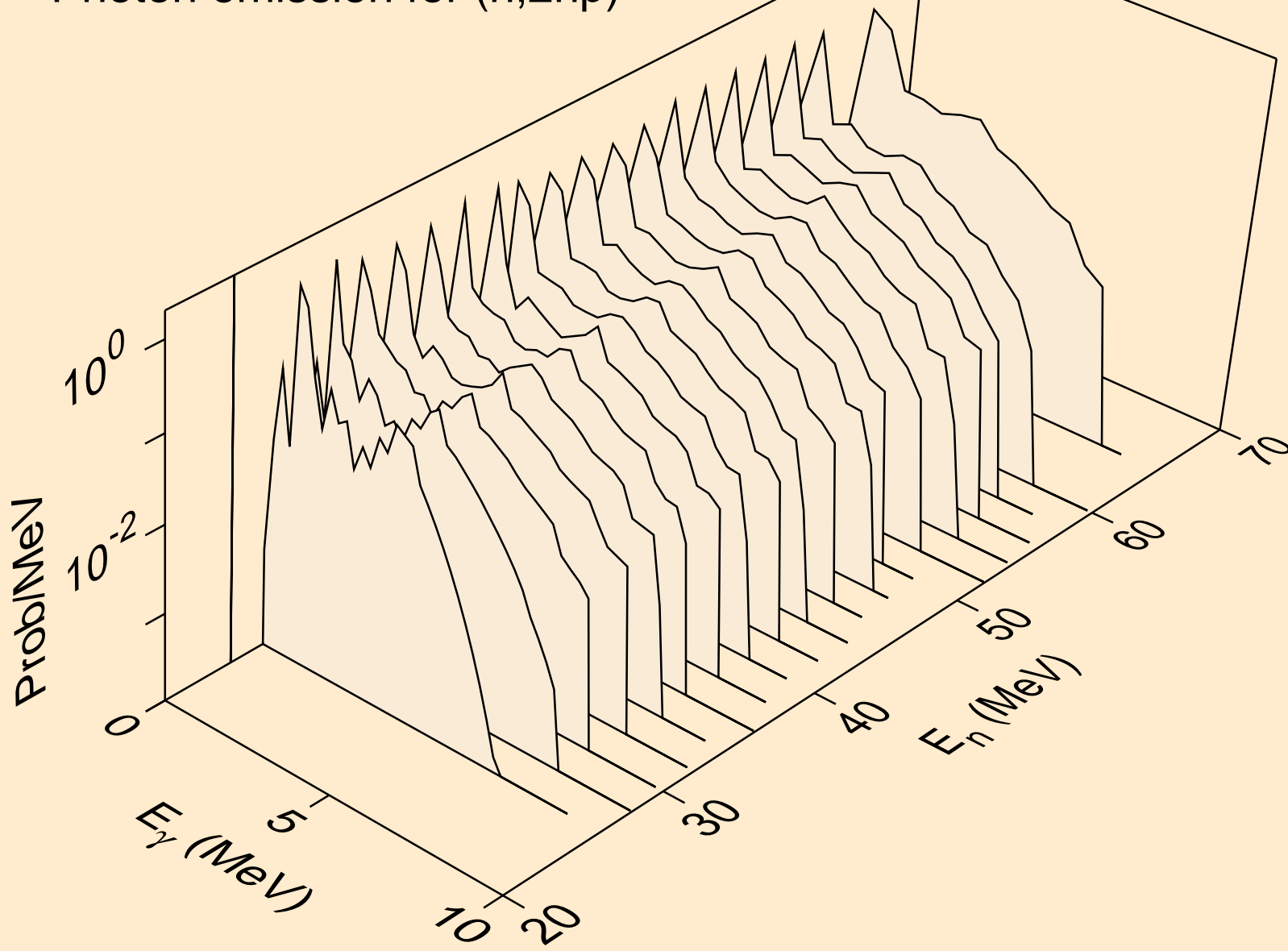

24-CR-54 FOR FENDL-3.2 FROM INDEN-1.0 BY NJOY2016.60+ OI
Photon emission for (n,n*c)

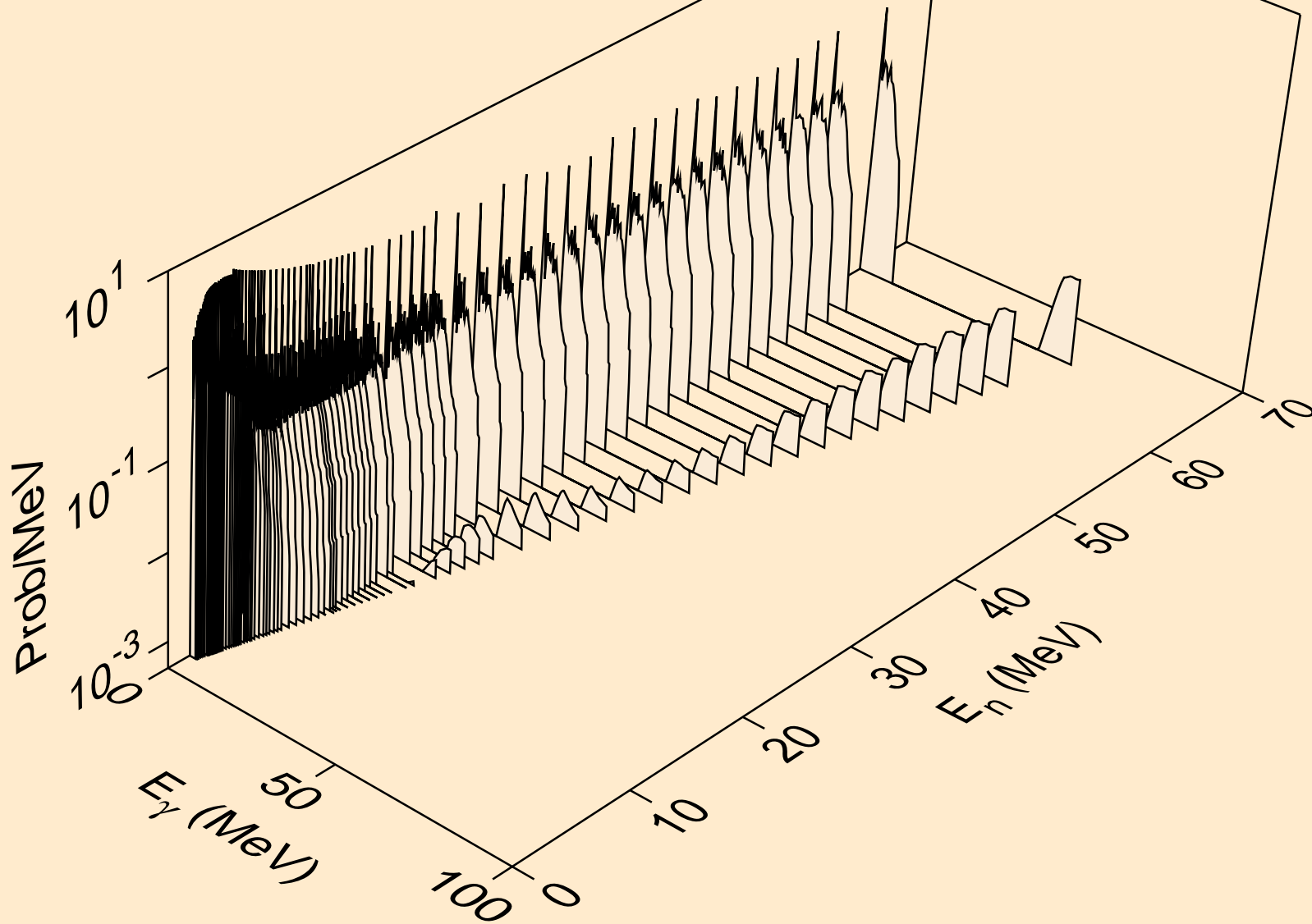

24-CR-54 FOR FENDL-3.2 FROM INDEN-1.0 BY NJOY2016.60+ OI
Photon emission for (n,gma)

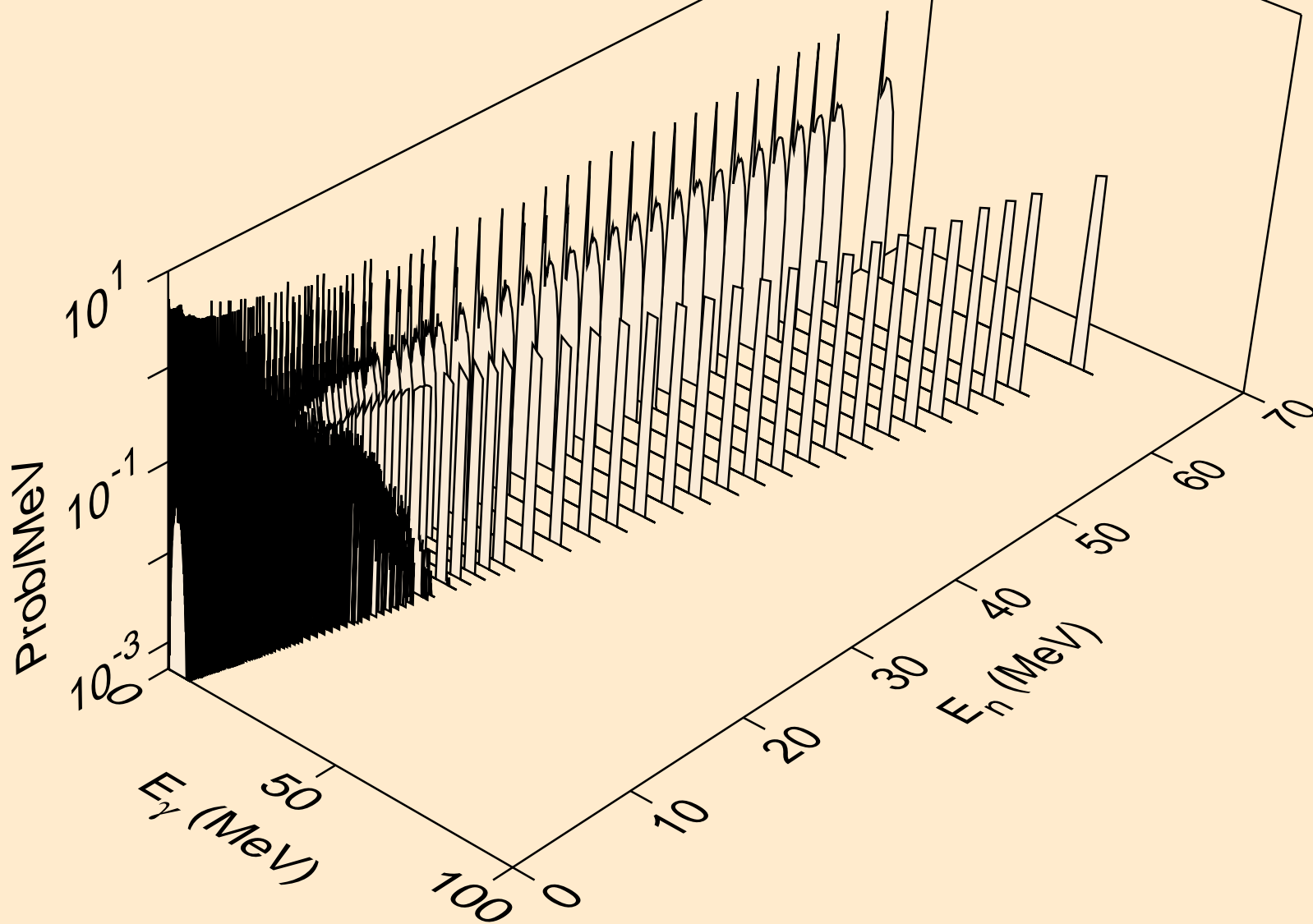

24-CR-54 FOR FENDL-3.2 FROM INDEN-1.0 BY NJOY2016.60+ OI
Photon emission for (n,d)

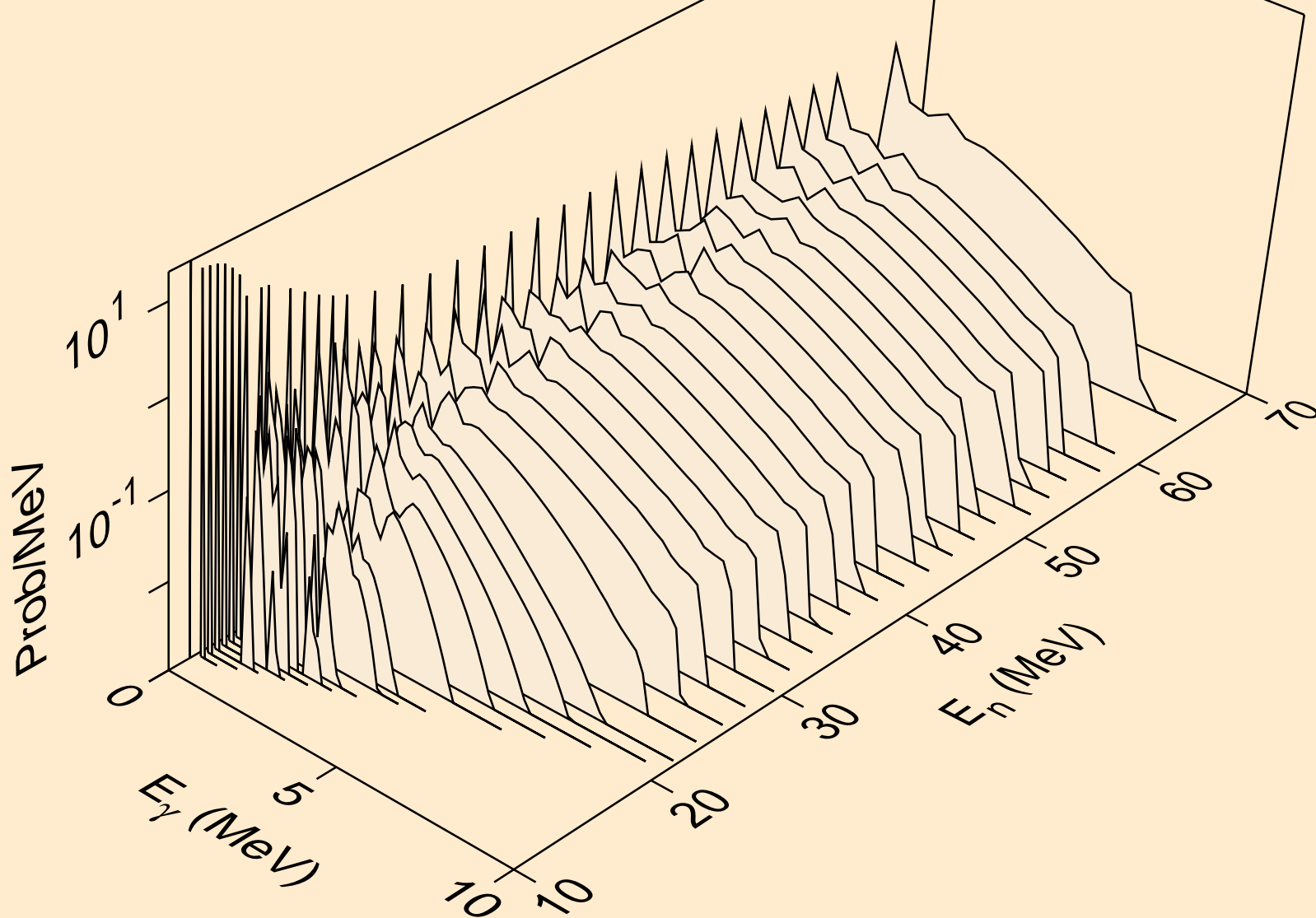

24-CR-54 FOR FENDL-3.2 FROM INDEN-1.0 BY NJOY2016.60+ OI
Photon emission for (n,t)

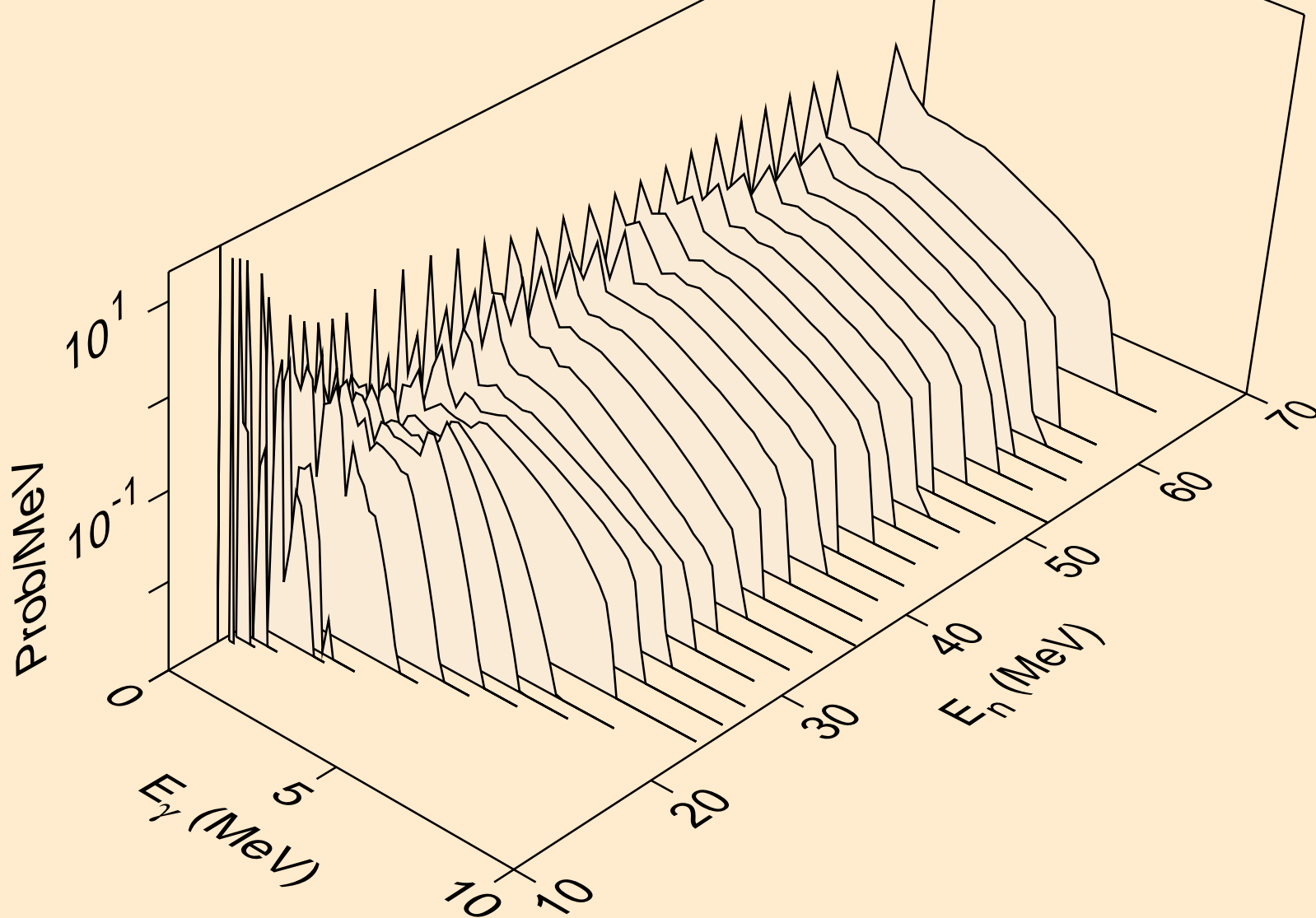

24-CR-54 FOR FENDL-3.2 FROM INDEN-1.0 BY NJOY2016.60+ OI
Photon emission for (n,he3)

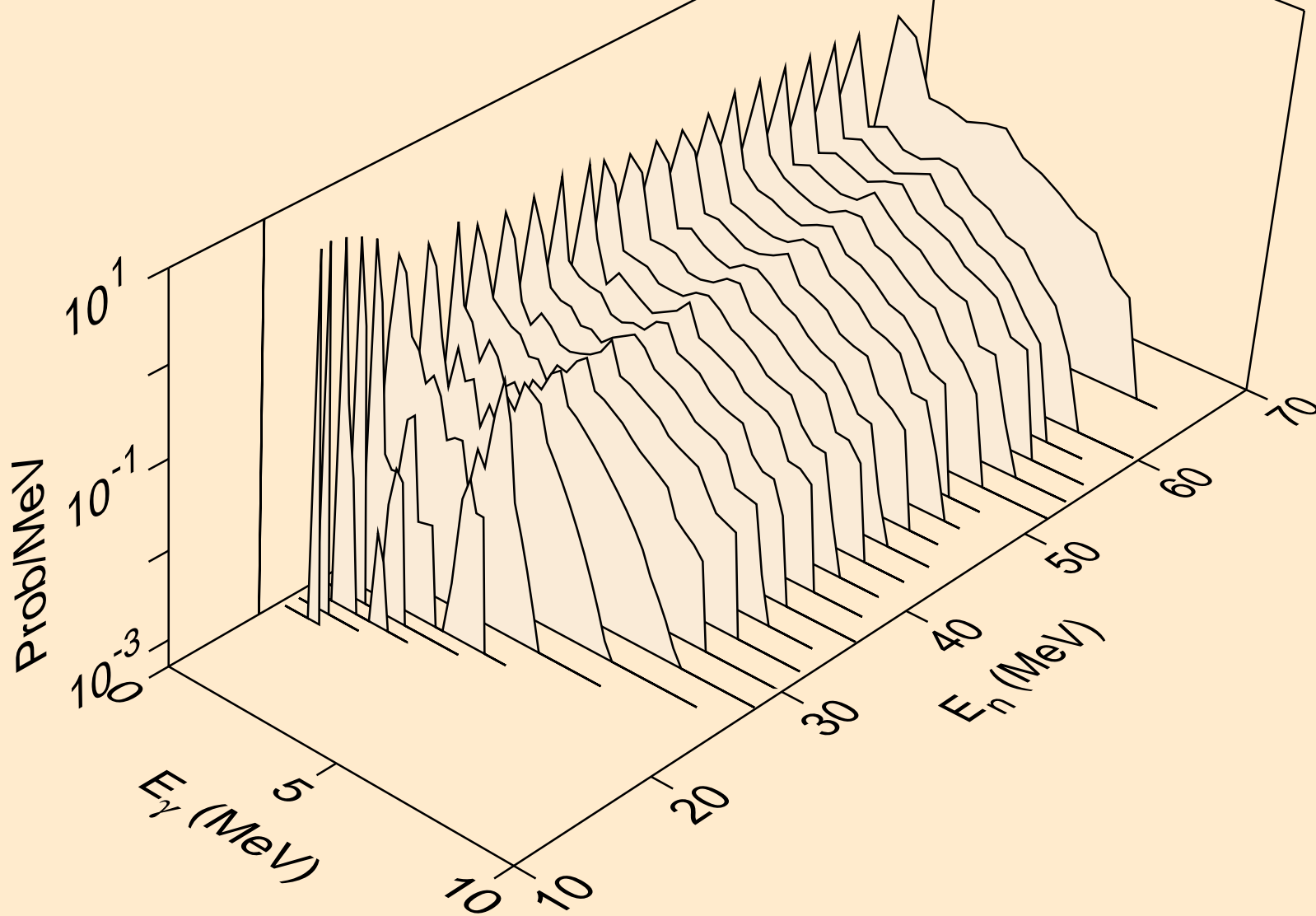

24-CR-54 FOR FENDL-3.2 FROM INDEN-1.0 BY NJOY2016.60+ OI
Photon emission for (n,2p)

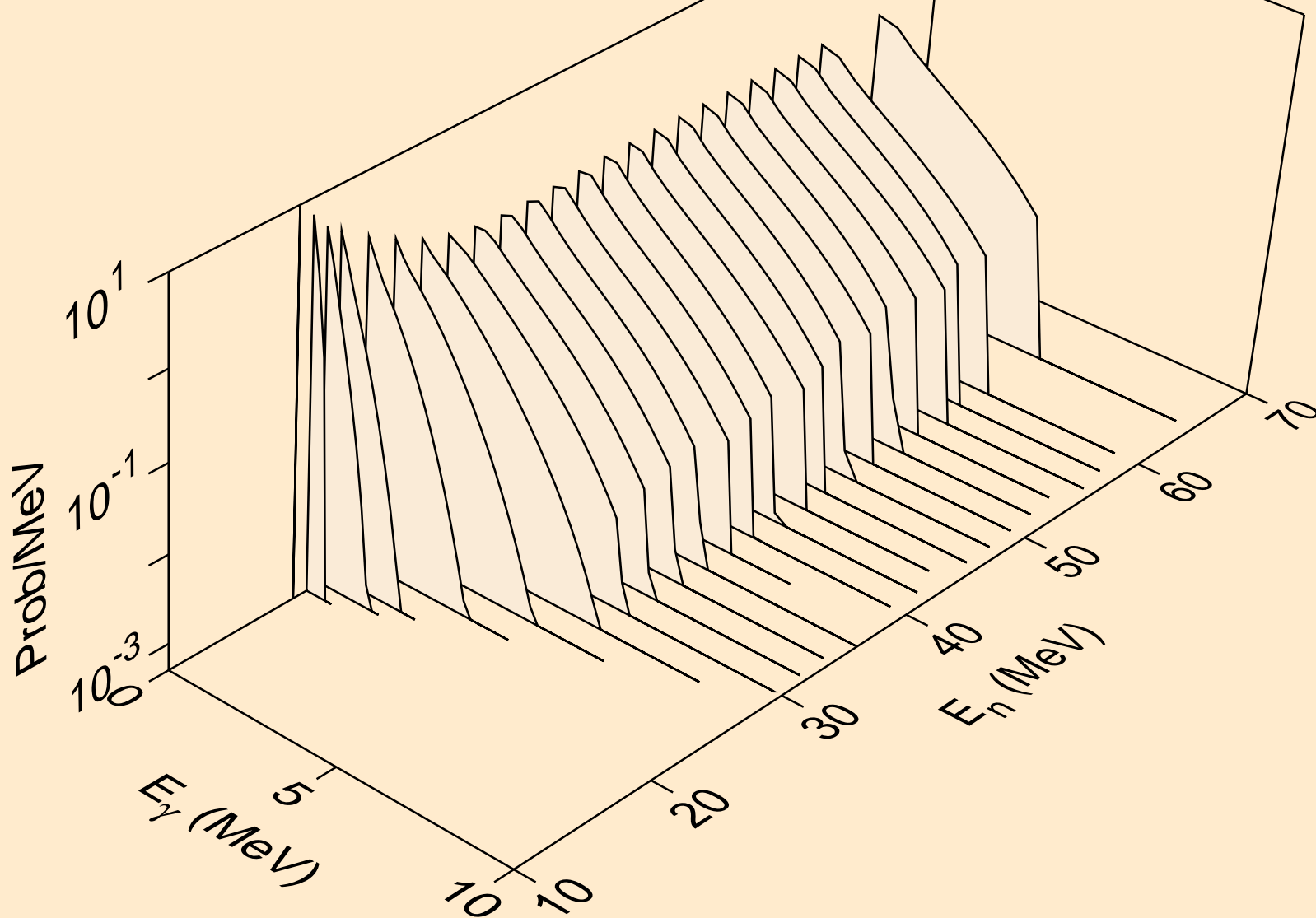

24-CR-54 FOR FENDL-3.2 FROM INDEN-1.0 BY NJOY2016.60+ OI
Photon emission for (n,pd)

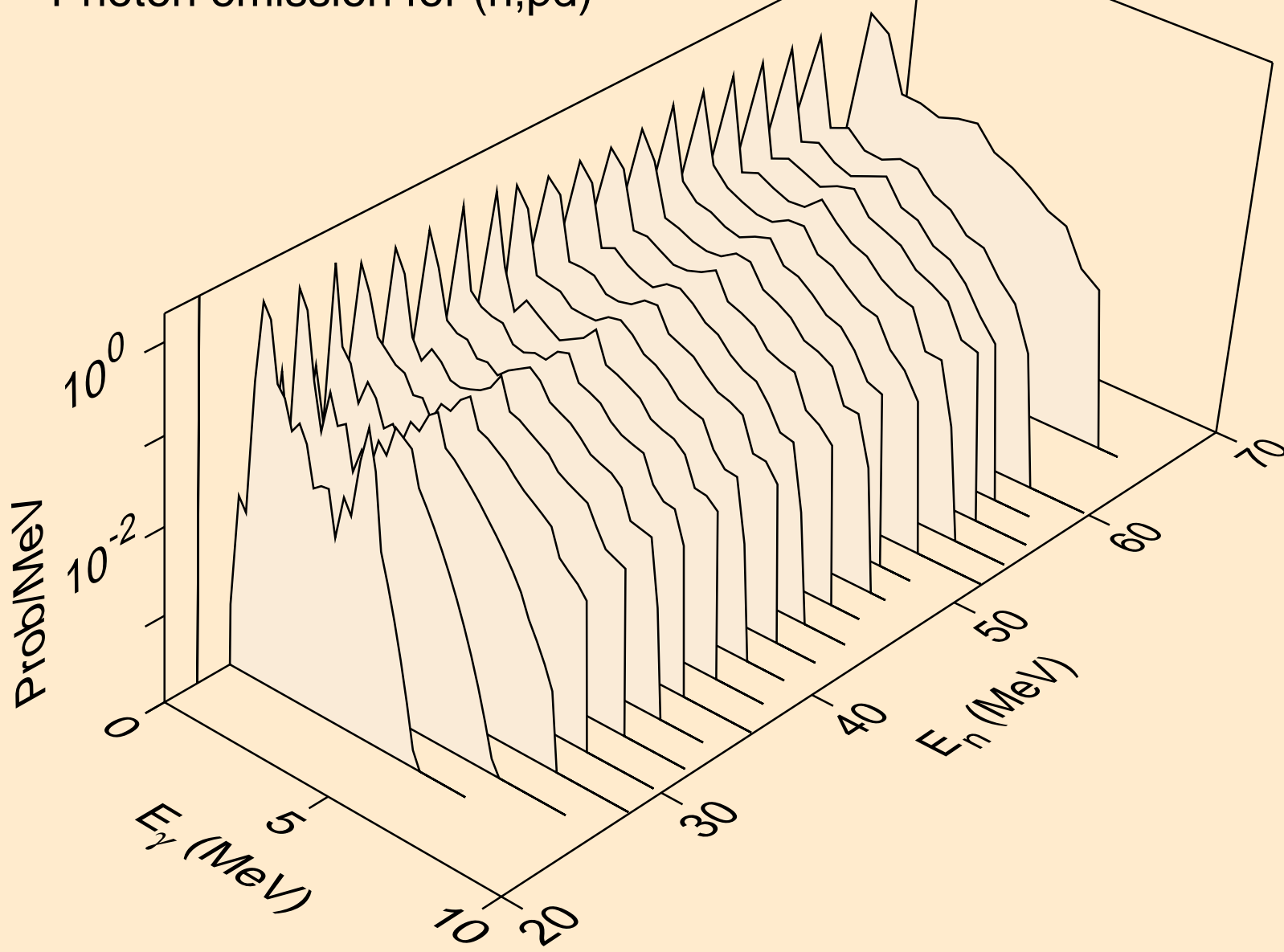

24-CR-54 FOR FENDL-3.2 FROM INDEN-1.0 BY NJOY2016.60+ OI
Photon emission for (n,pt)

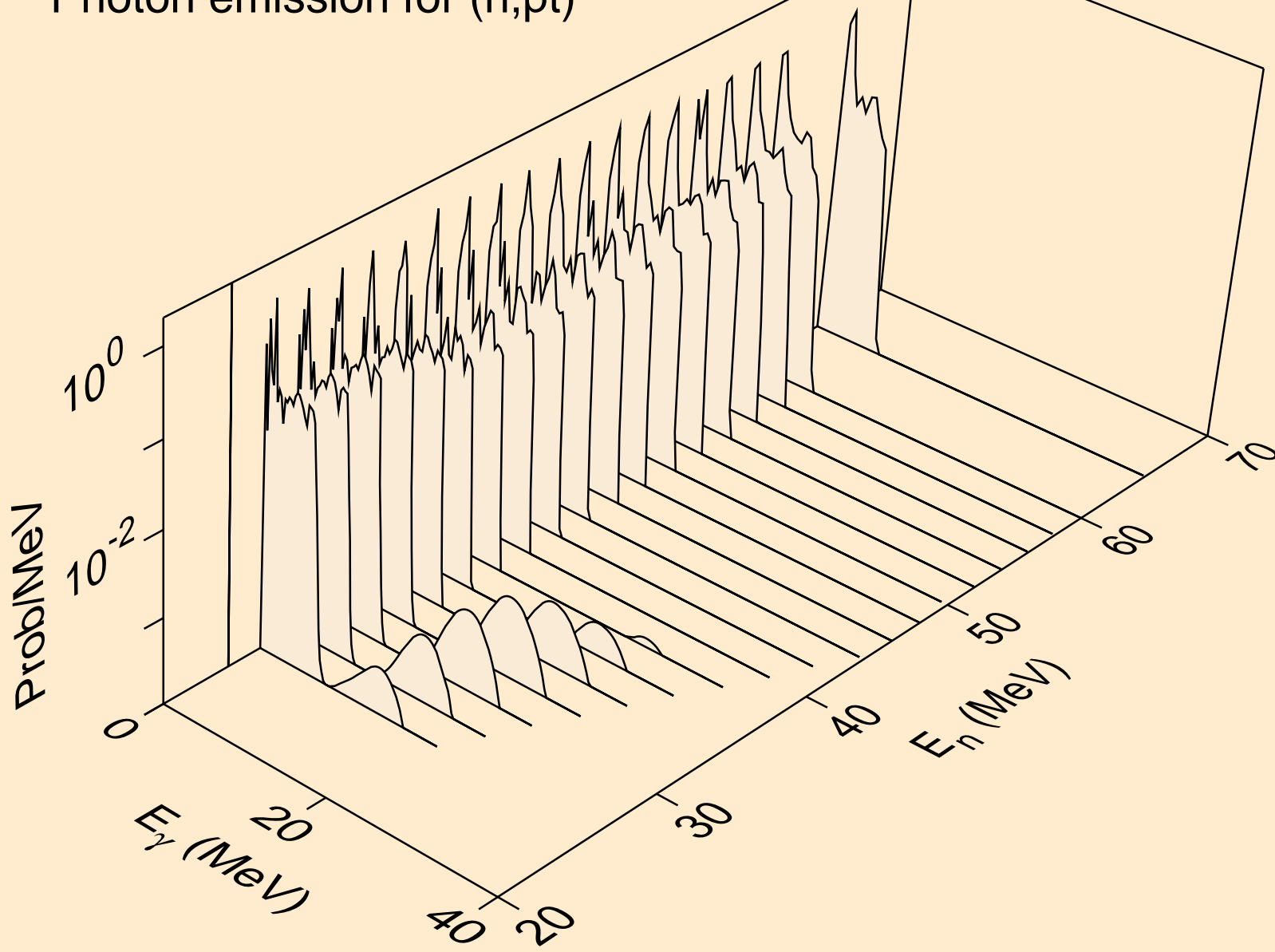

24-CR-54 FOR FENDL-3.2 FROM INDEN-1.0 BY NJOY2016.60+ OI
Photon emission for (n,p*c)

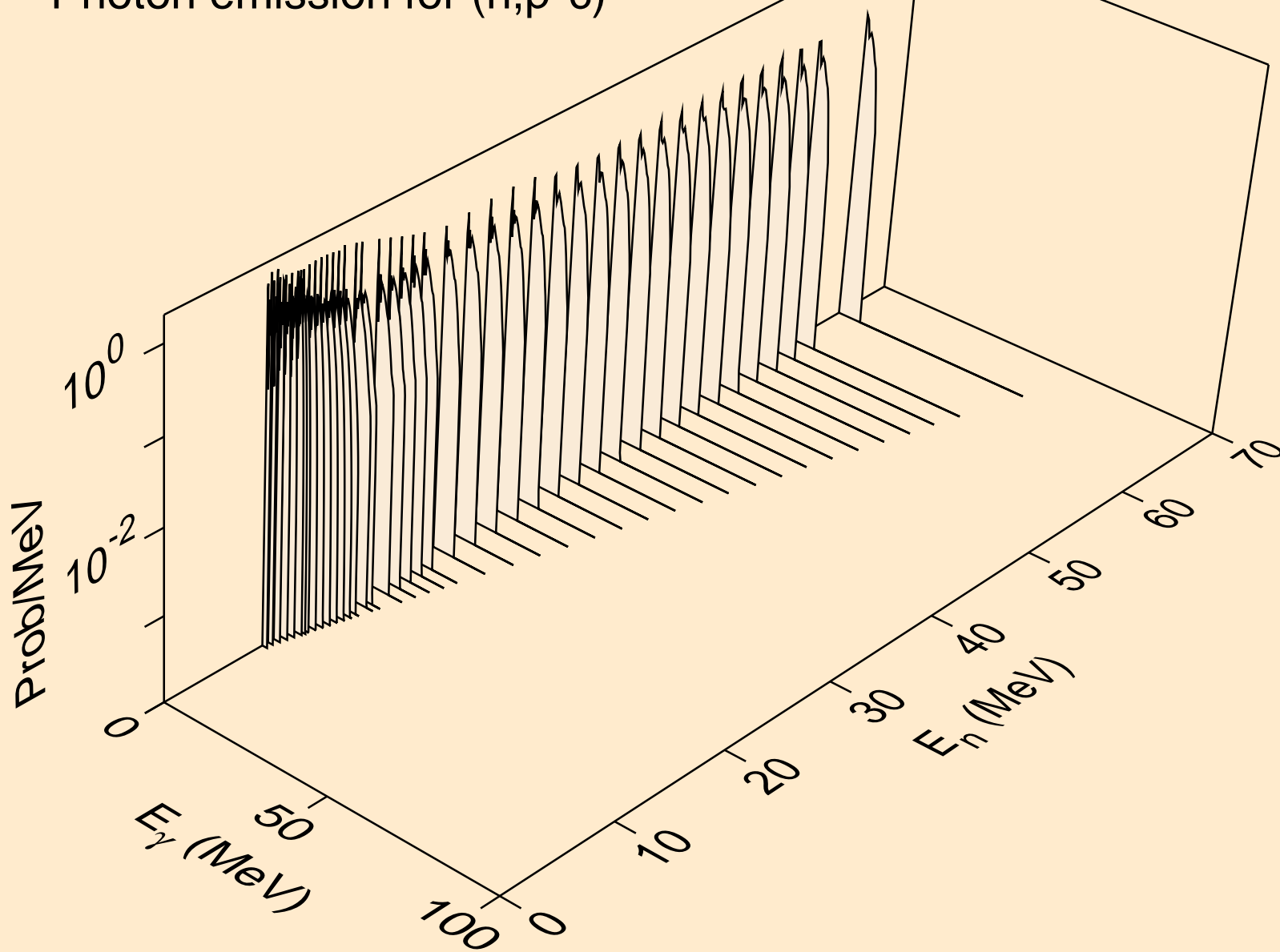

24-CR-54 FOR FENDL-3.2 FROM INDEN-1.0 BY NJOY2016.60+ OI
Photon emission for (n,a*c)

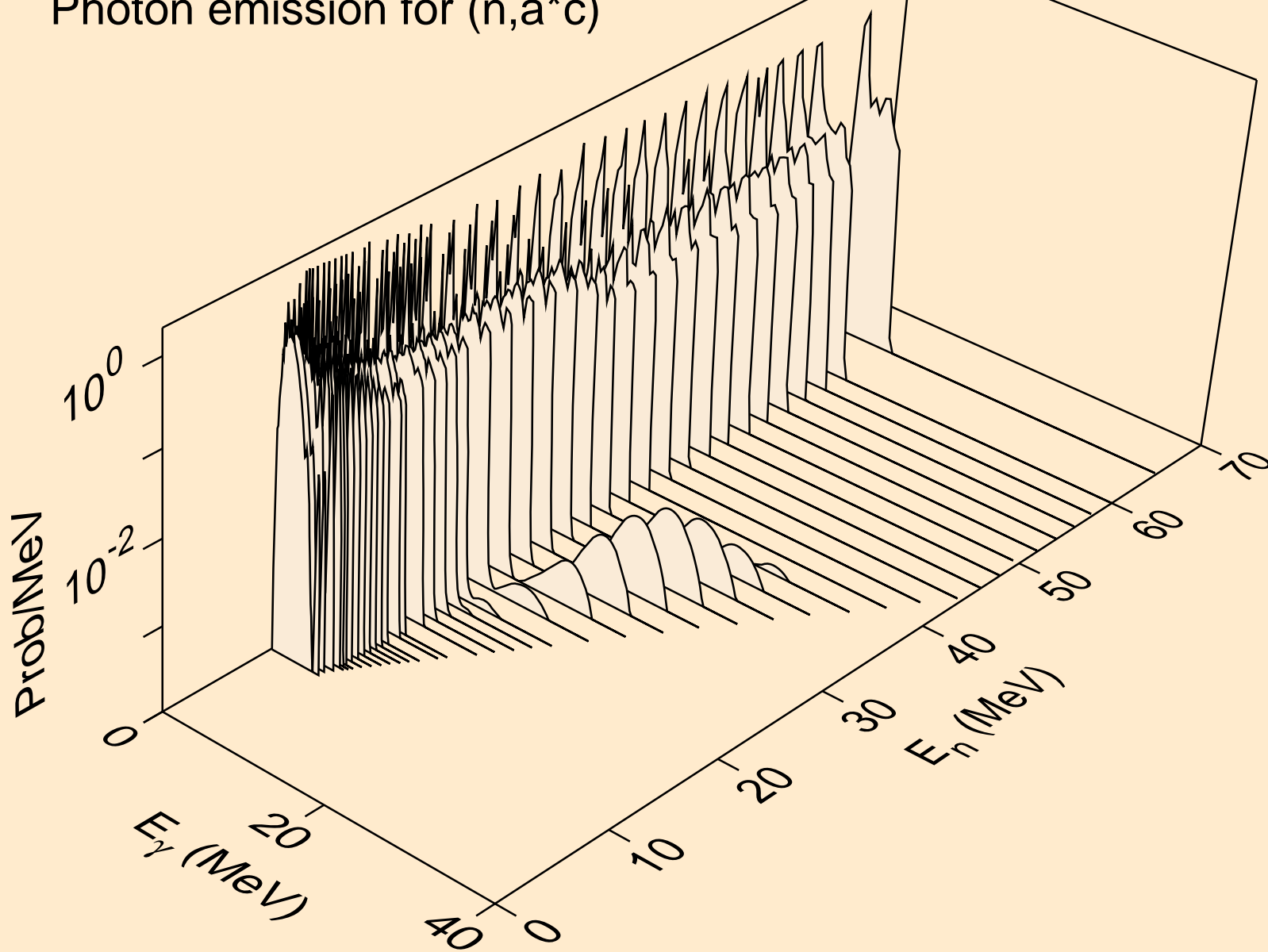

24-CR-54 FOR FENDL-3.2 FROM INDEN-1.0 BY NJOY2016.60+ OI
thermal capture photon spectrum

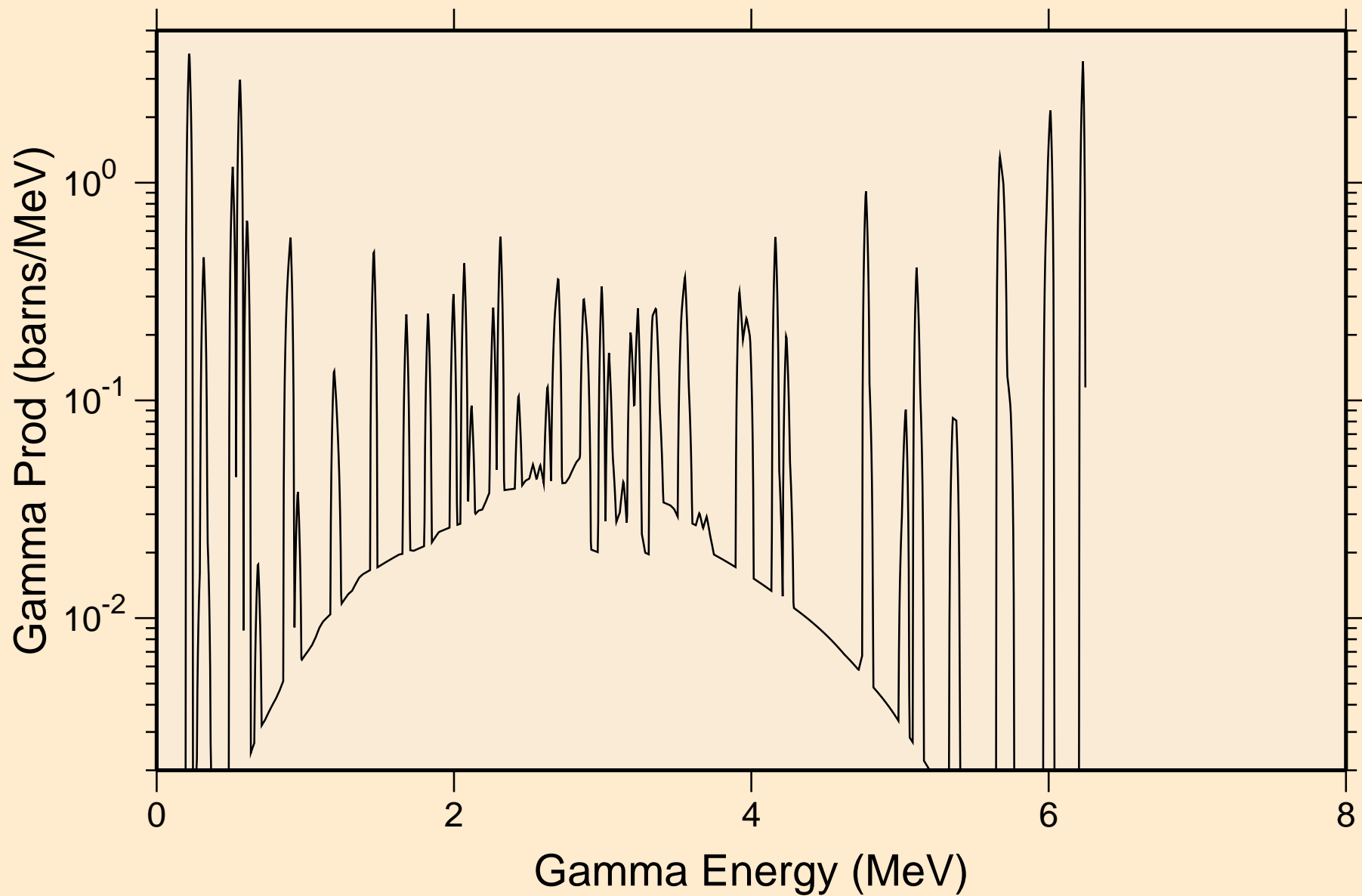

24-CR-54 FOR FENDL-3.2 FROM INDEN-1.0 BY NJOY2016.60+ OI
14 MeV photon spectrum

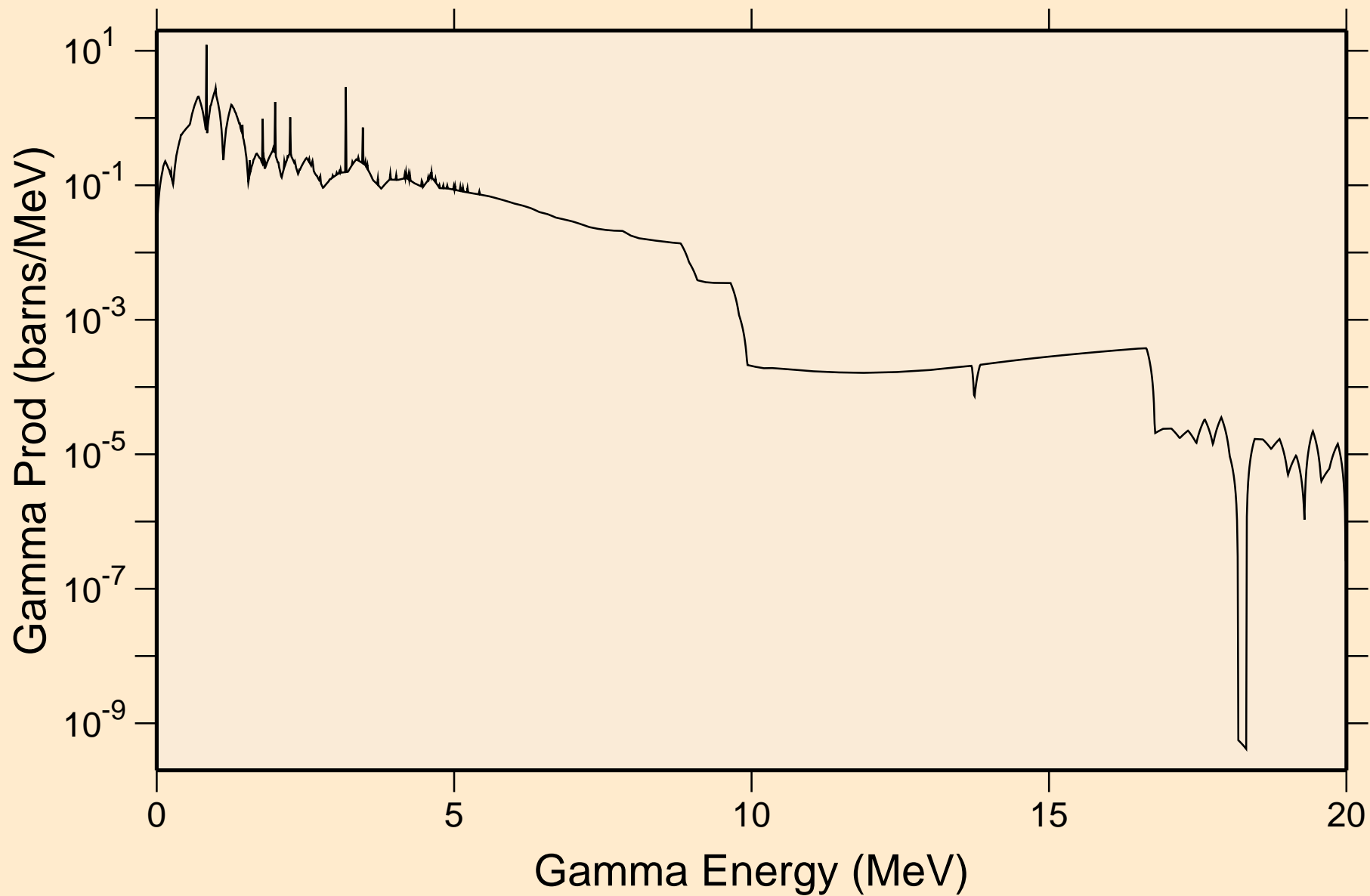

24-CR-54 FOR FENDL-3.2 FROM INDEN-1.0 BY NJOY2016.60+ OI

Particle heating contributions

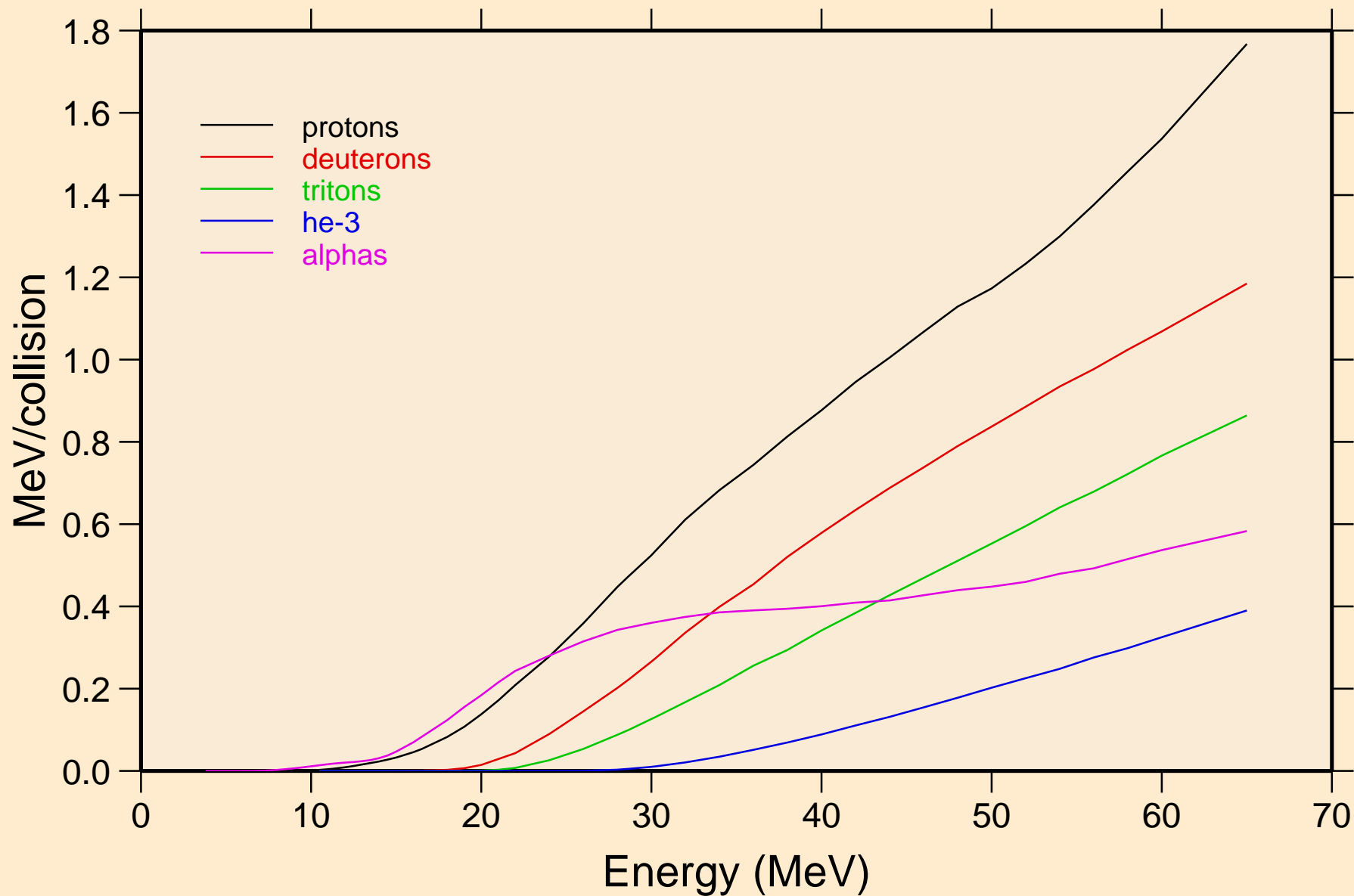

24-CR-54 FOR FENDL-3.2 FROM INDEN-1.0 BY NJOY2016.60+ OI Recoil Heating

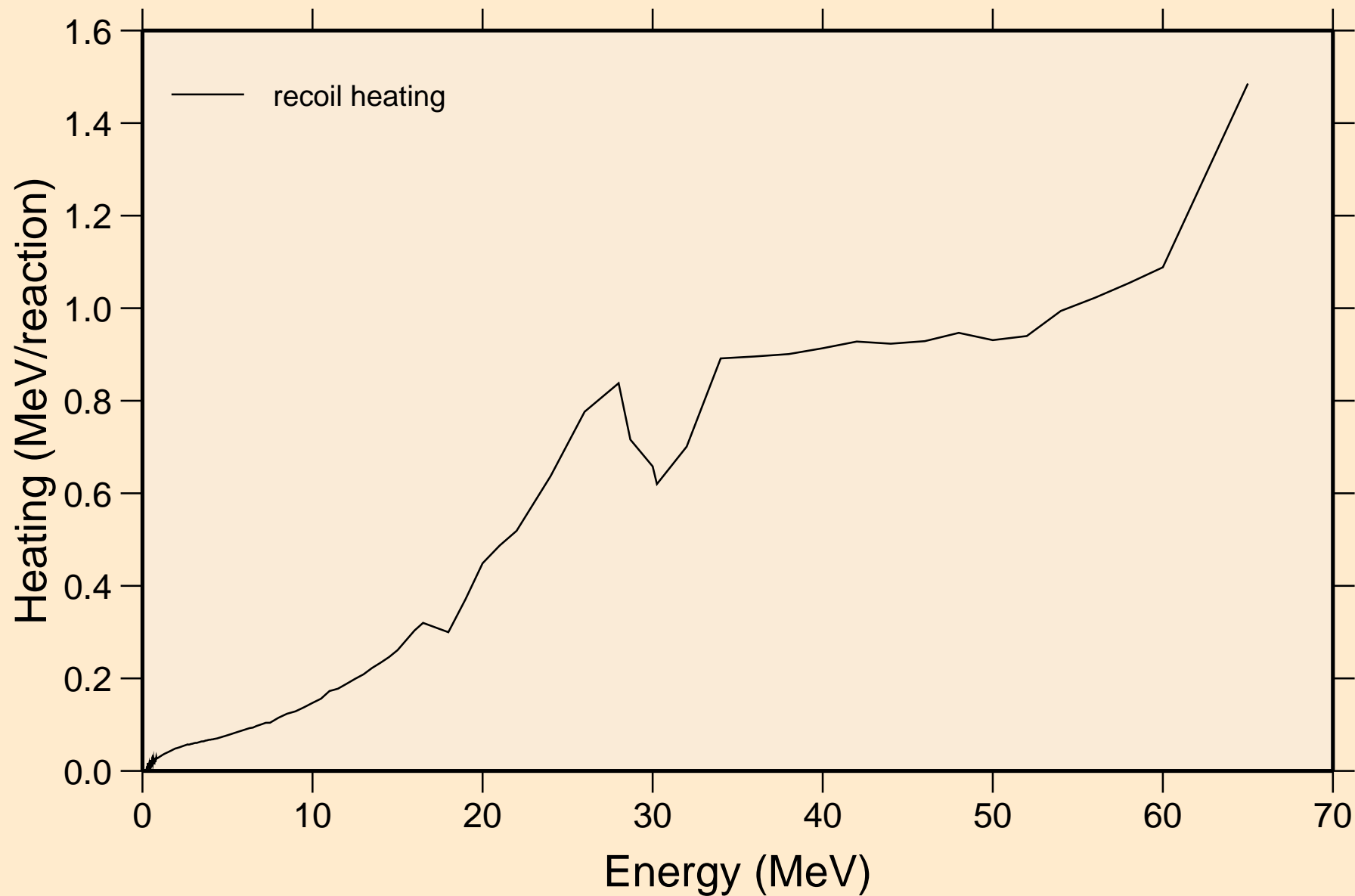

24-CR-54 FOR FENDL-3.2 FROM INDEN-1.0 BY NJOY2016.60+ OI
Particle production cross sections

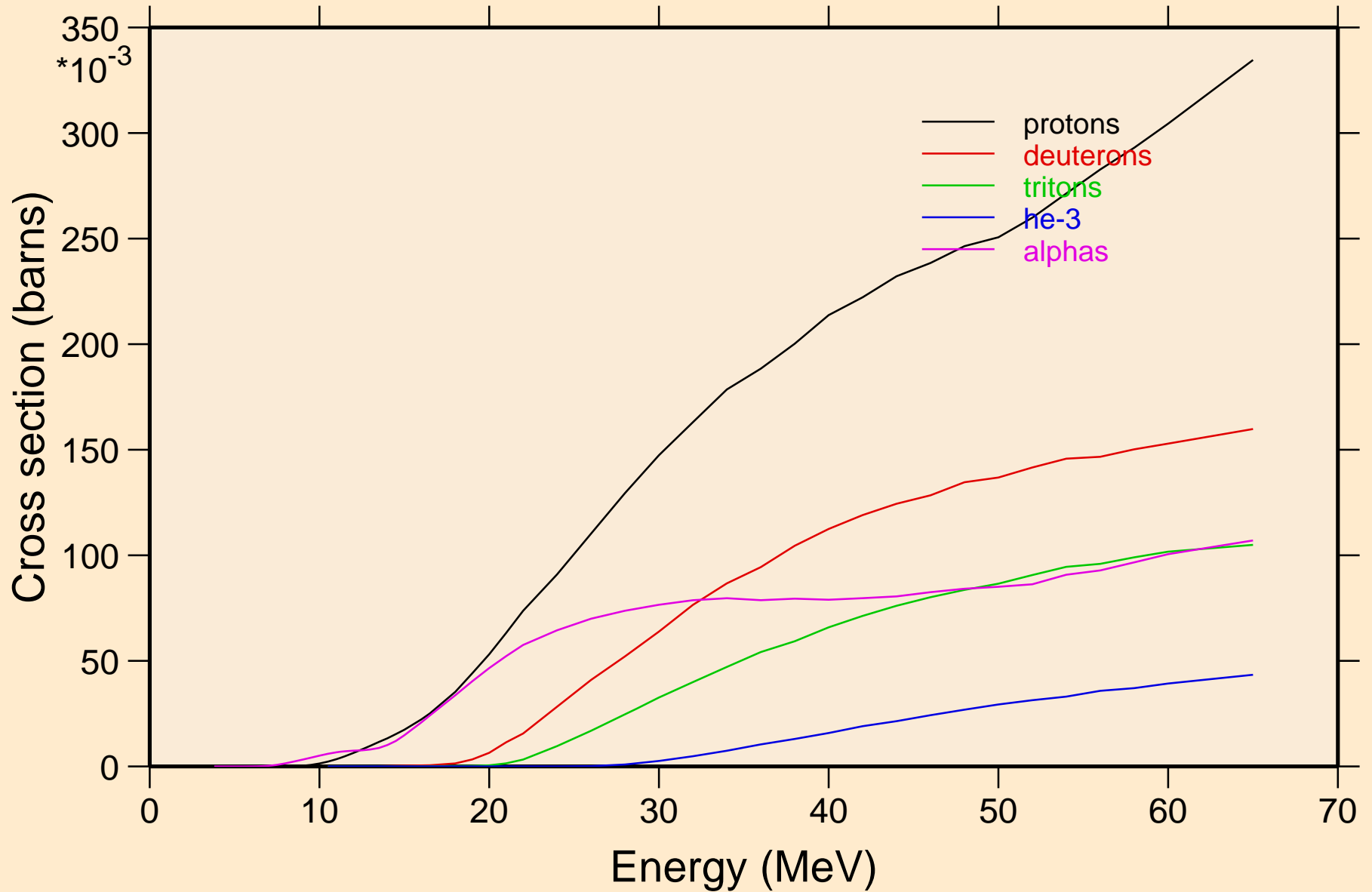

24-CR-54 FOR FENDL-3.2 FROM INDEN-1.0 BY NJOY2016.60+ OI
protons from (n,x)

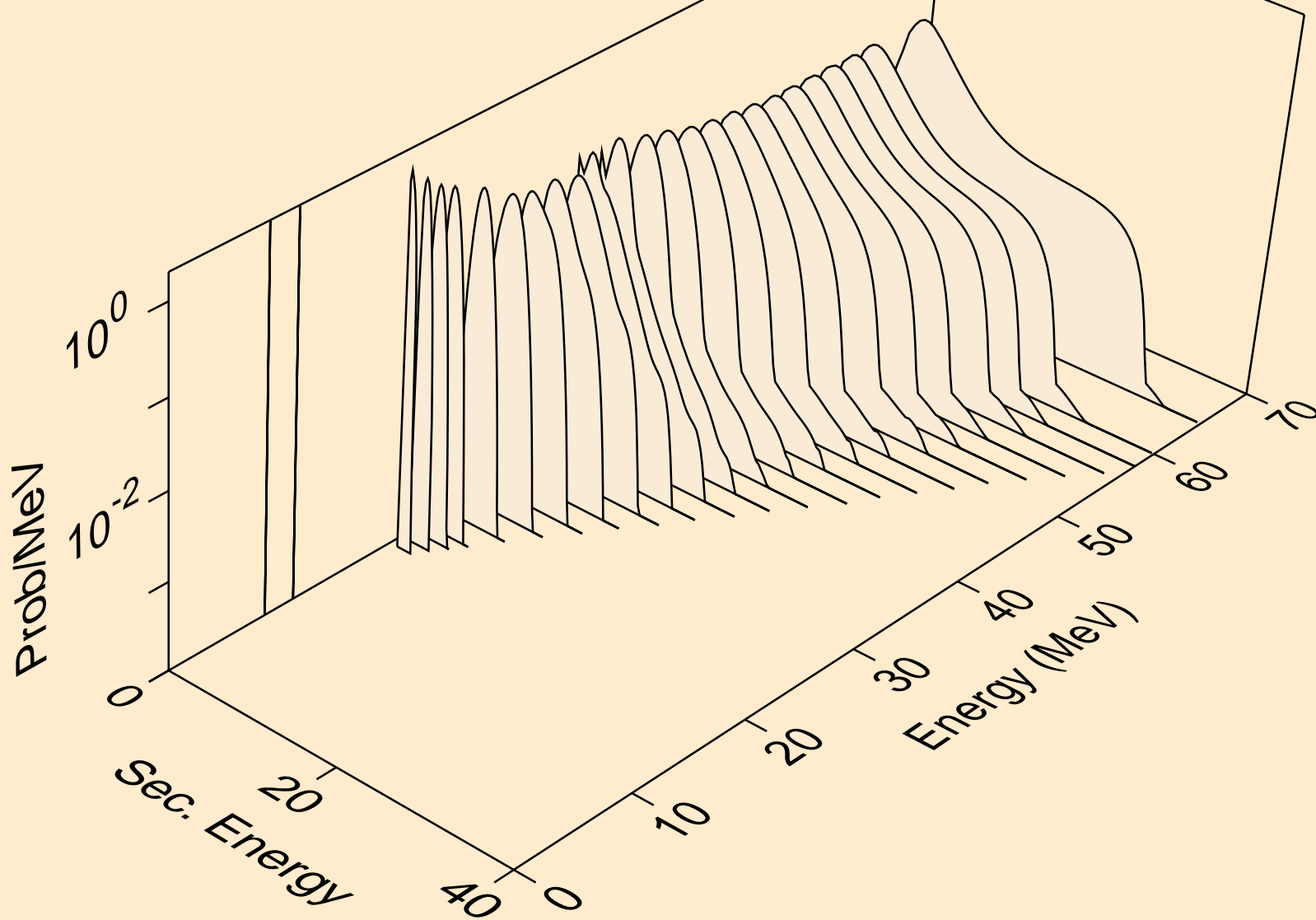

24-CR-54 FOR FENDL-3.2 FROM INDEN-1.0 BY NJOY2016.60+ OI
protons from (n,n*)p

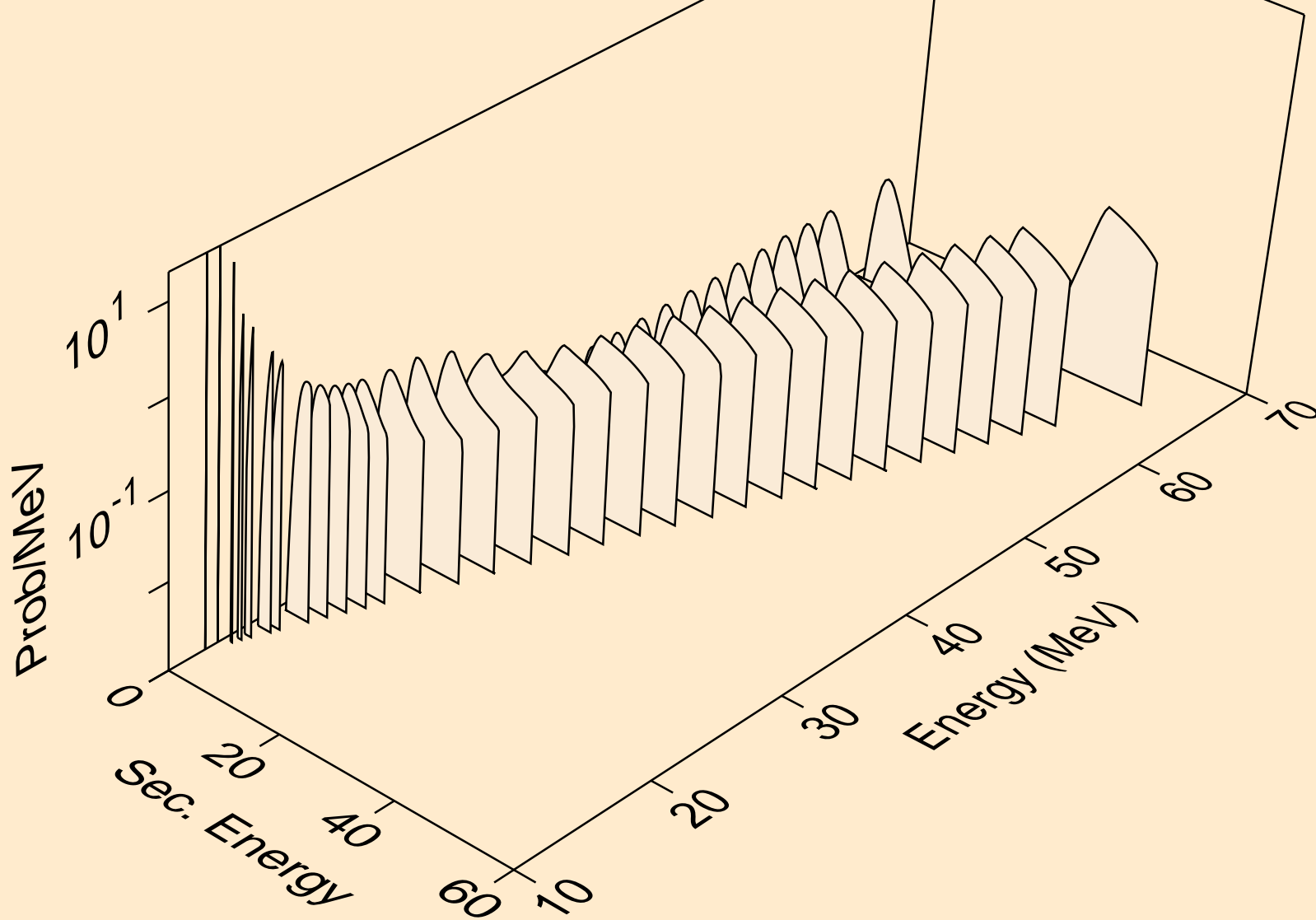

24-CR-54 FOR FENDL-3.2 FROM INDEN-1.0 BY NJOY2016.60+ OI
protons from (n,2np)

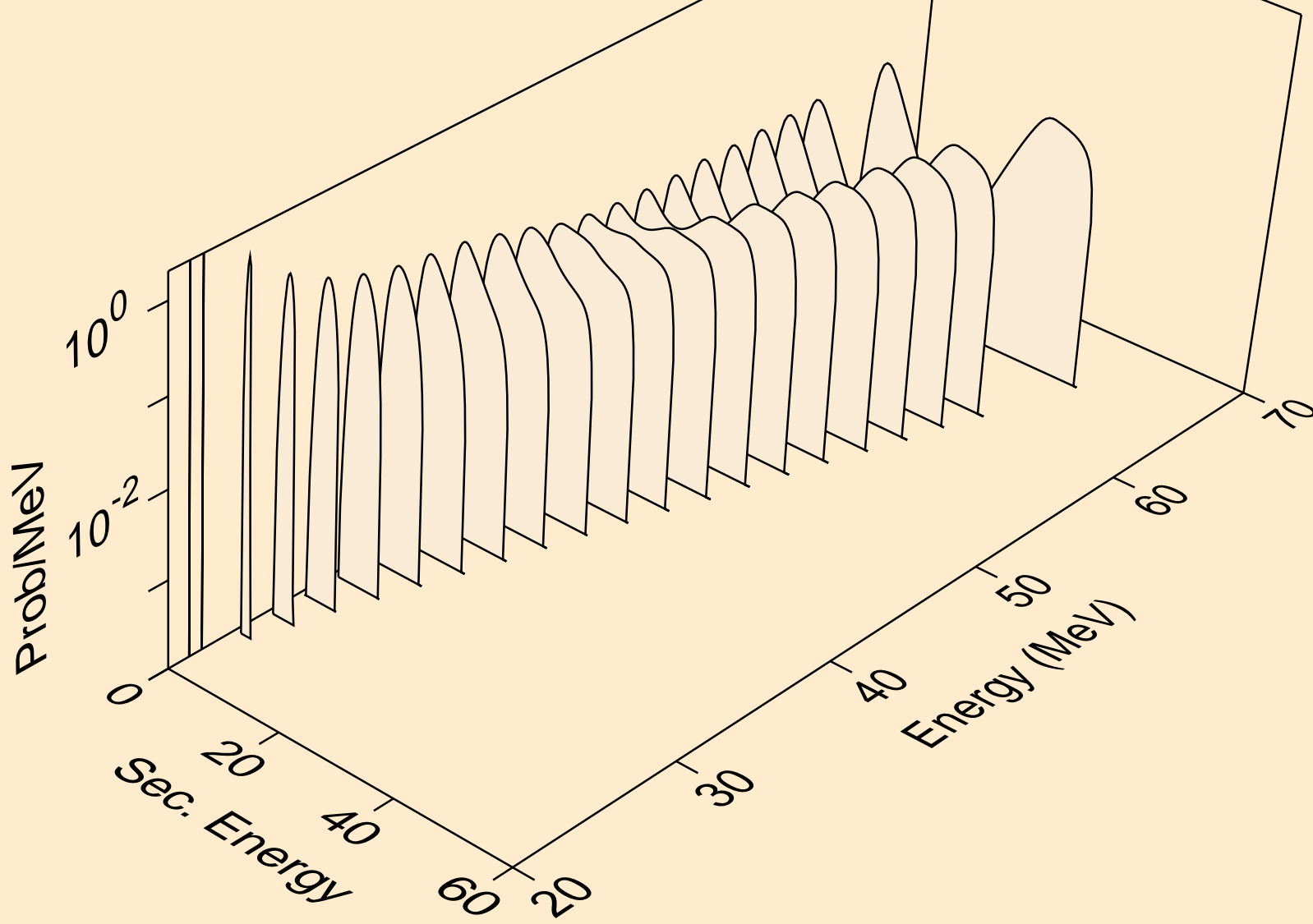

24-CR-54 FOR FENDL-3.2 FROM INDEN-1.0 BY NJOY2016.60+ OI
protons from (n,2np)

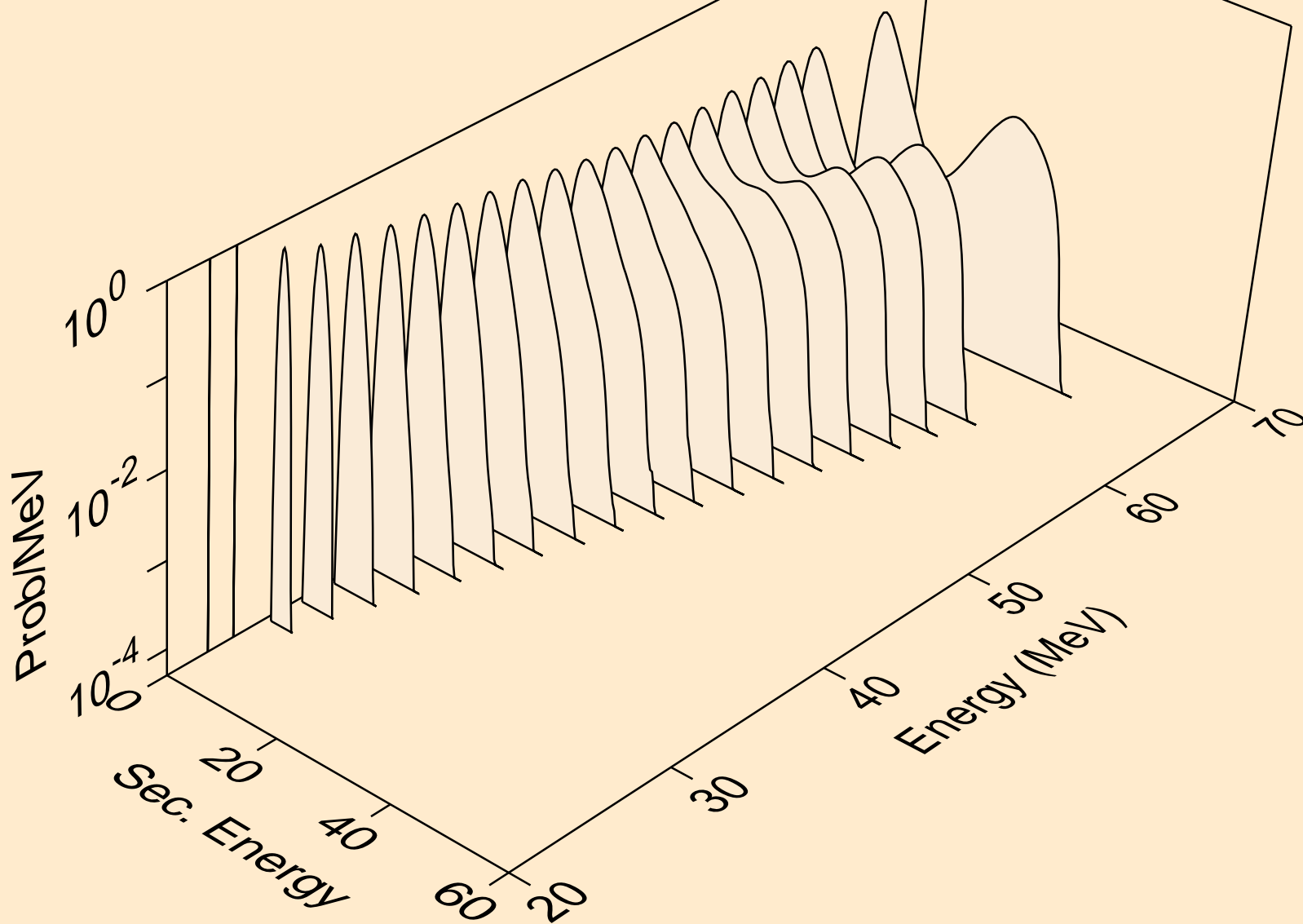

24-CR-54 FOR FENDL-3.2 FROM INDEN-1.0 BY NJOY2016.60+ OI
protons from (n,2p)

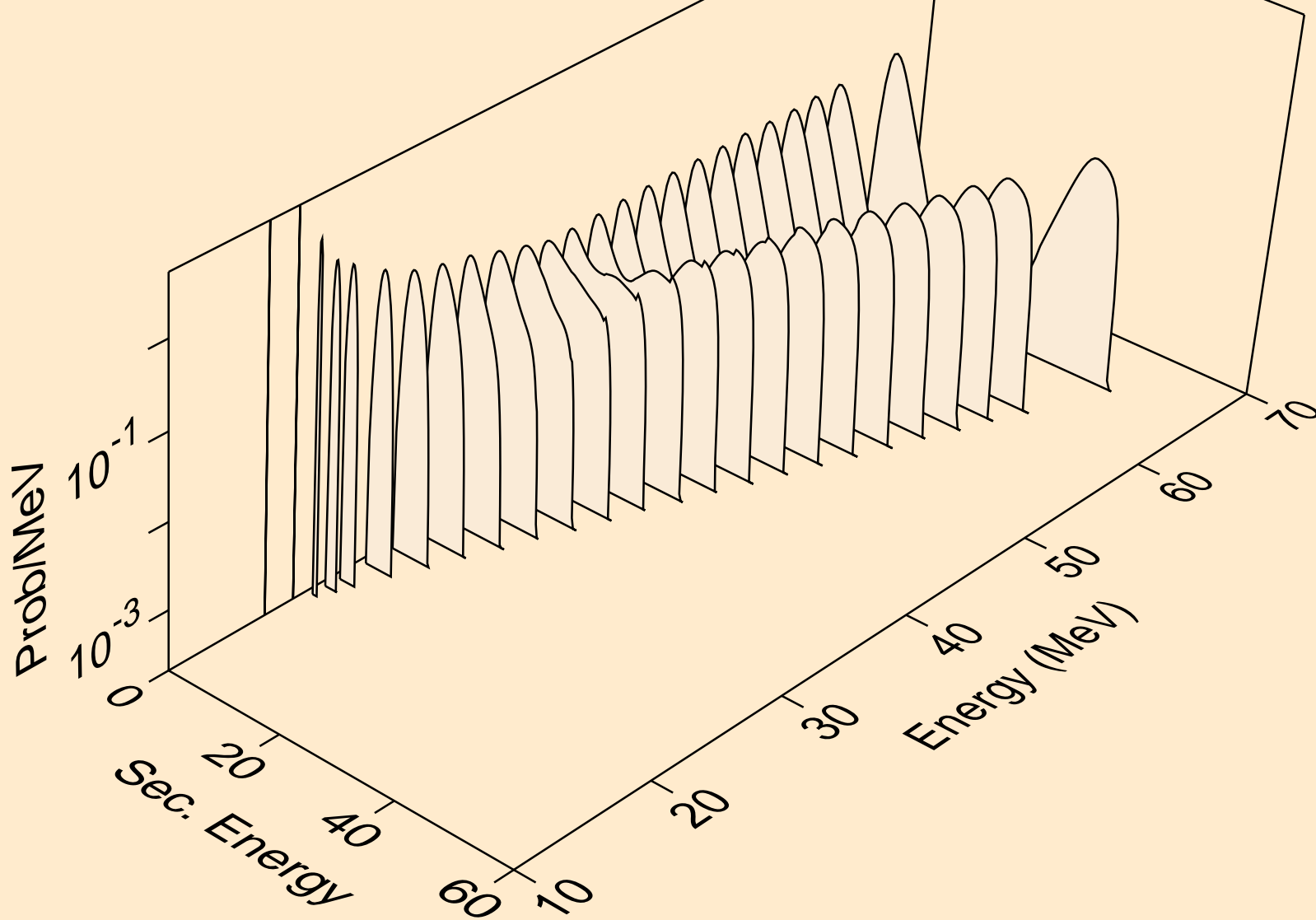

24-CR-54 FOR FENDL-3.2 FROM INDEN-1.0 BY NJOY2016.60+ OI
protons from (n,pd)

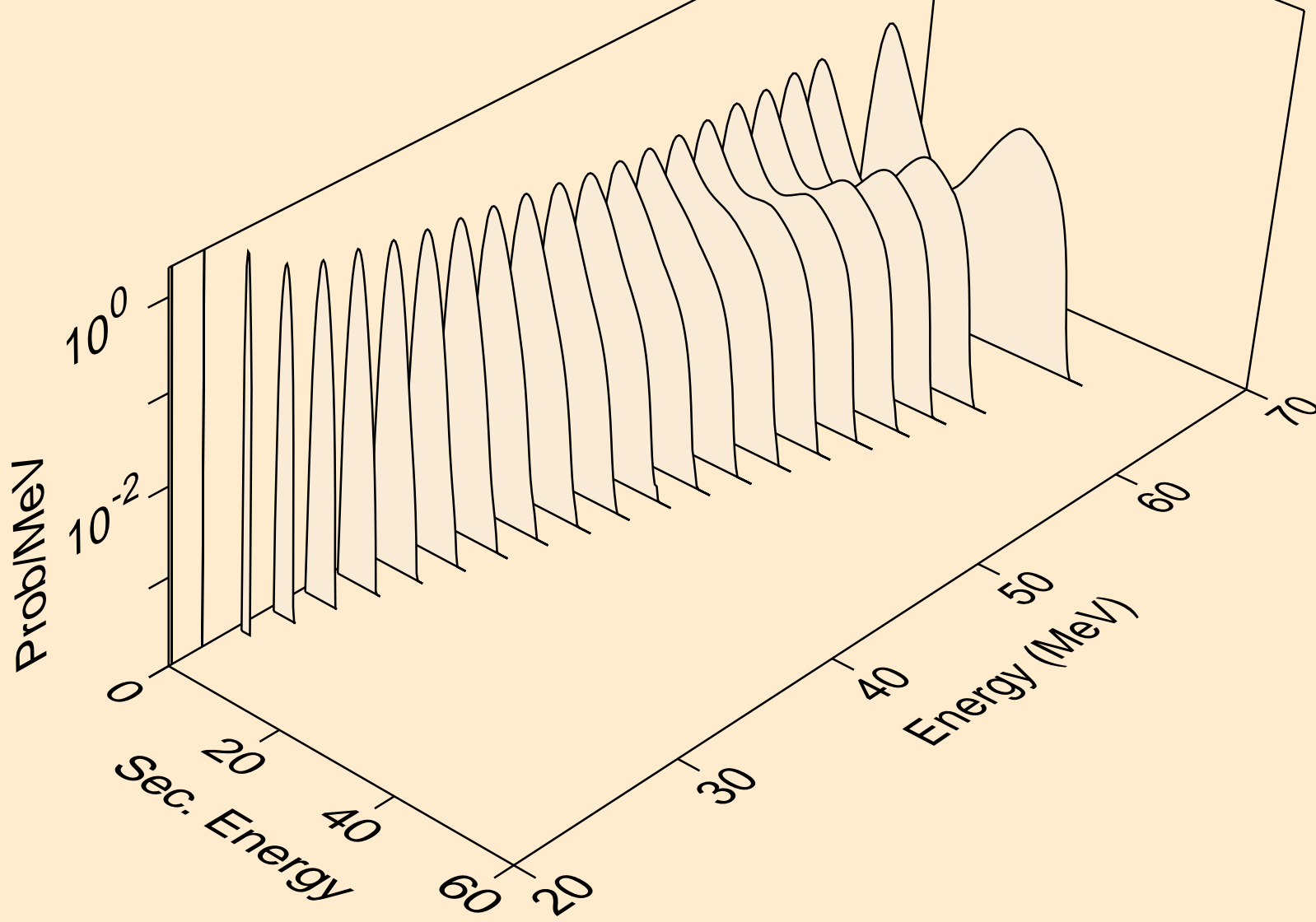

24-CR-54 FOR FENDL-3.2 FROM INDEN-1.0 BY NJOY2016.60+ OI
protons from (n,pt)

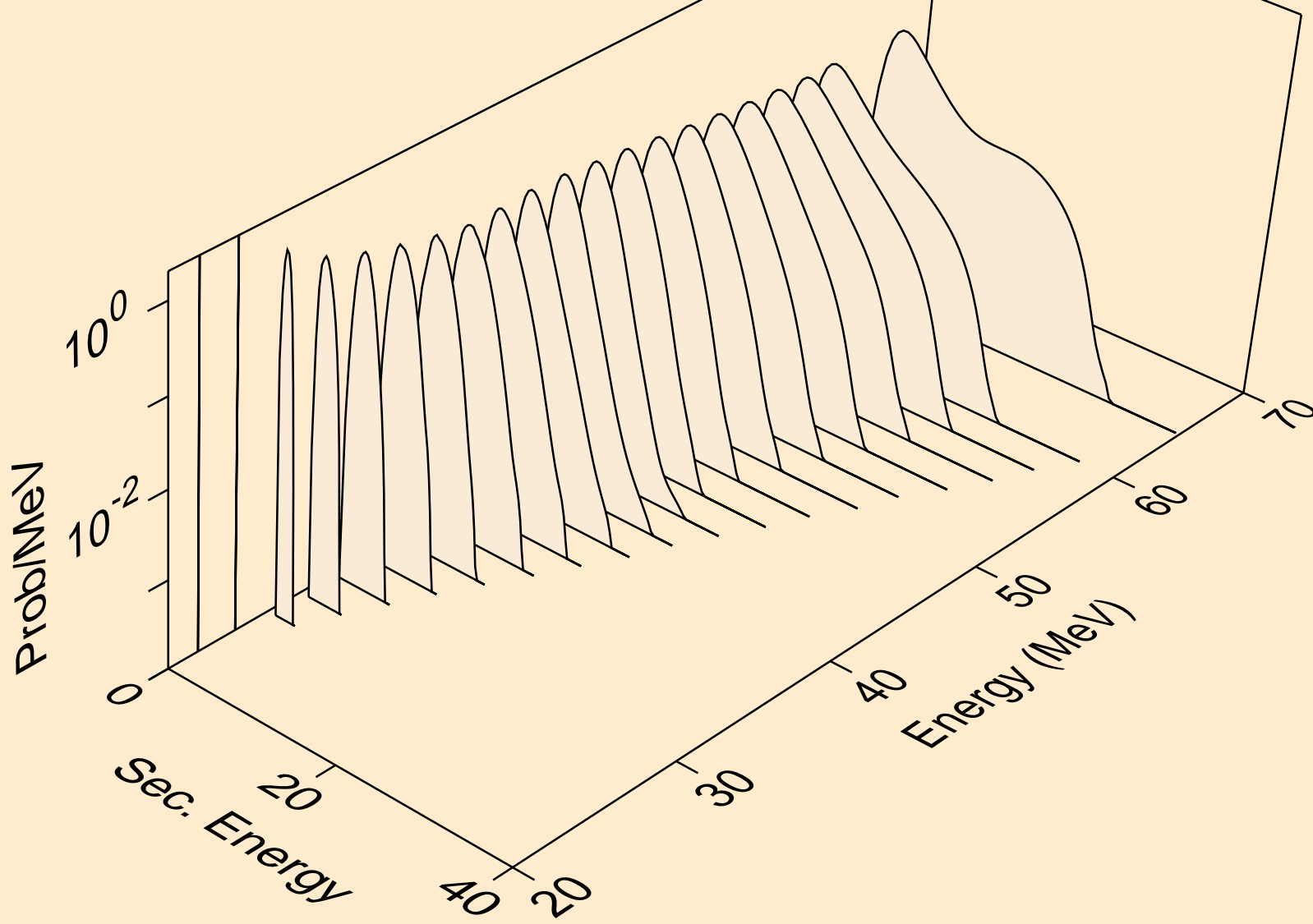

24-CR-54 FOR FENDL-3.2 FROM INDEN-1.0 BY NJOY2016.60+ OI
angular distribution for (n,p*0) proton

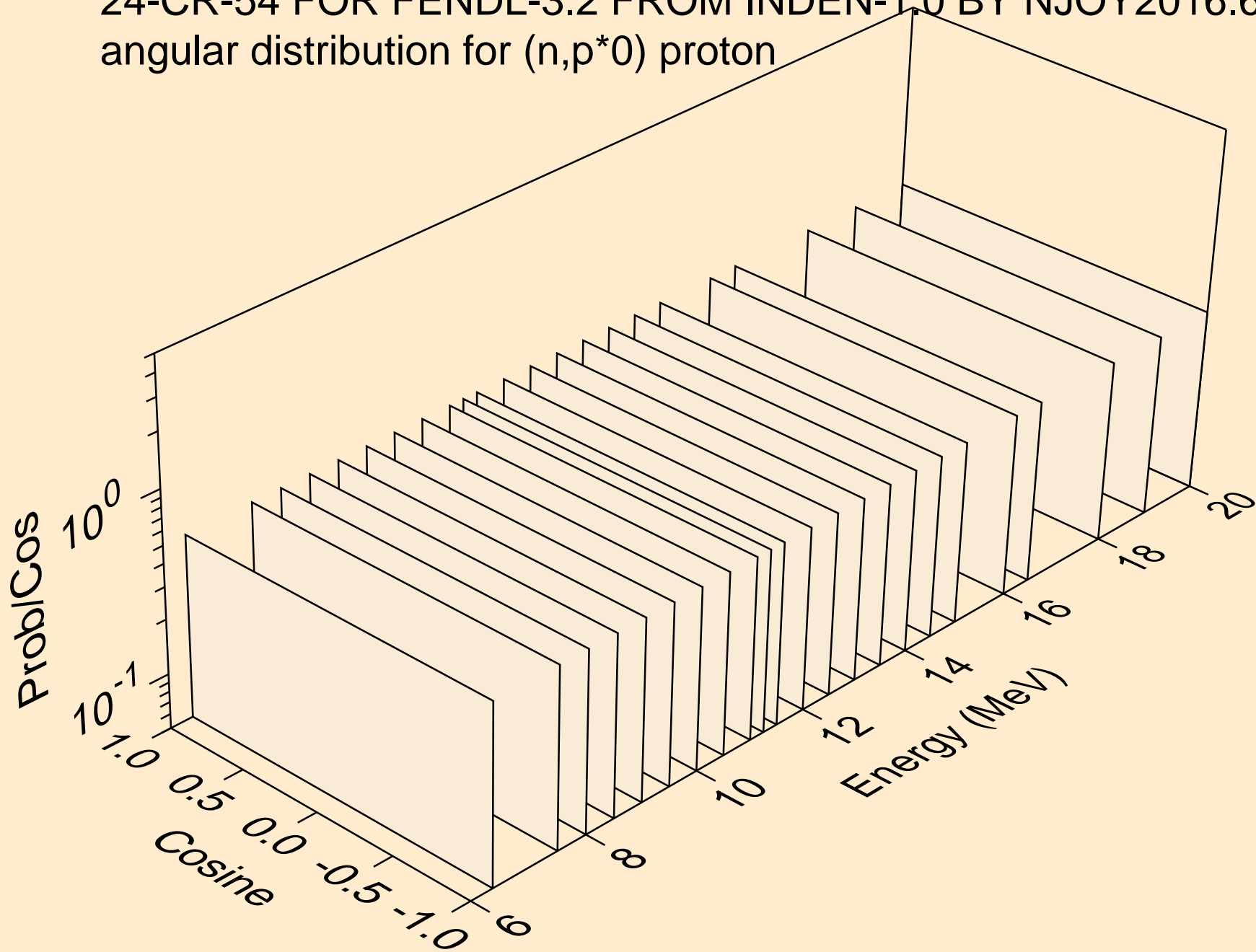

24-CR-54 FOR FENDL-3.2 FROM INDEN-1.0 BY NJOY2016.60+ OI
angular distribution for (n,p*0) proton

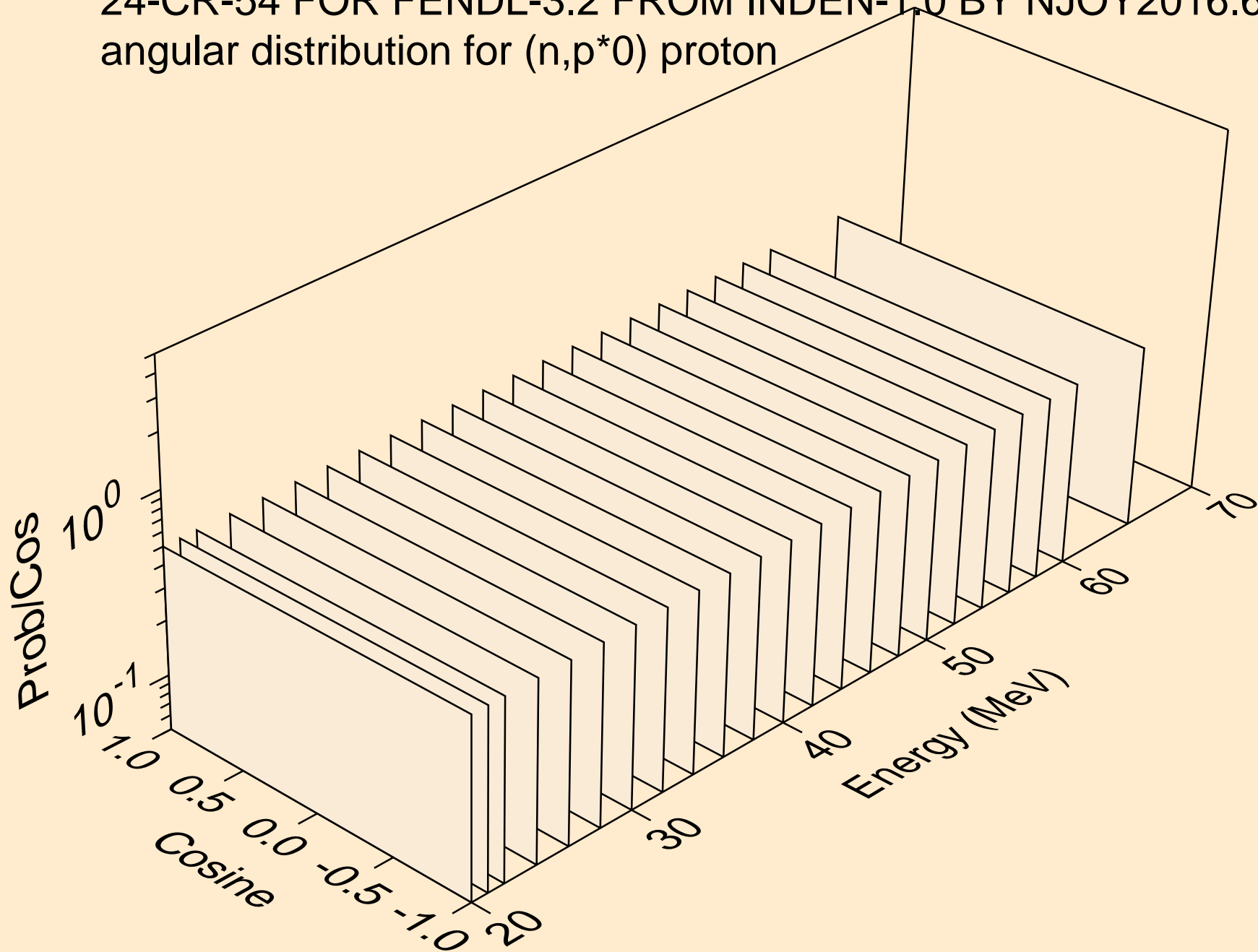

24-CR-54 FOR FENDL-3.2 FROM INDEN-1.0 BY NJOY2016.60+ OI
angular distribution for (n,p*1) proton

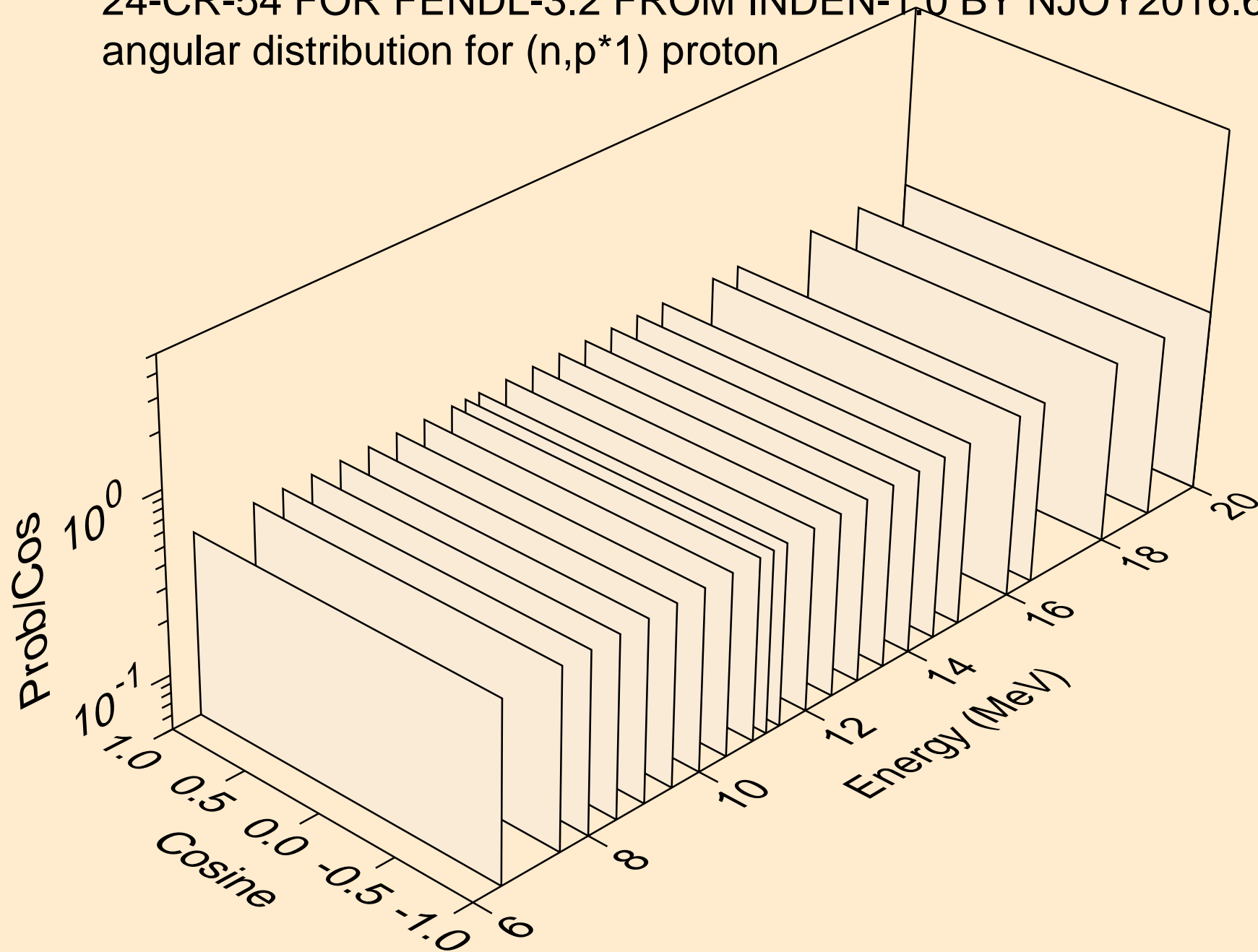

24-CR-54 FOR FENDL-3.2 FROM INDEN-1.0 BY NJOY2016.60+ OI
angular distribution for (n,p*1) proton

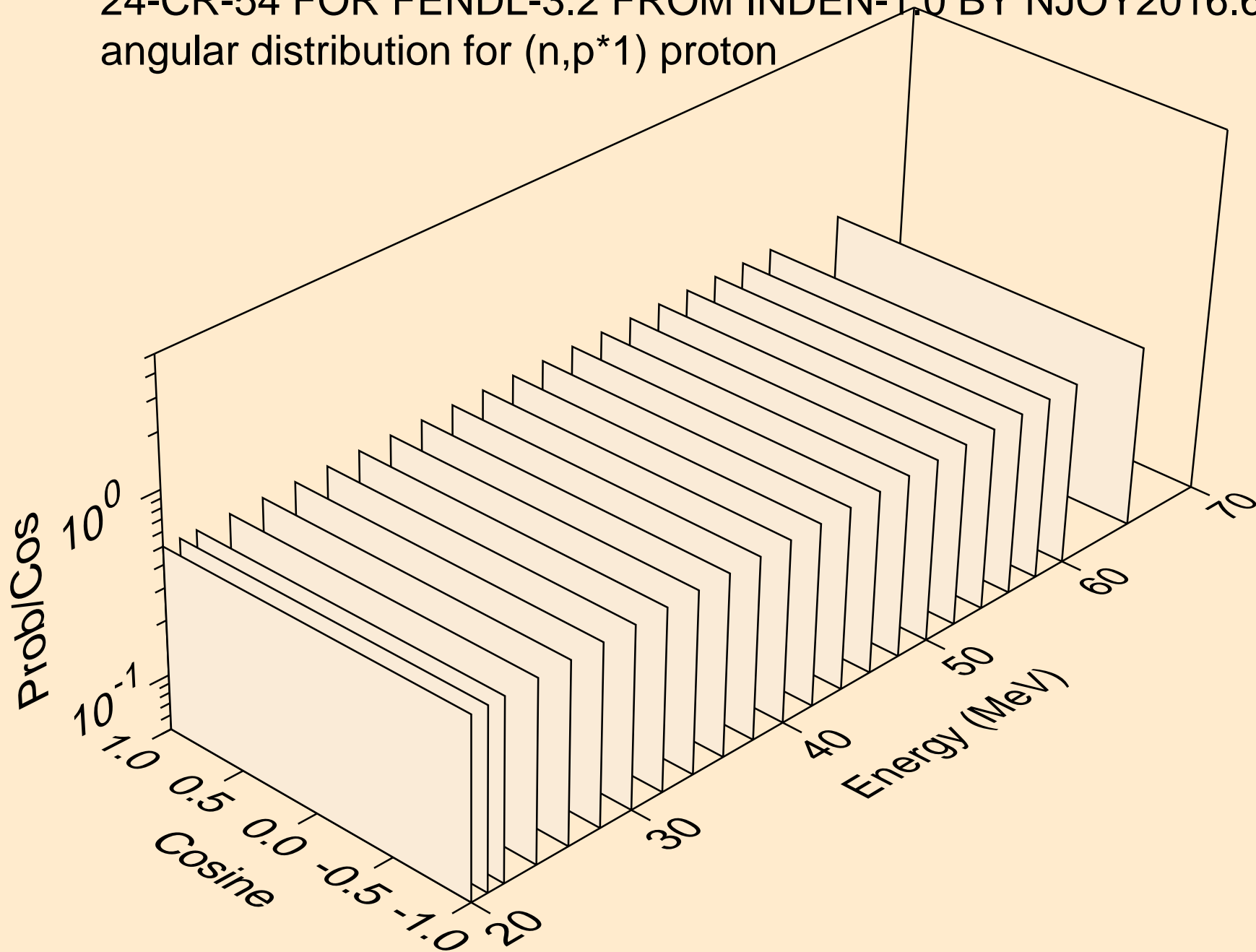

24-CR-54 FOR FENDL-3.2 FROM INDEN-1.0 BY NJOY2016.60+ OI
angular distribution for (n,p*2) proton

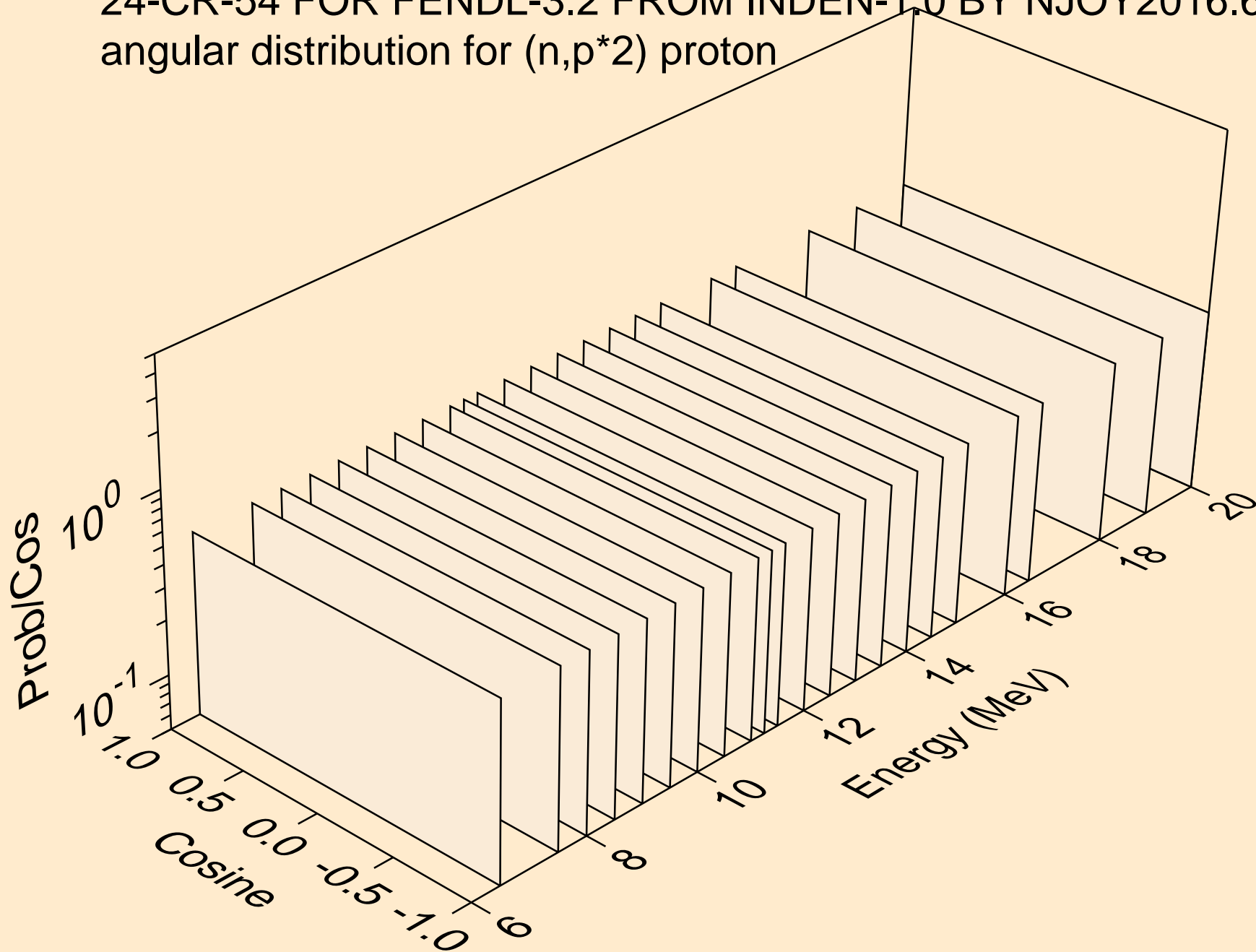

24-CR-54 FOR FENDL-3.2 FROM INDEN-1.0 BY NJOY2016.60+ OI
angular distribution for (n,p*2) proton

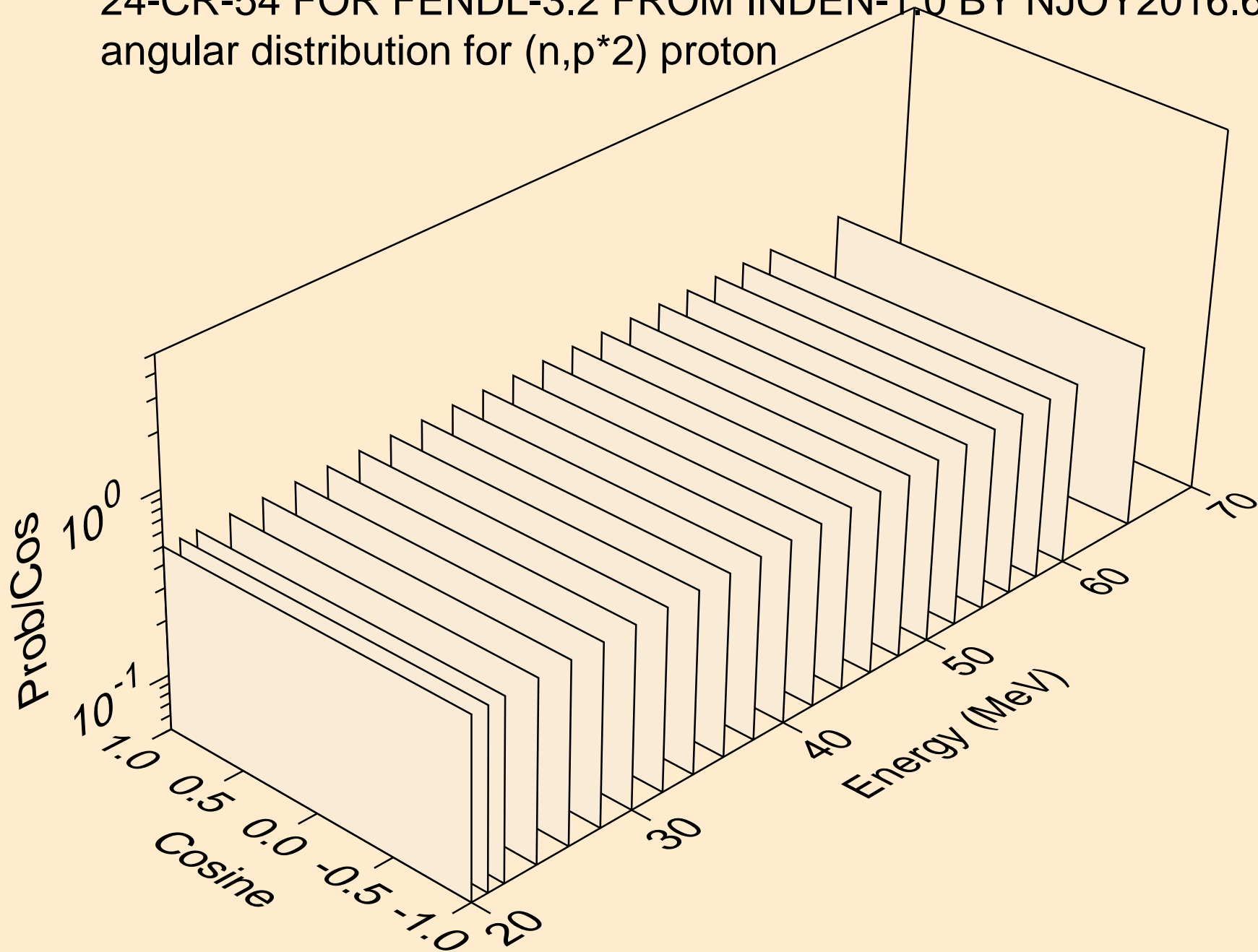

24-CR-54 FOR FENDL-3.2 FROM INDEN-1.0 BY NJOY2016.60+ OI
angular distribution for (n,p*3) proton

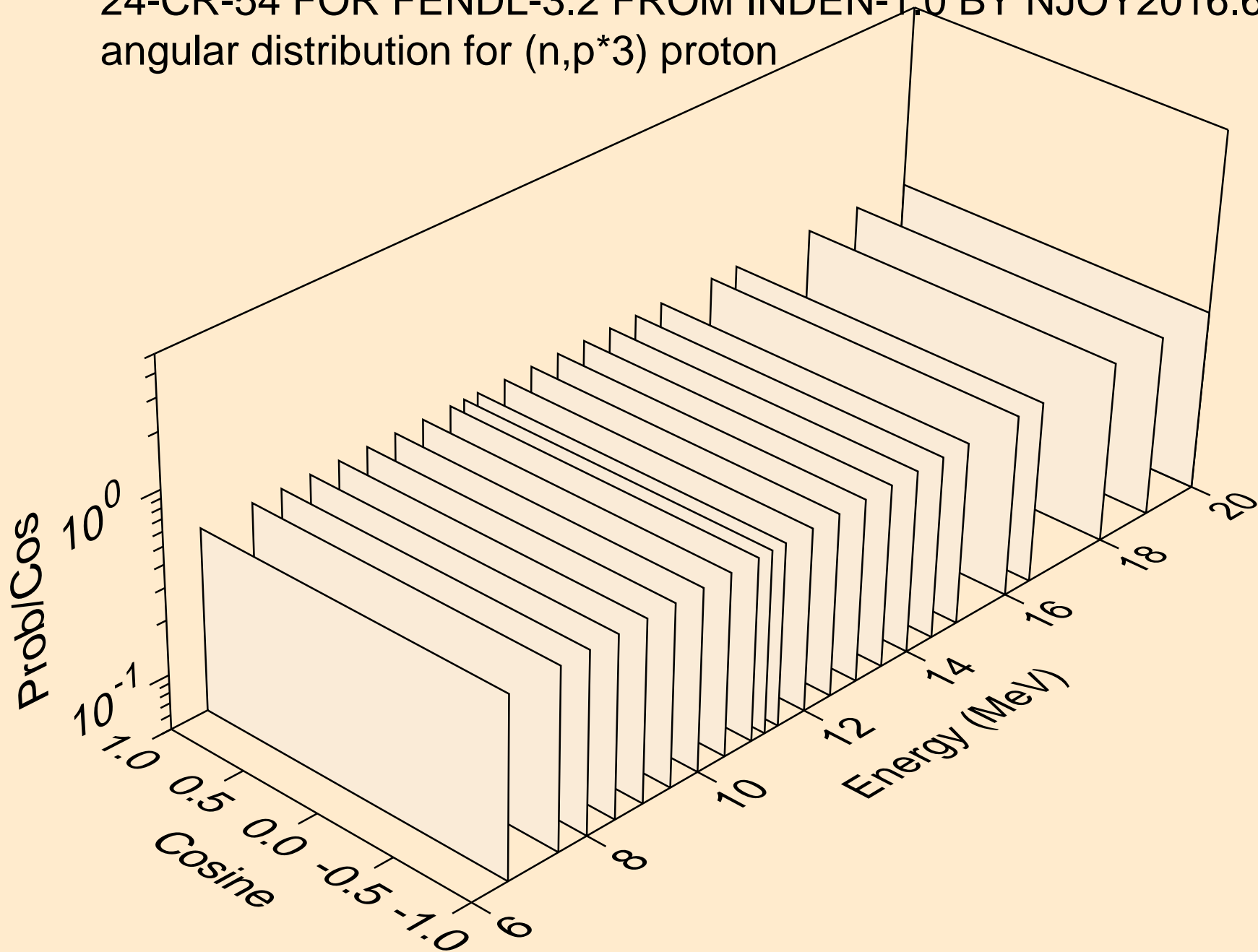

24-CR-54 FOR FENDL-3.2 FROM INDEN-1.0 BY NJOY2016.60+ OI
angular distribution for (n,p*3) proton

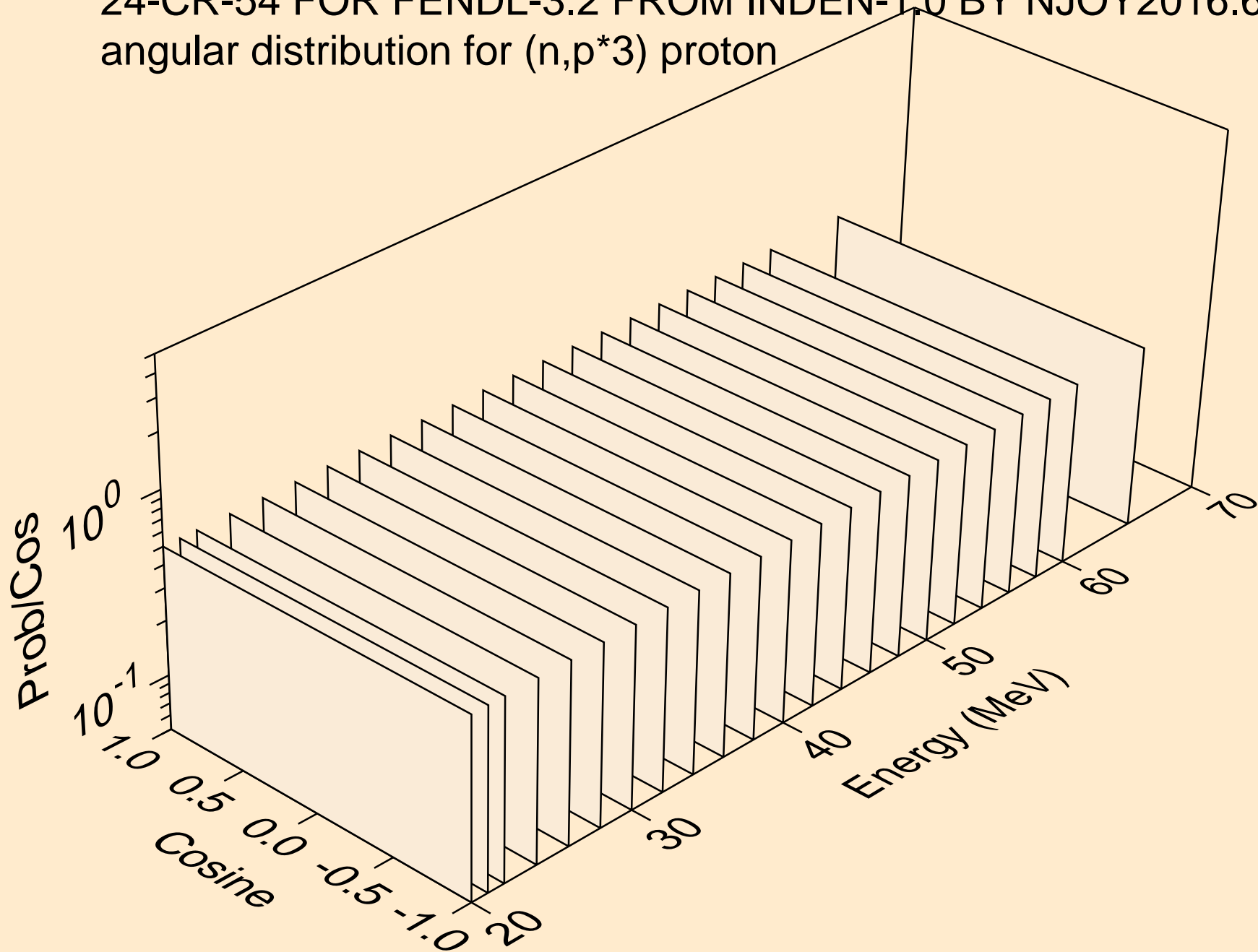

24-CR-54 FOR FENDL-3.2 FROM INDEN-1.0 BY NJOY2016.60+ OI
angular distribution for (n,p*4) proton

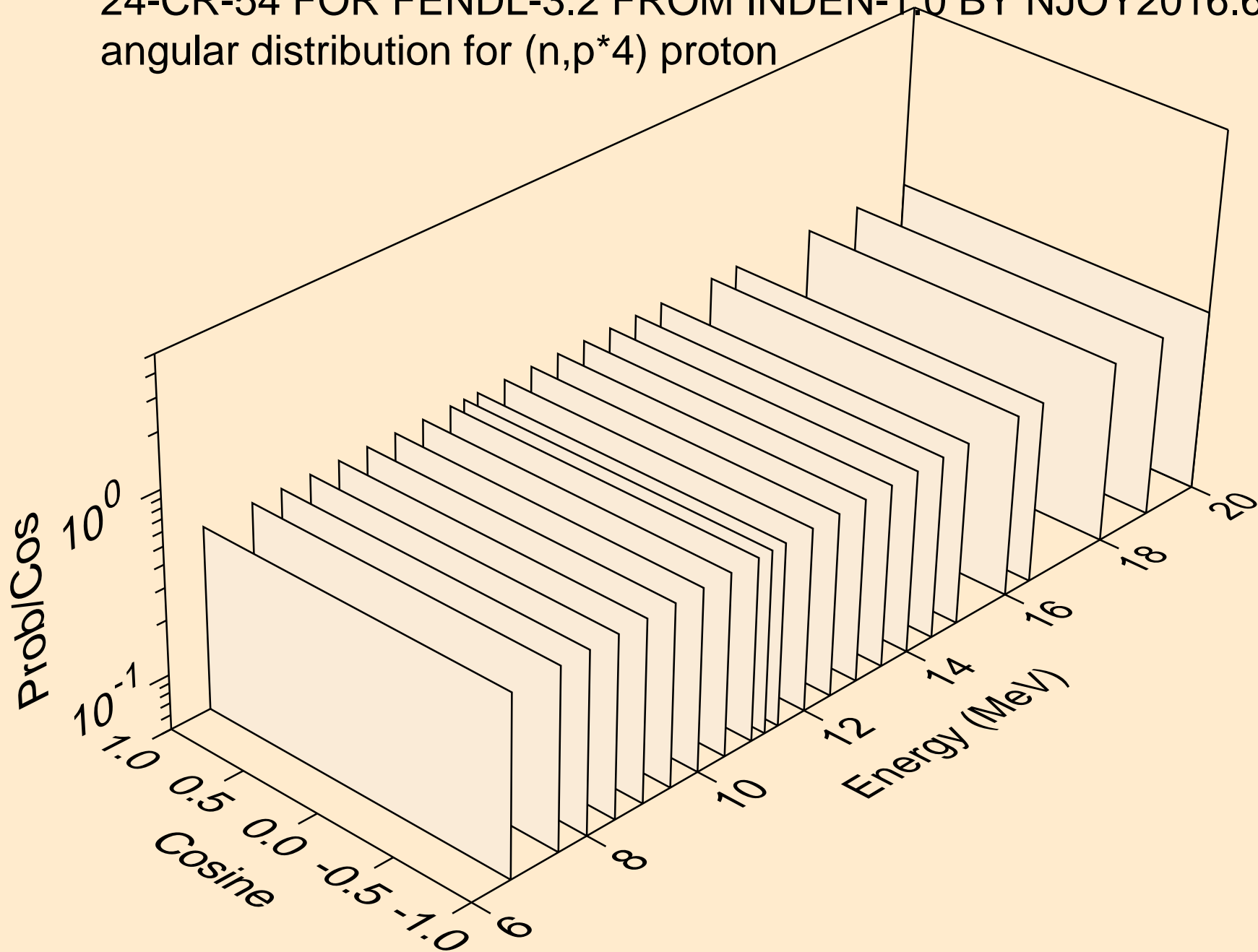

24-CR-54 FOR FENDL-3.2 FROM INDEN-1.0 BY NJOY2016.60+ OI
angular distribution for (n,p*4) proton

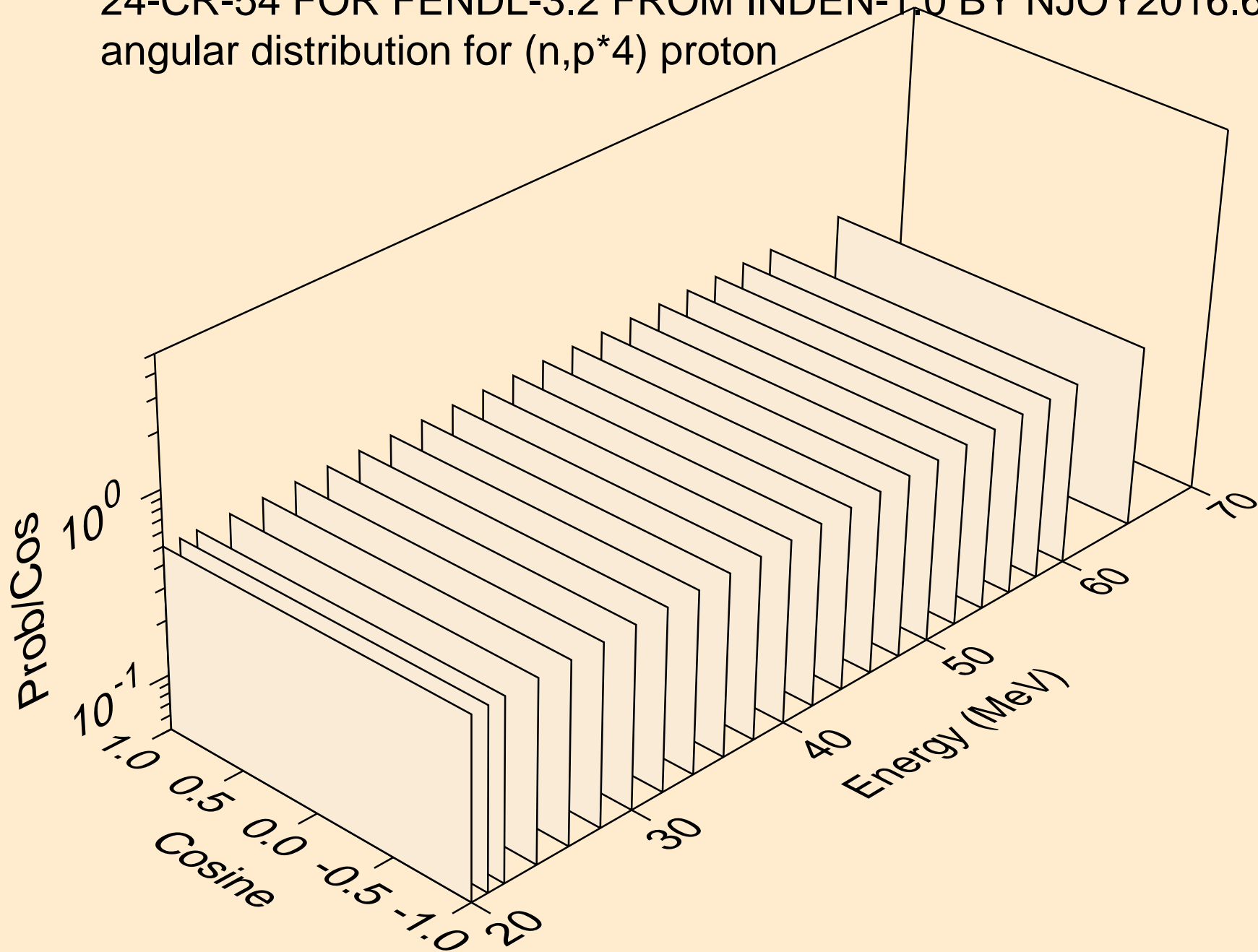

24-CR-54 FOR FENDL-3.2 FROM INDEN-1.0 BY NJOY2016.60+ OI
angular distribution for (n,p*5) proton

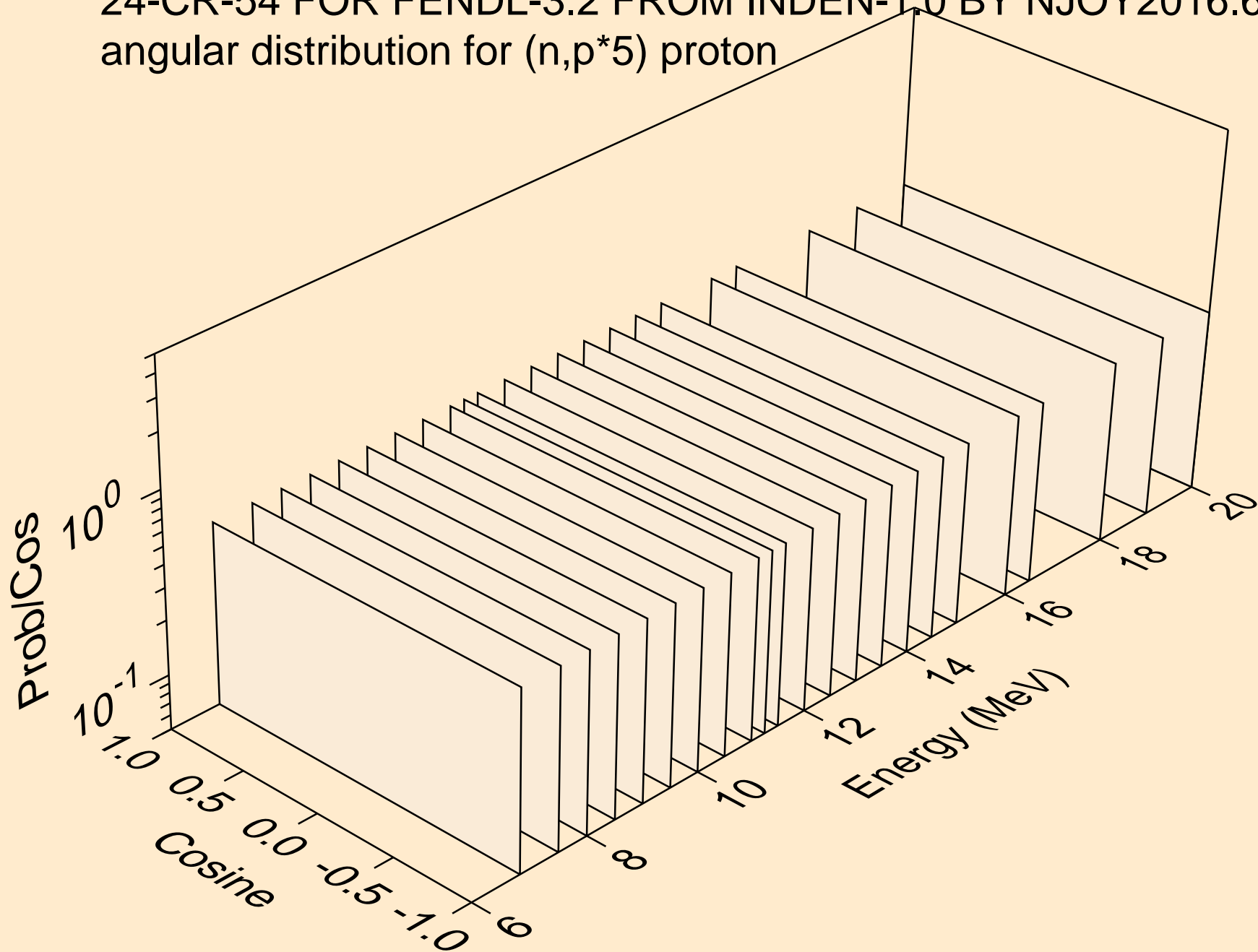

24-CR-54 FOR FENDL-3.2 FROM INDEN-1.0 BY NJOY2016.60+ OI
angular distribution for (n,p*5) proton

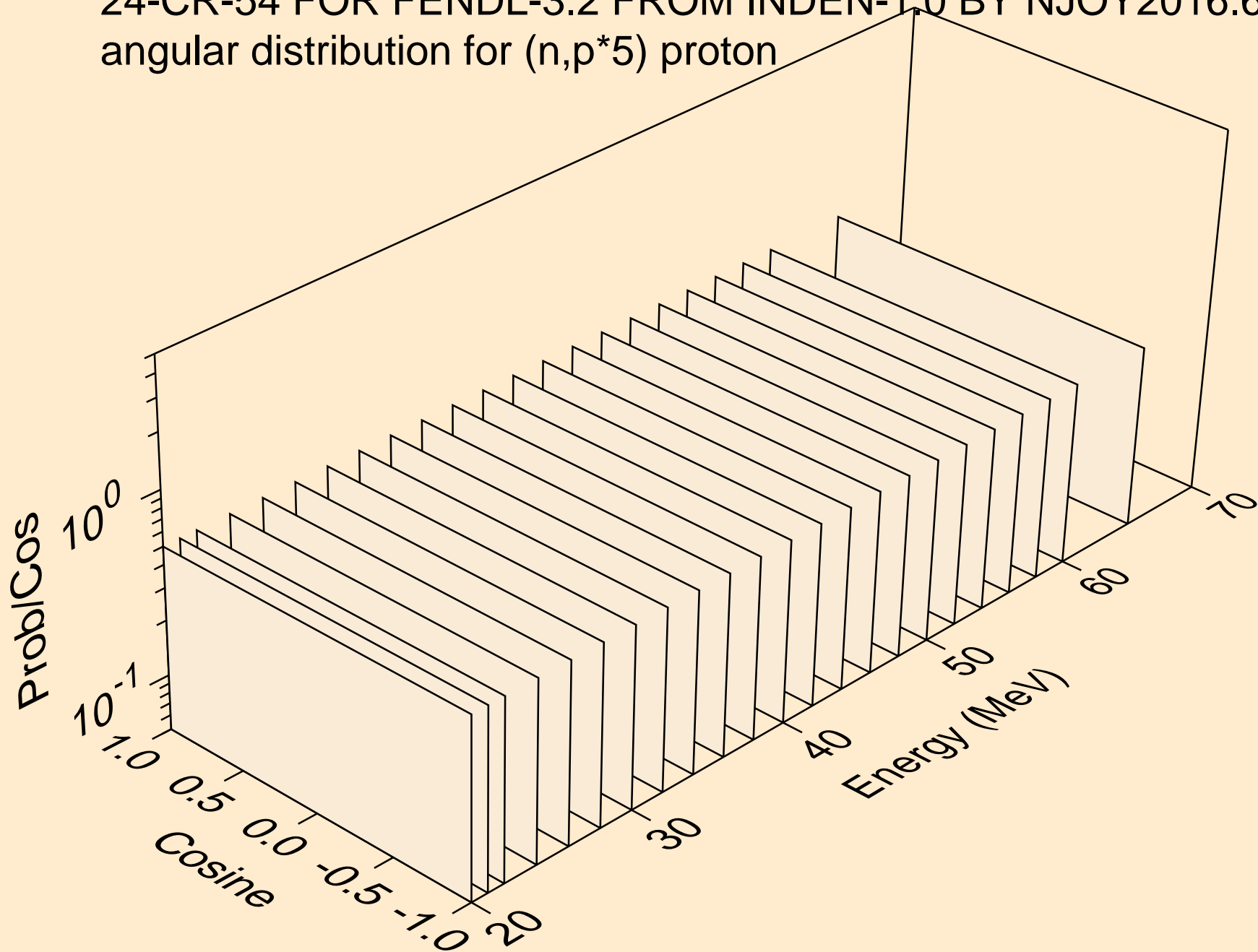

24-CR-54 FOR FENDL-3.2 FROM INDEN-1.0 BY NJOY2016.60+ OI
angular distribution for (n,p*6) proton

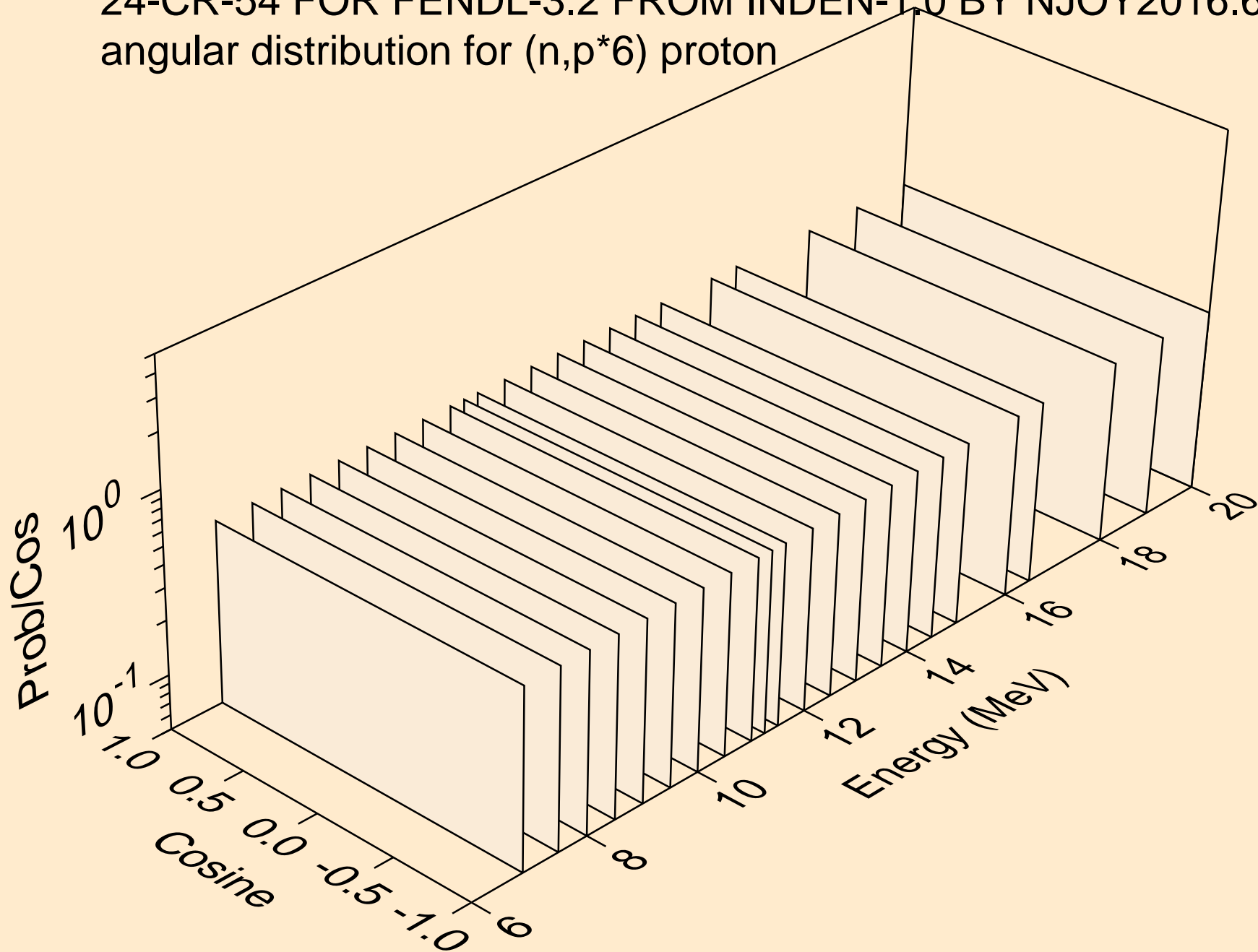

24-CR-54 FOR FENDL-3.2 FROM INDEN-1.0 BY NJOY2016.60+ OI
angular distribution for (n,p*6) proton

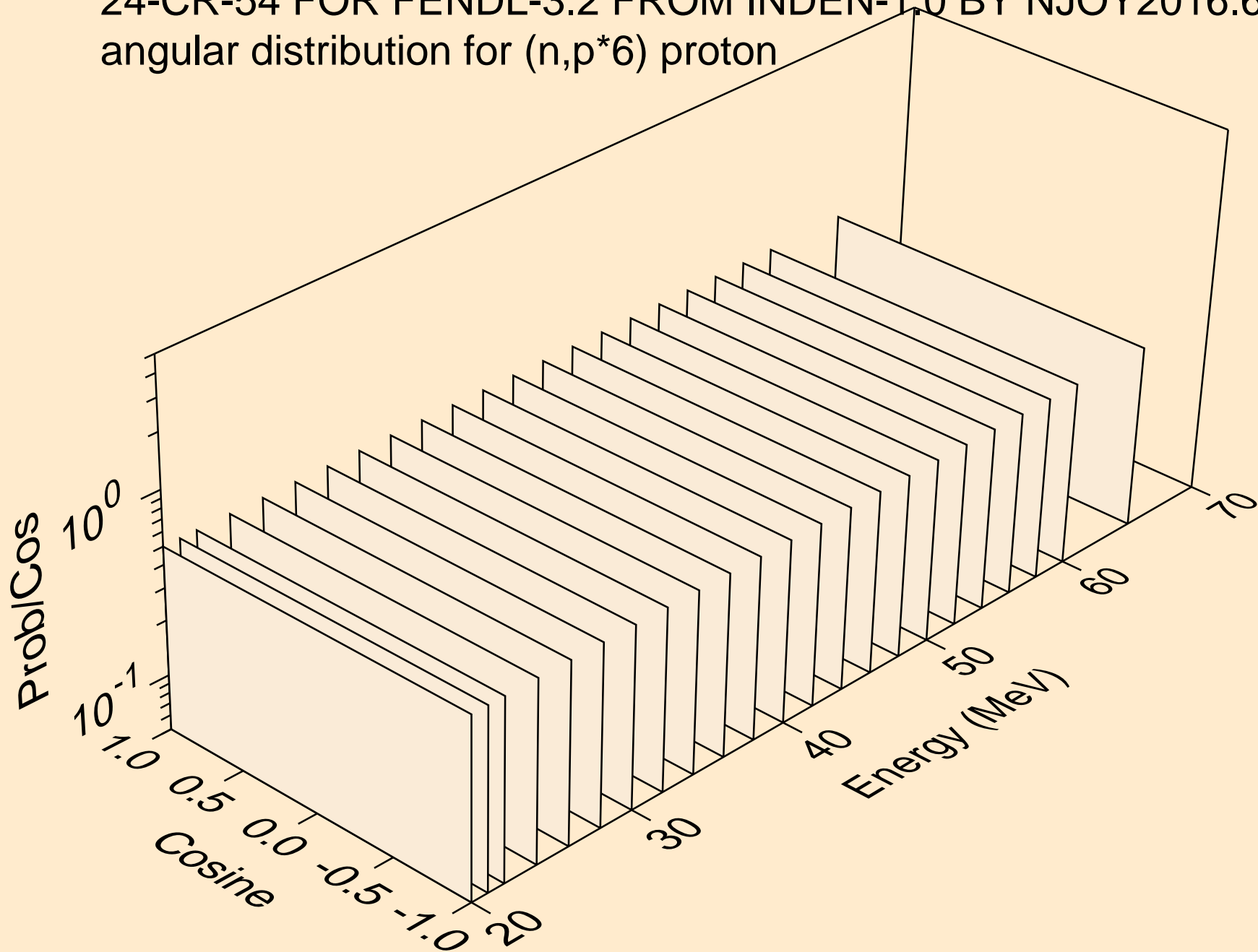

24-CR-54 FOR FENDL-3.2 FROM INDEN-1.0 BY NJOY2016.60+ OI
angular distribution for (n,p*7) proton

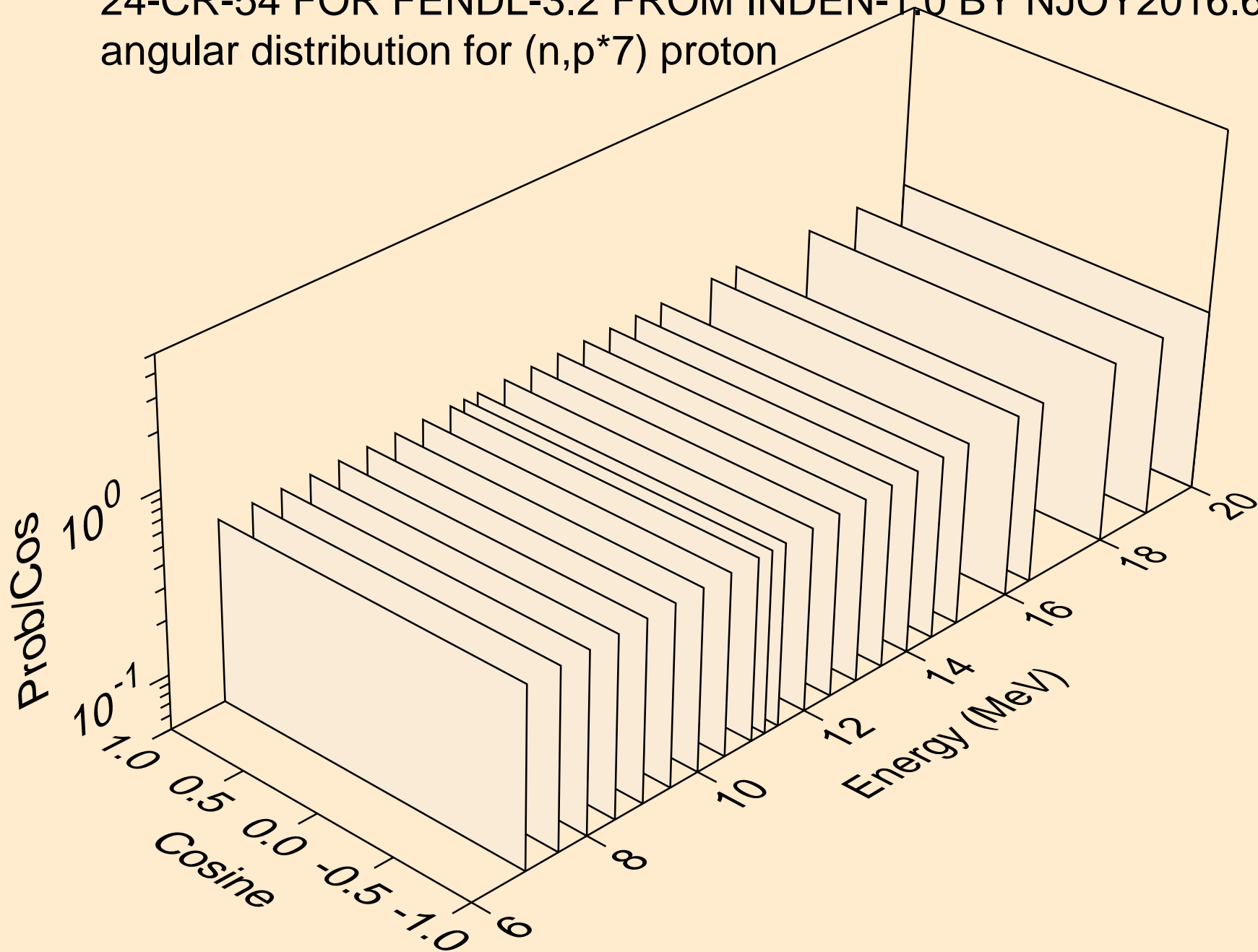

24-CR-54 FOR FENDL-3.2 FROM INDEN-1.0 BY NJOY2016.60+ OI
angular distribution for (n,p*7) proton

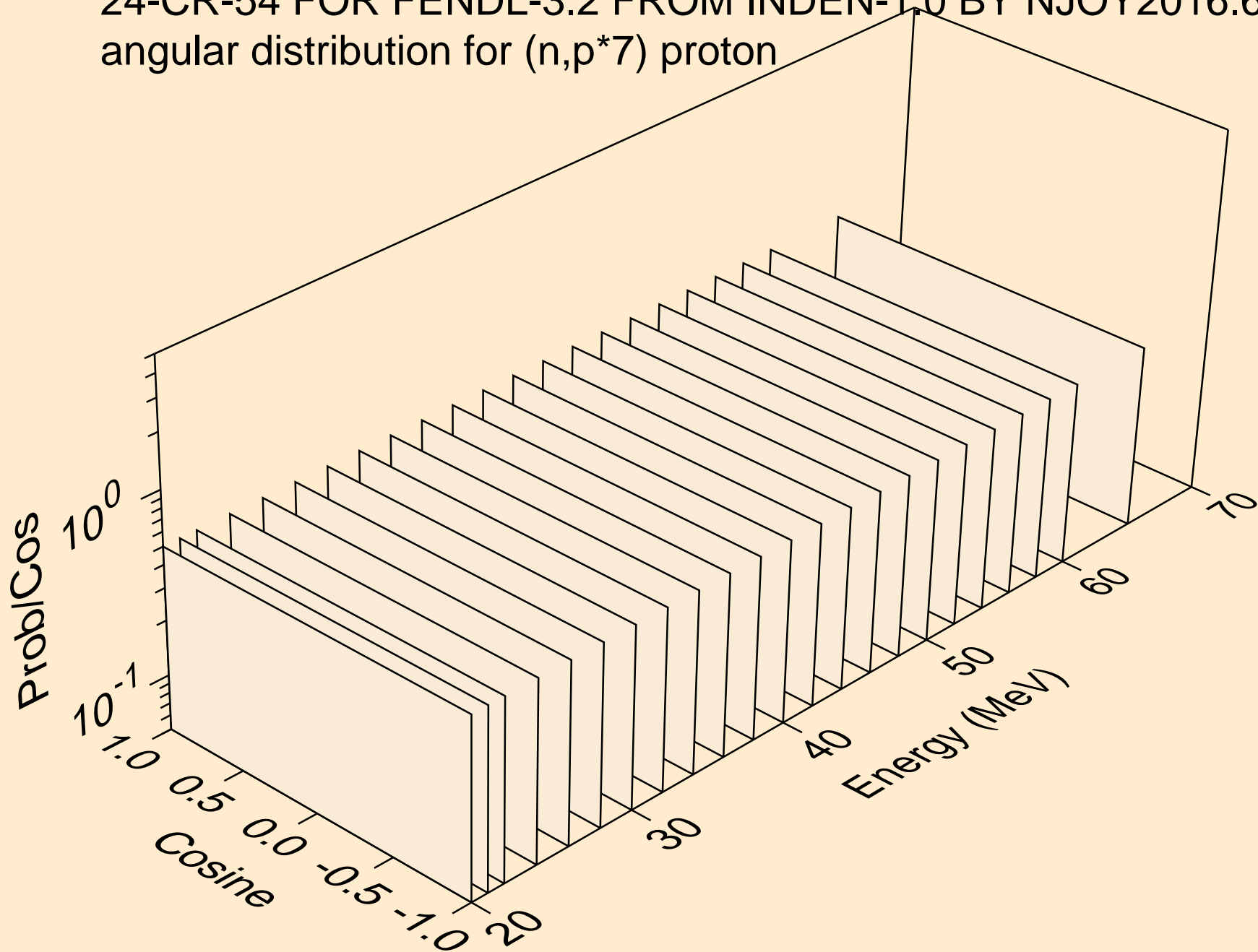

24-CR-54 FOR FENDL-3.2 FROM INDEN-1.0 BY NJOY2016.60+ OI
angular distribution for (n,p*8) proton

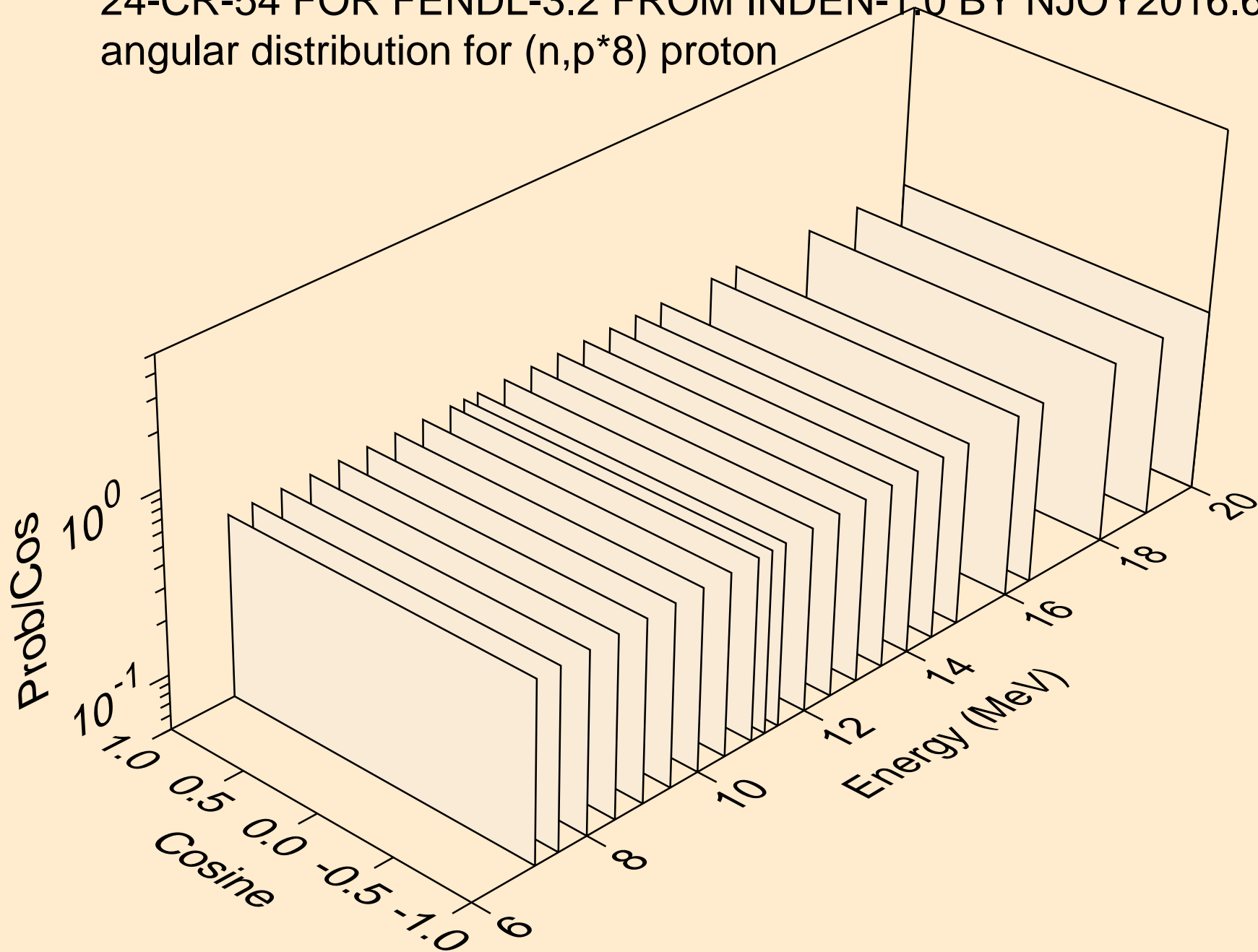

24-CR-54 FOR FENDL-3.2 FROM INDEN-1.0 BY NJOY2016.60+ OI
angular distribution for (n,p*8) proton

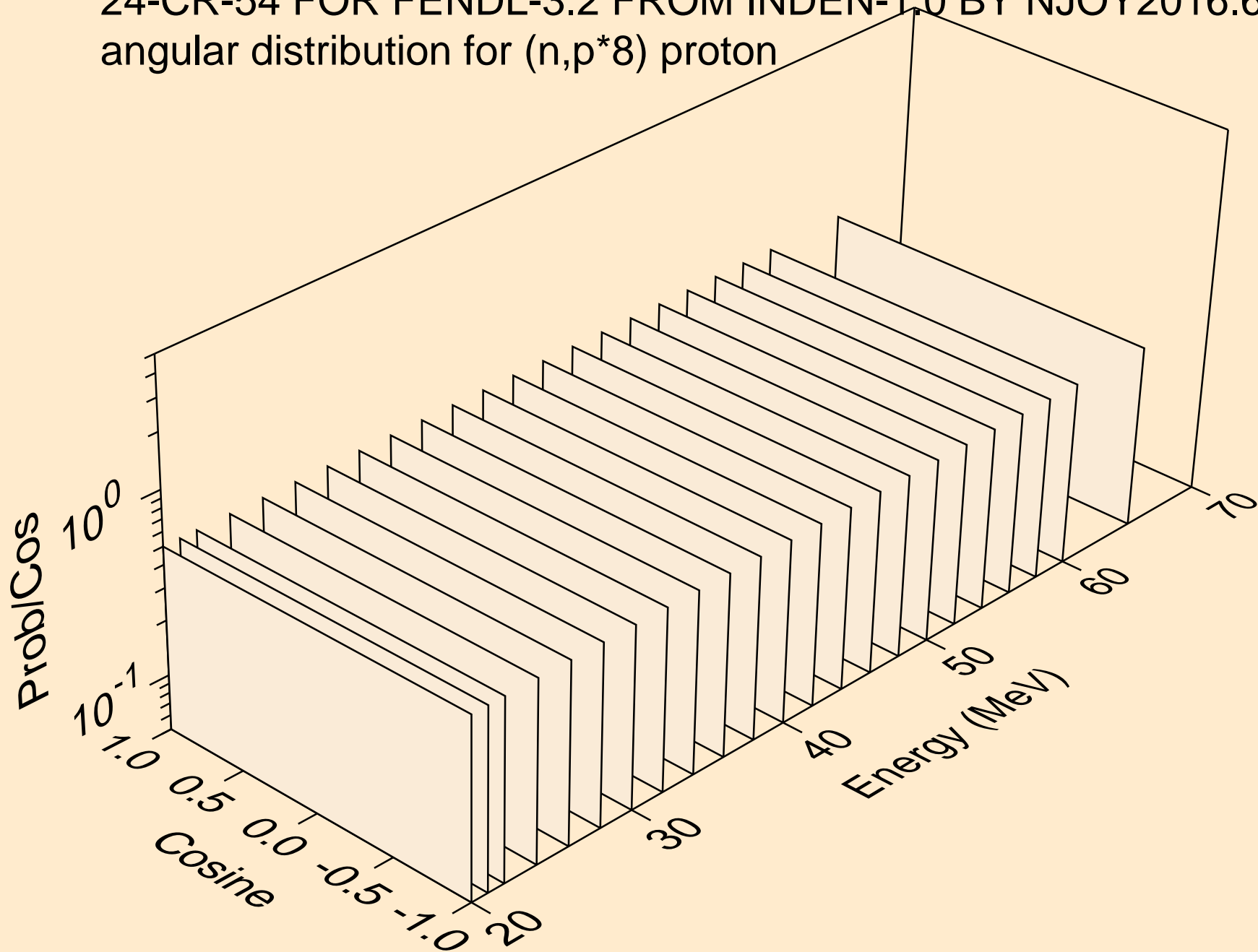

24-CR-54 FOR FENDL-3.2 FROM INDEN-1.0 BY NJOY2016.60+ OI
angular distribution for (n,p*9) proton

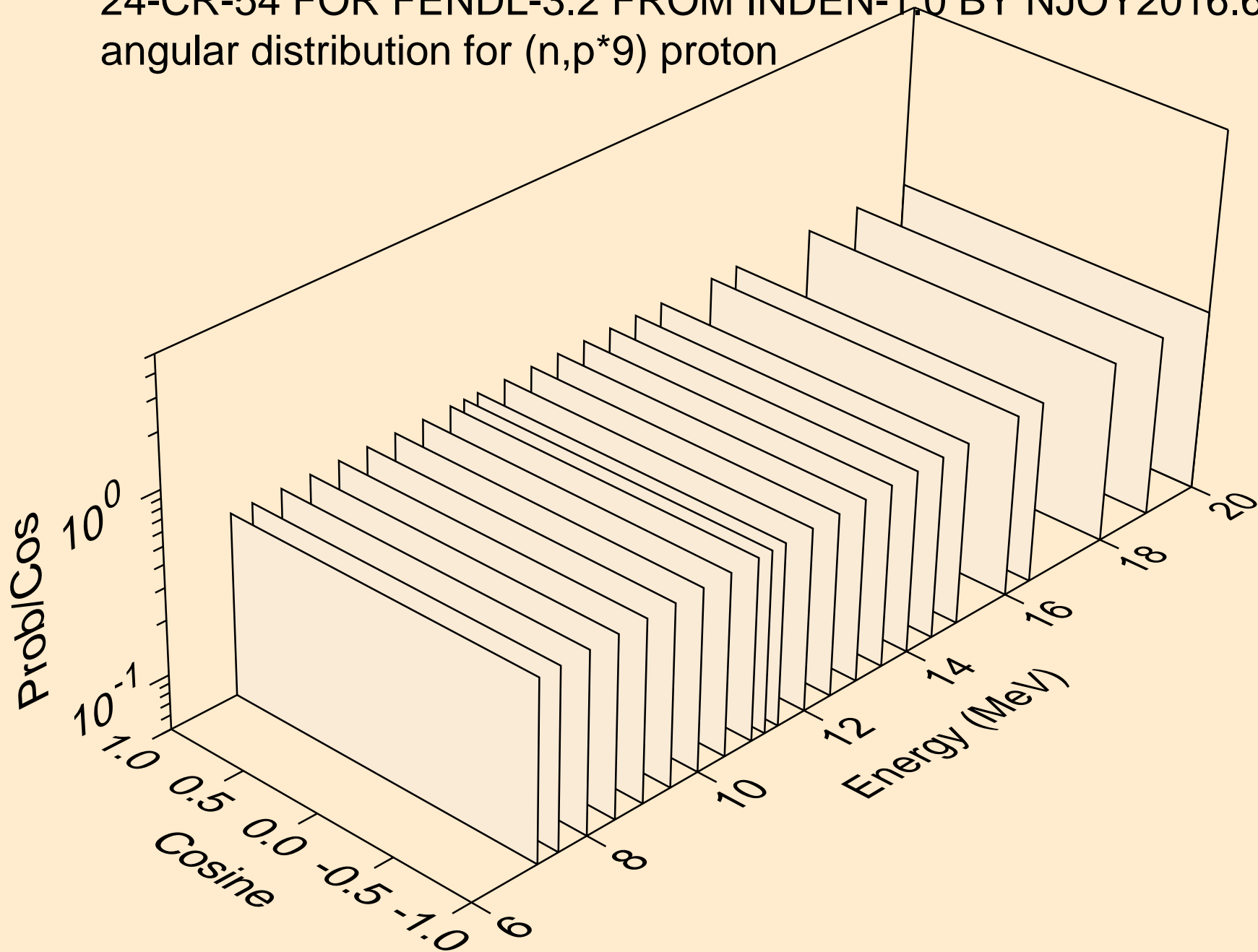

24-CR-54 FOR FENDL-3.2 FROM INDEN-1.0 BY NJOY2016.60+ OI
angular distribution for (n,p*9) proton

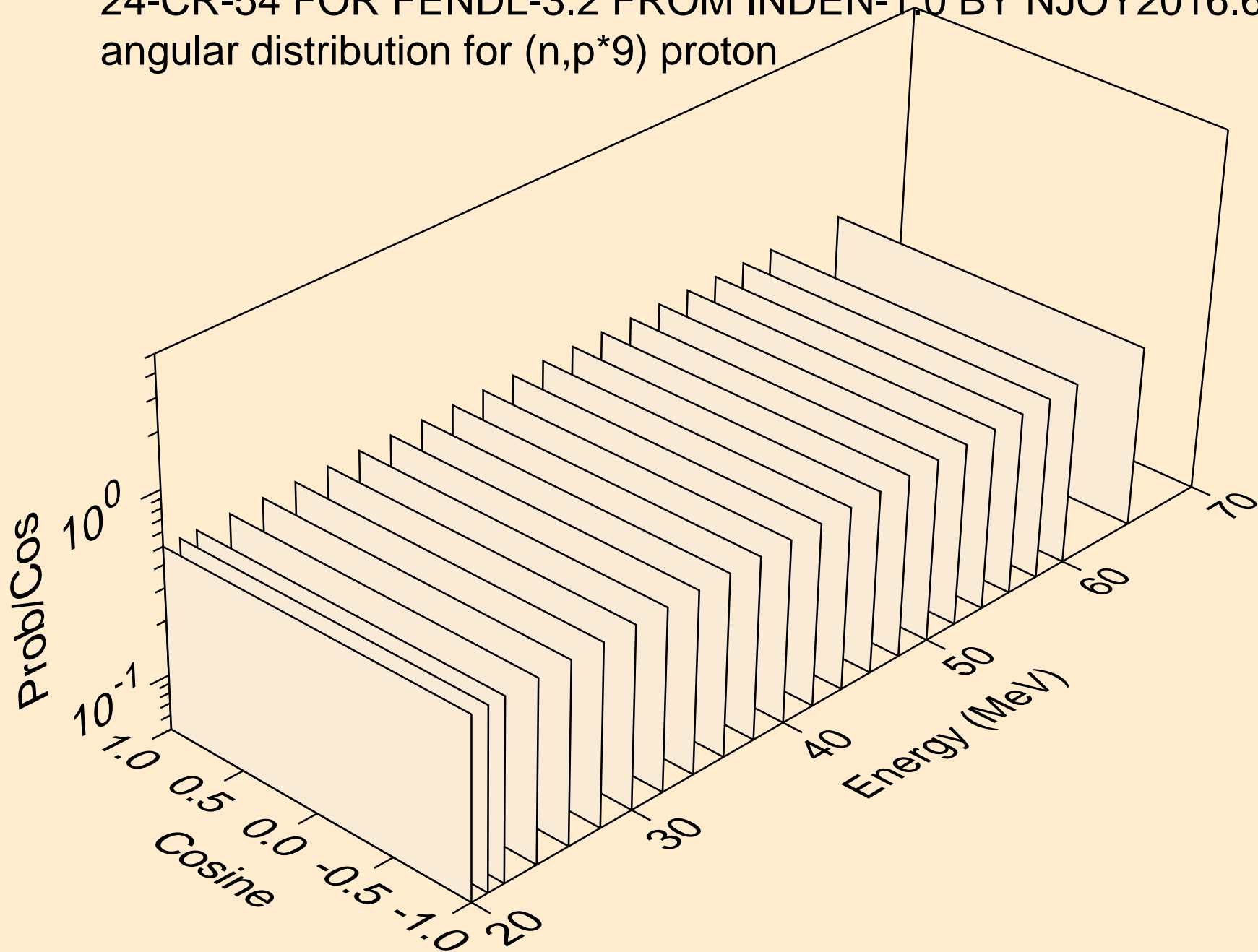

24-CR-54 FOR FENDL-3.2 FROM INDEN-1.0 BY NJOY2016.60+ OI
angular distribution for (n,p*10) proton

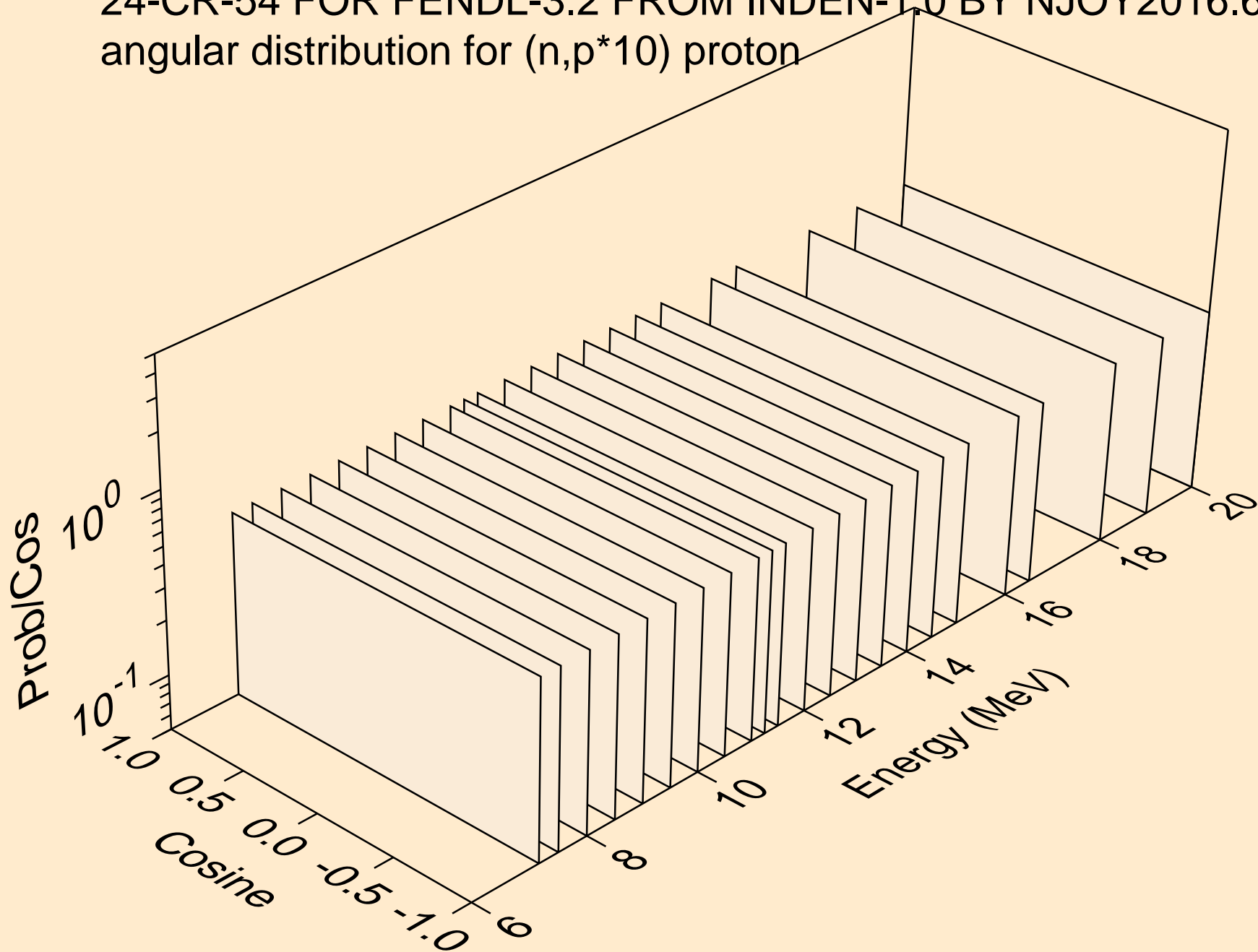

24-CR-54 FOR FENDL-3.2 FROM INDEN-1.0 BY NJOY2016.60+ OI
angular distribution for (n,p*10) proton

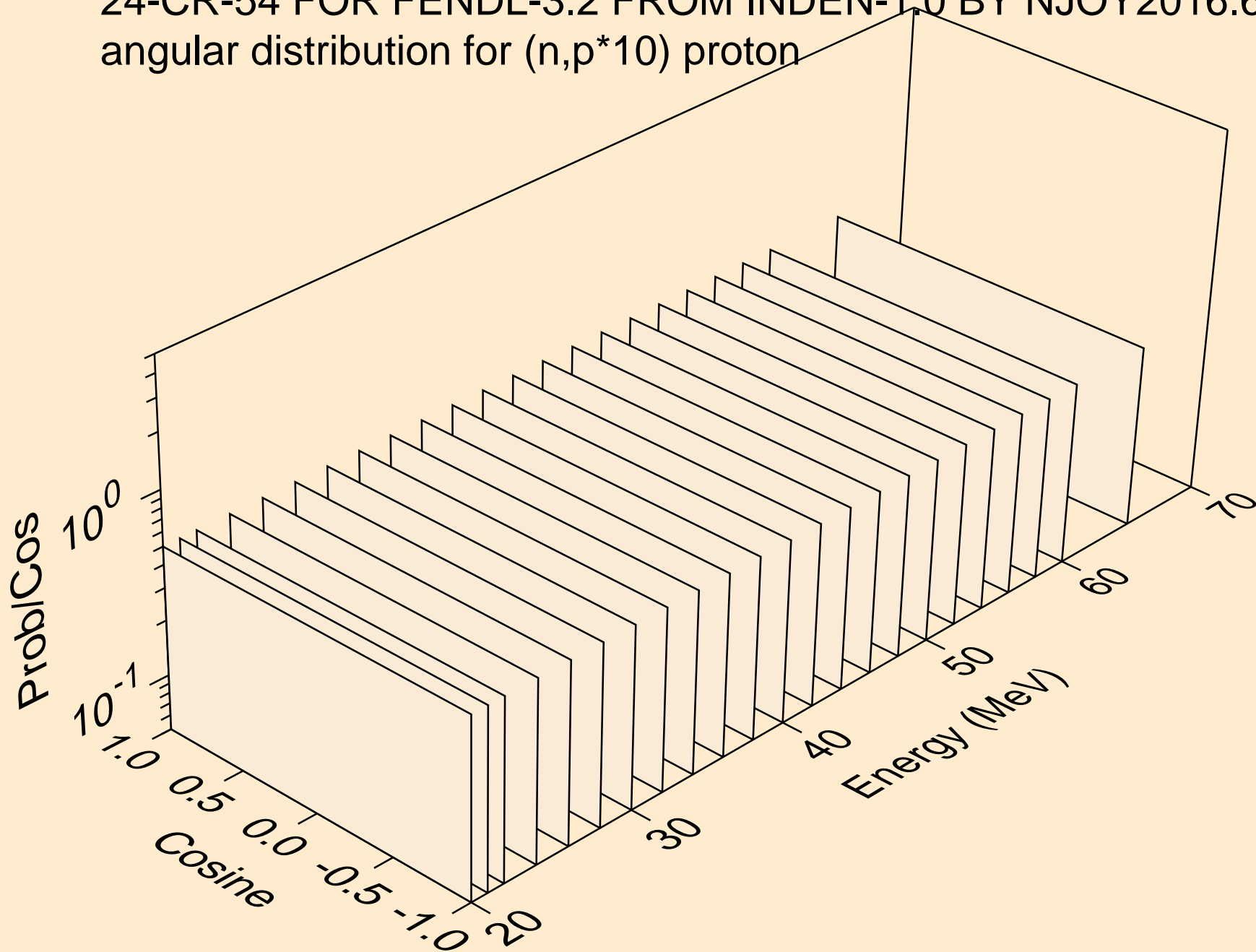

24-CR-54 FOR FENDL-3.2 FROM INDEN-1.0 BY NJOY2016.60+ OI
angular distribution for (n,p*11) proton

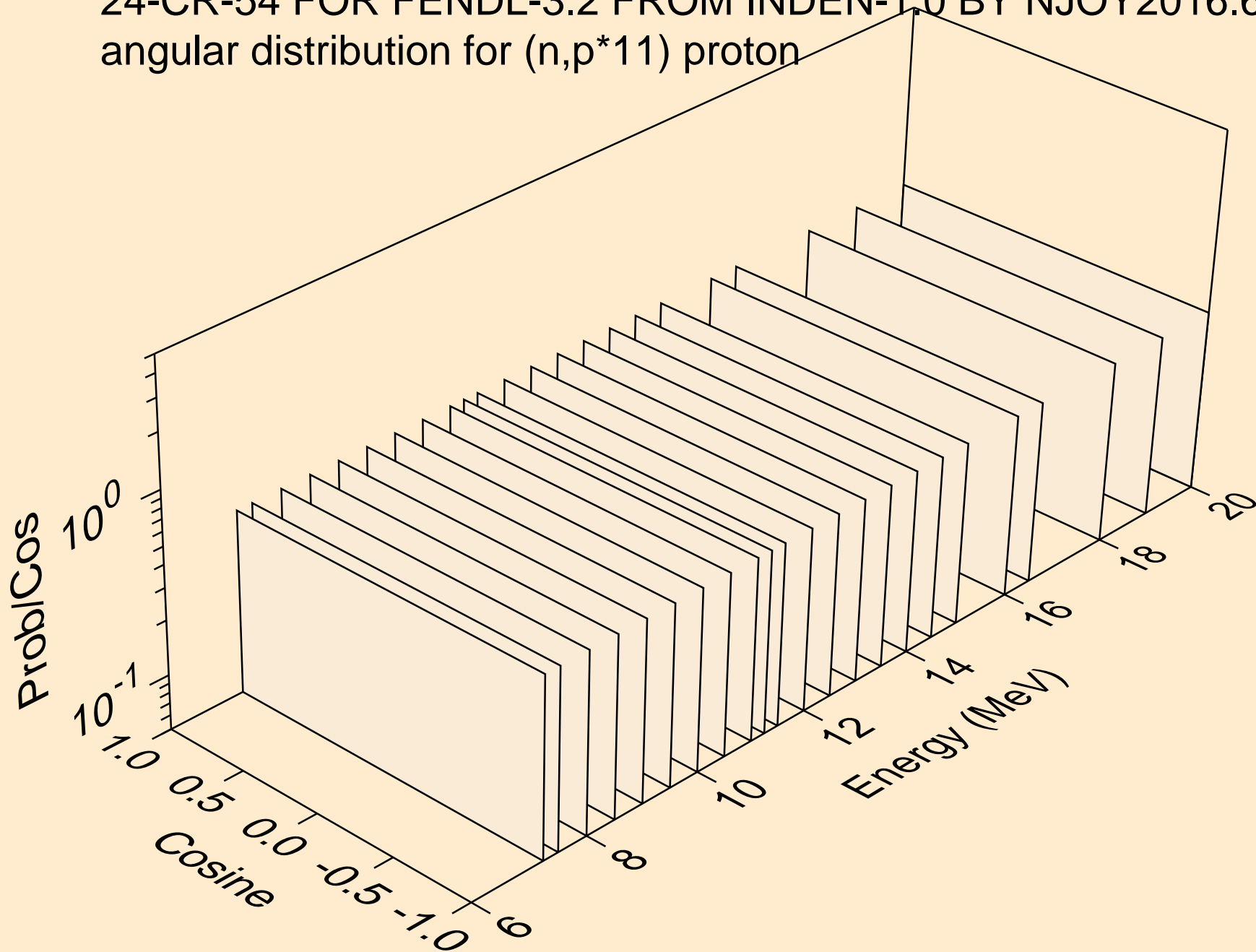

24-CR-54 FOR FENDL-3.2 FROM INDEN-1.0 BY NJOY2016.60+ OI
angular distribution for (n,p*11) proton

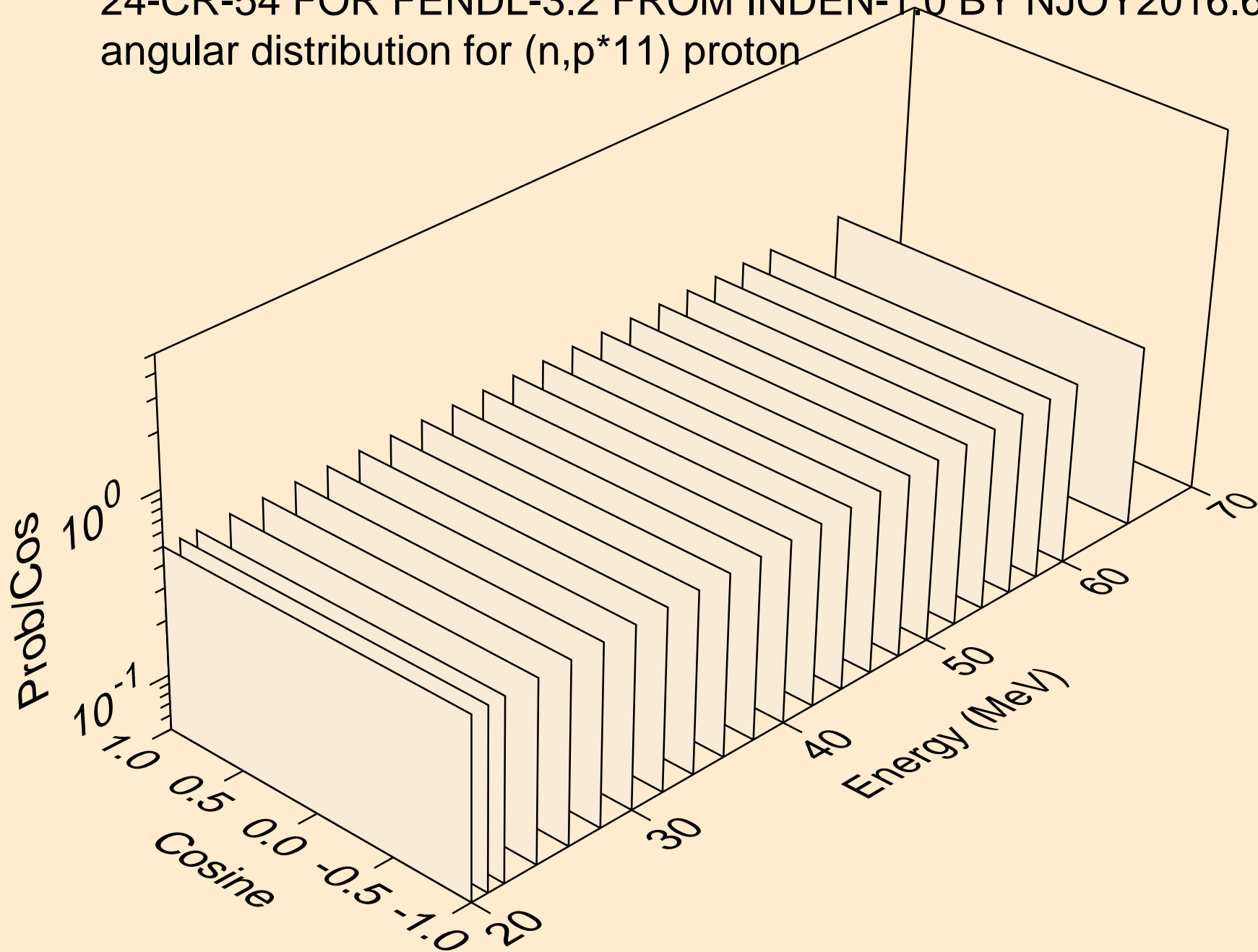

24-CR-54 FOR FENDL-3.2 FROM INDEN-1.0 BY NJOY2016.60+ OI
angular distribution for (n,p*12) proton

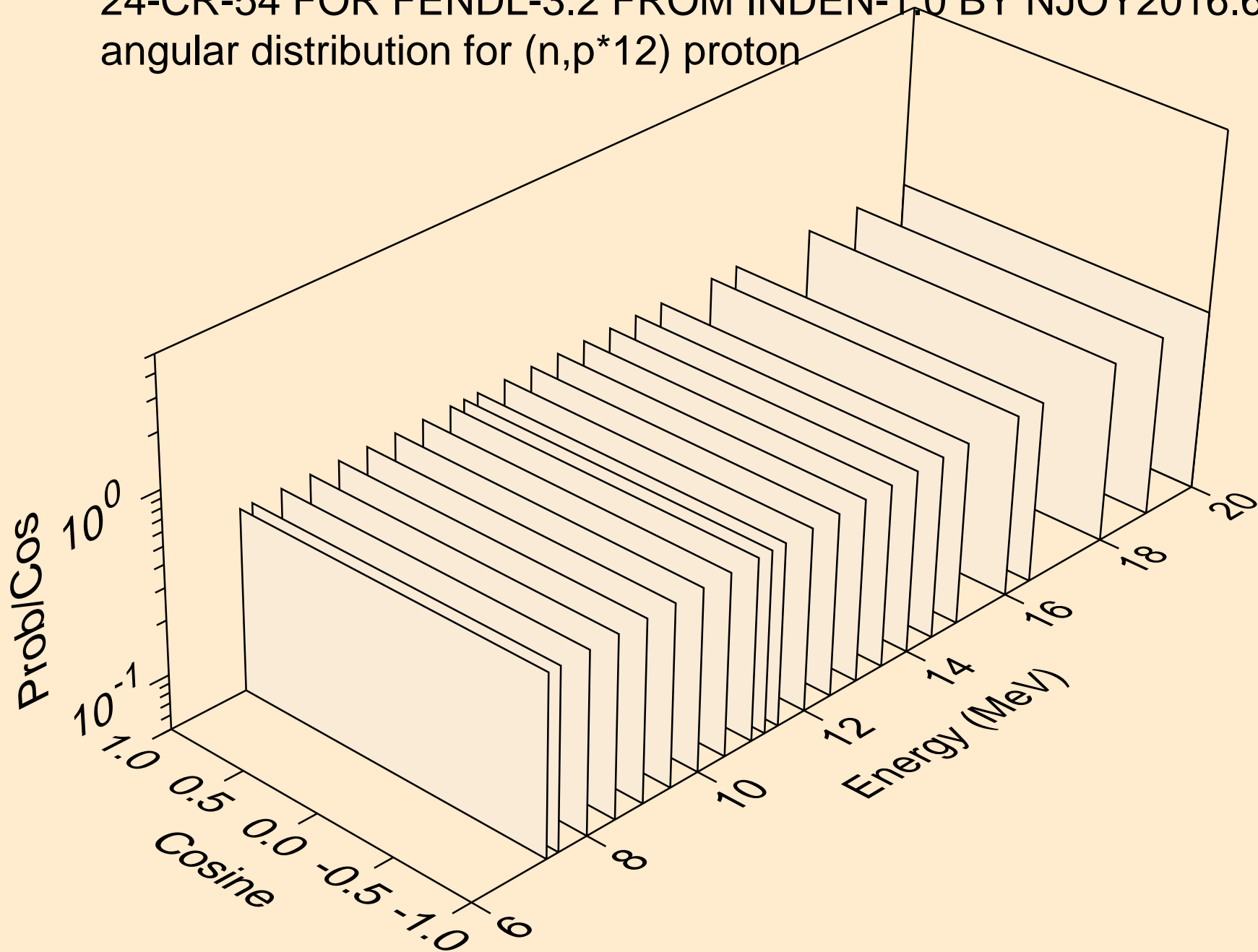

24-CR-54 FOR FENDL-3.2 FROM INDEN-1.0 BY NJOY2016.60+ OI
angular distribution for (n,p*12) proton

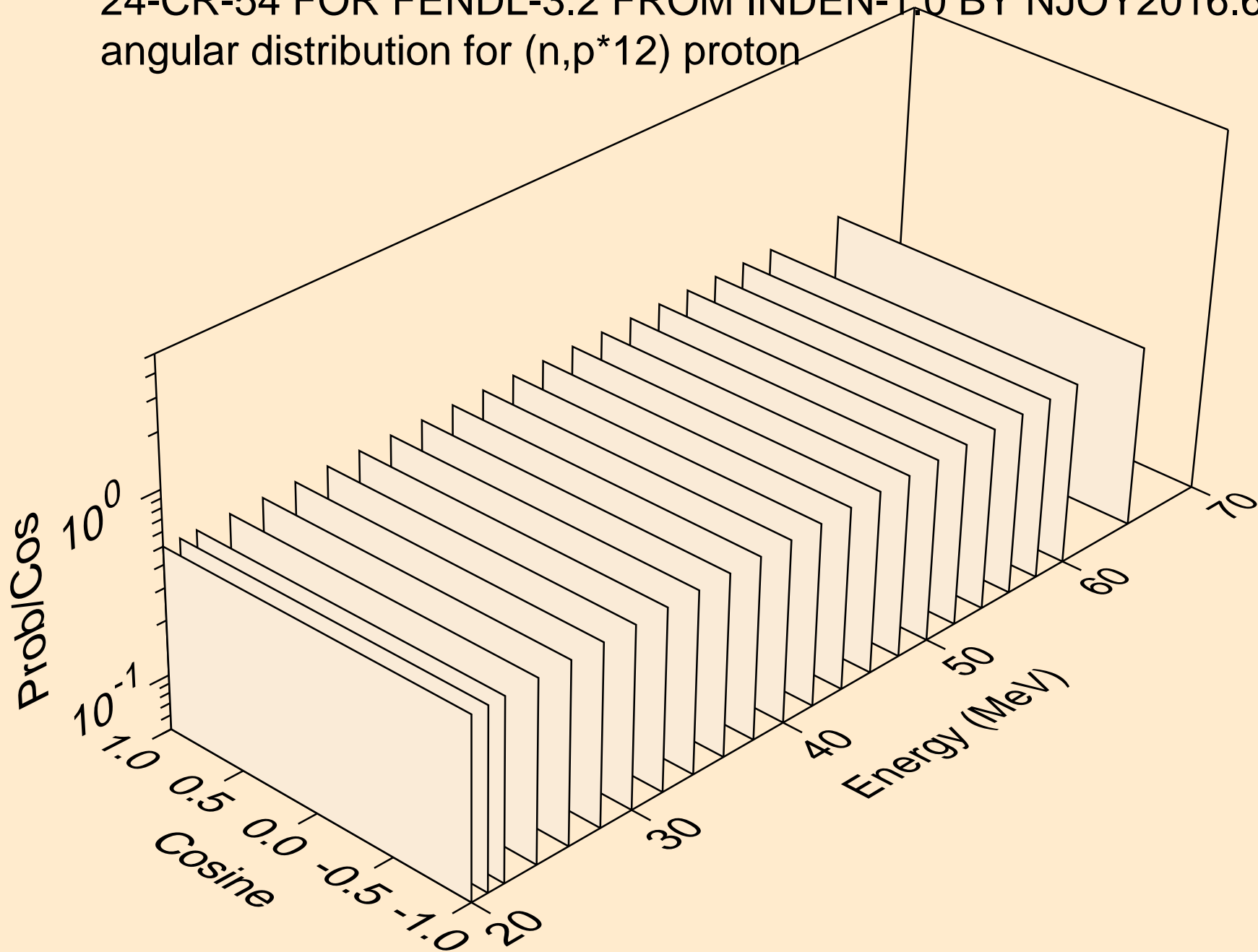

24-CR-54 FOR FENDL-3.2 FROM INDEN-1.0 BY NJOY2016.60+ OI
angular distribution for (n,p*13) proton

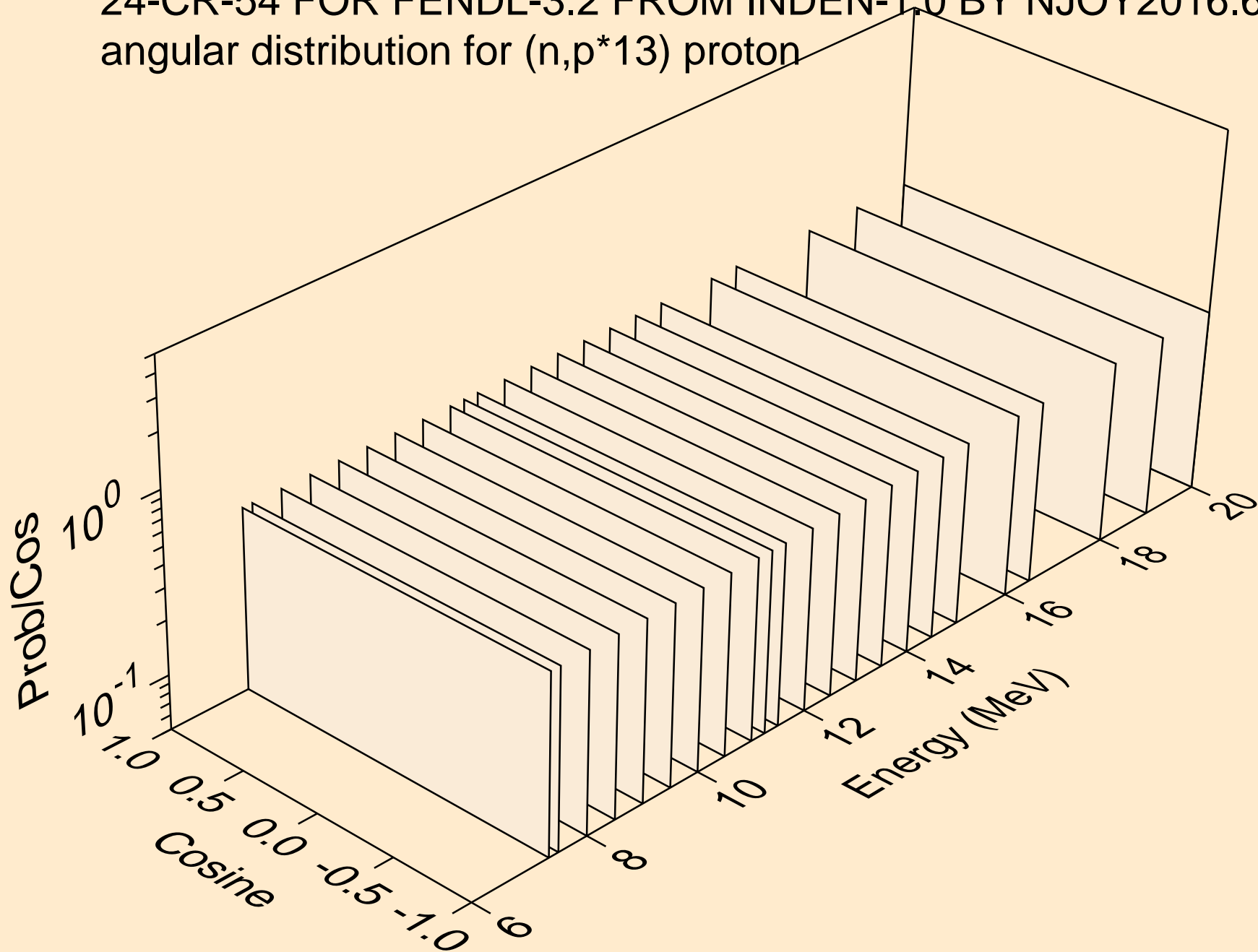

24-CR-54 FOR FENDL-3.2 FROM INDEN-1.0 BY NJOY2016.60+ OI
angular distribution for (n,p*13) proton

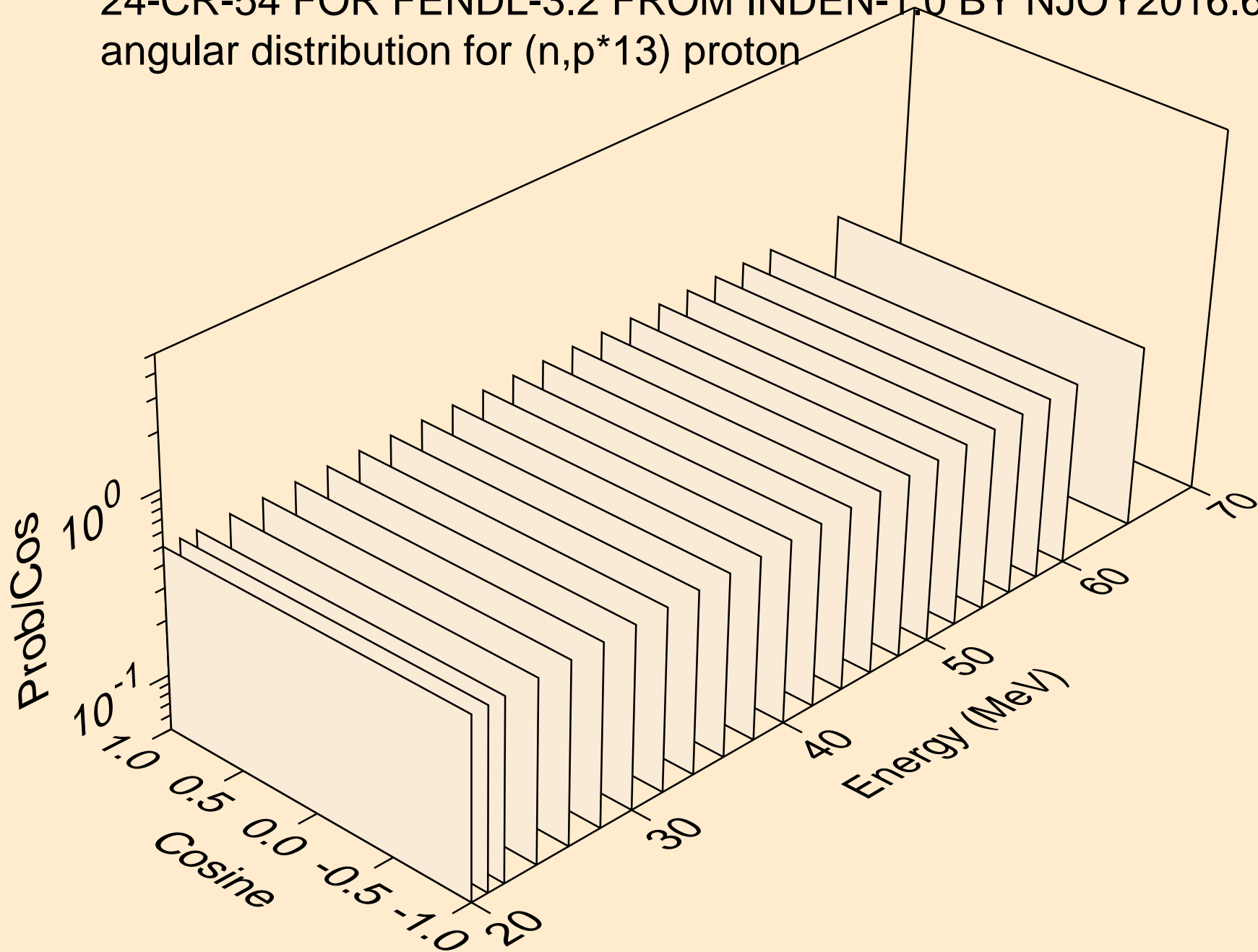

24-CR-54 FOR FENDL-3.2 FROM INDEN-1.0 BY NJOY2016.60+ OI
angular distribution for (n,p*14) proton

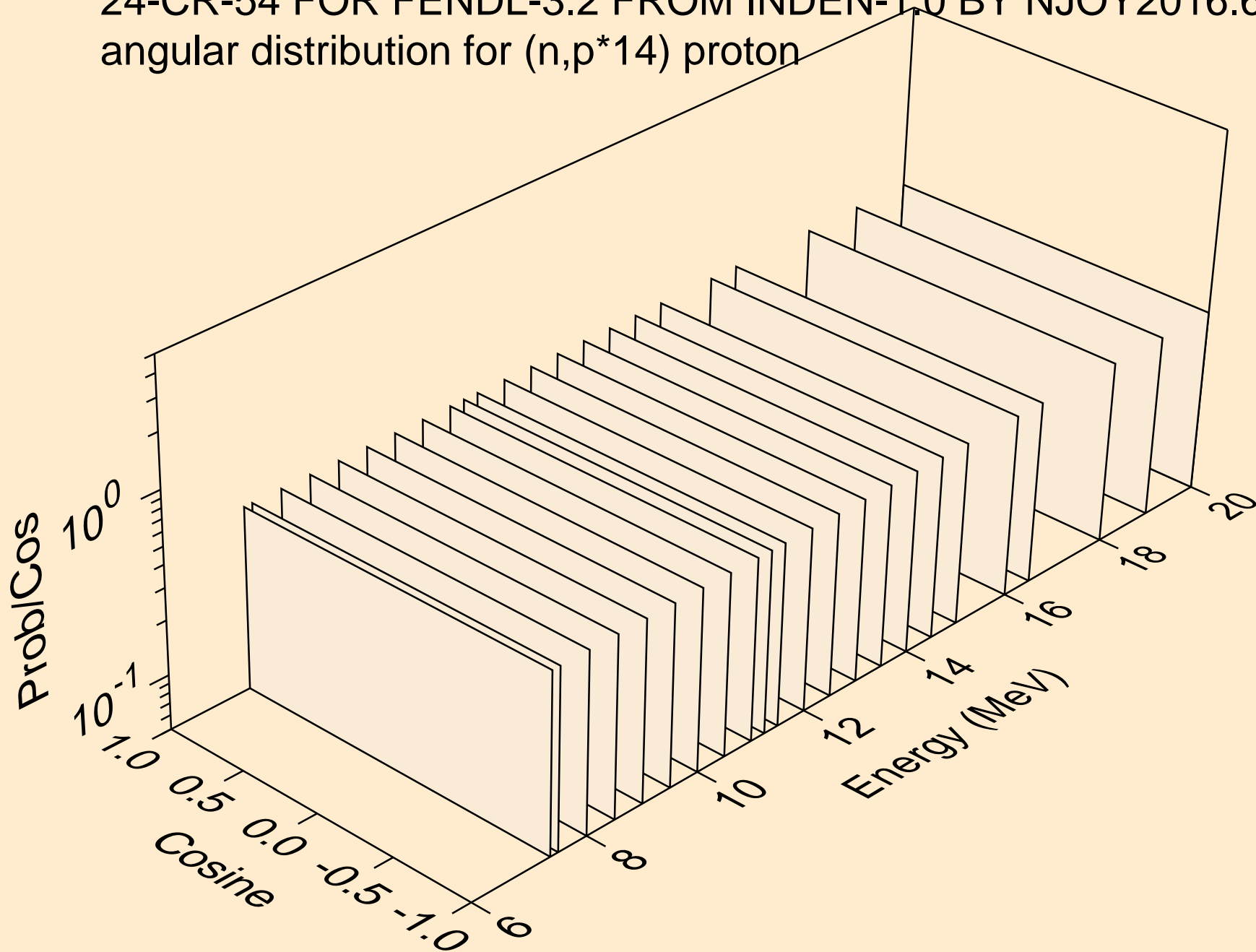

24-CR-54 FOR FENDL-3.2 FROM INDEN-1.0 BY NJOY2016.60+ OI
angular distribution for (n,p*14) proton

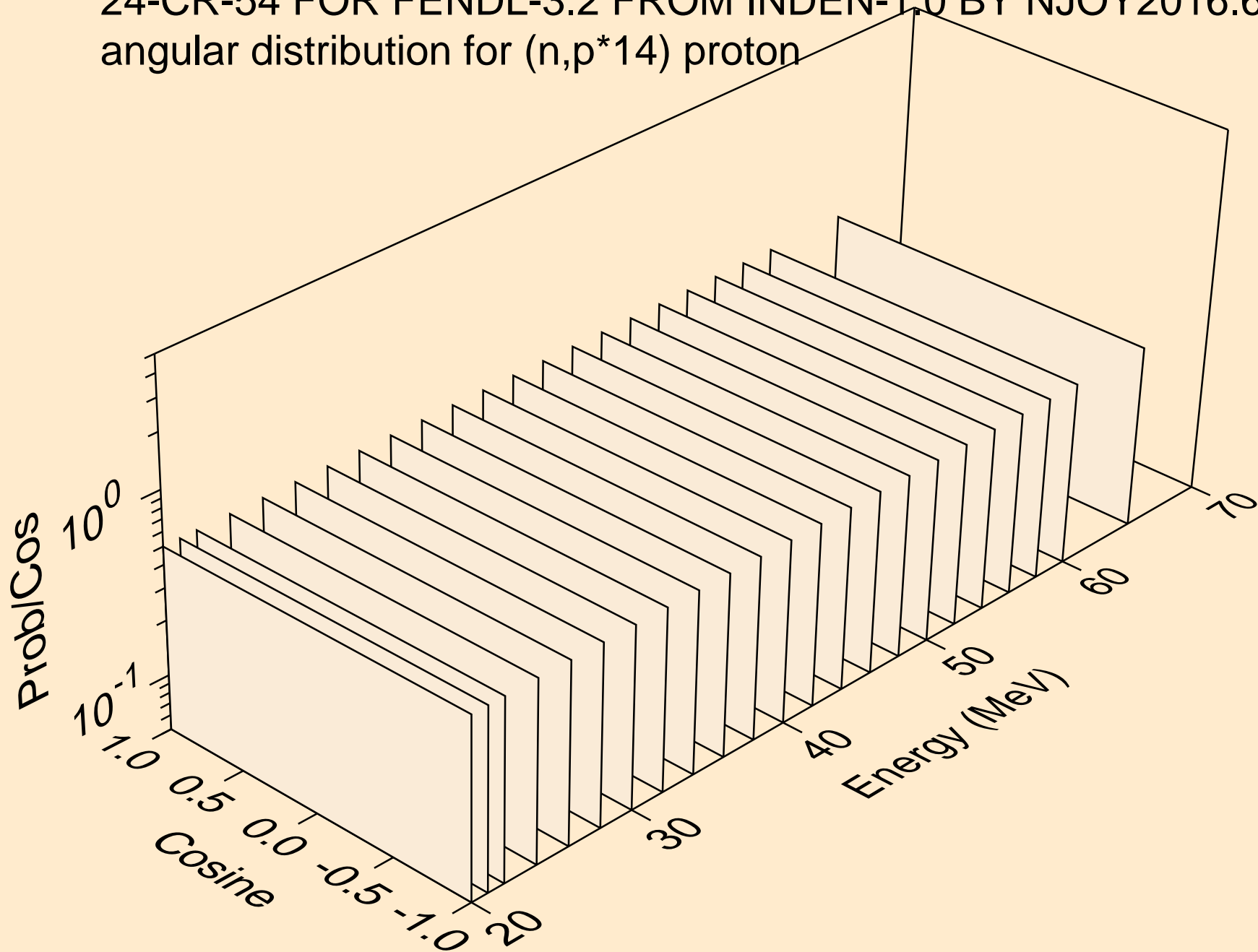

24-CR-54 FOR FENDL-3.2 FROM INDEN-1.0 BY NJOY2016.60+ OI
angular distribution for (n,p*15) proton

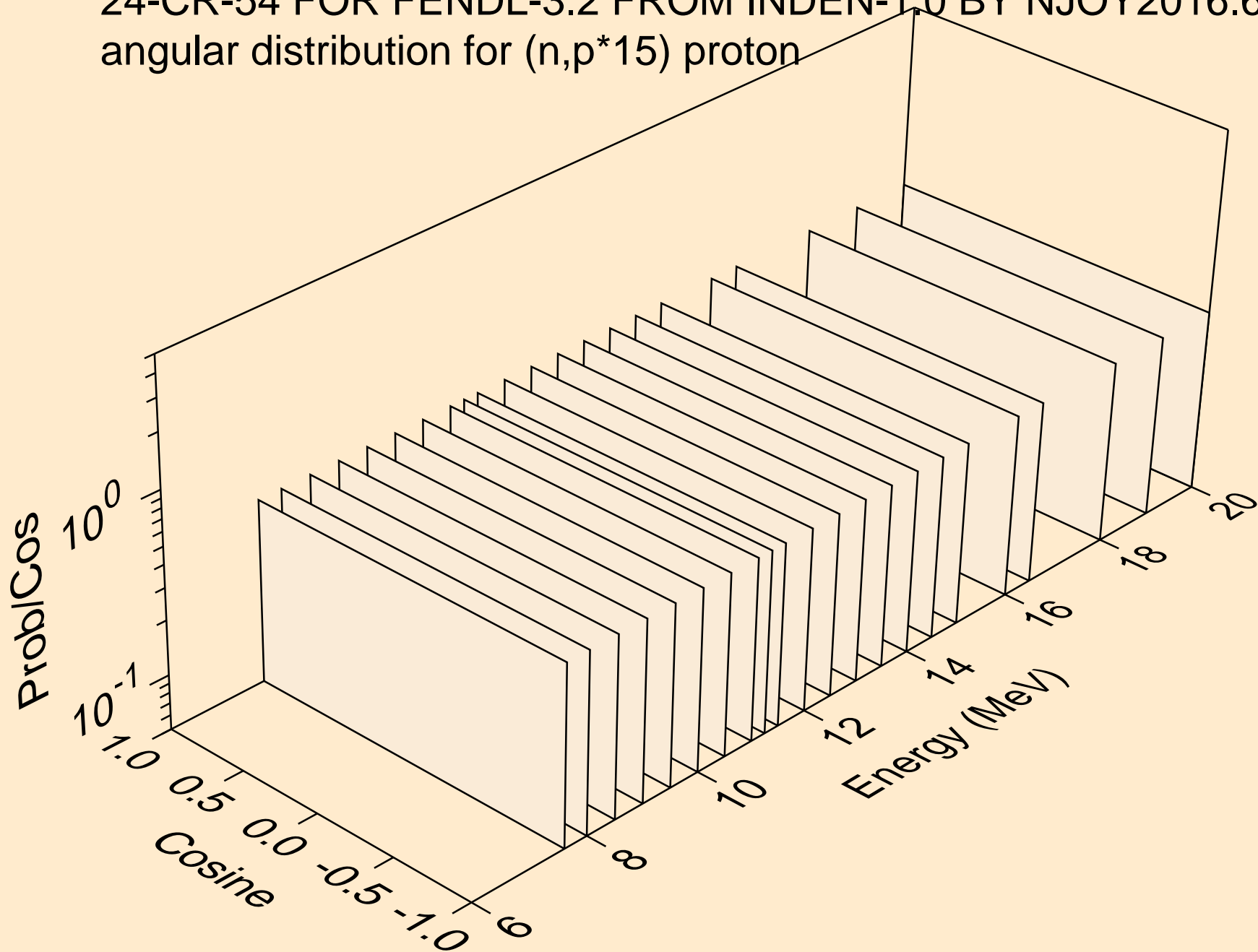

24-CR-54 FOR FENDL-3.2 FROM INDEN-1.0 BY NJOY2016.60+ OI
angular distribution for (n,p*15) proton

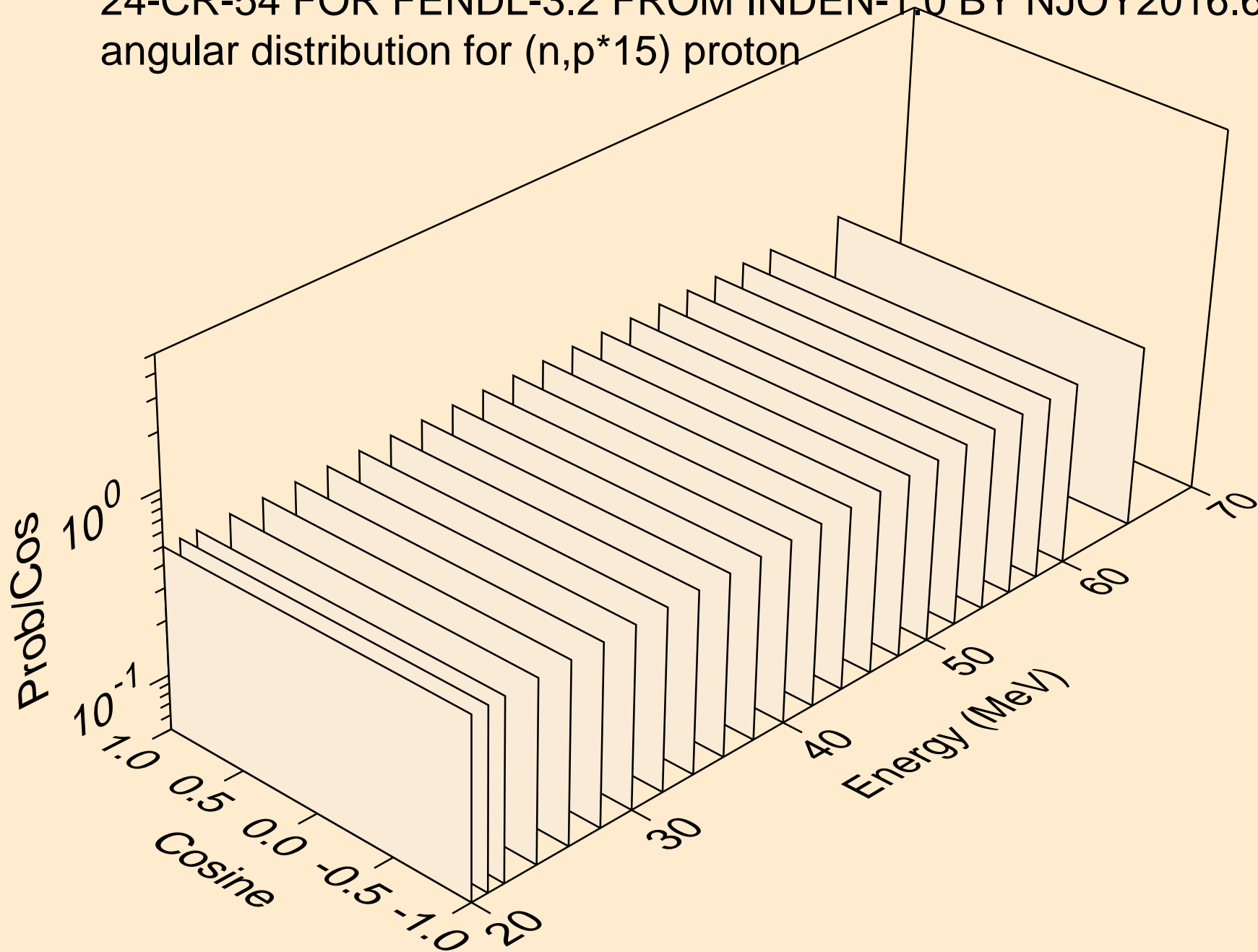

24-CR-54 FOR FENDL-3.2 FROM INDEN-1.0 BY NJOY2016.60+ OI
angular distribution for (n,p*16) proton

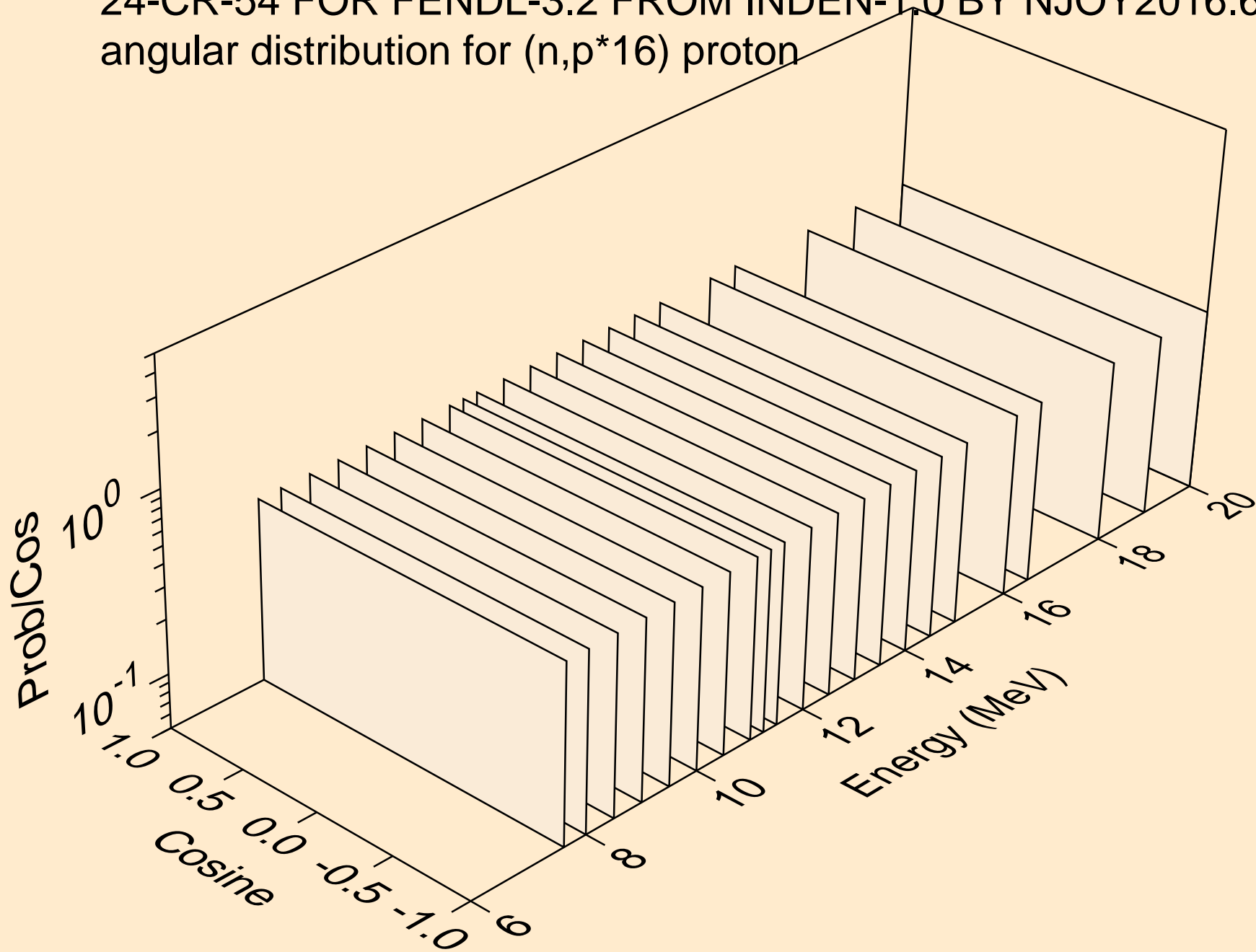

24-CR-54 FOR FENDL-3.2 FROM INDEN-1.0 BY NJOY2016.60+ OI
angular distribution for (n,p*16) proton

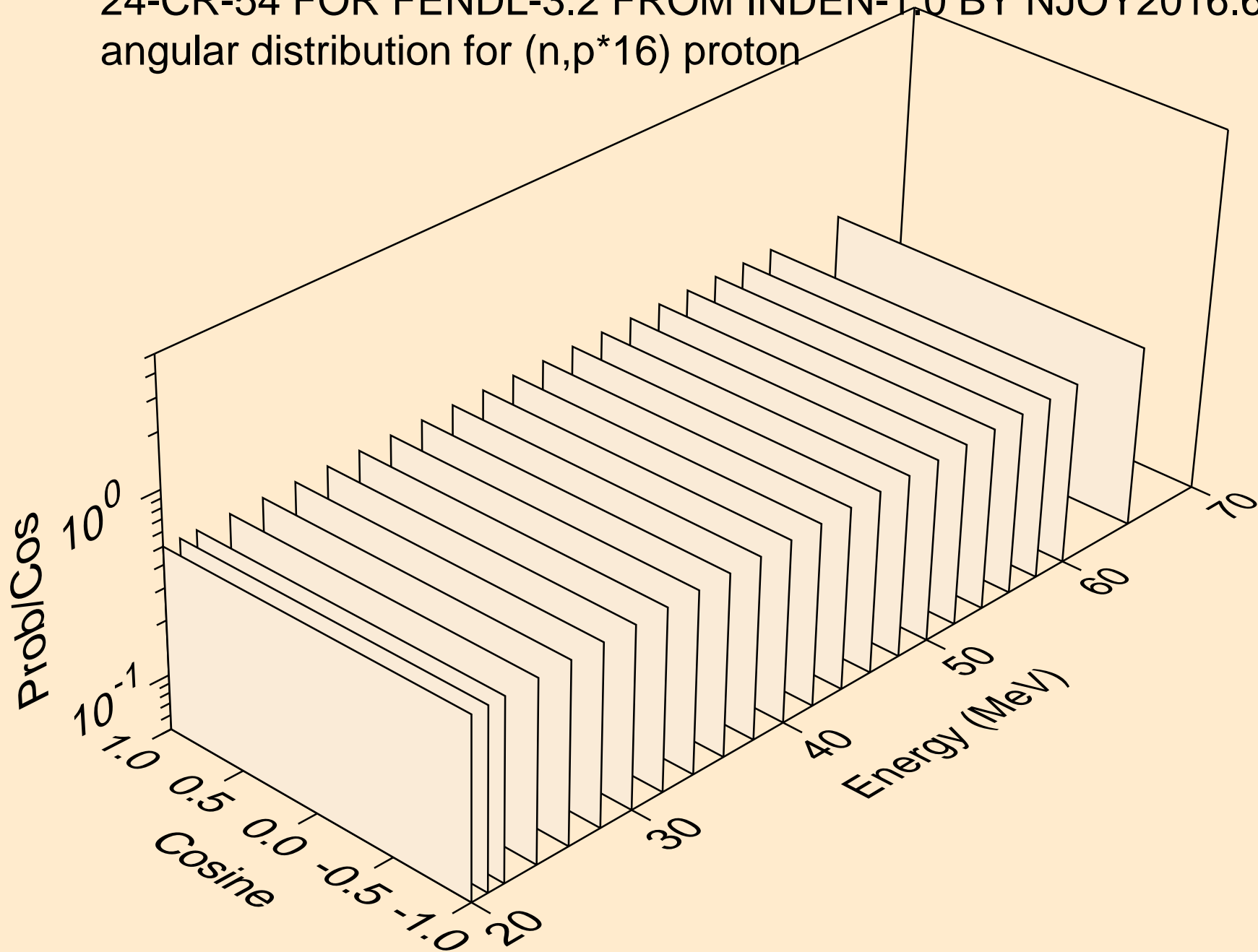

24-CR-54 FOR FENDL-3.2 FROM INDEN-1.0 BY NJOY2016.60+ OI
protons from (n,p*c)

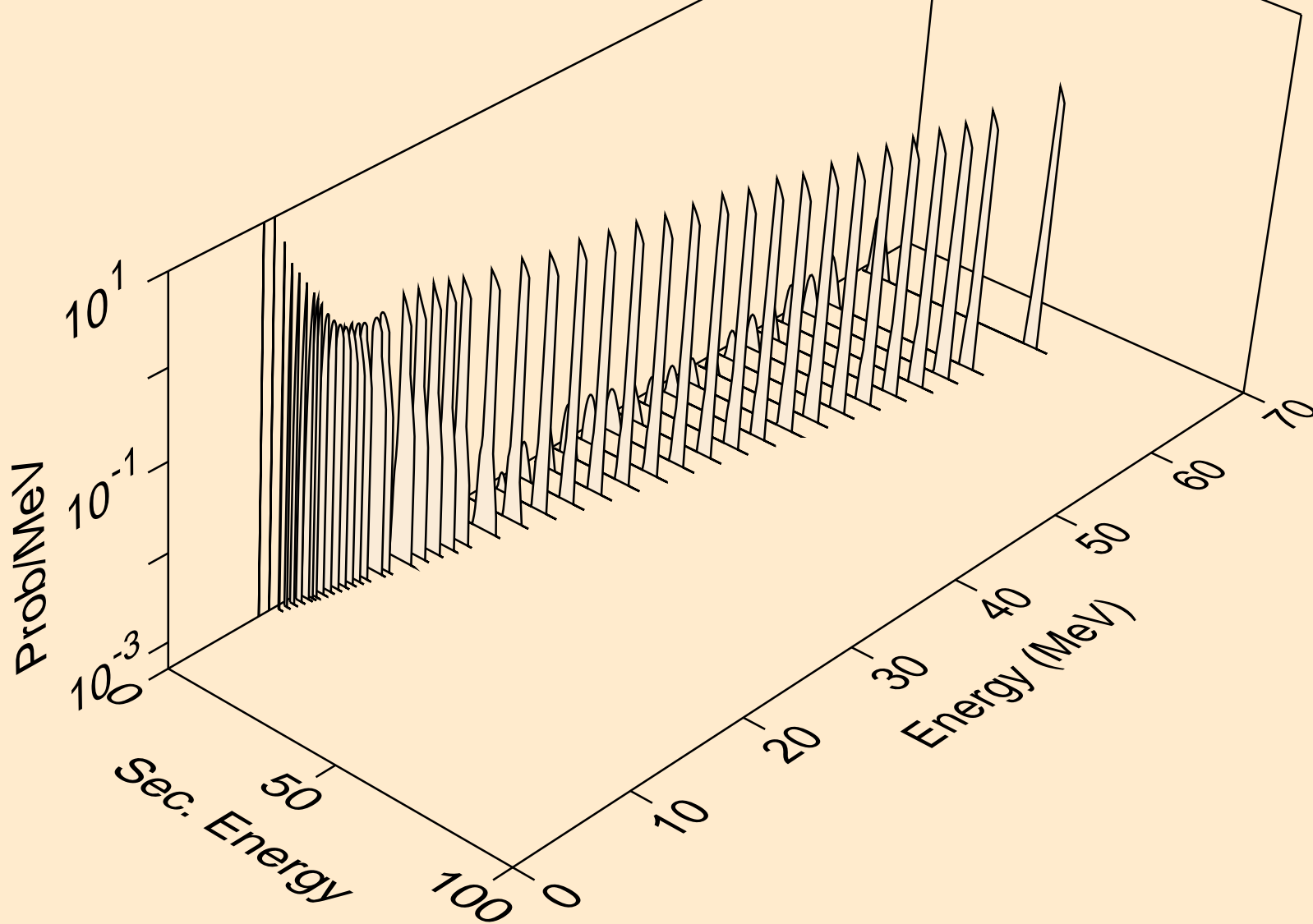

24-CR-54 FOR FENDL-3.2 FROM INDEN-1.0 BY NJOY2016.60+ OI
deuterons from (n,x)

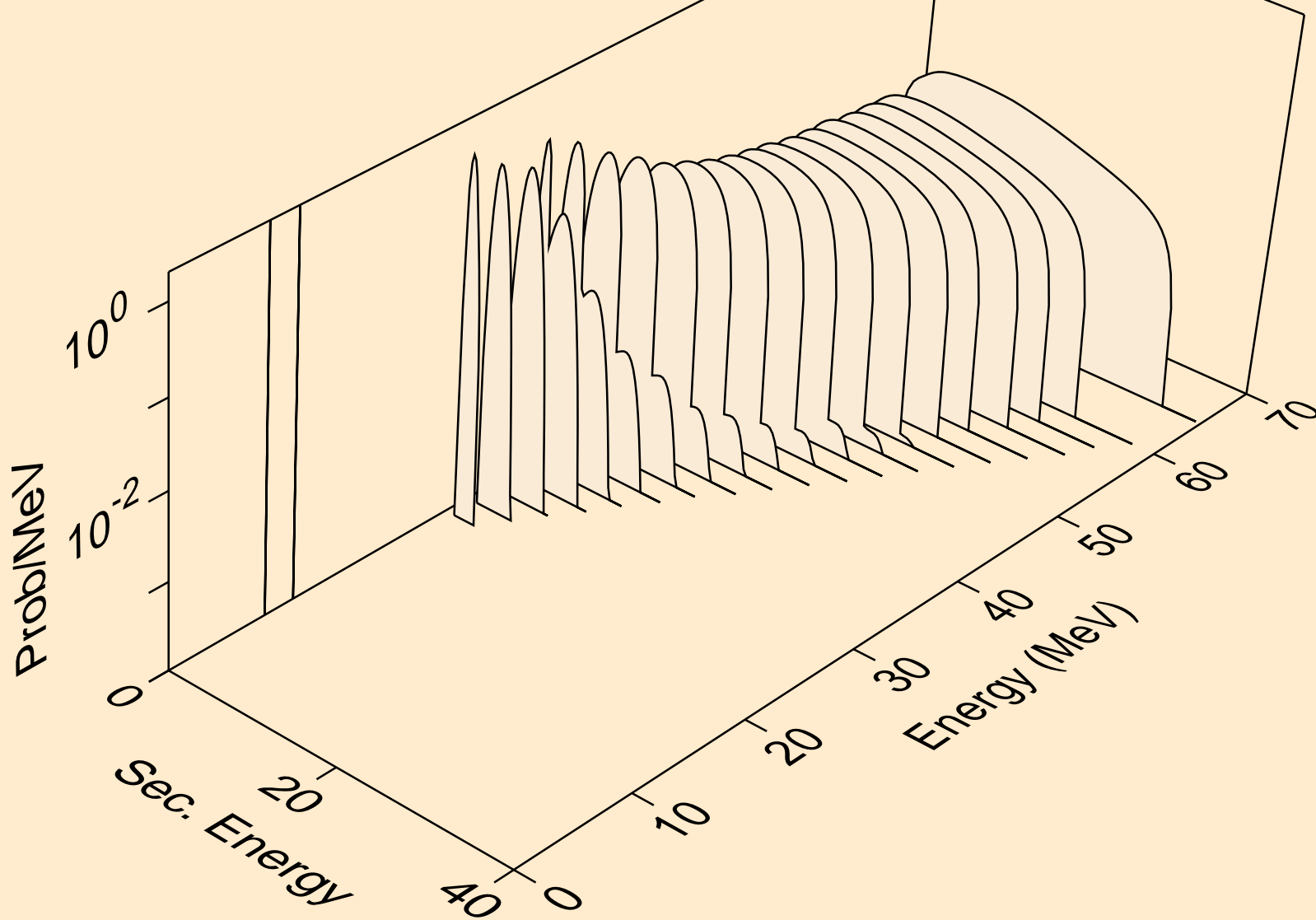

24-CR-54 FOR FENDL-3.2 FROM INDEN-1.0 BY NJOY2016.60+ OI
deuterons from (n,n*)d

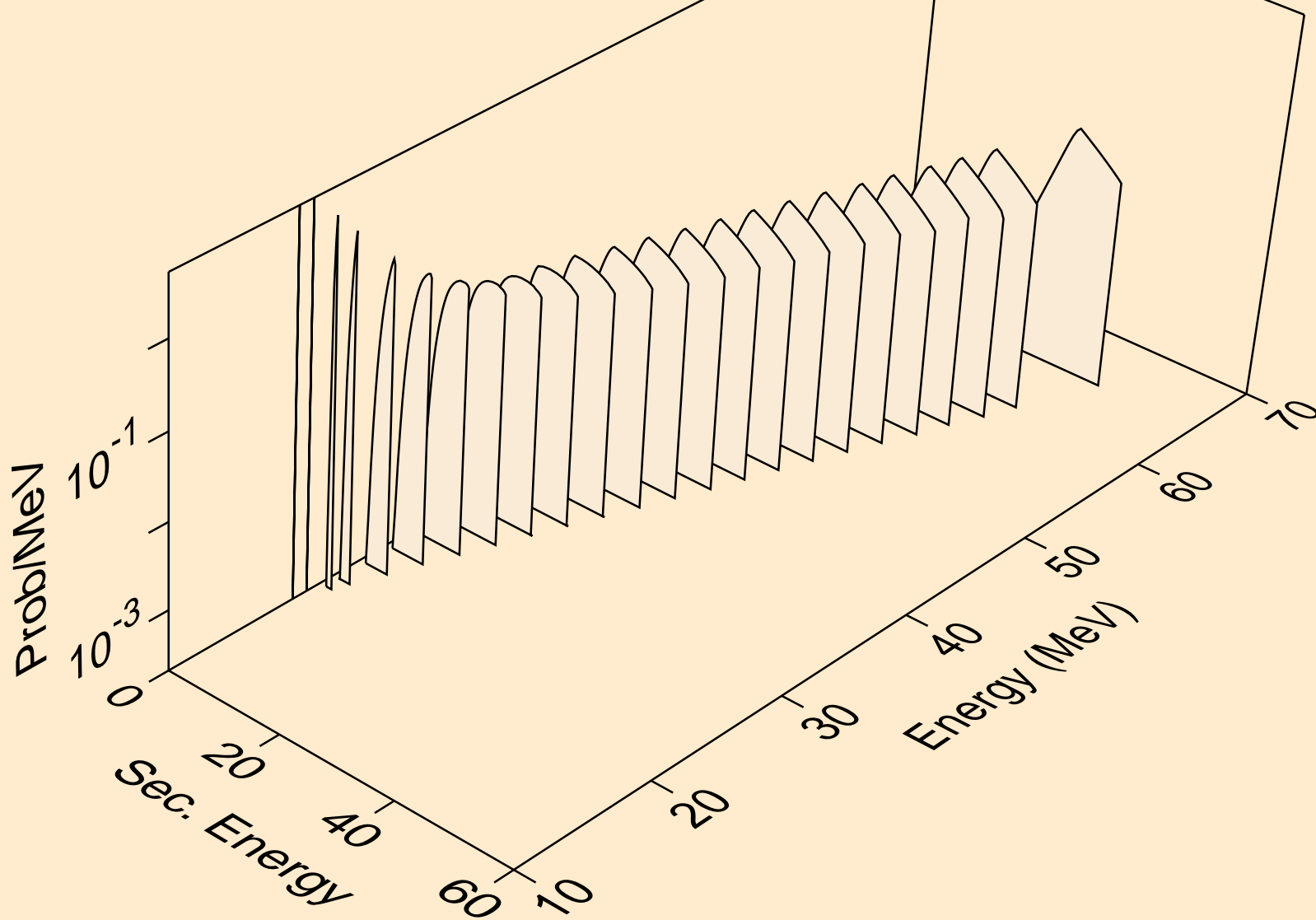

24-CR-54 FOR FENDL-3.2 FROM INDEN-1.0 BY NJOY2016.60+ OI
deuterons from (n,d)

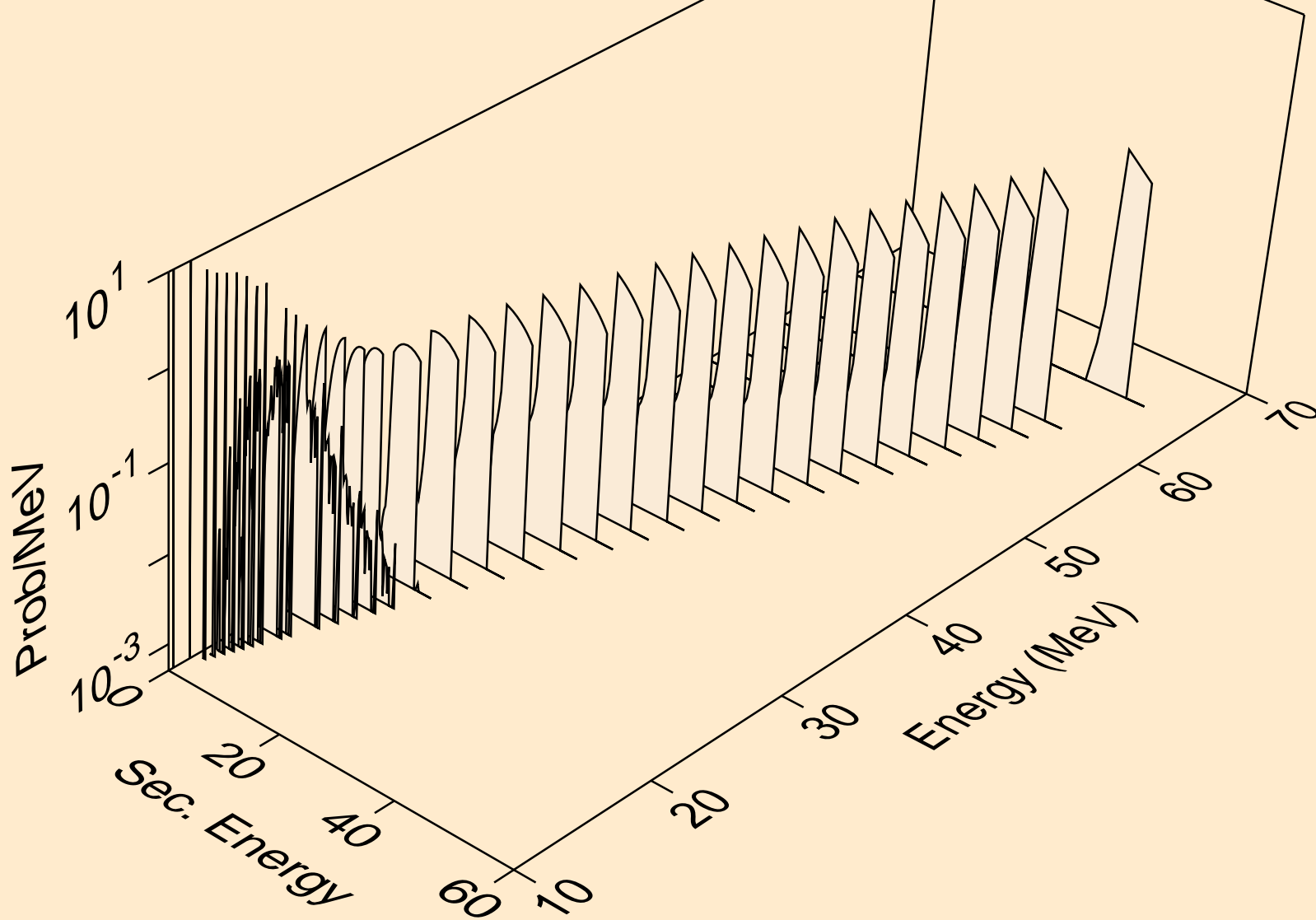

24-CR-54 FOR FENDL-3.2 FROM INDEN-1.0 BY NJOY2016.60+ OI
deuterons from (n,pd)

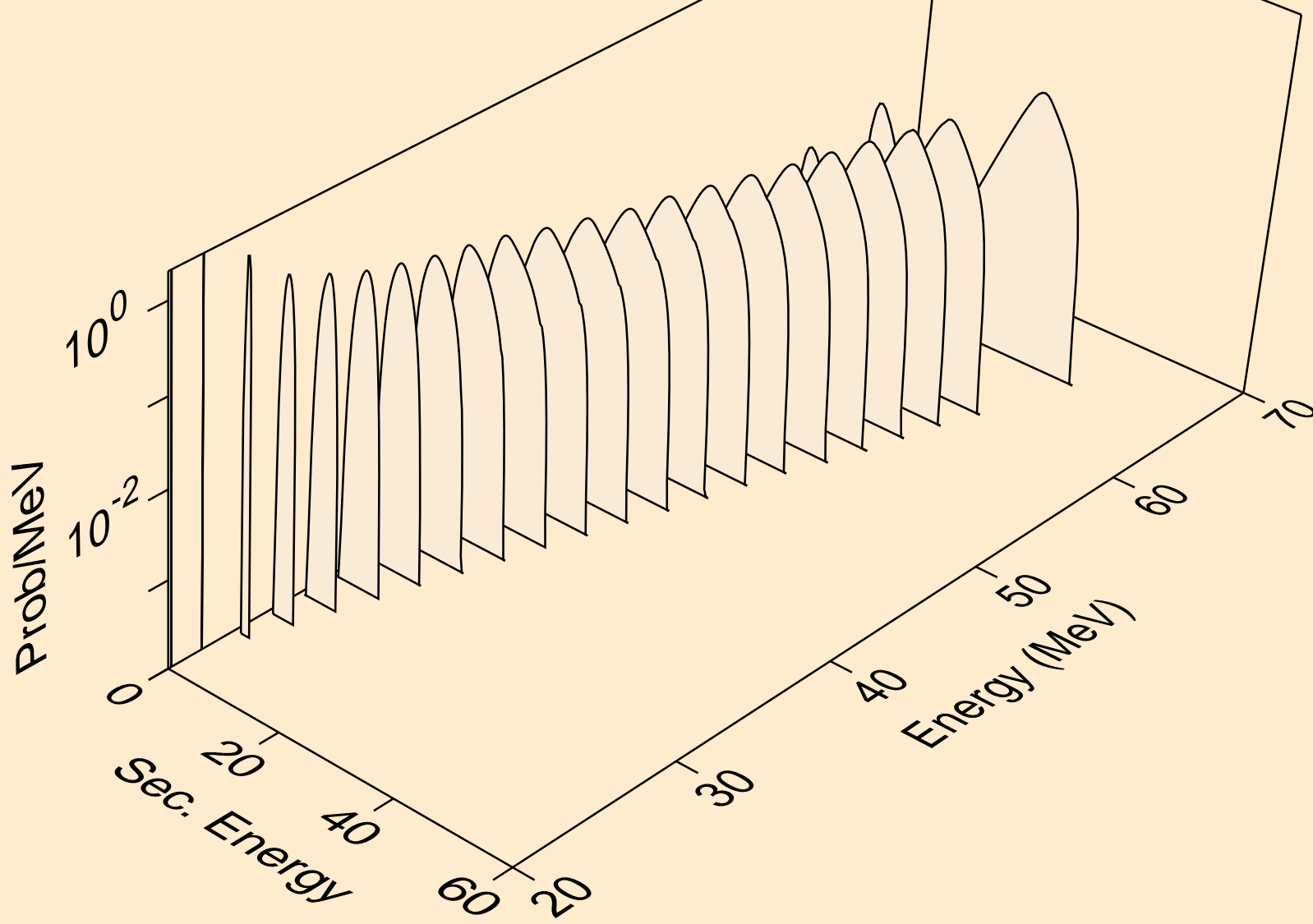

24-CR-54 FOR FENDL-3.2 FROM INDEN-1.0 BY NJOY2016.60+ OI
tritons from (n,x)

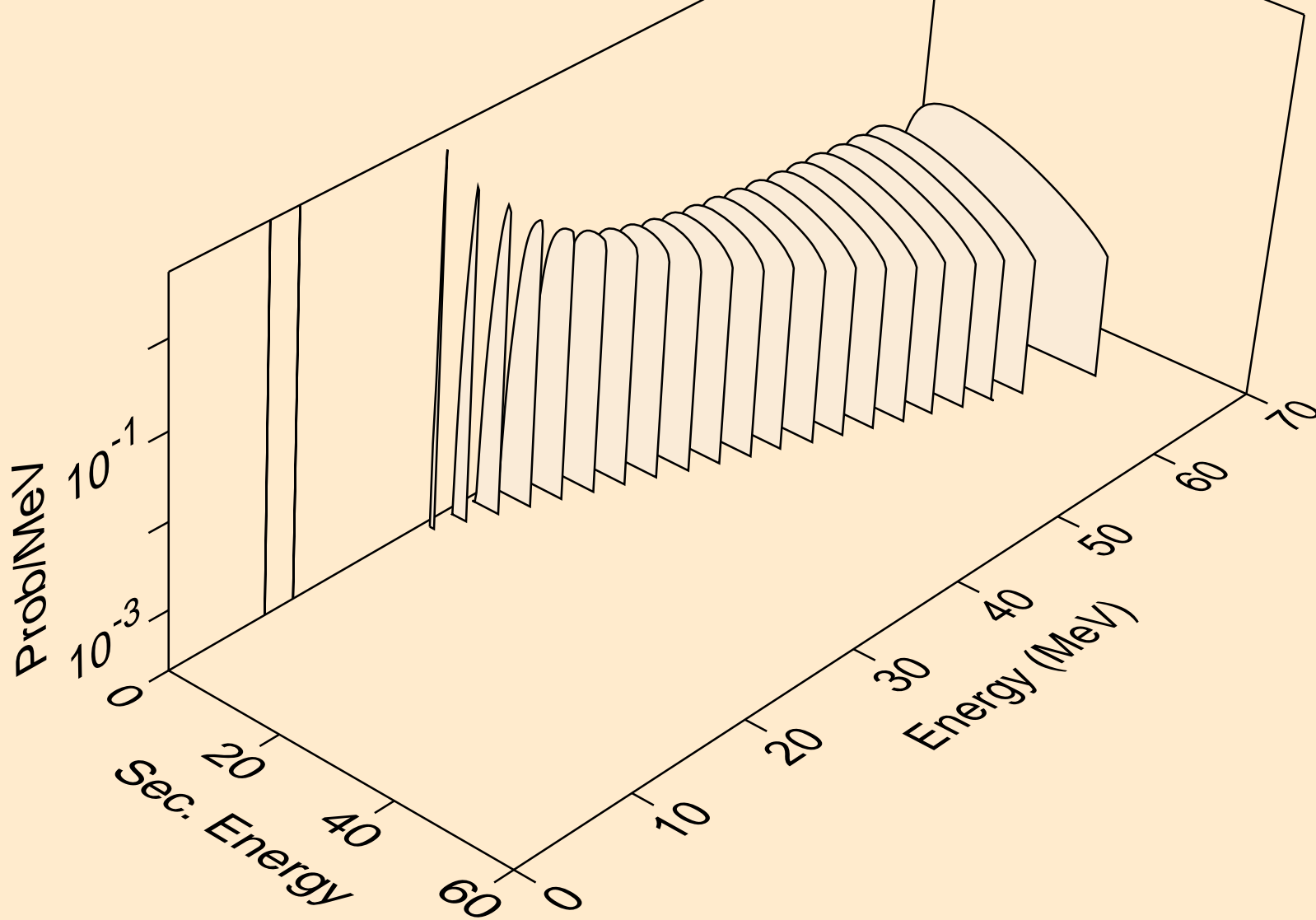

24-CR-54 FOR FENDL-3.2 FROM INDEN-1.0 BY NJOY2016.60+ OI
tritons from (n,t)

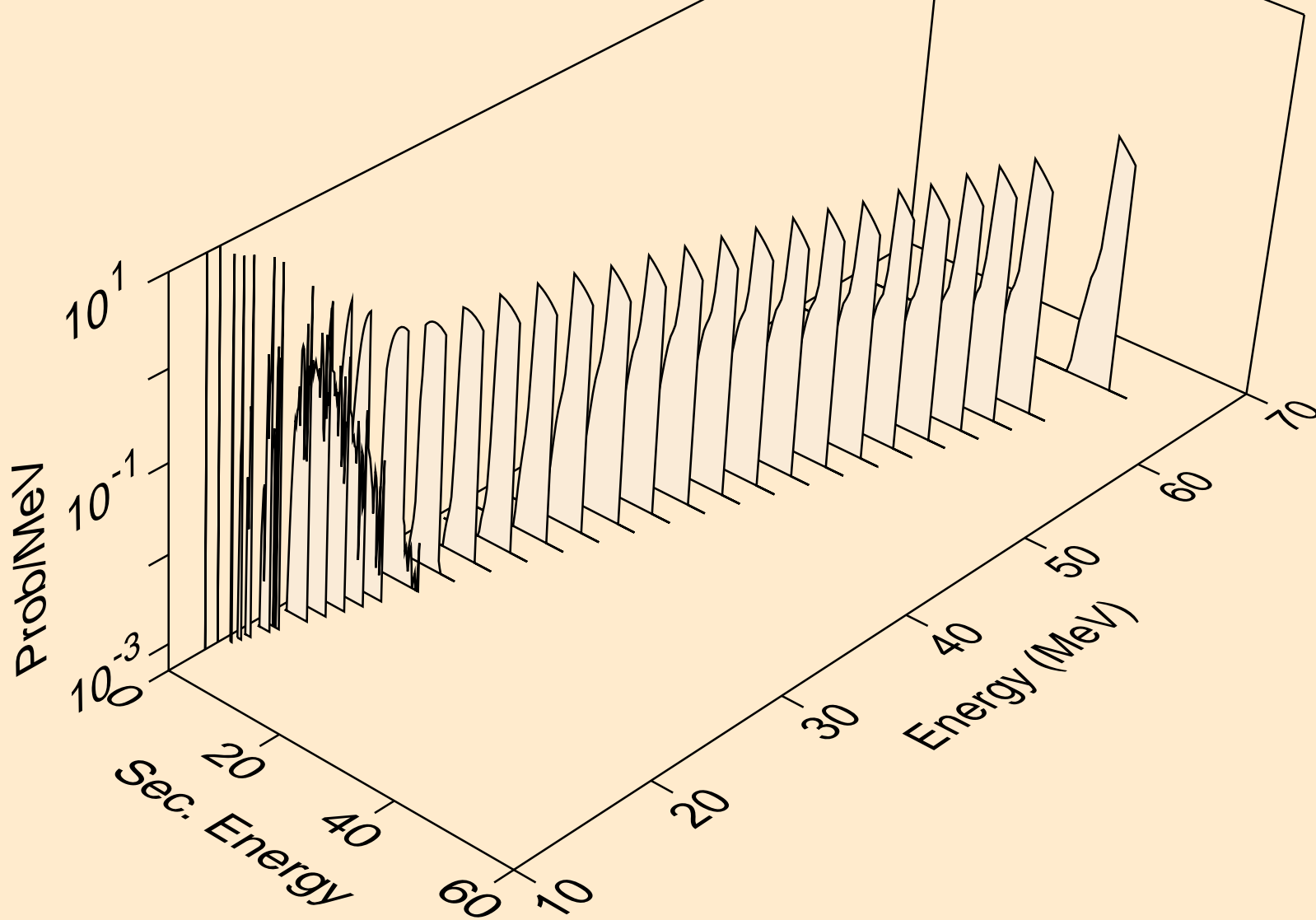

24-CR-54 FOR FENDL-3.2 FROM INDEN-1.0 BY NJOY2016.60+ OI
tritons from (n,pt)

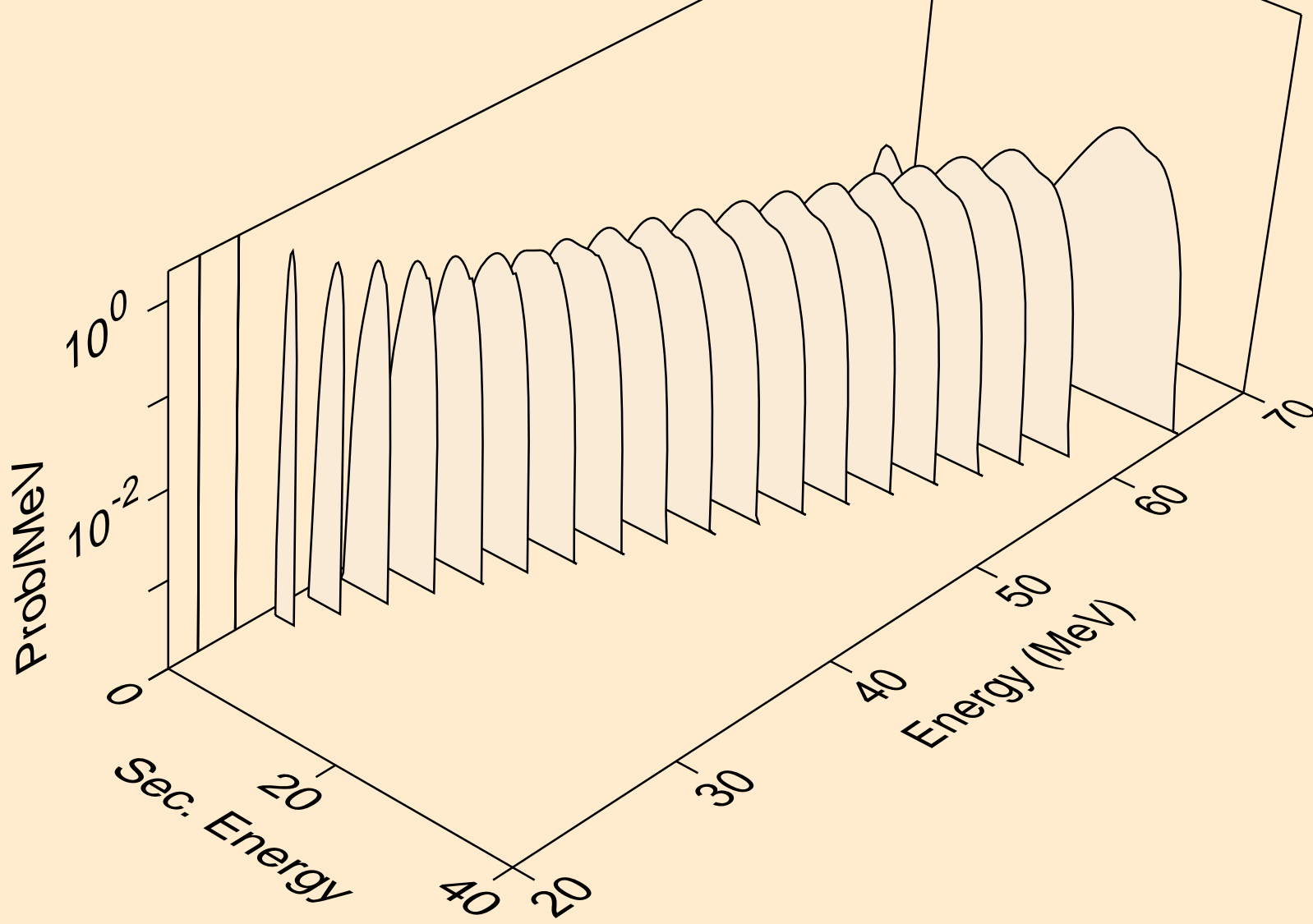

24-CR-54 FOR FENDL-3.2 FROM INDEN-1.0 BY NJOY2016.60+ OI
he3s from (n,x)

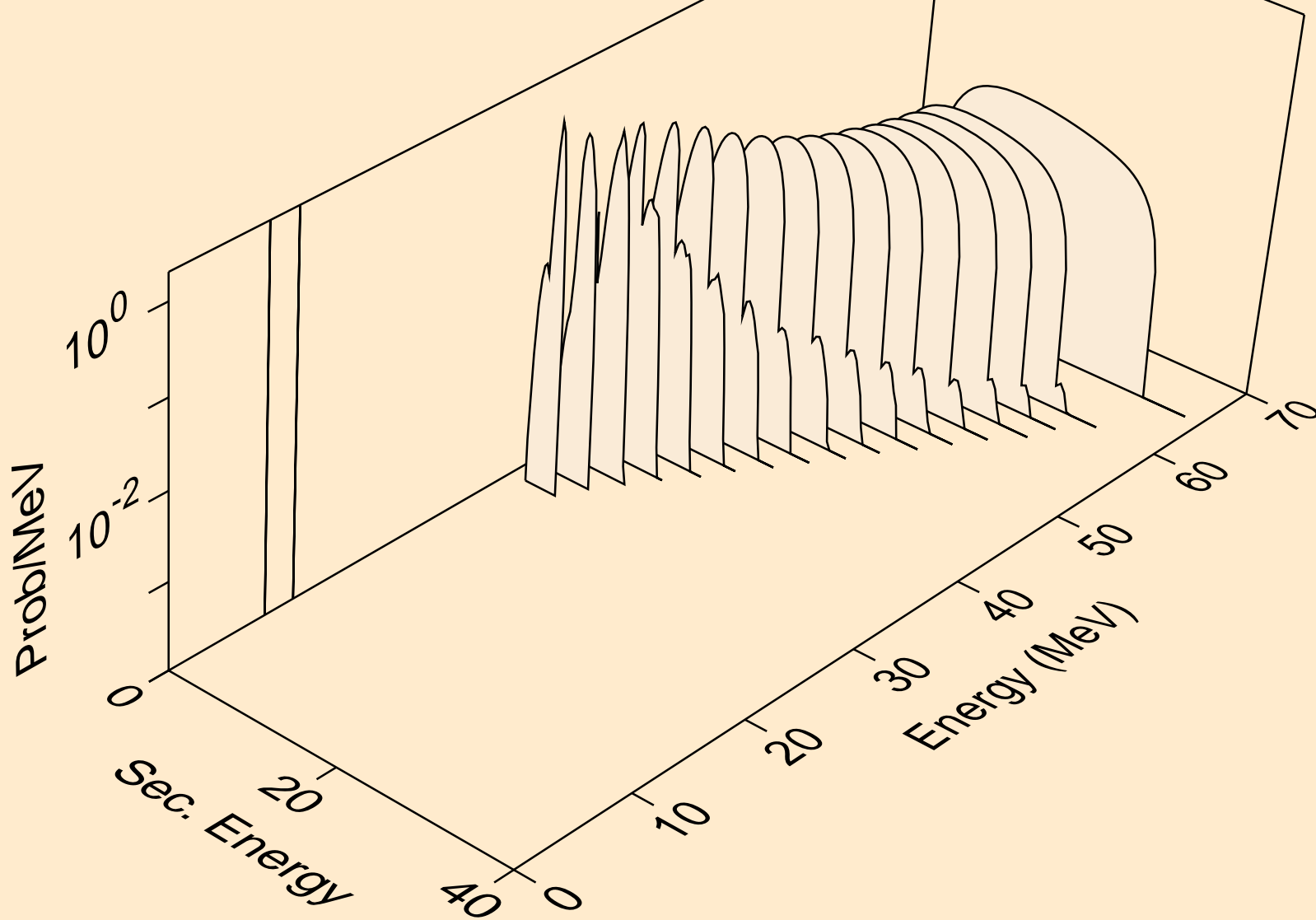

24-CR-54 FOR FENDL-3.2 FROM INDEN-1.0 BY NJOY2016.60+ OI
he3s from (n,n*)he3

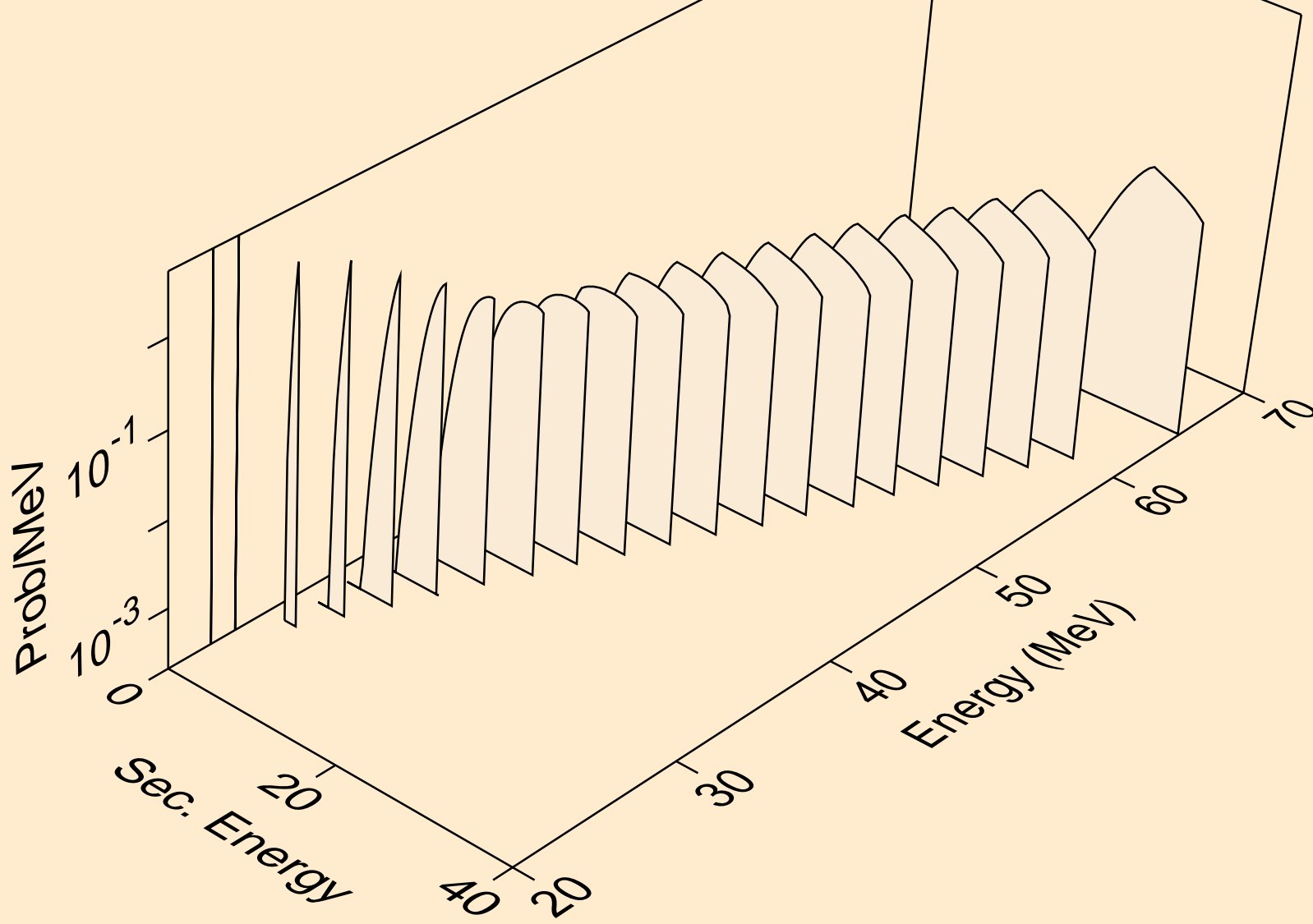

24-CR-54 FOR FENDL-3.2 FROM INDEN-1.0 BY NJOY2016.60+ OI
he3s from (n,he3)

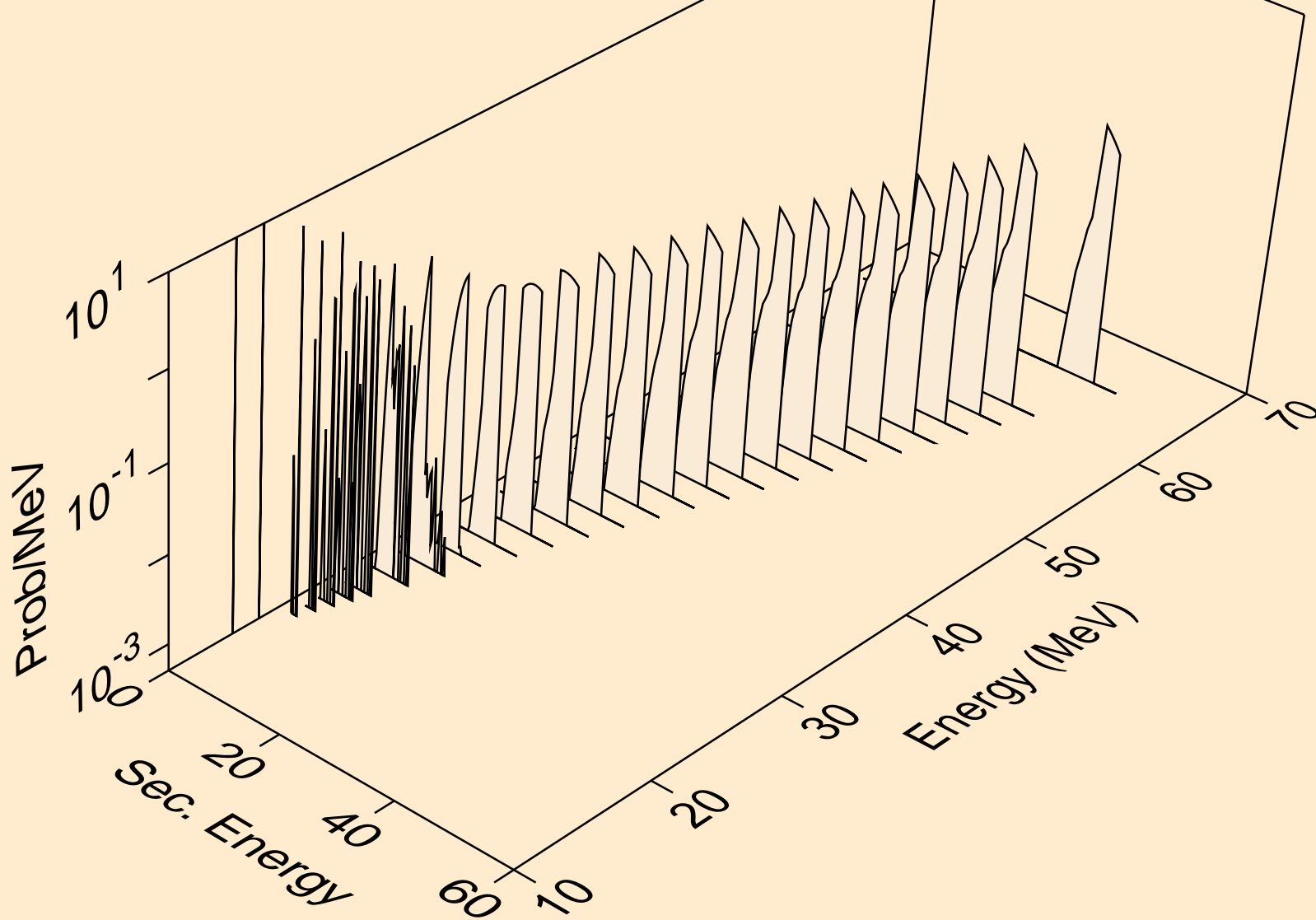

24-CR-54 FOR FENDL-3.2 FROM INDEN-1.0 BY NJOY2016.60+ OI
alphas from (n,x)

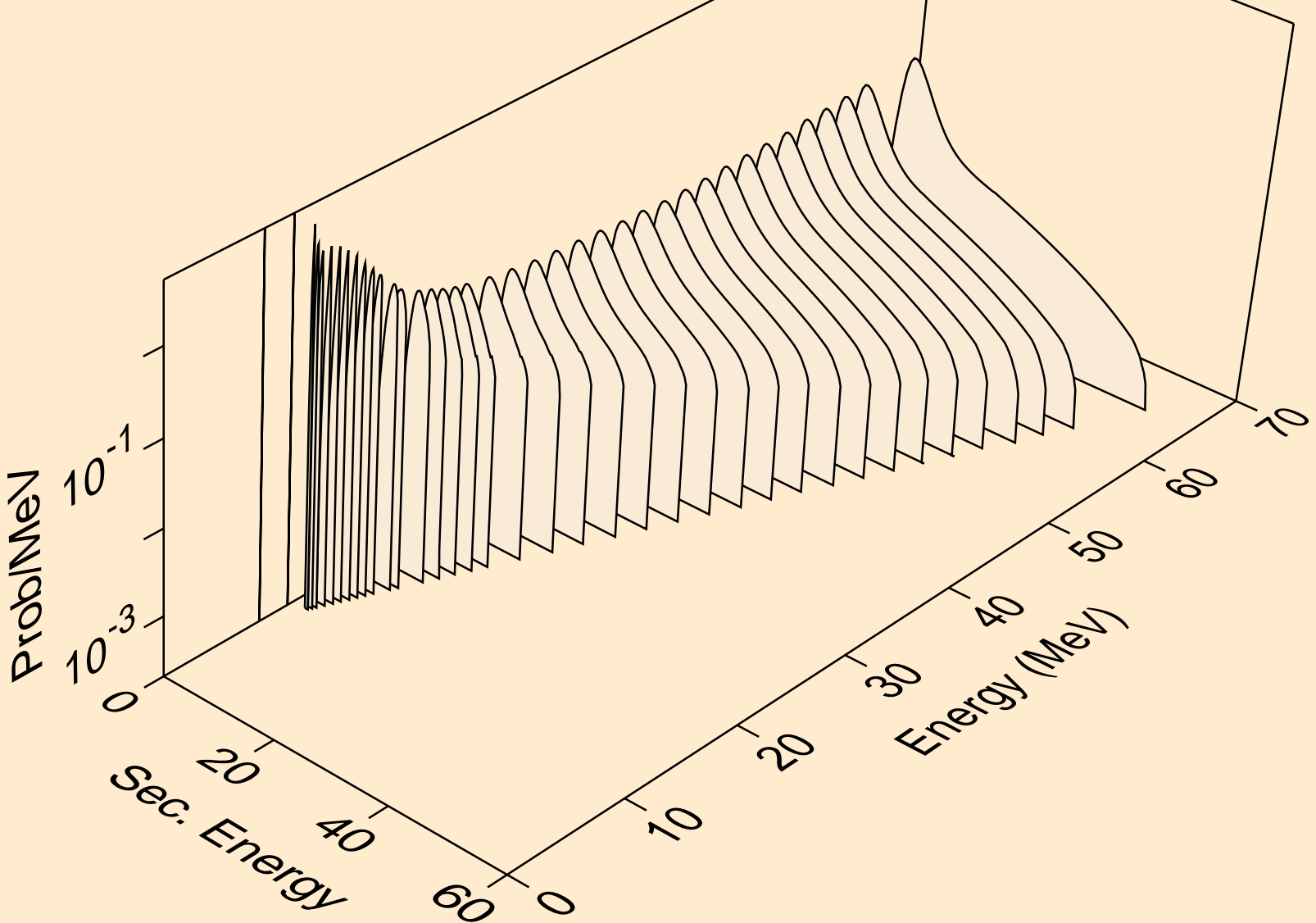

24-CR-54 FOR FENDL-3.2 FROM INDEN-1.0 BY NJOY2016.60+ OI
angular distribution for (n,a*0) alpha

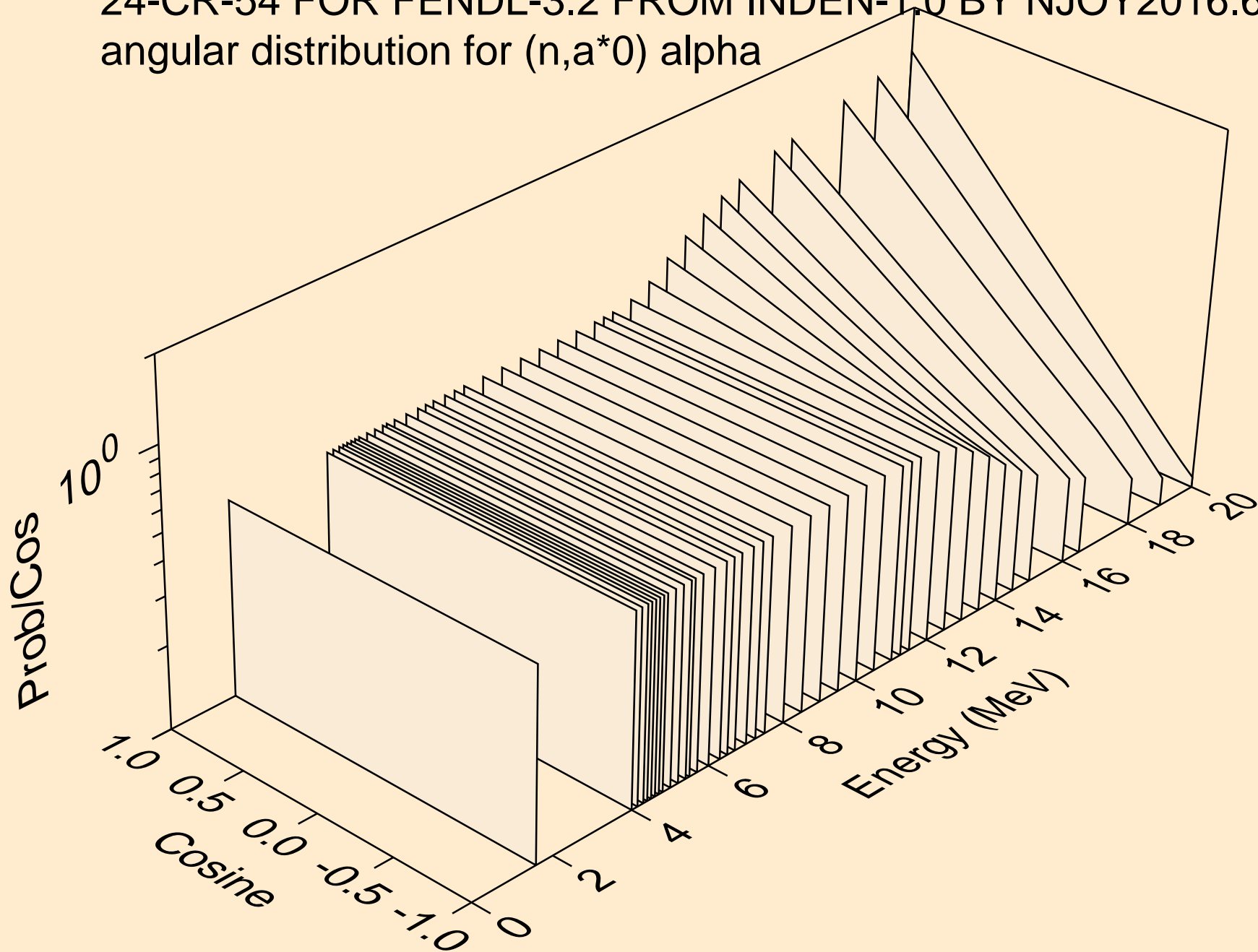

24-CR-54 FOR FENDL-3.2 FROM INDEN-1.0 BY NJOY2016.60+ OI
angular distribution for (n,a*0) alpha

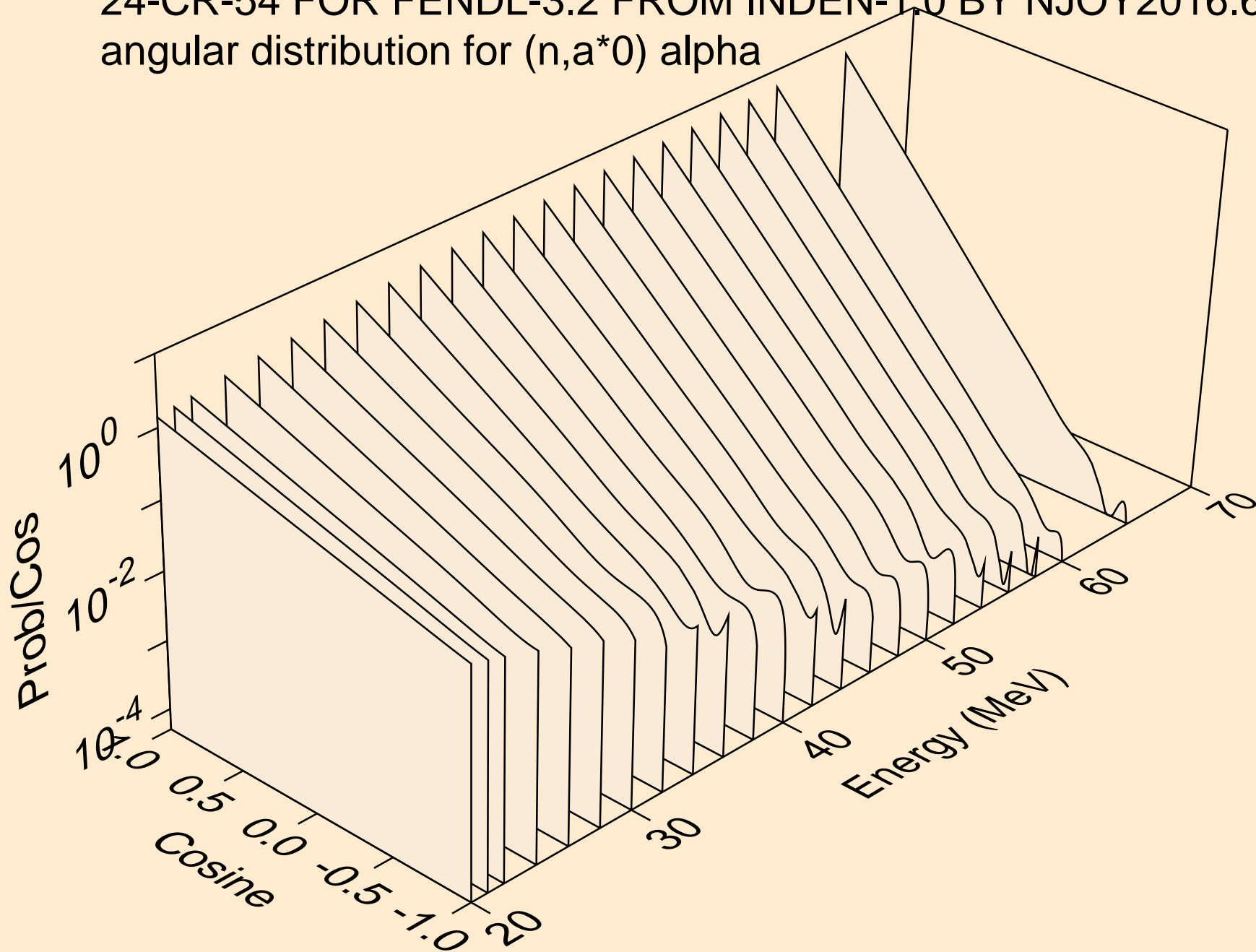

24-CR-54 FOR FENDL-3.2 FROM INDEN-1.0 BY NJOY2016.60+ OI
angular distribution for (n,a*1) alpha

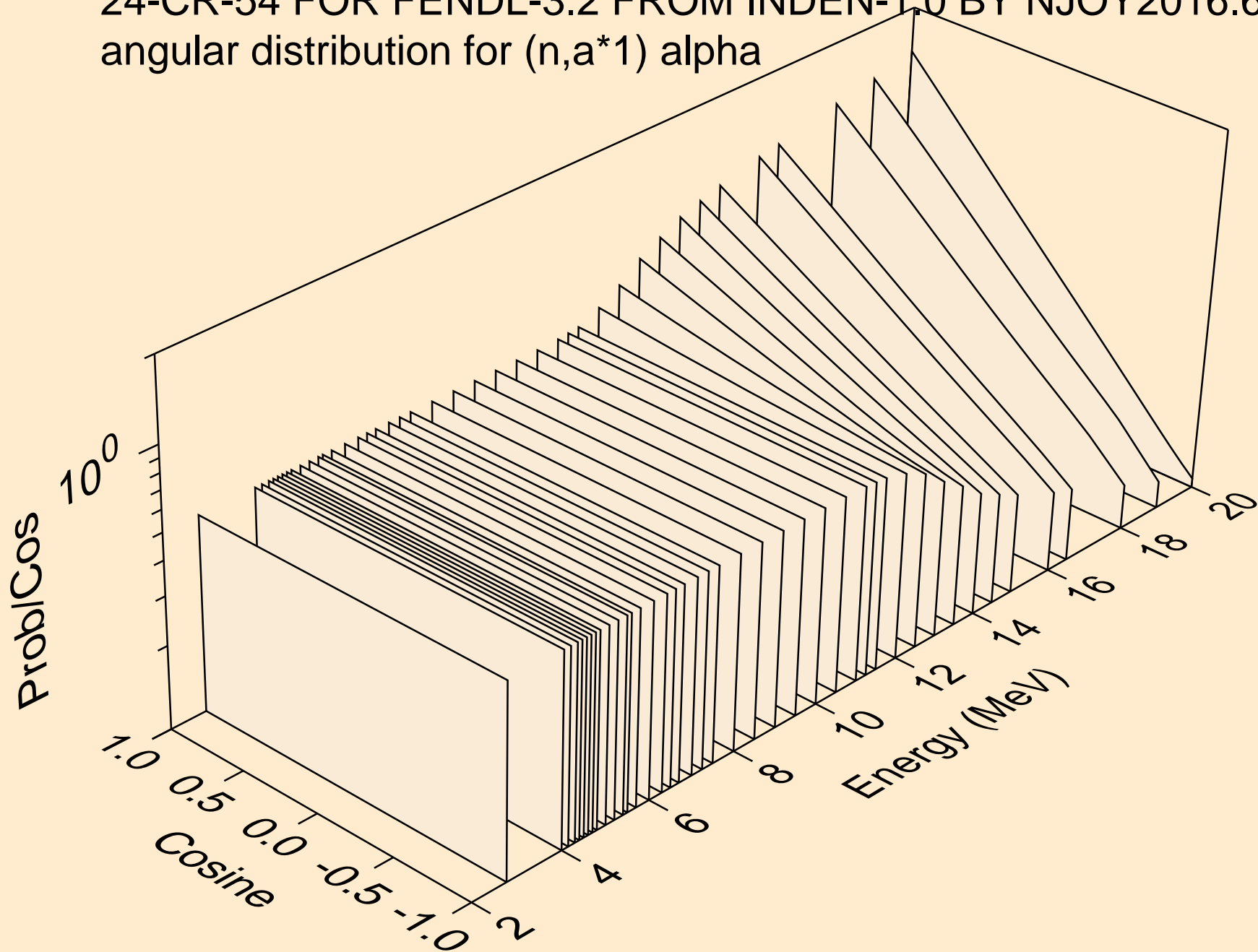

24-CR-54 FOR FENDL-3.2 FROM INDEN-1.0 BY NJOY2016.60+ OI
angular distribution for (n,a*1) alpha

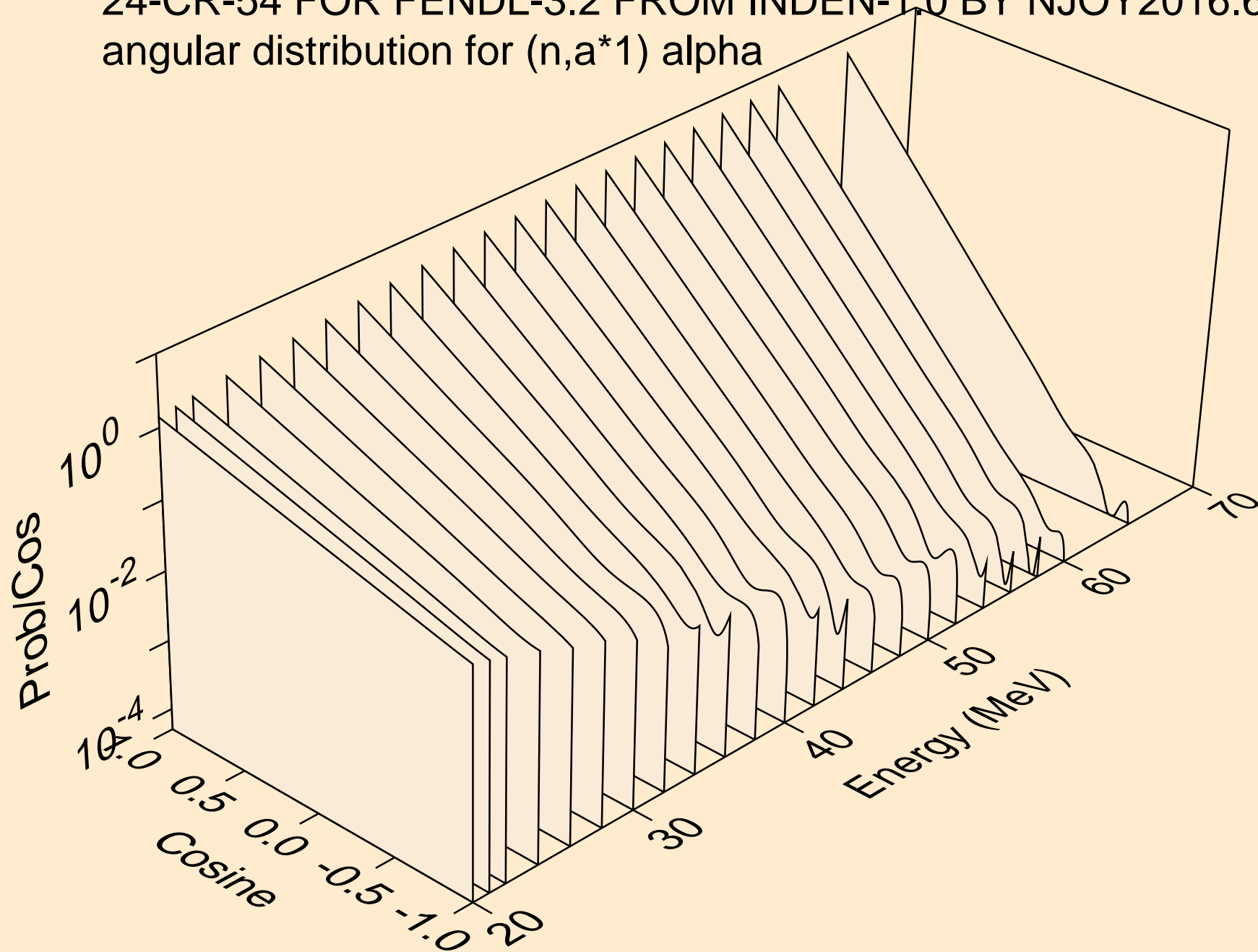

24-CR-54 FOR FENDL-3.2 FROM INDEN-1.0 BY NJOY2016.60+ OI
angular distribution for (n,a*2) alpha

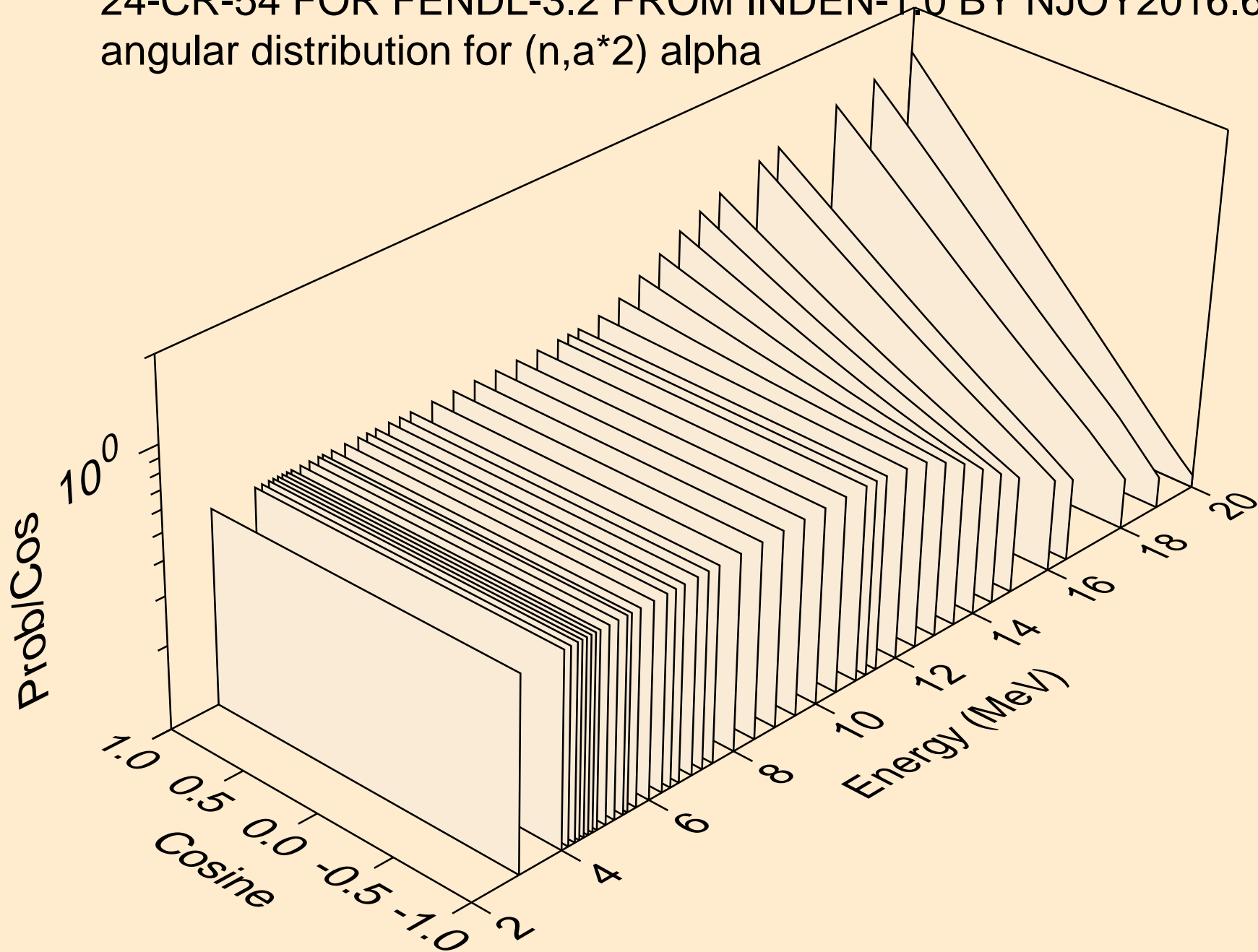

24-CR-54 FOR FENDL-3.2 FROM INDEN-1.0 BY NJOY2016.60+ OI
angular distribution for (n,a*2) alpha

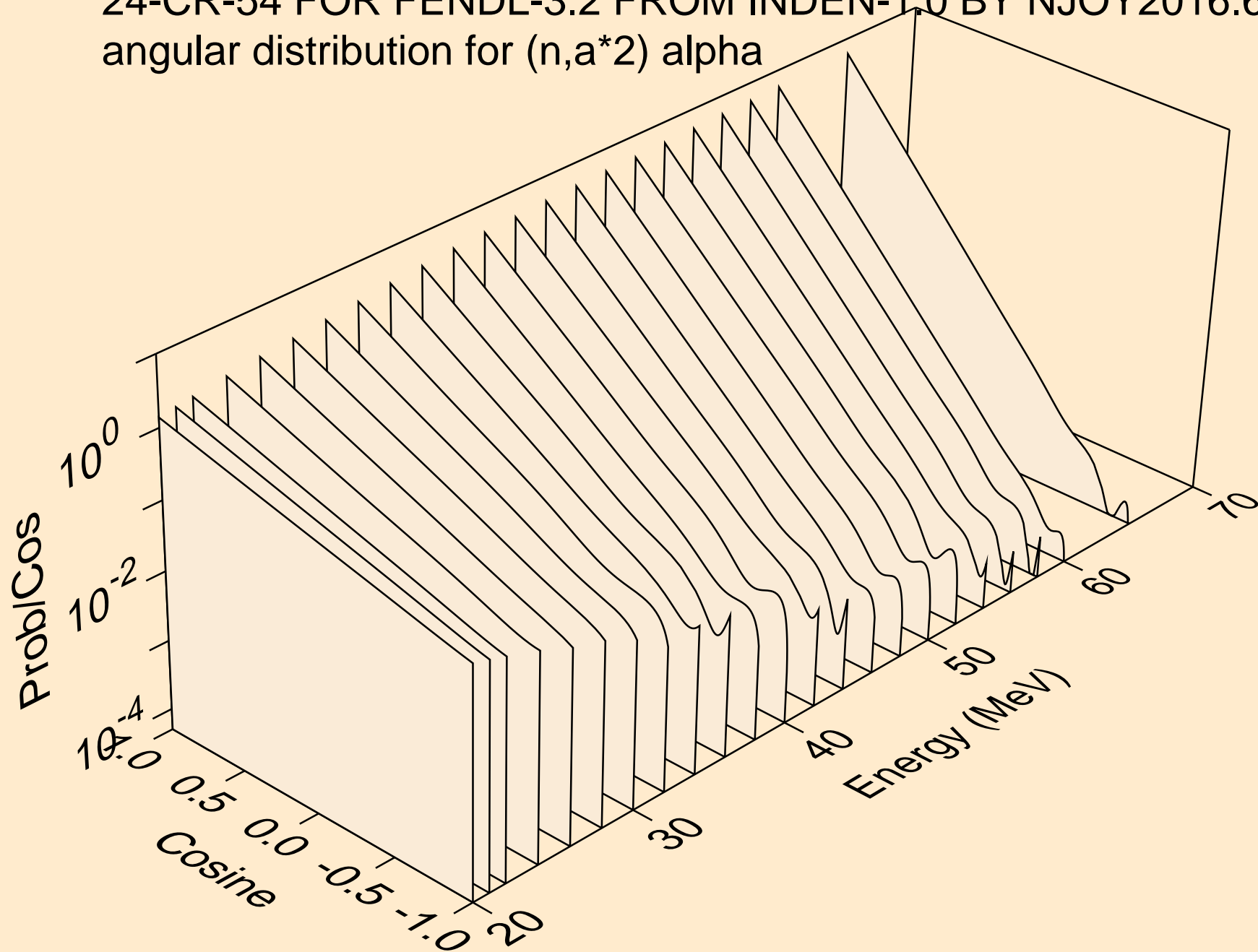

24-CR-54 FOR FENDL-3.2 FROM INDEN-1.0 BY NJOY2016.60+ OI
angular distribution for (n,a*3) alpha

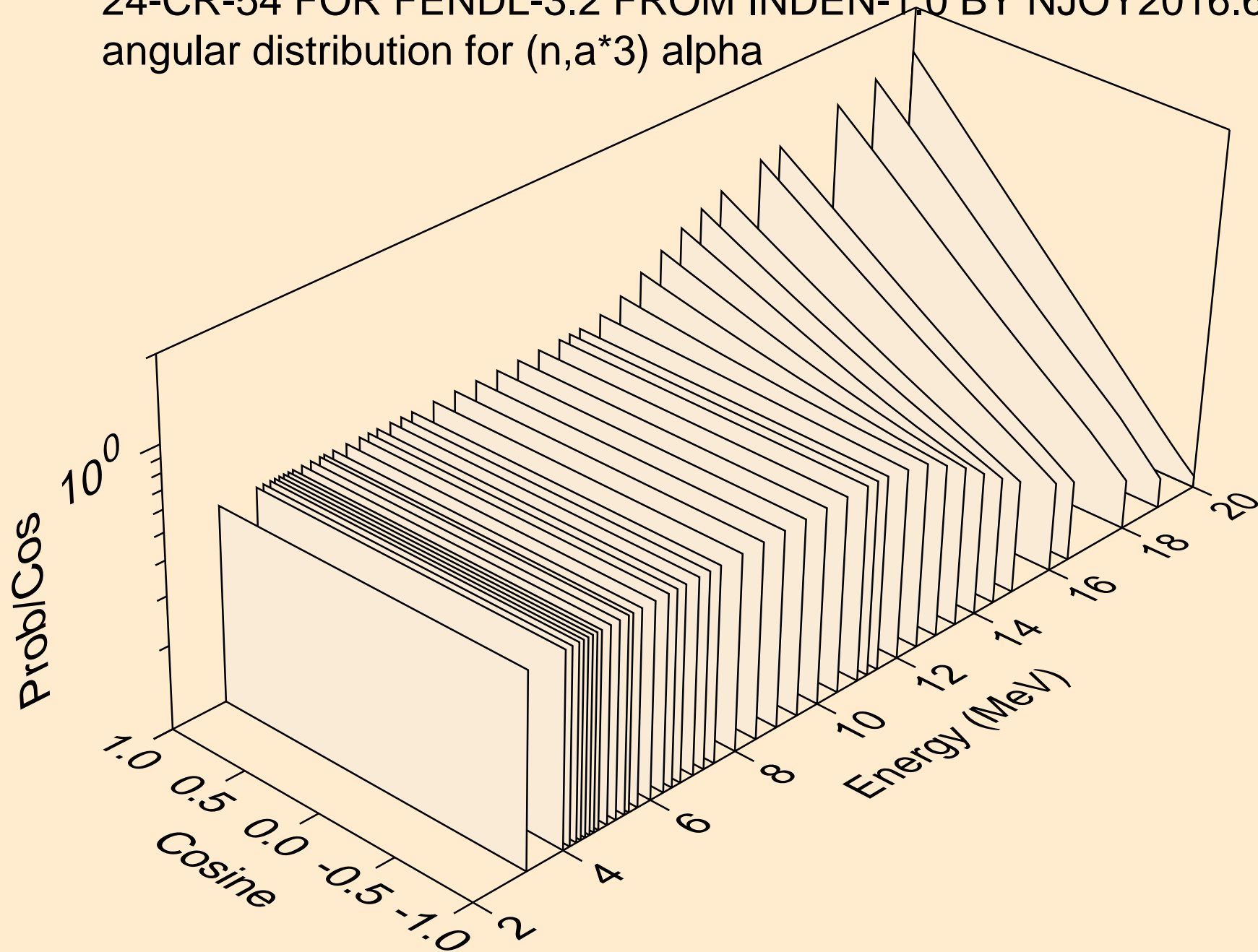

24-CR-54 FOR FENDL-3.2 FROM INDEN-1.0 BY NJOY2016.60+ OI
angular distribution for (n,a*3) alpha

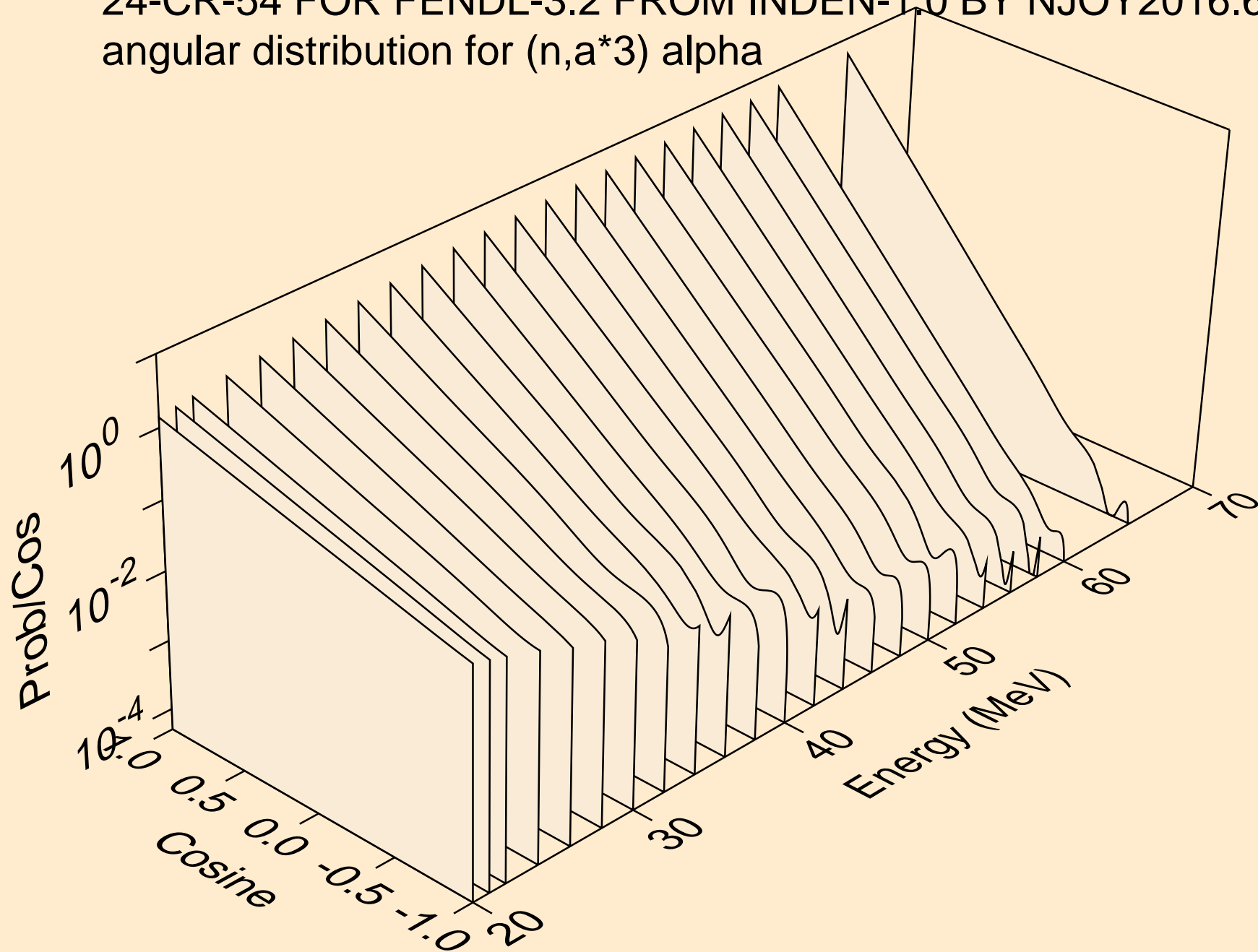

24-CR-54 FOR FENDL-3.2 FROM INDEN-1.0 BY NJOY2016.60+ OI
angular distribution for (n,a*4) alpha

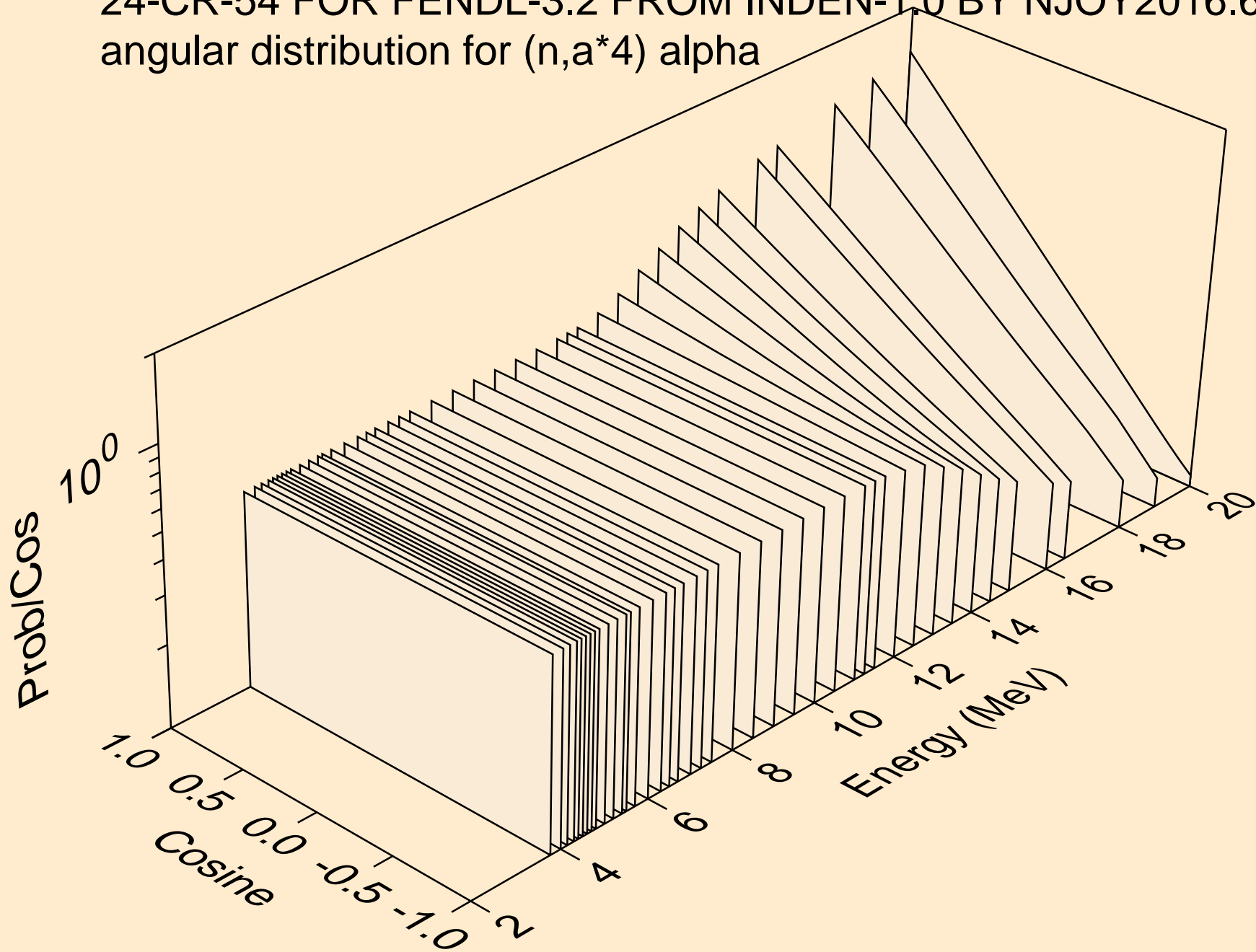

24-CR-54 FOR FENDL-3.2 FROM INDEN-1.0 BY NJOY2016.60+ OI
angular distribution for (n,a*4) alpha

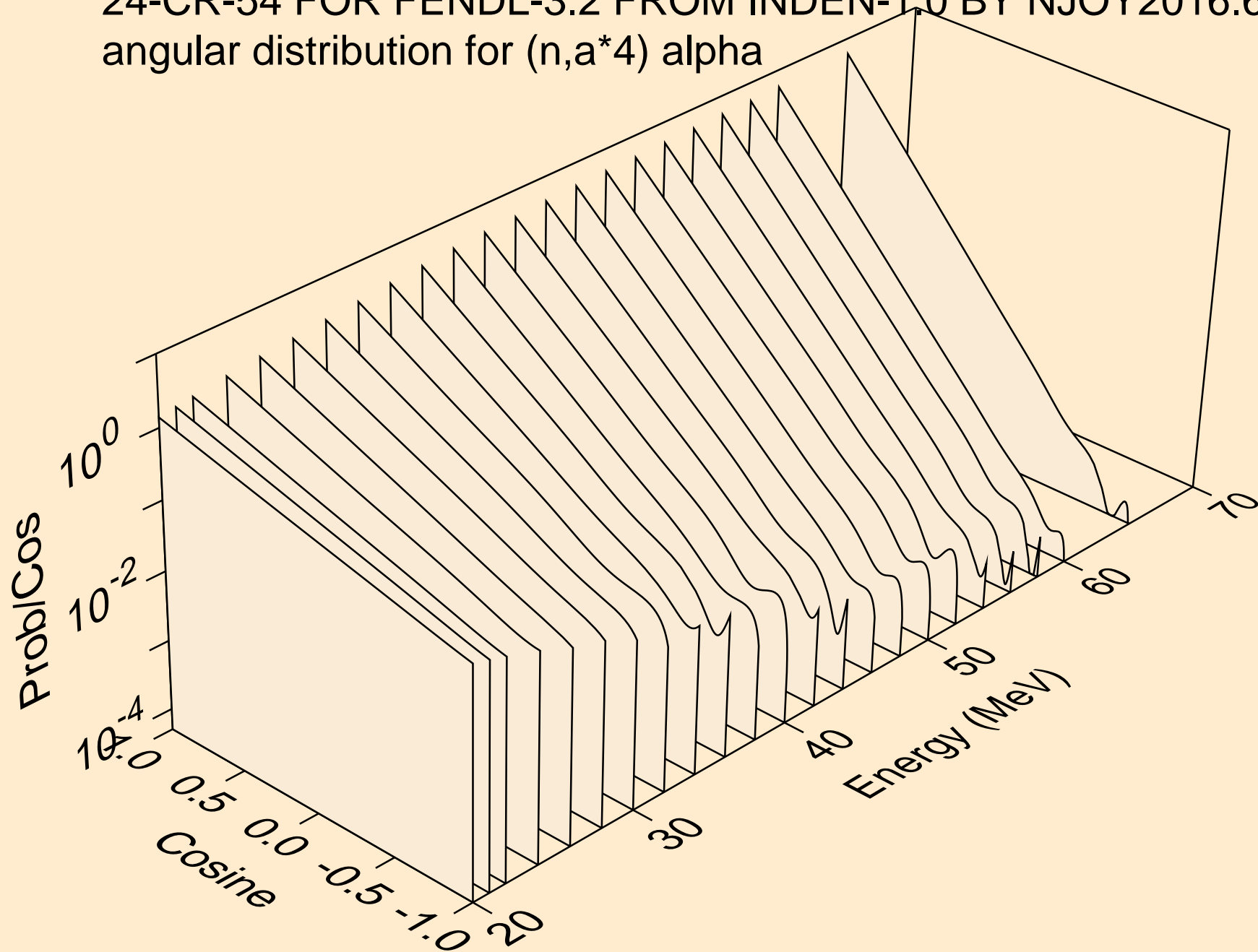

24-CR-54 FOR FENDL-3.2 FROM INDEN-1.0 BY NJOY2016.60+ OI
angular distribution for (n,a*5) alpha

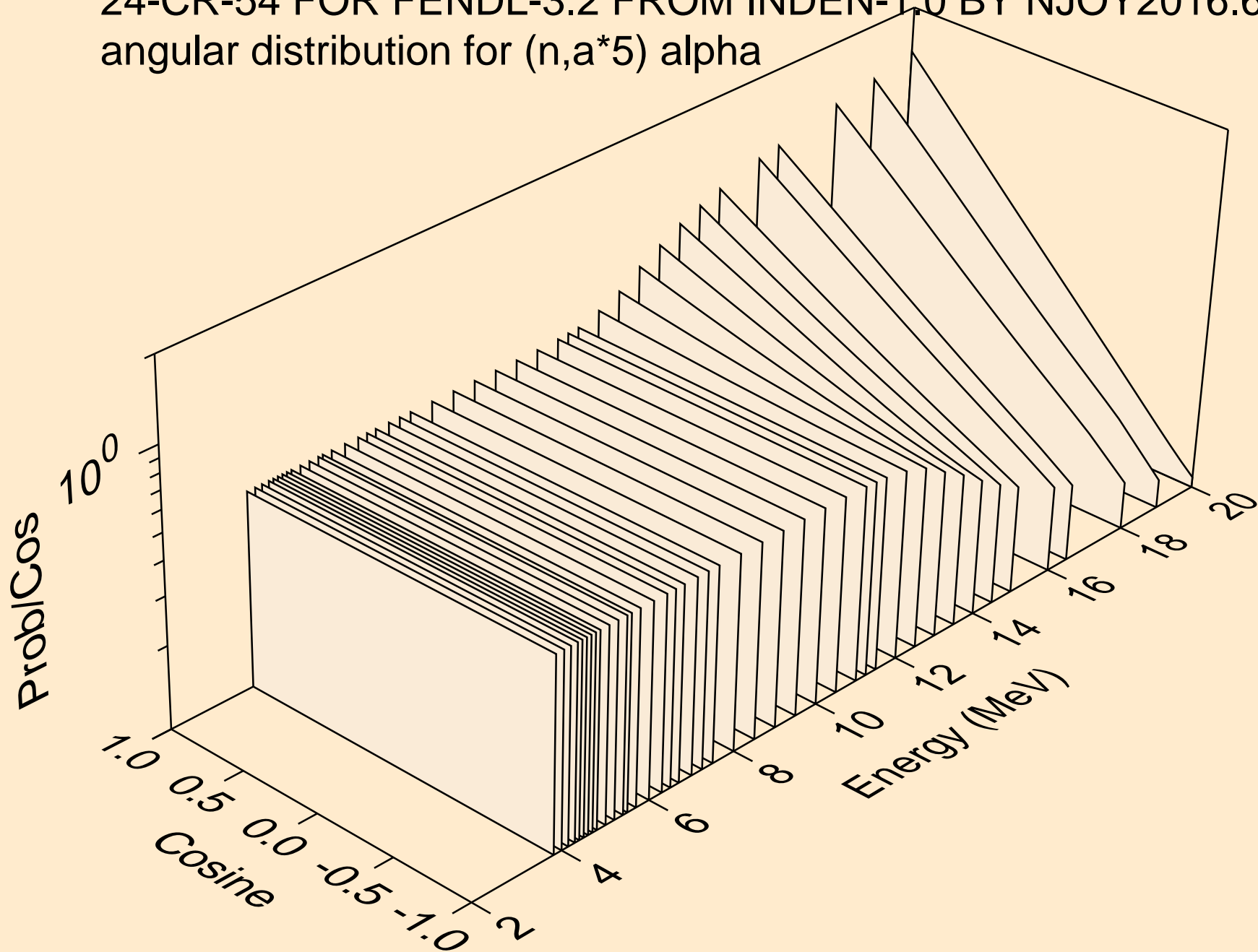

24-CR-54 FOR FENDL-3.2 FROM INDEN-1.0 BY NJOY2016.60+ OI
angular distribution for (n,a*5) alpha

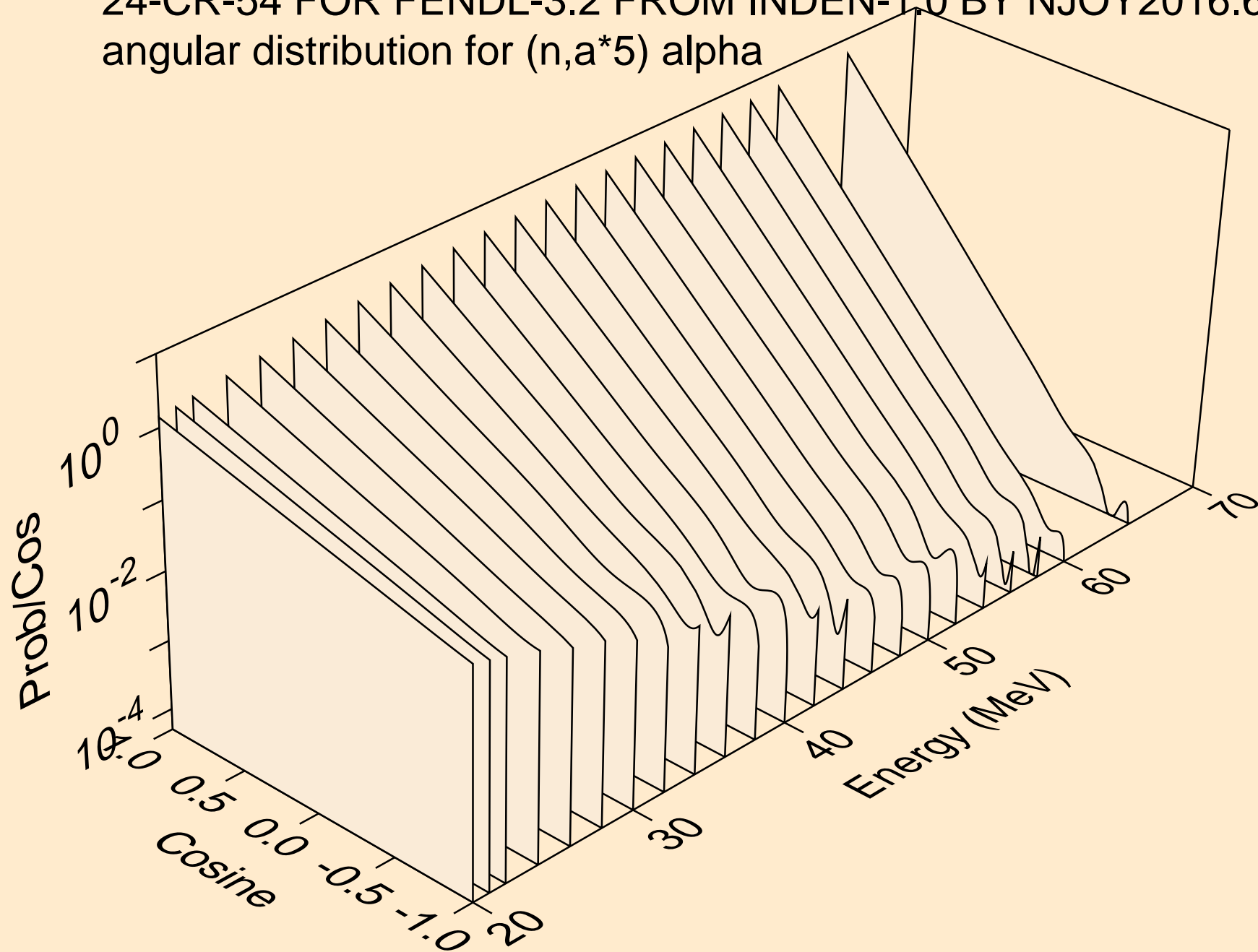

24-CR-54 FOR FENDL-3.2 FROM INDEN-1.0 BY NJOY2016.60+ OI
angular distribution for (n,a*6) alpha

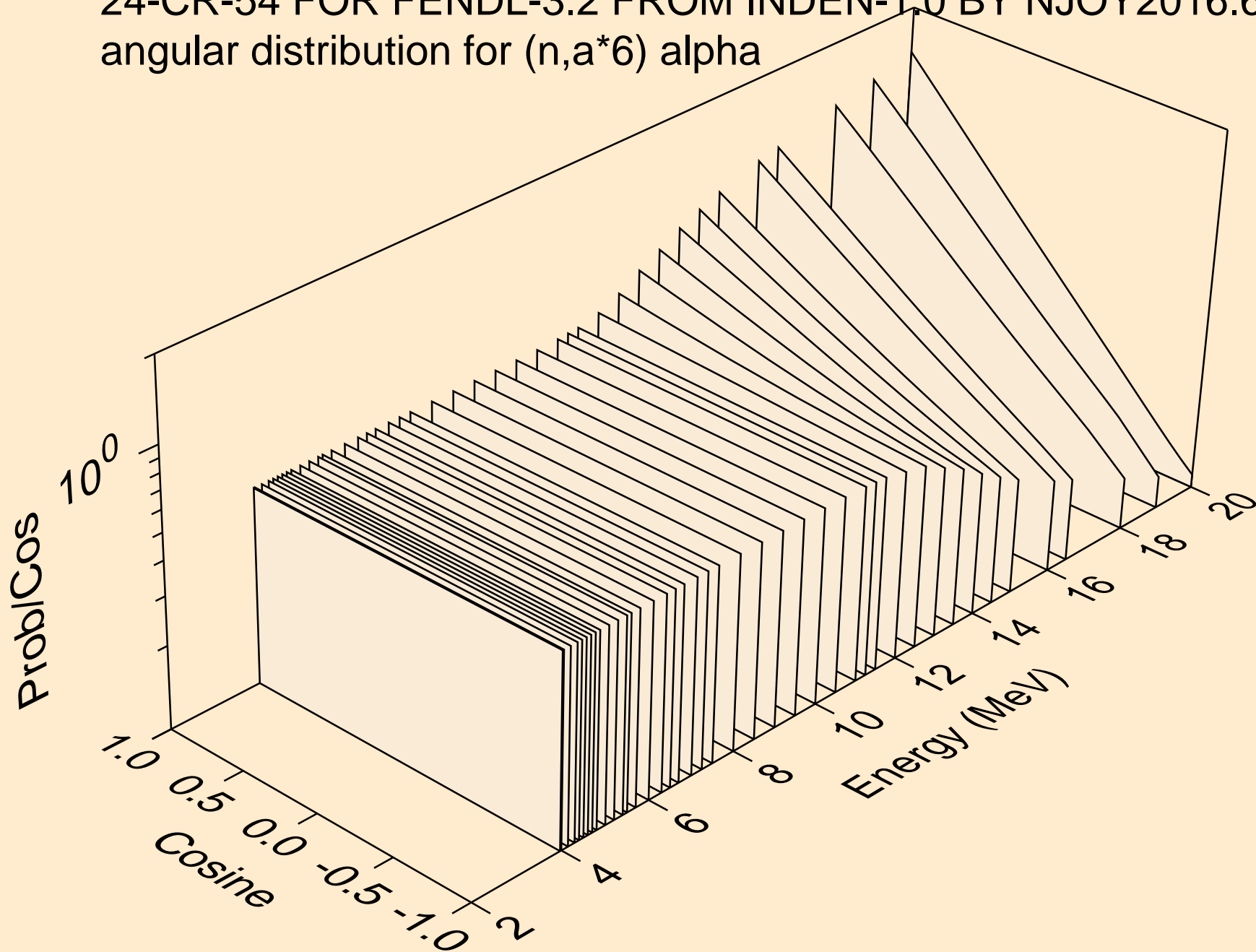

24-CR-54 FOR FENDL-3.2 FROM INDEN-1.0 BY NJOY2016.60+ OI
angular distribution for (n,a*6) alpha

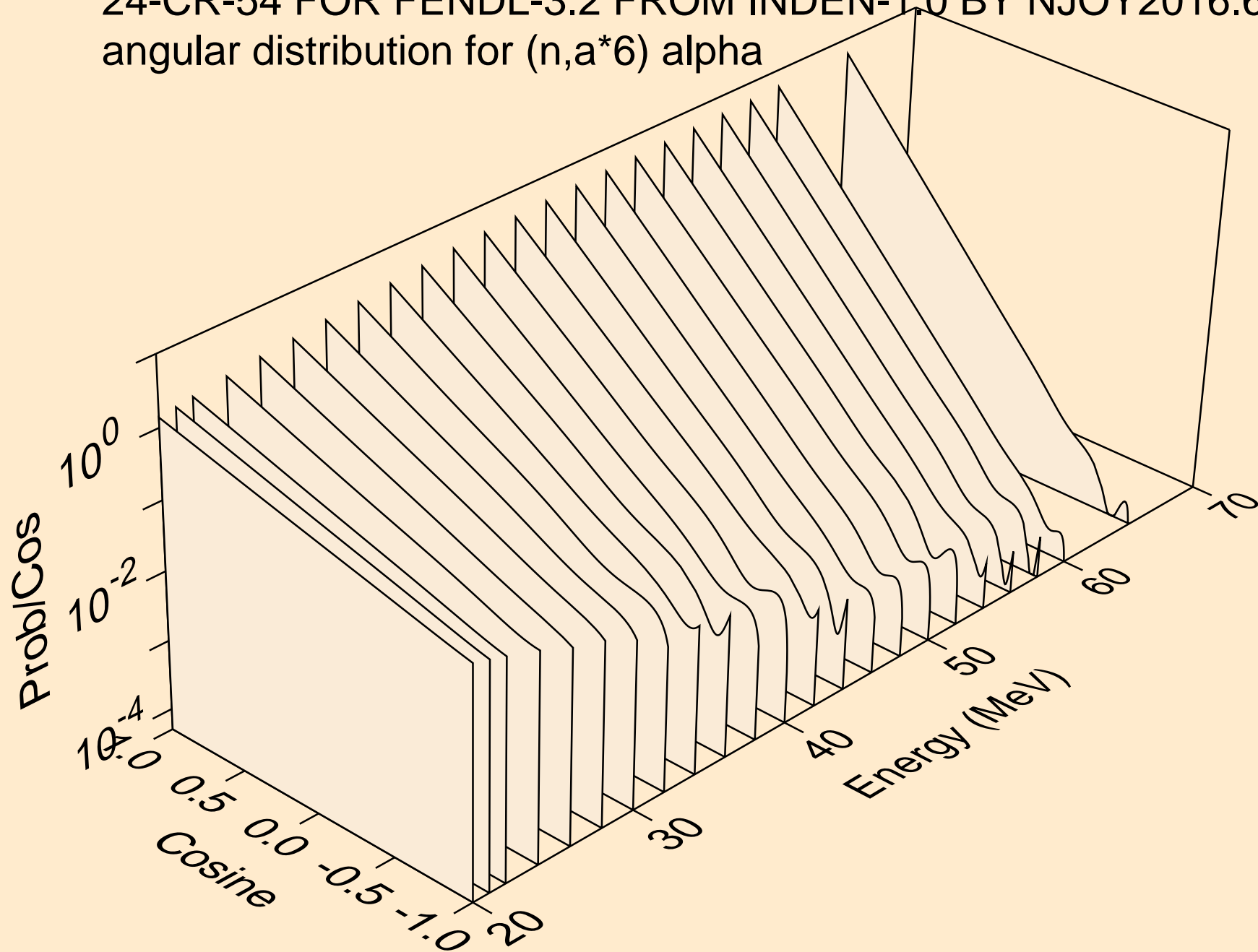

24-CR-54 FOR FENDL-3.2 FROM INDEN-1.0 BY NJOY2016.60+ OI
angular distribution for (n,a*7) alpha

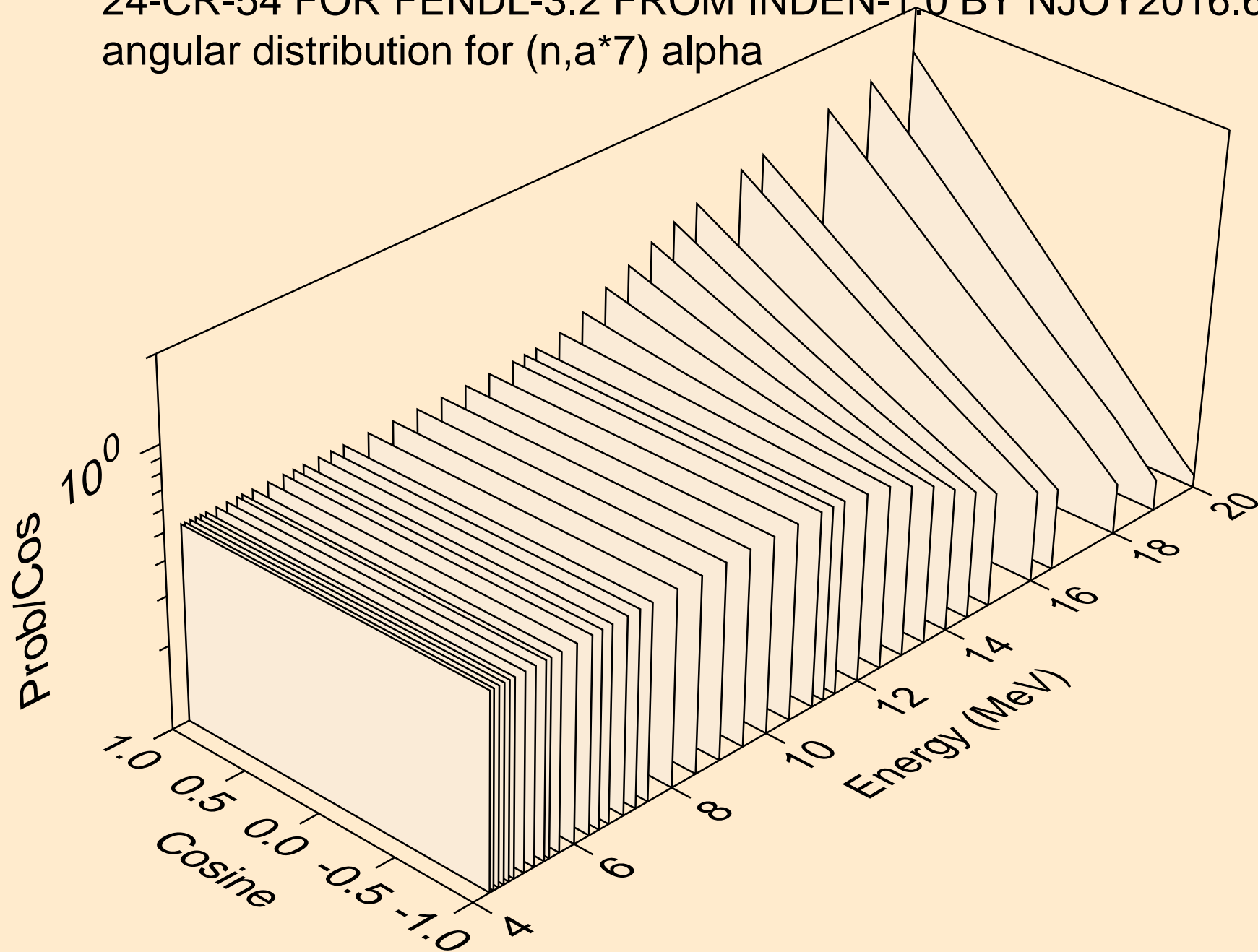

24-CR-54 FOR FENDL-3.2 FROM INDEN-1.0 BY NJOY2016.60+ OI
angular distribution for (n,a*7) alpha

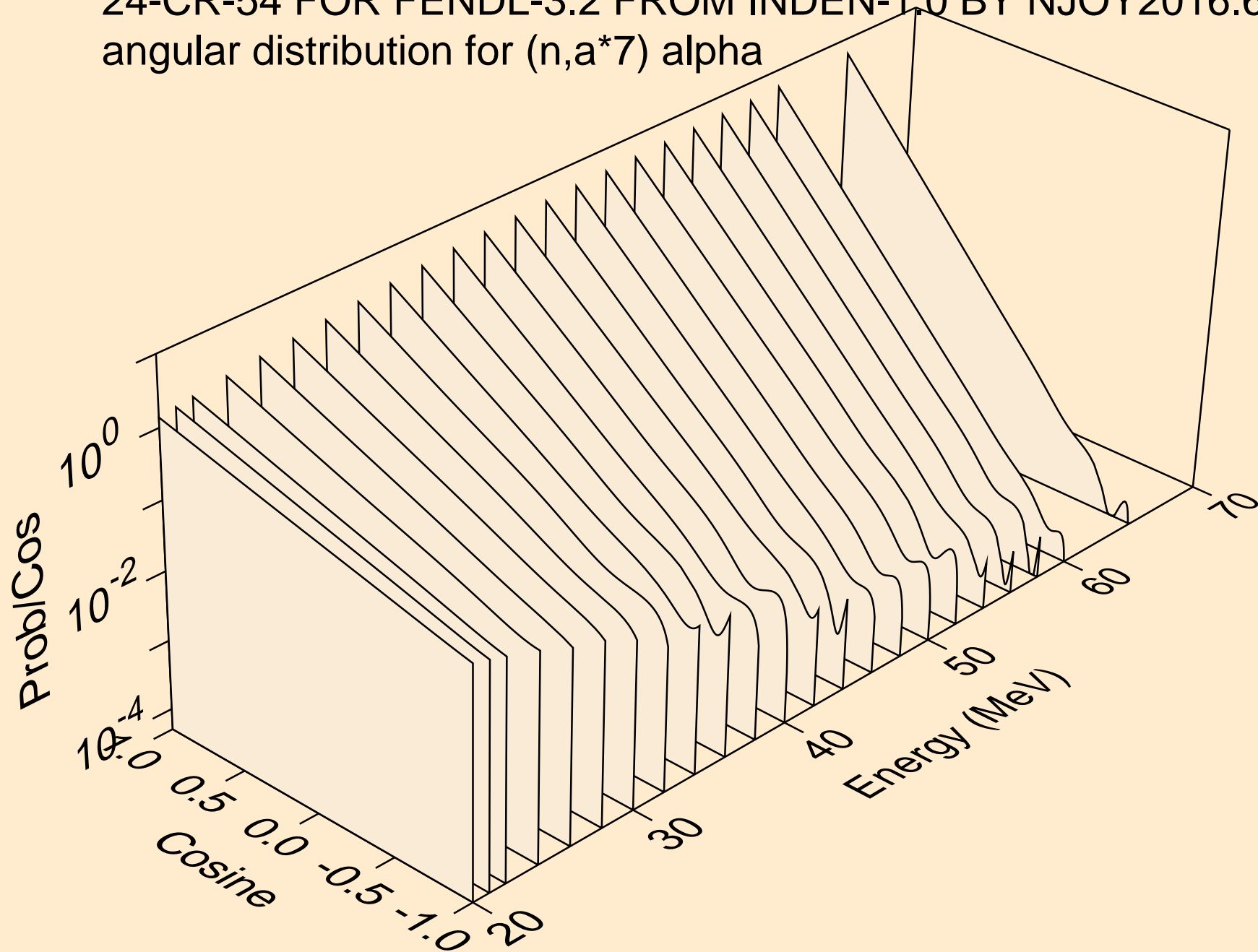

24-CR-54 FOR FENDL-3.2 FROM INDEN-1.0 BY NJOY2016.60+ OI
angular distribution for (n,a*8) alpha

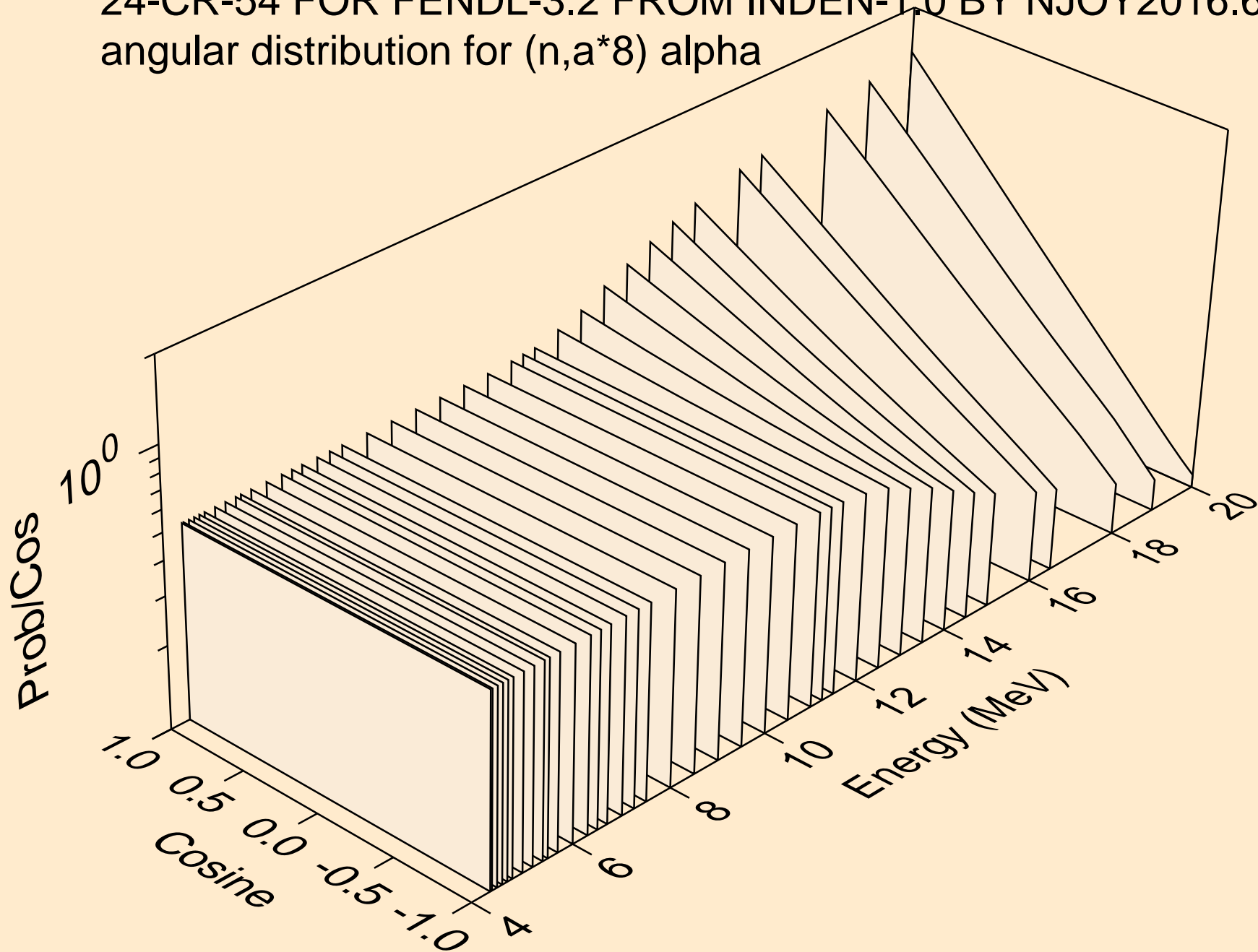

24-CR-54 FOR FENDL-3.2 FROM INDEN-1.0 BY NJOY2016.60+ OI
angular distribution for (n,a*8) alpha

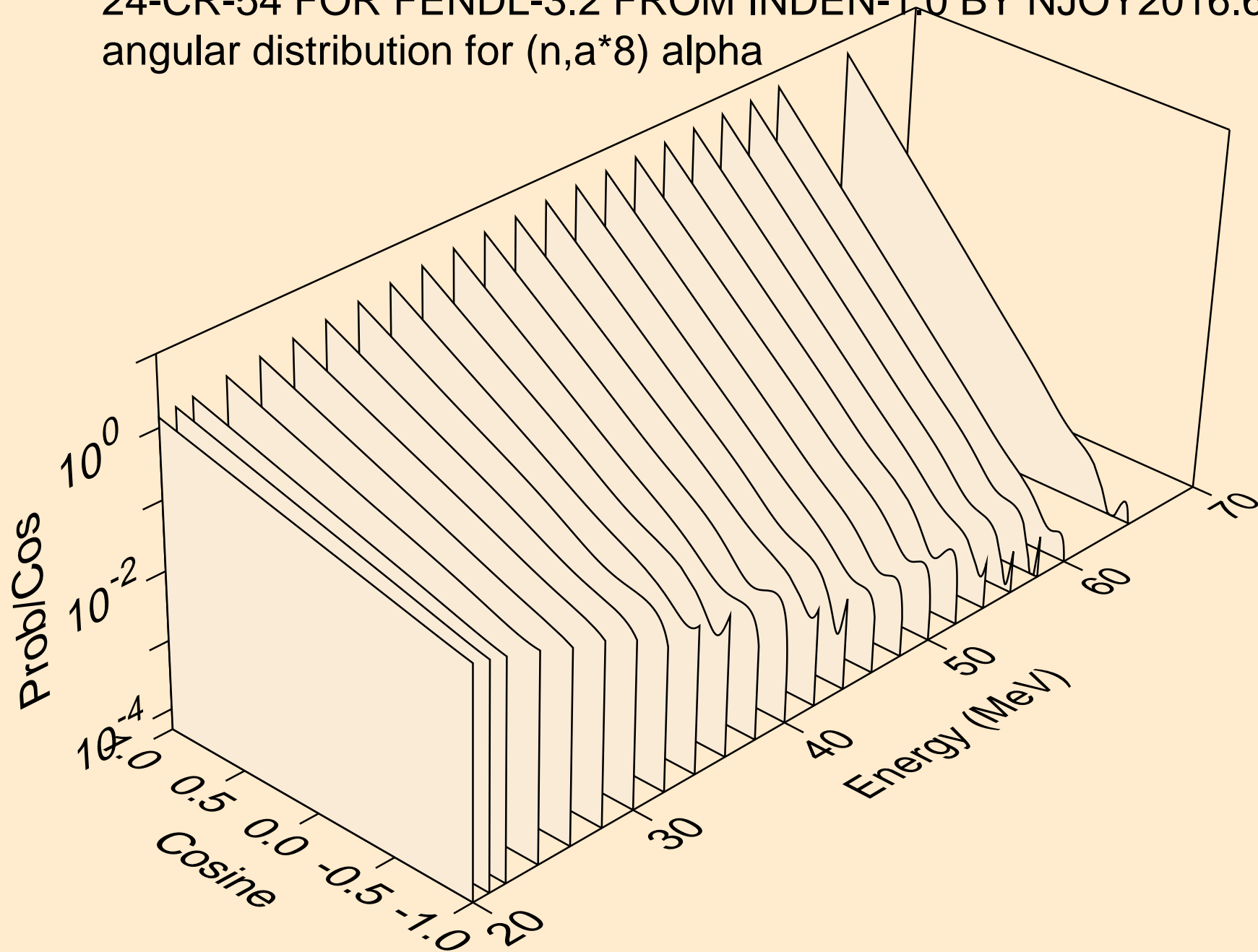

24-CR-54 FOR FENDL-3.2 FROM INDEN-1.0 BY NJOY2016.60+ OI
angular distribution for (n,a*9) alpha

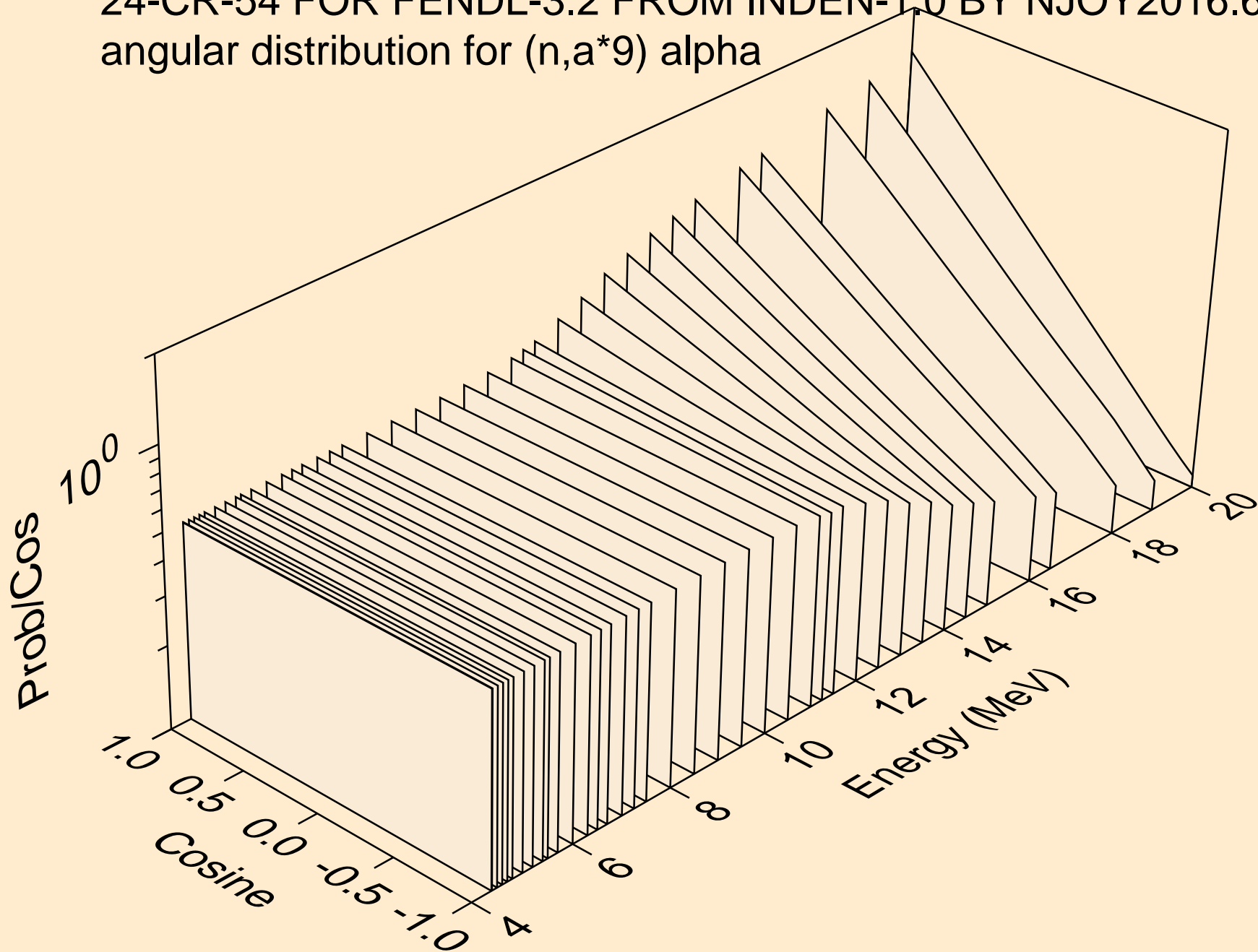

24-CR-54 FOR FENDL-3.2 FROM INDEN-1.0 BY NJOY2016.60+ OI
angular distribution for (n,a*9) alpha

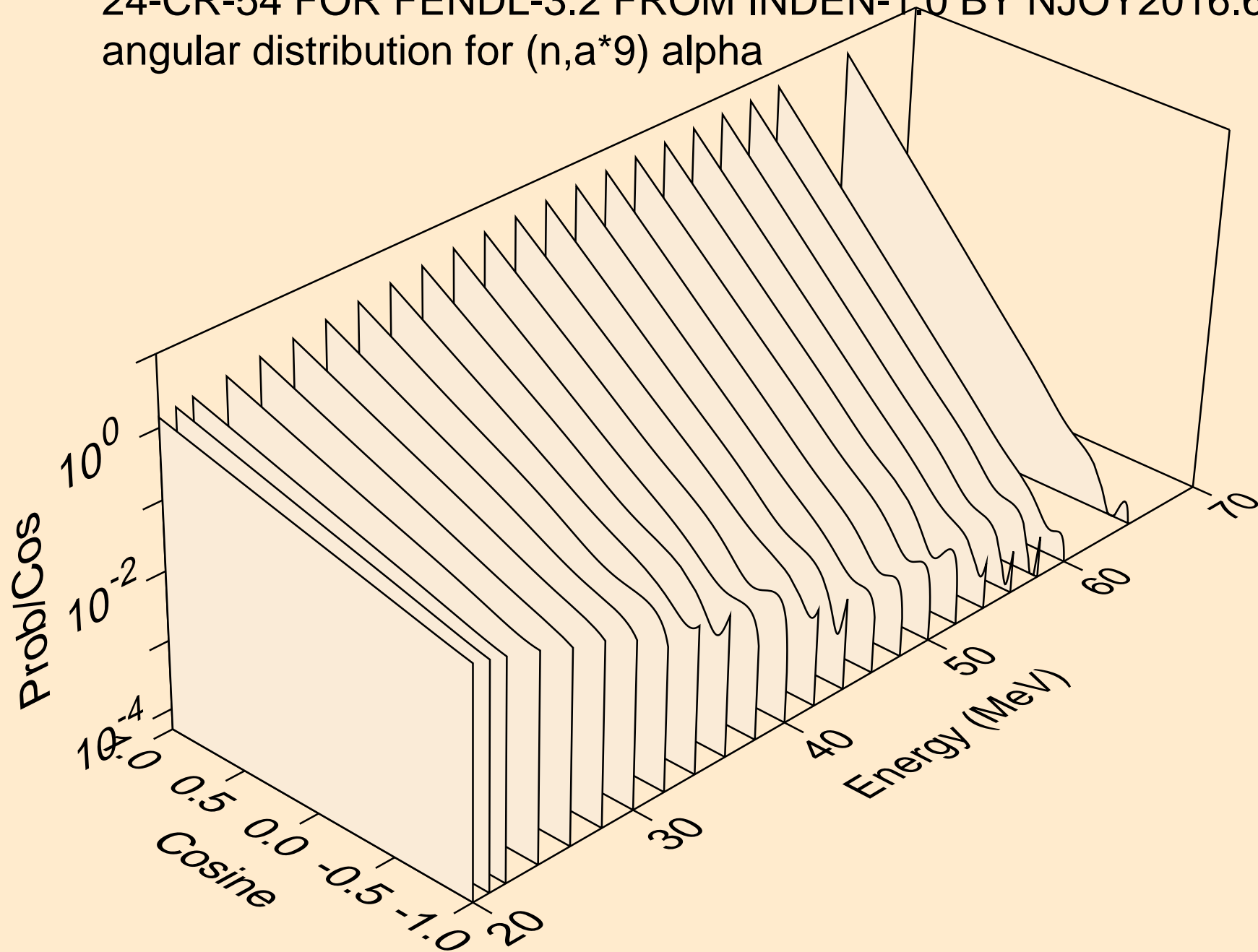

24-CR-54 FOR FENDL-3.2 FROM INDEN-1.0 BY NJOY2016.60+ OI
angular distribution for (n,a*10) alpha

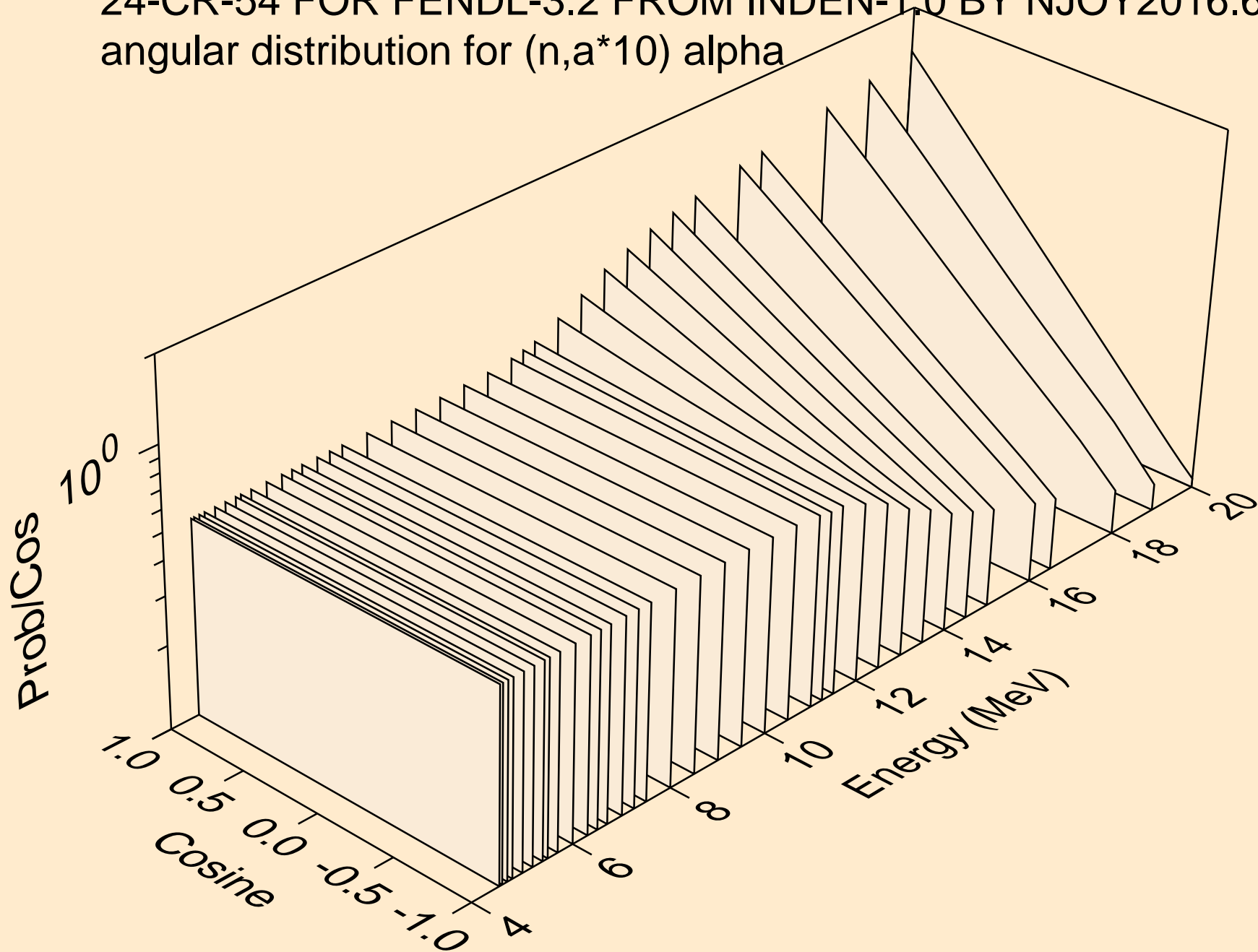

24-CR-54 FOR FENDL-3.2 FROM INDEN-1.0 BY NJOY2016.60+ OI
angular distribution for (n,a*10) alpha

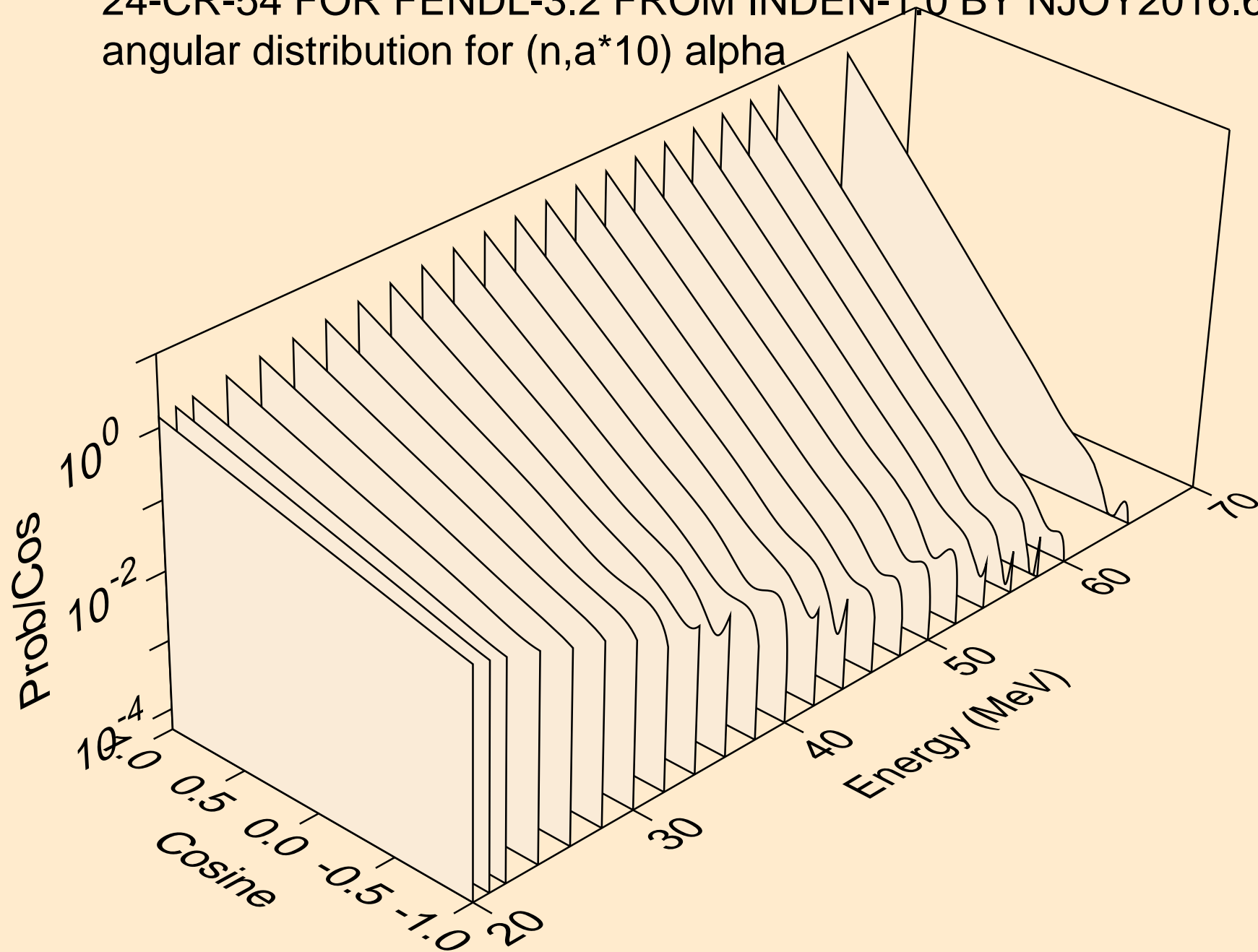

24-CR-54 FOR FENDL-3.2 FROM INDEN-1.0 BY NJOY2016.60+ OI
angular distribution for (n,a*11) alpha

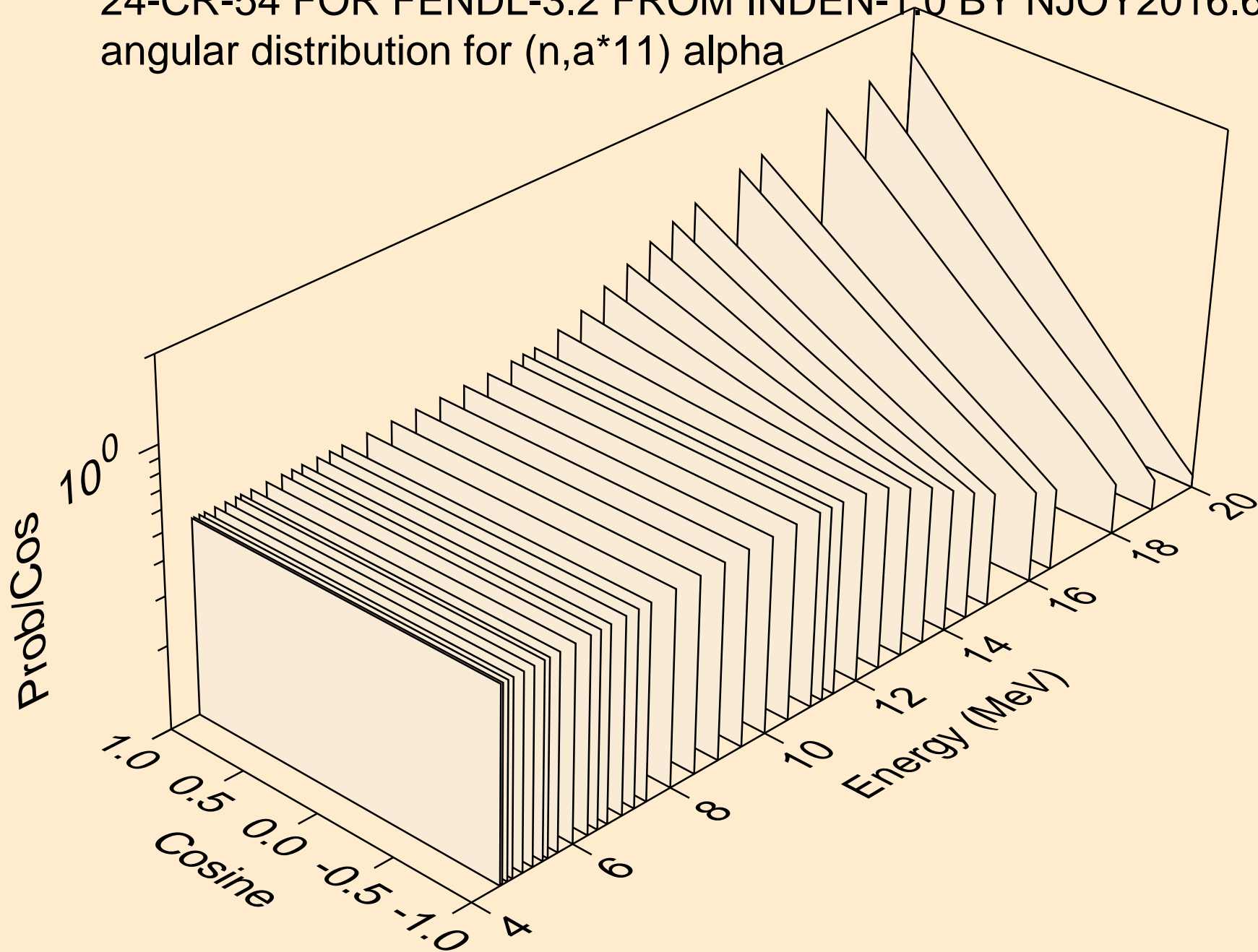

24-CR-54 FOR FENDL-3.2 FROM INDEN-1.0 BY NJOY2016.60+ OI
angular distribution for (n,a*11) alpha

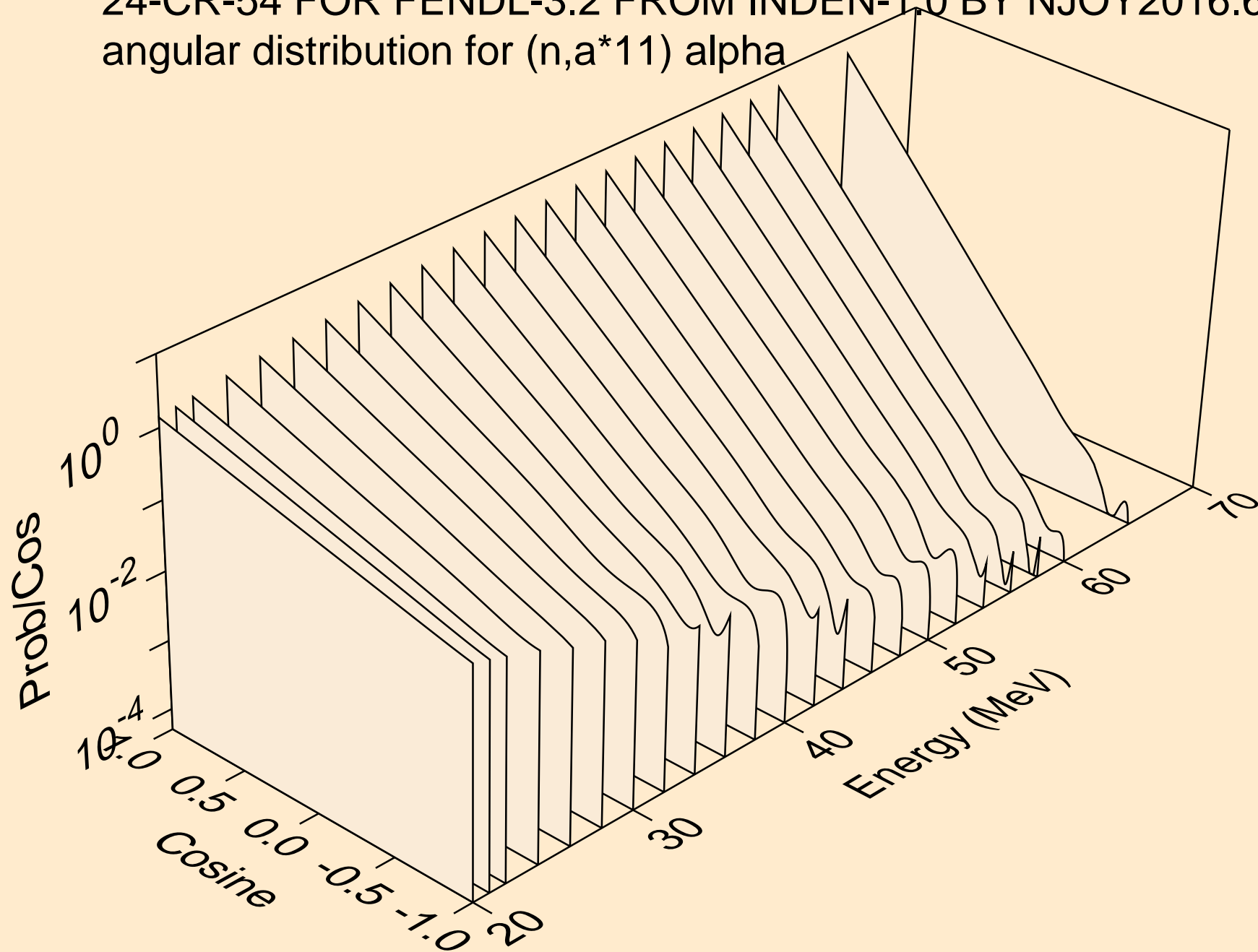

24-CR-54 FOR FENDL-3.2 FROM INDEN-1.0 BY NJOY2016.60+ OI
angular distribution for (n,a*12) alpha

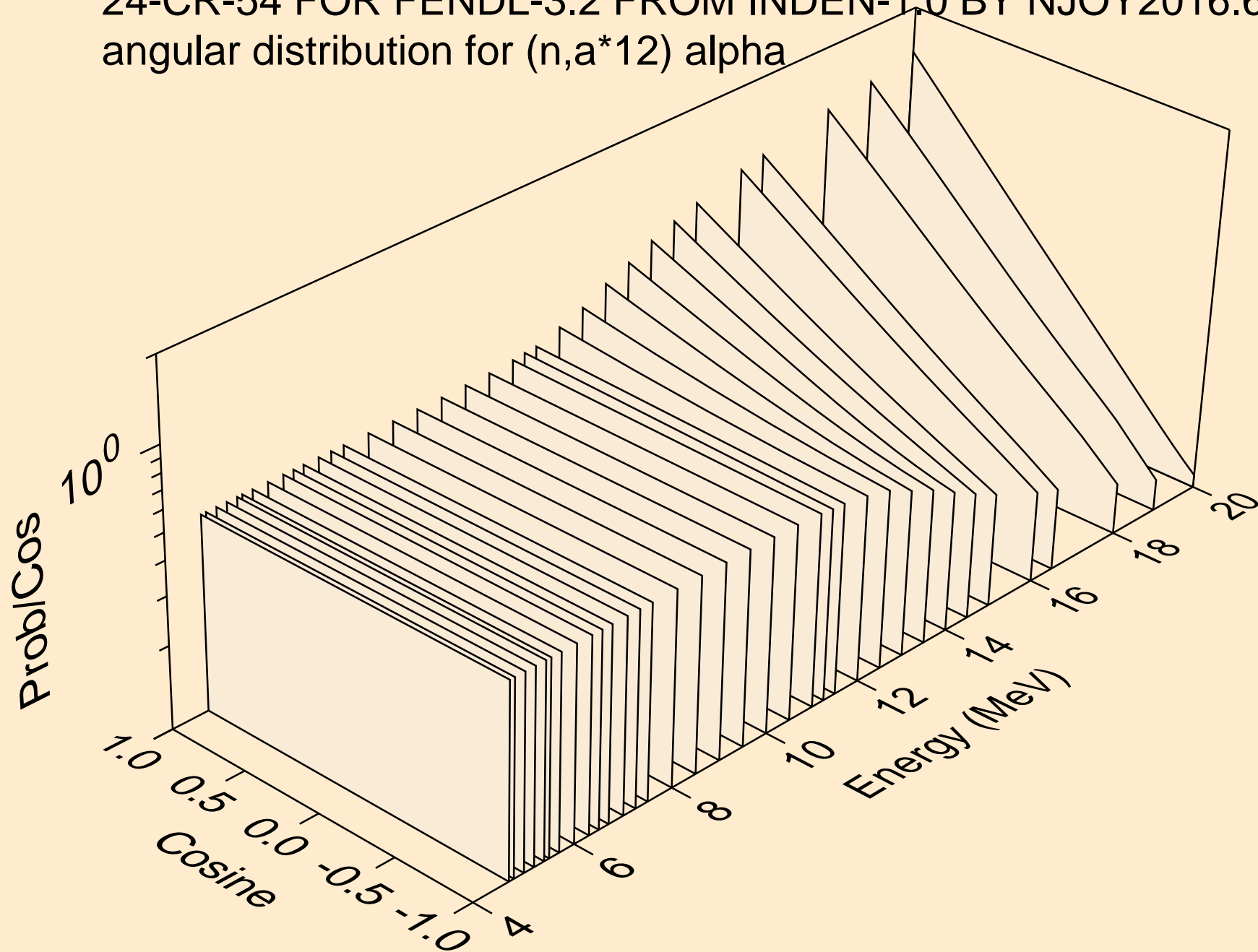

24-CR-54 FOR FENDL-3.2 FROM INDEN-1.0 BY NJOY2016.60+ OI
angular distribution for (n,a*12) alpha

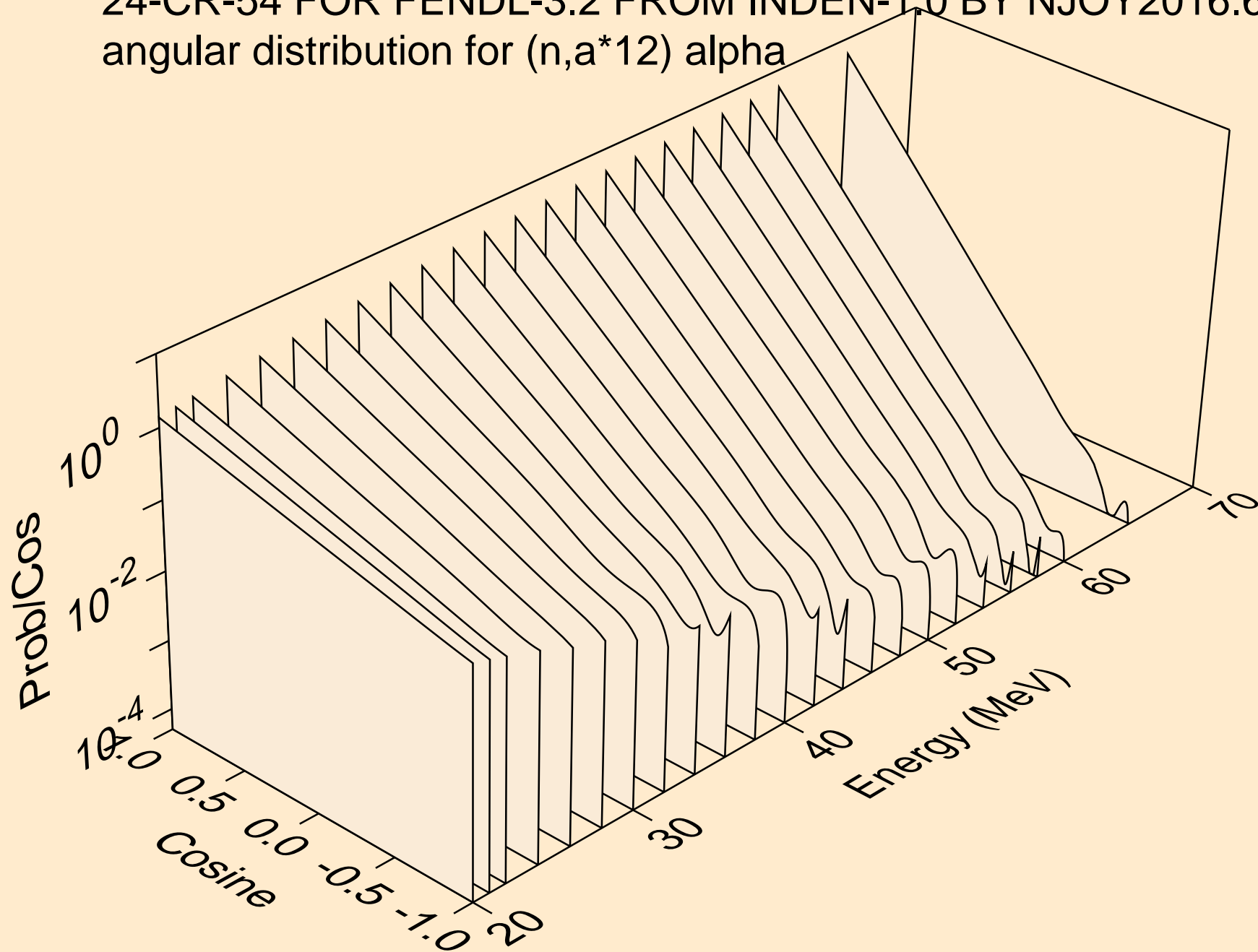

24-CR-54 FOR FENDL-3.2 FROM INDEN-1.0 BY NJOY2016.60+ OI
angular distribution for (n,a*13) alpha

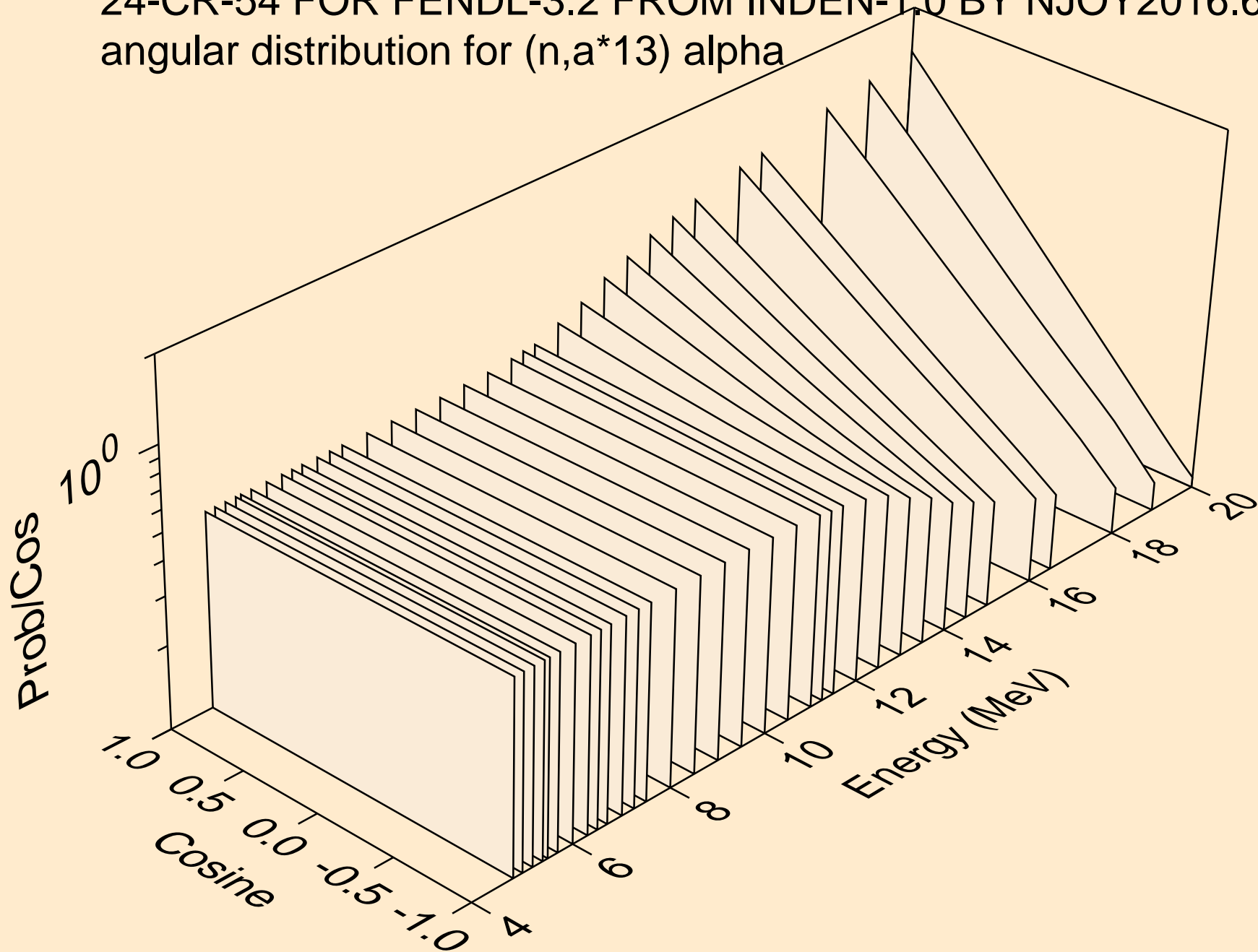

24-CR-54 FOR FENDL-3.2 FROM INDEN-1.0 BY NJOY2016.60+ OI
angular distribution for (n,a*13) alpha

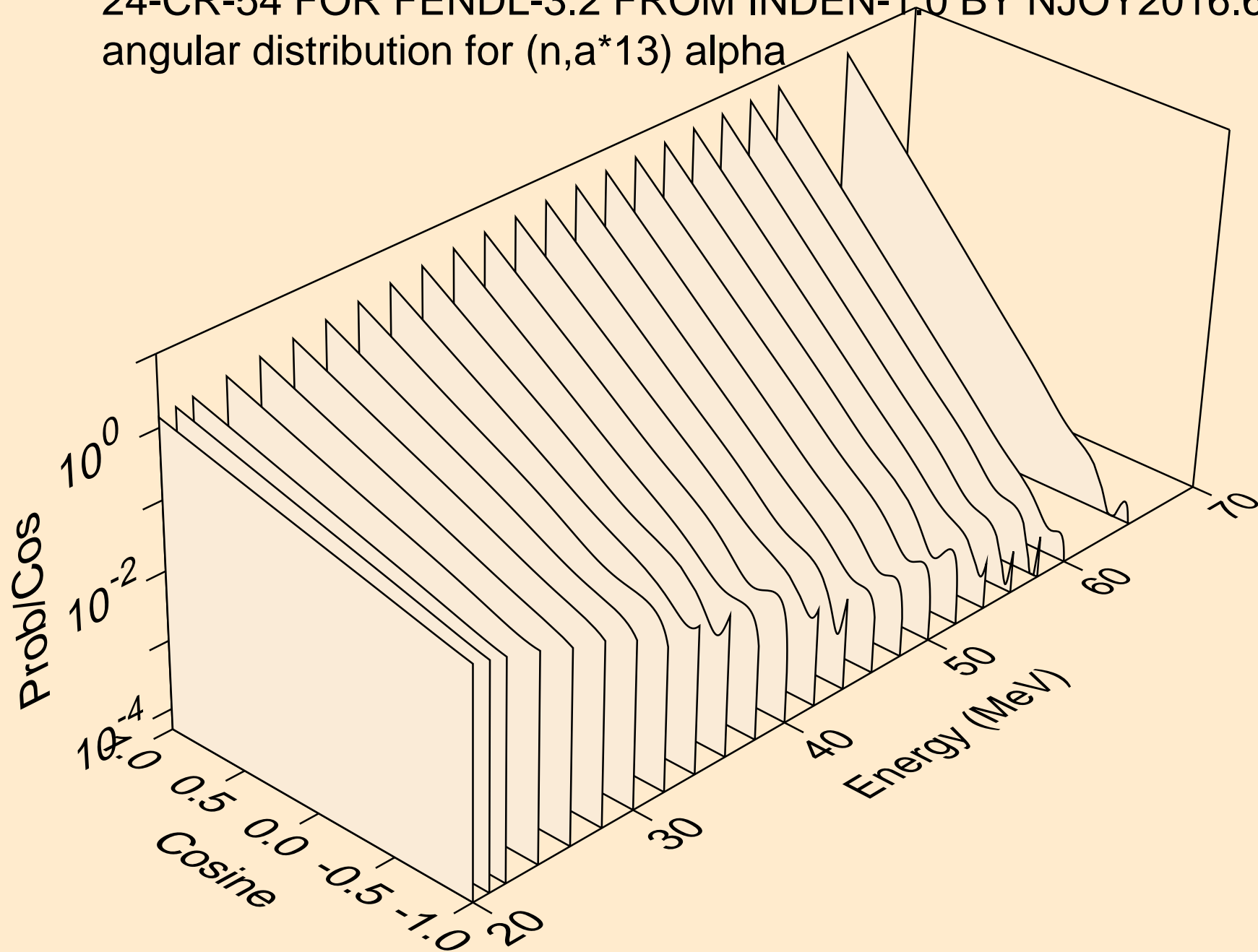

24-CR-54 FOR FENDL-3.2 FROM INDEN-1.0 BY NJOY2016.60+ OI
angular distribution for (n,a*14) alpha

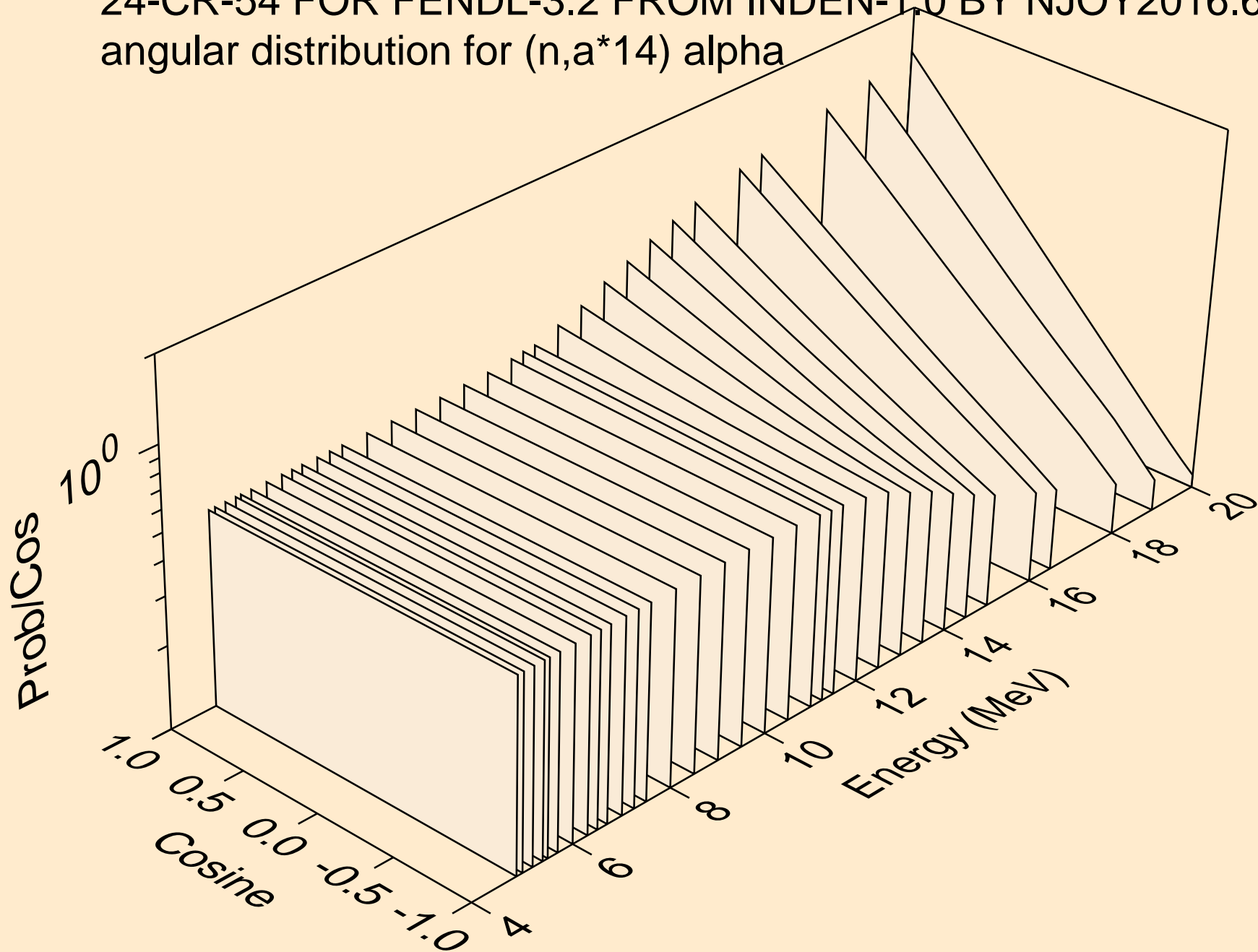

24-CR-54 FOR FENDL-3.2 FROM INDEN-1.0 BY NJOY2016.60+ OI
angular distribution for (n,a*14) alpha

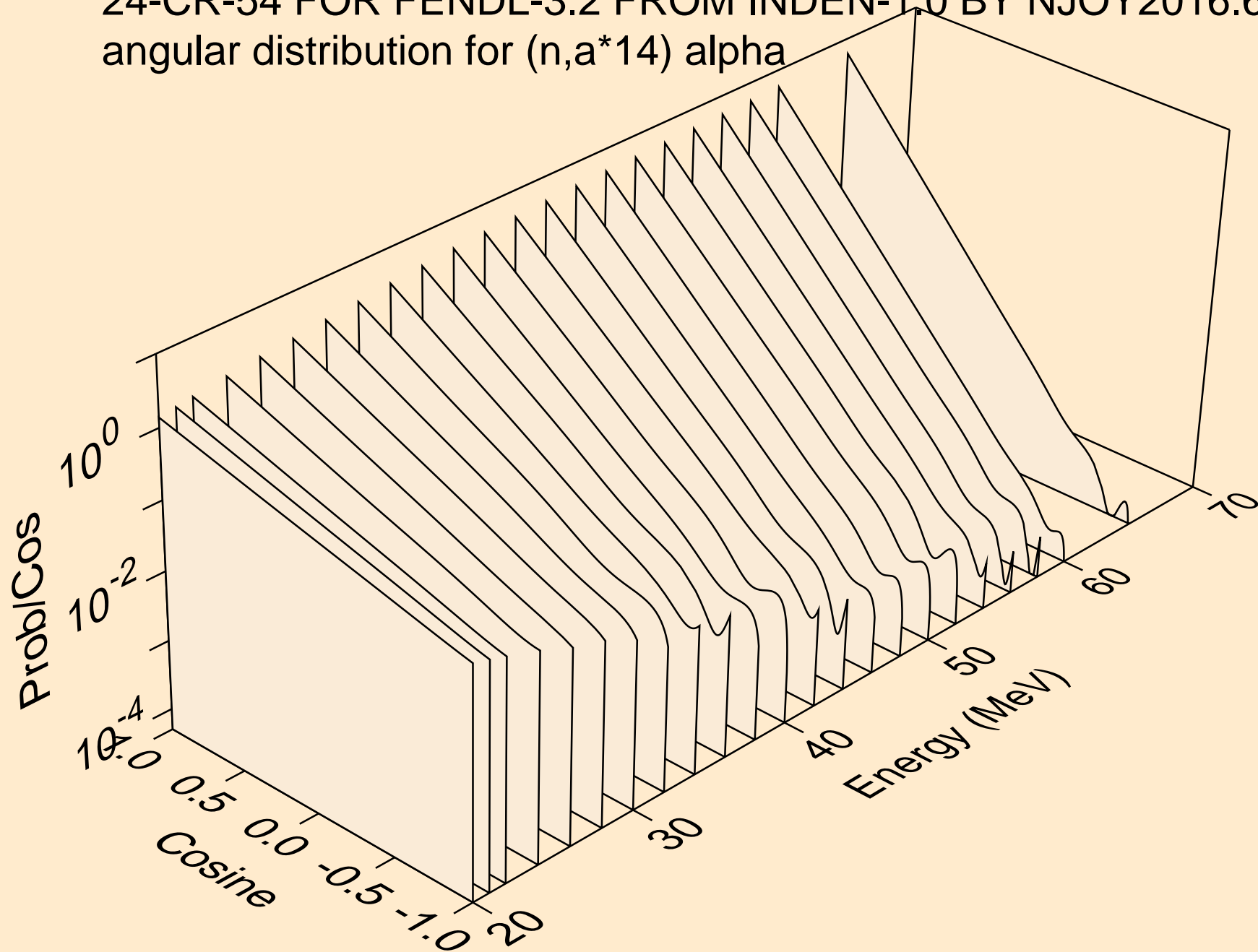

24-CR-54 FOR FENDL-3.2 FROM INDEN-1.0 BY NJOY2016.60+ OI
angular distribution for (n,a*15) alpha

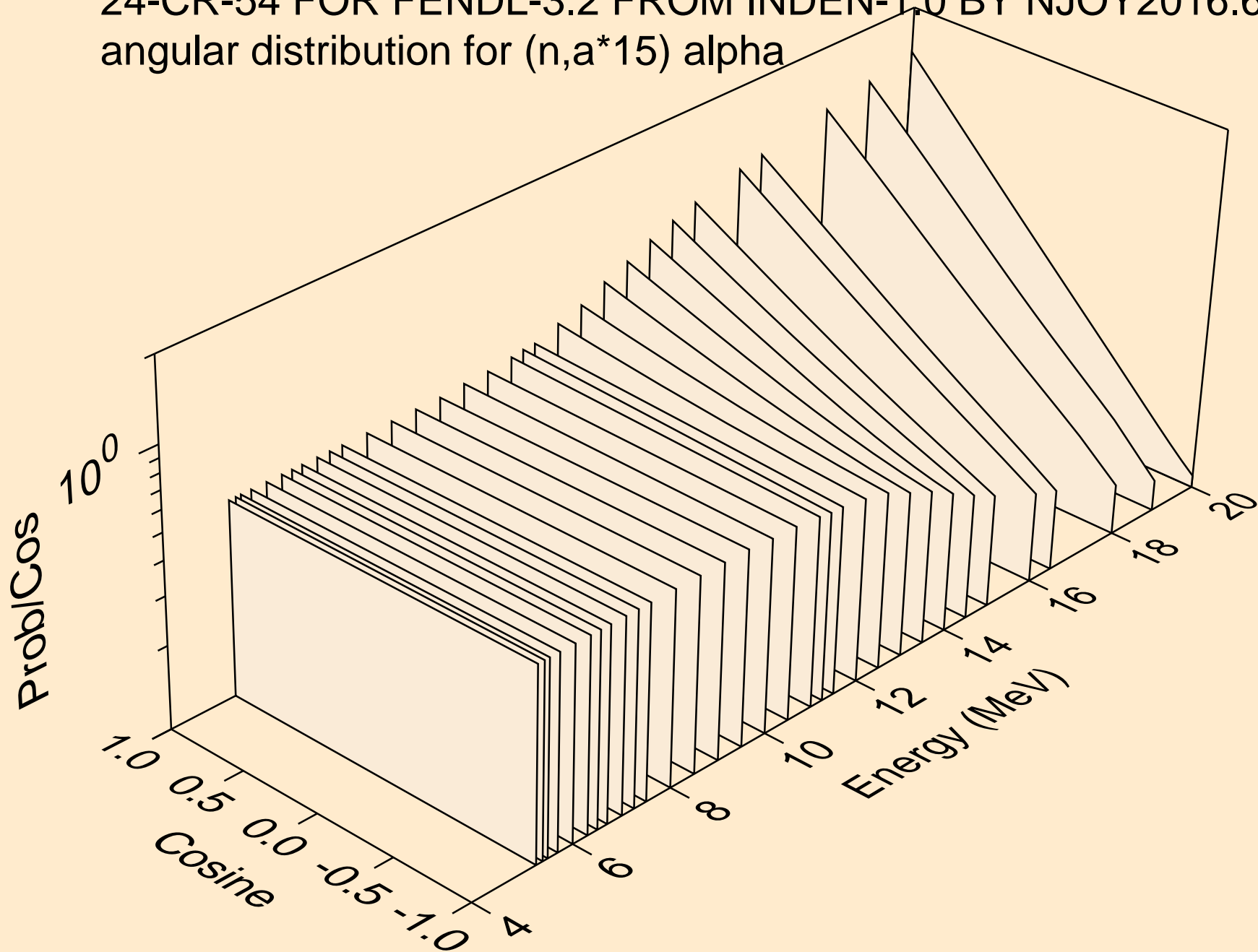

24-CR-54 FOR FENDL-3.2 FROM INDEN-1.0 BY NJOY2016.60+ OI
angular distribution for (n,a*15) alpha

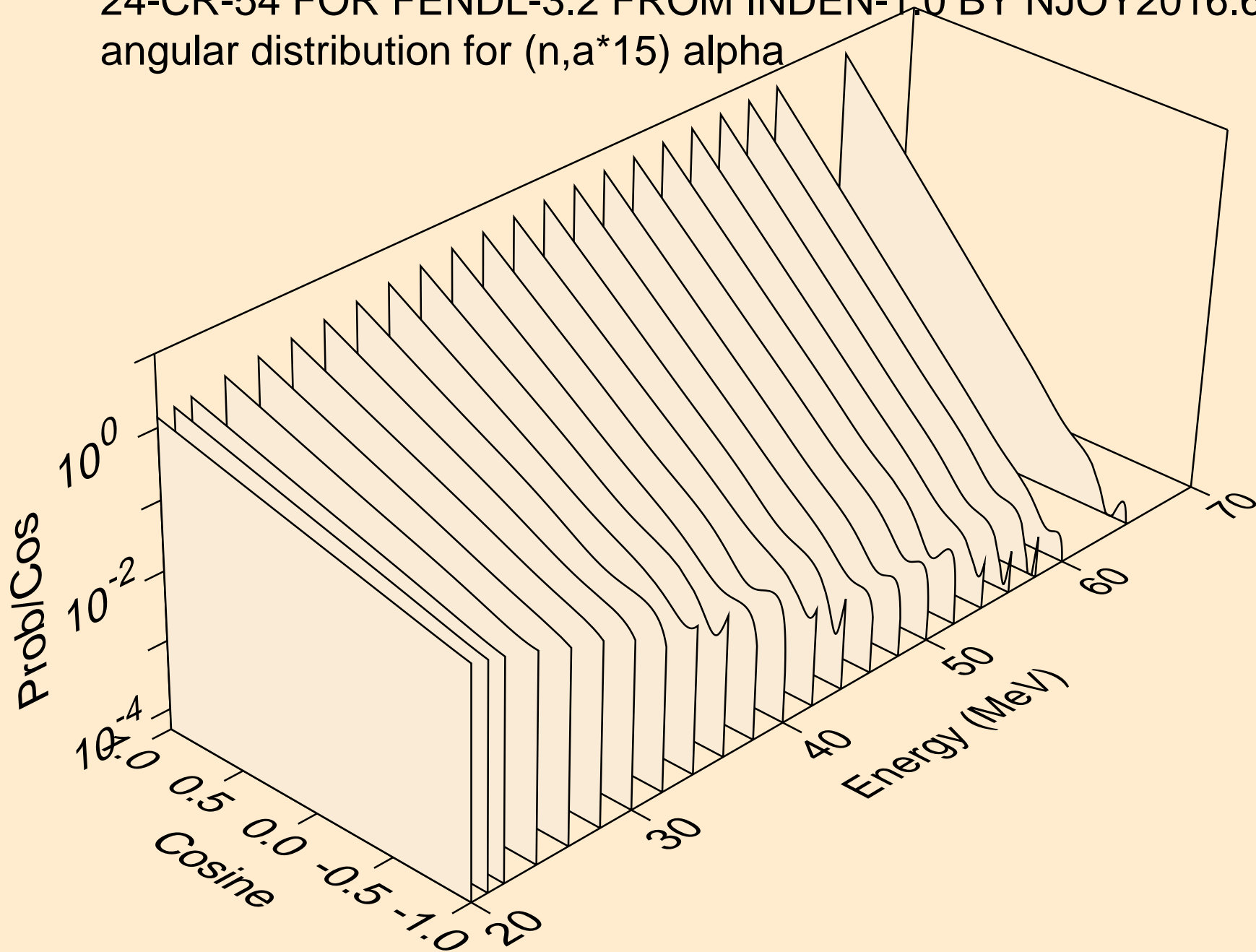

24-CR-54 FOR FENDL-3.2 FROM INDEN-1.0 BY NJOY2016.60+ OI
angular distribution for (n,a*16) alpha

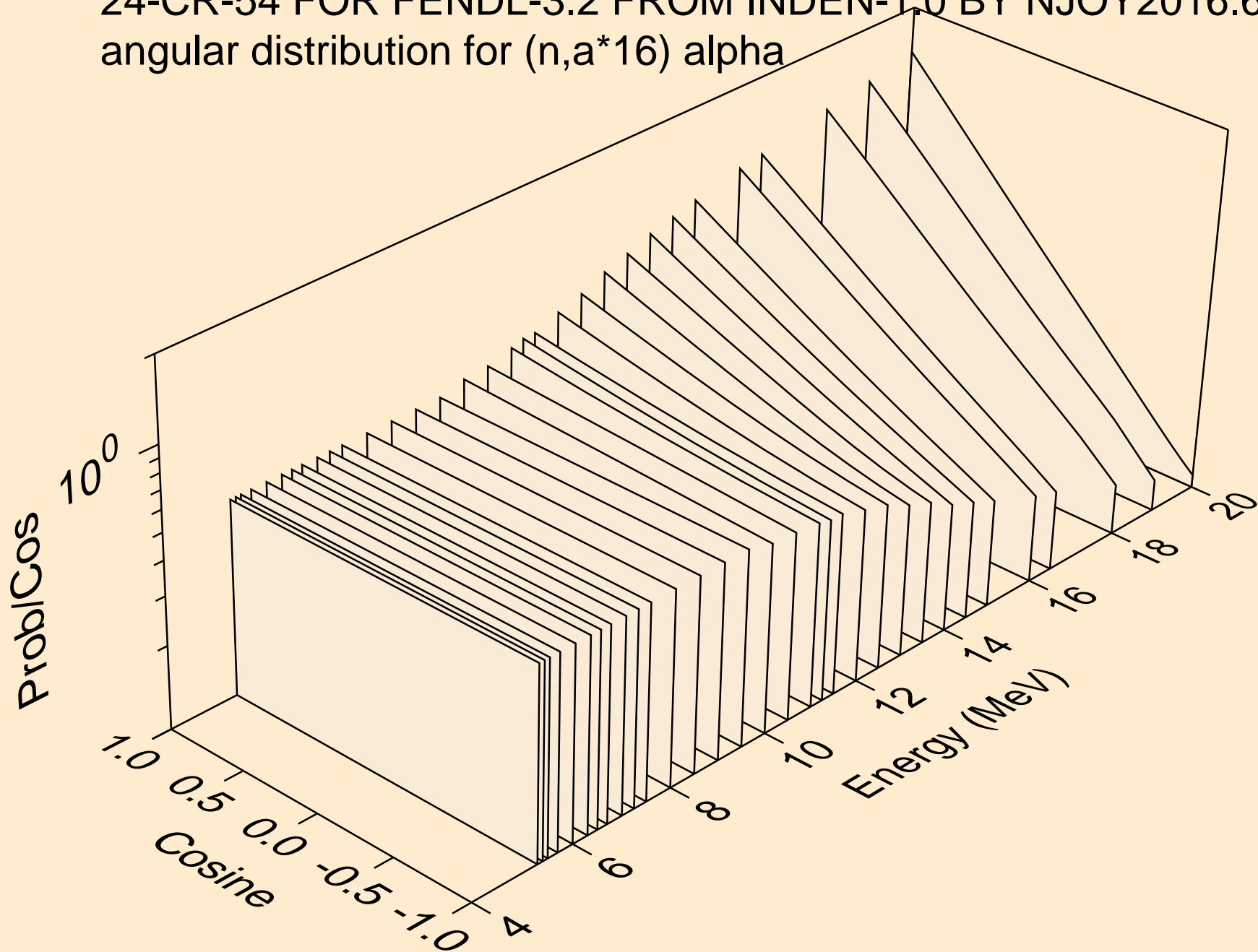

24-CR-54 FOR FENDL-3.2 FROM INDEN-1.0 BY NJOY2016.60+ OI
angular distribution for (n,a*16) alpha

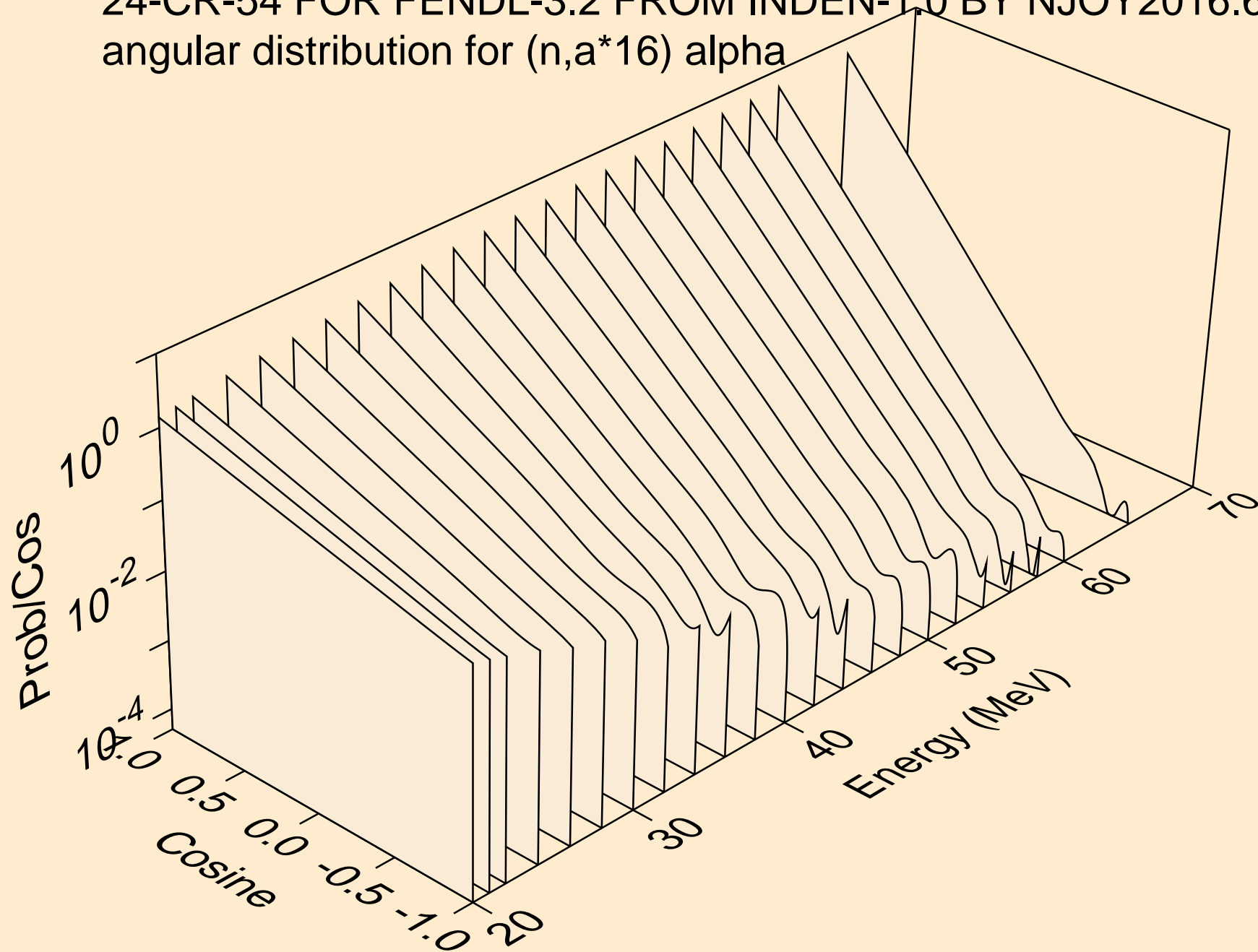

24-CR-54 FOR FENDL-3.2 FROM INDEN-1.0 BY NJOY2016.60+ OI
angular distribution for (n,a*17) alpha

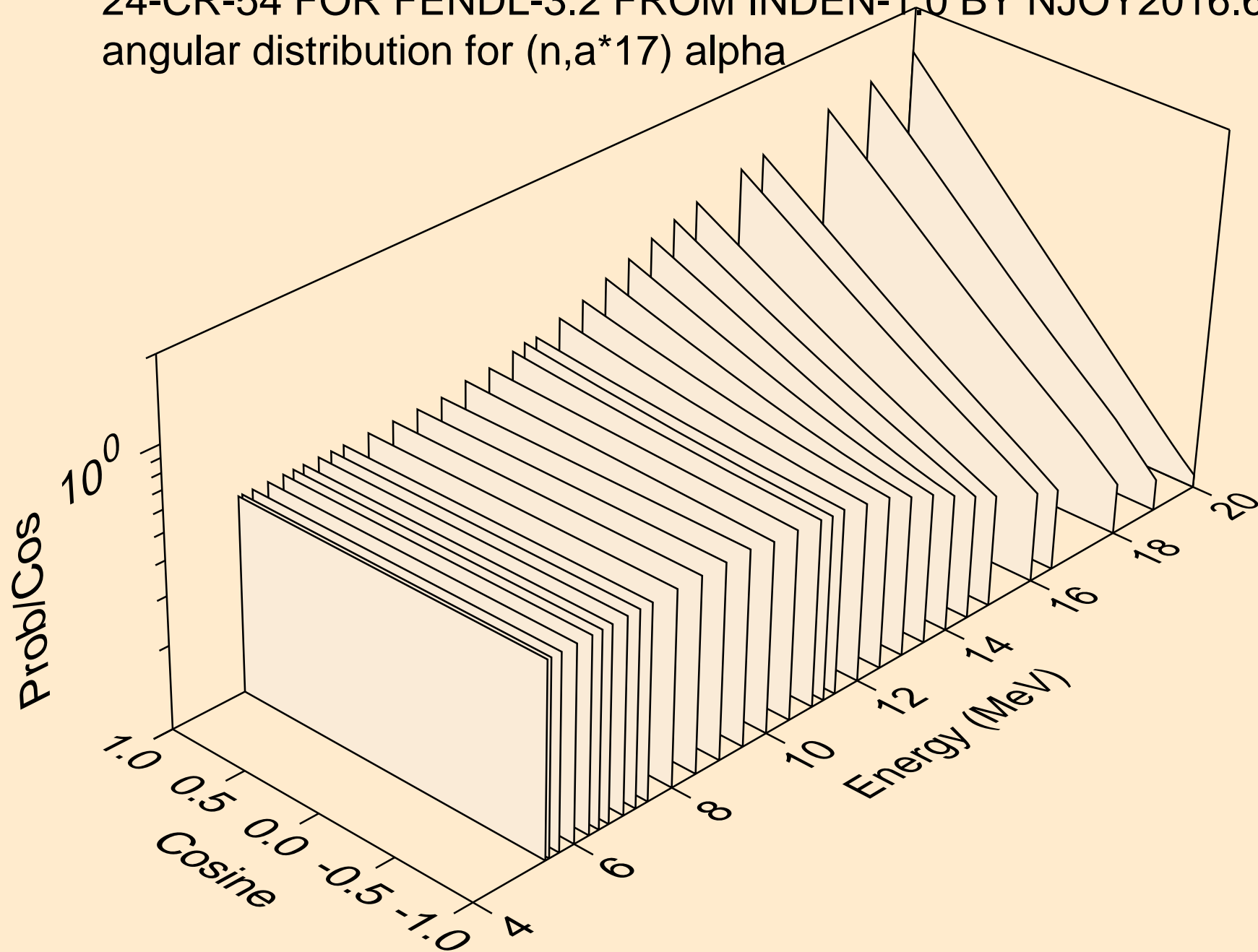

24-CR-54 FOR FENDL-3.2 FROM INDEN-1.0 BY NJOY2016.60+ OI
angular distribution for (n,a*17) alpha

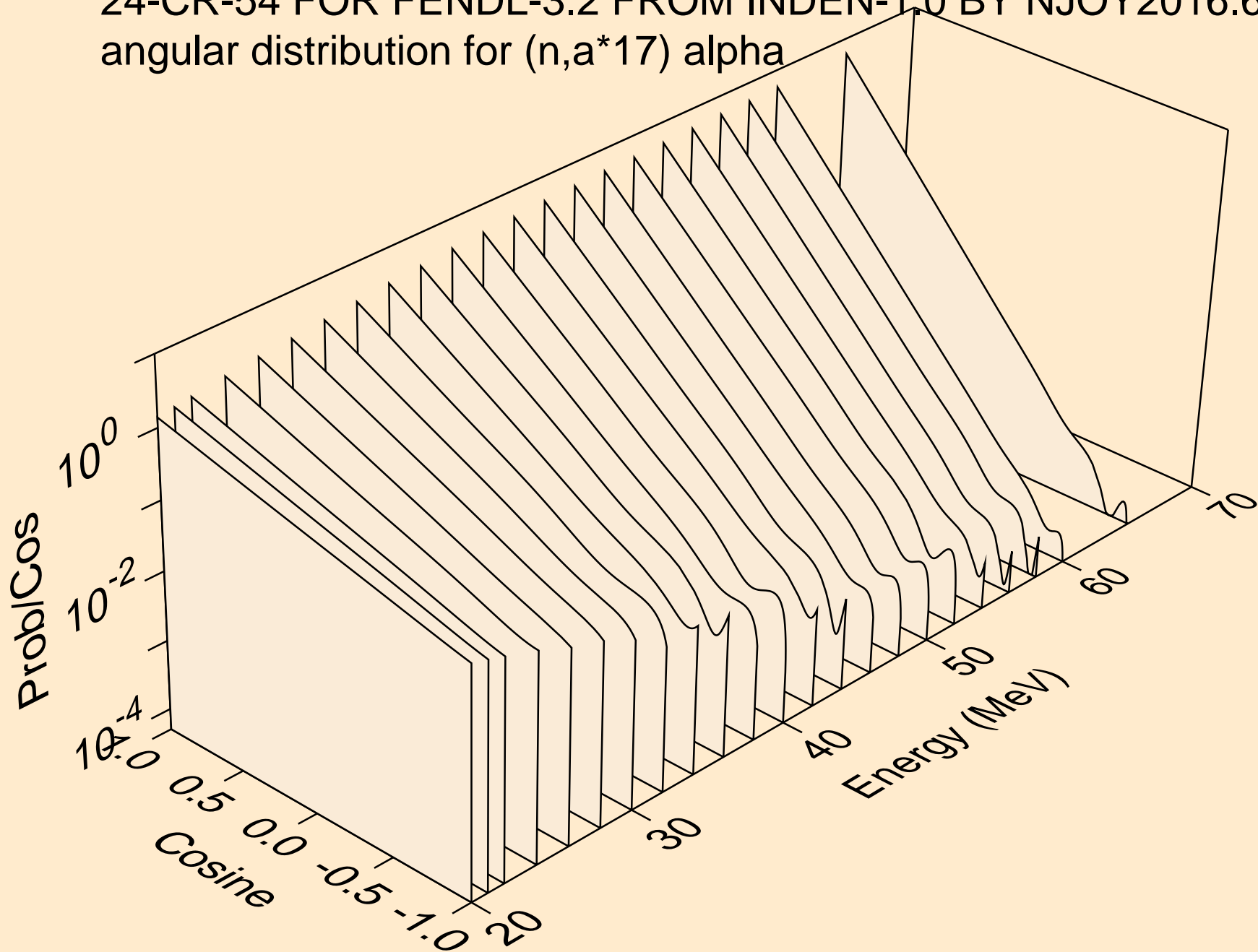

24-CR-54 FOR FENDL-3.2 FROM INDEN-1.0 BY NJOY2016.60+ OI
angular distribution for (n,a*18) alpha

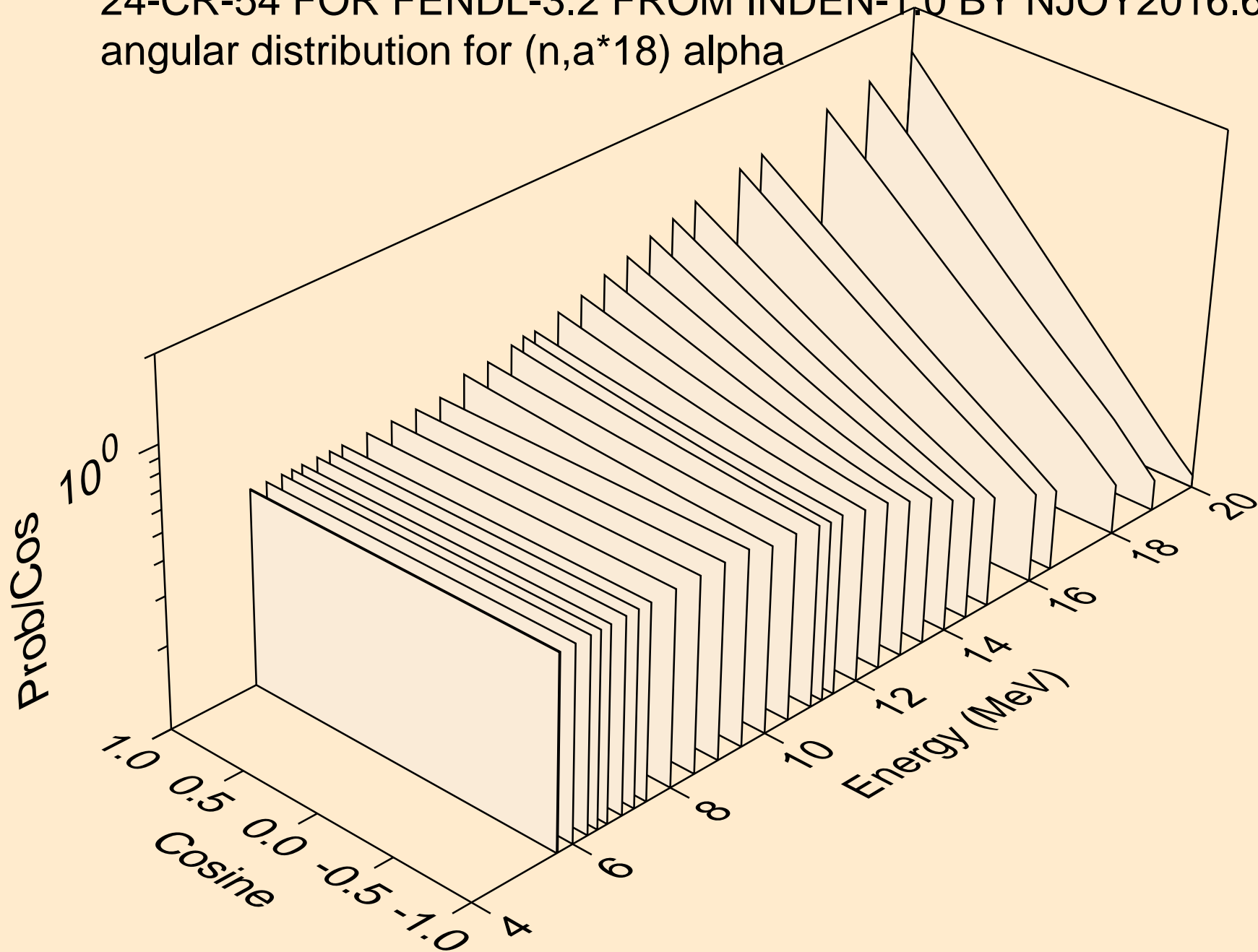

24-CR-54 FOR FENDL-3.2 FROM INDEN-1.0 BY NJOY2016.60+ OI
angular distribution for (n,a*18) alpha

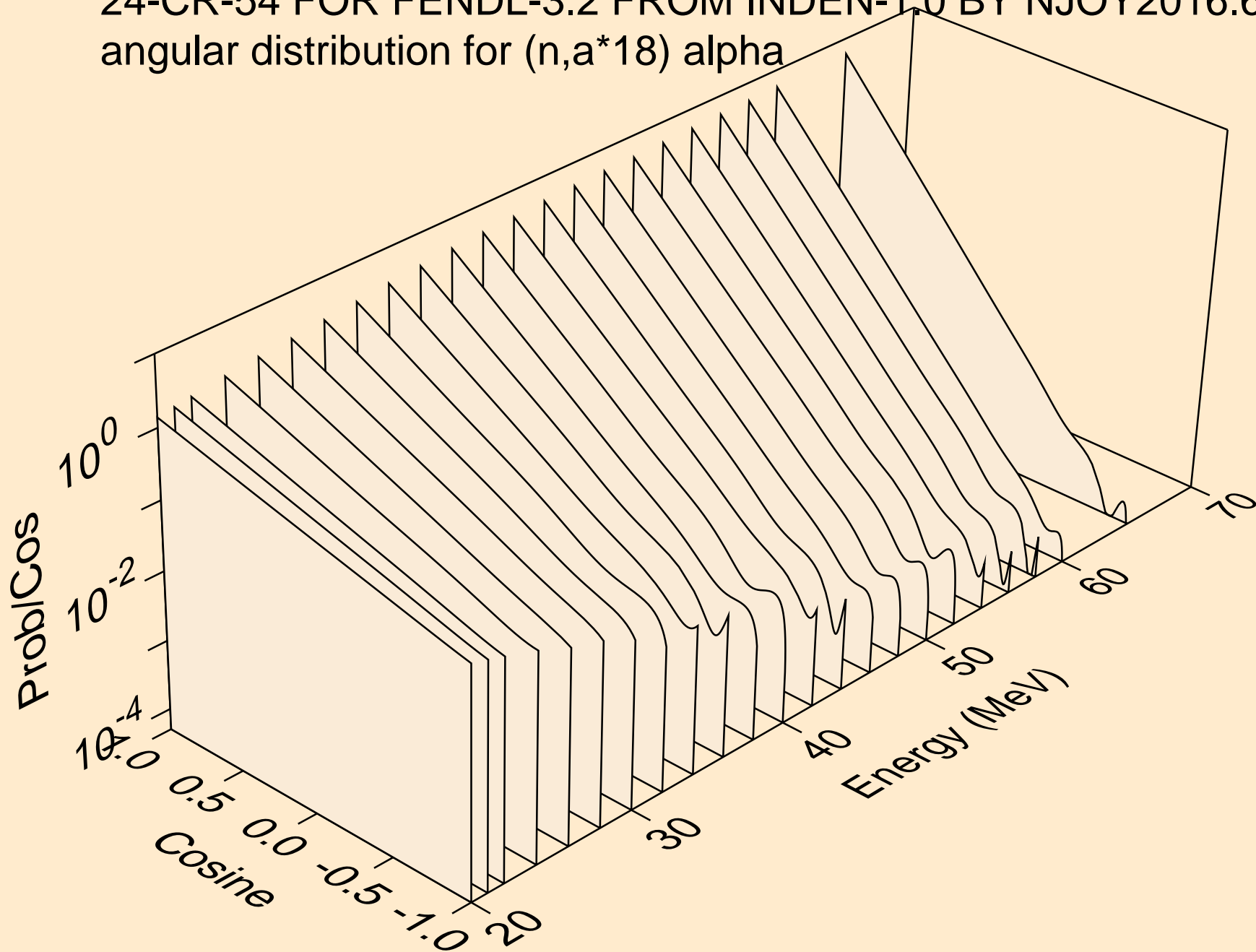

24-CR-54 FOR FENDL-3.2 FROM INDEN-1.0 BY NJOY2016.60+ OI
angular distribution for (n,a*19) alpha

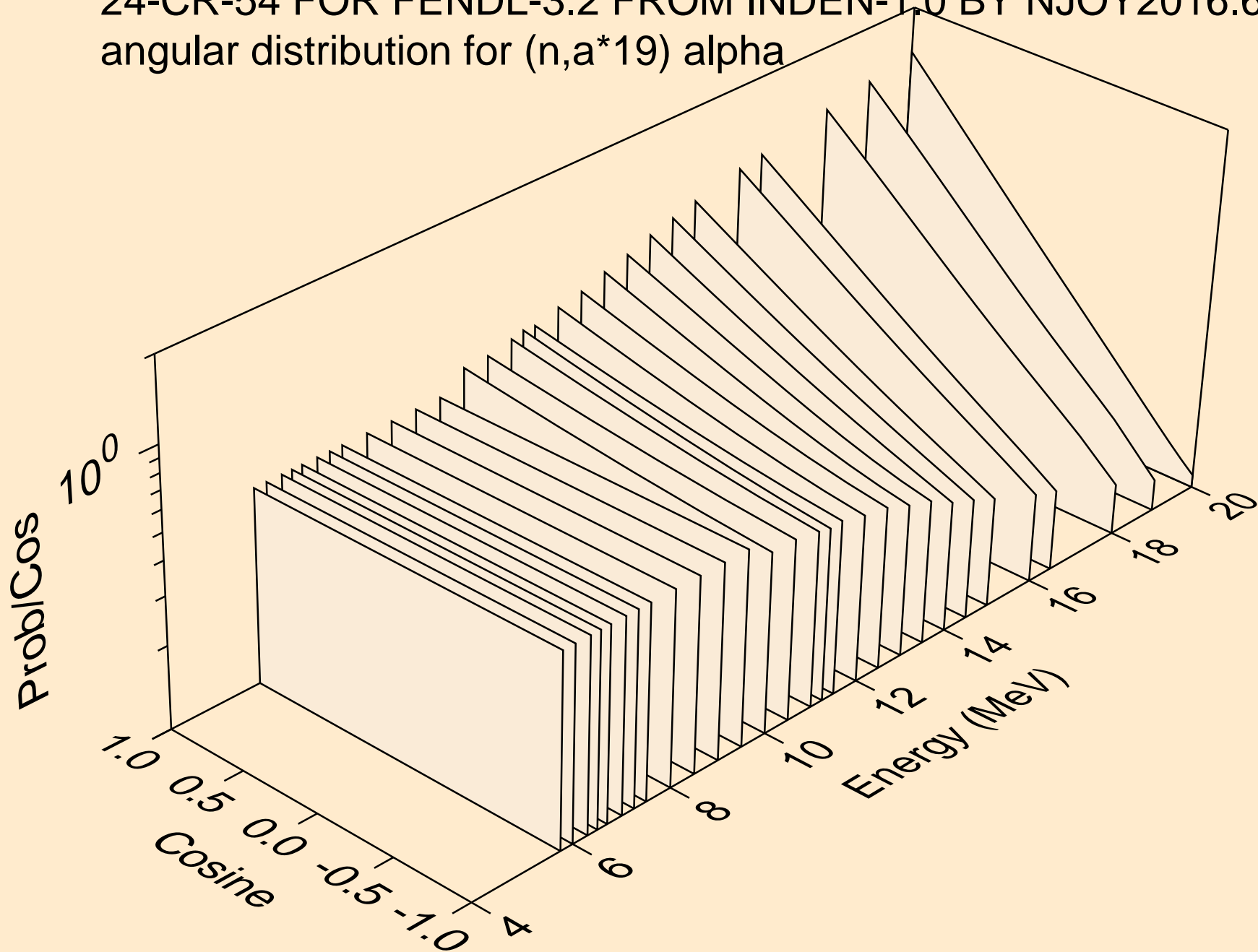

24-CR-54 FOR FENDL-3.2 FROM INDEN-1.0 BY NJOY2016.60+ OI
angular distribution for (n,a*19) alpha

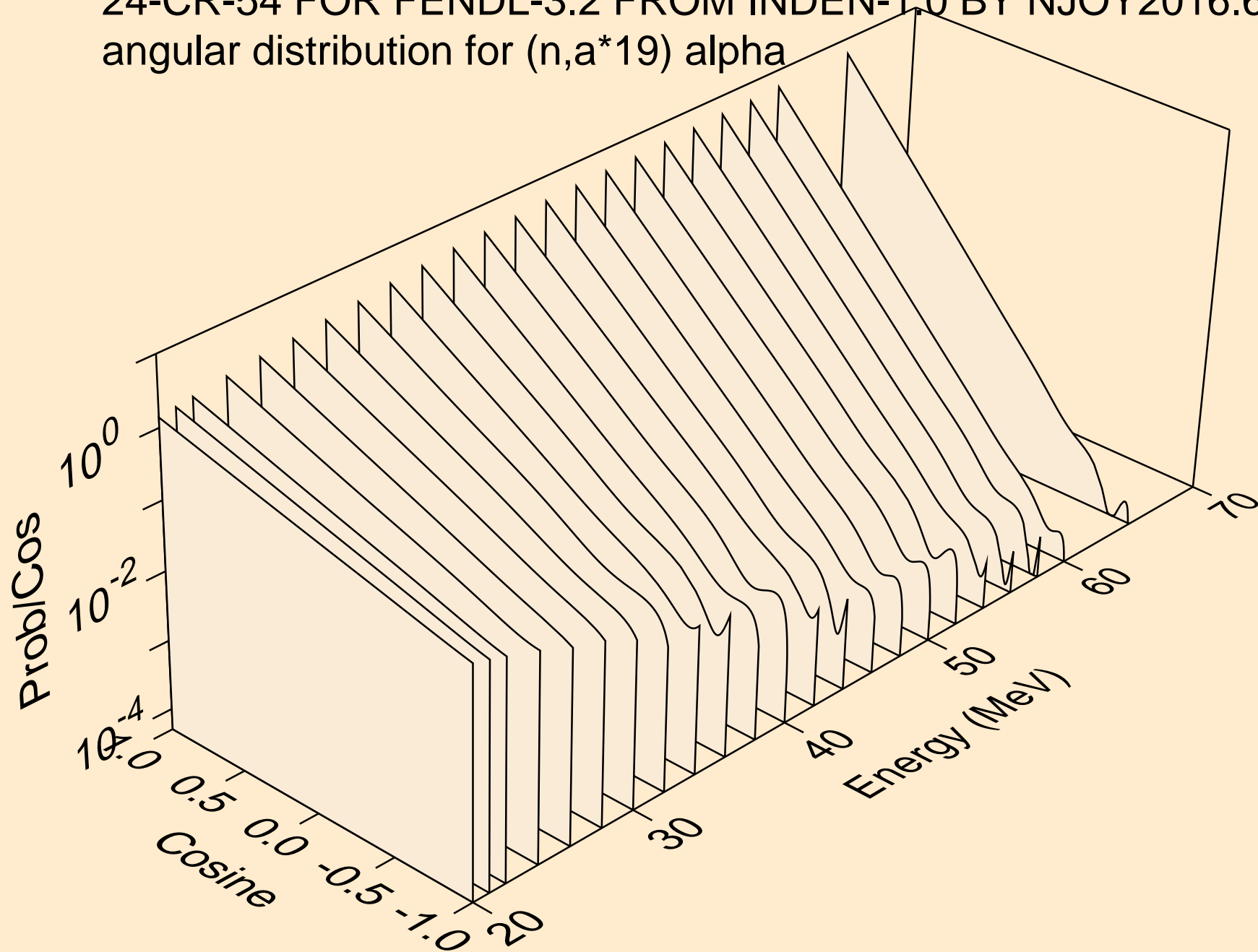

24-CR-54 FOR FENDL-3.2 FROM INDEN-1.0 BY NJOY2016.60+ OI
angular distribution for (n,a*20) alpha

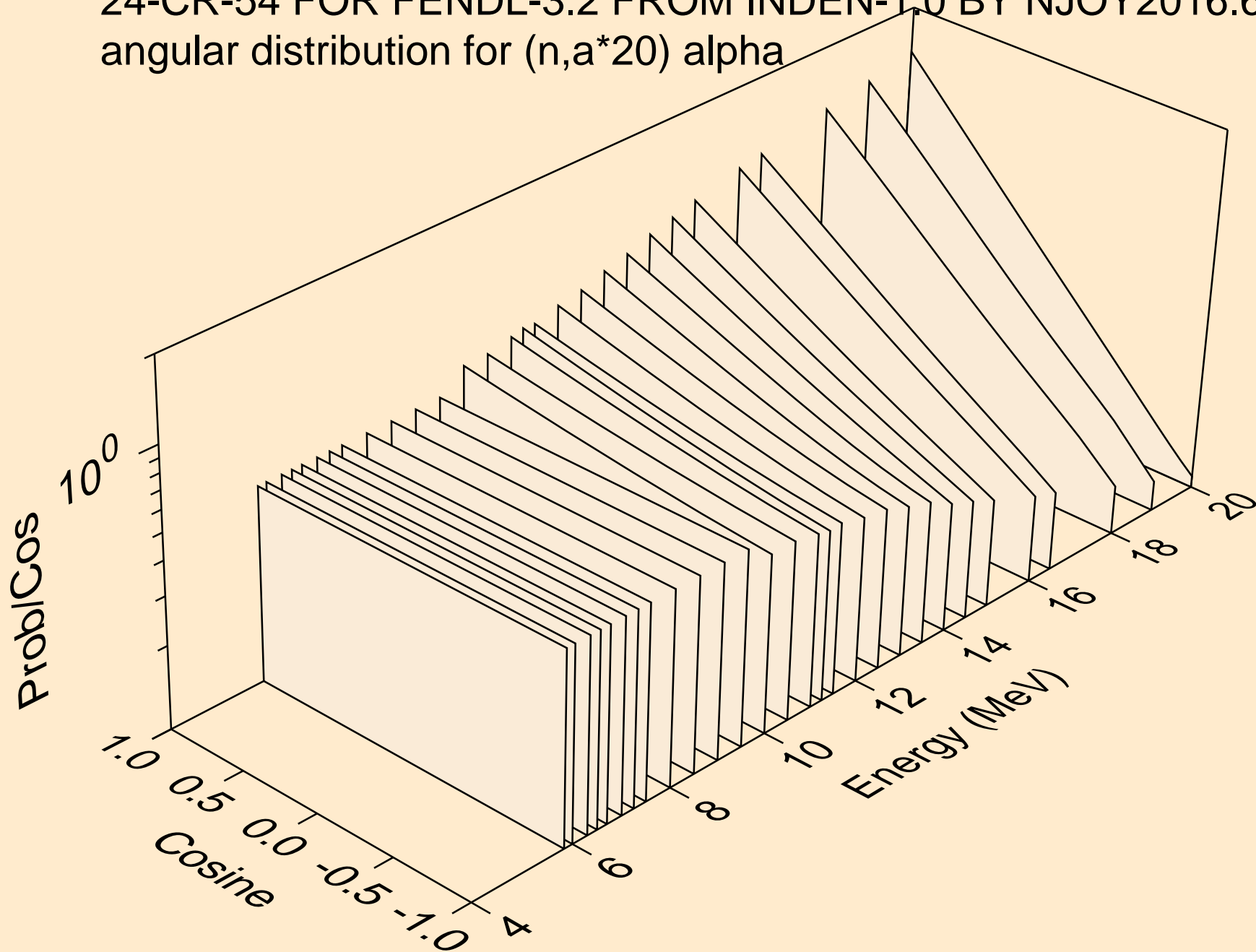

24-CR-54 FOR FENDL-3.2 FROM INDEN-1.0 BY NJOY2016.60+ OI
angular distribution for (n,a*20) alpha

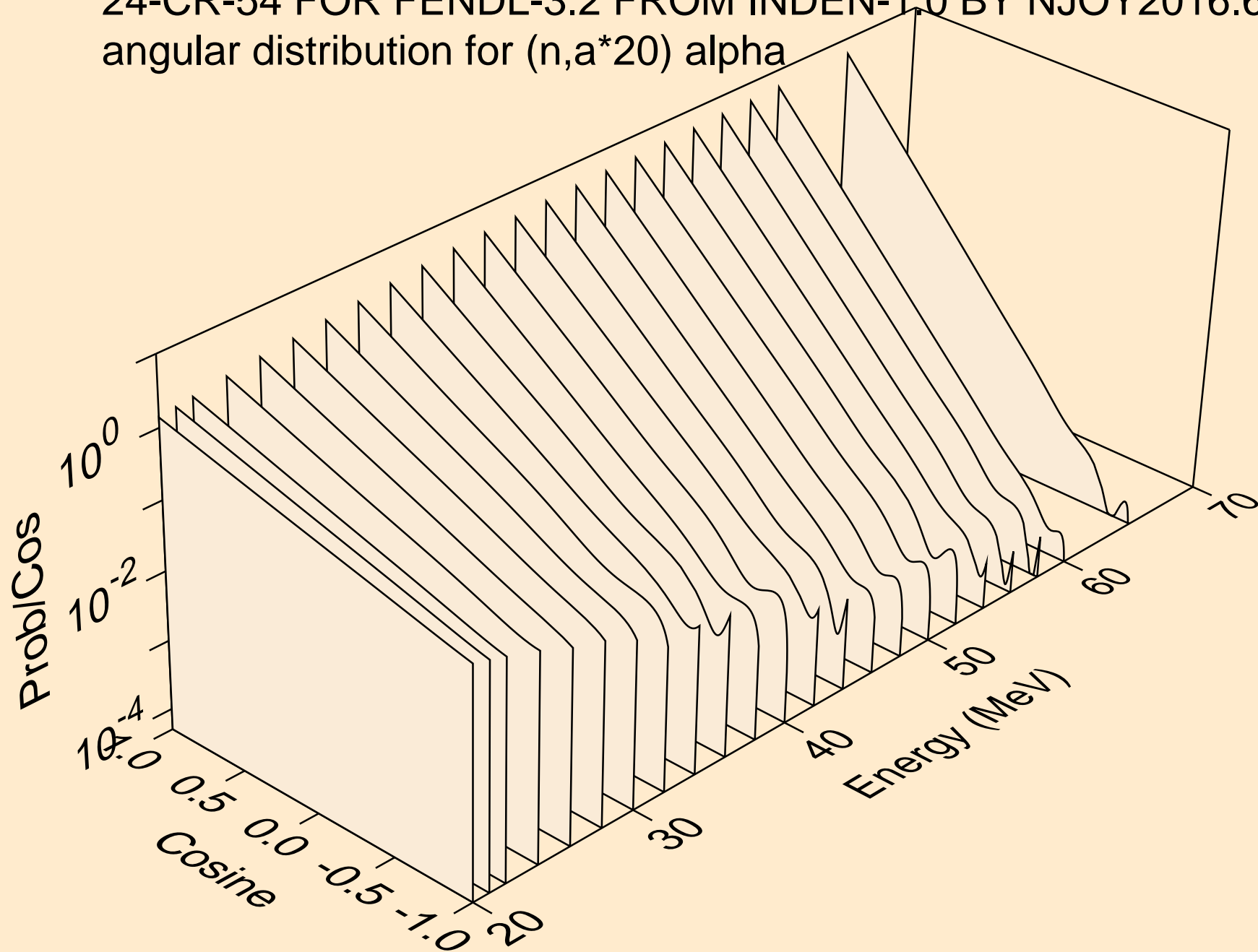

24-CR-54 FOR FENDL-3.2 FROM INDEN-1.0 BY NJOY2016.60+ OI
angular distribution for (n,a*21) alpha

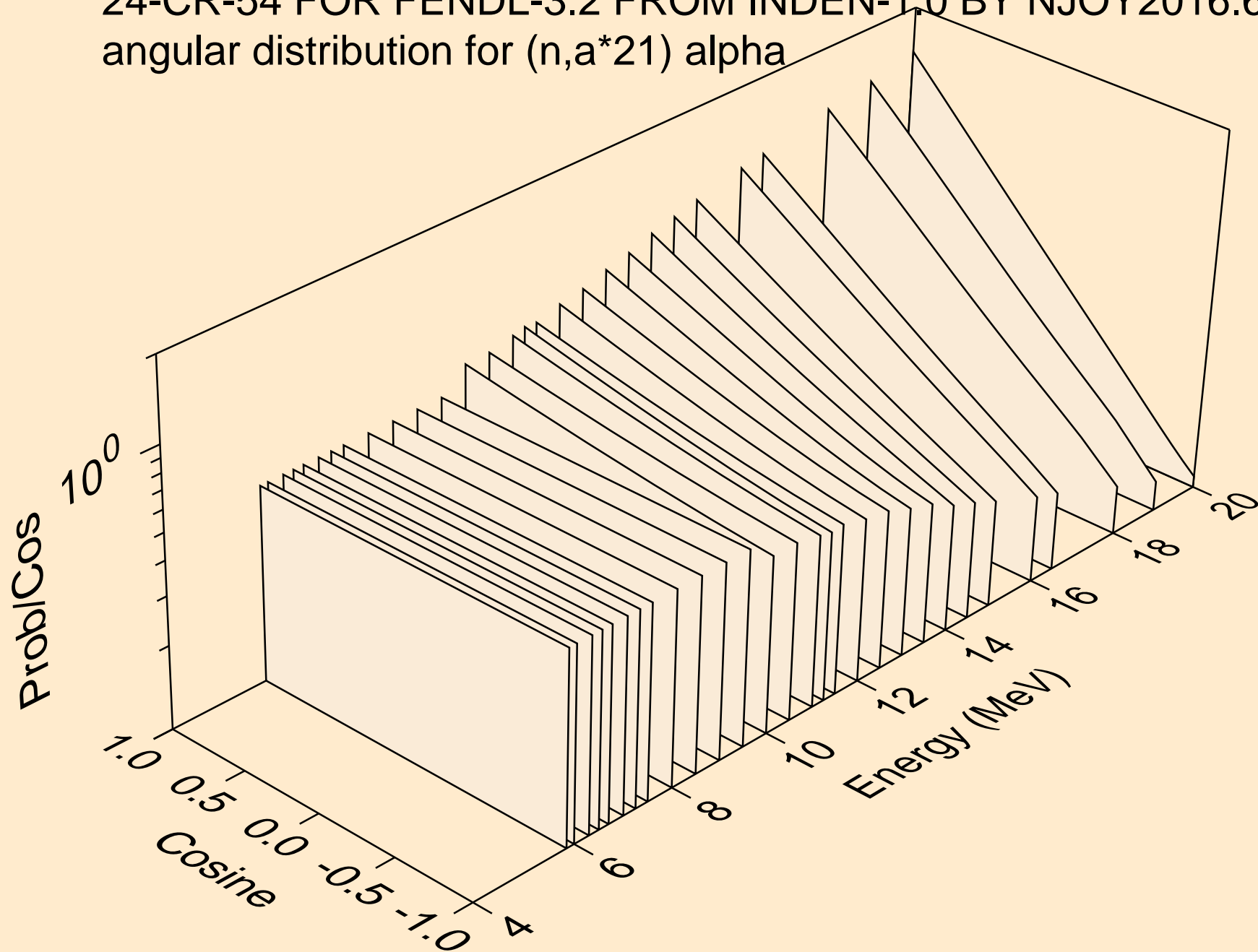

24-CR-54 FOR FENDL-3.2 FROM INDEN-1.0 BY NJOY2016.60+ OI
angular distribution for (n,a*21) alpha

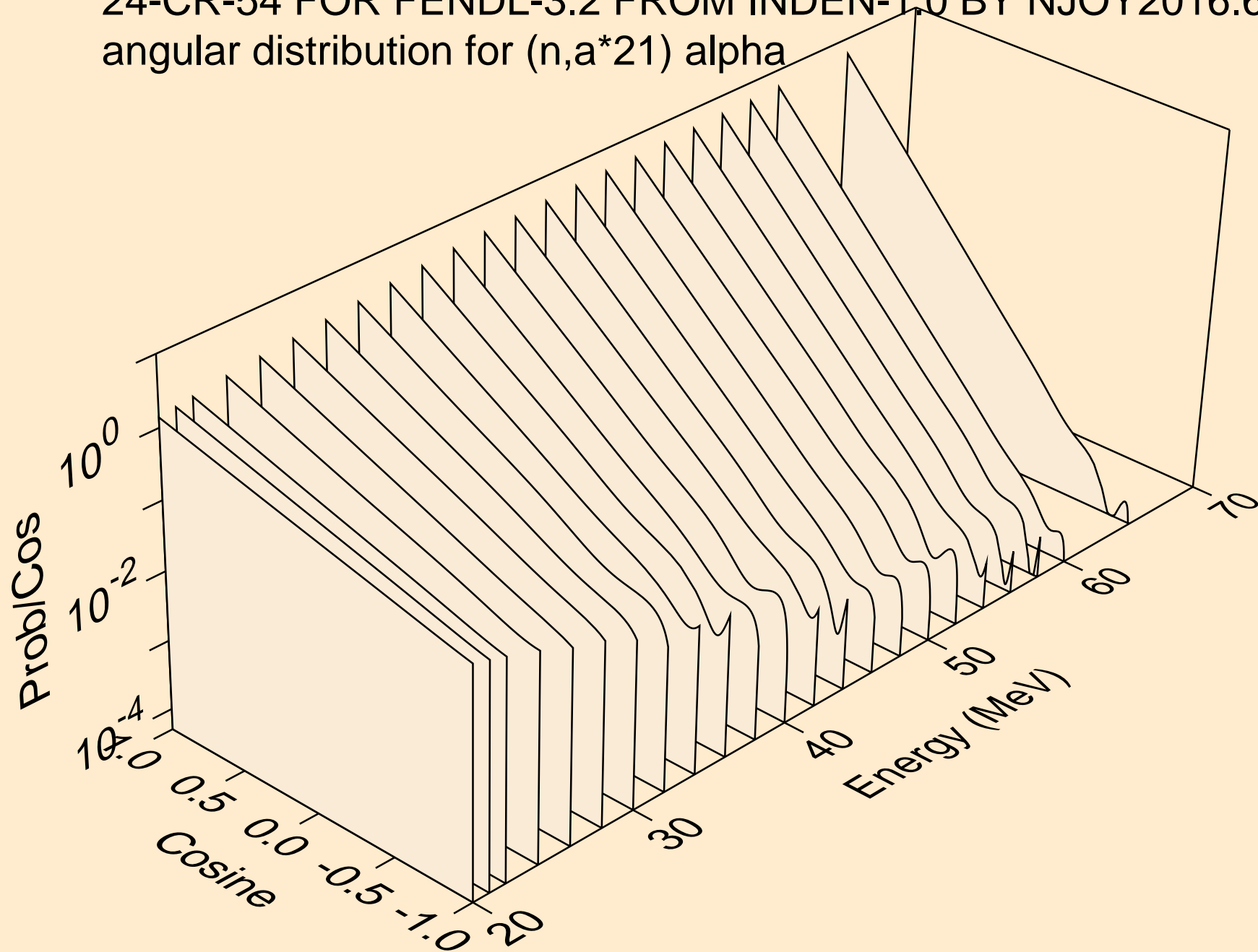

24-CR-54 FOR FENDL-3.2 FROM INDEN-1.0 BY NJOY2016.60+ OI
angular distribution for (n, α *22) alpha

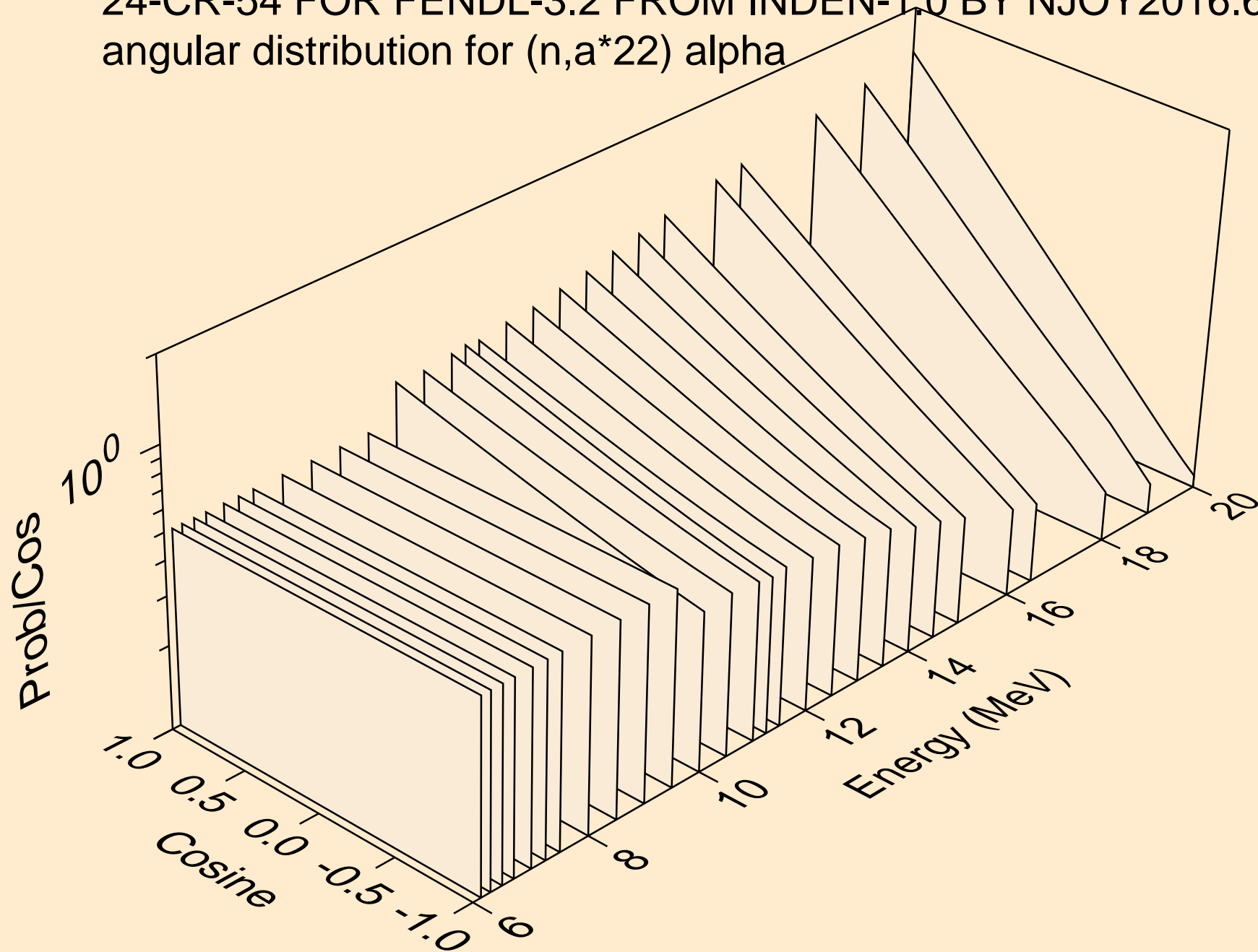

24-CR-54 FOR FENDL-3.2 FROM INDEN-1.0 BY NJOY2016.60+ OI
angular distribution for (n, α *22) alpha

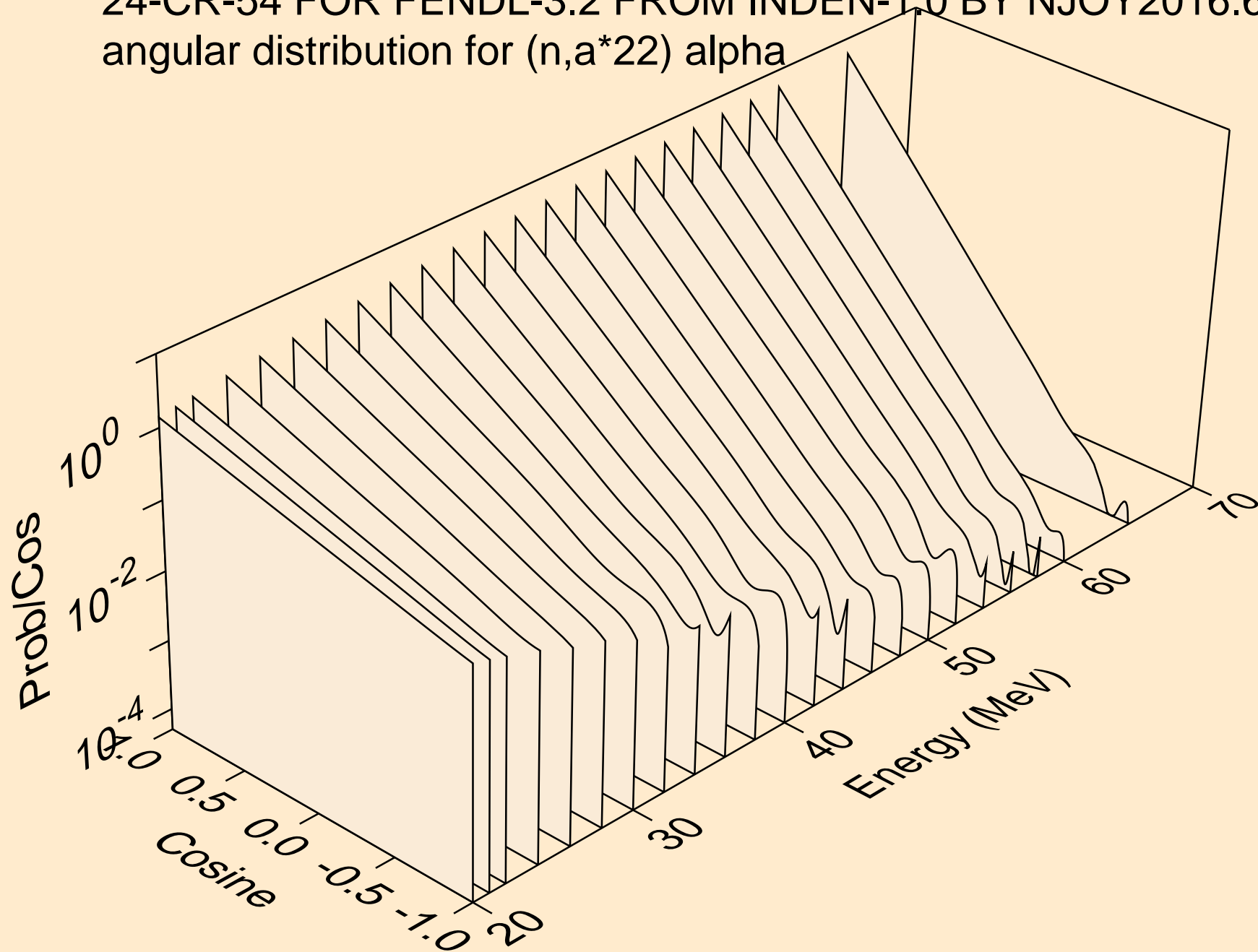

24-CR-54 FOR FENDL-3.2 FROM INDEN-1.0 BY NJOY2016.60+ OI
angular distribution for (n, α *23) alpha

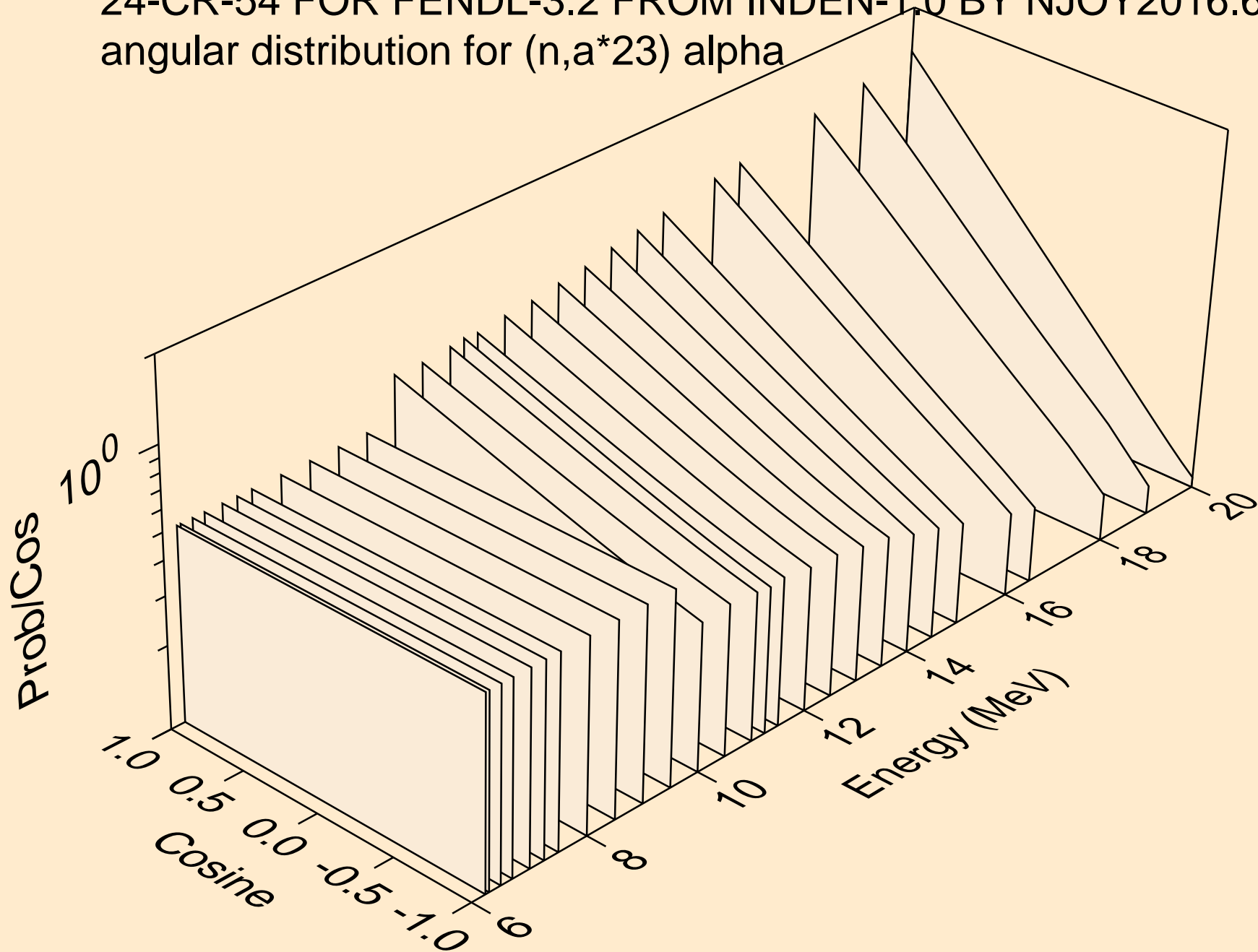

24-CR-54 FOR FENDL-3.2 FROM INDEN-1.0 BY NJOY2016.60+ OI
angular distribution for (n, α *23) alpha

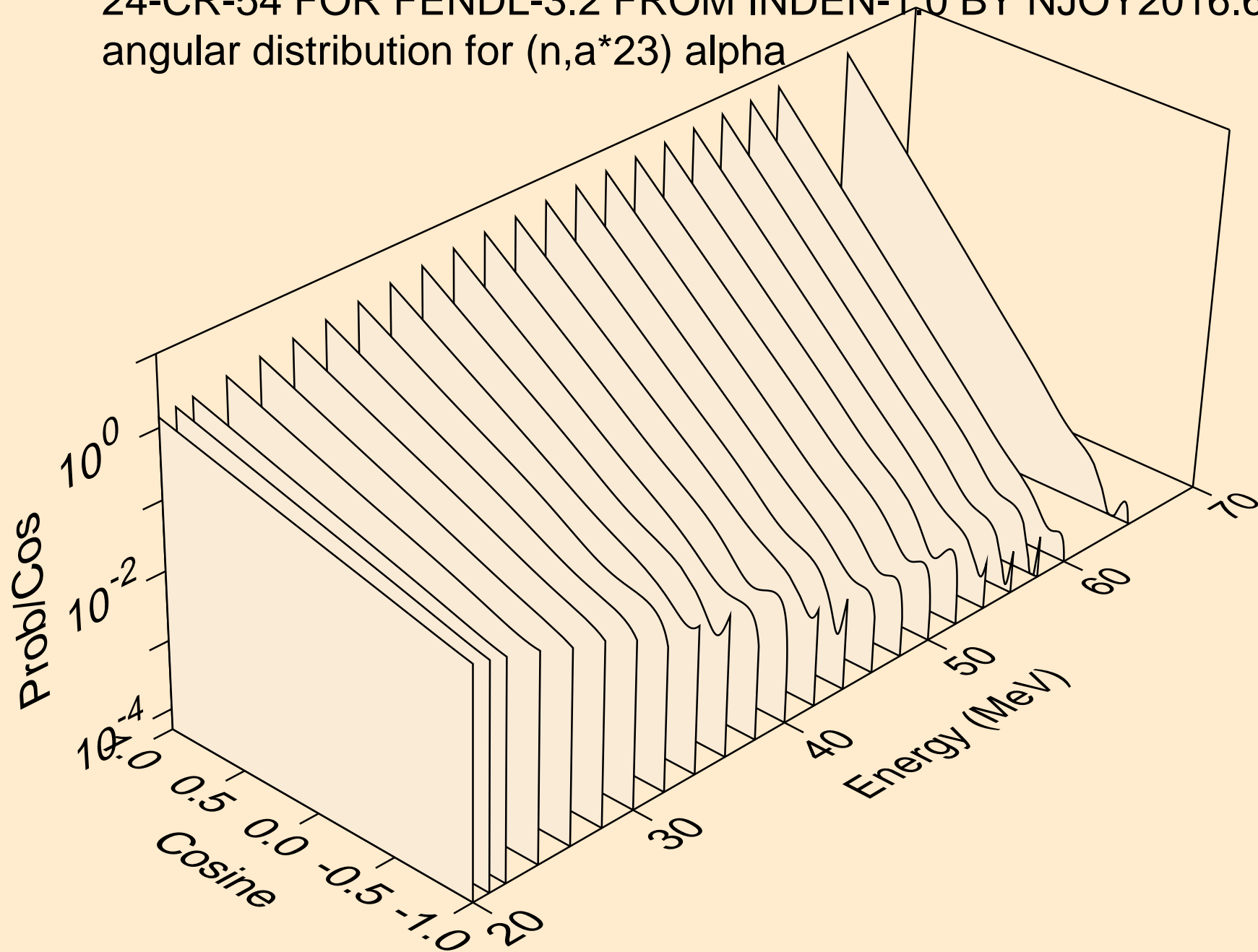

24-CR-54 FOR FENDL-3.2 FROM INDEN-1.0 BY NJOY2016.60+ OI
angular distribution for (n,a*24) alpha

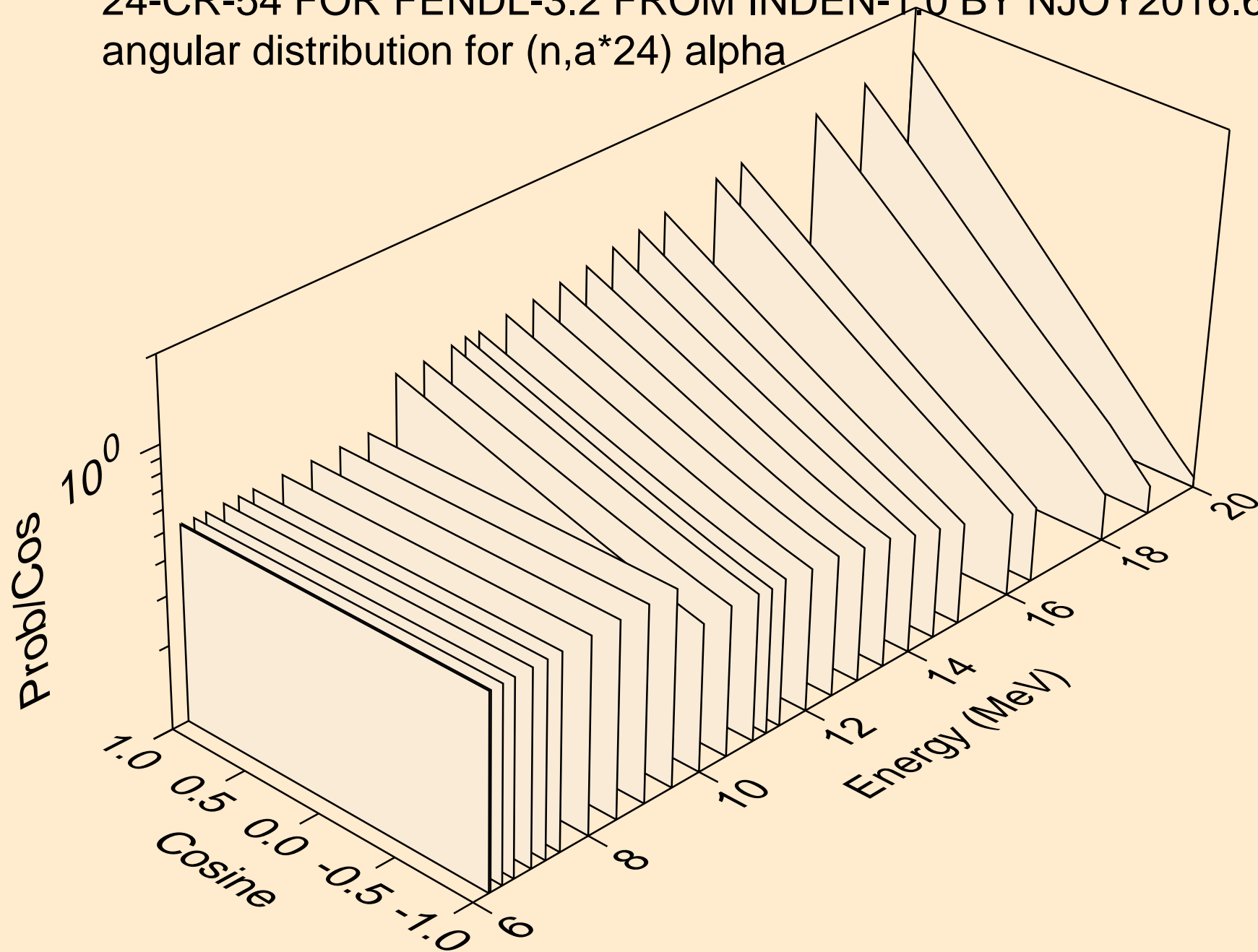

24-CR-54 FOR FENDL-3.2 FROM INDEN-1.0 BY NJOY2016.60+ OI
angular distribution for (n,a*24) alpha

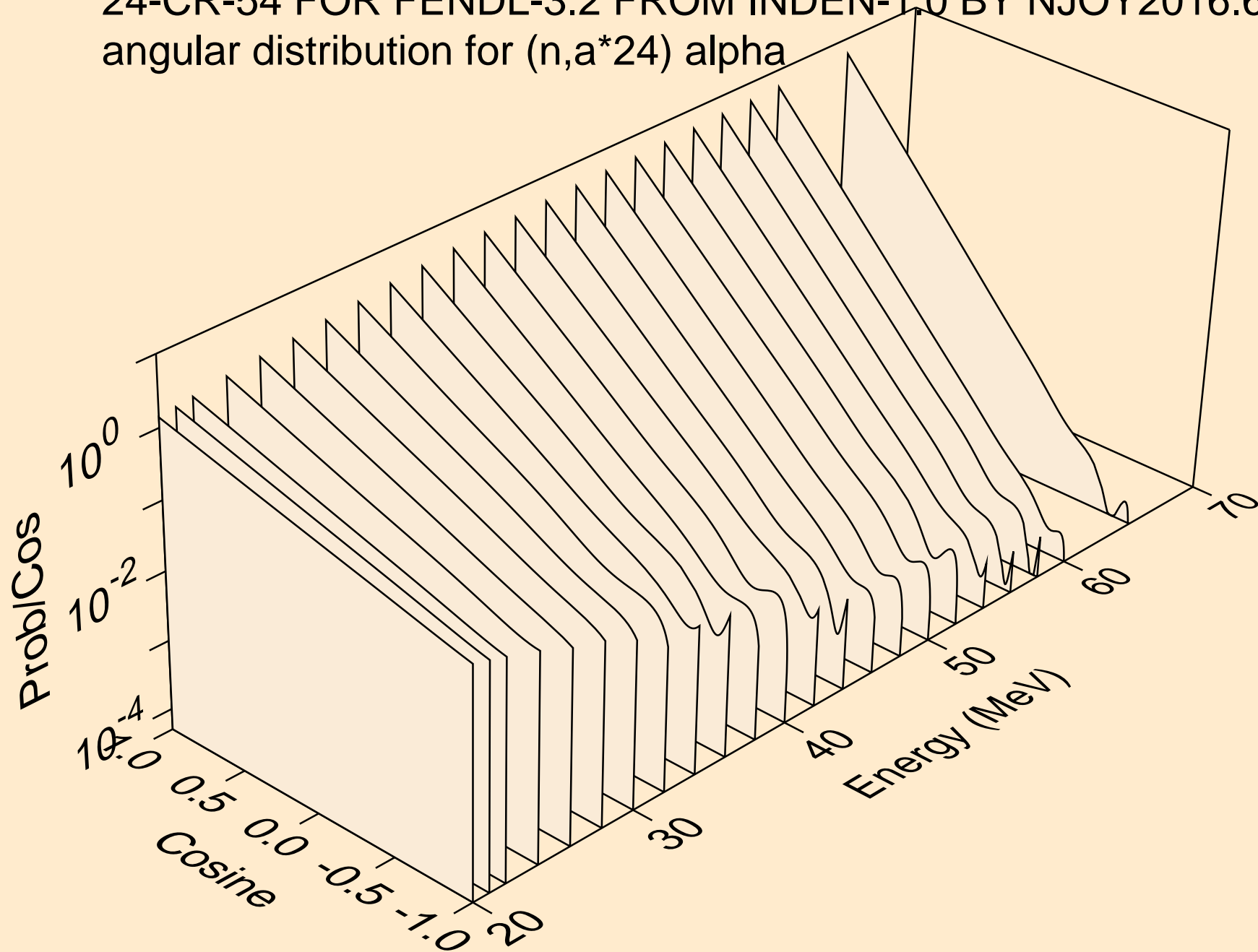

24-CR-54 FOR FENDL-3.2 FROM INDEN-1.0 BY NJOY2016.60+ OI
angular distribution for (n,a*25) alpha

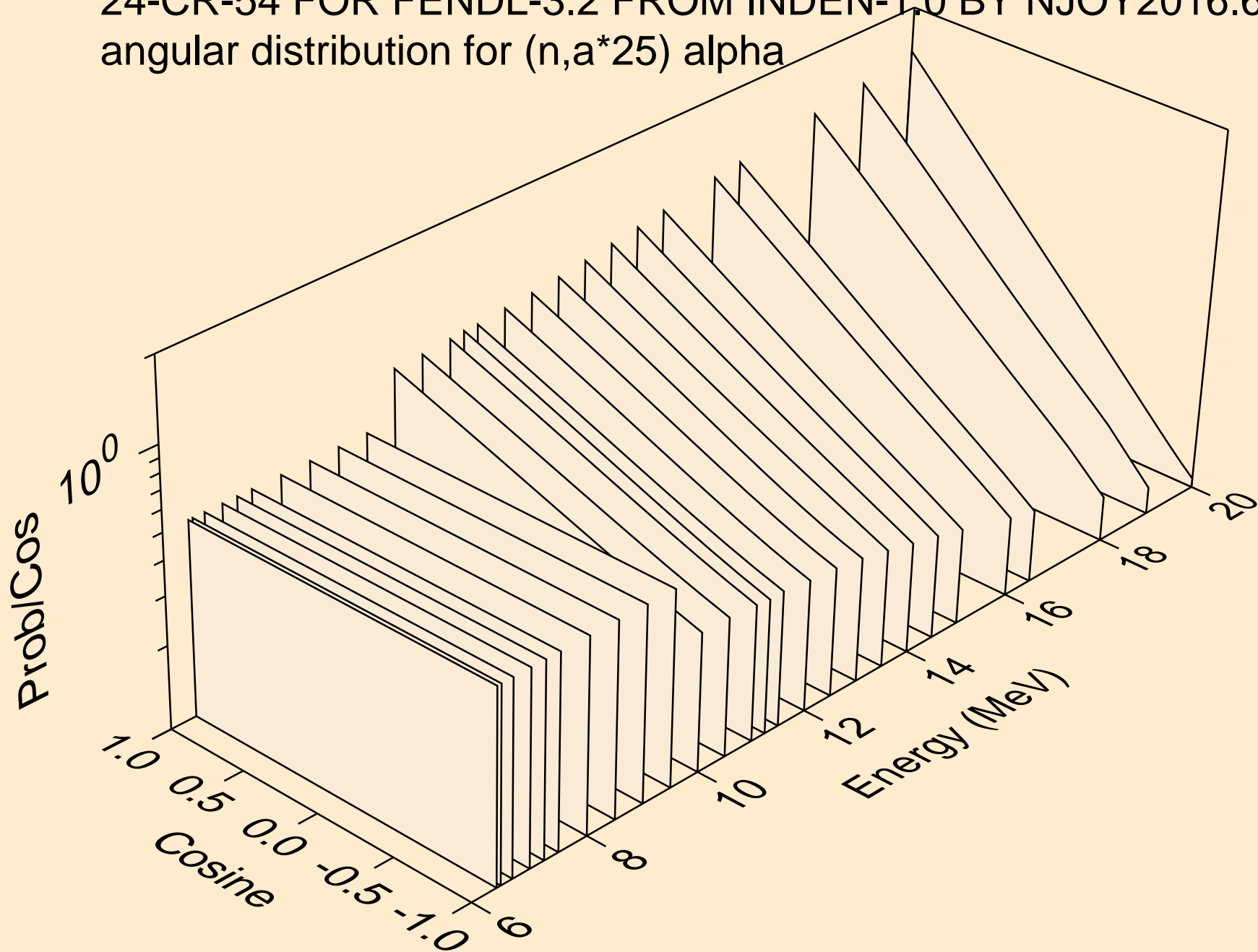

24-CR-54 FOR FENDL-3.2 FROM INDEN-1.0 BY NJOY2016.60+ OI
angular distribution for (n,a*25) alpha

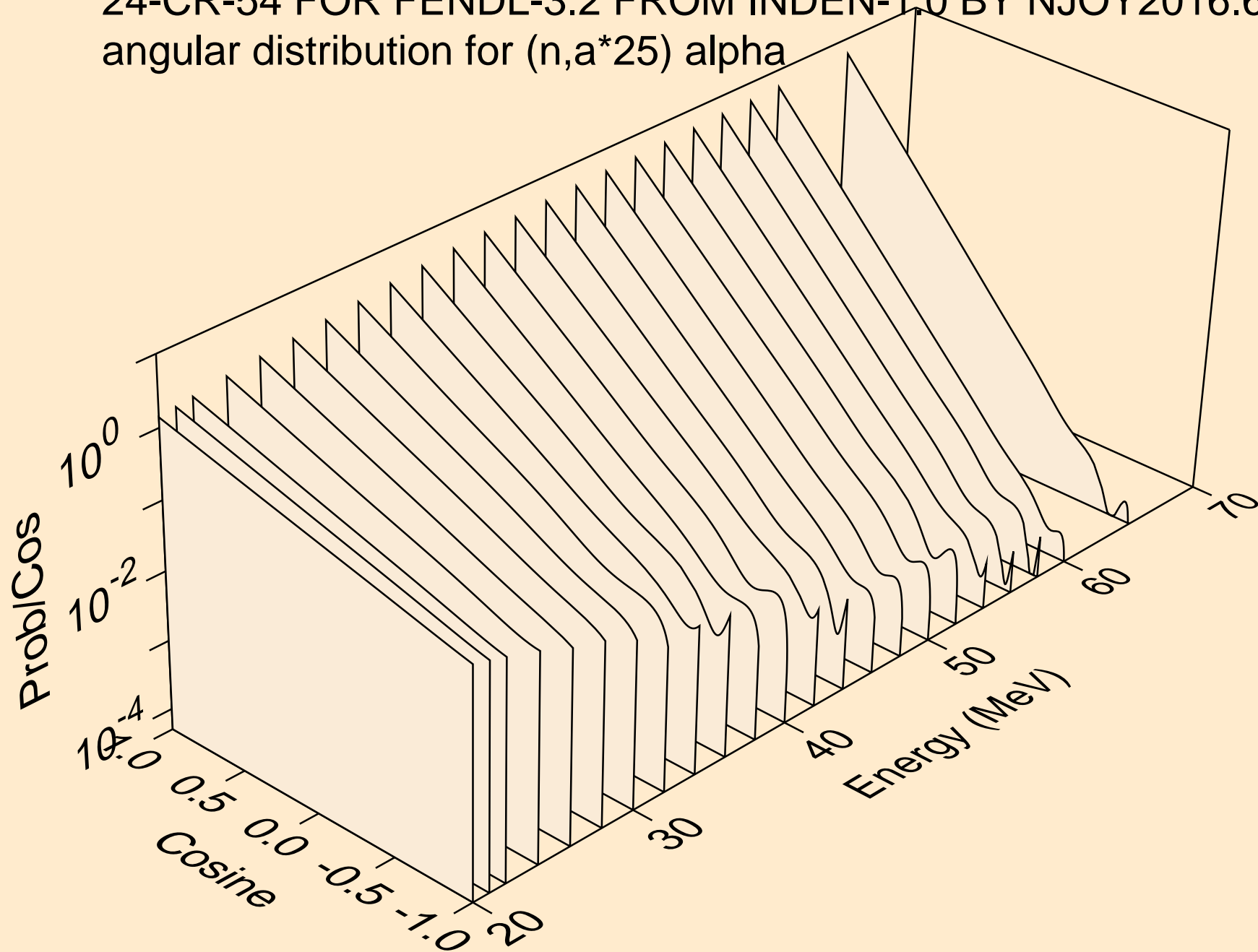

24-CR-54 FOR FENDL-3.2 FROM INDEN-1.0 BY NJOY2016.60+ OI
angular distribution for (n,a*26) alpha

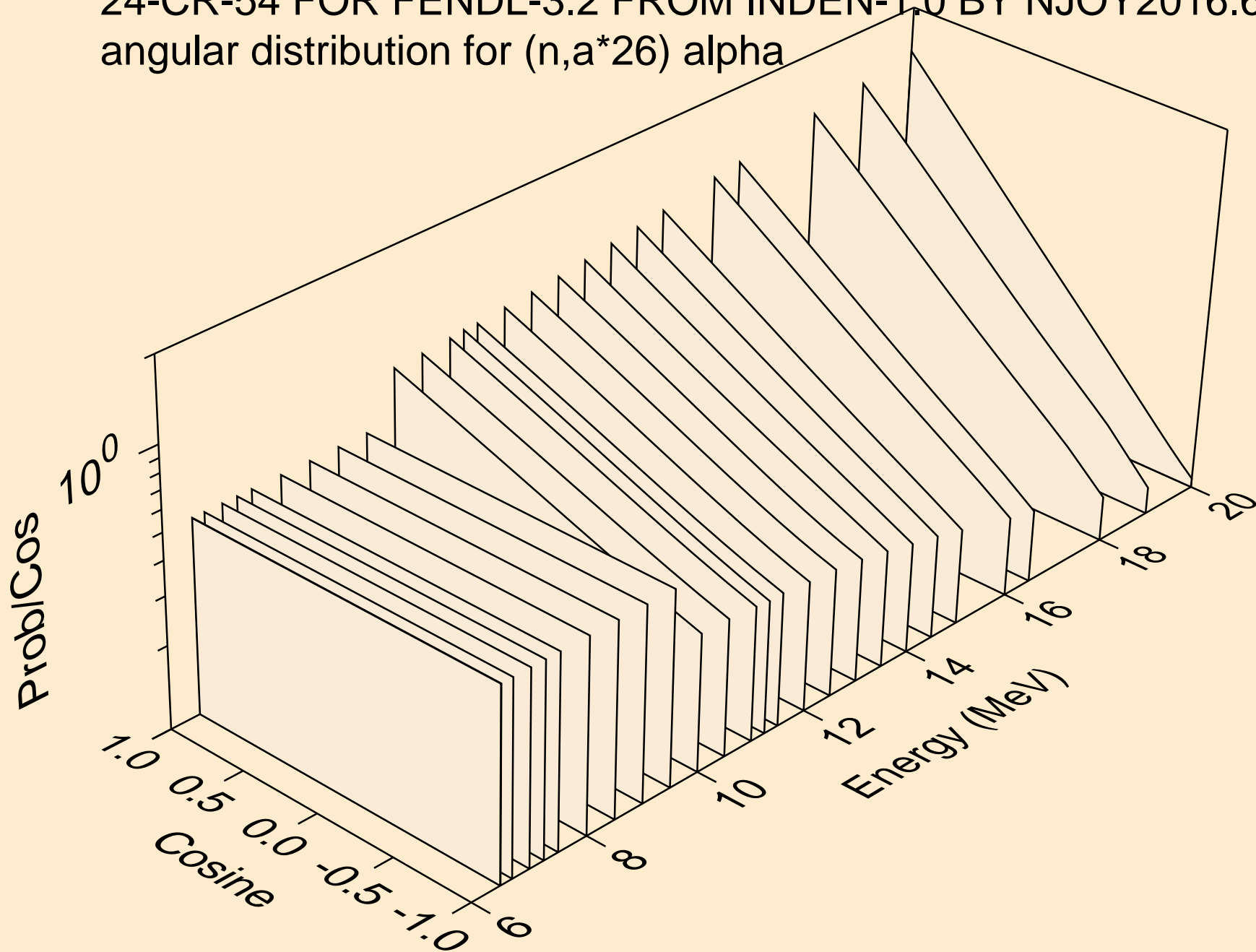

24-CR-54 FOR FENDL-3.2 FROM INDEN-1.0 BY NJOY2016.60+ OI
angular distribution for (n,a*26) alpha

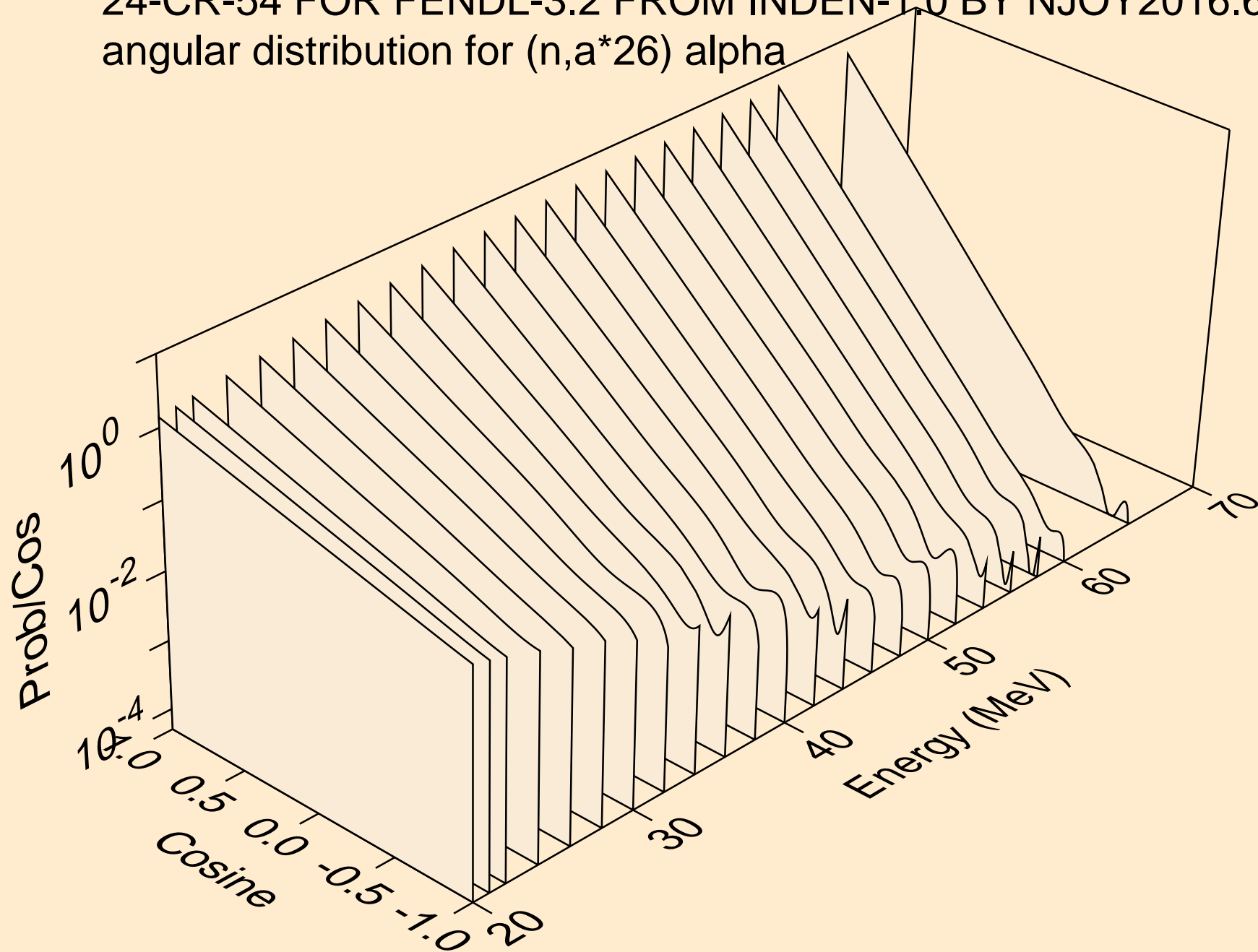

24-CR-54 FOR FENDL-3.2 FROM INDEN-1.0 BY NJOY2016.60+ OI
angular distribution for (n,a*27) alpha

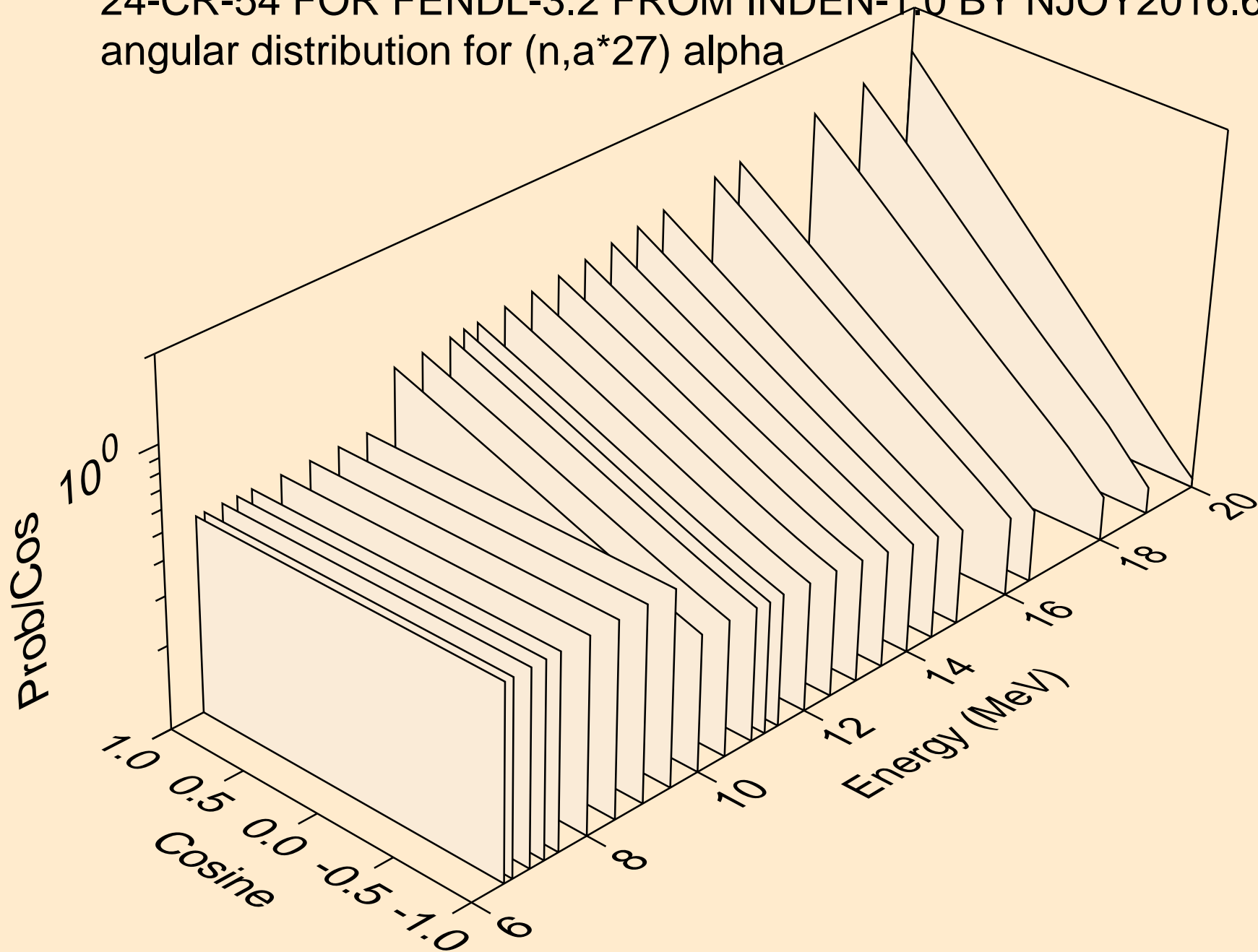

24-CR-54 FOR FENDL-3.2 FROM INDEN-1.0 BY NJOY2016.60+ OI
angular distribution for (n,a*27) alpha

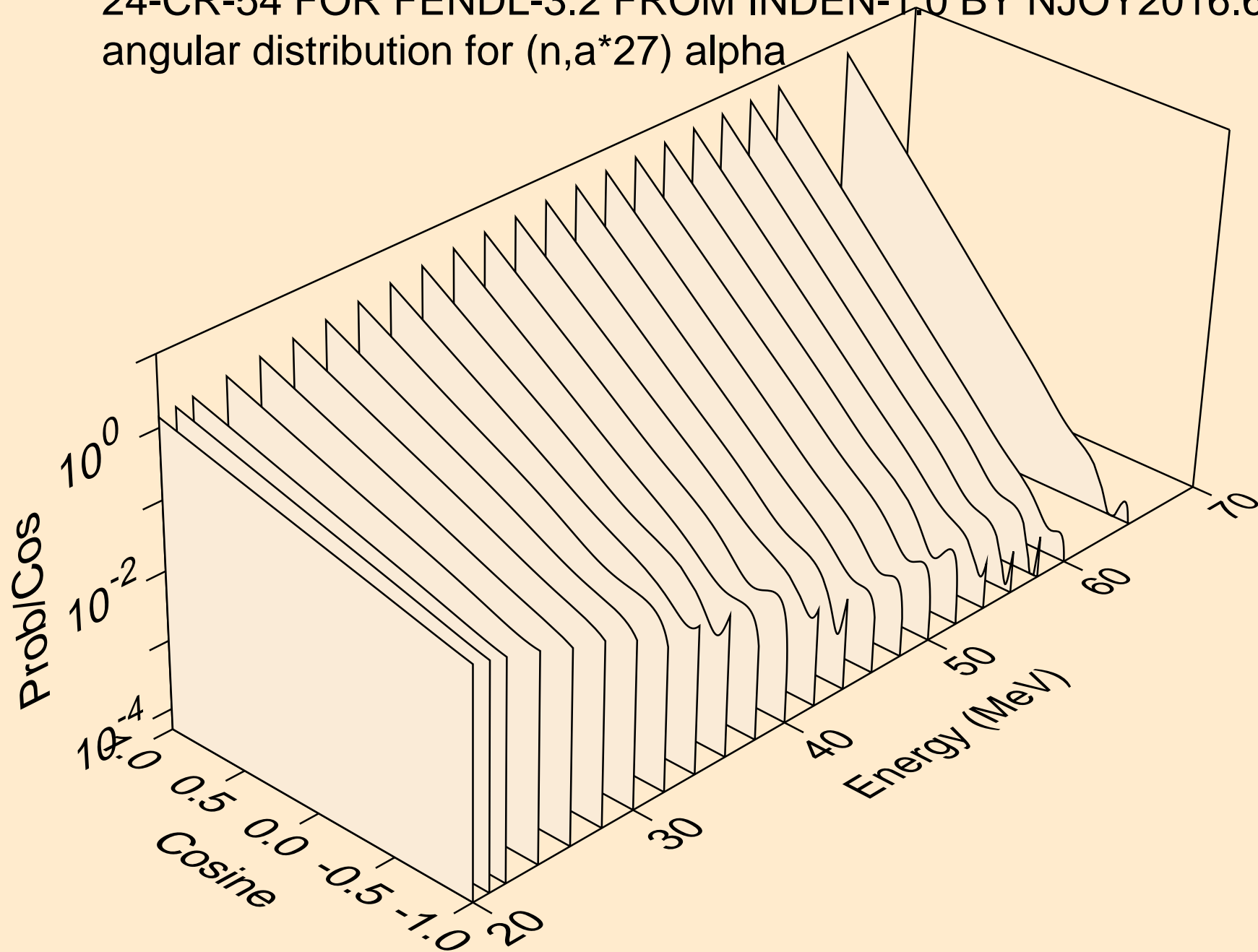

24-CR-54 FOR FENDL-3.2 FROM INDEN-1.0 BY NJOY2016.60+ OI
angular distribution for (n,a*28) alpha

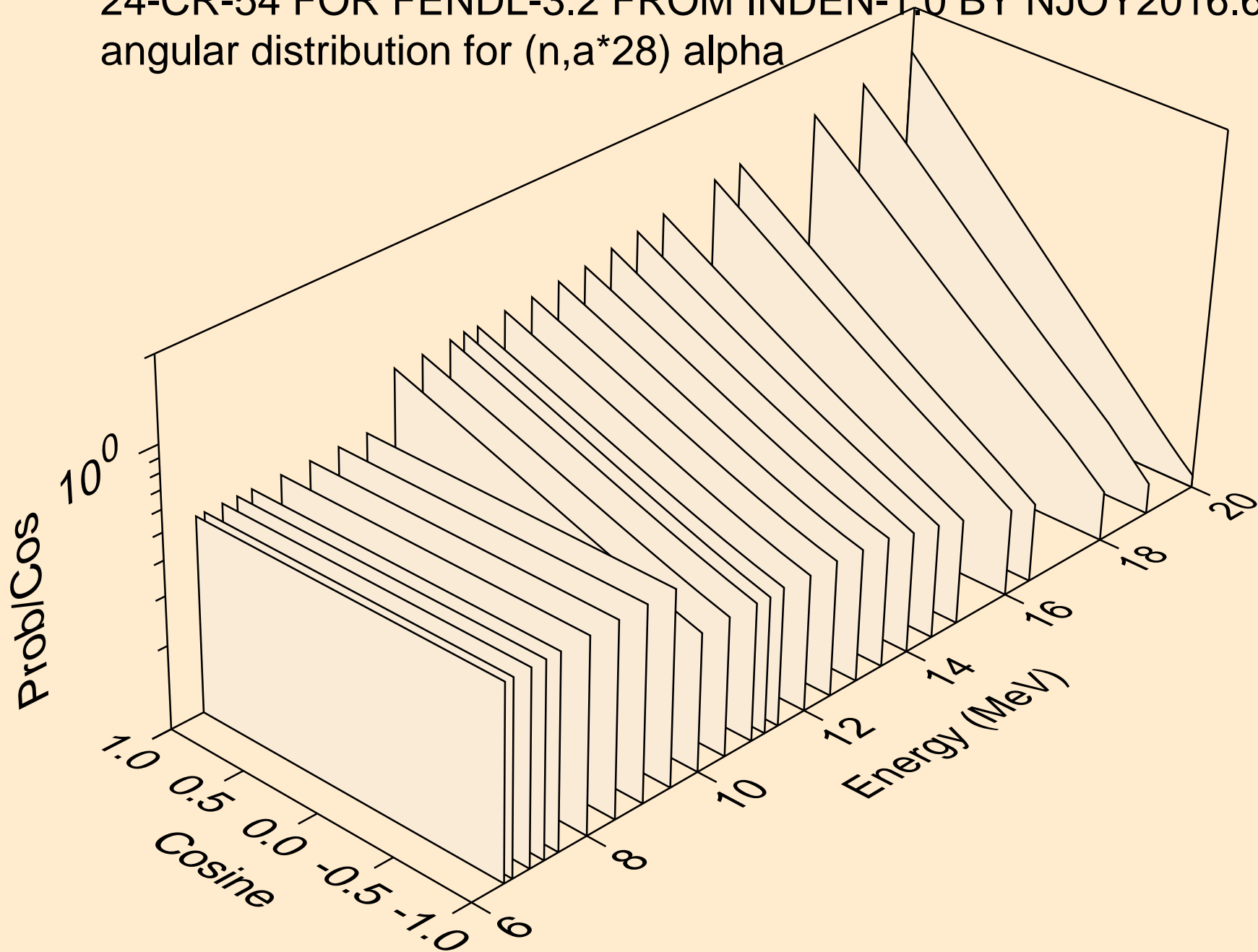

24-CR-54 FOR FENDL-3.2 FROM INDEN-1.0 BY NJOY2016.60+ OI
angular distribution for (n,a*28) alpha

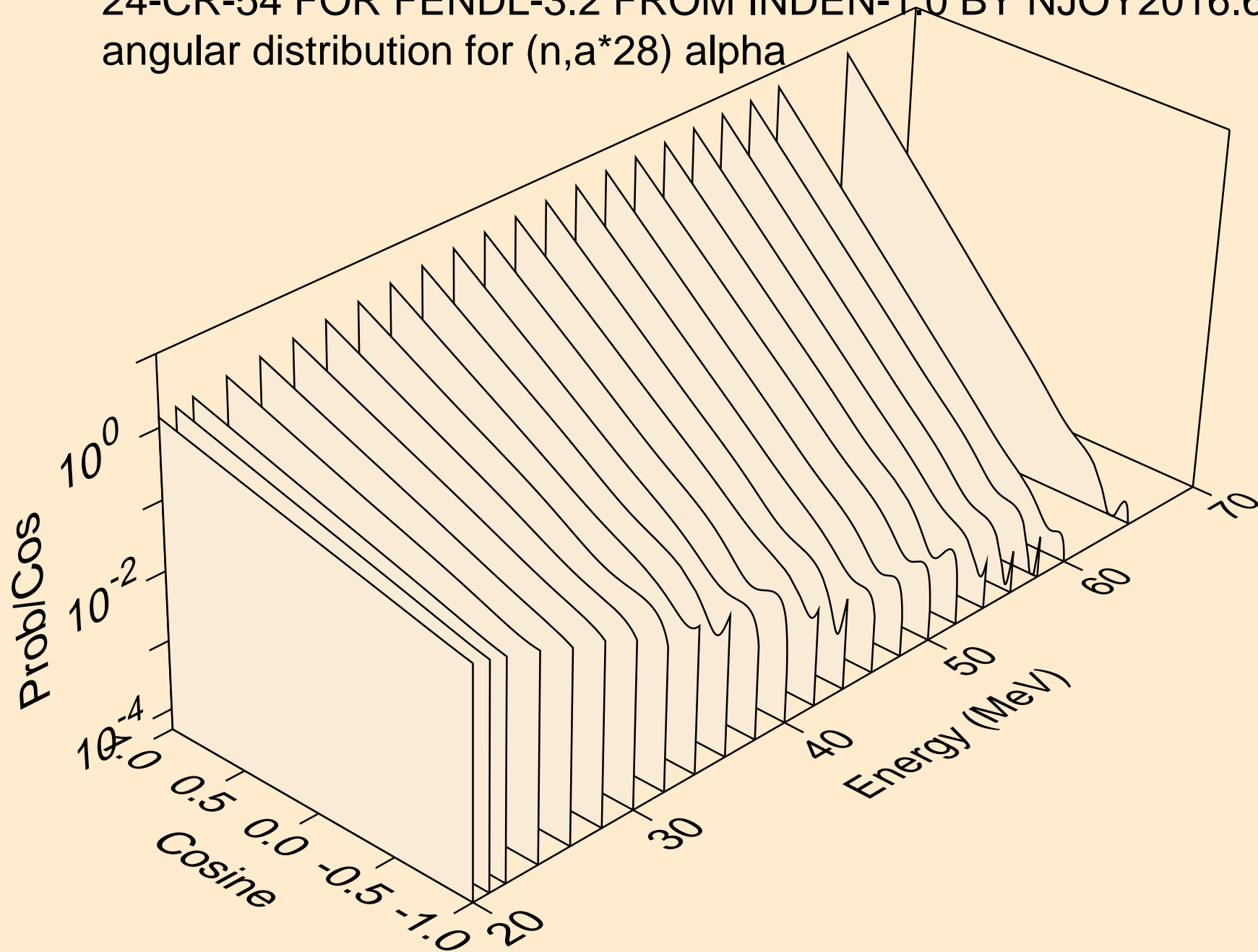

24-CR-54 FOR FENDL-3.2 FROM INDEN-1.0 BY NJOY2016.60+ OI
angular distribution for (n,a*29) alpha

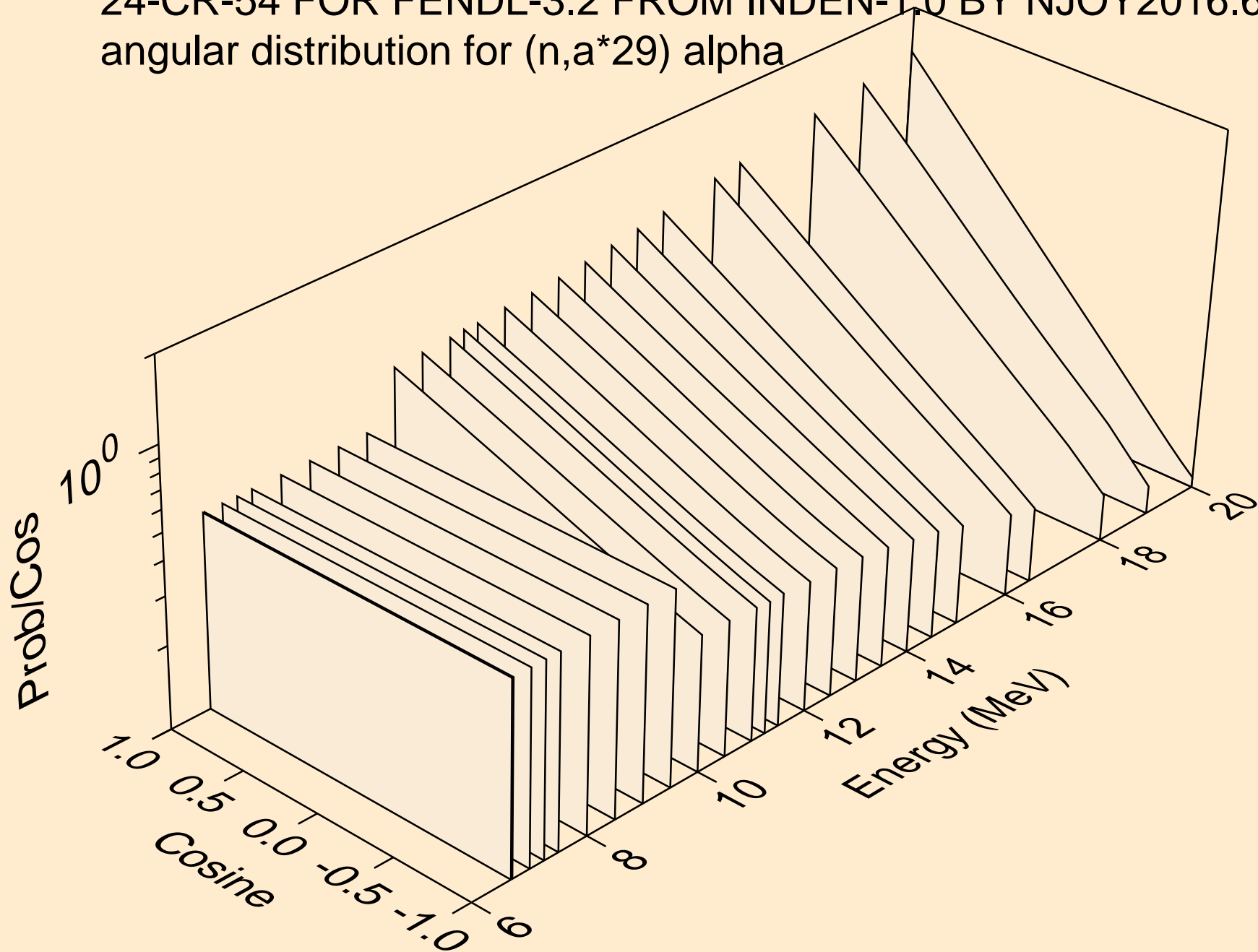

24-CR-54 FOR FENDL-3.2 FROM INDEN-1.0 BY NJOY2016.60+ OI
angular distribution for (n,a*29) alpha

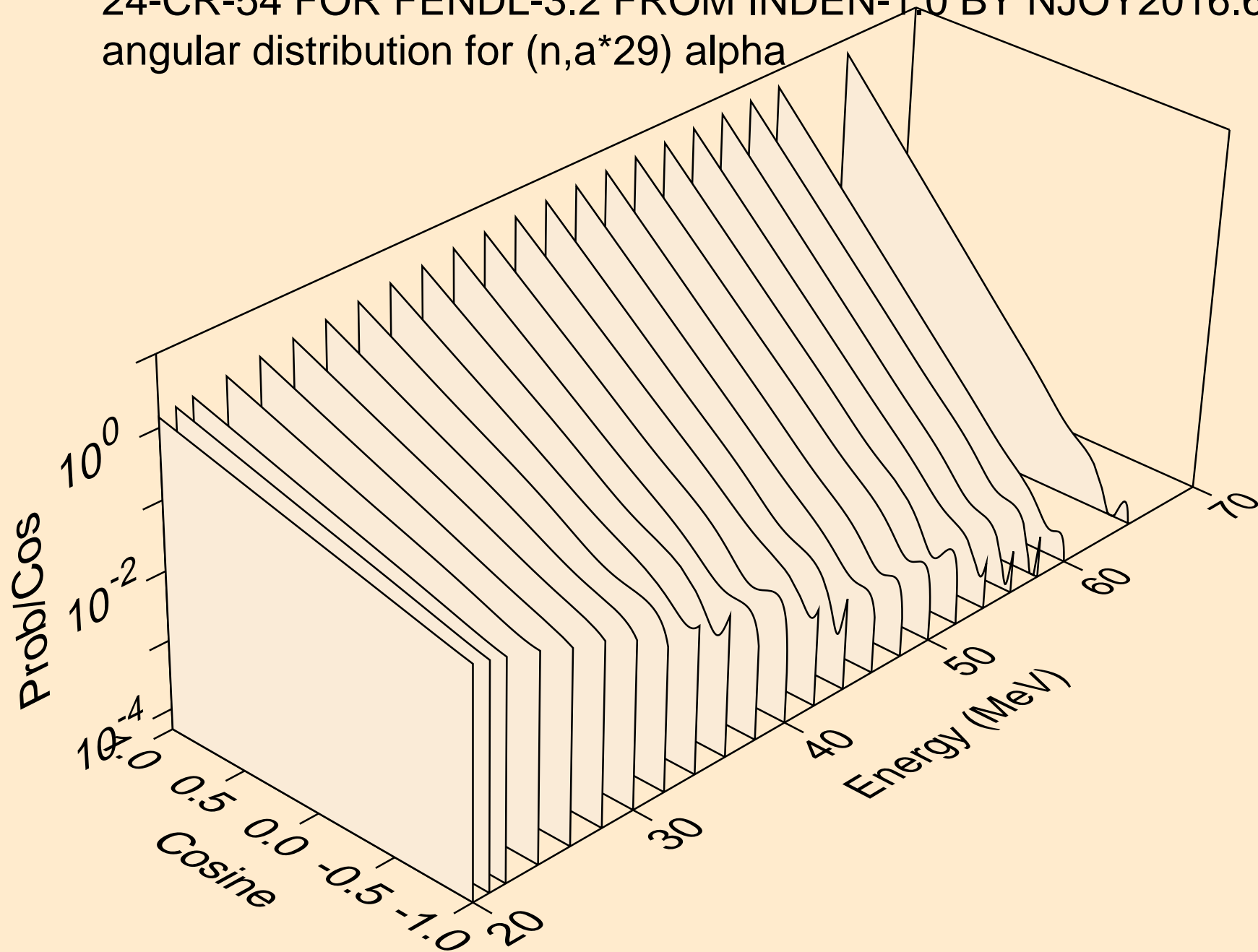

24-CR-54 FOR FENDL-3.2 FROM INDEN-1.0 BY NJOY2016.60+ OI
angular distribution for (n,a*30) alpha

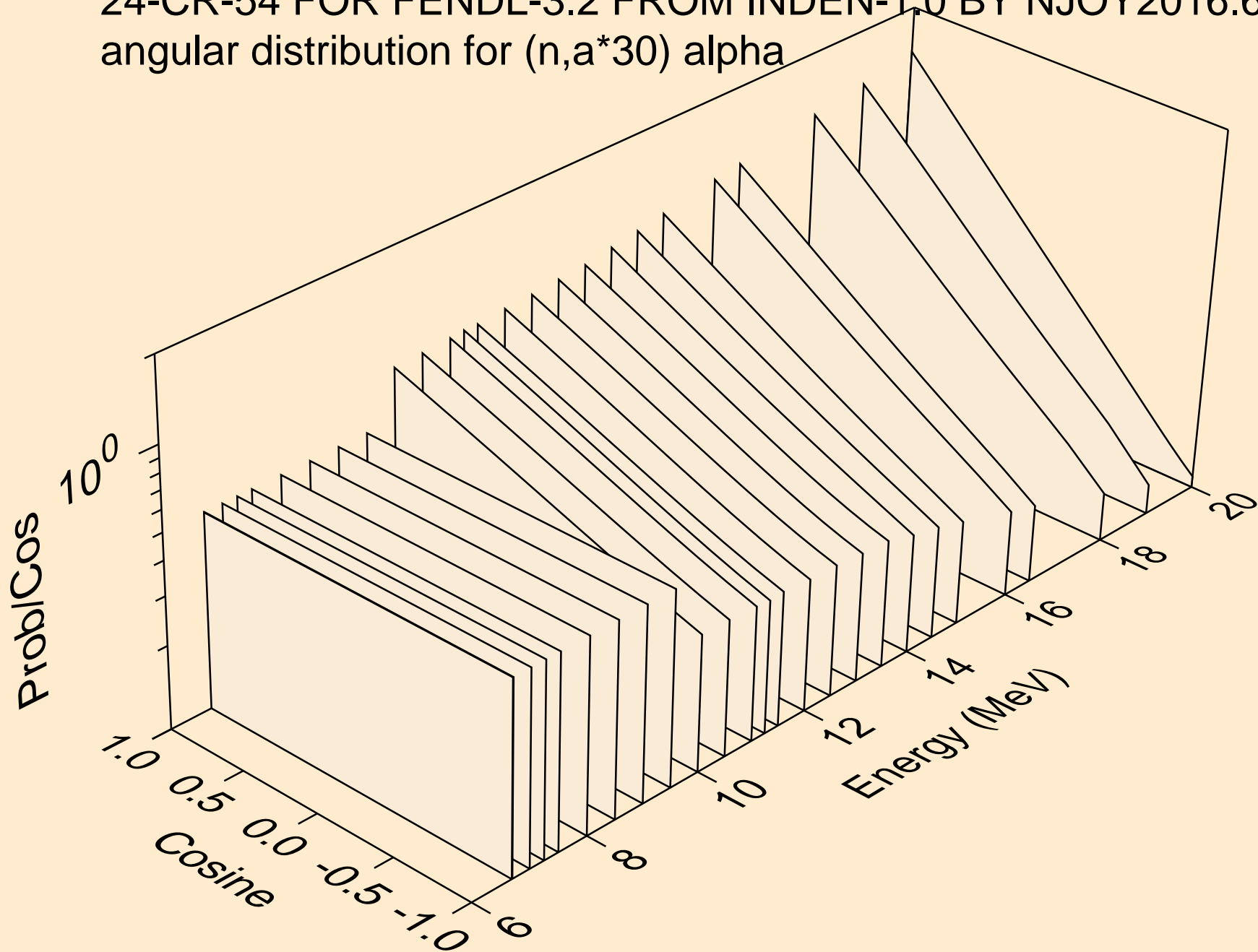

24-CR-54 FOR FENDL-3.2 FROM INDEN-1.0 BY NJOY2016.60+ OI
angular distribution for (n,a*30) alpha

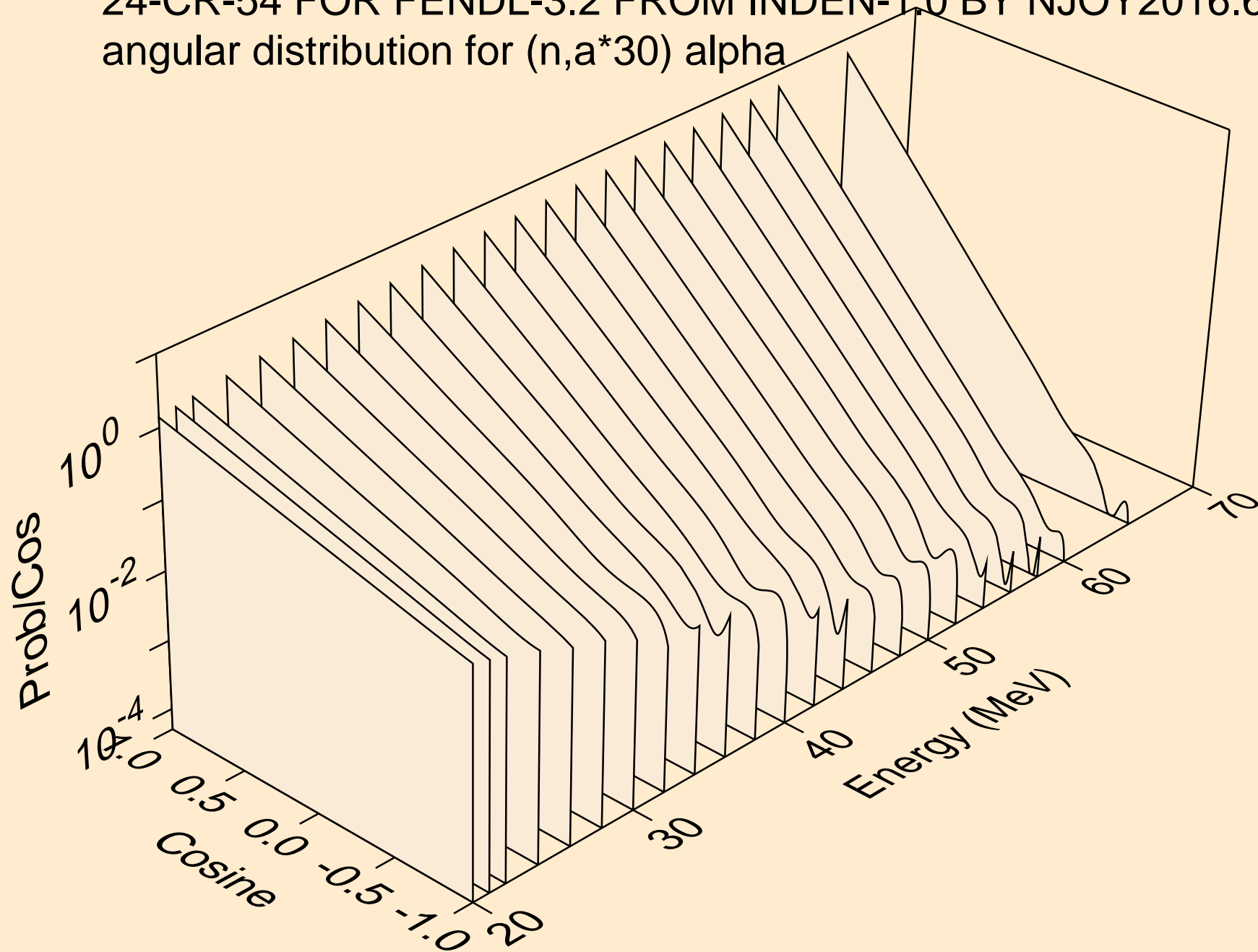

24-CR-54 FOR FENDL-3.2 FROM INDEN-1.0 BY NJOY2016.60+ OI
angular distribution for (n,a*31) alpha

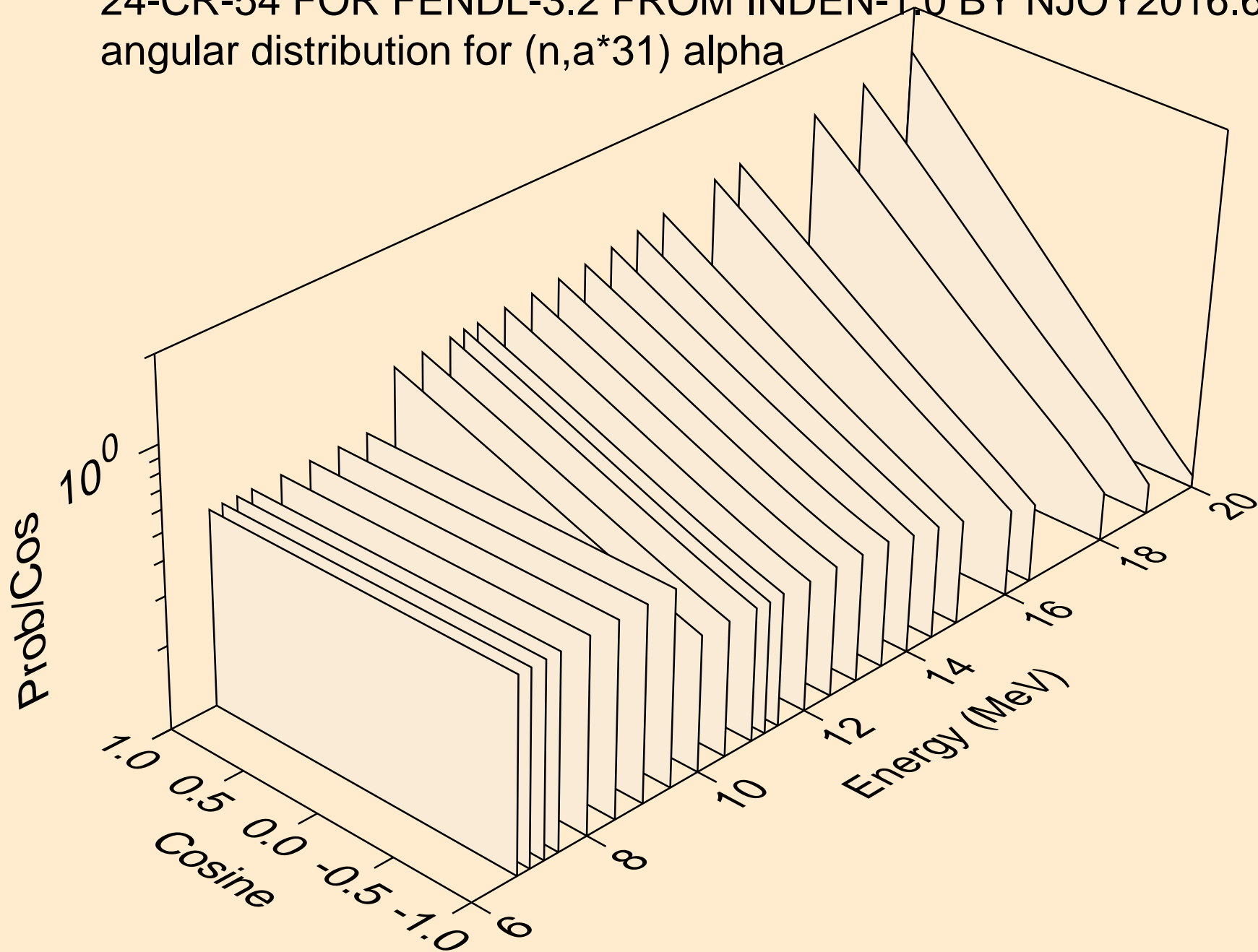

24-CR-54 FOR FENDL-3.2 FROM INDEN-1.0 BY NJOY2016.60+ OI
angular distribution for (n,a*31) alpha

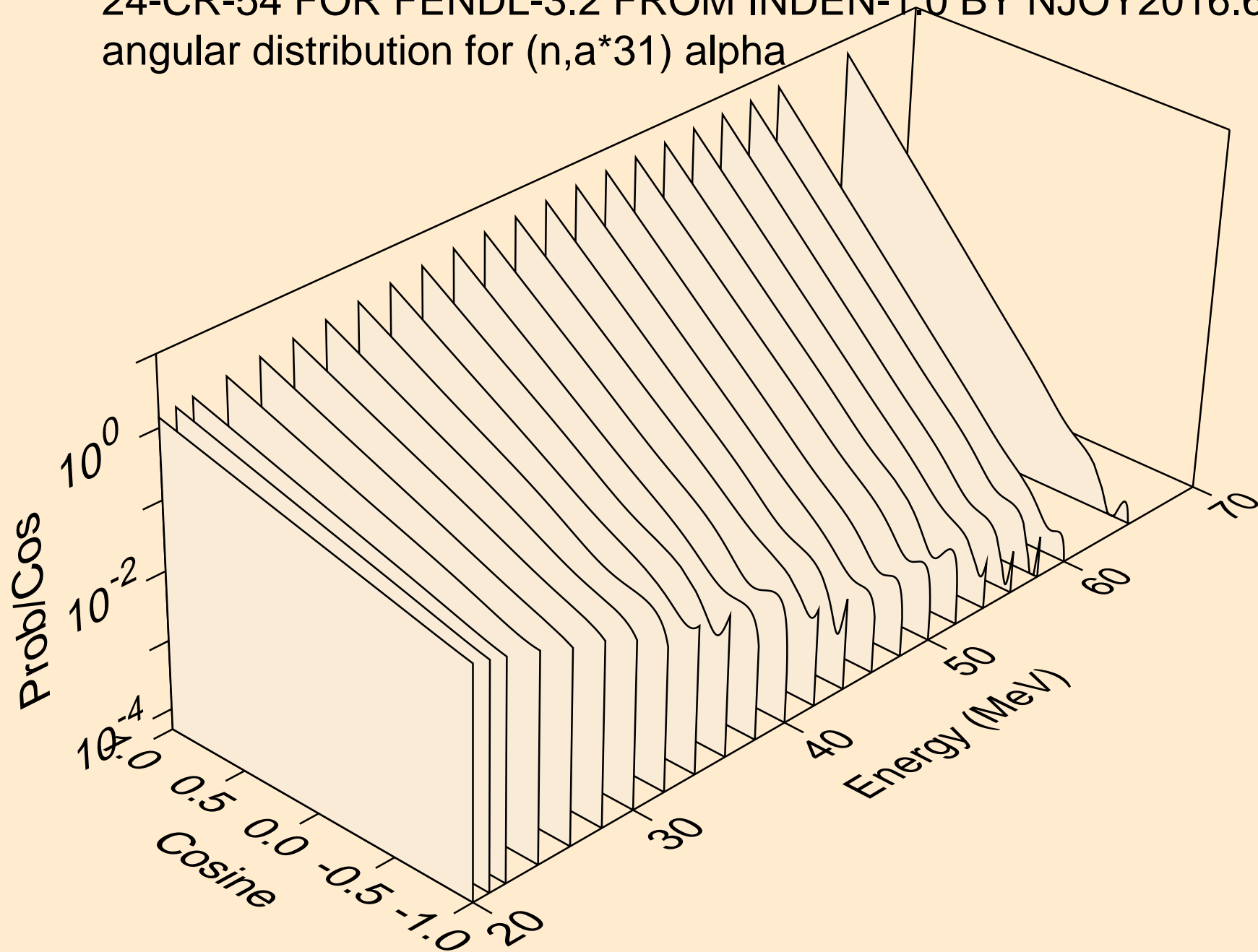

24-CR-54 FOR FENDL-3.2 FROM INDEN-1.0 BY NJOY2016.60+ OI
angular distribution for (n,a*32) alpha

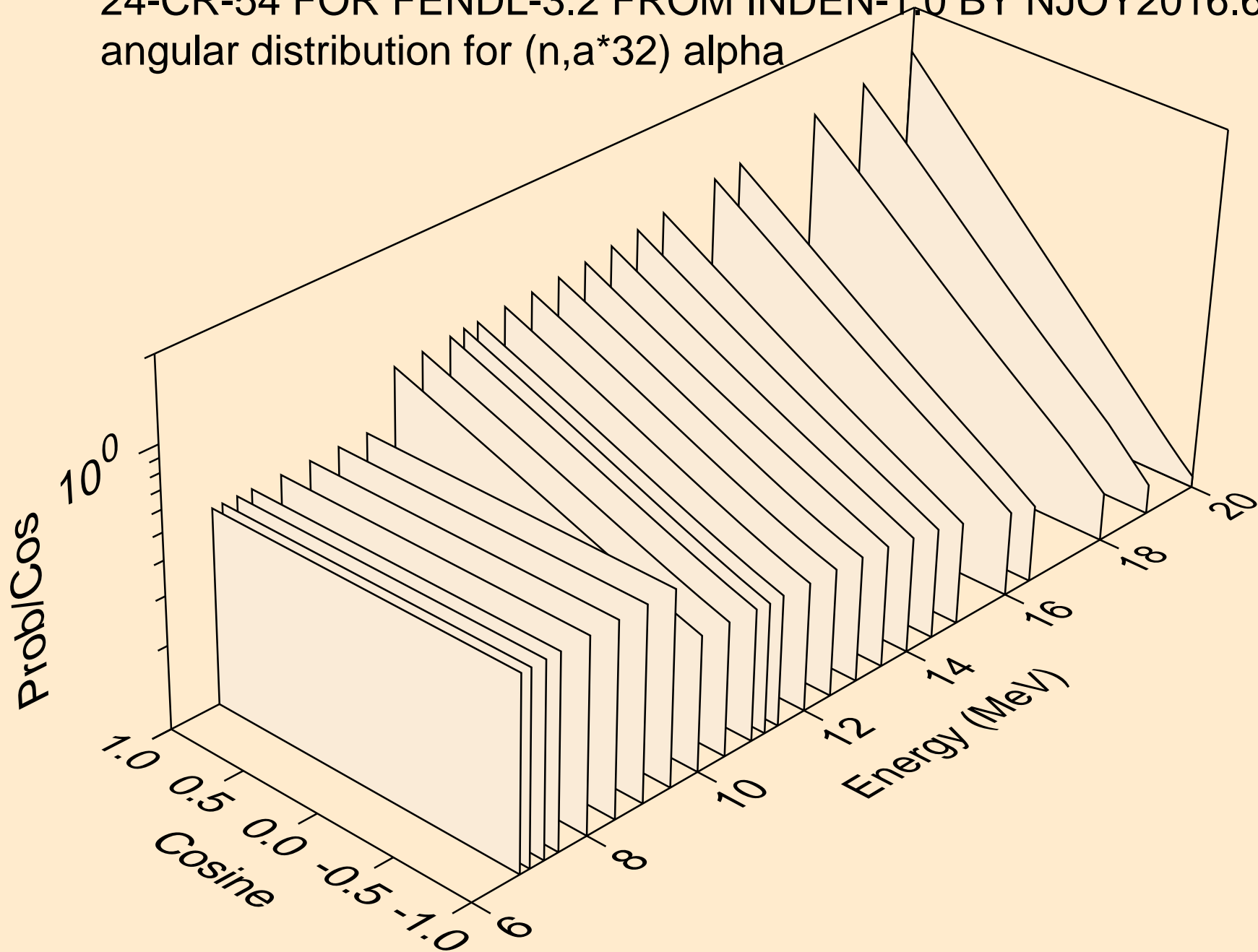

24-CR-54 FOR FENDL-3.2 FROM INDEN-1.0 BY NJOY2016.60+ OI
angular distribution for (n,a*32) alpha

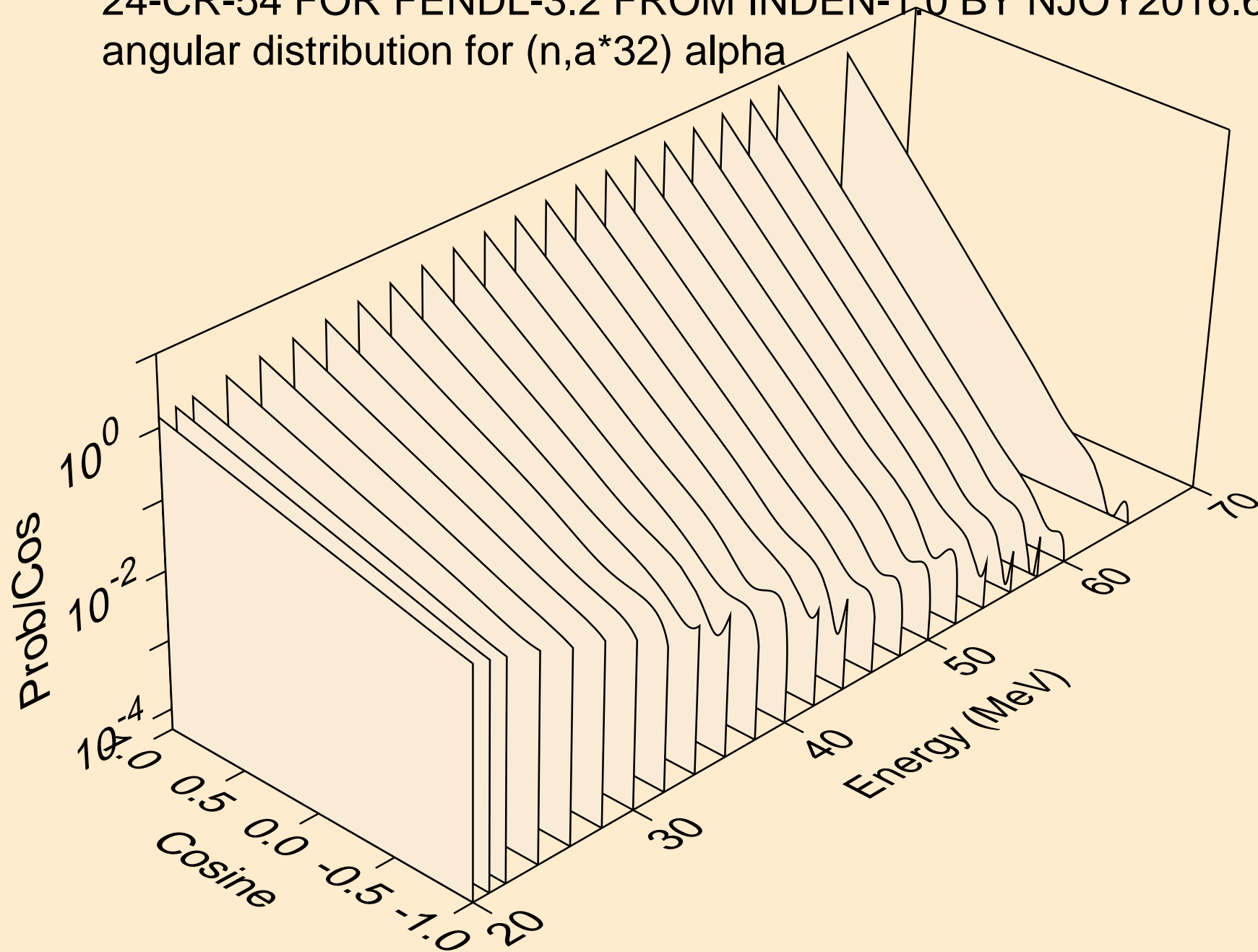

24-CR-54 FOR FENDL-3.2 FROM INDEN-1.0 BY NJOY2016.60+ OI
angular distribution for (n, α *33) alpha

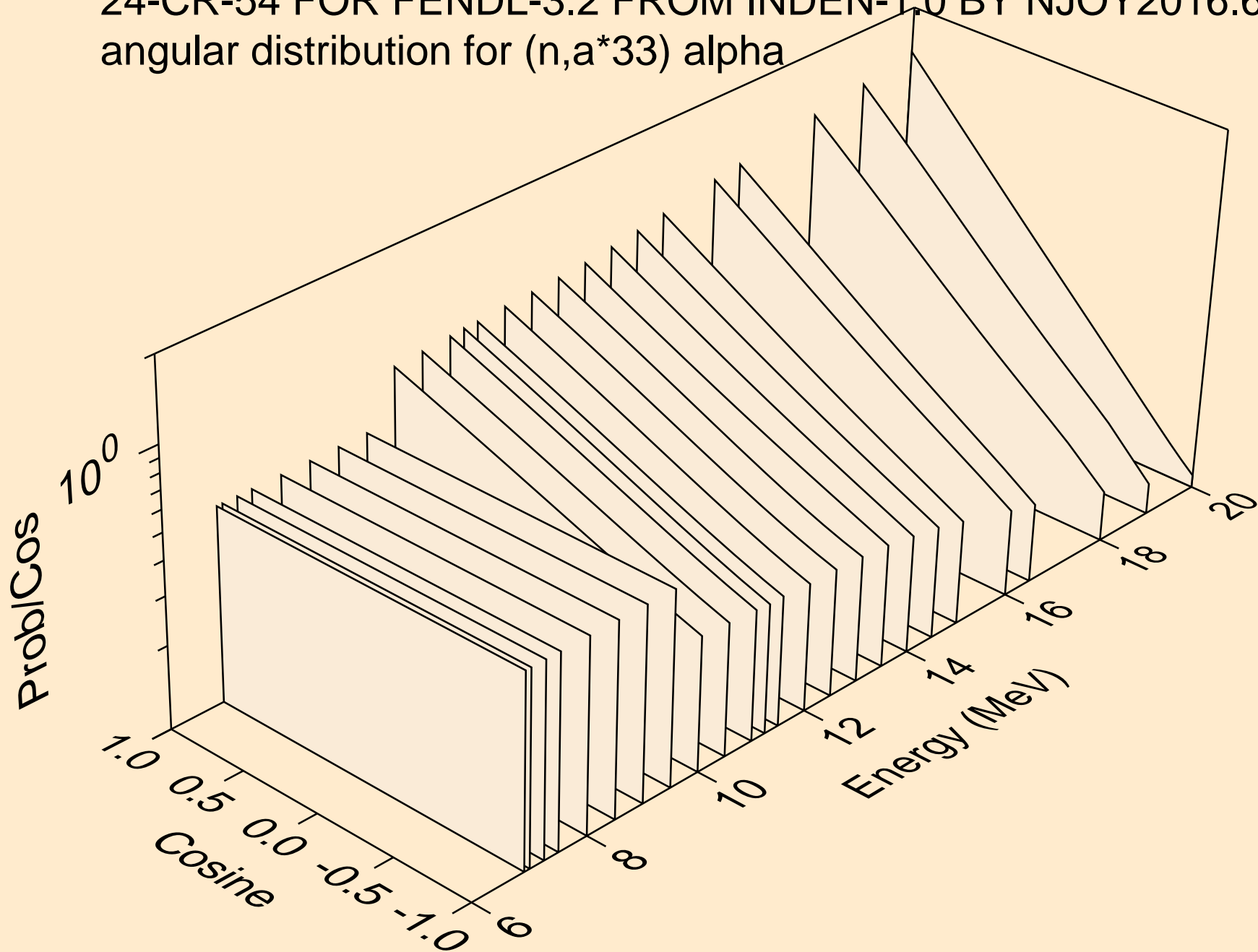

24-CR-54 FOR FENDL-3.2 FROM INDEN-1.0 BY NJOY2016.60+ OI
angular distribution for (n, α *33) alpha

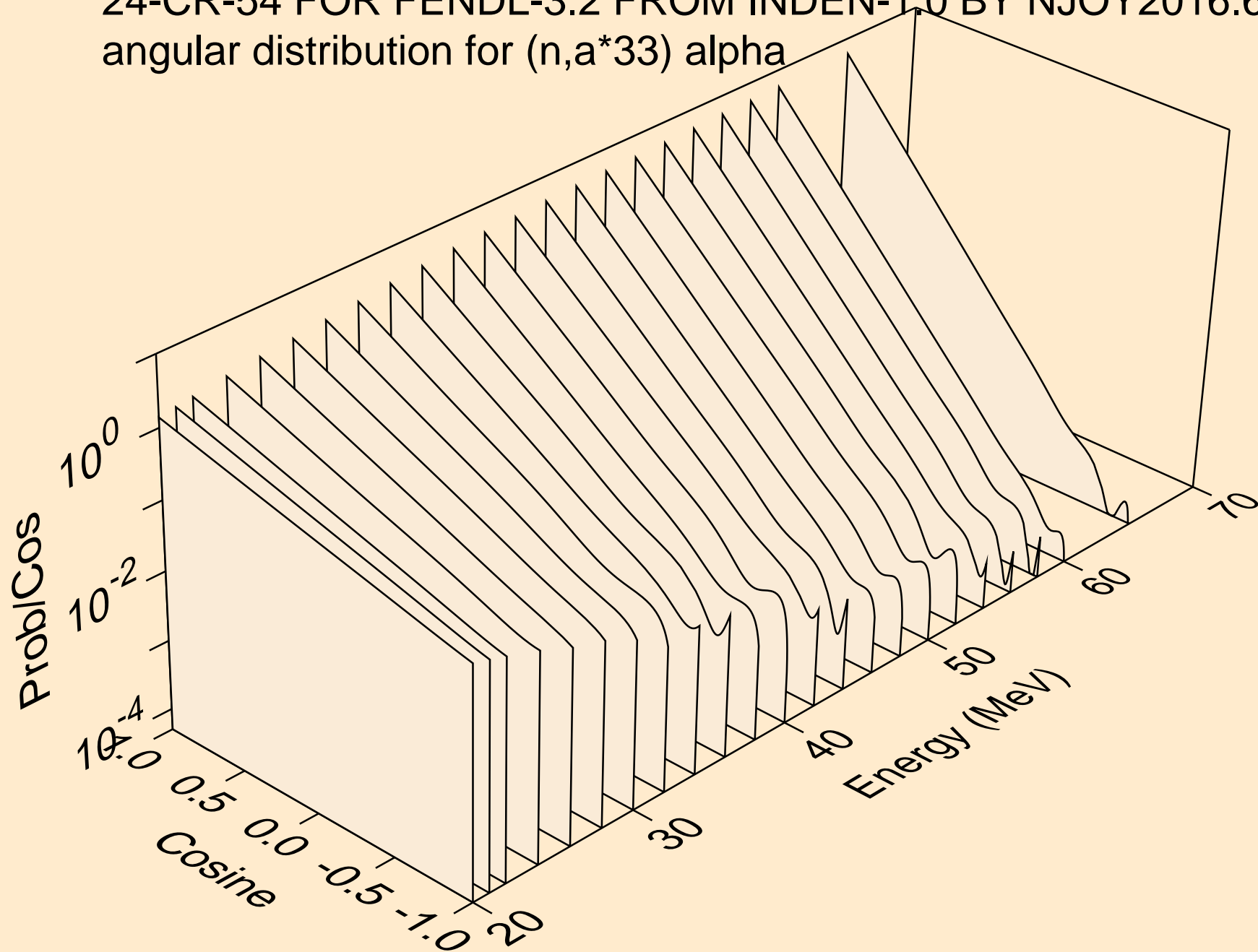

24-CR-54 FOR FENDL-3.2 FROM INDEN-1.0 BY NJOY2016.60+ OI
angular distribution for (n,a*34) alpha

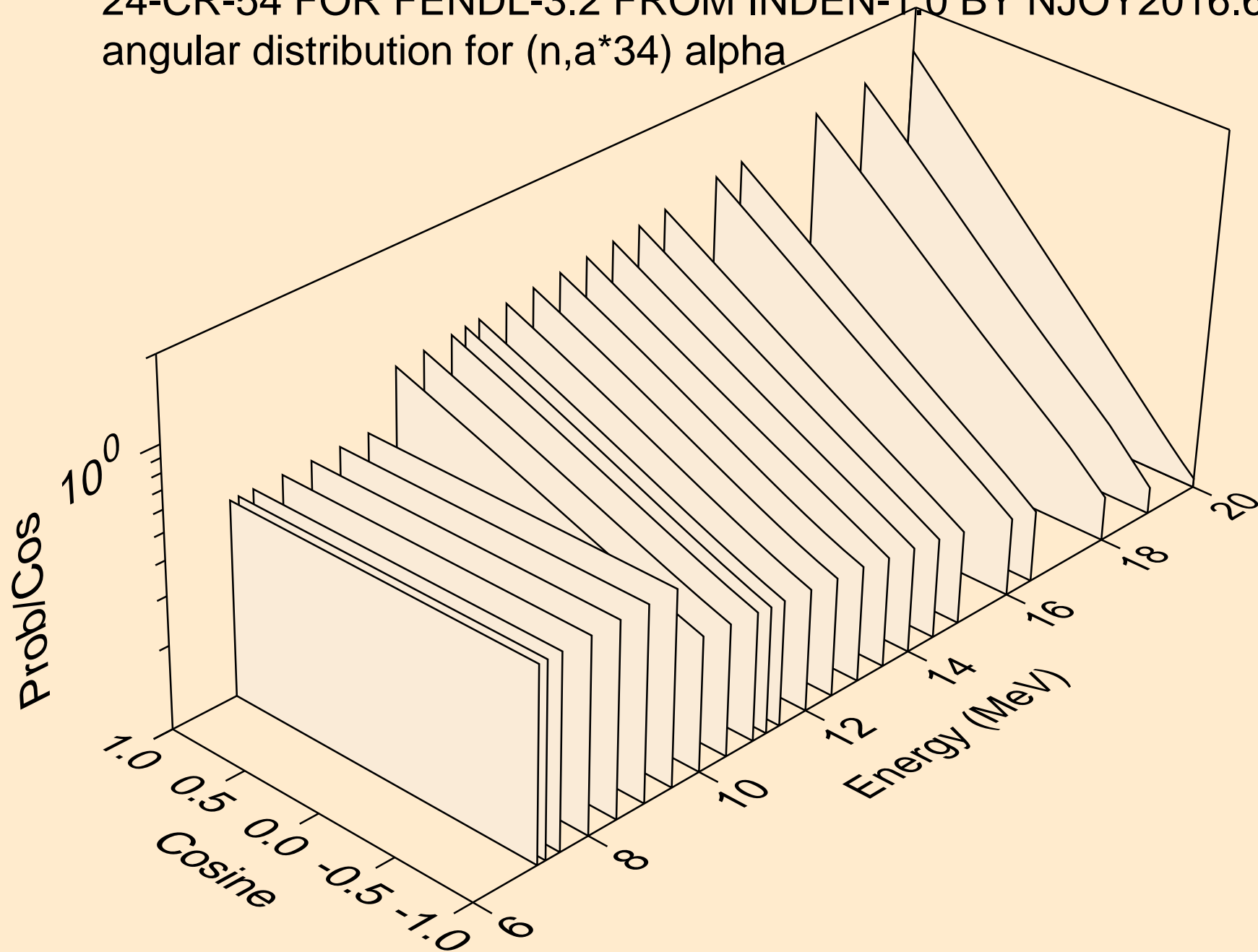

24-CR-54 FOR FENDL-3.2 FROM INDEN-1.0 BY NJOY2016.60+ OI
angular distribution for (n, α *34) alpha

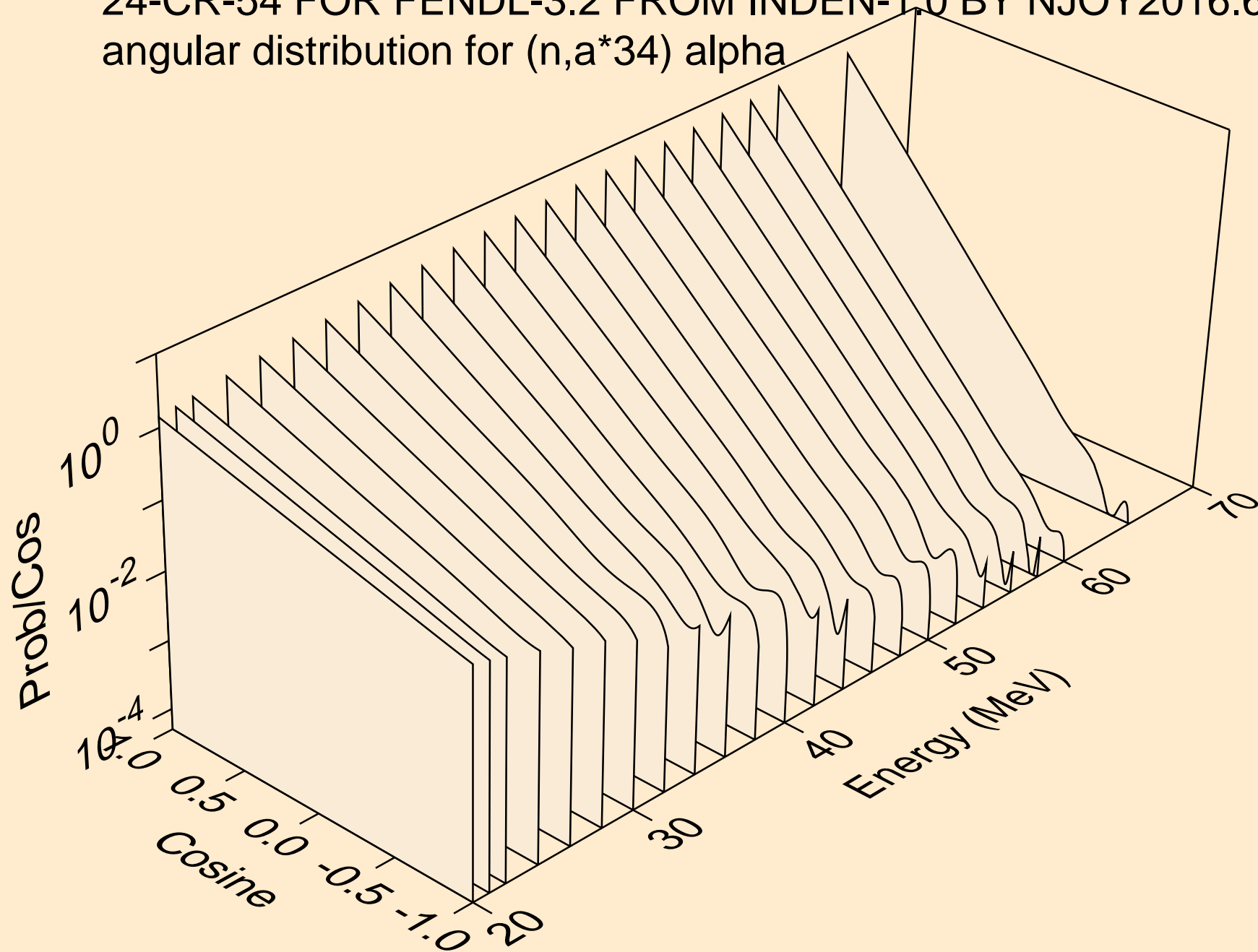

24-CR-54 FOR FENDL-3.2 FROM INDEN-1.0 BY NJOY2016.60+ OI
alphas from (n,a*c)

