

26-FE-58 FOR FENDL-3.2 FROM JEFF-3.1.1 BY NJOY2016.60+ ON
Principal cross sections

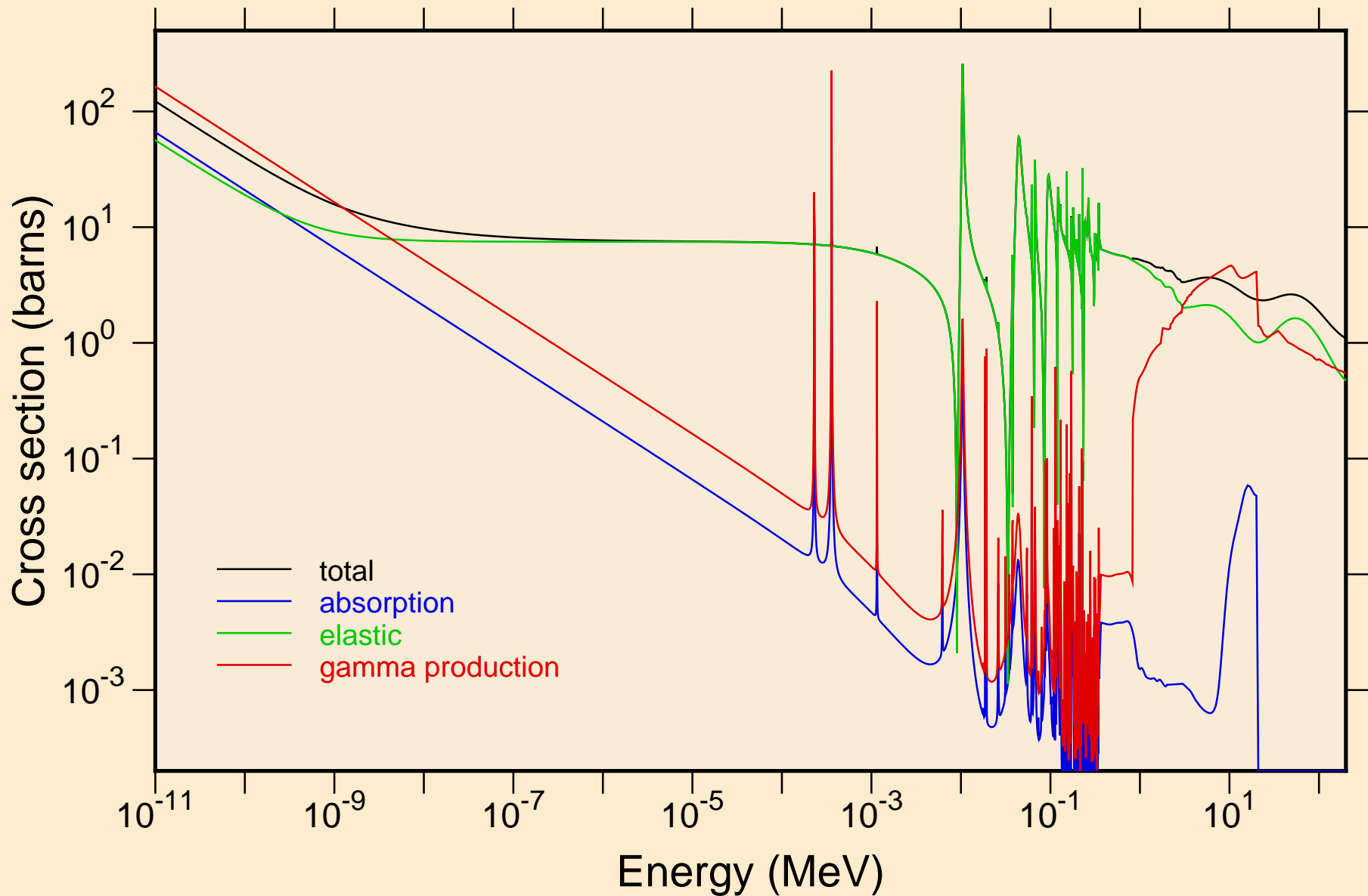

26-FE-58 FOR FENDL-3.2 FROM JEFF-3.1.1 BY NJOY2016.60+ ON
resonance total cross section

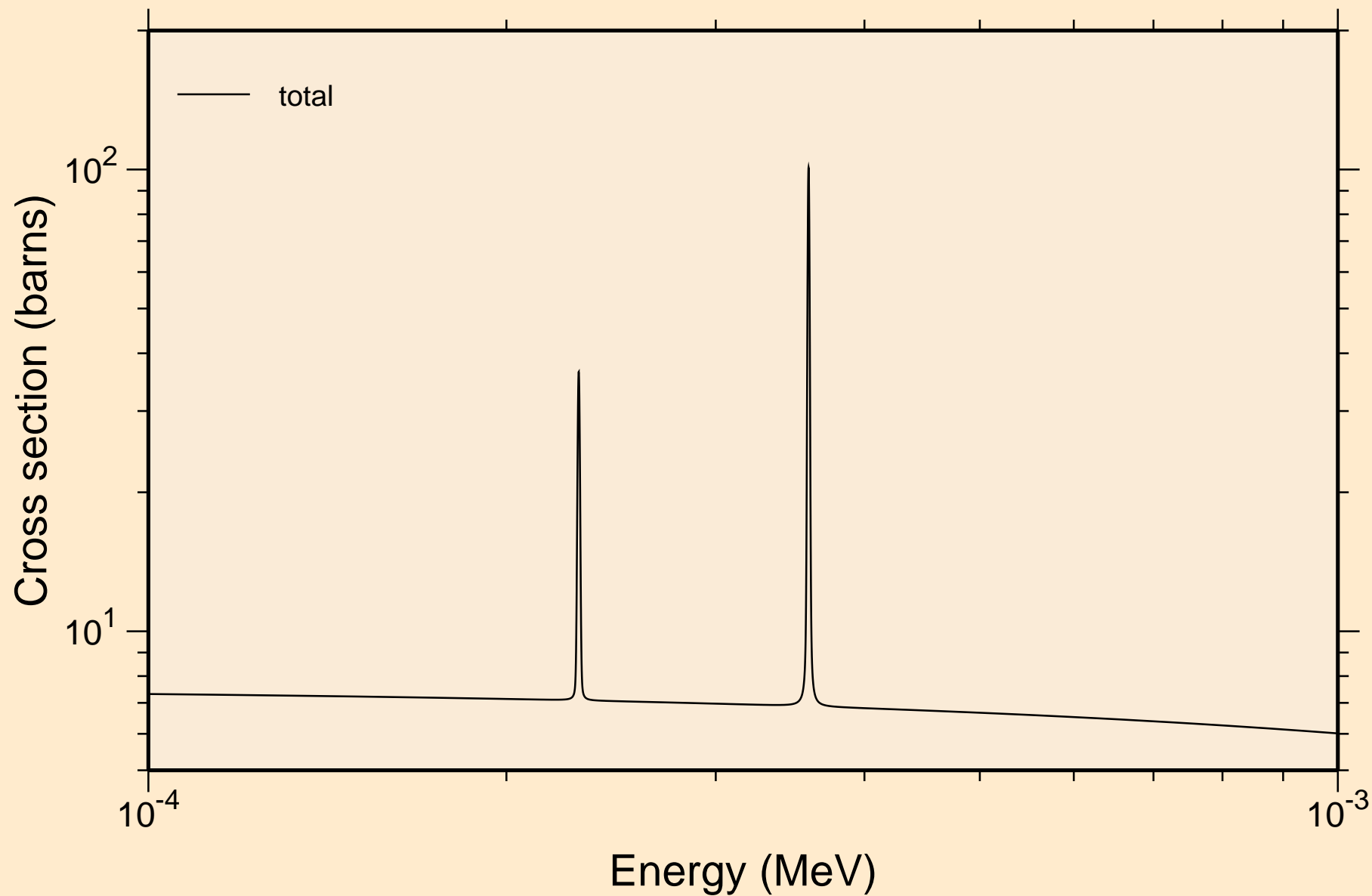

26-FE-58 FOR FENDL-3.2 FROM JEFF-3.1.1 BY NJOY2016.60+ ON
resonance total cross section

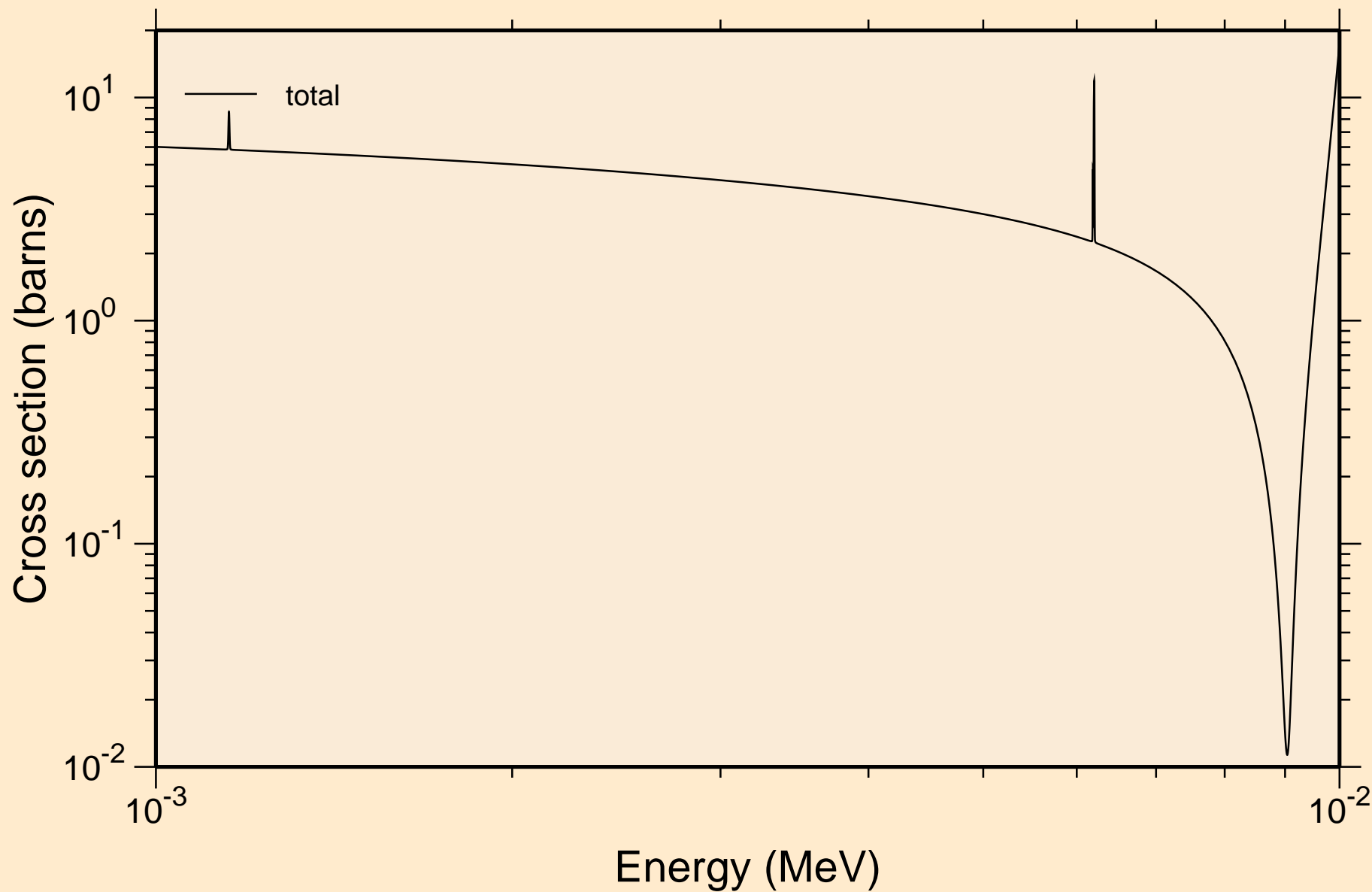

26-FE-58 FOR FENDL-3.2 FROM JEFF-3.1.1 BY NJOY2016.60+ ON
resonance total cross section

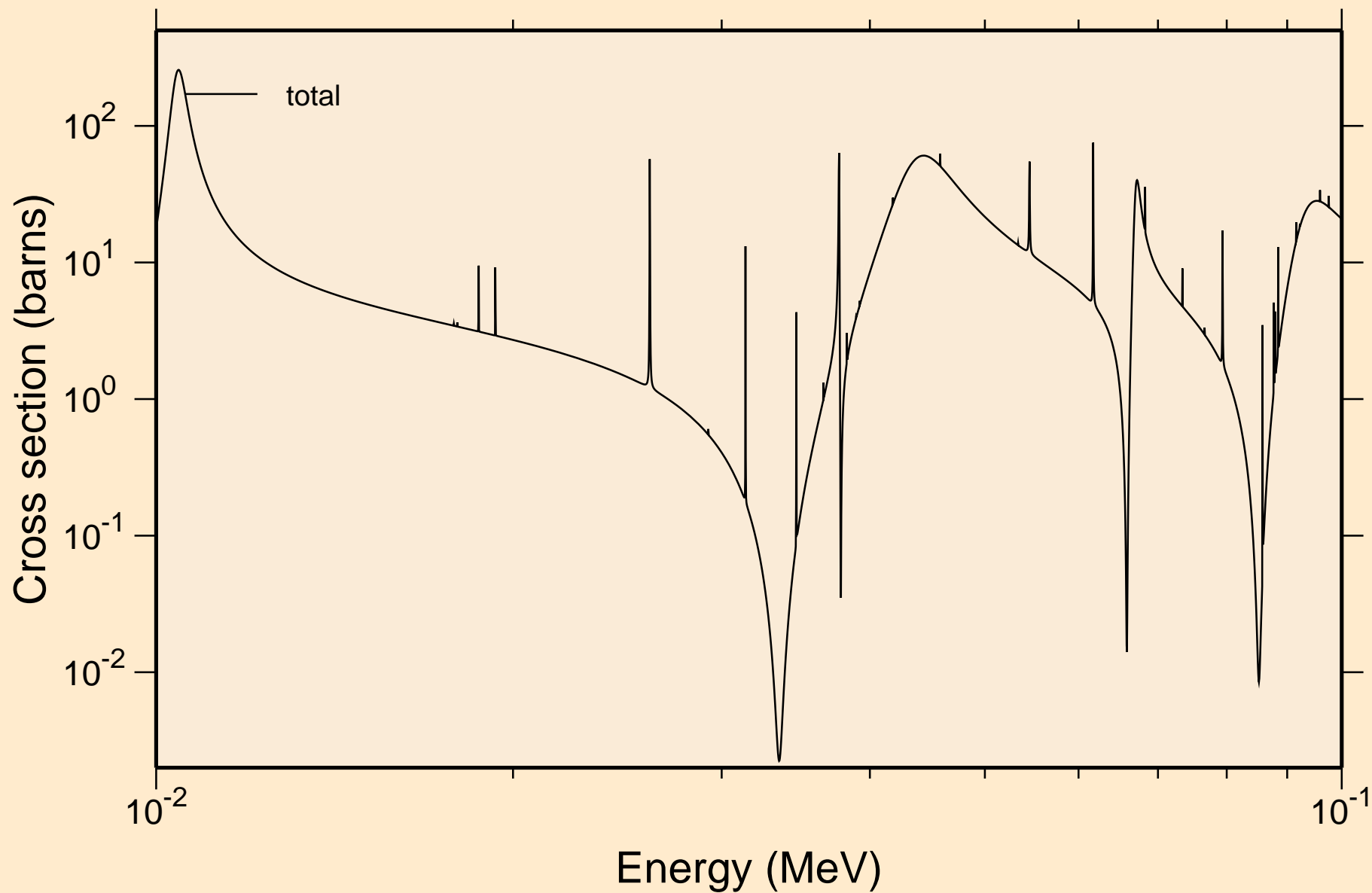

26-FE-58 FOR FENDL-3.2 FROM JEFF-3.1.1 BY NJOY2016.60+ ON
resonance total cross section

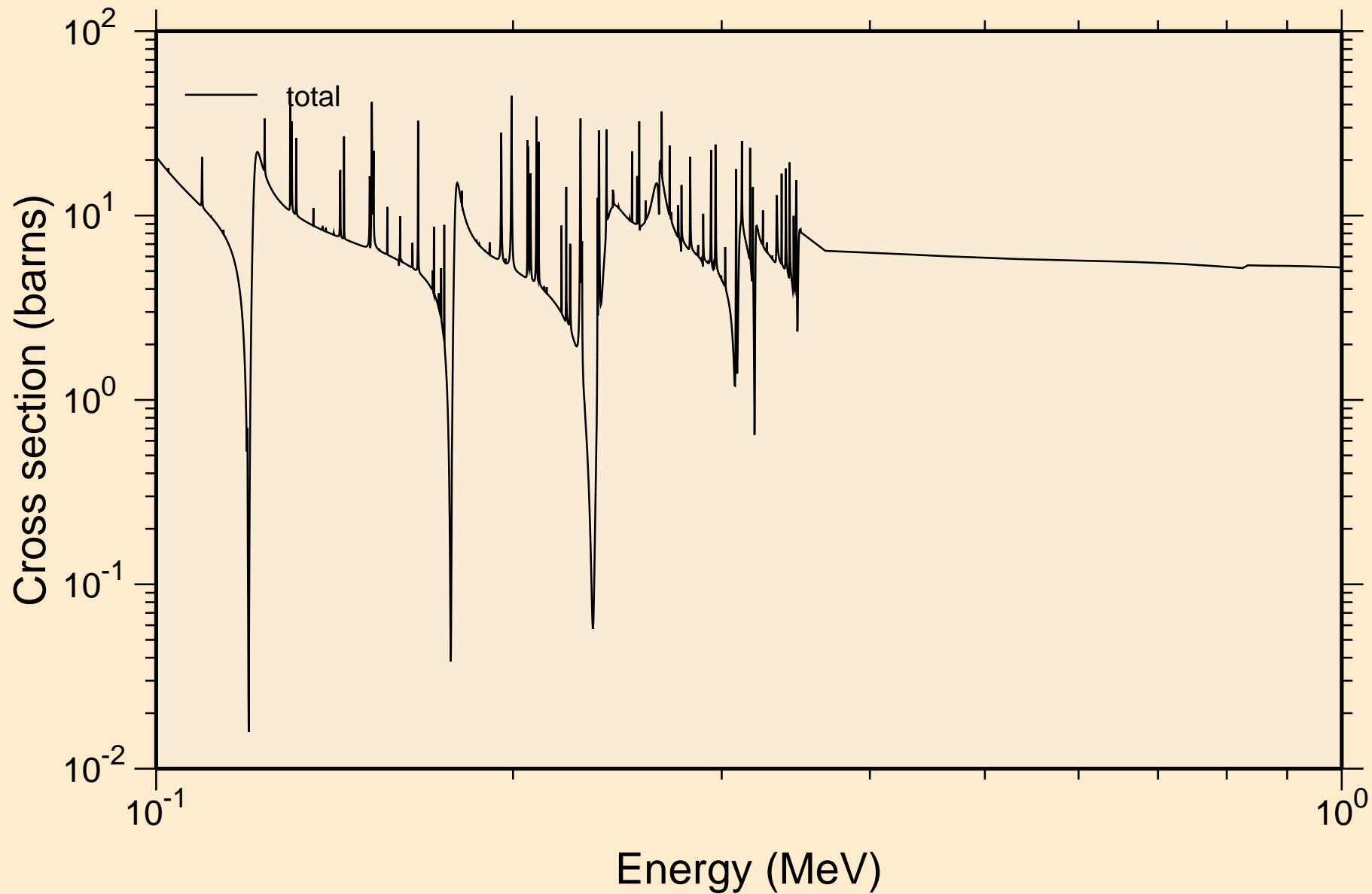

26-FE-58 FOR FENDL-3.2 FROM JEFF-3.1.1 BY NJOY2016.60+ ON
resonance total cross section

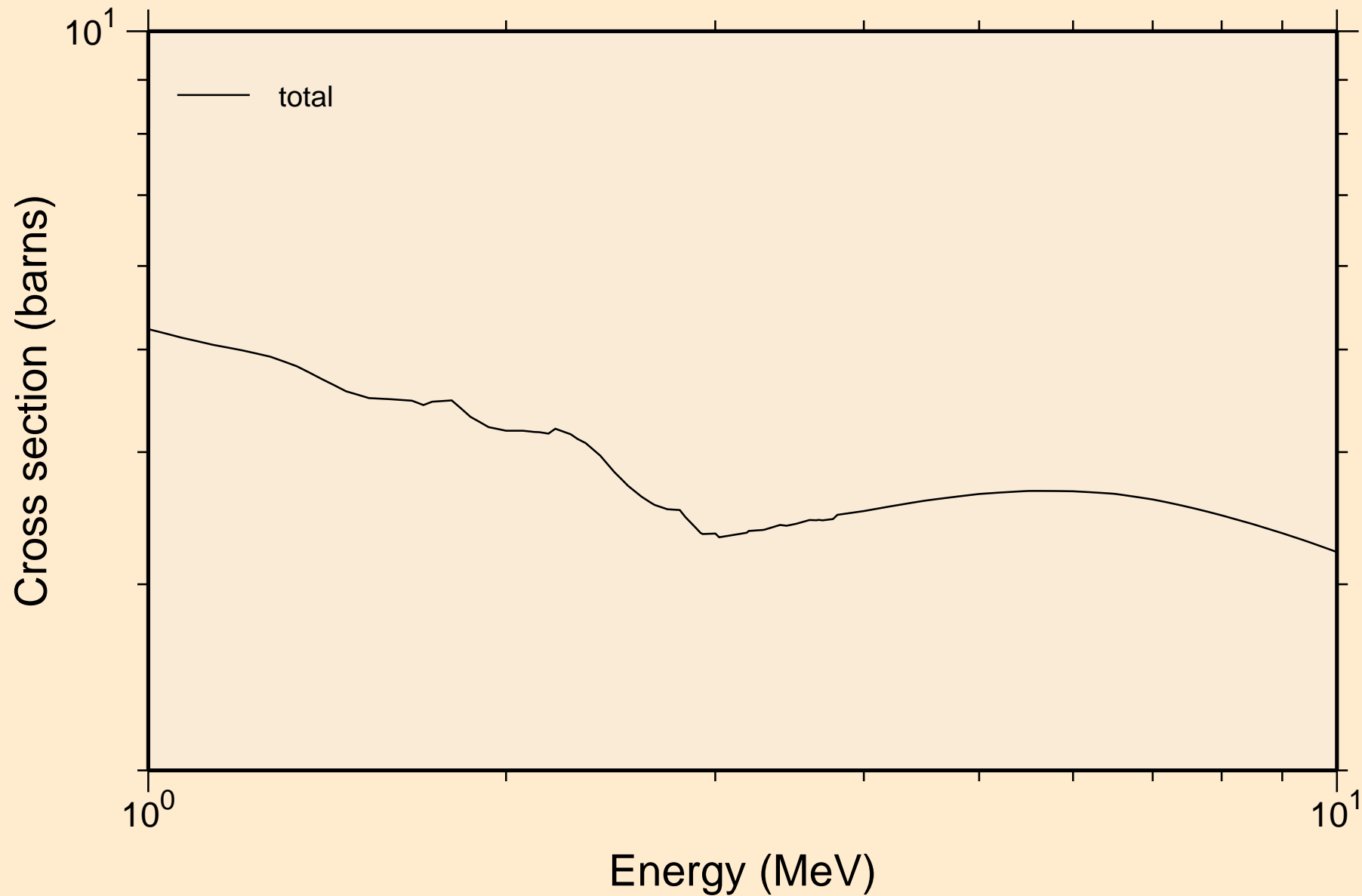

26-FE-58 FOR FENDL-3.2 FROM JEFF-3.1.1 BY NJOY2016.60+ ON
resonance absorption cross sections

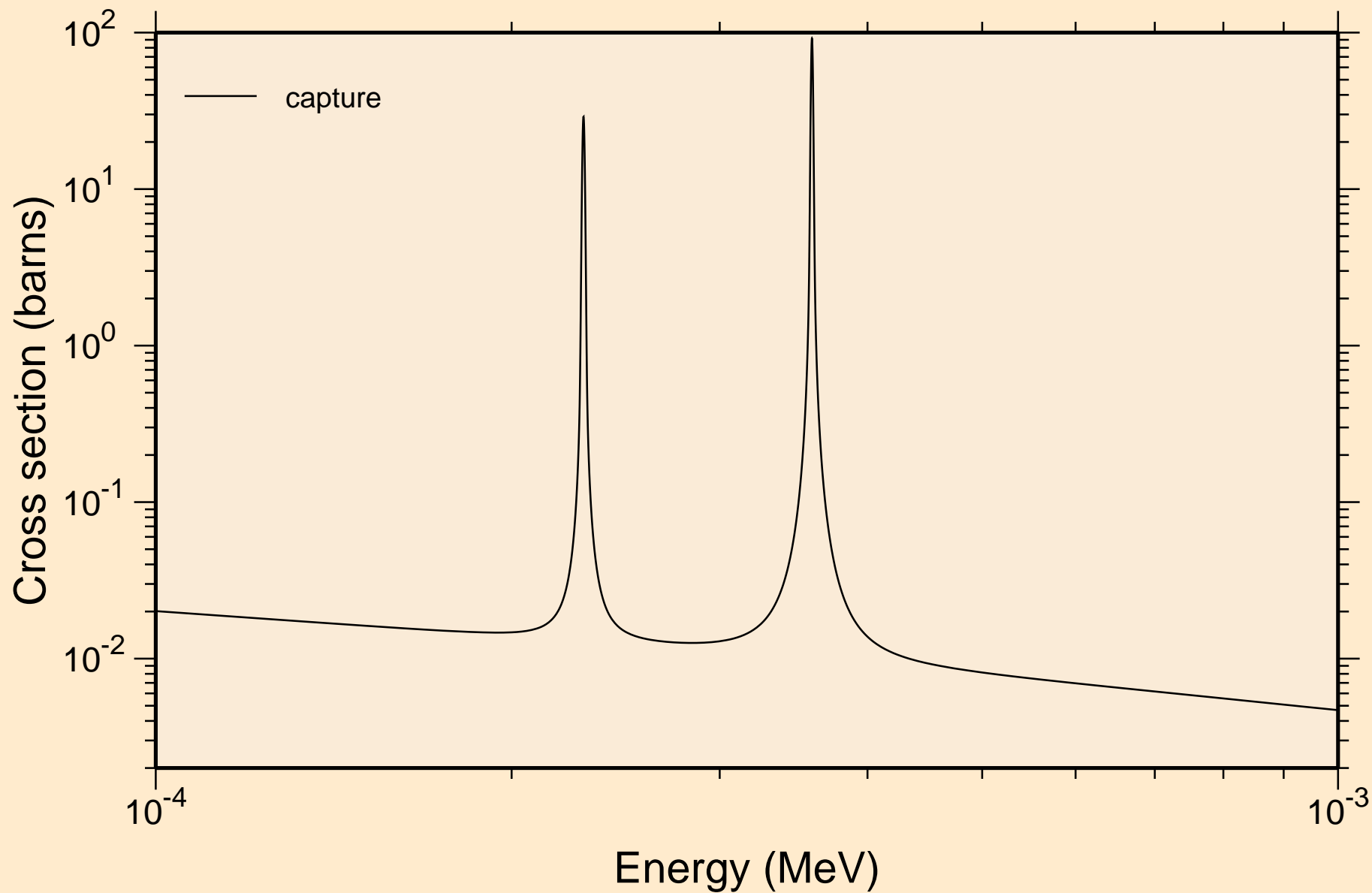

26-FE-58 FOR FENDL-3.2 FROM JEFF-3.1.1 BY NJOY2016.60+ ON
resonance absorption cross sections

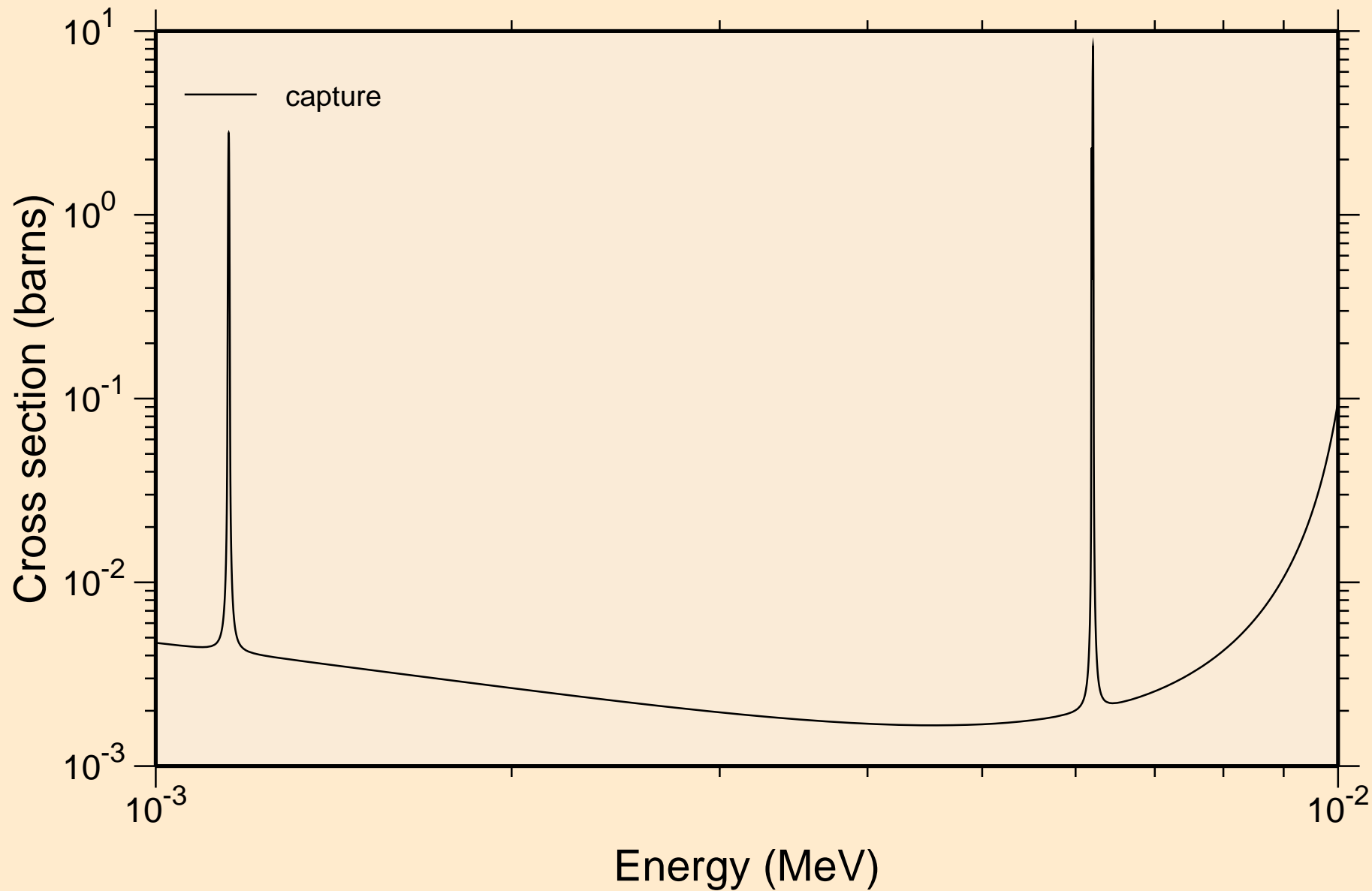

26-FE-58 FOR FENDL-3.2 FROM JEFF-3.1.1 BY NJOY2016.60+ ON
resonance absorption cross sections

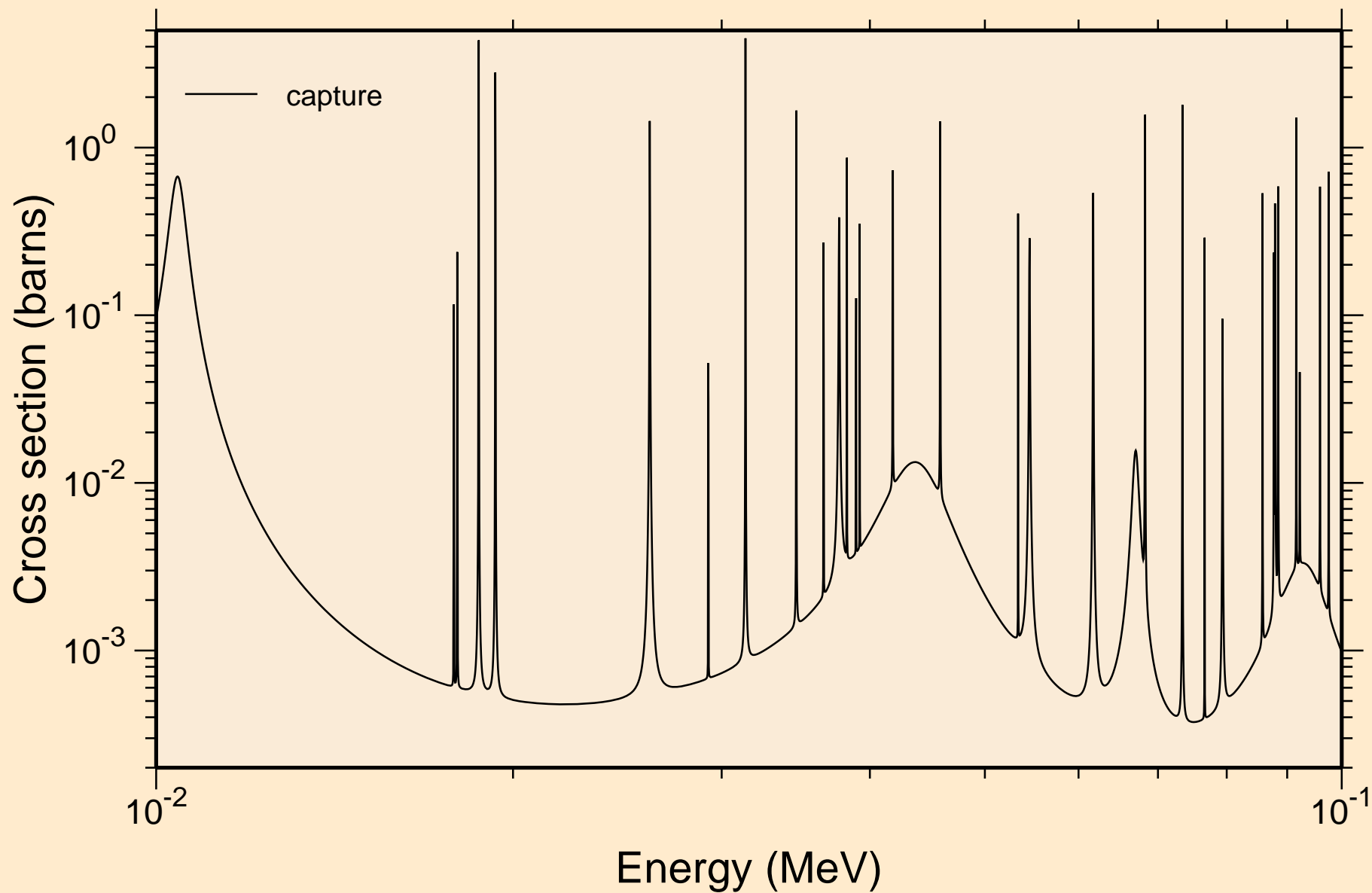

26-FE-58 FOR FENDL-3.2 FROM JEFF-3.1.1 BY NJOY2016.60+ ON
resonance absorption cross sections

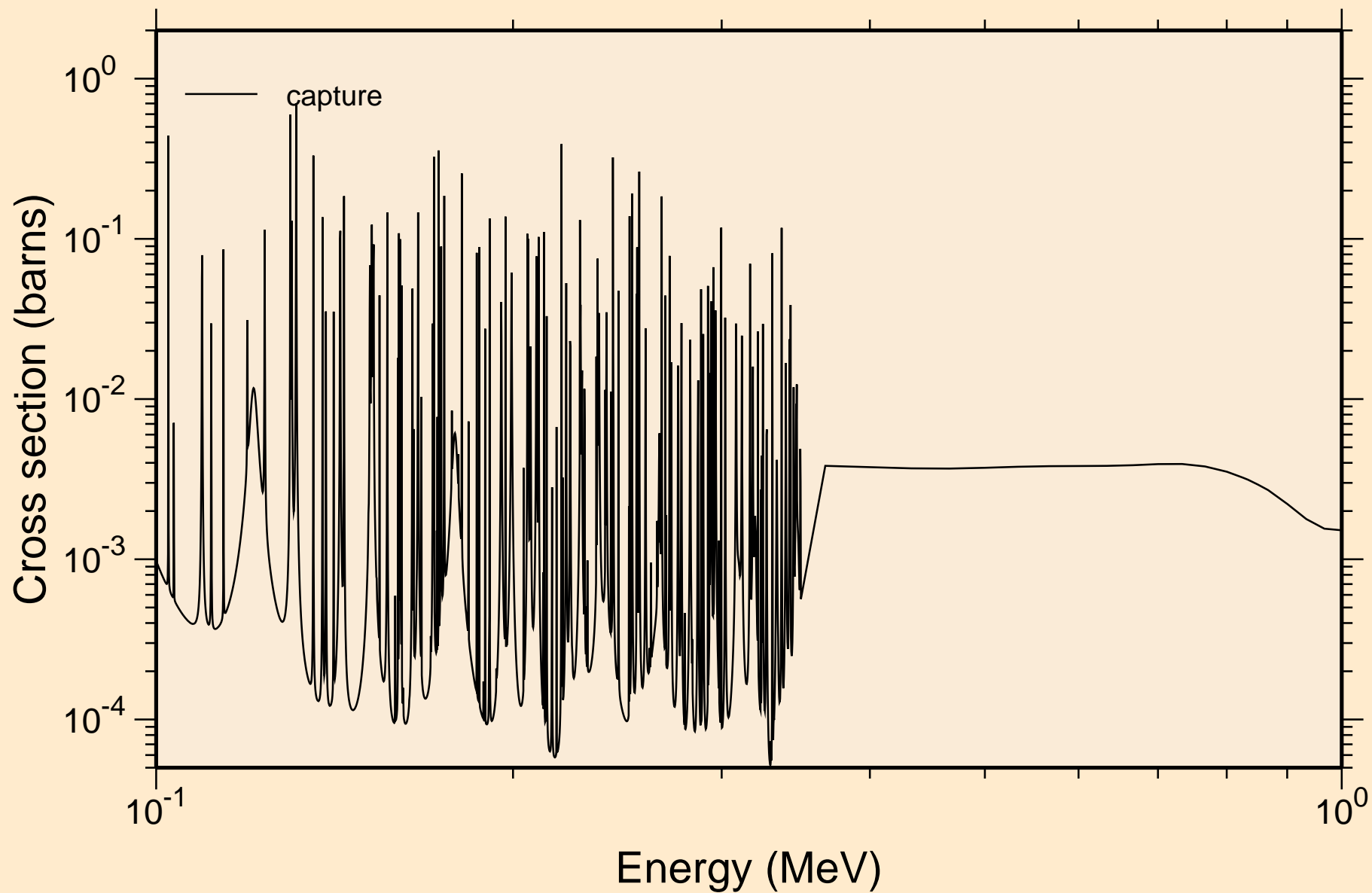

26-FE-58 FOR FENDL-3.2 FROM JEFF-3.1.1 BY NJOY2016.60+ ON
resonance absorption cross sections

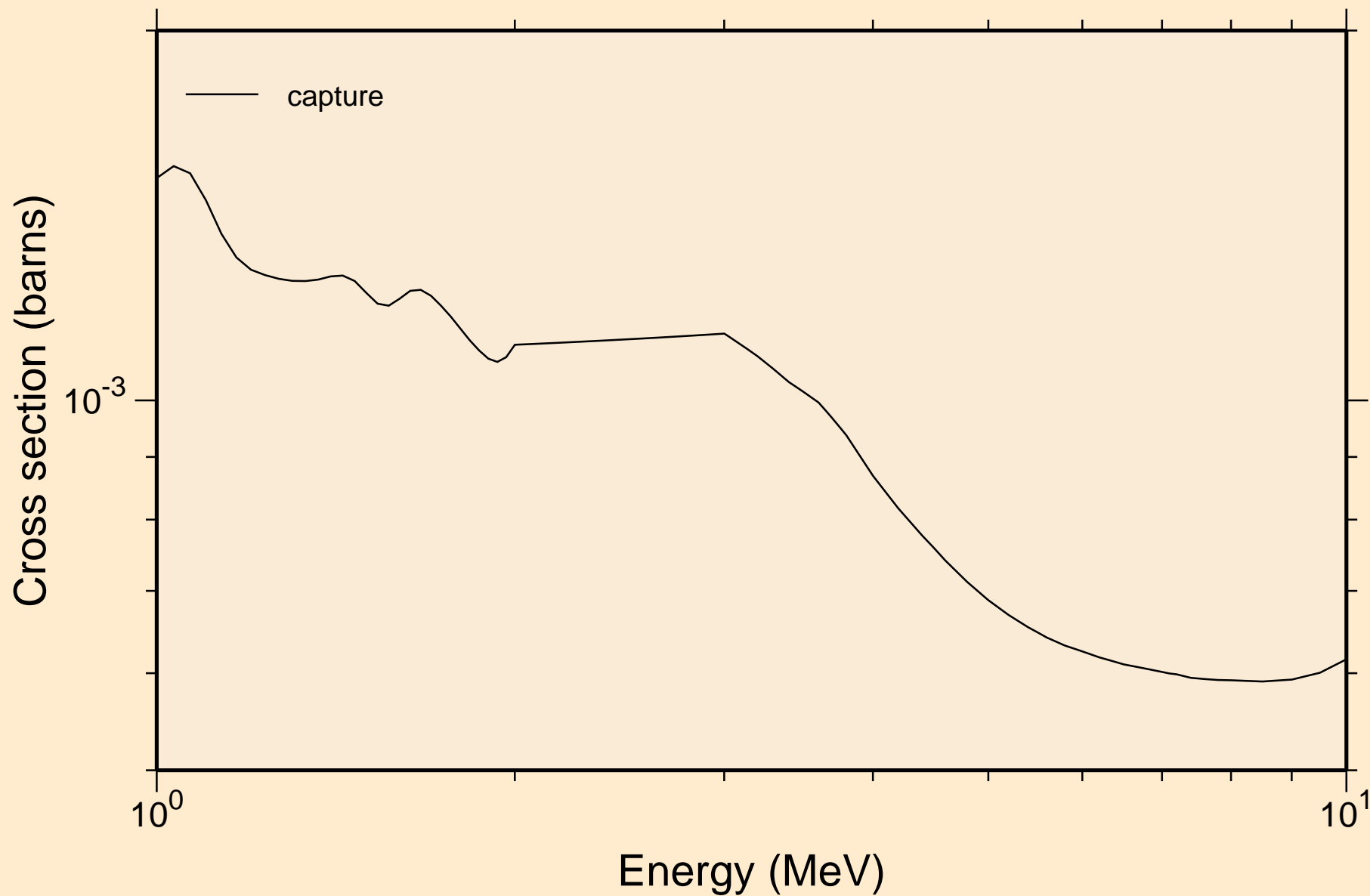

26-FE-58 FOR FENDL-3.2 FROM JEFF-3.1.1 BY NJOY2016.60+ ON
UR total cross section

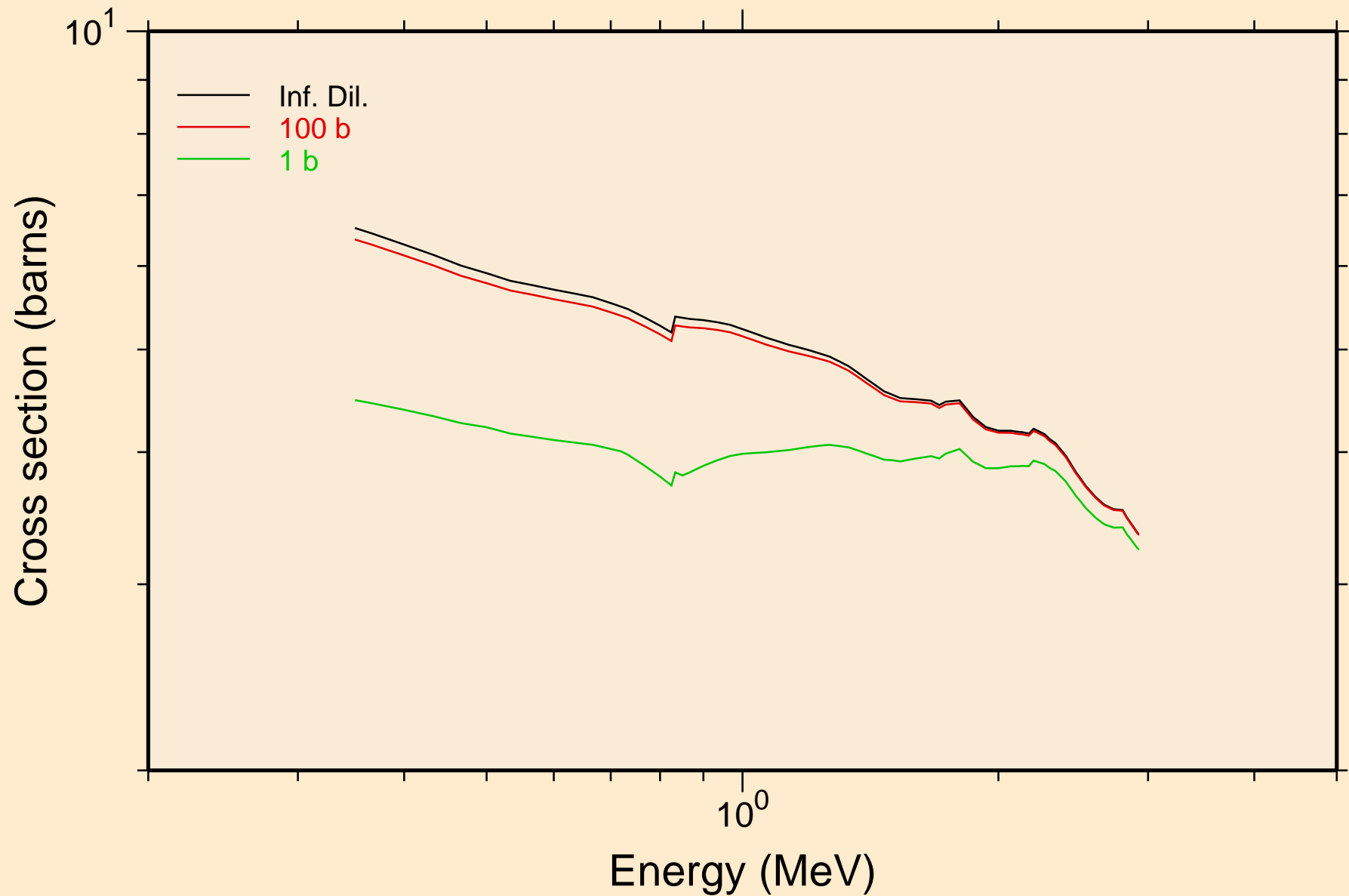

26-FE-58 FOR FENDL-3.2 FROM JEFF-3.1.1 BY NJOY2016.60+ ON
UR elastic cross section

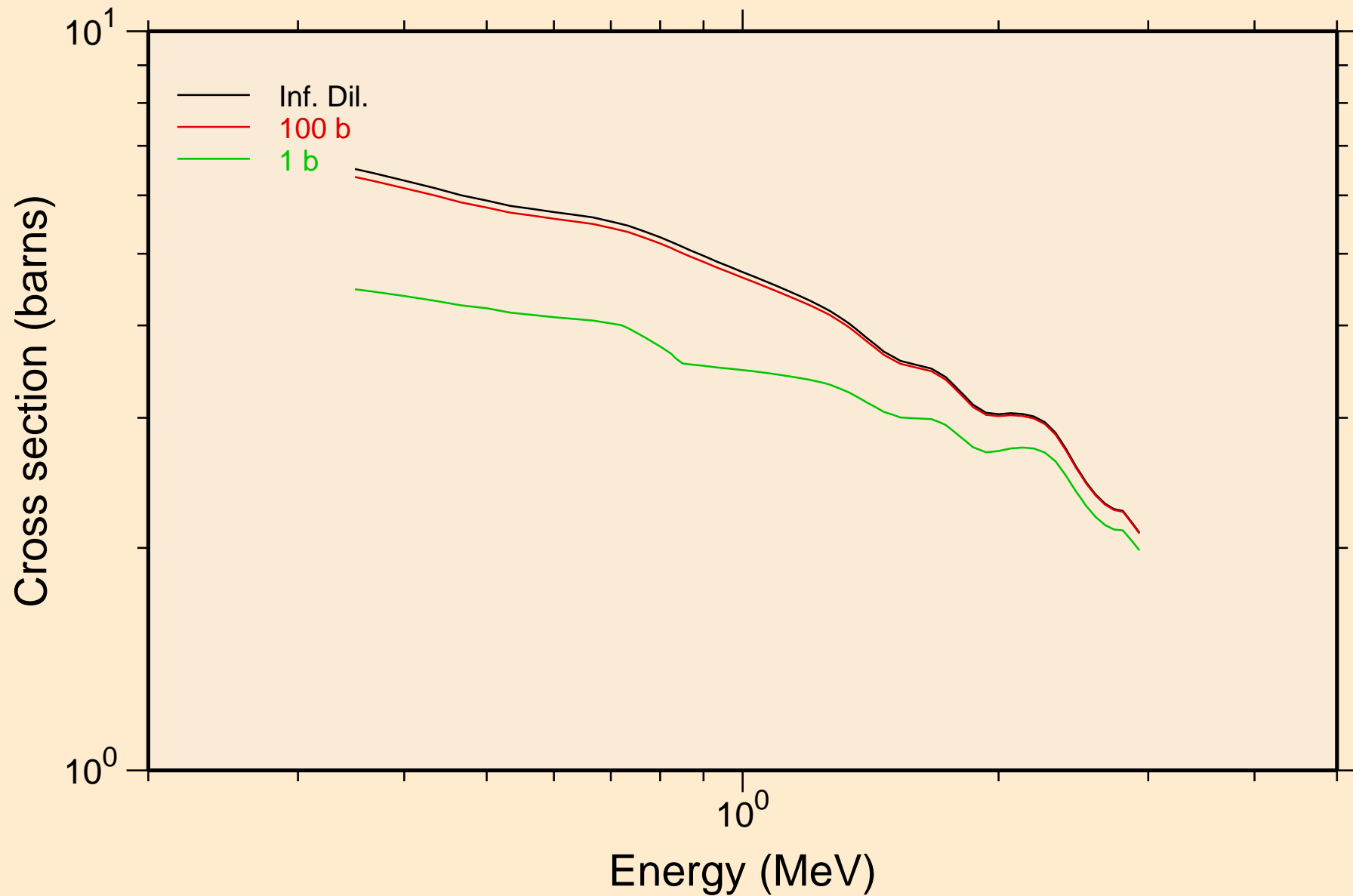

26-FE-58 FOR FENDL-3.2 FROM JEFF-3.1.1 BY NJOY2016.60+ ON
UR capture cross section

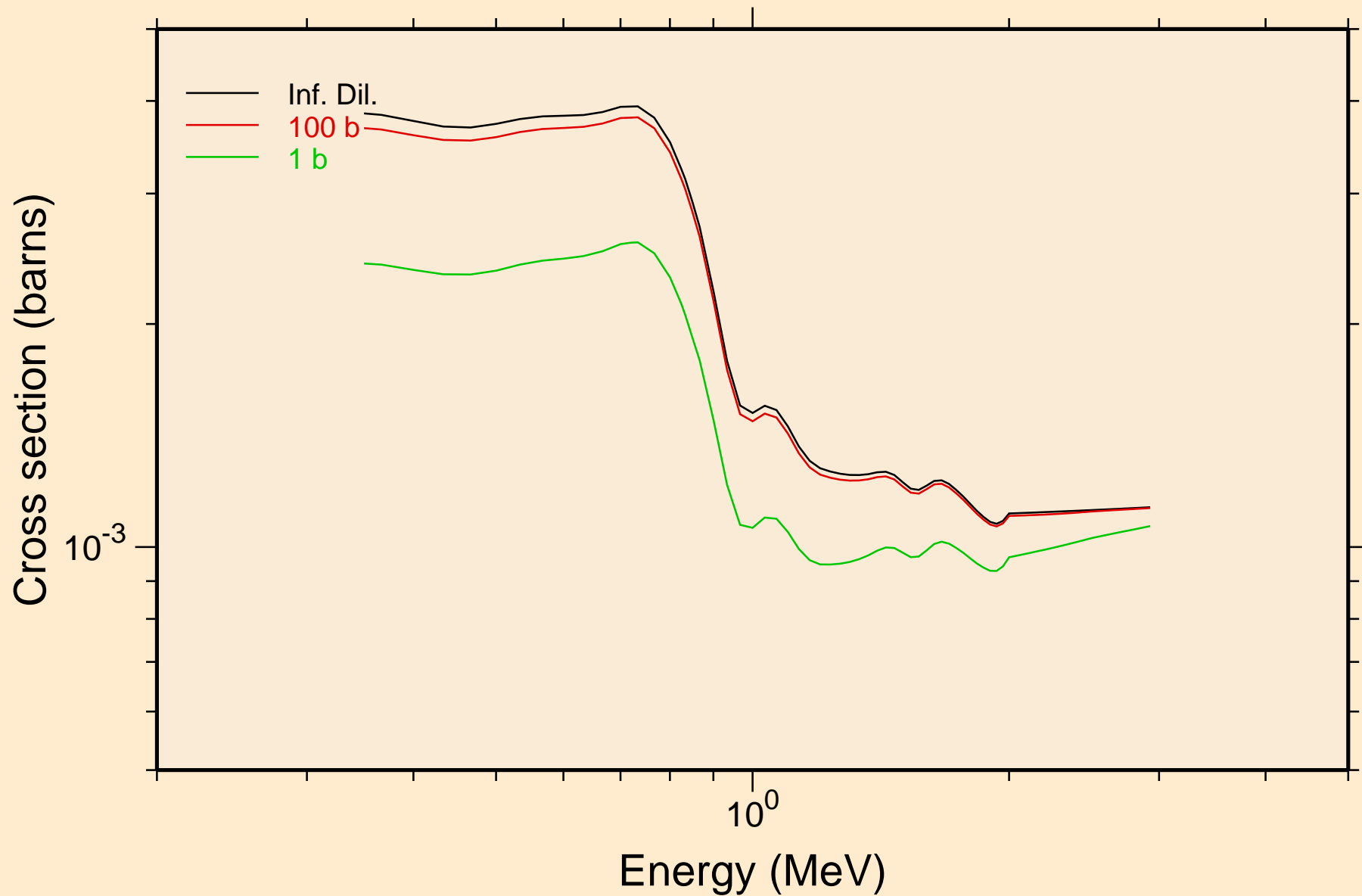

26-FE-58 FOR FENDL-3.2 FROM JEFF-3.1.1 BY NJOY2016.60+ ON Heating

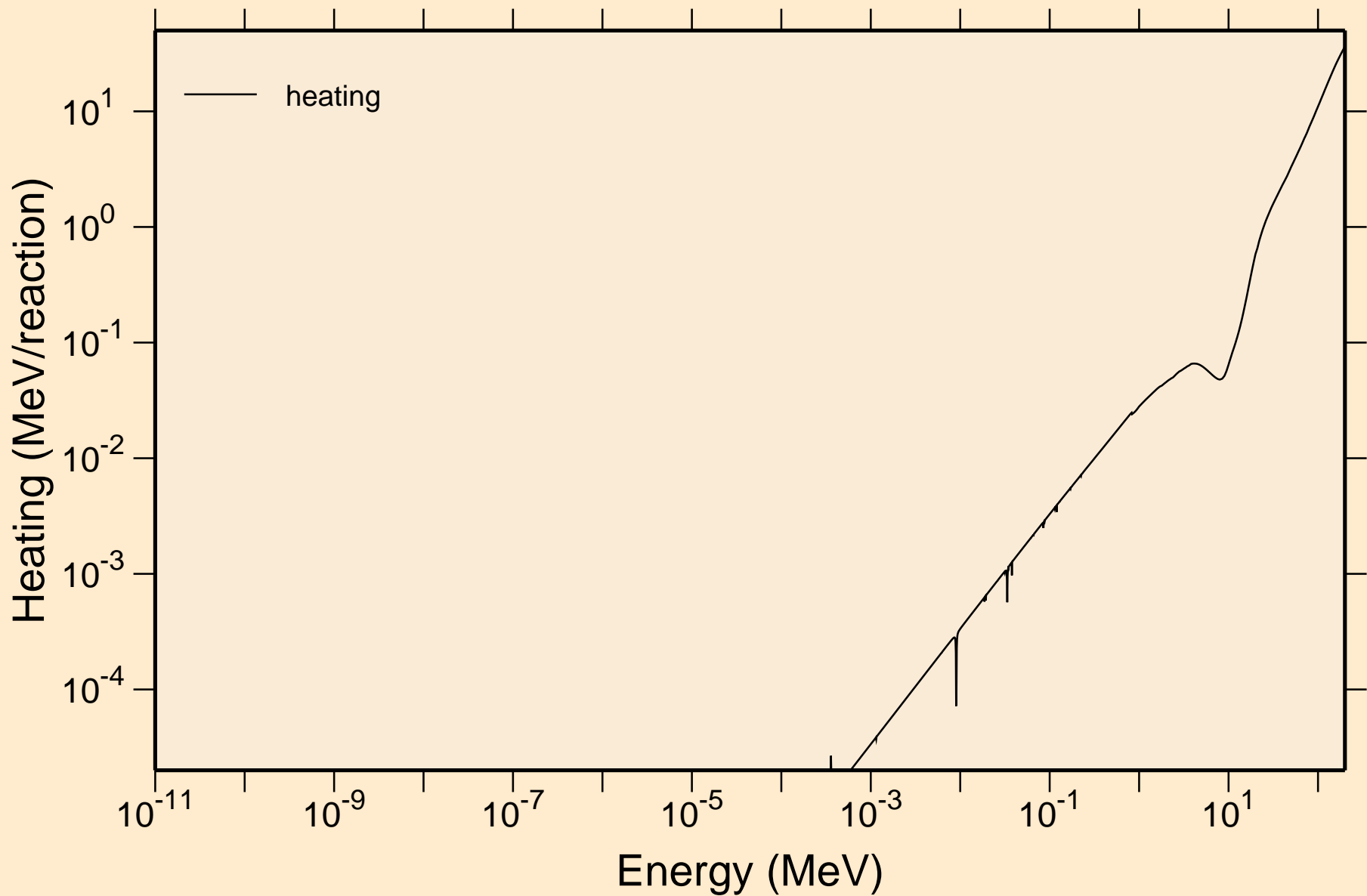

26-FE-58 FOR FENDL-3.2 FROM JEFF-3.1.1 BY NJOY2016.60+ ON Damage

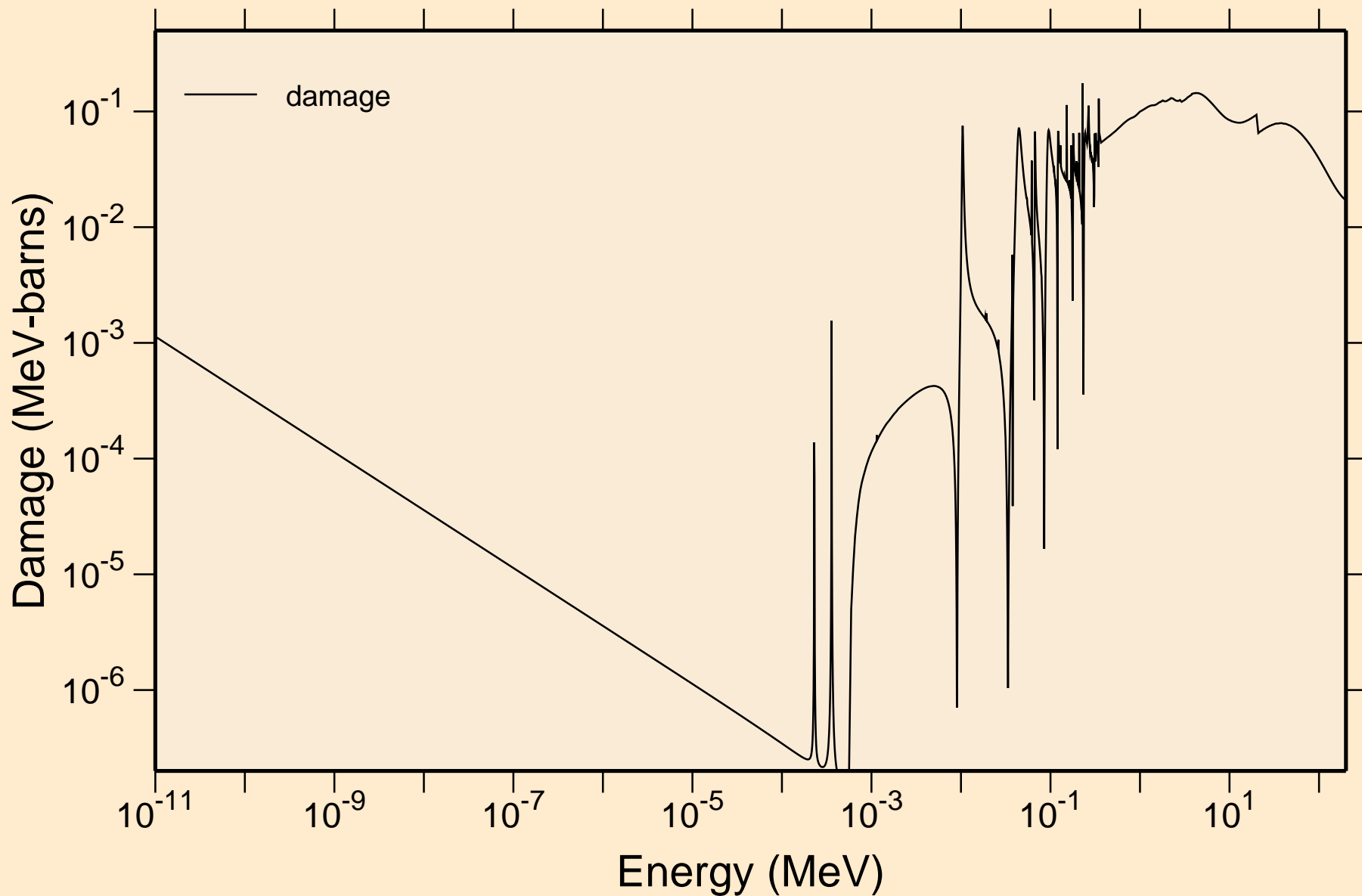

26-FE-58 FOR FENDL-3.2 FROM JEFF-3.1.1 BY NJOY2016.60+ ON
Non-threshold reactions

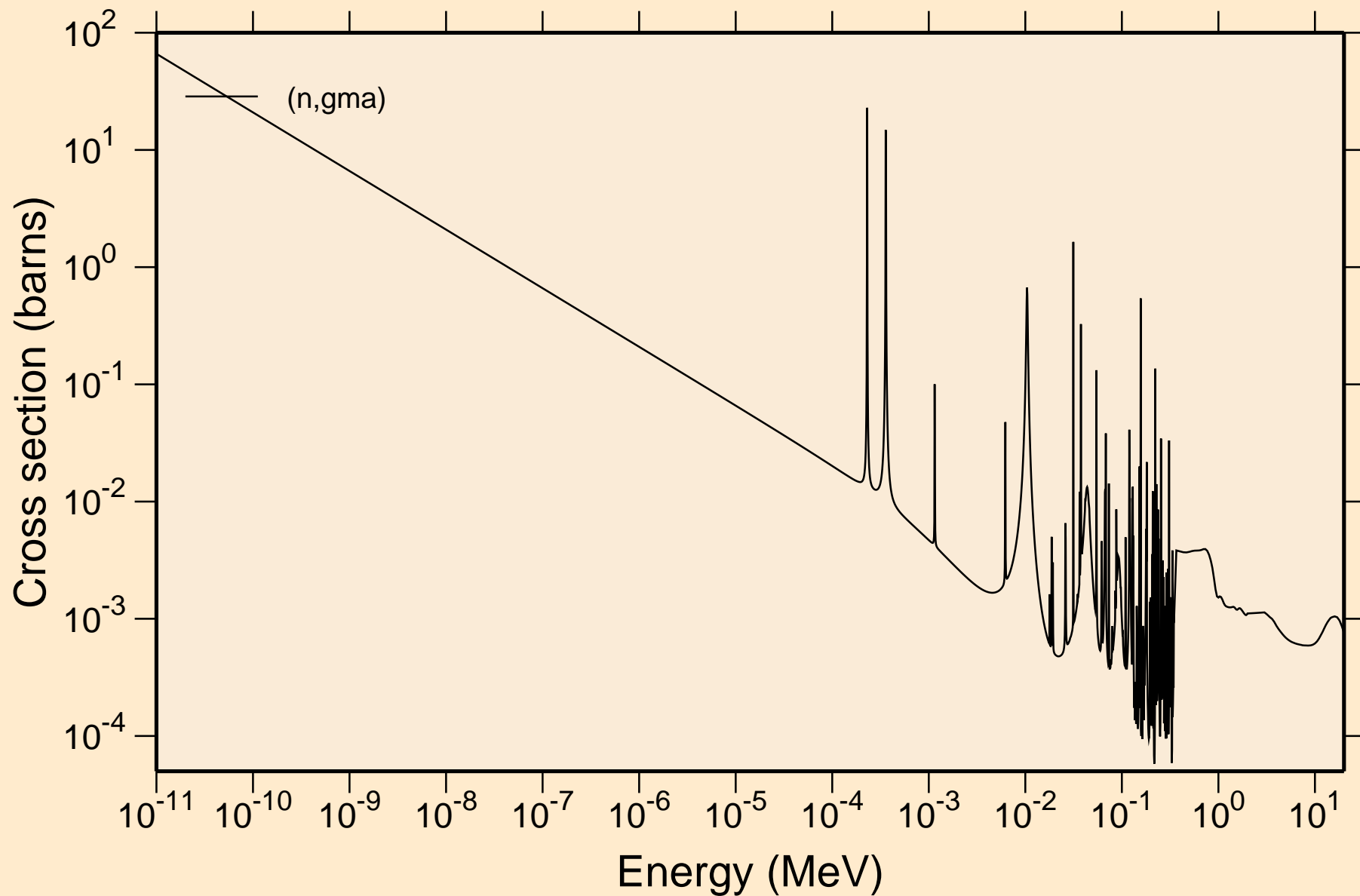

26-FE-58 FOR FENDL-3.2 FROM JEFF-3.1.1 BY NJOY2016.60+ ON
Principal cross sections

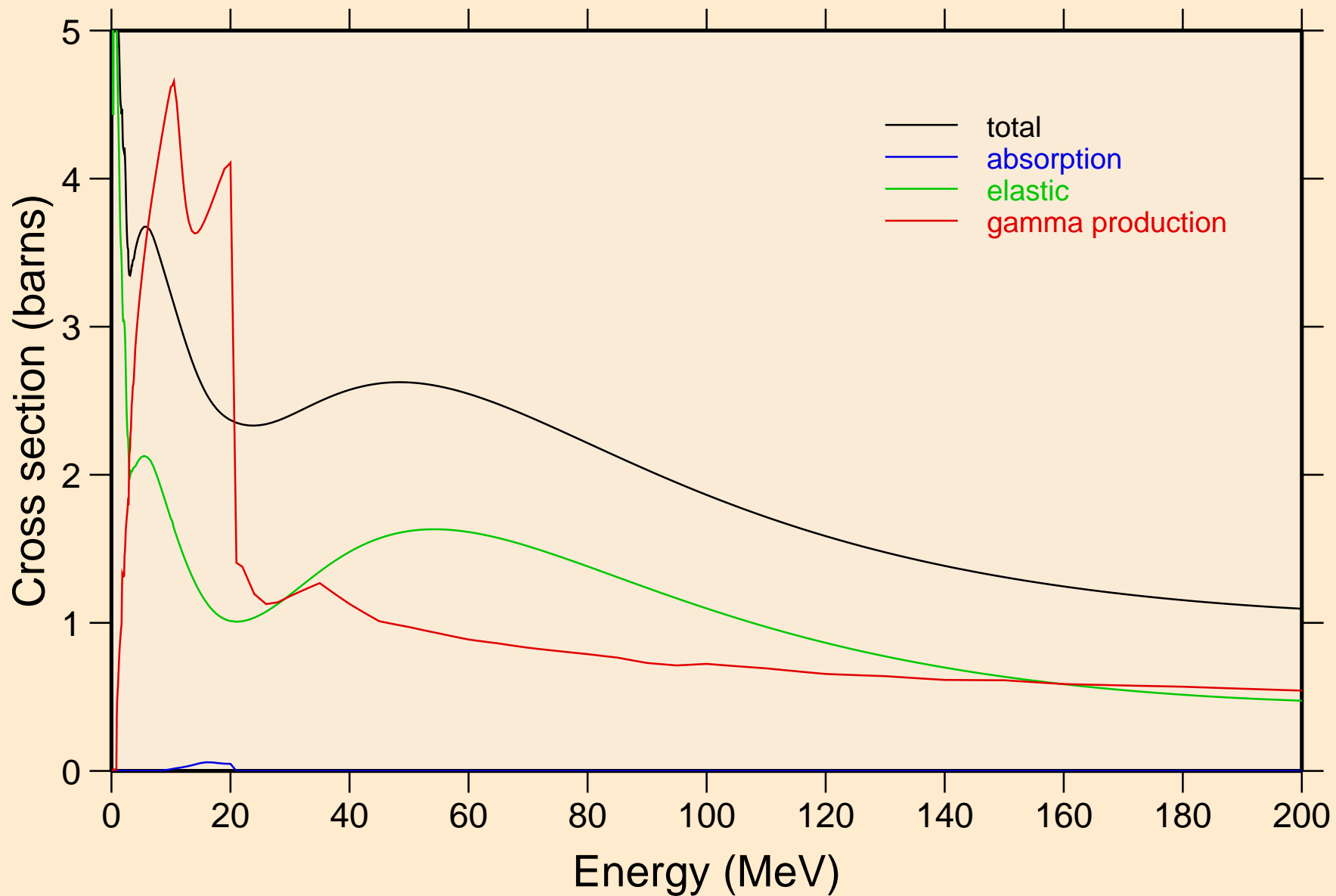

26-FE-58 FOR FENDL-3.2 FROM JEFF-3.1.1 BY NJOY2016.60+ ON Heating

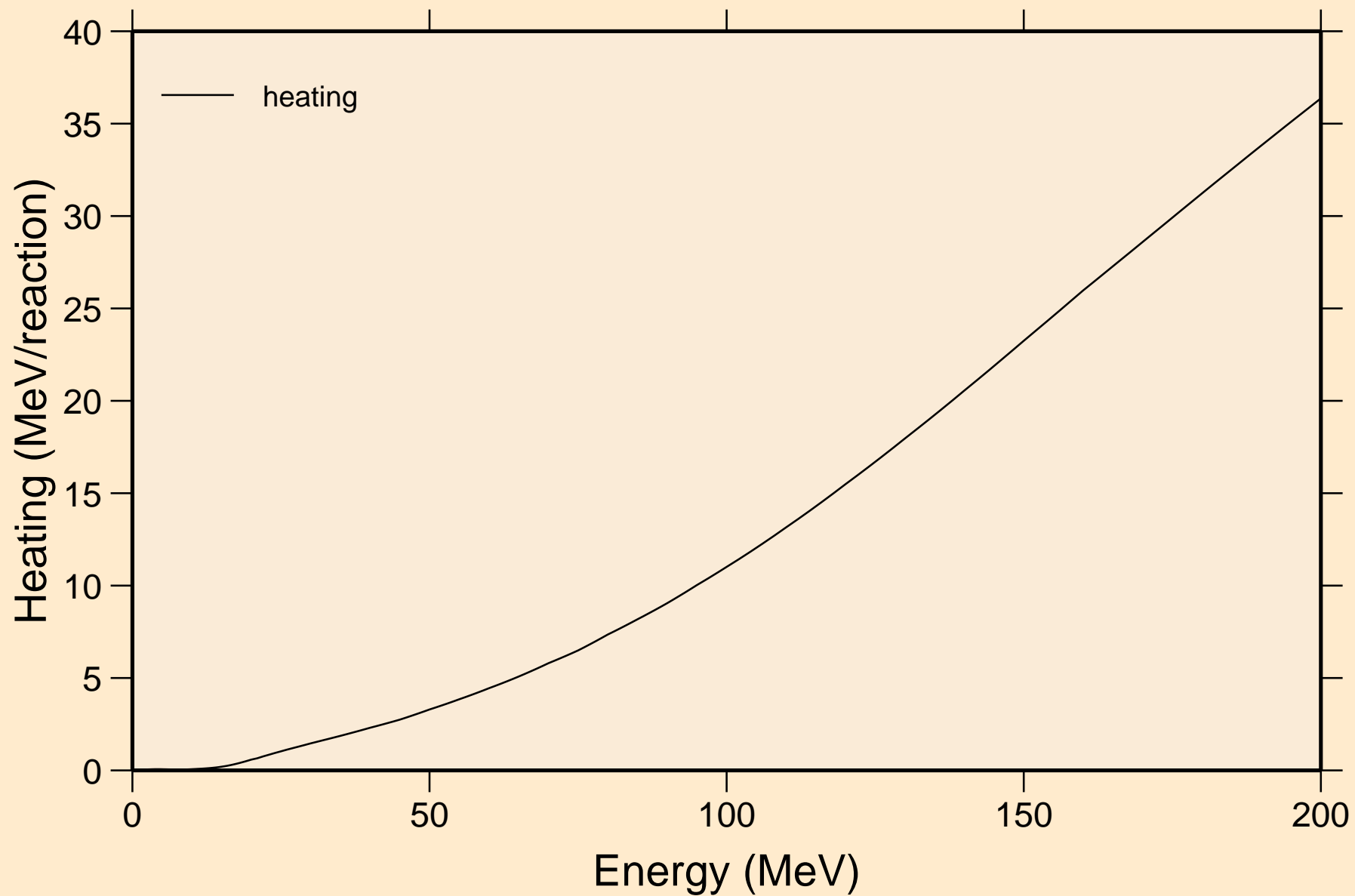

26-FE-58 FOR FENDL-3.2 FROM JEFF-3.1.1 BY NJOY2016.60+ ON
Damage

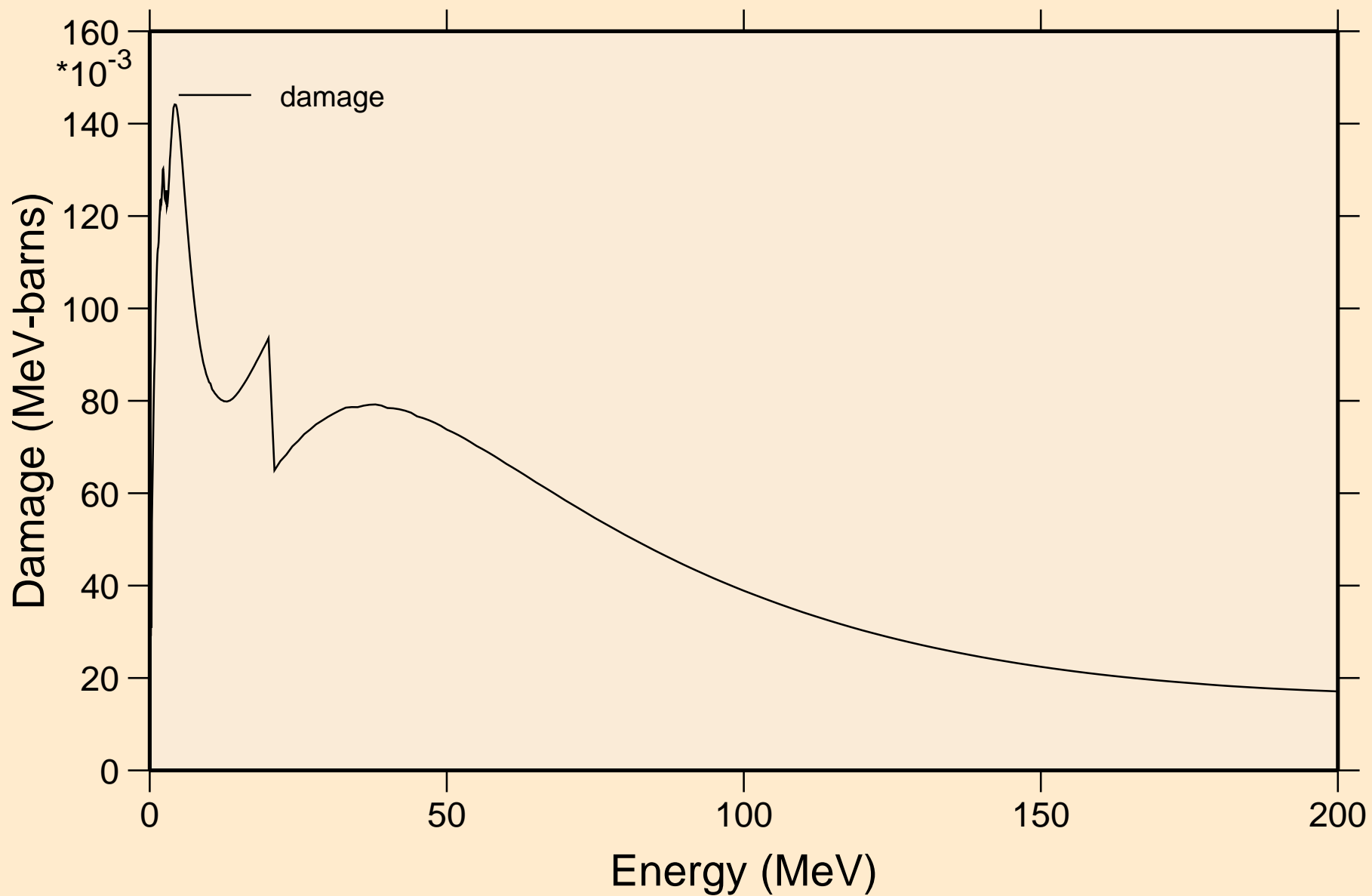

26-FE-58 FOR FENDL-3.2 FROM JEFF-3.1.1 BY NJOY2016.60+ ON
Non-threshold reactions

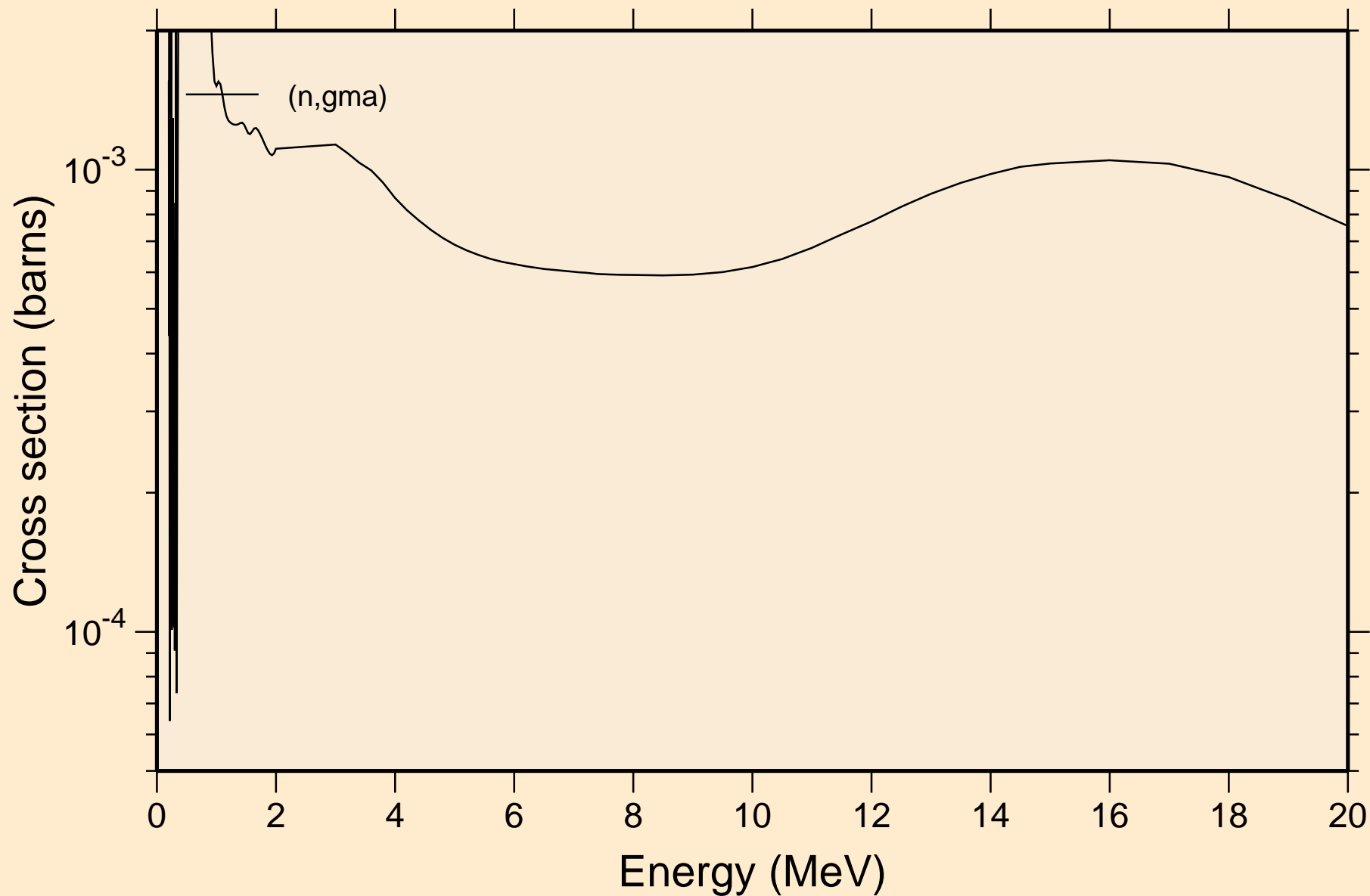

26-FE-58 FOR FENDL-3.2 FROM JEFF-3.1.1 BY NJOY2016.60+ ON
Inelastic levels

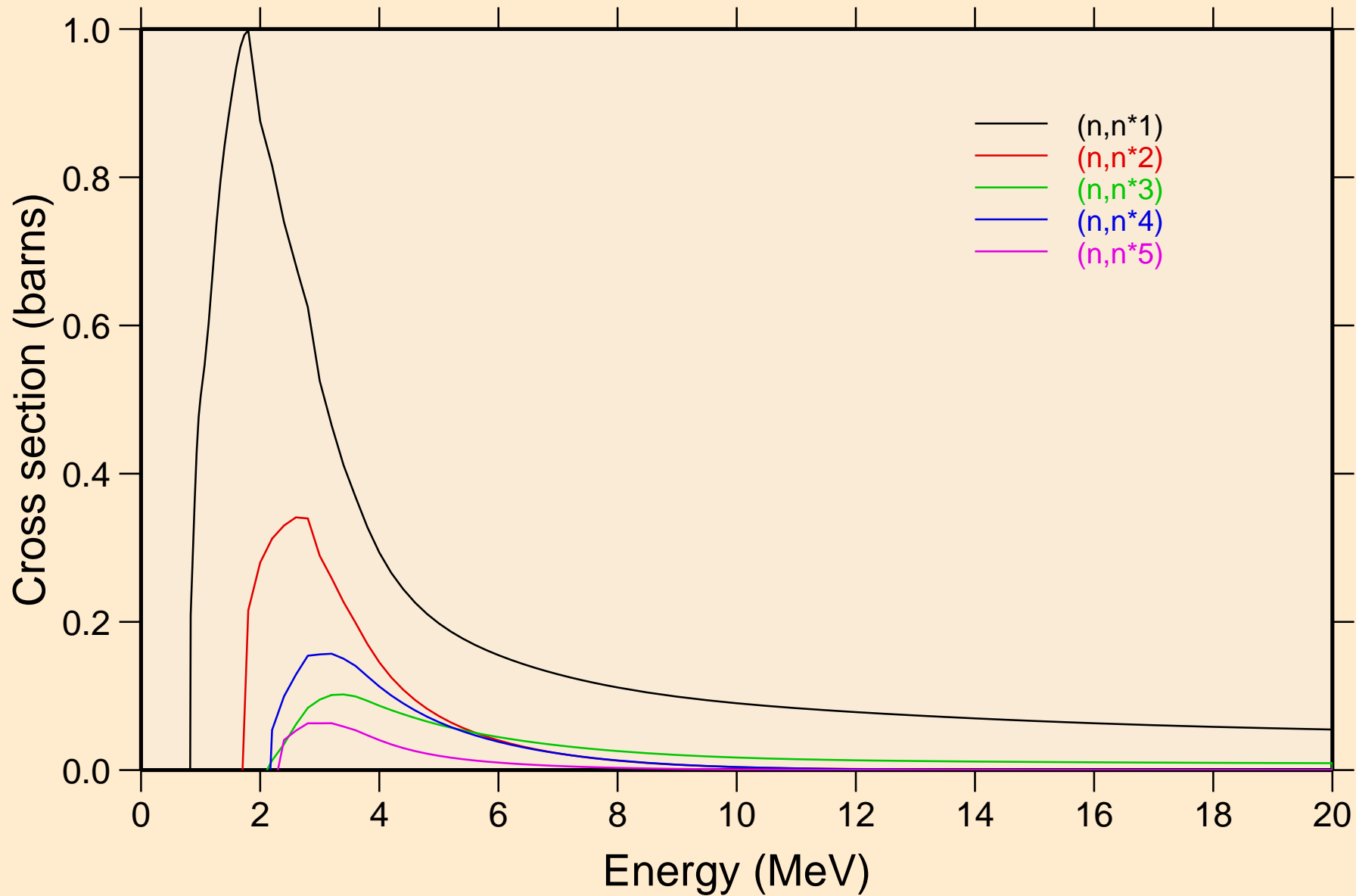

26-FE-58 FOR FENDL-3.2 FROM JEFF-3.1.1 BY NJOY2016.60+ ON
Inelastic levels

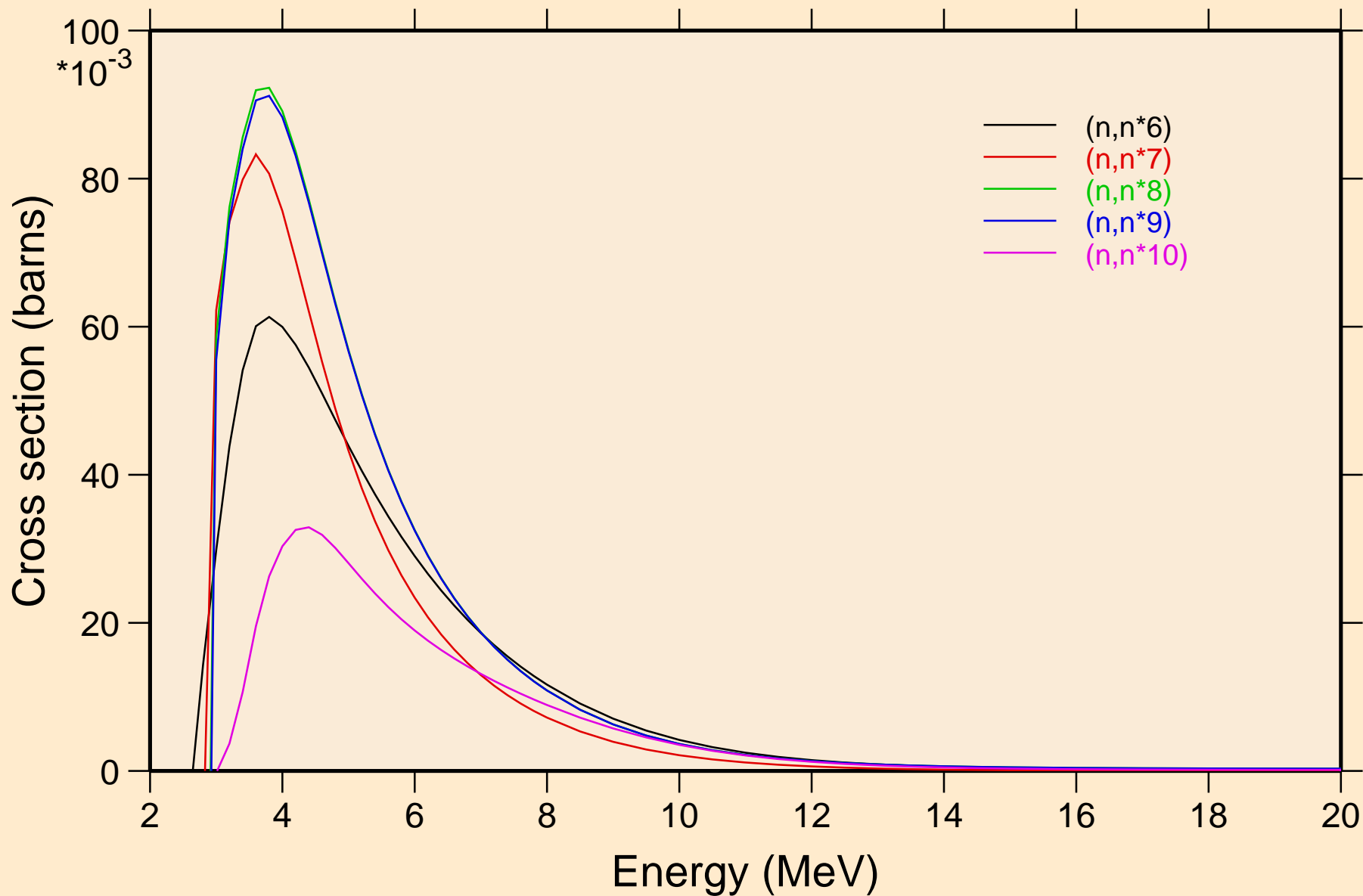

26-FE-58 FOR FENDL-3.2 FROM JEFF-3.1.1 BY NJOY2016.60+ ON Inelastic levels

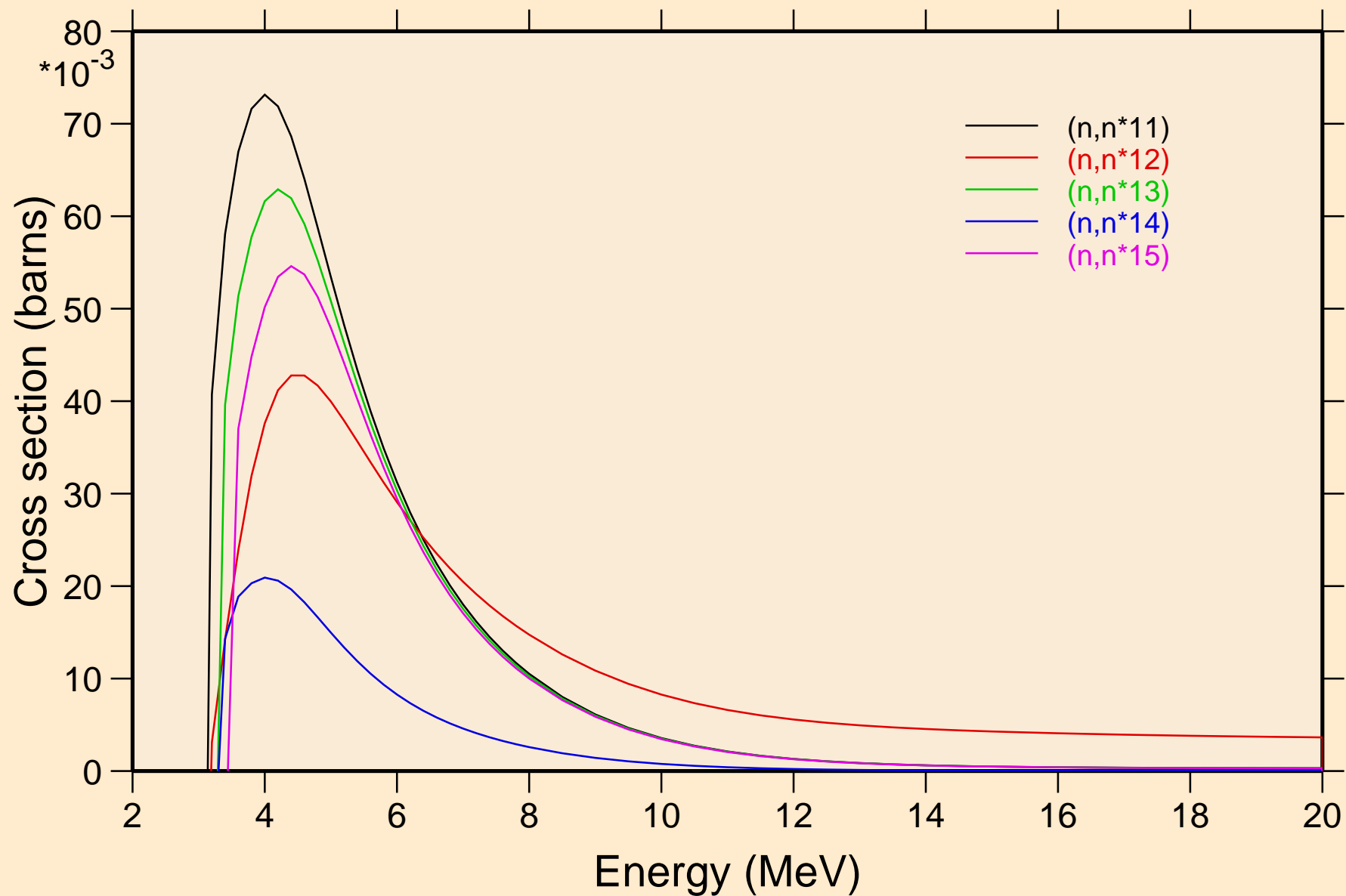

26-FE-58 FOR FENDL-3.2 FROM JEFF-3.1.1 BY NJOY2016.60+ ON
Inelastic levels

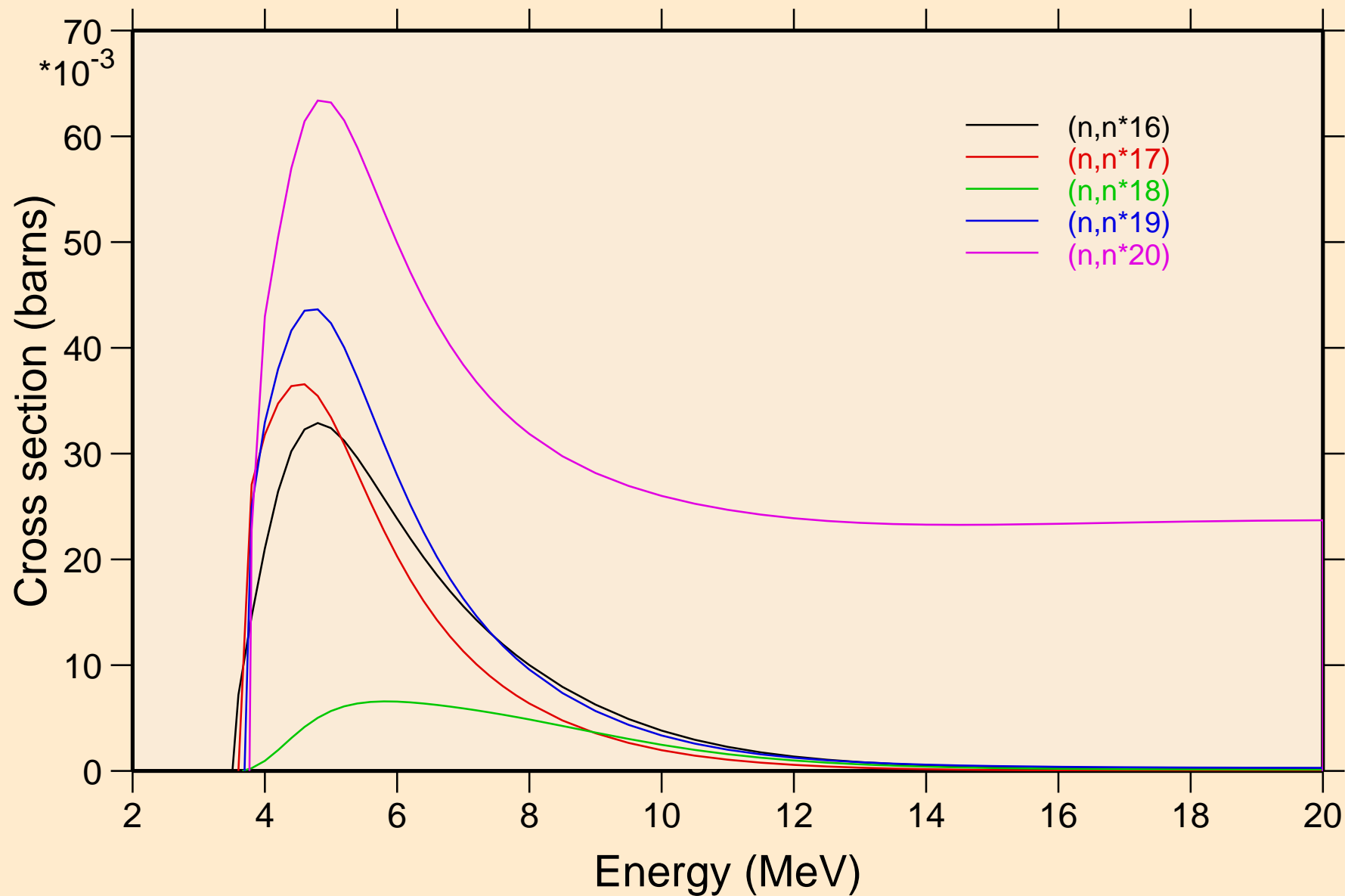

26-FE-58 FOR FENDL-3.2 FROM JEFF-3.1.1 BY NJOY2016.60+ ON
Threshold reactions

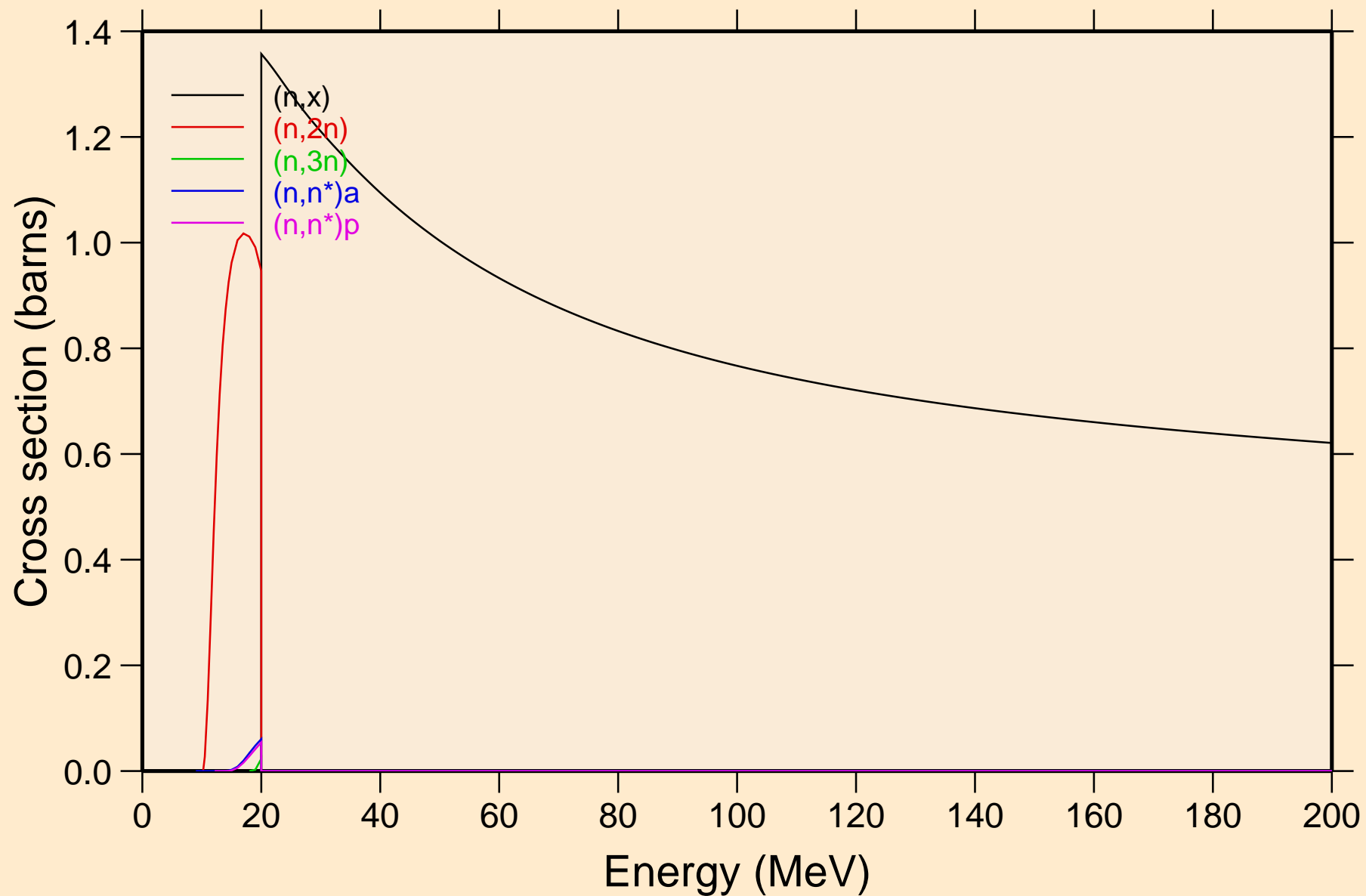

26-FE-58 FOR FENDL-3.2 FROM JEFF-3.1.1 BY NJOY2016.60+ ON
Threshold reactions

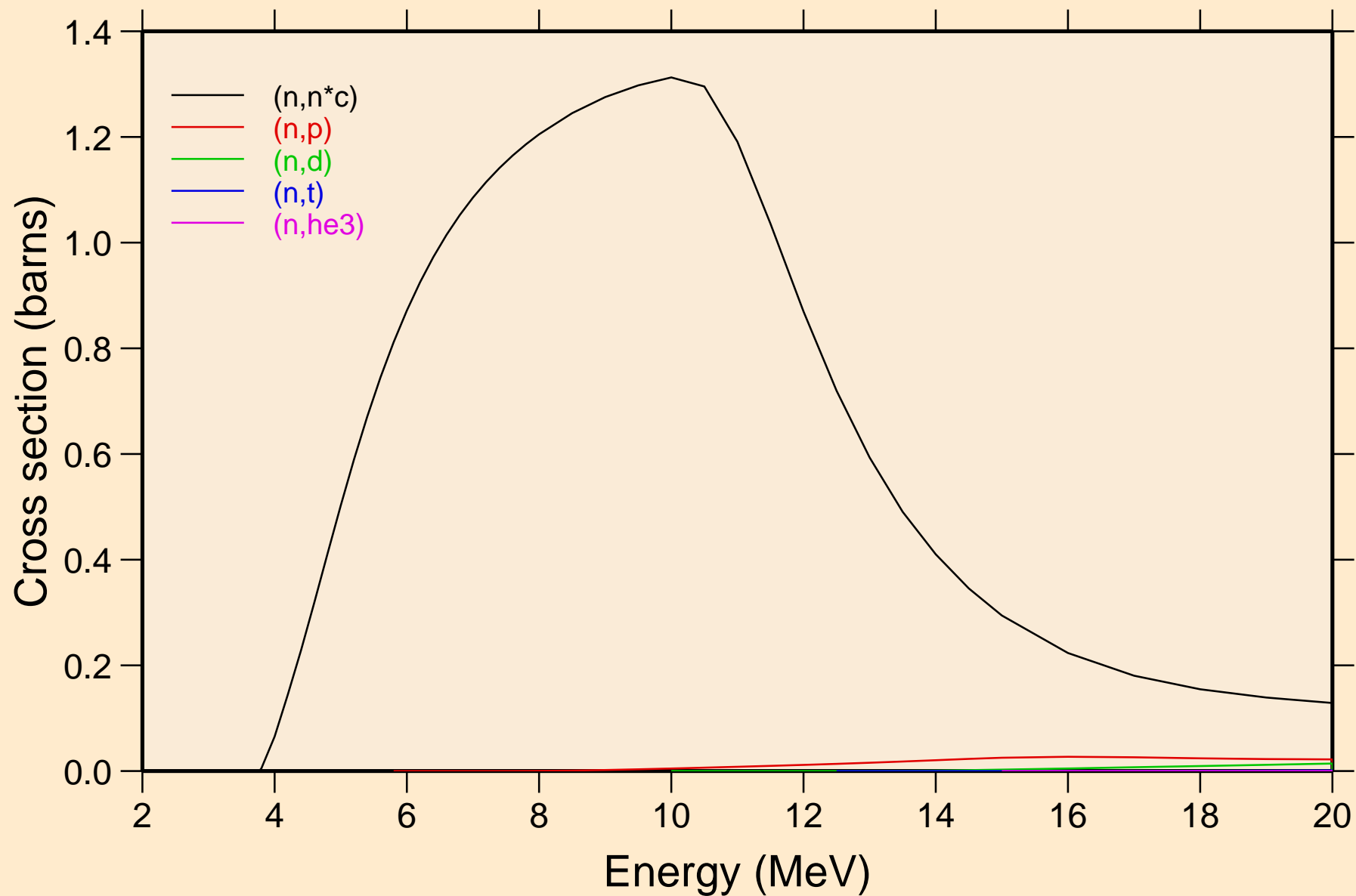

26-FE-58 FOR FENDL-3.2 FROM JEFF-3.1.1 BY NJOY2016.60+ ON
Threshold reactions

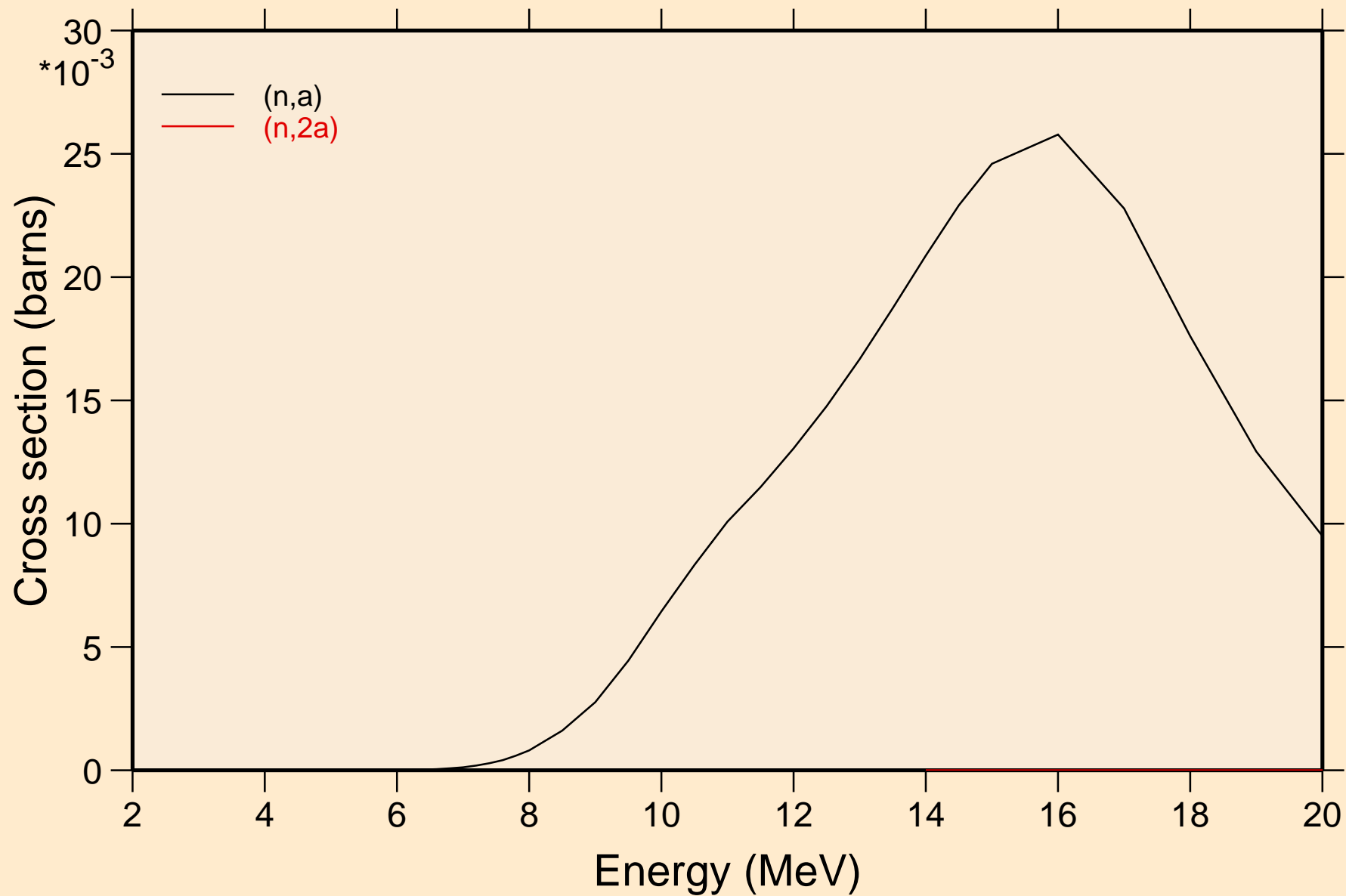

26-FE-58 FOR FENDL-3.2 FROM JEFF-3.1.1 BY NJOY2016.60+ ON
Threshold reactions

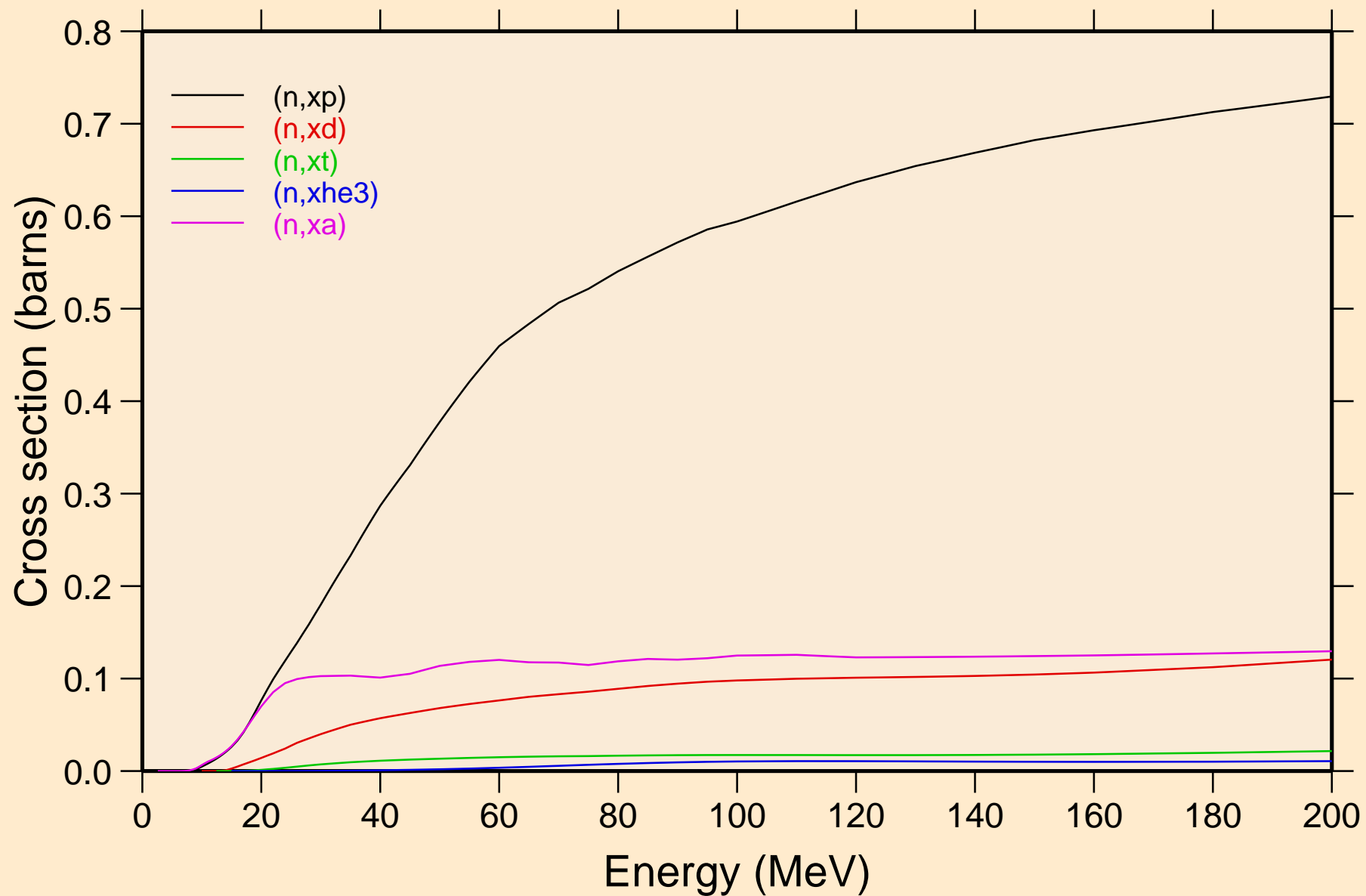

26-FE-58 FOR FENDL-3.2 FROM JEFF-3.1.1 BY NJOY2016.60+ ON
Threshold reactions

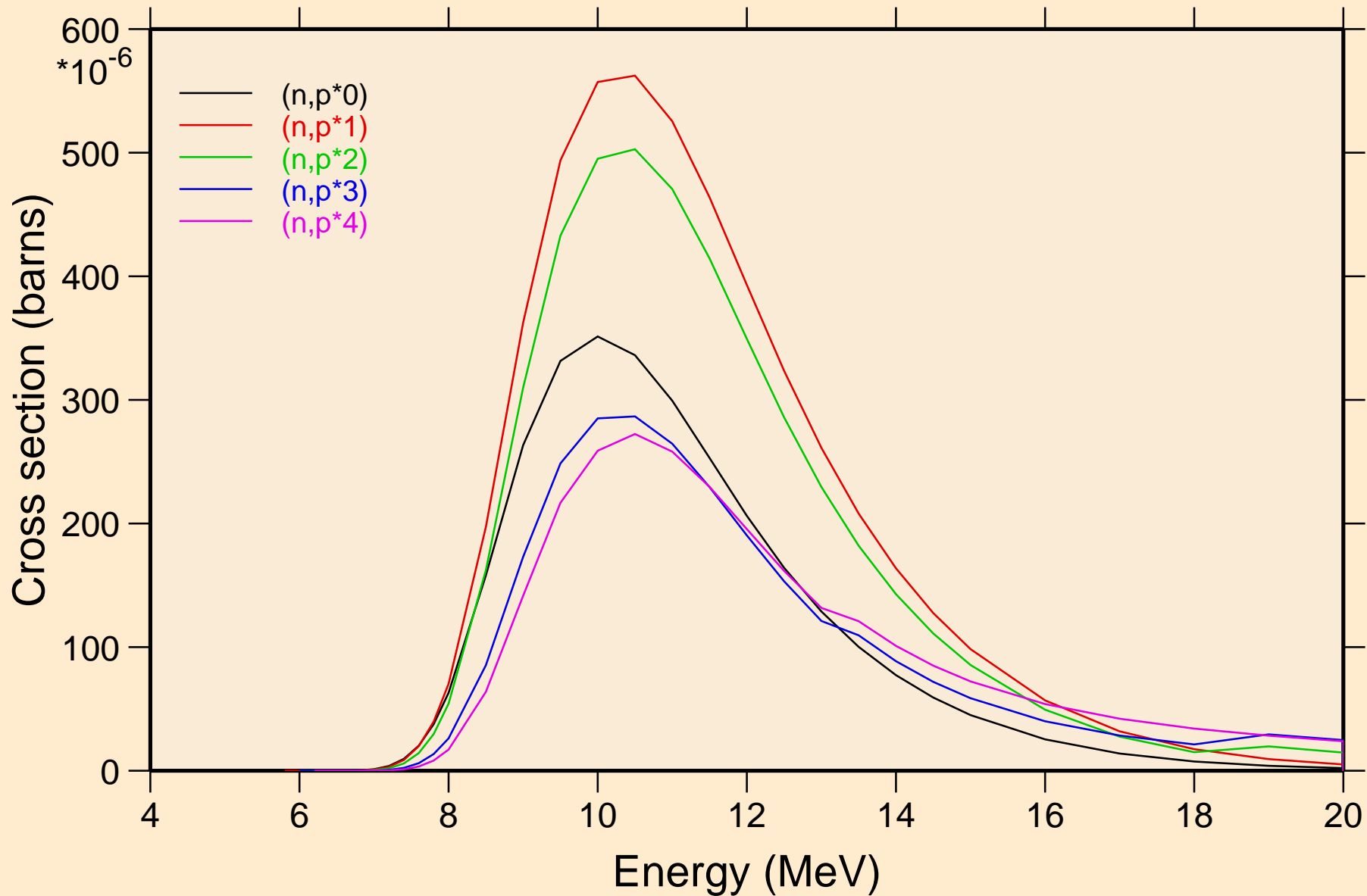

26-FE-58 FOR FENDL-3.2 FROM JEFF-3.1.1 BY NJOY2016.60+ ON
Threshold reactions

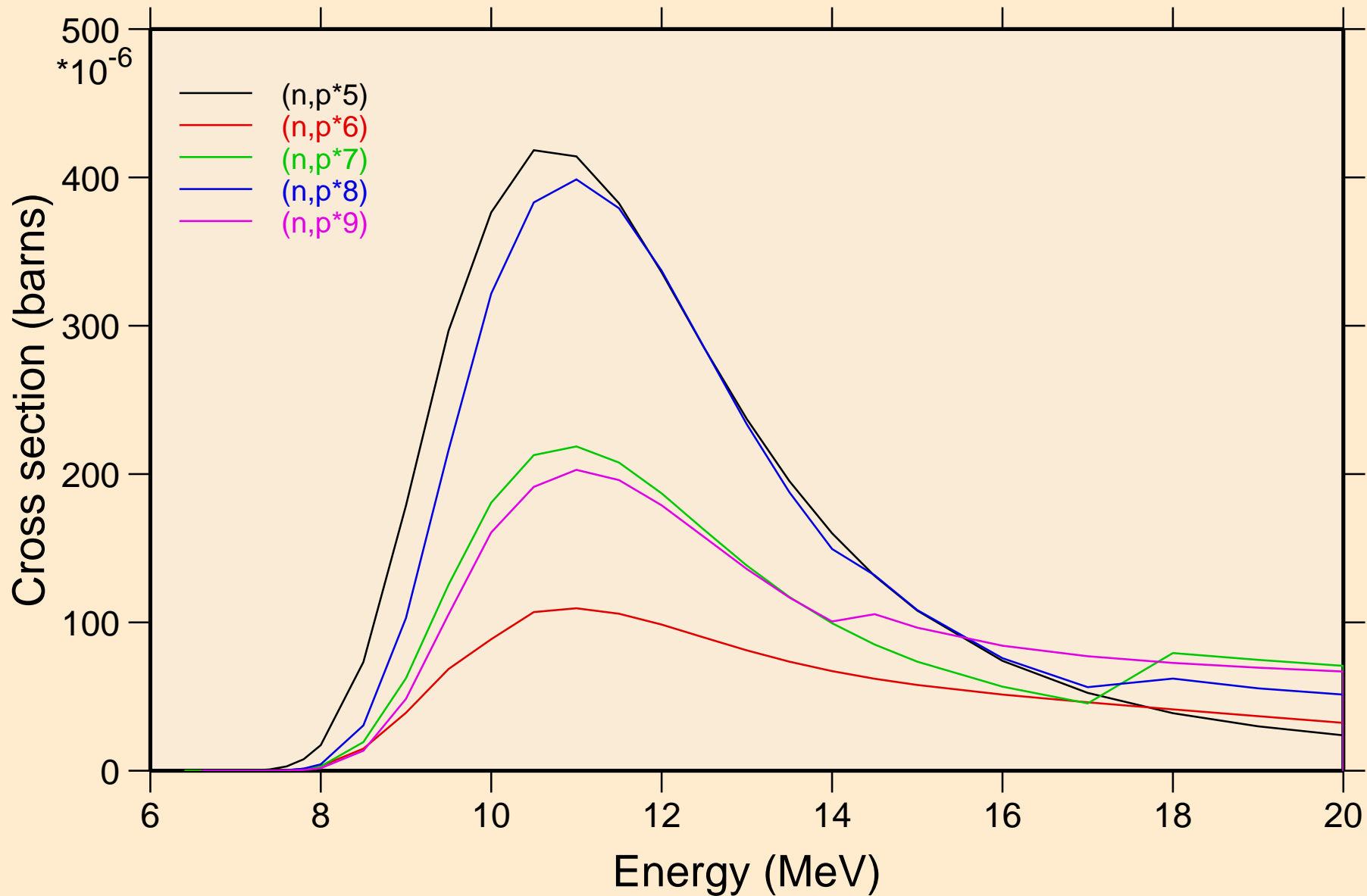

26-FE-58 FOR FENDL-3.2 FROM JEFF-3.1.1 BY NJOY2016.60+ ON
Threshold reactions

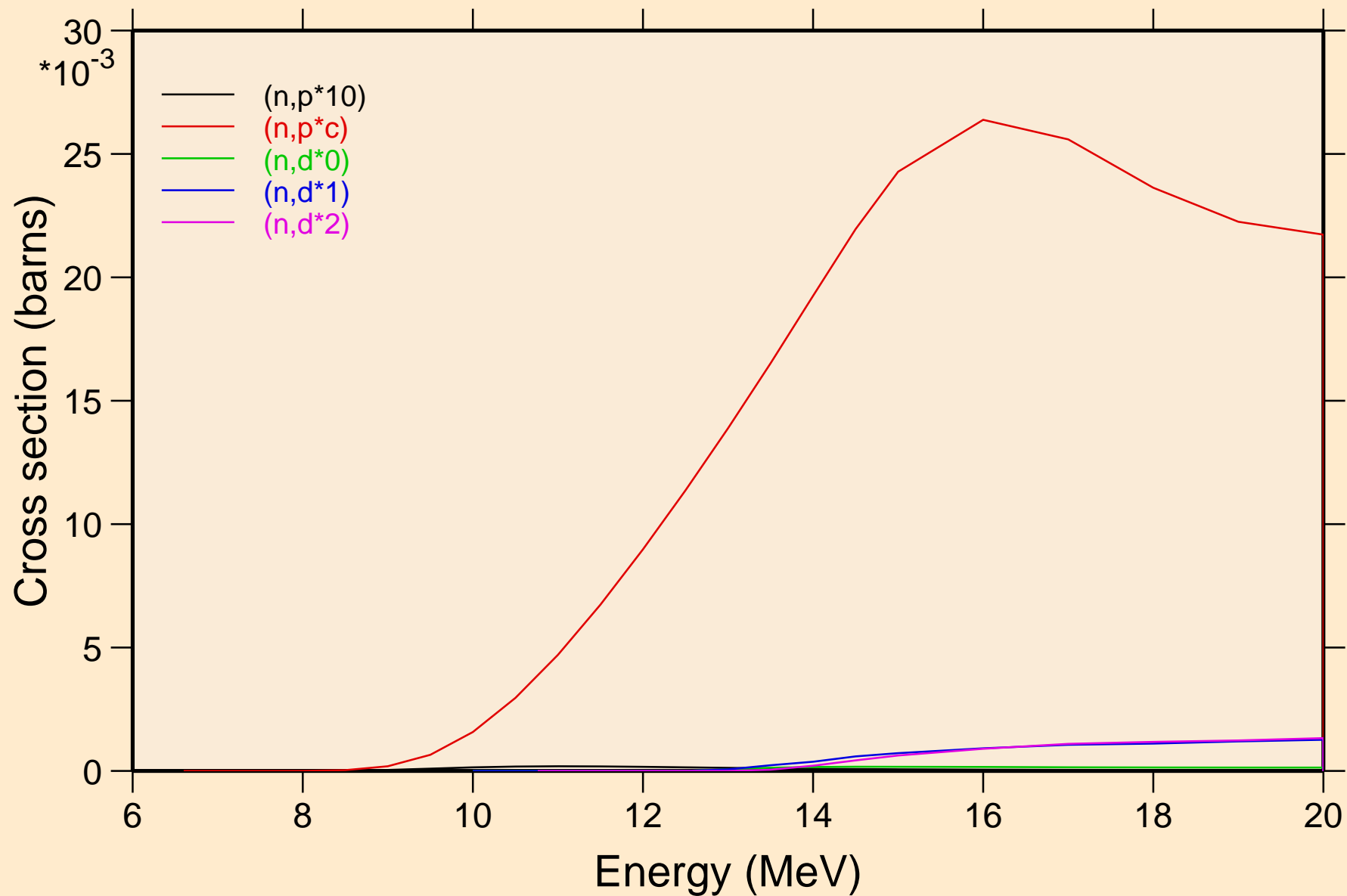

26-FE-58 FOR FENDL-3.2 FROM JEFF-3.1.1 BY NJOY2016.60+ ON
Threshold reactions

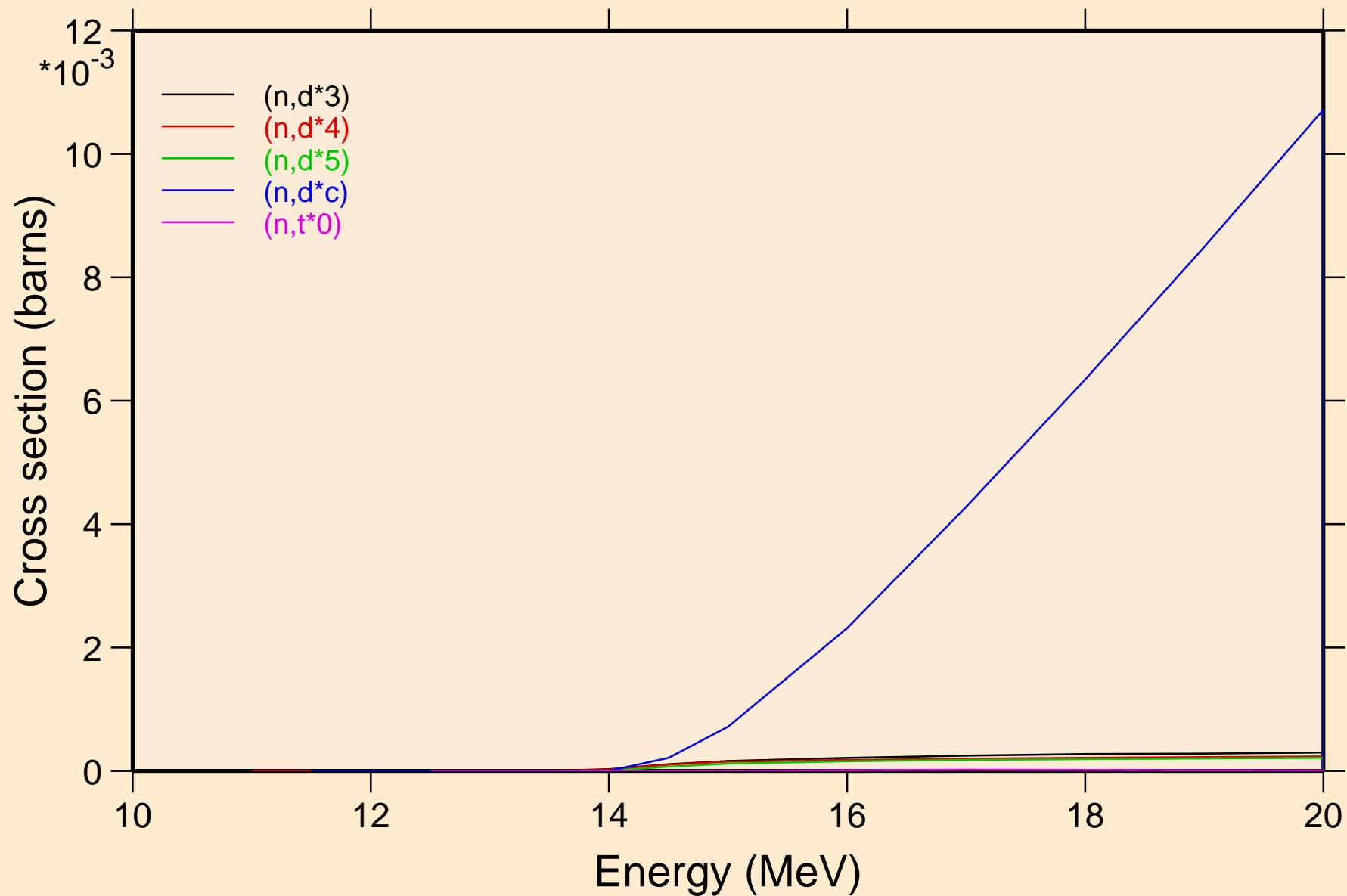

26-FE-58 FOR FENDL-3.2 FROM JEFF-3.1.1 BY NJOY2016.60+ ON
Threshold reactions

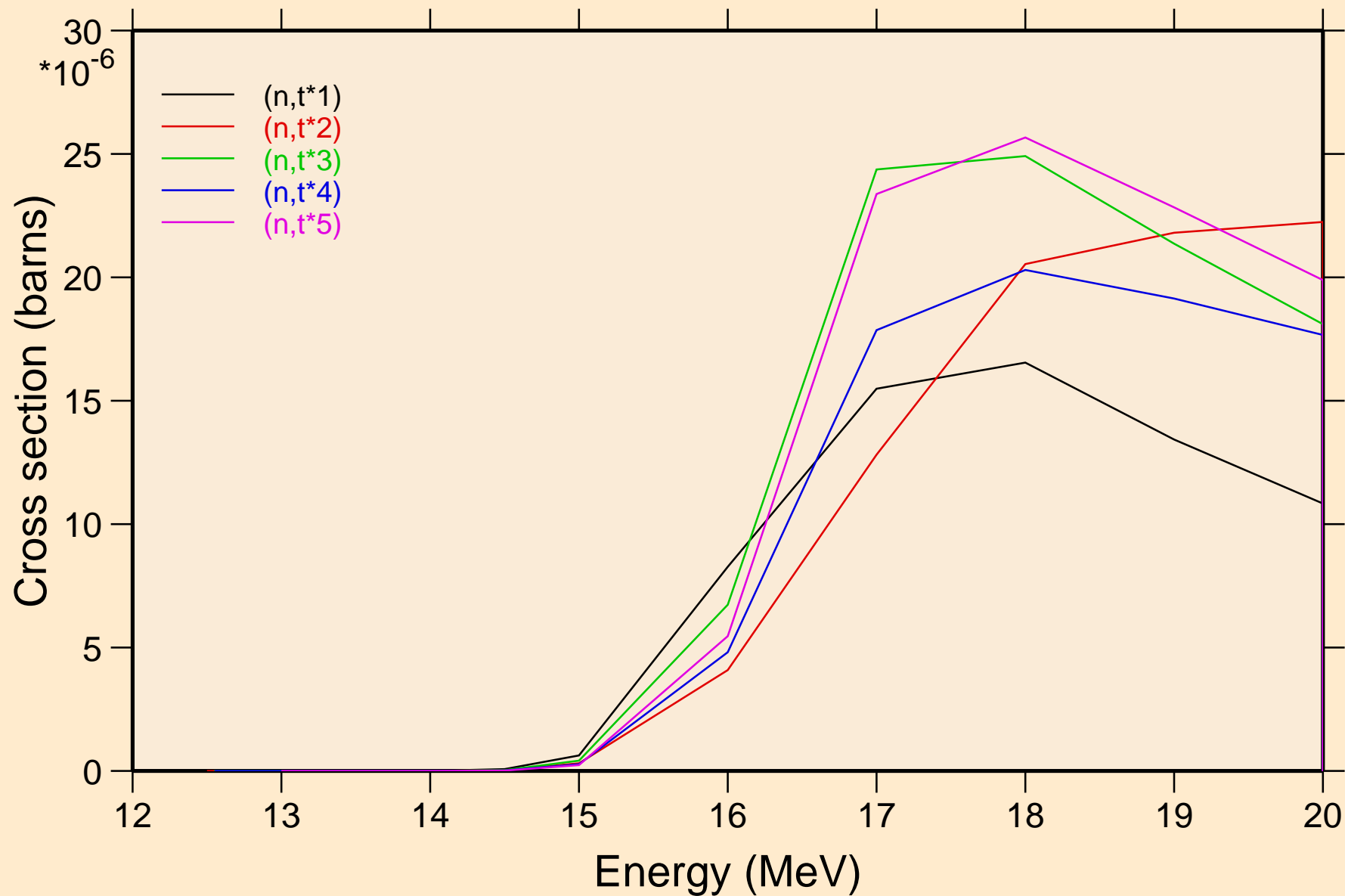

26-FE-58 FOR FENDL-3.2 FROM JEFF-3.1.1 BY NJOY2016.60+ ON
Threshold reactions

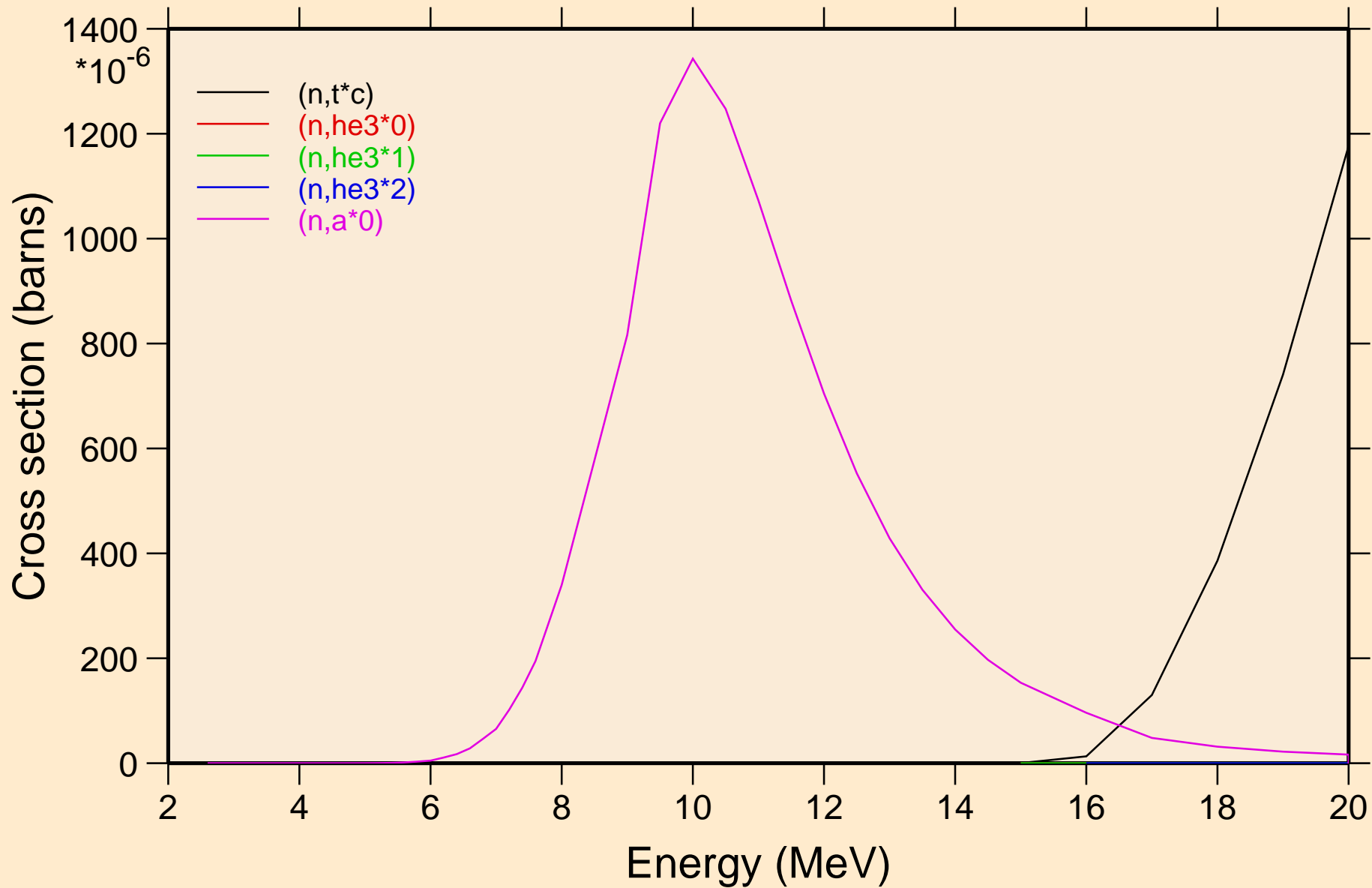

26-FE-58 FOR FENDL-3.2 FROM JEFF-3.1.1 BY NJOY2016.60+ ON
Threshold reactions

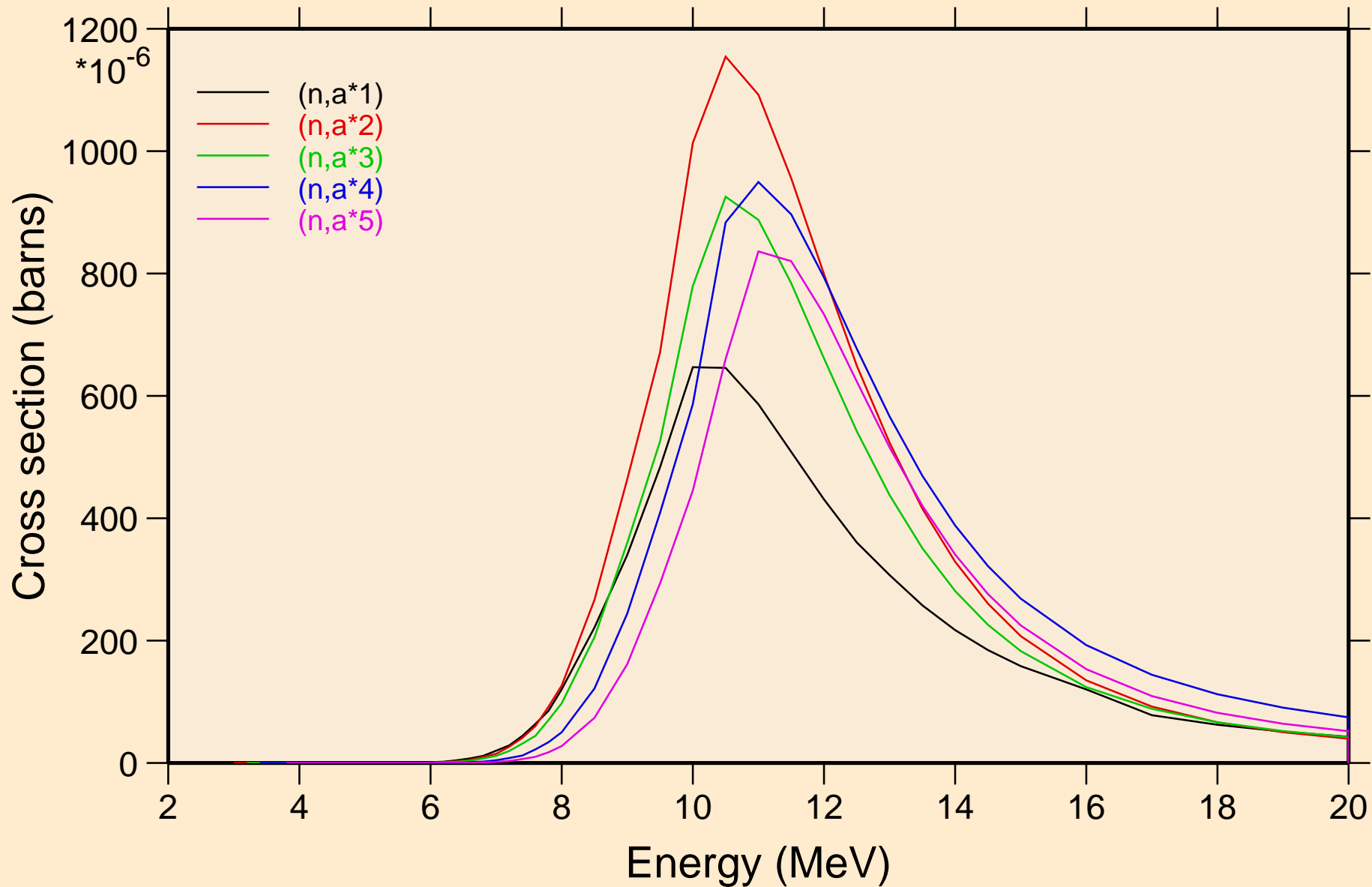

26-FE-58 FOR FENDL-3.2 FROM JEFF-3.1.1 BY NJOY2016.60+ ON
Threshold reactions

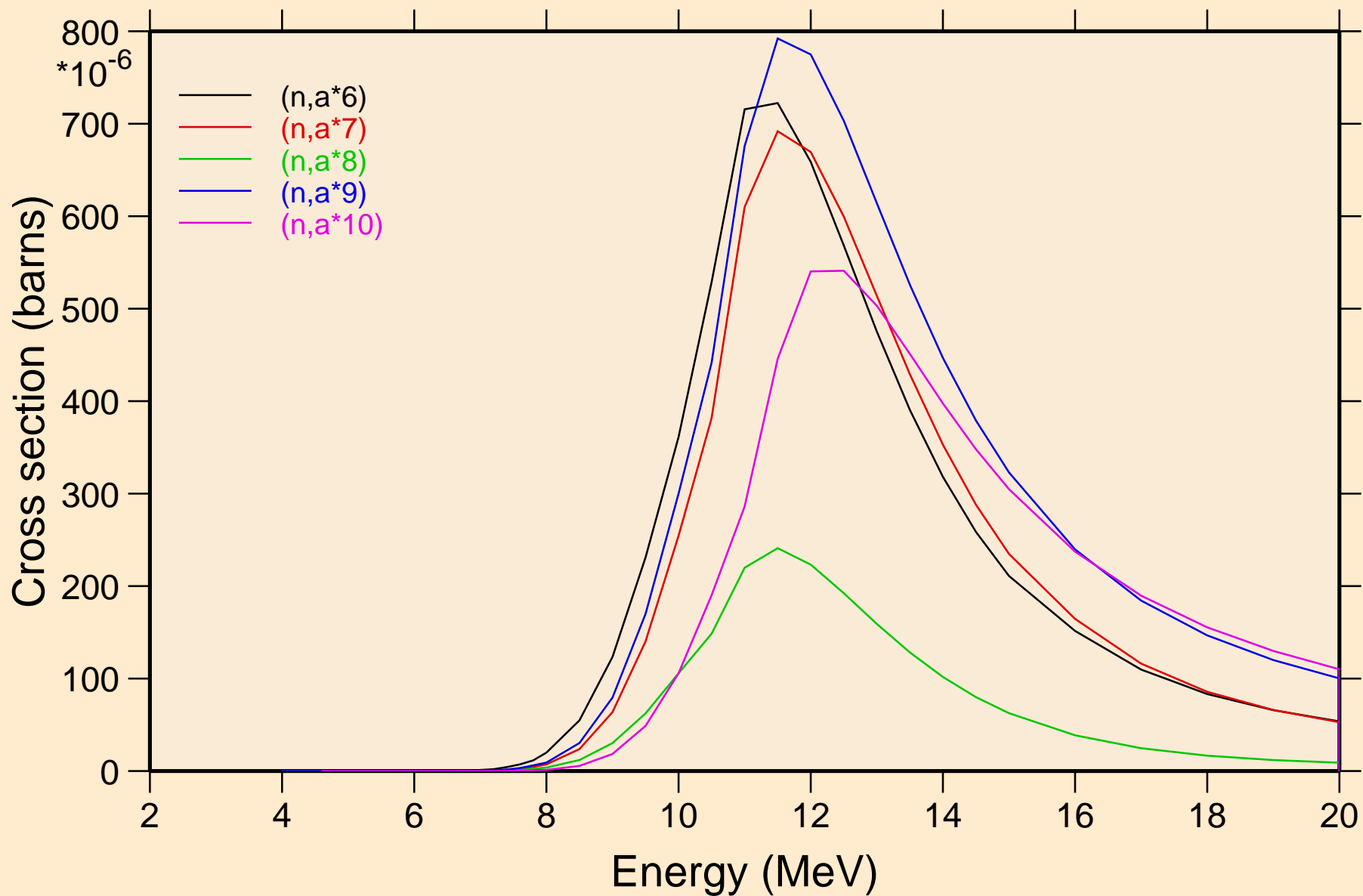

26-FE-58 FOR FENDL-3.2 FROM JEFF-3.1.1 BY NJOY2016.60+ ON
Threshold reactions

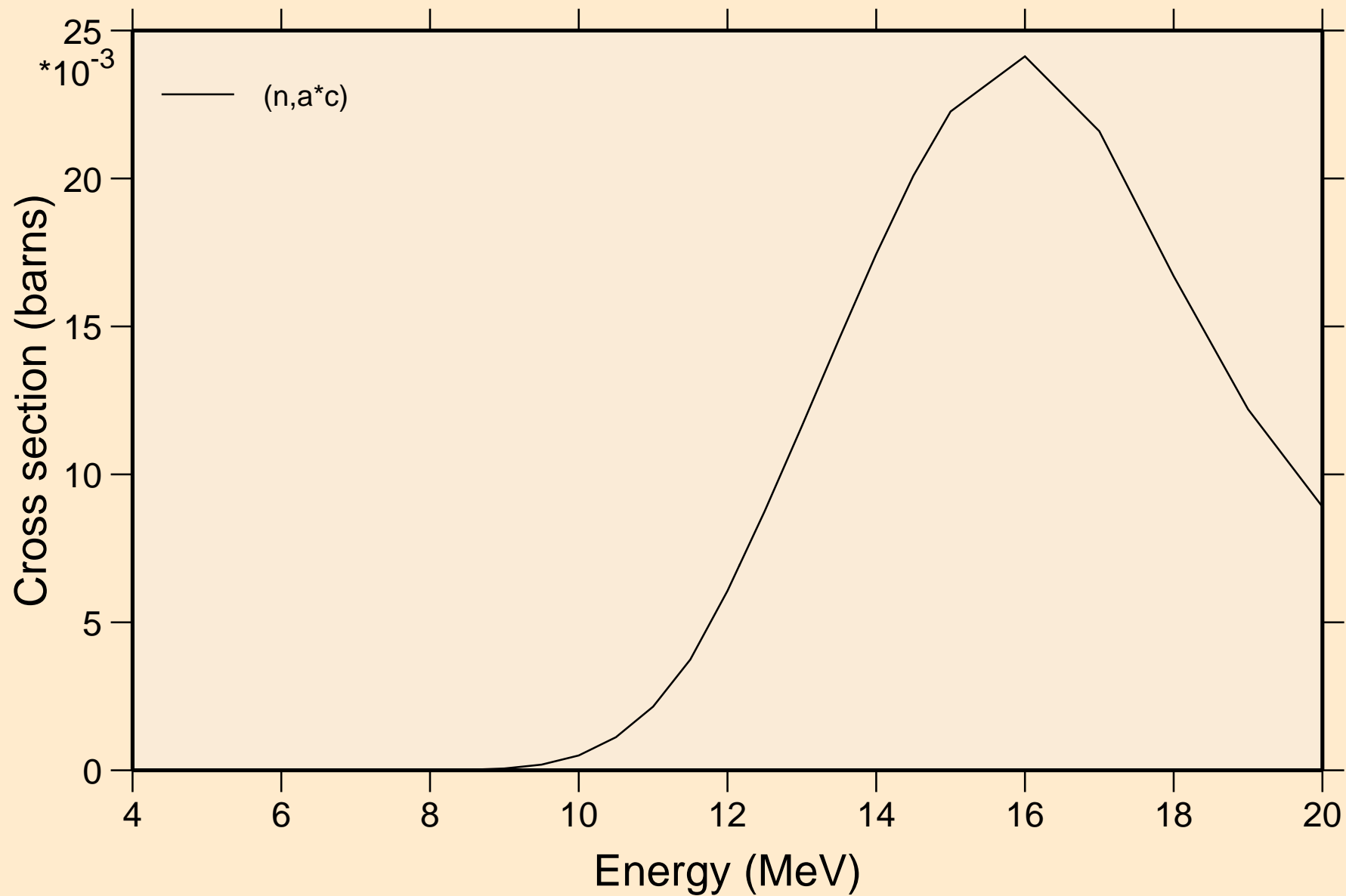

26-FE-58 FOR FENDL-3.2 FROM JEFF-3.1.1 BY NJOY2016.60+ ON
angular distribution for elastic

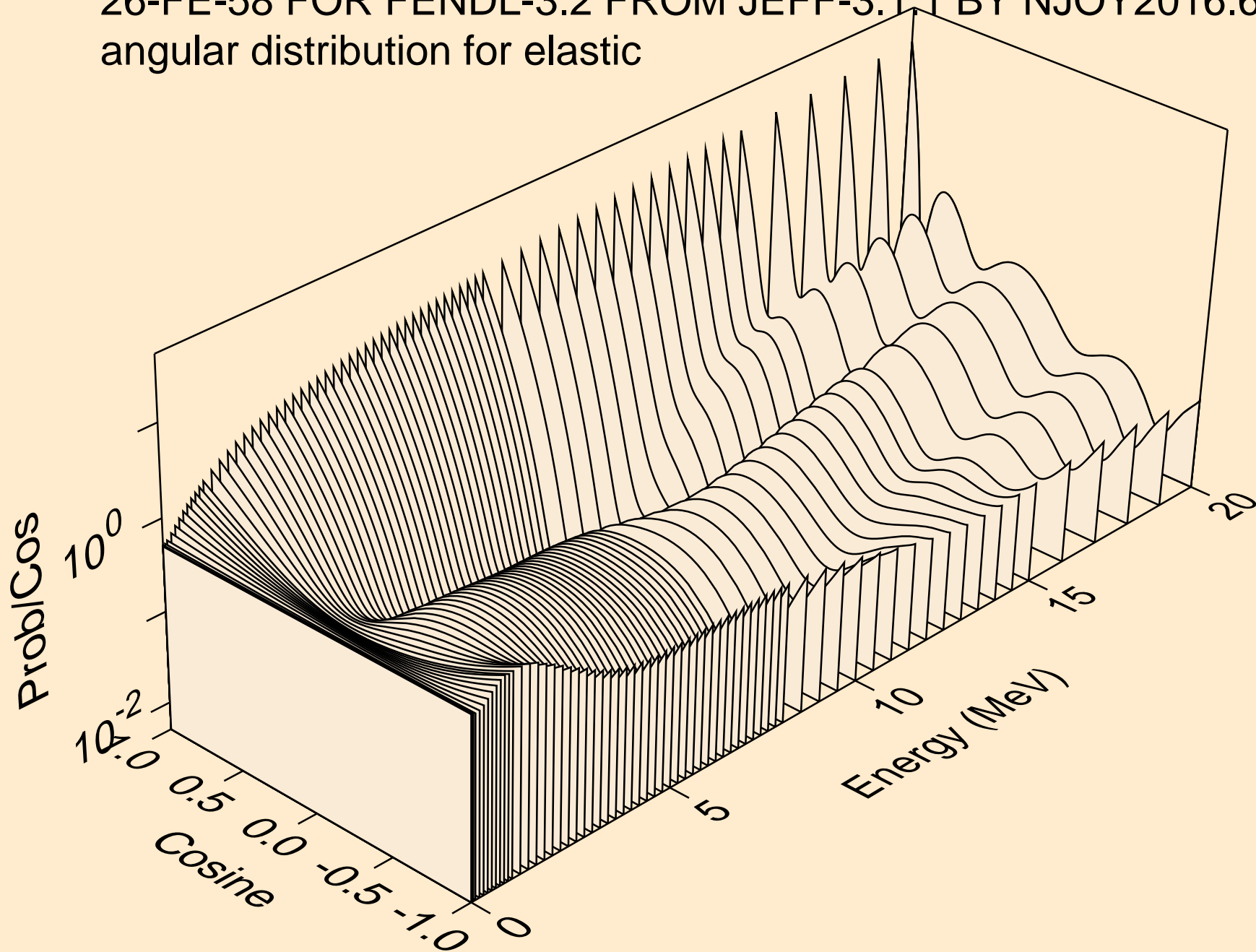

26-FE-58 FOR FENDL-3.2 FROM JEFF-3.1.1 BY NJOY2016.60+ ON
angular distribution for elastic

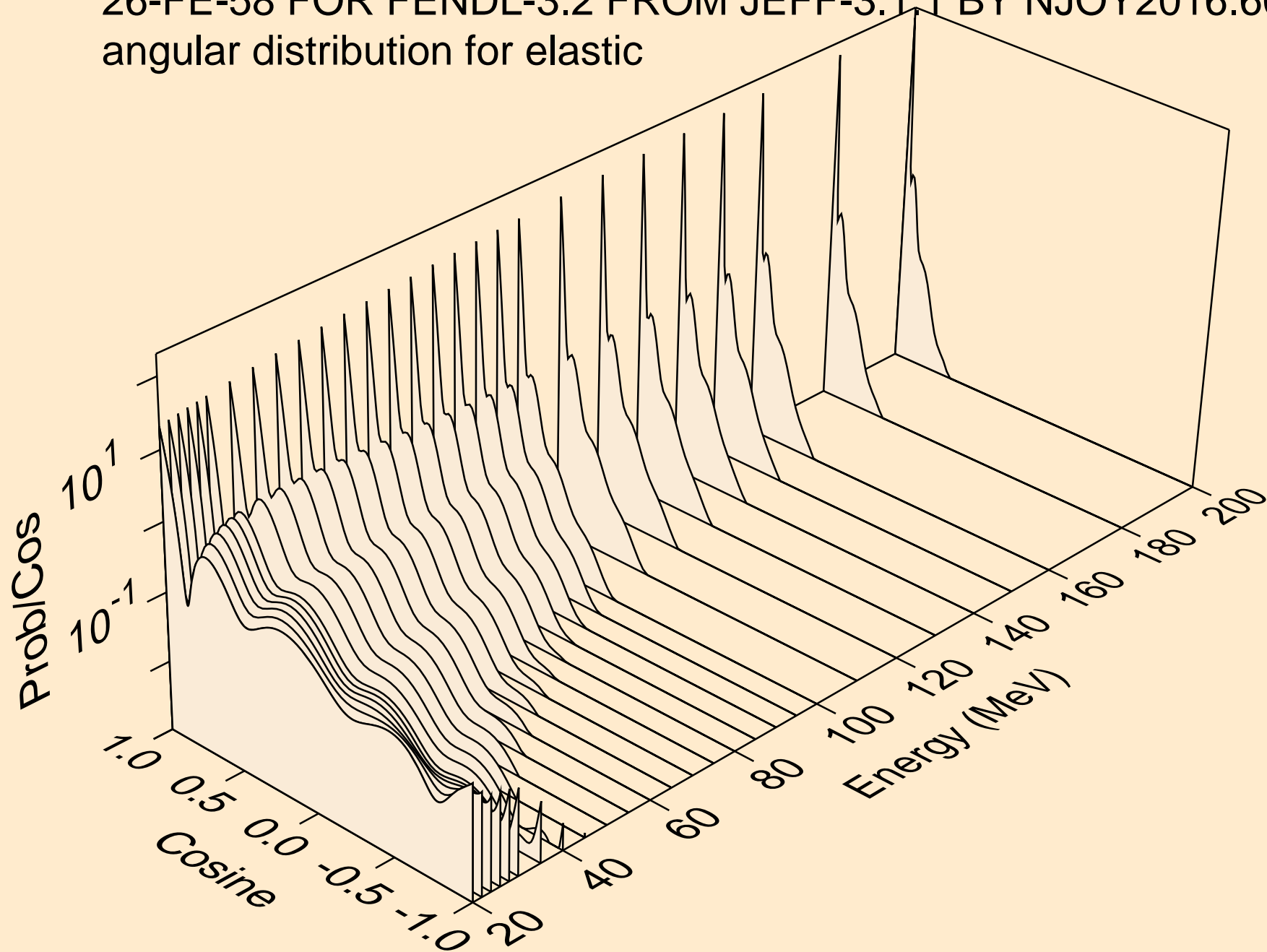

26-FE-58 FOR FENDL-3.2 FROM JEFF-3.1.1 BY NJOY2016.60+ ON
angular distribution for (n,n*1)

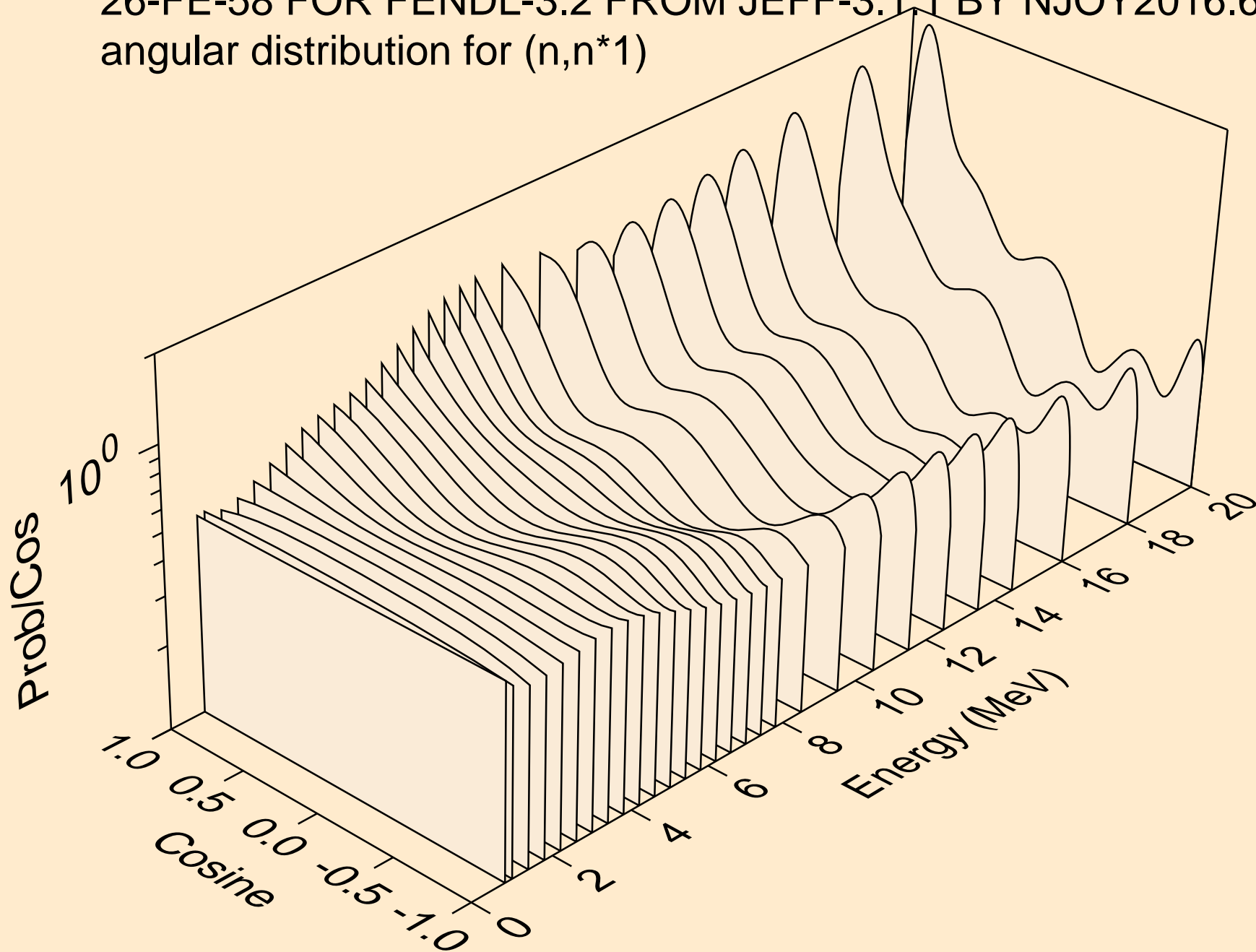

26-FE-58 FOR FENDL-3.2 FROM JEFF-3.1.1 BY NJOY2016.60+ ON
angular distribution for (n,n*2)

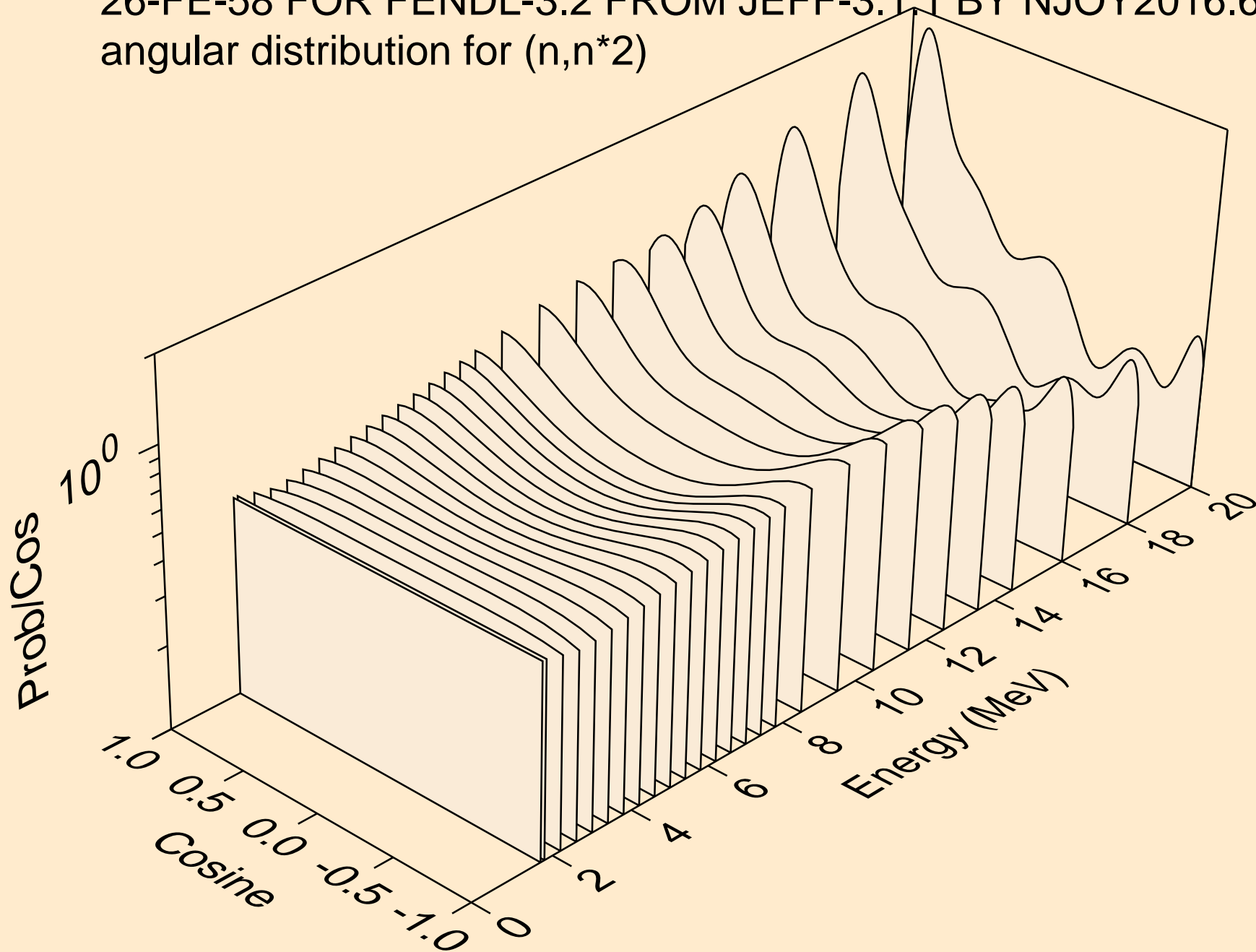

26-FE-58 FOR FENDL-3.2 FROM JEFF-3.1.1 BY NJOY2016.60+ ON
angular distribution for (n,n*3)

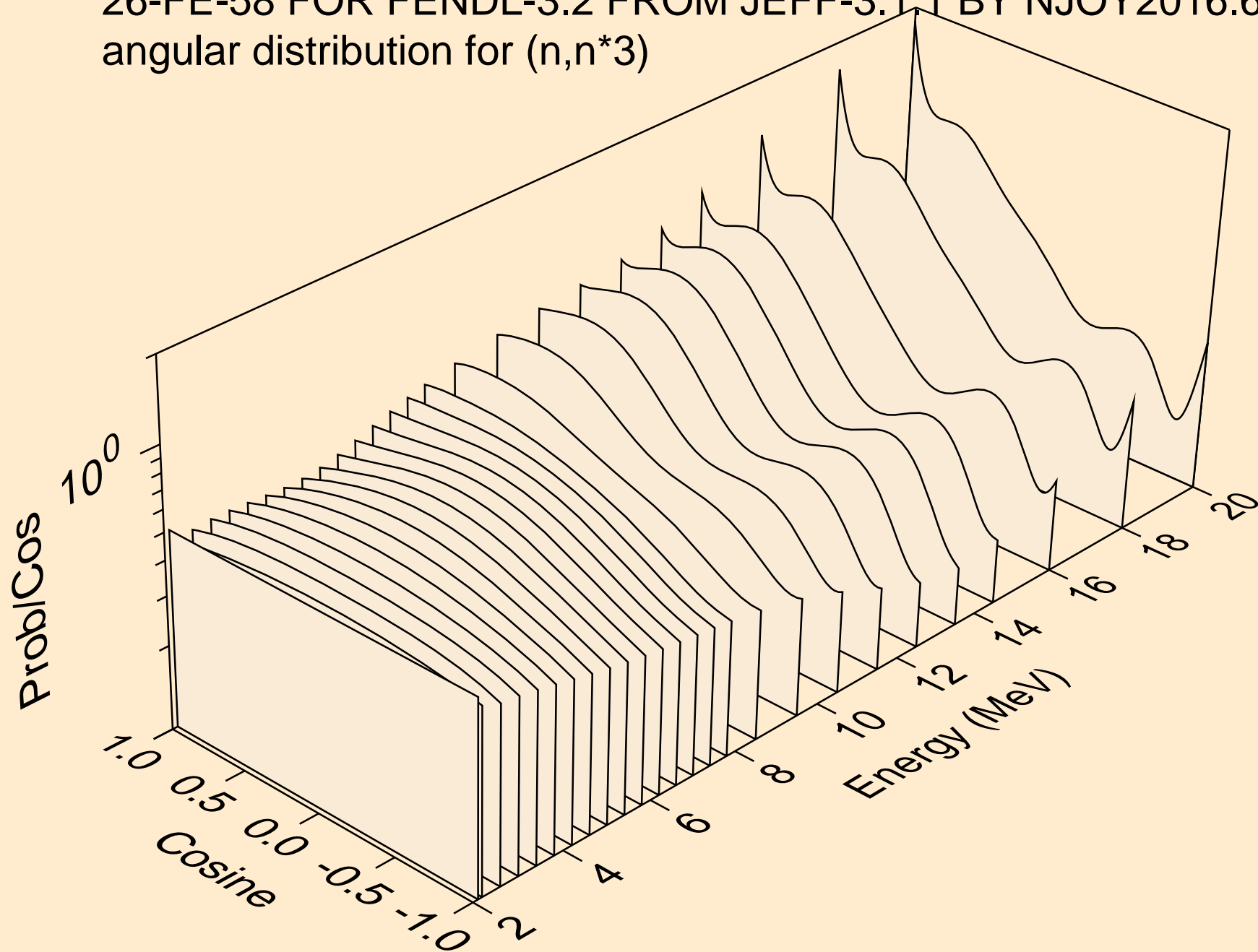

26-FE-58 FOR FENDL-3.2 FROM JEFF-3.1.1 BY NJOY2016.60+ ON
angular distribution for (n,n*4)

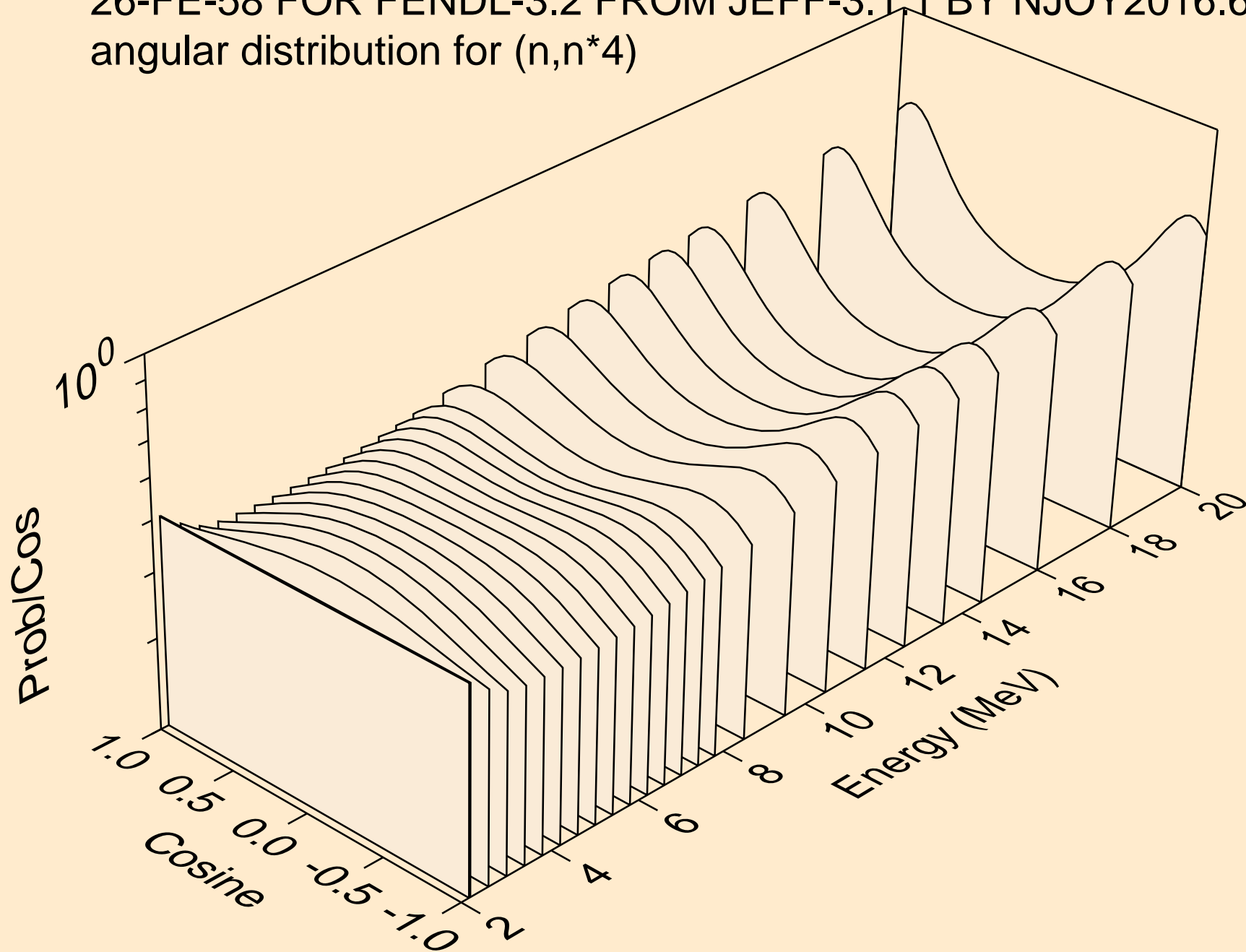

26-FE-58 FOR FENDL-3.2 FROM JEFF-3.1.1 BY NJOY2016.60+ ON
angular distribution for (n,n*5)

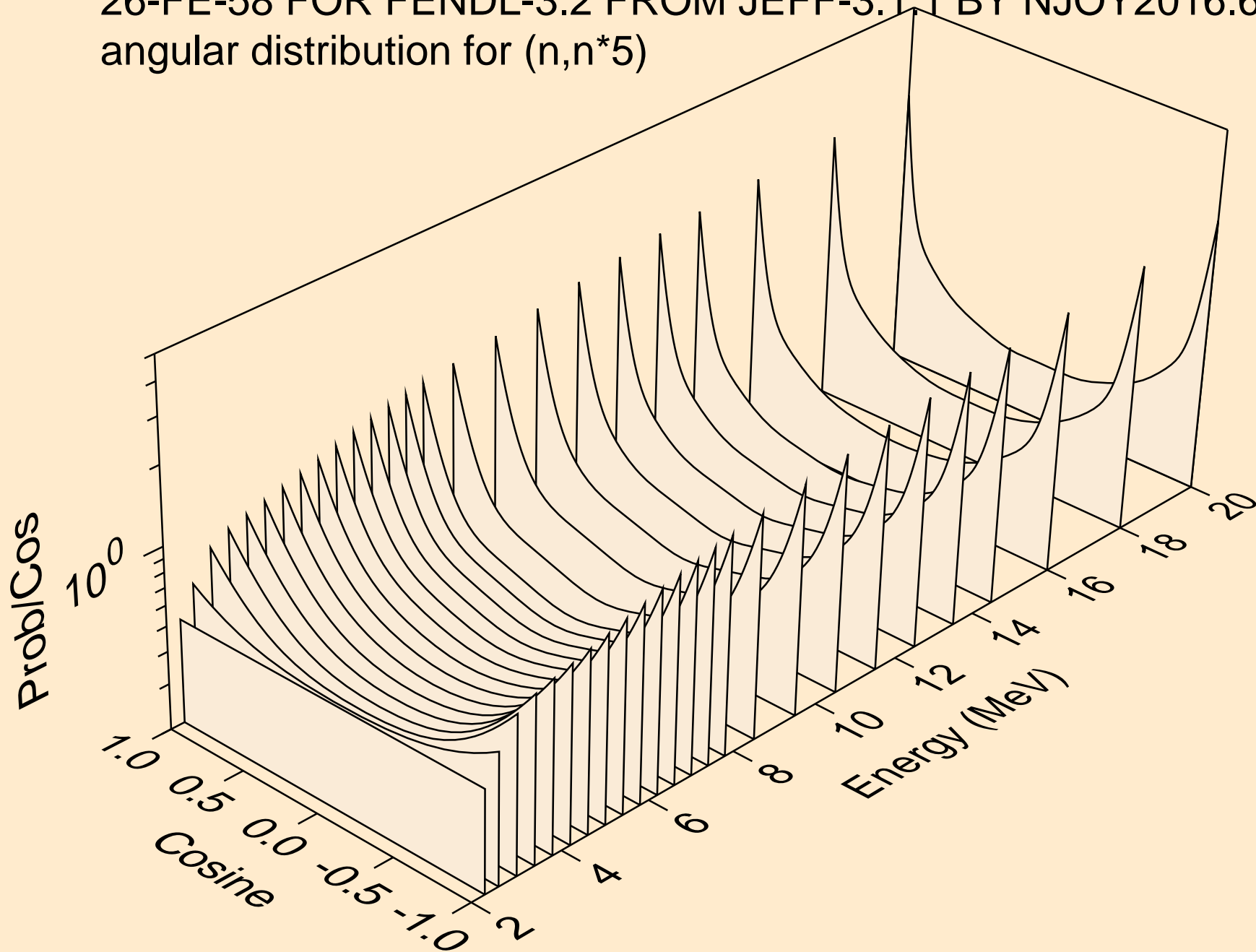

26-FE-58 FOR FENDL-3.2 FROM JEFF-3.1.1 BY NJOY2016.60+ ON
angular distribution for (n,n*6)

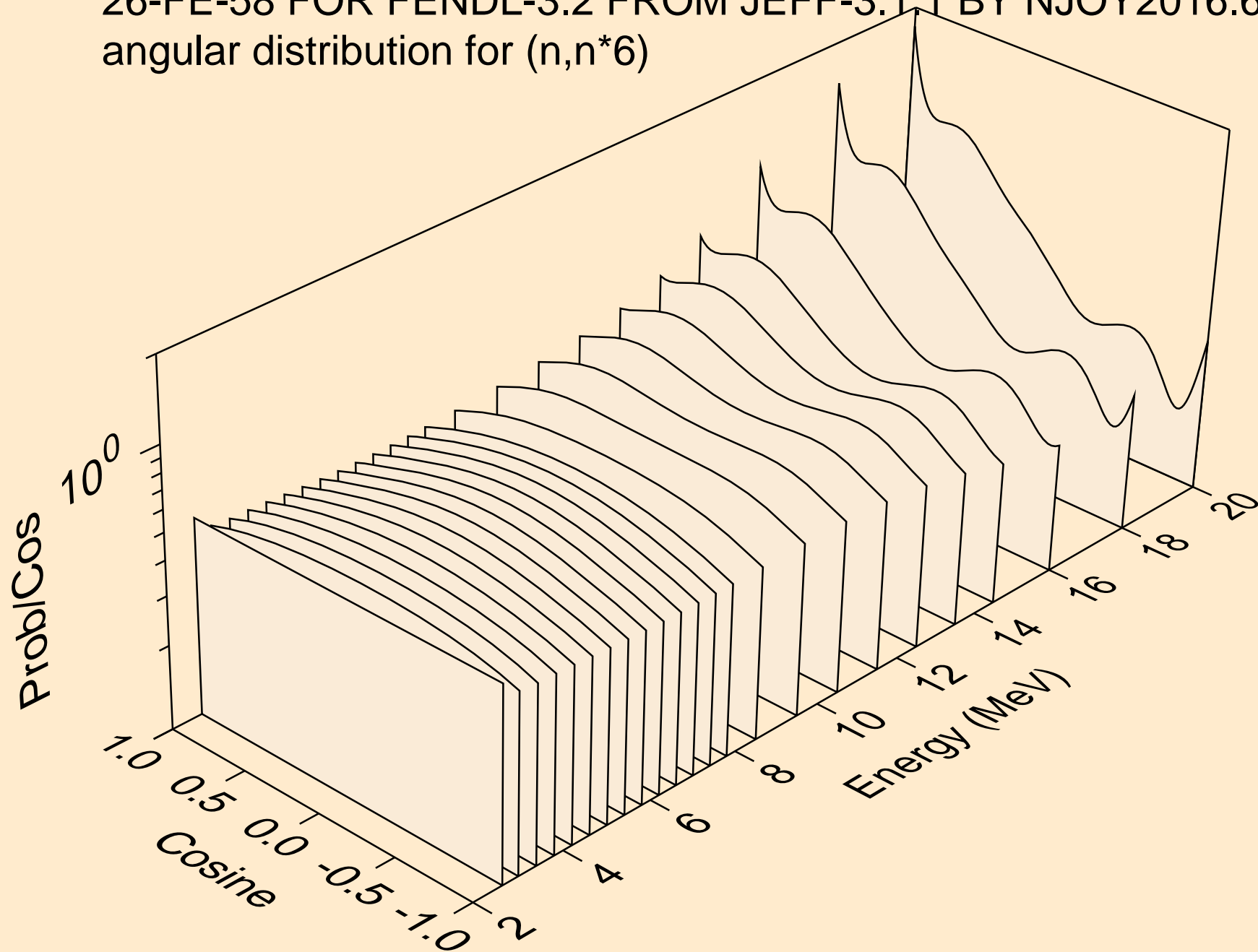

26-FE-58 FOR FENDL-3.2 FROM JEFF-3.1.1 BY NJOY2016.60+ ON
angular distribution for (n,n*7)

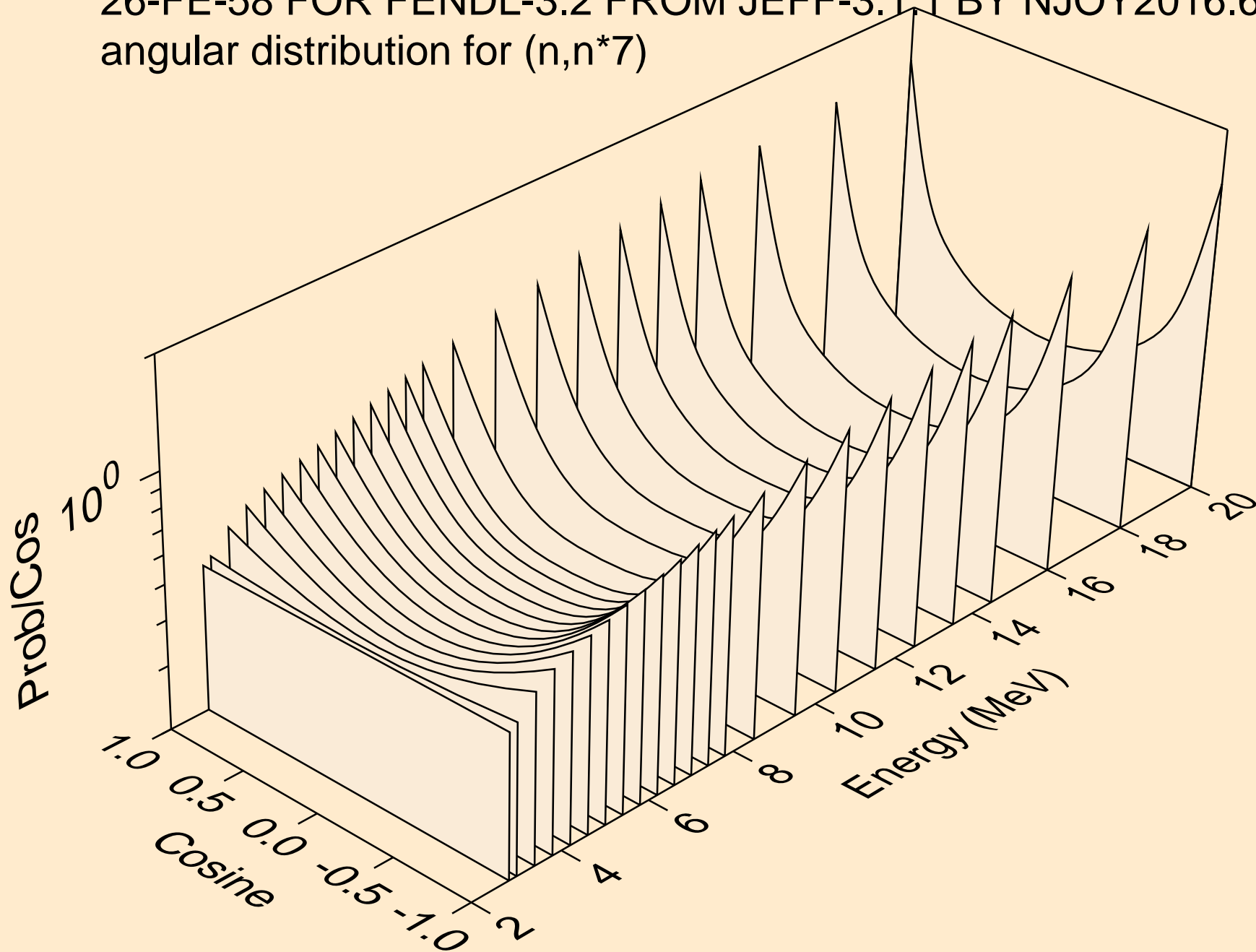

26-FE-58 FOR FENDL-3.2 FROM JEFF-3.1.1 BY NJOY2016.60+ ON
angular distribution for (n,n*8)

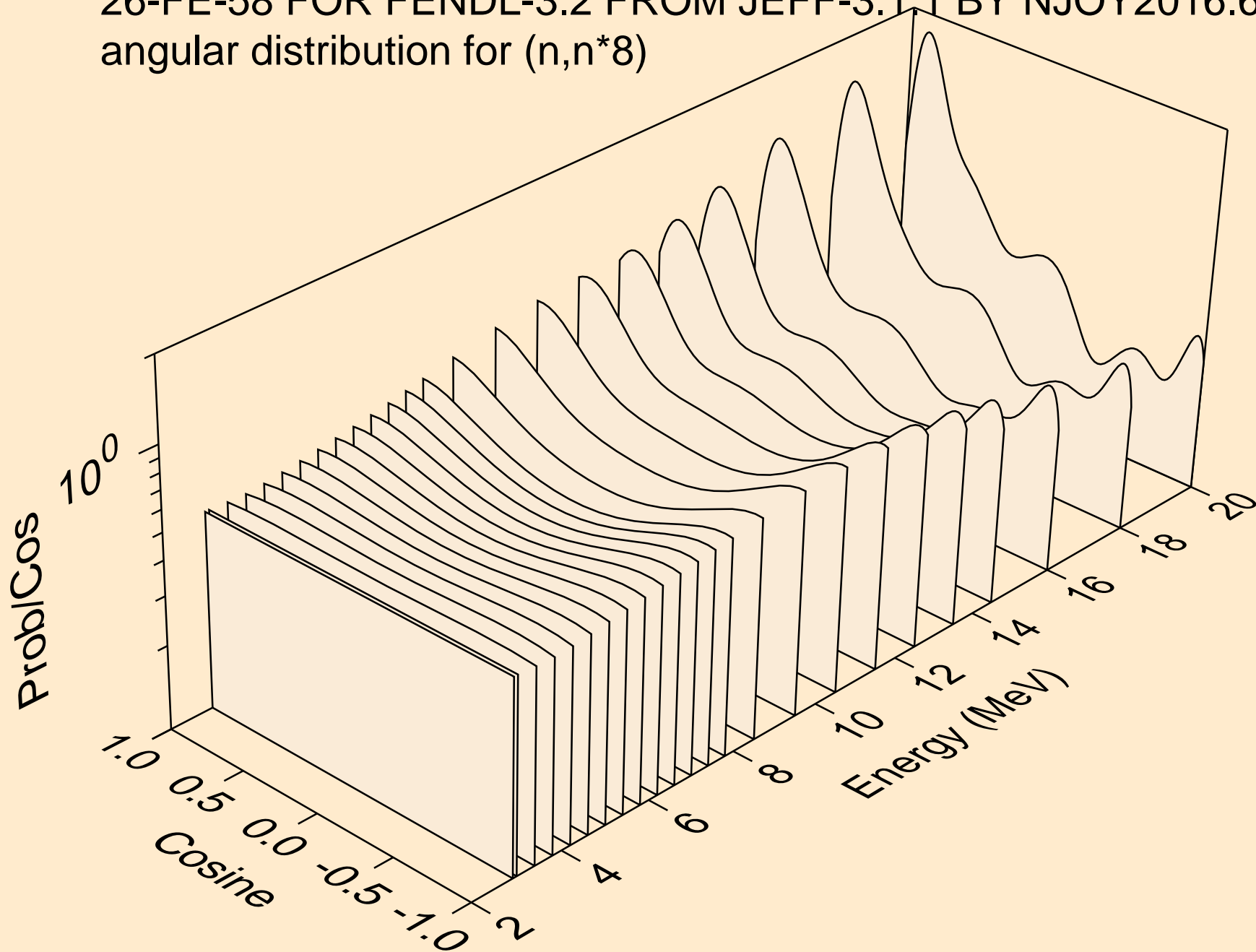

26-FE-58 FOR FENDL-3.2 FROM JEFF-3.1.1 BY NJOY2016.60+ ON
angular distribution for (n,n*9)

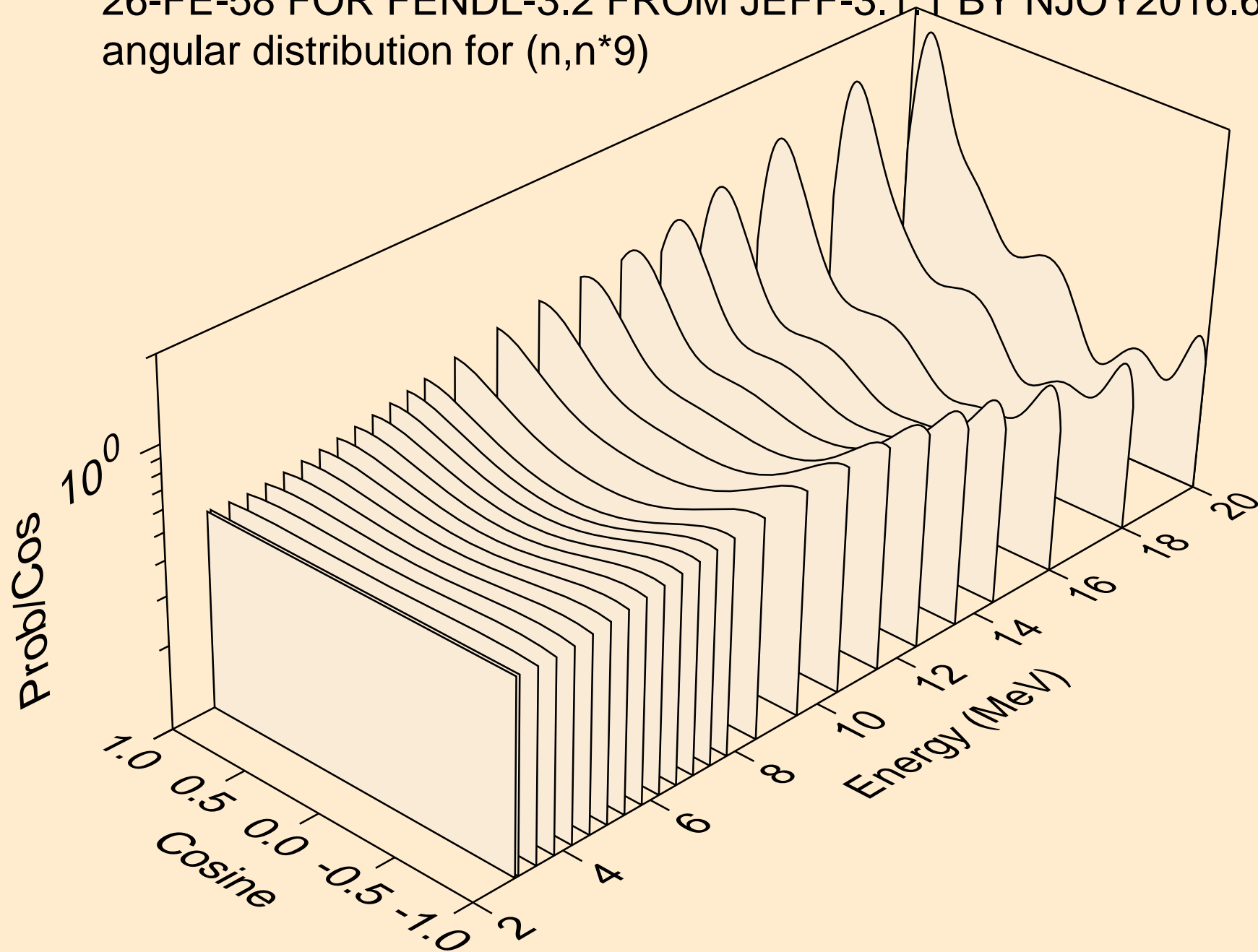

26-FE-58 FOR FENDL-3.2 FROM JEFF-3.1.1 BY NJOY2016.60+ ON
angular distribution for (n,n*10)

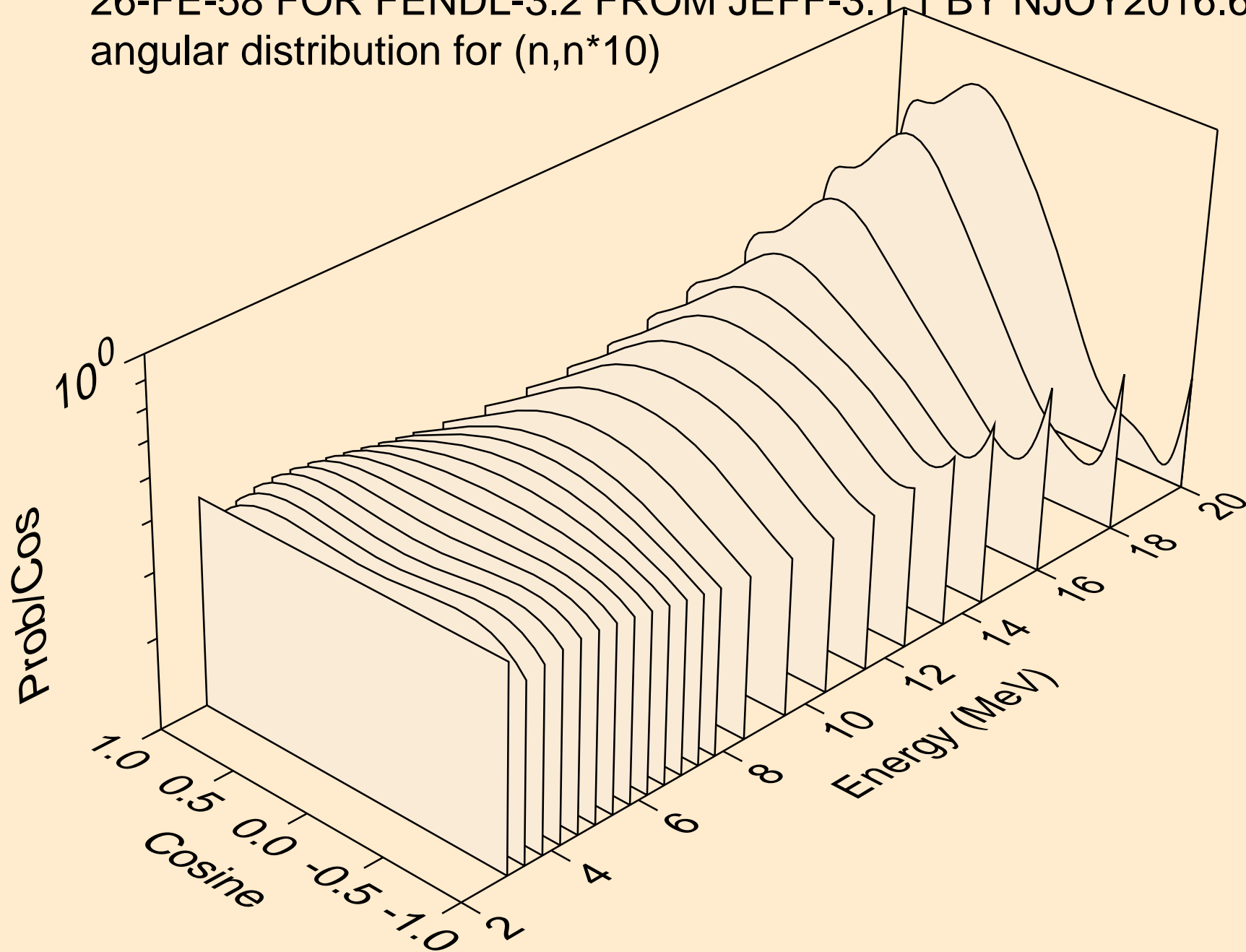

26-FE-58 FOR FENDL-3.2 FROM JEFF-3.1.1 BY NJOY2016.60+ ON
angular distribution for (n,n*11)

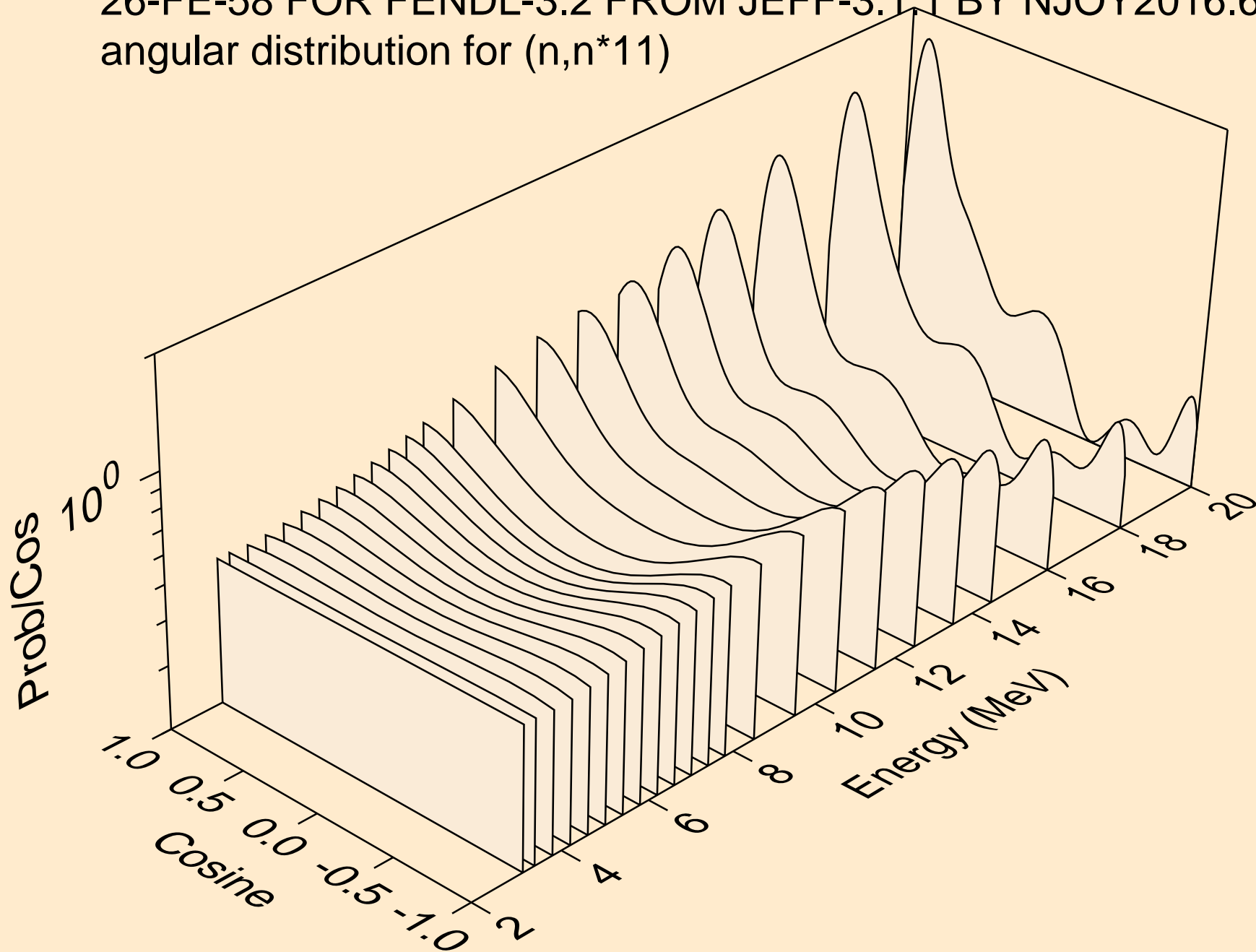

26-FE-58 FOR FENDL-3.2 FROM JEFF-3.1.1 BY NJOY2016.60+ ON
angular distribution for (n,n*12)

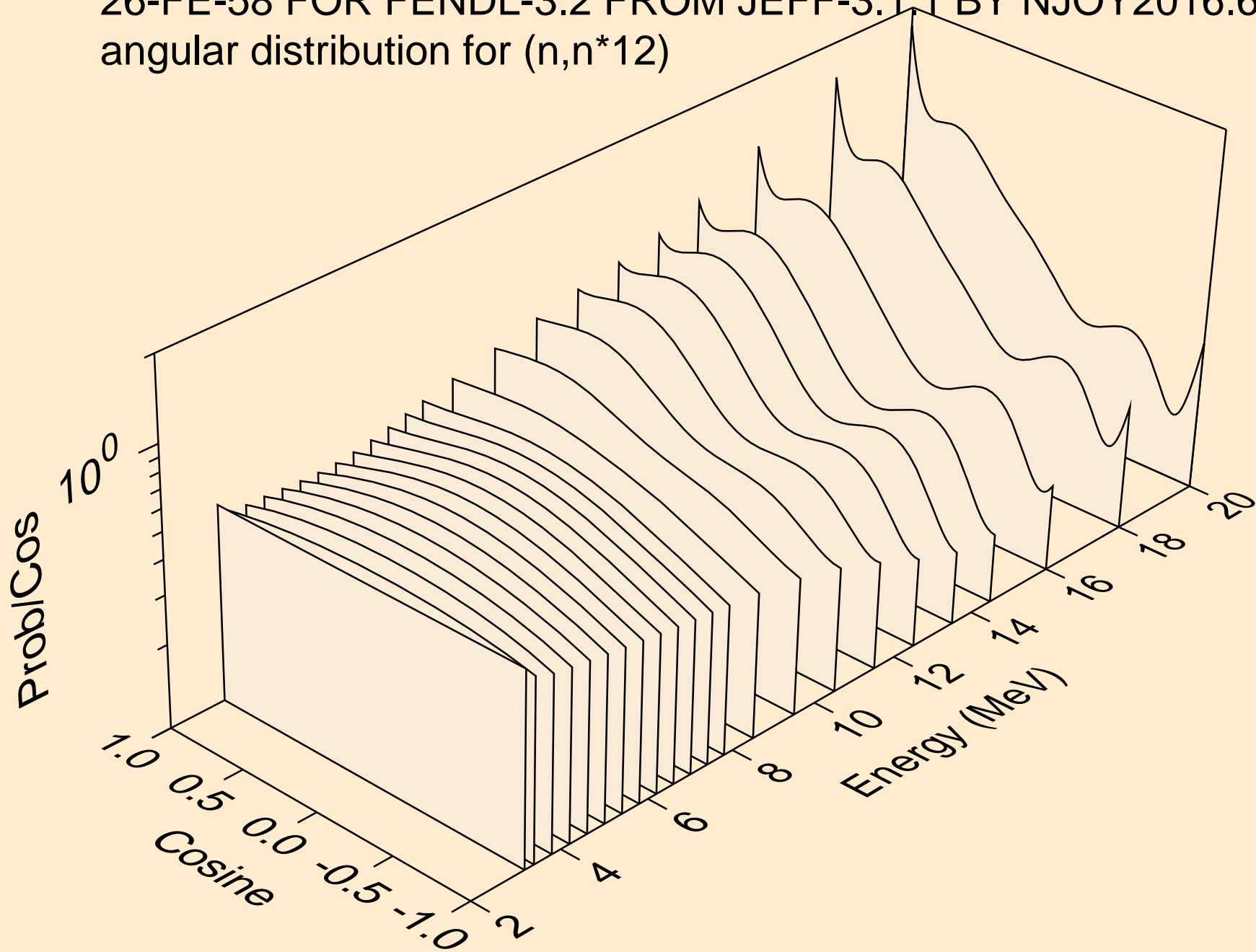

26-FE-58 FOR FENDL-3.2 FROM JEFF-3.1.1 BY NJOY2016.60+ ON
angular distribution for (n,n*13)

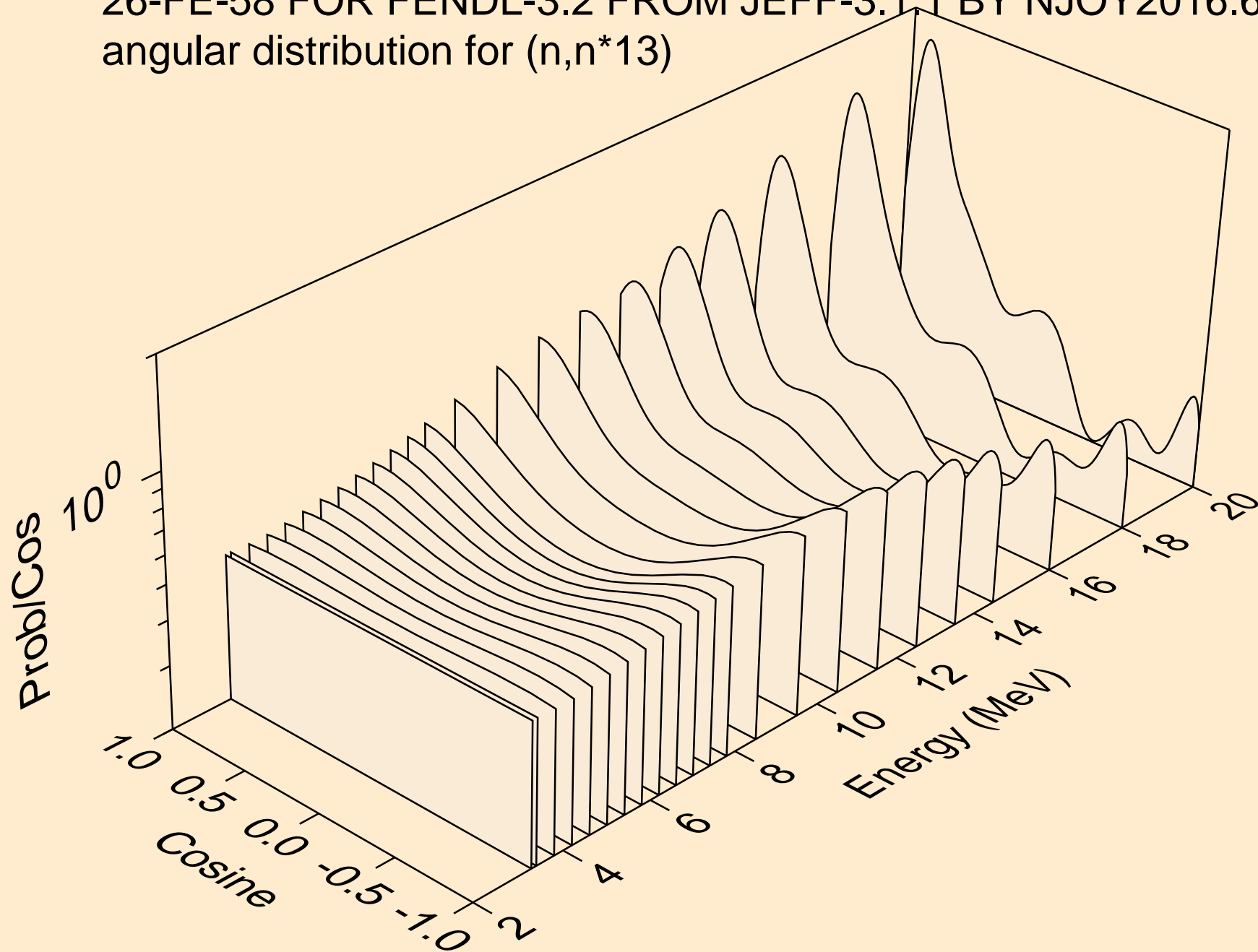

26-FE-58 FOR FENDL-3.2 FROM JEFF-3.1.1 BY NJOY2016.60+ ON
angular distribution for (n,n*14)

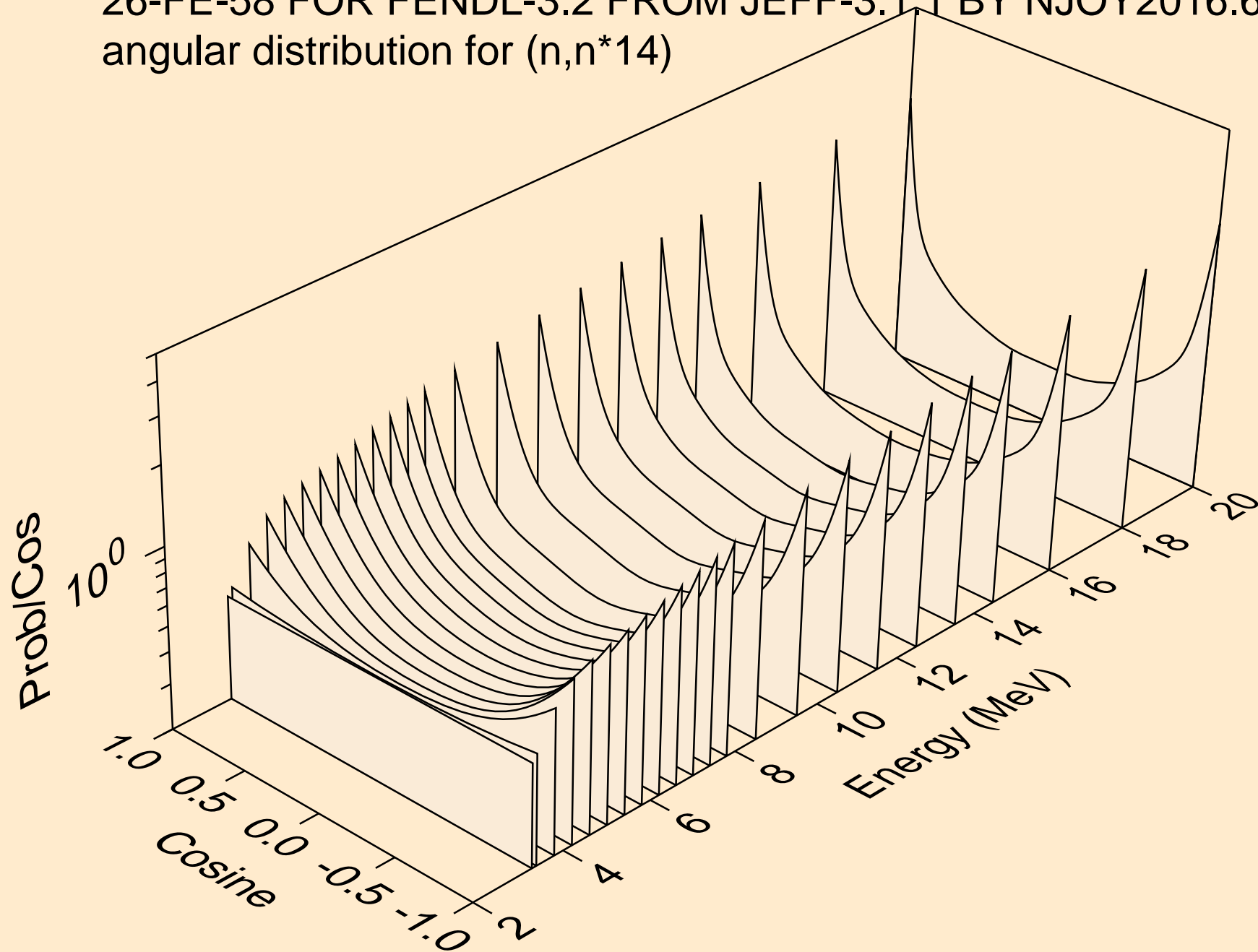

26-FE-58 FOR FENDL-3.2 FROM JEFF-3.1.1 BY NJOY2016.60+ ON
angular distribution for (n,n*15)

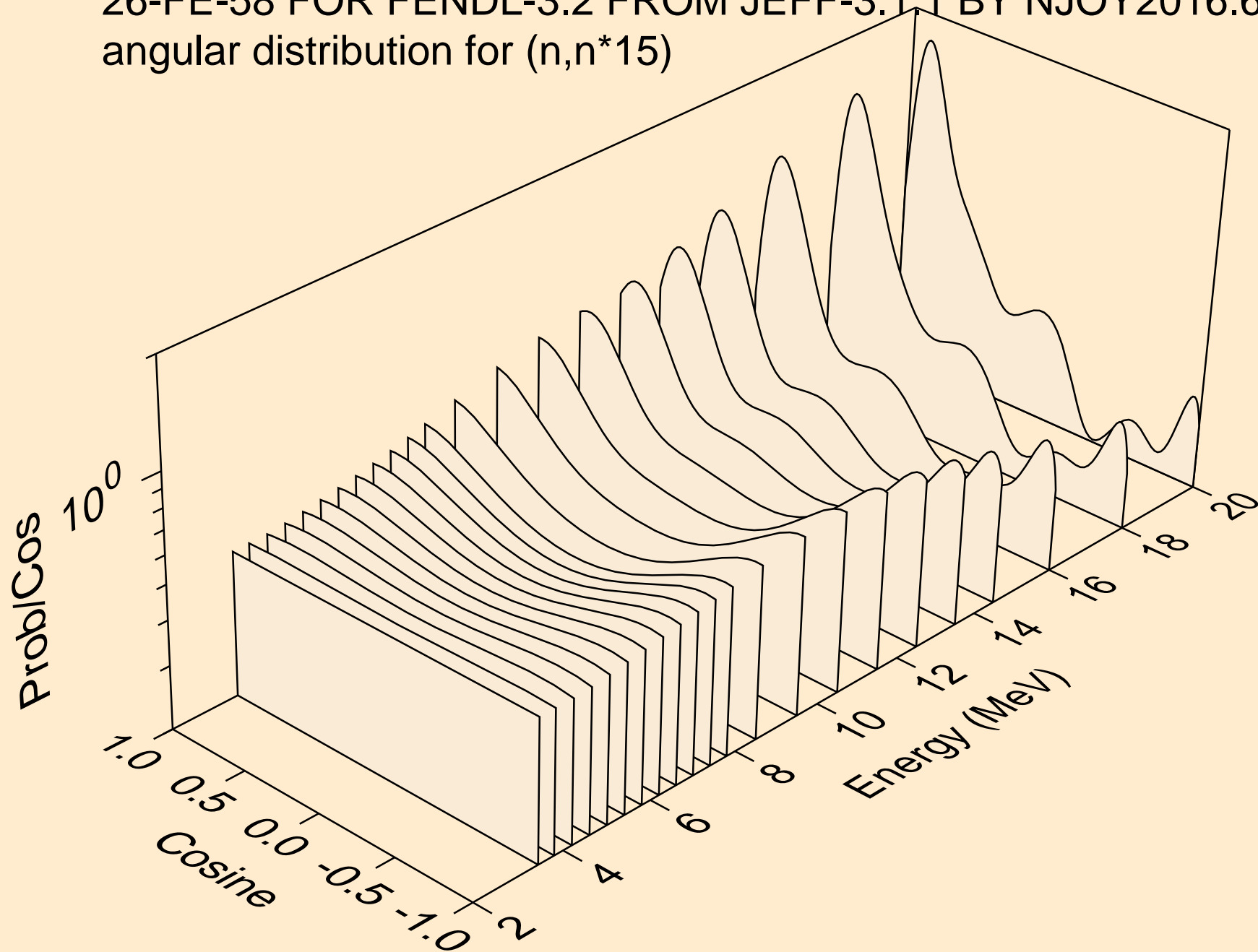

26-FE-58 FOR FENDL-3.2 FROM JEFF-3.1.1 BY NJOY2016.60+ ON
angular distribution for (n,n*16)

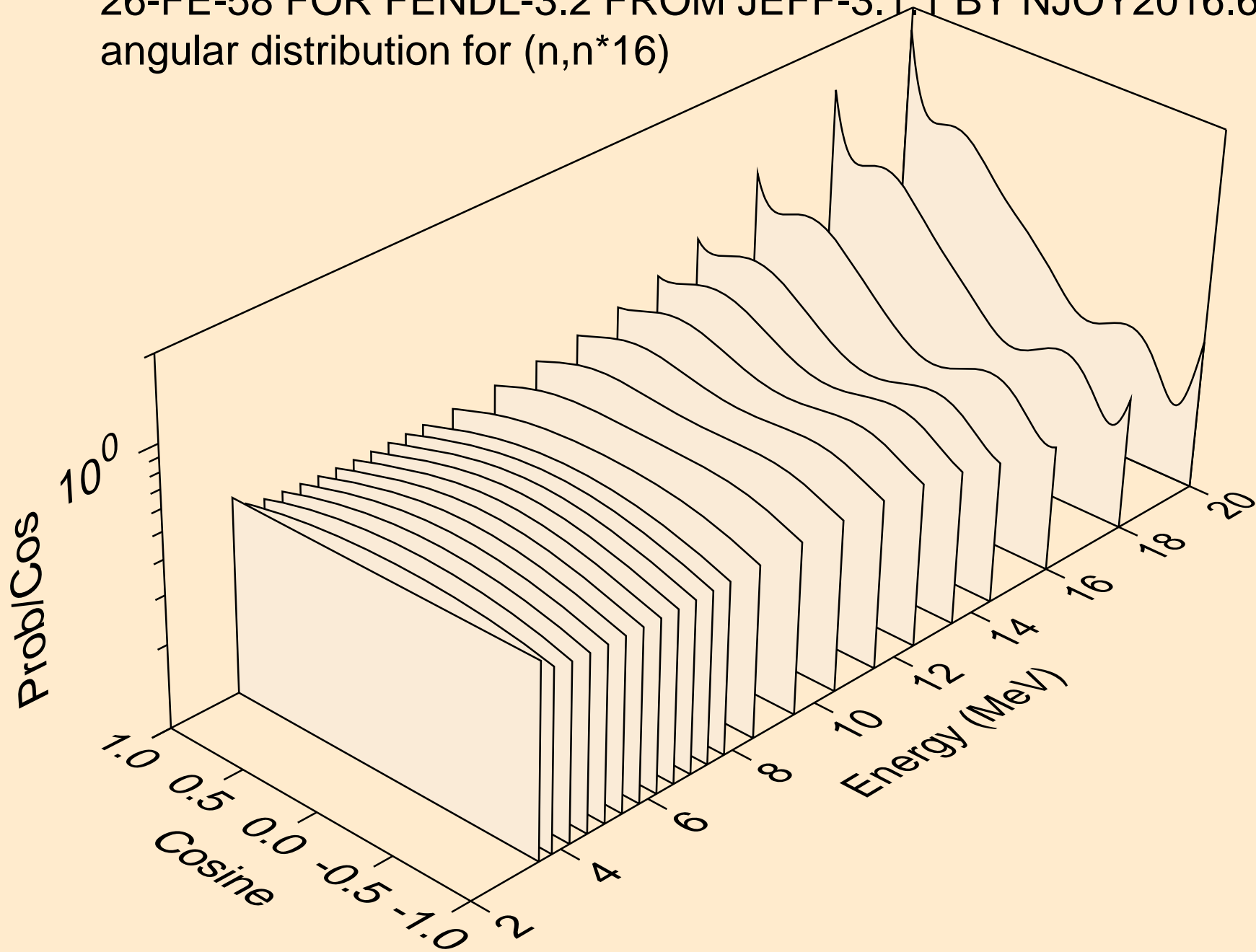

26-FE-58 FOR FENDL-3.2 FROM JEFF-3.1.1 BY NJOY2016.60+ ON
angular distribution for (n,n*17)

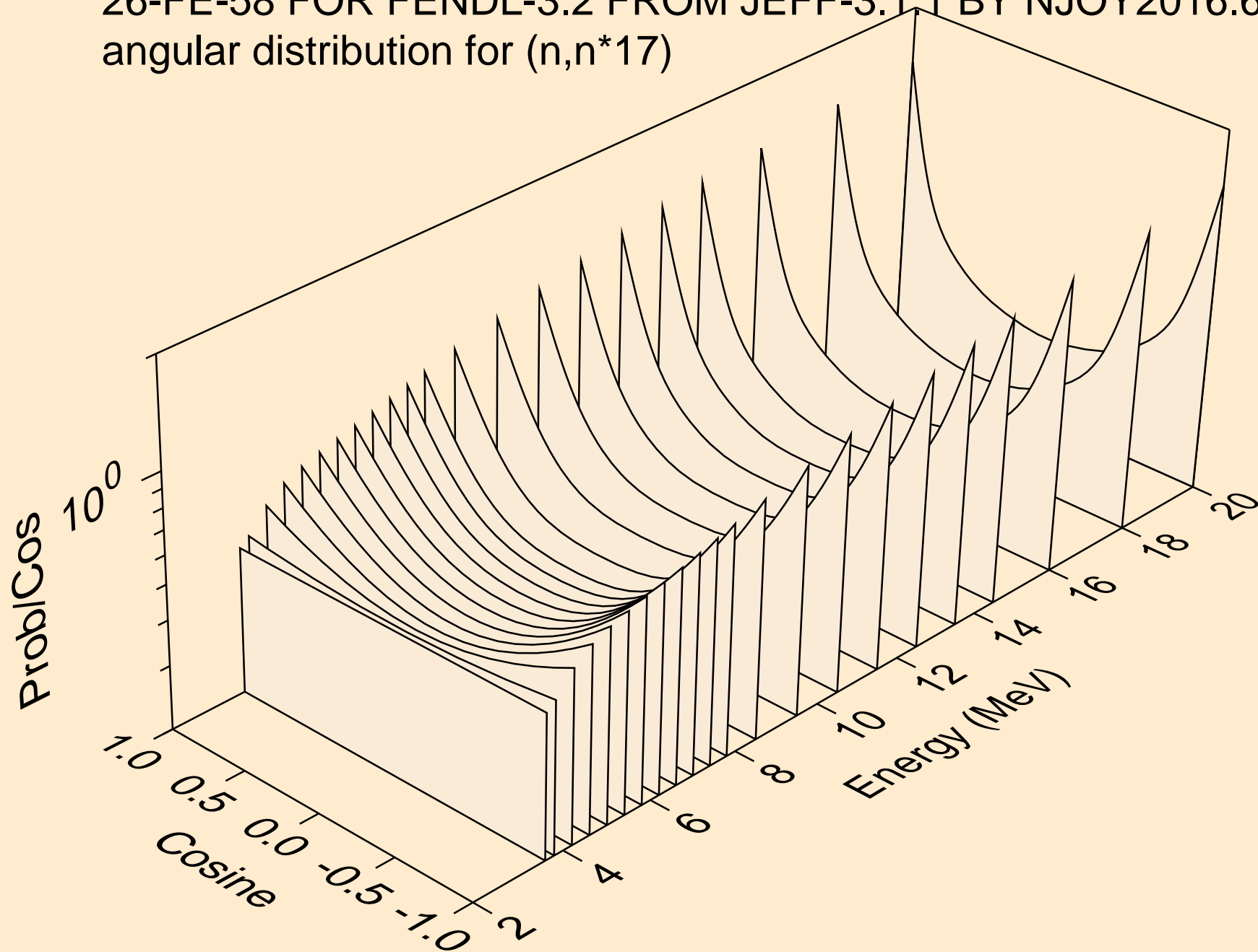

26-FE-58 FOR FENDL-3.2 FROM JEFF-3.1.1 BY NJOY2016.60+ ON
angular distribution for (n,n*18)

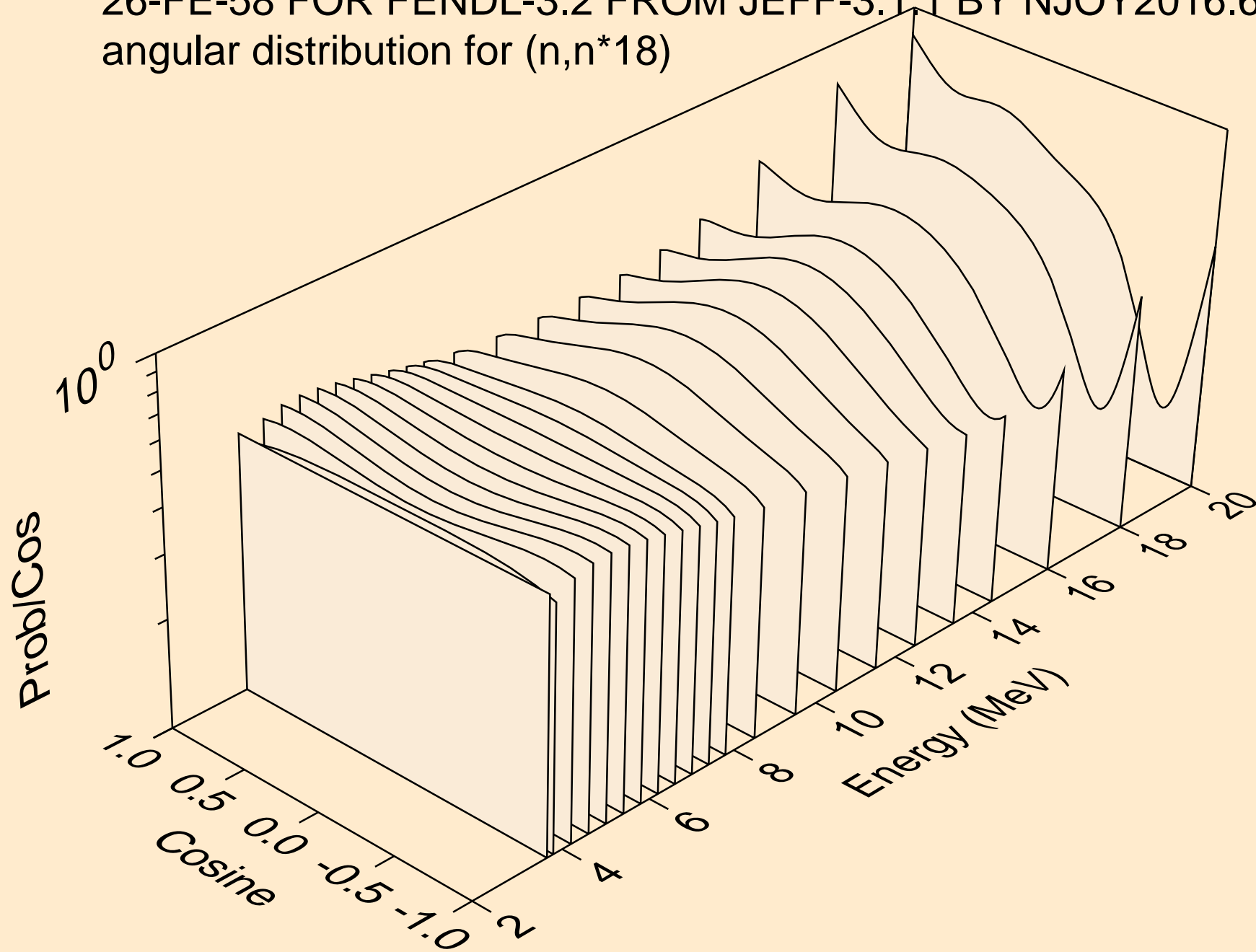

26-FE-58 FOR FENDL-3.2 FROM JEFF-3.1.1 BY NJOY2016.60+ ON
angular distribution for (n,n*19)

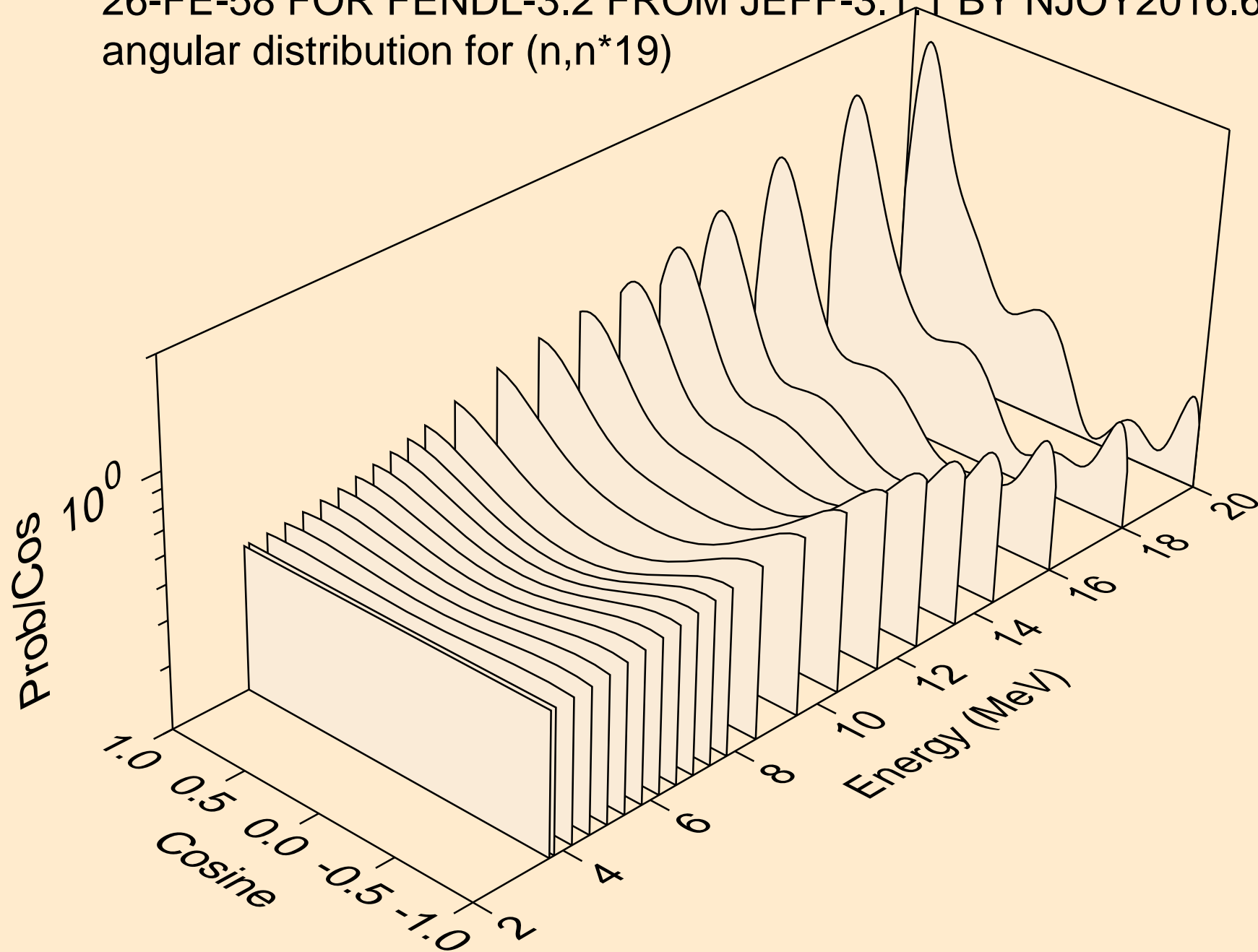

26-FE-58 FOR FENDL-3.2 FROM JEFF-3.1.1 BY NJOY2016.60+ ON
angular distribution for (n,n*20)

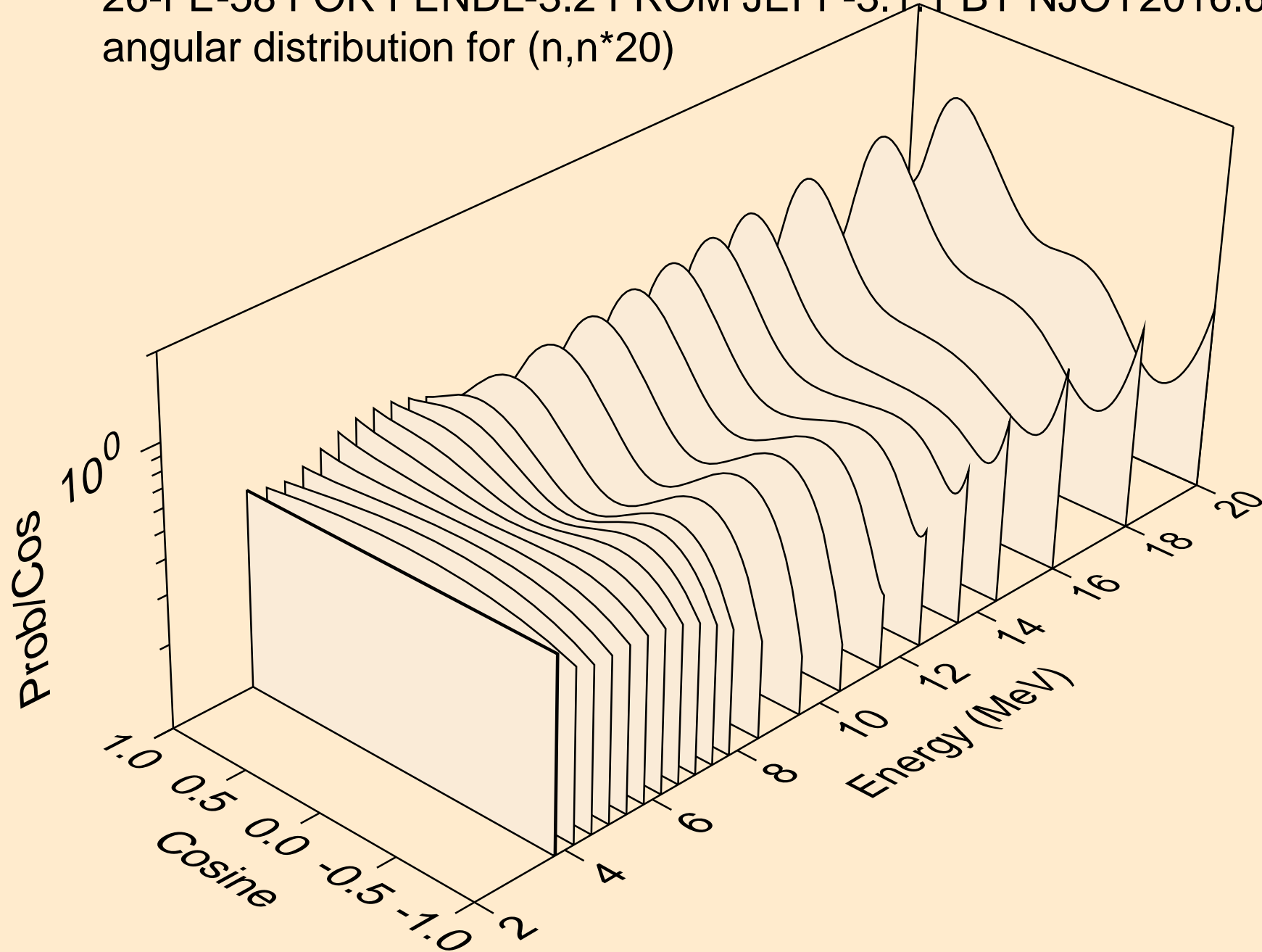

26-FE-58 FOR FENDL-3.2 FROM JEFF-3.1.1 BY NJOY2016.60+ ON
Neutron emission for (n,x)

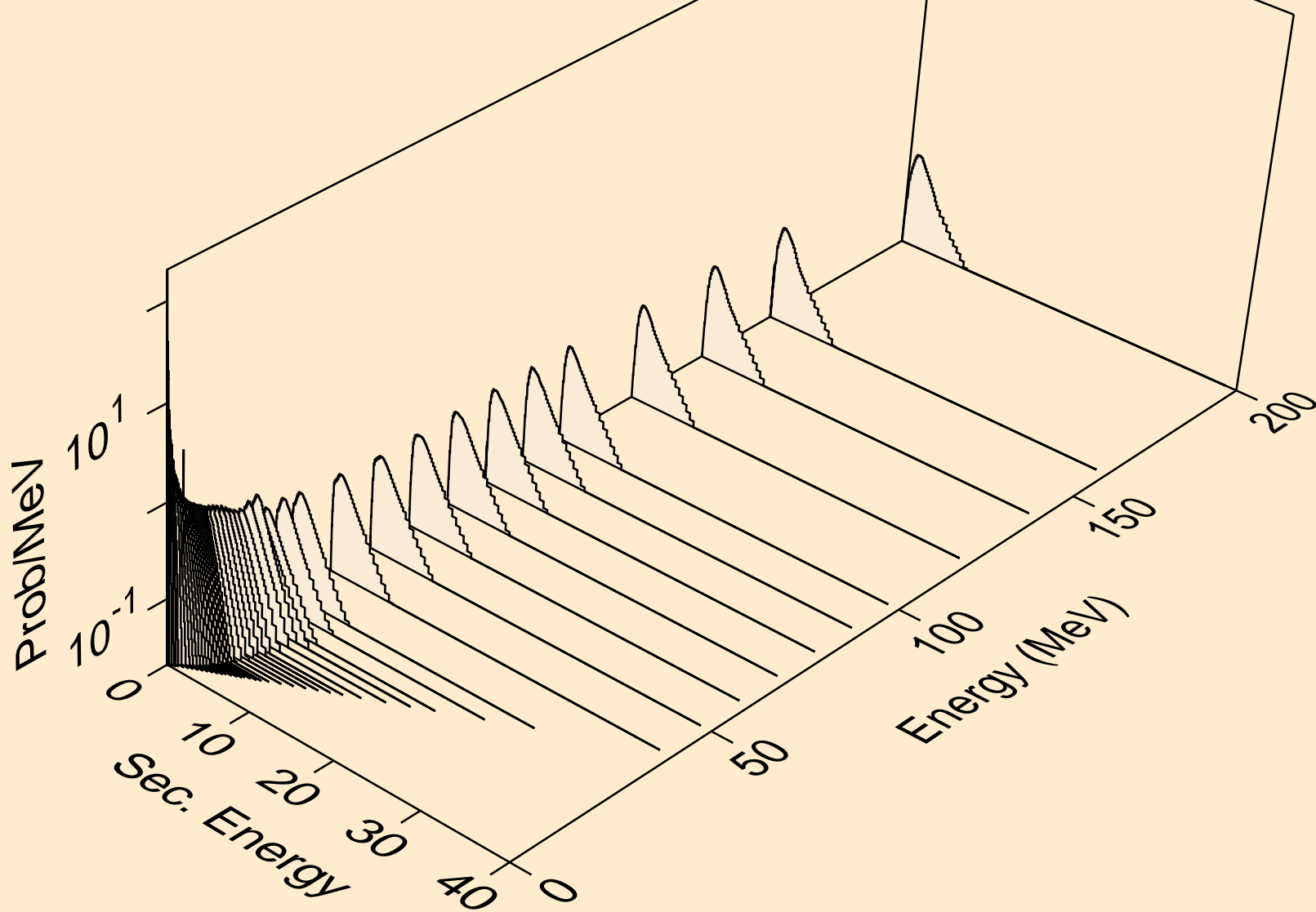

26-FE-58 FOR FENDL-3.2 FROM JEFF-3.1.1 BY NJOY2016.60+ ON
Neutron emission for (n,2n)

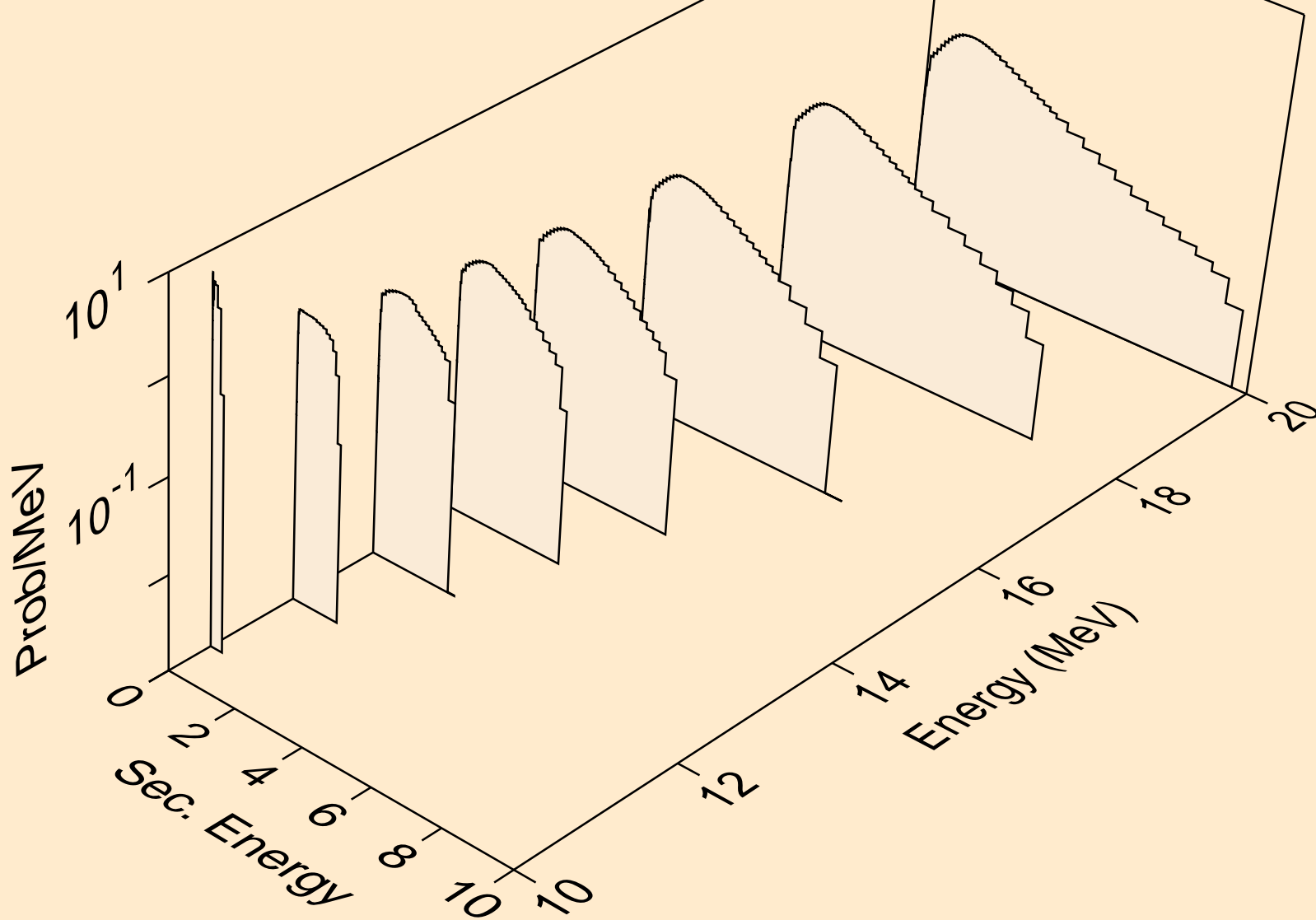

26-FE-58 FOR FENDL-3.2 FROM JEFF-3.1.1 BY NJOY2016.60+ ON
Neutron emission for (n,3n)

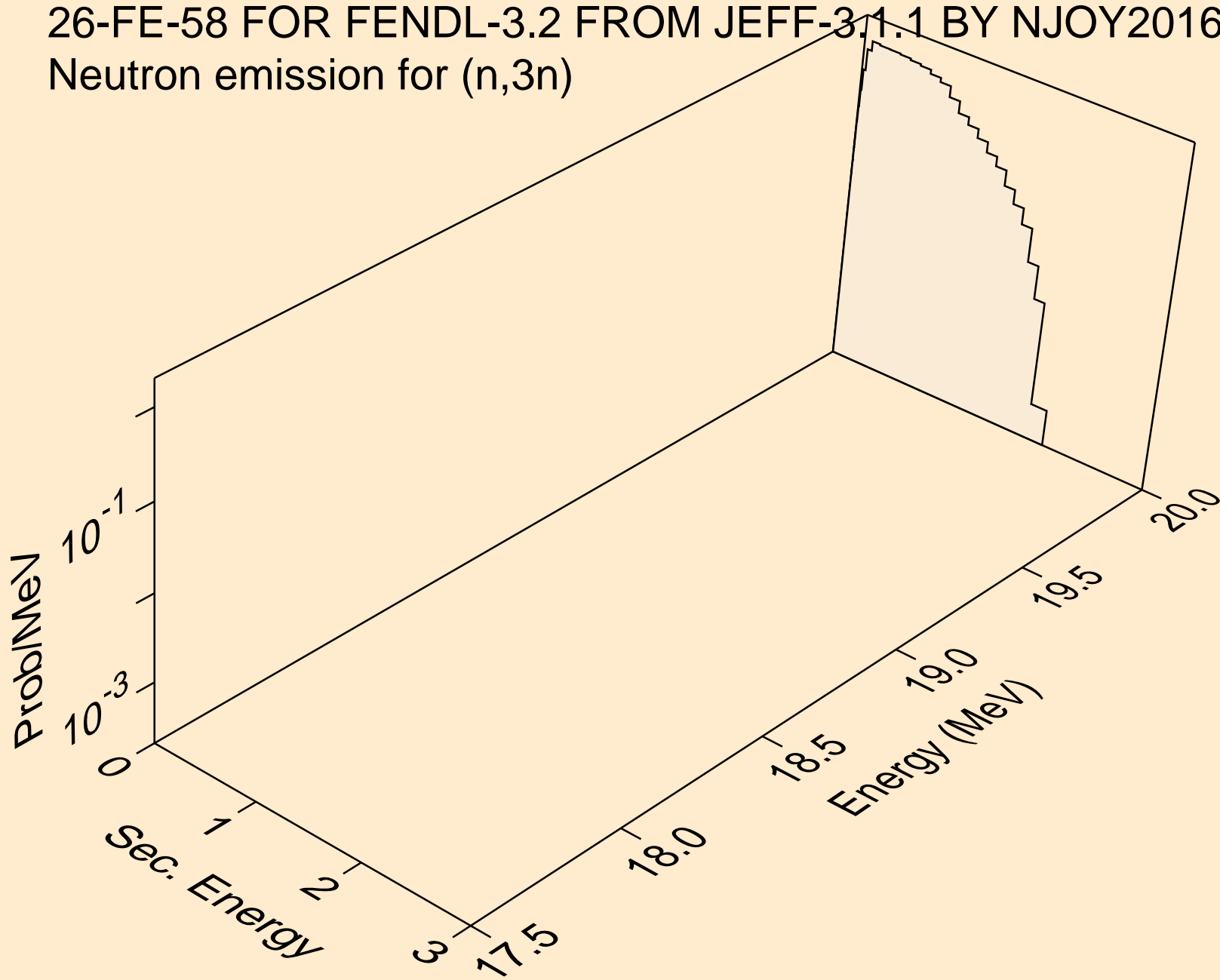

26-FE-58 FOR FENDL-3.2 FROM JEFF-3.1.1 BY NJOY2016.60+ ON
Neutron emission for (n,n*)a

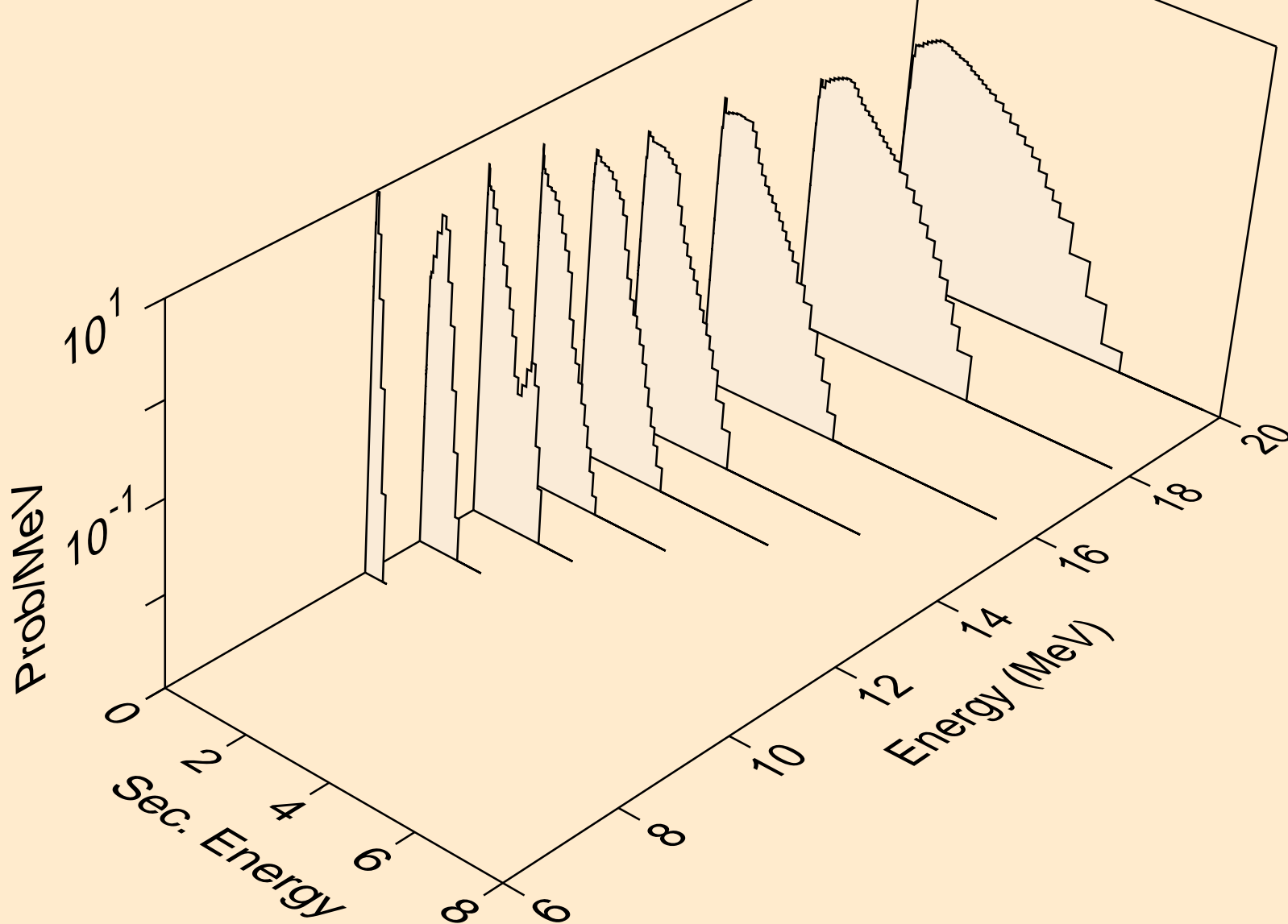

26-FE-58 FOR FENDL-3.2 FROM JEFF-3.1.1 BY NJOY2016.60+ ON
Neutron emission for (n,n*)p

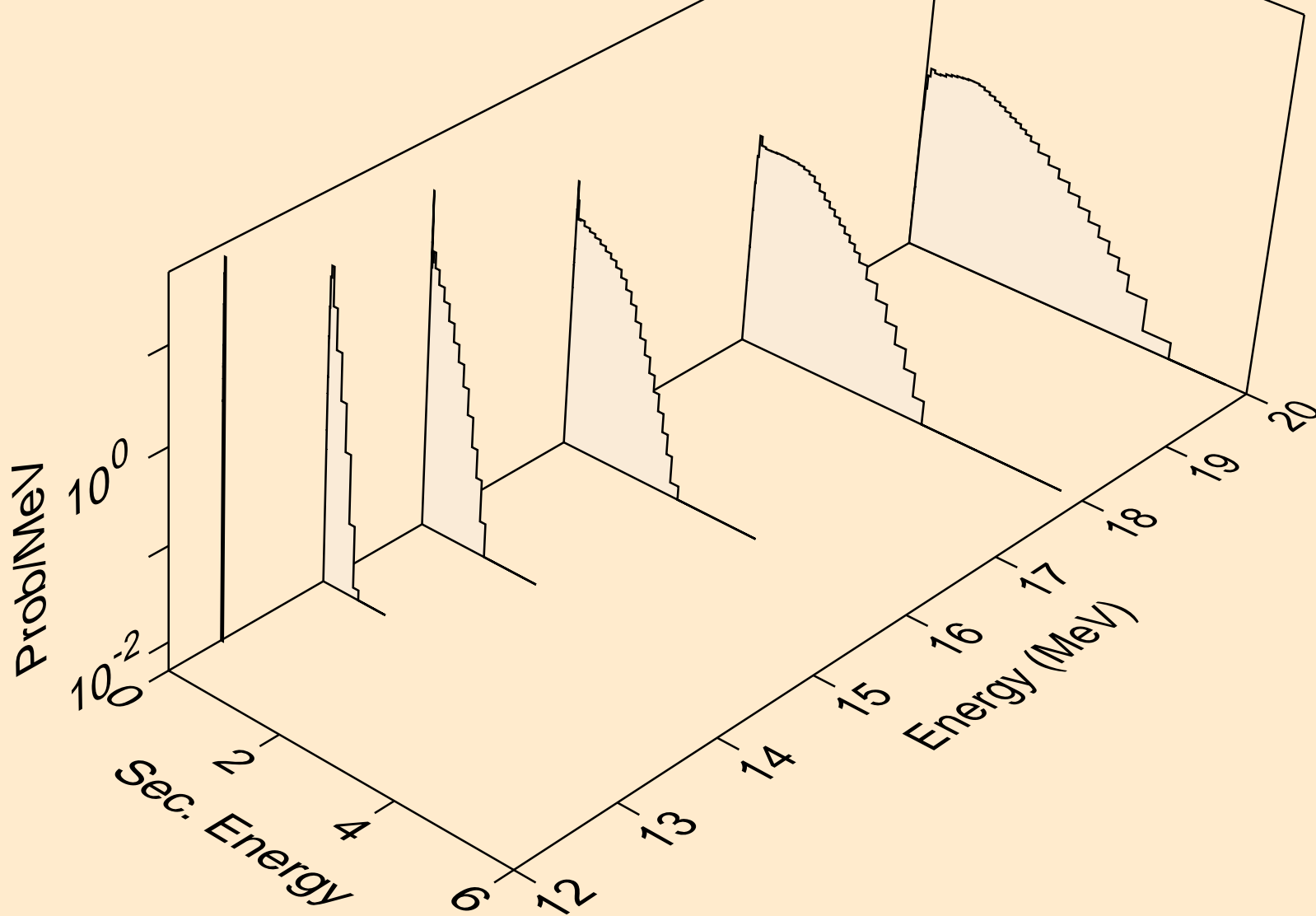

26-FE-58 FOR FENDL-3.2 FROM JEFF-3.1.1 BY NJOY2016.60+ ON
Neutron emission for (n,n*c)

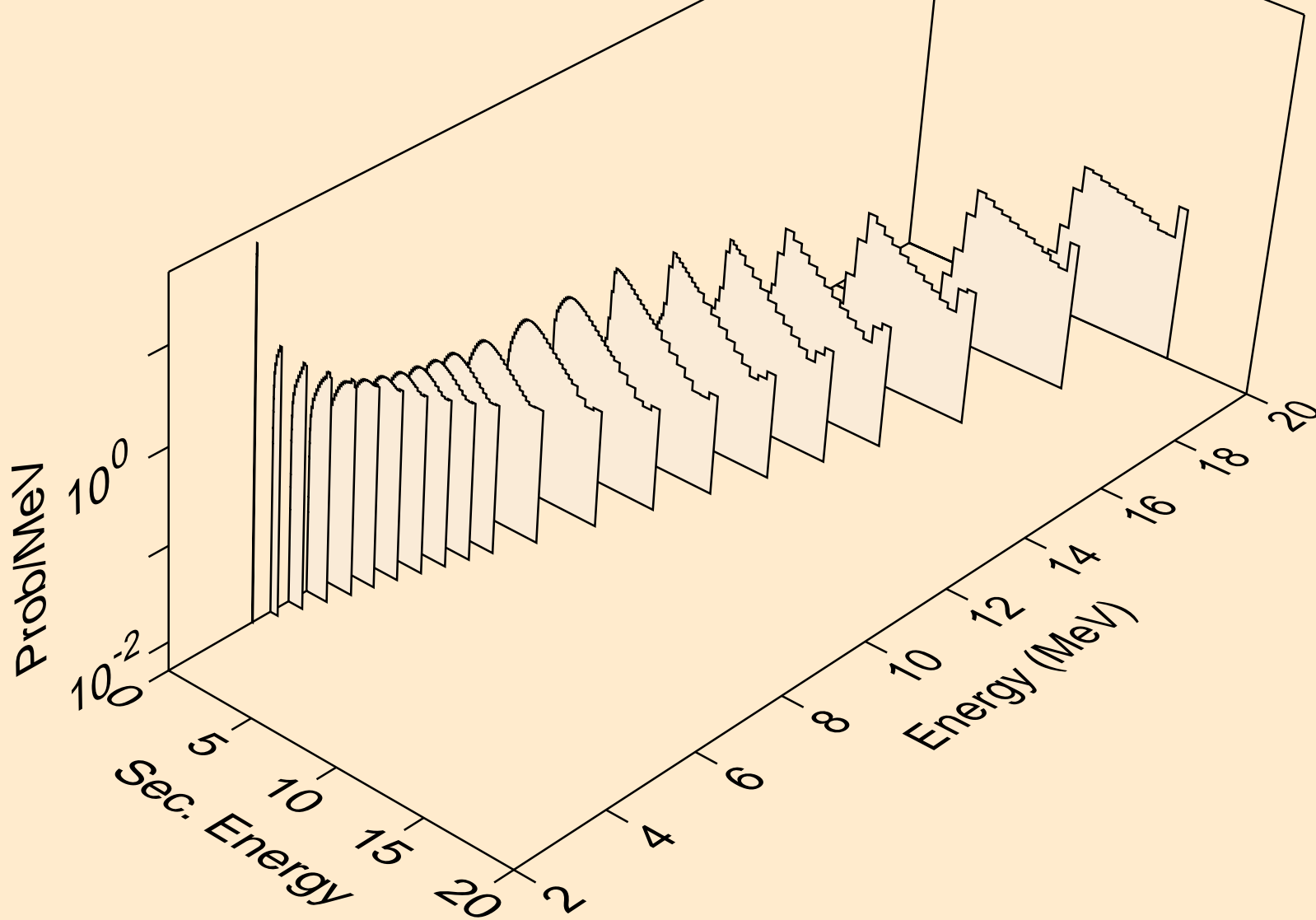

26-FE-58 FOR FENDL-3.2 FROM JEFF-3.1.1 BY NJOY2016.60+ ON
Photon emission for (n,x)

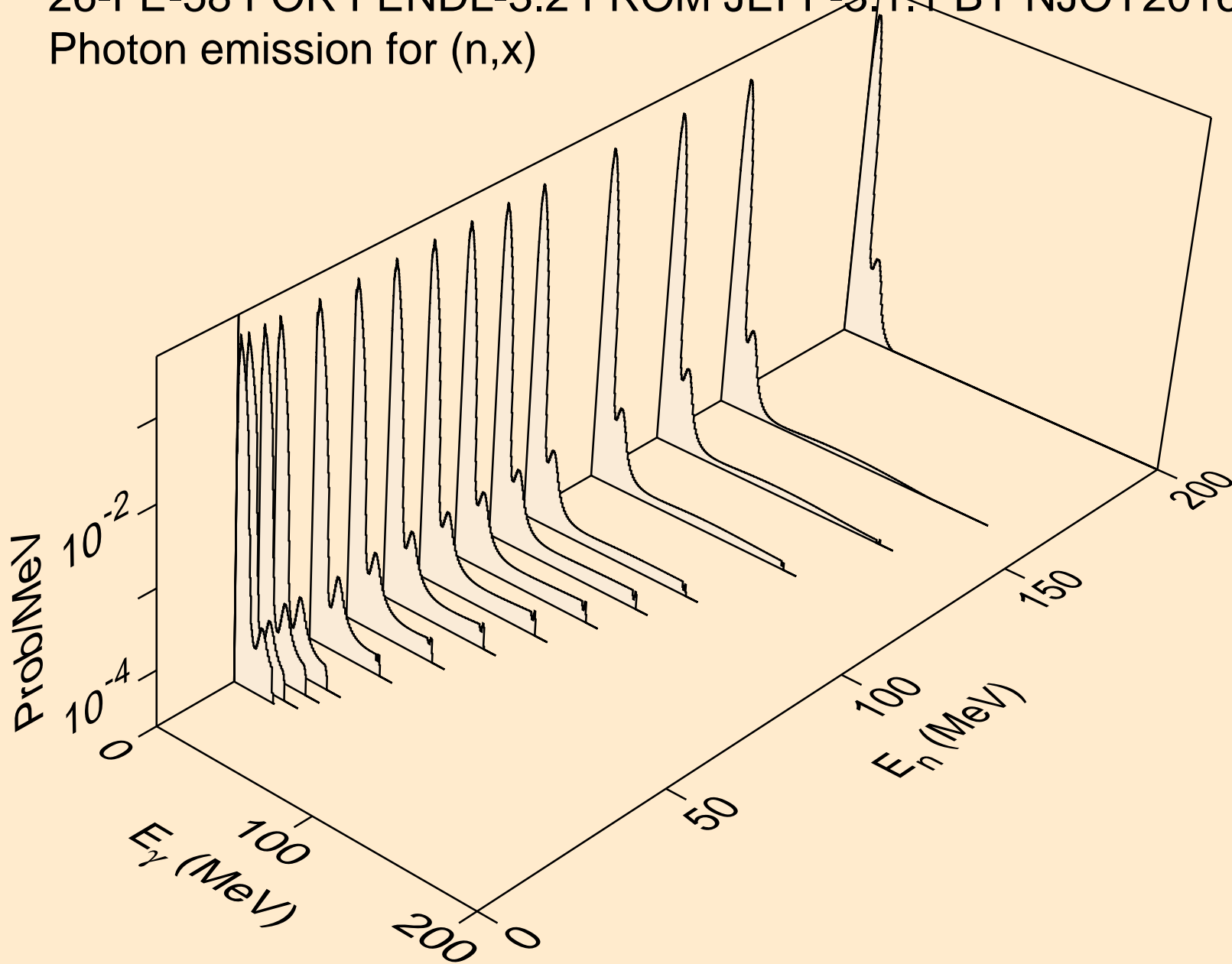

26-FE-58 FOR FENDL-3.2 FROM JEFF-3.1.1 BY NJOY2016.60+ ON
Photon emission for (n,2n)

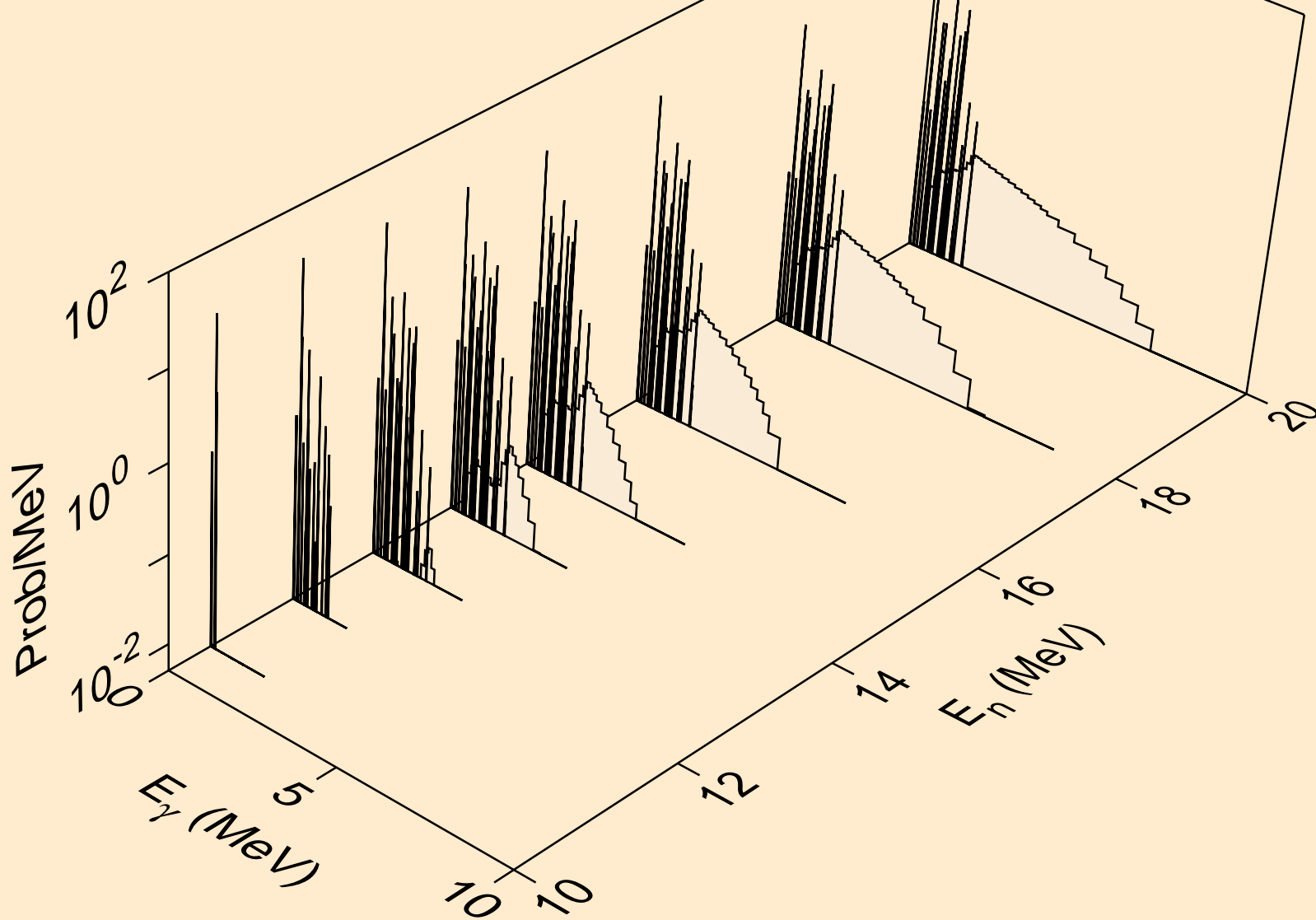

26-FE-58 FOR FENDL-3.2 FROM JEFF-3.1.1 BY NJOY2016.60+ ON
Photon emission for (n,3n)

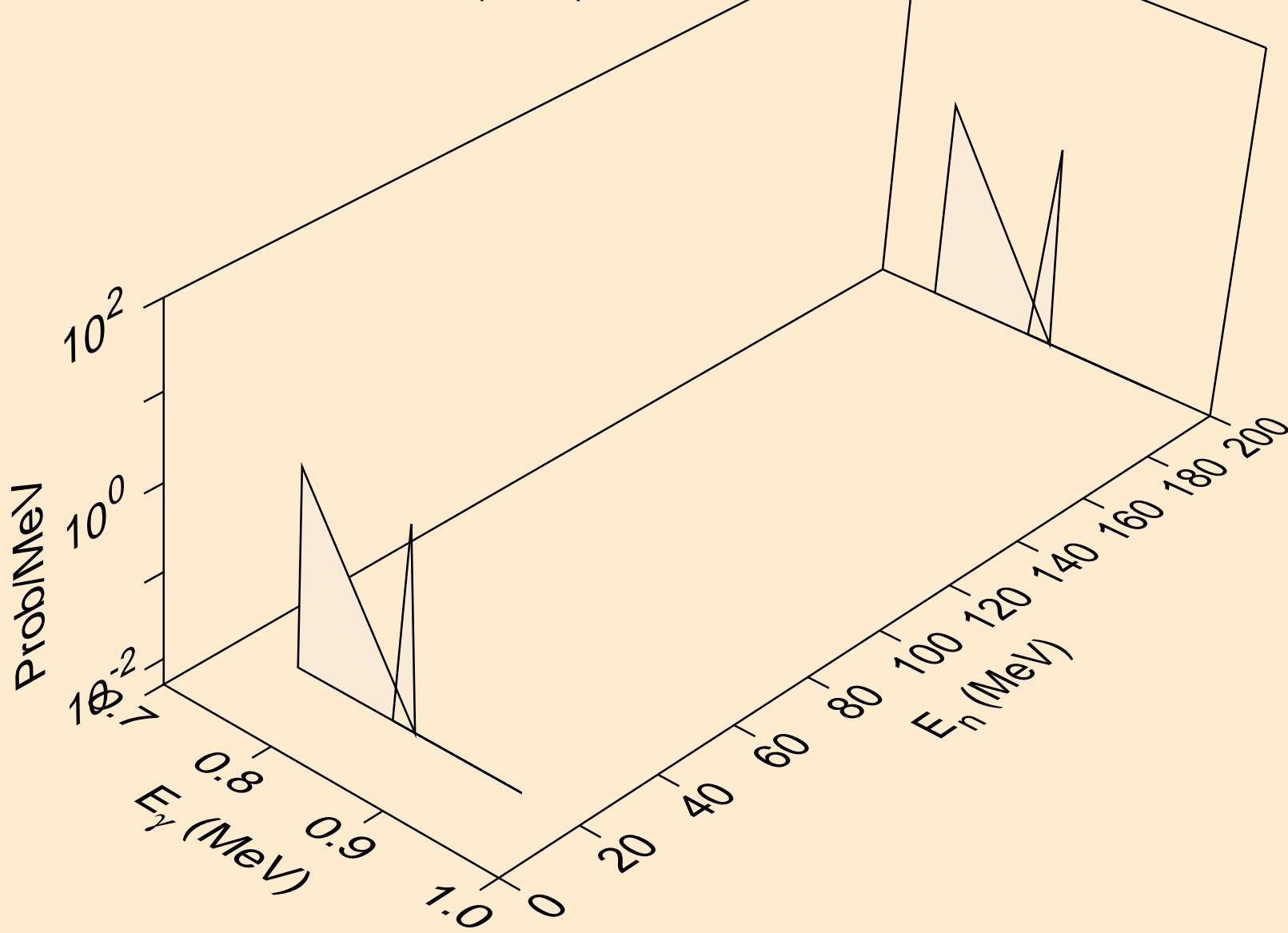

26-FE-58 FOR FENDL-3.2 FROM JEFF-3.1.1 BY NJOY2016.60+ ON
Photon emission for (n,n*)a

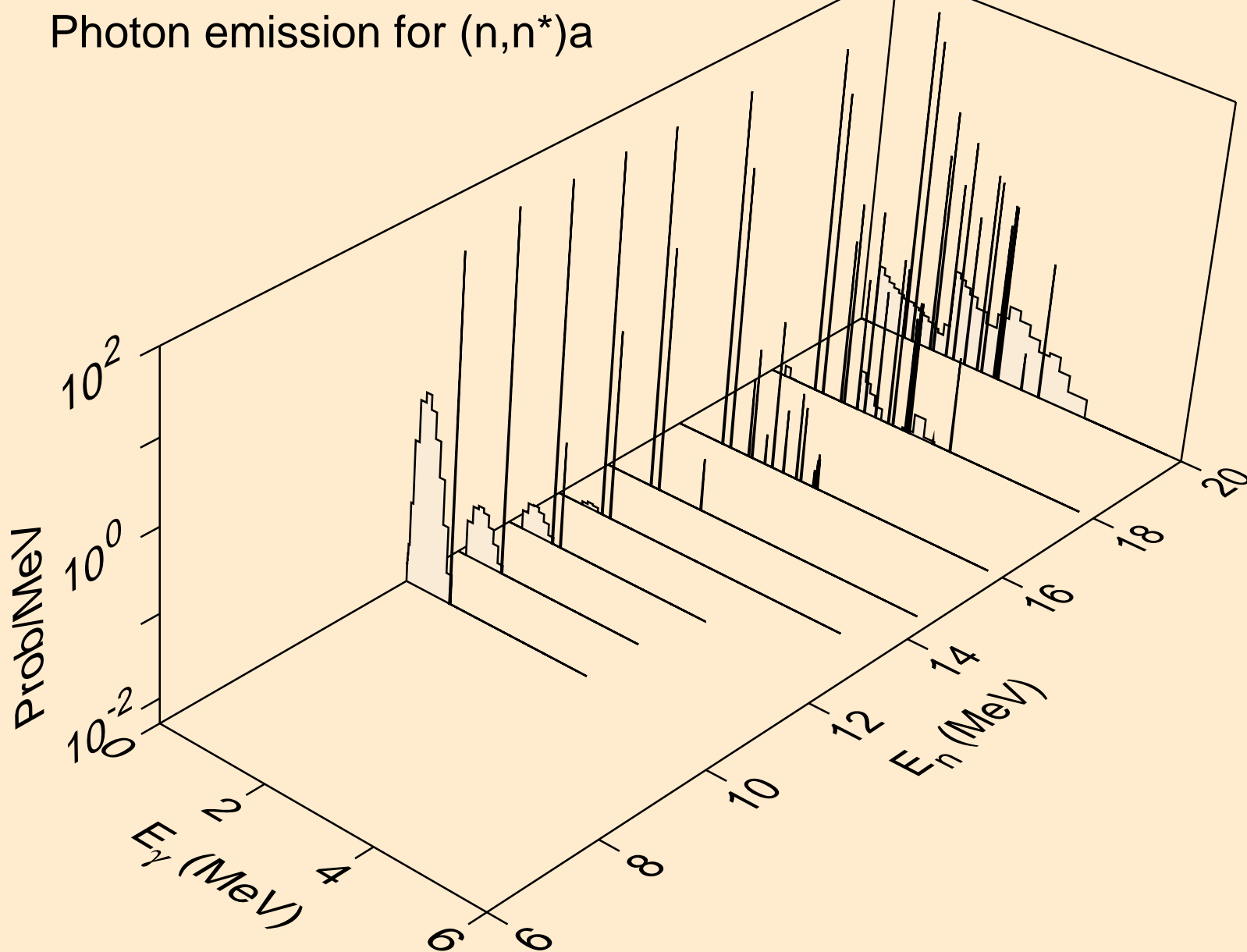

26-FE-58 FOR FENDL-3.2 FROM JEFF-3.1.1 BY NJOY2016.60+ ON
Photon emission for (n,n*)p

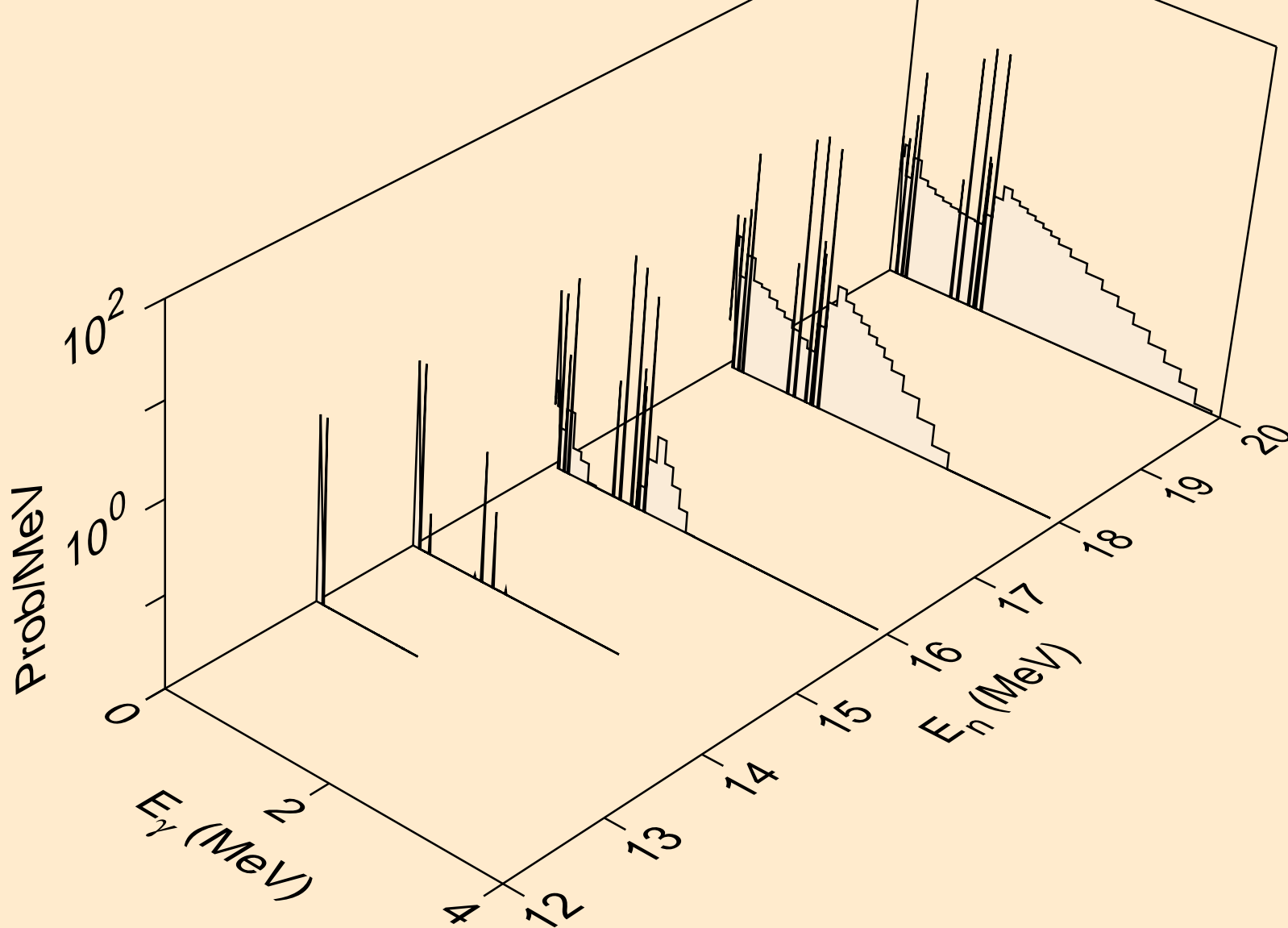

26-FE-58 FOR FENDL-3.2 FROM JEFF-3.1.1 BY NJOY2016.60+ ON
Photon emission for (n,n*1)

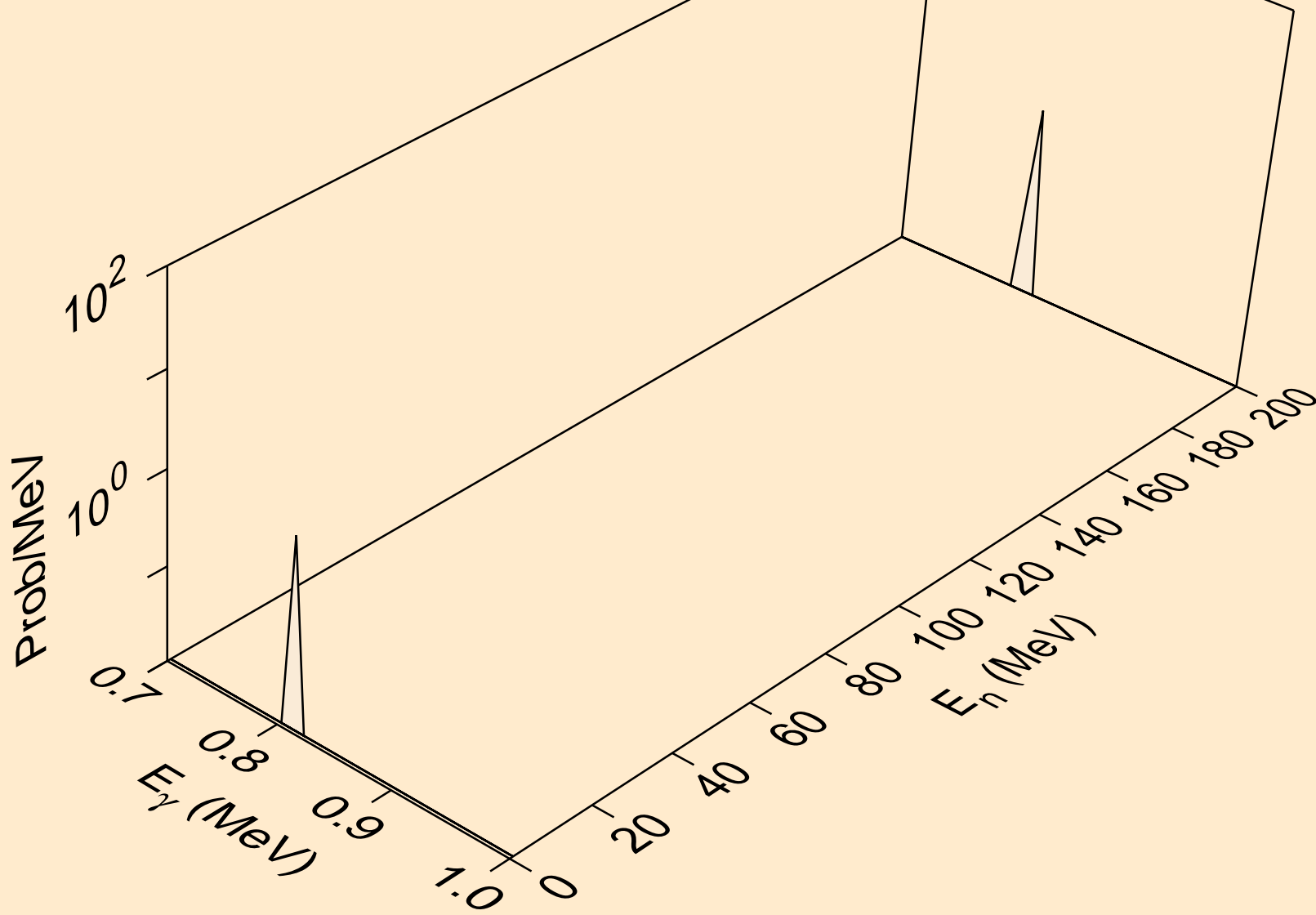

26-FE-58 FOR FENDL-3.2 FROM JEFF-3.1.1 BY NJOY2016.60+ ON
Photon emission for (n,n*2)

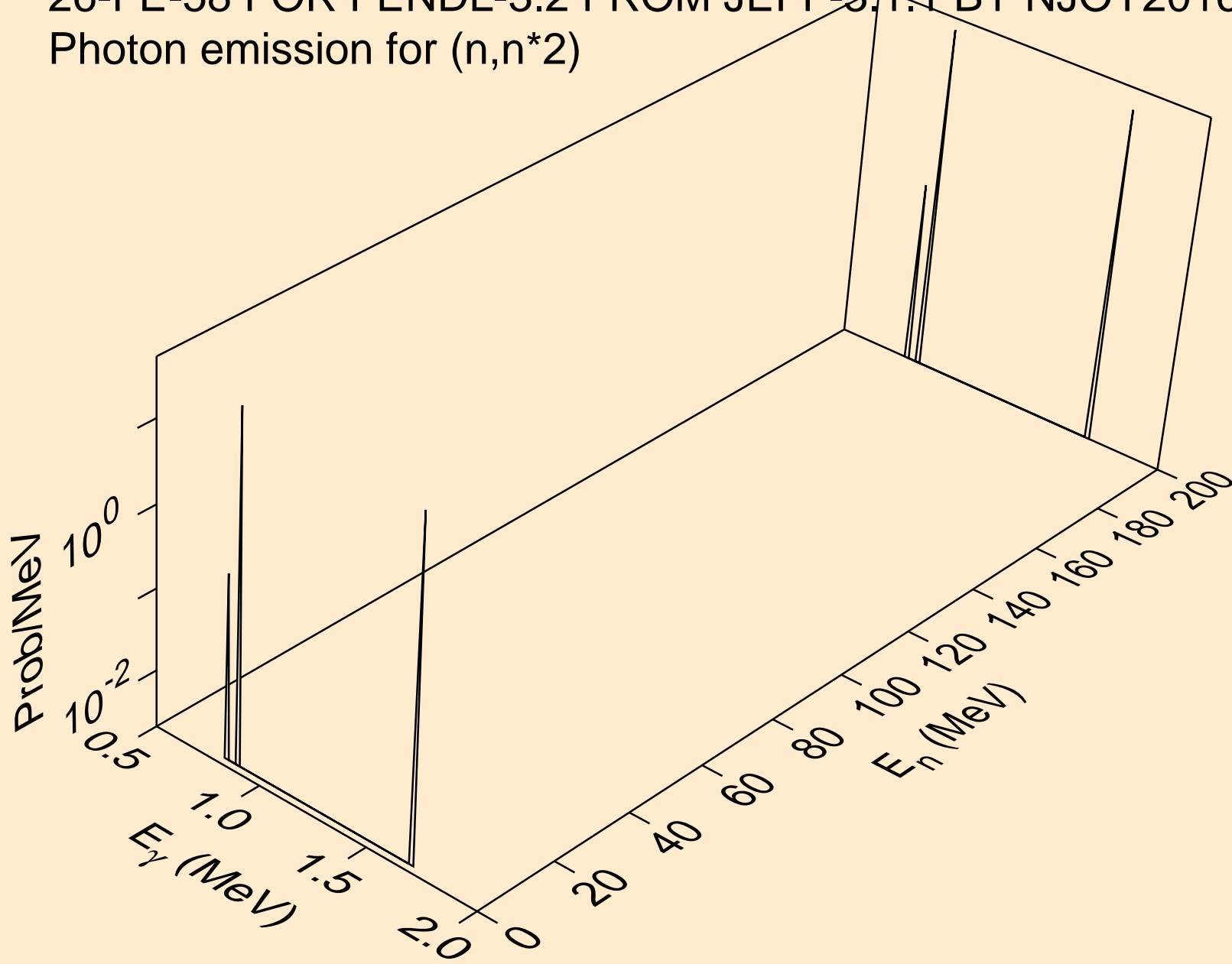

26-FE-58 FOR FENDL-3.2 FROM JEFF-3.1.1 BY NJOY2016.60+ ON
Photon emission for (n,n*3)

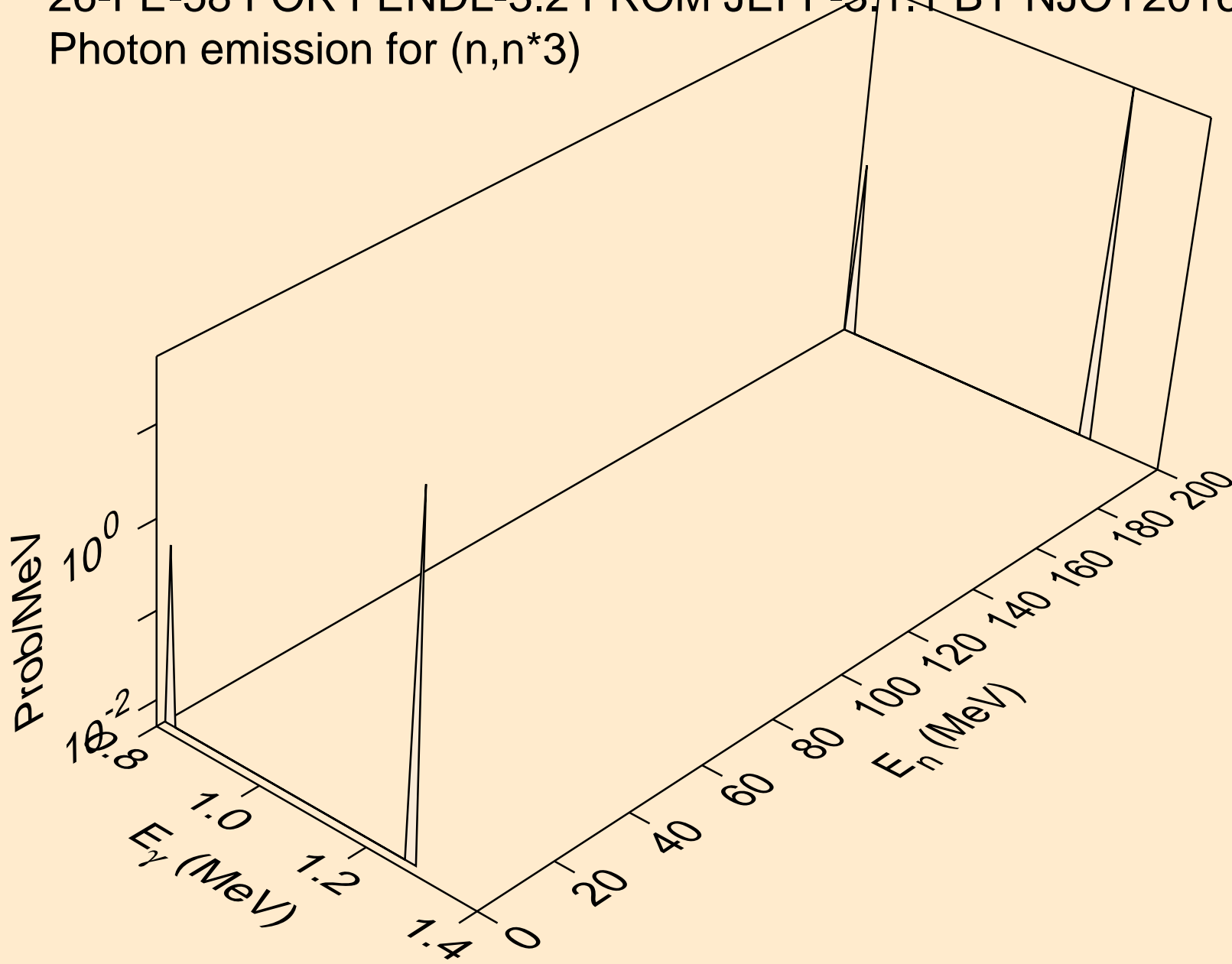

26-FE-58 FOR FENDL-3.2 FROM JEFF-3.1.1 BY NJOY2016.60+ ON
Photon emission for (n,n*4)

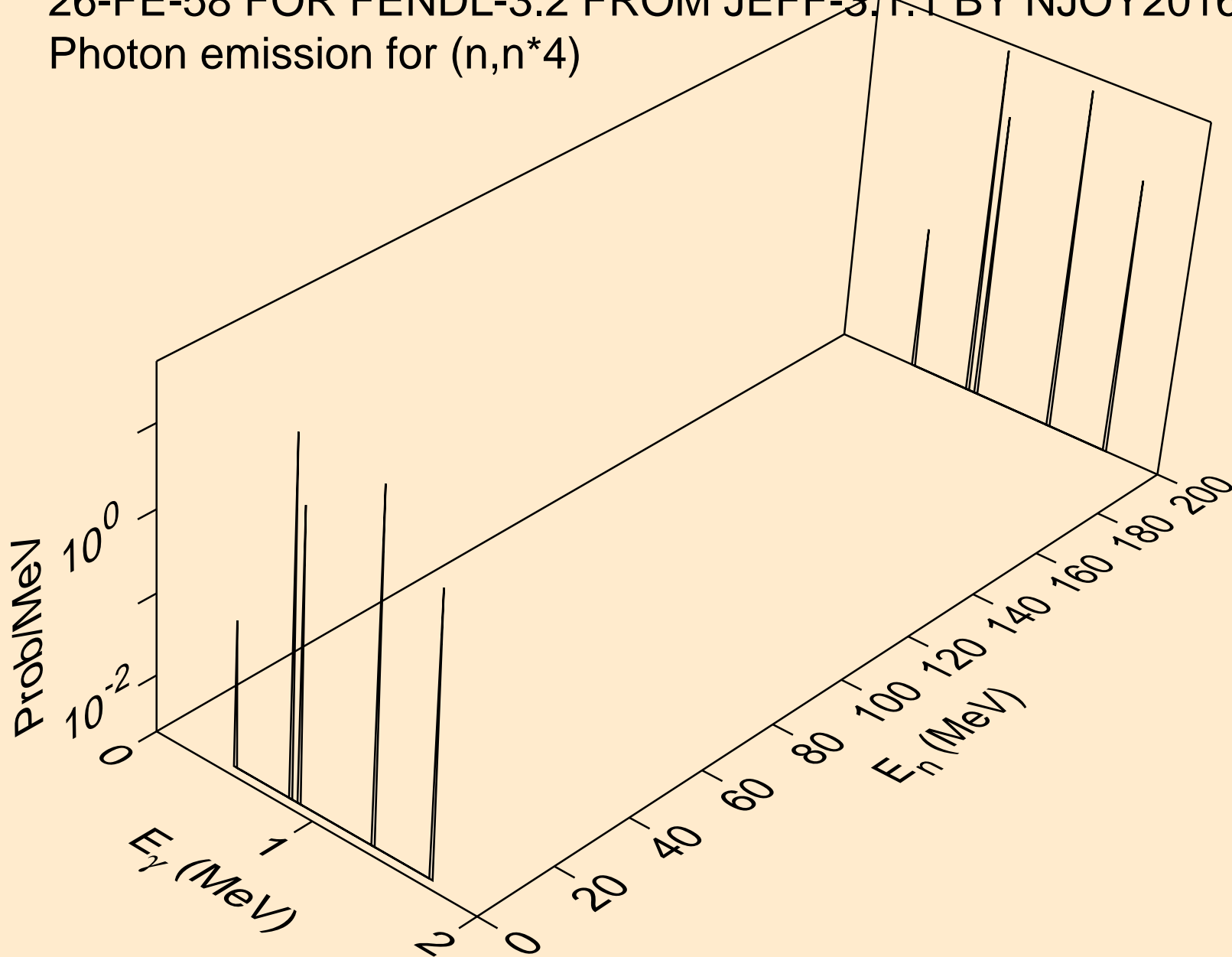

26-FE-58 FOR FENDL-3.2 FROM JEFF-3.1.1 BY NJOY2016.60+ ON
Photon emission for (n,n*5)

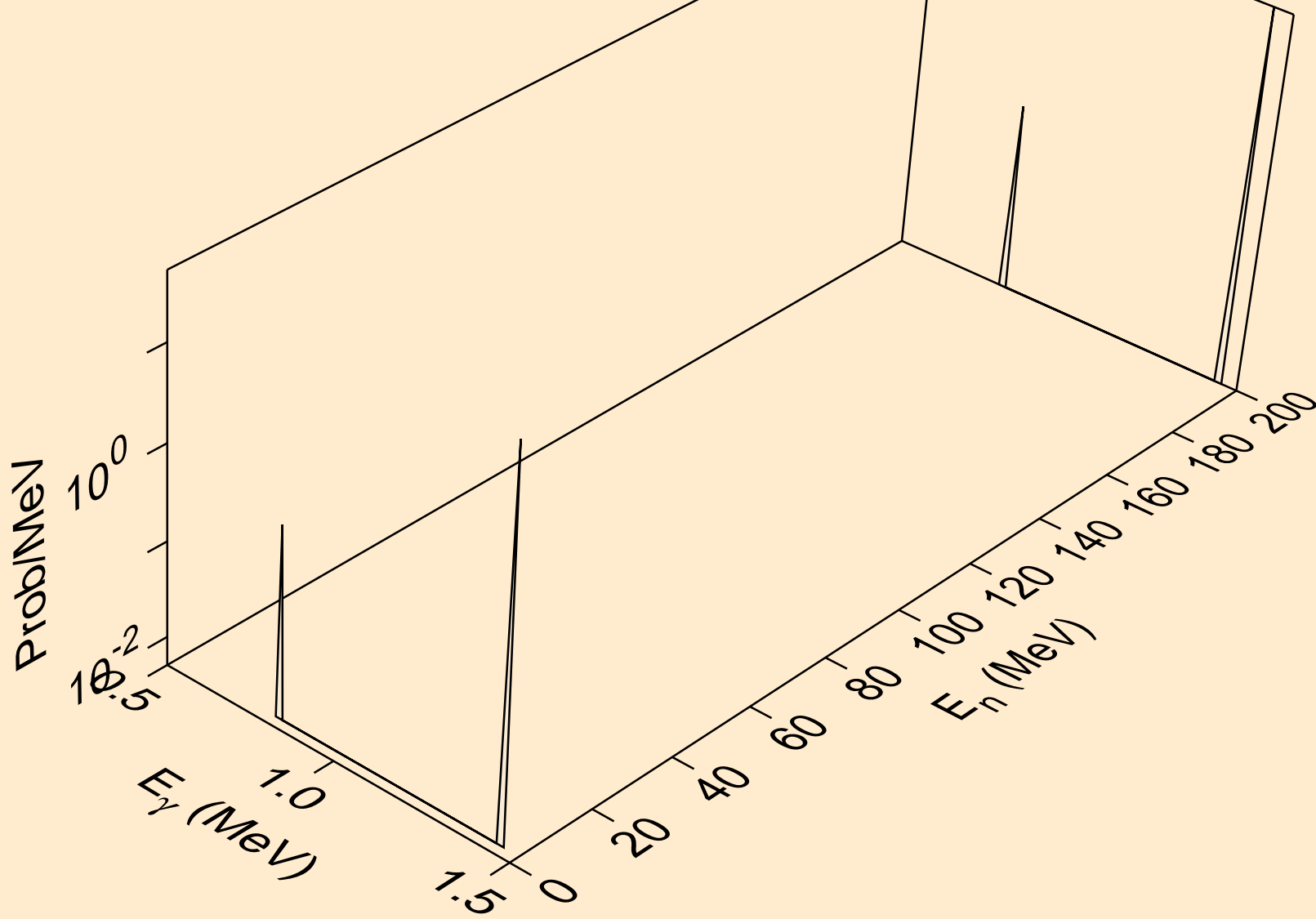

26-FE-58 FOR FENDL-3.2 FROM JEFF-3.1.1 BY NJOY2016.60+ ON
Photon emission for (n,n*6)

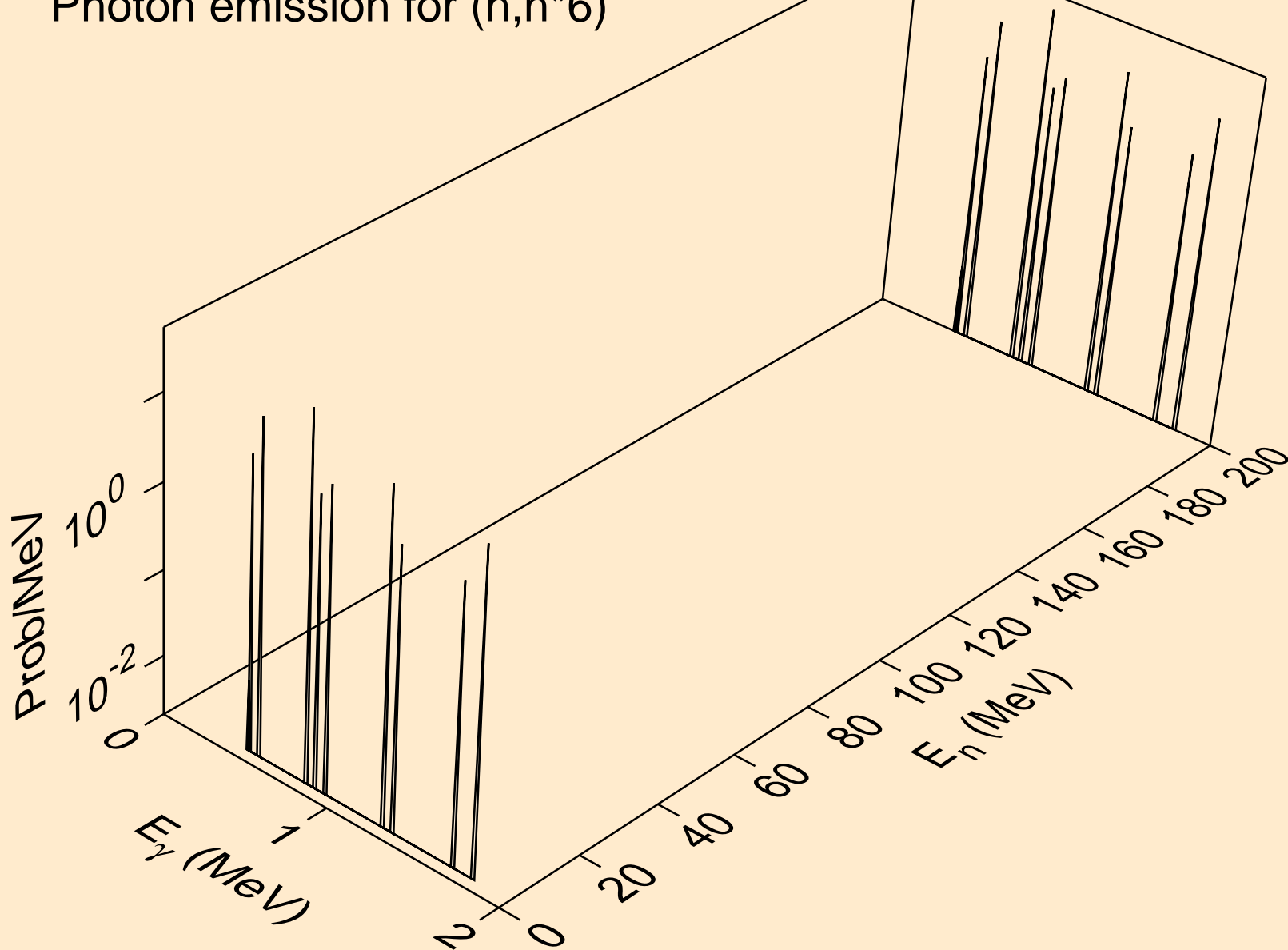

26-FE-58 FOR FENDL-3.2 FROM JEFF-3.1.1 BY NJOY2016.60+ ON
Photon emission for (n,n*7)

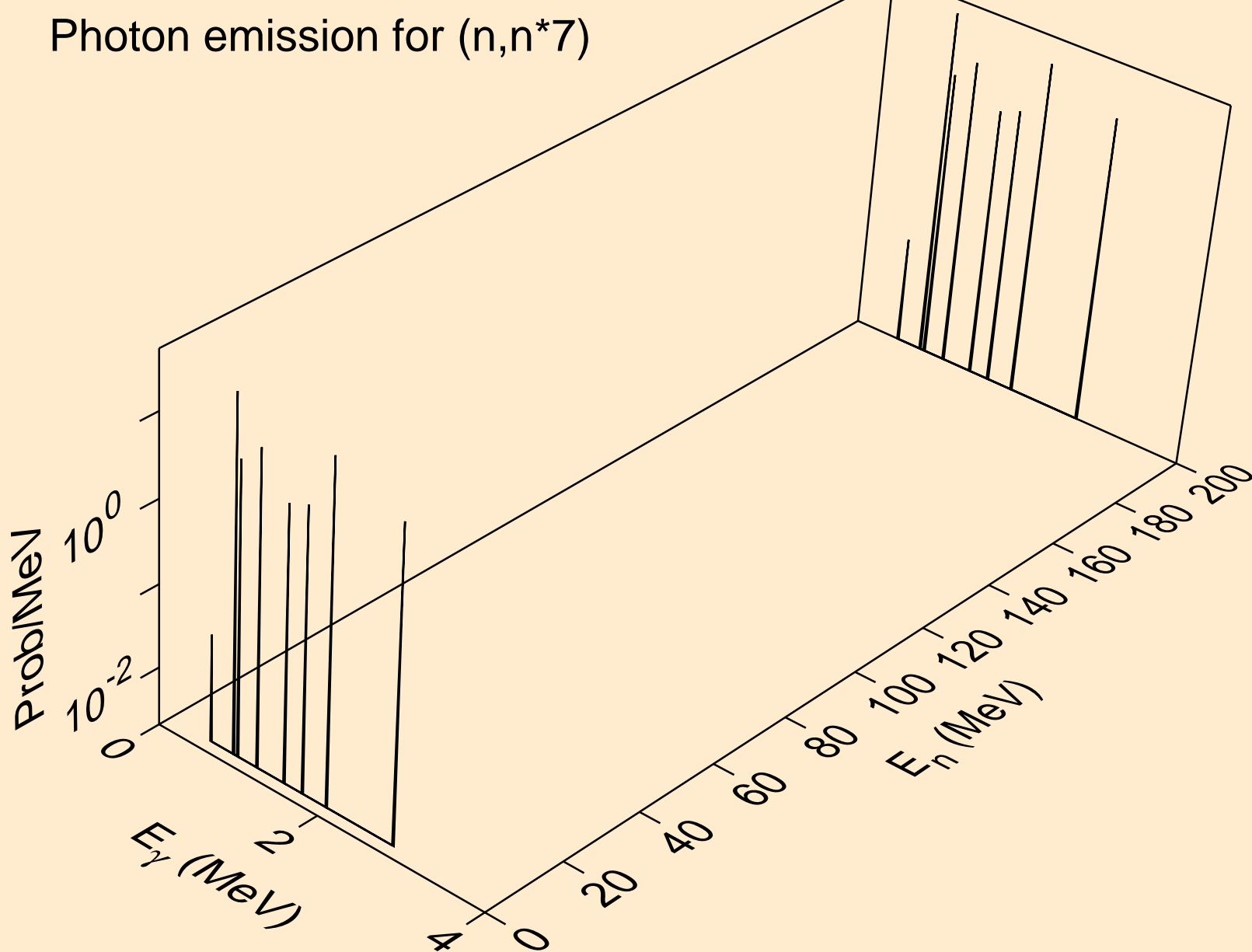

26-FE-58 FOR FENDL-3.2 FROM JEFF-3.1.1 BY NJOY2016.60+ ON
Photon emission for (n,n*8)

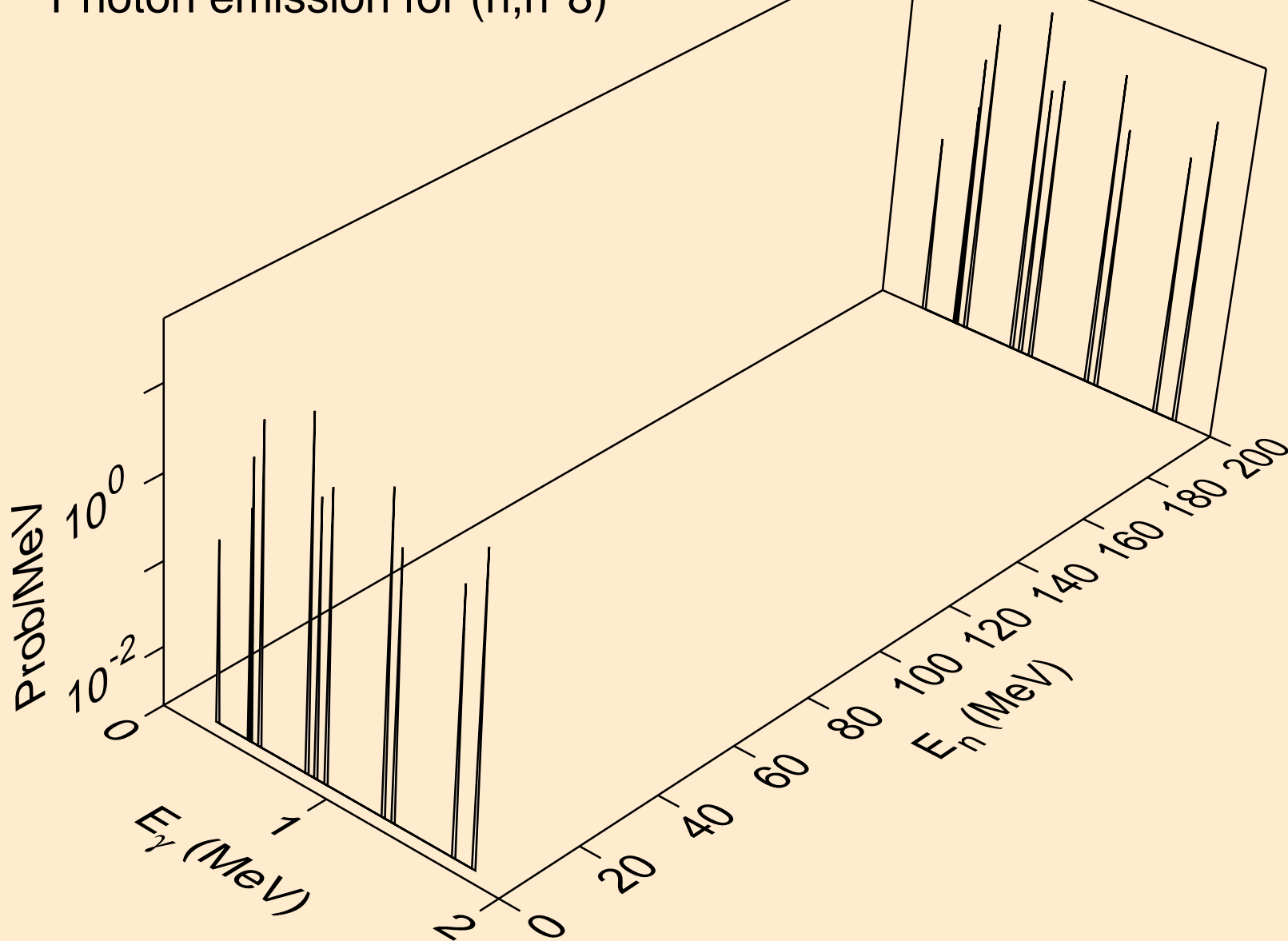

26-FE-58 FOR FENDL-3.2 FROM JEFF-3.1.1 BY NJOY2016.60+ ON
Photon emission for (n,n*9)

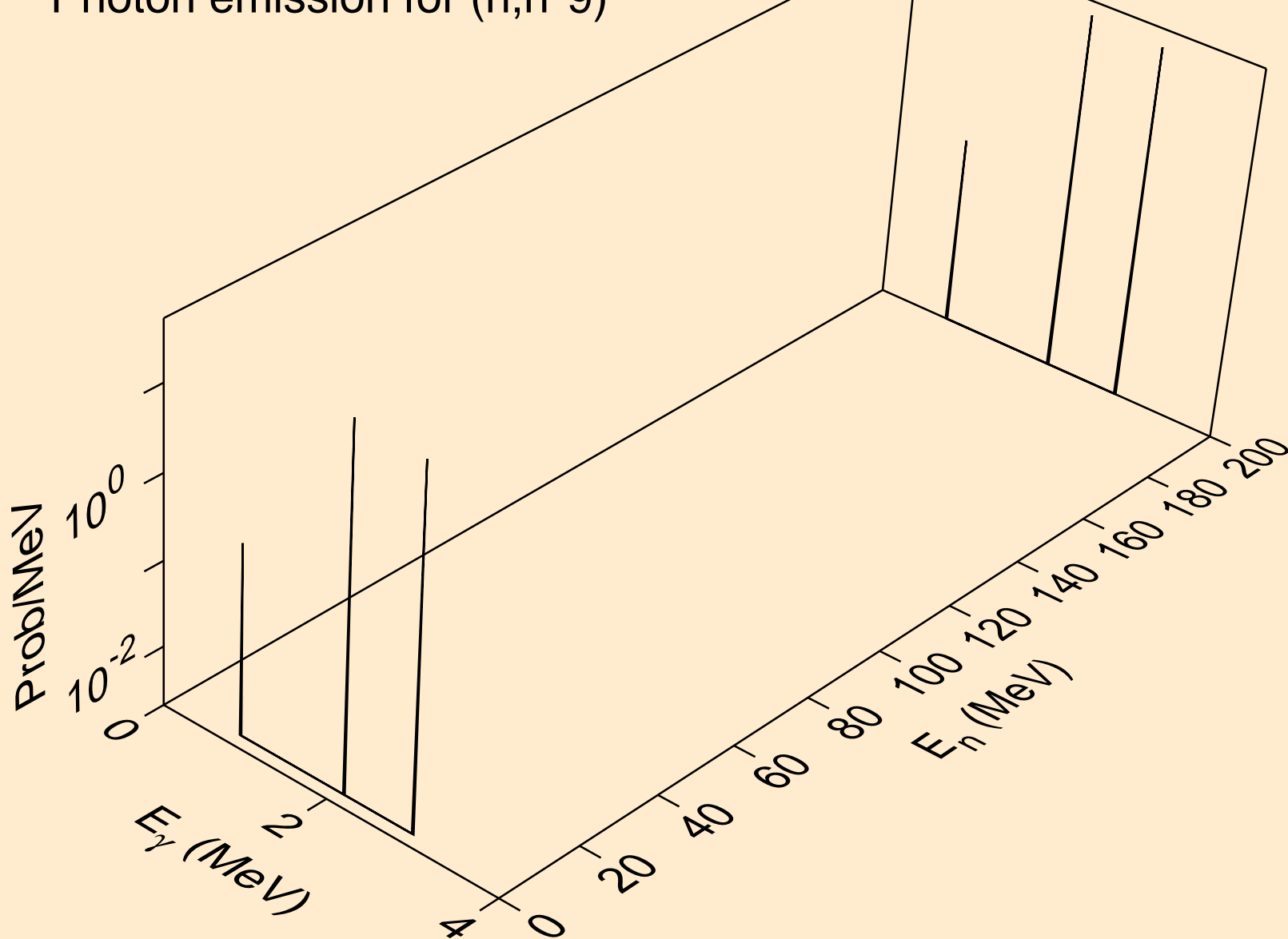

26-FE-58 FOR FENDL-3.2 FROM JEFF-3.1.1 BY NJOY2016.60+ ON
Photon emission for (n,n*10)

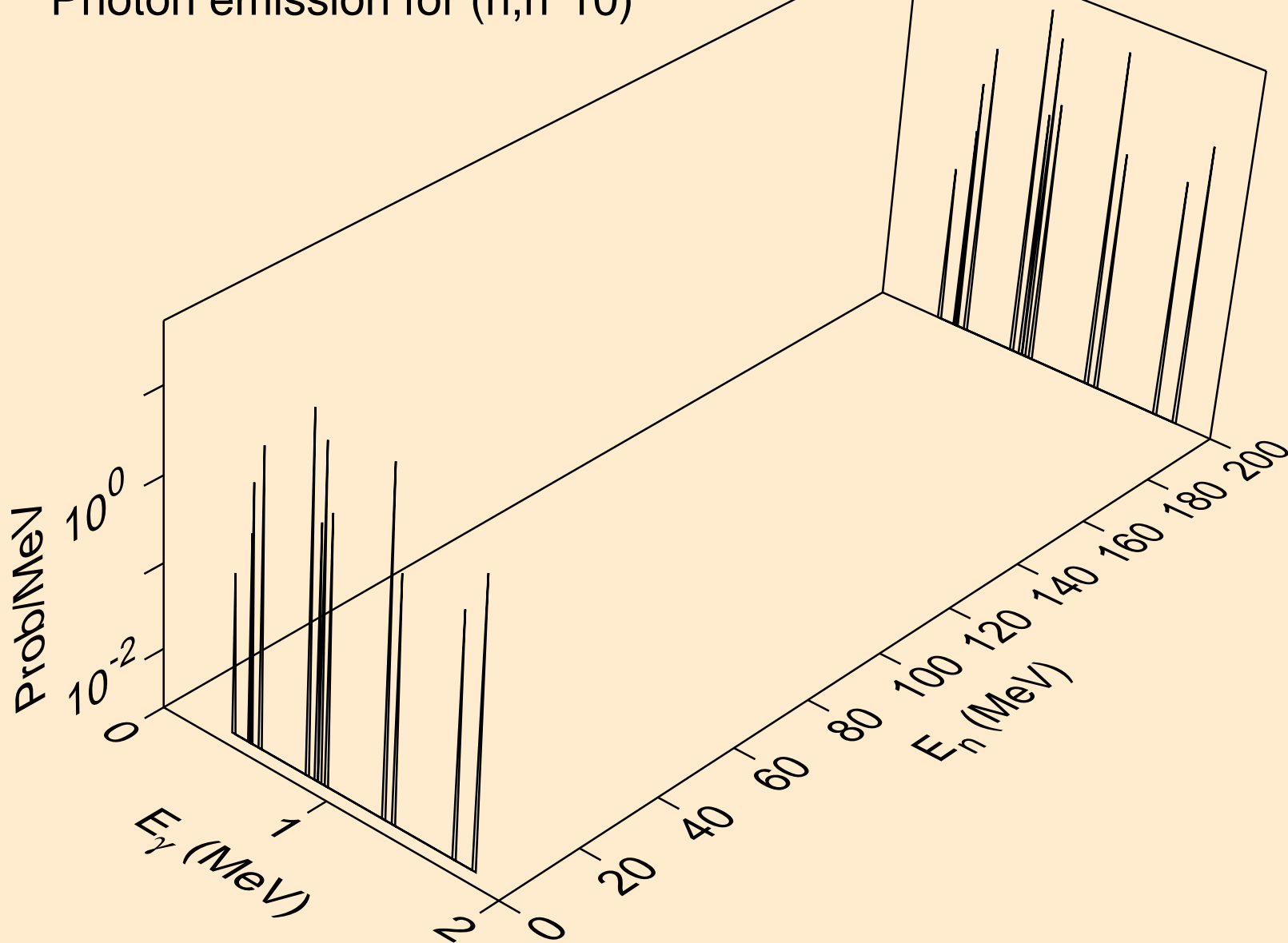

26-FE-58 FOR FENDL-3.2 FROM JEFF-3.1.1 BY NJOY2016.60+ ON
Photon emission for (n,n*11)

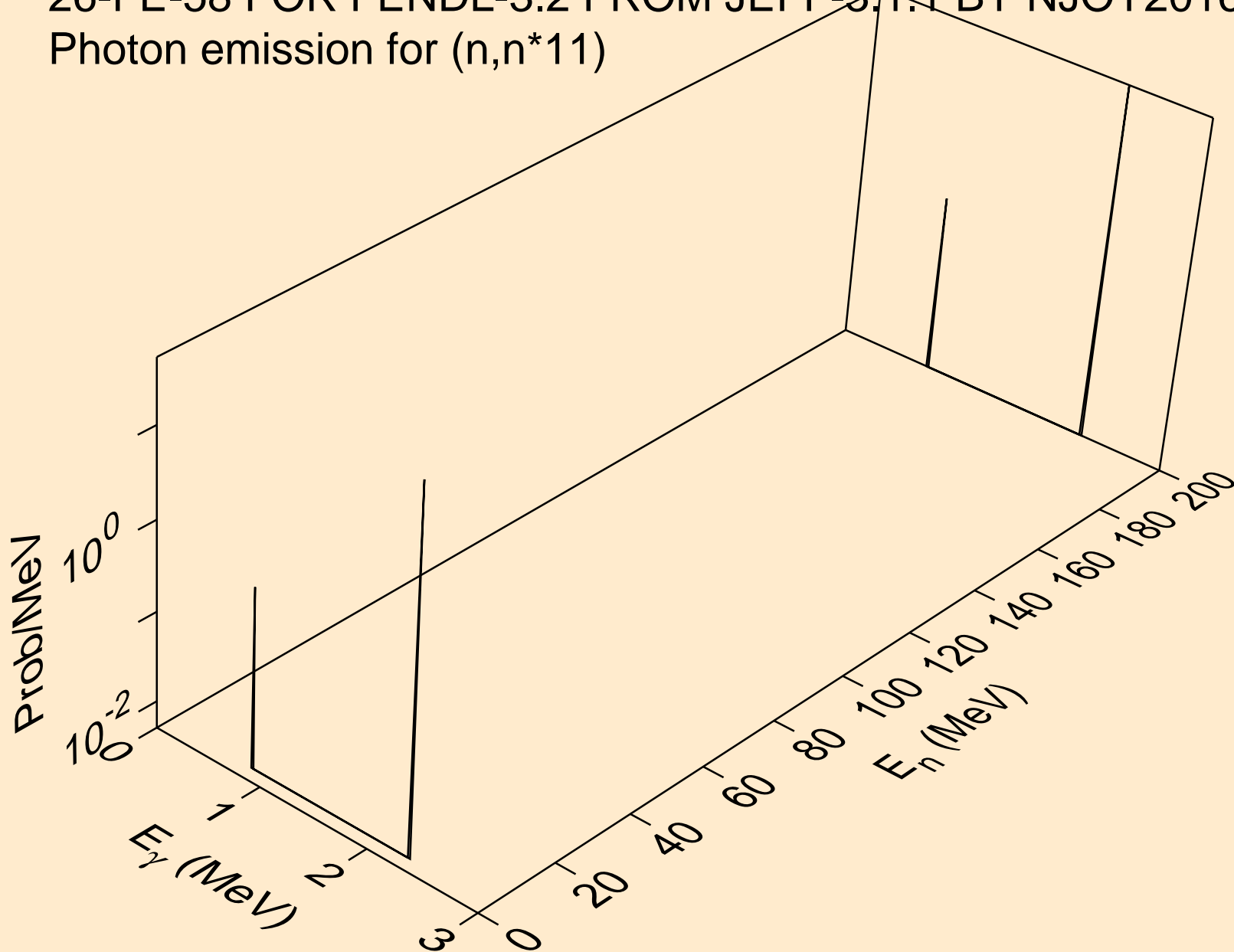

26-FE-58 FOR FENDL-3.2 FROM JEFF-3.1.1 BY NJOY2016.60+ ON
Photon emission for (n,n*12)

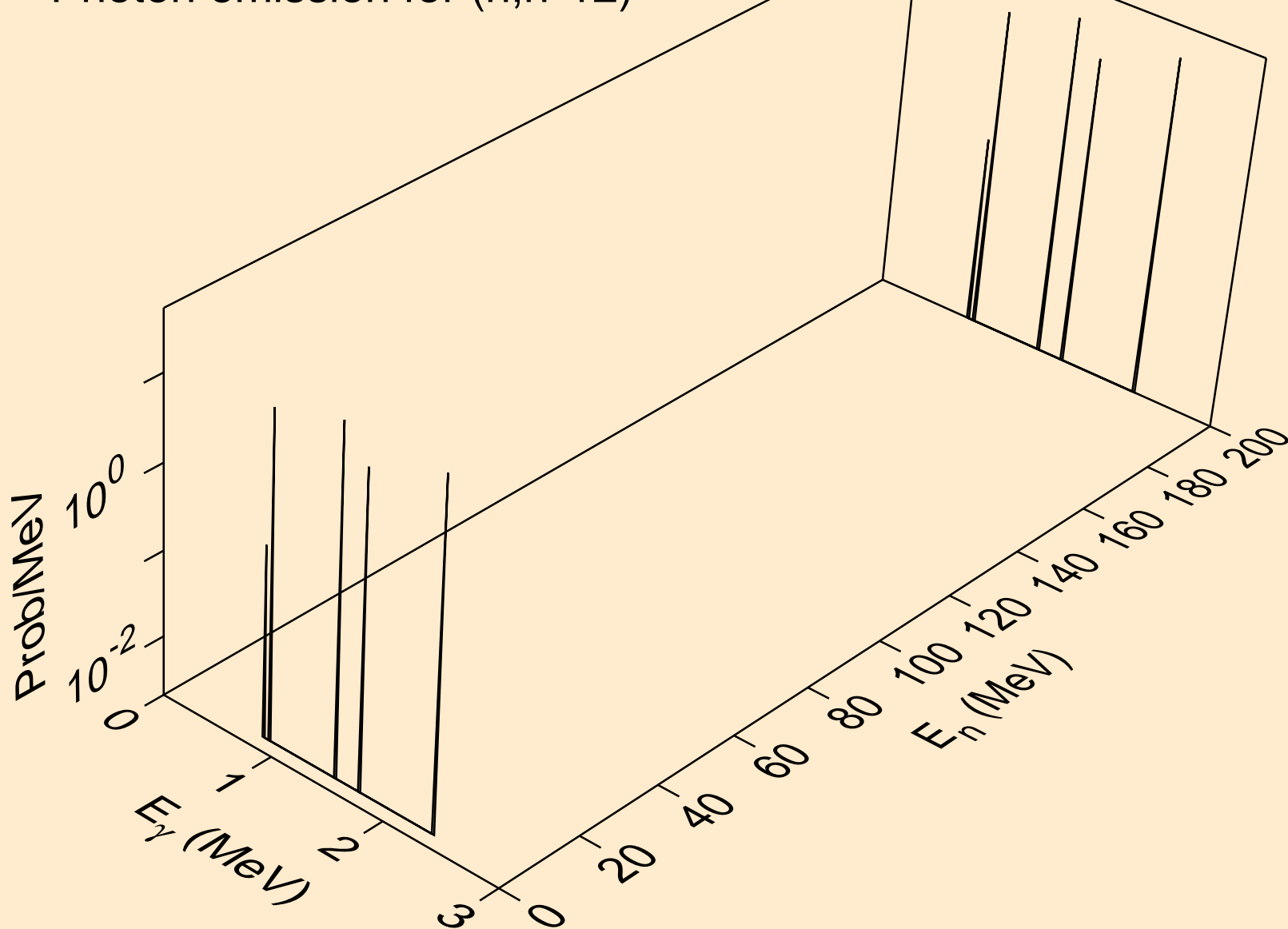

26-FE-58 FOR FENDL-3.2 FROM JEFF-3.1.1 BY NJOY2016.60+ ON
Photon emission for (n,n*13)

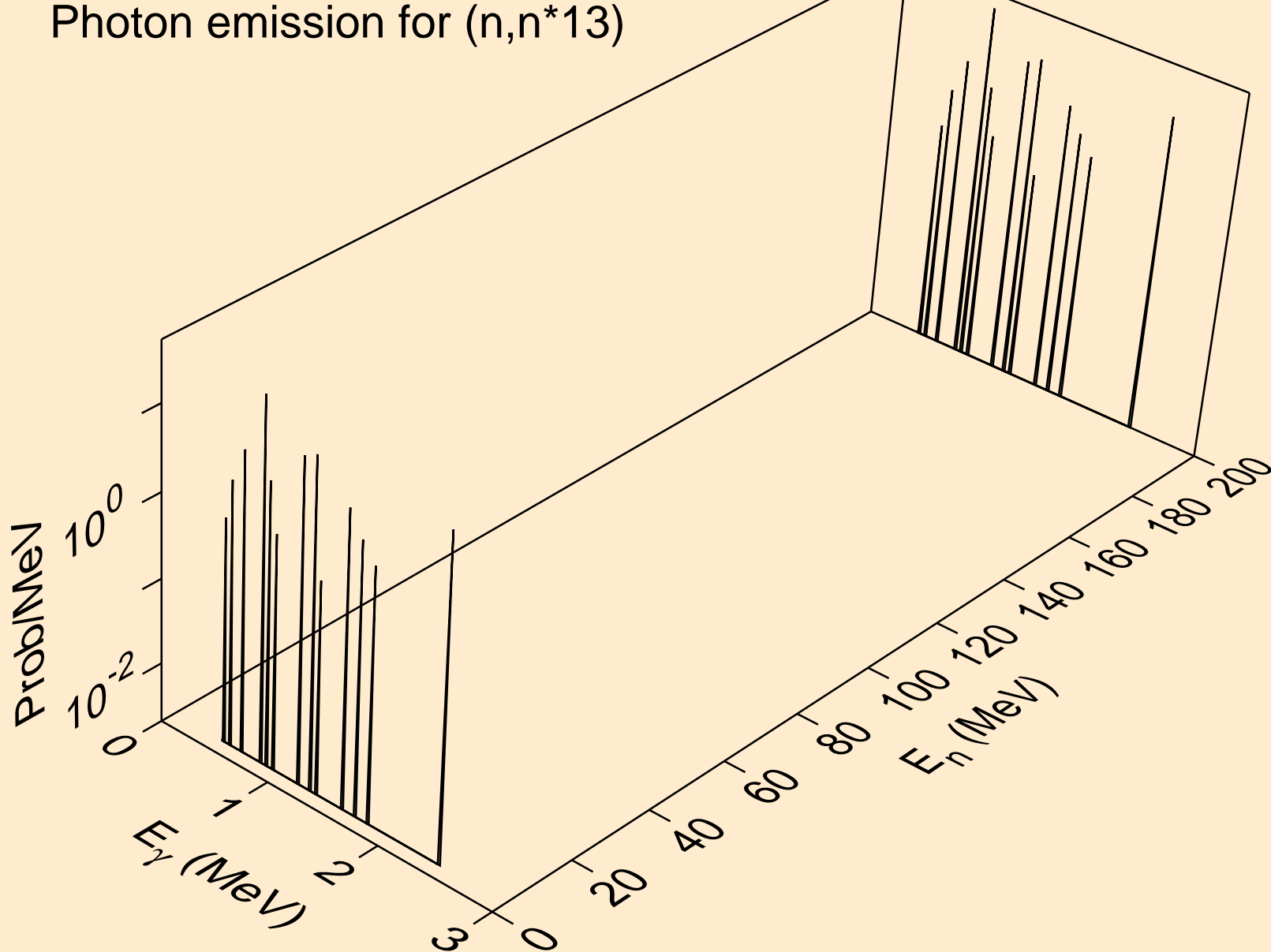

26-FE-58 FOR FENDL-3.2 FROM JEFF-3.1.1 BY NJOY2016.60+ ON
Photon emission for (n,n*14)

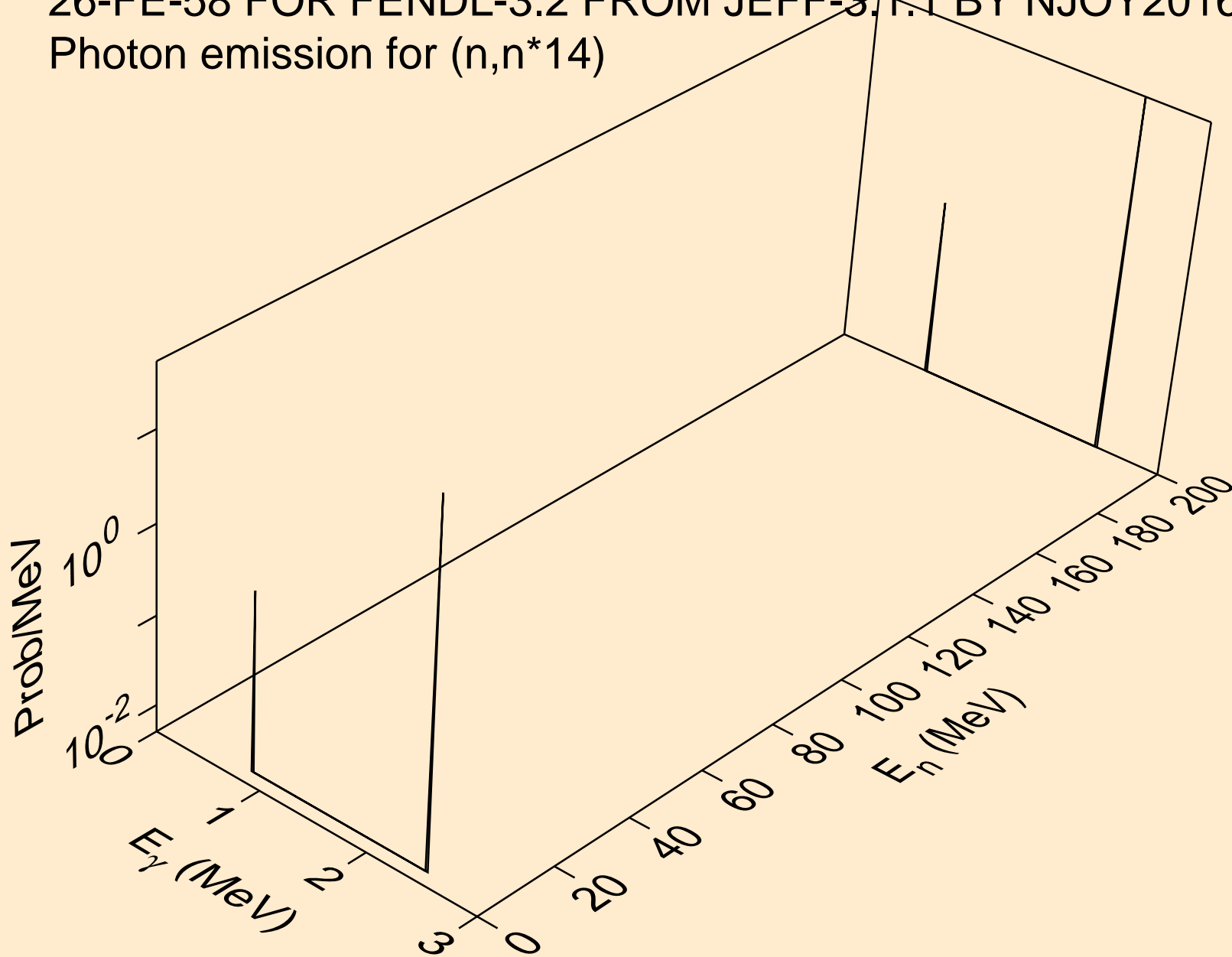

26-FE-58 FOR FENDL-3.2 FROM JEFF-3.1.1 BY NJOY2016.60+ ON
Photon emission for (n,n*15)

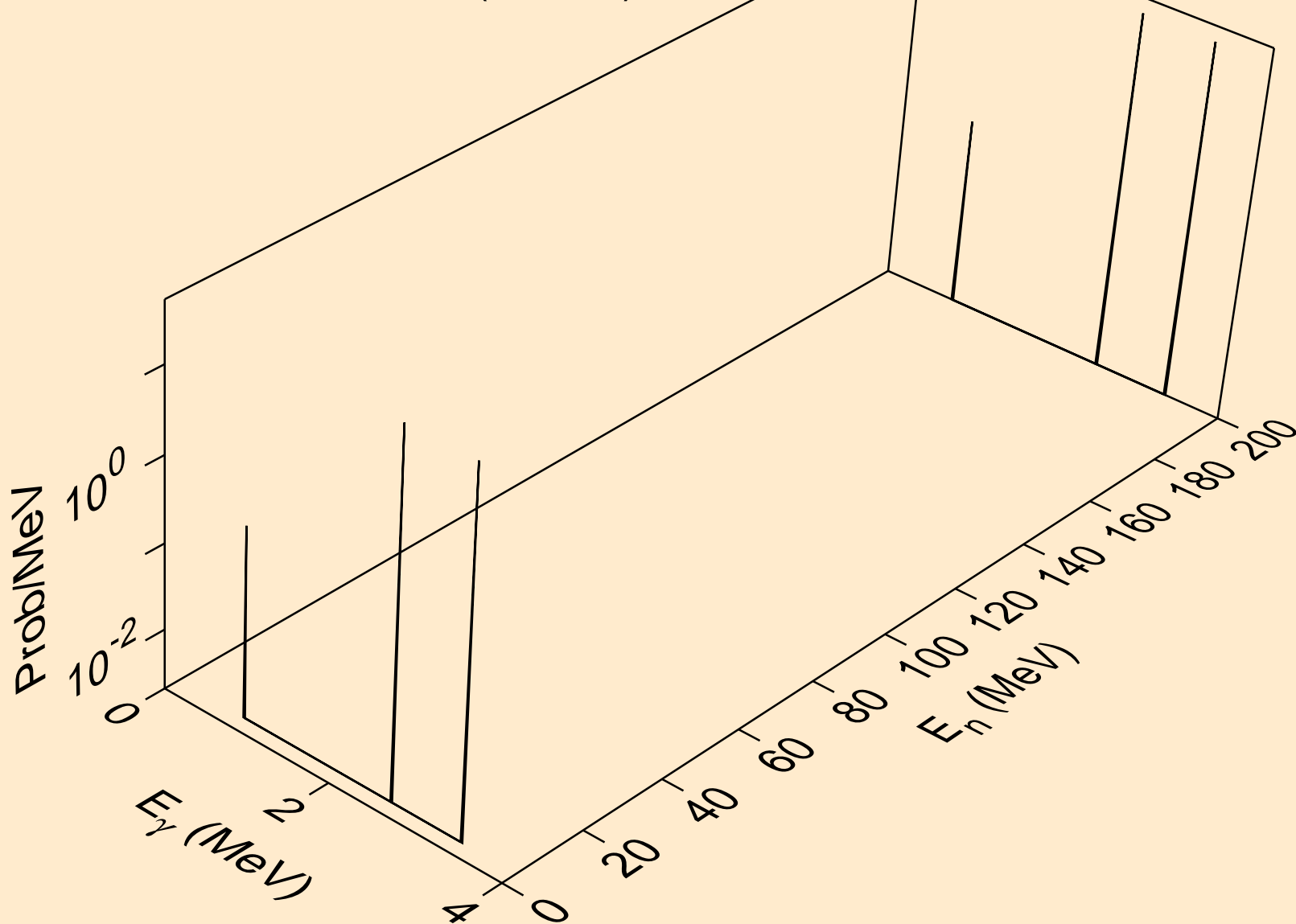

26-FE-58 FOR FENDL-3.2 FROM JEFF-3.1.1 BY NJOY2016.60+ ON
Photon emission for (n,n*16)

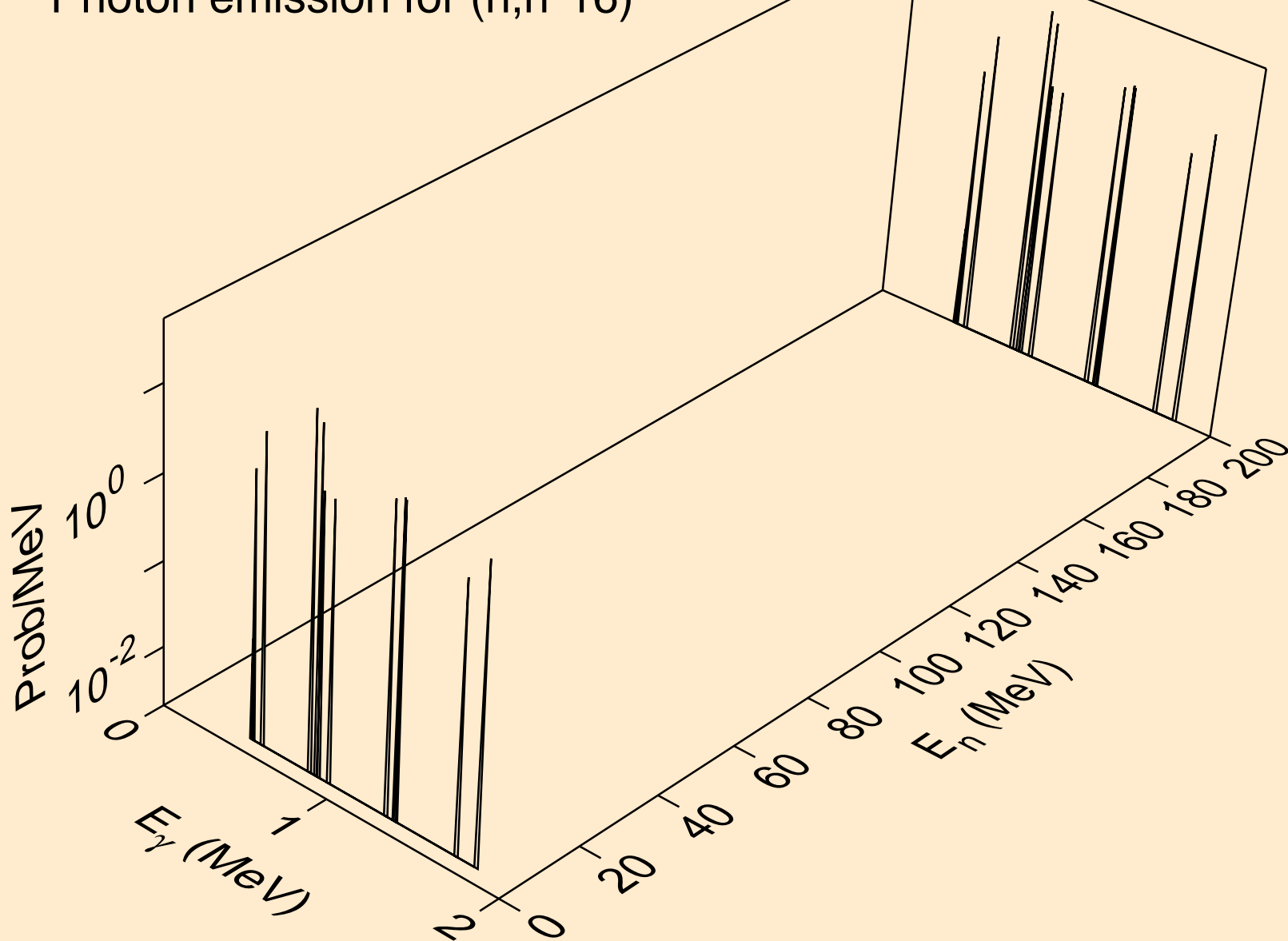

26-FE-58 FOR FENDL-3.2 FROM JEFF-3.1.1 BY NJOY2016.60+ ON
Photon emission for (n,n*17)

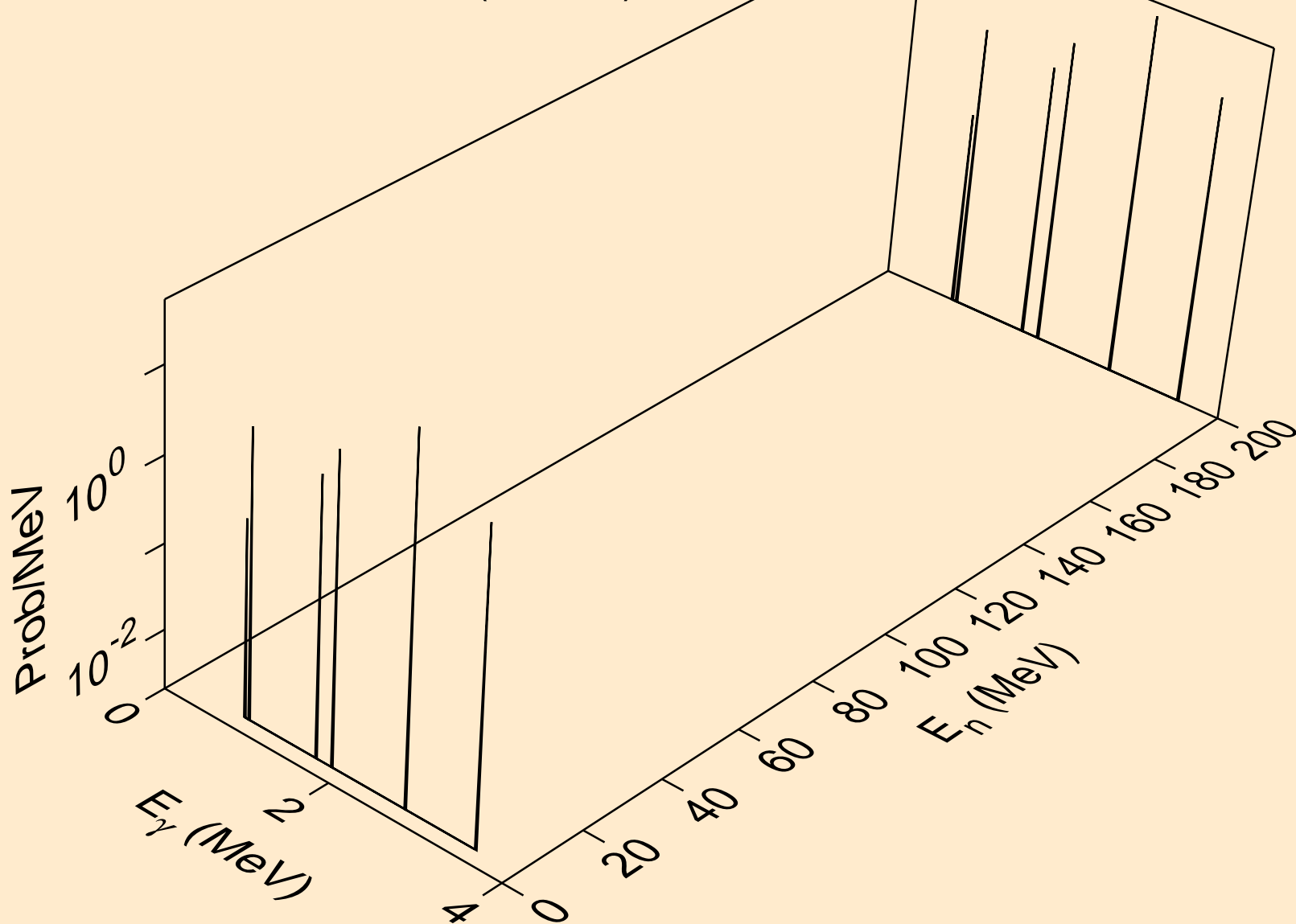

26-FE-58 FOR FENDL-3.2 FROM JEFF-3.1.1 BY NJOY2016.60+ ON
Photon emission for (n,n*18)

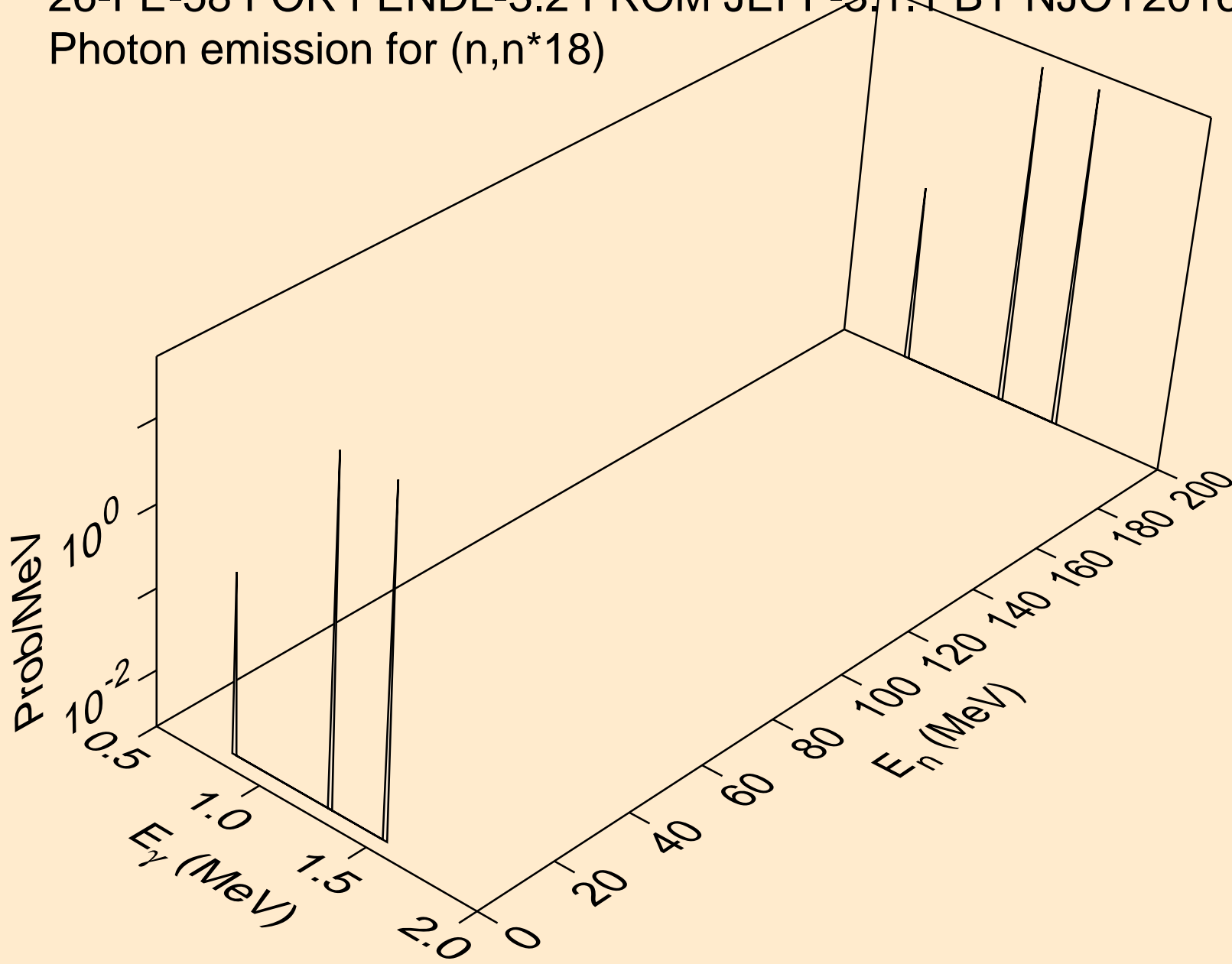

26-FE-58 FOR FENDL-3.2 FROM JEFF-3.1.1 BY NJOY2016.60+ ON
Photon emission for (n,n*19)

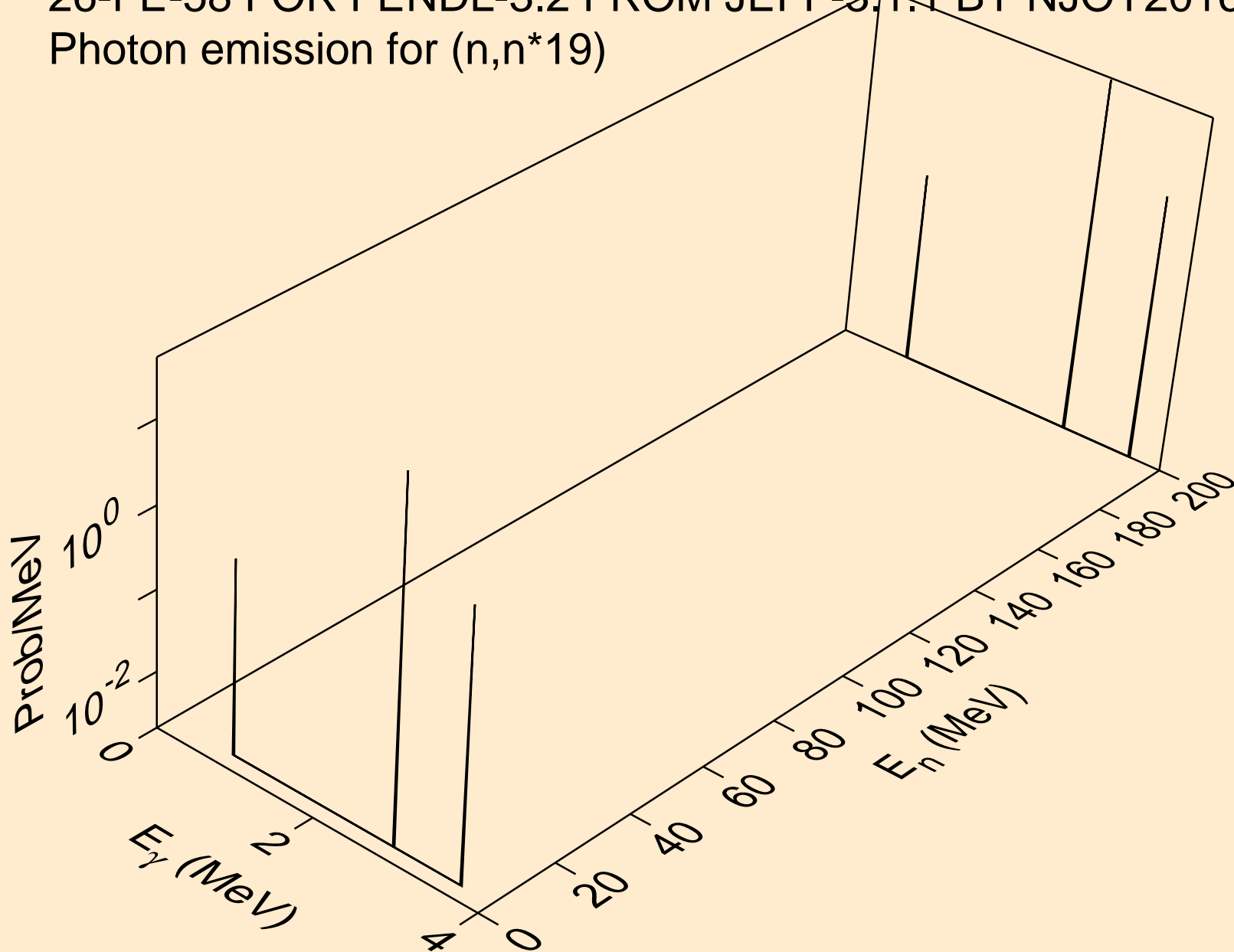

26-FE-58 FOR FENDL-3.2 FROM JEFF-3.1.1 BY NJOY2016.60+ ON
Photon emission for (n,n*20)

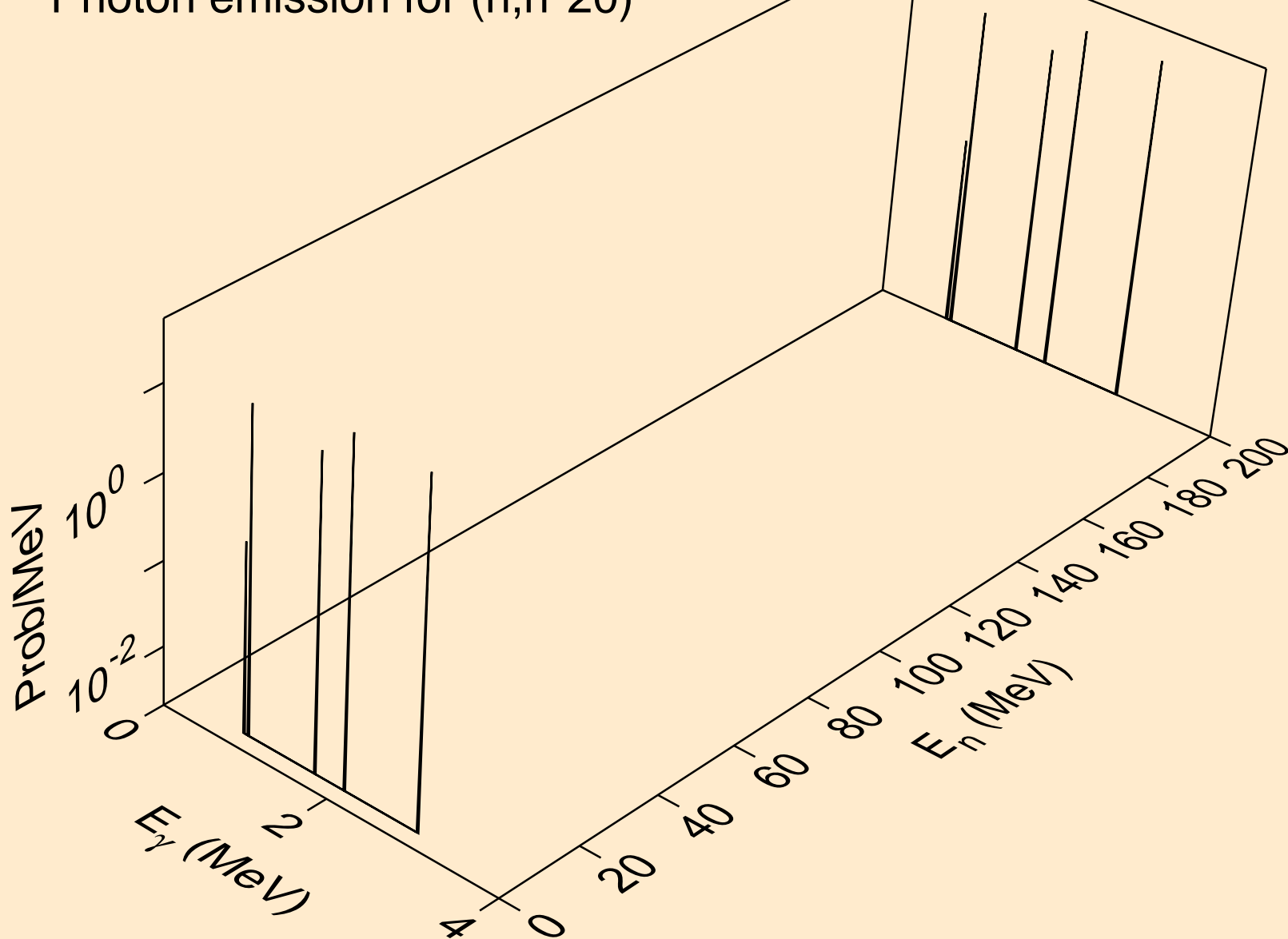

26-FE-58 FOR FENDL-3.2 FROM JEFF-3.1.1 BY NJOY2016.60+ ON
Photon emission for (n,n*c)

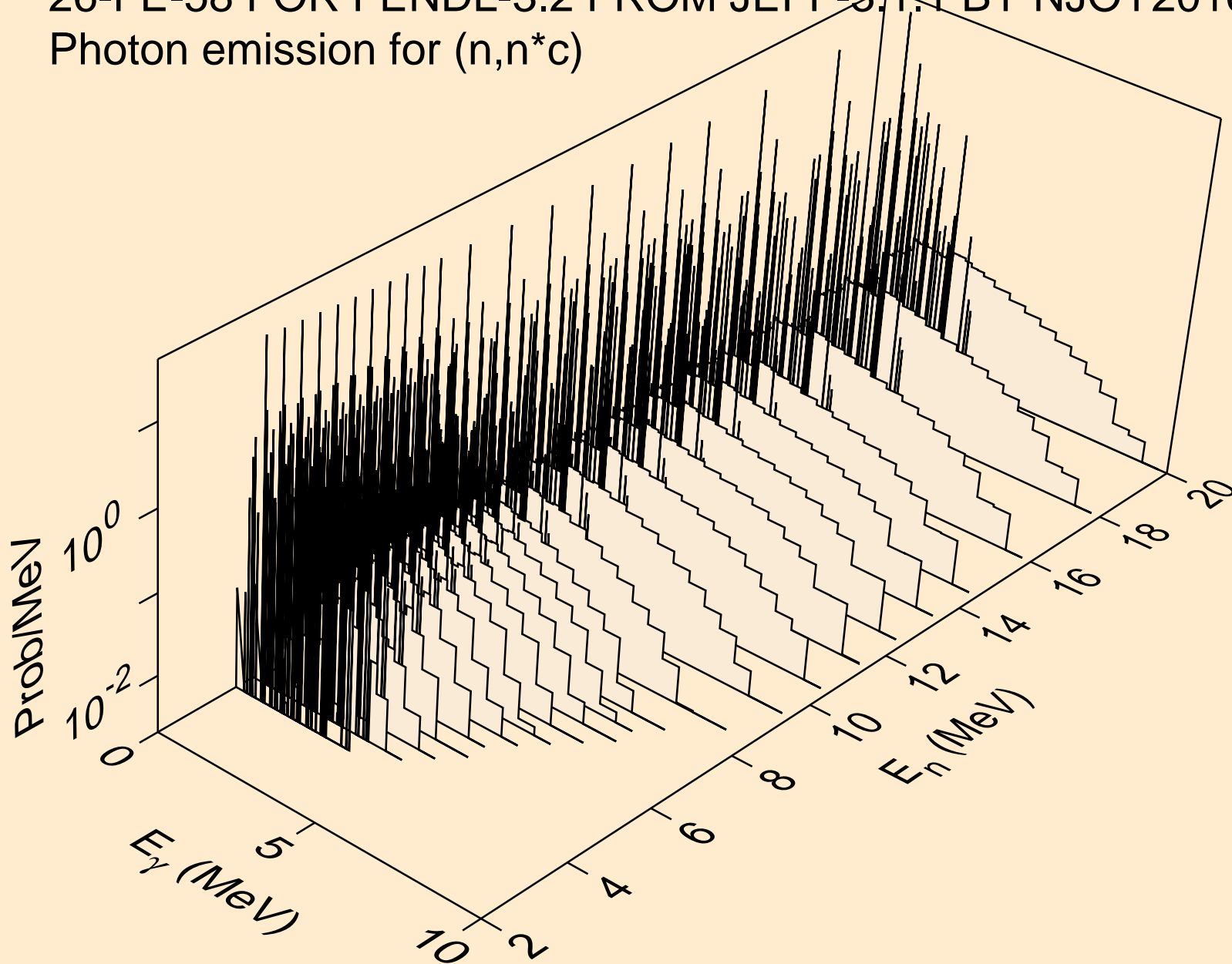

26-FE-58 FOR FENDL-3.2 FROM JEFF-3.1.1 BY NJOY2016.60+ ON
Photon emission for (n,gma)

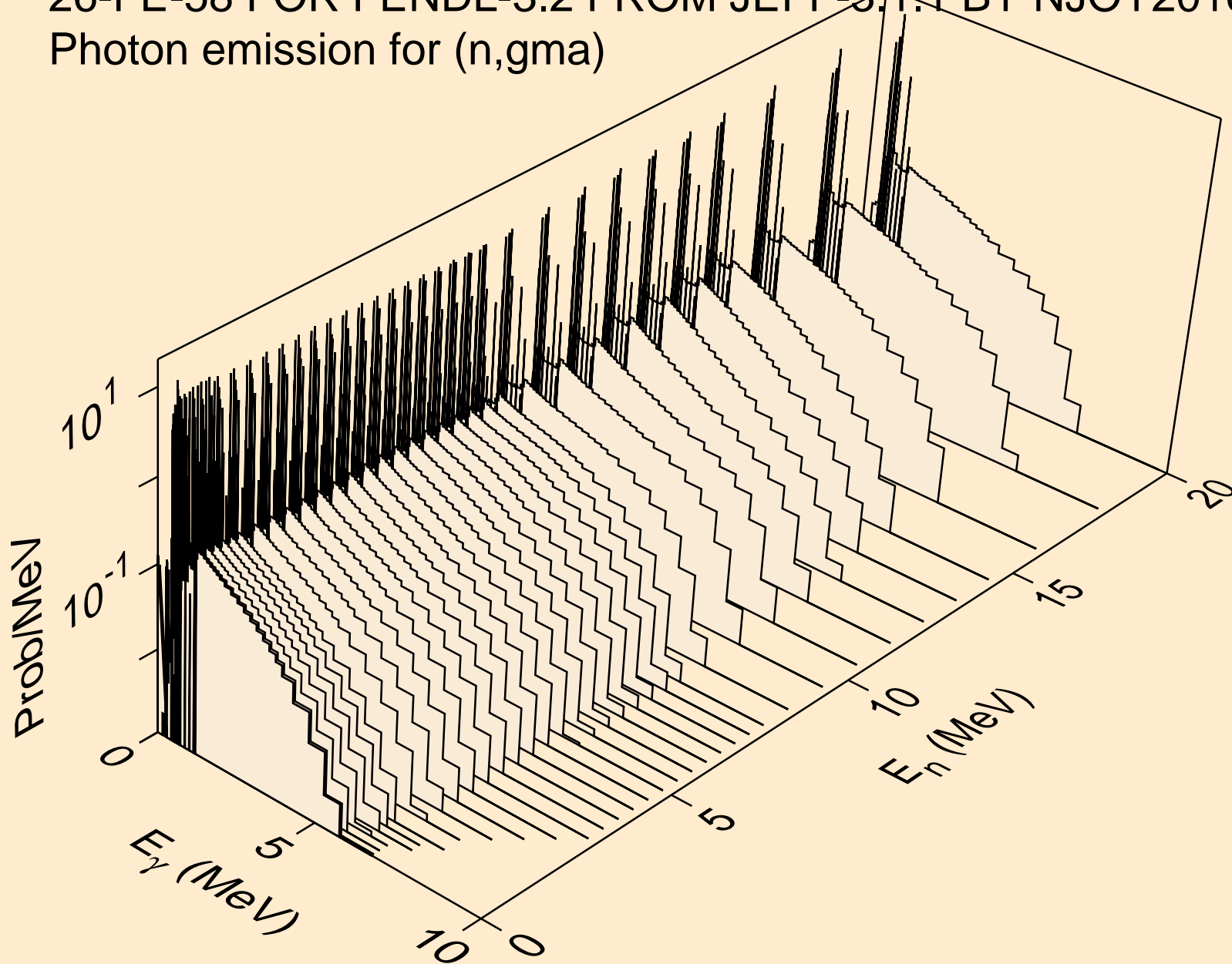

26-FE-58 FOR FENDL-3.2 FROM JEFF-3.1.1 BY NJOY2016.60+ ON
Photon emission for (n,2a)

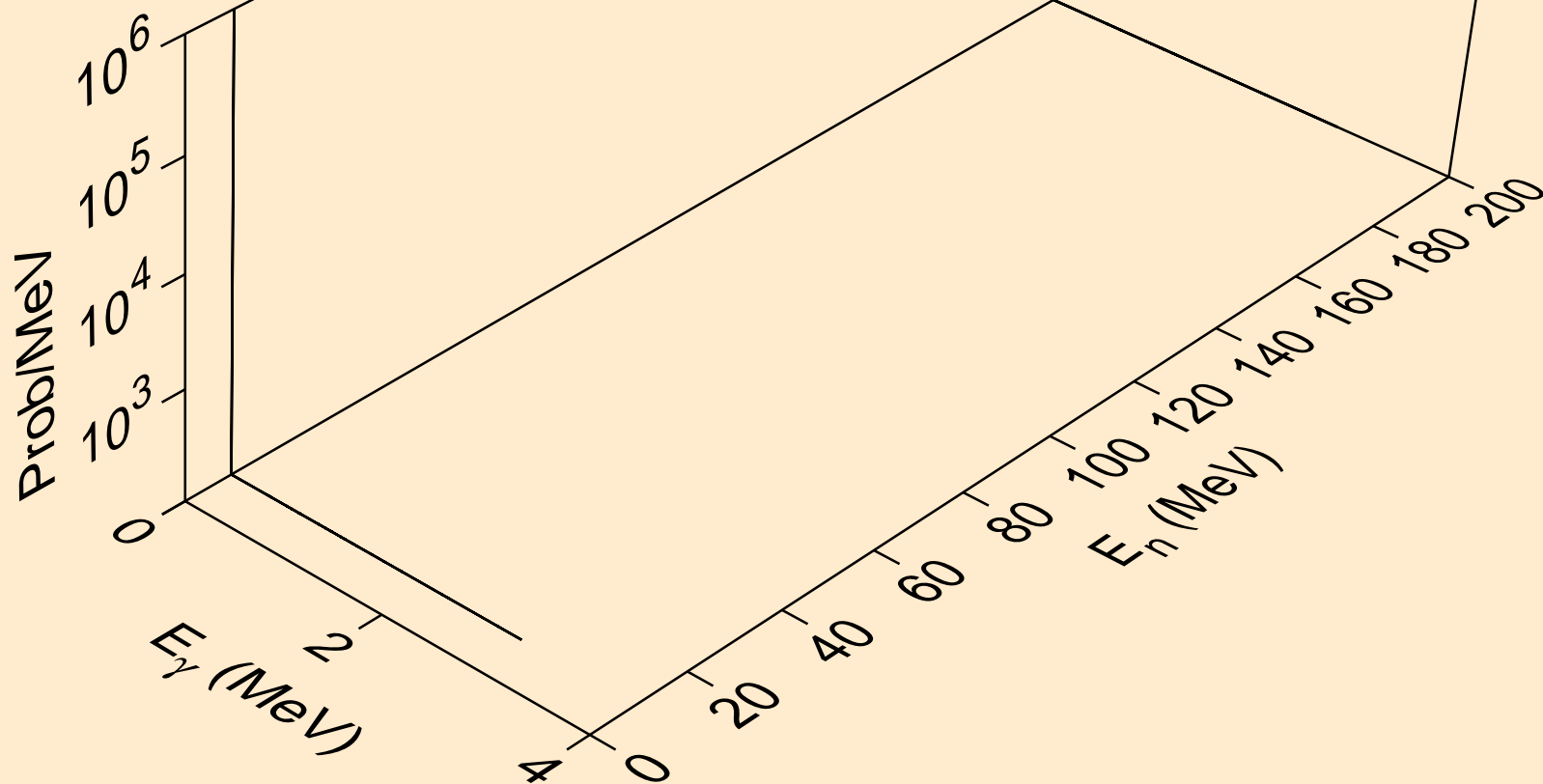

26-FE-58 FOR FENDL-3.2 FROM JEFF-3.1.1 BY NJOY2016.60+ ON
Photon emission for (n,p*2)

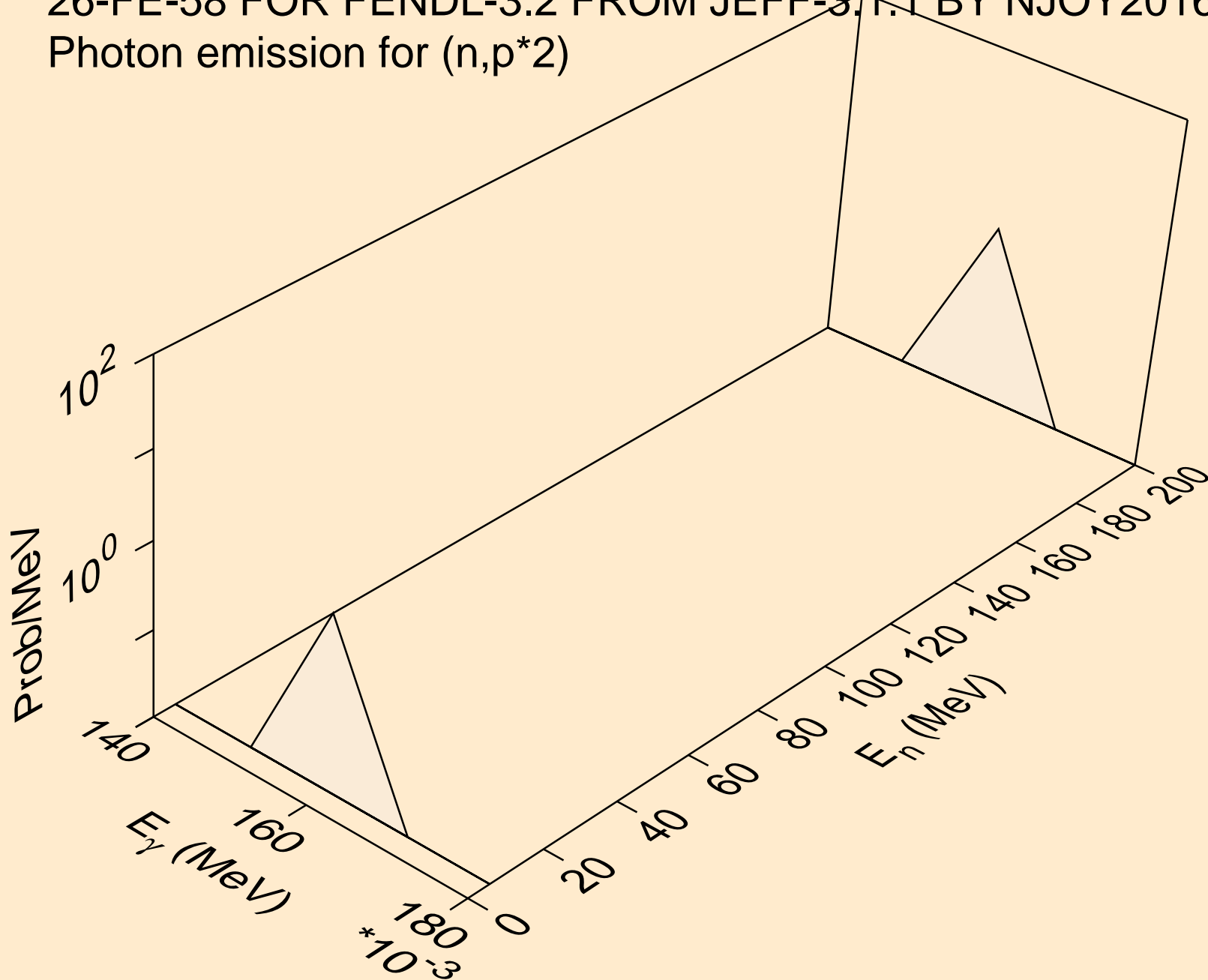

26-FE-58 FOR FENDL-3.2 FROM JEFF-3.1.1 BY NJOY2016.60+ ON
Photon emission for (n,p*3)

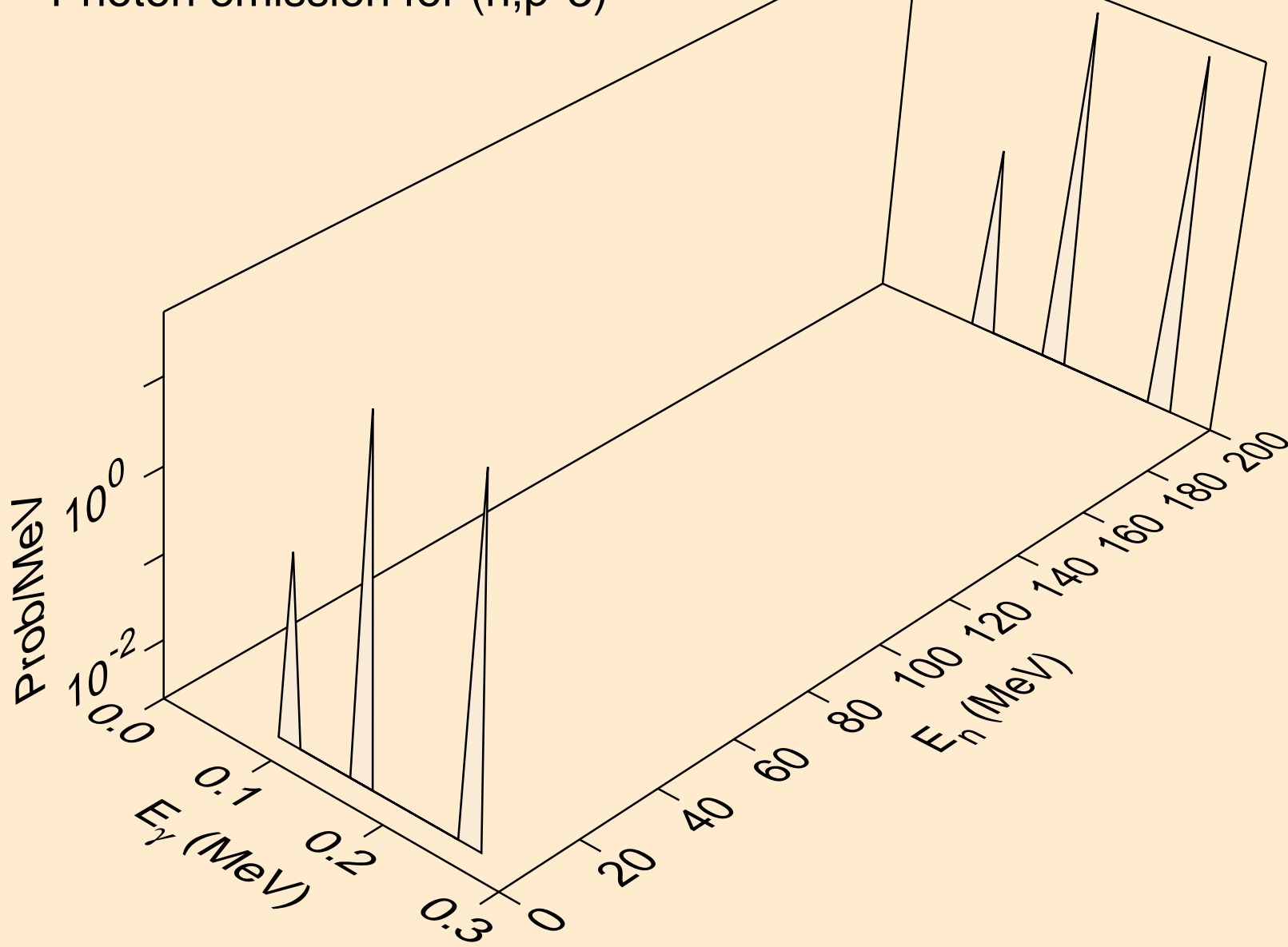

26-FE-58 FOR FENDL-3.2 FROM JEFF-3.1.1 BY NJOY2016.60+ ON
Photon emission for (n,p*4)

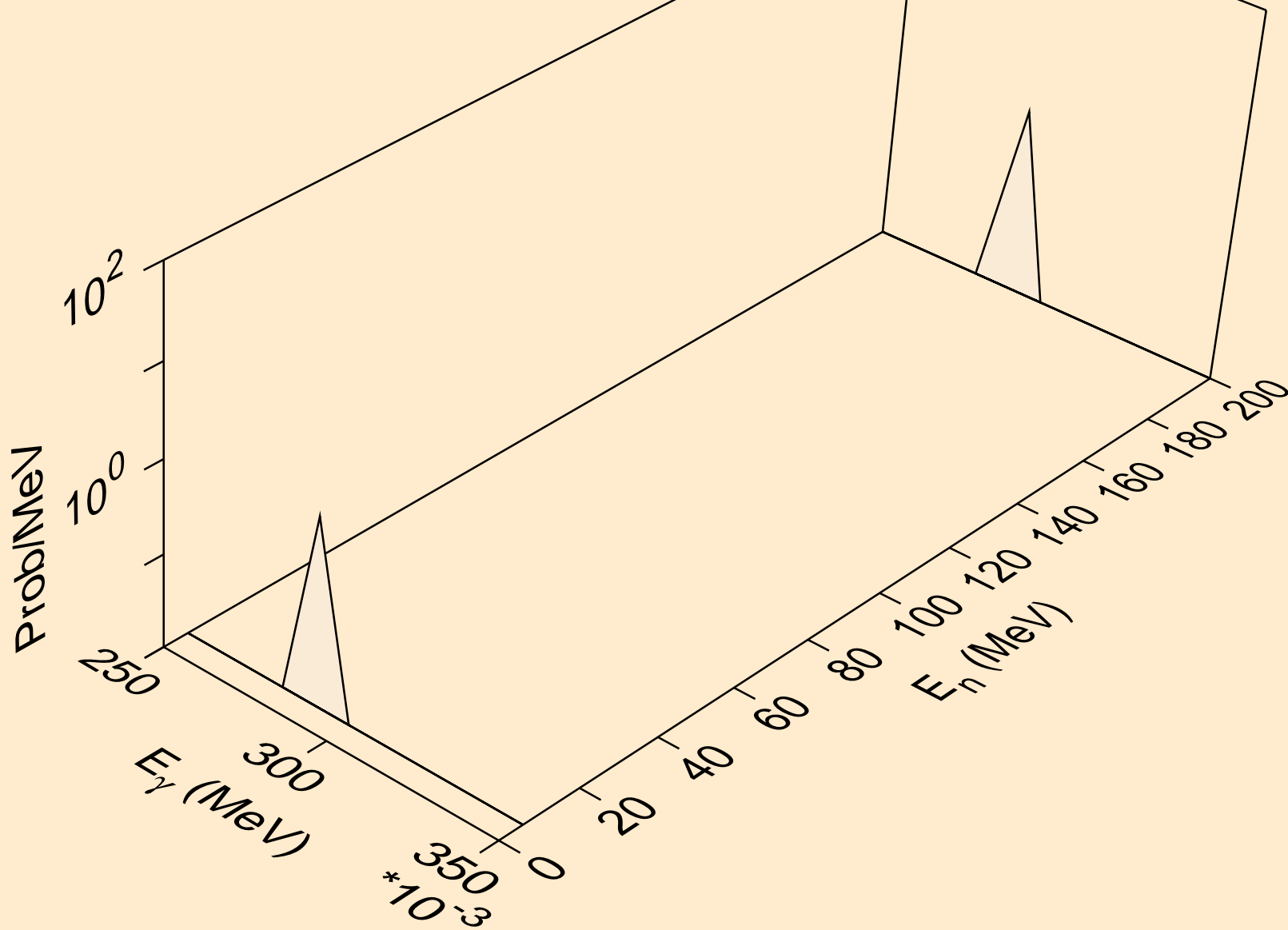

26-FE-58 FOR FENDL-3.2 FROM JEFF-3.1.1 BY NJOY2016.60+ ON
Photon emission for (n,p*5)

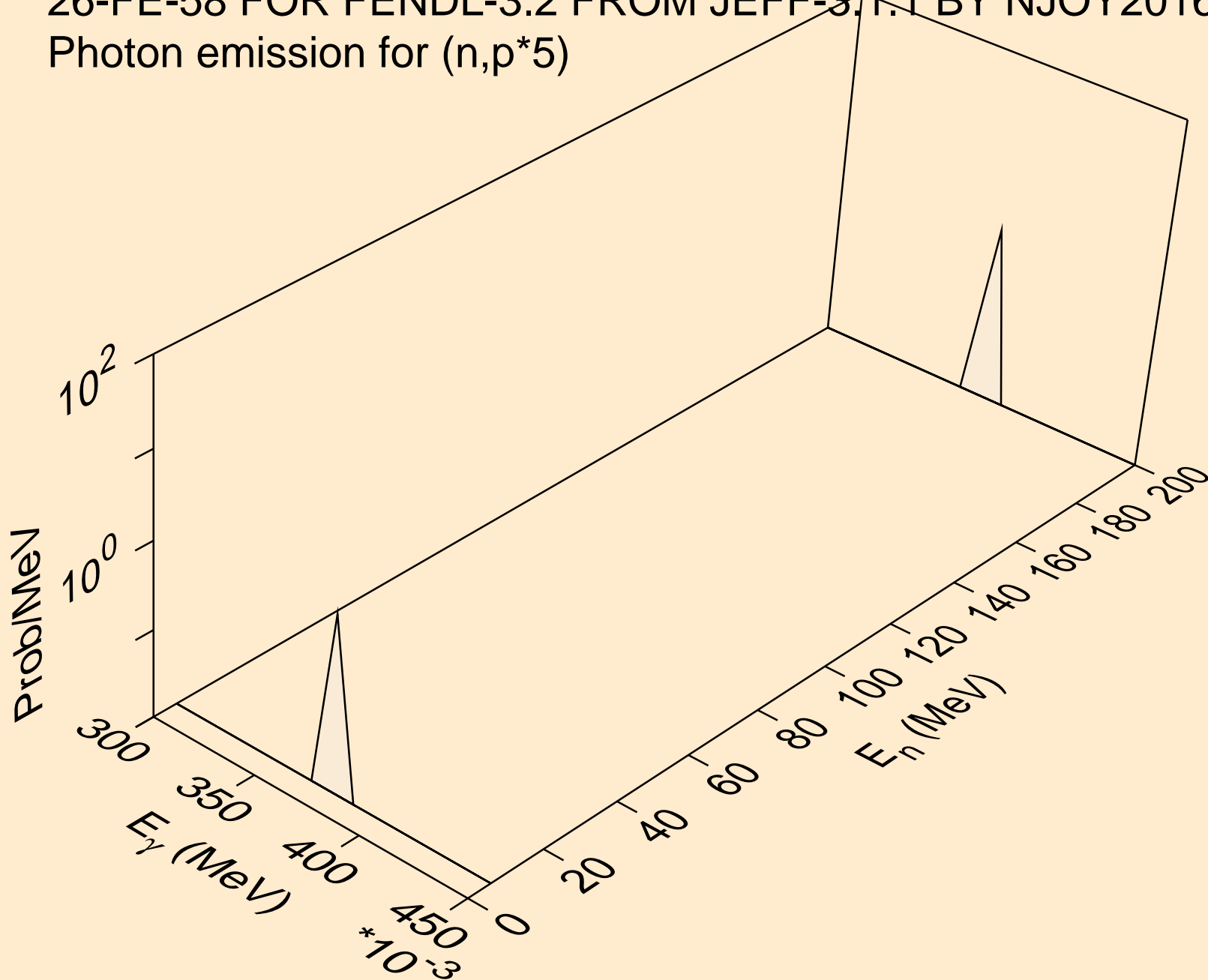

26-FE-58 FOR FENDL-3.2 FROM JEFF-3.1.1 BY NJOY2016.60+ ON
Photon emission for (n,p*6)

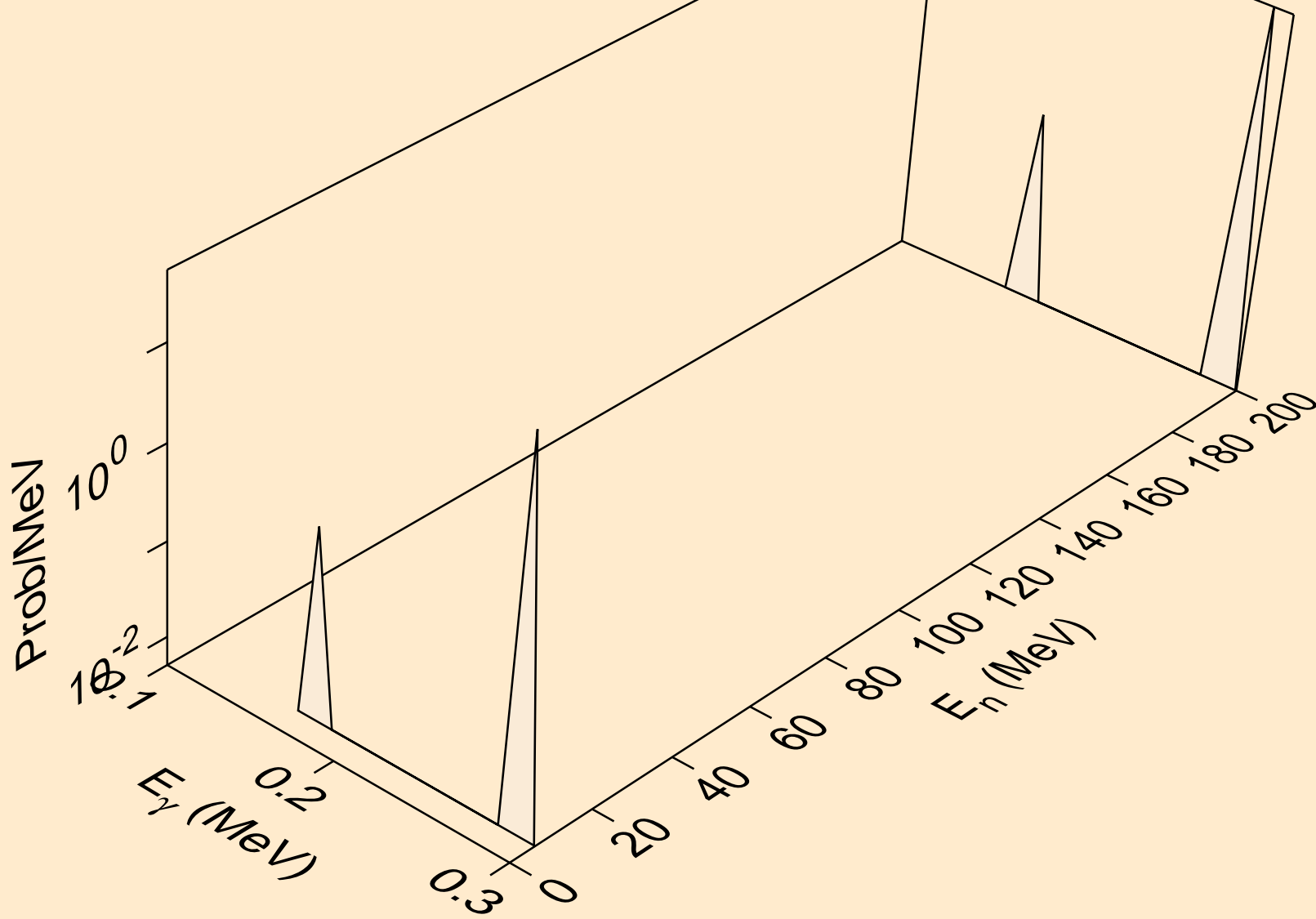

26-FE-58 FOR FENDL-3.2 FROM JEFF-3.1.1 BY NJOY2016.60+ ON
Photon emission for (n,p*7)

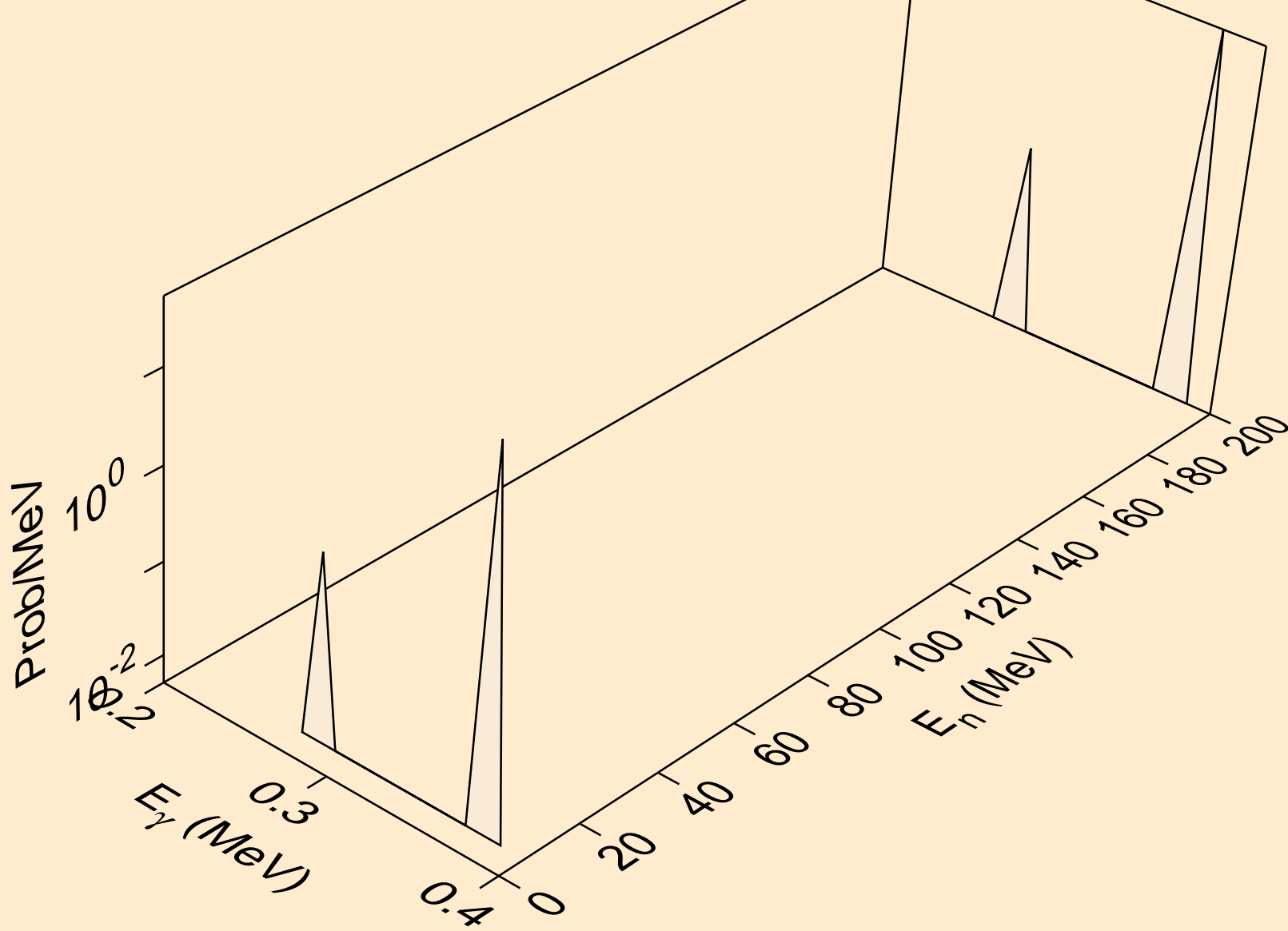

26-FE-58 FOR FENDL-3.2 FROM JEFF-3.1.1 BY NJOY2016.60+ ON
Photon emission for (n,p*8)

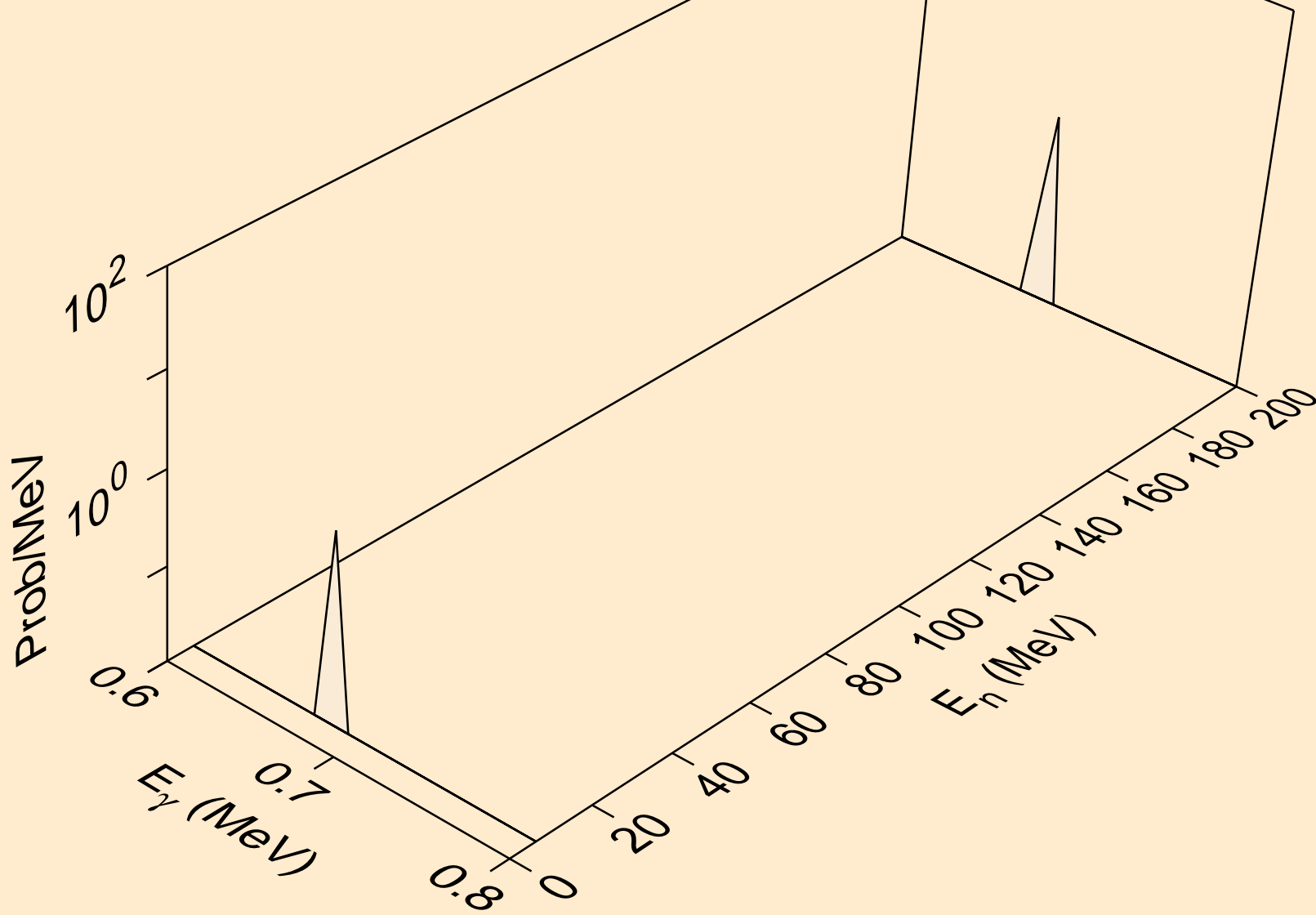

26-FE-58 FOR FENDL-3.2 FROM JEFF-3.1.1 BY NJOY2016.60+ ON
Photon emission for (n,p*9)

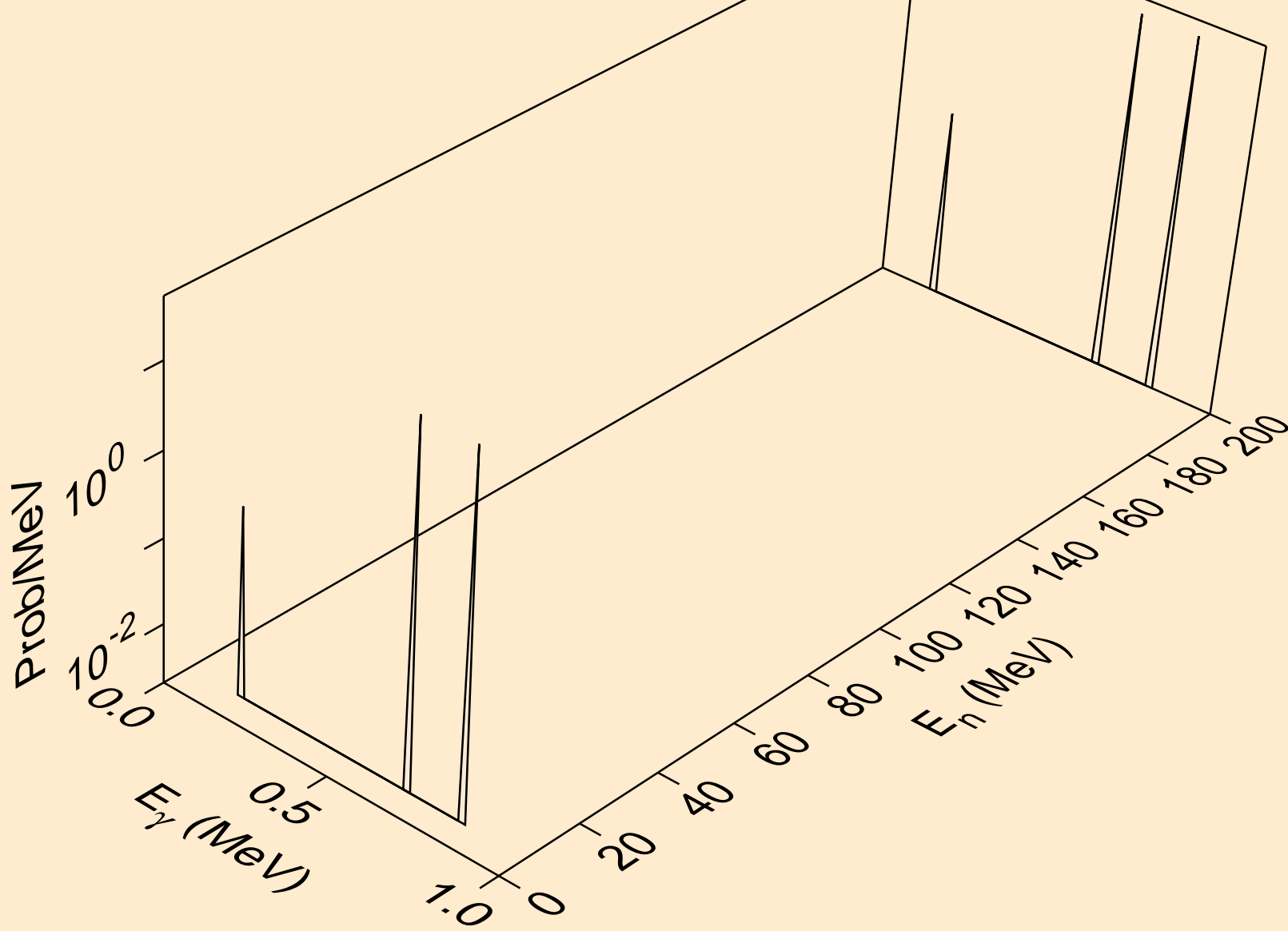

26-FE-58 FOR FENDL-3.2 FROM JEFF-3.1.1 BY NJOY2016.60+ ON
Photon emission for (n,p*10)

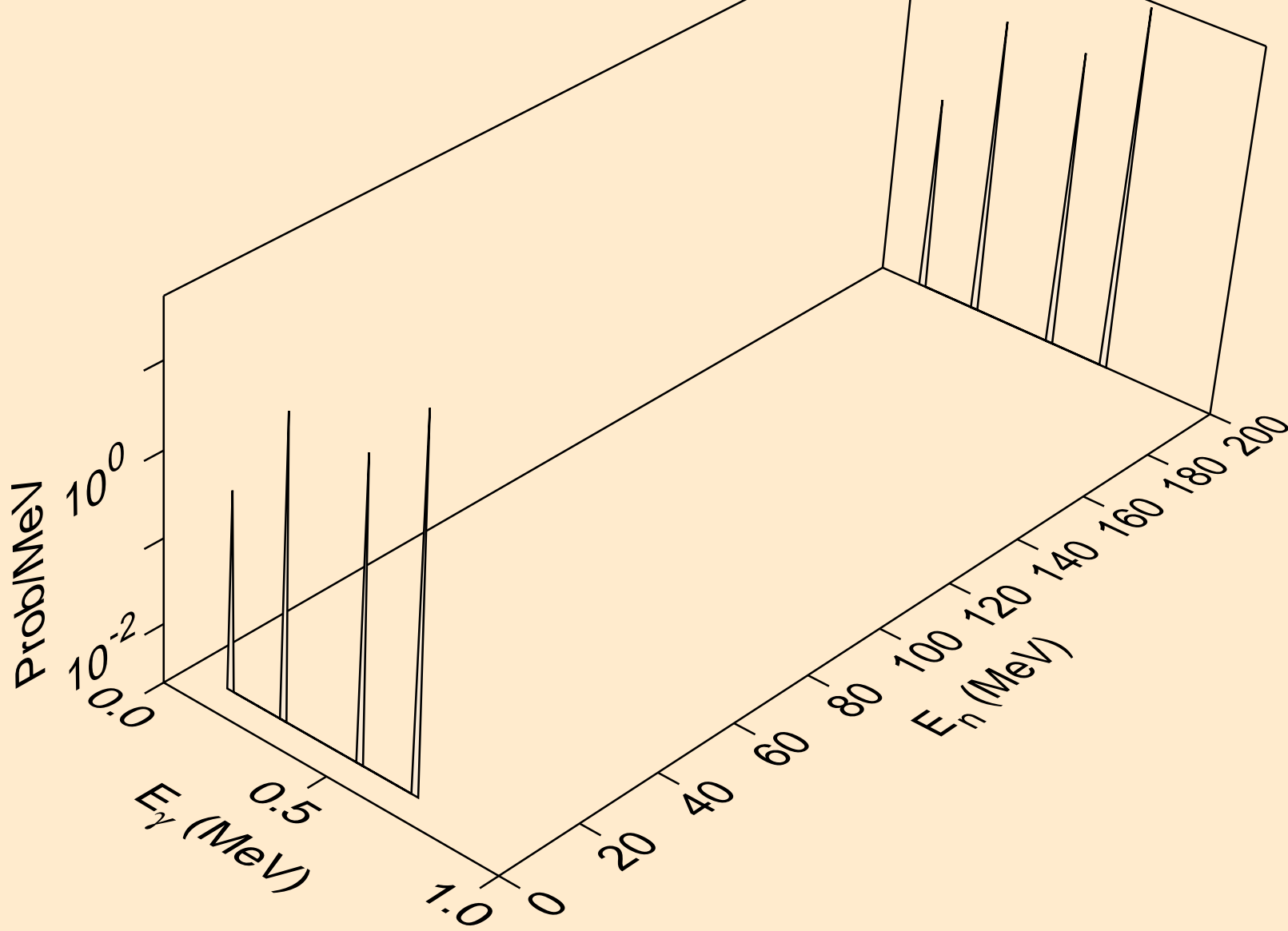

26-FE-58 FOR FENDL-3.2 FROM JEFF-3.1.1 BY NJOY2016.60+ ON
Photon emission for (n,p*c)

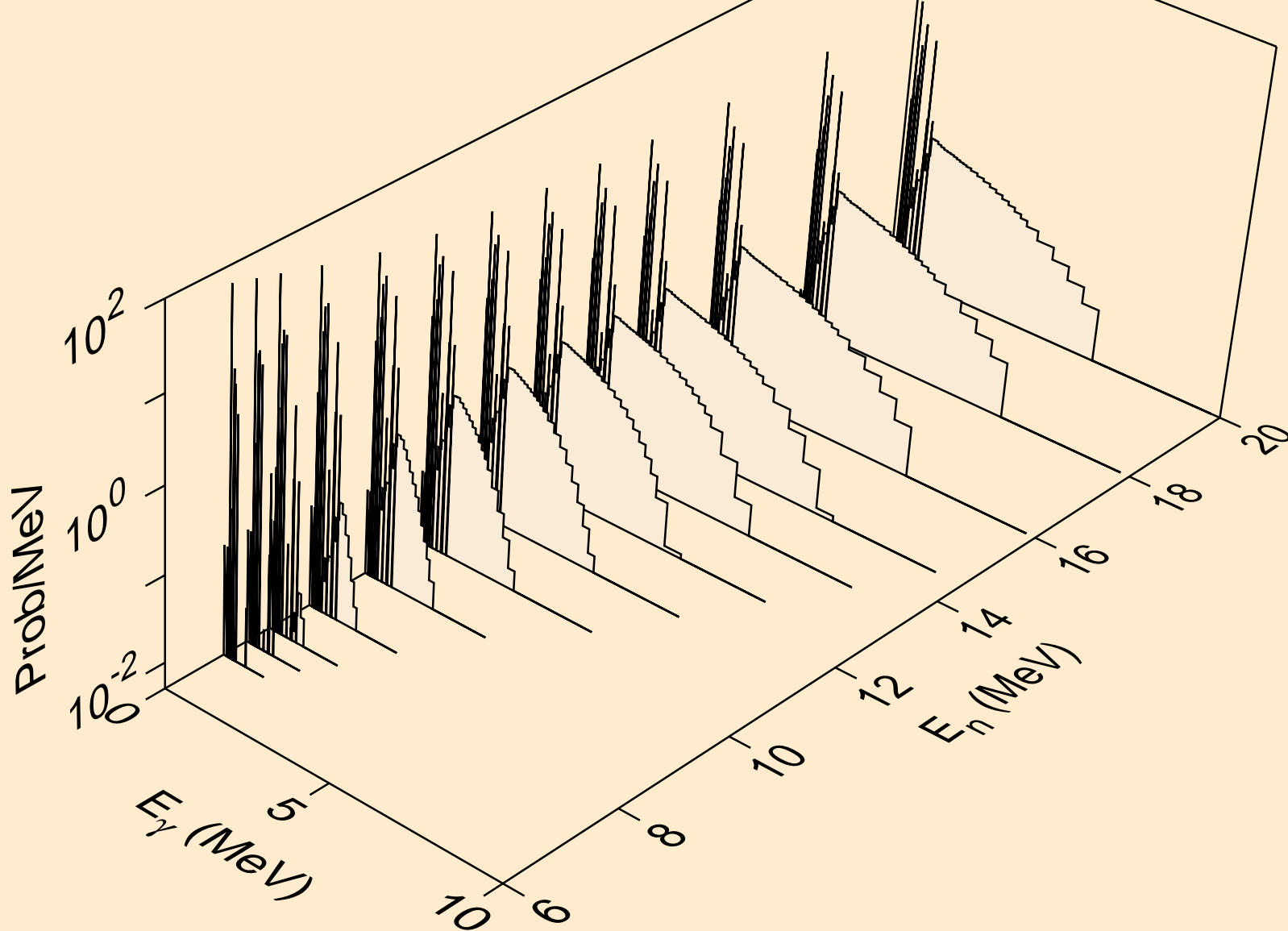

26-FE-58 FOR FENDL-3.2 FROM JEFF-3.1.1 BY NJOY2016.60+ ON
Photon emission for (n,d*1)

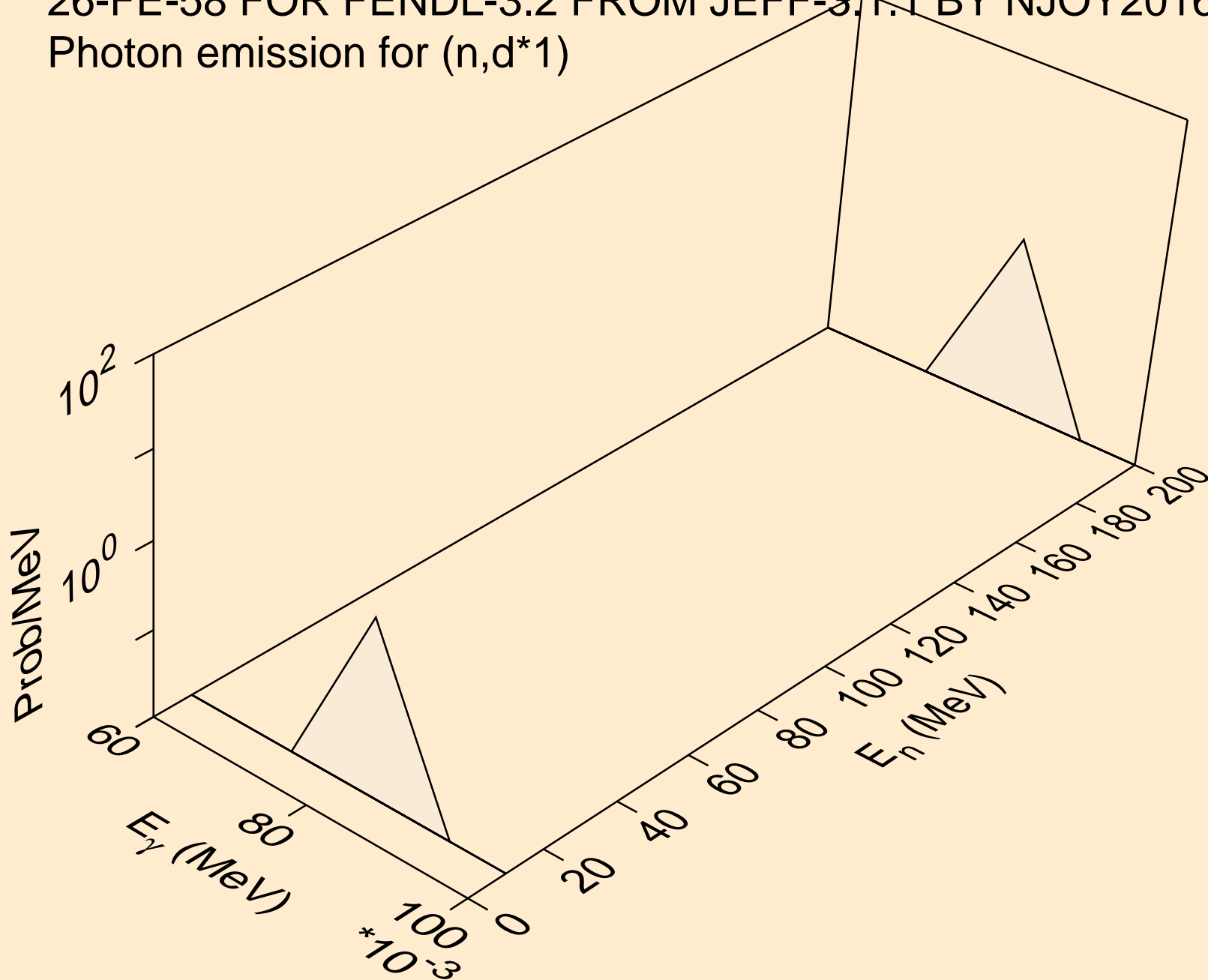

26-FE-58 FOR FENDL-3.2 FROM JEFF-3.1.1 BY NJOY2016.60+ ON
Photon emission for (n,d*2)

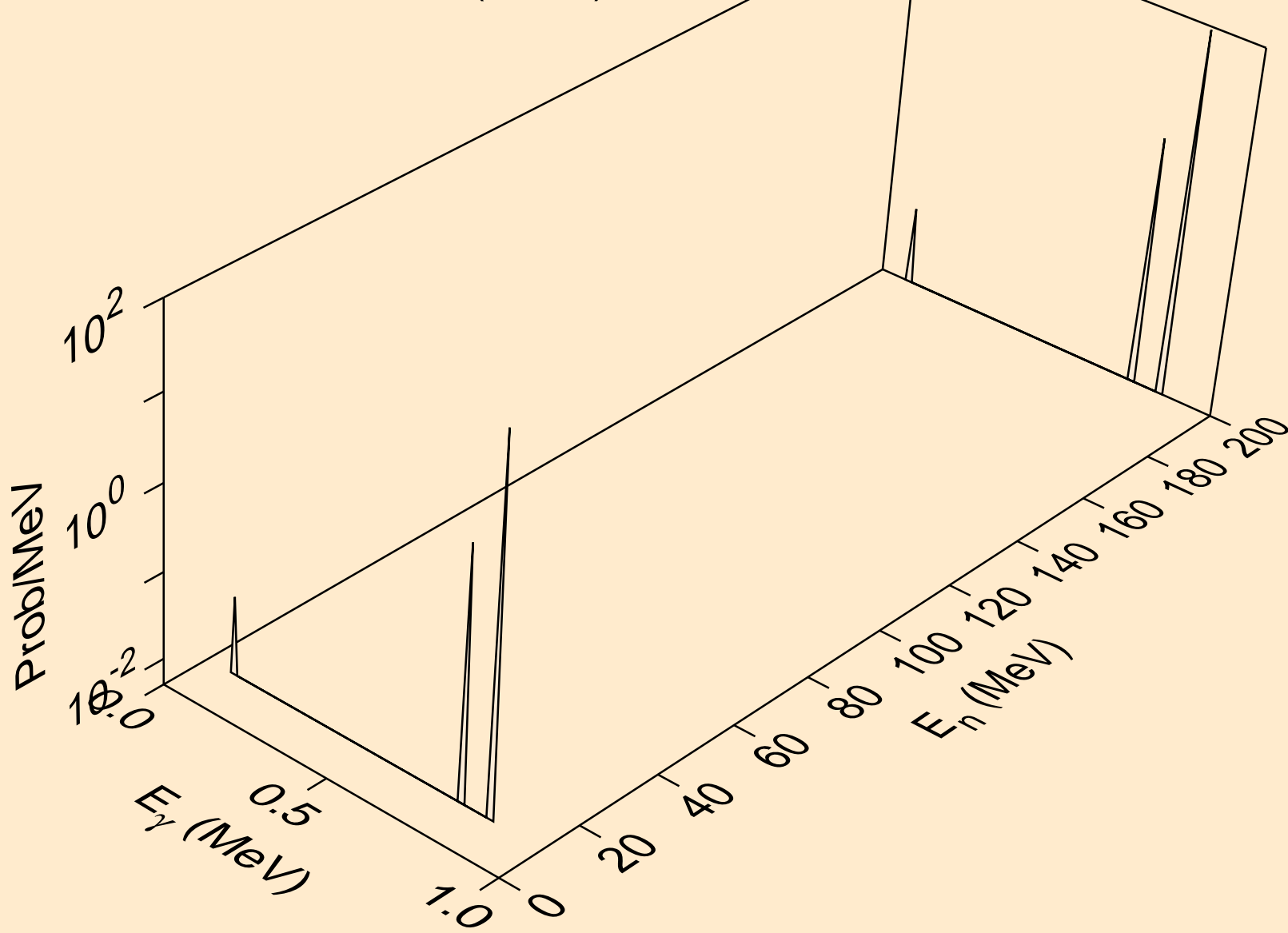

26-FE-58 FOR FENDL-3.2 FROM JEFF-3.1.1 BY NJOY2016.60+ ON
Photon emission for (n,d*3)

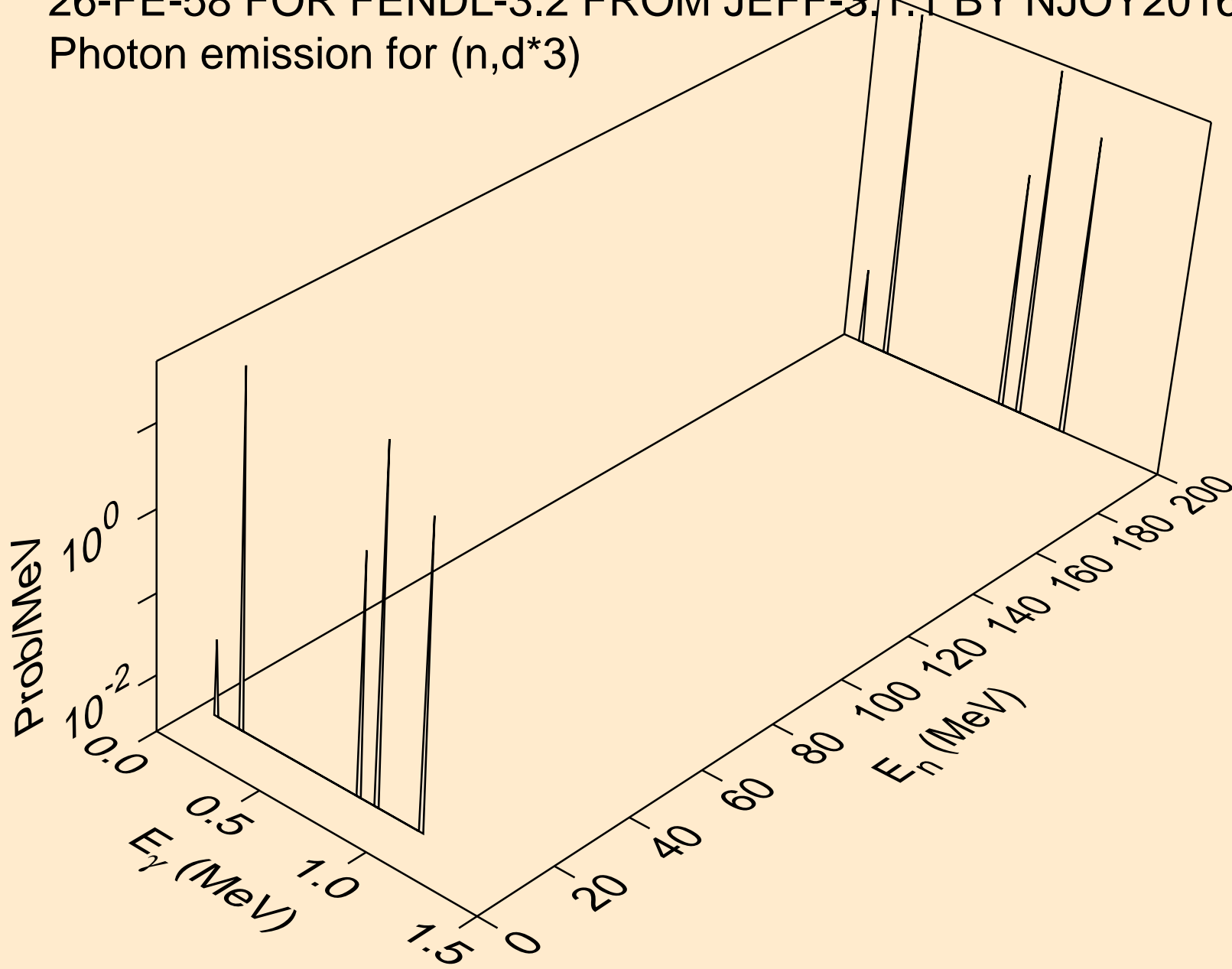

26-FE-58 FOR FENDL-3.2 FROM JEFF-3.1.1 BY NJOY2016.60+ ON
Photon emission for (n,d*4)

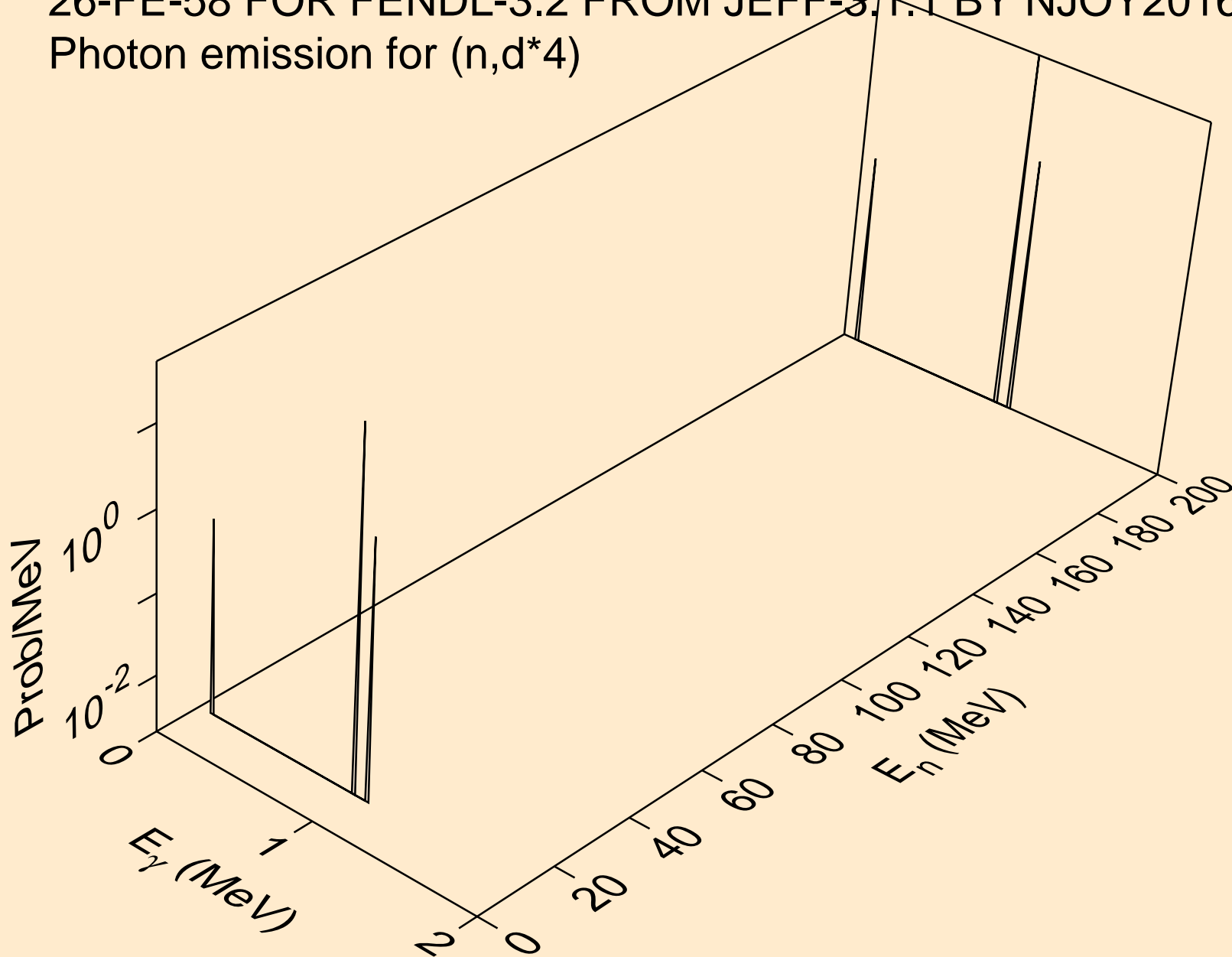

26-FE-58 FOR FENDL-3.2 FROM JEFF-3.1.1 BY NJOY2016.60+ ON
Photon emission for (n,d*5)

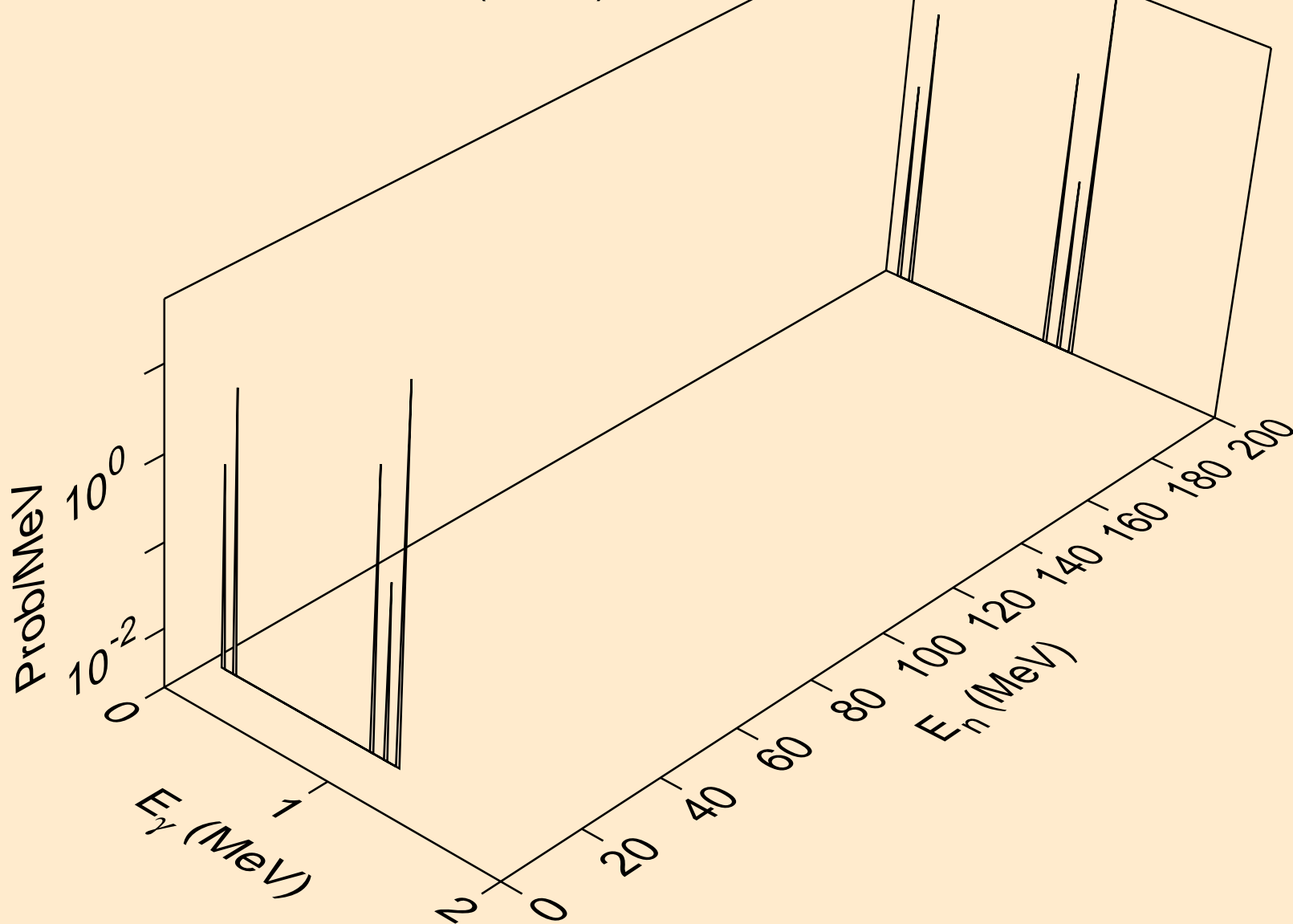

26-FE-58 FOR FENDL-3.2 FROM JEFF-3.1.1 BY NJOY2016.60+ ON
Photon emission for (n,d*c)

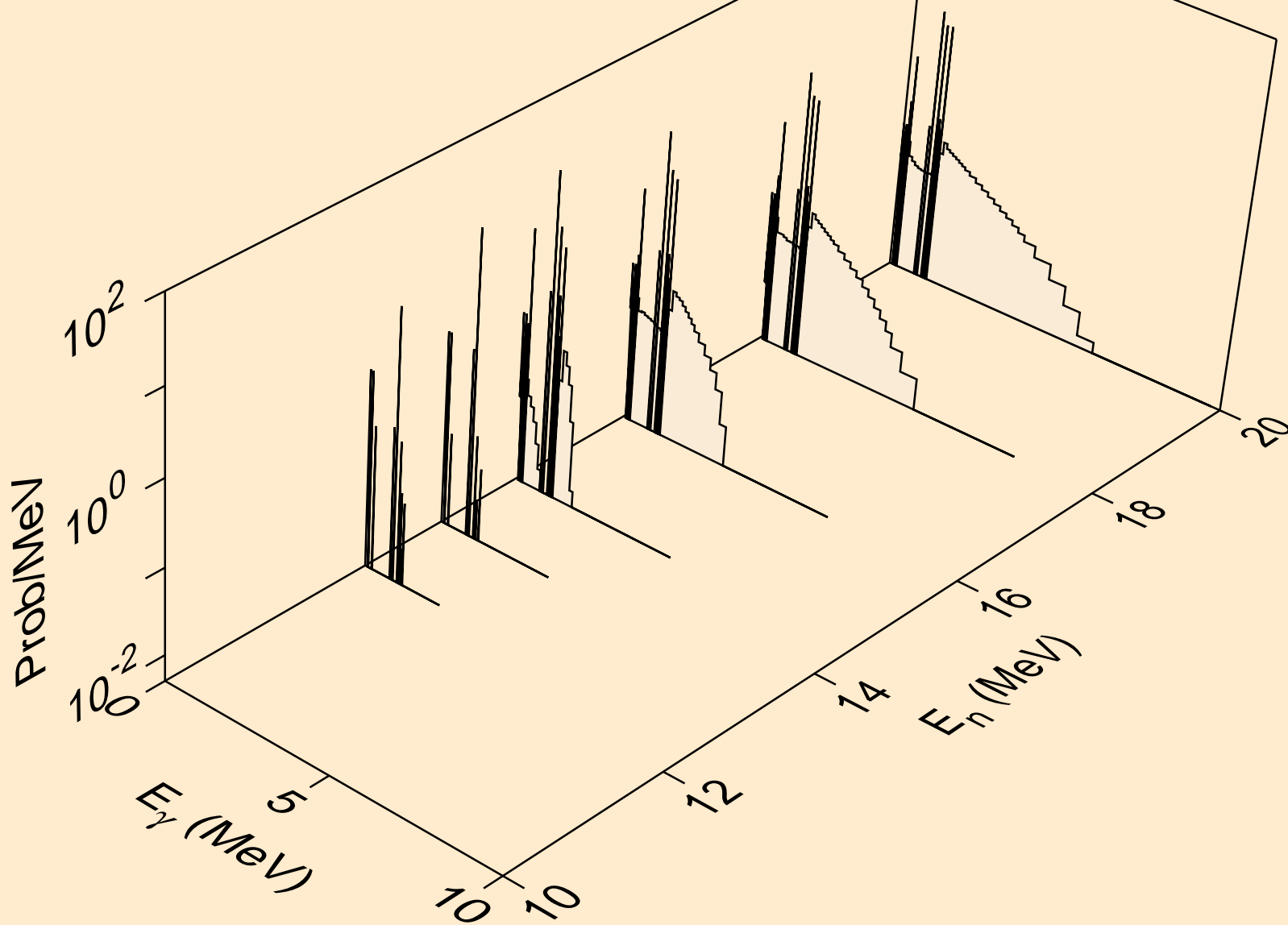

26-FE-58 FOR FENDL-3.2 FROM JEFF-3.1.1 BY NJOY2016.60+ ON
Photon emission for (n,t*1)

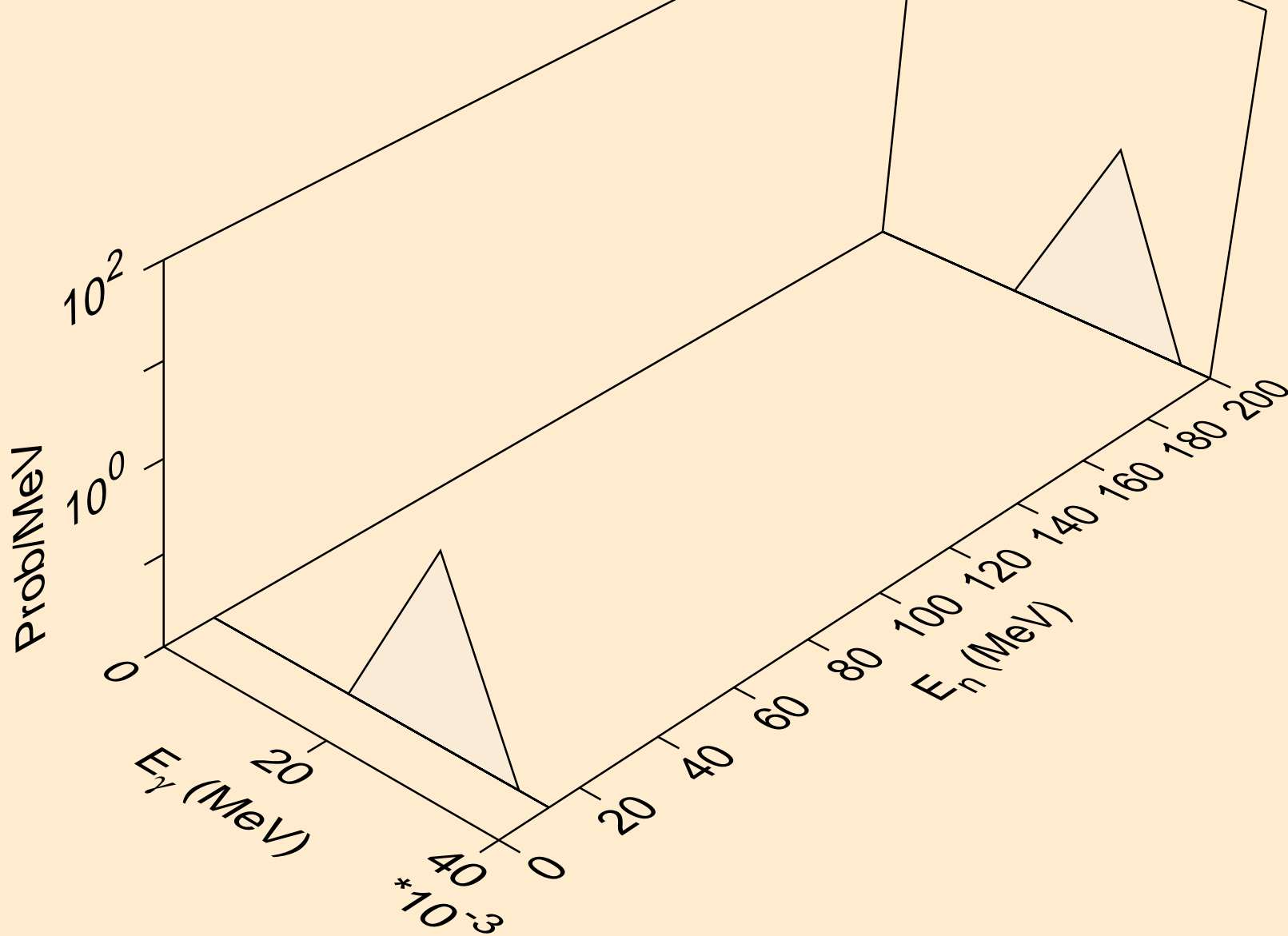

26-FE-58 FOR FENDL-3.2 FROM JEFF-3.1.1 BY NJOY2016.60+ ON
Photon emission for (n,t*2)

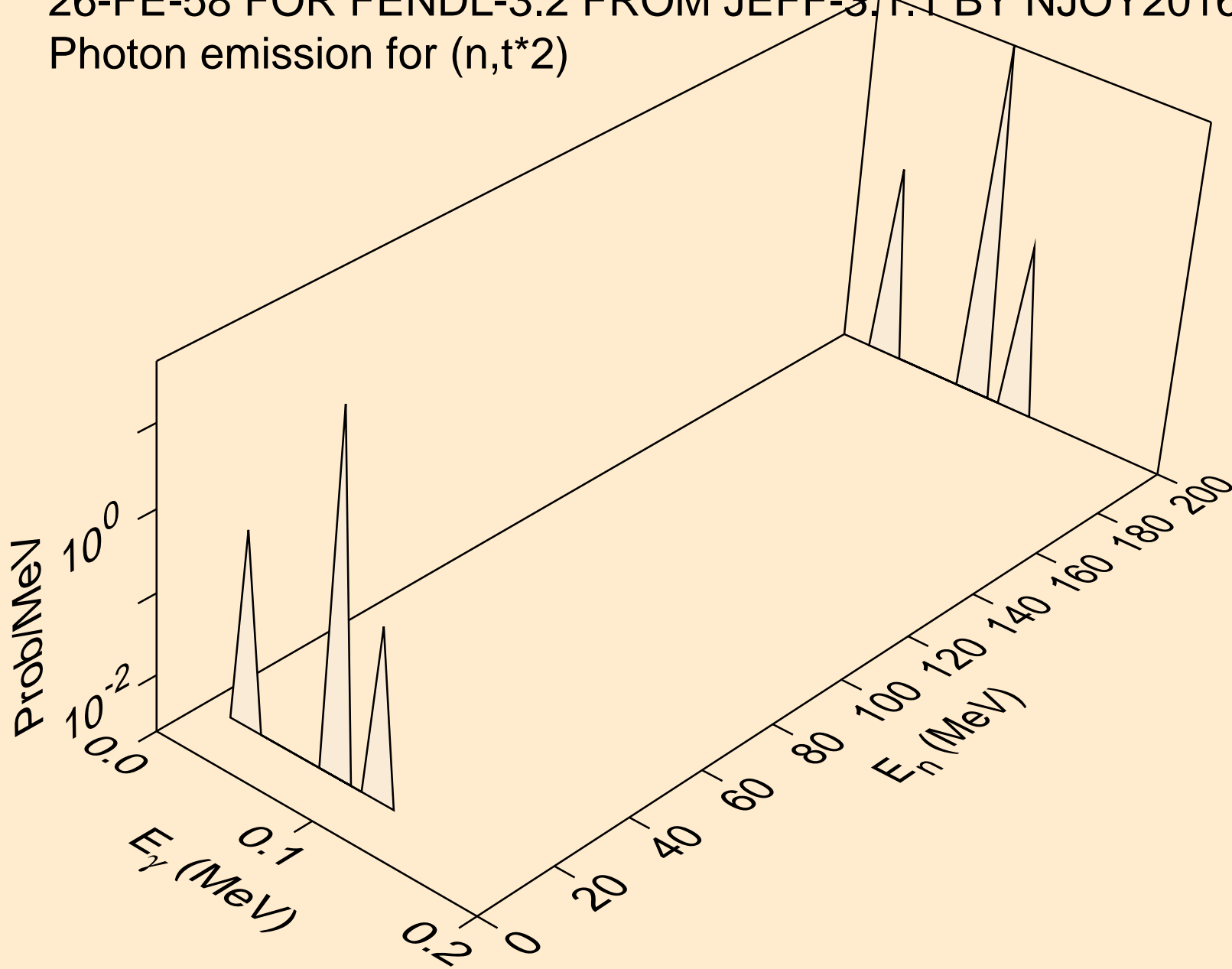

26-FE-58 FOR FENDL-3.2 FROM JEFF-3.1.1 BY NJOY2016.60+ ON
Photon emission for (n,t*3)

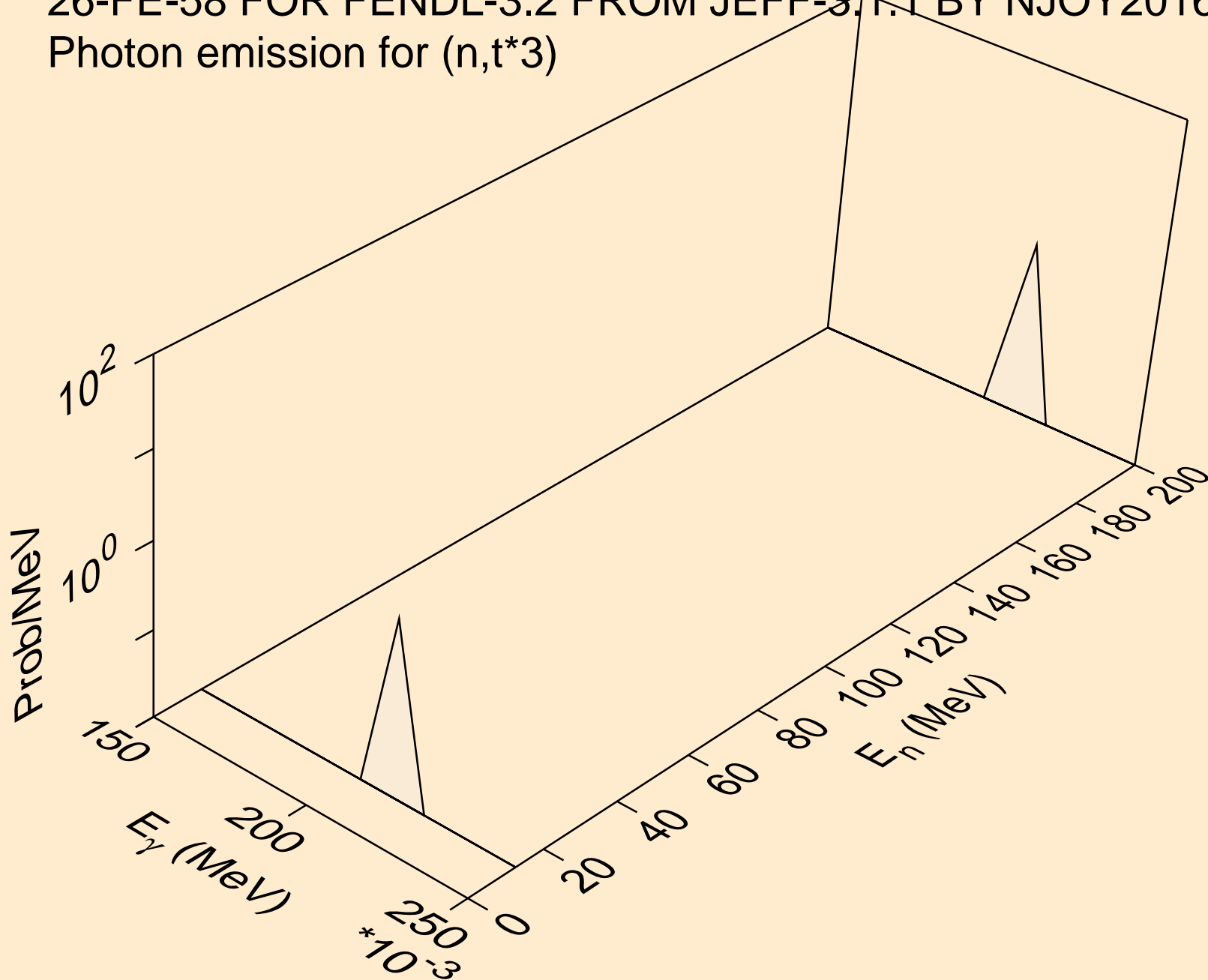

26-FE-58 FOR FENDL-3.2 FROM JEFF-3.1.1 BY NJOY2016.60+ ON
Photon emission for (n,t*4)

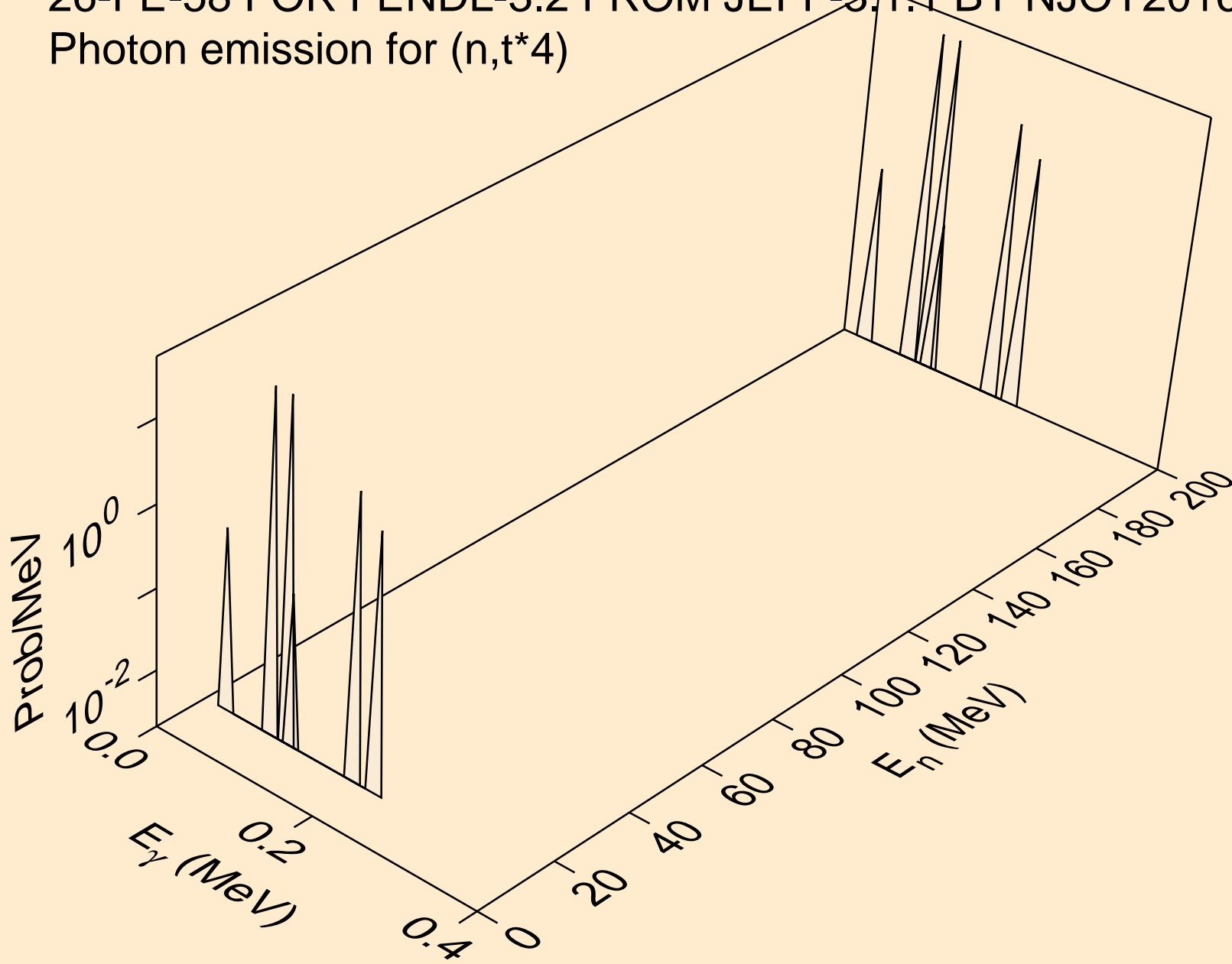

26-FE-58 FOR FENDL-3.2 FROM JEFF-3.1.1 BY NJOY2016.60+ ON
Photon emission for (n,t*5)

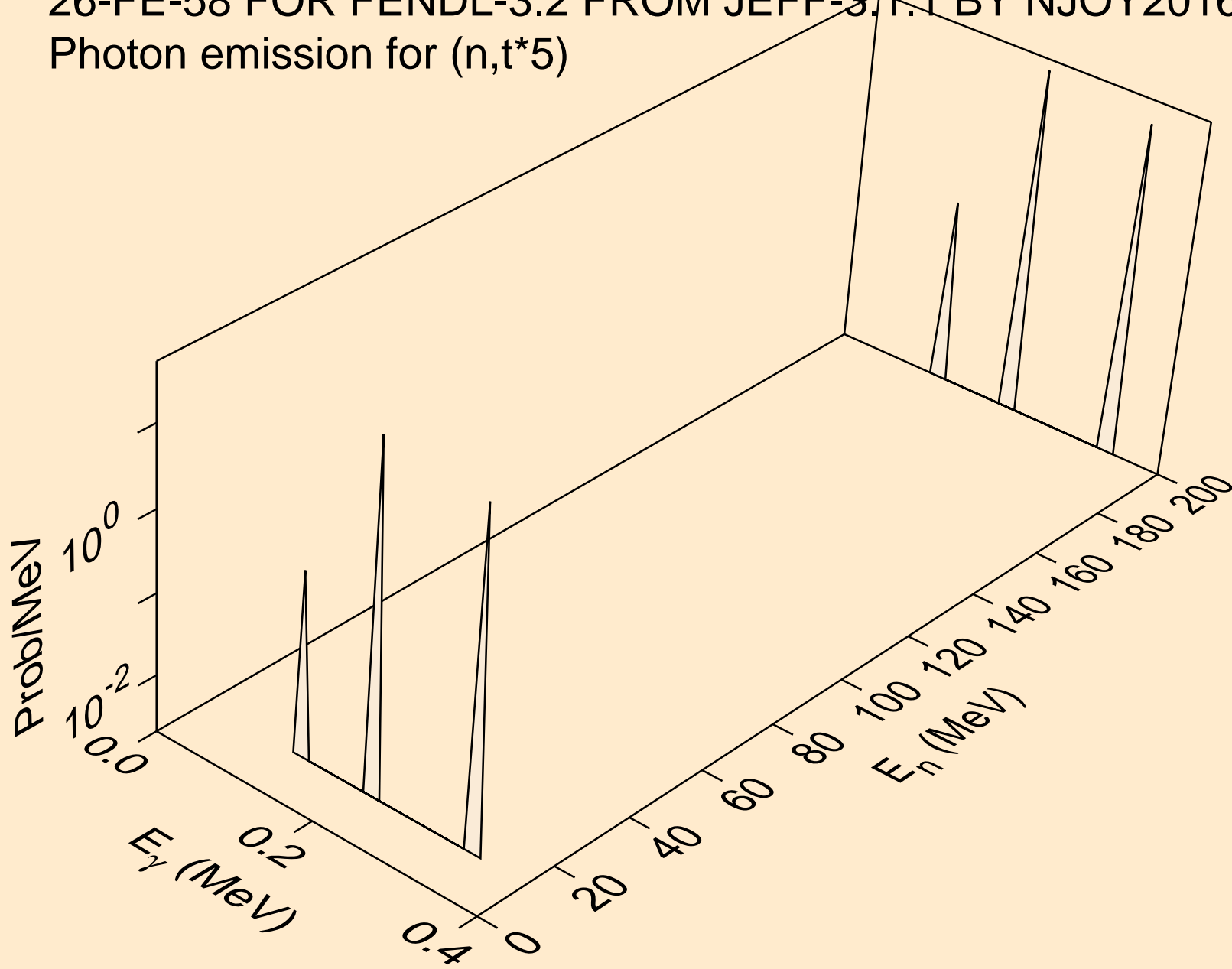

26-FE-58 FOR FENDL-3.2 FROM JEFF-3.1.1 BY NJOY2016.60+ ON
Photon emission for (n,t*c)

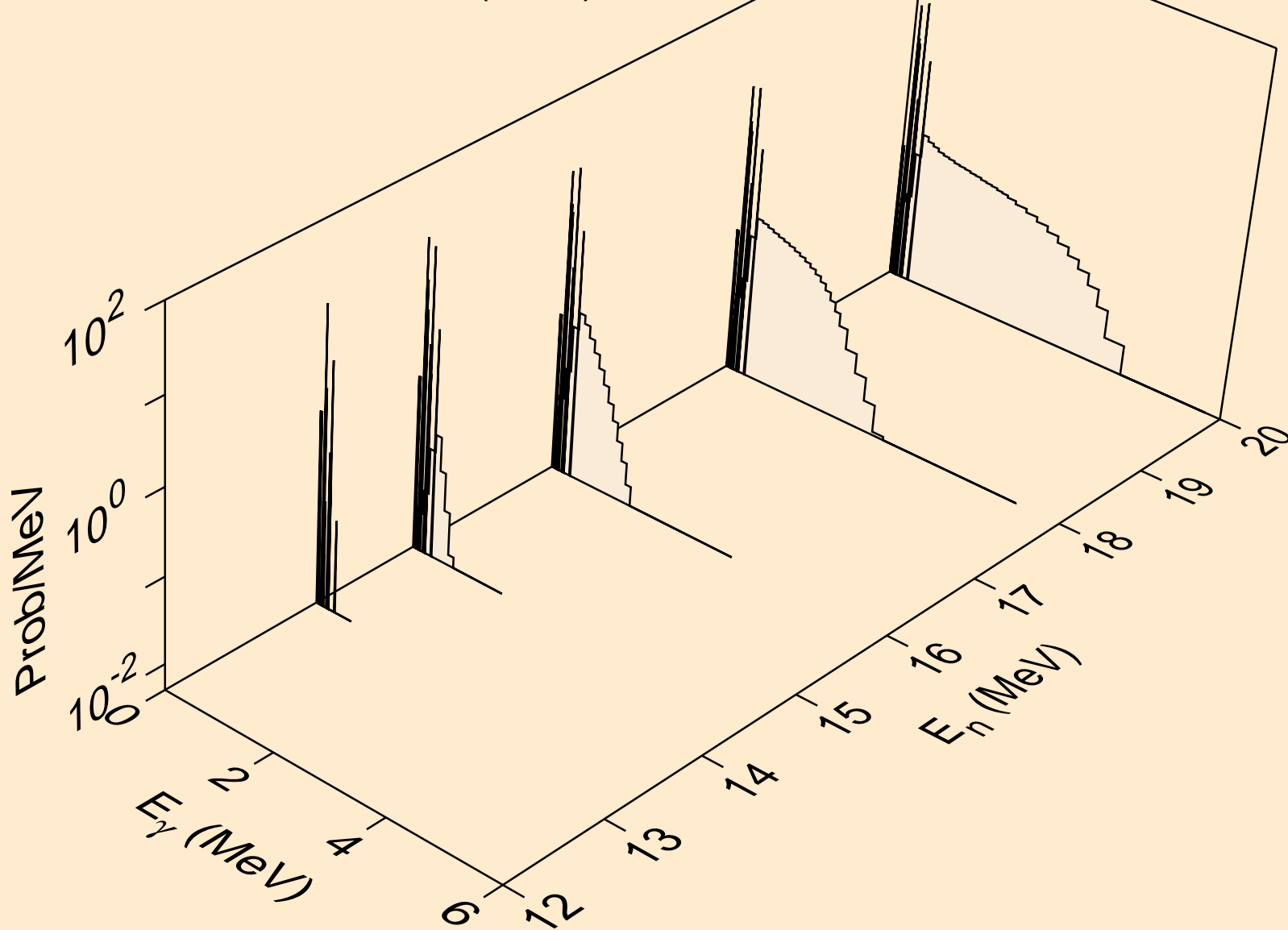

26-FE-58 FOR FENDL-3.2 FROM JEFF-3.1.1 BY NJOY2016.60+ ON
Photon emission for (n,he3*1)

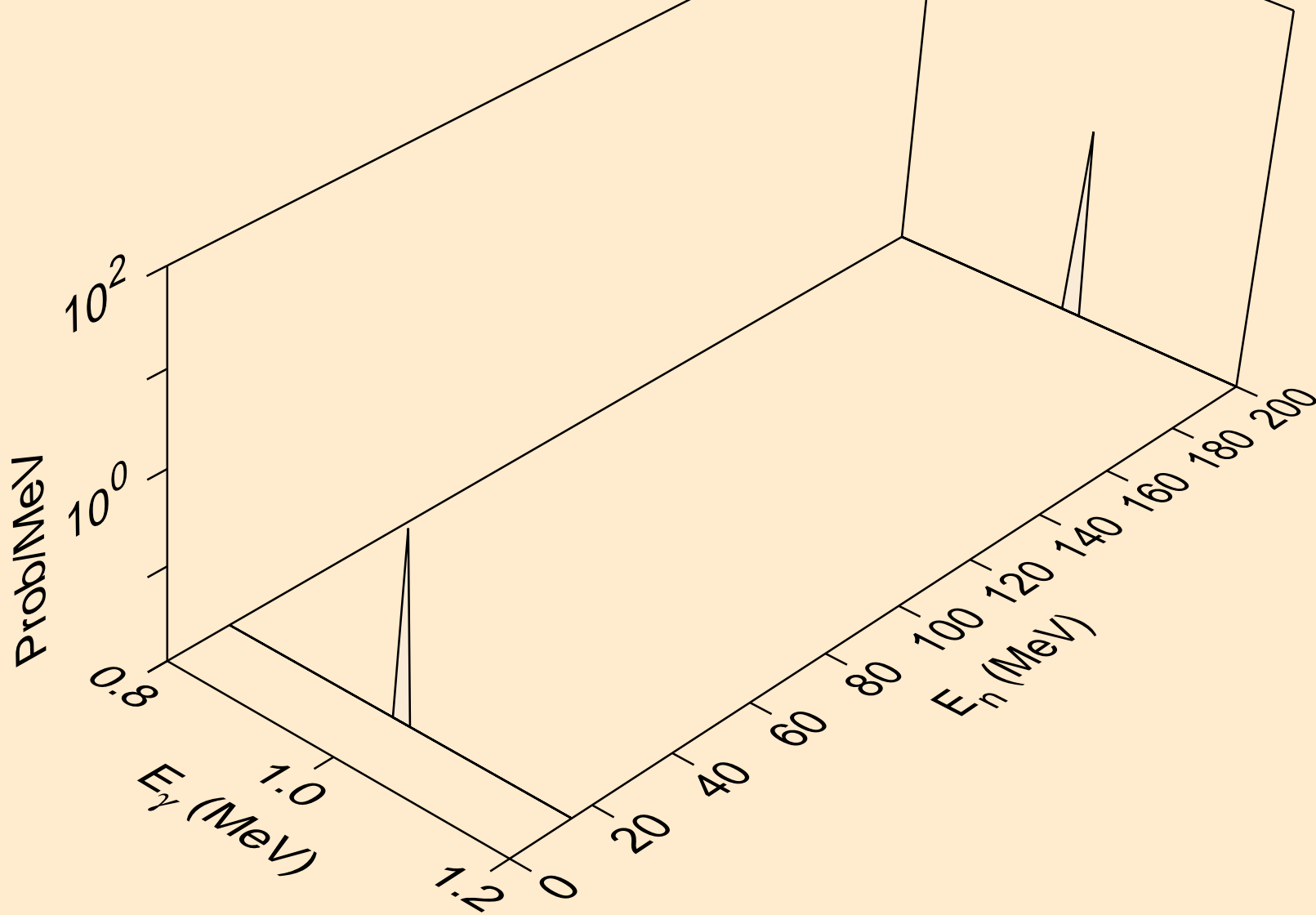

26-FE-58 FOR FENDL-3.2 FROM JEFF-3.1.1 BY NJOY2016.60+ ON
Photon emission for (n,he3*2)

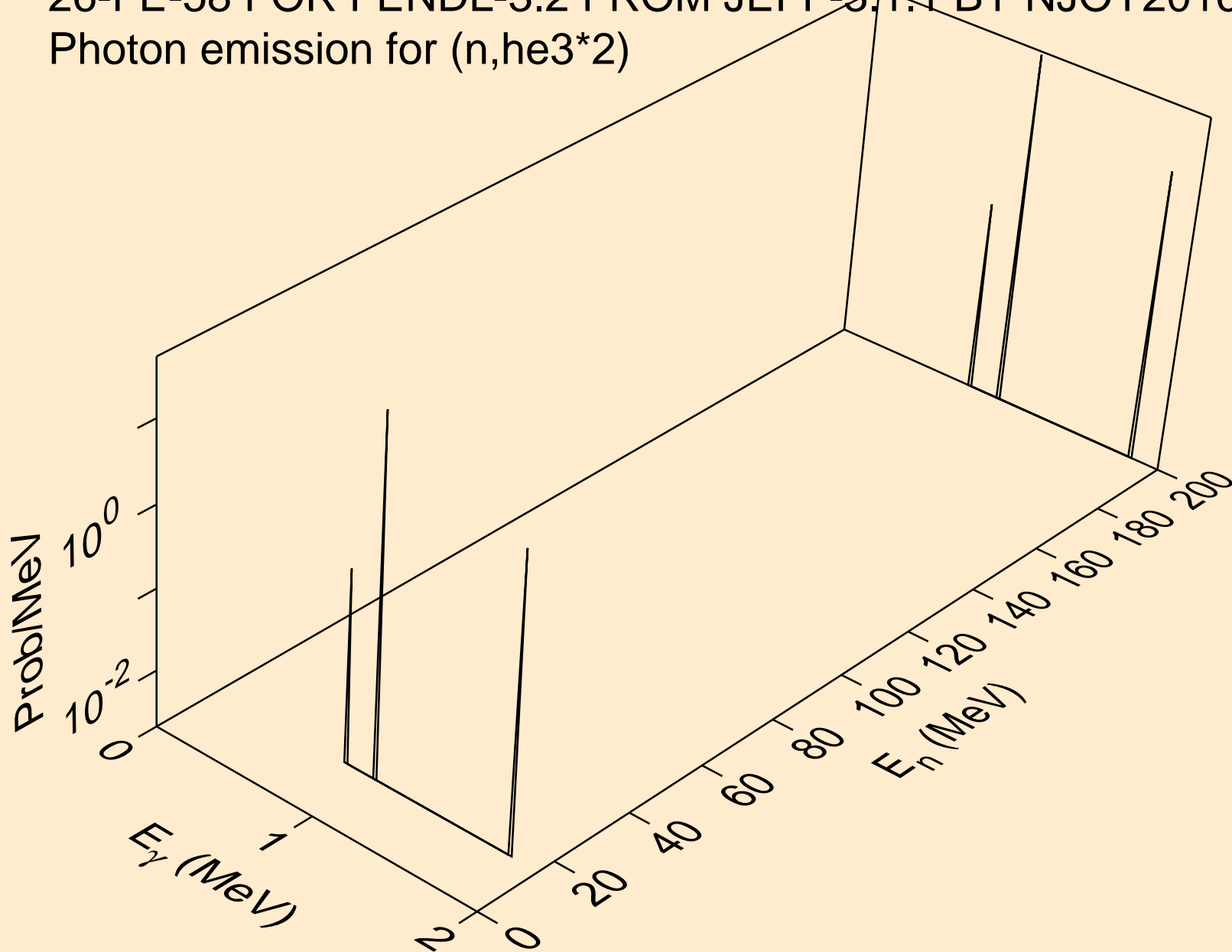

26-FE-58 FOR FENDL-3.2 FROM JEFF-3.1.1 BY NJOY2016.60+ ON
Photon emission for (n,a*1)

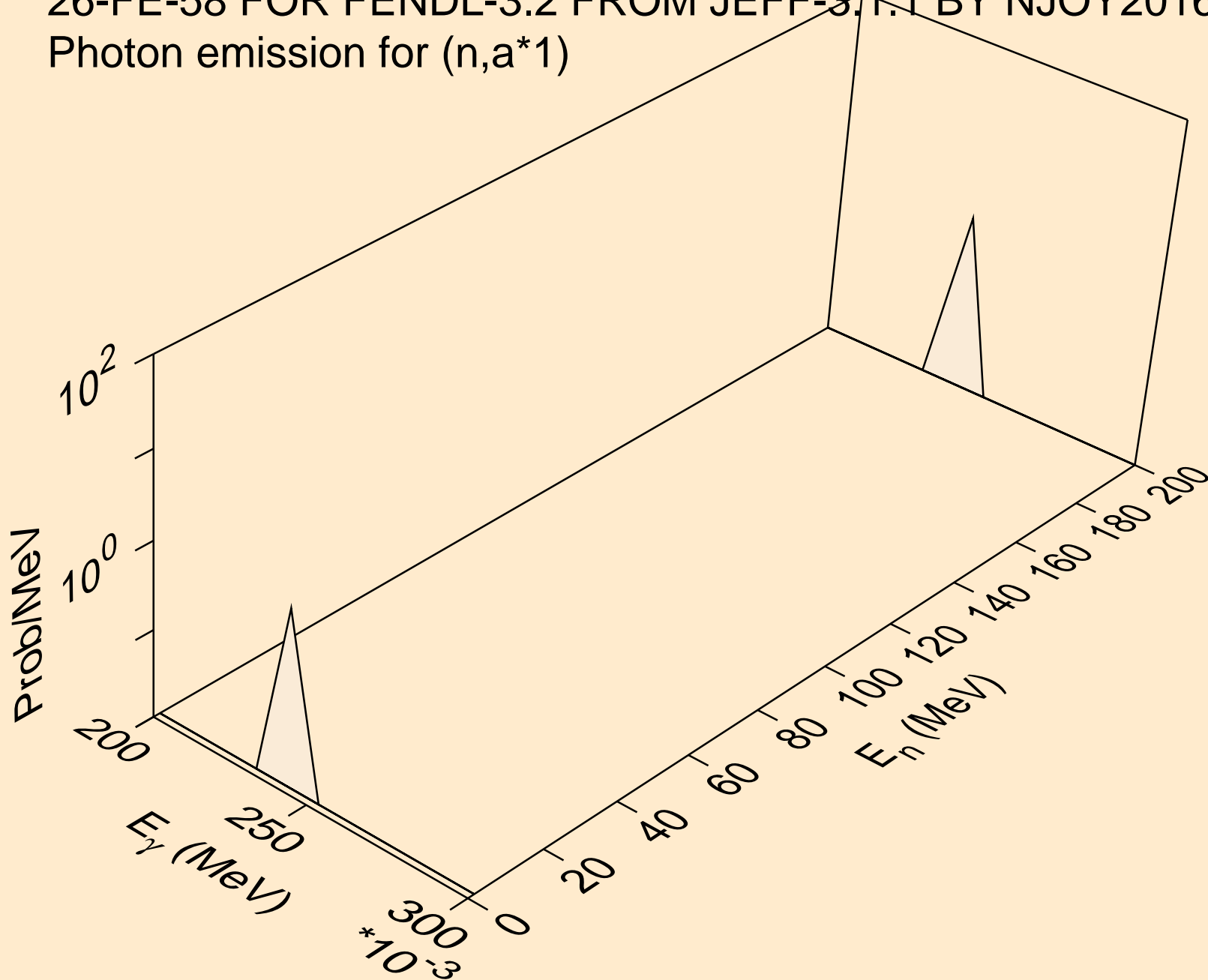

26-FE-58 FOR FENDL-3.2 FROM JEFF-3.1.1 BY NJOY2016.60+ ON
Photon emission for (n,a*2)

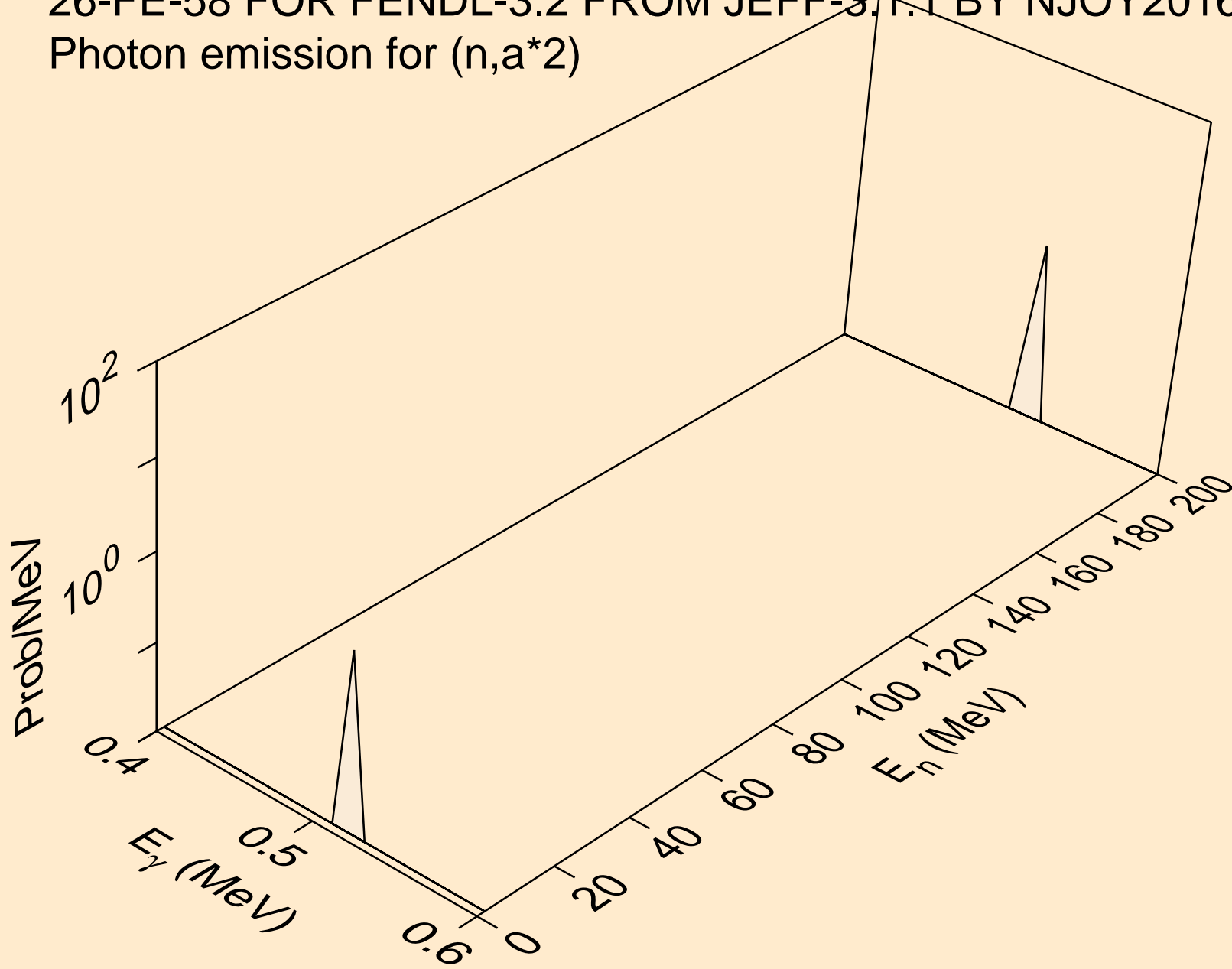

26-FE-58 FOR FENDL-3.2 FROM JEFF-3.1.1 BY NJOY2016.60+ ON
Photon emission for (n,a*3)

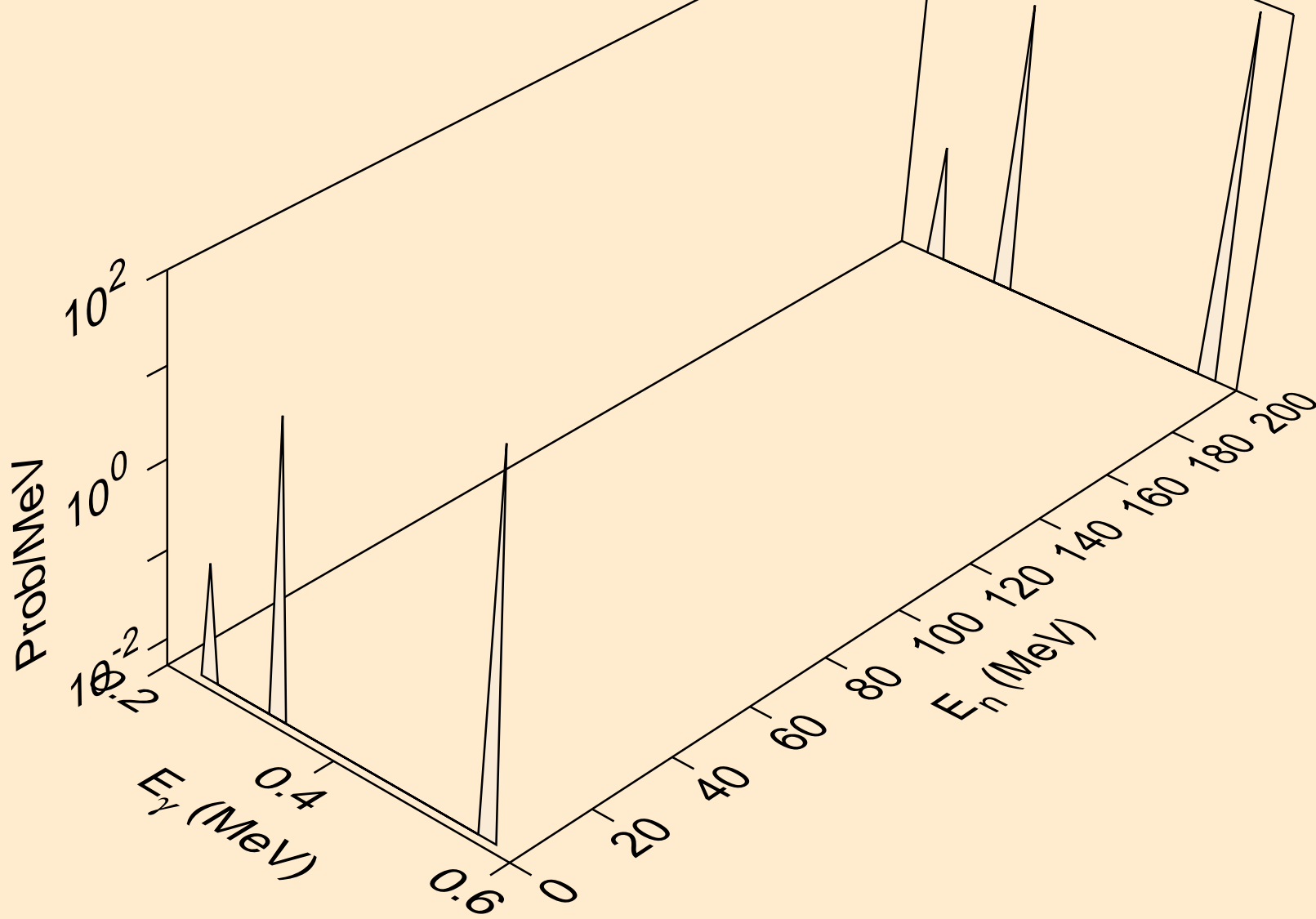

26-FE-58 FOR FENDL-3.2 FROM JEFF-3.1.1 BY NJOY2016.60+ ON
Photon emission for (n,a*4)

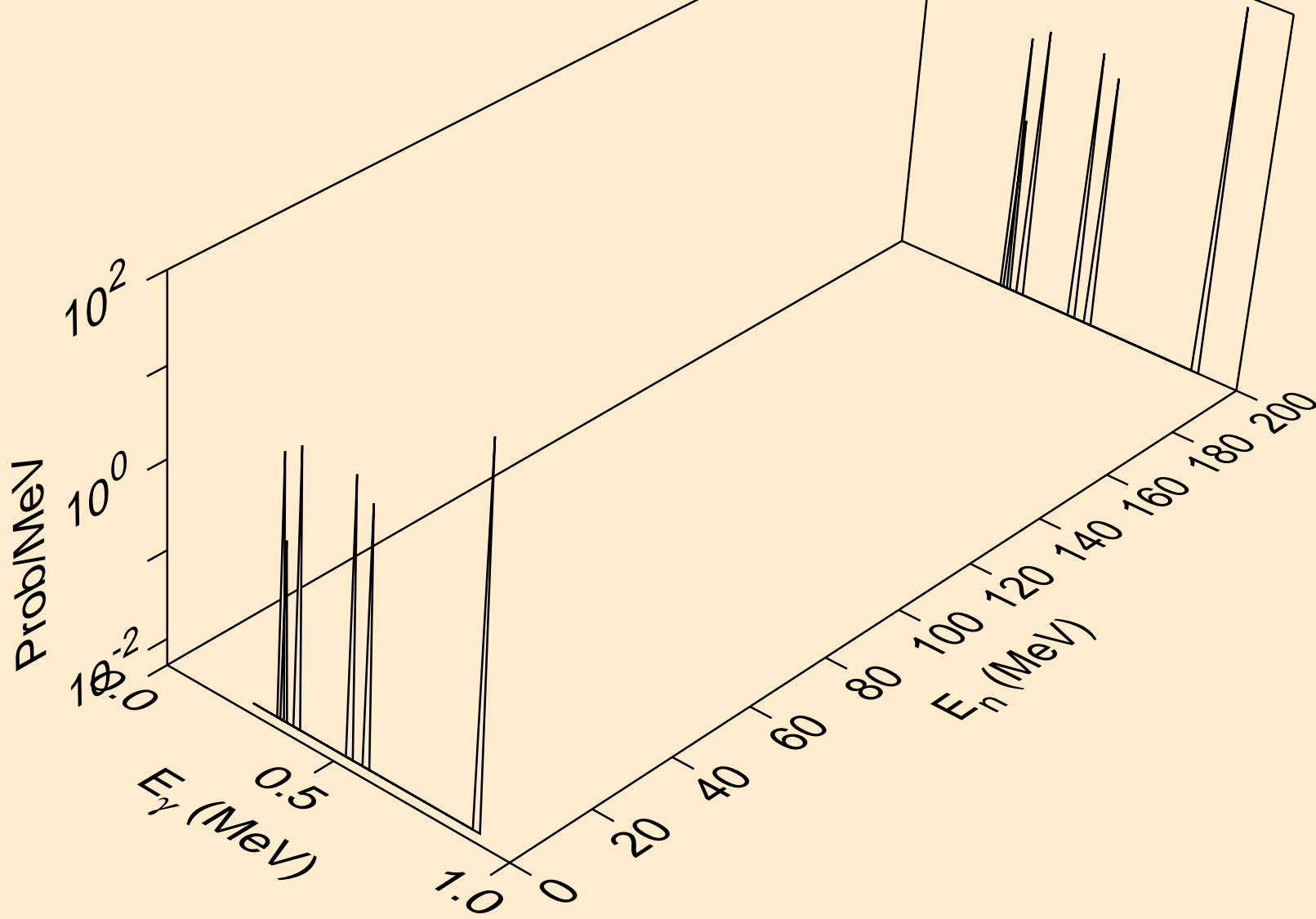

26-FE-58 FOR FENDL-3.2 FROM JEFF-3.1.1 BY NJOY2016.60+ ON
Photon emission for (n,a*5)

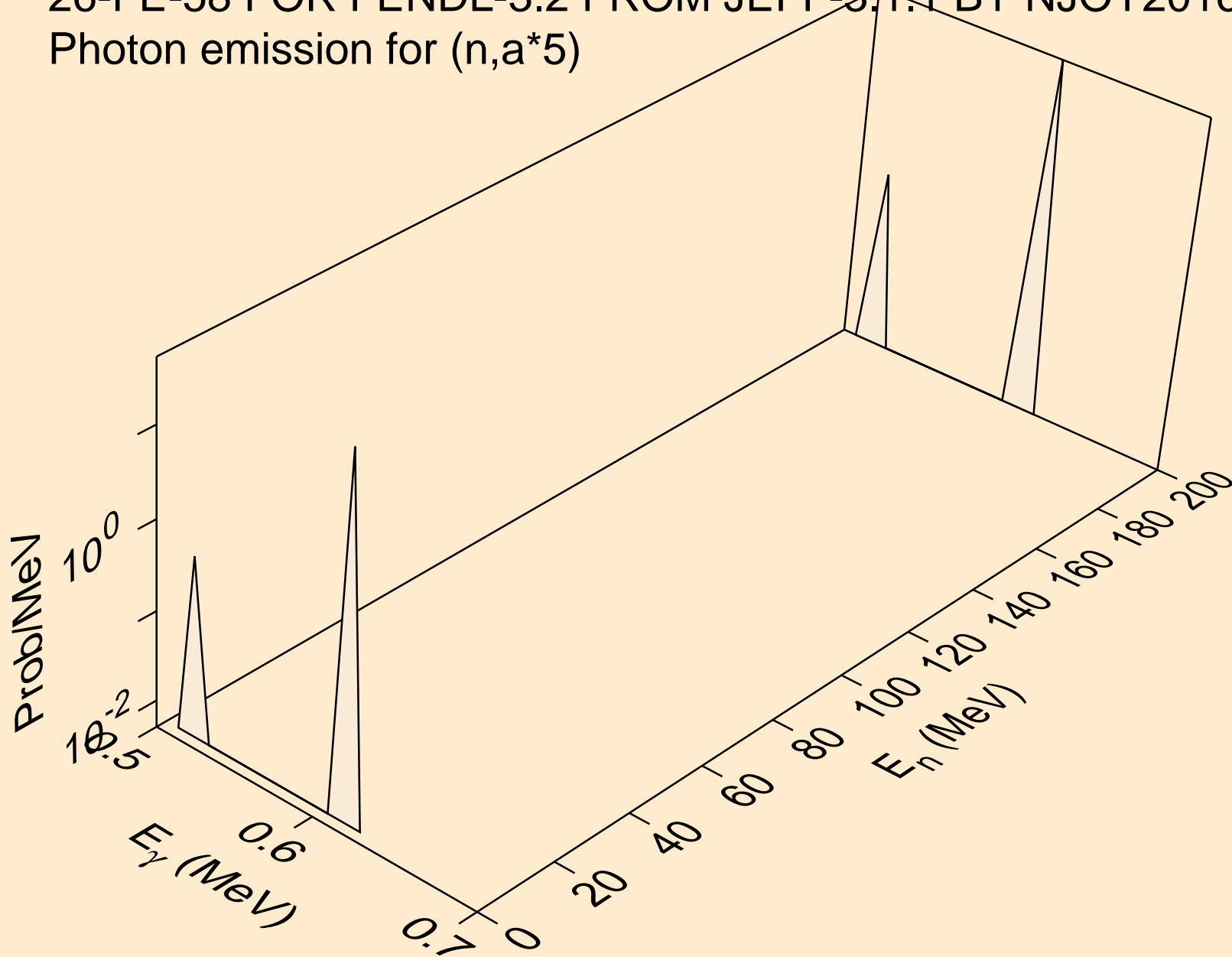

26-FE-58 FOR FENDL-3.2 FROM JEFF-3.1.1 BY NJOY2016.60+ ON
Photon emission for (n,a*6)

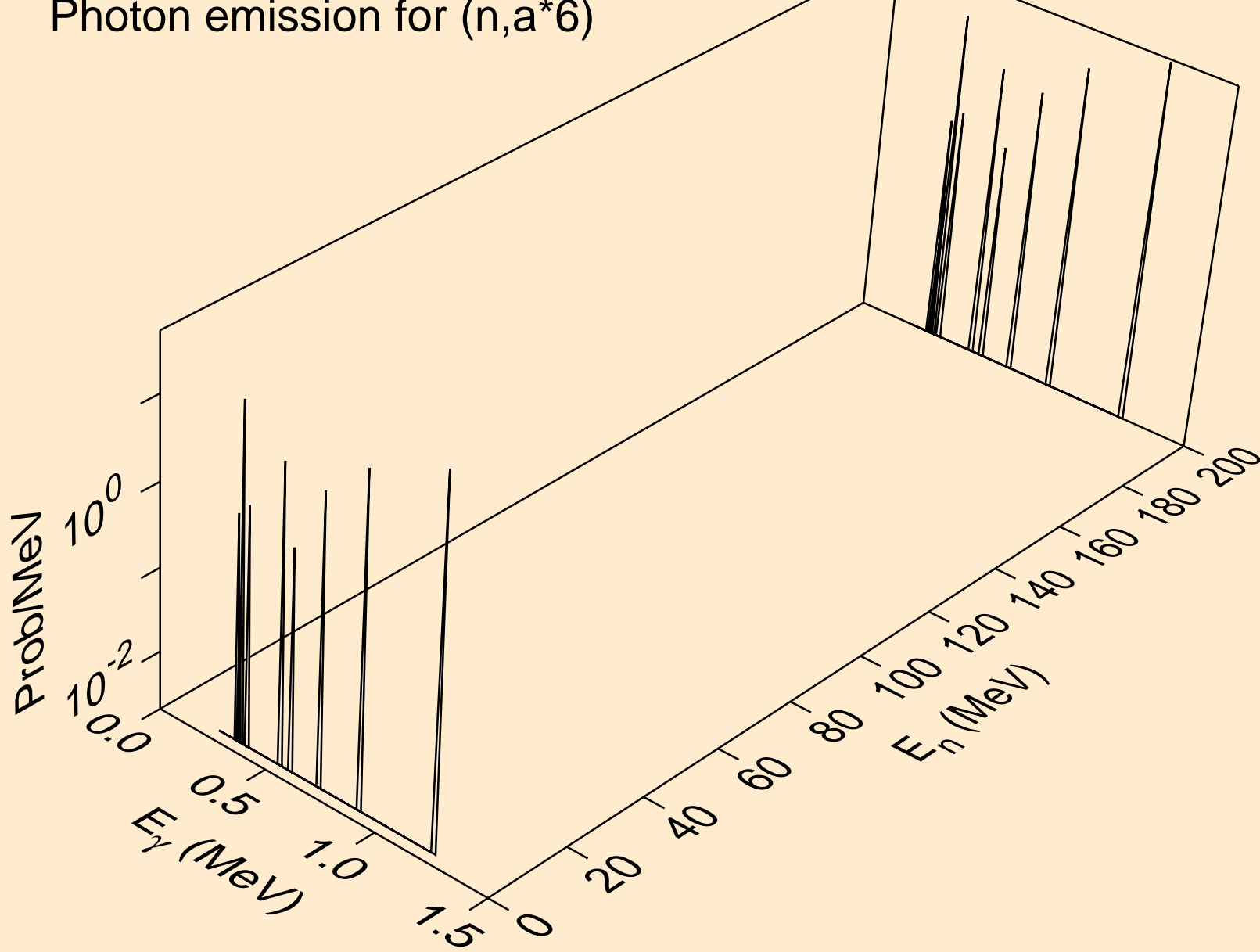

26-FE-58 FOR FENDL-3.2 FROM JEFF-3.1.1 BY NJOY2016.60+ ON
Photon emission for (n,a*7)

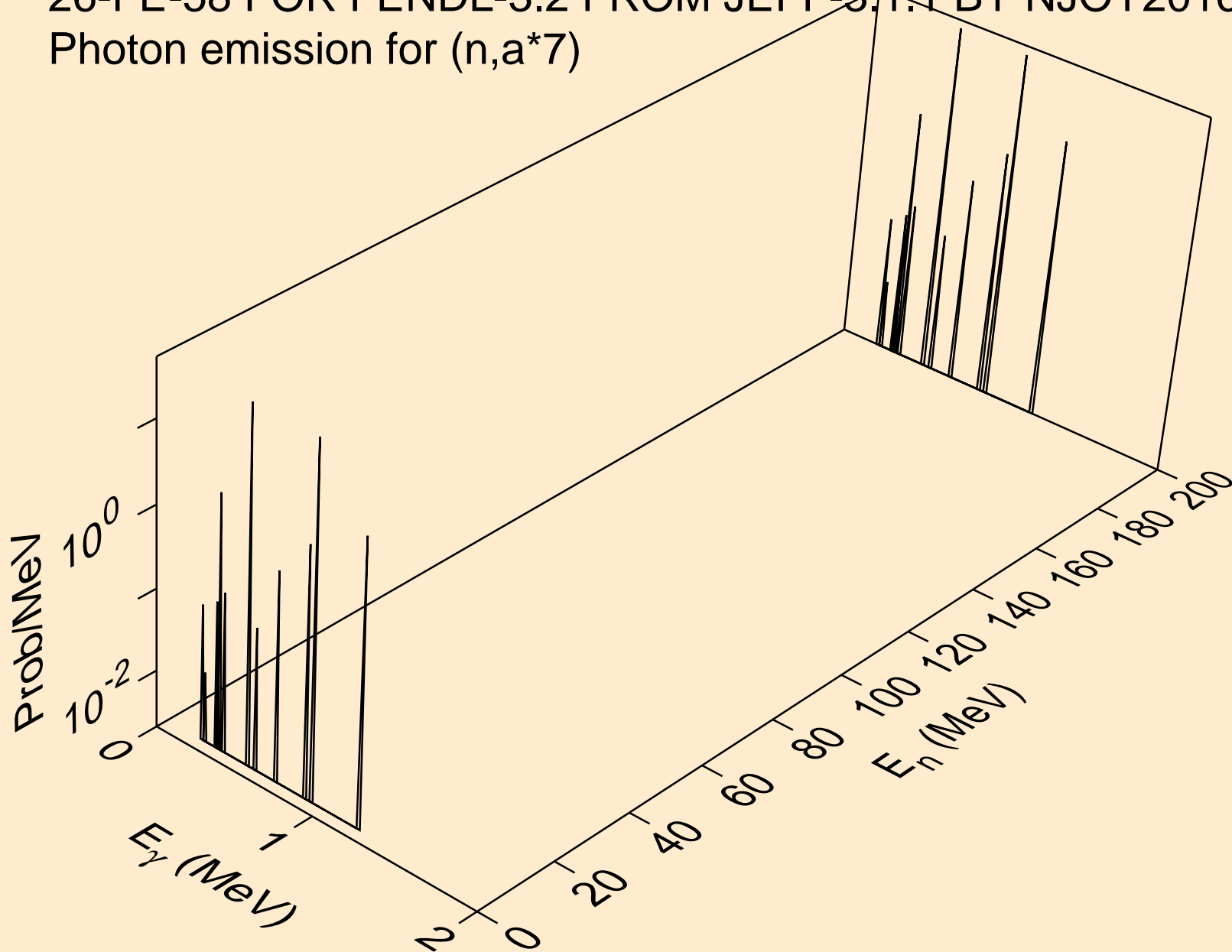

26-FE-58 FOR FENDL-3.2 FROM JEFF-3.1.1 BY NJOY2016.60+ ON
Photon emission for (n,a*8)

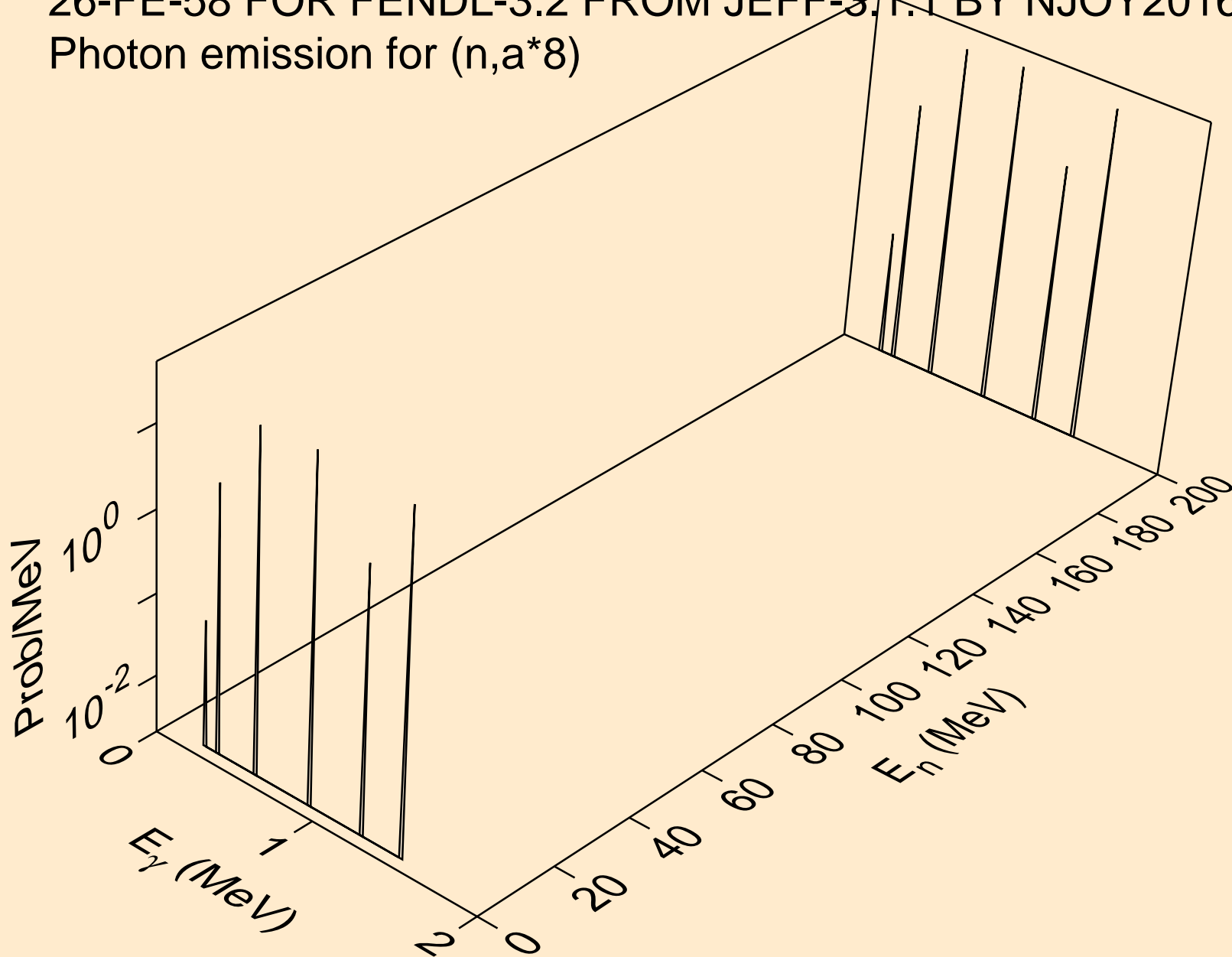

26-FE-58 FOR FENDL-3.2 FROM JEFF-3.1.1 BY NJOY2016.60+ ON
Photon emission for (n,a*9)

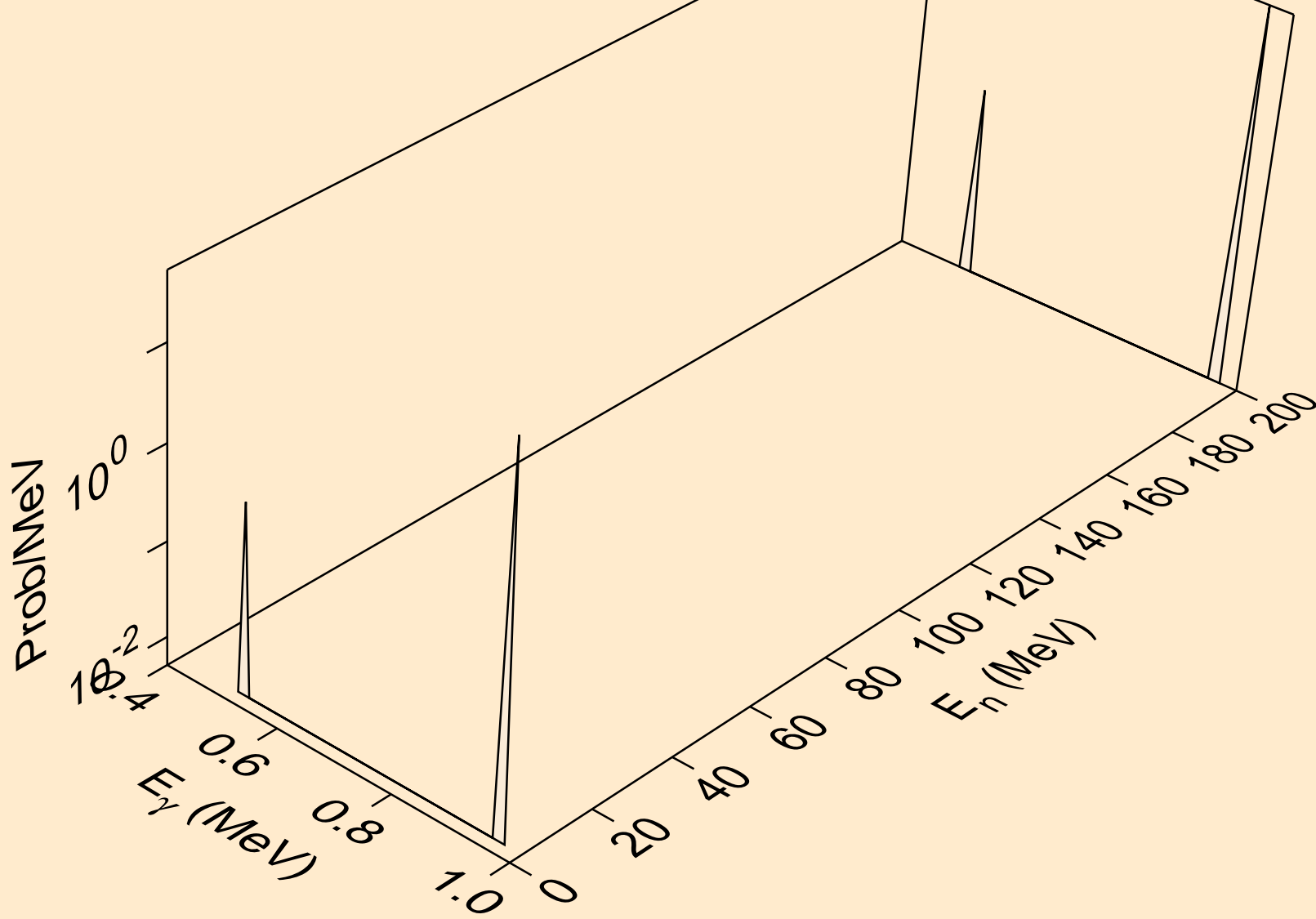

26-FE-58 FOR FENDL-3.2 FROM JEFF-3.1.1 BY NJOY2016.60+ ON
Photon emission for (n,a*10)

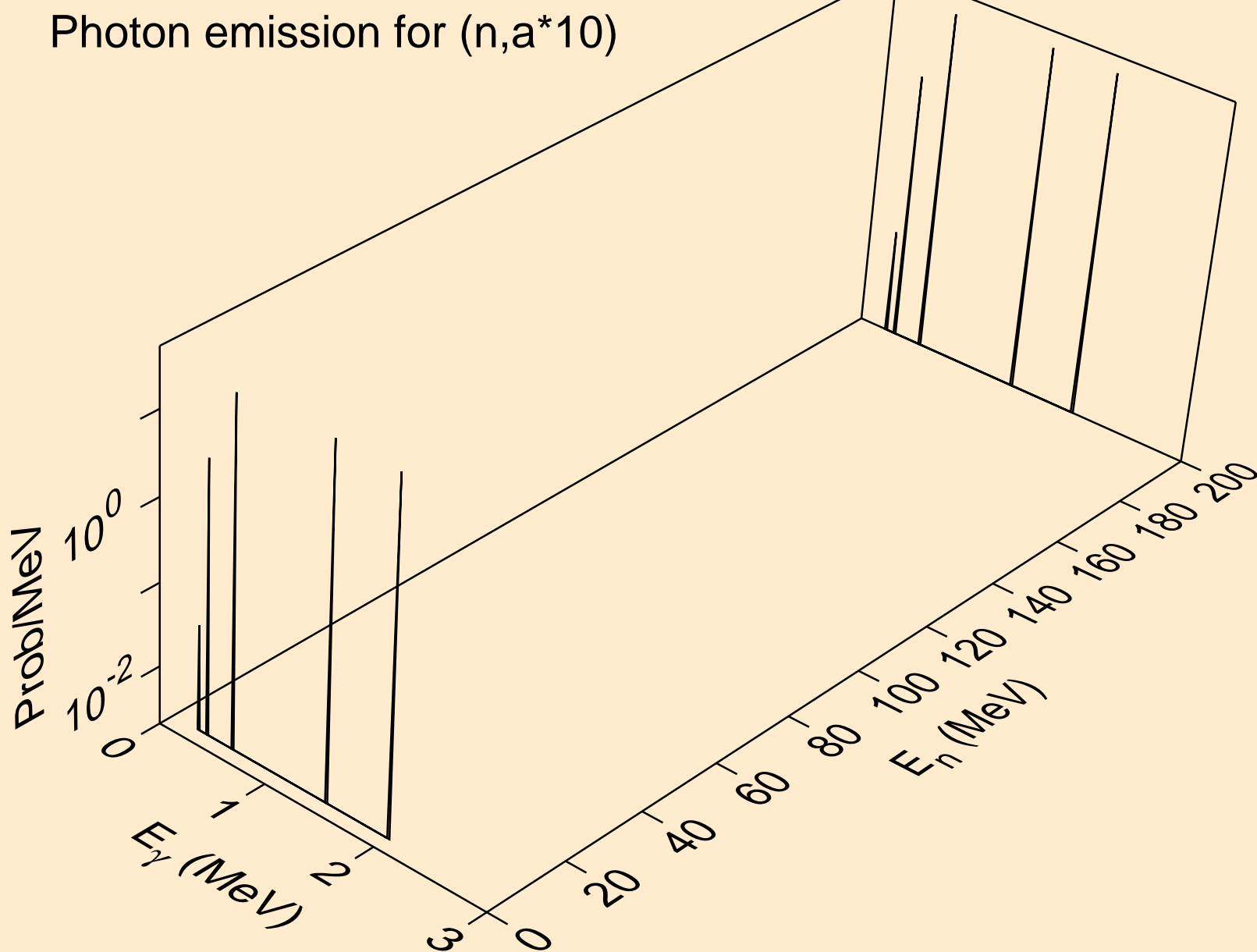

26-FE-58 FOR FENDL-3.2 FROM JEFF-3.1.1 BY NJOY2016.60+ ON
Photon emission for (n,a*c)

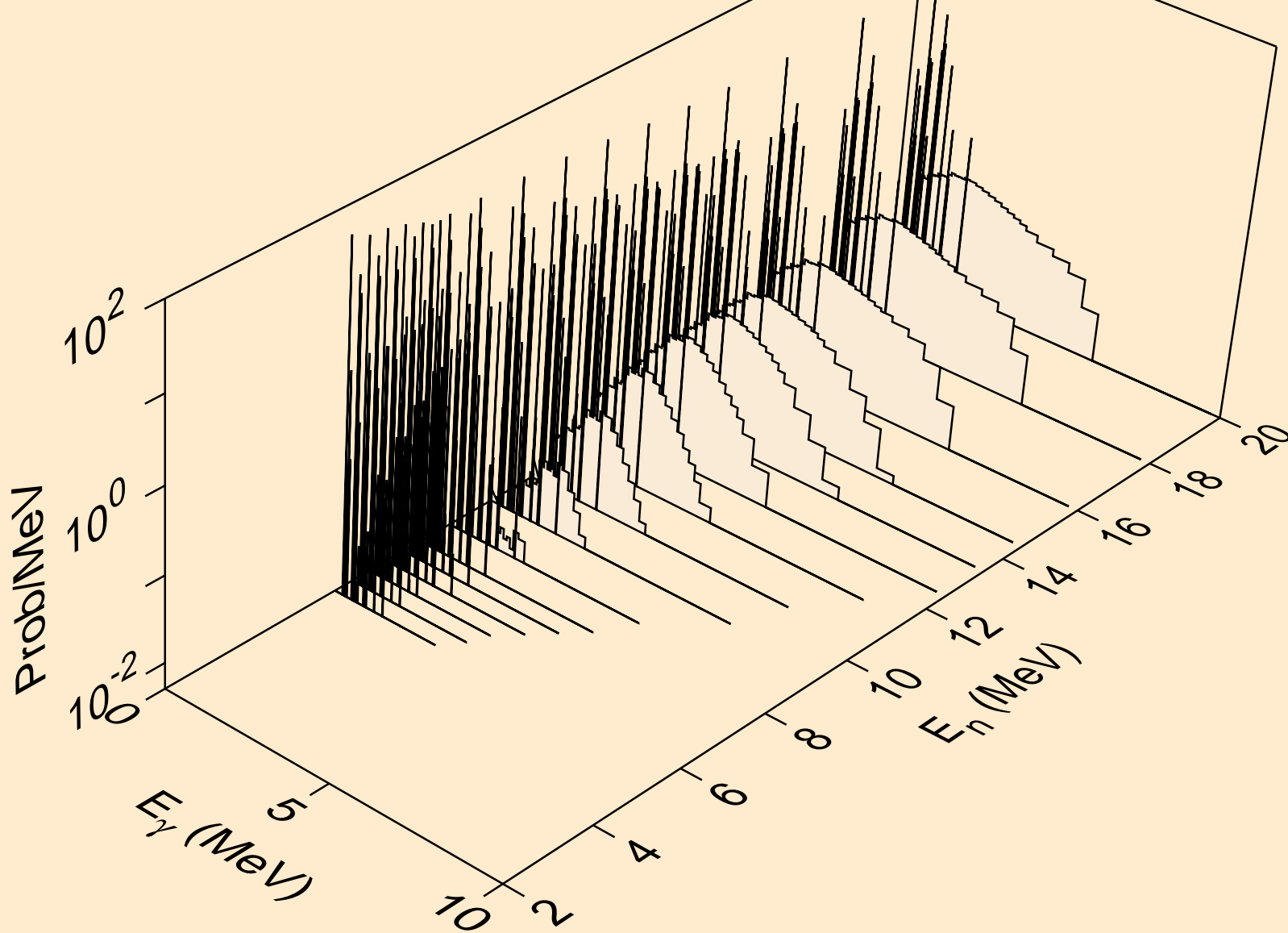

26-FE-58 FOR FENDL-3.2 FROM JEFF-3.1.1 BY NJOY2016.60+ ON
thermal capture photon spectrum

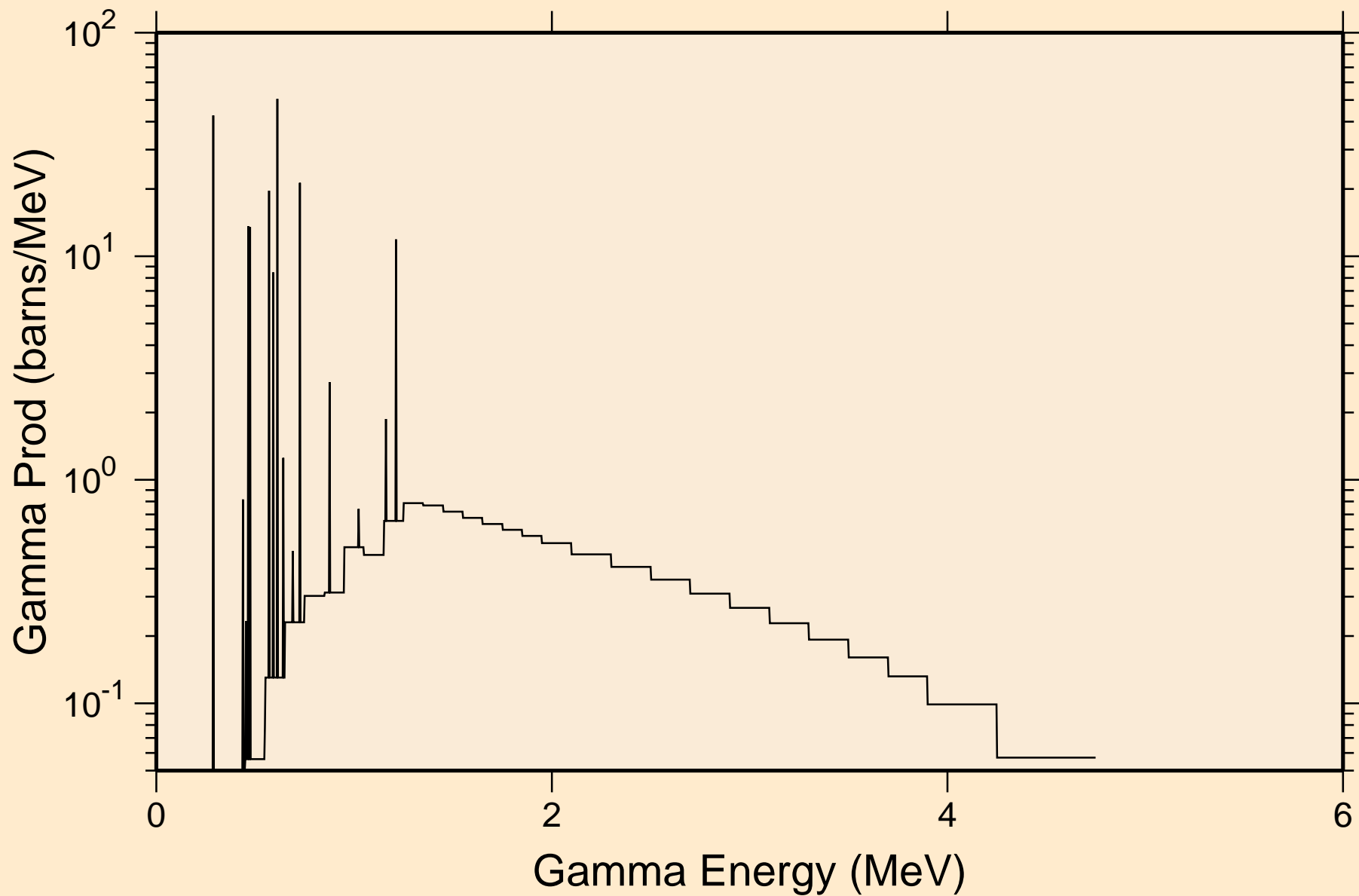

26-FE-58 FOR FENDL-3.2 FROM JEFF-3.1.1 BY NJOY2016.60+ ON
14 MeV photon spectrum

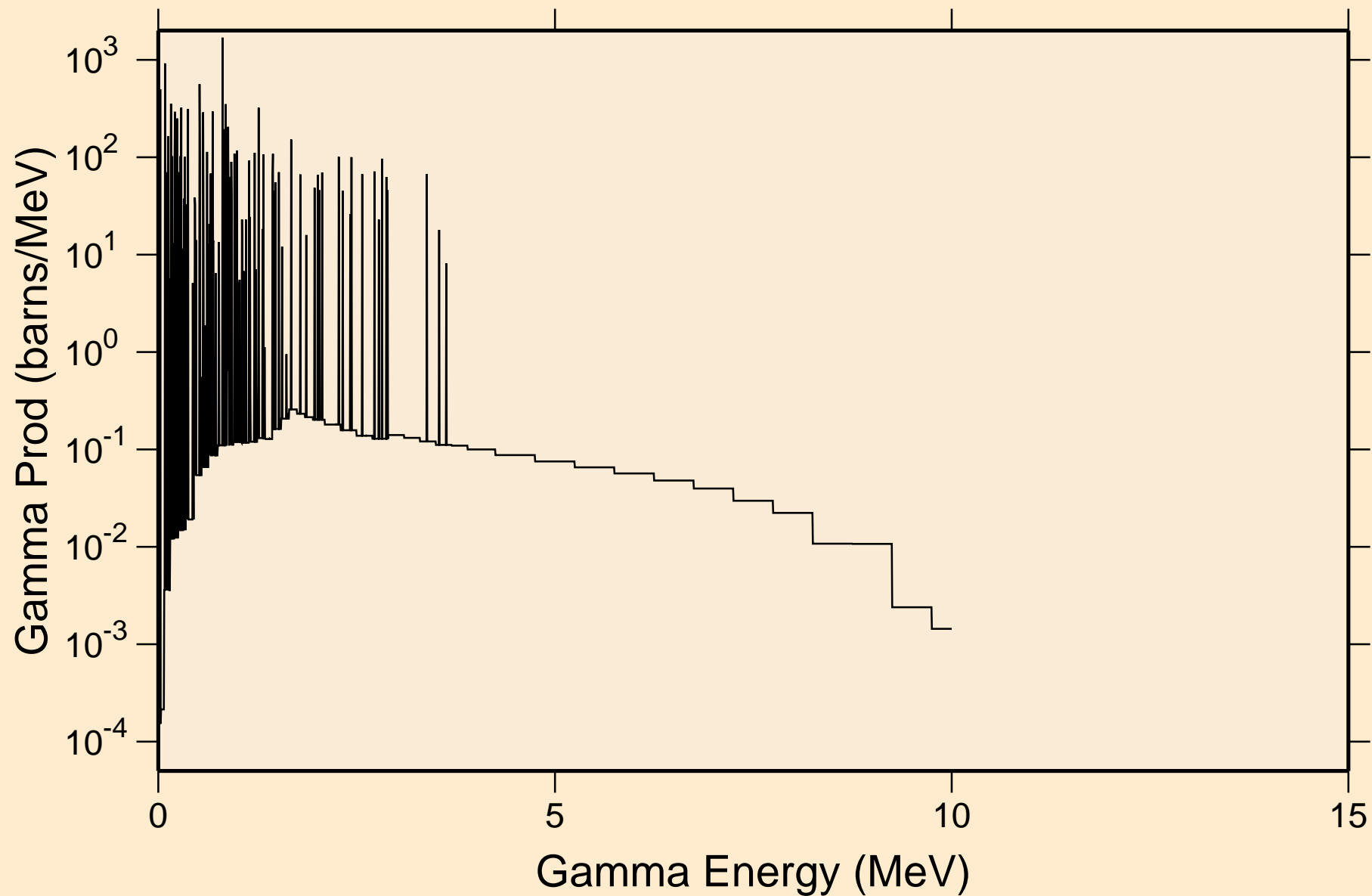

26-FE-58 FOR FENDL-3.2 FROM JEFF-3.1.1 BY NJOY2016.60+ ON Particle heating contributions

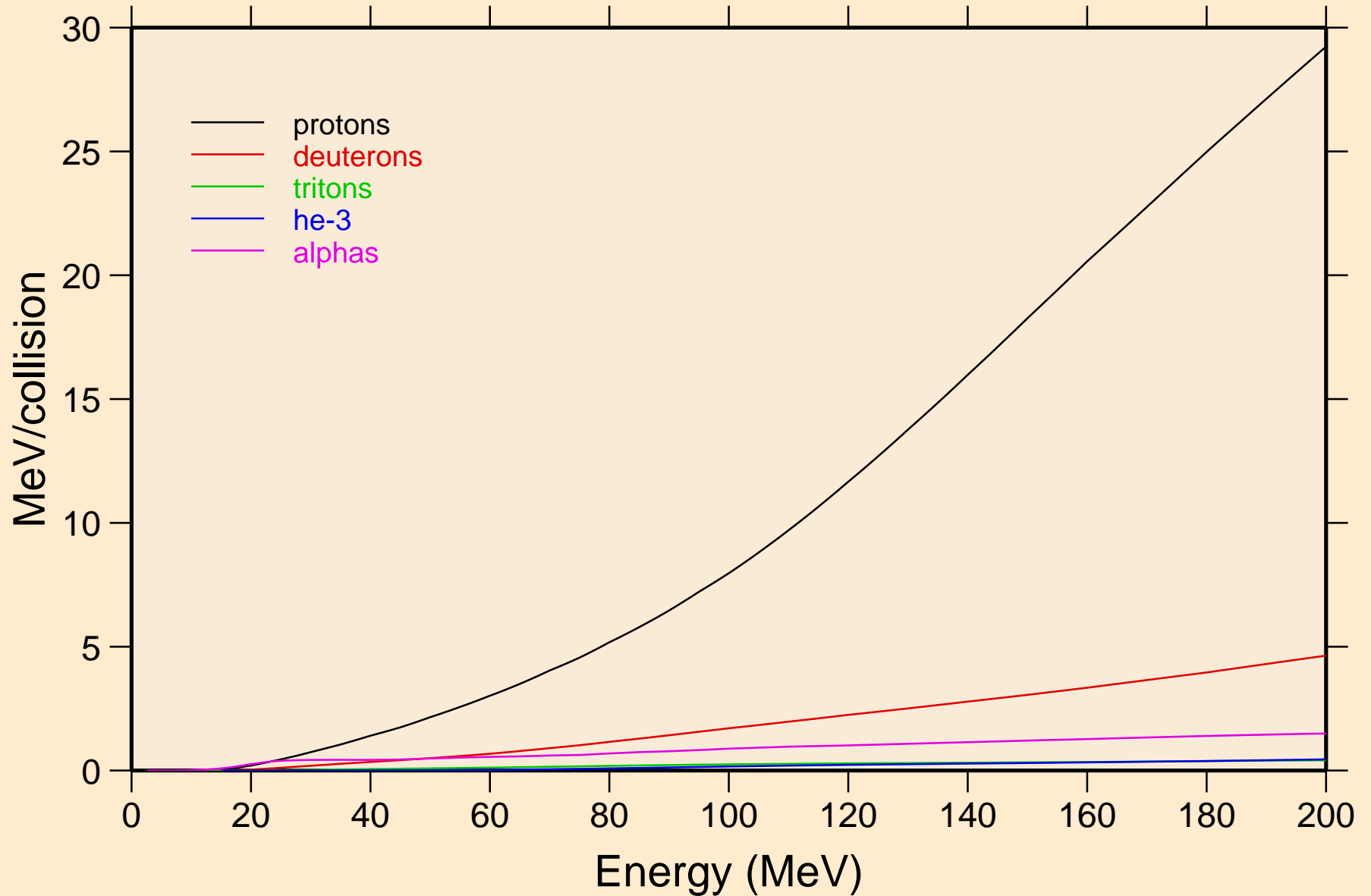

26-FE-58 FOR FENDL-3.2 FROM JEFF-3.1.1 BY NJOY2016.60+ ON
Recoil Heating

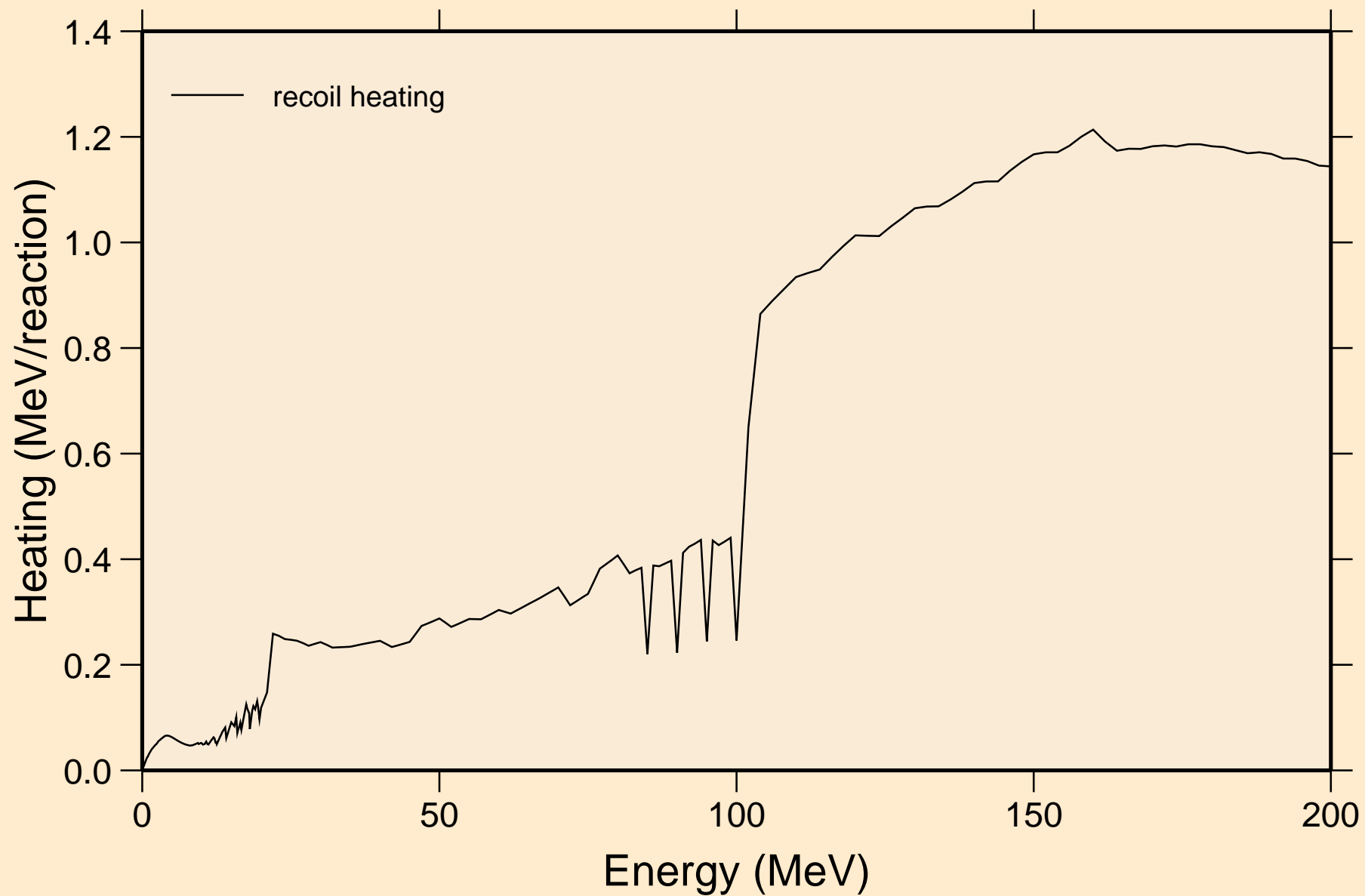

26-FE-58 FOR FENDL-3.2 FROM JEFF-3.1.1 BY NJOY2016.60+ ON
Particle production cross sections

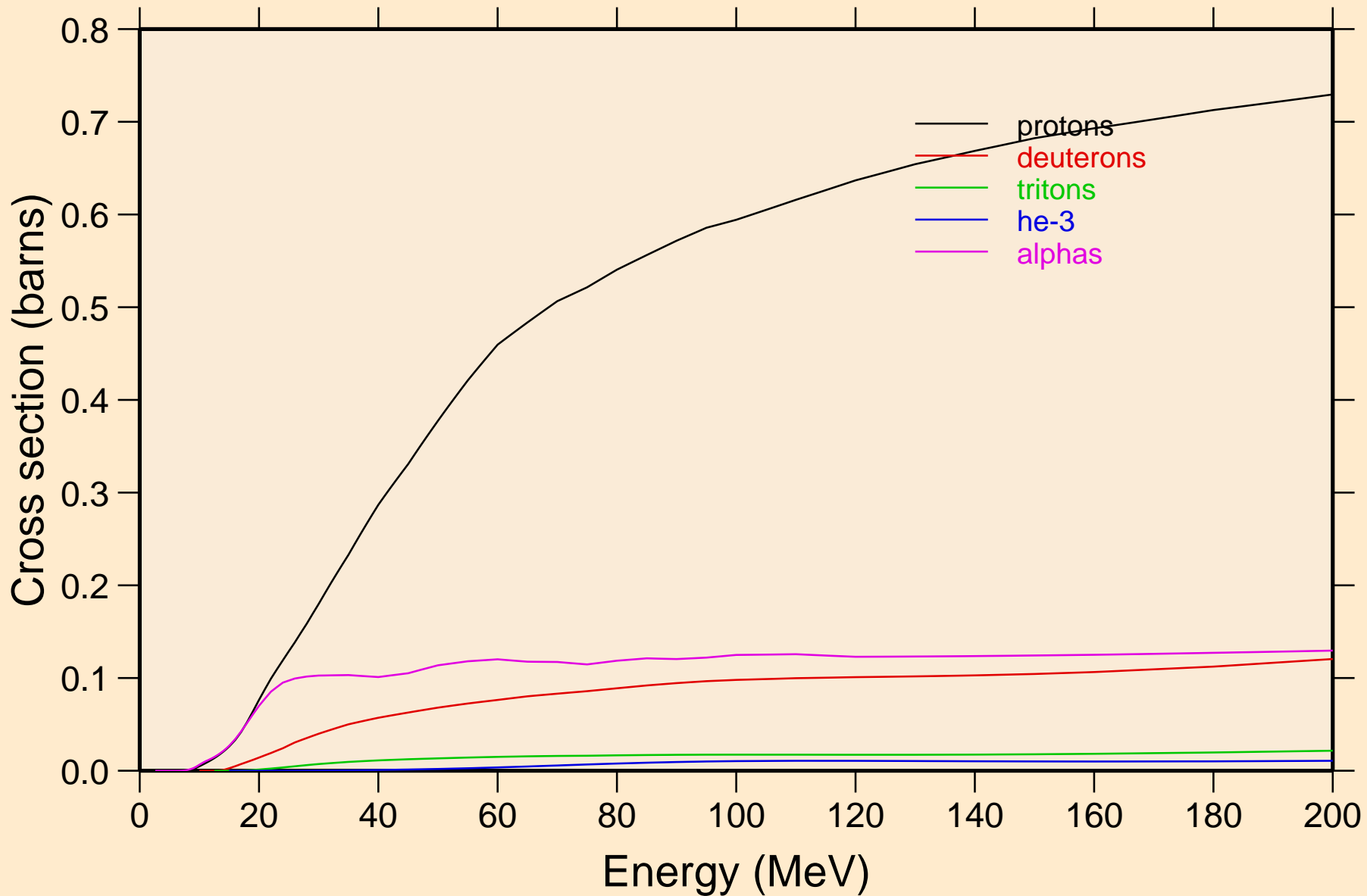

26-FE-58 FOR FENDL-3.2 FROM JEFF-3.1.1 BY NJOY2016.60+ ON
protons from (n,x)

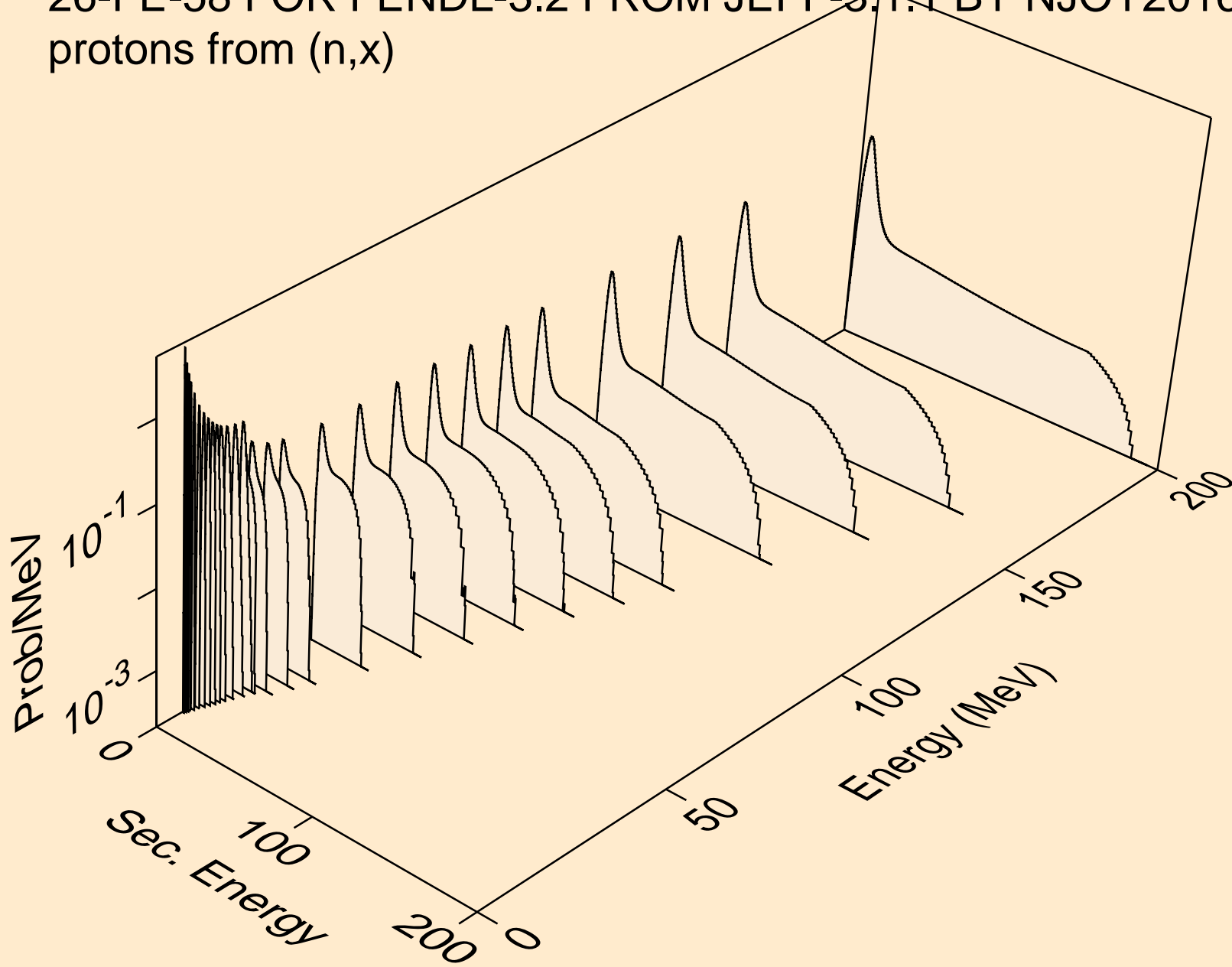

26-FE-58 FOR FENDL-3.2 FROM JEFF-3.1.1 BY NJOY2016.60+ ON
protons from (n,n*)p

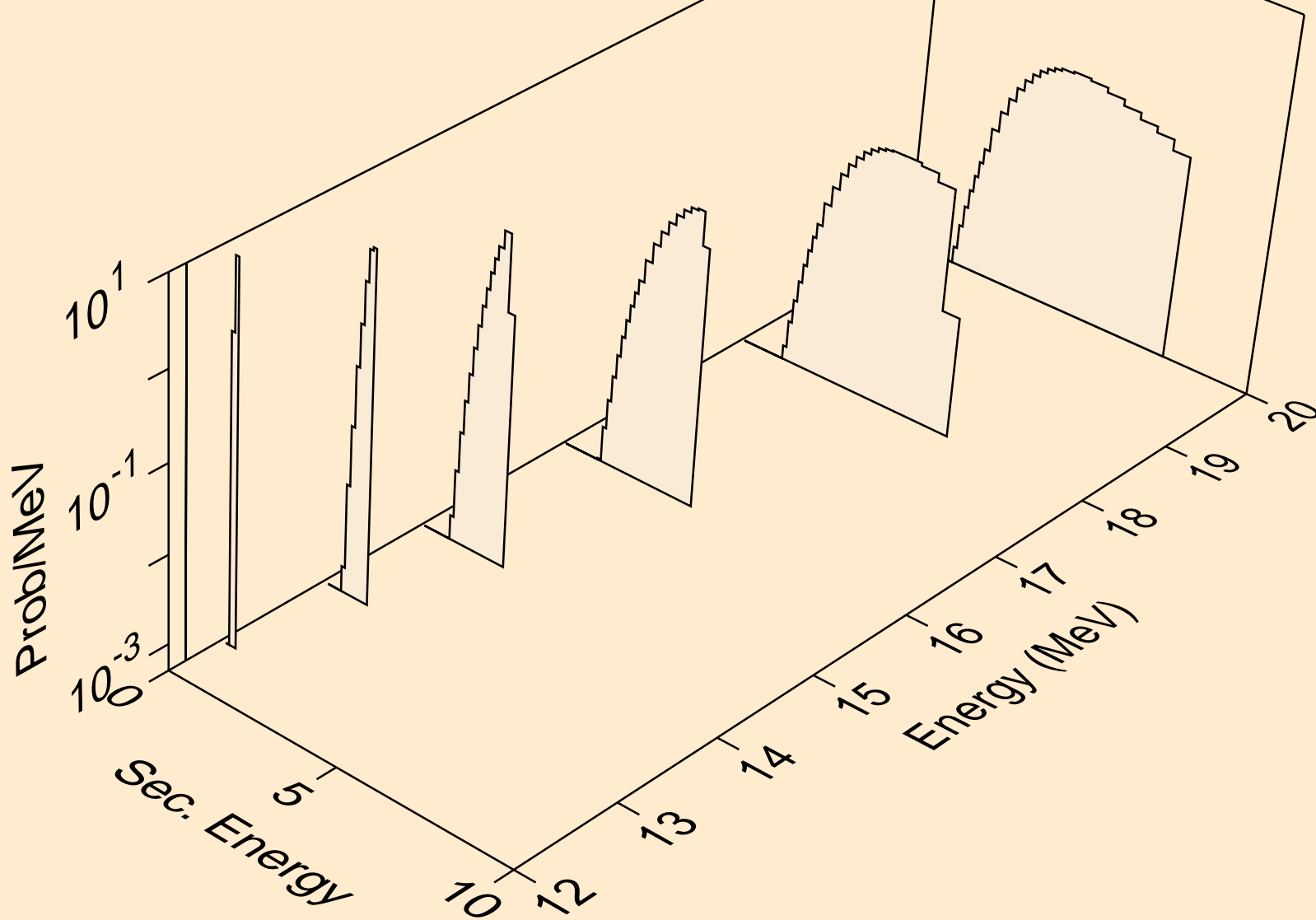

26-FE-58 FOR FENDL-3.2 FROM JEFF-3.1.1 BY NJOY2016.60+ ON
angular distribution for (n,p*0) proton

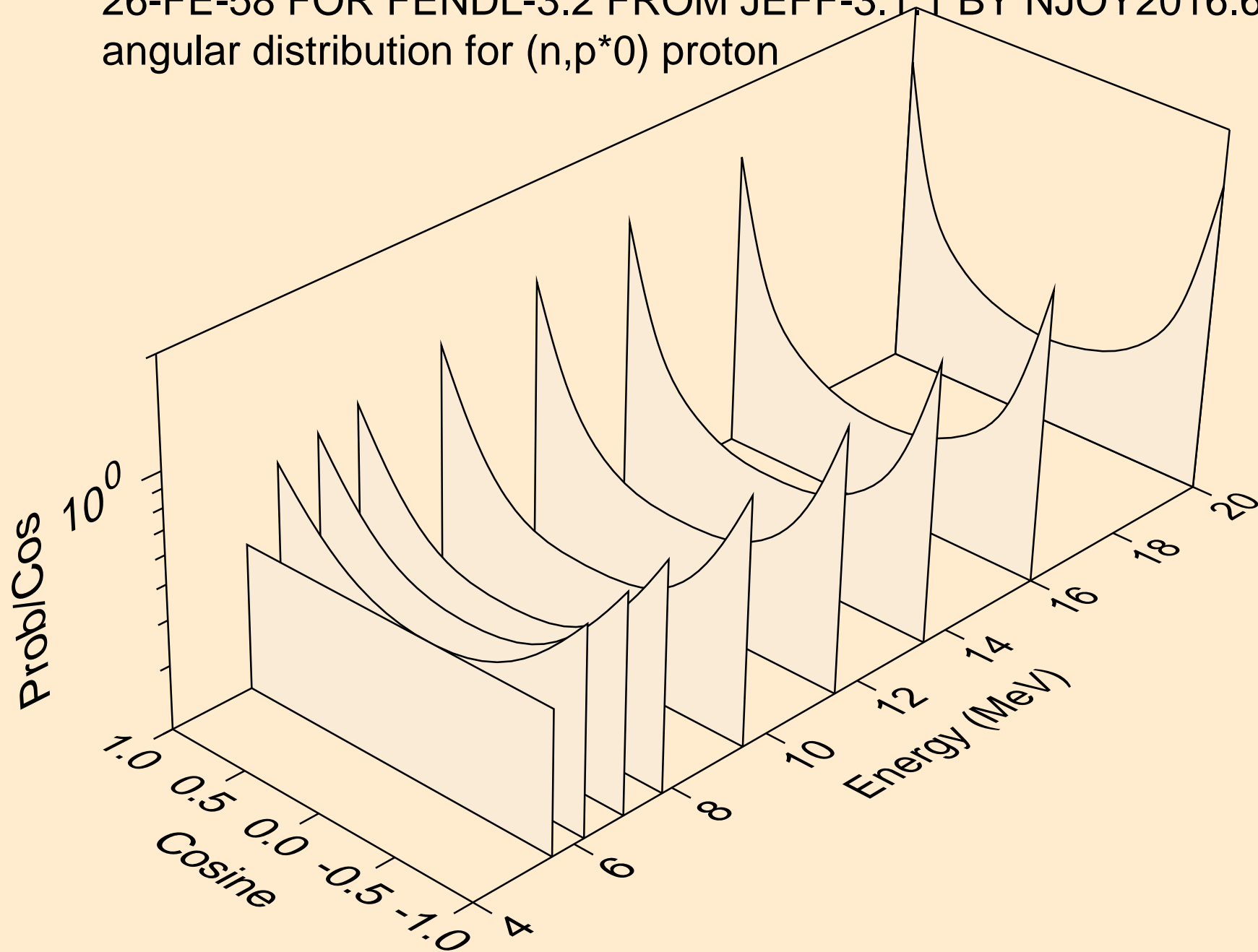

26-FE-58 FOR FENDL-3.2 FROM JEFF-3.1.1 BY NJOY2016.60+ ON
angular distribution for (n,p*1) proton

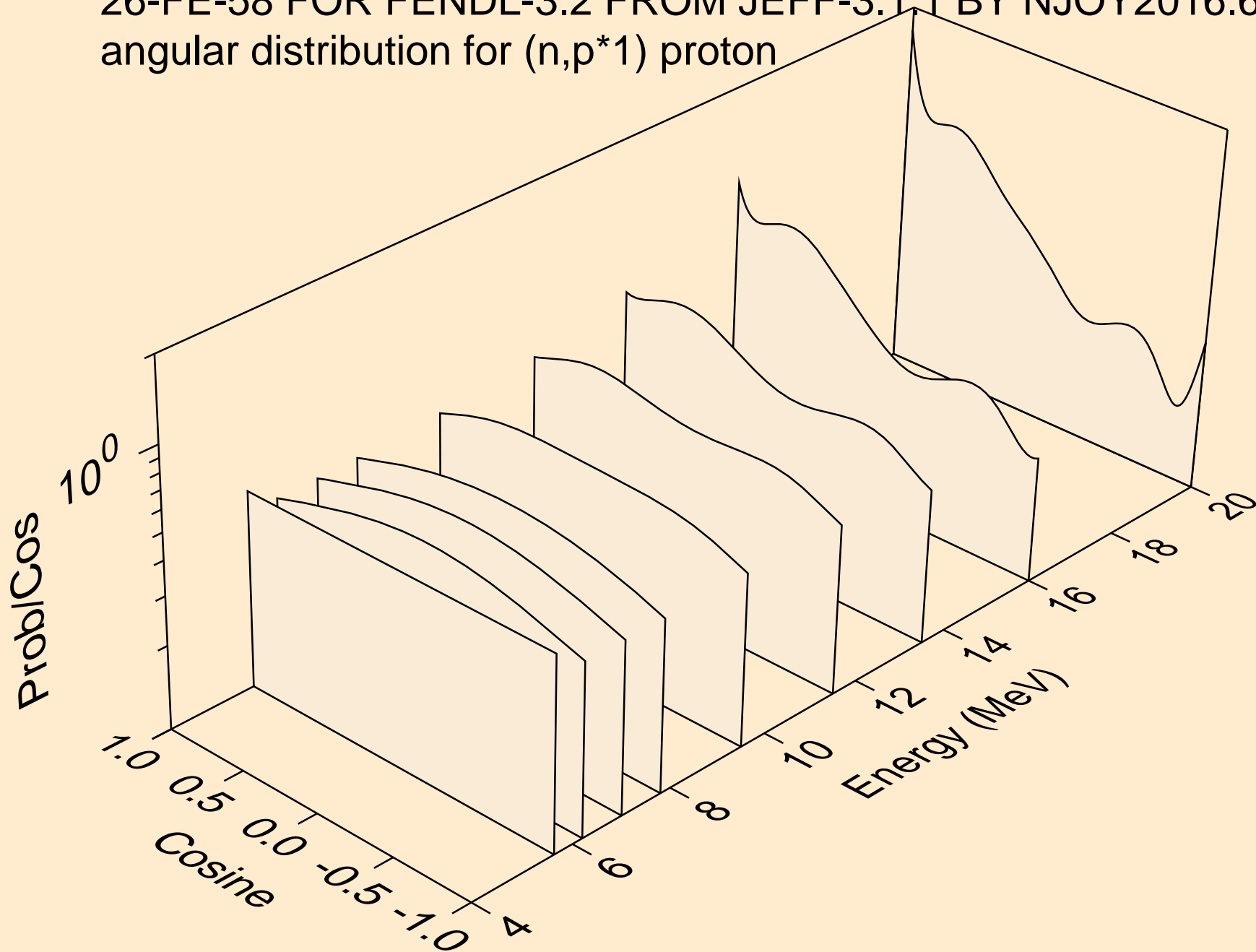

26-FE-58 FOR FENDL-3.2 FROM JEFF-3.1.1 BY NJOY2016.60+ ON
angular distribution for (n,p*2) proton

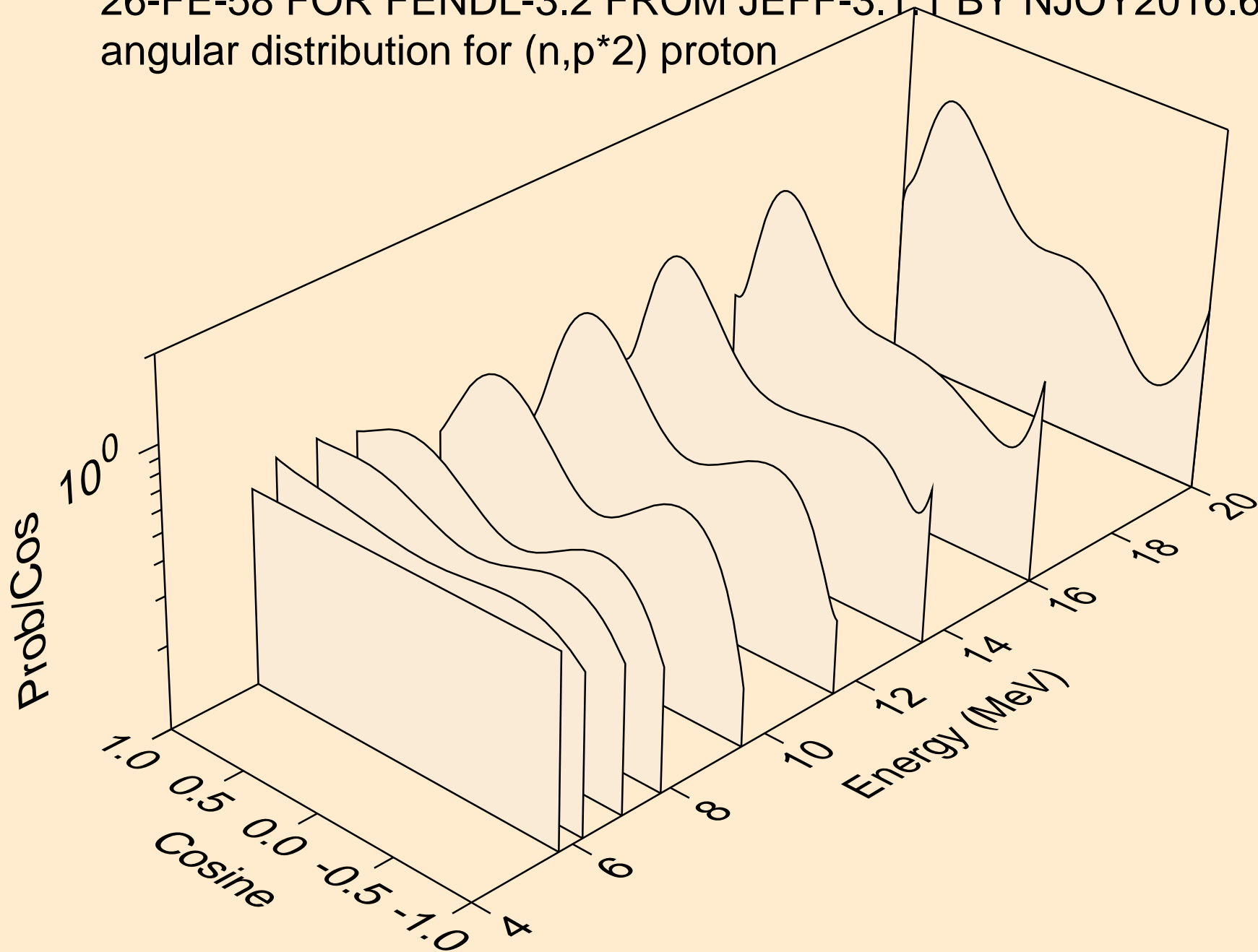

26-FE-58 FOR FENDL-3.2 FROM JEFF-3.1.1 BY NJOY2016.60+ ON
angular distribution for (n,p*3) proton

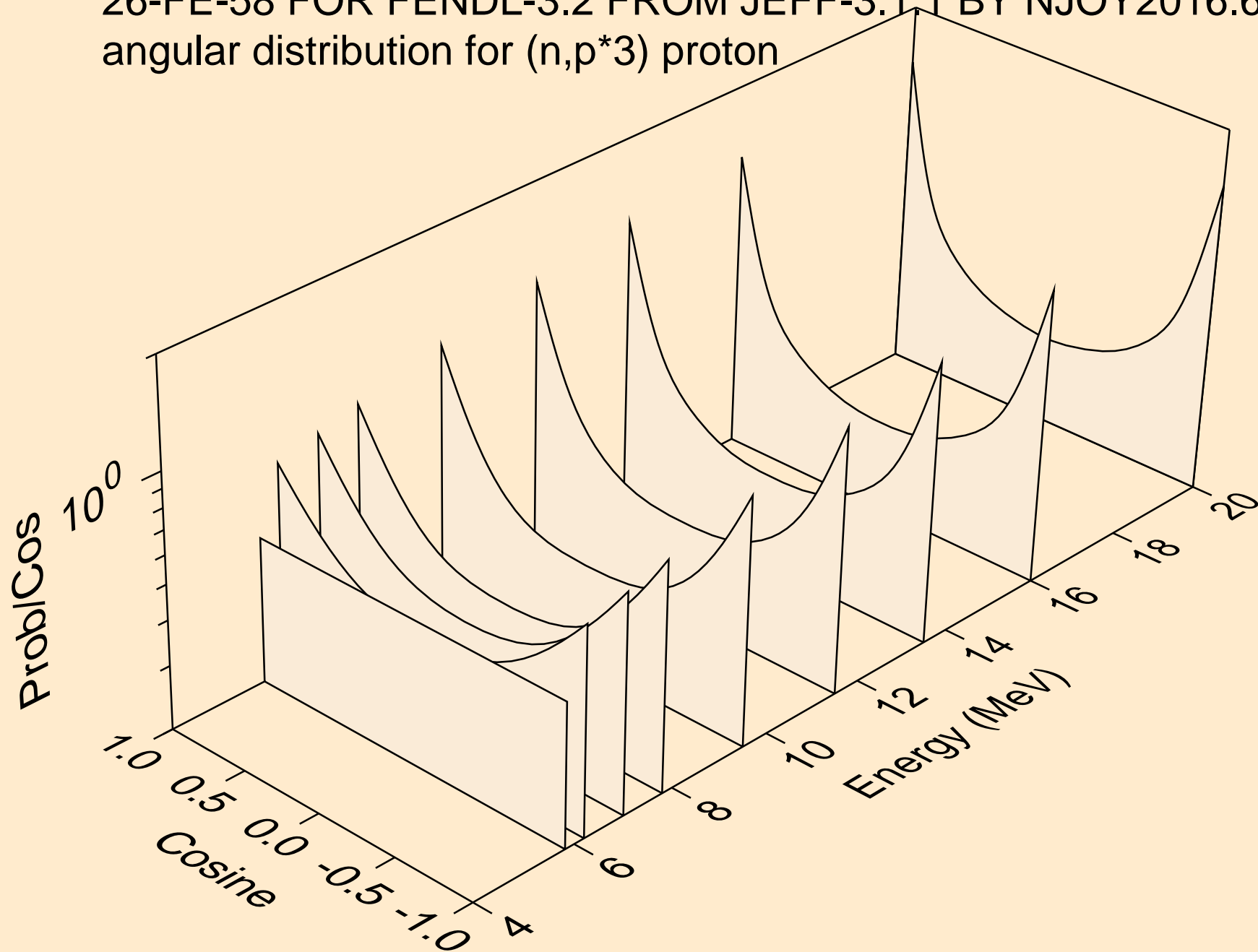

26-FE-58 FOR FENDL-3.2 FROM JEFF-3.1.1 BY NJOY2016.60+ ON
angular distribution for (n,p*4) proton

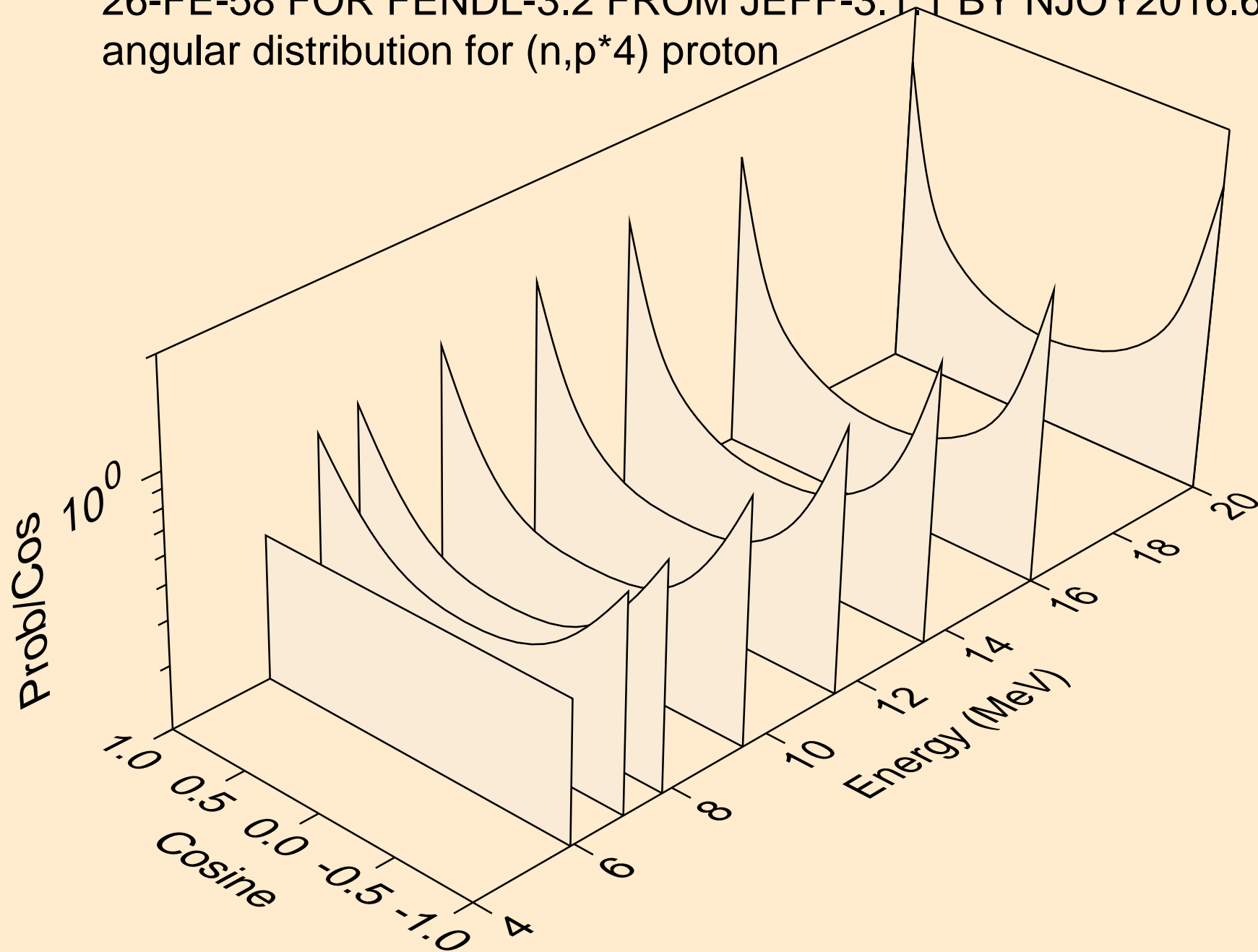

26-FE-58 FOR FENDL-3.2 FROM JEFF-3.1.1 BY NJOY2016.60+ ON
angular distribution for (n,p*5) proton

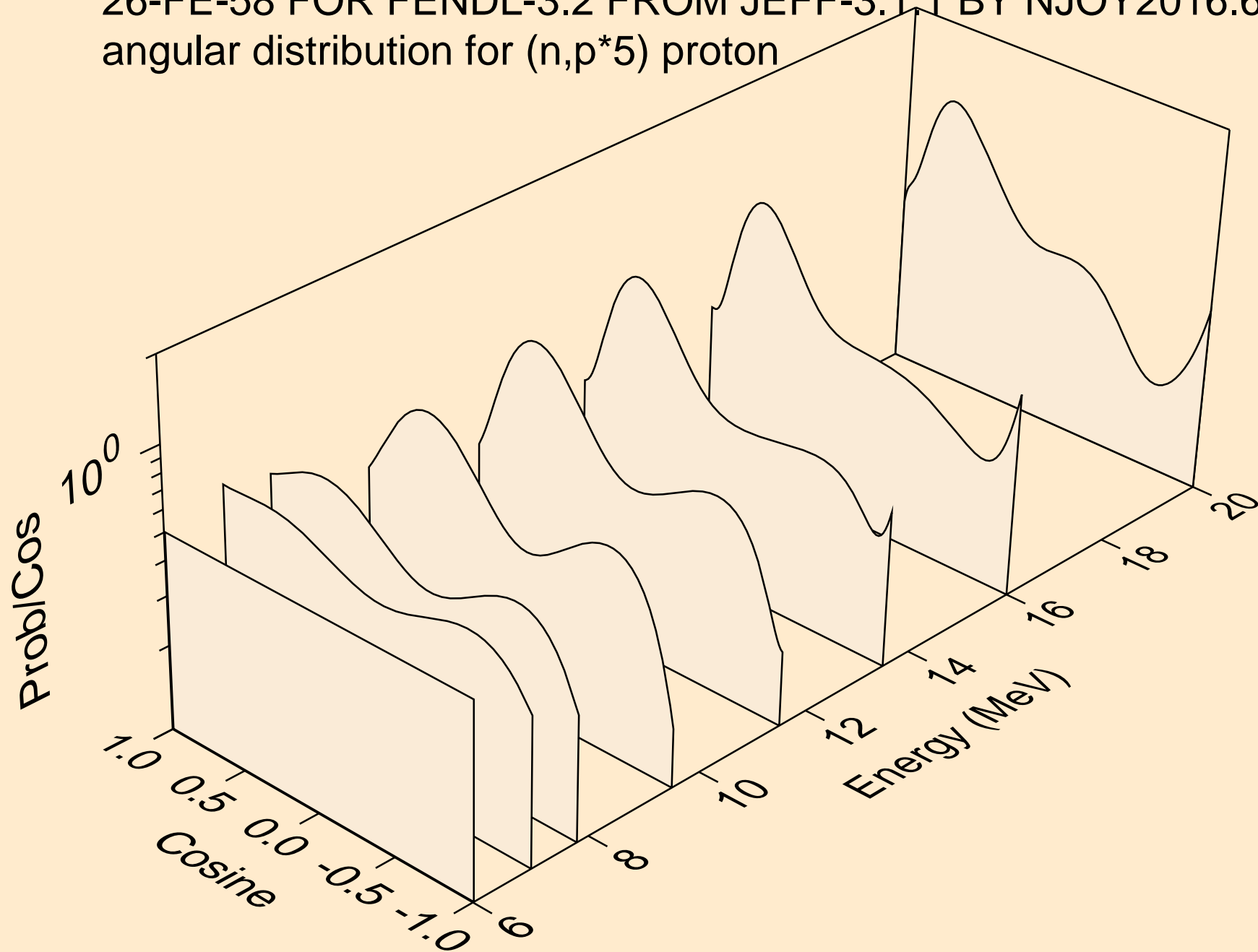

26-FE-58 FOR FENDL-3.2 FROM JEFF-3.1.1 BY NJOY2016.60+ ON
angular distribution for (n,p*6) proton

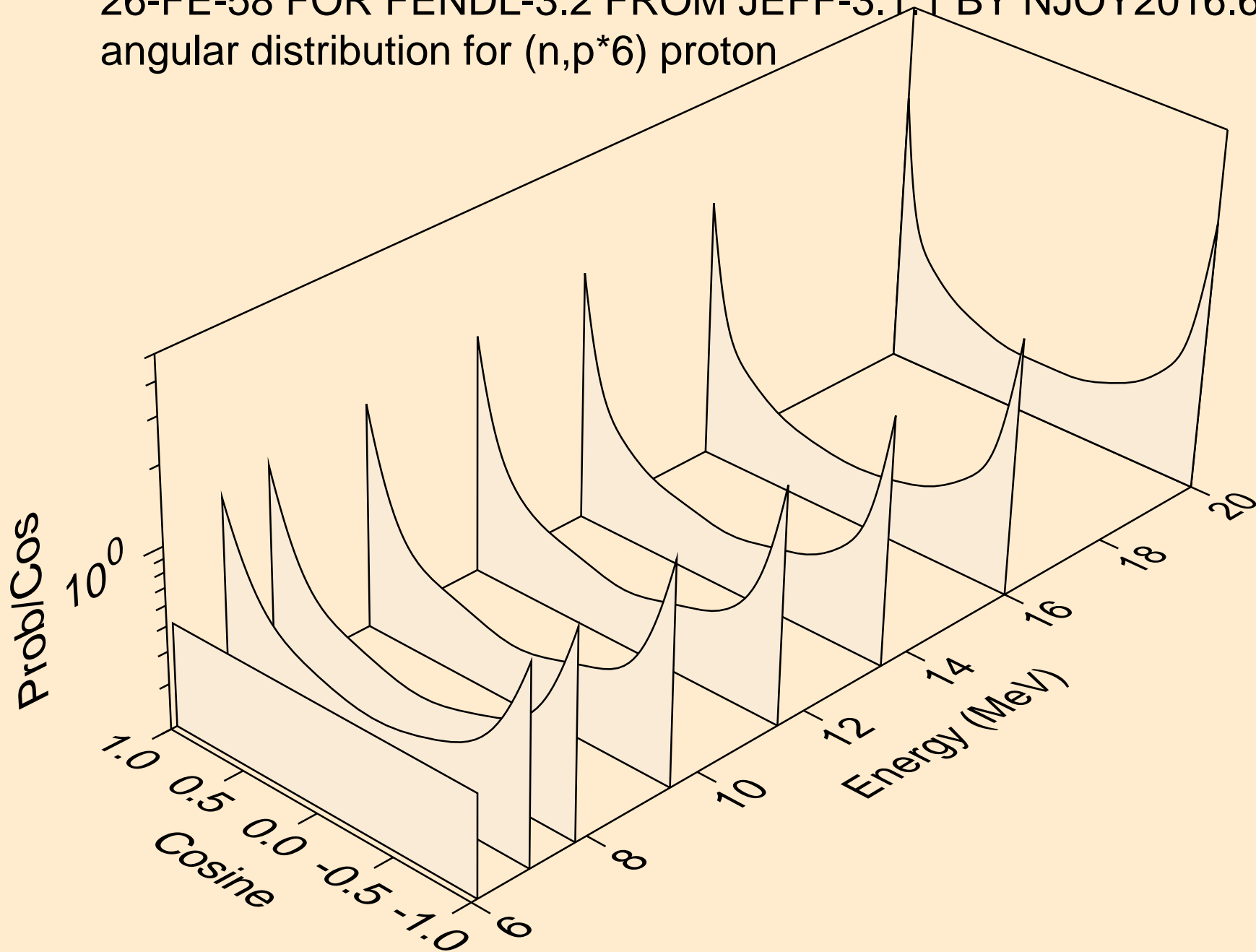

26-FE-58 FOR FENDL-3.2 FROM JEFF-3.1.1 BY NJOY2016.60+ ON
angular distribution for (n,p*7) proton

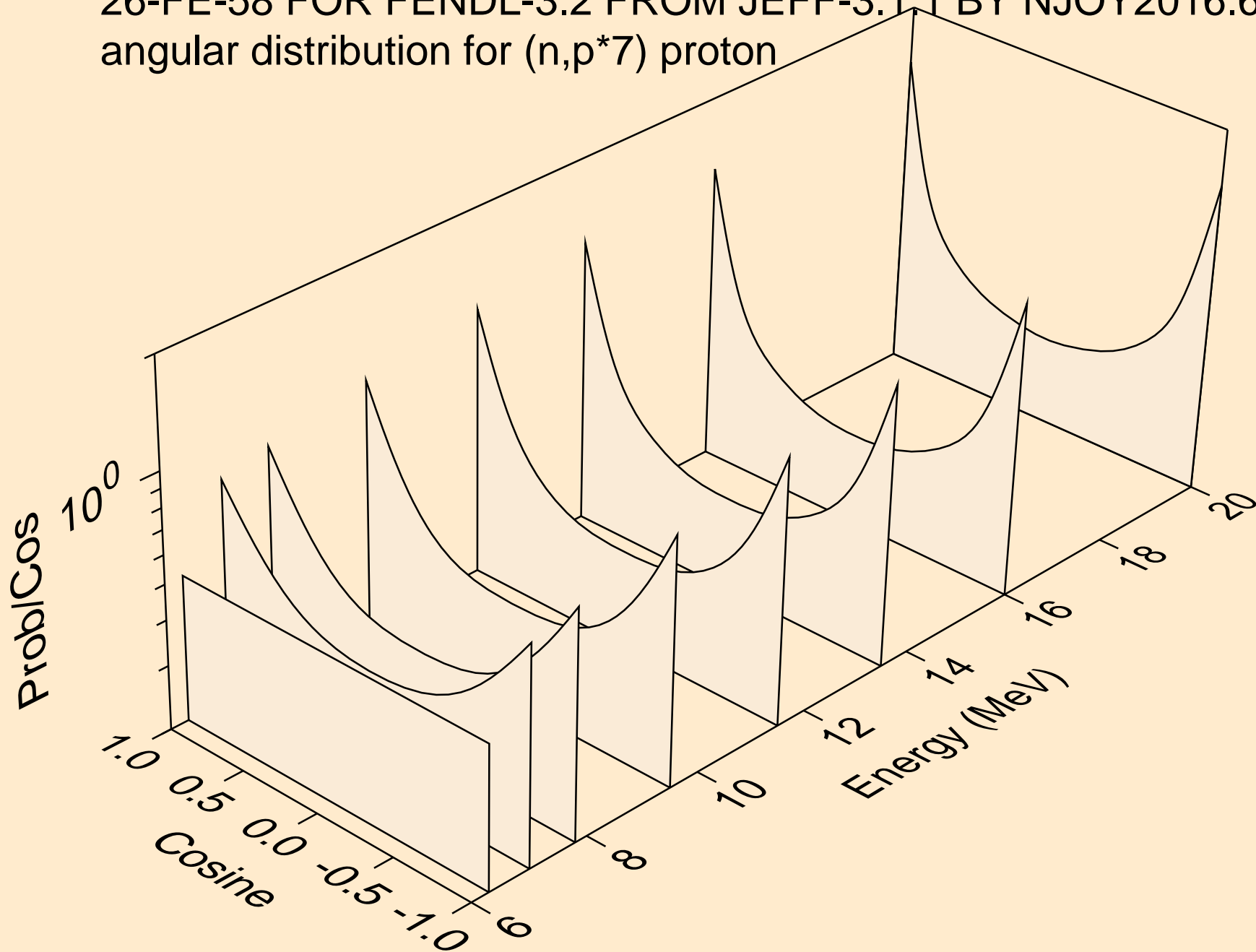

26-FE-58 FOR FENDL-3.2 FROM JEFF-3.1.1 BY NJOY2016.60+ ON
angular distribution for (n,p*8) proton

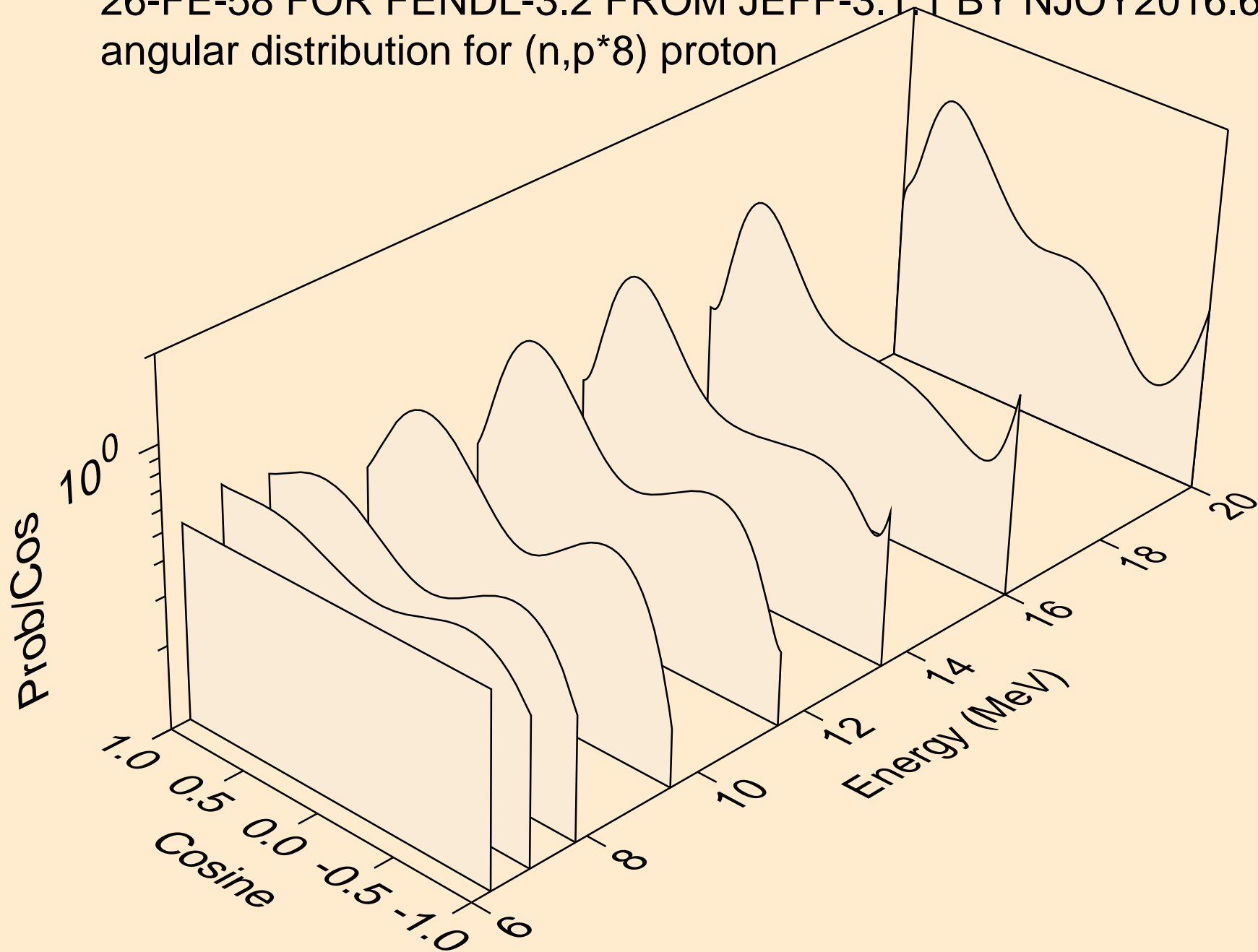

26-FE-58 FOR FENDL-3.2 FROM JEFF-3.1.1 BY NJOY2016.60+ ON
angular distribution for (n,p*9) proton

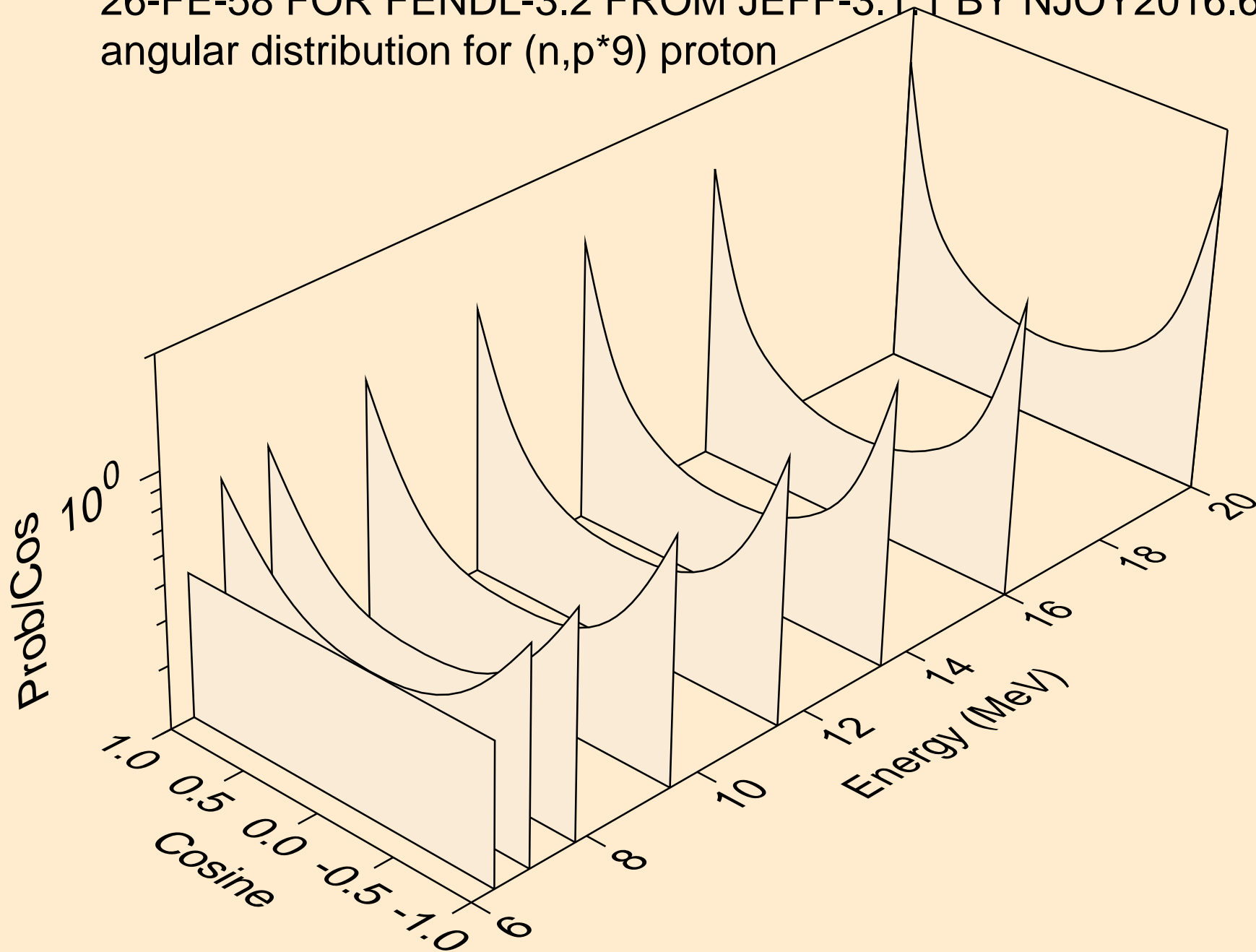

26-FE-58 FOR FENDL-3.2 FROM JEFF-3.1.1 BY NJOY2016.60+ ON
angular distribution for (n,p*10) proton

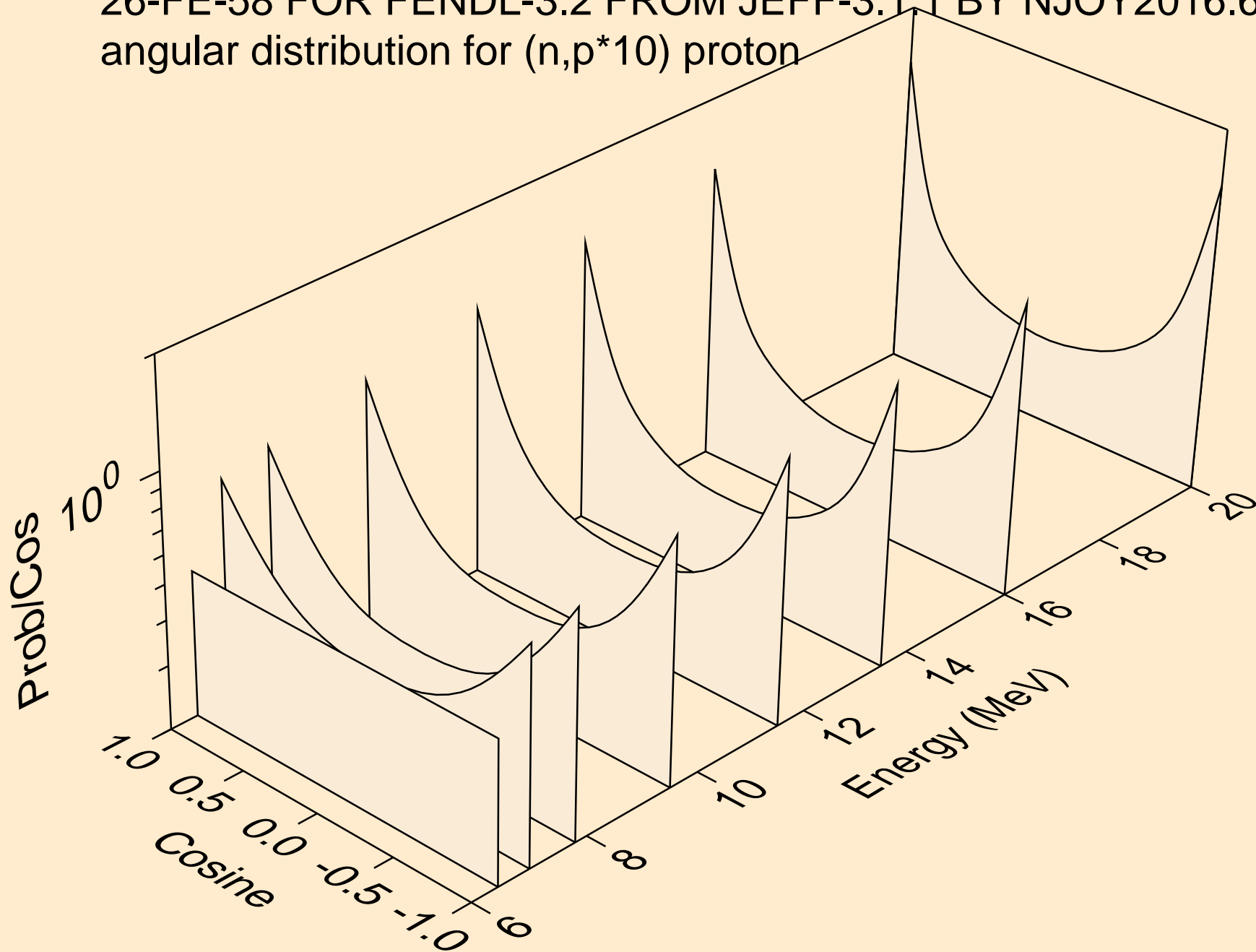

26-FE-58 FOR FENDL-3.2 FROM JEFF-3.1.1 BY NJOY2016.60+ ON
protons from (n,p*c)

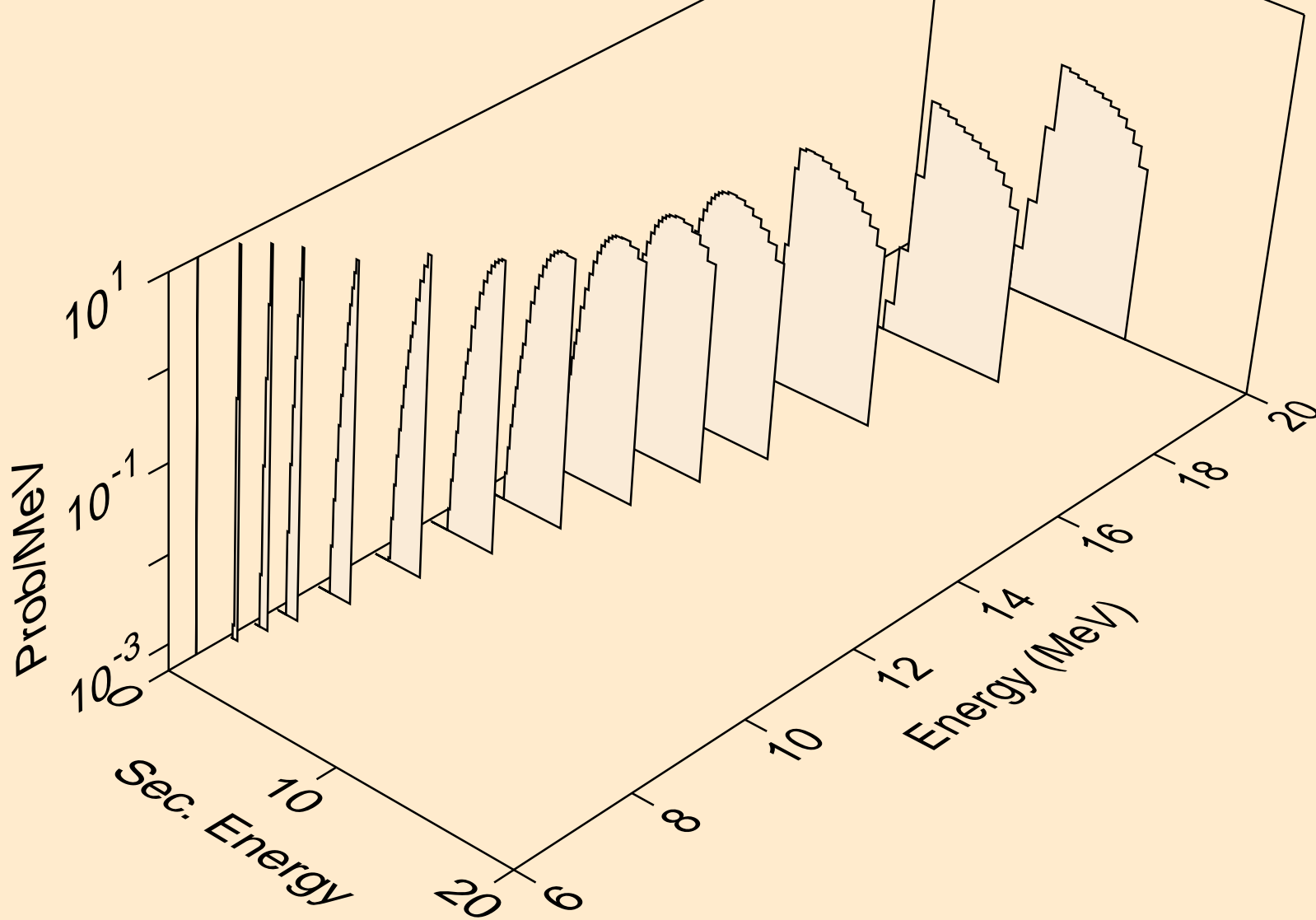

26-FE-58 FOR FENDL-3.2 FROM JEFF-3.1.1 BY NJOY2016.60+ ON
deuterons from (n,x)

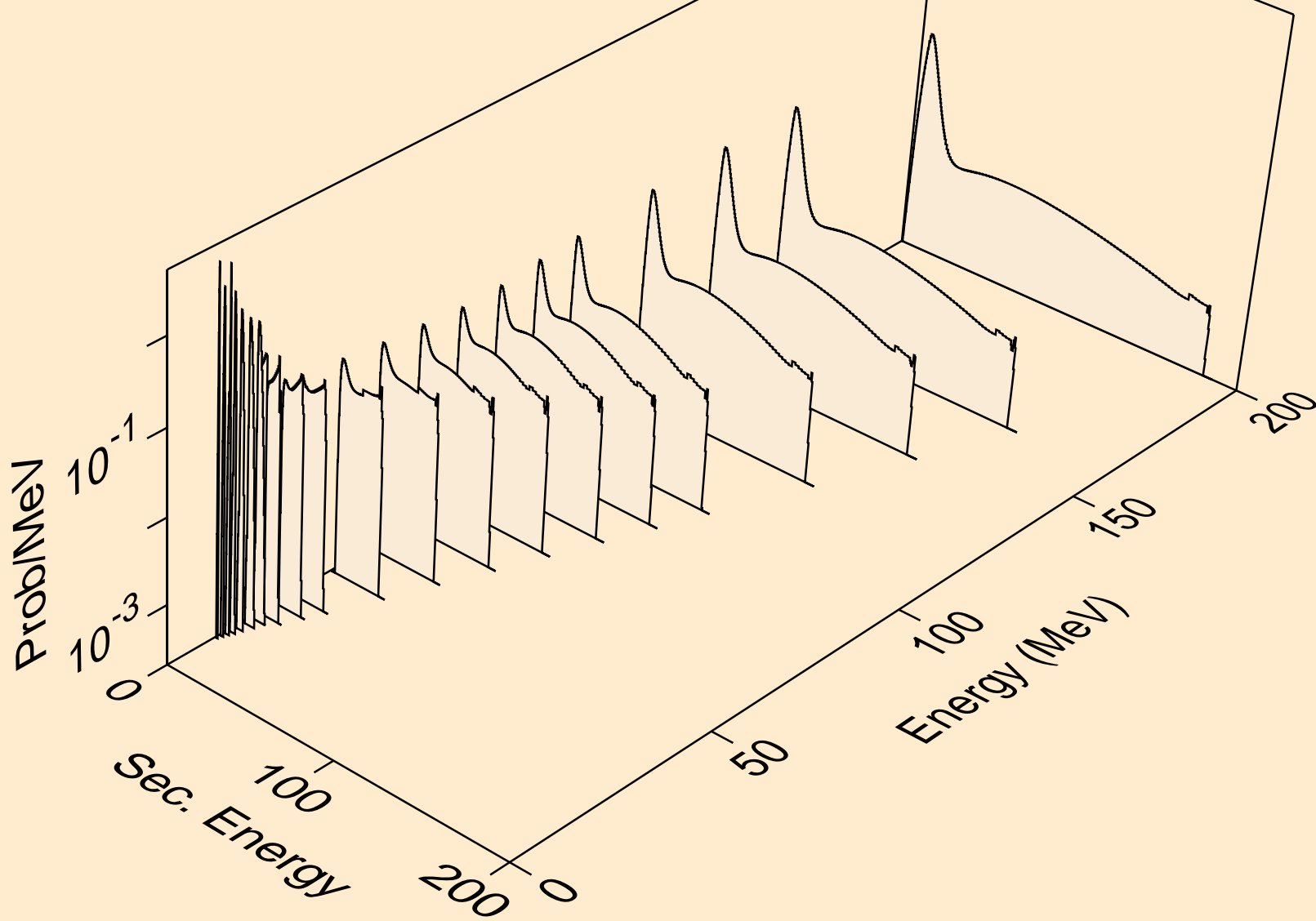

26-FE-58 FOR FENDL-3.2 FROM JEFF-3.1.1 BY NJOY2016.60+ ON
angular distribution for (n,d*0) deuteron

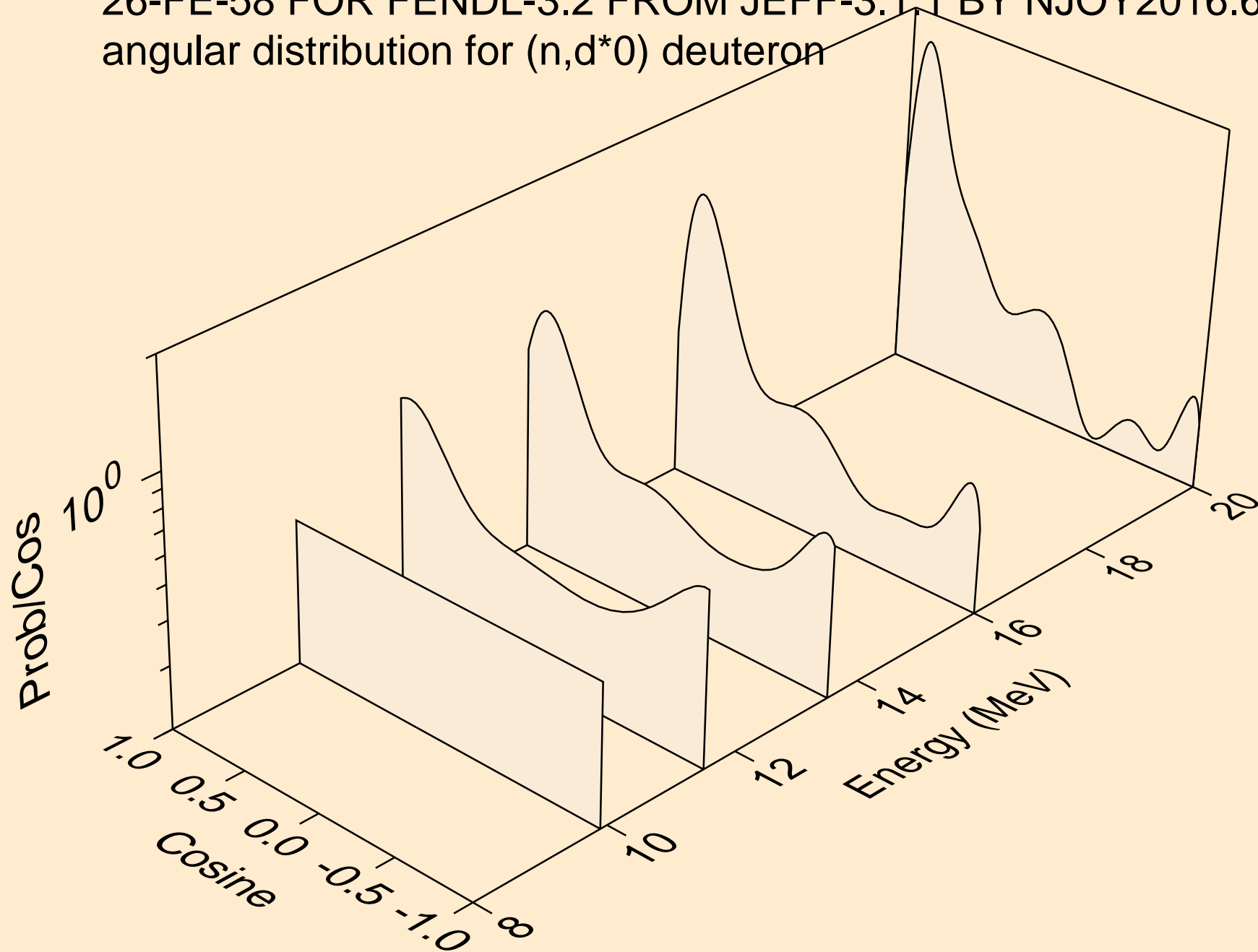

26-FE-58 FOR FENDL-3.2 FROM JEFF-3.1.1 BY NJOY2016.60+ ON
angular distribution for (n,d*1) deuteron

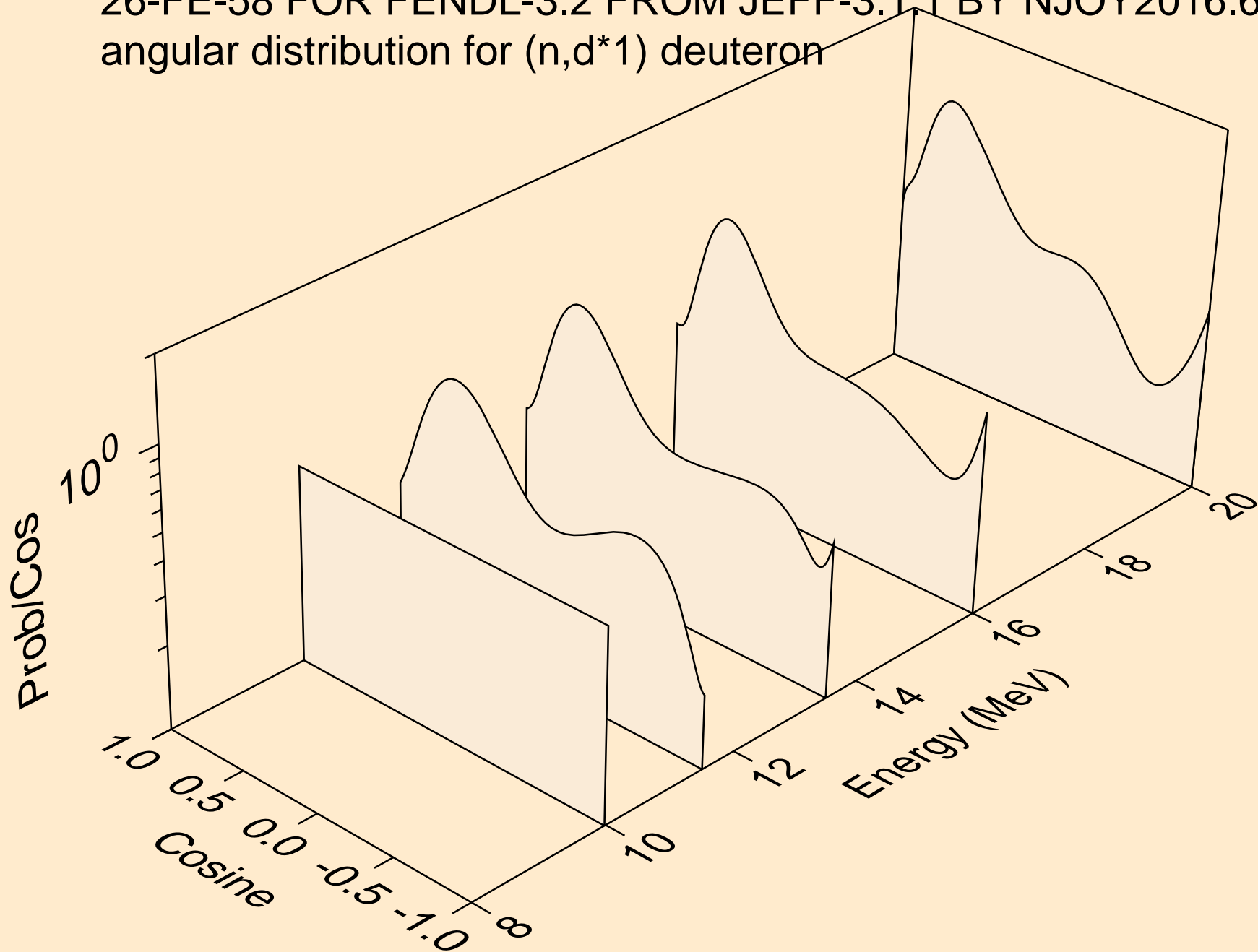

26-FE-58 FOR FENDL-3.2 FROM JEFF-3.1.1 BY NJOY2016.60+ ON
angular distribution for (n,d*2) deuteron

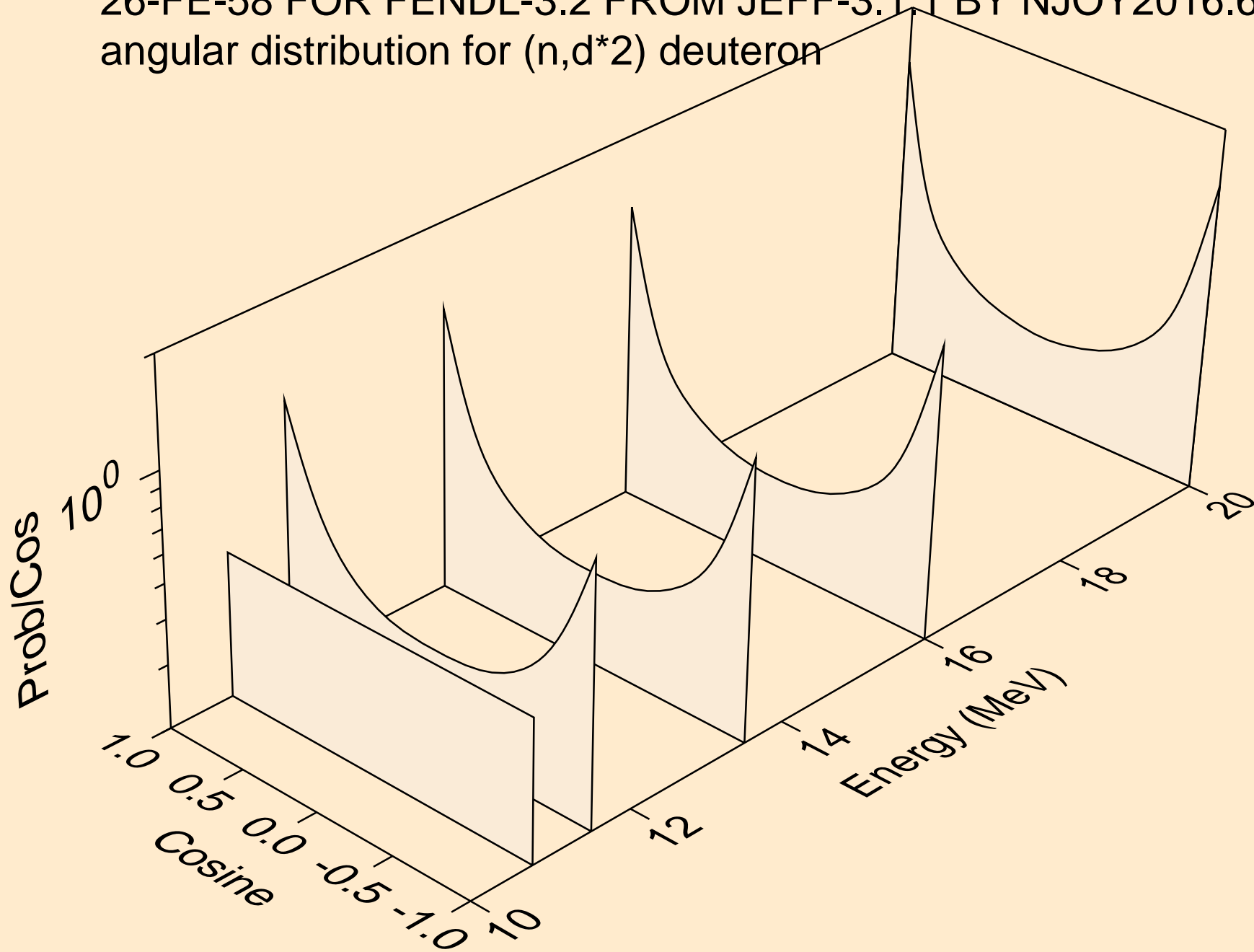

26-FE-58 FOR FENDL-3.2 FROM JEFF-3.1.1 BY NJOY2016.60+ ON
angular distribution for (n,d*3) deuteron

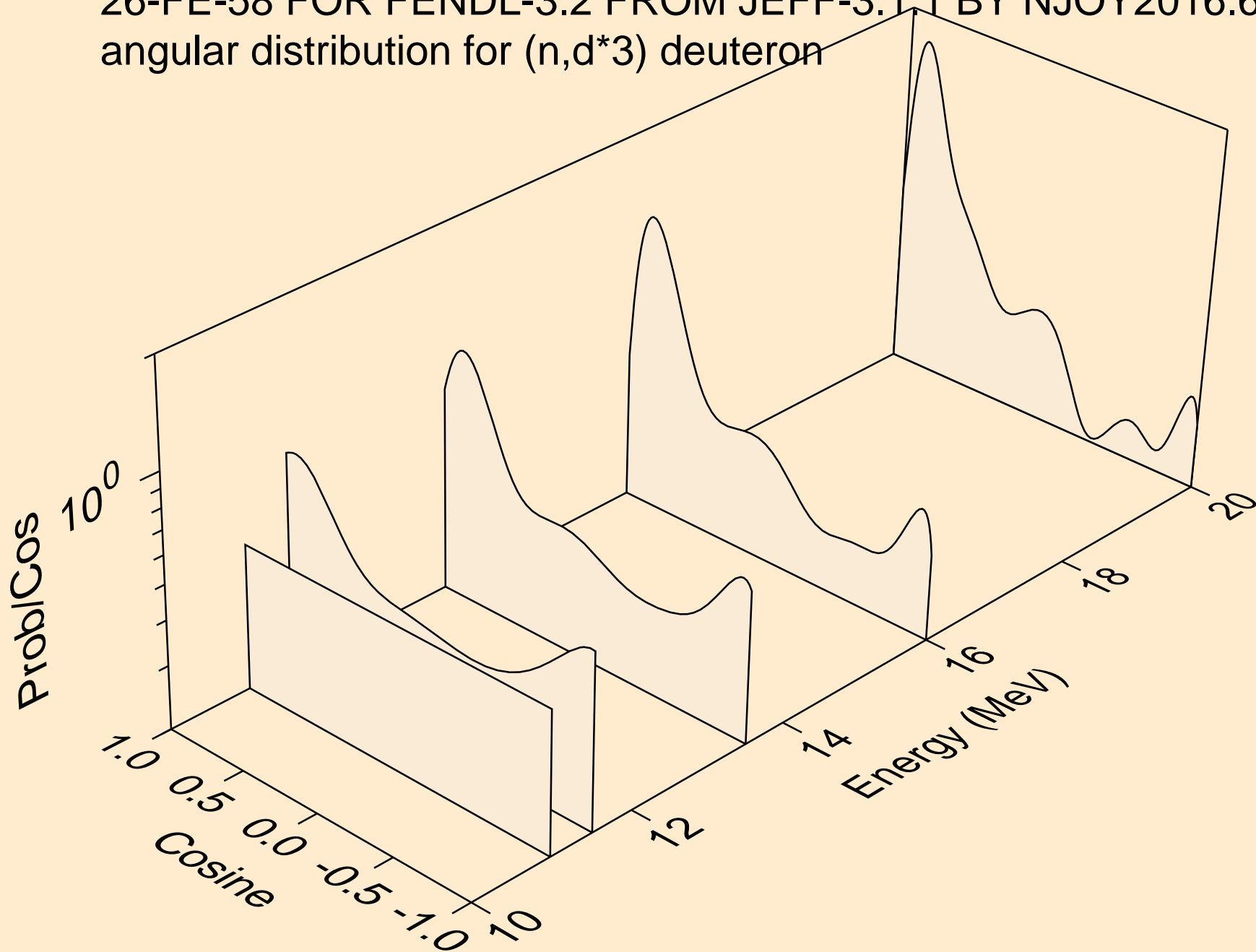

26-FE-58 FOR FENDL-3.2 FROM JEFF-3.1.1 BY NJOY2016.60+ ON
angular distribution for (n,d*4) deuteron

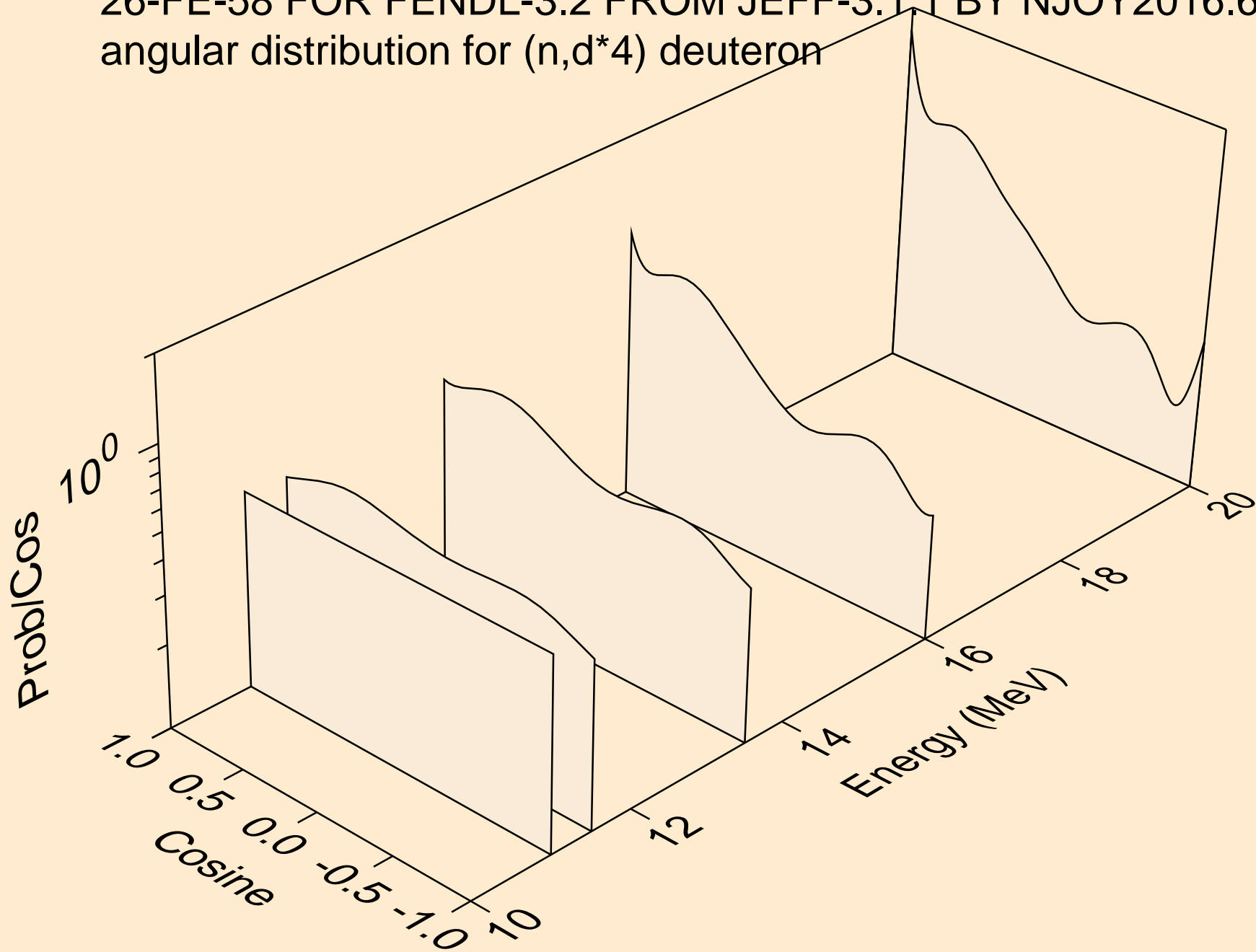

26-FE-58 FOR FENDL-3.2 FROM JEFF-3.1.1 BY NJOY2016.60+ ON
angular distribution for (n,d*5) deuteron

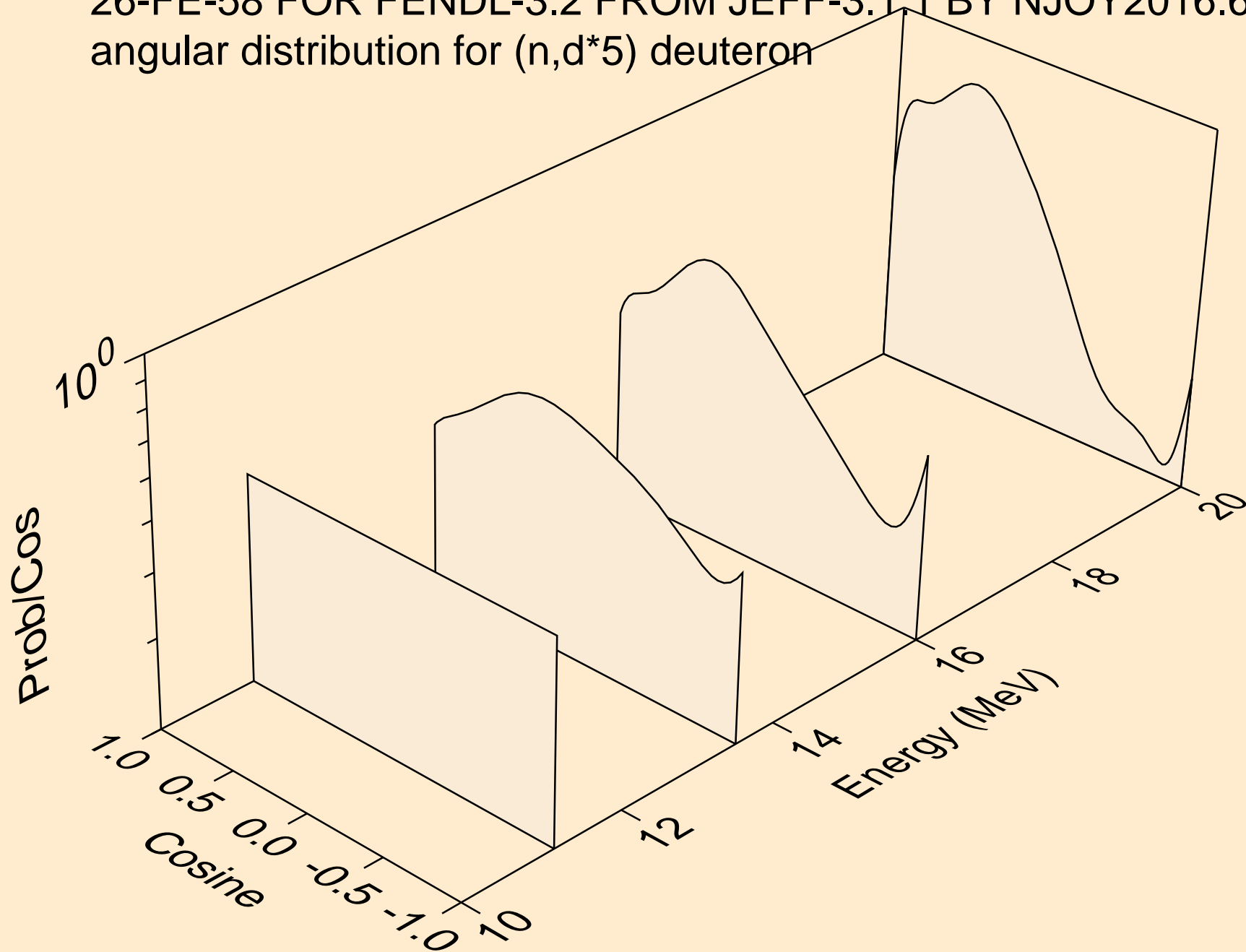

26-FE-58 FOR FENDL-3.2 FROM JEFF-3.1.1 BY NJOY2016.60+ ON
deuterons from (n,d*c)

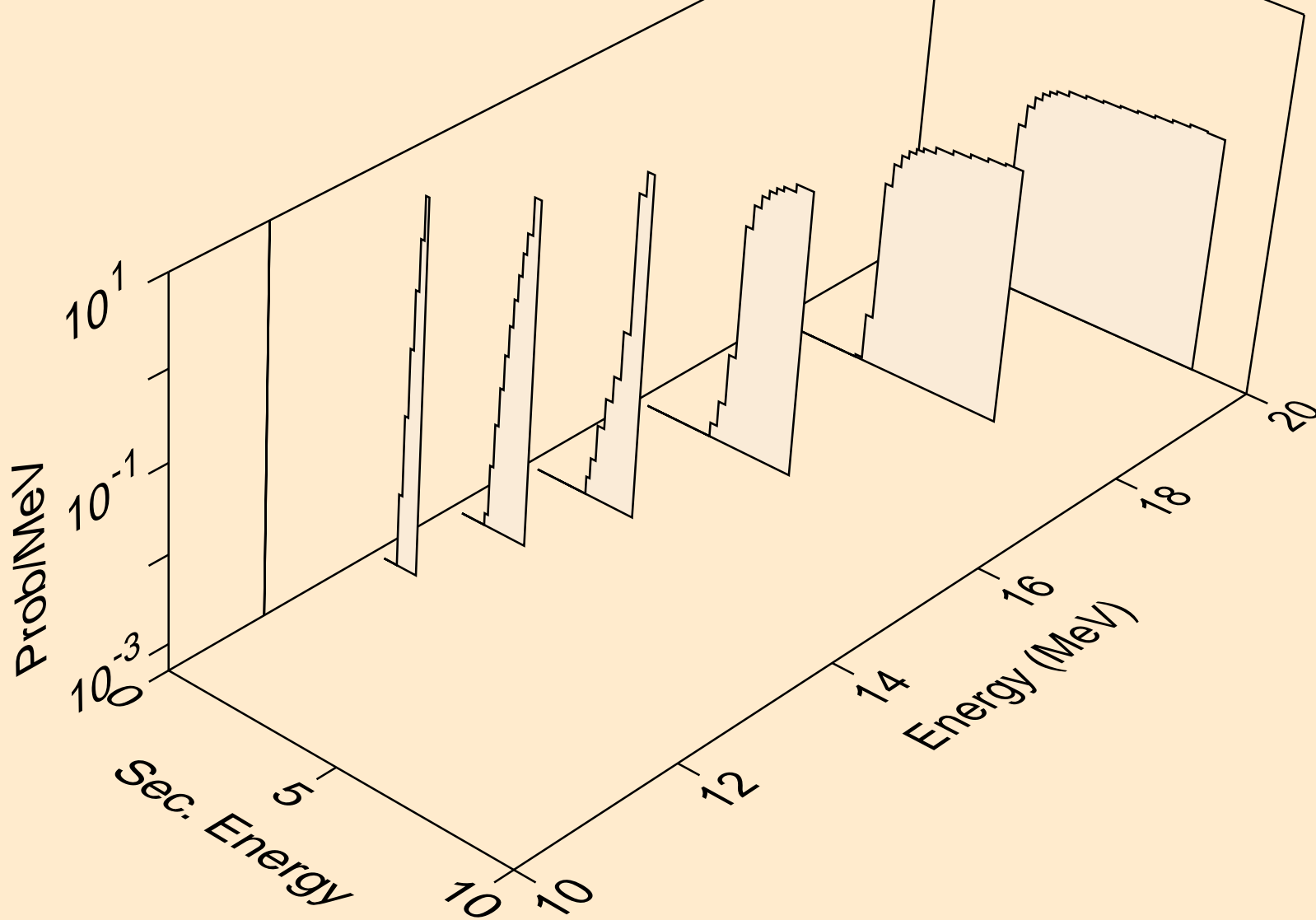

26-FE-58 FOR FENDL-3.2 FROM JEFF-3.1.1 BY NJOY2016.60+ ON
tritons from (n,x)

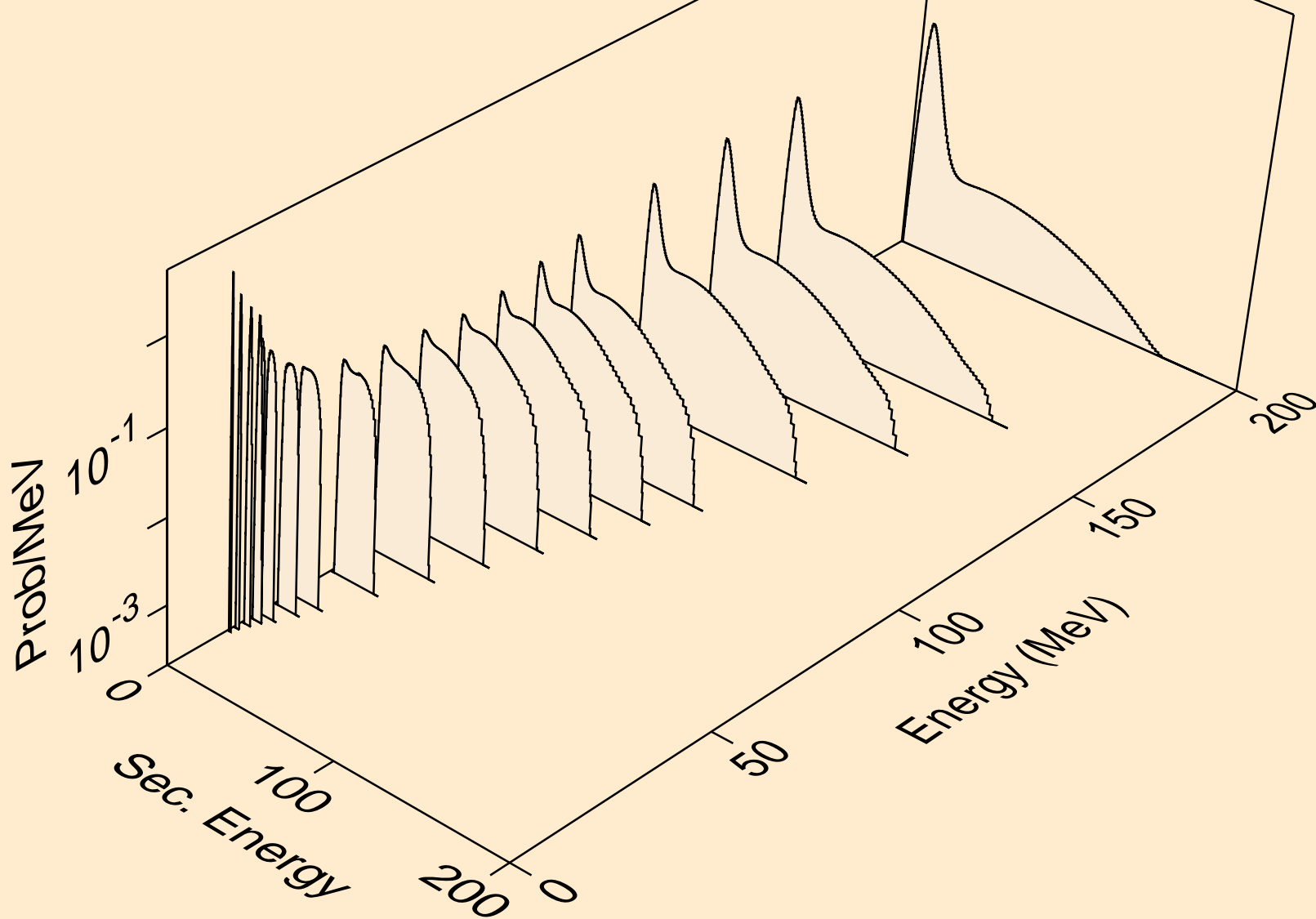

26-FE-58 FOR FENDL-3.2 FROM JEFF-3.1.1 BY NJOY2016.60+ ON
angular distribution for (n,t*0) triton

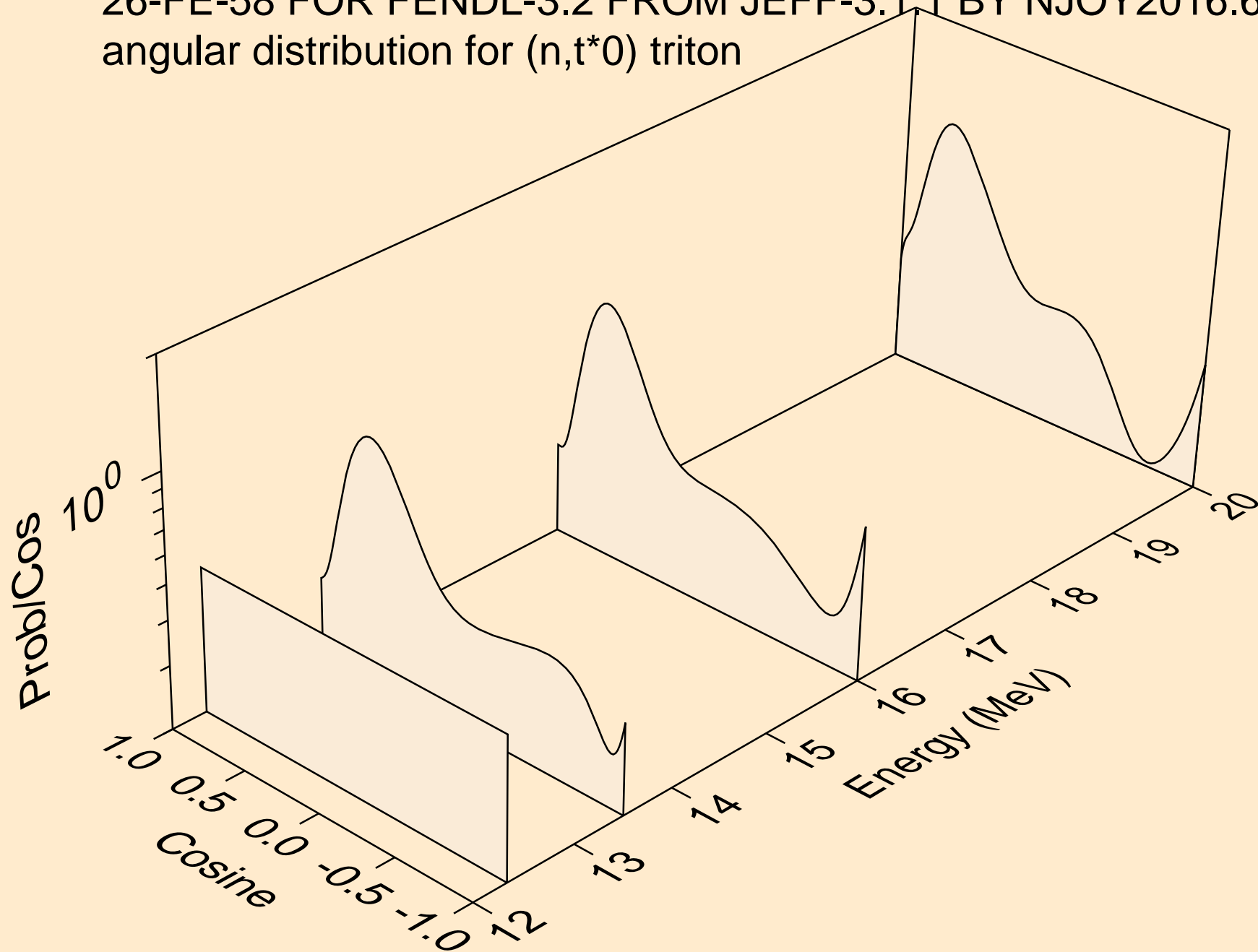

26-FE-58 FOR FENDL-3.2 FROM JEFF-3.1.1 BY NJOY2016.60+ ON
angular distribution for (n,t*1) triton

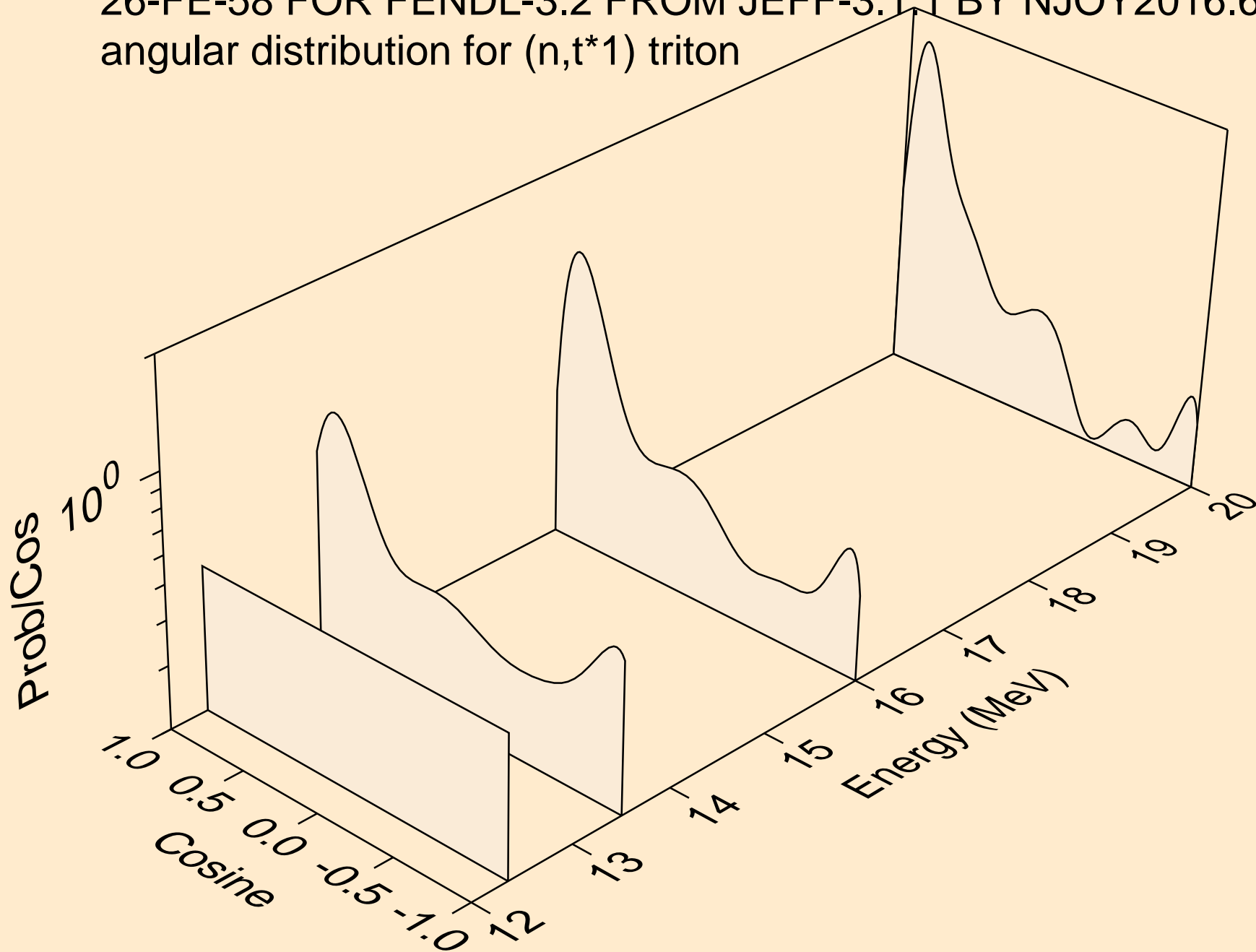

26-FE-58 FOR FENDL-3.2 FROM JEFF-3.1.1 BY NJOY2016.60+ ON
angular distribution for (n,t*2) triton

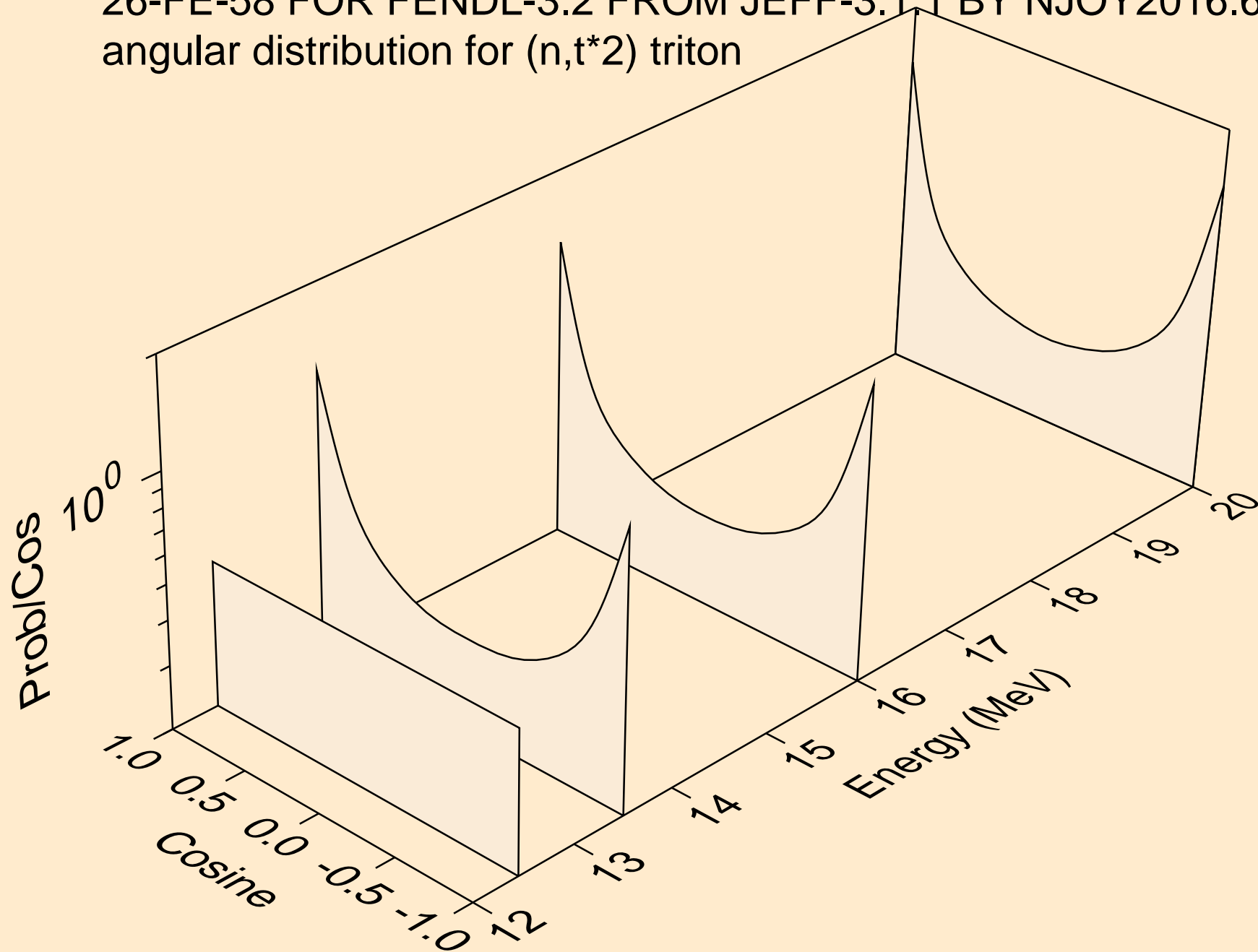

26-FE-58 FOR FENDL-3.2 FROM JEFF-3.1.1 BY NJOY2016.60+ ON
angular distribution for (n,t*3) triton

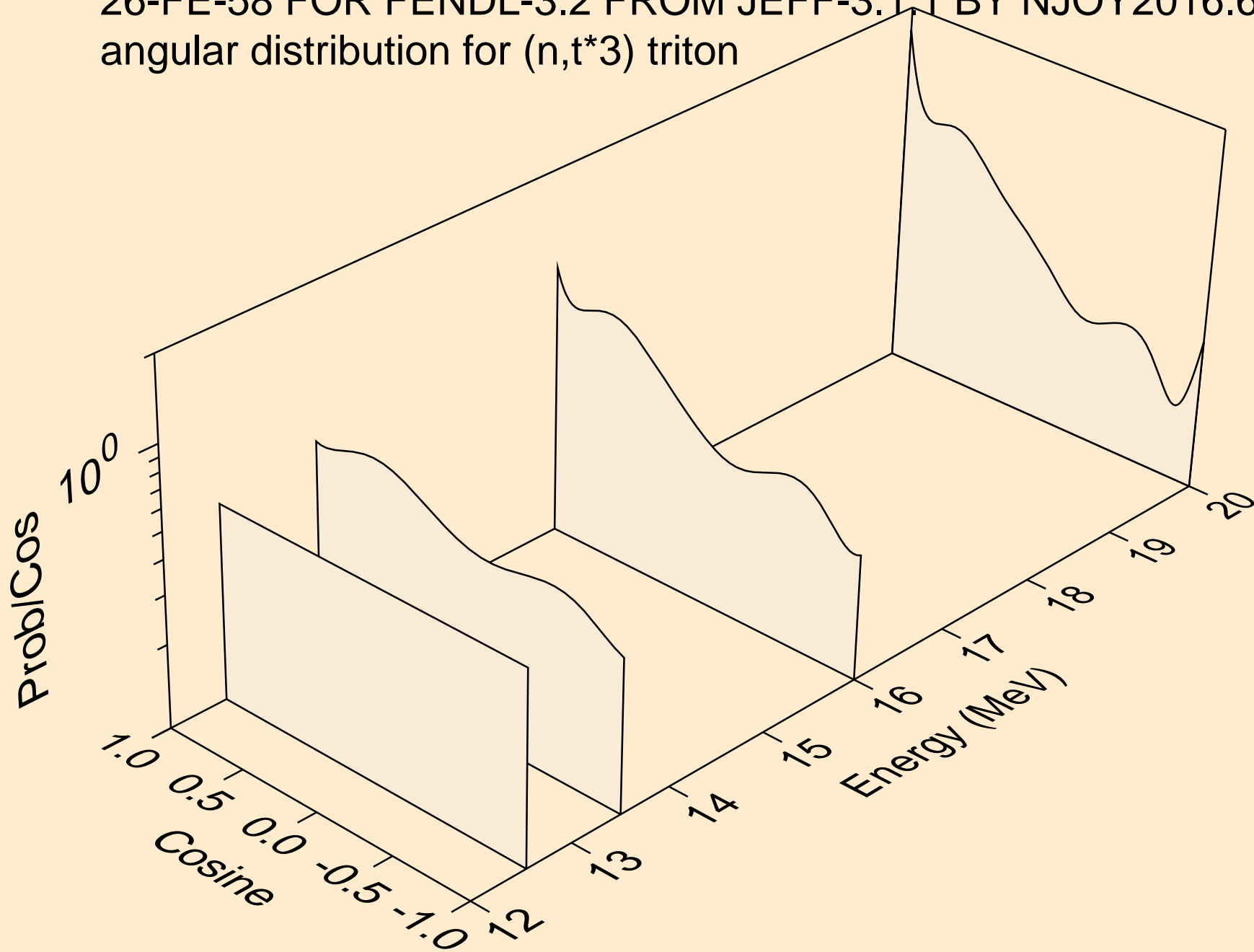

26-FE-58 FOR FENDL-3.2 FROM JEFF-3.1.1 BY NJOY2016.60+ ON
angular distribution for (n,t*4) triton

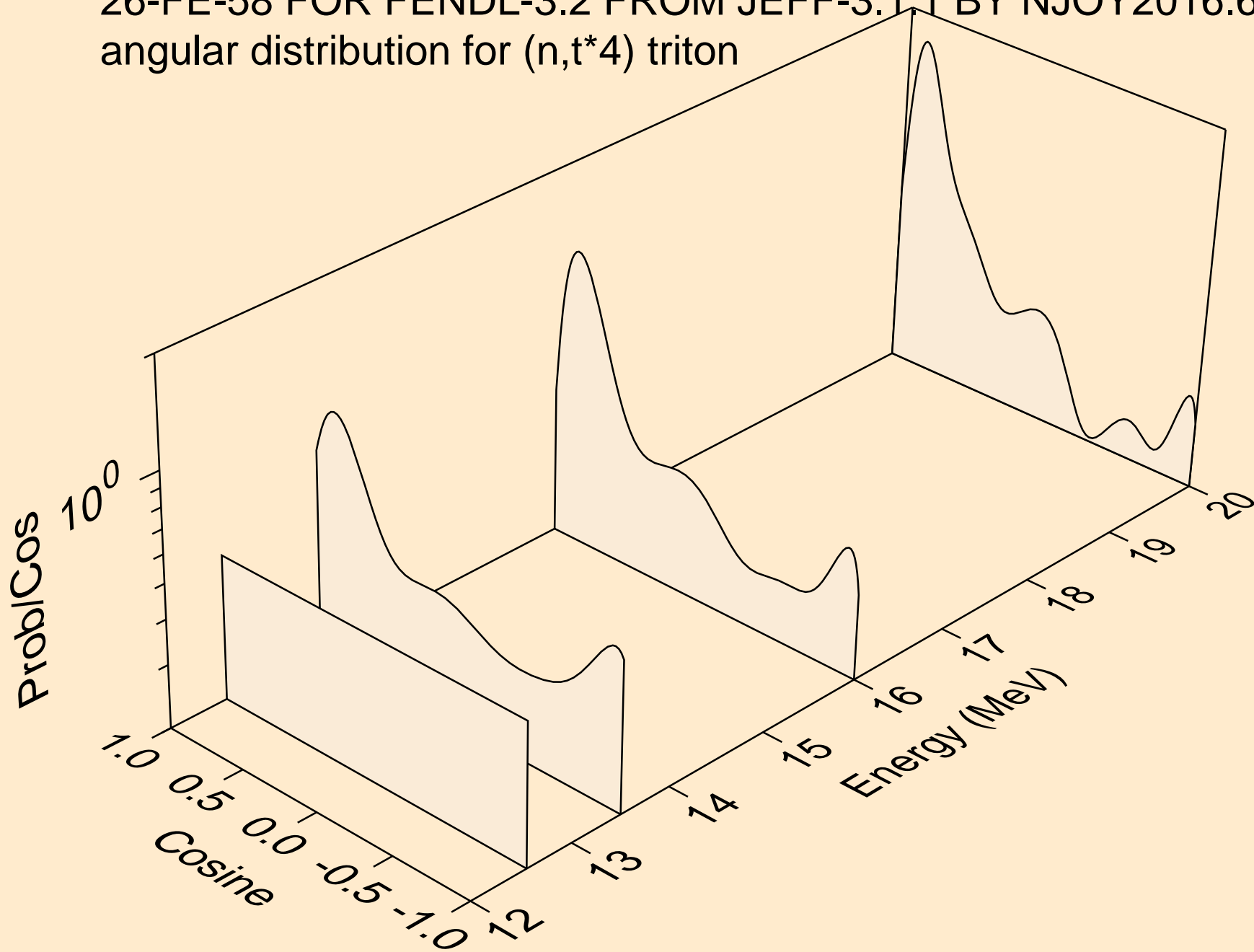

26-FE-58 FOR FENDL-3.2 FROM JEFF-3.1.1 BY NJOY2016.60+ ON
angular distribution for (n,t*5) triton

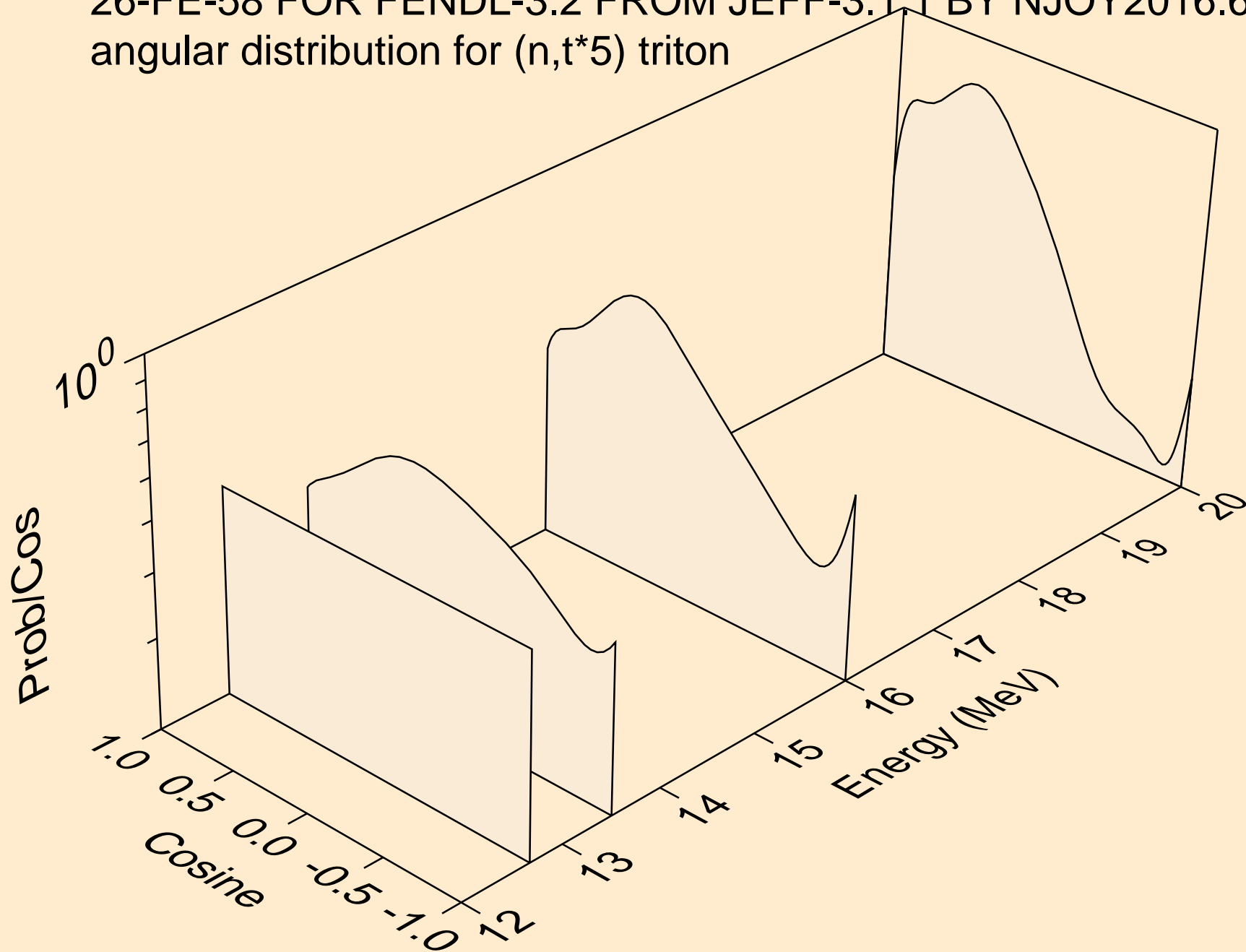

26-FE-58 FOR FENDL-3.2 FROM JEFF-3.1.1 BY NJOY2016.60+ ON
tritons from (n,t*c)

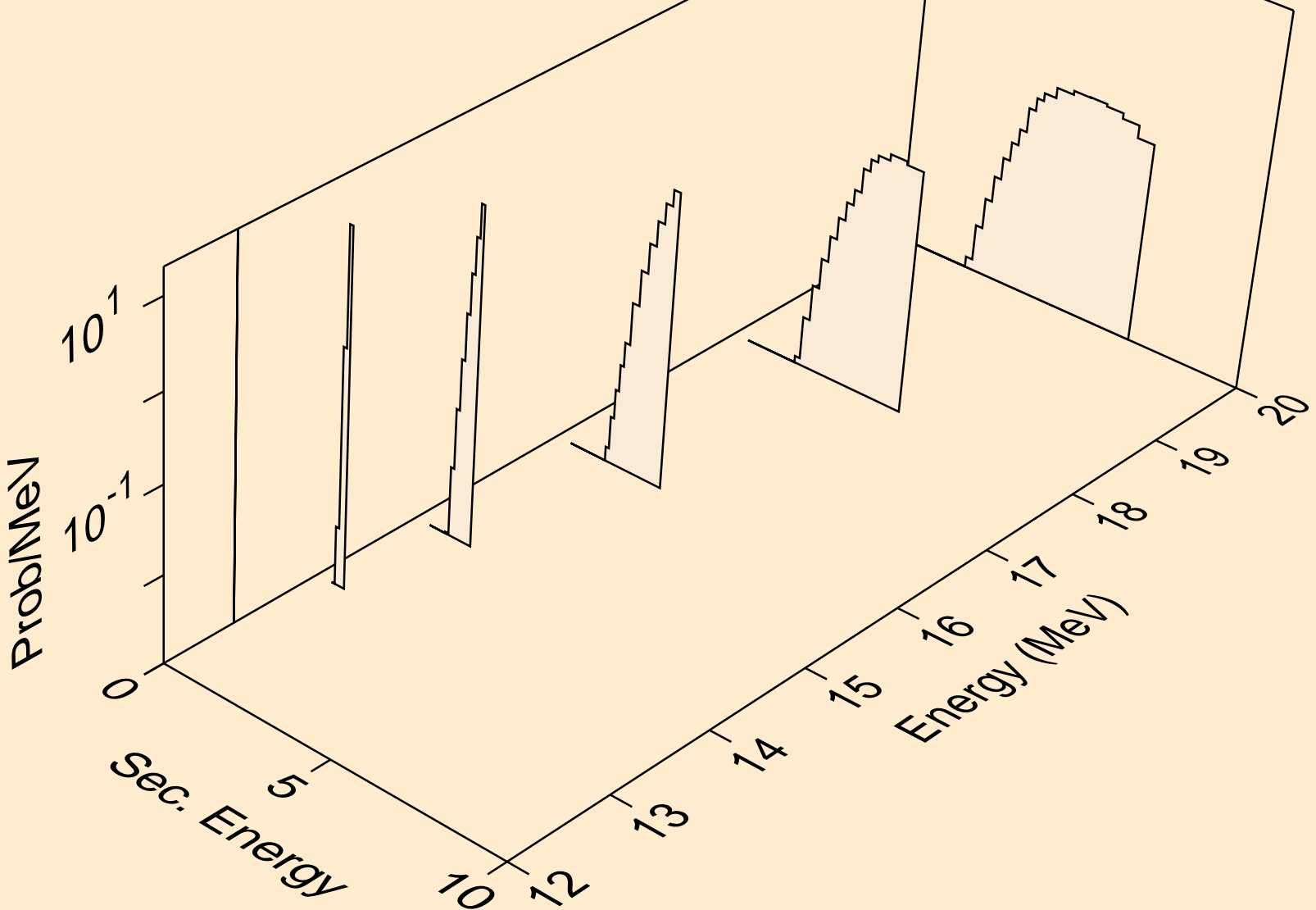

26-FE-58 FOR FENDL-3.2 FROM JEFF-3.1.1 BY NJOY2016.60+ ON
he3s from (n,x)

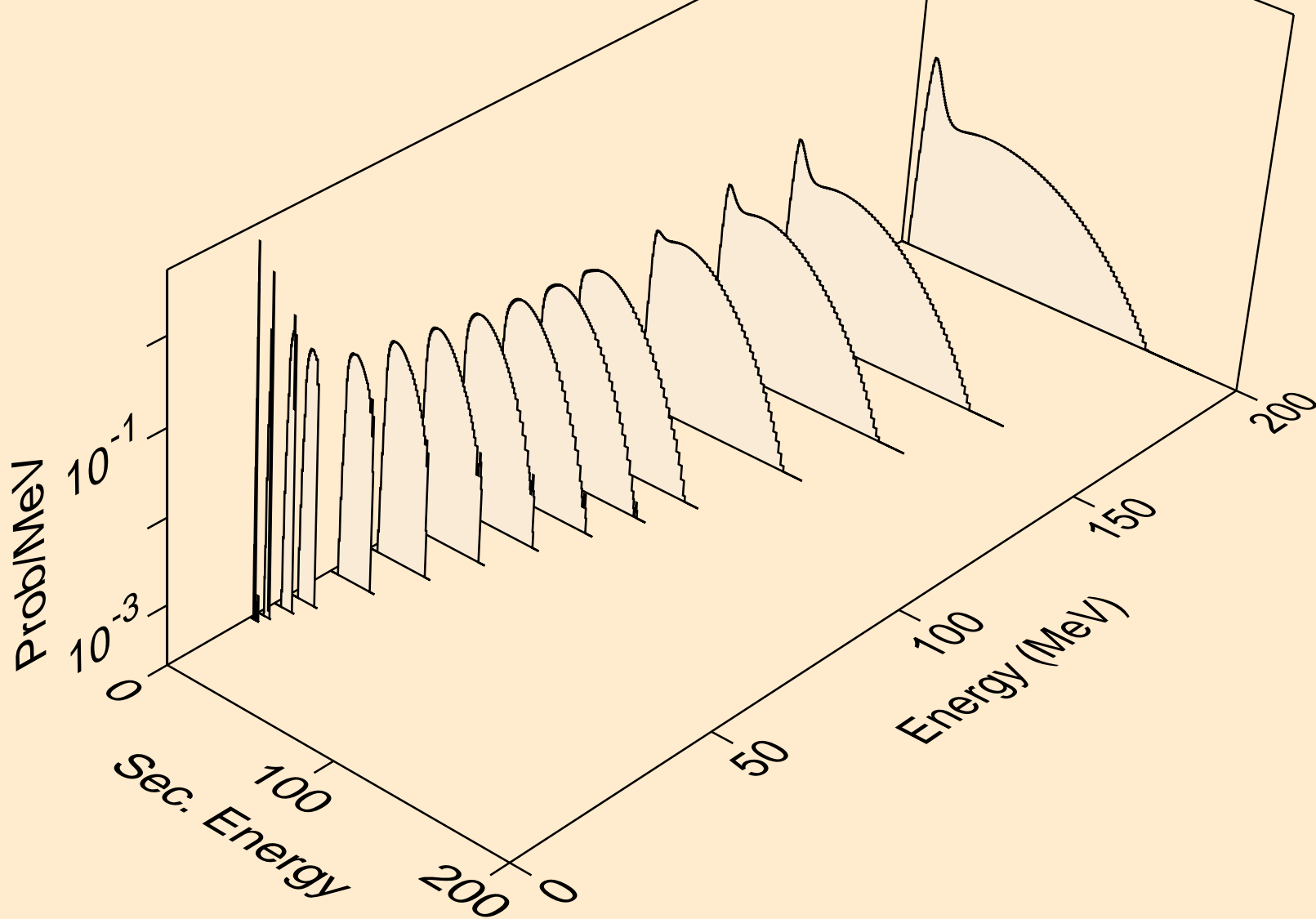

26-FE-58 FOR FENDL-3.2 FROM JEFF-3.1.1 BY NJOY2016.60+ ON
angular distribution for (n,he3*0) 3he

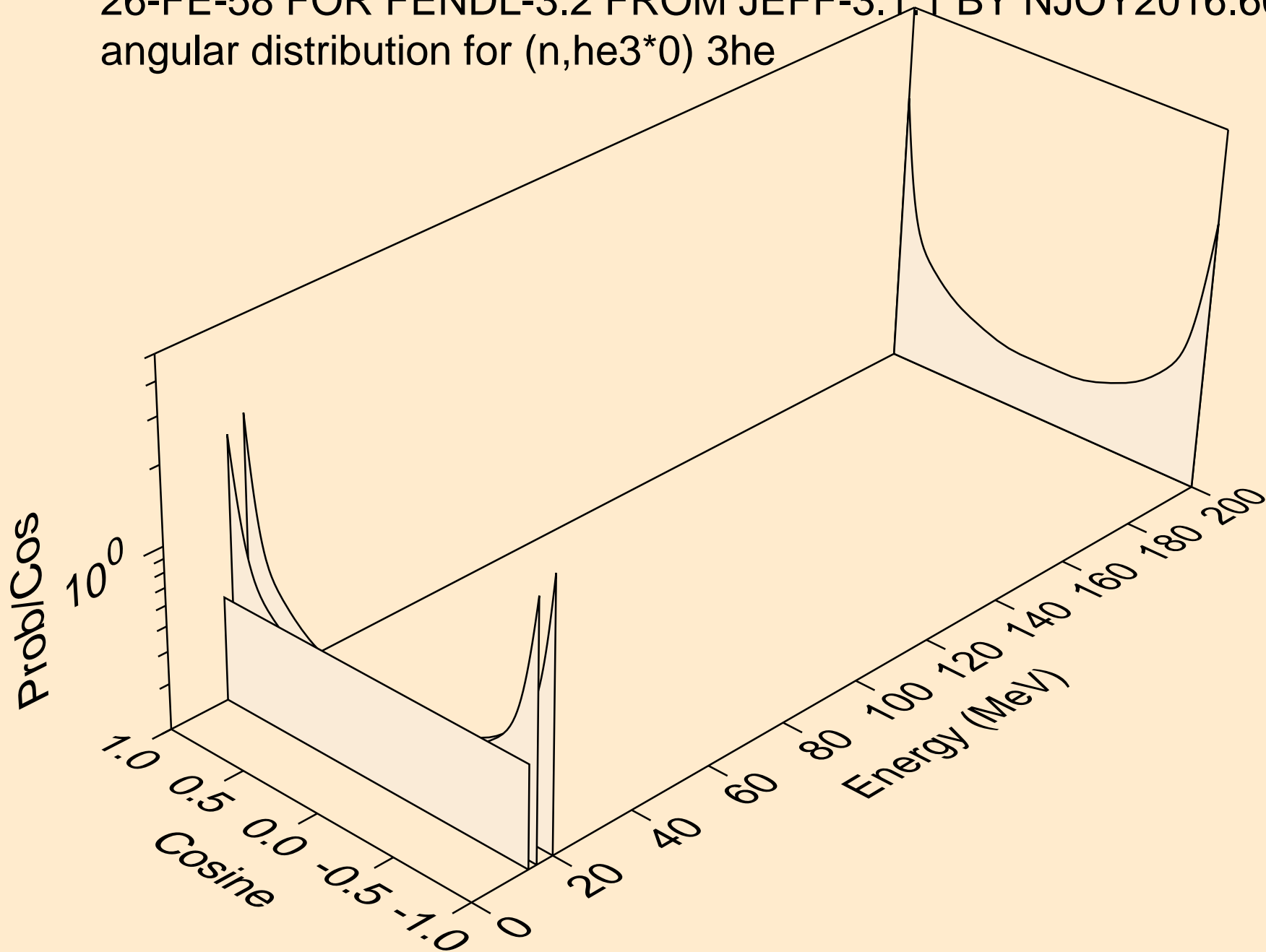

26-FE-58 FOR FENDL-3.2 FROM JEFF-3.1.1 BY NJOY2016.60+ ON
angular distribution for (n,he3*1) 3he

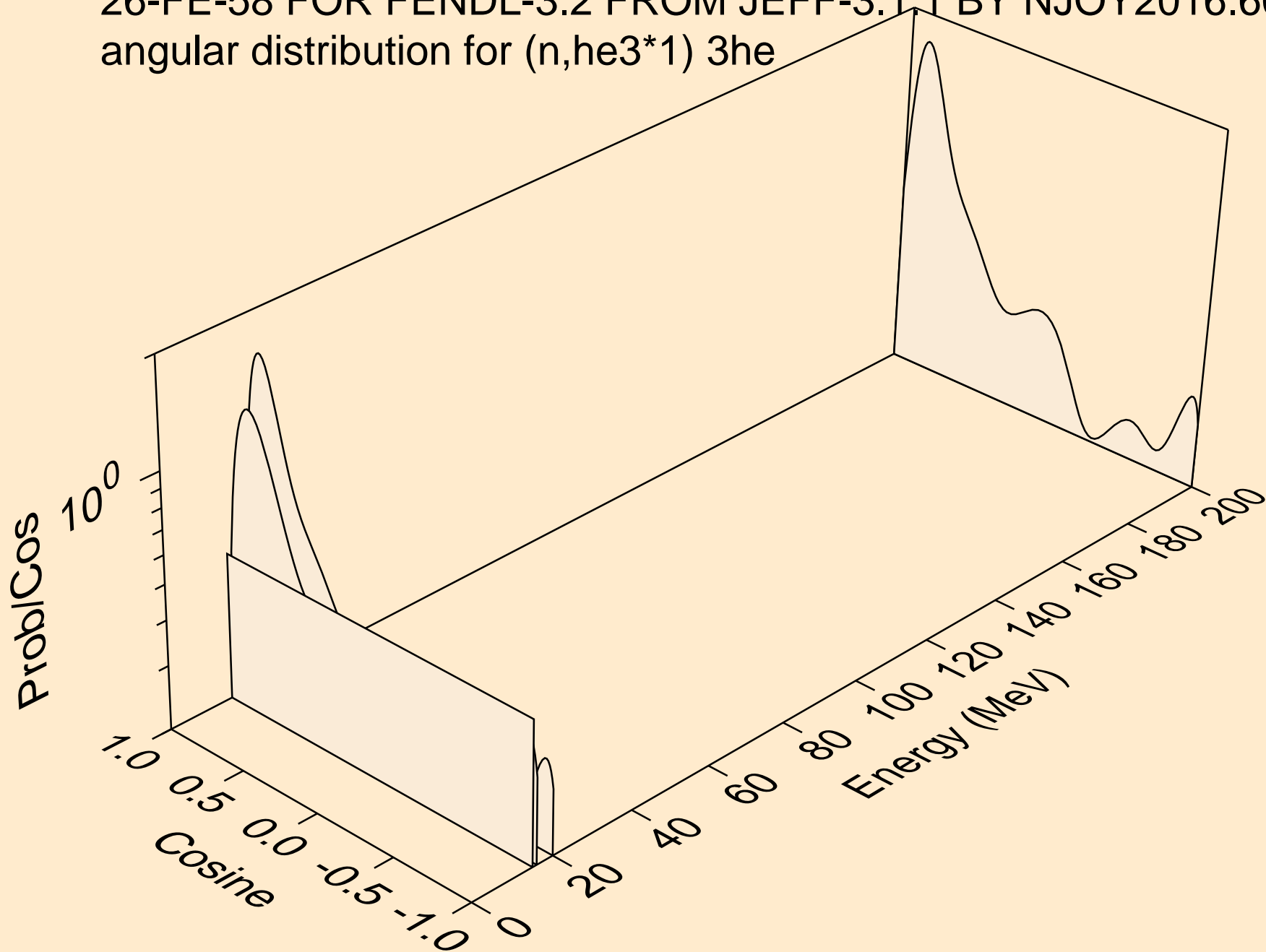

26-FE-58 FOR FENDL-3.2 FROM JEFF-3.1.1 BY NJOY2016.60+ ON
angular distribution for (n,he3*2) 3he

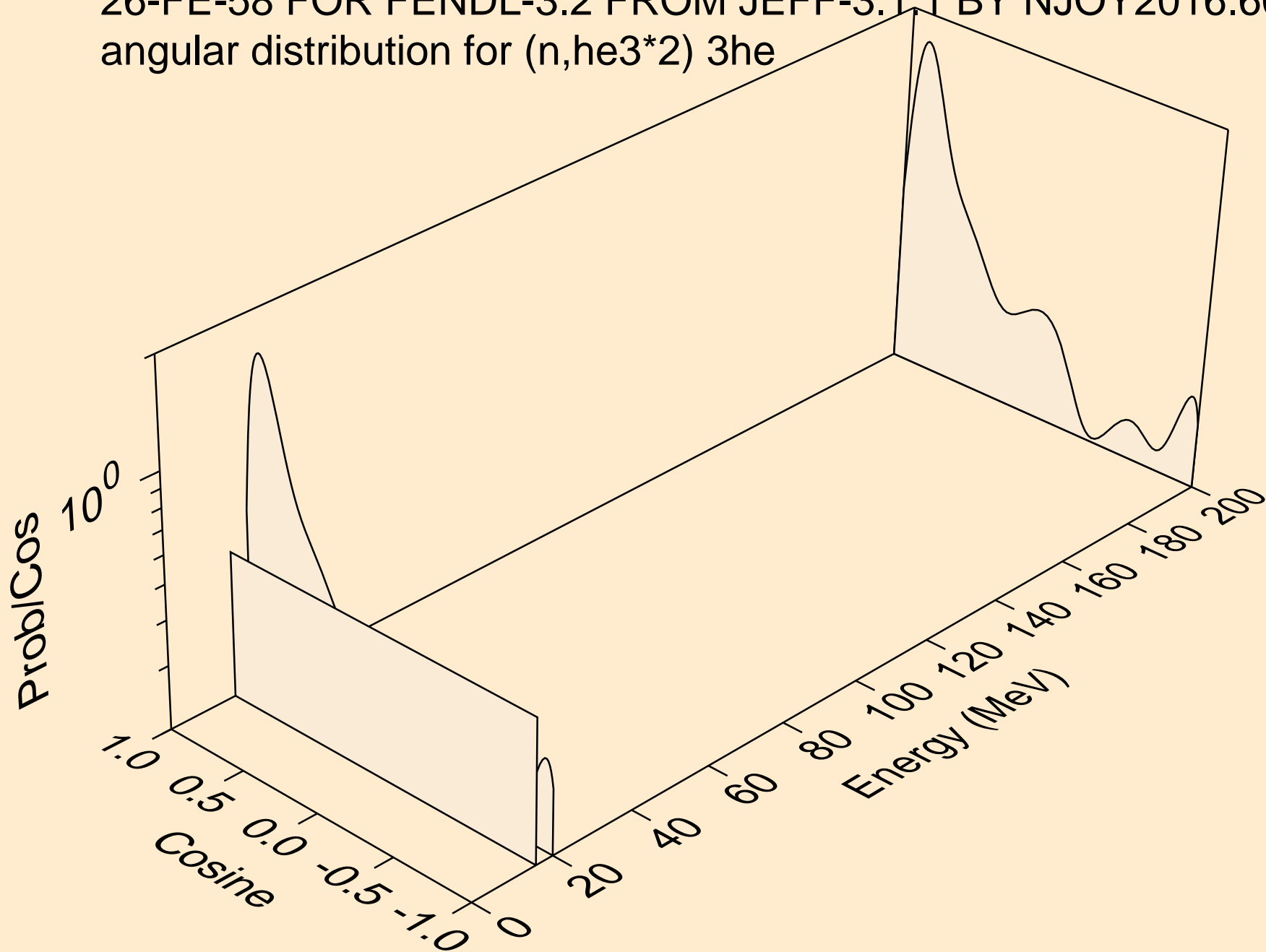

26-FE-58 FOR FENDL-3.2 FROM JEFF-3.1.1 BY NJOY2016.60+ ON
alphas from (n,x)

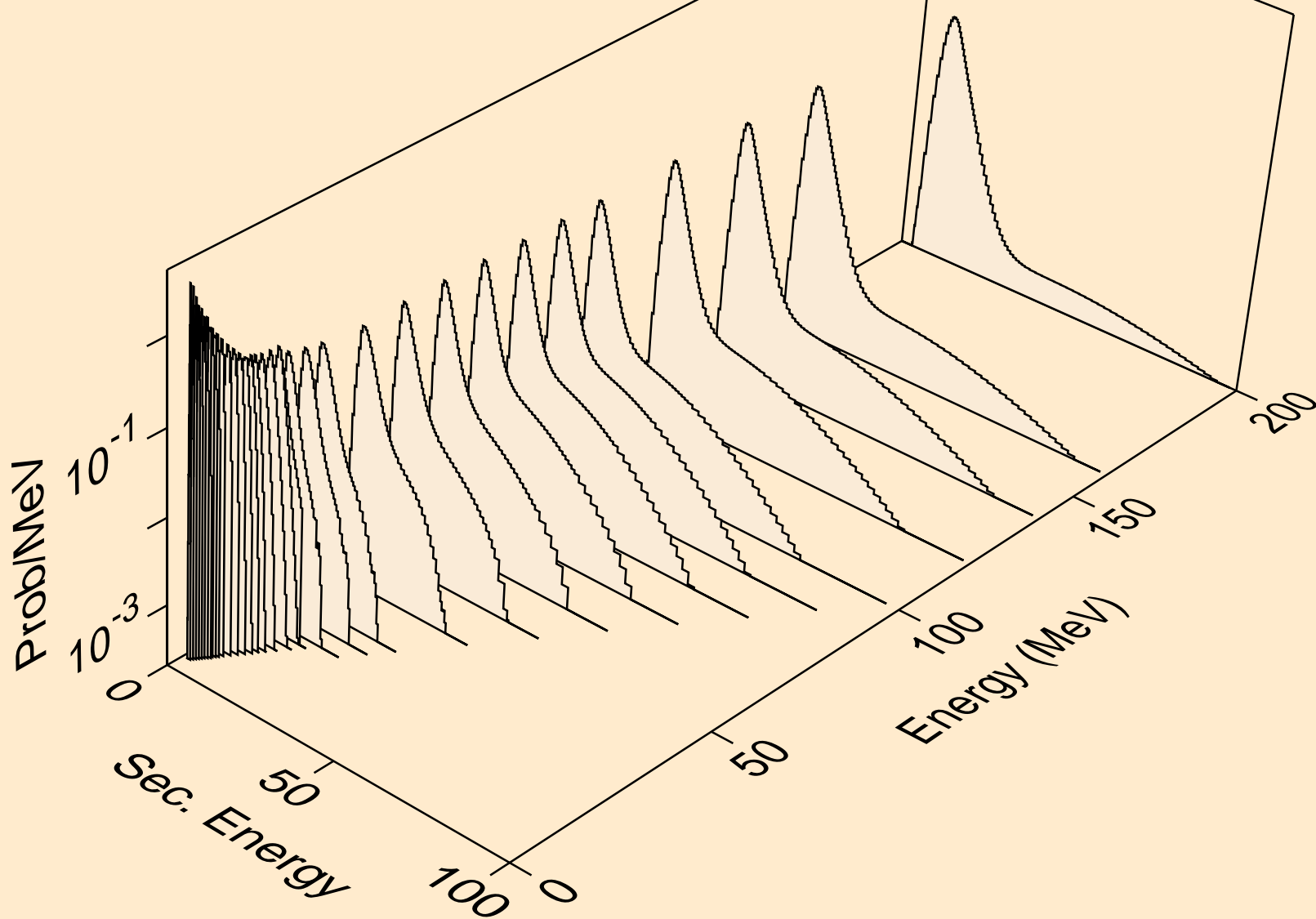

26-FE-58 FOR FENDL-3.2 FROM JEFF-3.1.1 BY NJOY2016.60+ ON
alphas from (n,n*)a

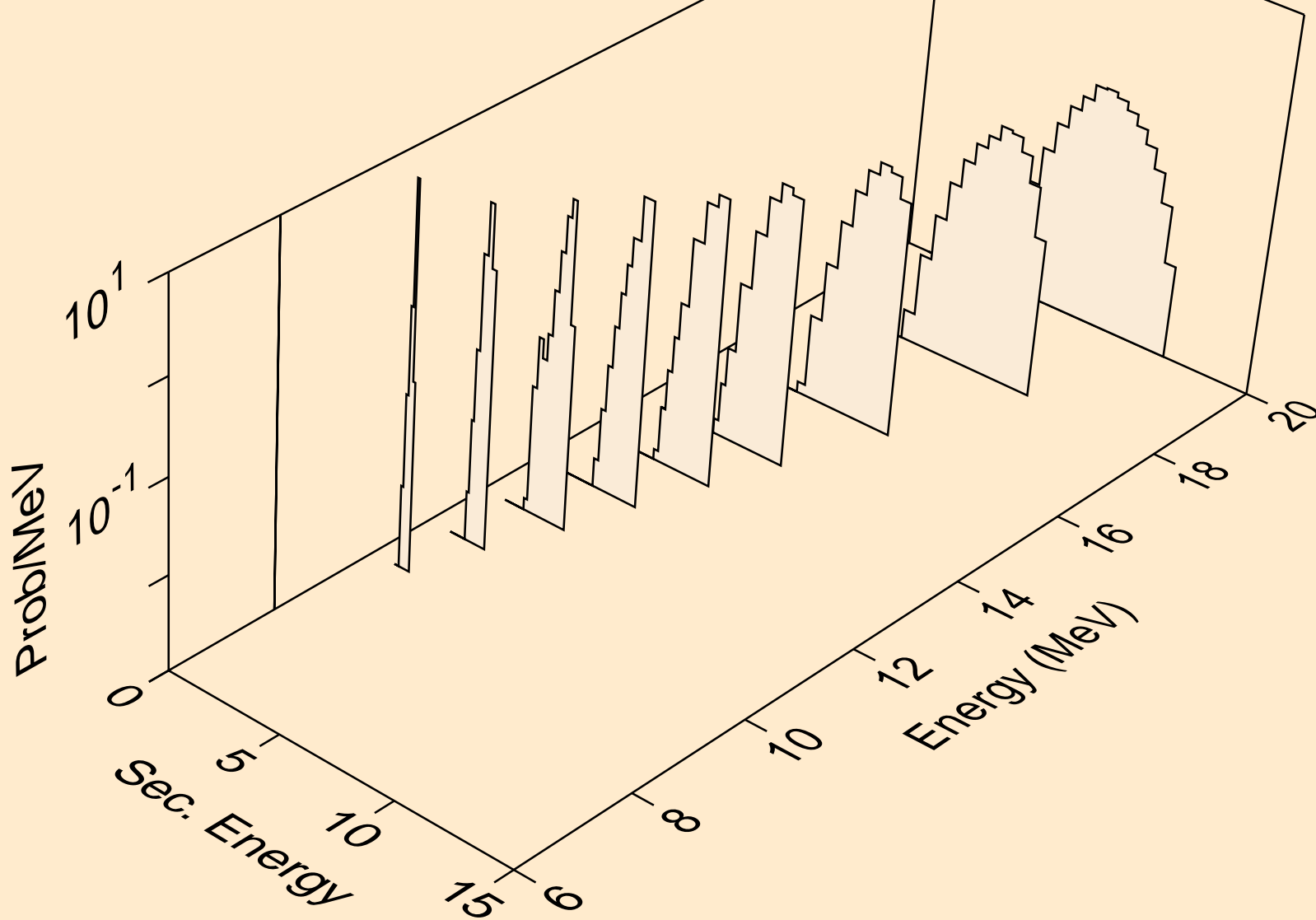

26-FE-58 FOR FENDL-3.2 FROM JEFF-3.1.1 BY NJOY2016.60+ ON
alphas from (n,2a)

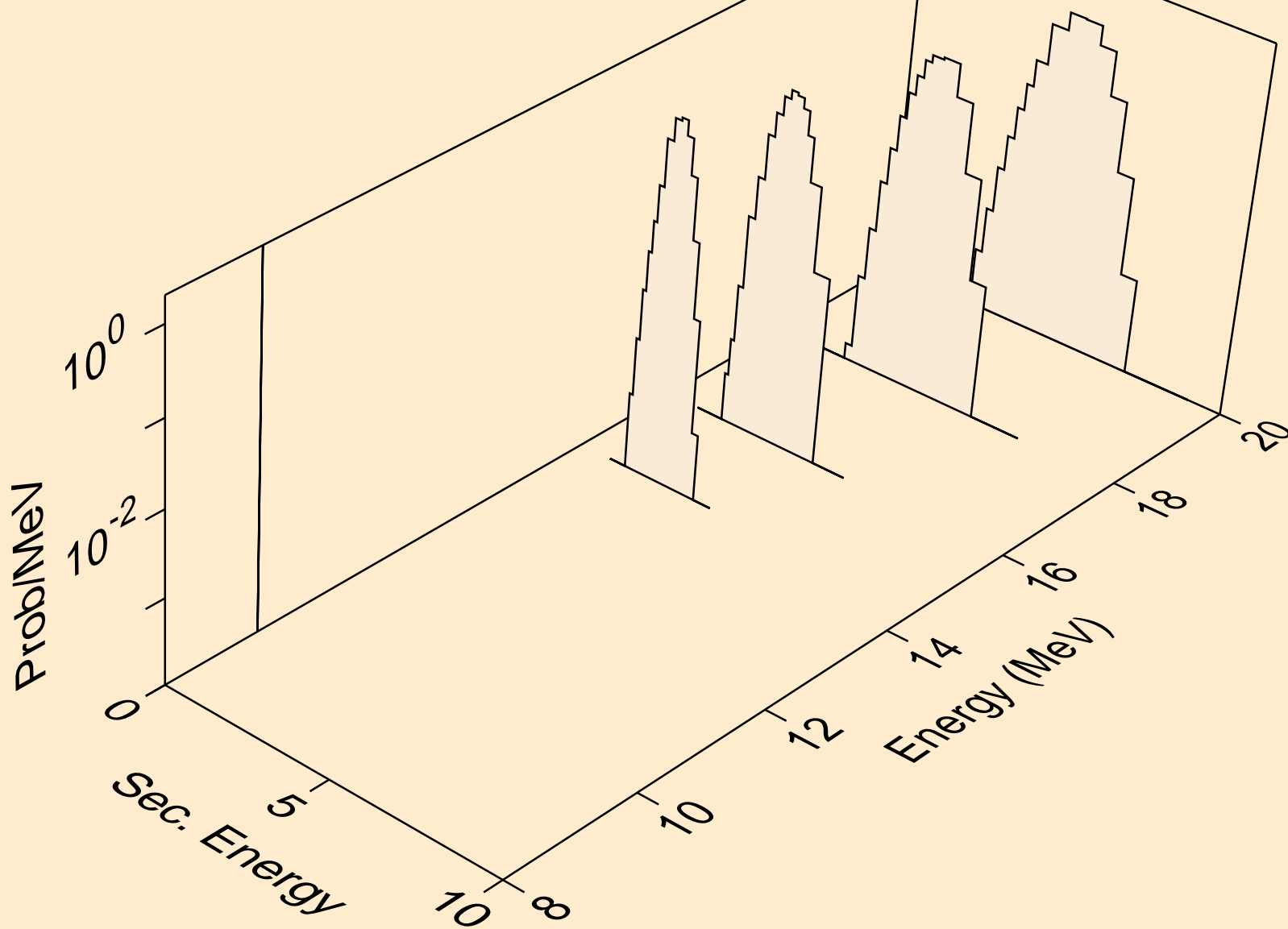

26-FE-58 FOR FENDL-3.2 FROM JEFF-3.1.1 BY NJOY2016.60+ ON
angular distribution for (n,a*0) alpha

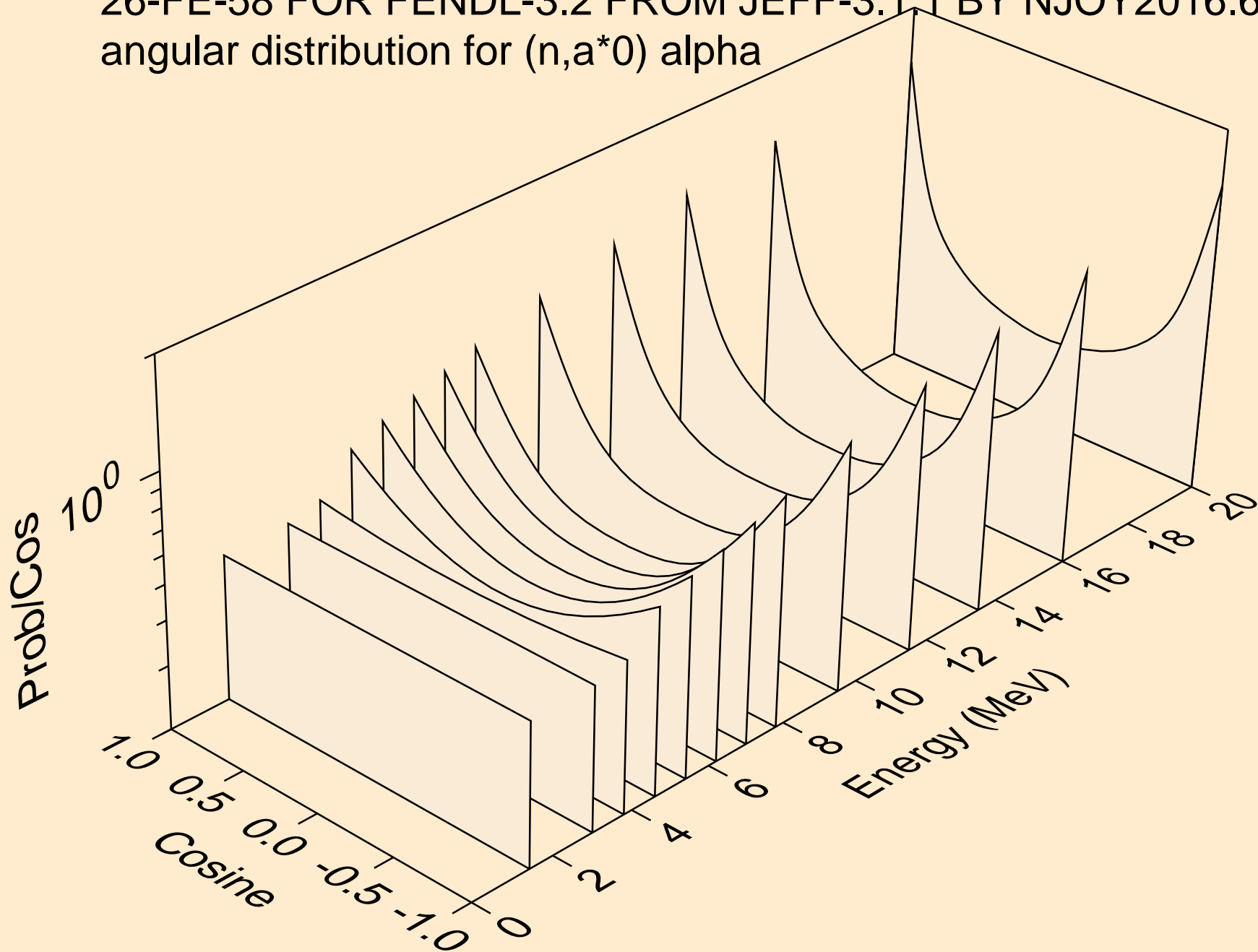

26-FE-58 FOR FENDL-3.2 FROM JEFF-3.1.1 BY NJOY2016.60+ ON
angular distribution for (n,a*1) alpha

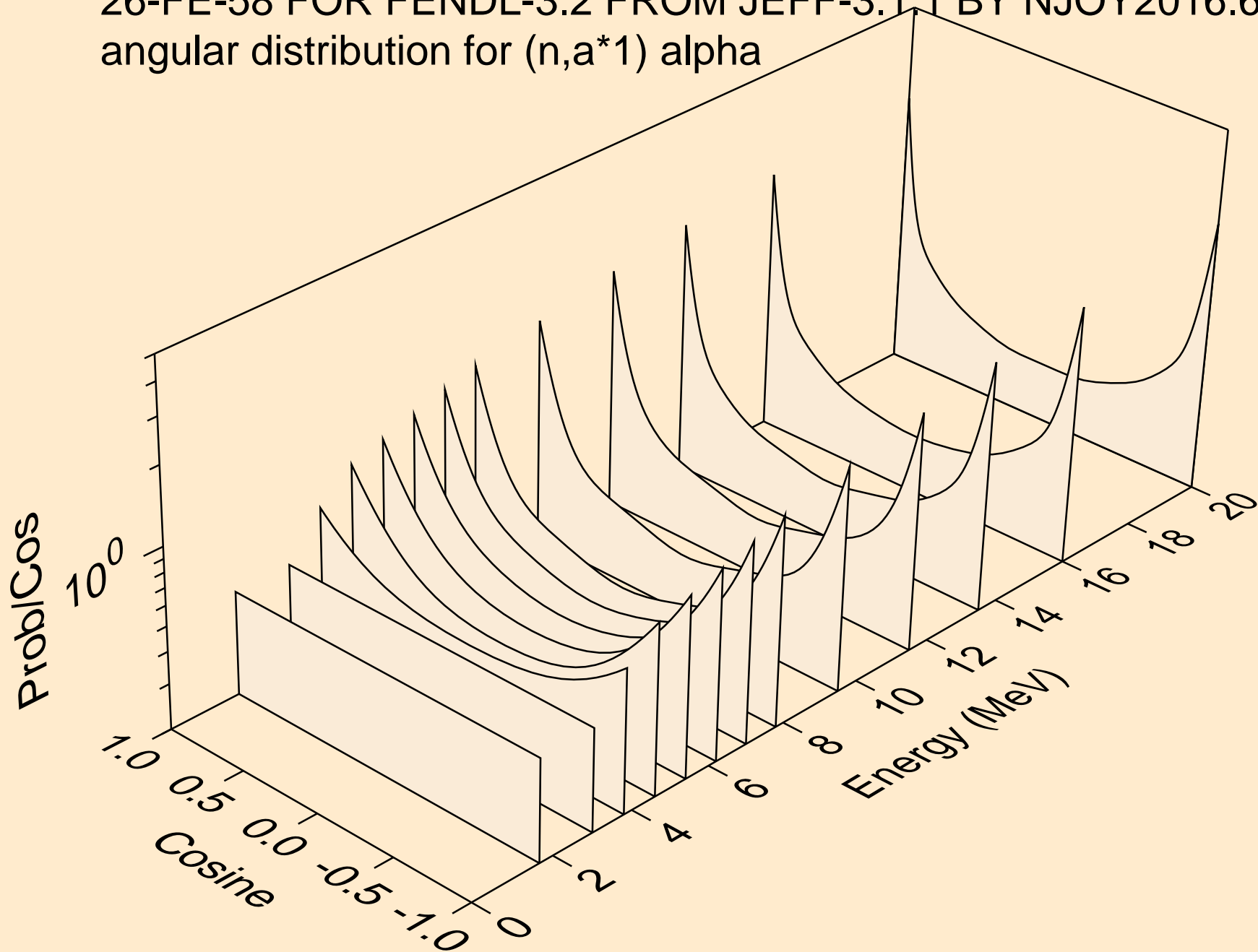

26-FE-58 FOR FENDL-3.2 FROM JEFF-3.1.1 BY NJOY2016.60+ ON
angular distribution for (n,a*2) alpha

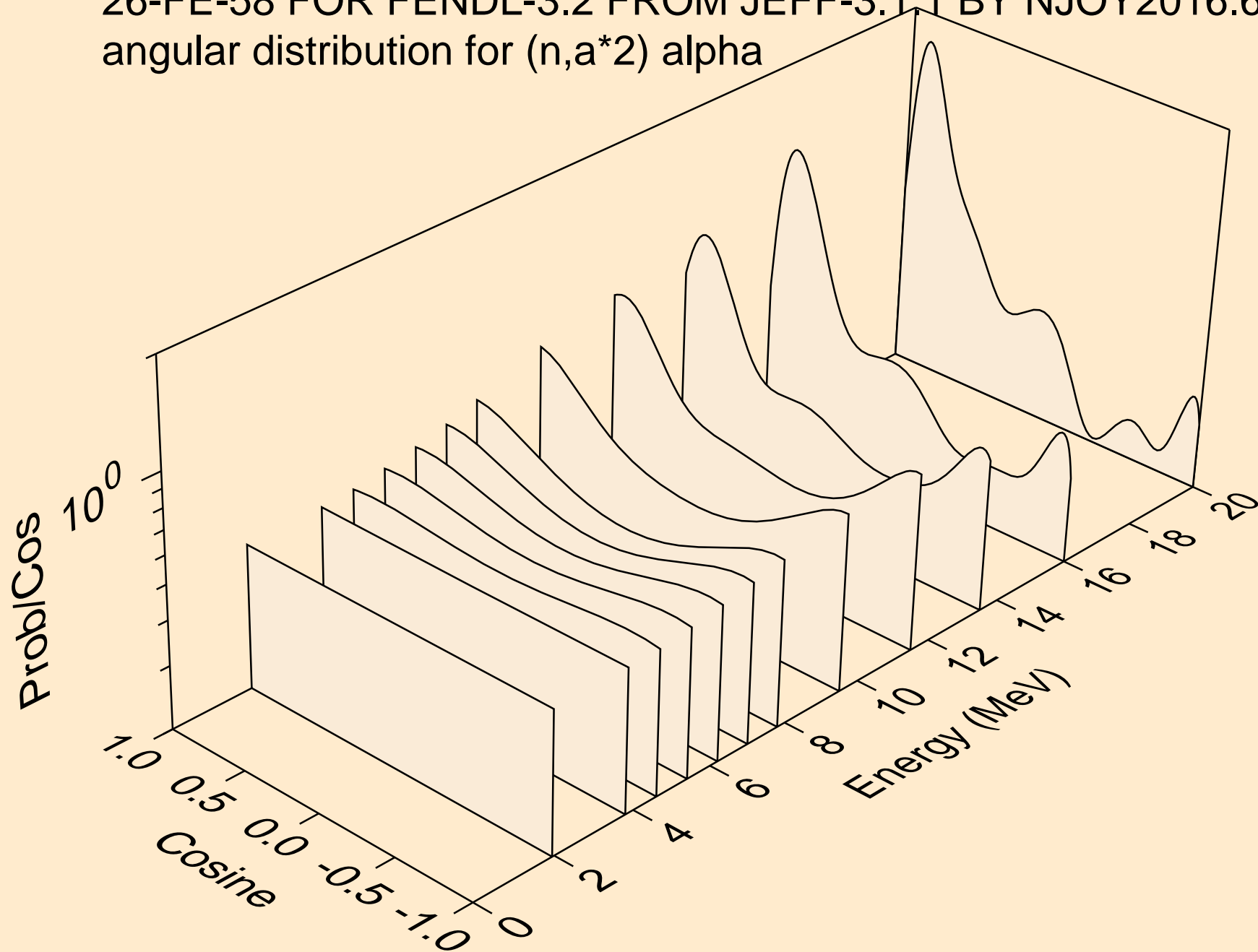

26-FE-58 FOR FENDL-3.2 FROM JEFF-3.1.1 BY NJOY2016.60+ ON
angular distribution for (n,a*3) alpha

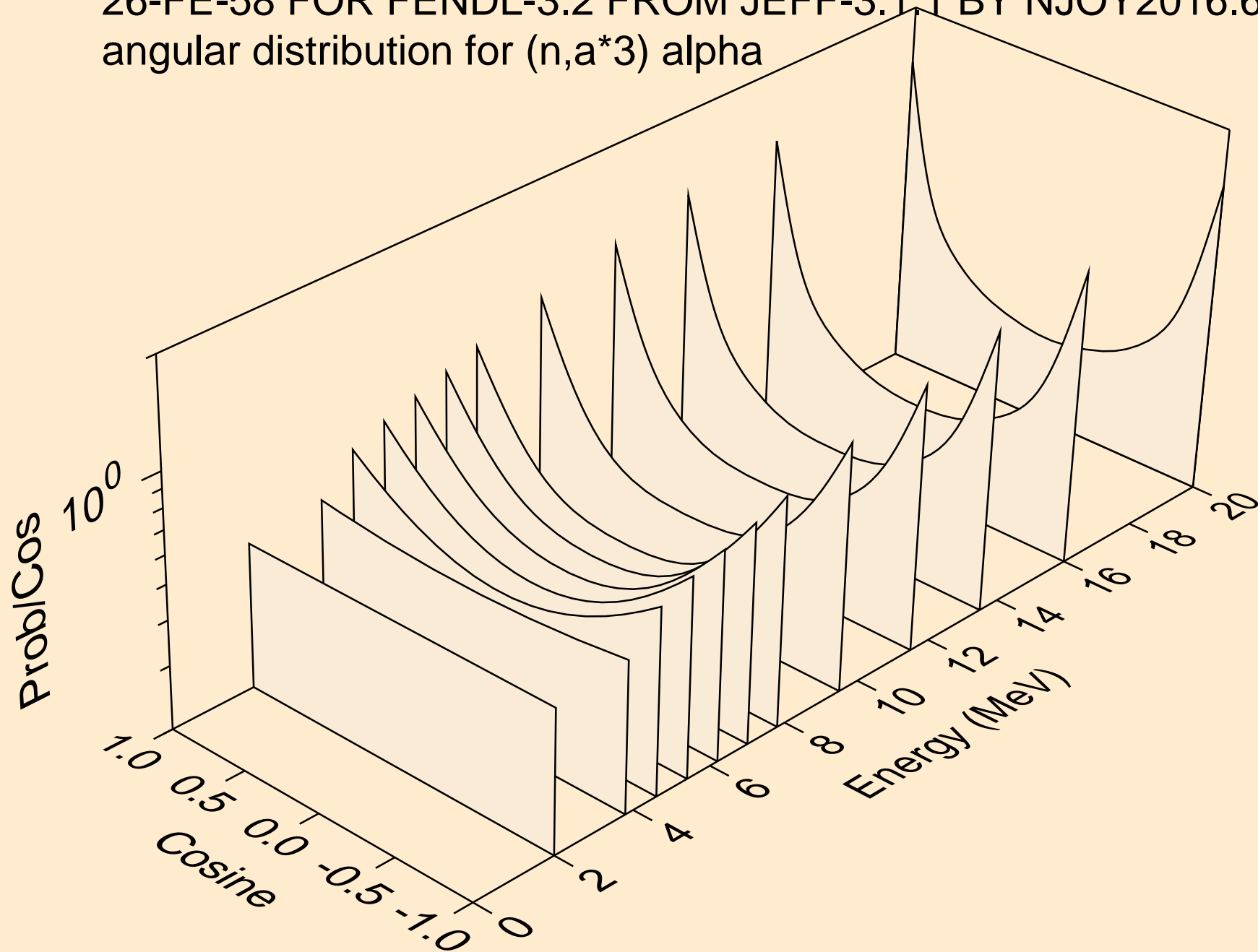

26-FE-58 FOR FENDL-3.2 FROM JEFF-3.1.1 BY NJOY2016.60+ ON
angular distribution for (n,a*4) alpha

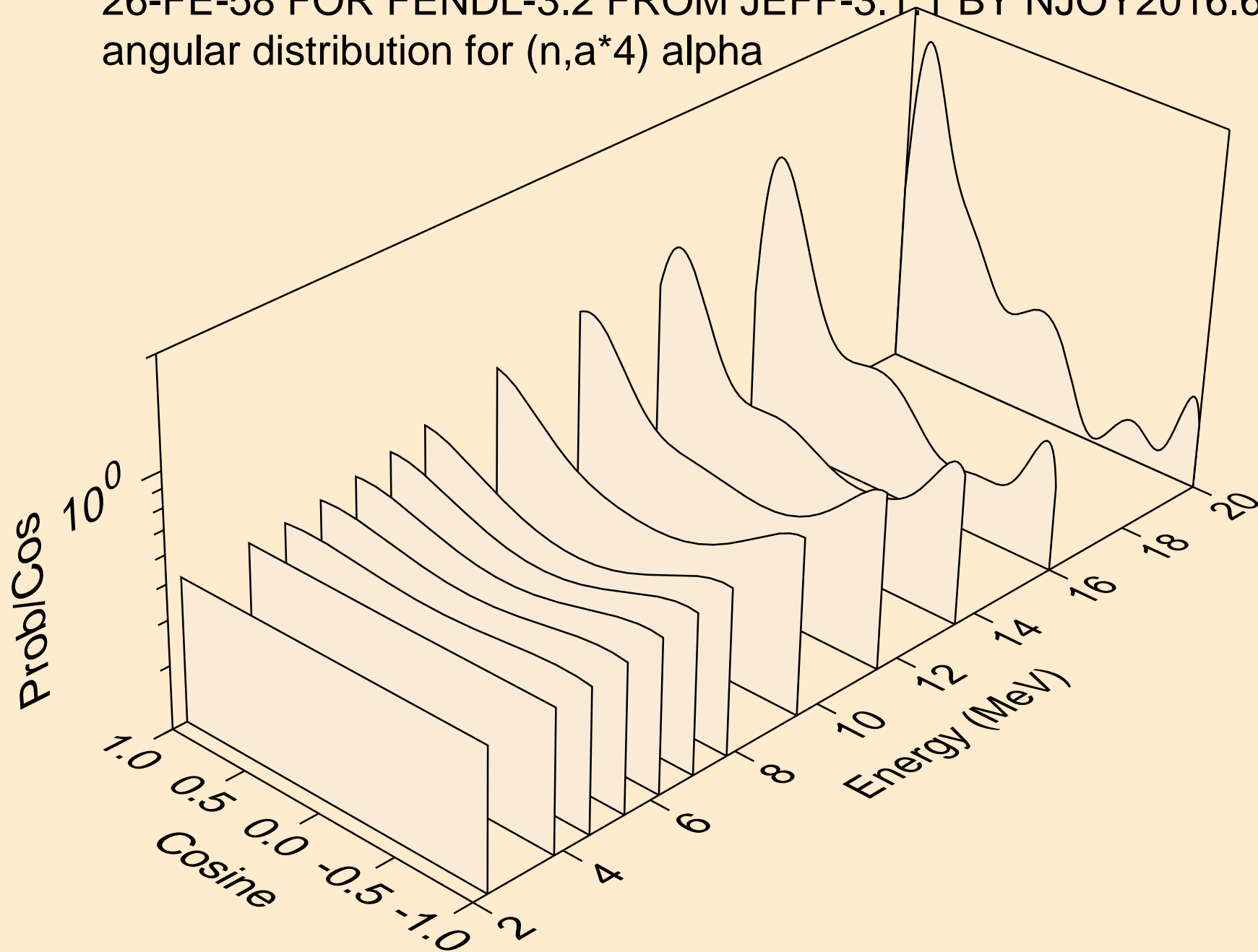

26-FE-58 FOR FENDL-3.2 FROM JEFF-3.1.1 BY NJOY2016.60+ ON
angular distribution for (n,a*5) alpha

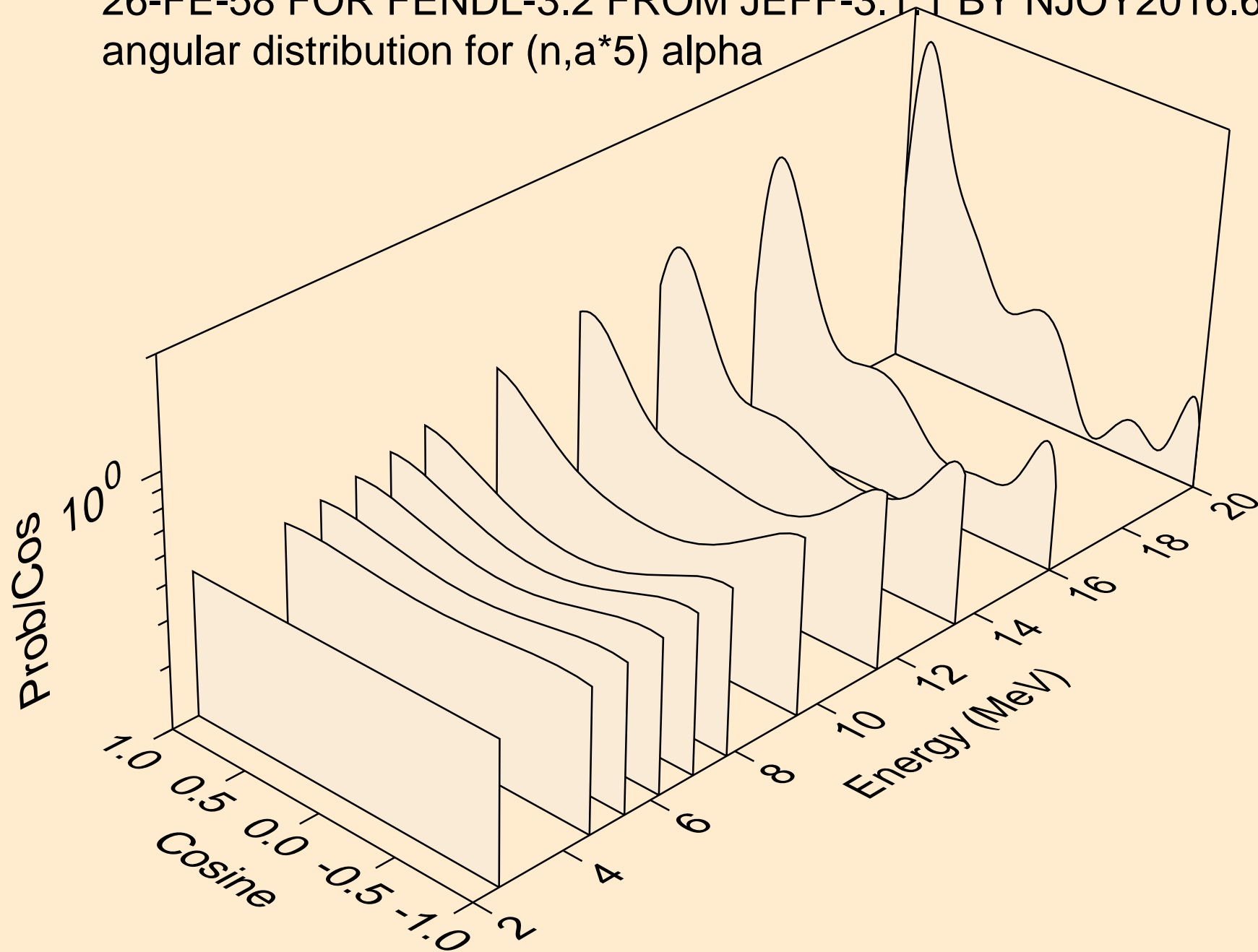

26-FE-58 FOR FENDL-3.2 FROM JEFF-3.1.1 BY NJOY2016.60+ ON
angular distribution for (n,a*6) alpha

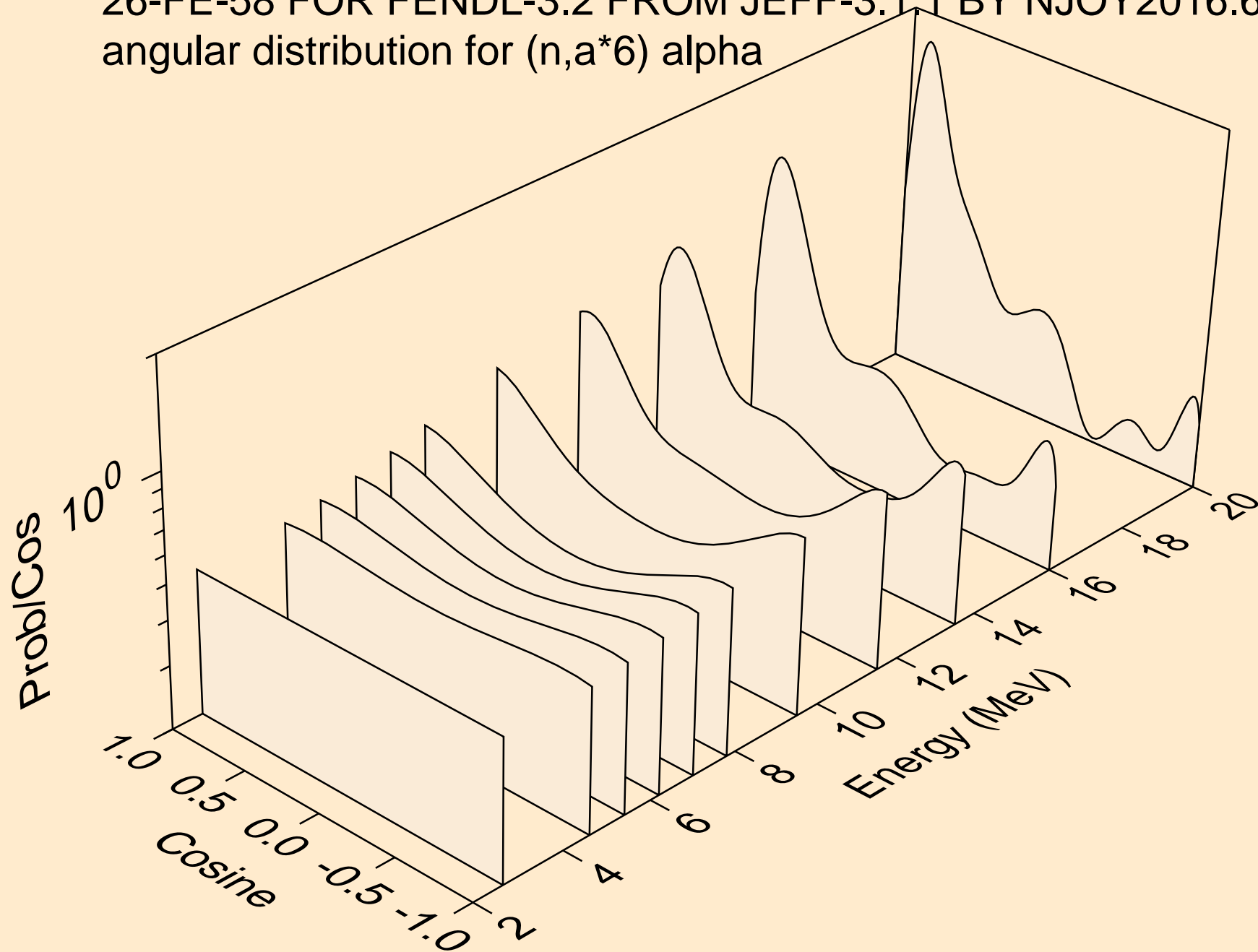

26-FE-58 FOR FENDL-3.2 FROM JEFF-3.1.1 BY NJOY2016.60+ ON
angular distribution for (n,a*7) alpha

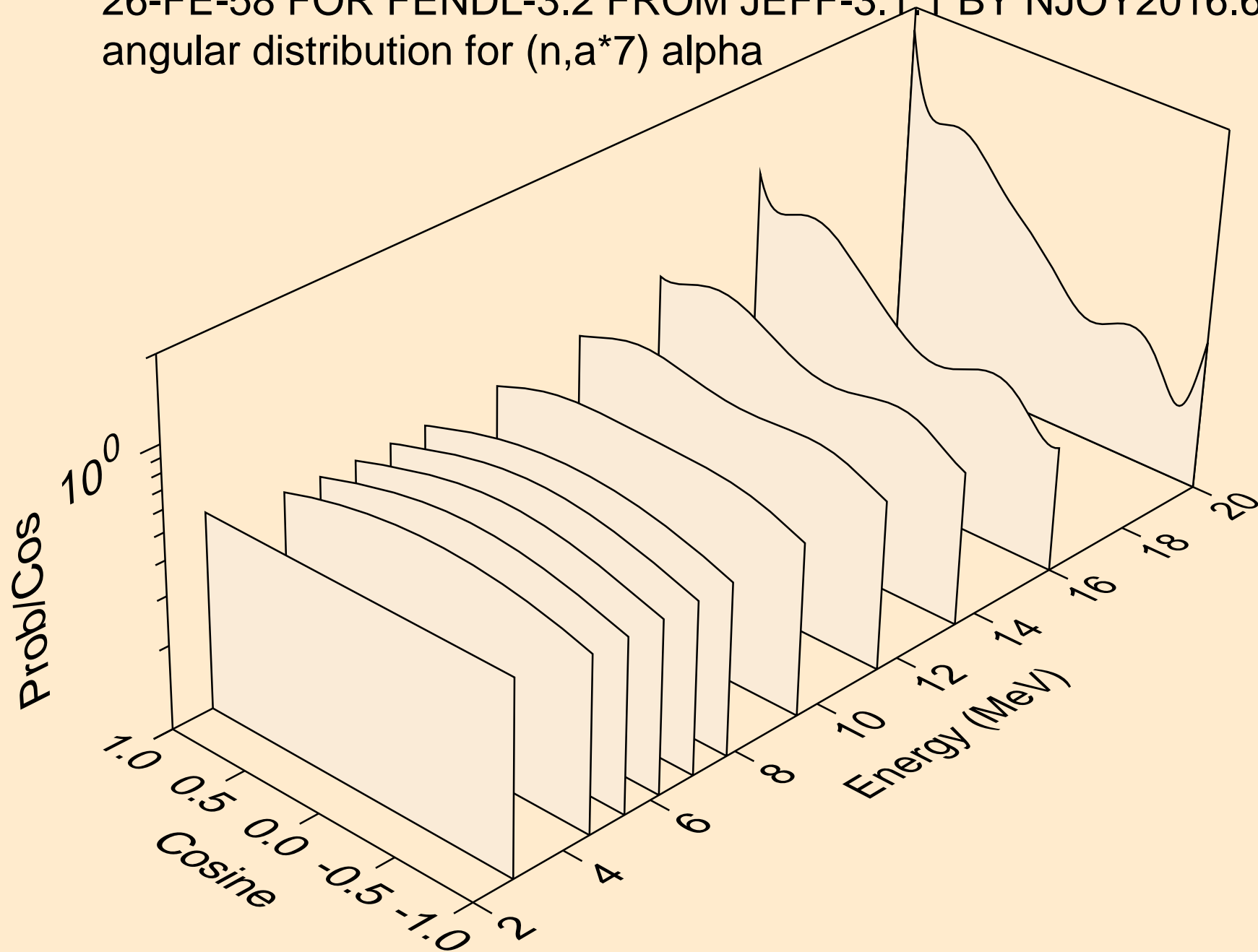

26-FE-58 FOR FENDL-3.2 FROM JEFF-3.1.1 BY NJOY2016.60+ ON
angular distribution for (n,a*8) alpha

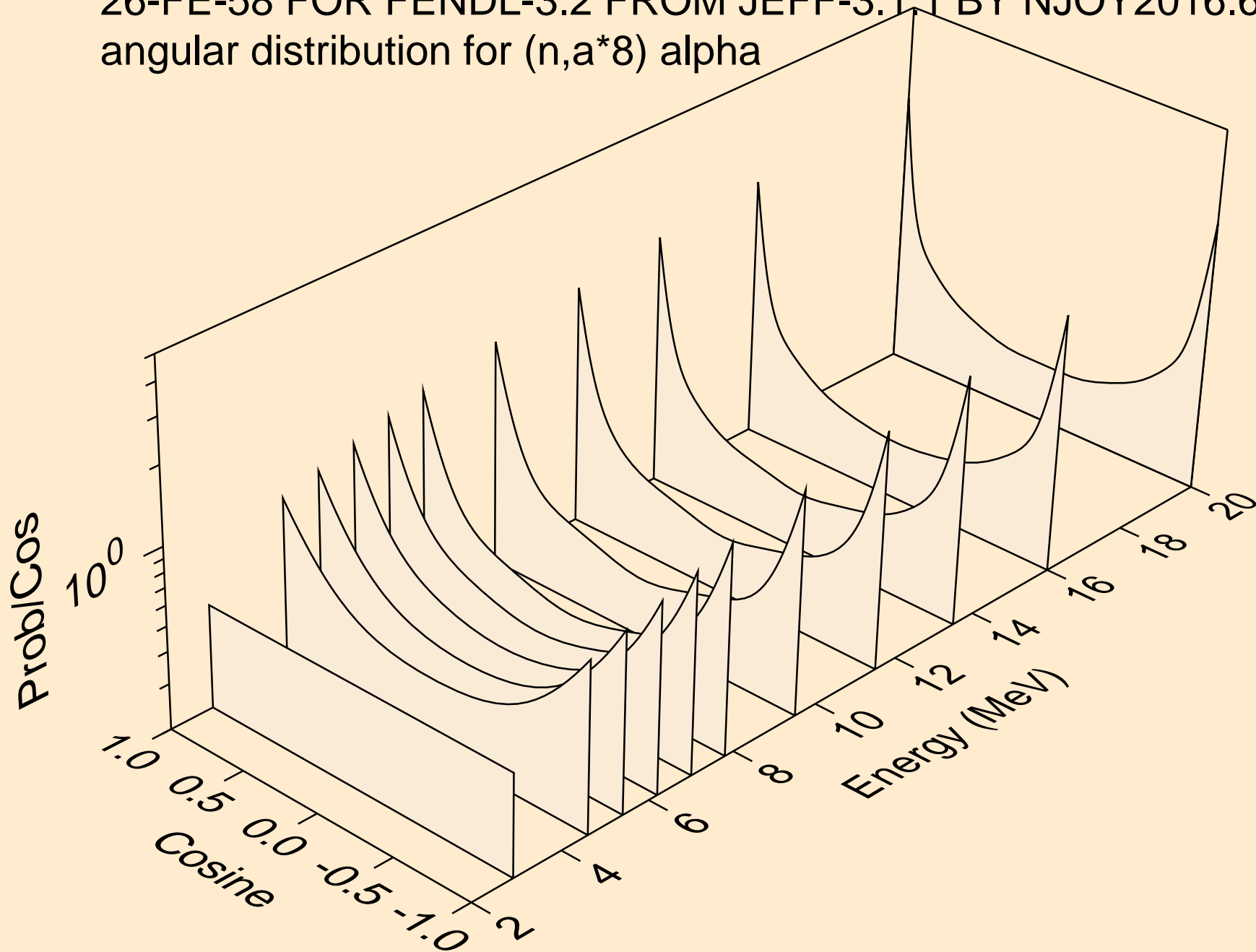

26-FE-58 FOR FENDL-3.2 FROM JEFF-3.1.1 BY NJOY2016.60+ ON
angular distribution for (n,a*9) alpha

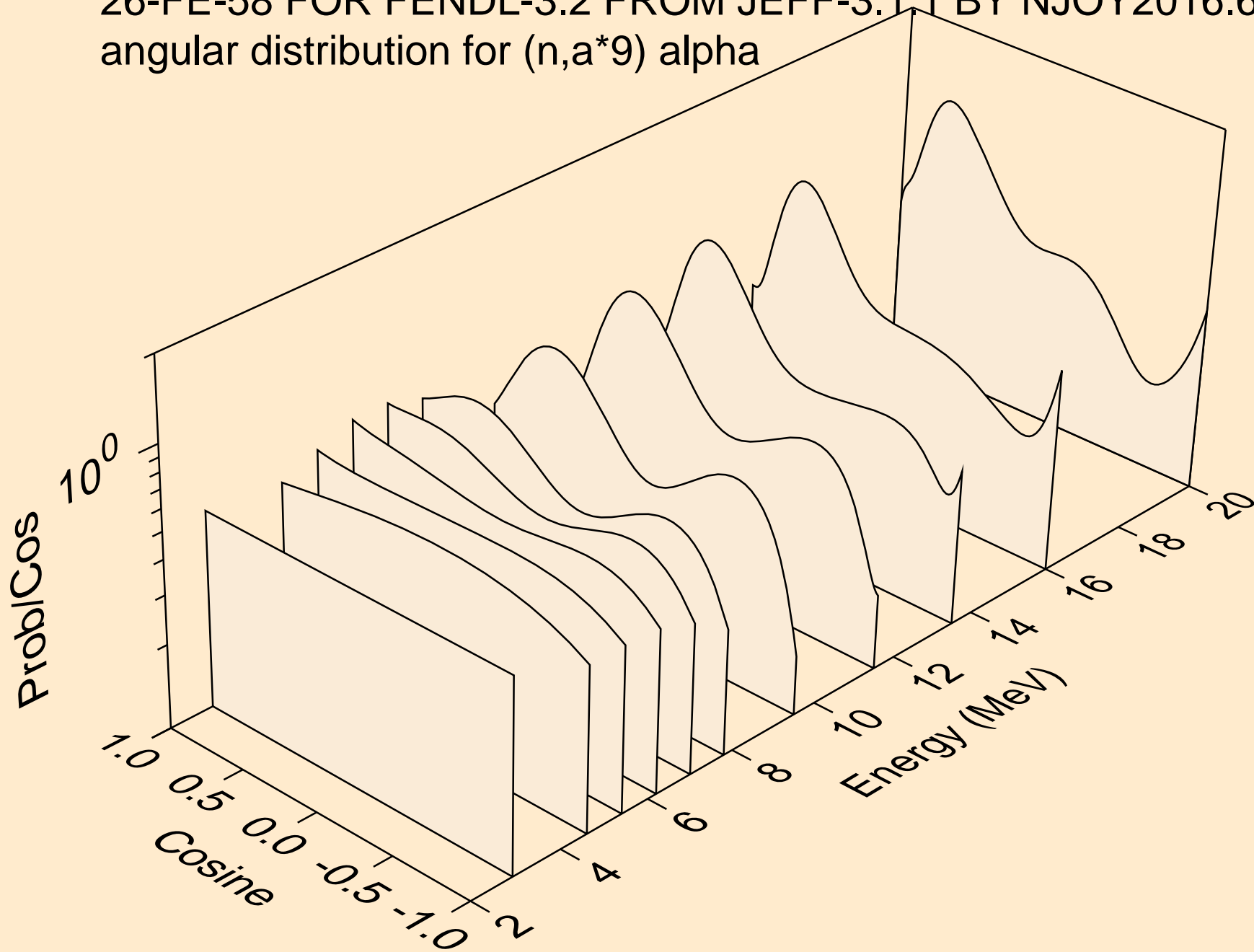

26-FE-58 FOR FENDL-3.2 FROM JEFF-3.1.1 BY NJOY2016.60+ ON
angular distribution for (n,a*10) alpha

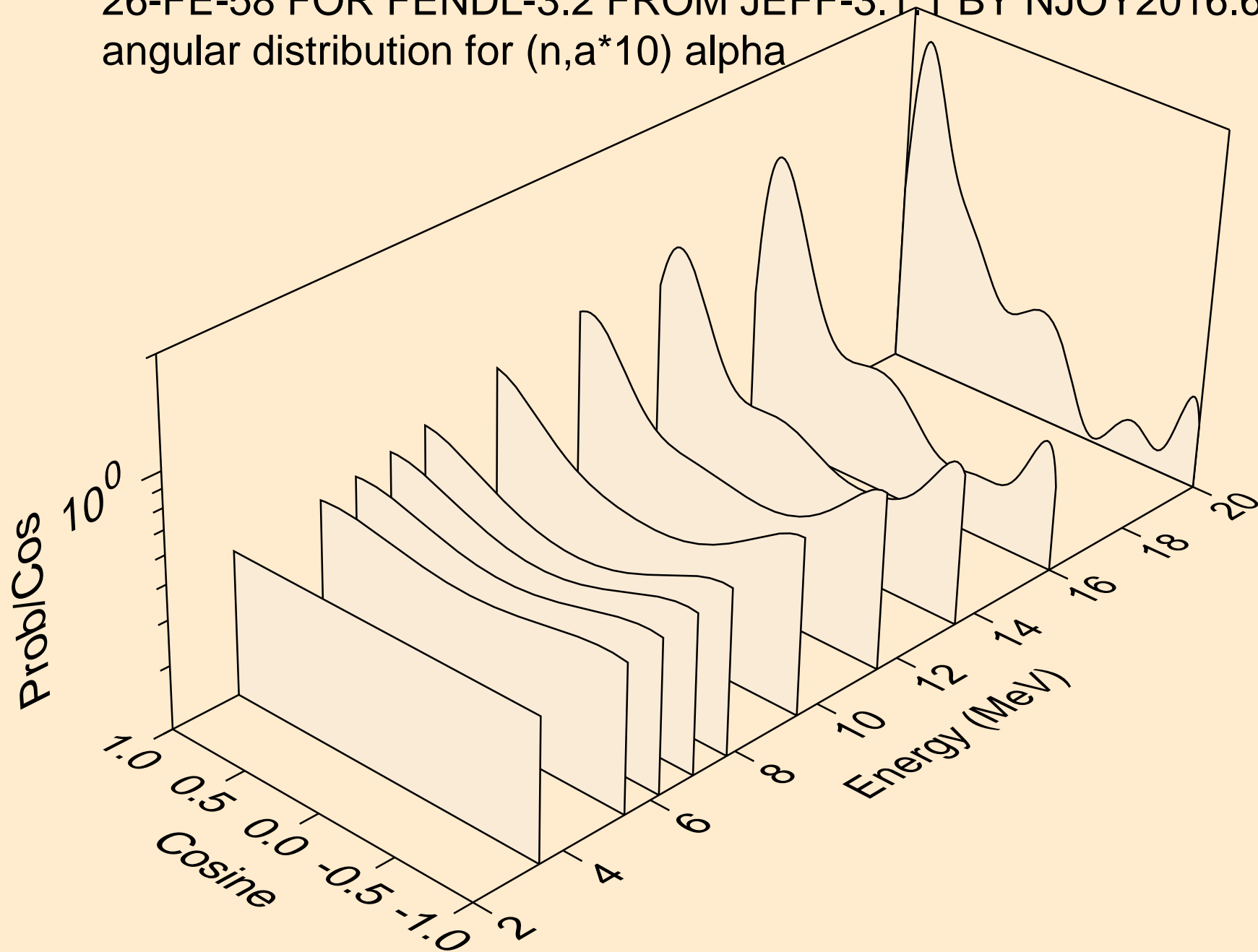

26-FE-58 FOR FENDL-3.2 FROM JEFF-3.1.1 BY NJOY2016.60+ ON
alphas from (n,a*c)

