

DINAMO/ZVView.  
Software for Interactive Visual Analysis of Nuclear Data  
*V.Zerkin*

**DINAMO.** Multiplatform,  
universal graphic software tool.

**Fields:**

- real-time (acquisition)
- data treatment
- data presentation

**Developer oriented features:**

- functions:  $f(x)$ ,  $f(x,y)$
- not fixed number of functions  
and data type (arrays  
 $I2, \dots, R8, ExtrnFunc.$ )
- expandable functionality
- many platforms

**User oriented functionality:**

- on-line help
- fast
- multi language
- many plotting options and useful functions
- smoothing, etc.

**ZVView.** Tool for interactive visual  
analysis of nuclear data.

**Purposes:**

- comparison of experimental and  
evaluated data of different authors,  
and different libraries
- interactive manipulations and  
visual data analysis

**Specific functions:**

- works with list of authors and their  
experimental points
- comparison data of authors, etc.

**Future:**

- integration with data retrieval  
systems (Web, On-line, BNL-325)
- wider using, accept new users needs
- more formats and types of data, etc.

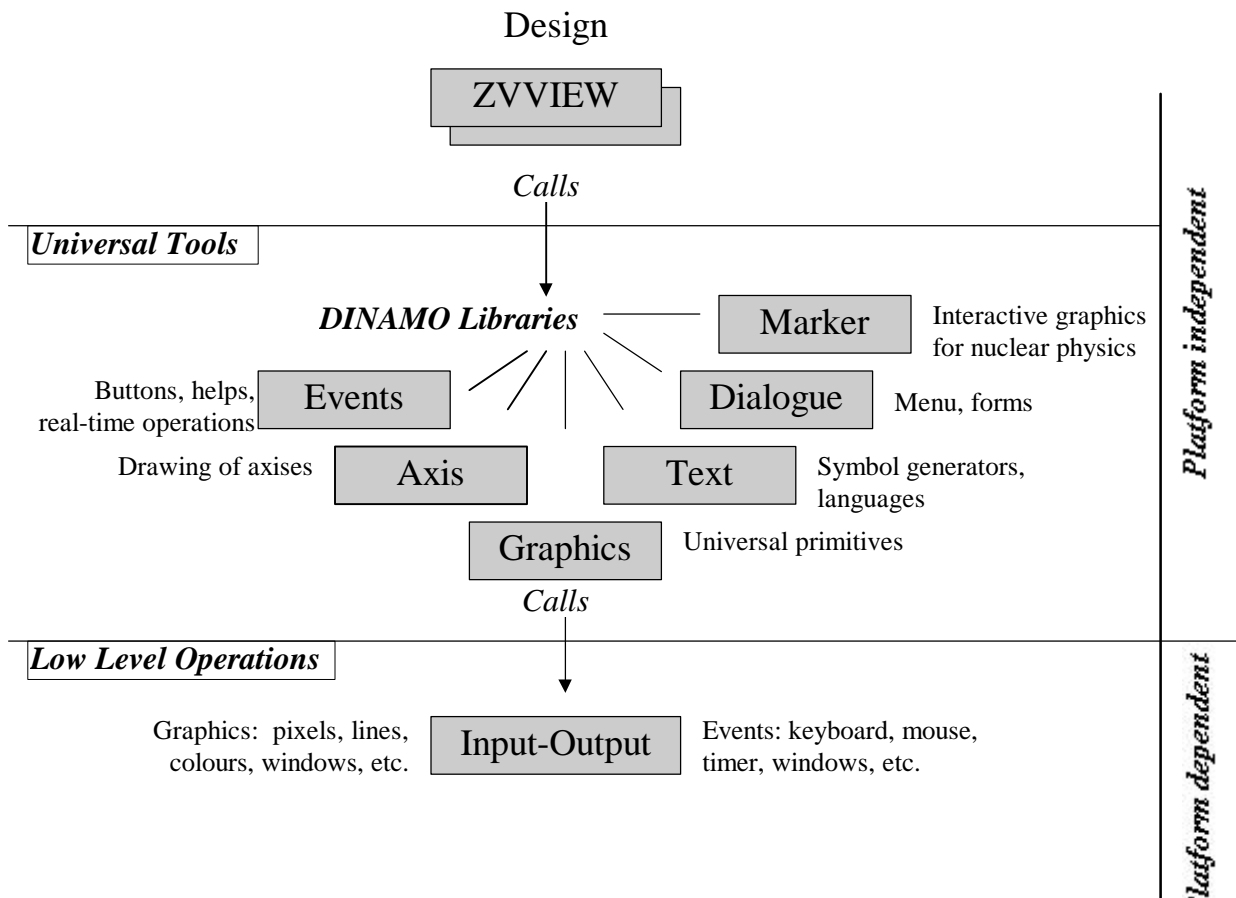

## ZVView/DINAMO platforms

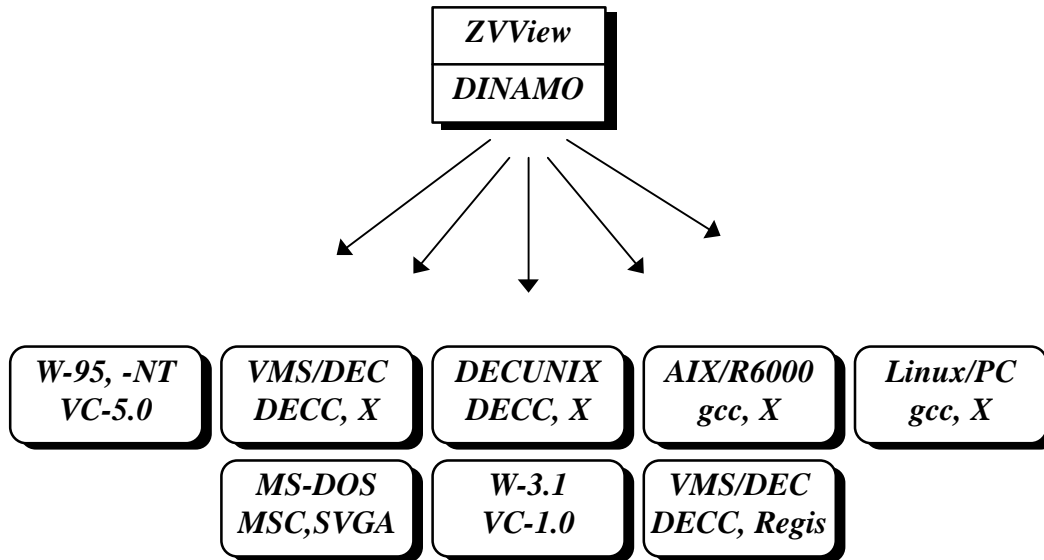

## ZVView input data

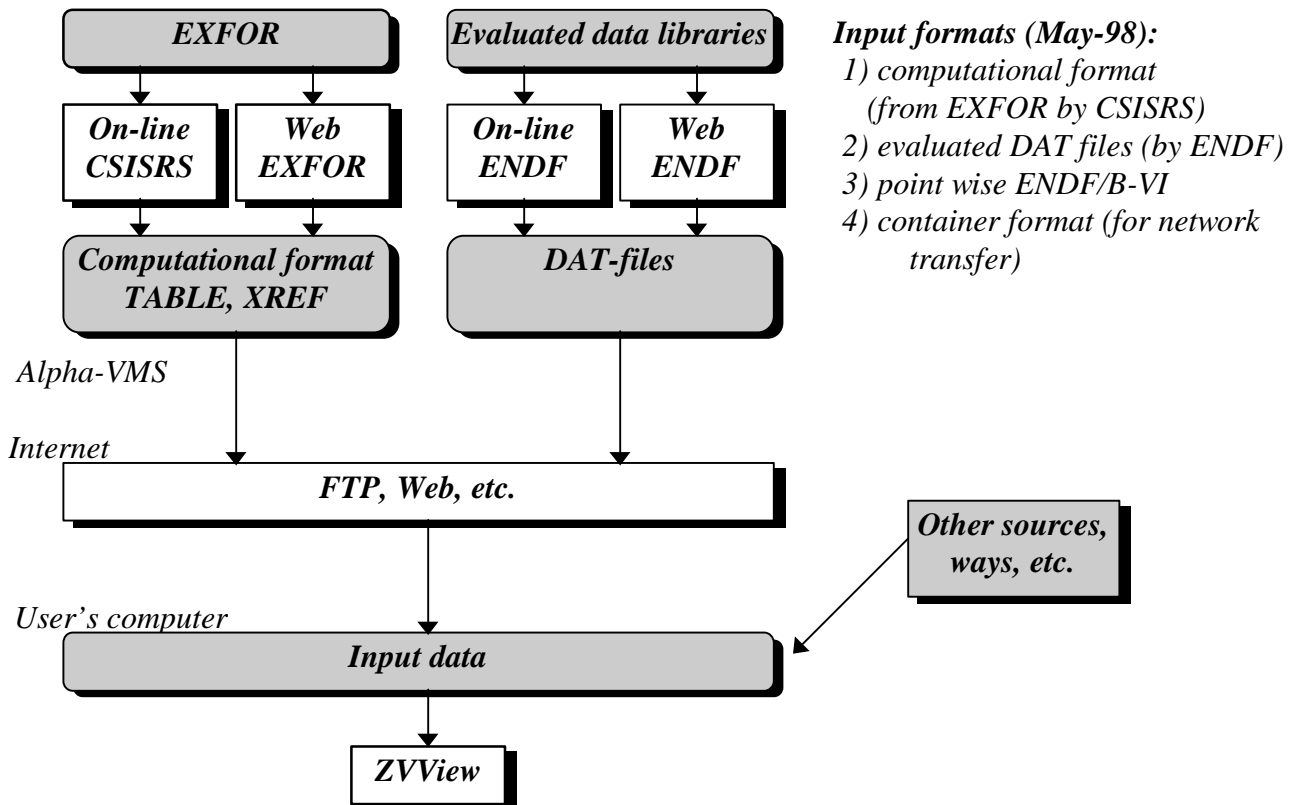

Remote EXFOR & ENDF data retrievals  
and local analysis by ZVView  
under Web technology  
(proposal)

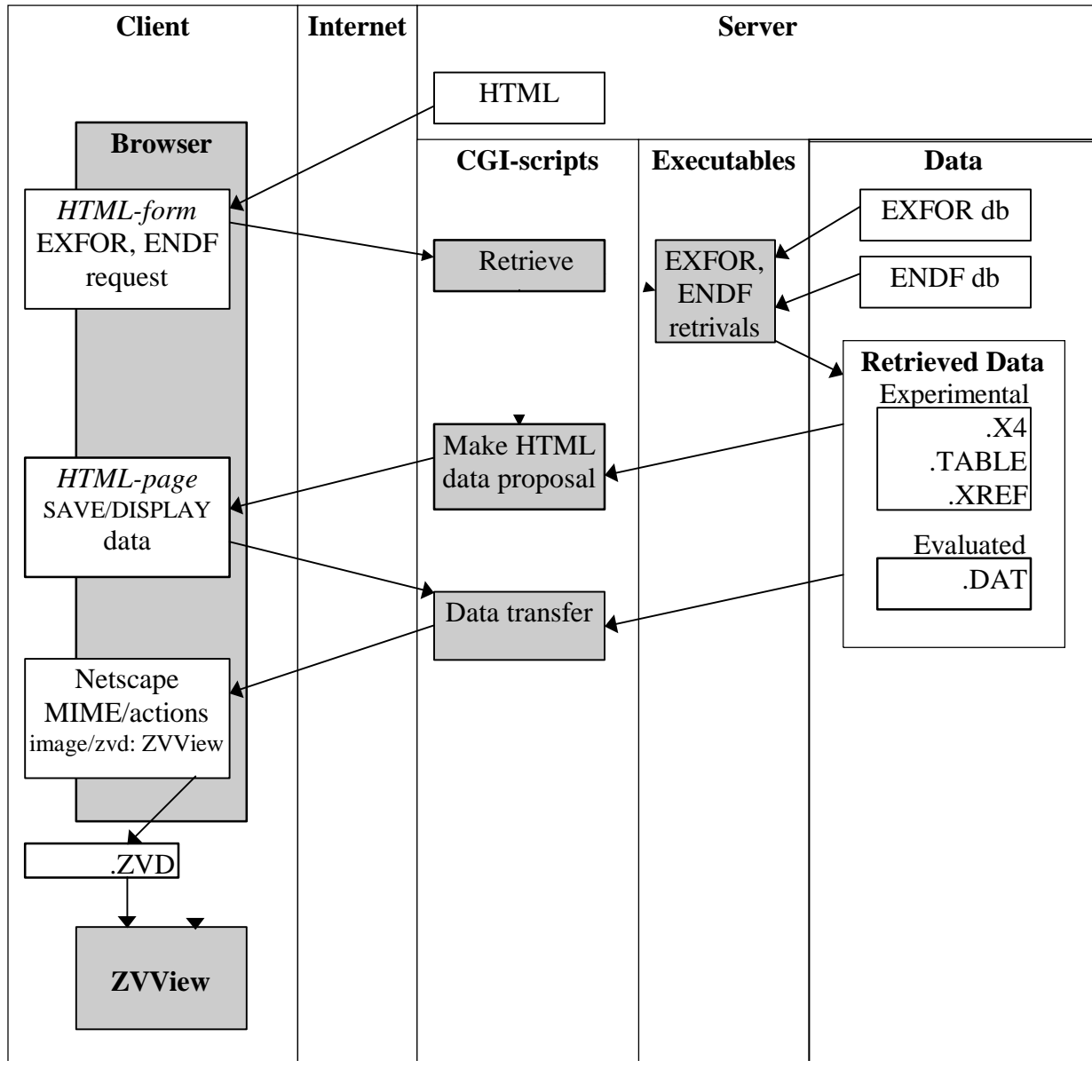

Flows:  
 ———▶ Data  
 ———▶ Calls

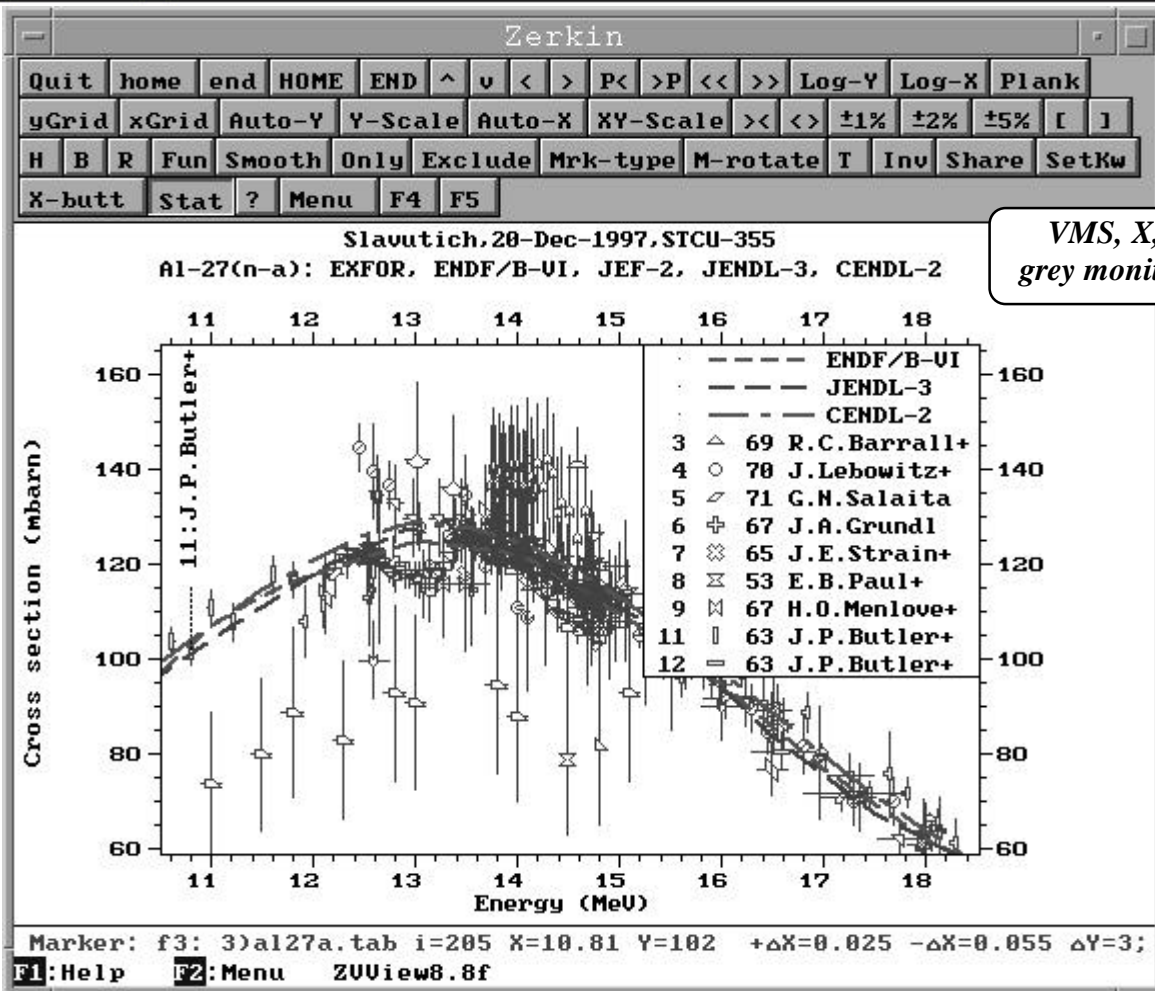
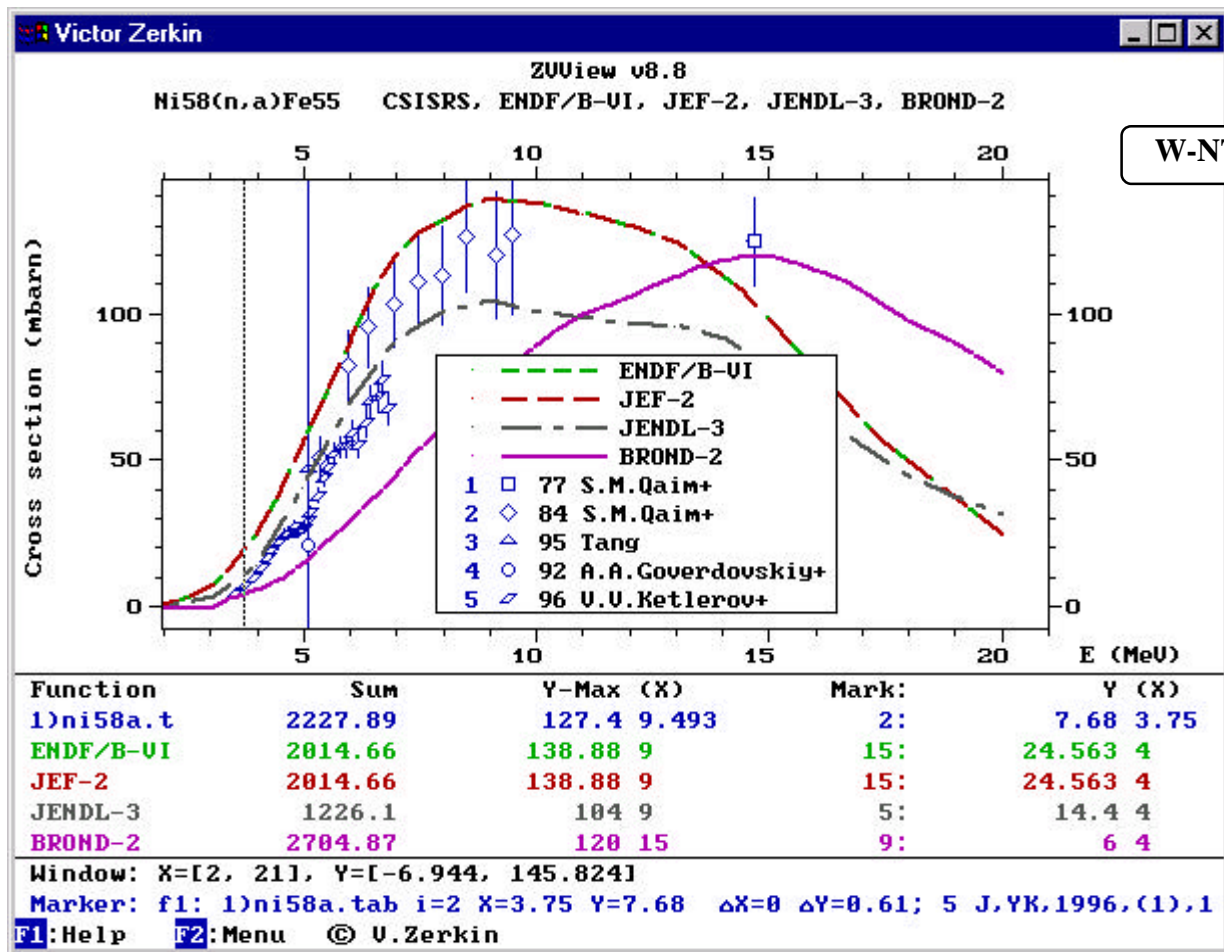

© V.V.Zerkin, Kiev, 265-43-71

Output file: D:\Tmp.d00

I Total events: 552 Sorted: 552  
Events in file: 510 File: 8.704/b  
20:36:09 W-Buf: 1 / 510 OK.  
Counters: 0 552 363 [1/2]=0 [2/3]=1.521  
20:30:34 Acquisition is in progres

Now: 30-Sep-1995 20:36:36

Start: 30-Sep-1995 20:30:34

Elapsed Time: 0 00:06:02

Buf1  0%

Buf2  8%

File  0%

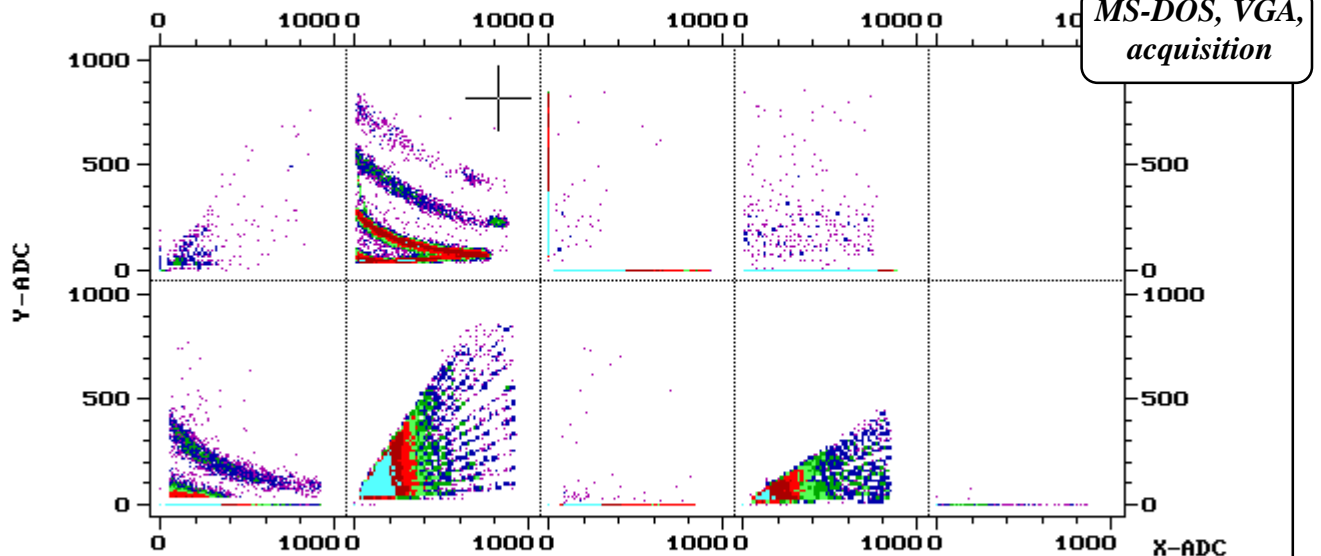

MS-DOS, VGA,  
acquisition

| Функция | Сумма | Z-мак (X,Y) | Маркер:  | Z (X,Y)   |
|---------|-------|-------------|----------|-----------|
| E1*ΔE1  | 57639 | 9592 1,1    | 105,104: | 0 833,825 |
| E1*EX1  | 57639 | 9594 1,1    | 53,53:   | 0 833,833 |
| E2*ΔE2  | 57639 | 48003 1,1   | 105,104: | 0 833,825 |
| E2*EX2  | 57639 | 48003 1,1   | 53,53:   | 0 833,833 |

Окно: X=[-49.8, 1067.8], Y=[-49.8, 1067.8]

Маркер: f7: E3\*ΔE3 i=105 j=104 X=833 Y=825 Z=0

F1: Помощь F2: Меню View

