

74-W-182 FROM INDL-2008 WITH NJOY99.259.NEA042, FEB. 200
Principal cross sections

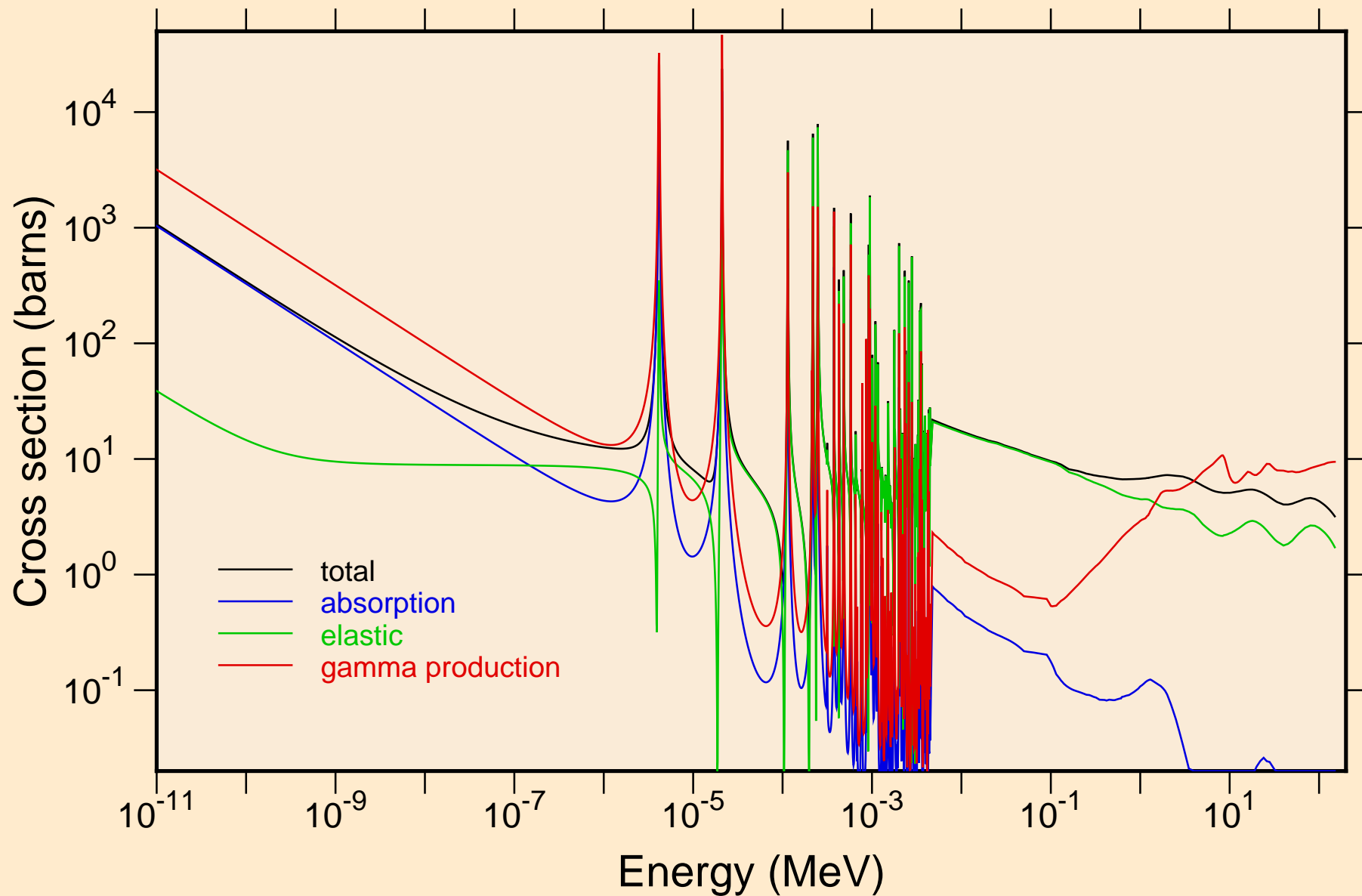

74-W-182 FROM INDL-2008 WITH NJOY99.259.NEA042, FEB. 200
resonance total cross section

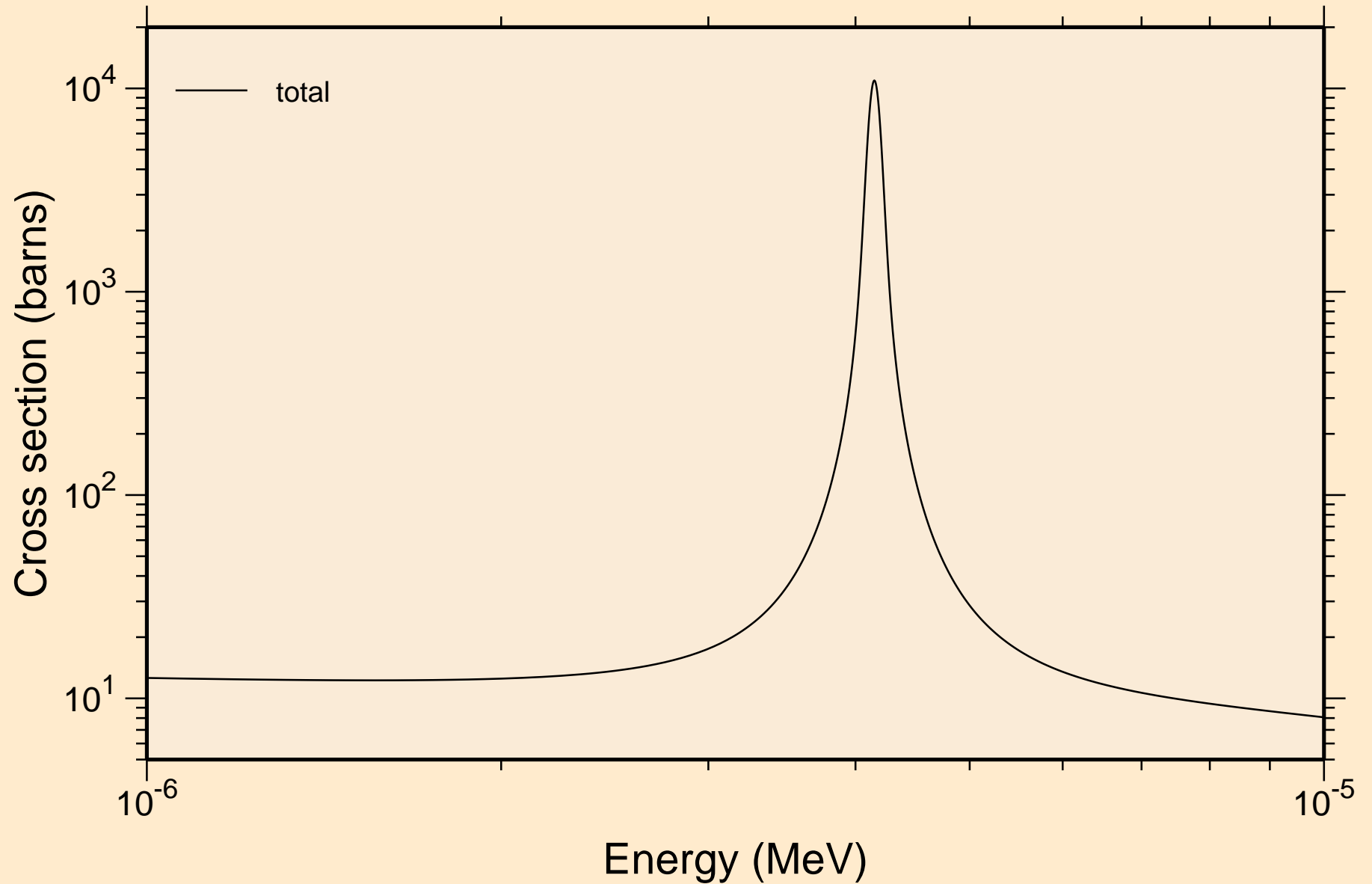

74-W-182 FROM INDL-2008 WITH NJOY99.259.NEA042, FEB. 200
resonance total cross section

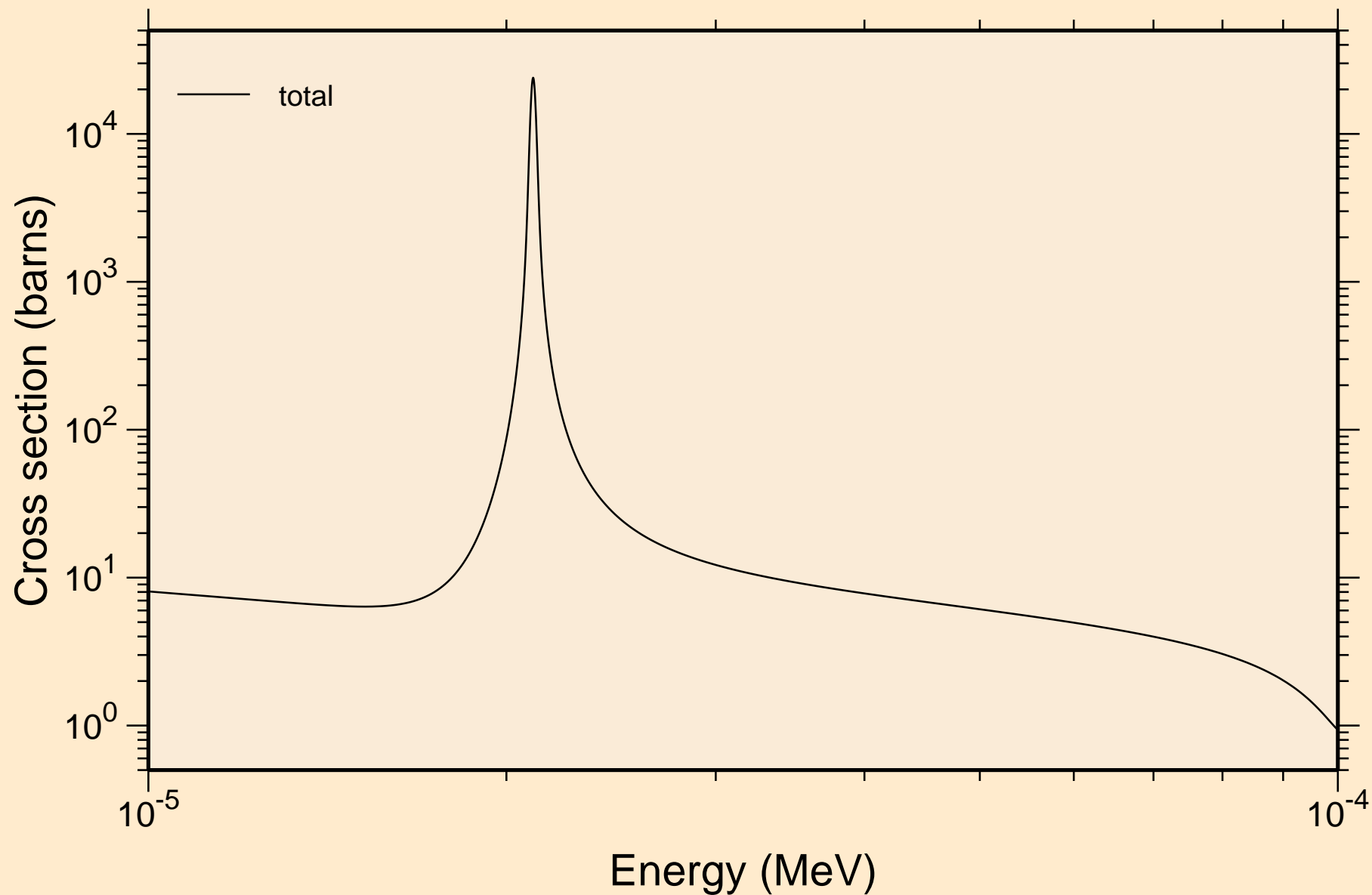

74-W-182 FROM INDL-2008 WITH NJOY99.259.NEA042, FEB. 200
resonance total cross section

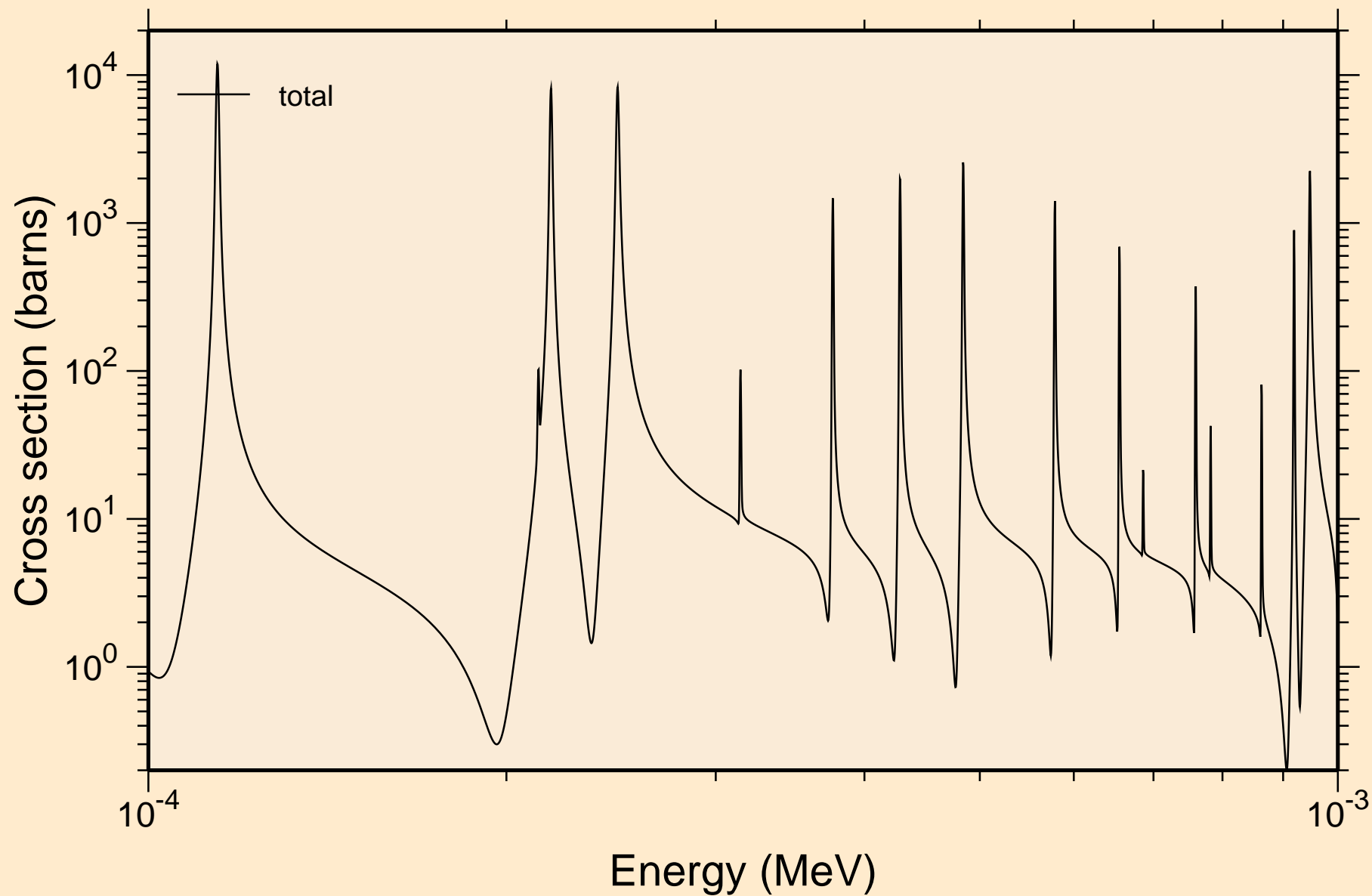

74-W-182 FROM INDL-2008 WITH NJOY99.259.NEA042, FEB. 200
resonance total cross section

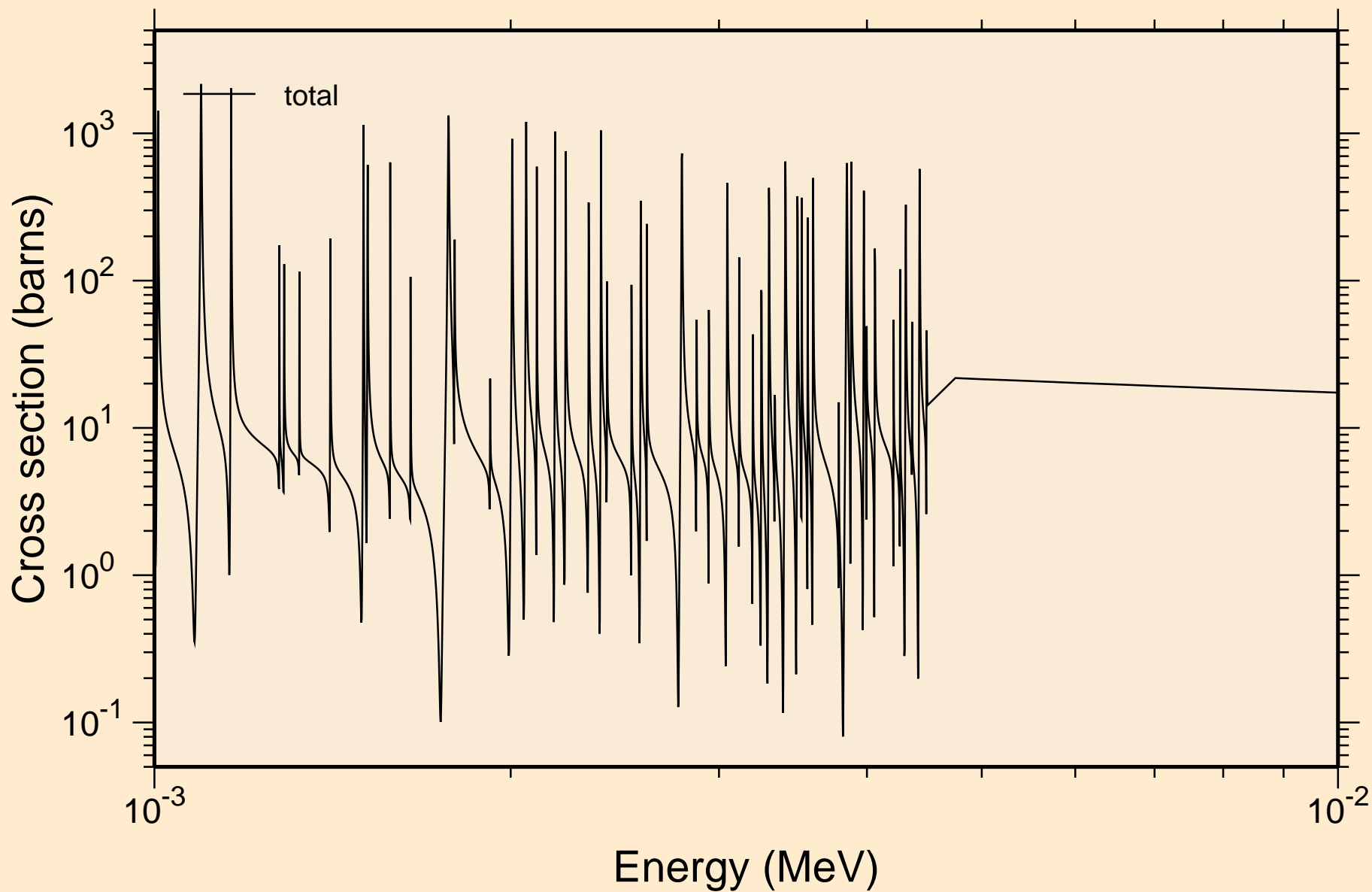

74-W-182 FROM INDL-2008 WITH NJOY99.259.NEA042, FEB. 200
resonance absorption cross sections

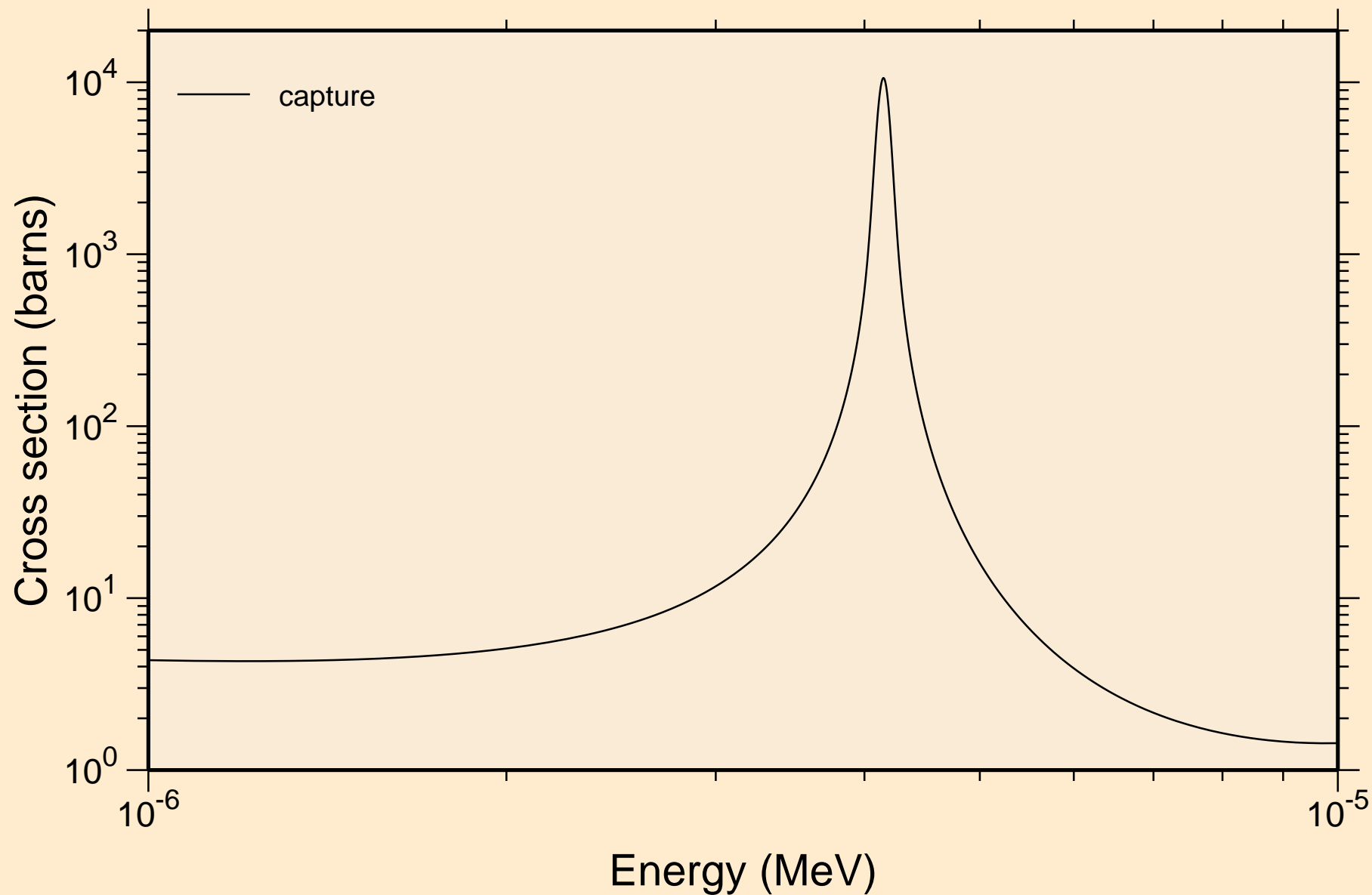

74-W-182 FROM INDL-2008 WITH NJOY99.259.NEA042, FEB. 200
resonance absorption cross sections

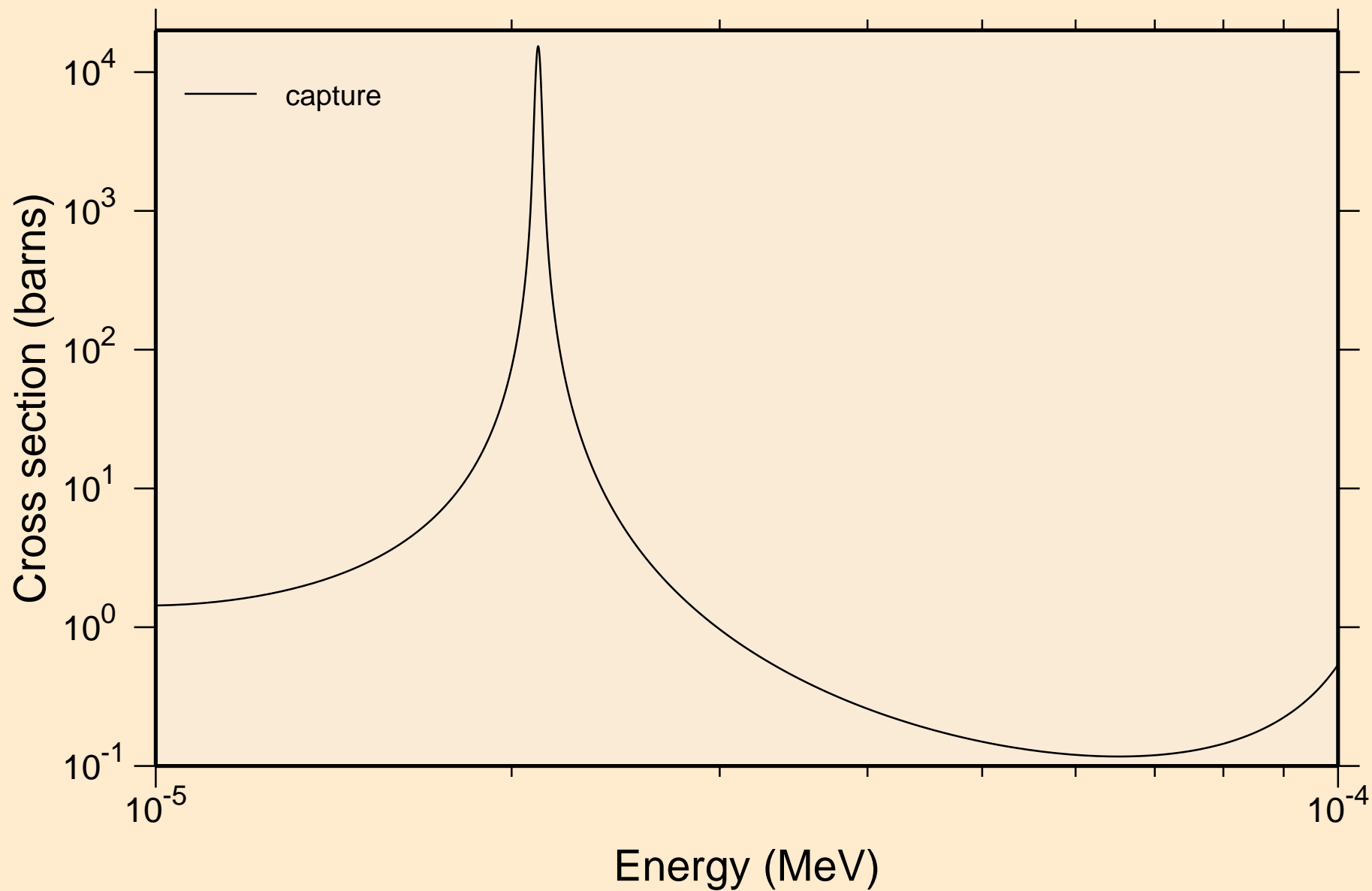

74-W-182 FROM INDL-2008 WITH NJOY99.259.NEA042, FEB. 200
resonance absorption cross sections

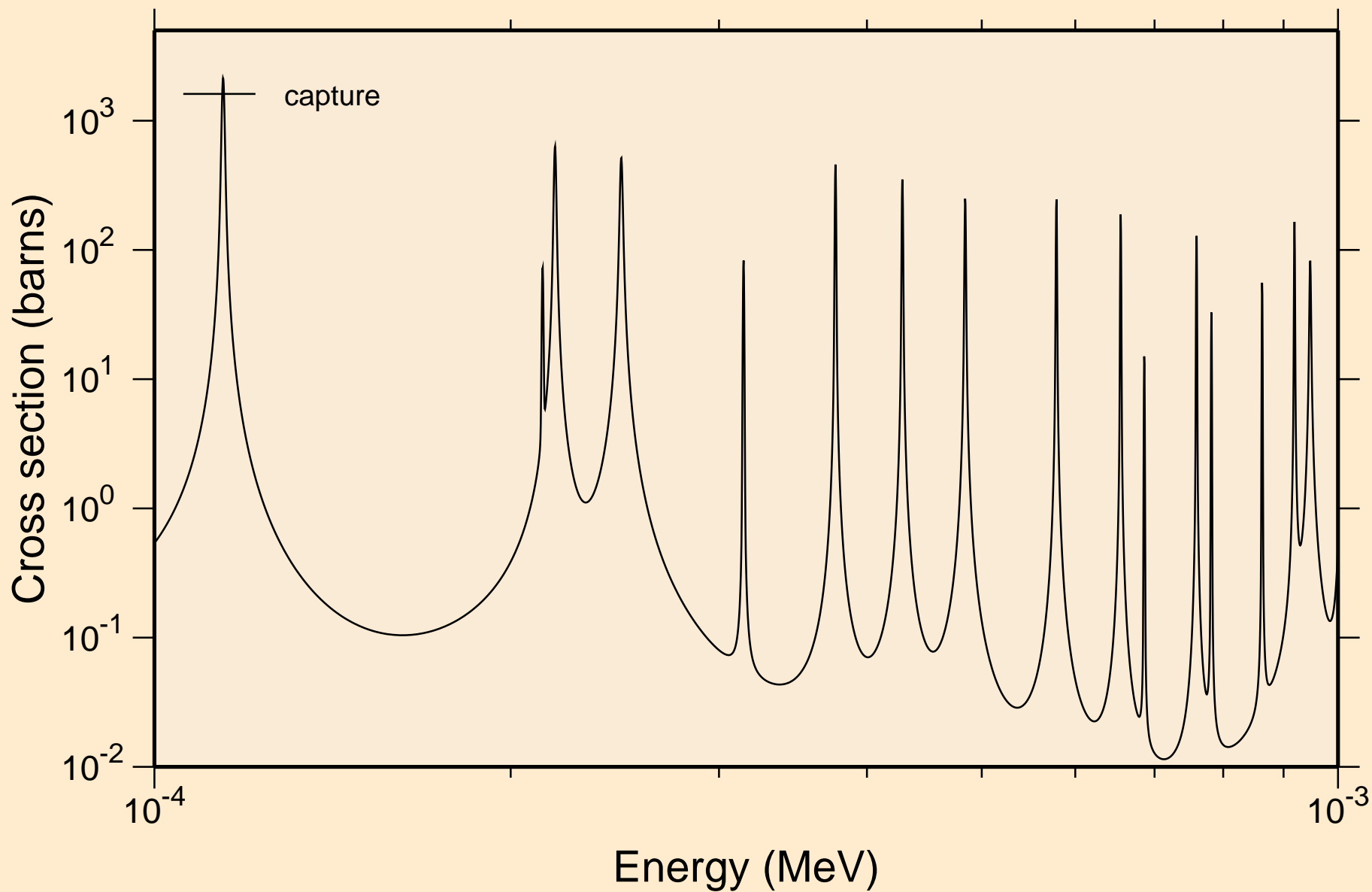

74-W-182 FROM INDL-2008 WITH NJOY99.259.NEA042, FEB. 200
resonance absorption cross sections

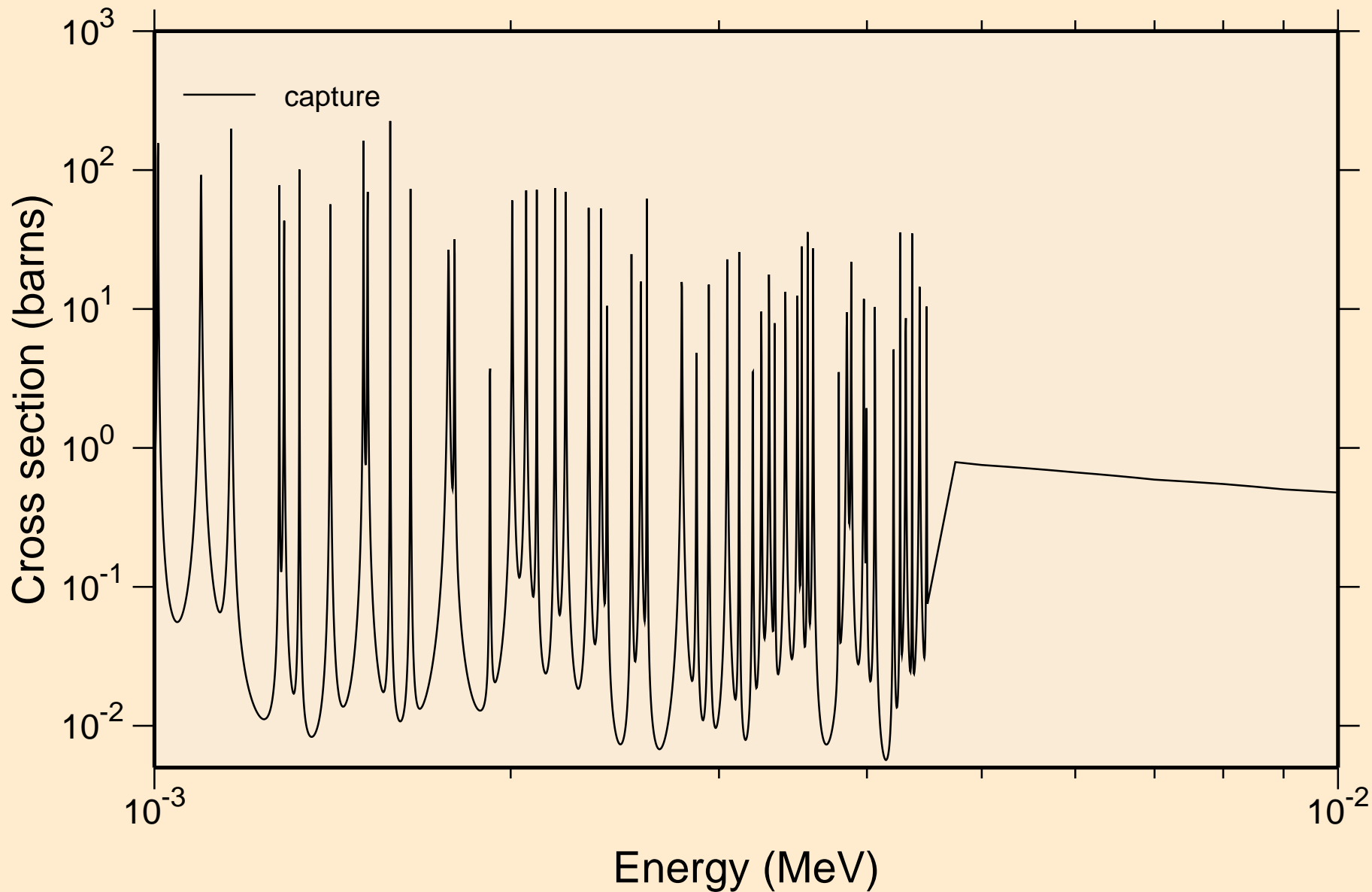

74-W-182 FROM INDL-2008 WITH NJOY99.259.NEA042, FEB. 200 Heating

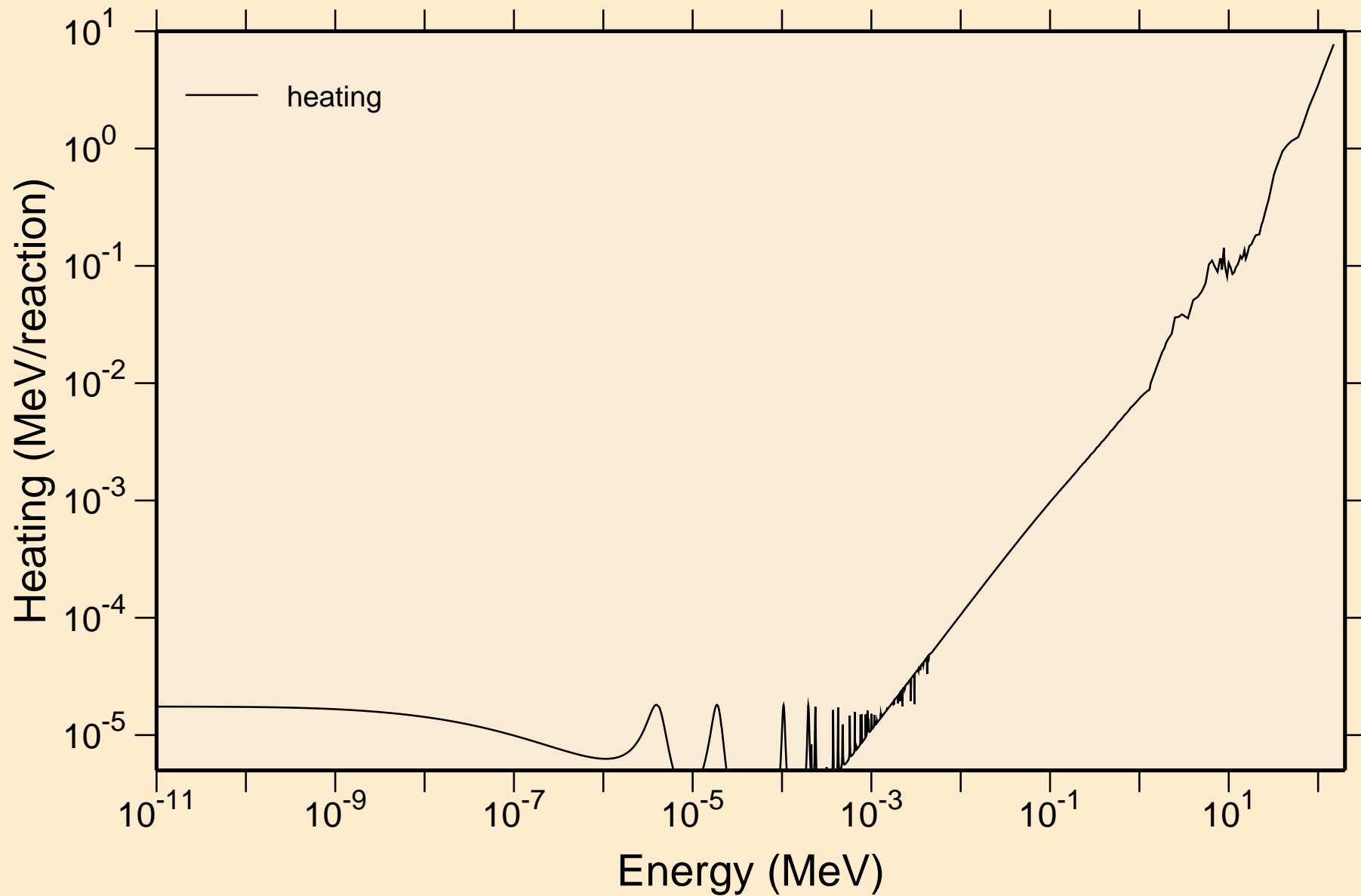

74-W-182 FROM INDL-2008 WITH NJOY99.259.NEA042, FEB. 200

Damage

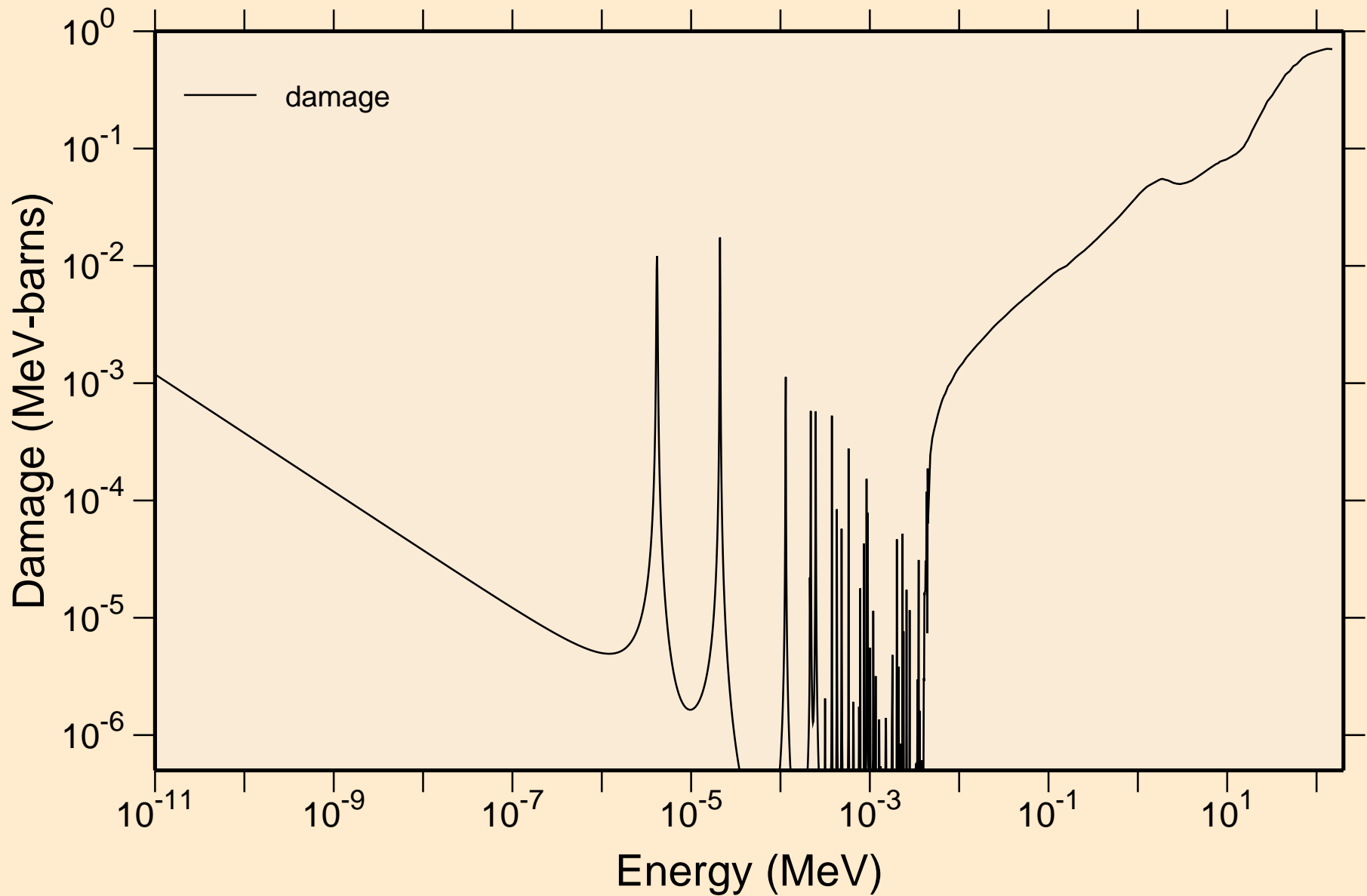

74-W-182 FROM INDL-2008 WITH NJOY99.259.NEA042, FEB. 200
Non-threshold reactions

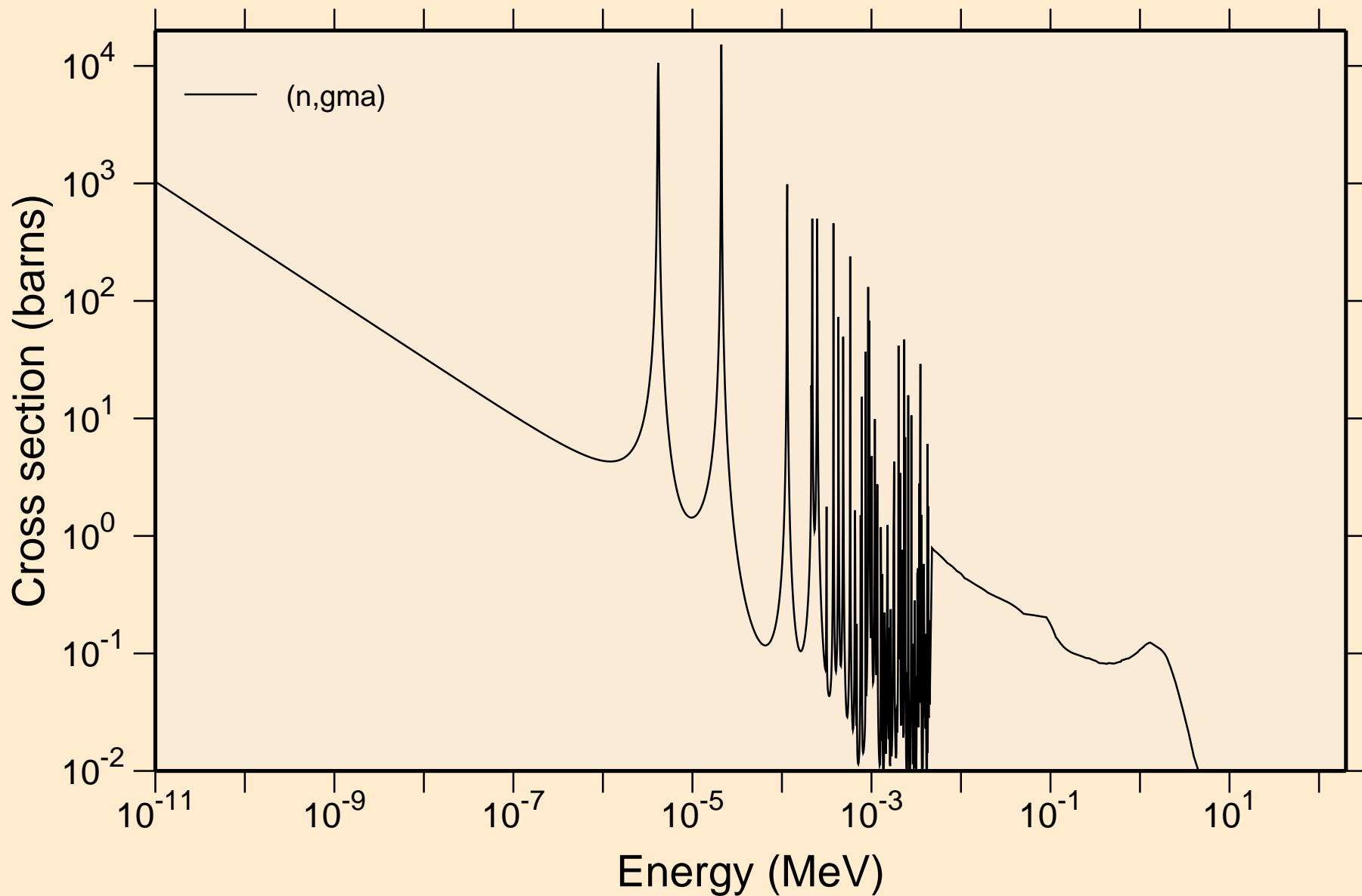

74-W-182 FROM INDL-2008 WITH NJOY99.259.NEA042, FEB. 200
Principal cross sections

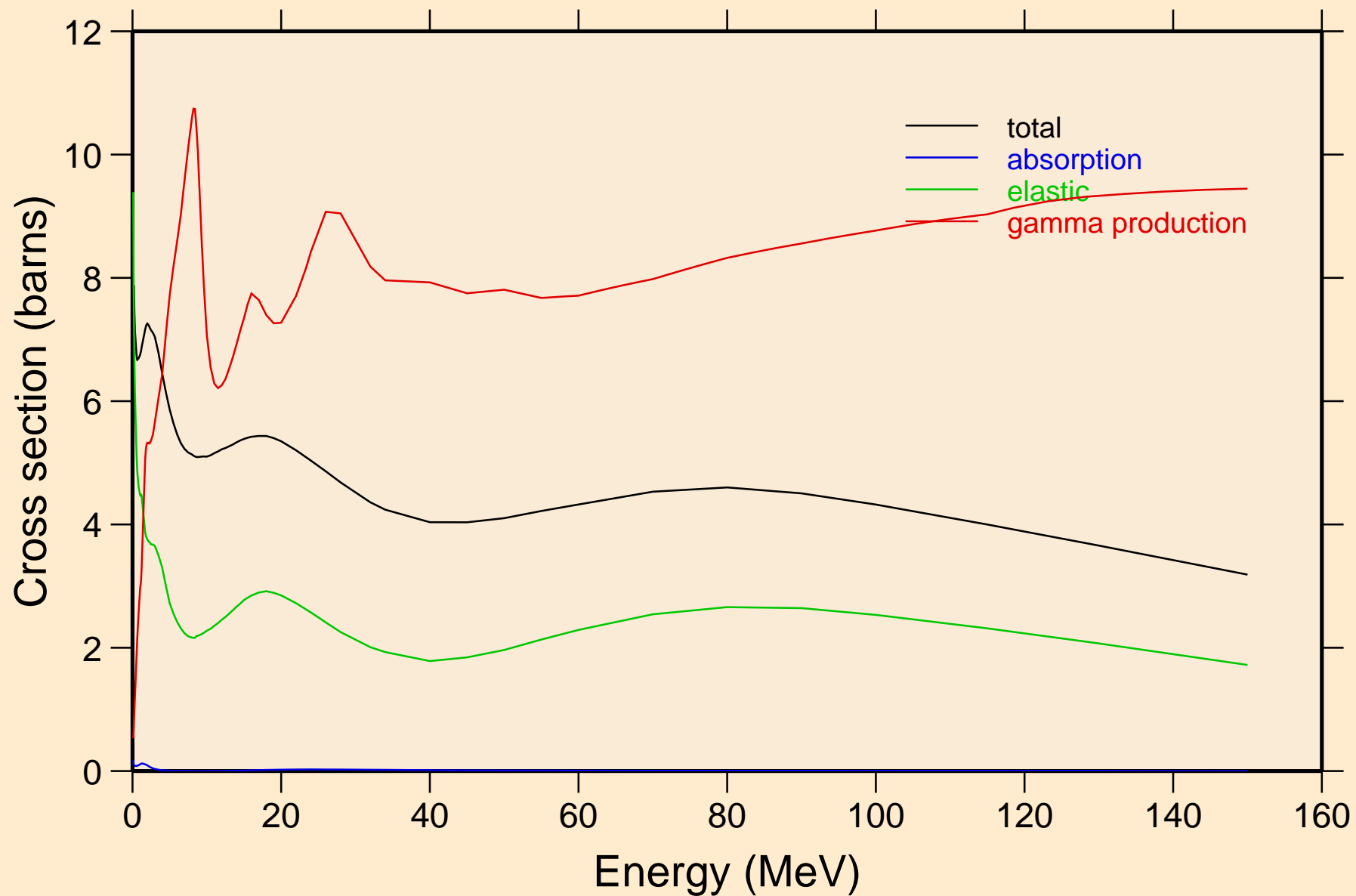

74-W-182 FROM INDL-2008 WITH NJOY99.259.NEA042, FEB. 200

Heating

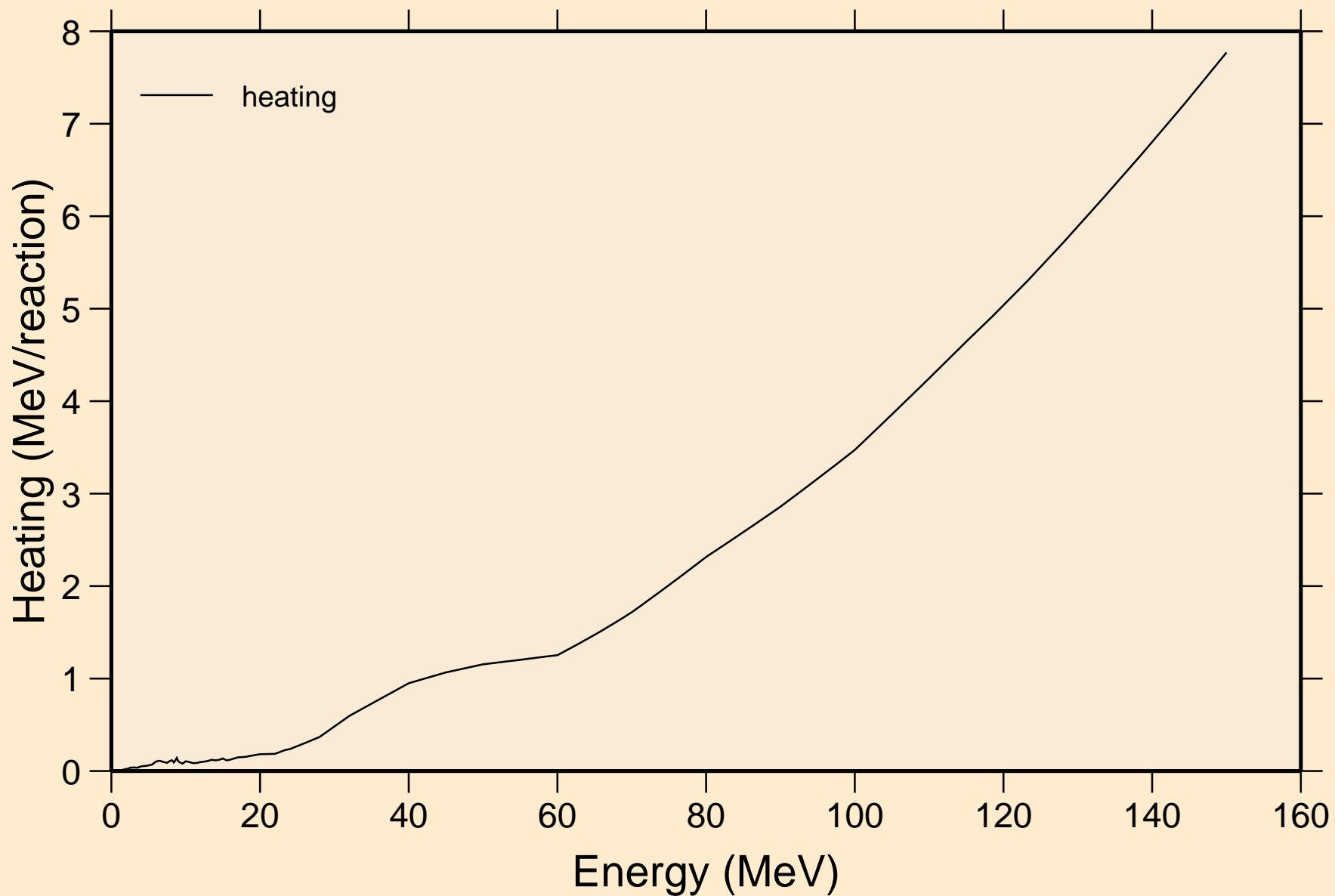

74-W-182 FROM INDL-2008 WITH NJOY99.259.NEA042, FEB. 200
Damage

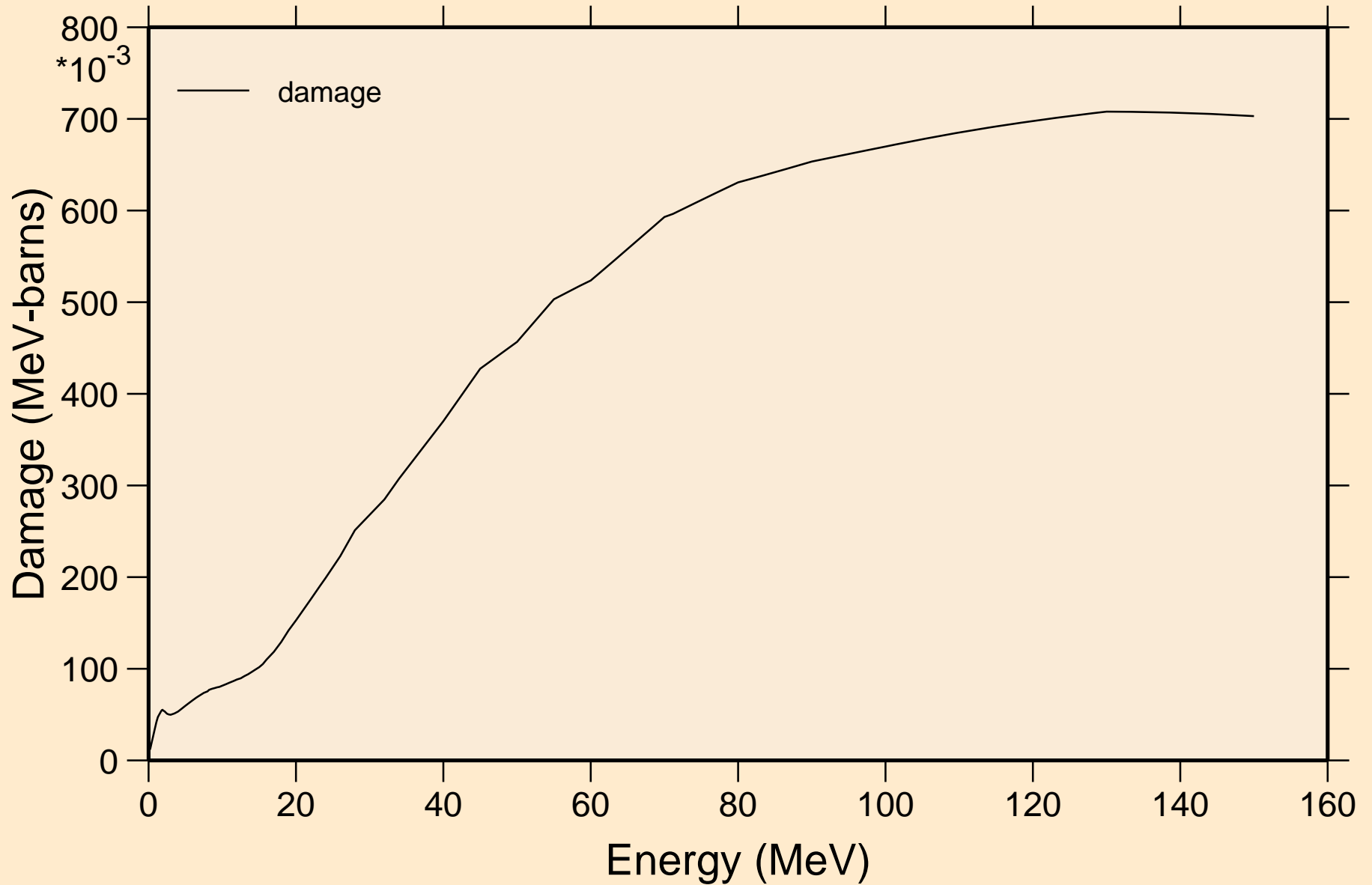

74-W-182 FROM INDL-2008 WITH NJOY99.259.NEA042, FEB. 200
Non-threshold reactions

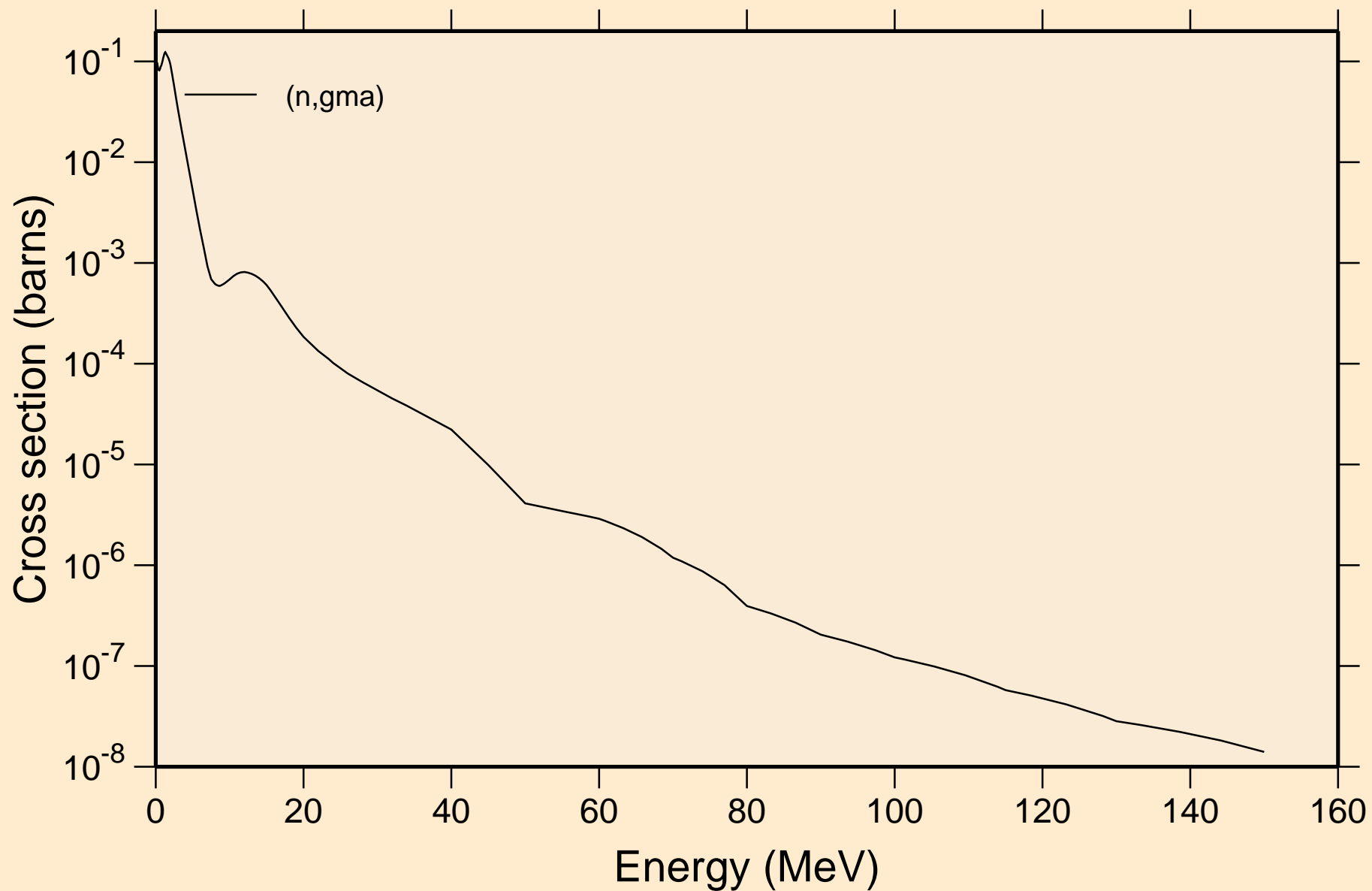

74-W-182 FROM INDL-2008 WITH NJOY99.259.NEA042, FEB. 200
Inelastic levels

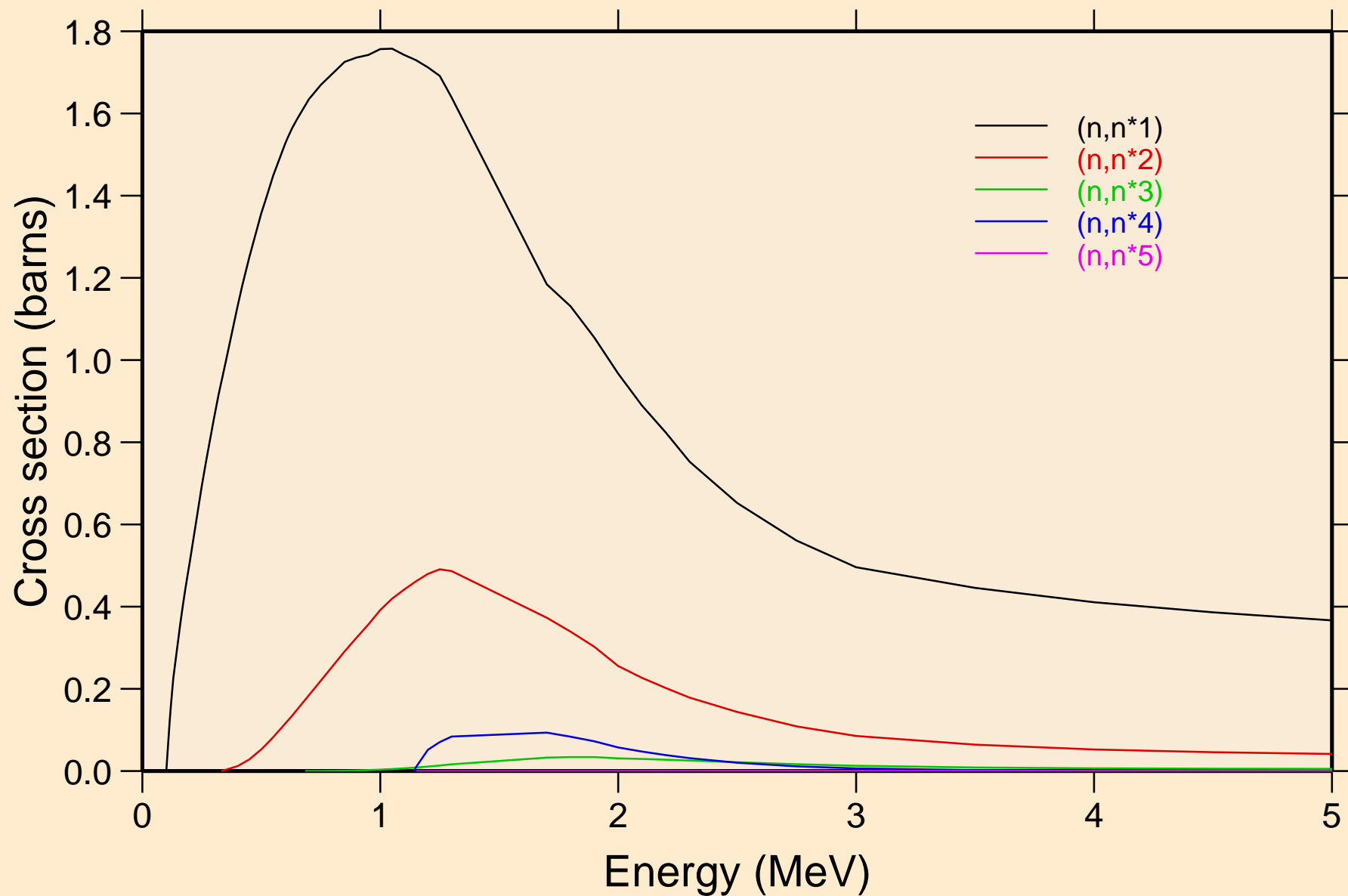

74-W-182 FROM INDL-2008 WITH NJOY99.259.NEA042, FEB. 200
Inelastic levels

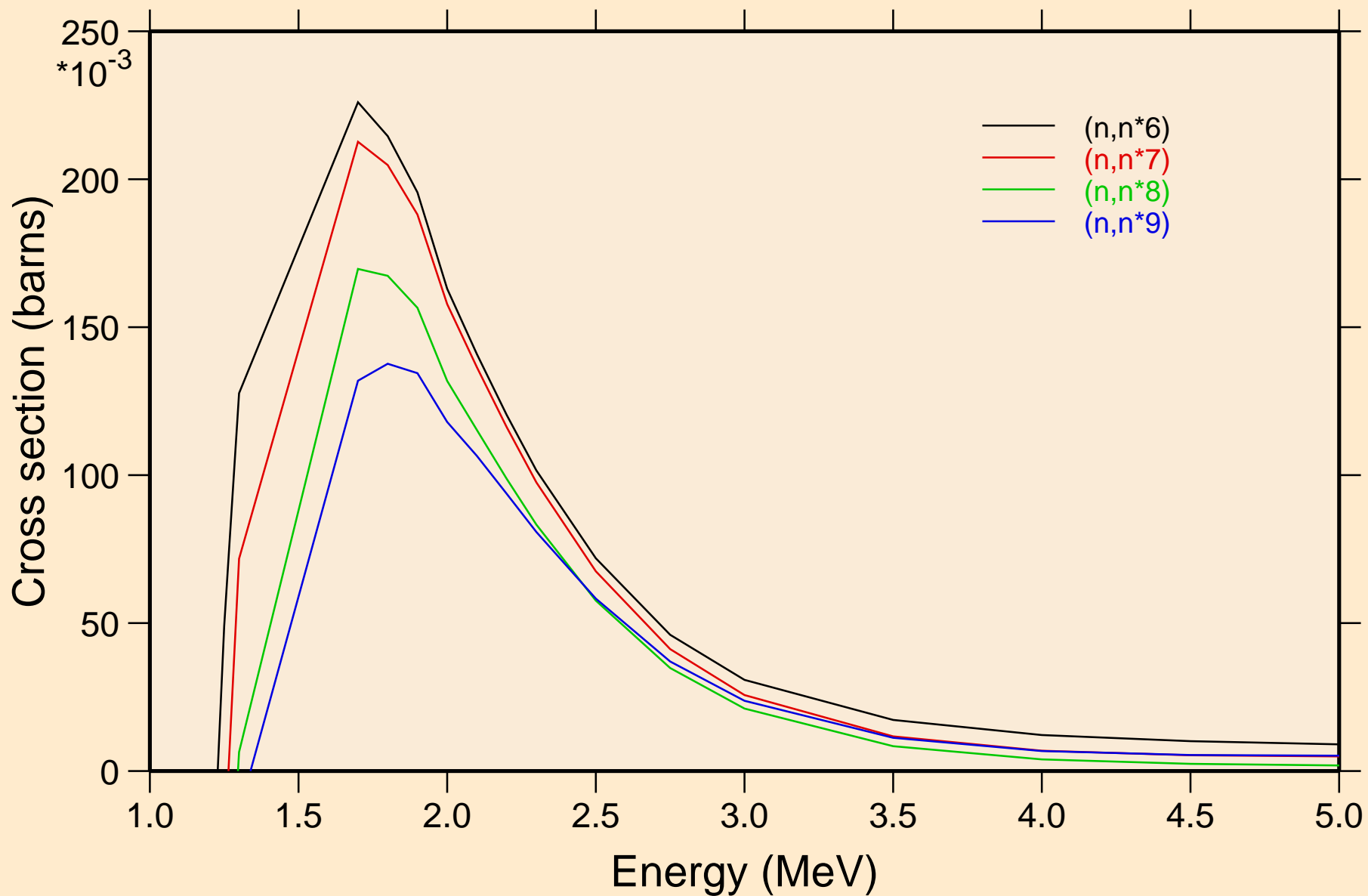

74-W-182 FROM INDL-2008 WITH NJOY99.259.NEA042, FEB. 200
Threshold reactions

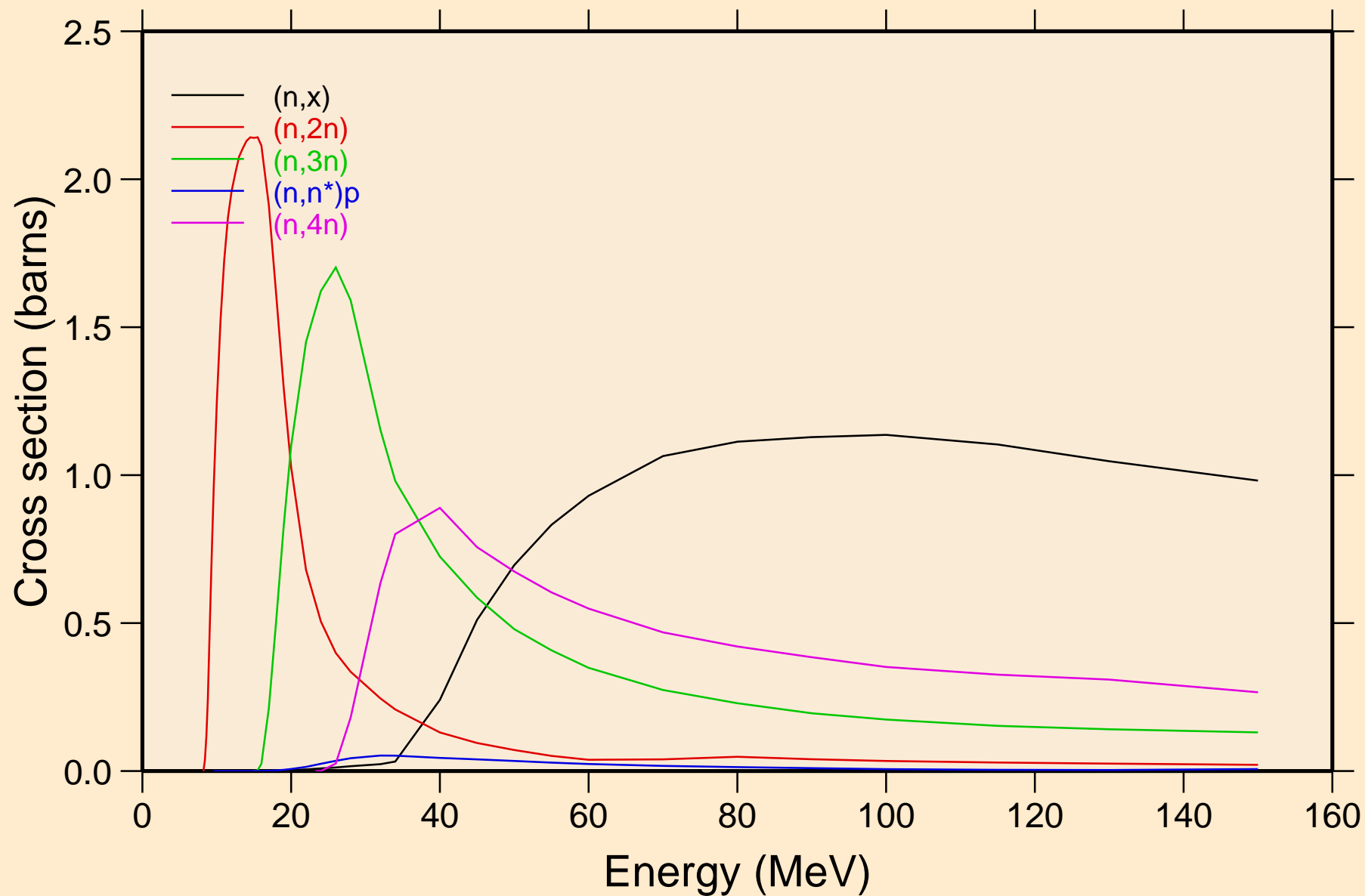

74-W-182 FROM INDL-2008 WITH NJOY99.259.NEA042, FEB. 200
Threshold reactions

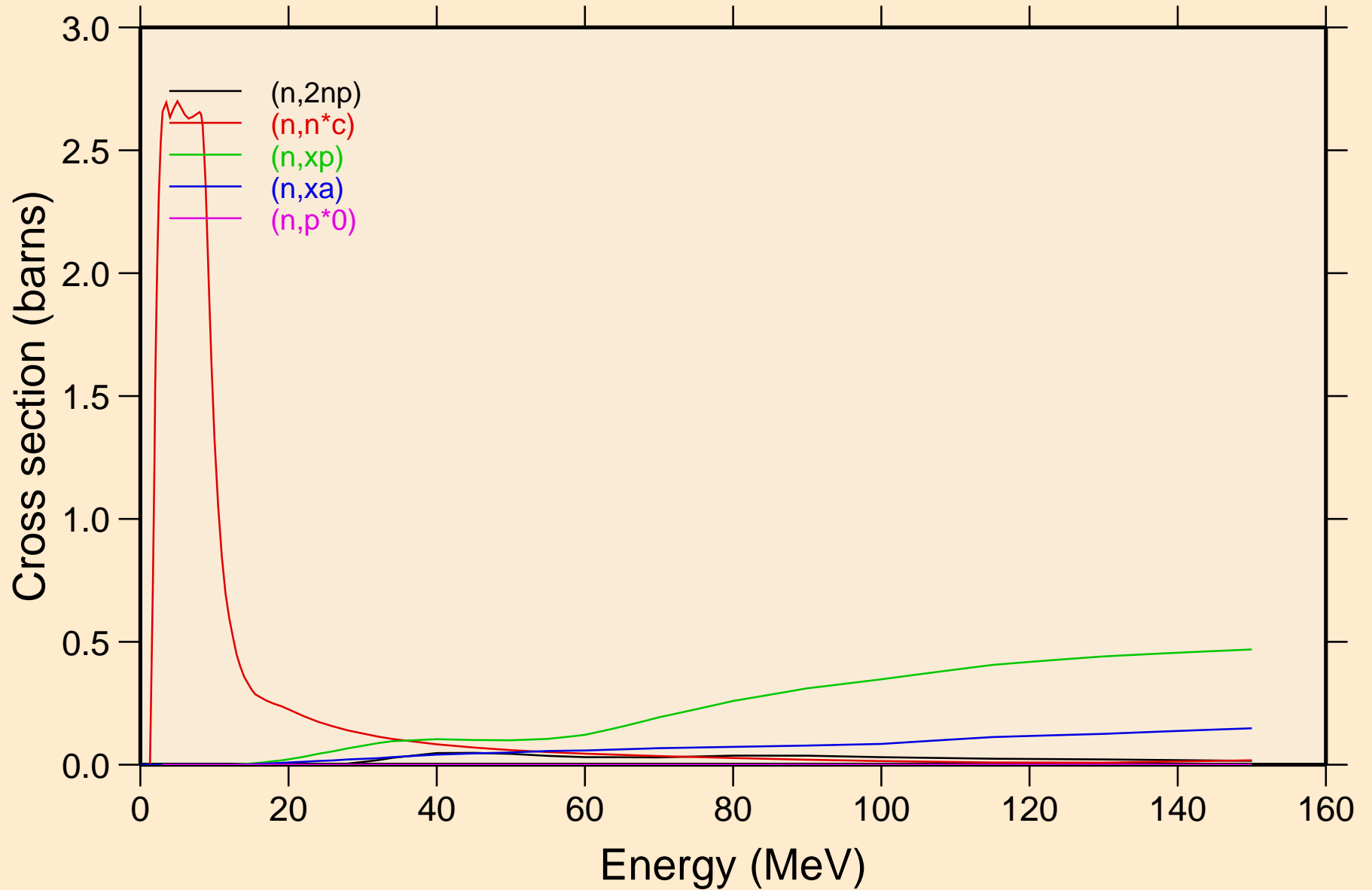

74-W-182 FROM INDL-2008 WITH NJOY99.259.NEA042, FEB. 200
Threshold reactions

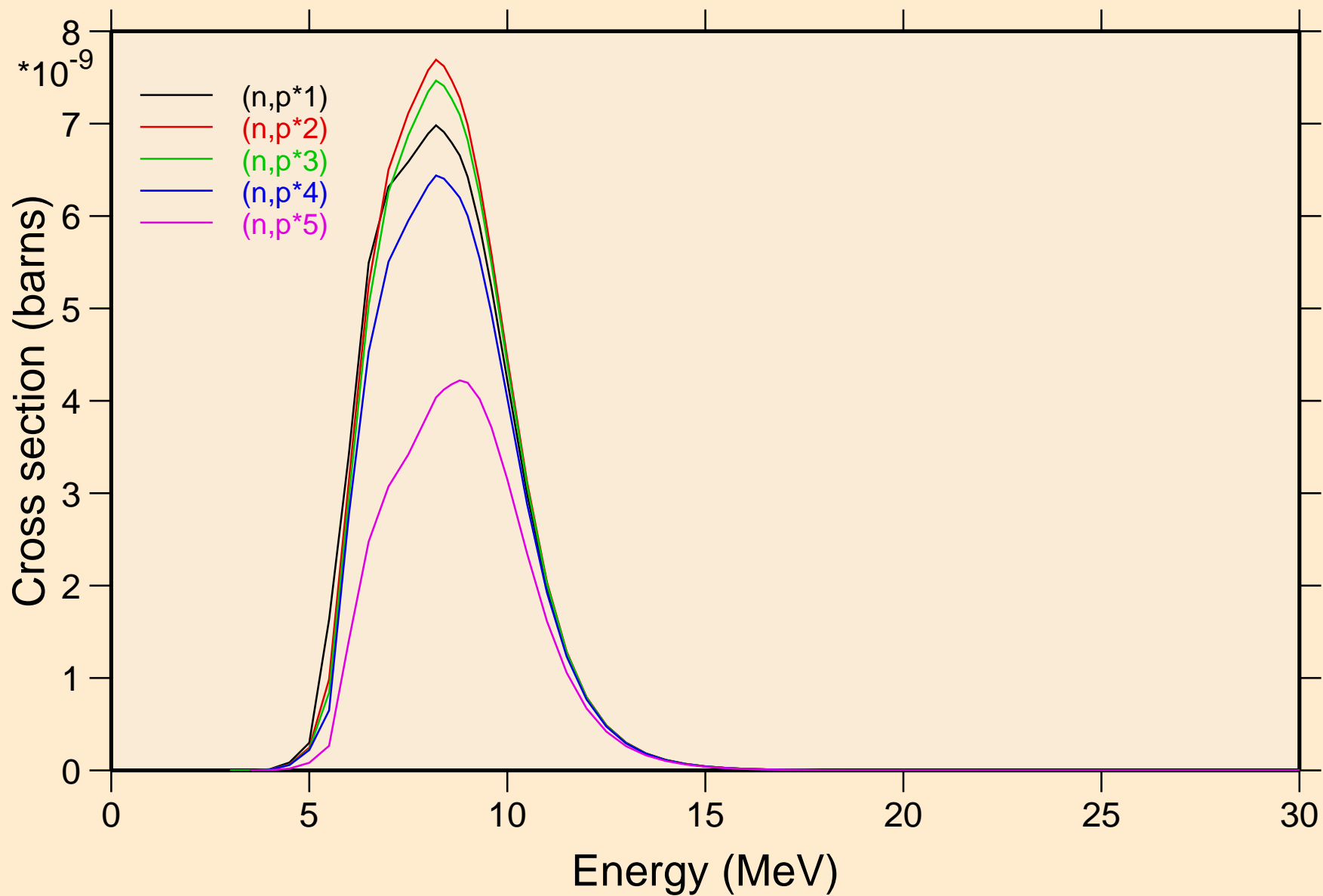

74-W-182 FROM INDL-2008 WITH NJOY99.259.NEA042, FEB. 200
Threshold reactions

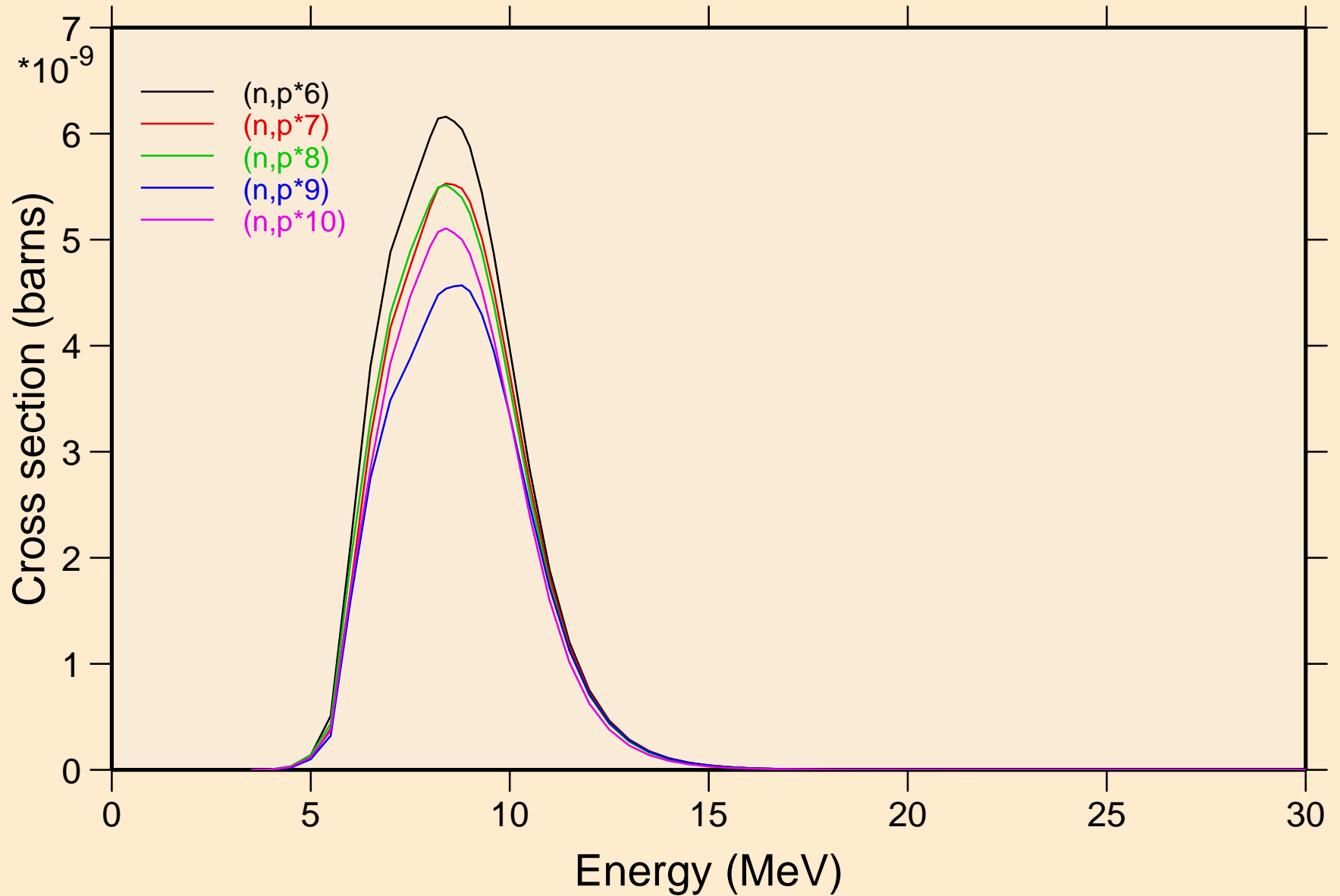

74-W-182 FROM INDL-2008 WITH NJOY99.259.NEA042, FEB. 200
Threshold reactions

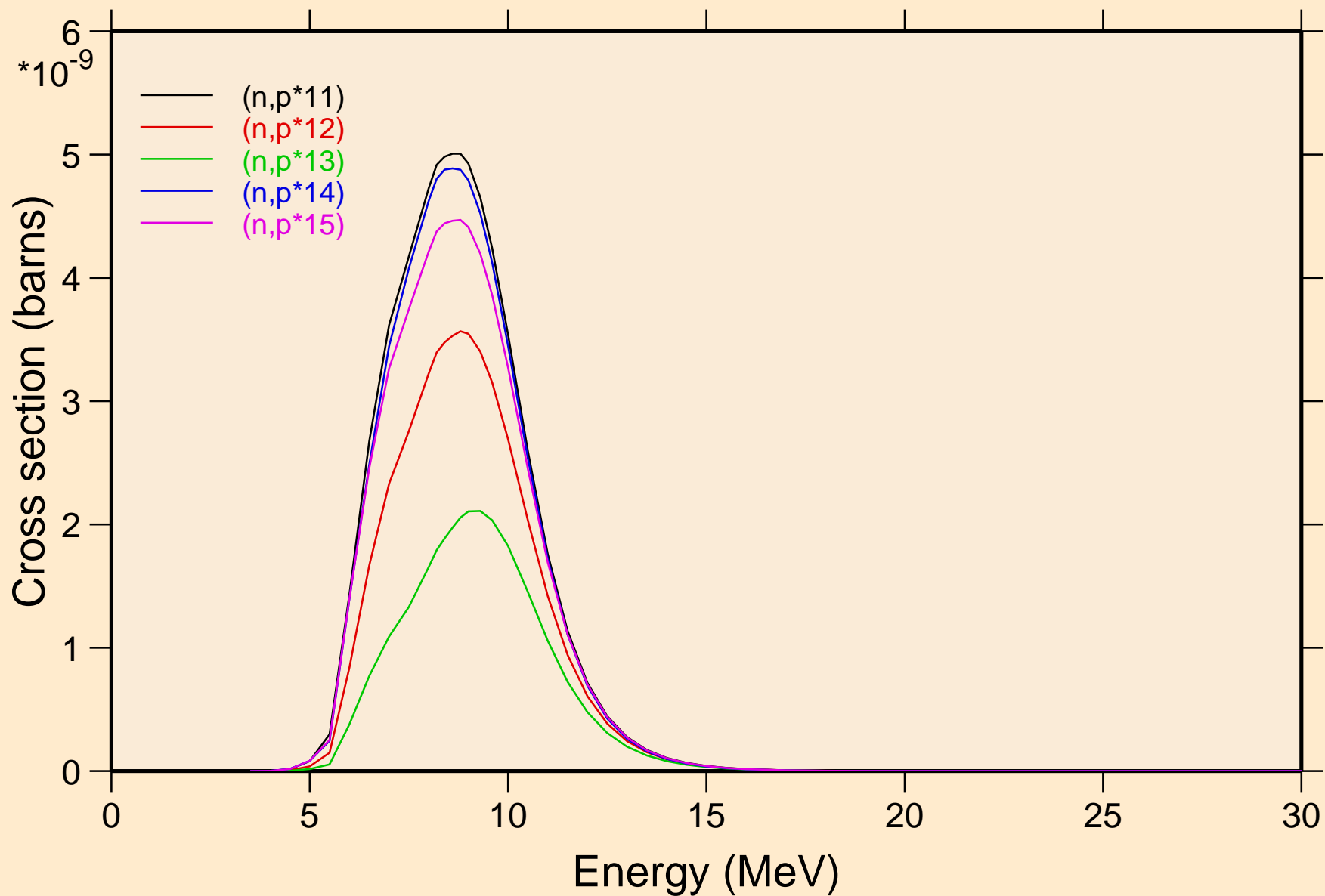

74-W-182 FROM INDL-2008 WITH NJOY99.259.NEA042, FEB. 200
Threshold reactions

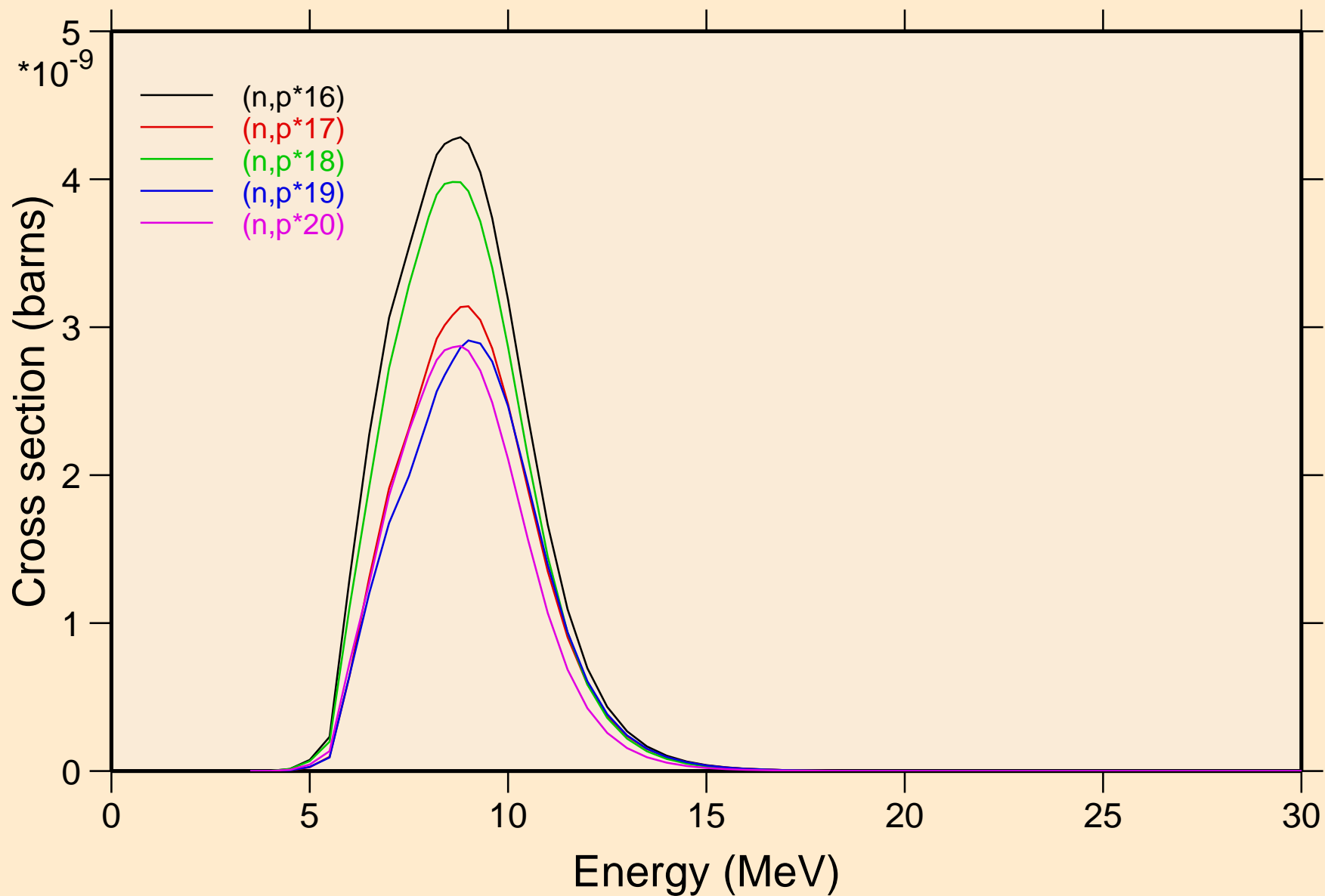

74-W-182 FROM INDL-2008 WITH NJOY99.259.NEA042, FEB. 200
Threshold reactions

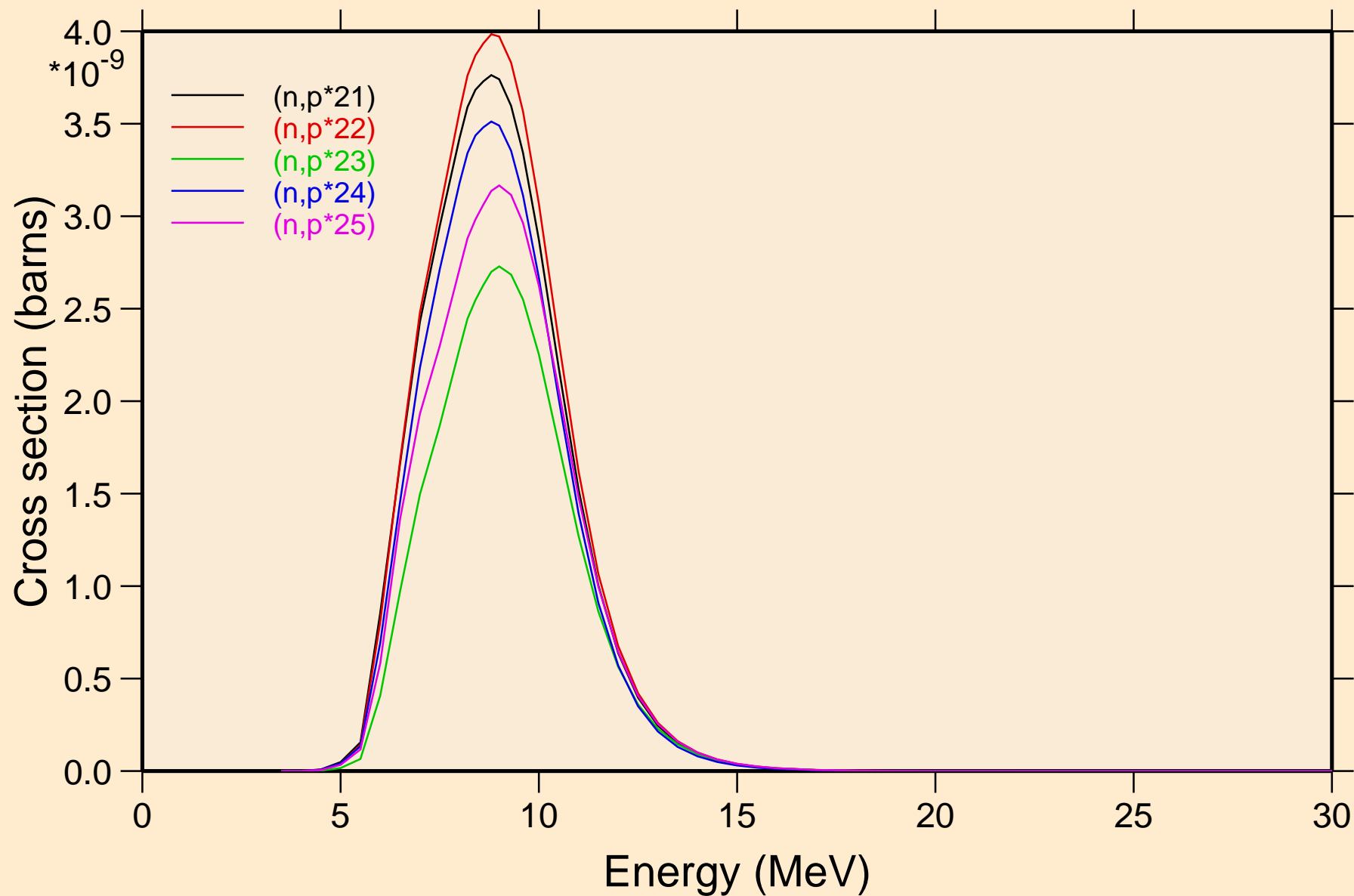

74-W-182 FROM INDL-2008 WITH NJOY99.259.NEA042, FEB. 200
Threshold reactions

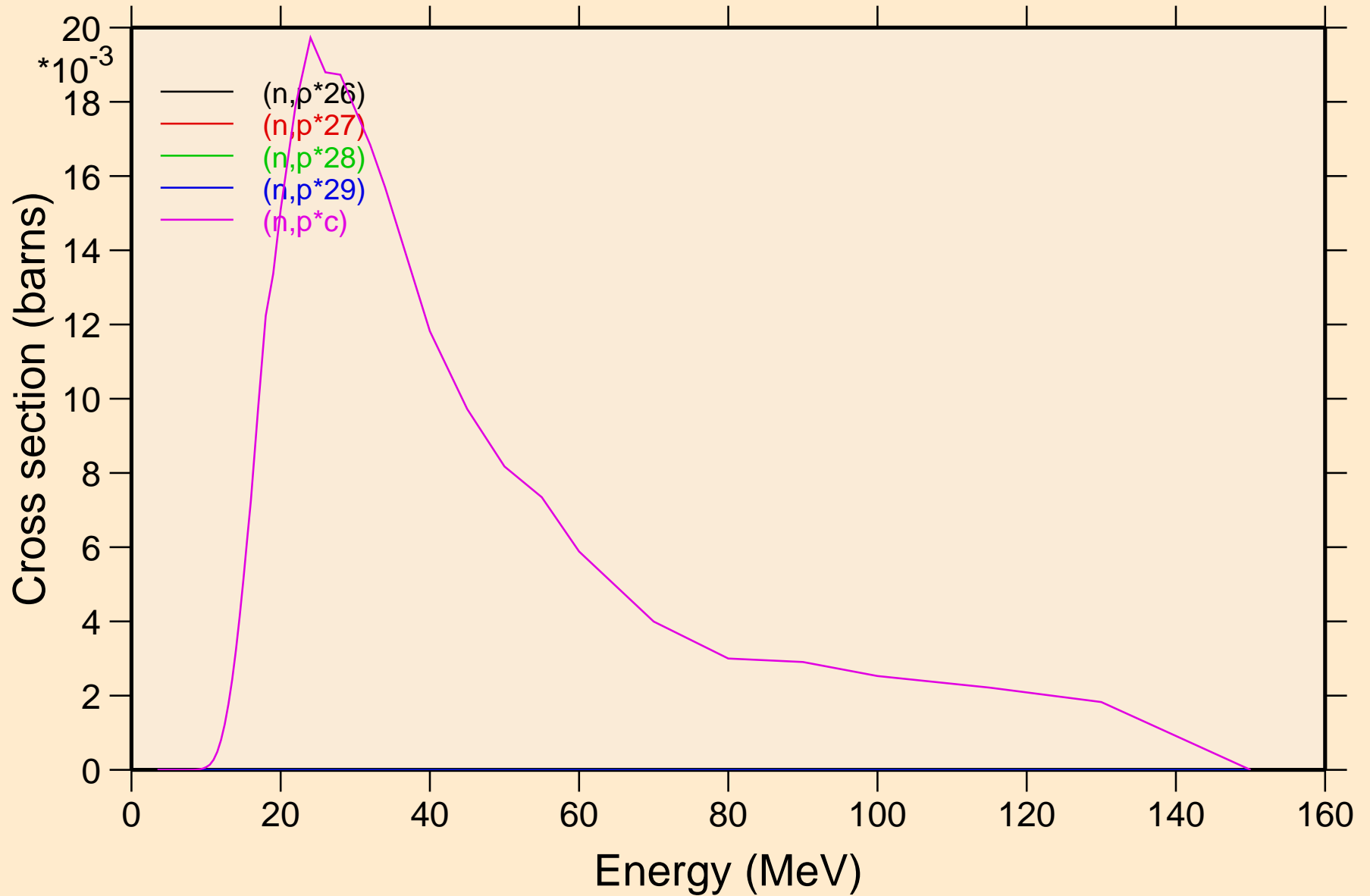

74-W-182 FROM INDL-2008 WITH NJOY99.259.NEA042, FEB. 200
Threshold reactions

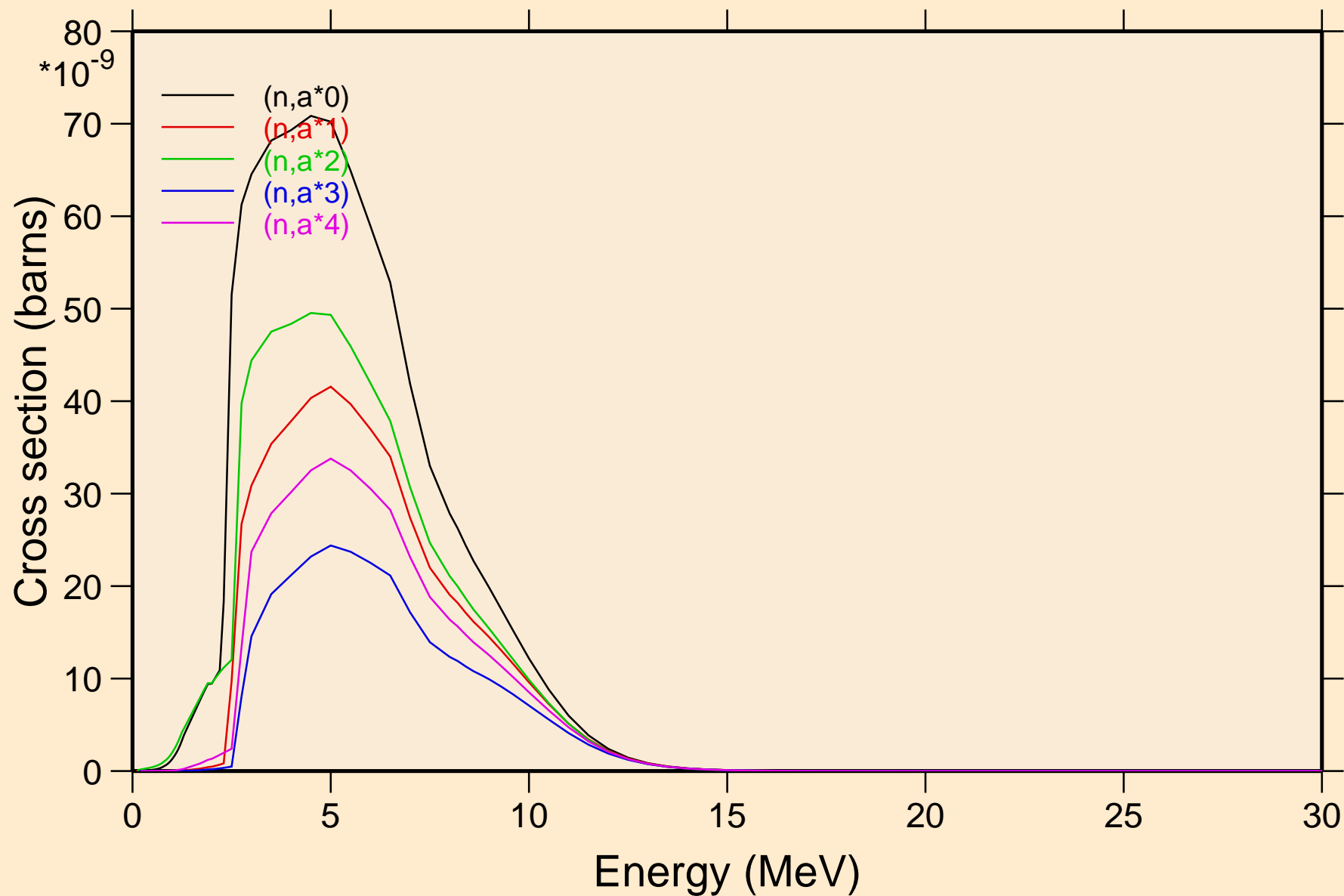

74-W-182 FROM INDL-2008 WITH NJOY99.259.NEA042, FEB. 200
Threshold reactions

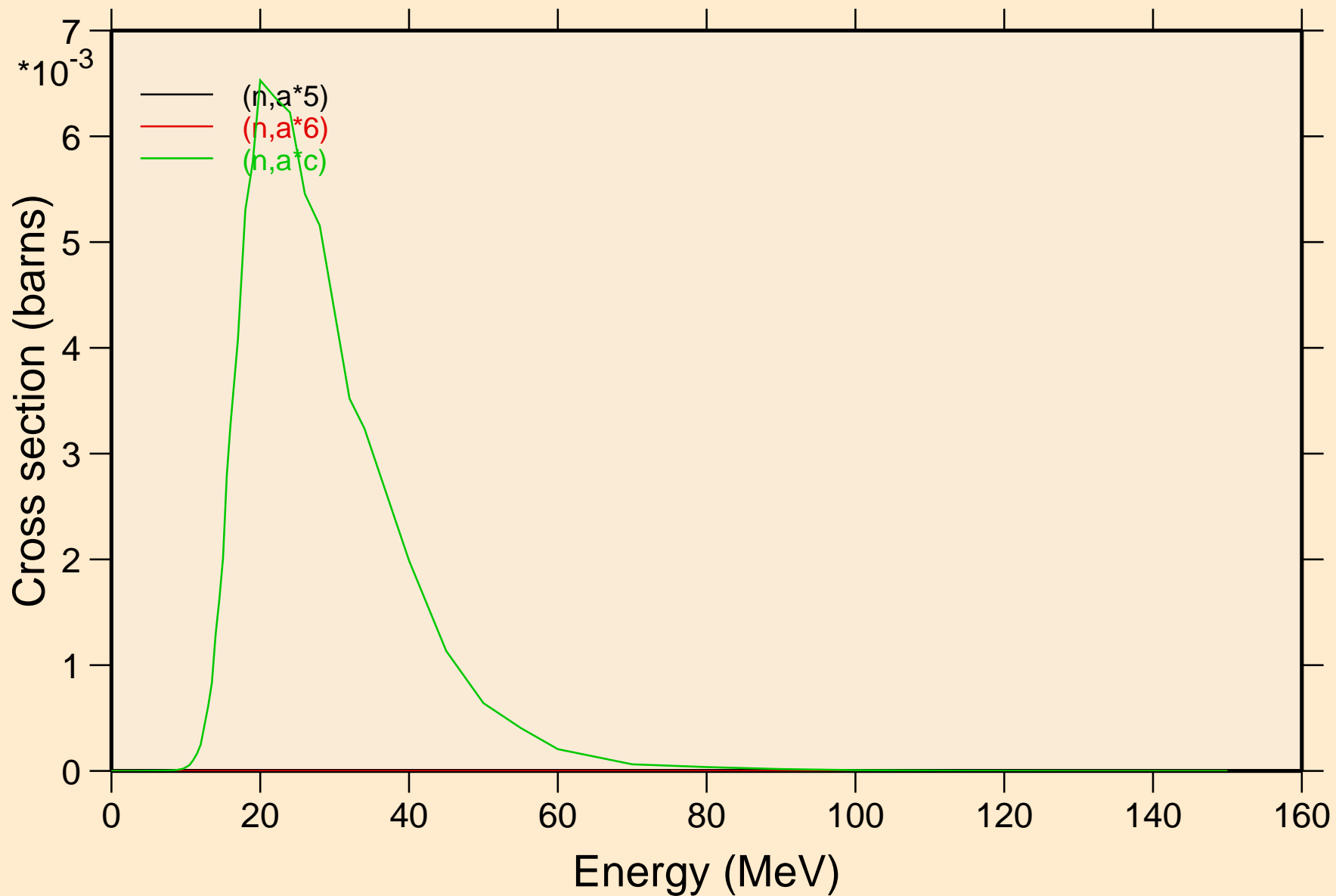

74-W-182 FROM INDL-2008 WITH NJOY99.259.NEA042, FEB. 200
angular distribution for elastic

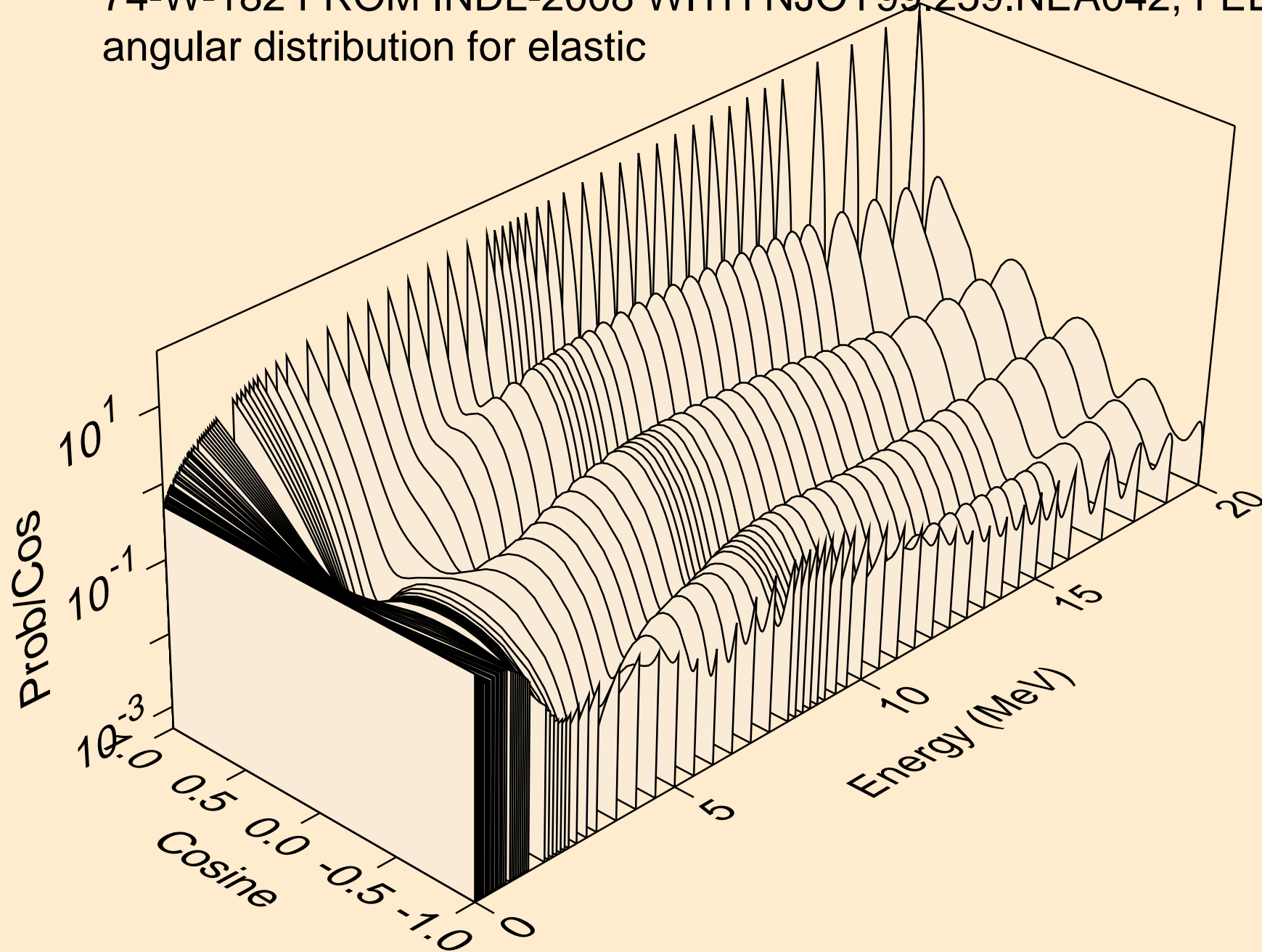

74-W-182 FROM INDL-2008 WITH NJOY99.259.NEA042, FEB. 200
angular distribution for elastic

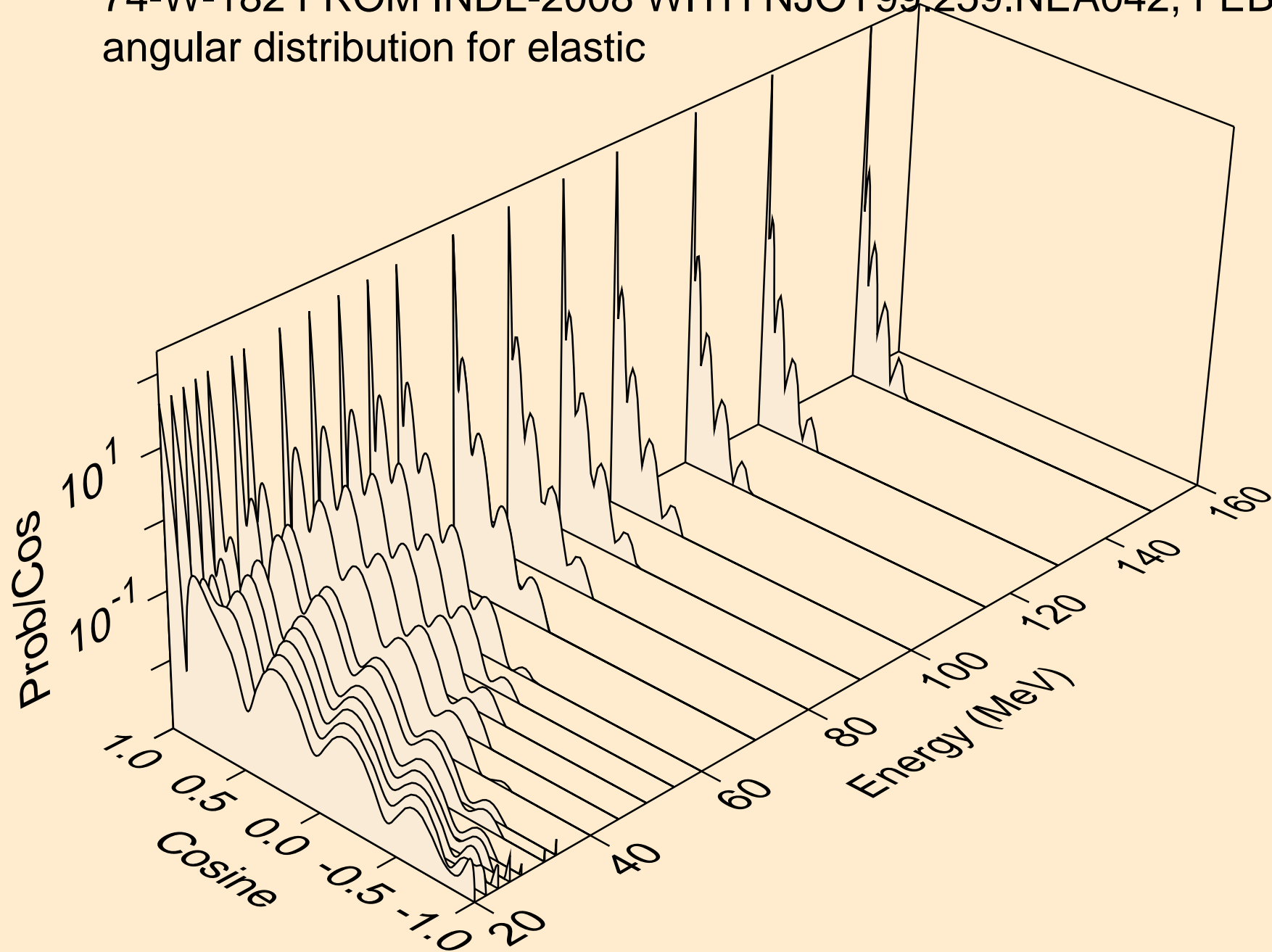

74-W-182 FROM INDL-2008 WITH NJOY99.259.NEA042, FEB. 200
angular distribution for (n,n*1)

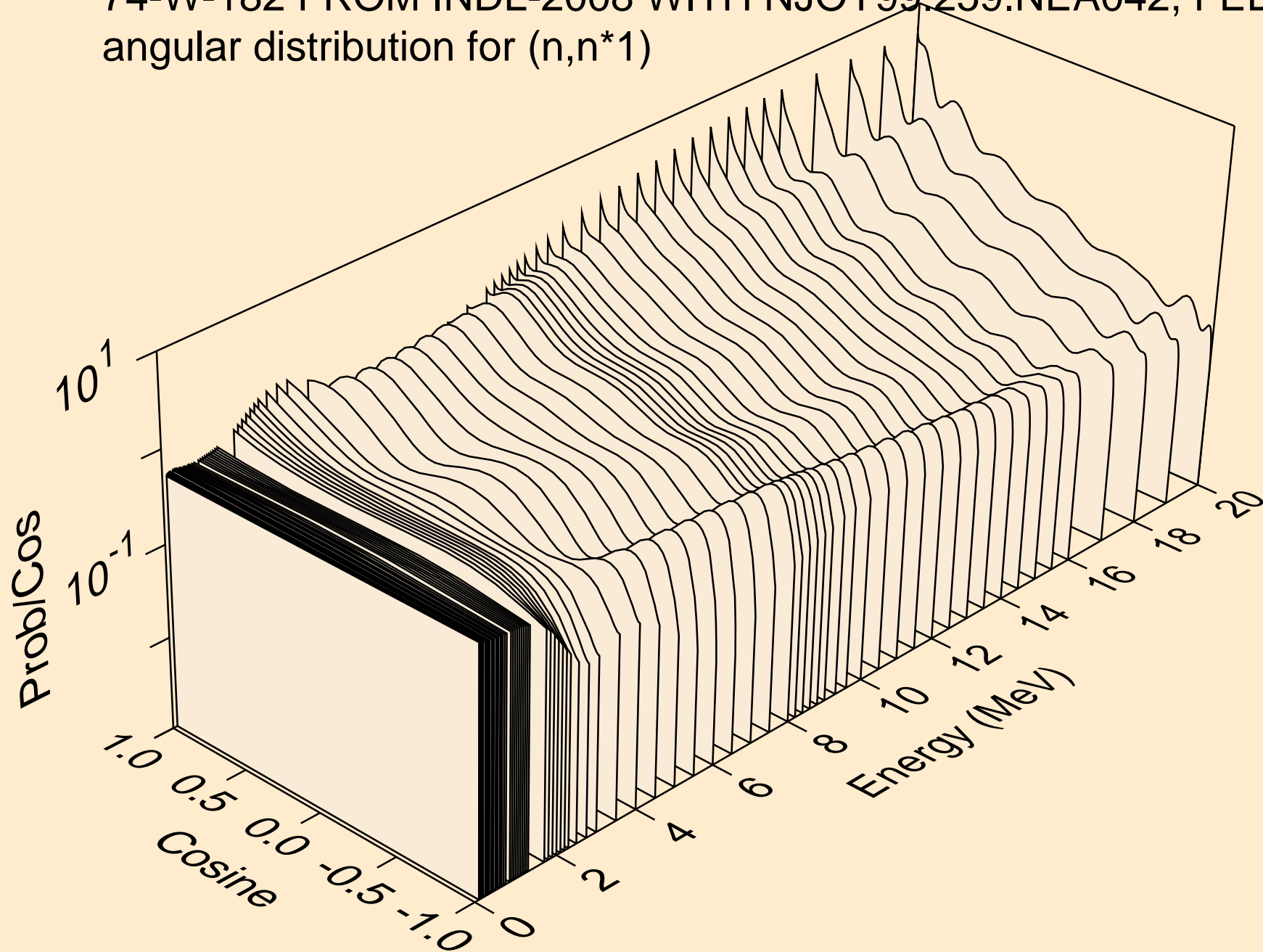

74-W-182 FROM INDL-2008 WITH NJOY99.259.NEA042, FEB. 200
angular distribution for (n,n*1)

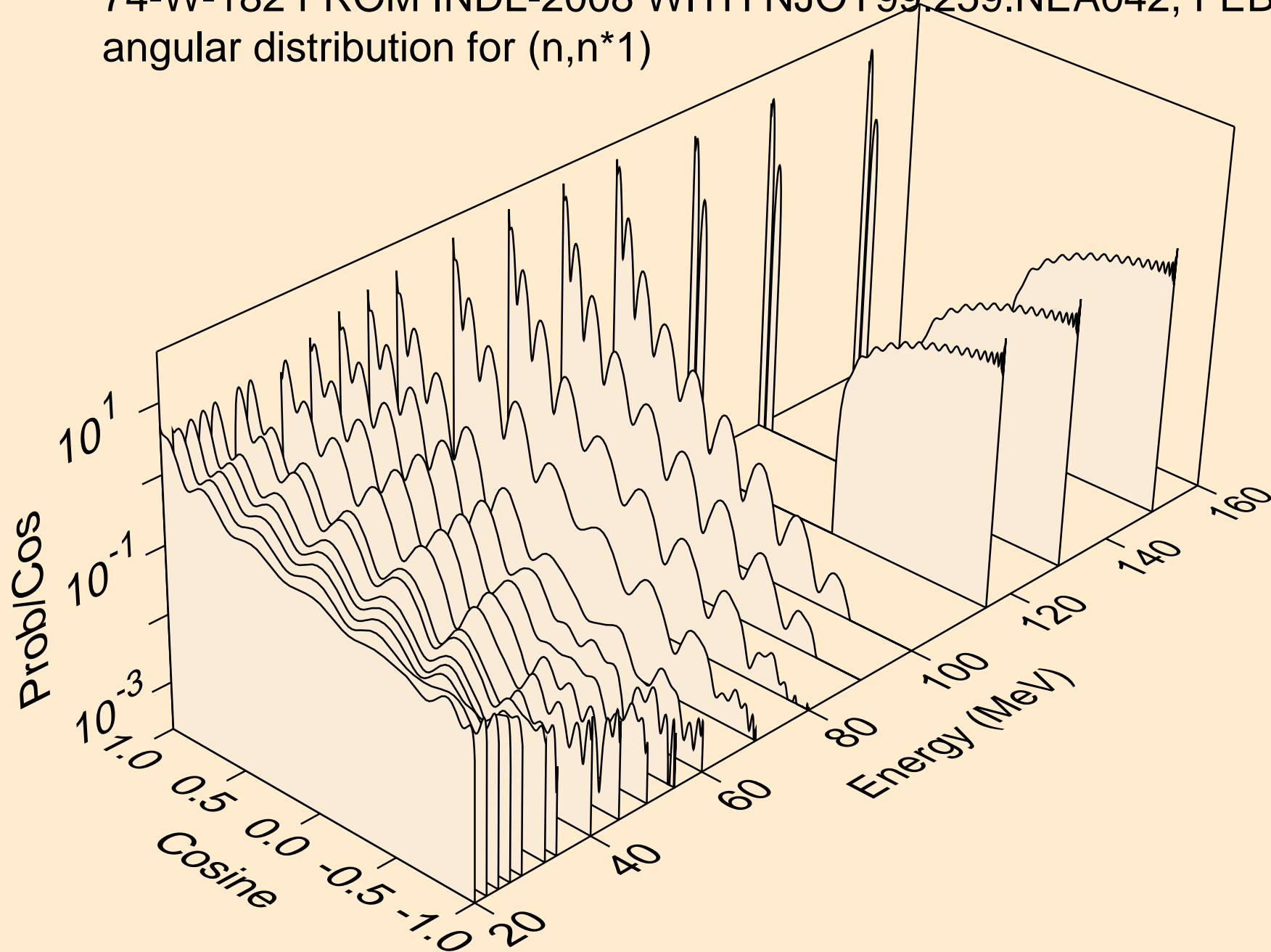

74-W-182 FROM INDL-2008 WITH NJOY99.259.NEA042, FEB. 200
angular distribution for (n,n*2)

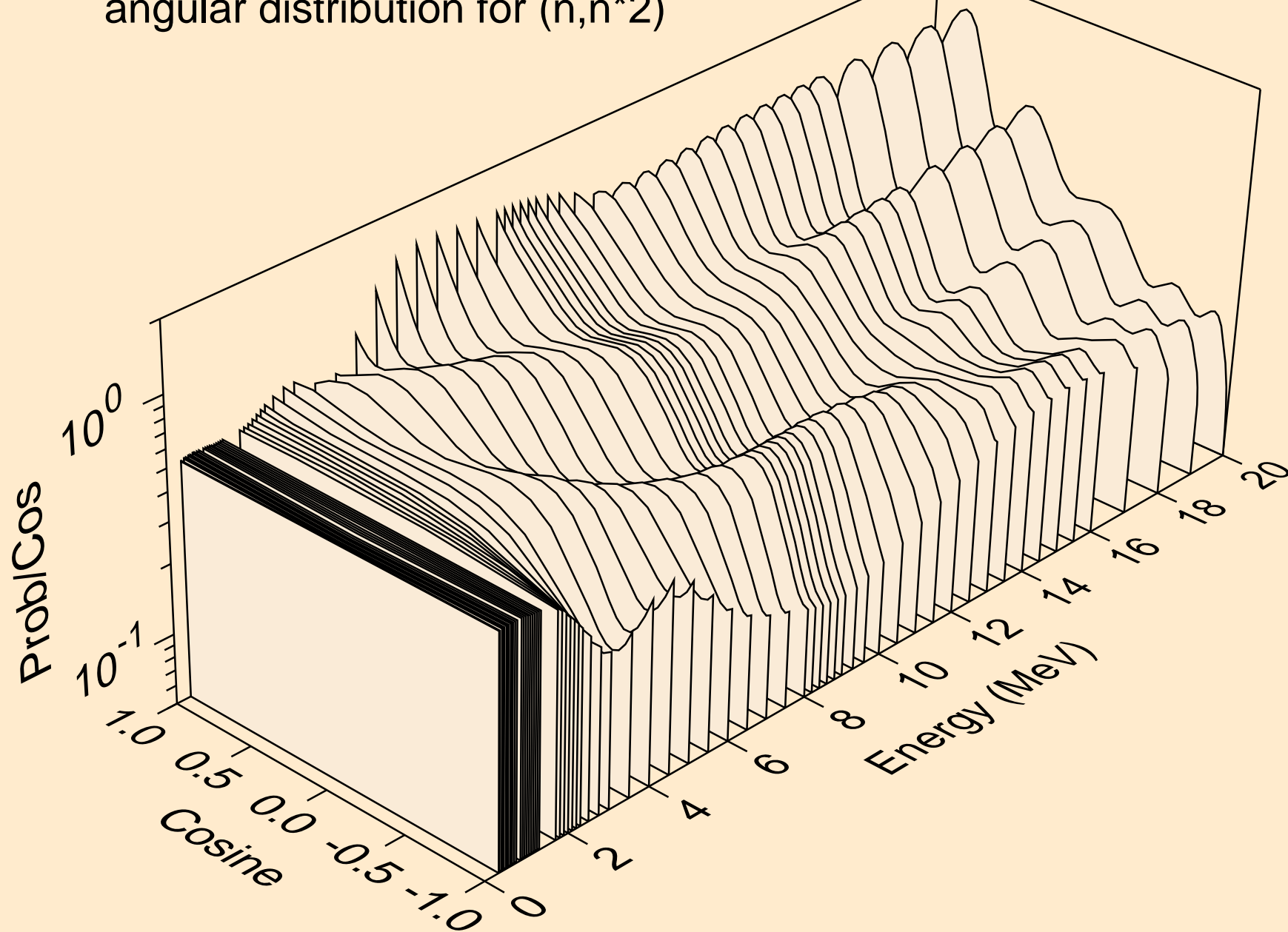

74-W-182 FROM INDL-2008 WITH NJOY99.259.NEA042, FEB. 200
angular distribution for (n,n*2)

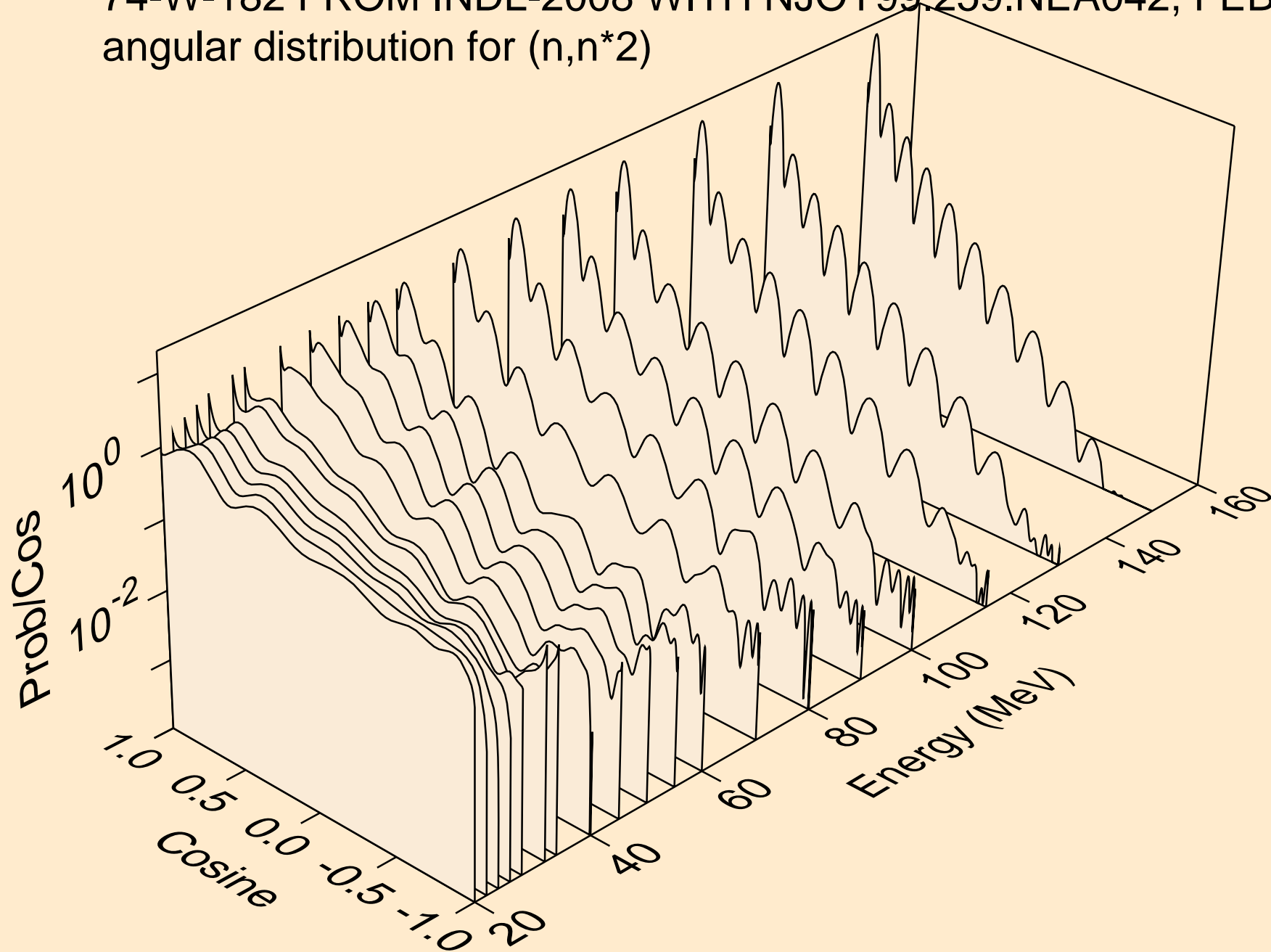

74-W-182 FROM INDL-2008 WITH NJOY99.259.NEA042, FEB. 2000
angular distribution for (n,n*3)

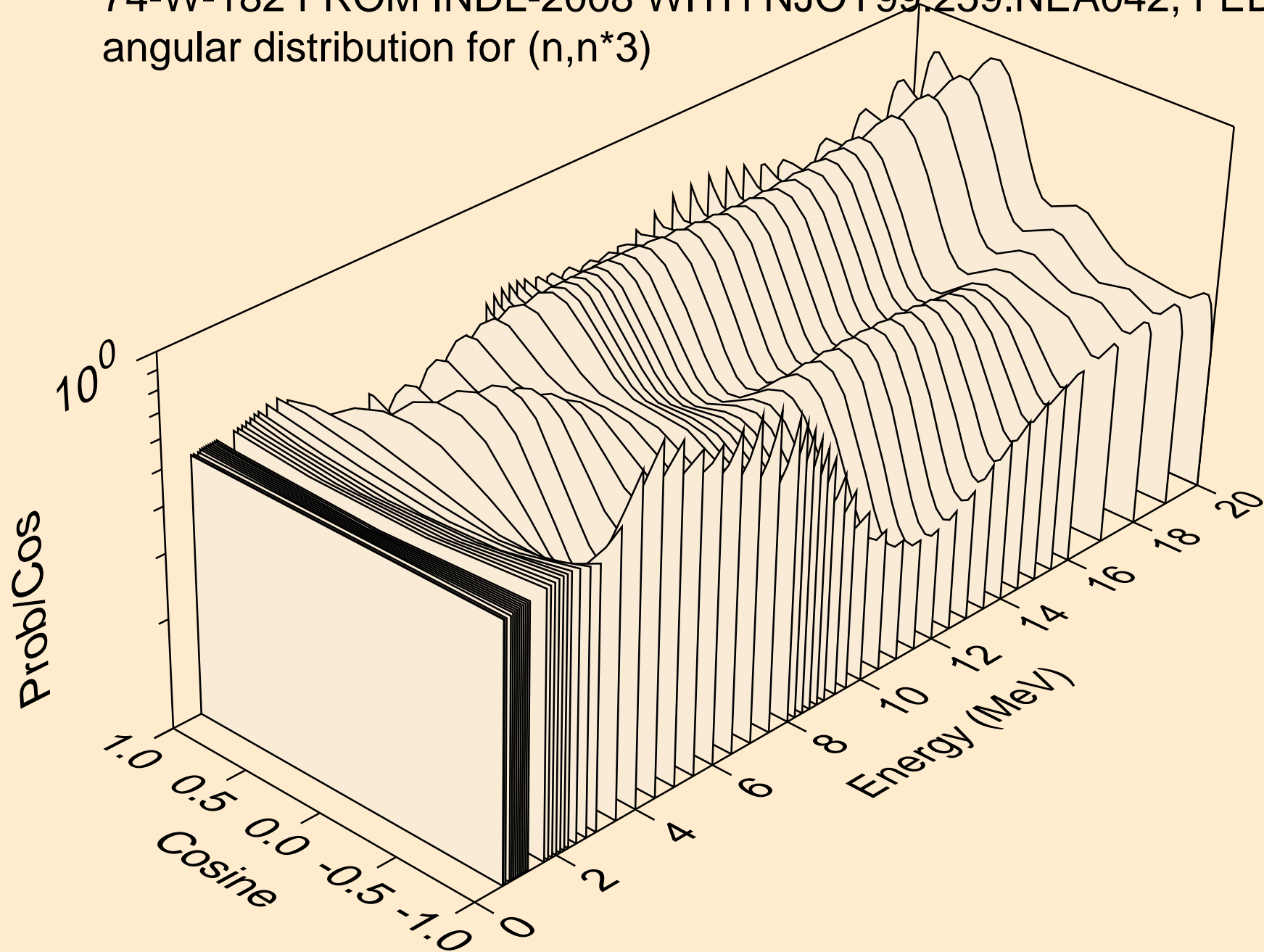

74-W-182 FROM INDL-2008 WITH NJOY99.259.NEA042, FEB. 200
angular distribution for (n,n*3)

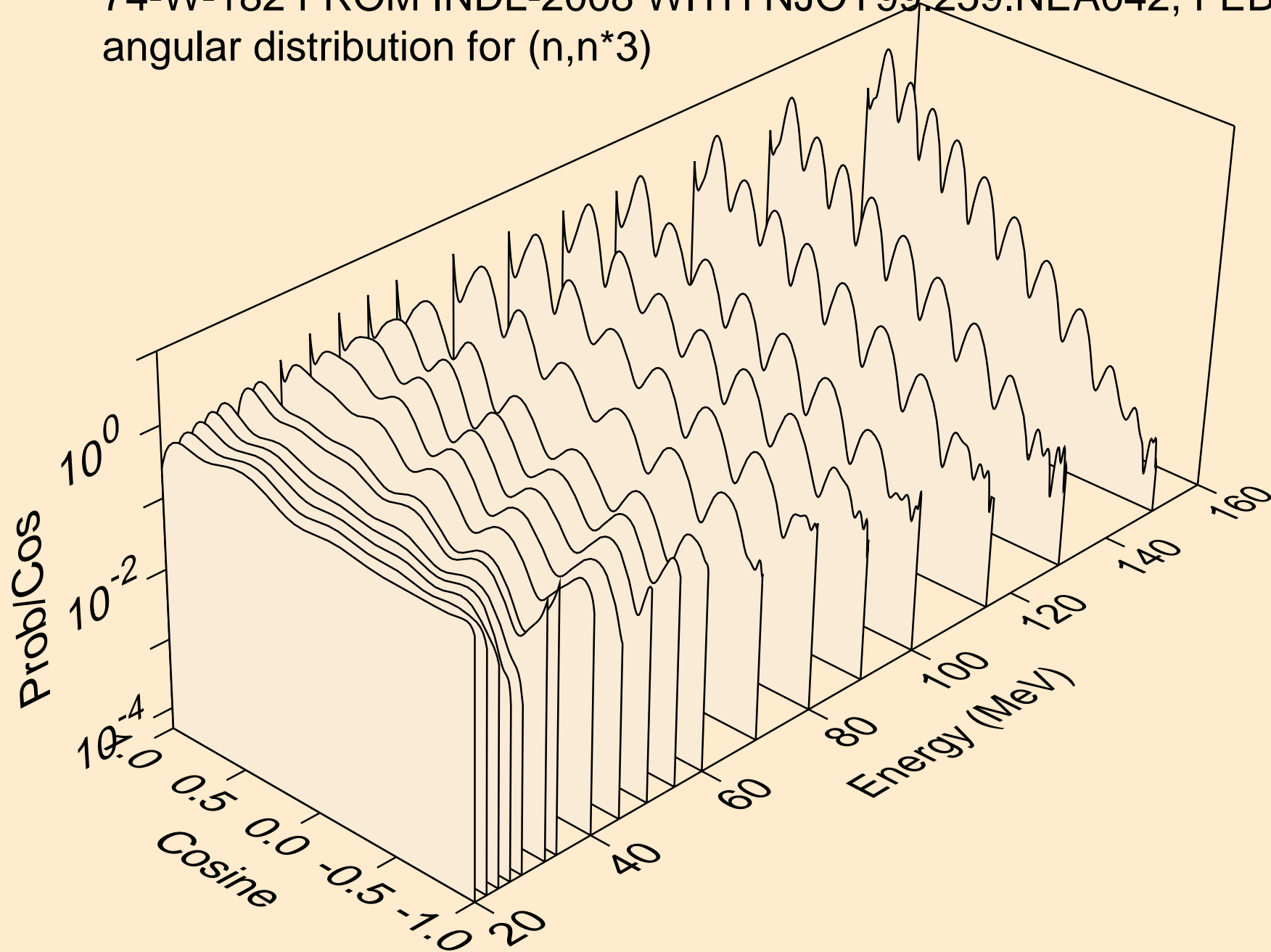

74-W-182 FROM INDL-2008 WITH NJOY99.259.NEA042, FEB. 200
angular distribution for (n,n*4)

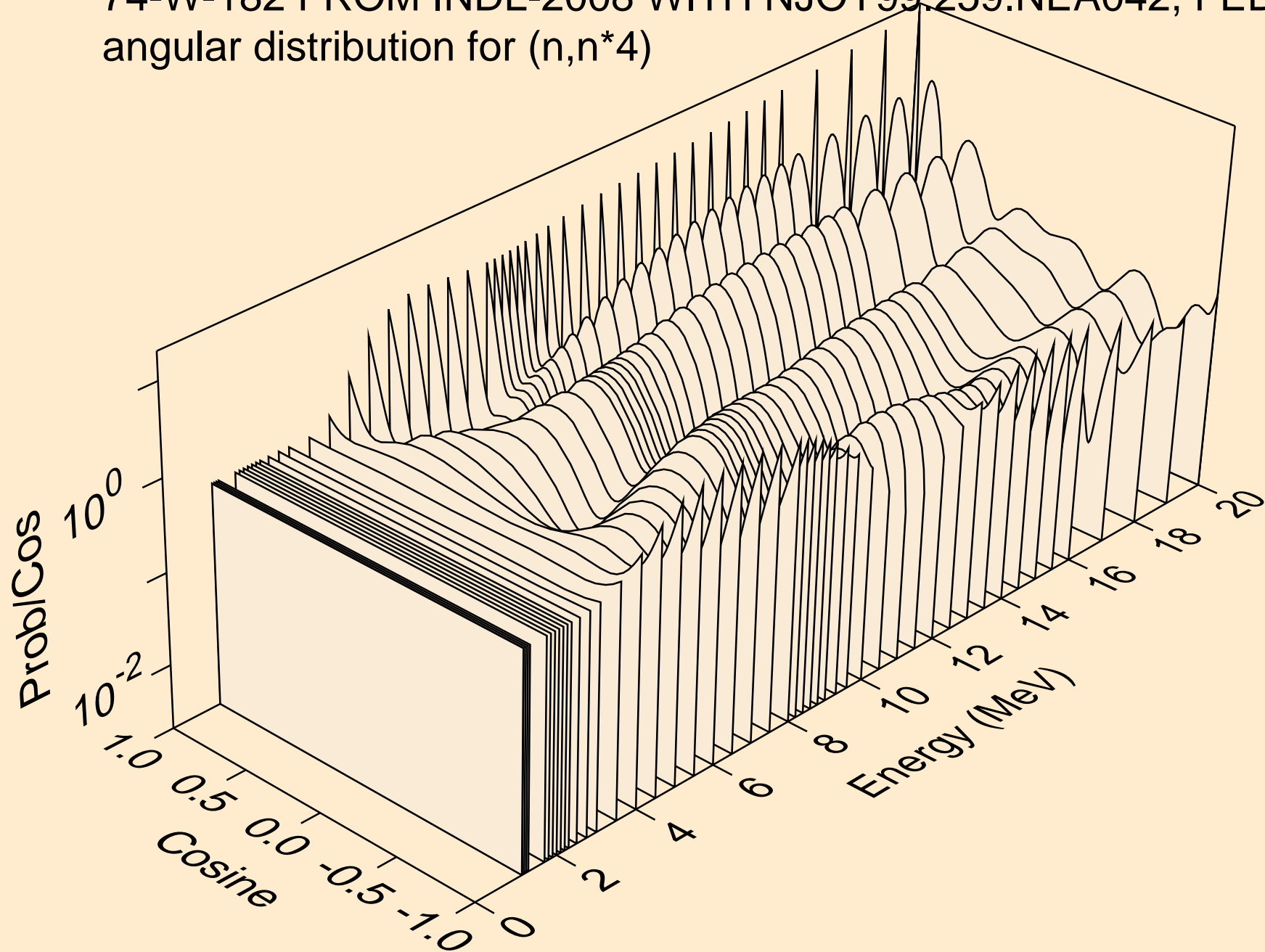

74-W-182 FROM INDL-2008 WITH NJOY99.259.NEA042, FEB. 200
angular distribution for (n,n*4)

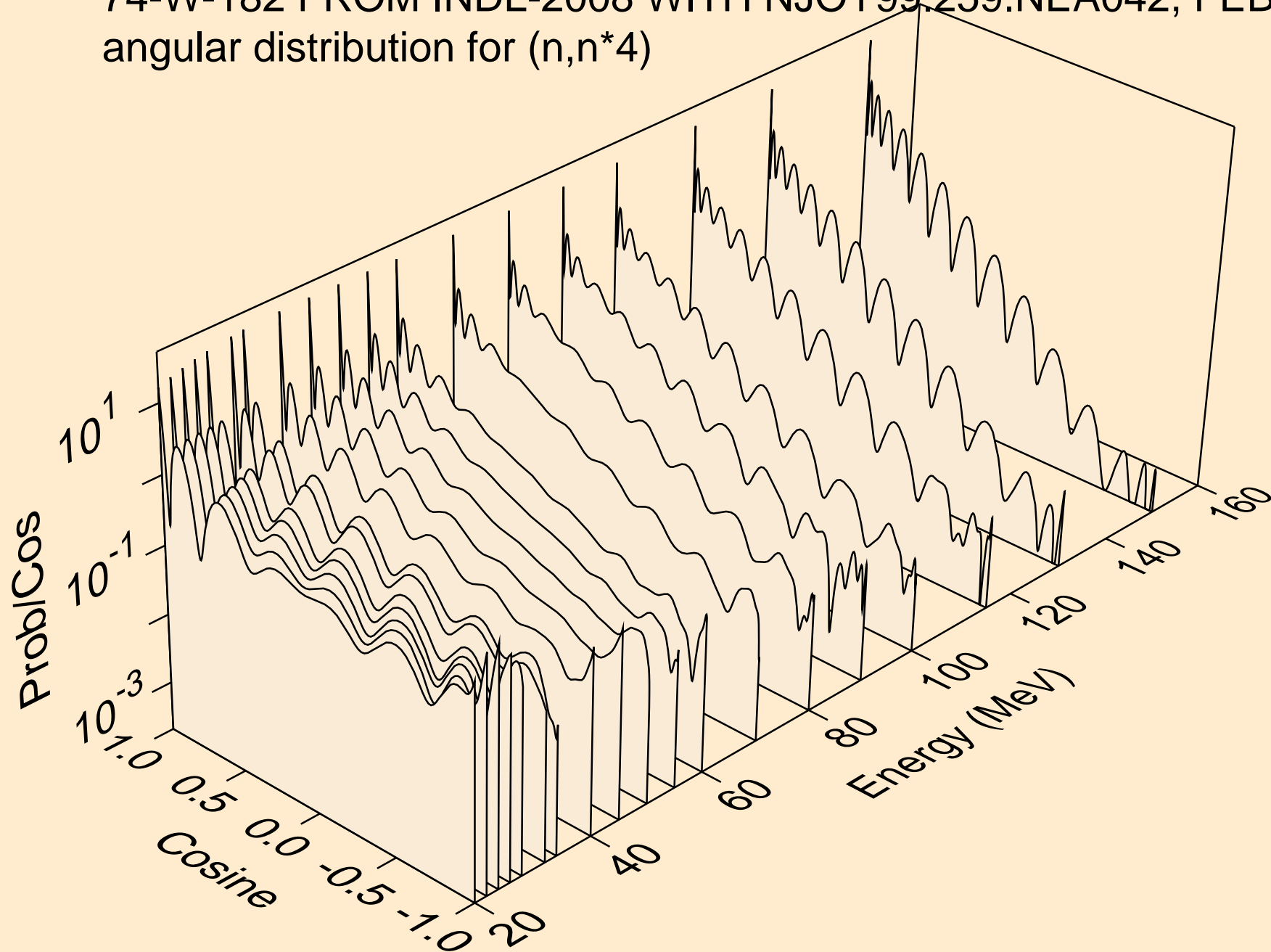

74-W-182 FROM INDL-2008 WITH NJOY99.259.NEA042, FEB. 200
angular distribution for (n,n*5)

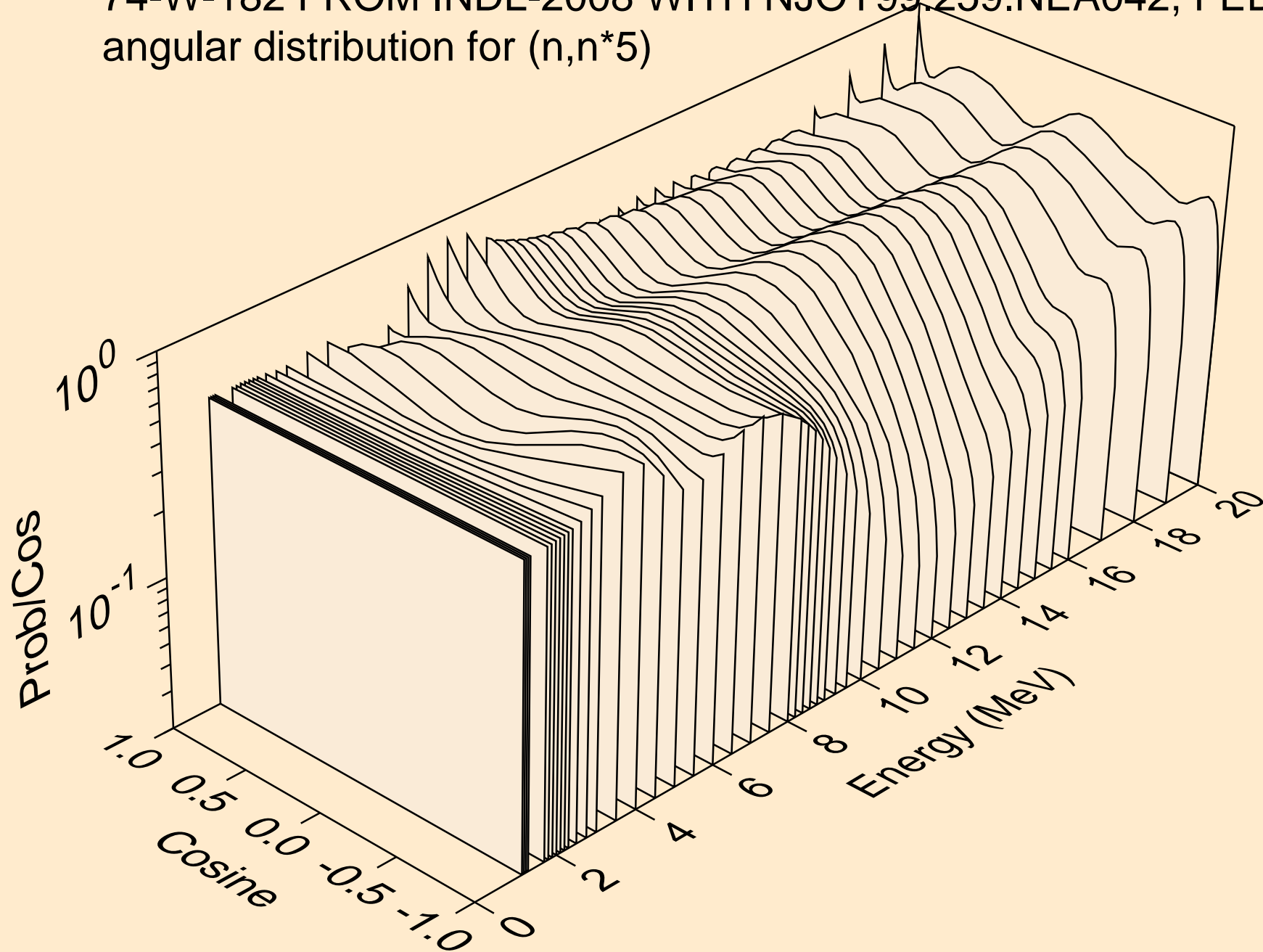

74-W-182 FROM INDL-2008 WITH NJOY99.259.NEA042, FEB. 200
angular distribution for (n,n*5)

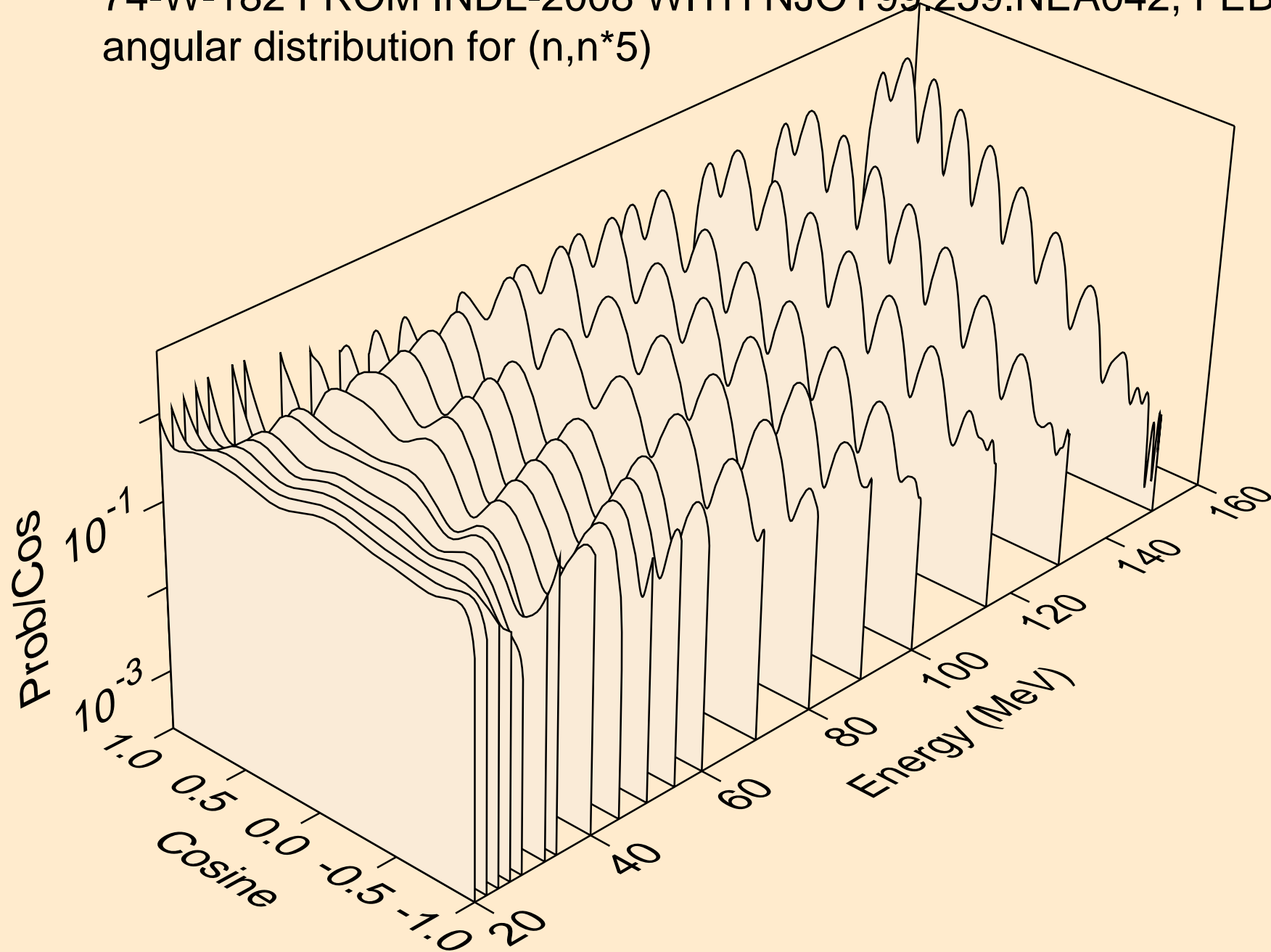

74-W-182 FROM INDL-2008 WITH NJOY99.259.NEA042, FEB. 200
angular distribution for (n,n*6)

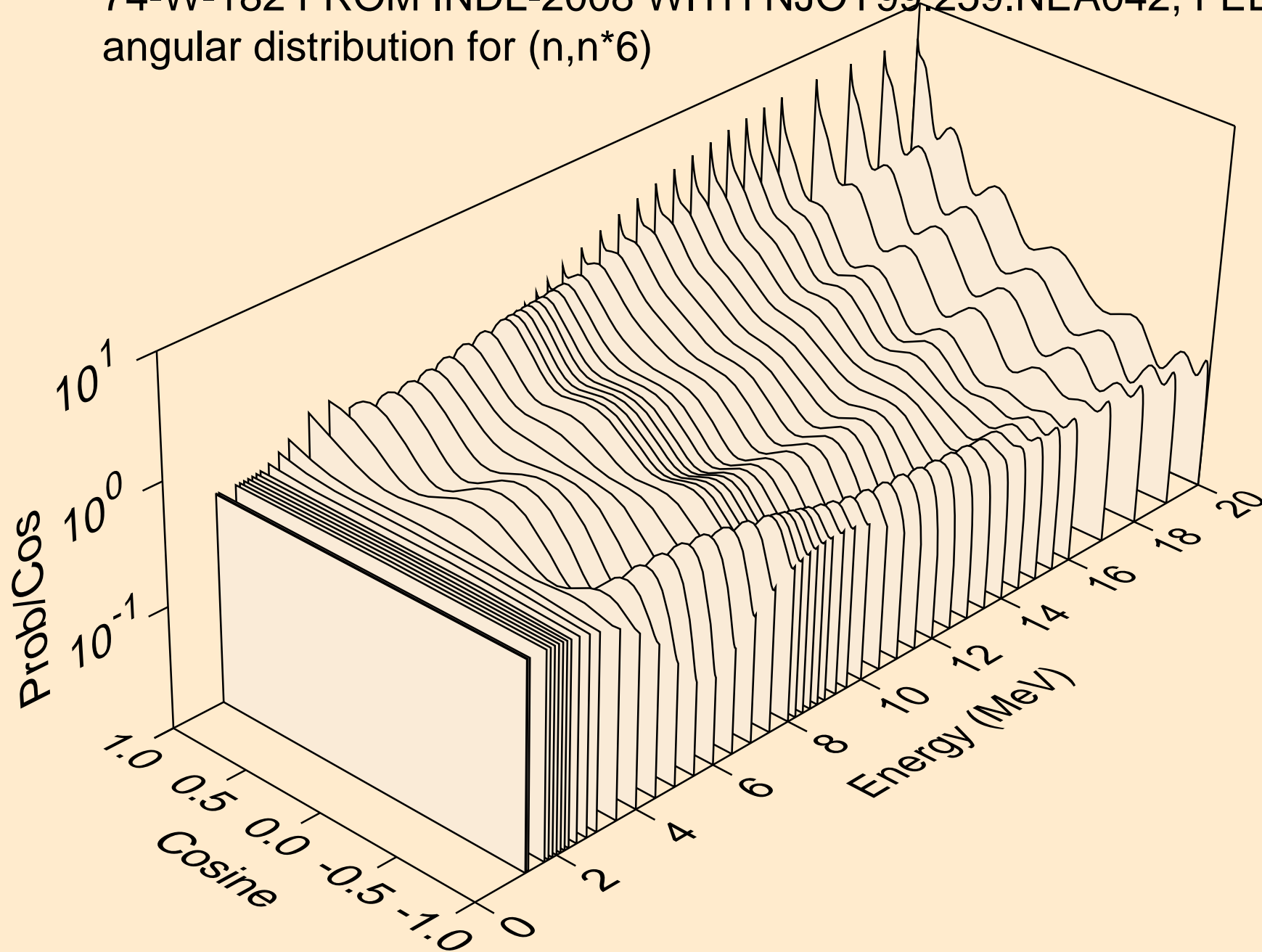

74-W-182 FROM INDL-2008 WITH NJOY99.259.NEA042, FEB. 200
angular distribution for (n,n*6)

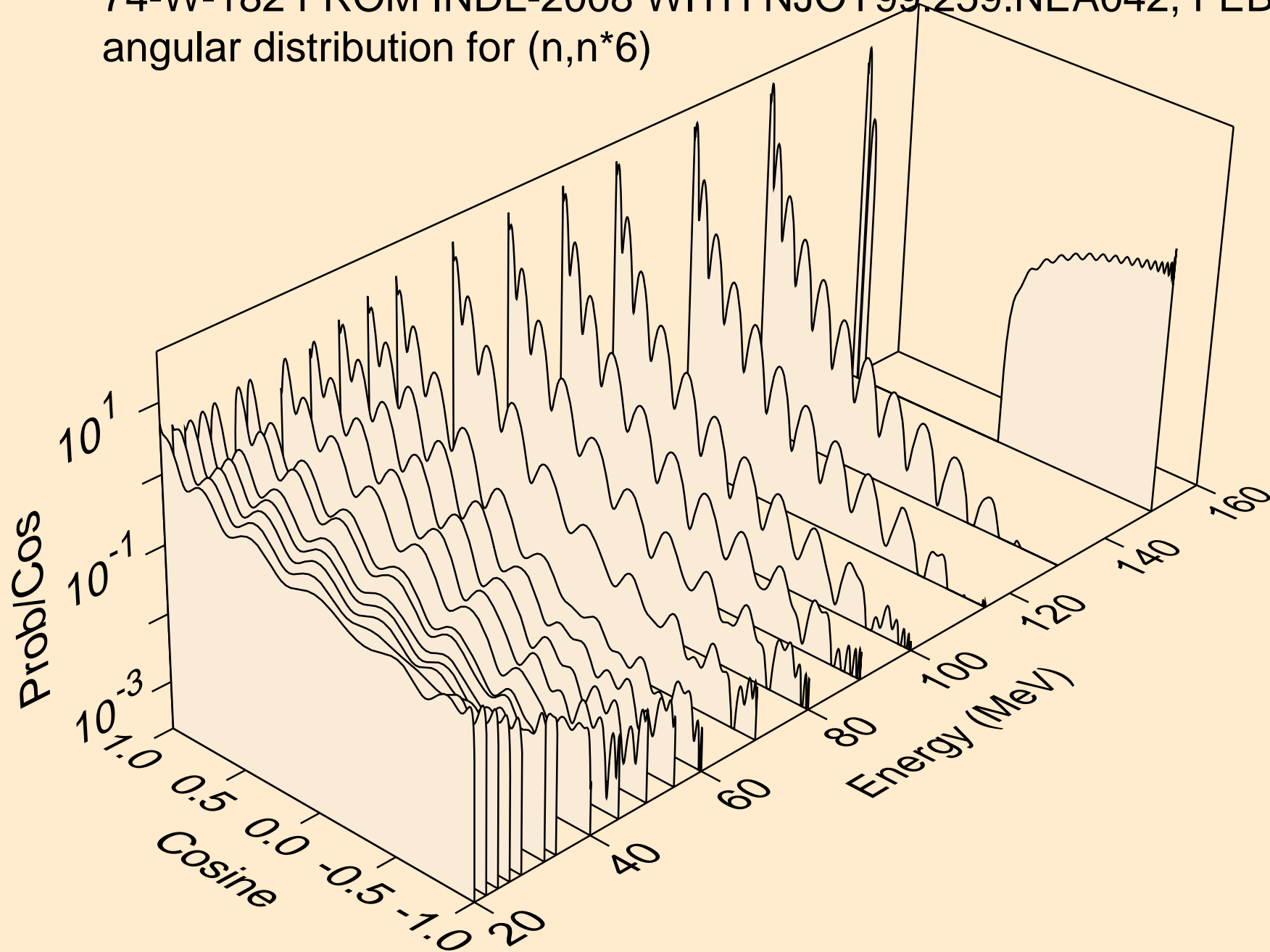

74-W-182 FROM INDL-2008 WITH NJOY99.259.NEA042, FEB. 200
angular distribution for (n,n*7)

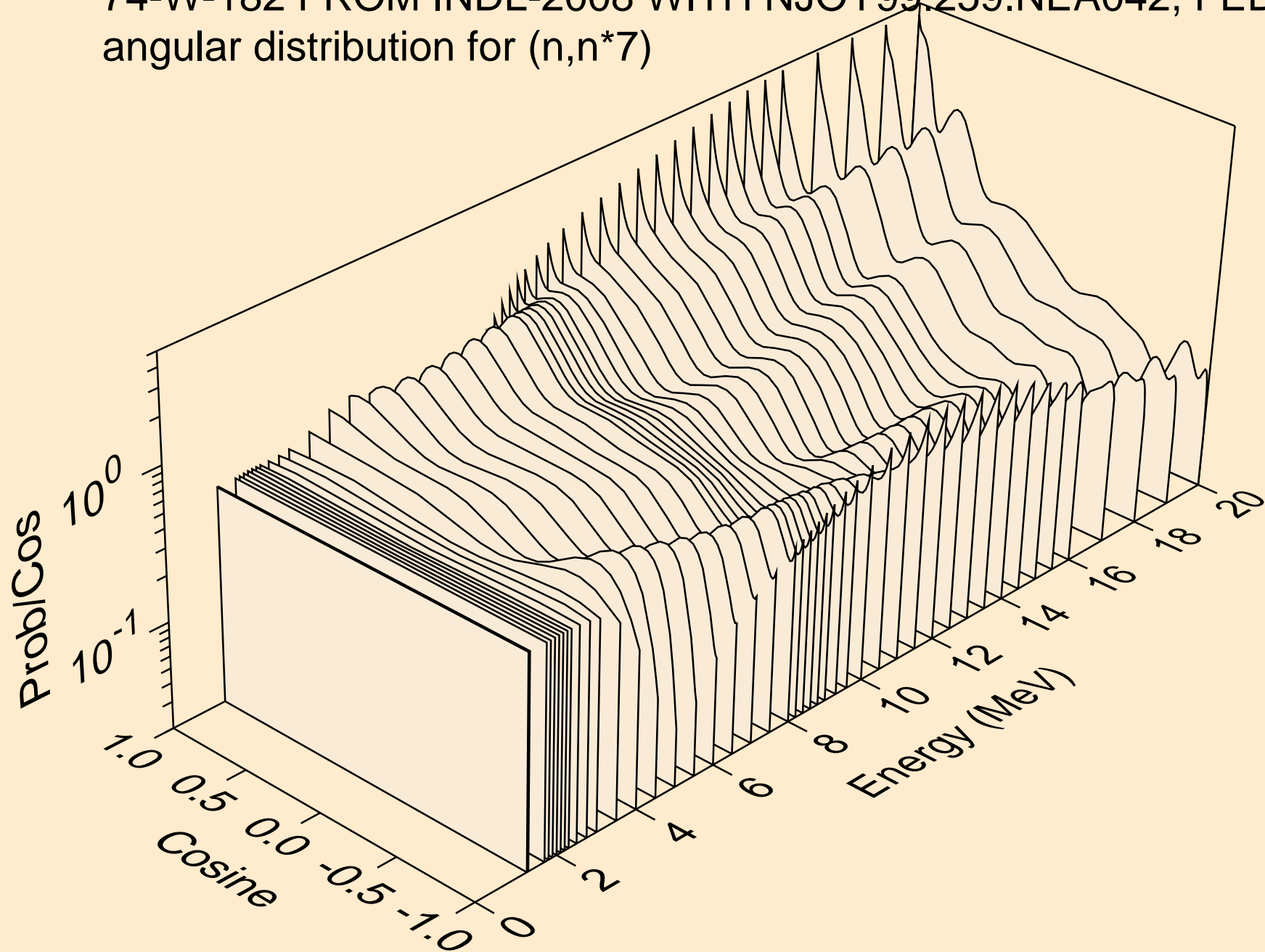

74-W-182 FROM INDL-2008 WITH NJOY99.259.NEA042, FEB. 200
angular distribution for (n,n*7)

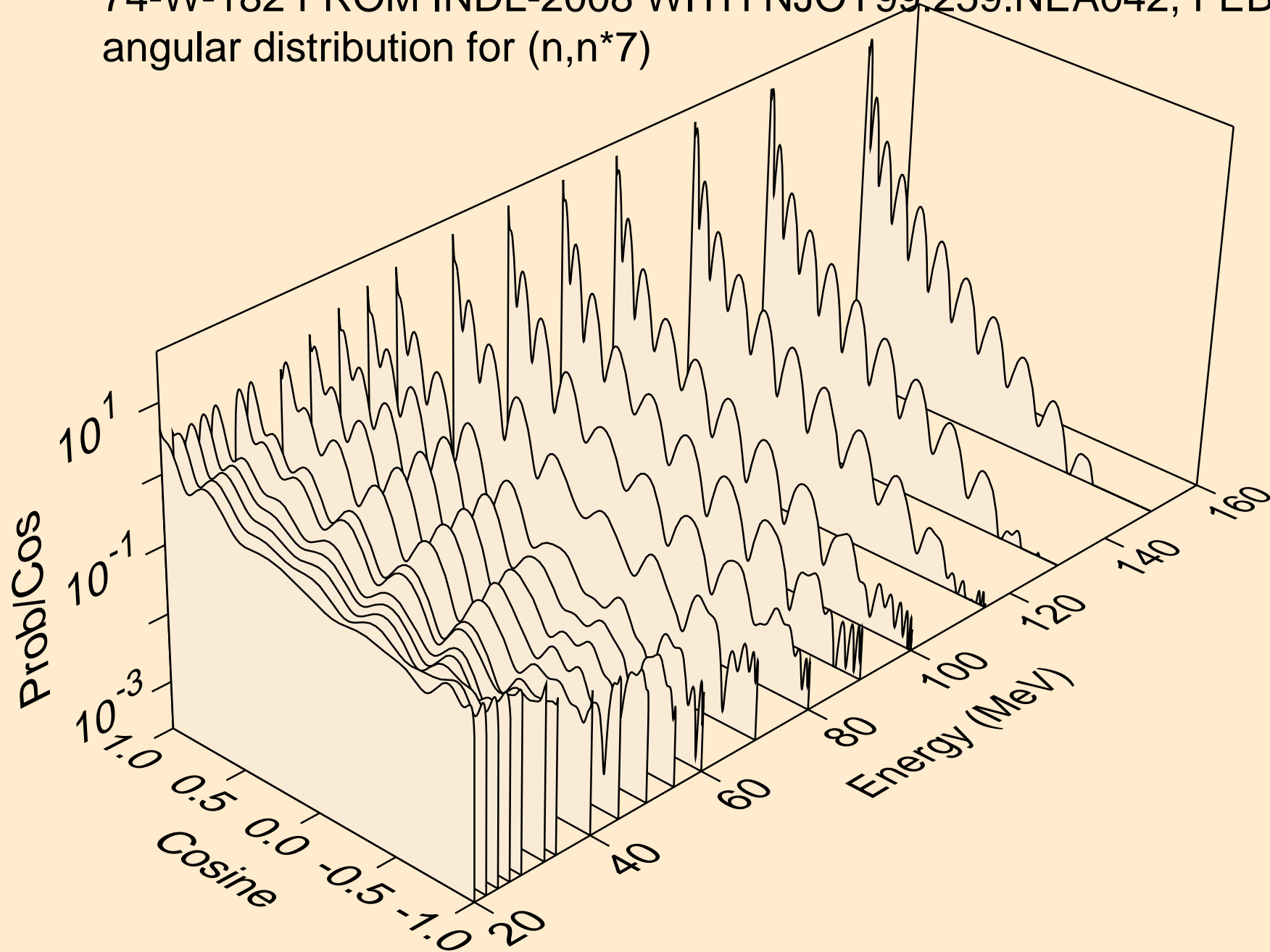

74-W-182 FROM INDL-2008 WITH NJOY99.259.NEA042, FEB. 200
angular distribution for (n,n*8)

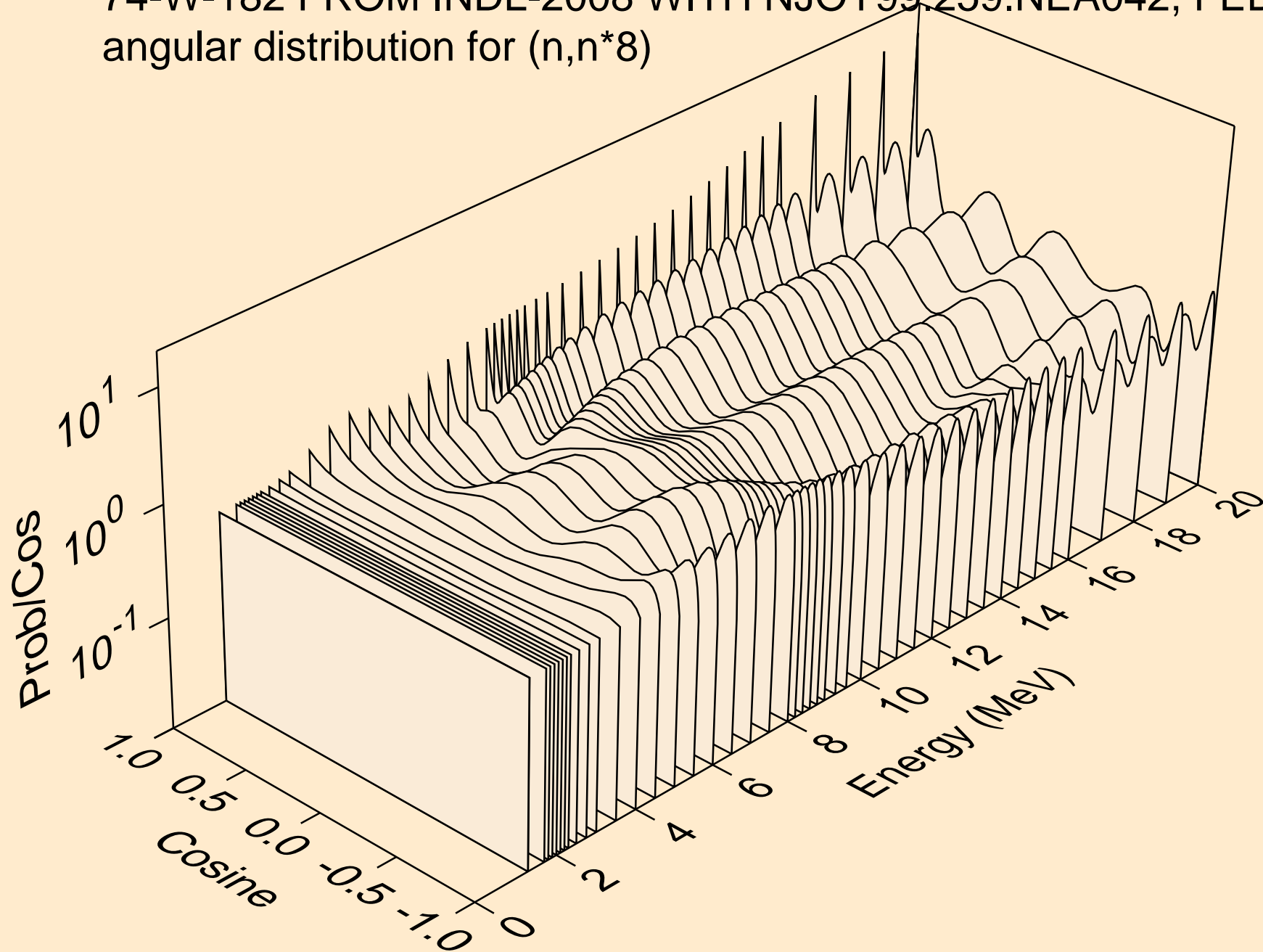

74-W-182 FROM INDL-2008 WITH NJOY99.259.NEA042, FEB. 200
angular distribution for (n,n*8)

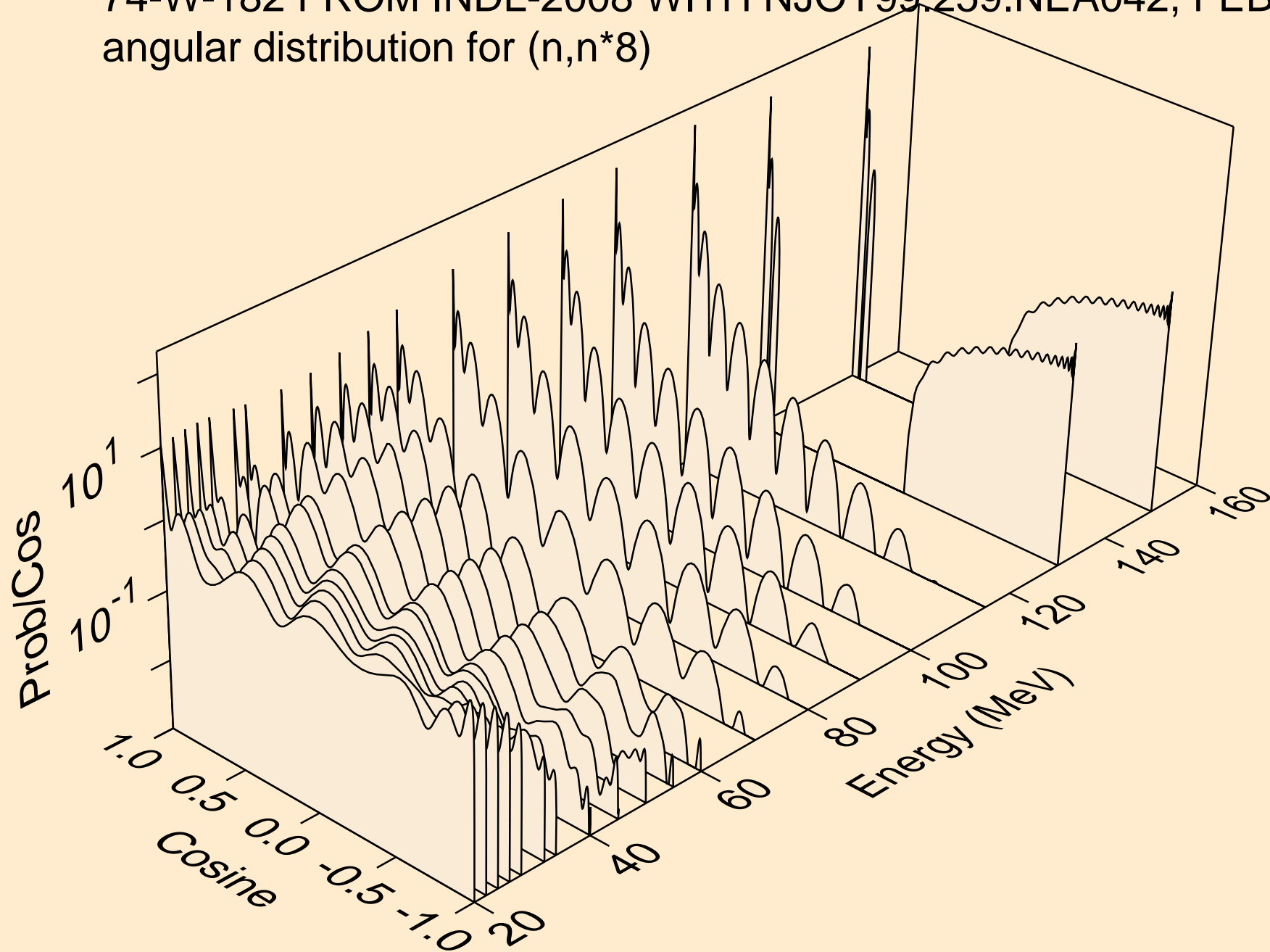

74-W-182 FROM INDL-2008 WITH NJOY99.259.NEA042, FEB. 200
angular distribution for (n,n*9)

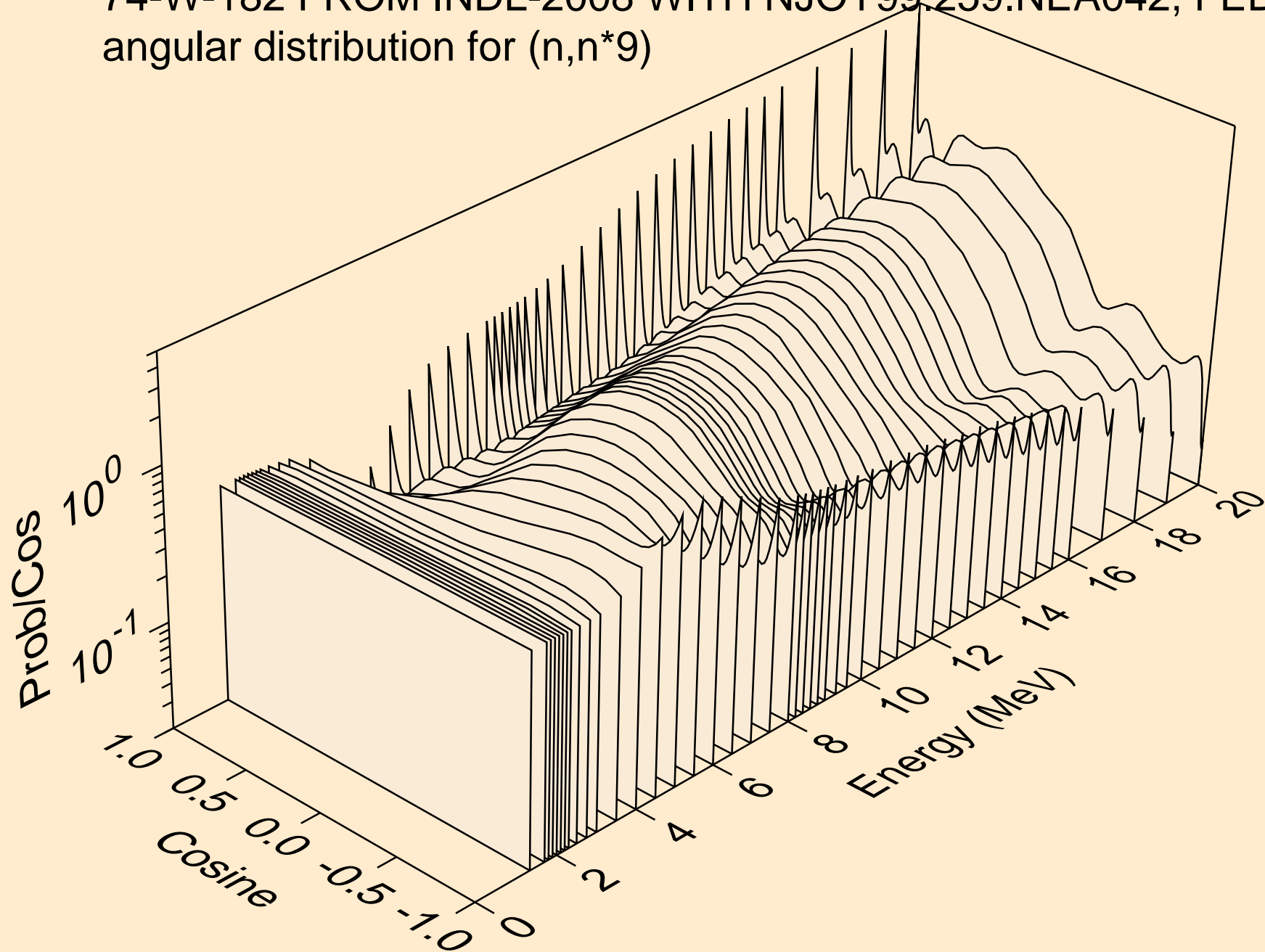

74-W-182 FROM INDL-2008 WITH NJOY99.259.NEA042, FEB. 200
angular distribution for (n,n*9)

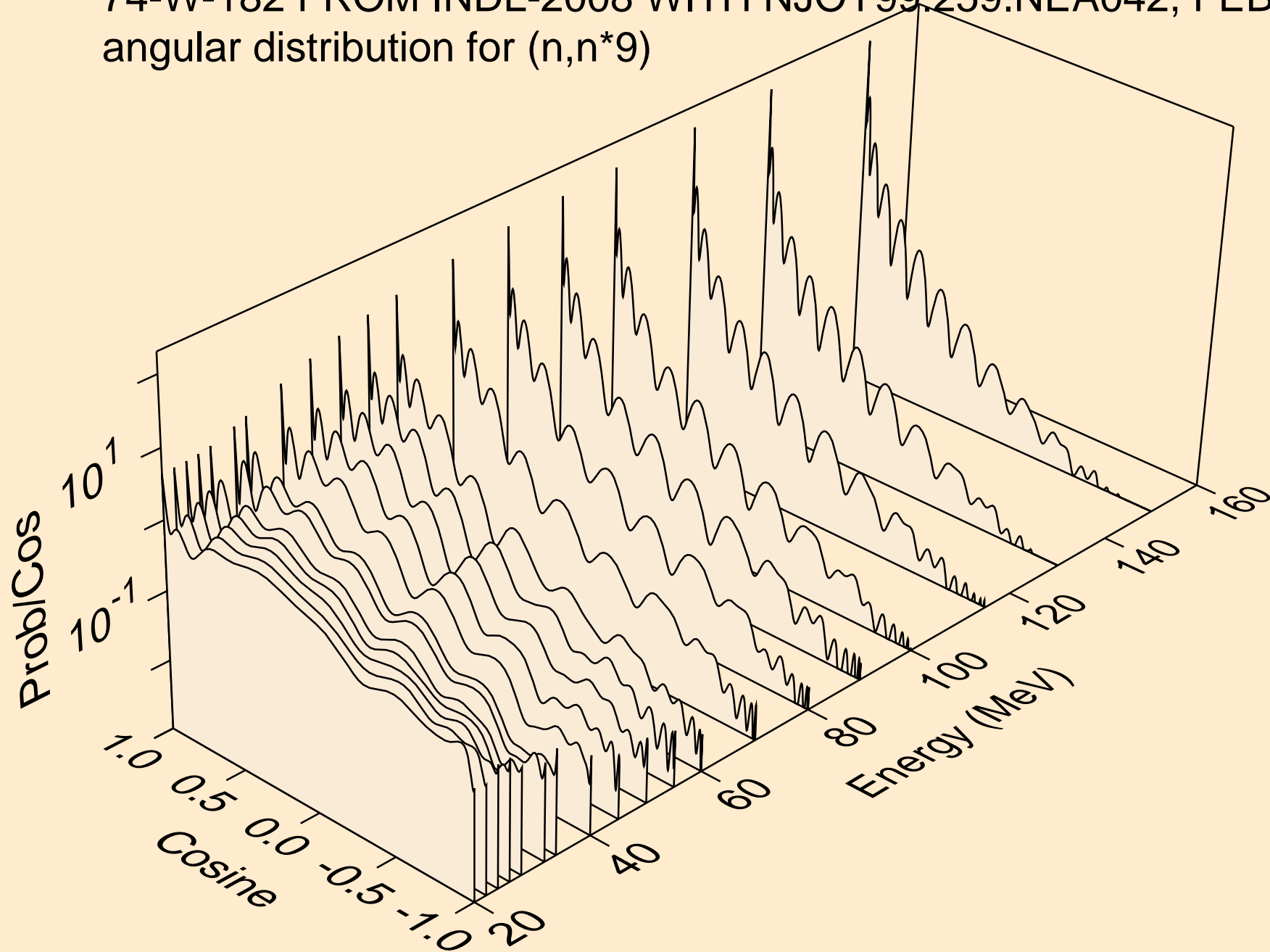

74-W-182 FROM INDL-2008 WITH NJOY99.259.NEA042, FEB. 200
Neutron emission for (n,x)

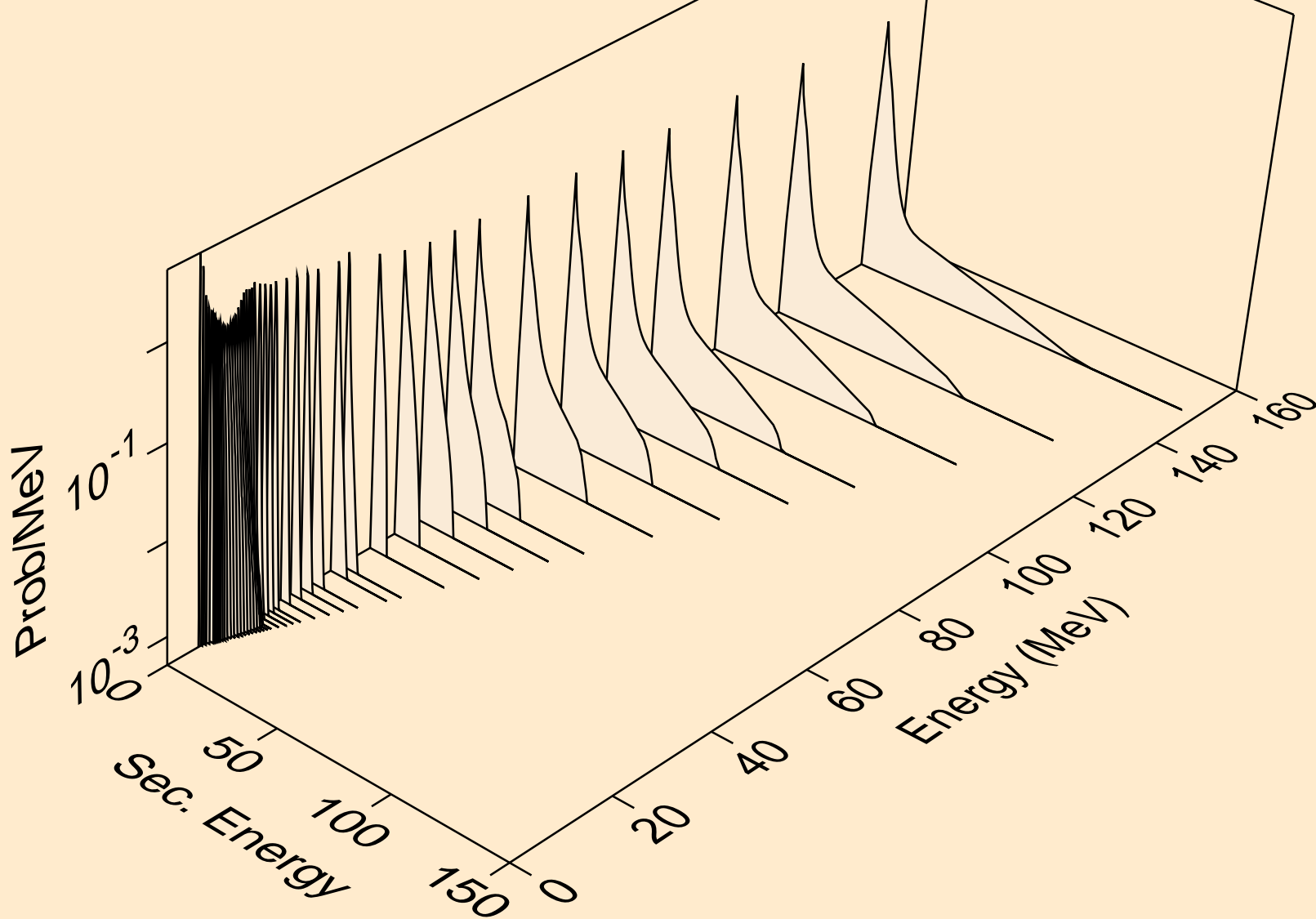

74-W-182 FROM INDL-2008 WITH NJOY99.259.NEA042, FEB. 200
Neutron emission for (n,2n)

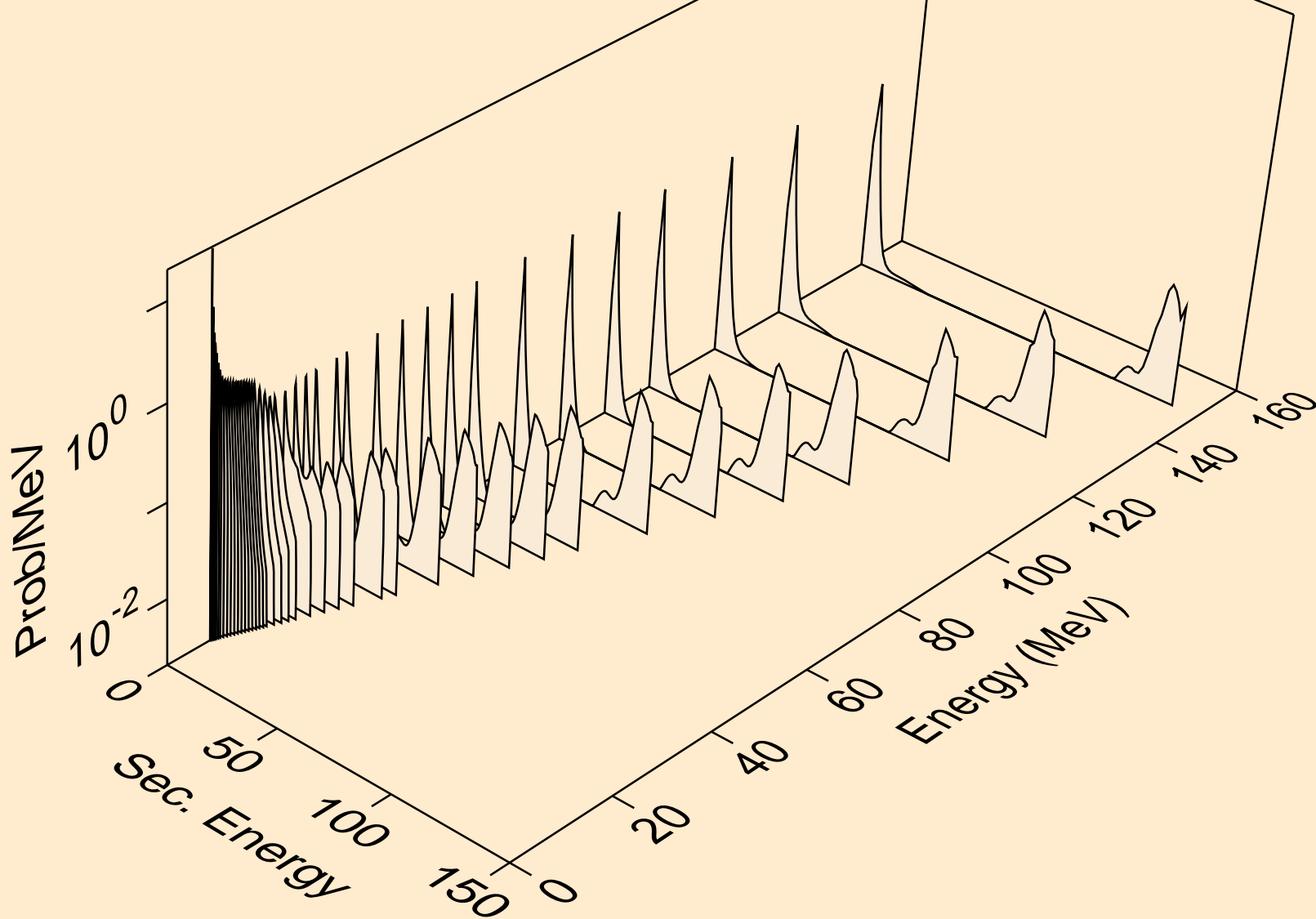

74-W-182 FROM INDL-2008 WITH NJOY99.259.NEA042, FEB. 200
Neutron emission for (n,3n)

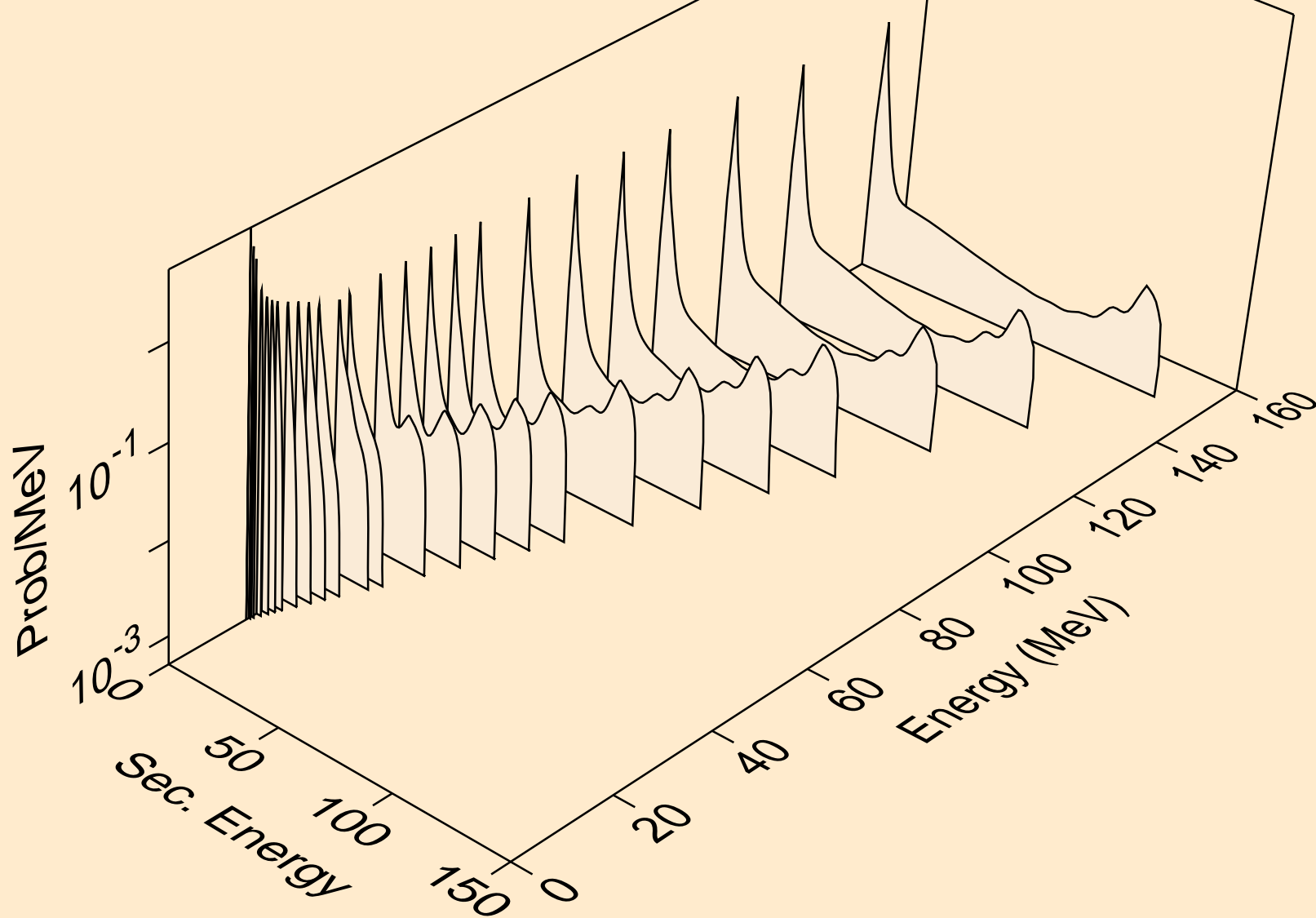

74-W-182 FROM INDL-2008 WITH NJOY99.259.NEA042, FEB. 200
Neutron emission for (n,n*)p

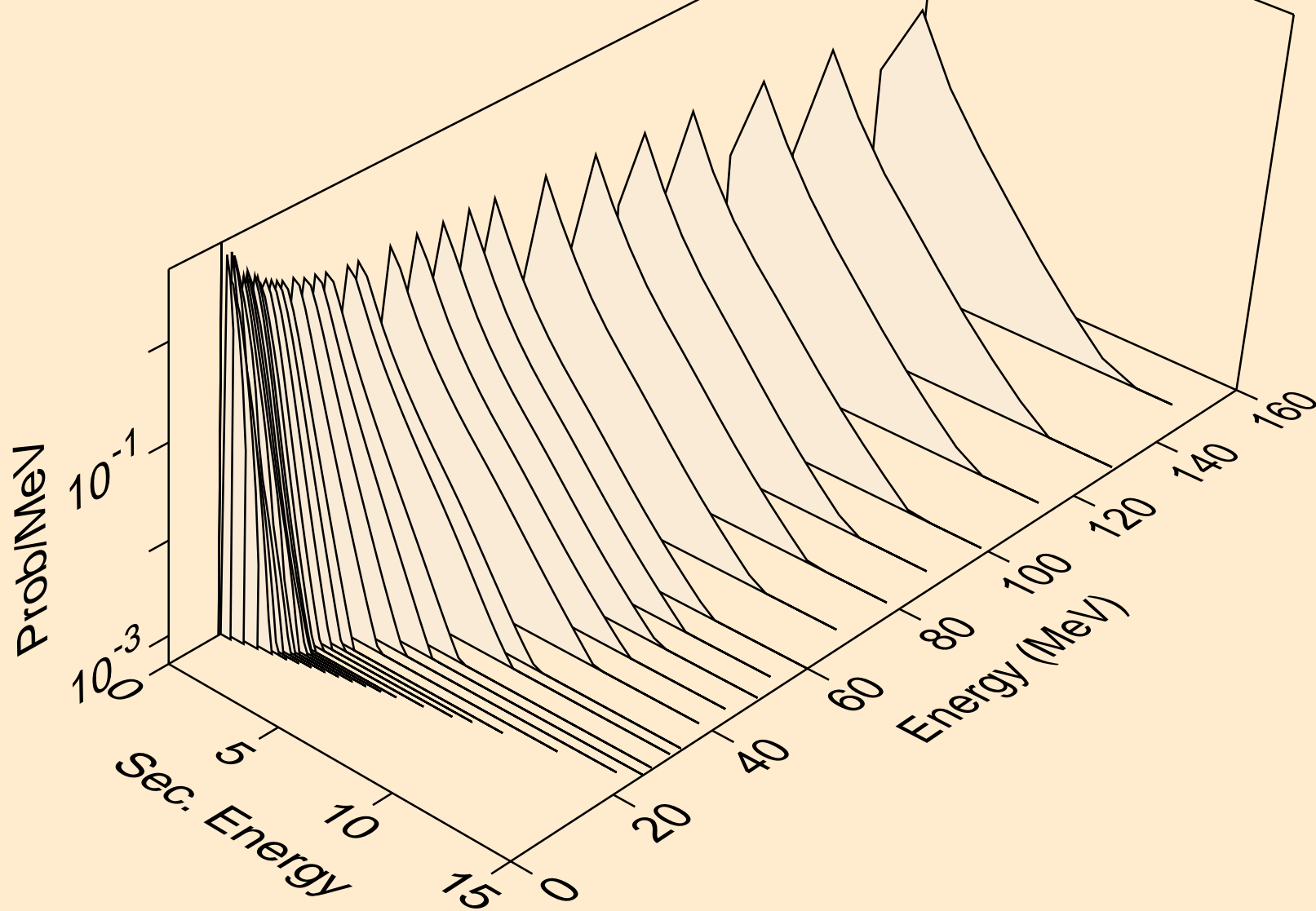

74-W-182 FROM INDL-2008 WITH NJOY99.259.NEA042, FEB. 200
Neutron emission for (n,4n)

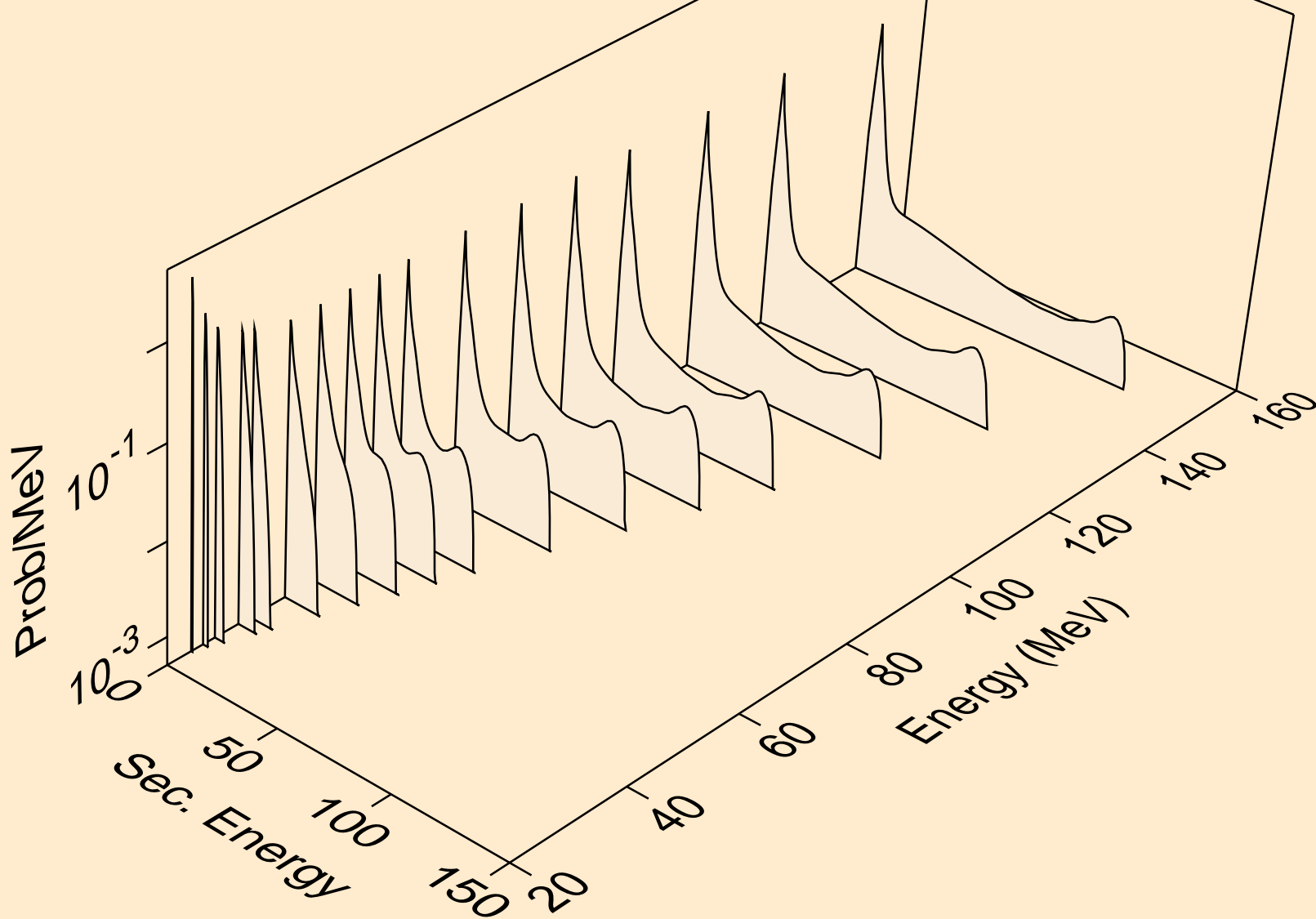

74-W-182 FROM INDL-2008 WITH NJOY99.259.NEA042, FEB. 200
Neutron emission for (n,2np)

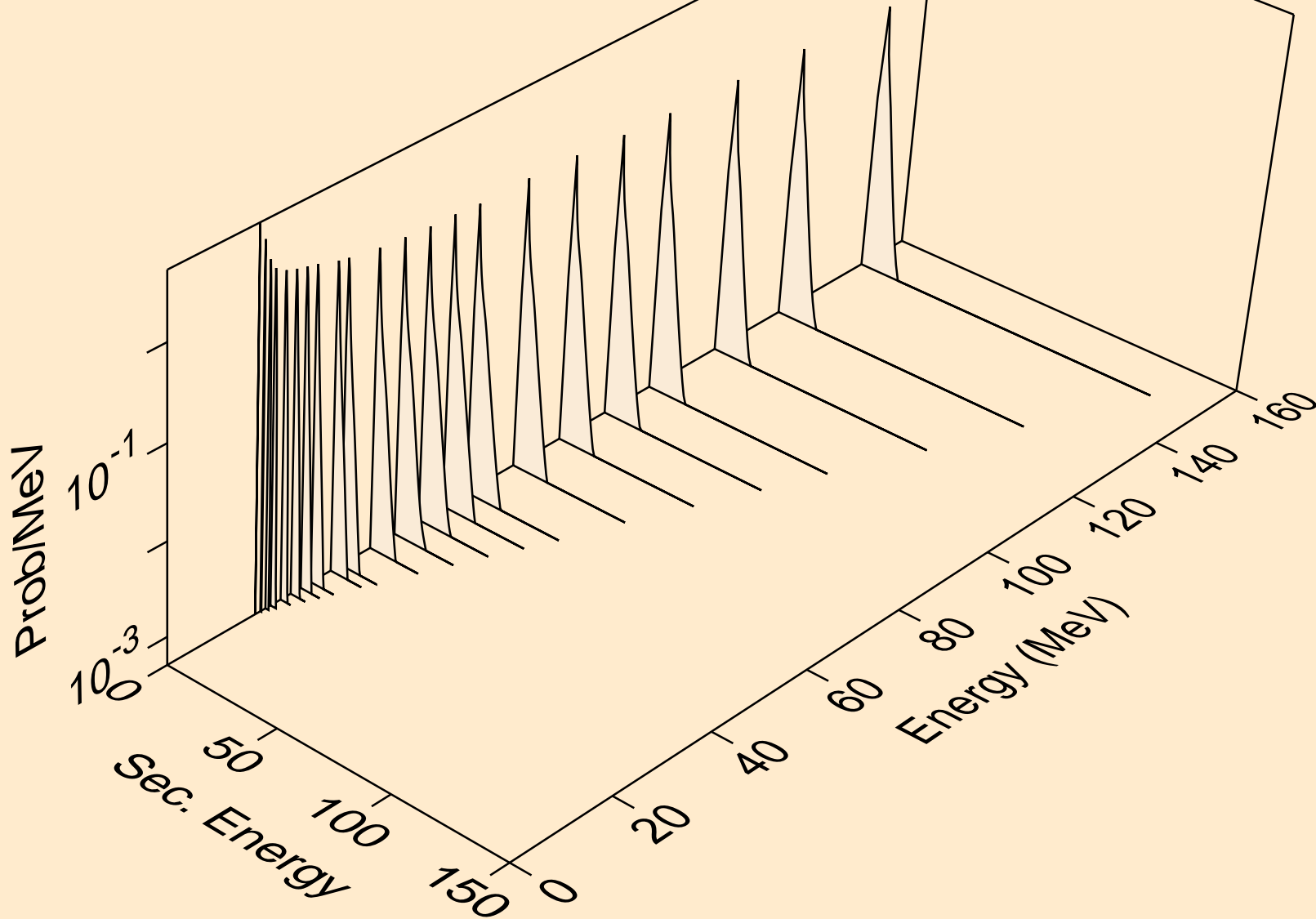

74-W-182 FROM INDL-2008 WITH NJOY99.259.NEA042, FEB. 200
Neutron emission for (n,n*c)

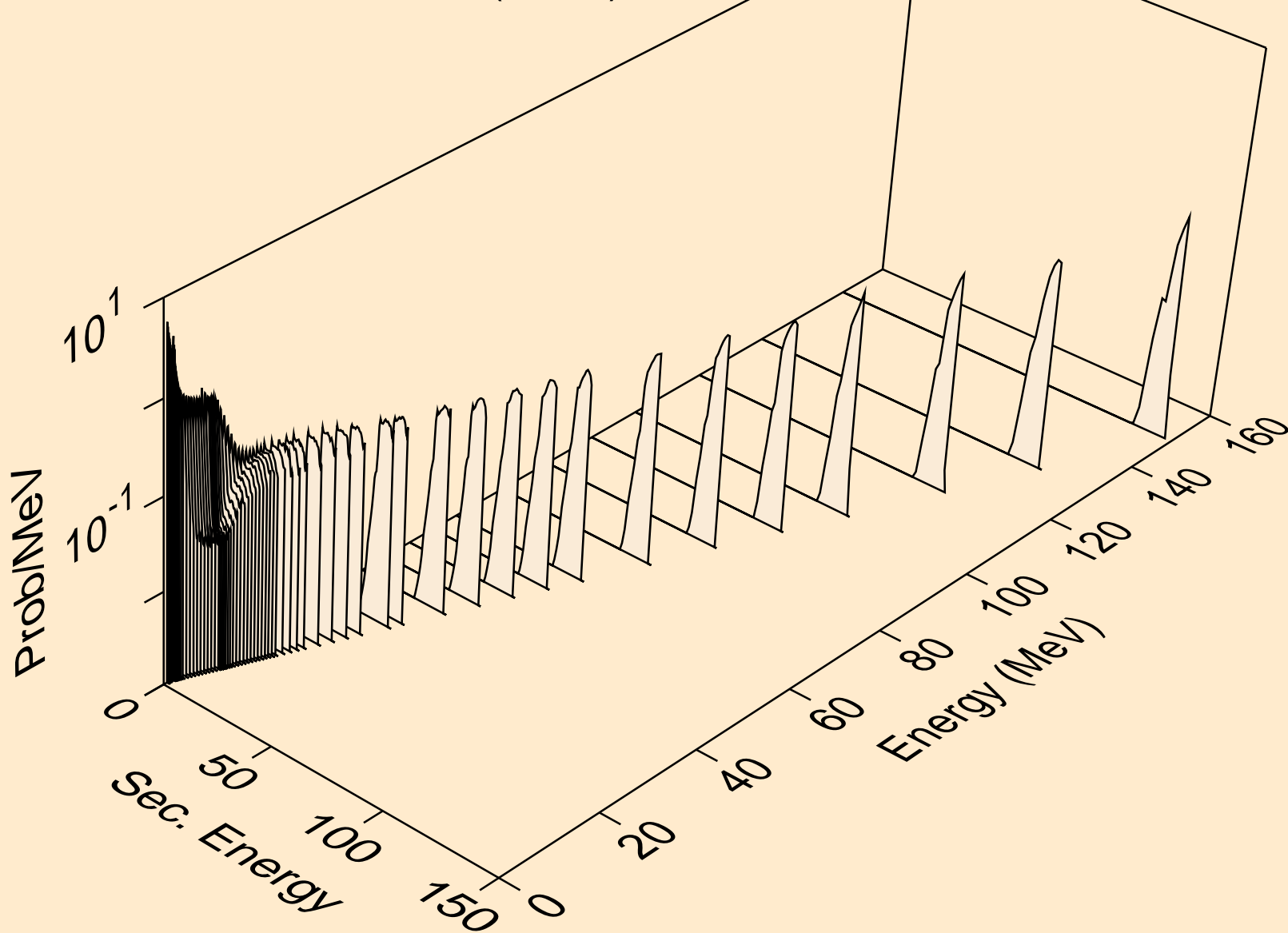

74-W-182 FROM INDL-2008 WITH NJOY99.259.NEA042, FEB. 200
Photon emission for (n,x)

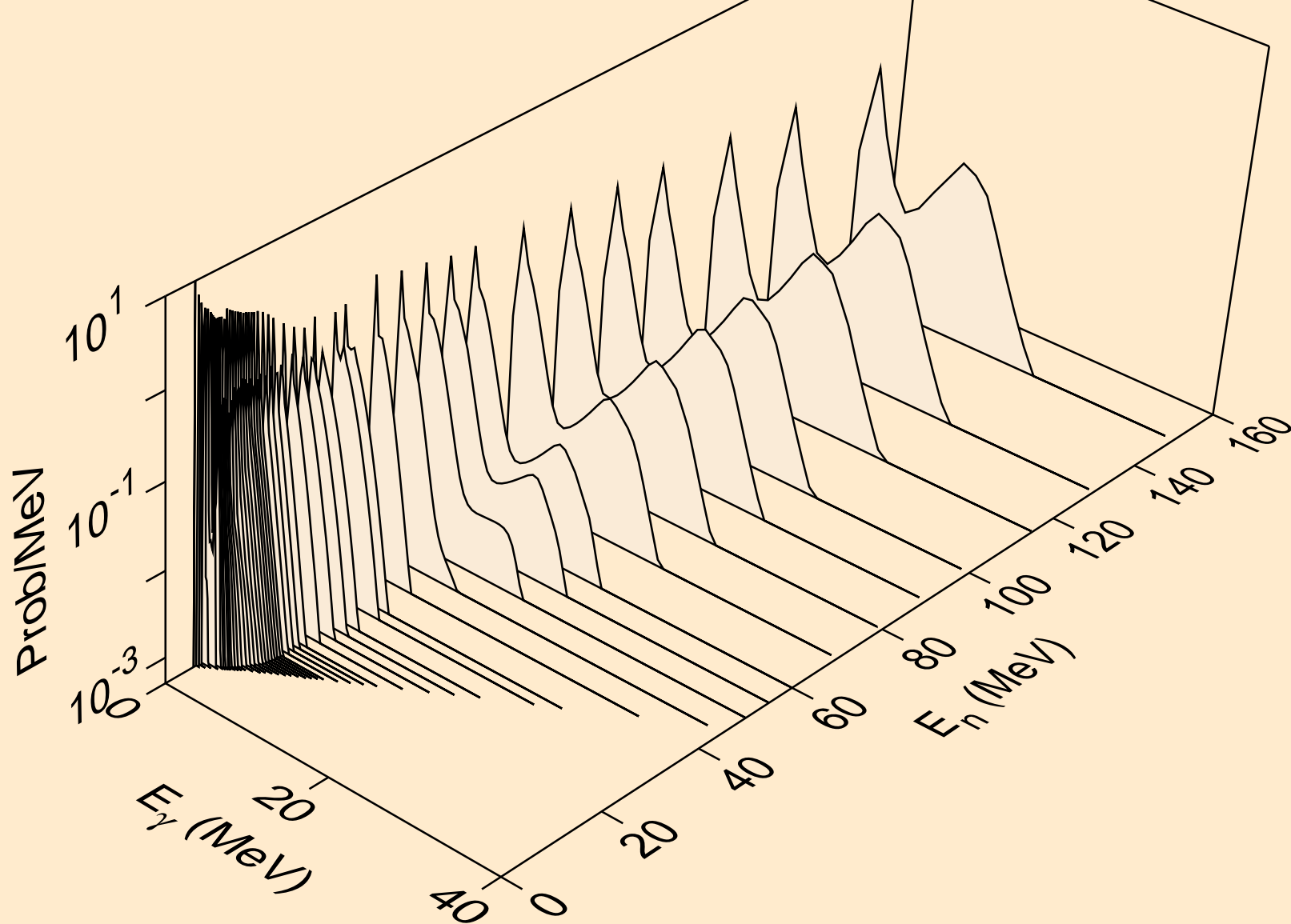

74-W-182 FROM INDL-2008 WITH NJOY99.259.NEA042, FEB. 200
Photon emission for (n,2n)

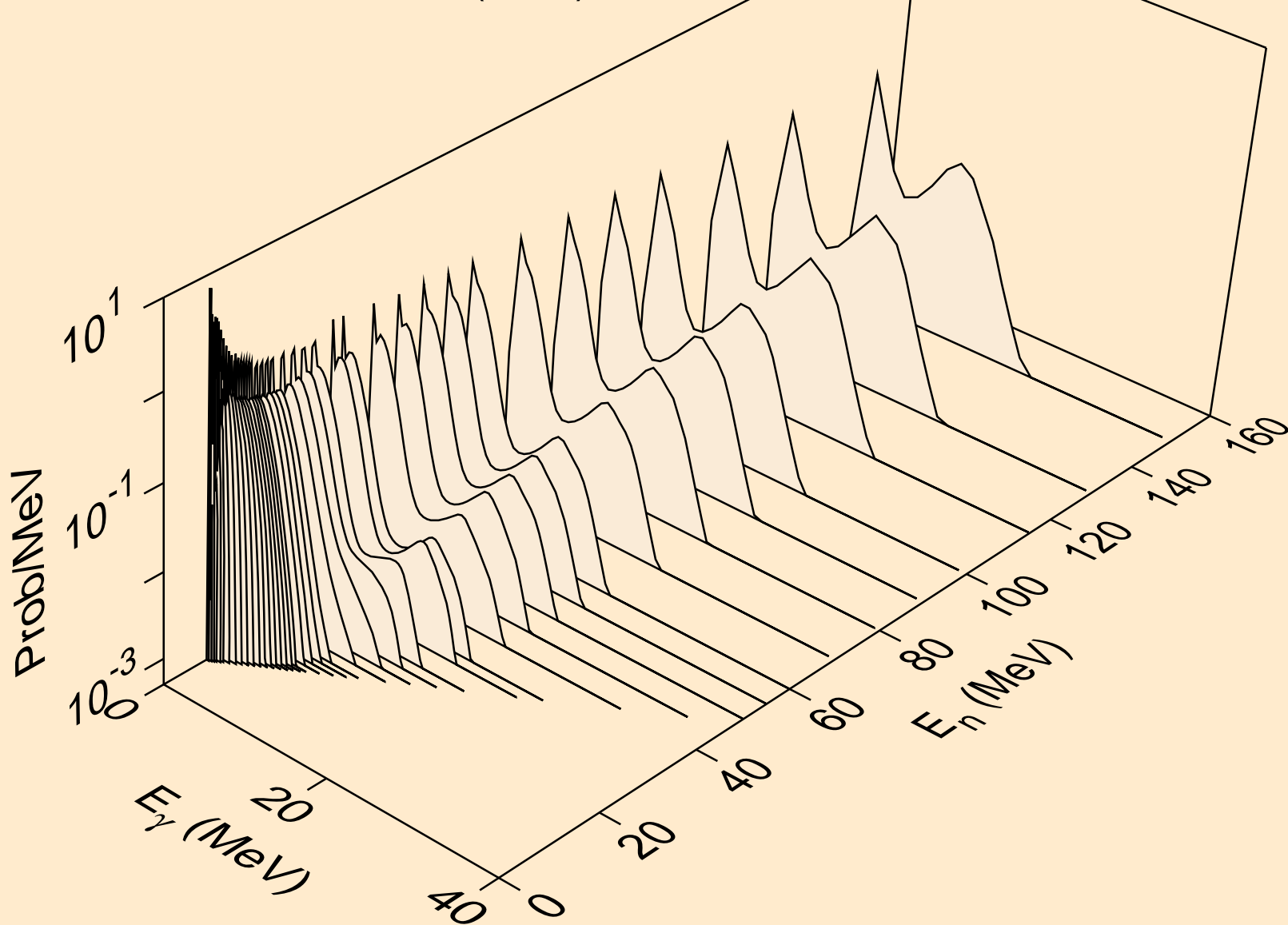

74-W-182 FROM INDL-2008 WITH NJOY99.259.NEA042, FEB. 200
Photon emission for (n,3n)

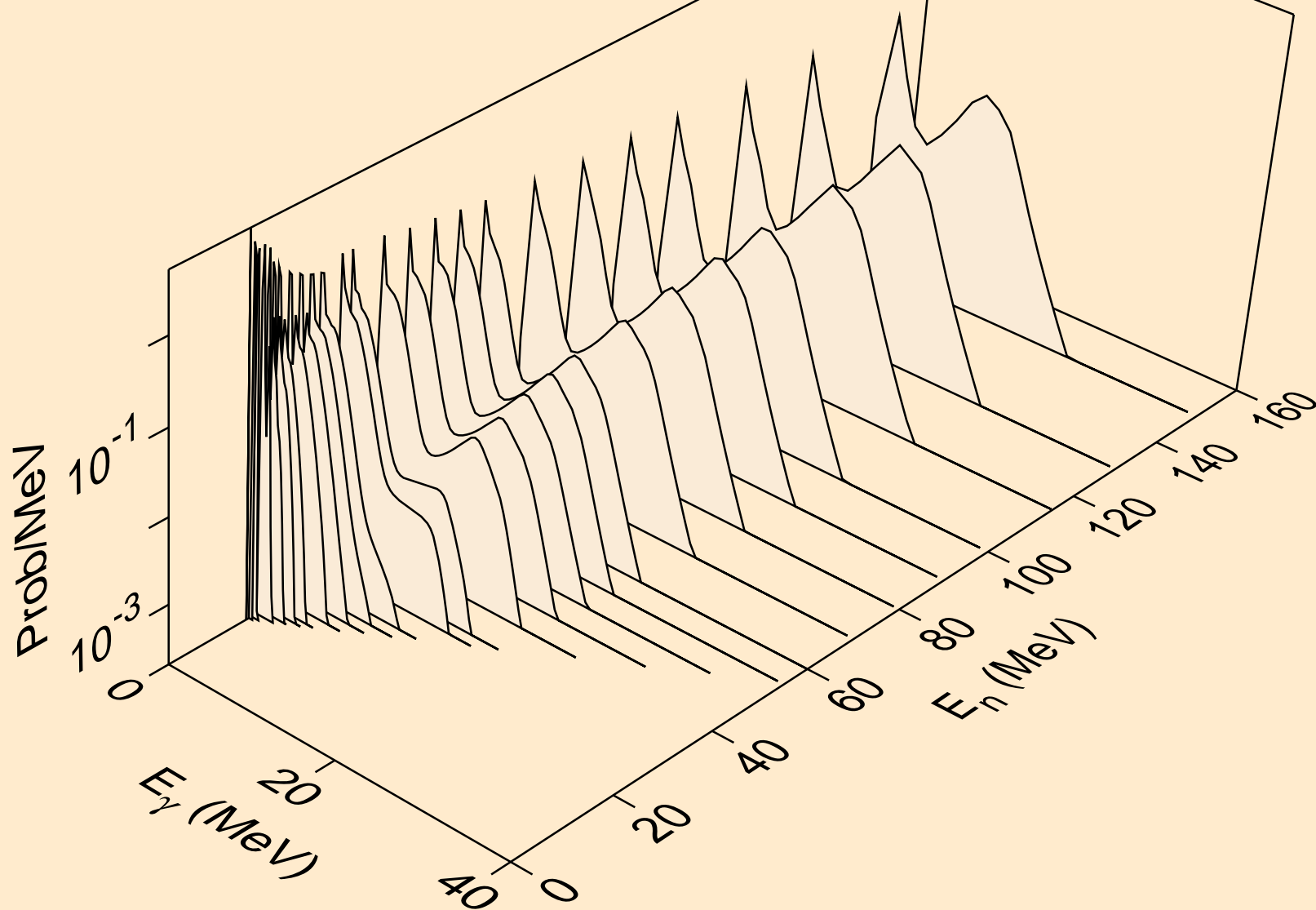

74-W-182 FROM INDL-2008 WITH NJOY99.259.NEA042, FEB. 200
Photon emission for (n,n*)p

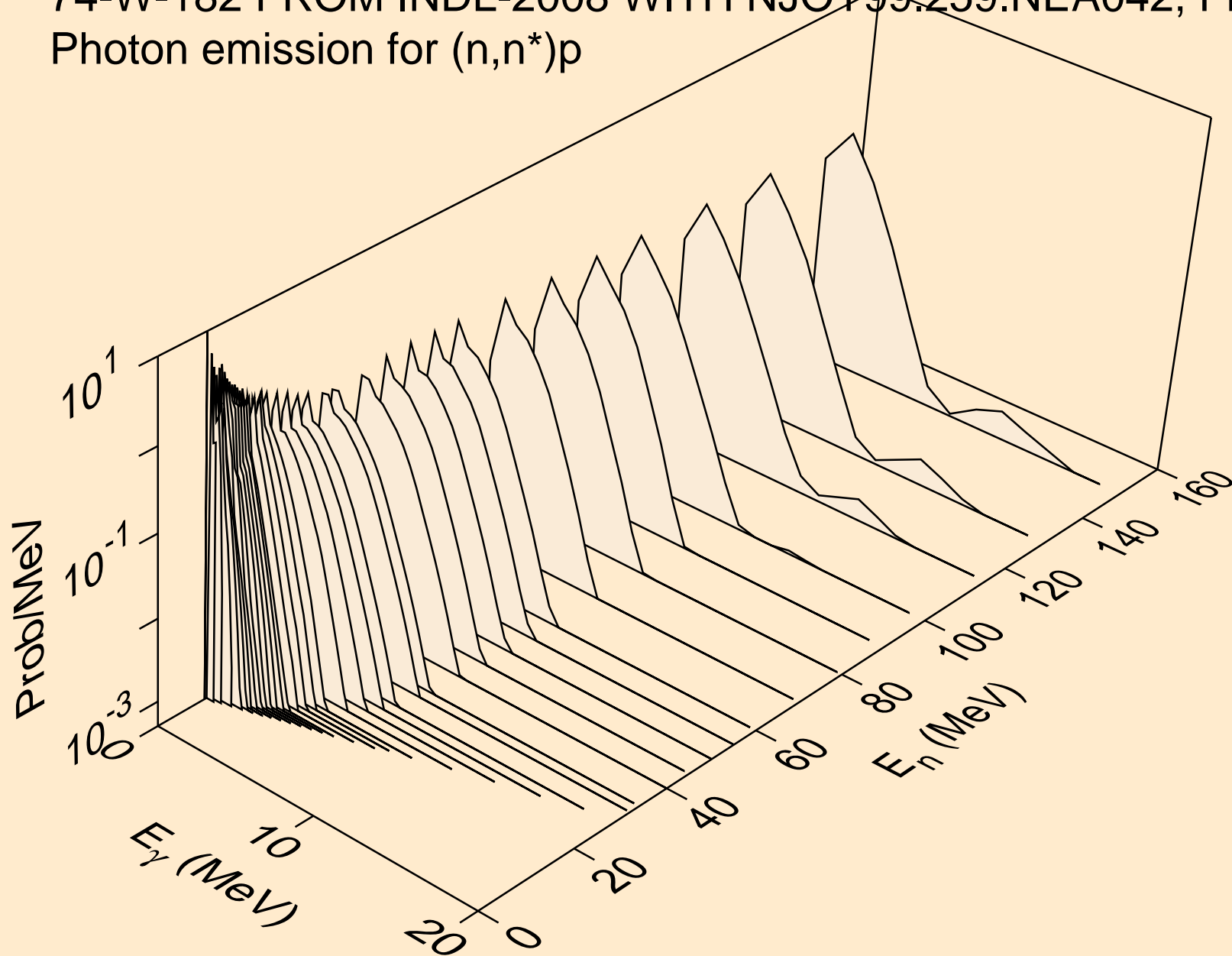

74-W-182 FROM INDL-2008 WITH NJOY99.259.NEA042, FEB. 200
Photon emission for (n,4n)

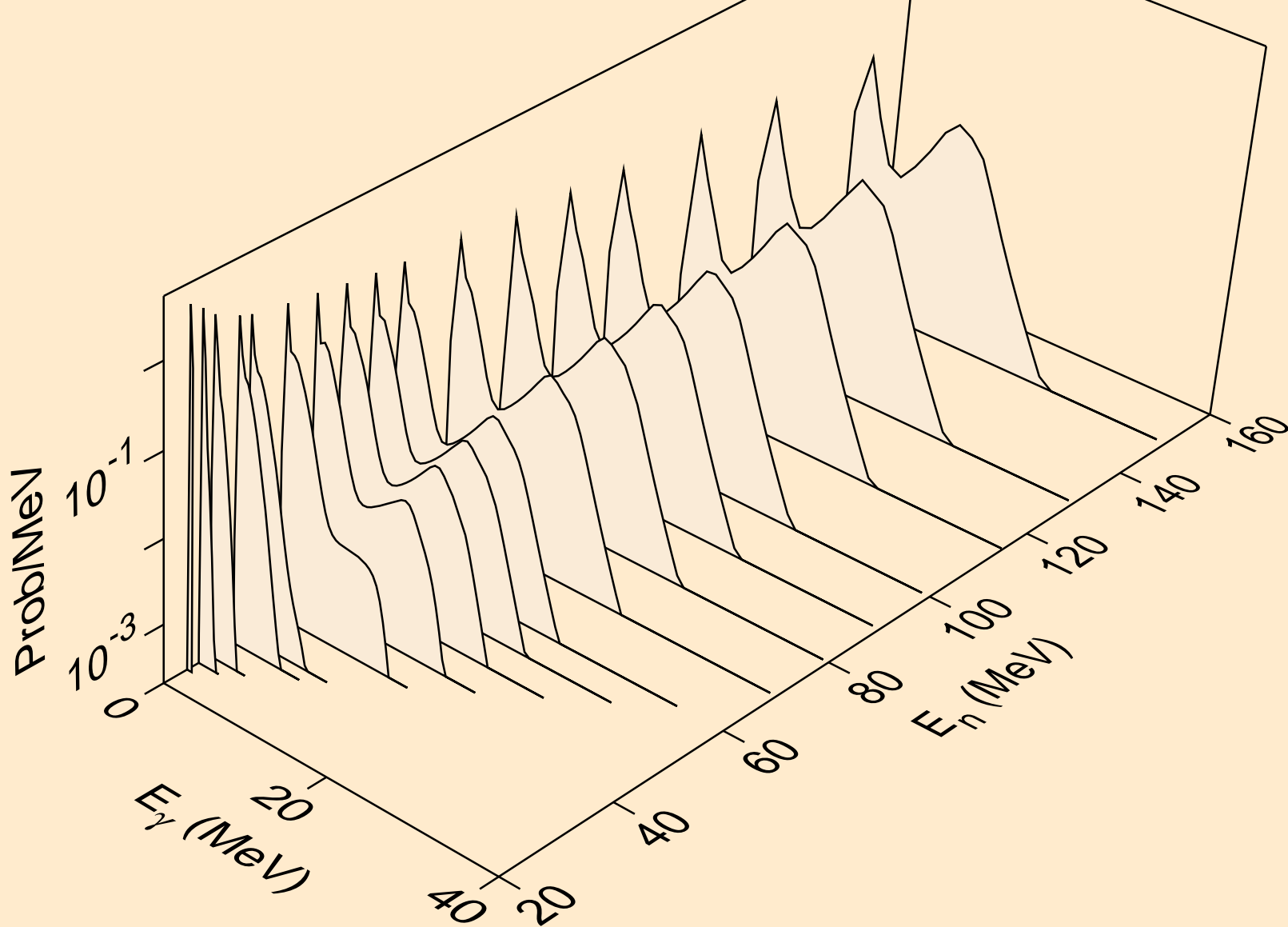

74-W-182 FROM INDL-2008 WITH NJOY99.259.NEA042, FEB. 200
Photon emission for (n,2np)

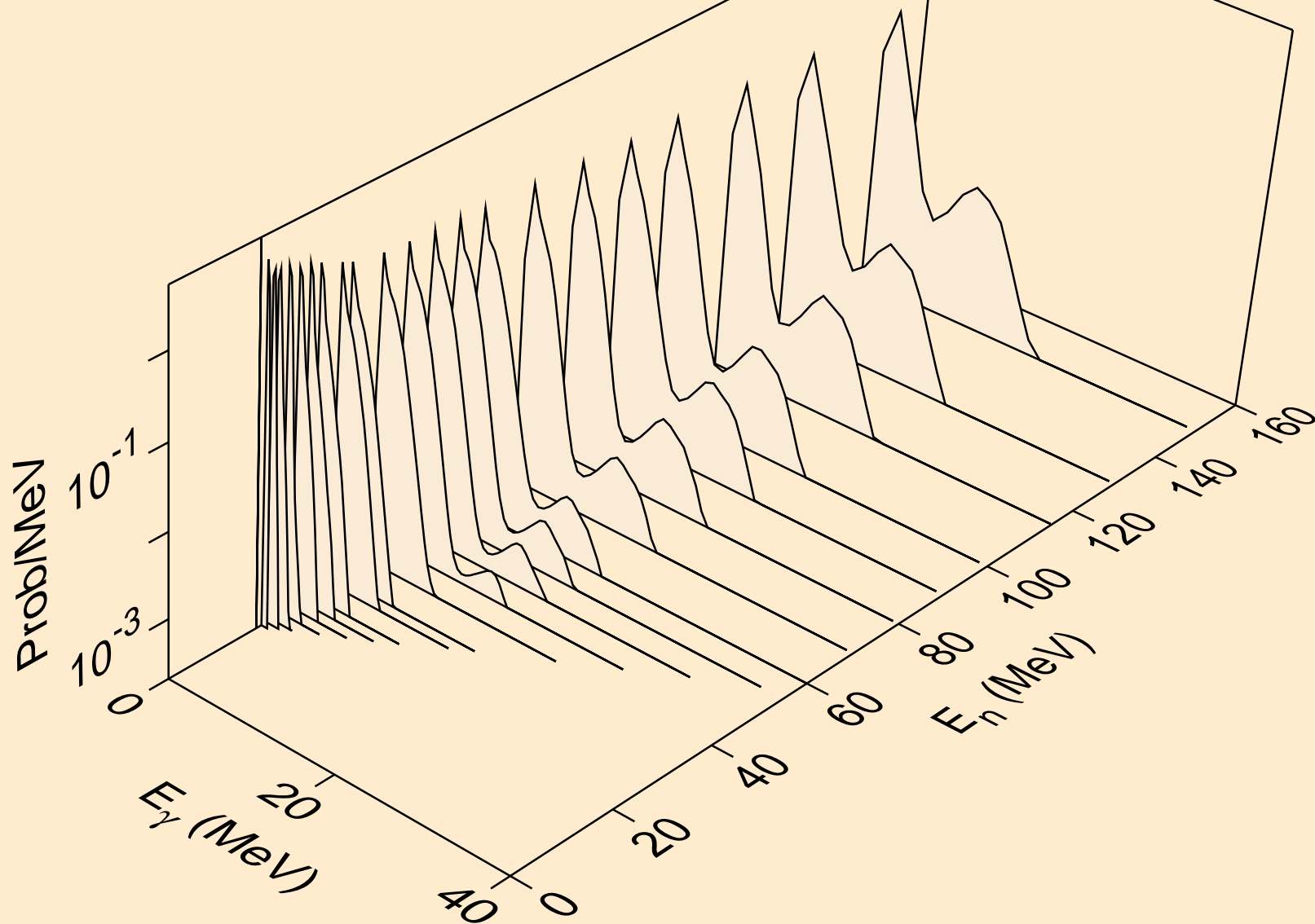

74-W-182 FROM INDL-2008 WITH NJOY99.259.NEA042, FEB. 200
Photon emission for (n,n*c)

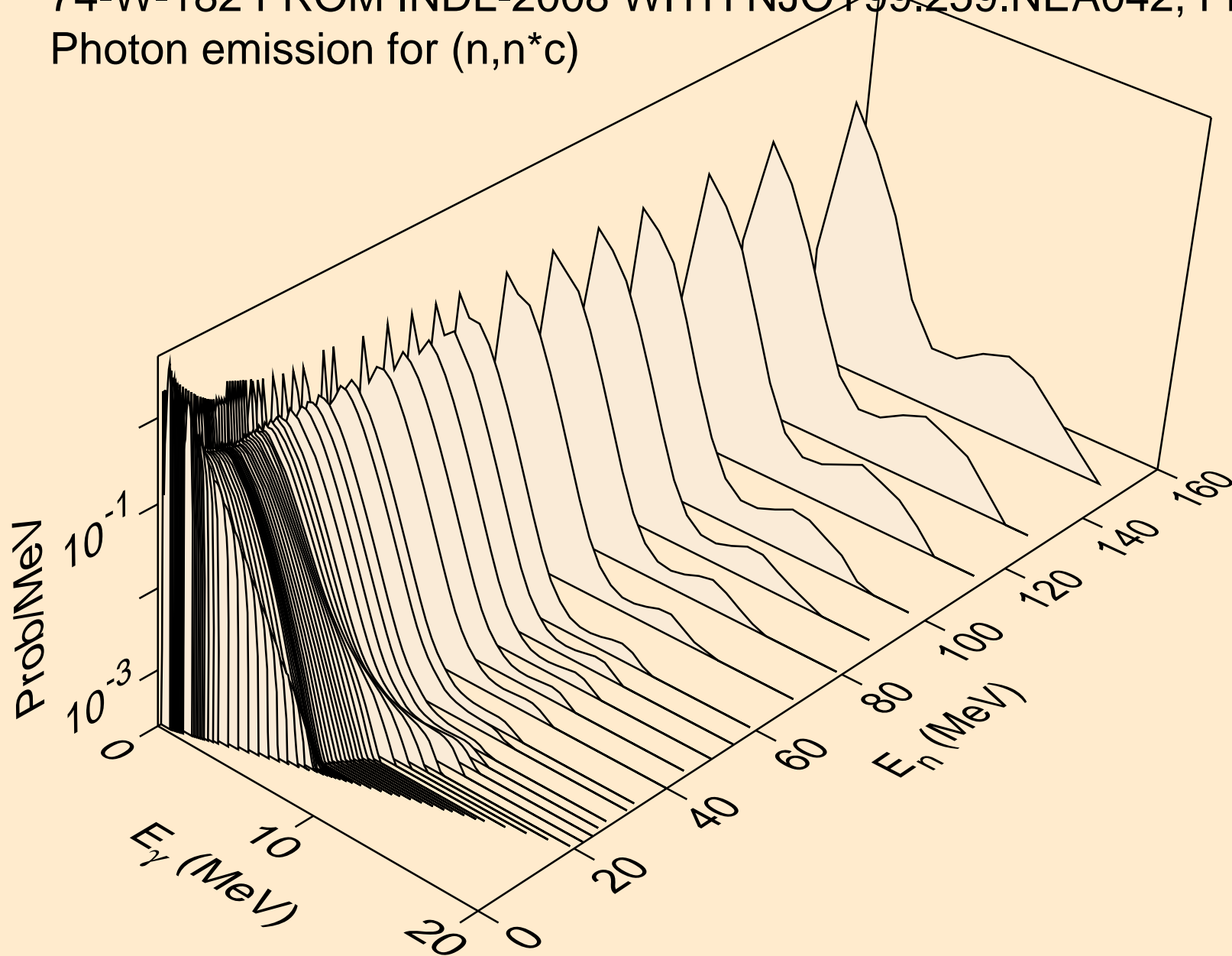

74-W-182 FROM INDL-2008 WITH NJOY99.259.NEA042, FEB. 200
Photon emission for (n,gma)

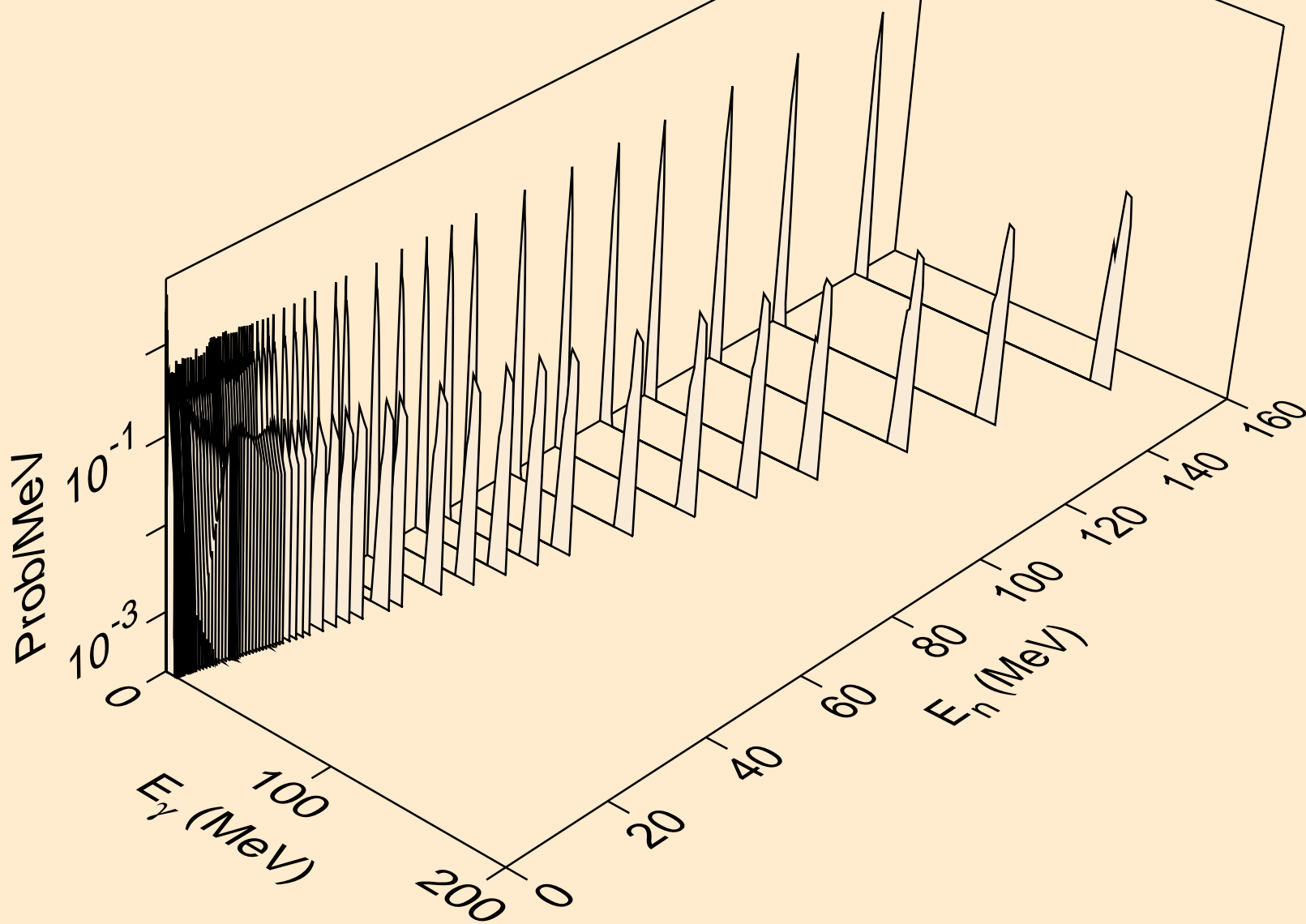

74-W-182 FROM INDL-2008 WITH NJOY99.259.NEA042, FEB. 200
Photon emission for (n,p*c)

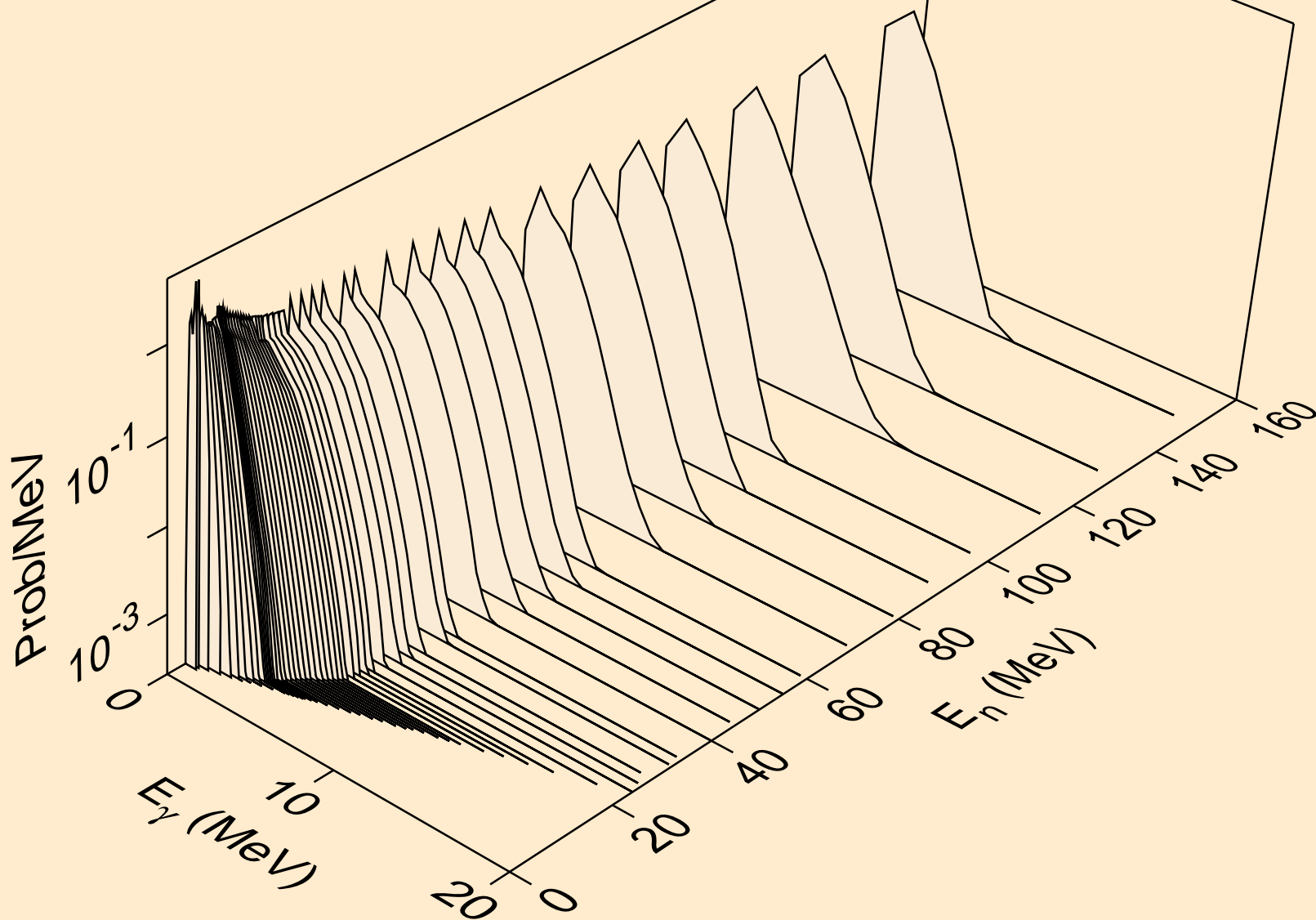

74-W-182 FROM INDL-2008 WITH NJOY99.259.NEA042, FEB. 200
Photon emission for (n,a*c)

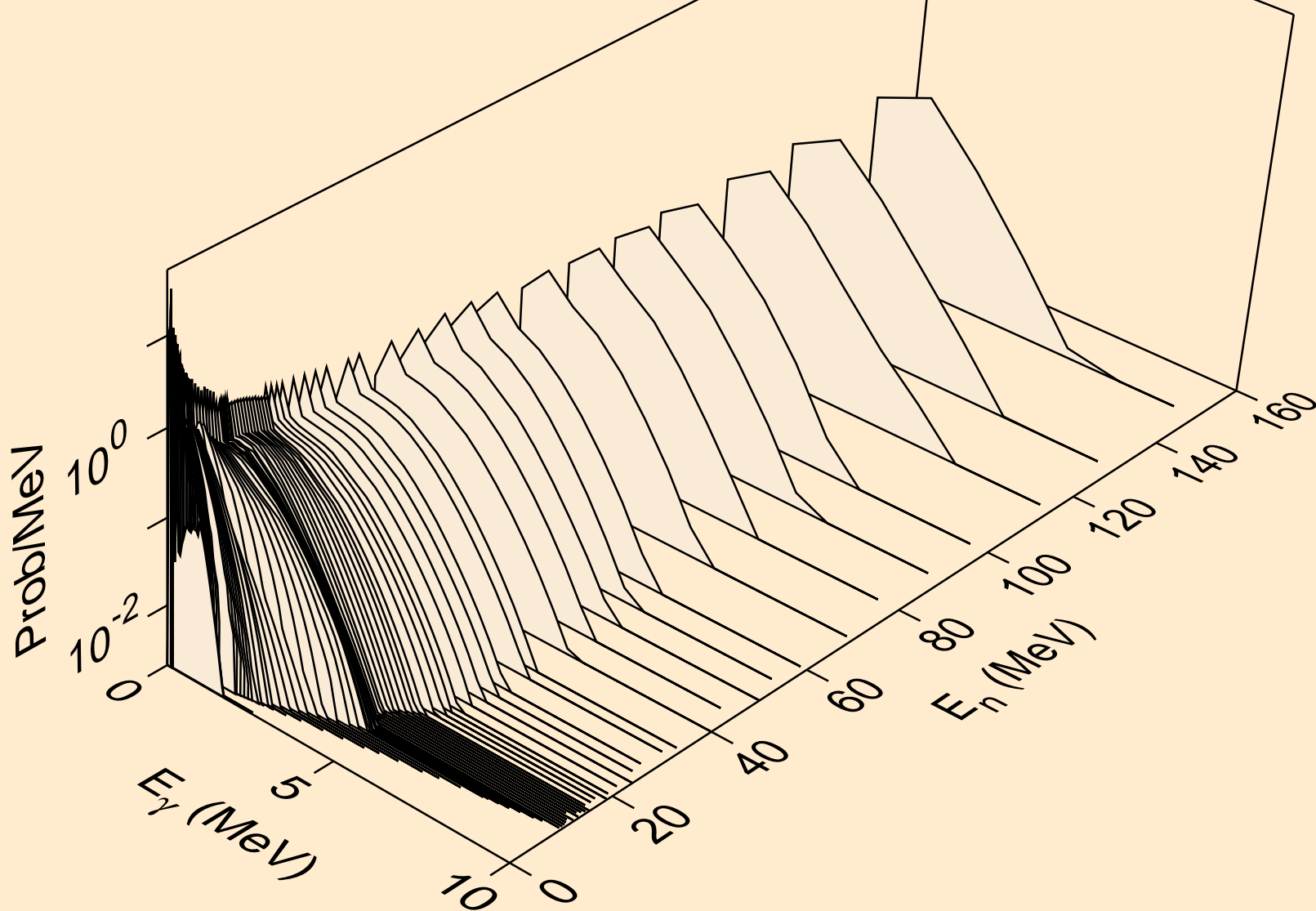

74-W-182 FROM INDL-2008 WITH NJOY99.259.NEA042, FEB. 200
thermal capture photon spectrum

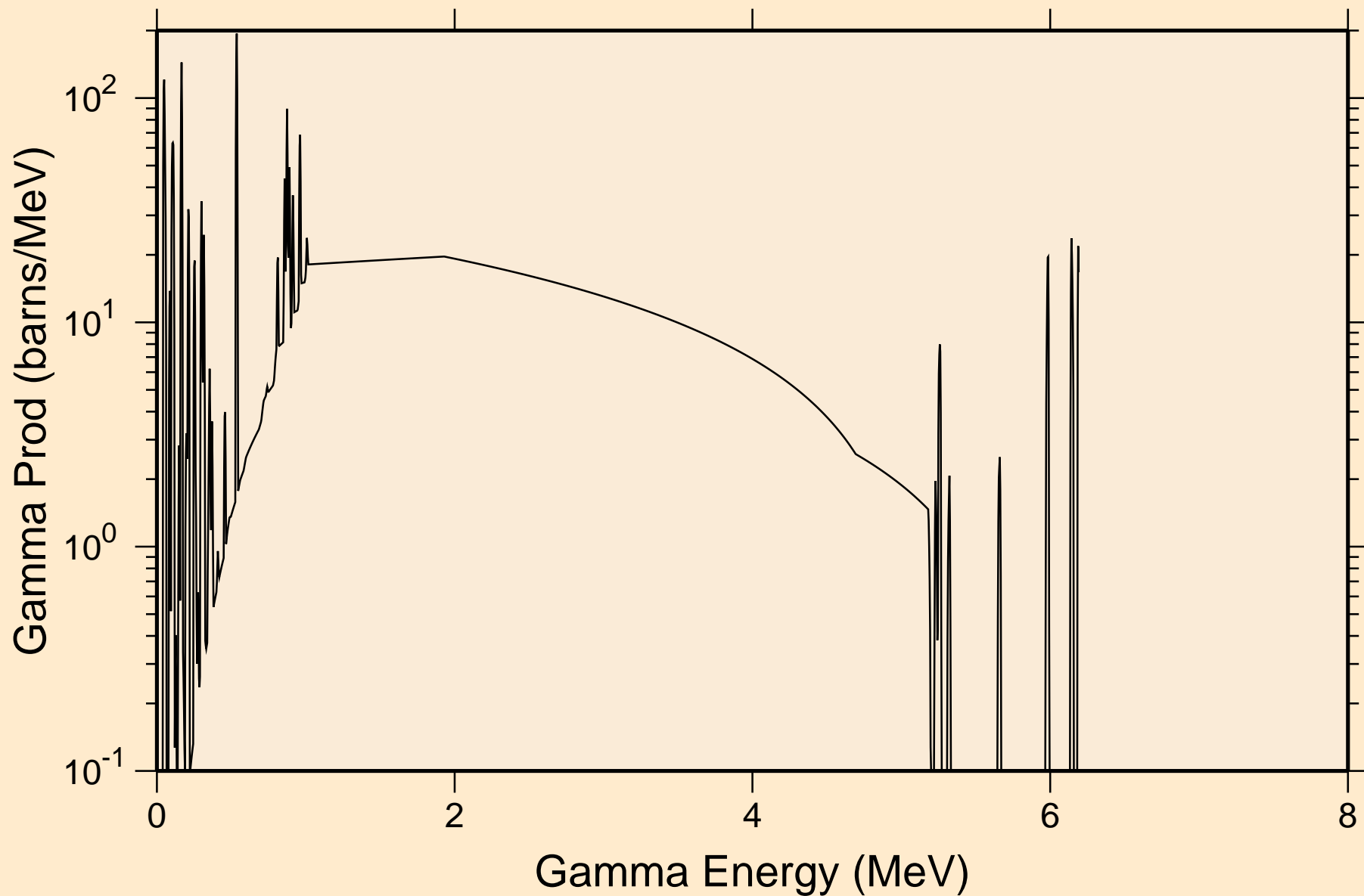

74-W-182 FROM INDL-2008 WITH NJOY99.259.NEA042, FEB. 200
14 MeV photon spectrum

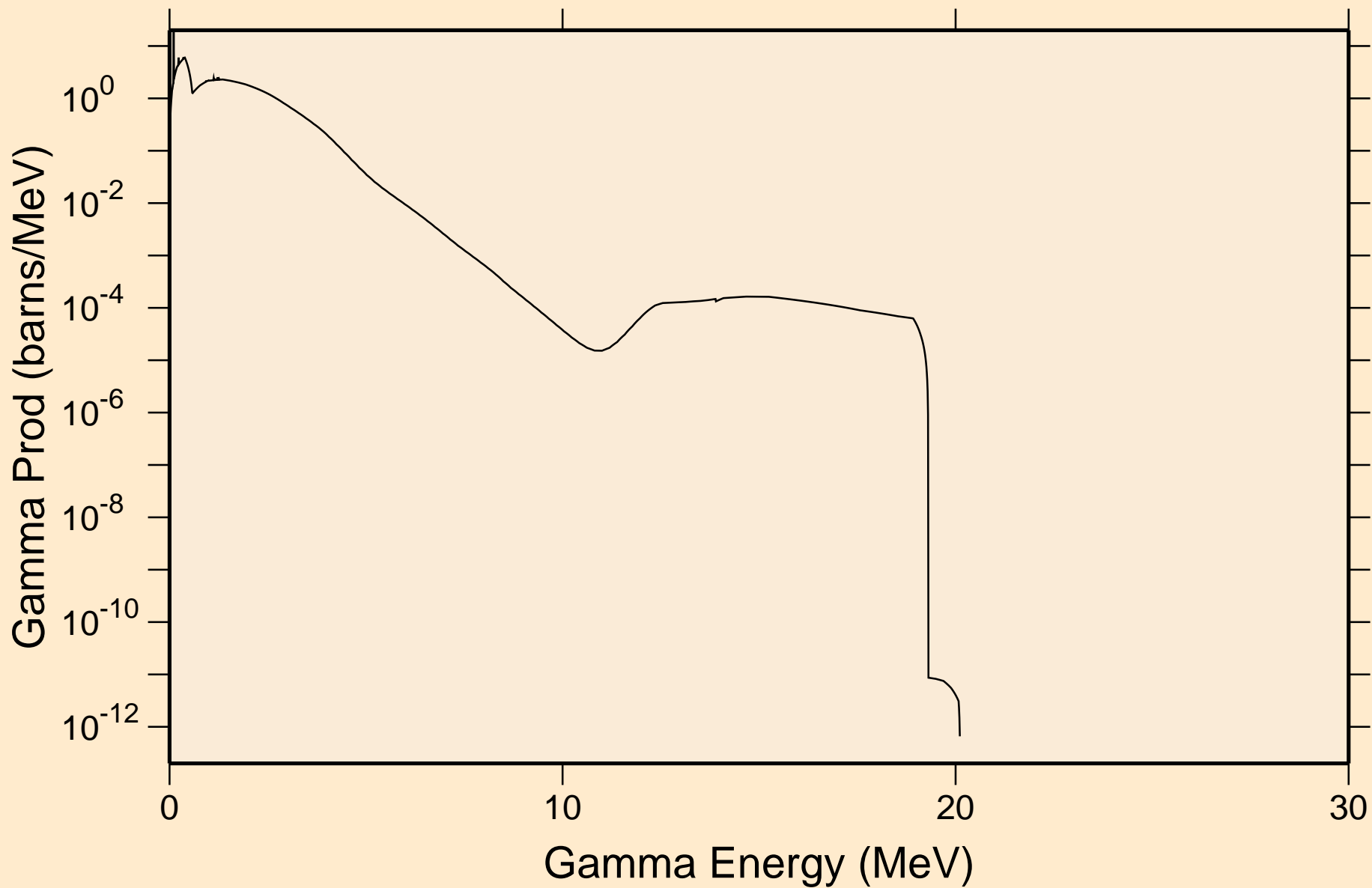

74-W-182 FROM INDL-2008 WITH NJOY99.259.NEA042, FEB. 200
Particle heating contributions

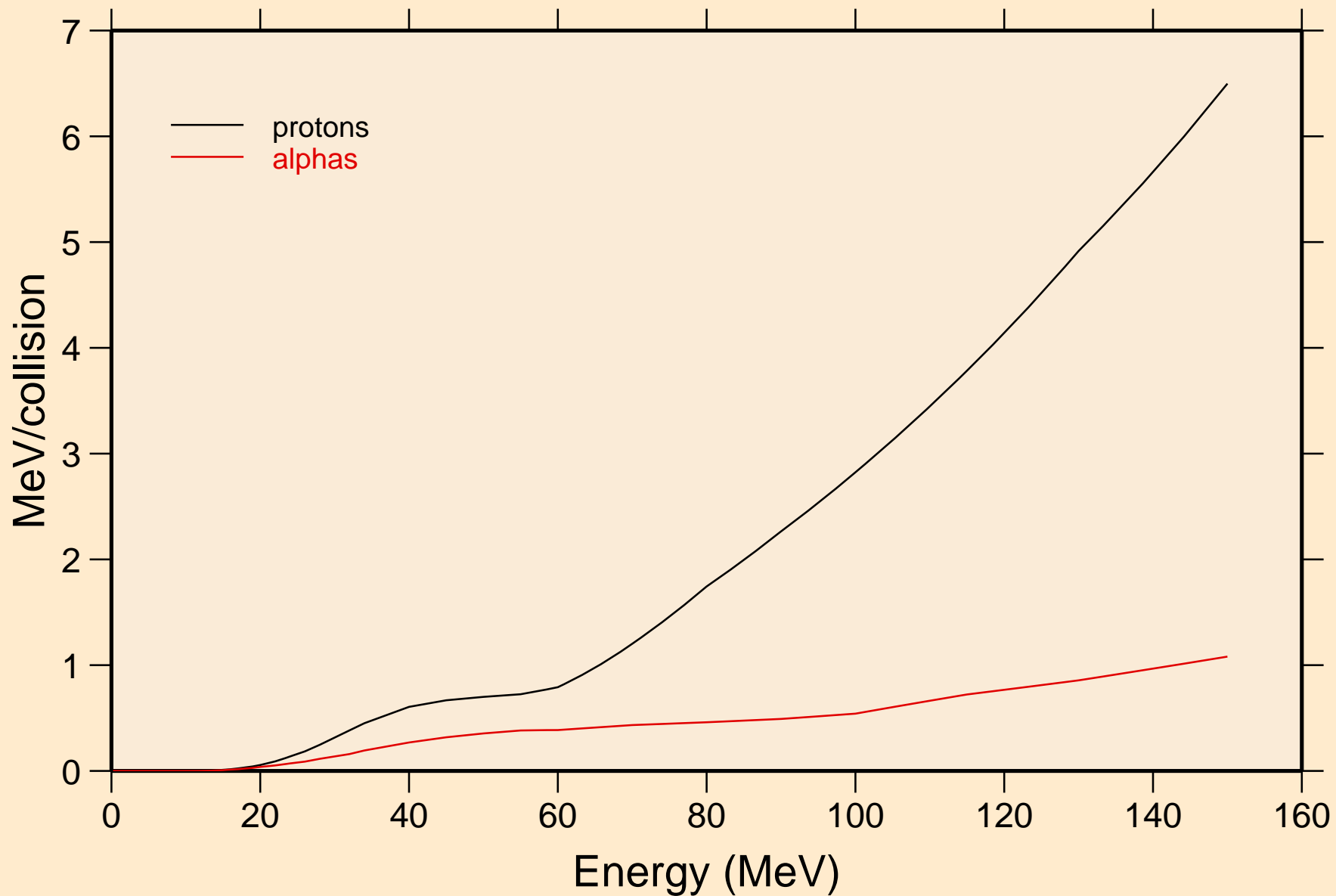

74-W-182 FROM INDL-2008 WITH NJOY99.259.NEA042, FEB. 200
Recoil Heating

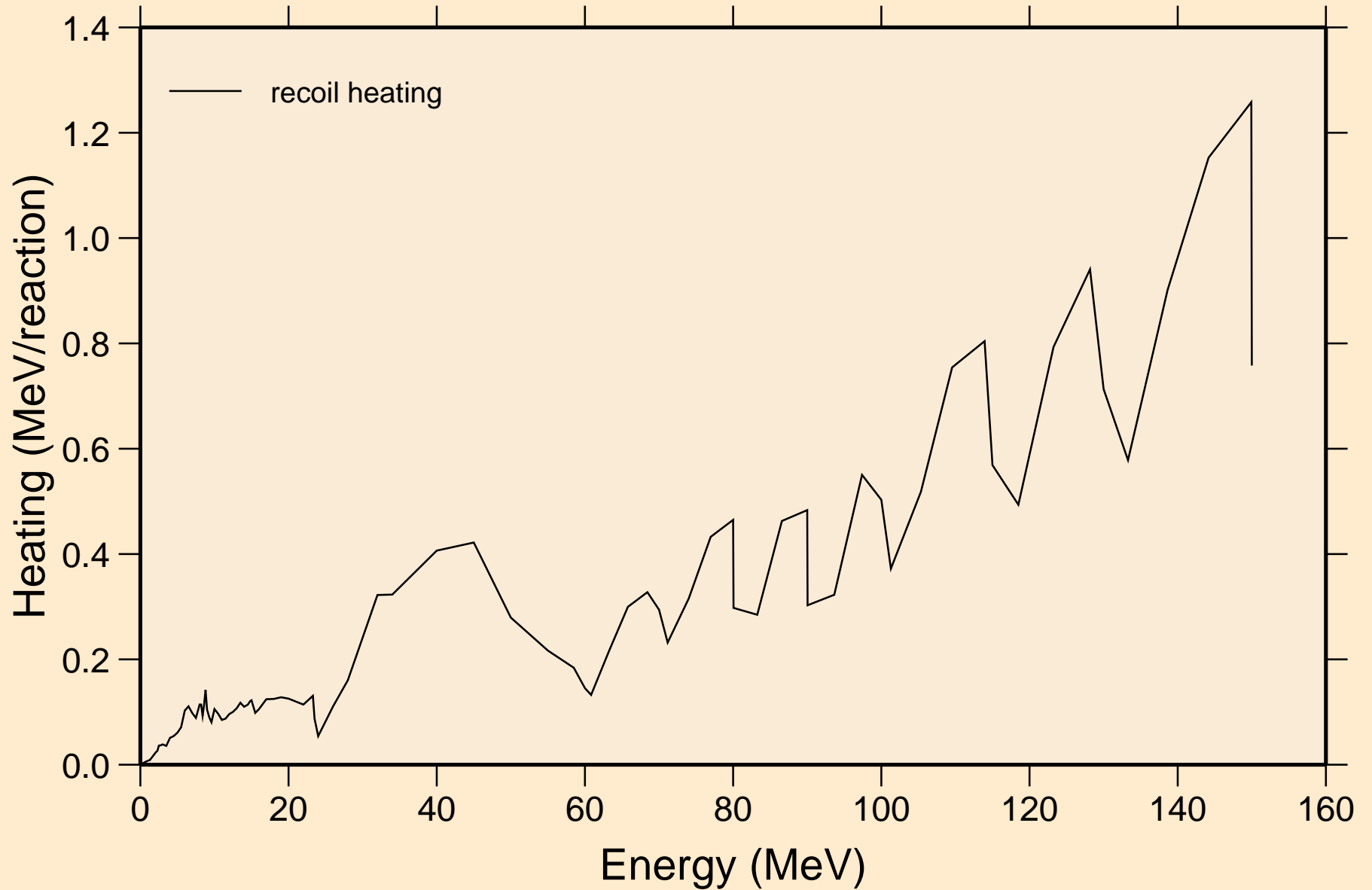

74-W-182 FROM INDL-2008 WITH NJOY99.259.NEA042, FEB. 200
Particle production cross sections

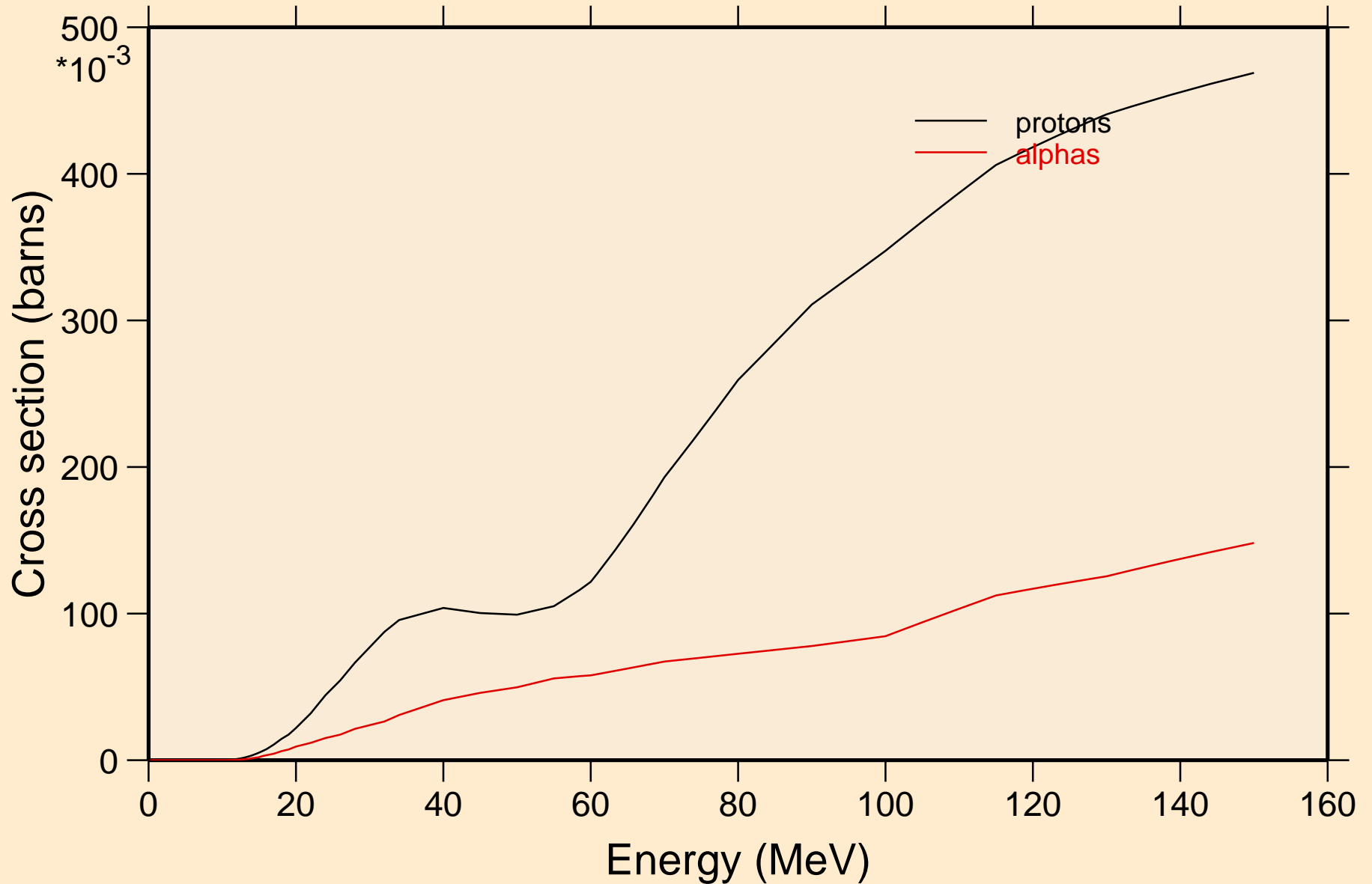

74-W-182 FROM INDL-2008 WITH NJOY99.259.NEA042, FEB. 200
protons from (n,x)

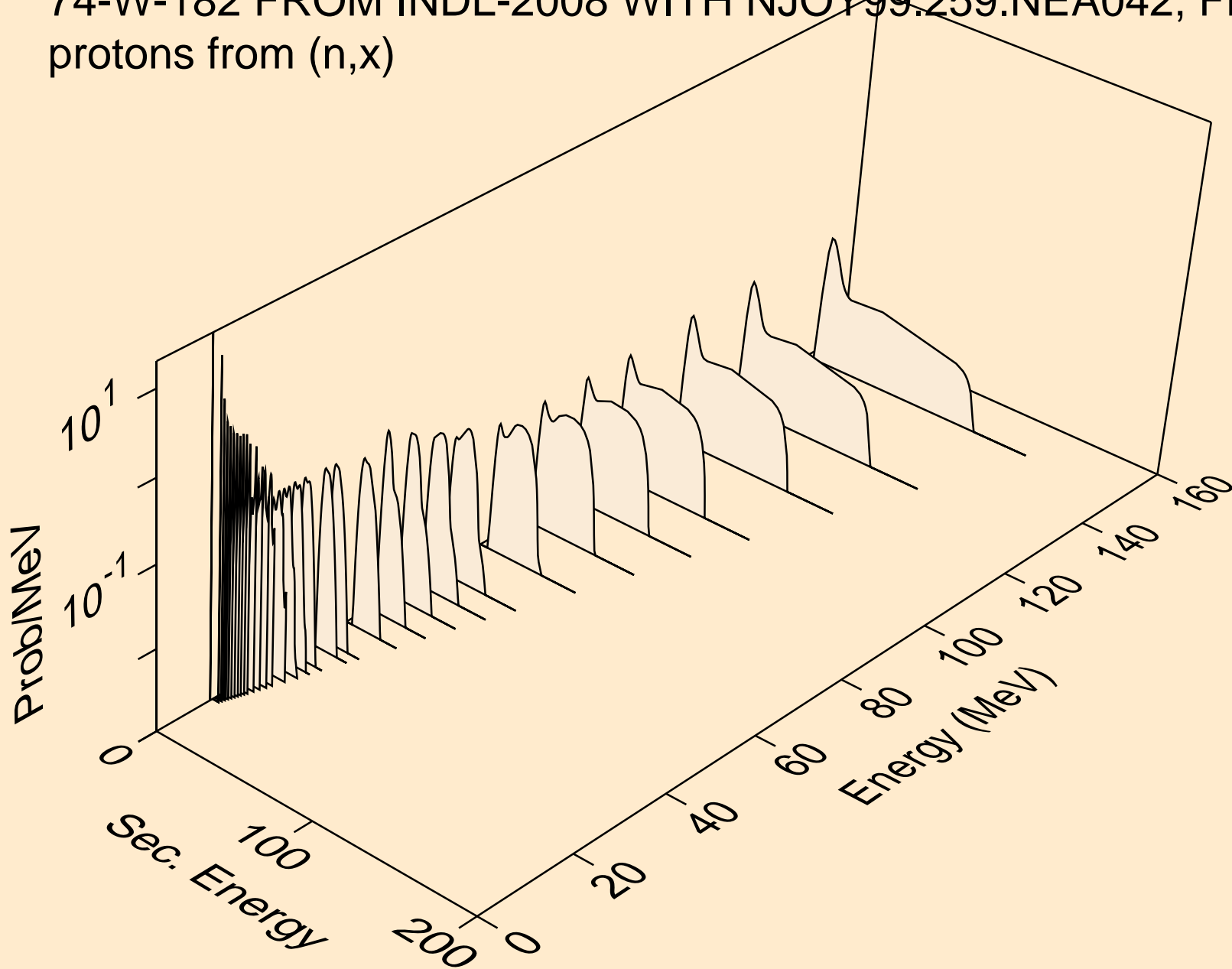

74-W-182 FROM INDL-2008 WITH NJOY99.259.NEA042, FEB. 200
protons from (n,n*)p

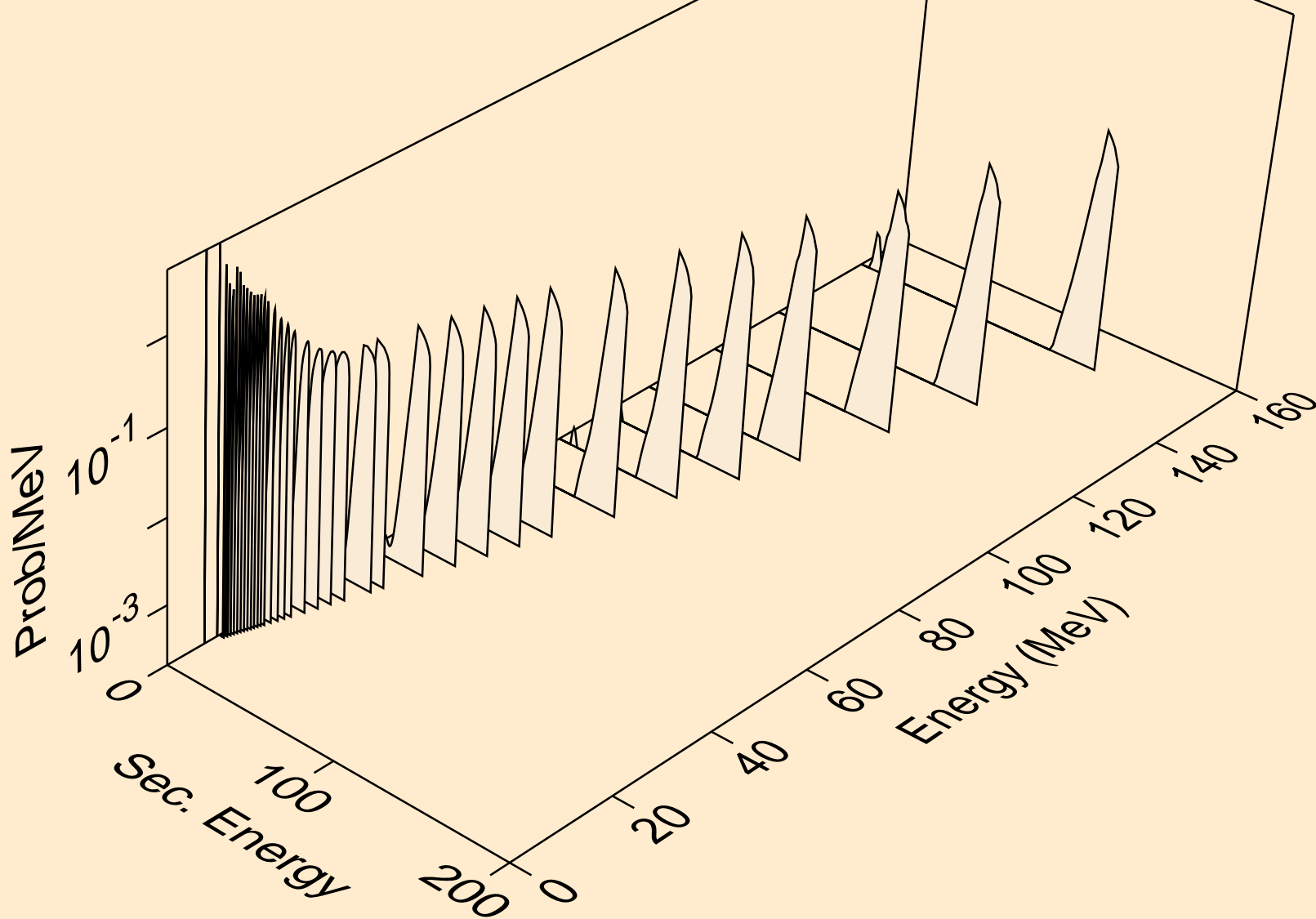

74-W-182 FROM INDL-2008 WITH NJOY99.259.NEA042, FEB. 200
protons from (n,2np)

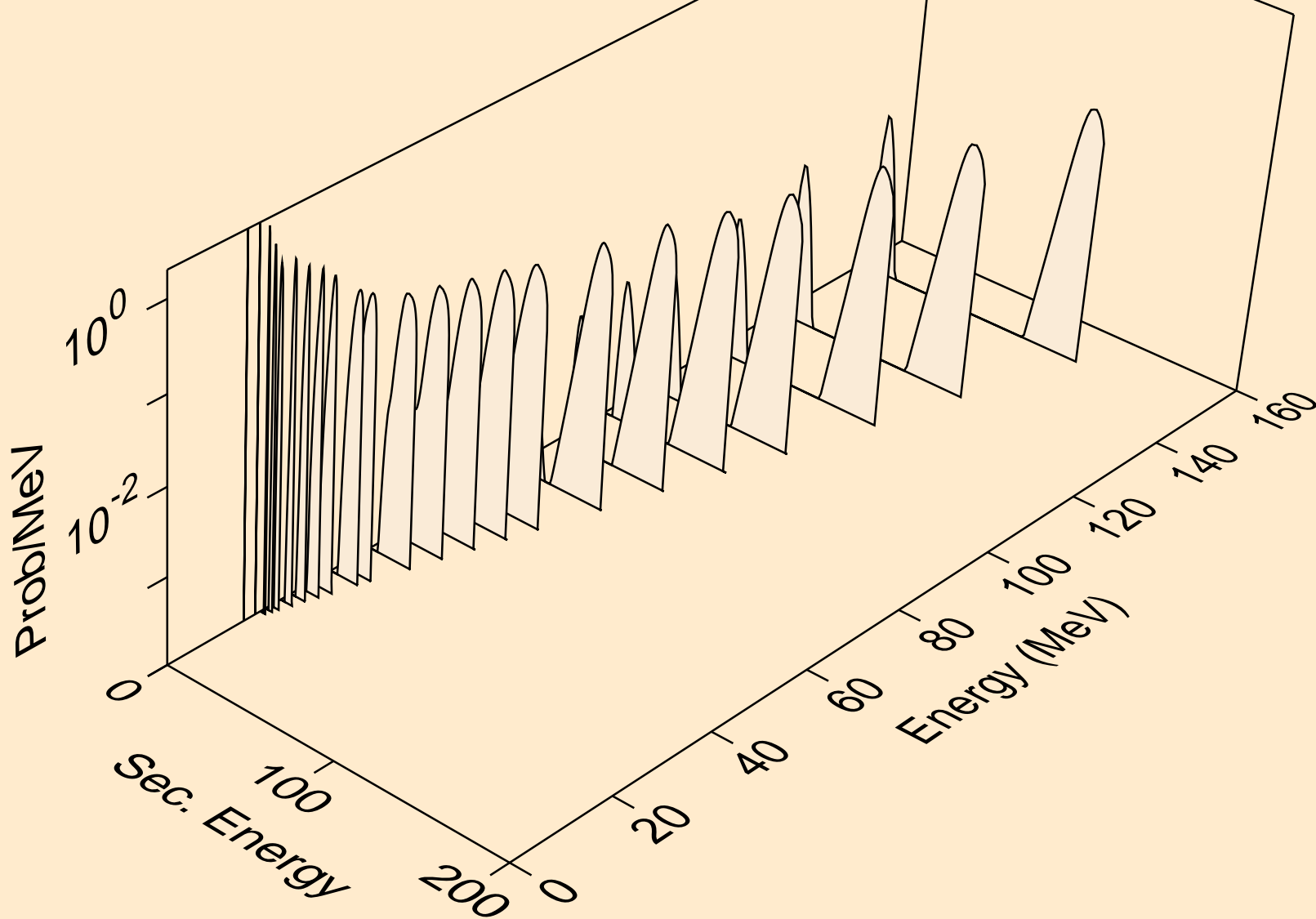

74-W-182 FROM INDL-2008 WITH NJOY99.259.NEA042, FEB. 200
angular distribution for (n,p*0) proton

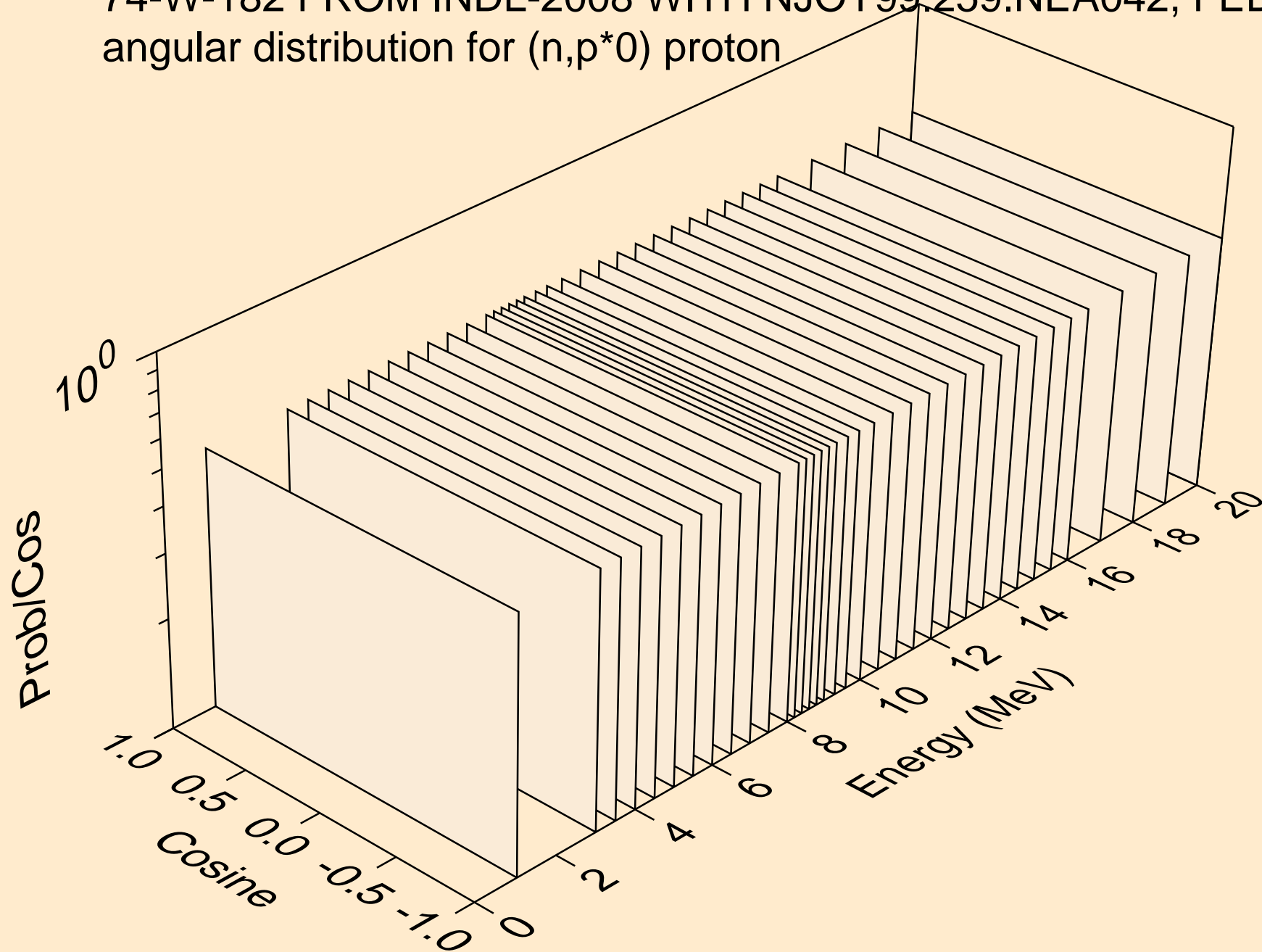

74-W-182 FROM INDL-2008 WITH NJOY99.259.NEA042, FEB. 200
angular distribution for (n,p*0) proton

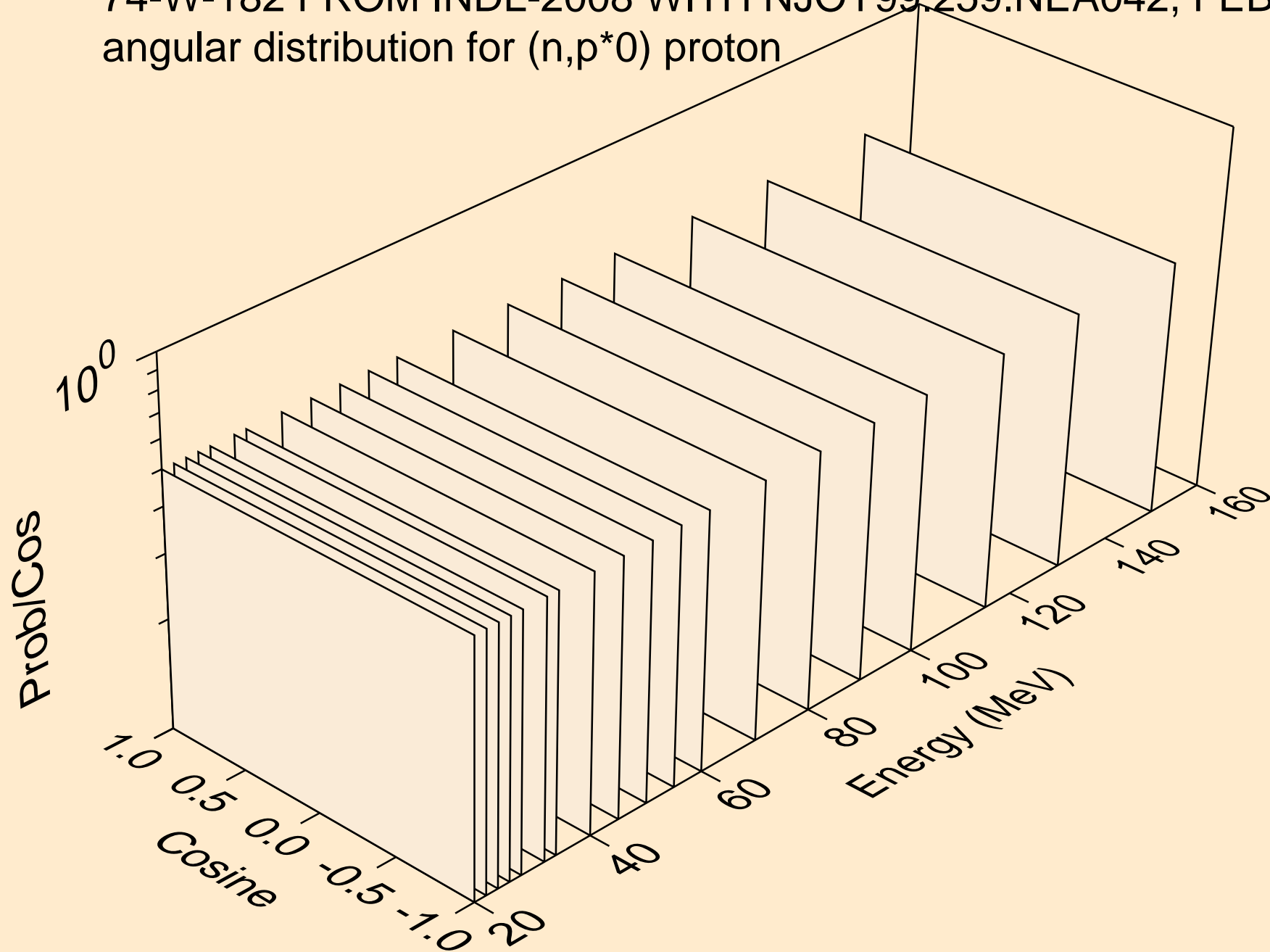

74-W-182 FROM INDL-2008 WITH NJOY99.259.NEA042, FEB. 200
angular distribution for (n,p*1) proton

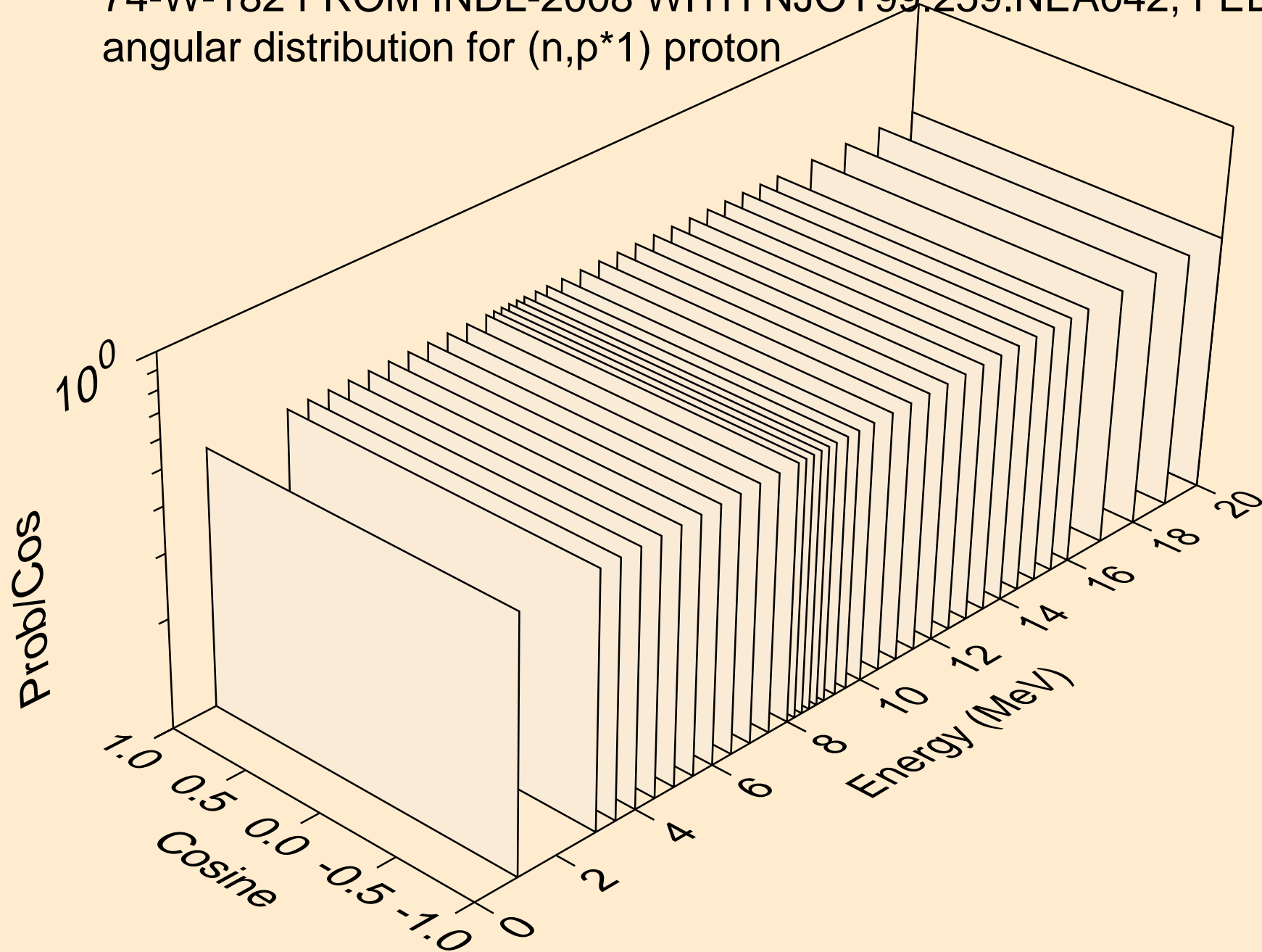

74-W-182 FROM INDL-2008 WITH NJOY99.259.NEA042, FEB. 200
angular distribution for (n,p*1) proton

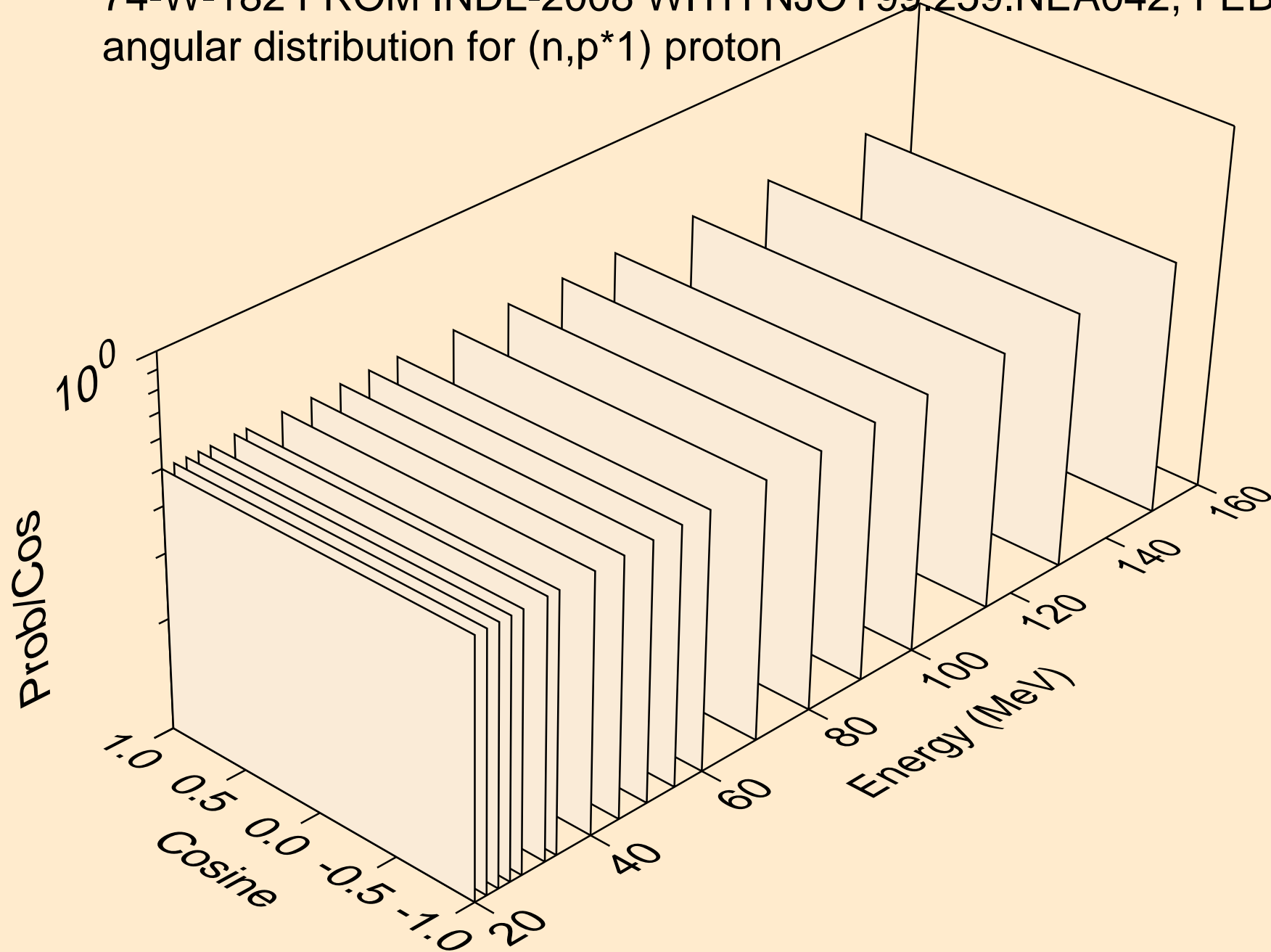

74-W-182 FROM INDL-2008 WITH NJOY99.259.NEA042, FEB. 200
angular distribution for (n,p*2) proton

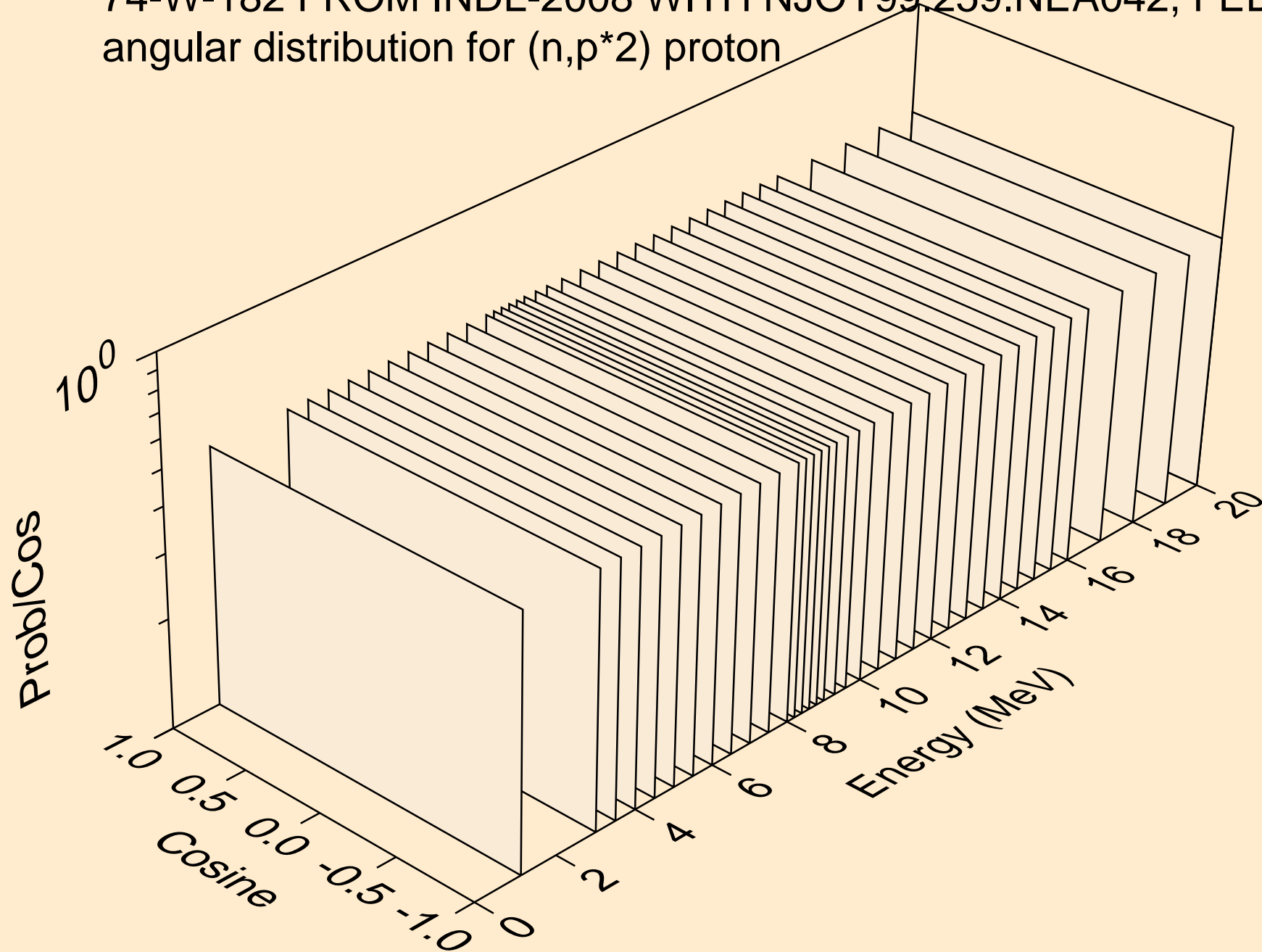

74-W-182 FROM INDL-2008 WITH NJOY99.259.NEA042, FEB. 200
angular distribution for (n,p*2) proton

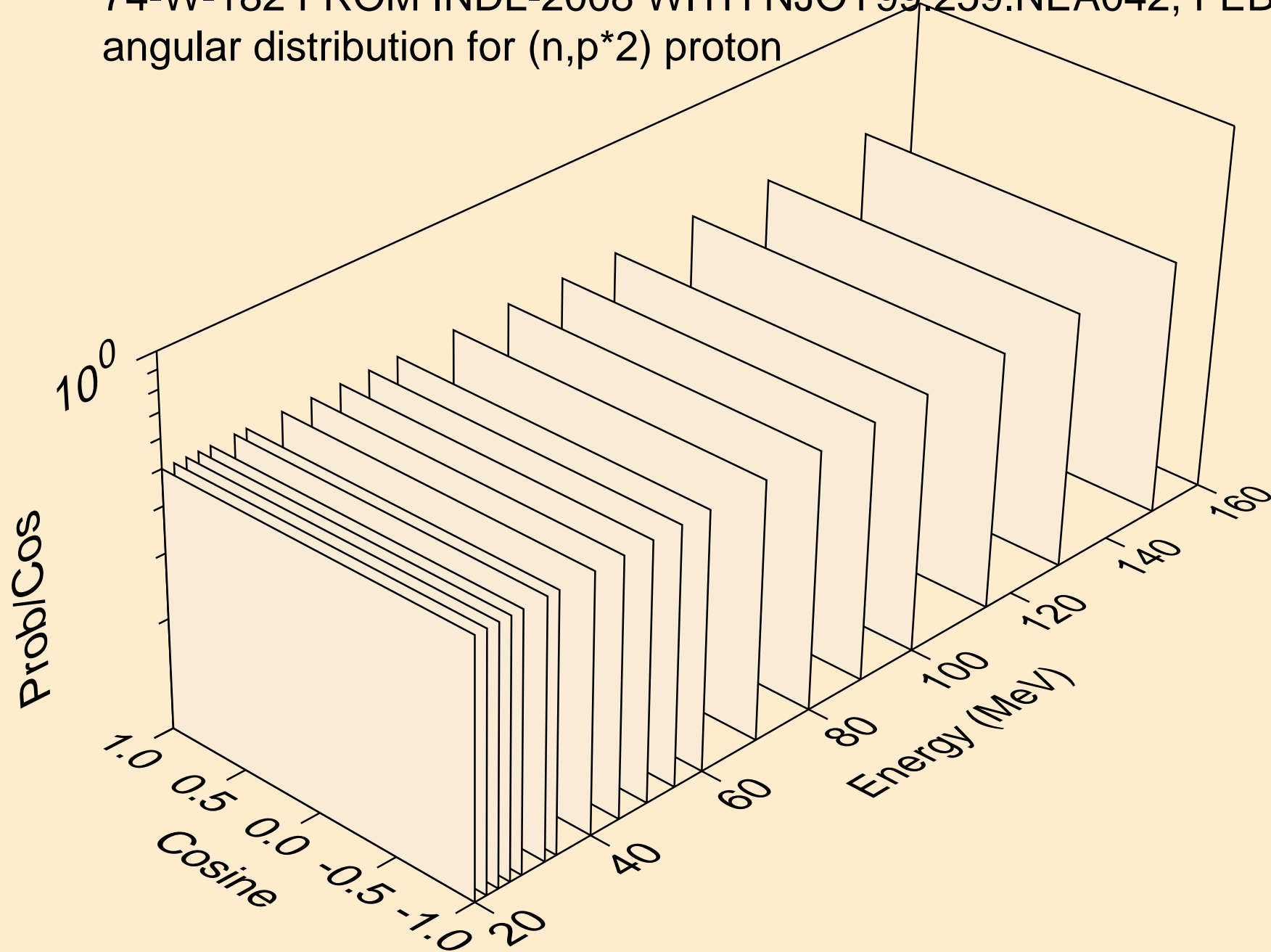

74-W-182 FROM INDL-2008 WITH NJOY99.259.NEA042, FEB. 200
angular distribution for (n,p*3) proton

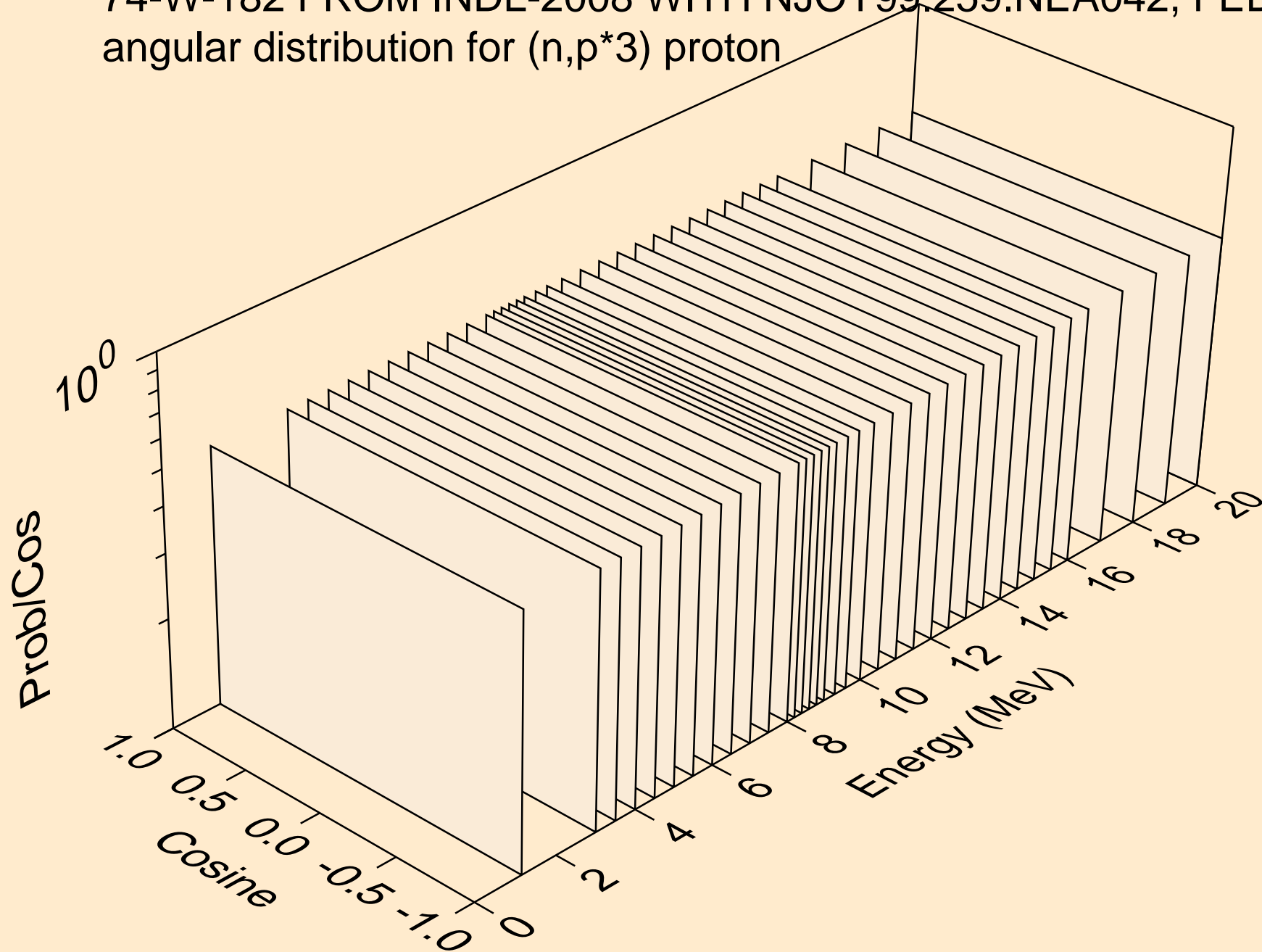

74-W-182 FROM INDL-2008 WITH NJOY99.259.NEA042, FEB. 200
angular distribution for (n,p*3) proton

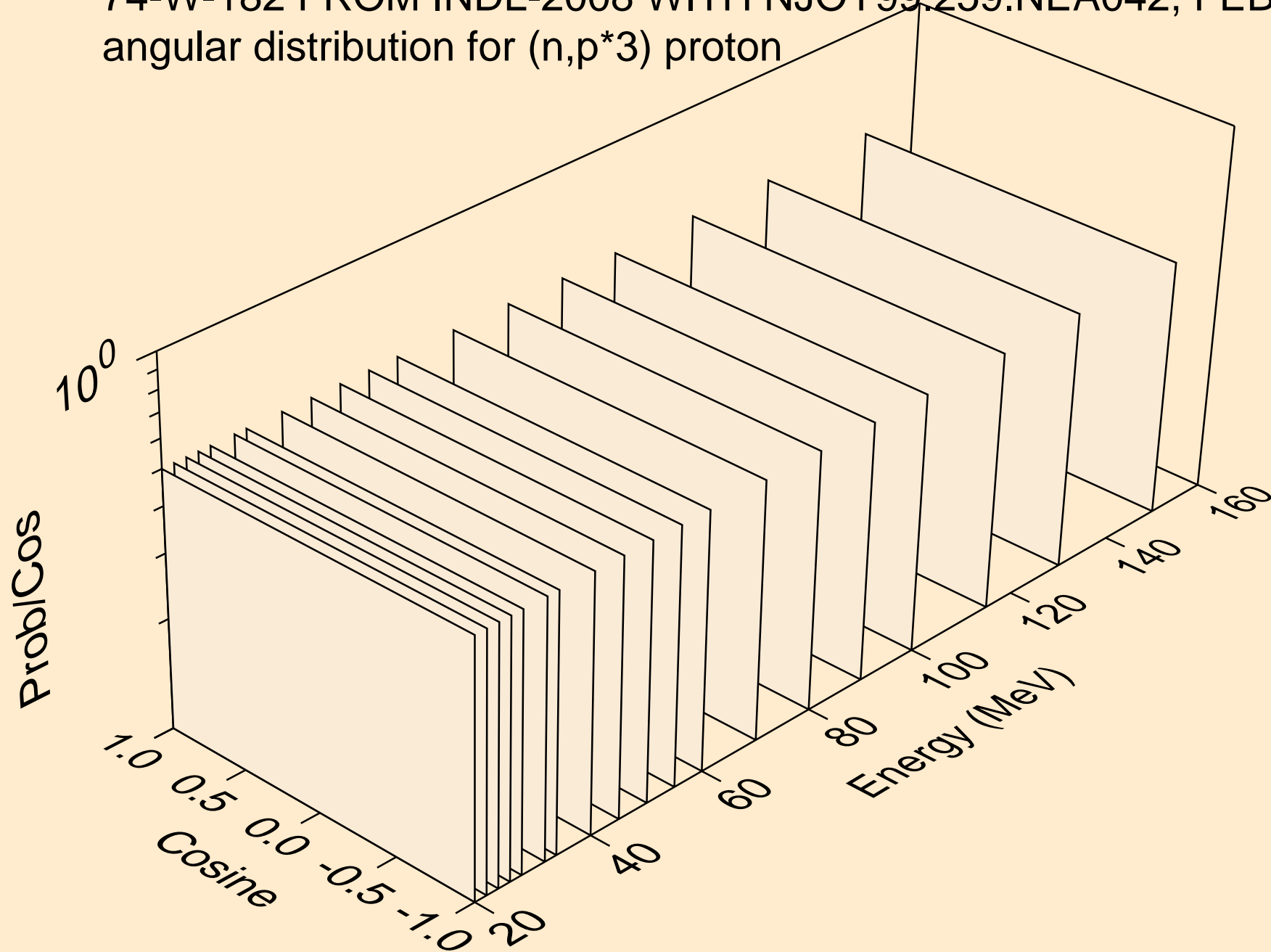

74-W-182 FROM INDL-2008 WITH NJOY99.259.NEA042, FEB. 200
angular distribution for (n,p*4) proton

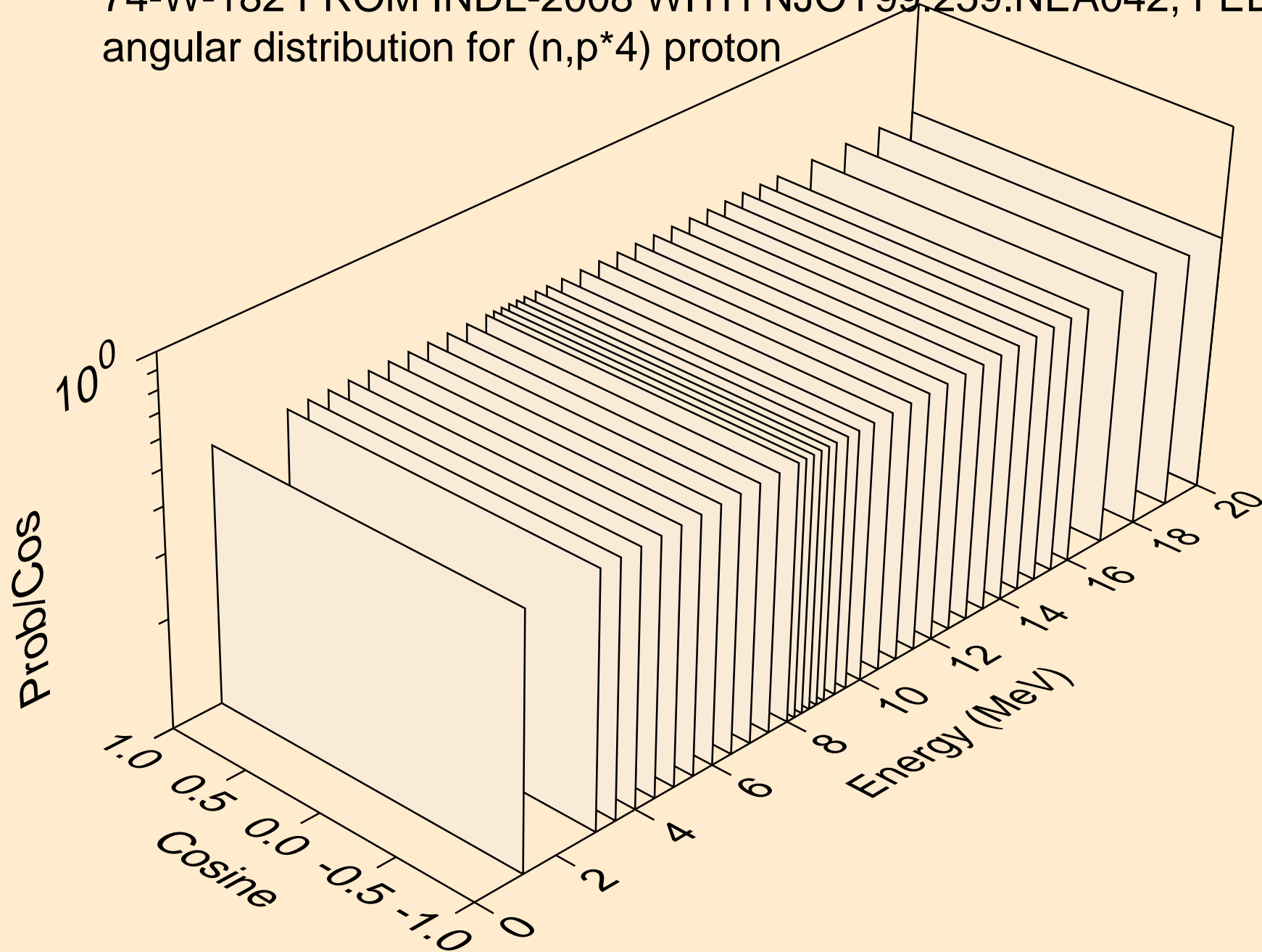

74-W-182 FROM INDL-2008 WITH NJOY99.259.NEA042, FEB. 200
angular distribution for (n,p*4) proton

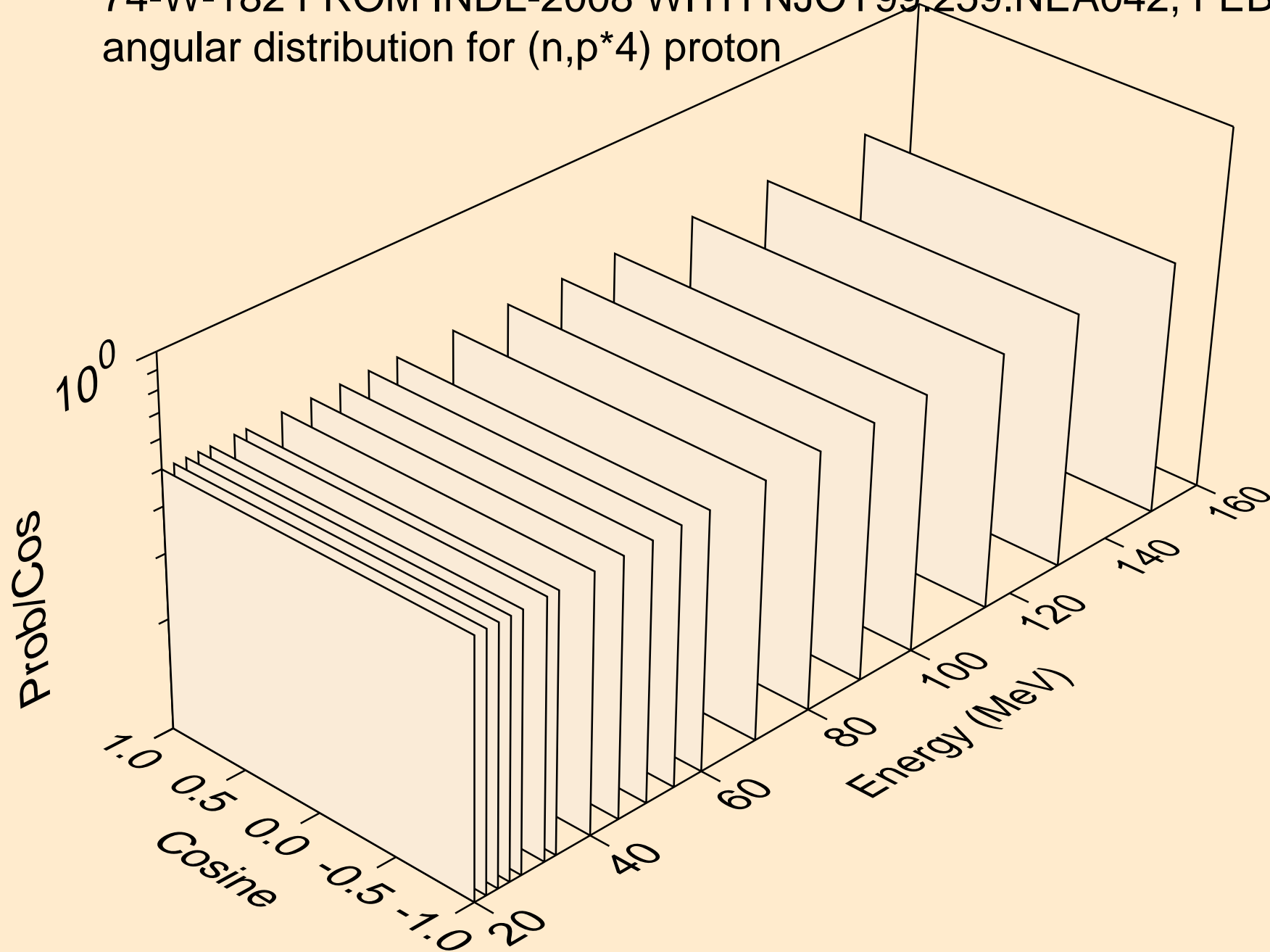

74-W-182 FROM INDL-2008 WITH NJOY99.259.NEA042, FEB. 200
angular distribution for (n,p*5) proton

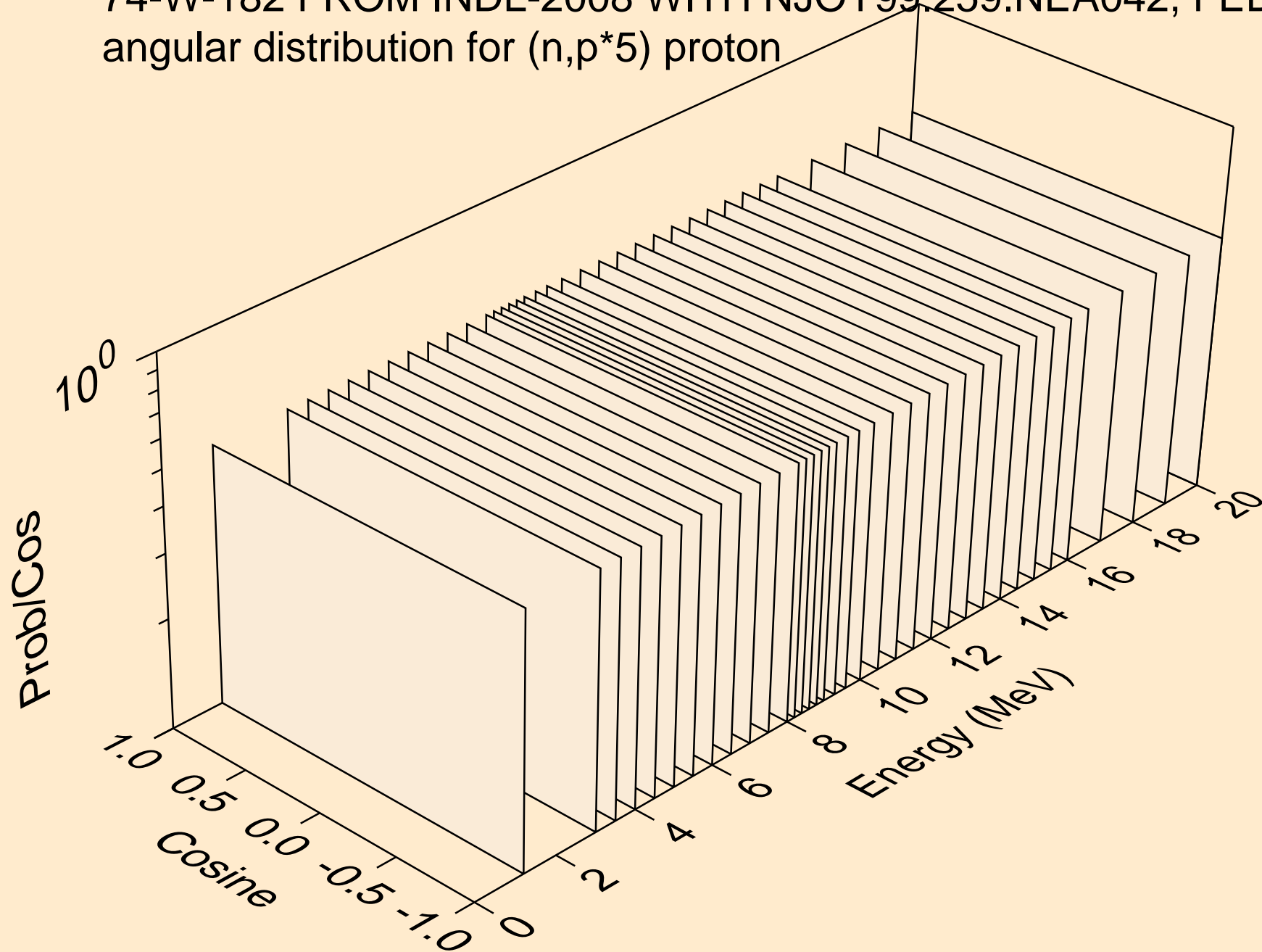

74-W-182 FROM INDL-2008 WITH NJOY99.259.NEA042, FEB. 200
angular distribution for (n,p*5) proton

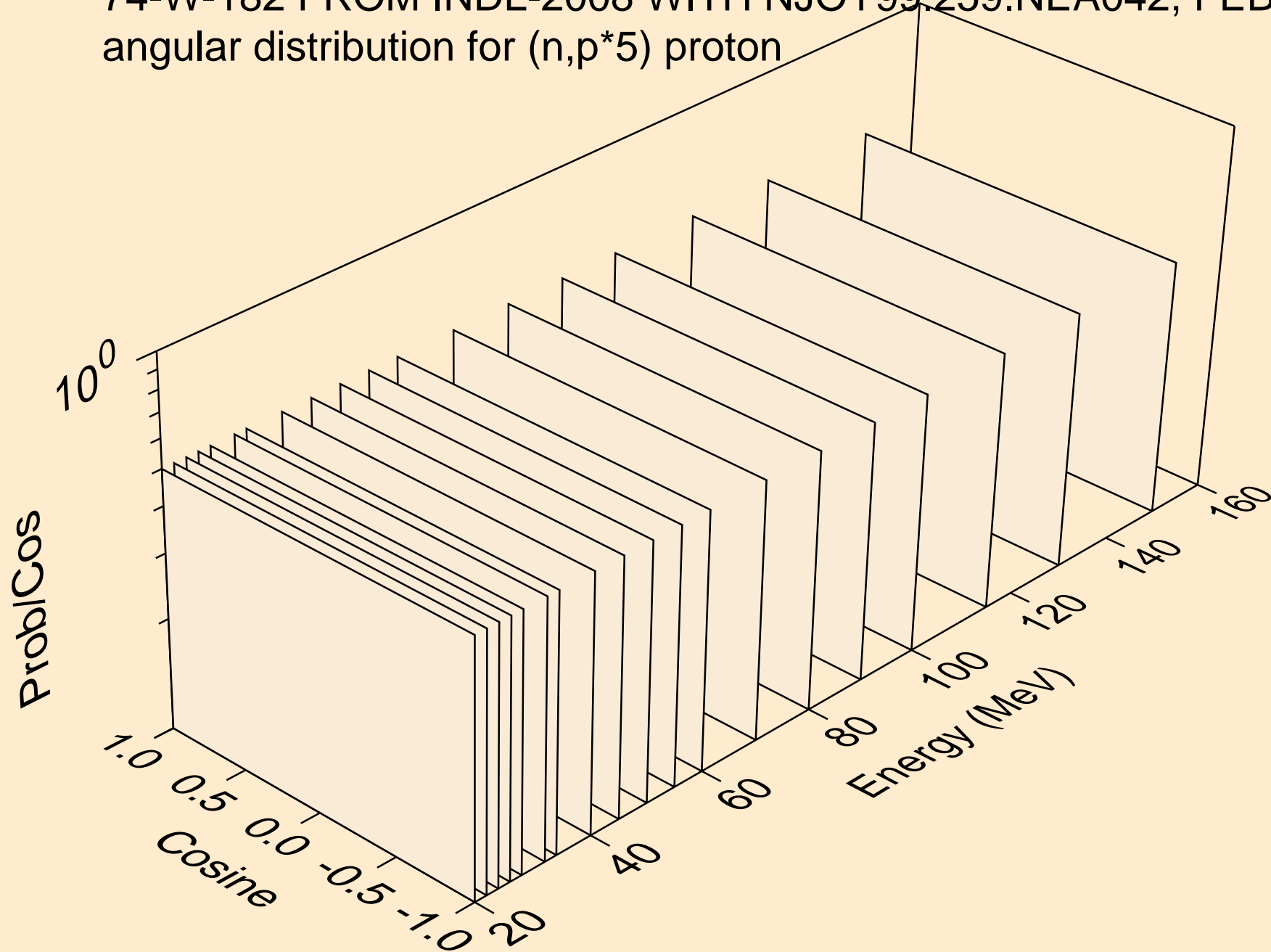

74-W-182 FROM INDL-2008 WITH NJOY99.259.NEA042, FEB. 200
angular distribution for (n,p*6) proton

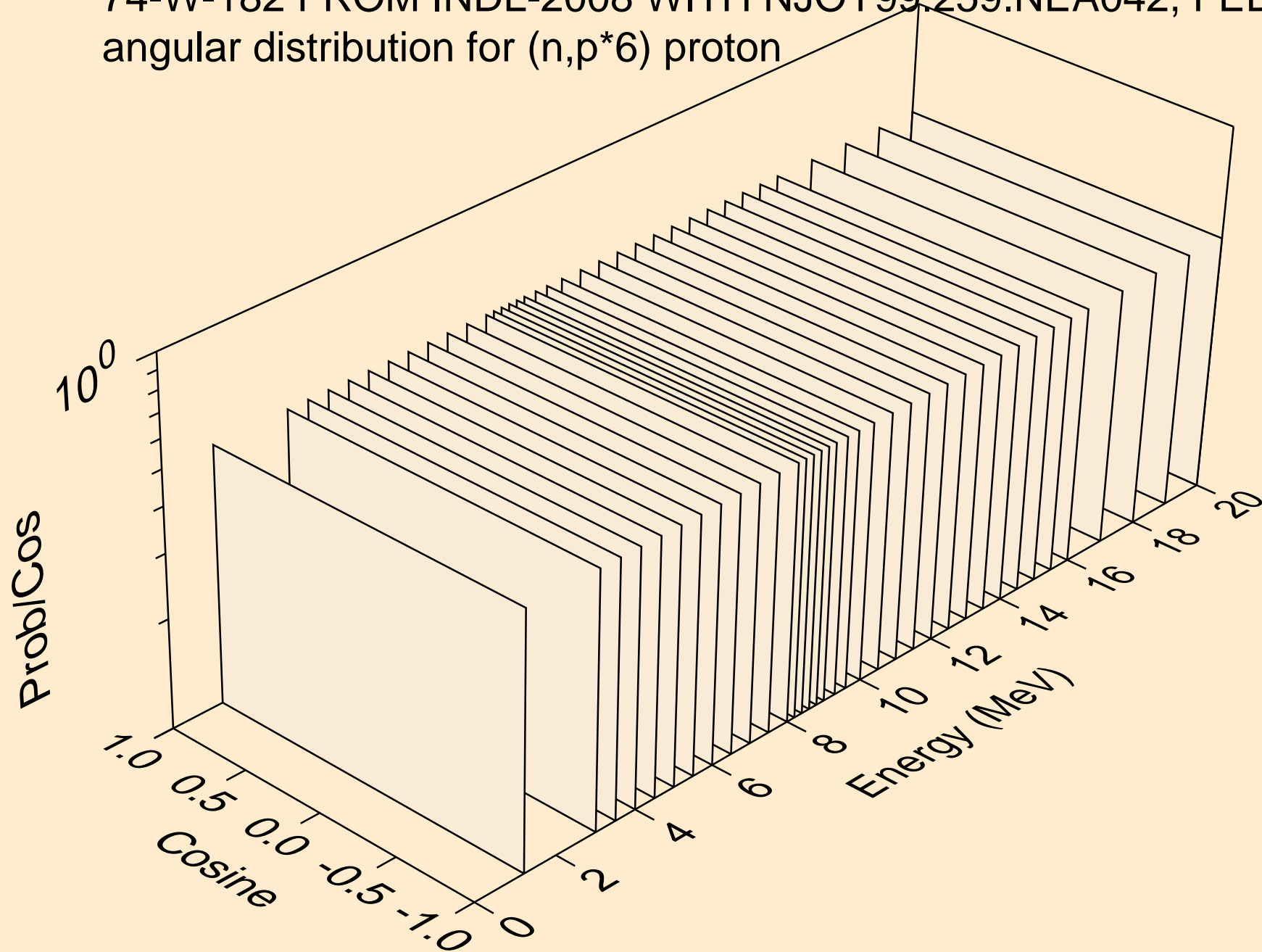

74-W-182 FROM INDL-2008 WITH NJOY99.259.NEA042, FEB. 200
angular distribution for (n,p*6) proton

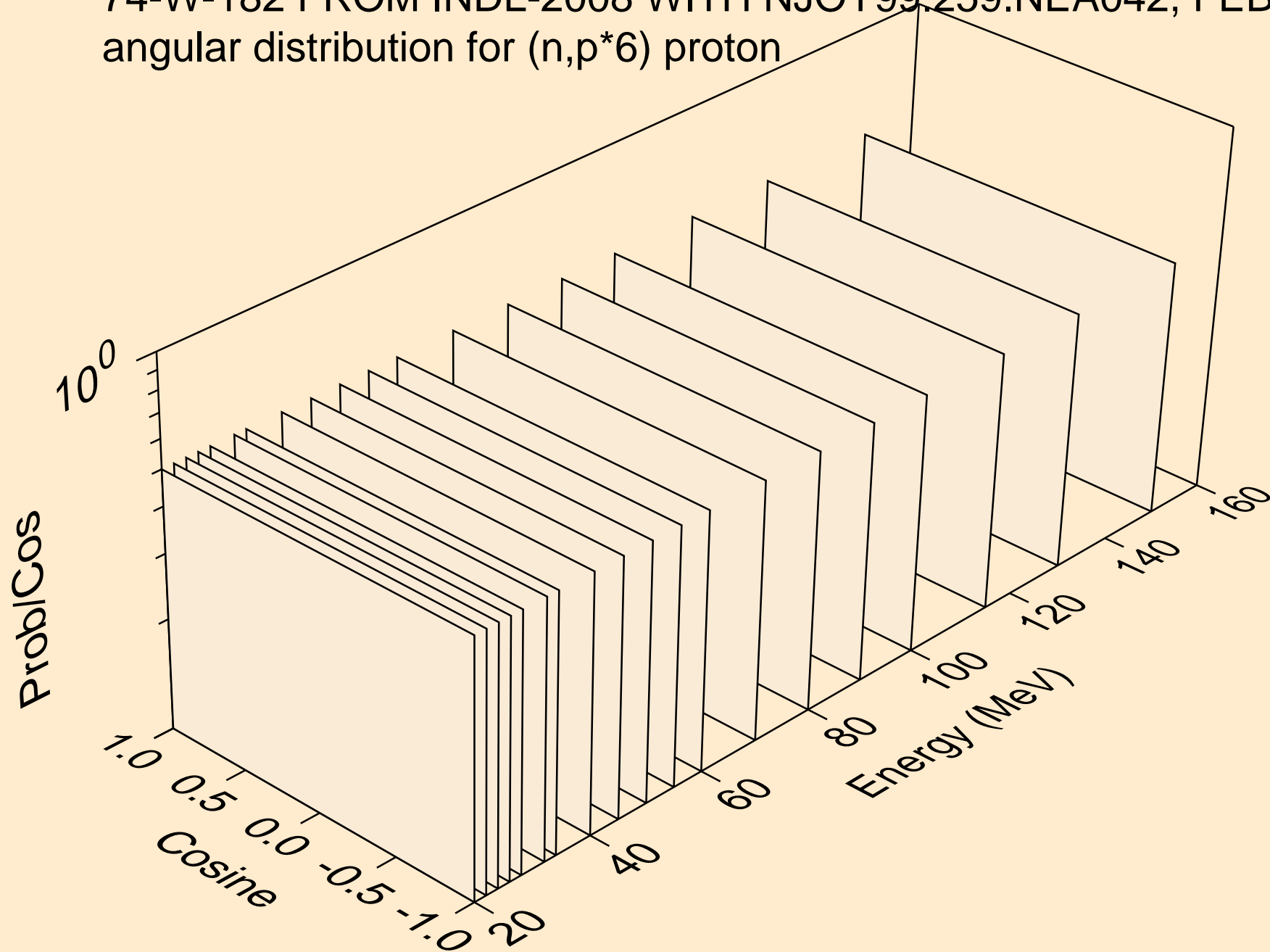

74-W-182 FROM INDL-2008 WITH NJOY99.259.NEA042, FEB. 200
angular distribution for (n,p*7) proton

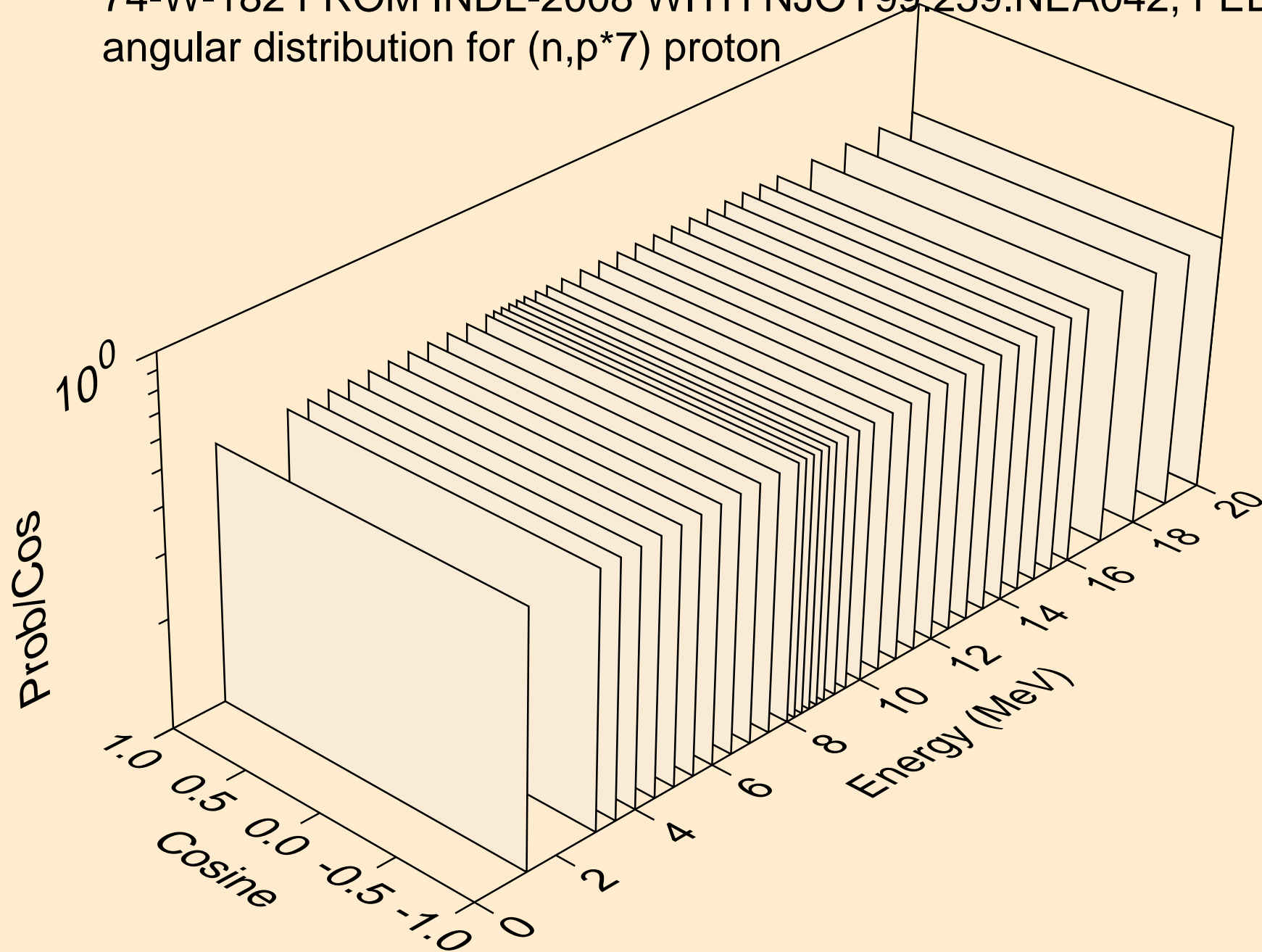

74-W-182 FROM INDL-2008 WITH NJOY99.259.NEA042, FEB. 200
angular distribution for (n,p*7) proton

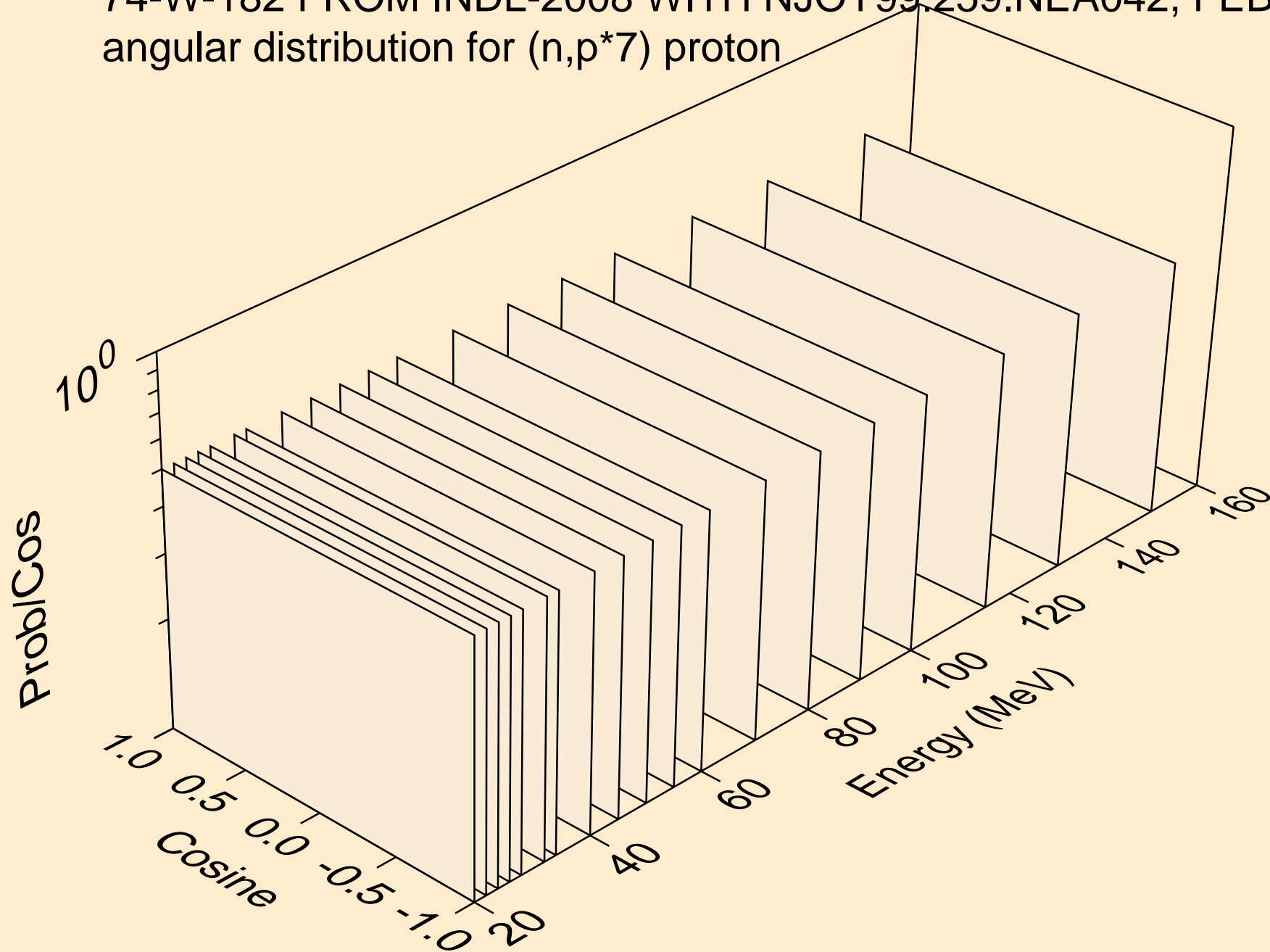

74-W-182 FROM INDL-2008 WITH NJOY99.259.NEA042, FEB. 200
angular distribution for (n,p*8) proton

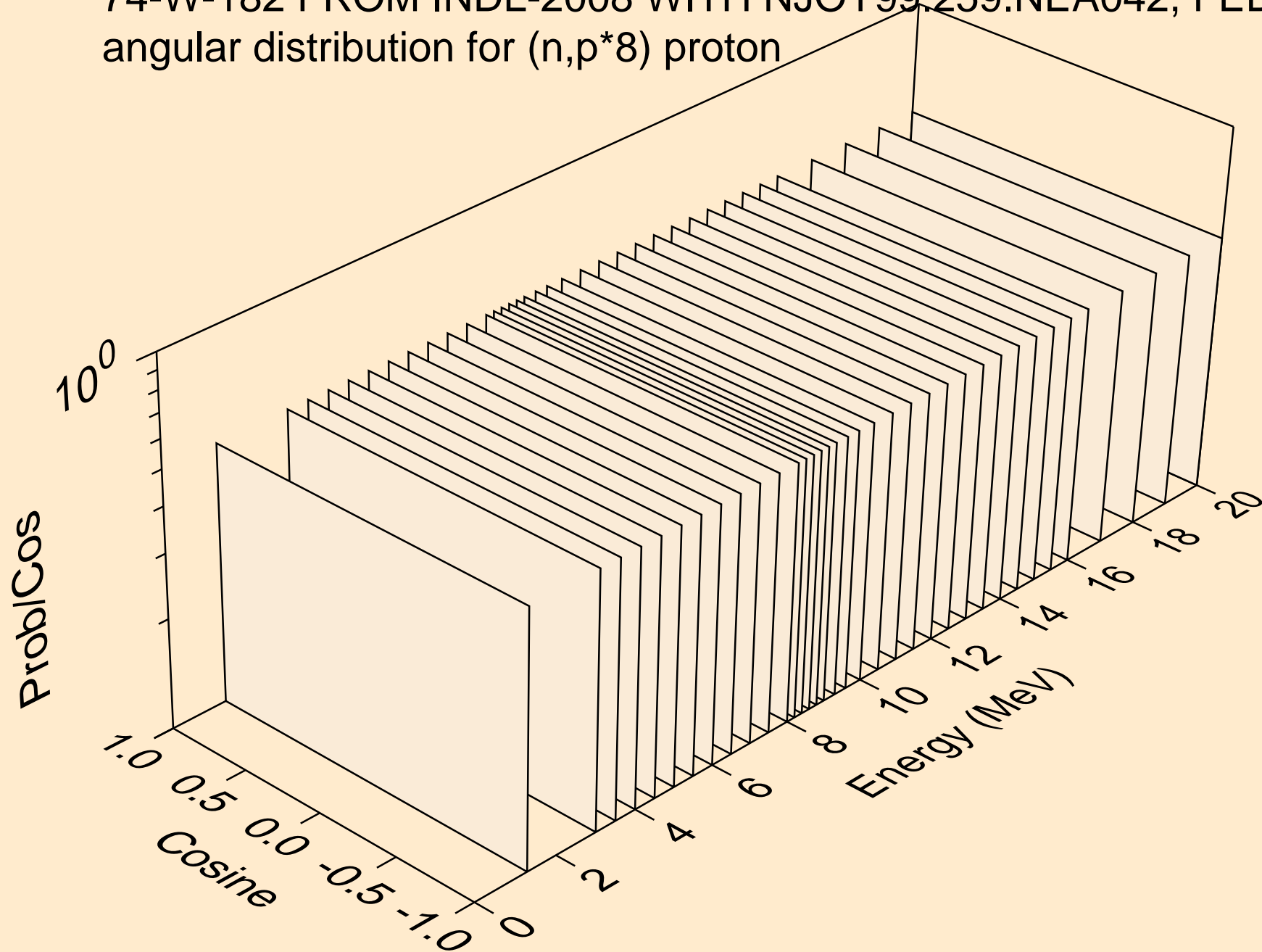

74-W-182 FROM INDL-2008 WITH NJOY99.259.NEA042, FEB. 200
angular distribution for (n,p*8) proton

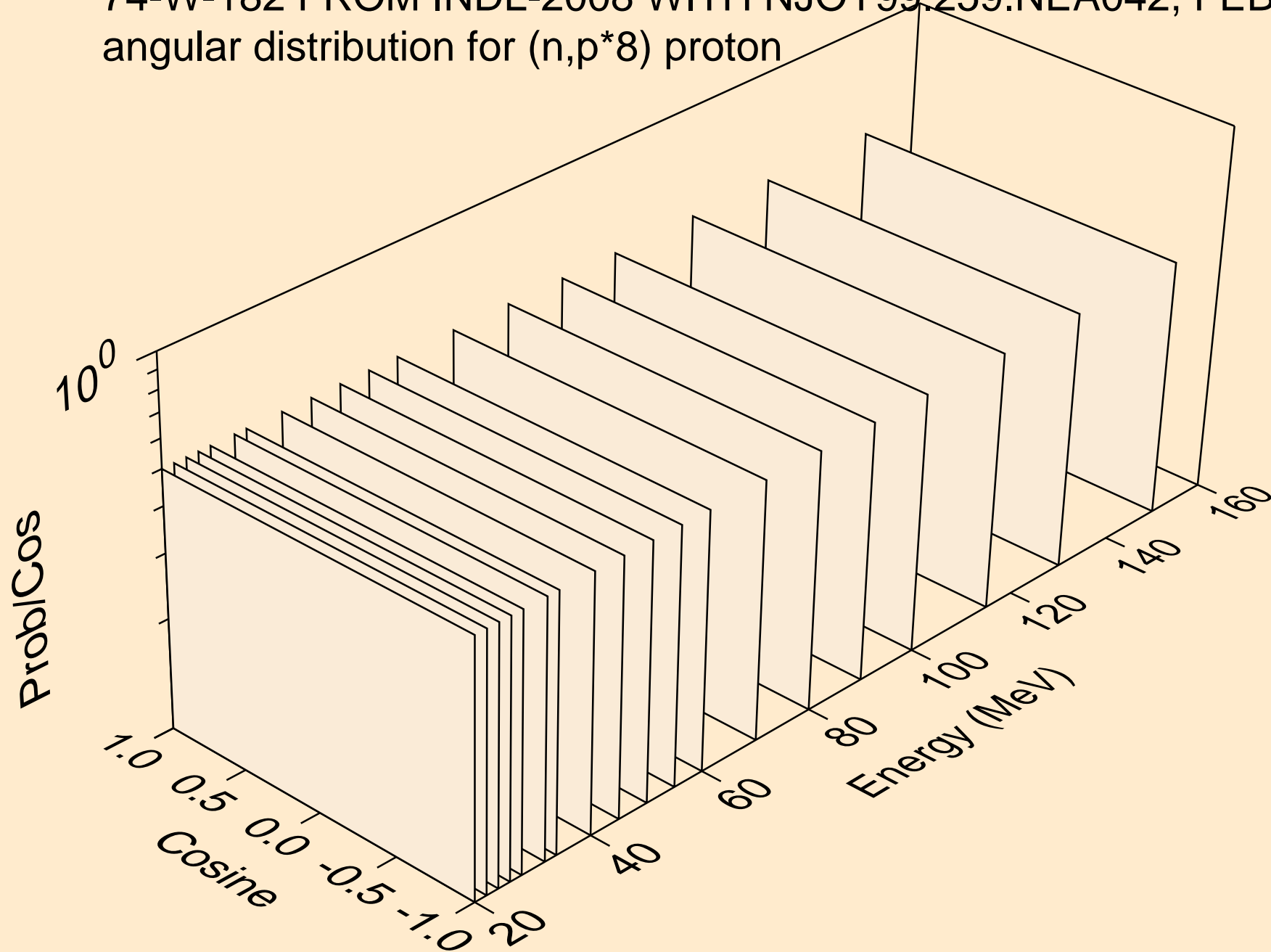

74-W-182 FROM INDL-2008 WITH NJOY99.259.NEA042, FEB. 200
angular distribution for (n,p*9) proton

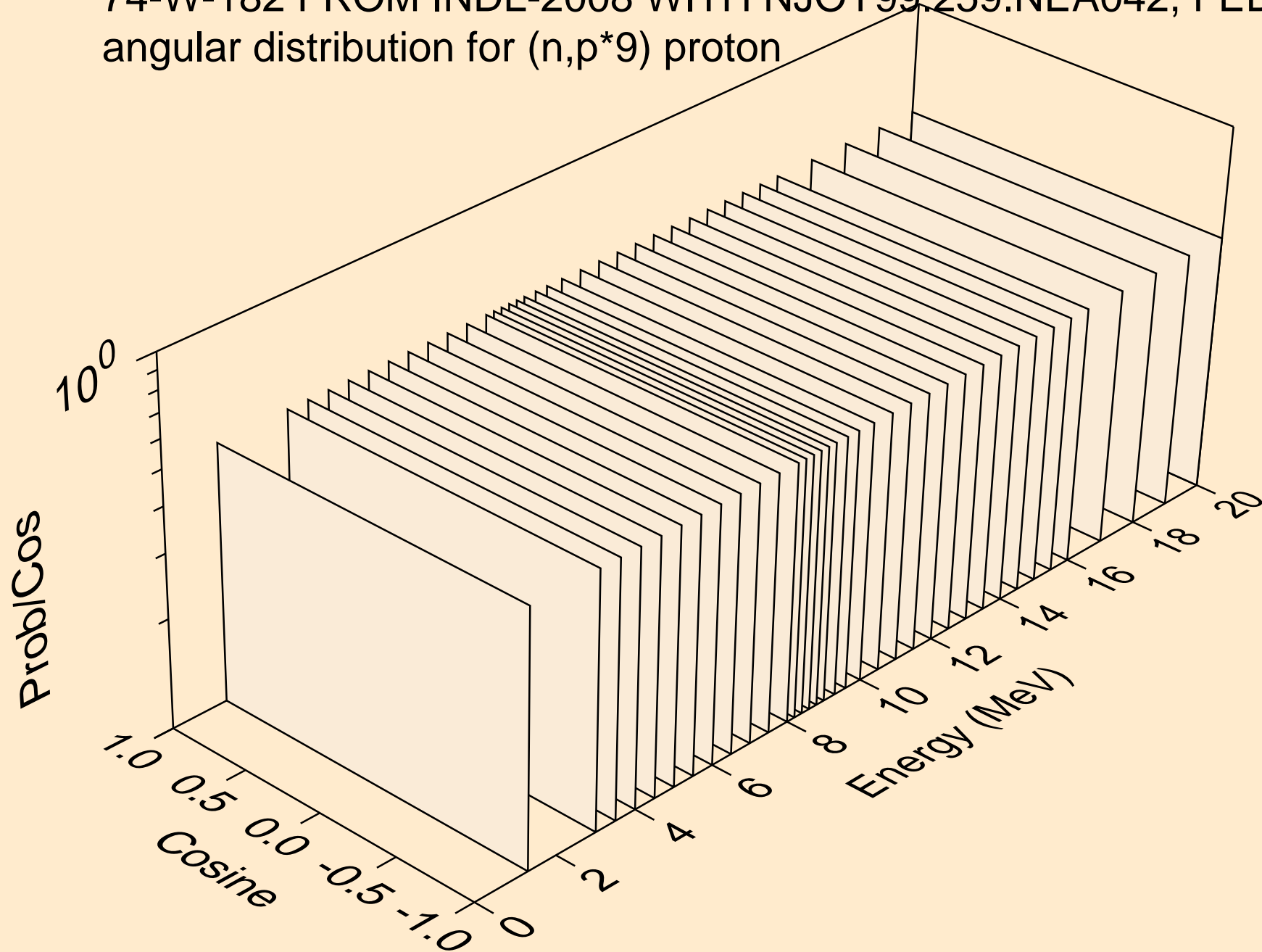

74-W-182 FROM INDL-2008 WITH NJOY99.259.NEA042, FEB. 200
angular distribution for (n,p*9) proton

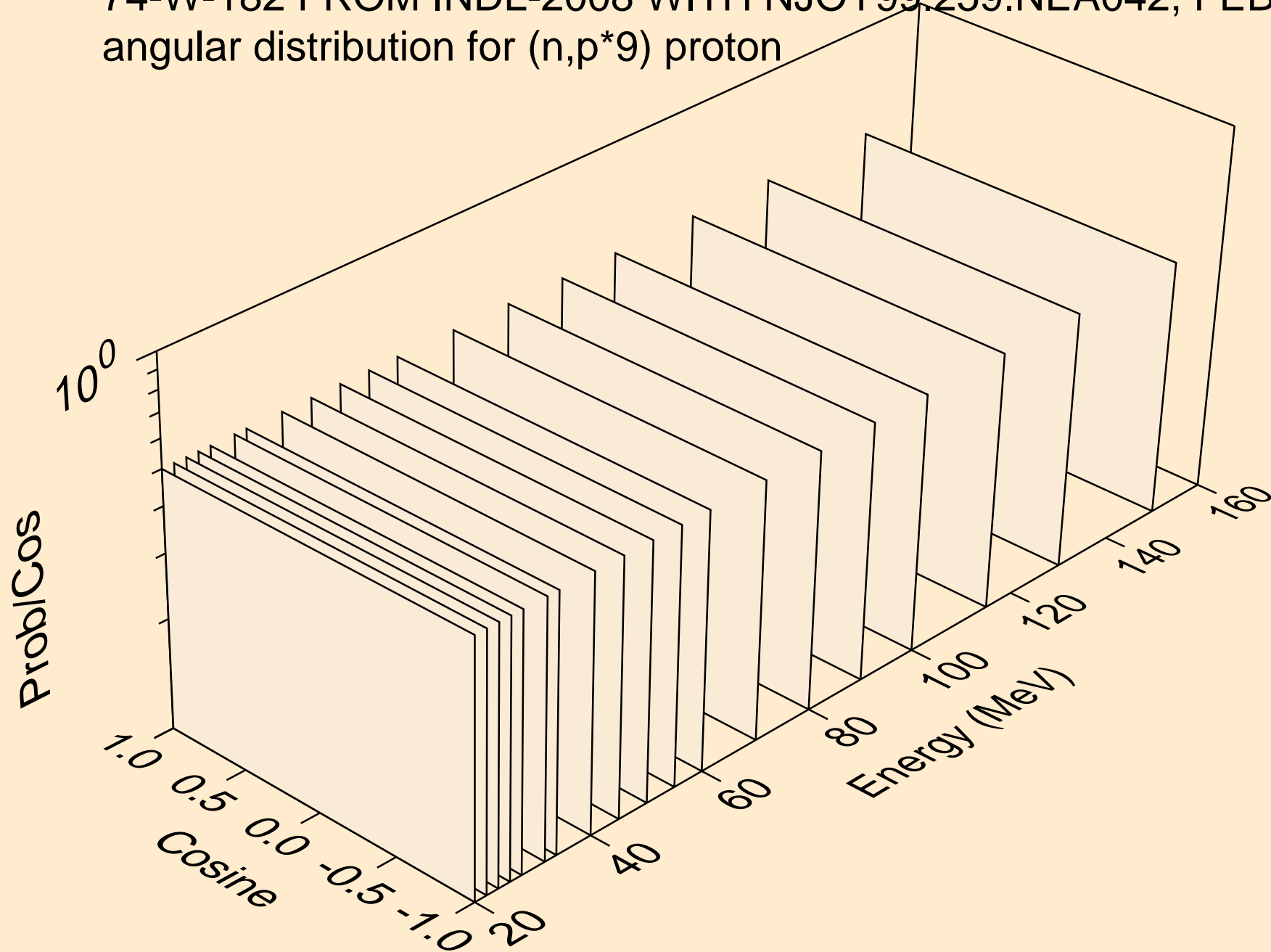

74-W-182 FROM INDL-2008 WITH NJOY99.259.NEA042, FEB. 200
angular distribution for (n,p*10) proton

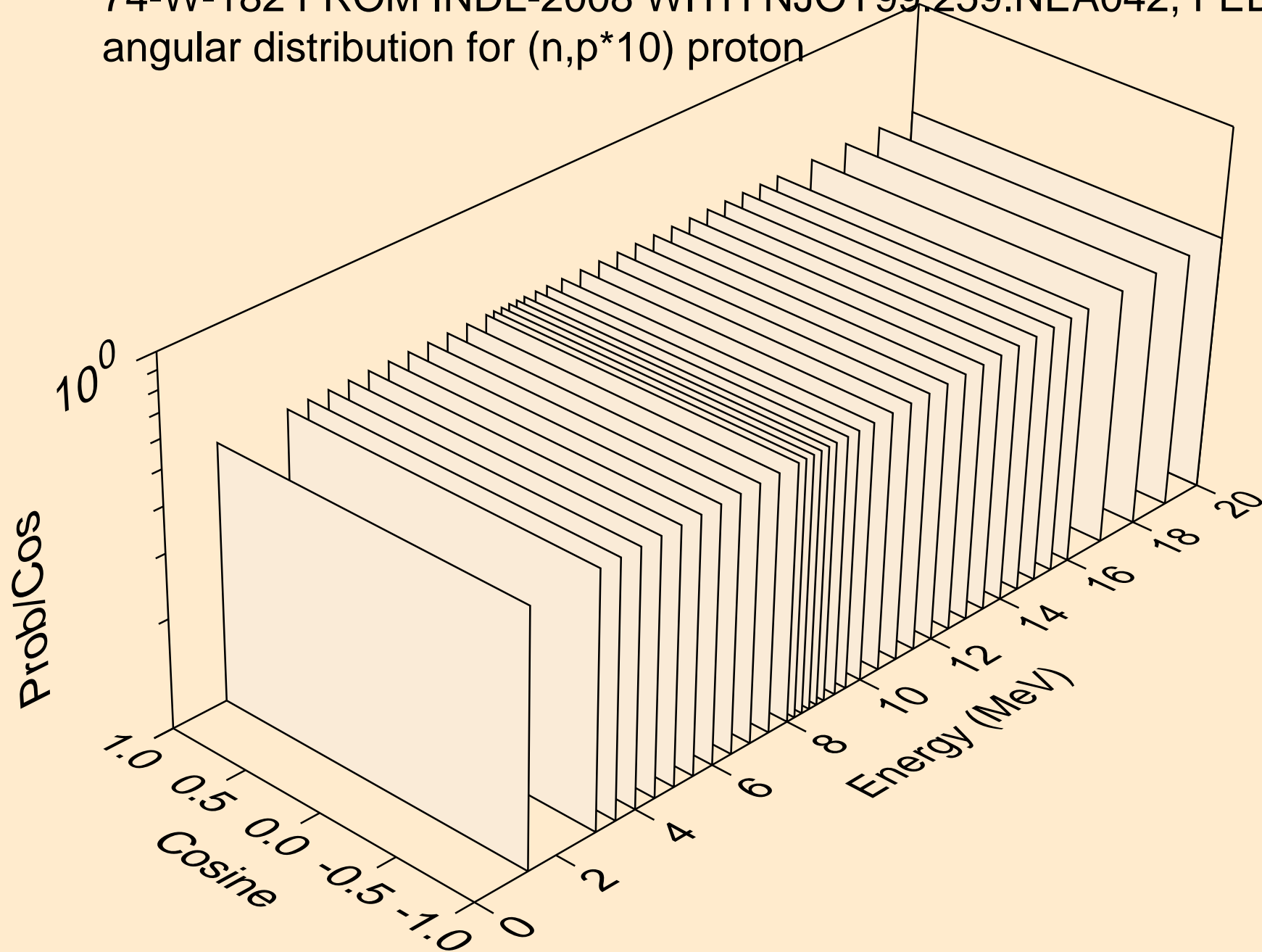

74-W-182 FROM INDL-2008 WITH NJOY99.259.NEA042, FEB. 200
angular distribution for (n,p*10) proton

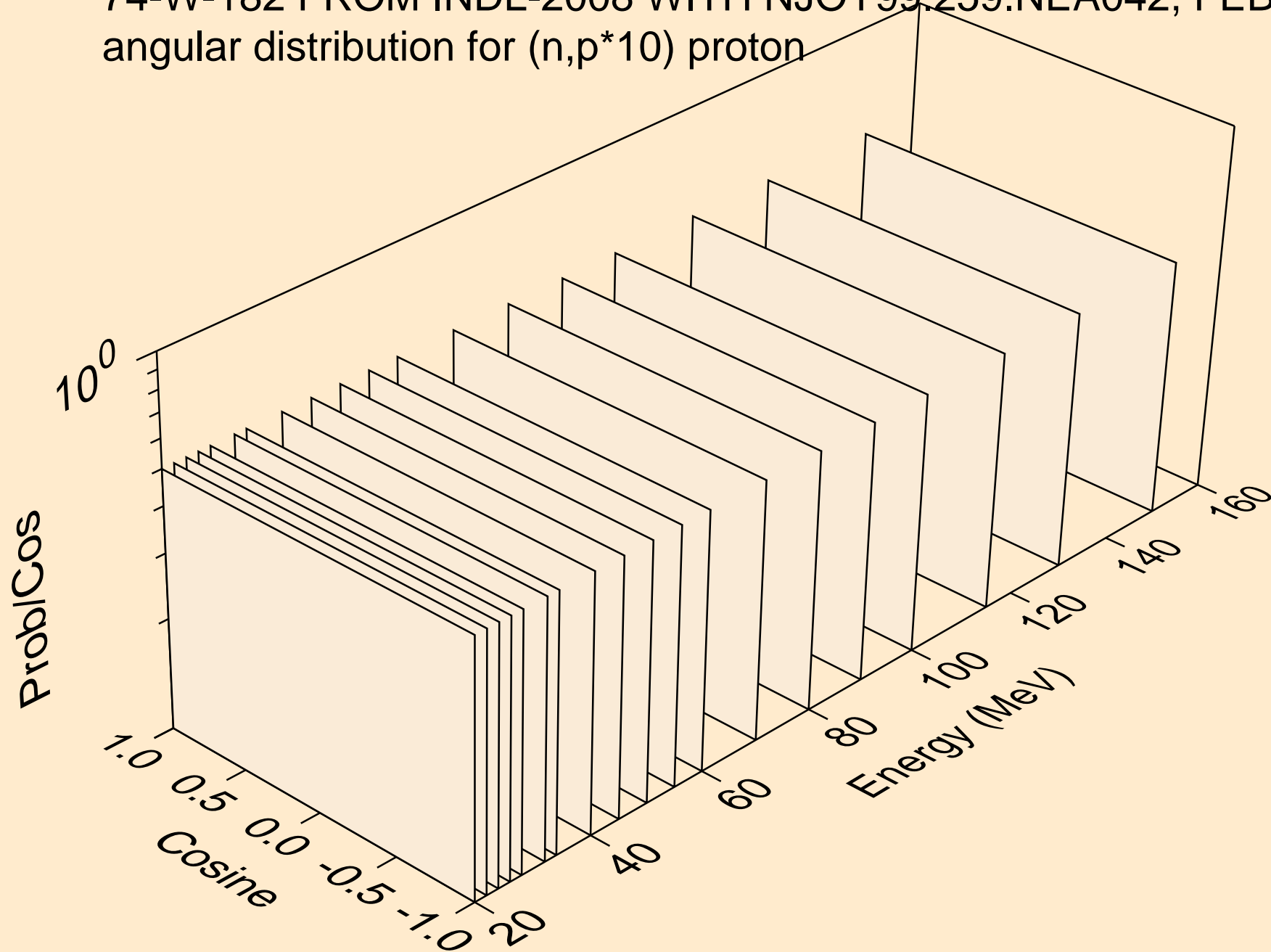

74-W-182 FROM INDL-2008 WITH NJOY99.259.NEA042, FEB. 200
angular distribution for (n,p*11) proton

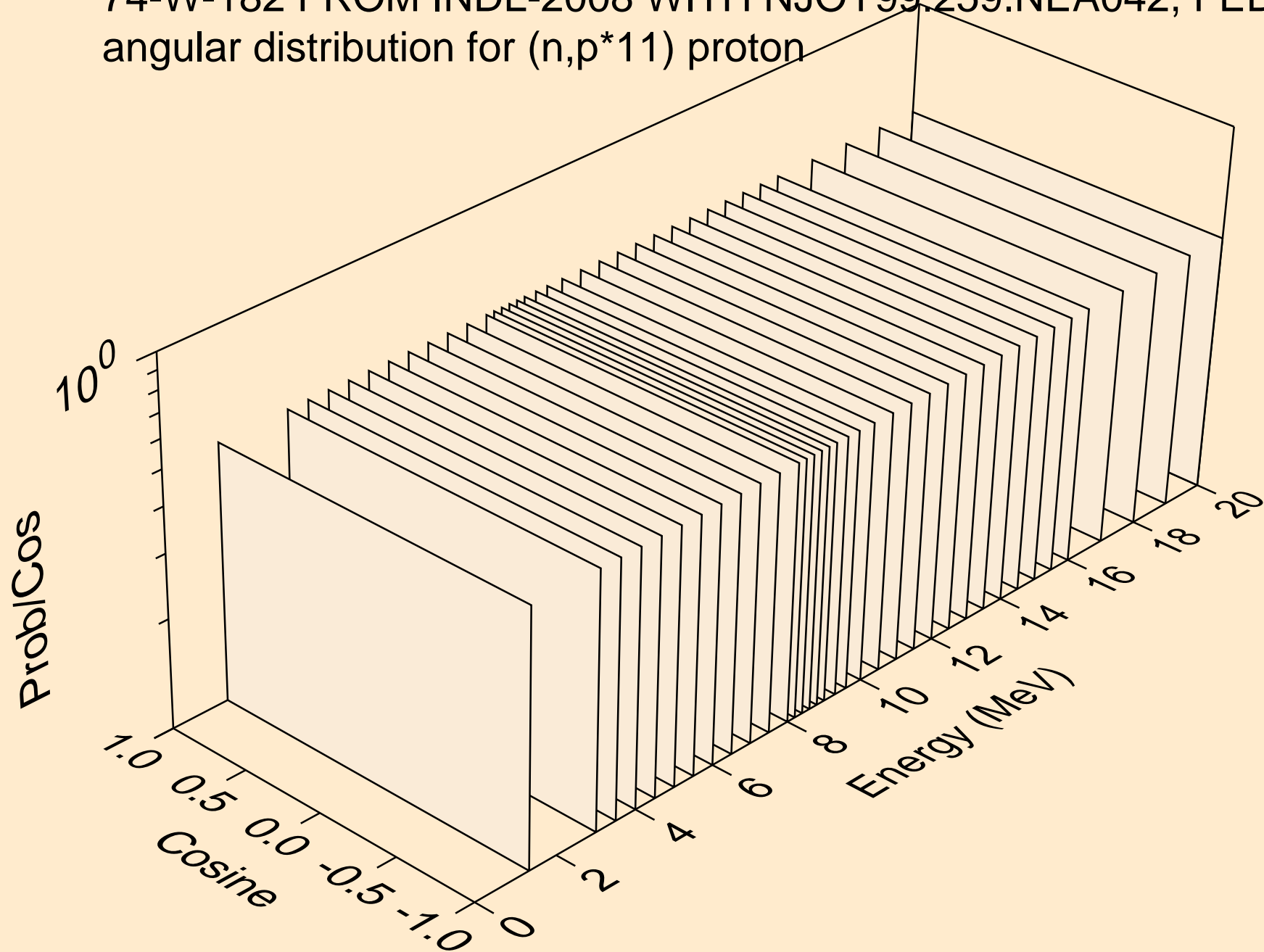

74-W-182 FROM INDL-2008 WITH NJOY99.259.NEA042, FEB. 200
angular distribution for (n,p*11) proton

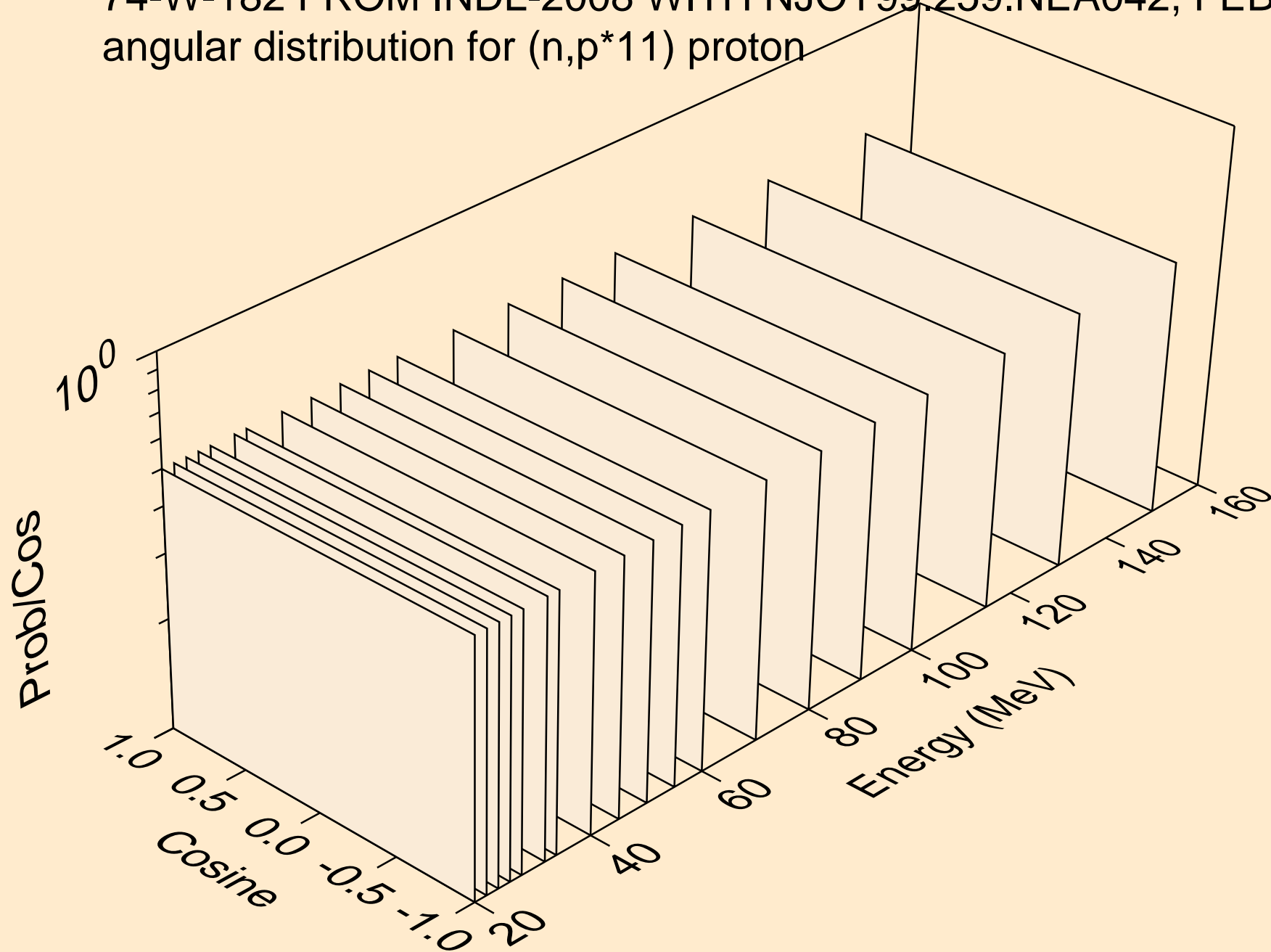

74-W-182 FROM INDL-2008 WITH NJOY99.259.NEA042, FEB. 200
angular distribution for (n,p*12) proton

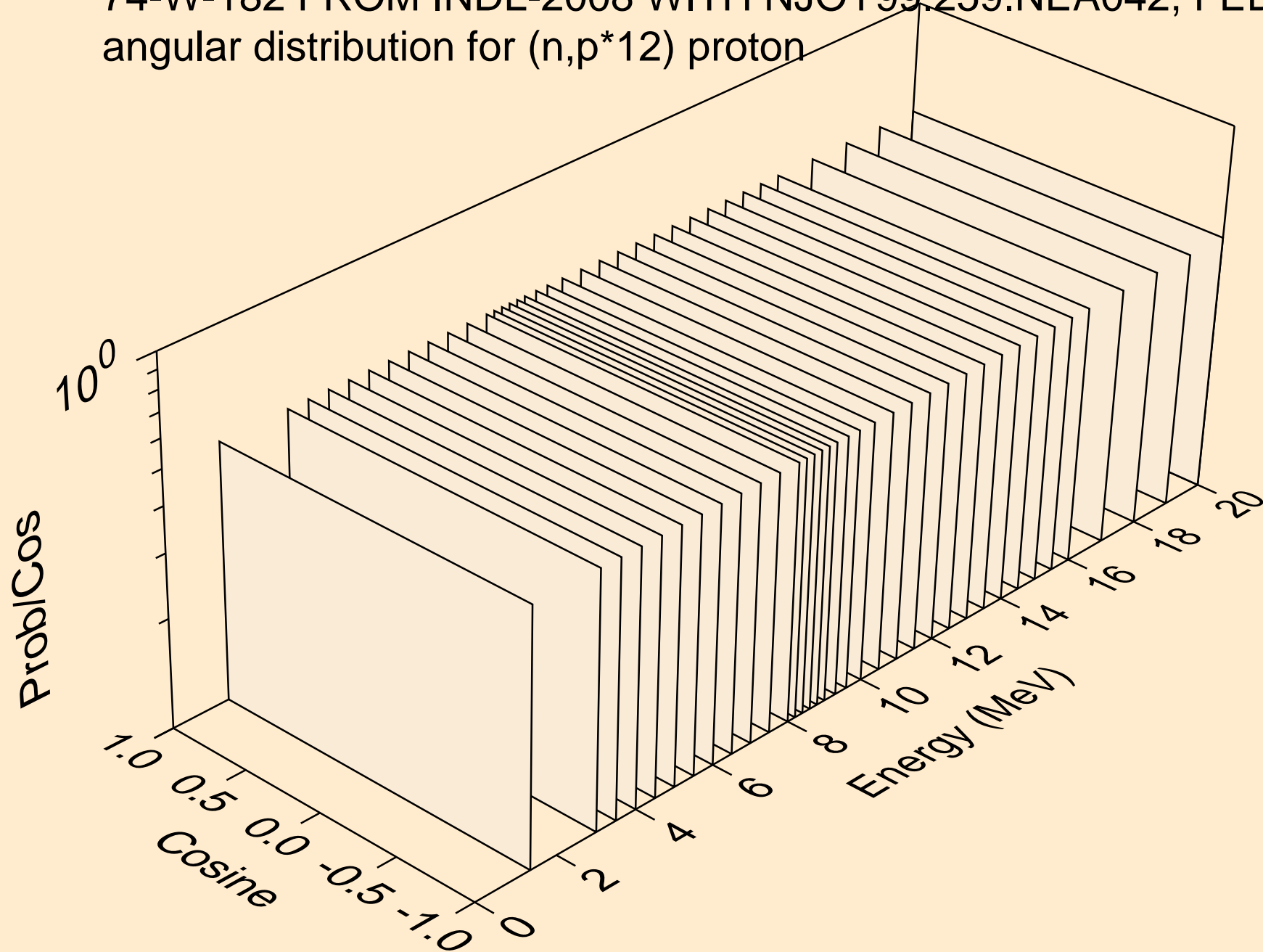

74-W-182 FROM INDL-2008 WITH NJOY99.259.NEA042, FEB. 200
angular distribution for (n,p*12) proton

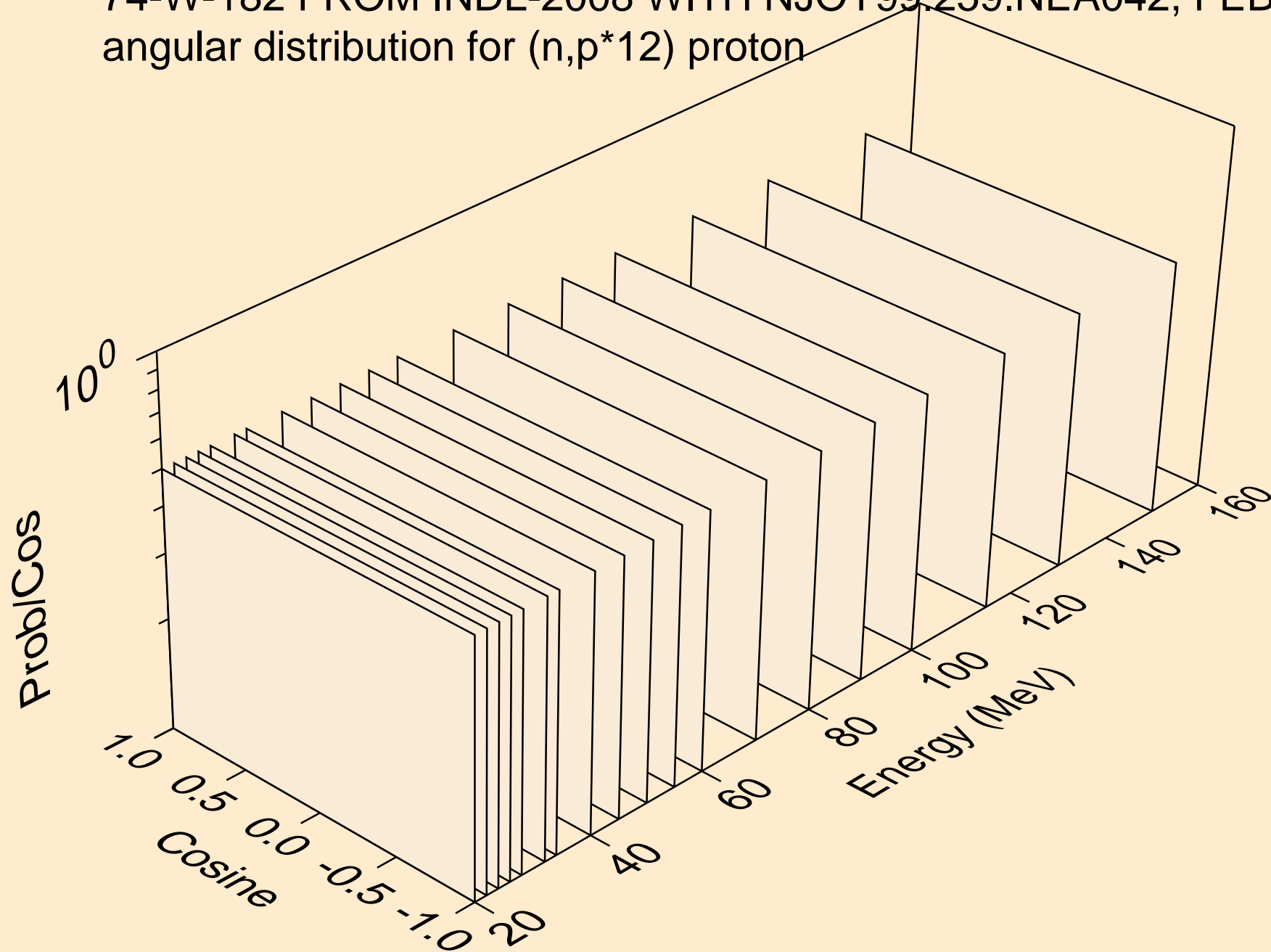

74-W-182 FROM INDL-2008 WITH NJOY99.259.NEA042, FEB. 200
angular distribution for (n,p*13) proton

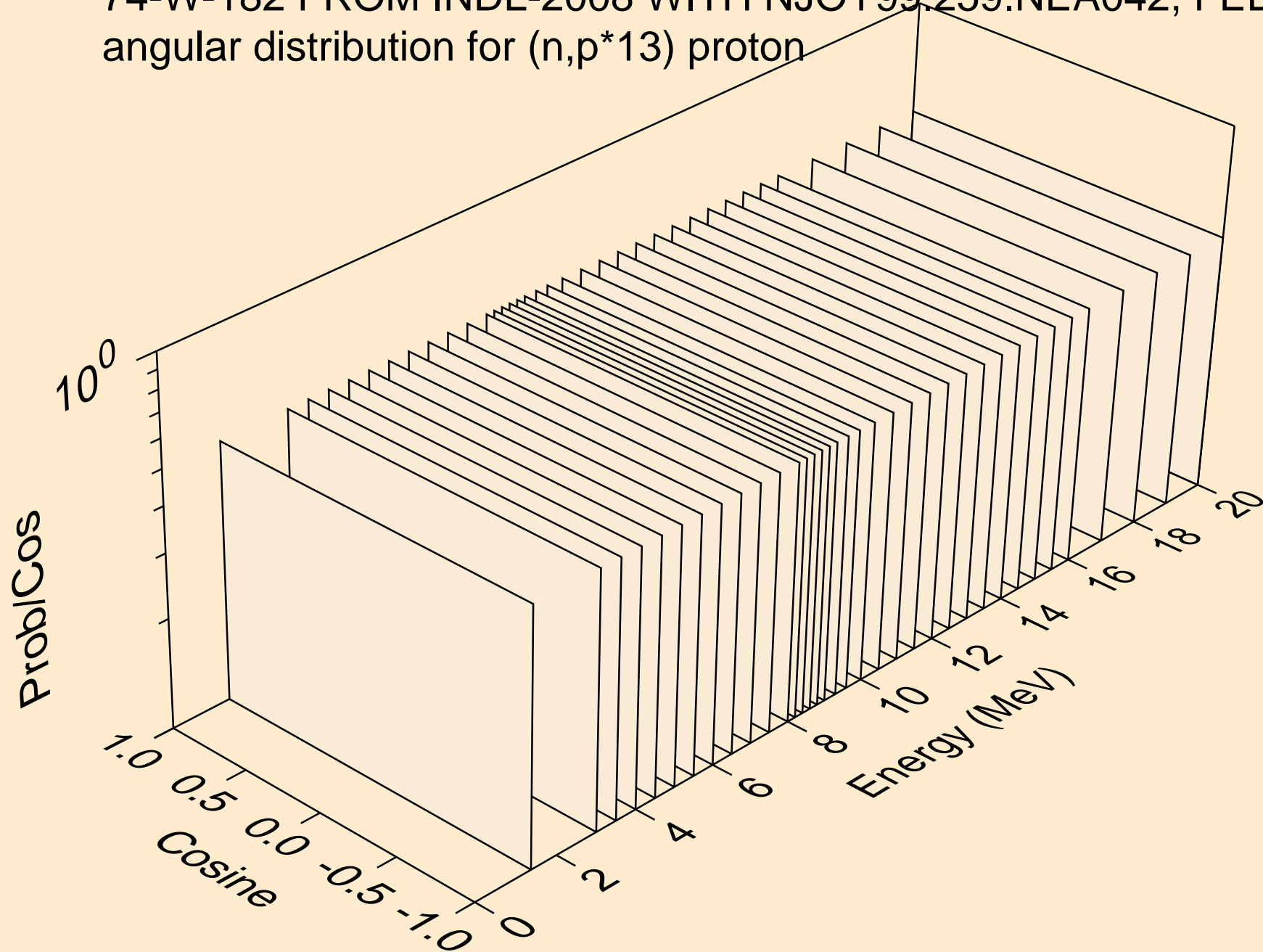

74-W-182 FROM INDL-2008 WITH NJOY99.259.NEA042, FEB. 200
angular distribution for (n,p*13) proton

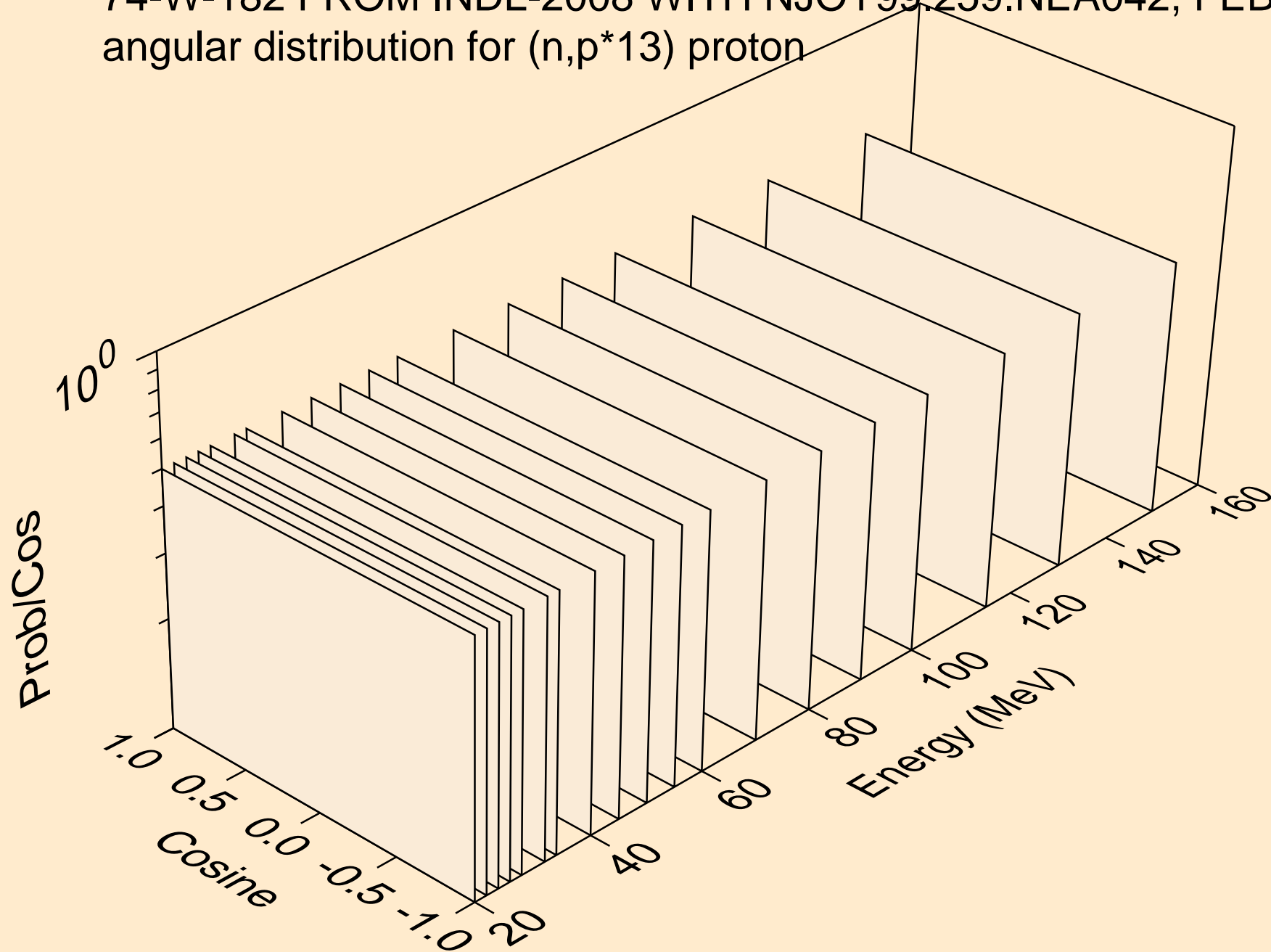

74-W-182 FROM INDL-2008 WITH NJOY99.259.NEA042, FEB. 200
angular distribution for (n,p*14) proton

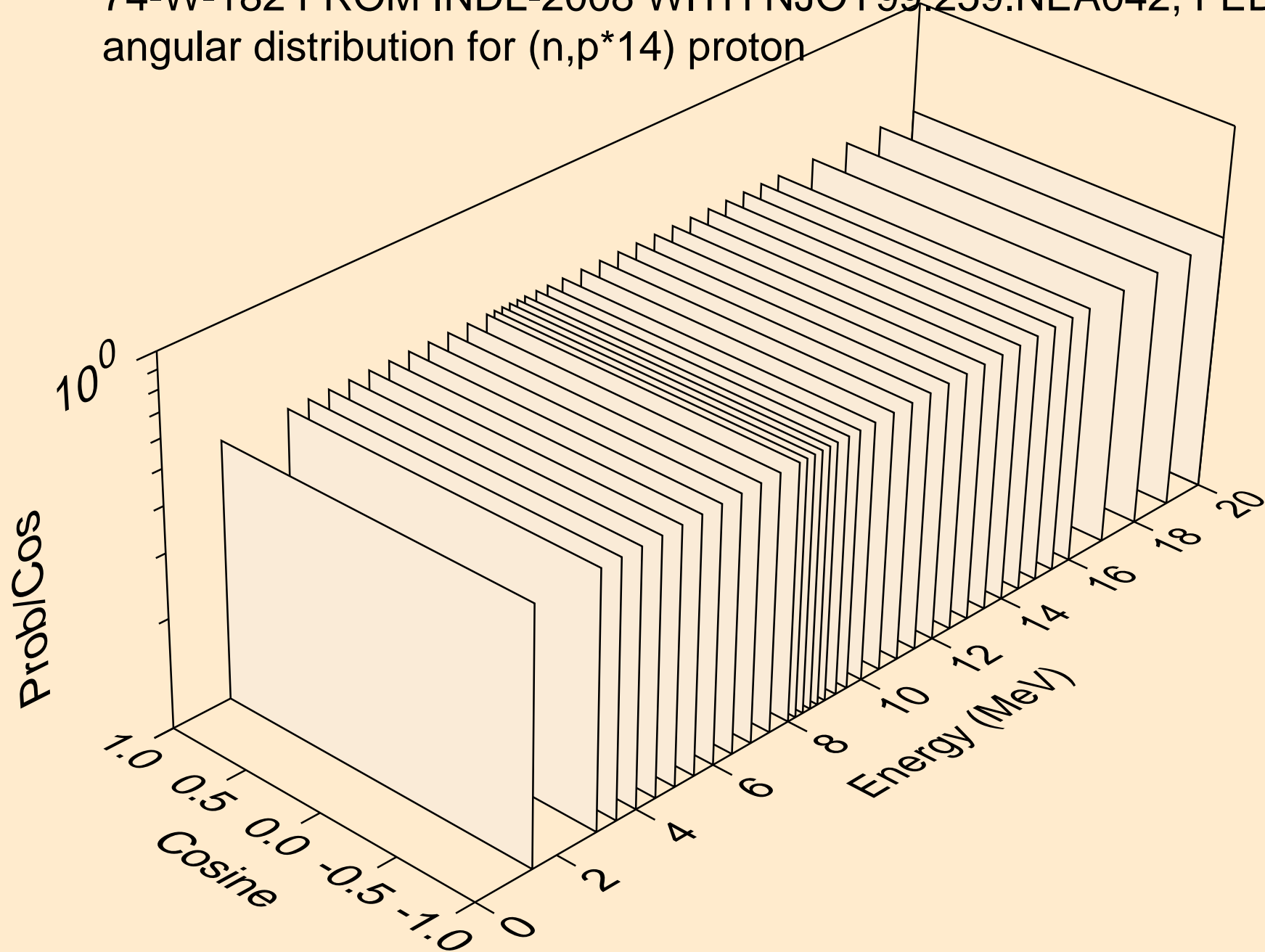

74-W-182 FROM INDL-2008 WITH NJOY99.259.NEA042, FEB. 200
angular distribution for (n,p*14) proton

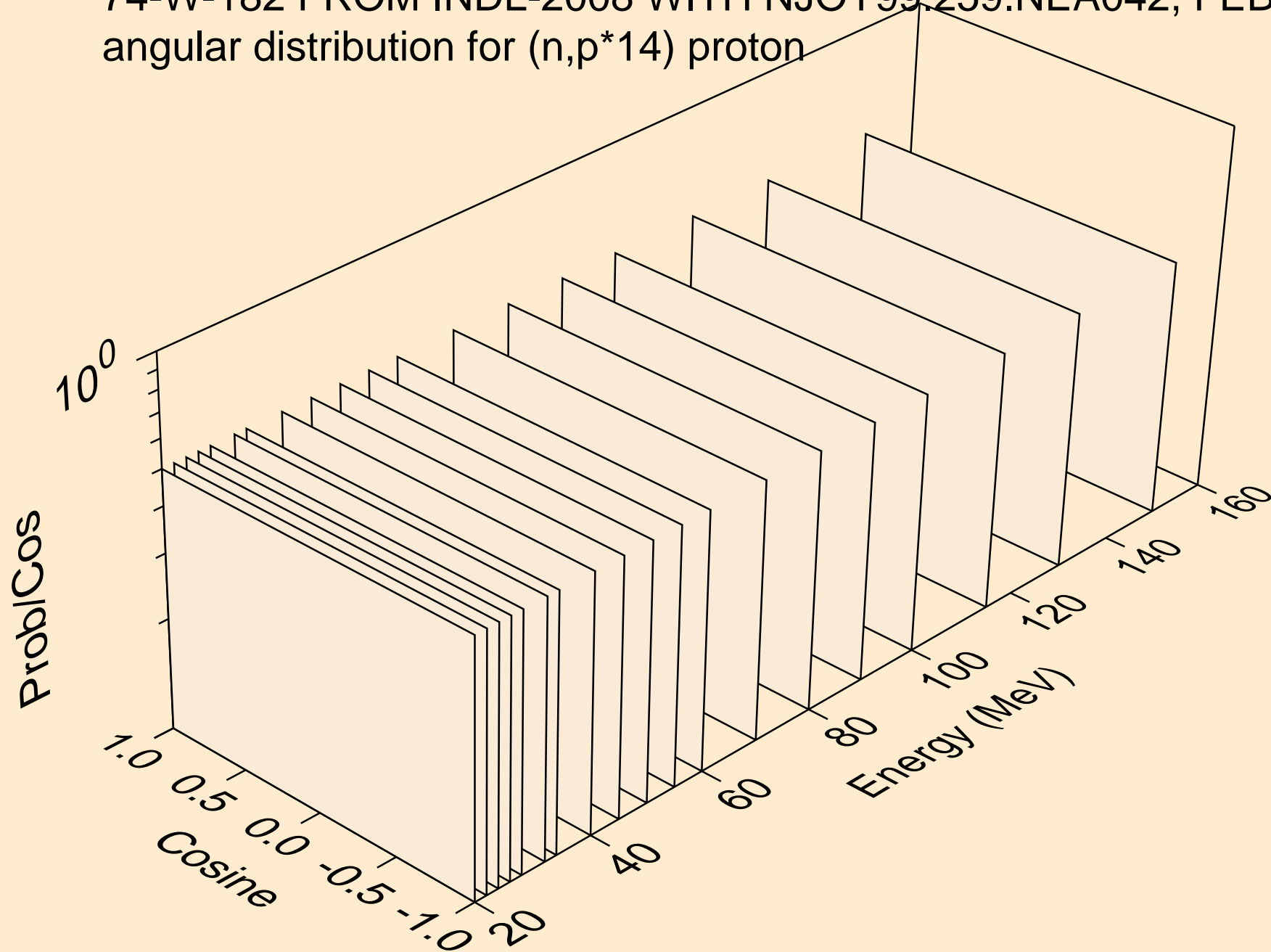

74-W-182 FROM INDL-2008 WITH NJOY99.259.NEA042, FEB. 200
angular distribution for (n,p*15) proton

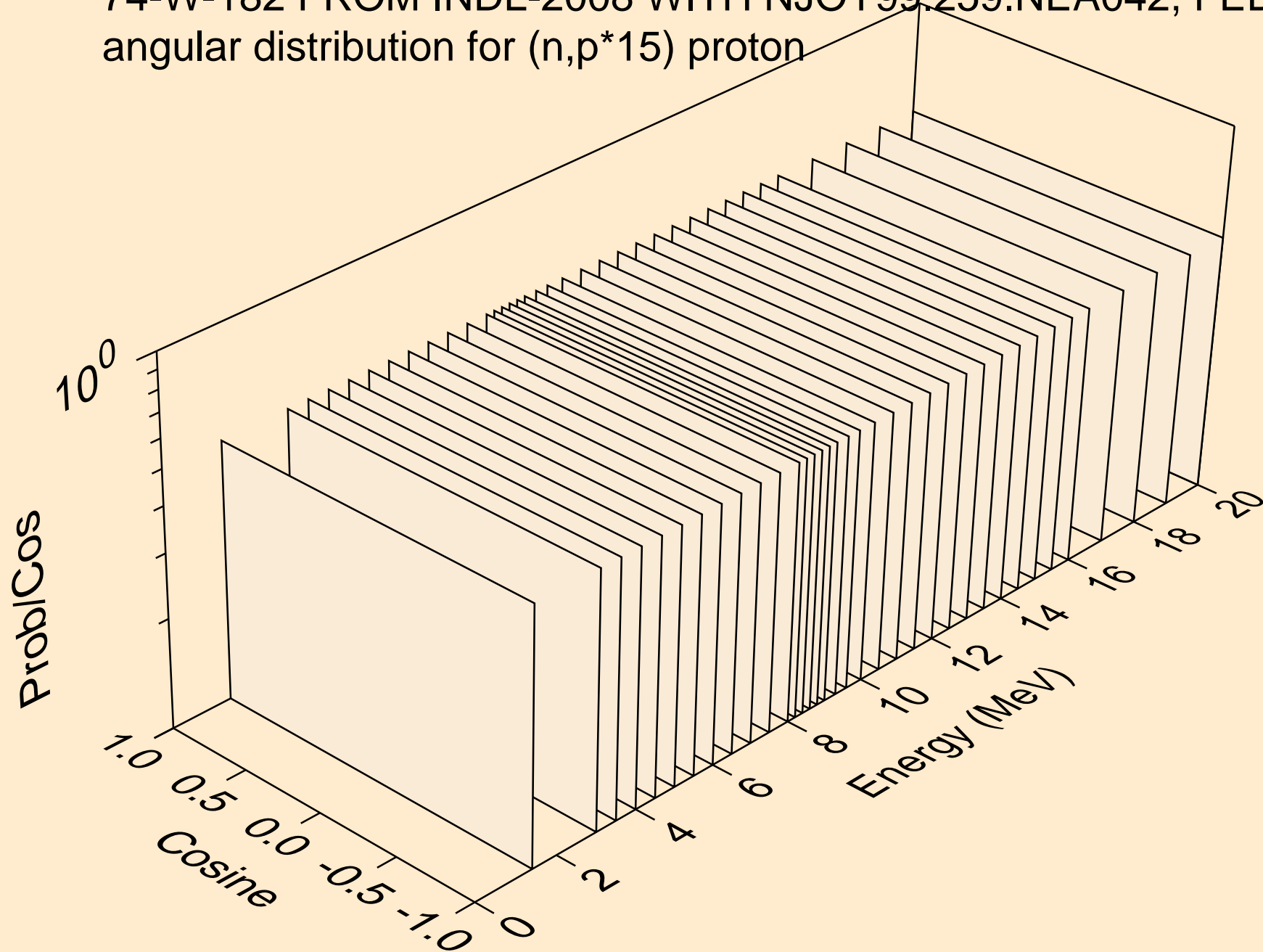

74-W-182 FROM INDL-2008 WITH NJOY99.259.NEA042, FEB. 200
angular distribution for (n,p*15) proton

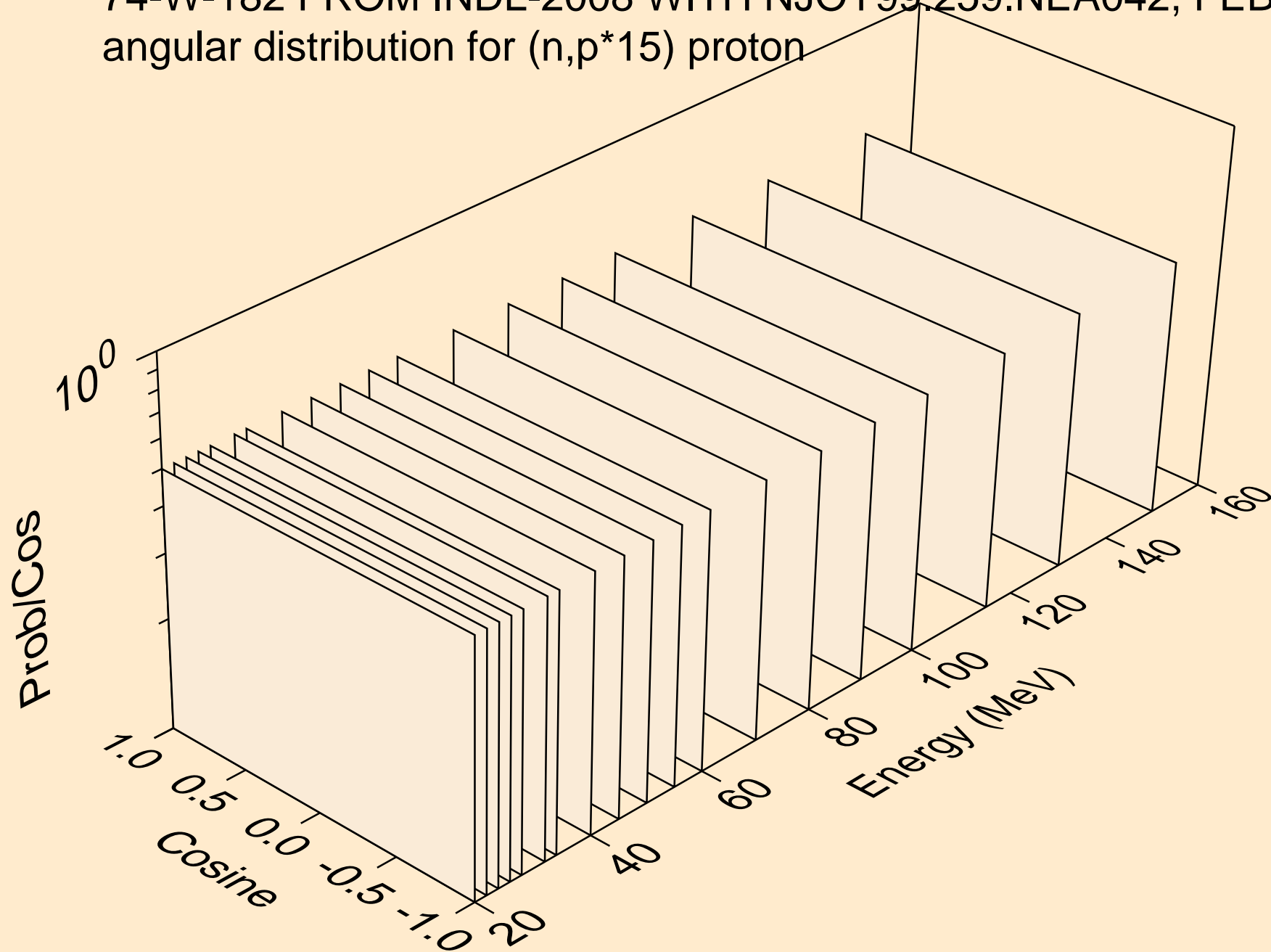

74-W-182 FROM INDL-2008 WITH NJOY99.259.NEA042, FEB. 200
angular distribution for (n,p*16) proton

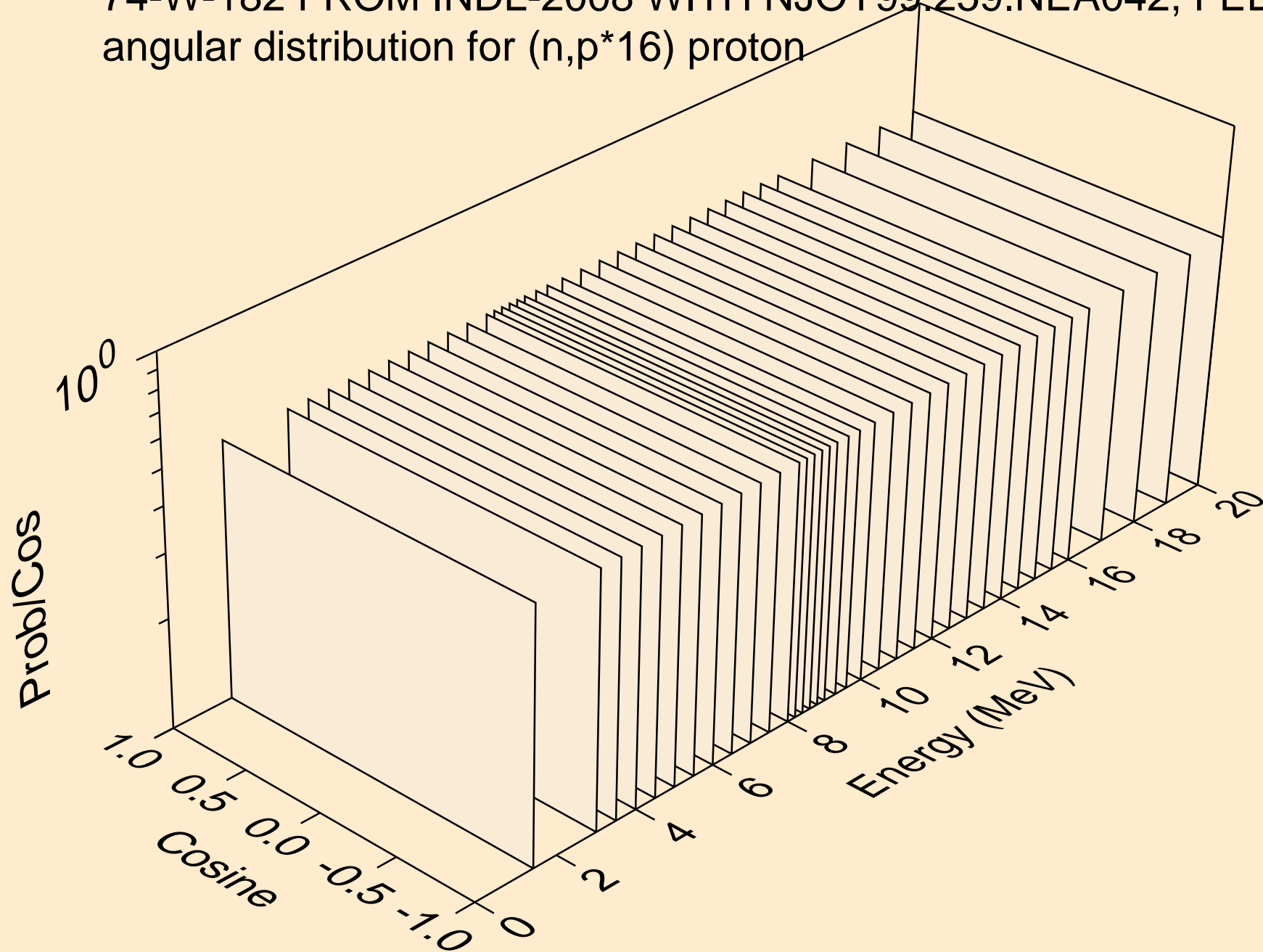

74-W-182 FROM INDL-2008 WITH NJOY99.259.NEA042, FEB. 200
angular distribution for (n,p*16) proton

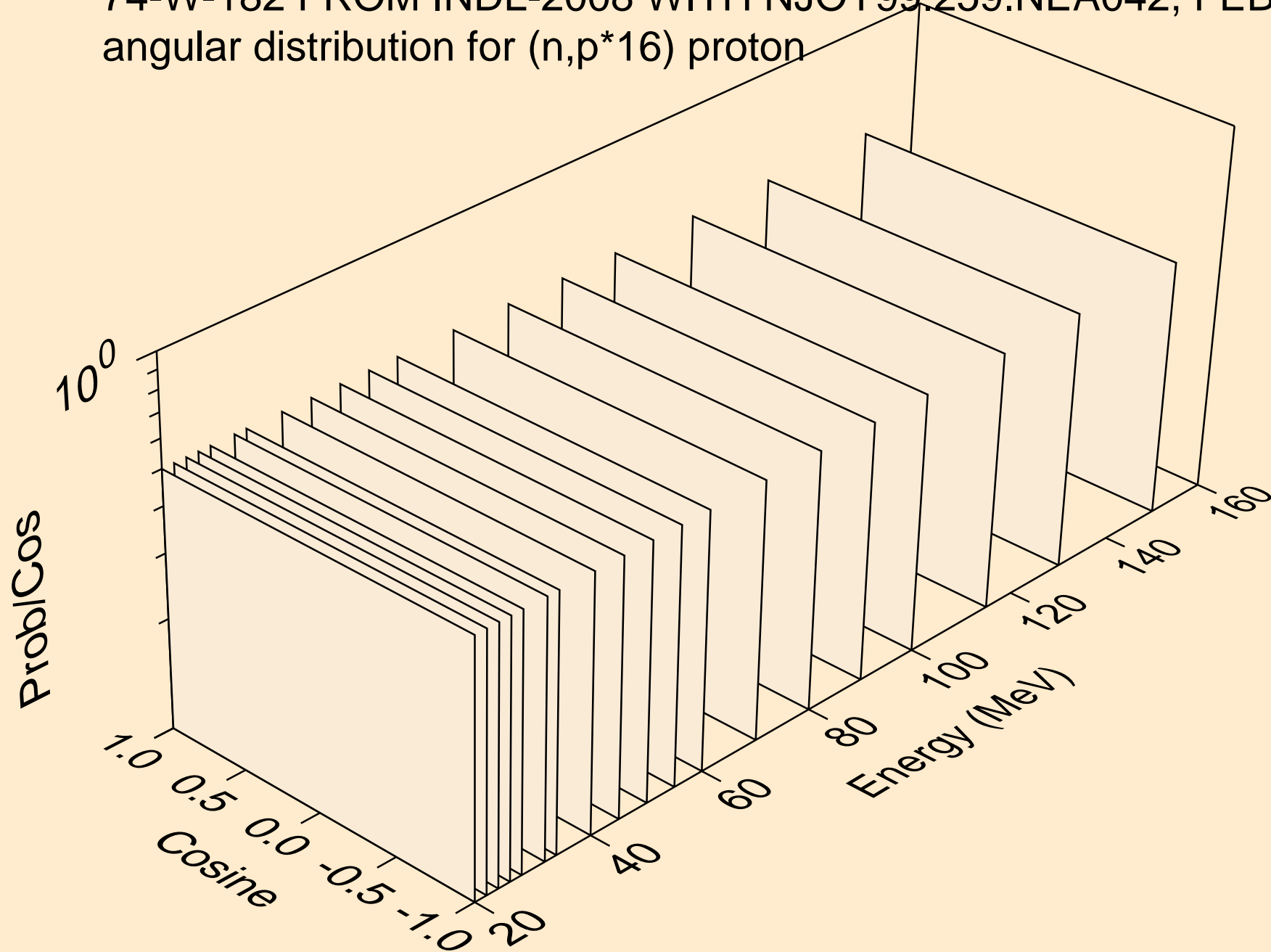

74-W-182 FROM INDL-2008 WITH NJOY99.259.NEA042, FEB. 200
angular distribution for (n,p*17) proton

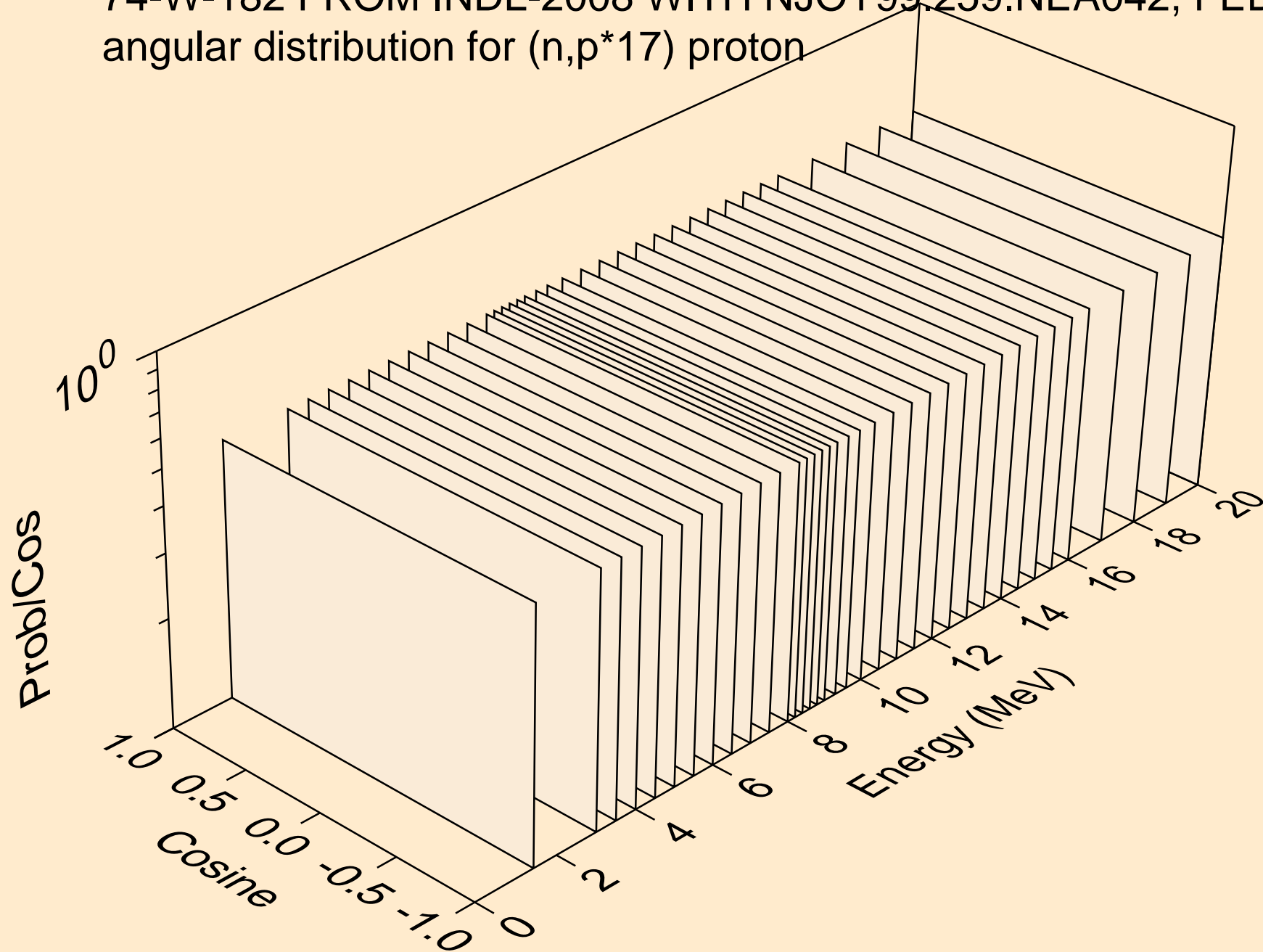

74-W-182 FROM INDL-2008 WITH NJOY99.259.NEA042, FEB. 200
angular distribution for (n,p*17) proton

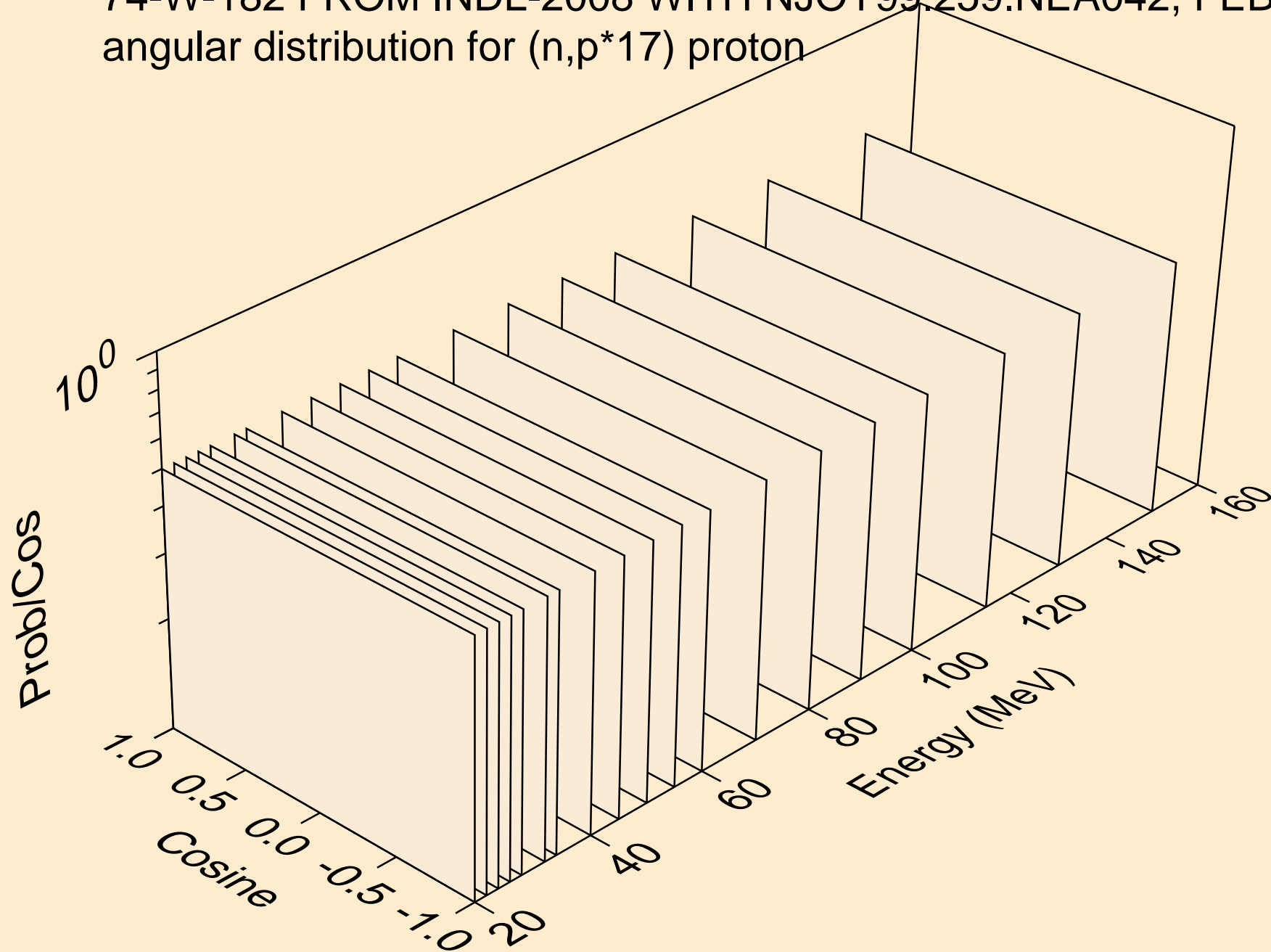

74-W-182 FROM INDL-2008 WITH NJOY99.259.NEA042, FEB. 200
angular distribution for (n,p*18) proton

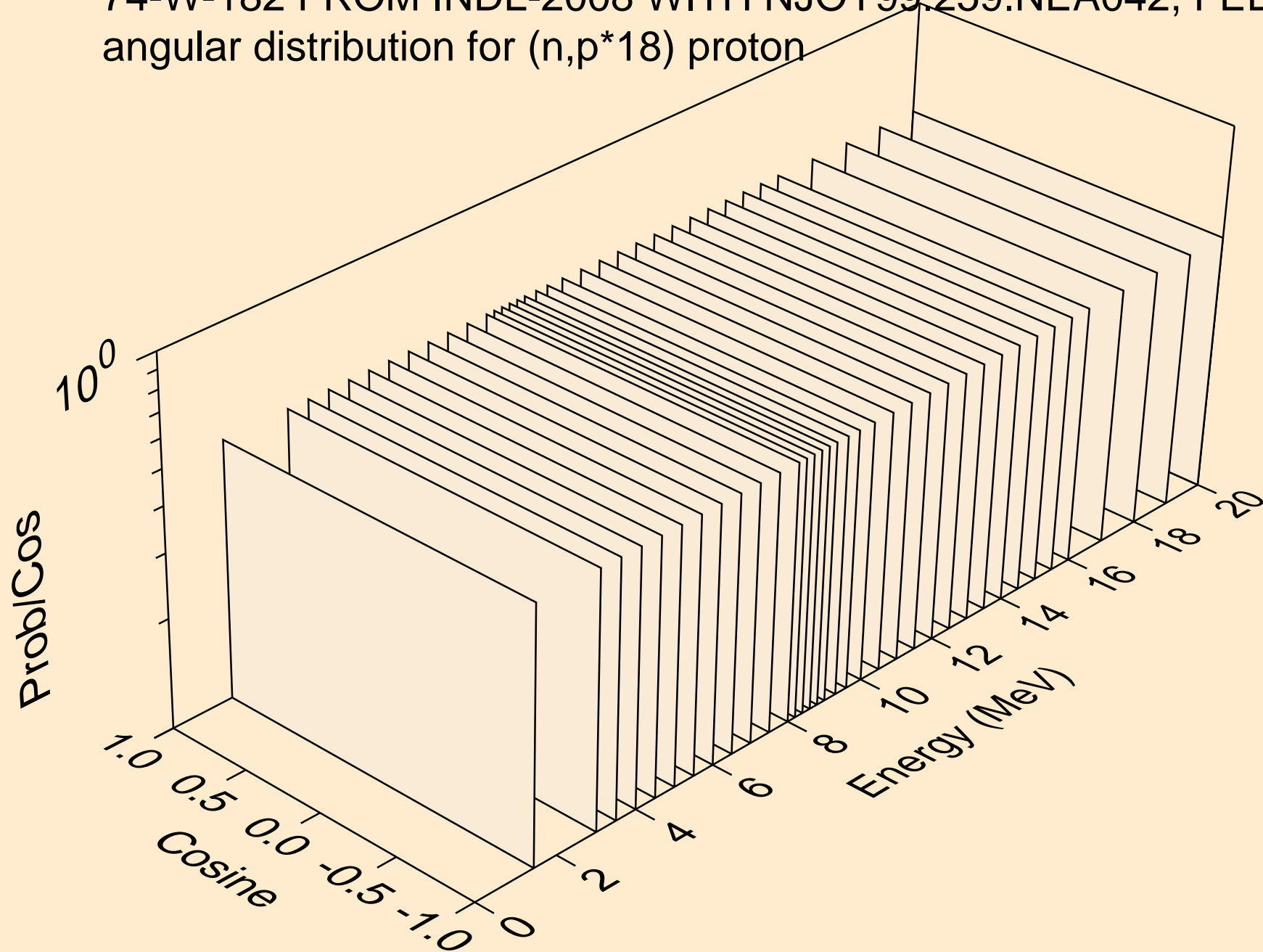

74-W-182 FROM INDL-2008 WITH NJOY99.259.NEA042, FEB. 200
angular distribution for (n,p*18) proton

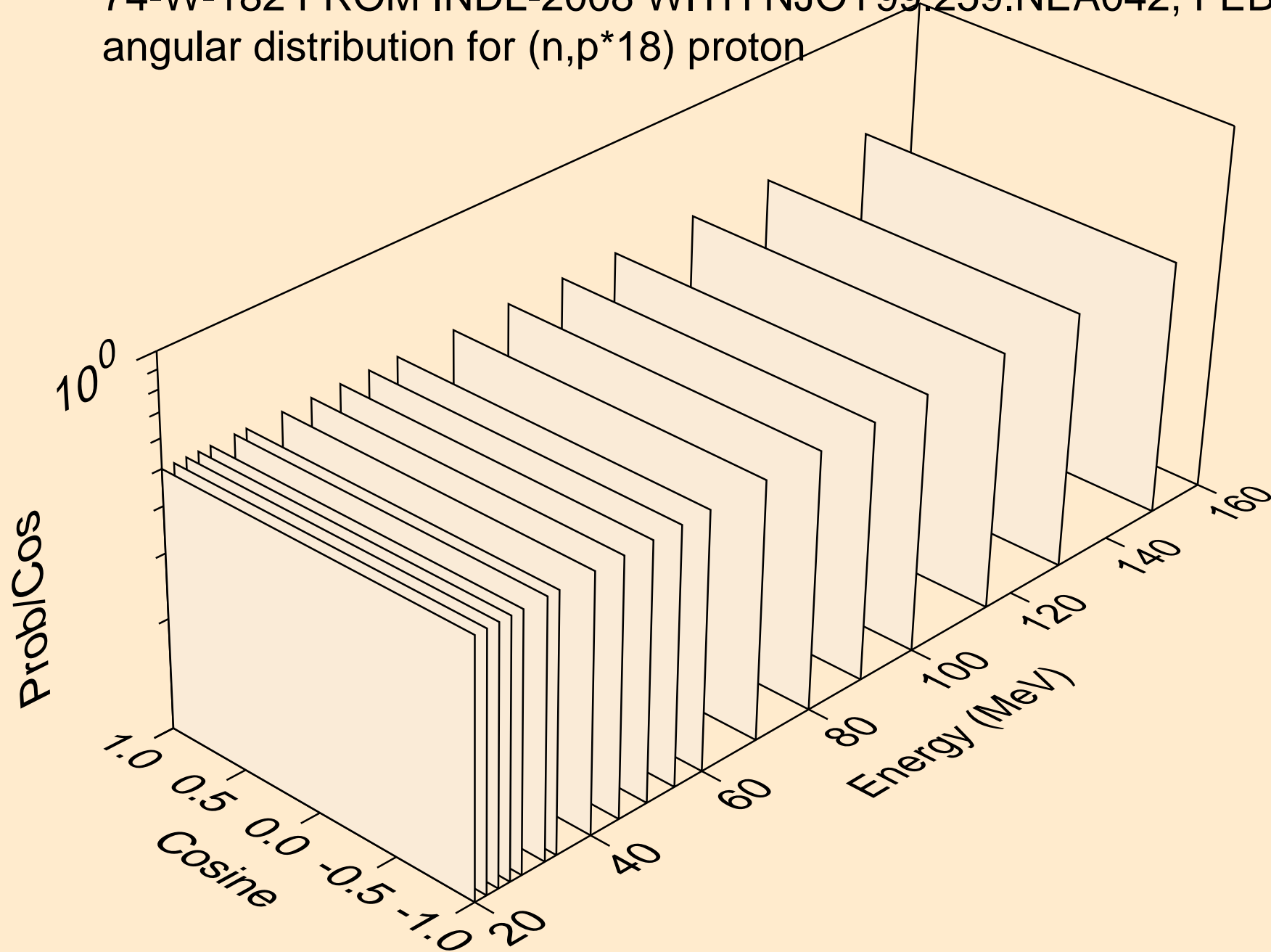

74-W-182 FROM INDL-2008 WITH NJOY99.259.NEA042, FEB. 200
angular distribution for (n,p*19) proton

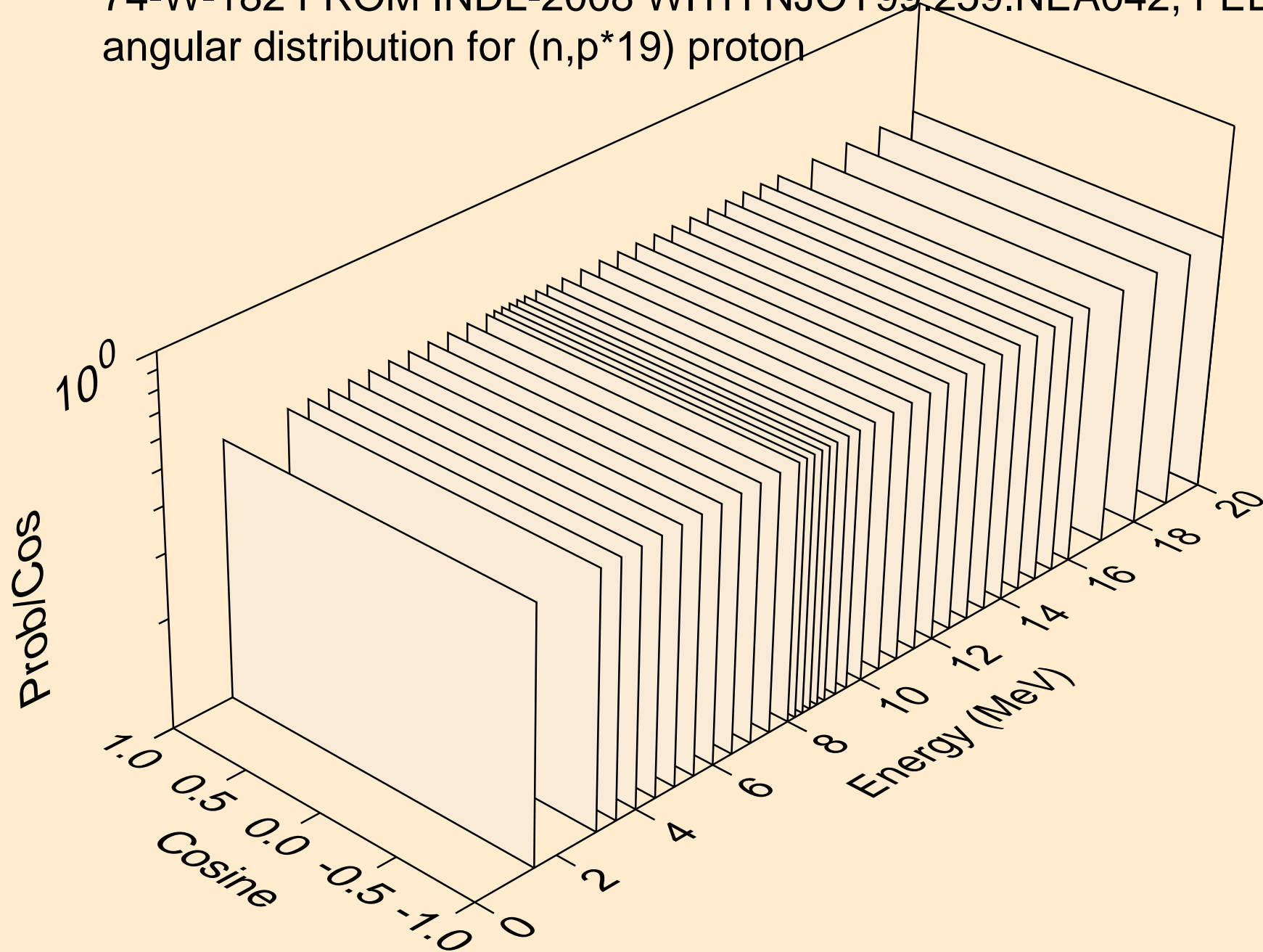

74-W-182 FROM INDL-2008 WITH NJOY99.259.NEA042, FEB. 200
angular distribution for (n,p*19) proton

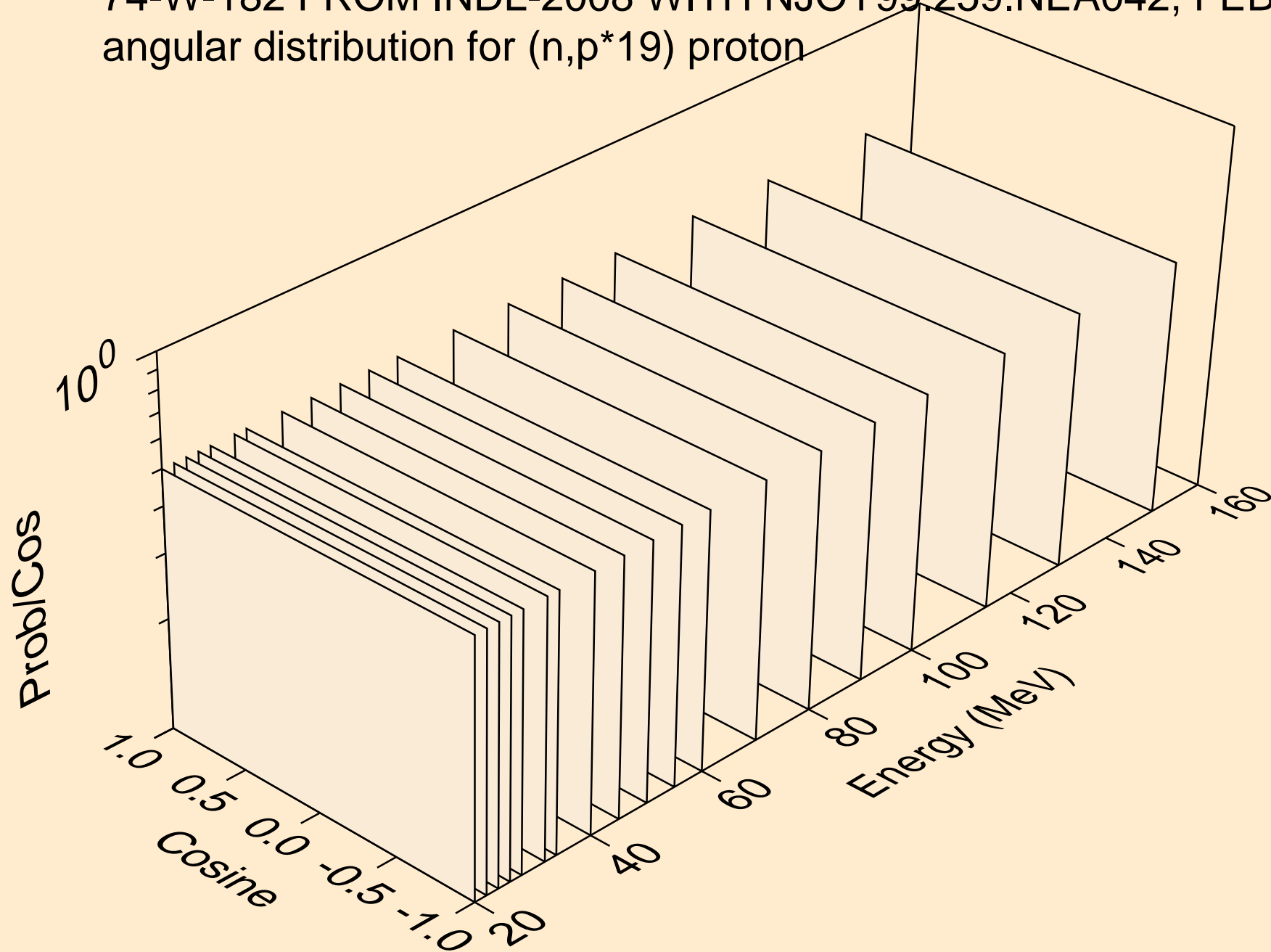

74-W-182 FROM INDL-2008 WITH NJOY99.259.NEA042, FEB. 200
angular distribution for (n,p*20) proton

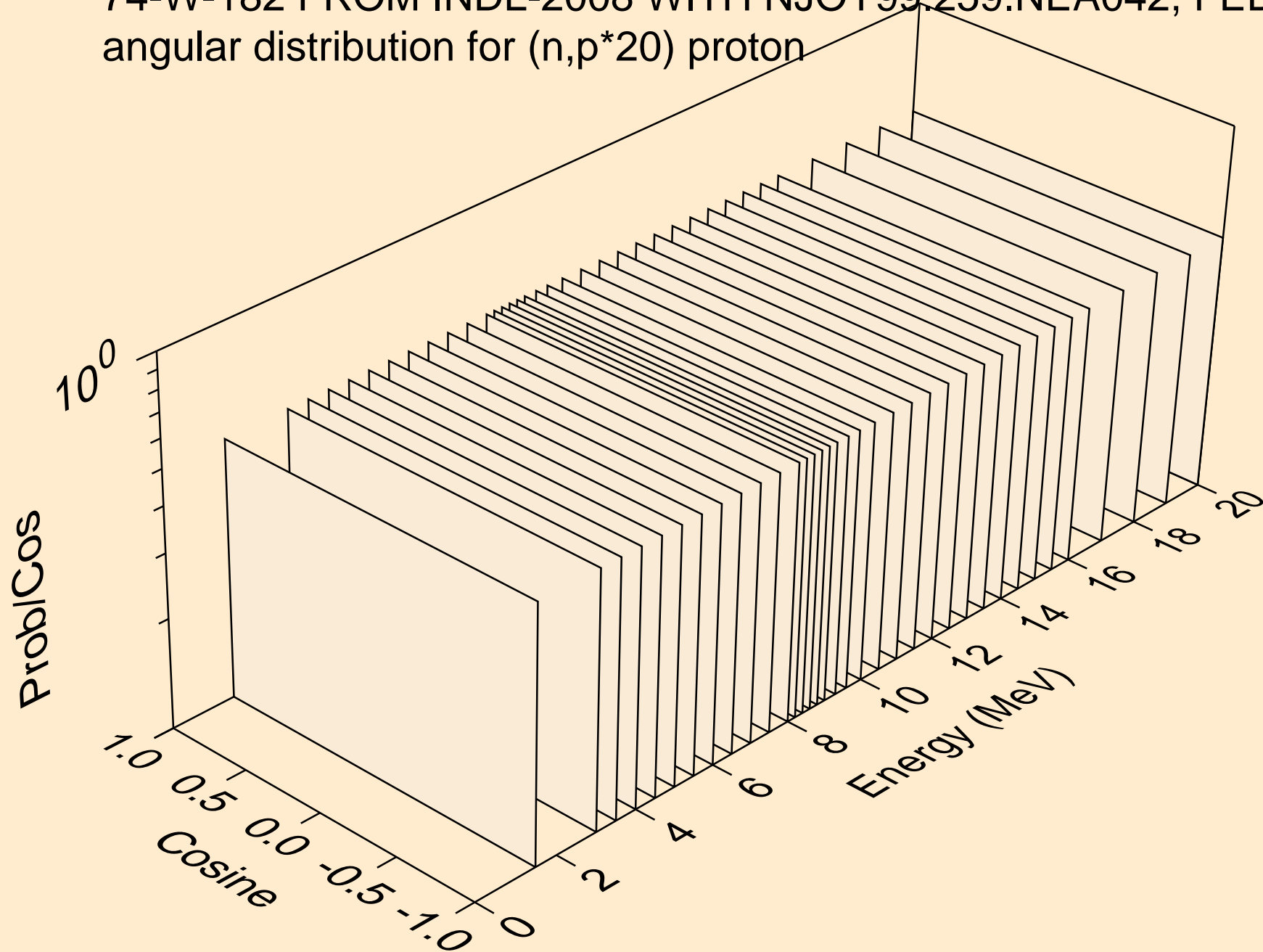

74-W-182 FROM INDL-2008 WITH NJOY99.259.NEA042, FEB. 200
angular distribution for (n,p*20) proton

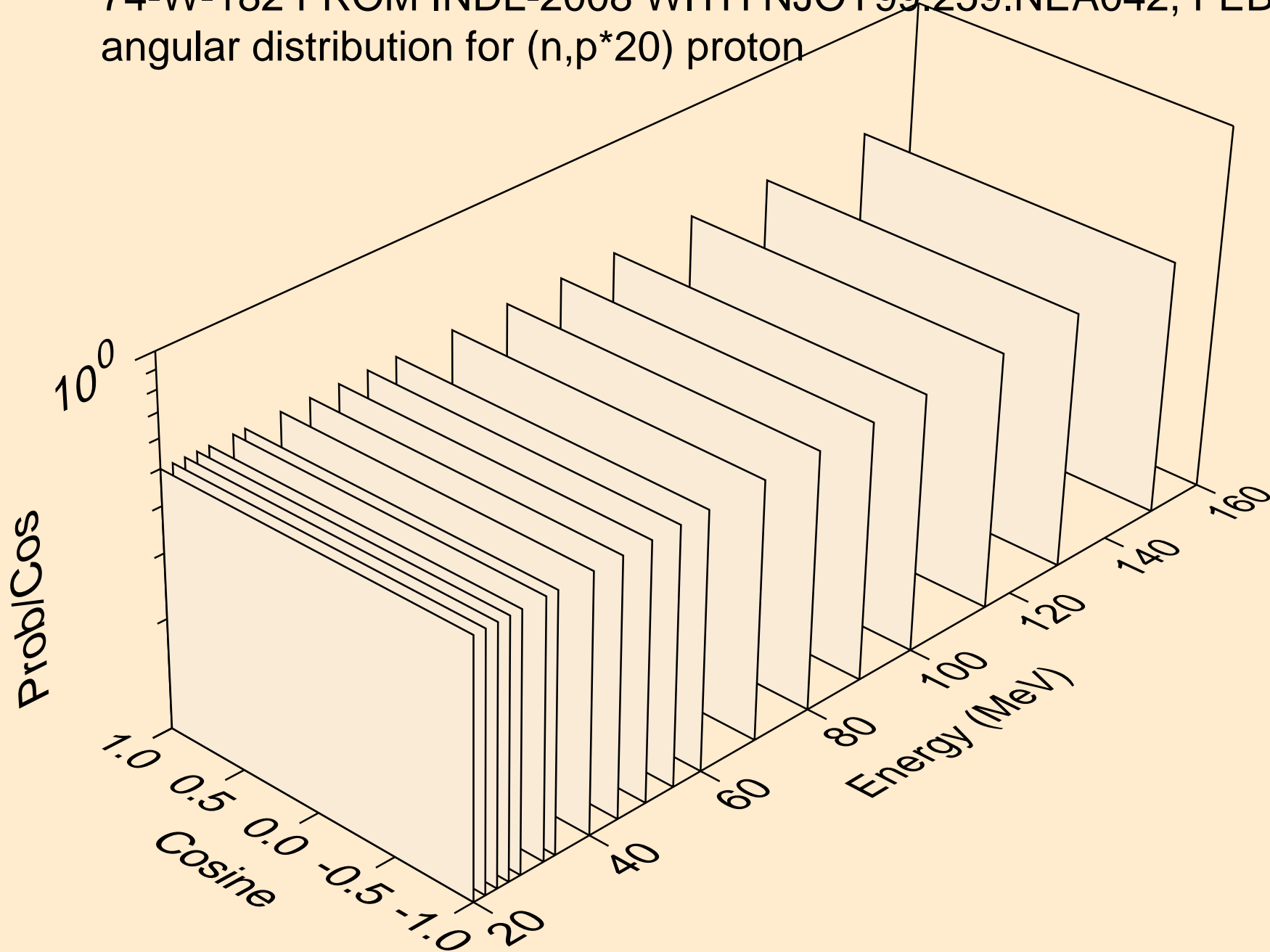

74-W-182 FROM INDL-2008 WITH NJOY99.259.NEA042, FEB. 200
angular distribution for (n,p*21) proton

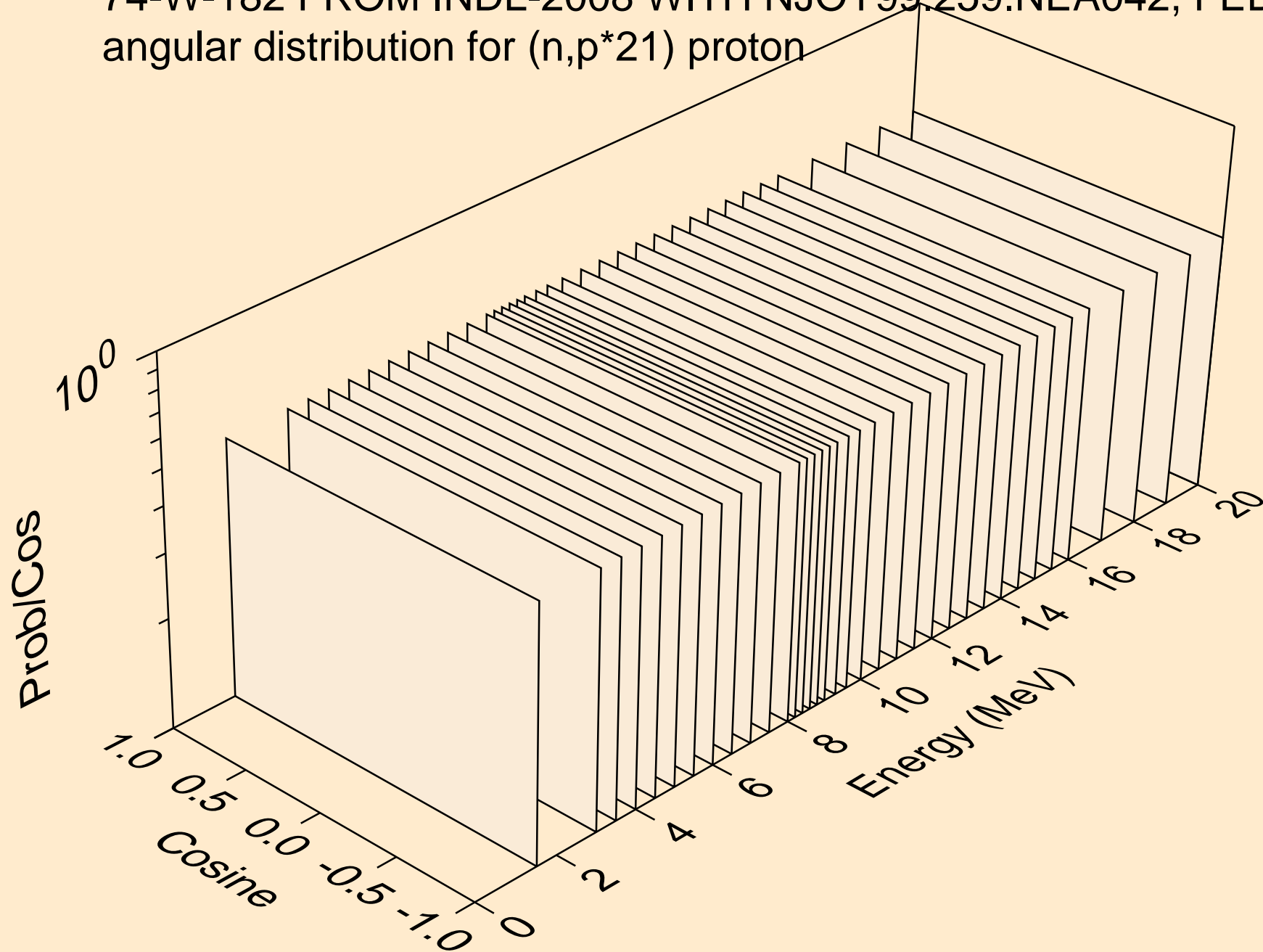

74-W-182 FROM INDL-2008 WITH NJOY99.259.NEA042, FEB. 200
angular distribution for (n,p*21) proton

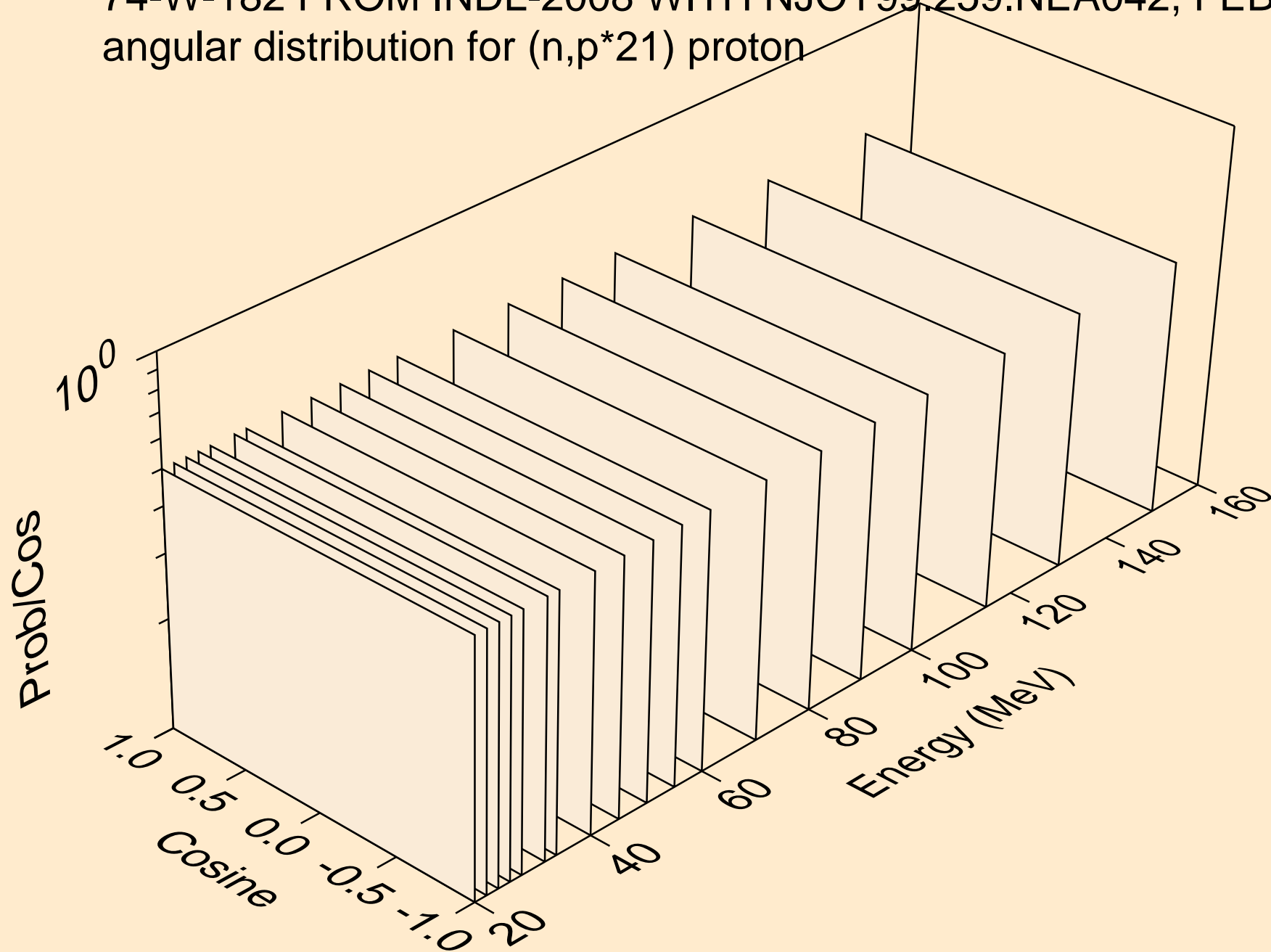

74-W-182 FROM INDL-2008 WITH NJOY99.259.NEA042, FEB. 200
angular distribution for (n,p*22) proton

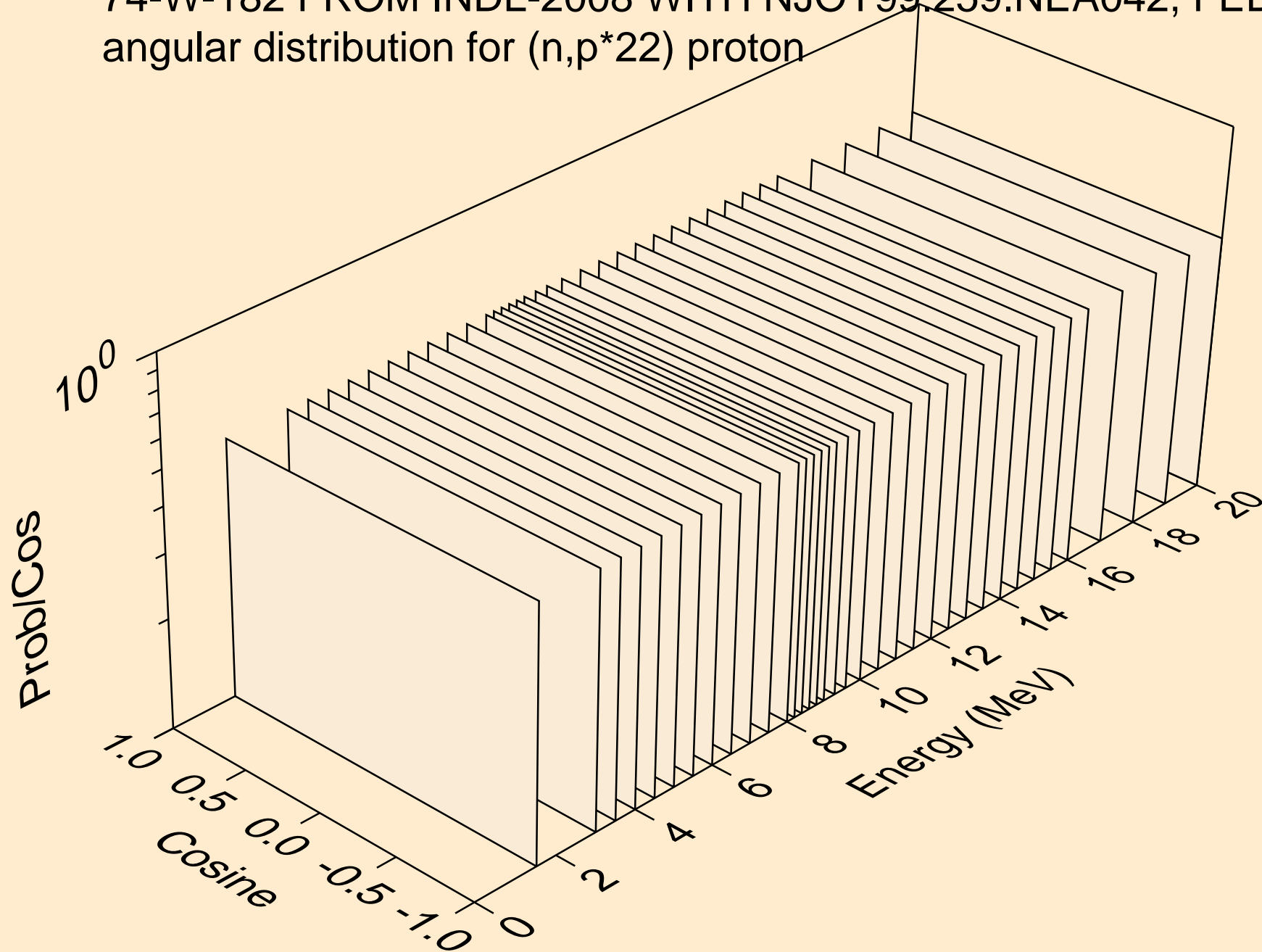

74-W-182 FROM INDL-2008 WITH NJOY99.259.NEA042, FEB. 200
angular distribution for (n,p*22) proton

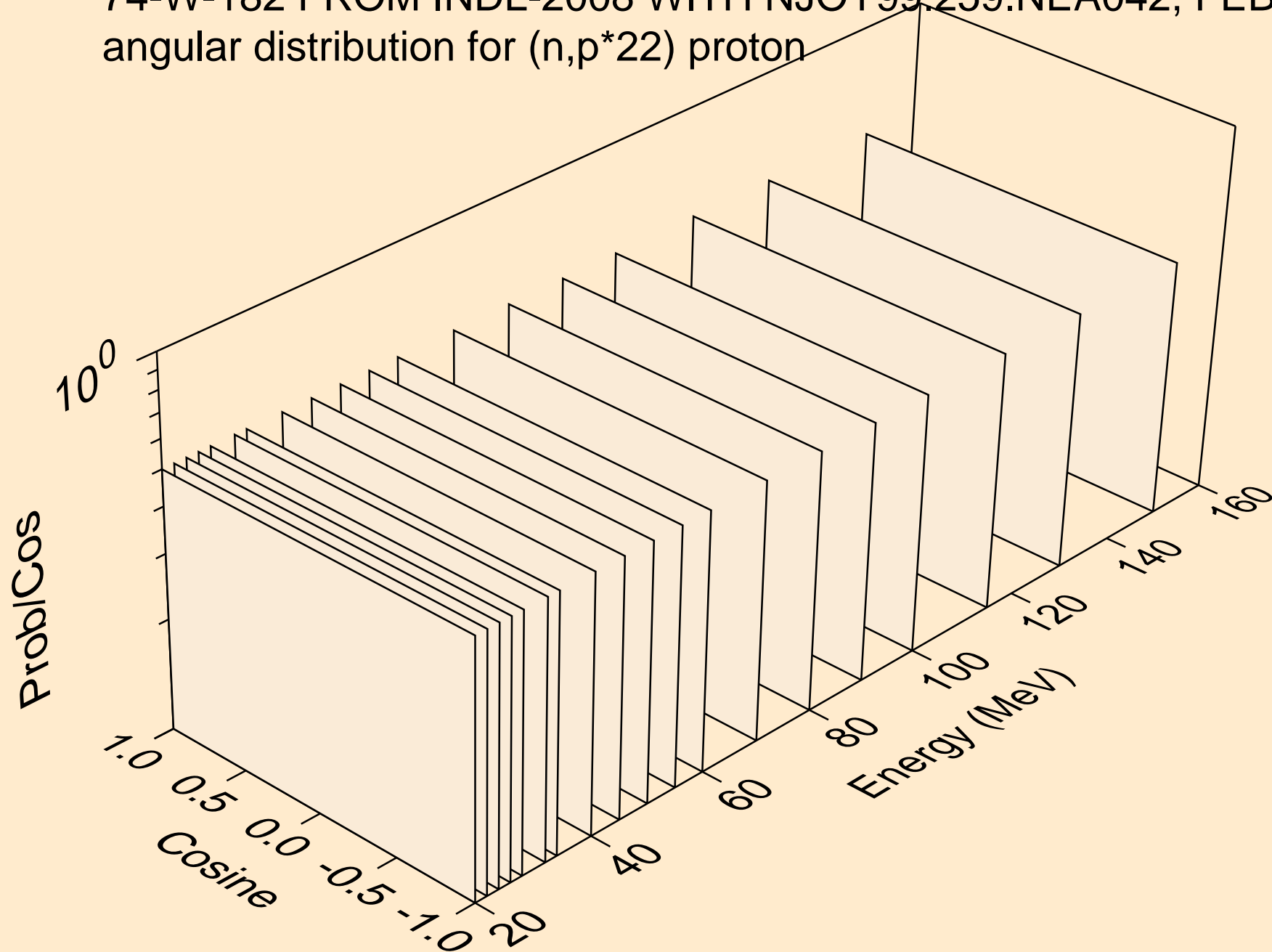

74-W-182 FROM INDL-2008 WITH NJOY99.259.NEA042, FEB. 200
angular distribution for (n,p*23) proton

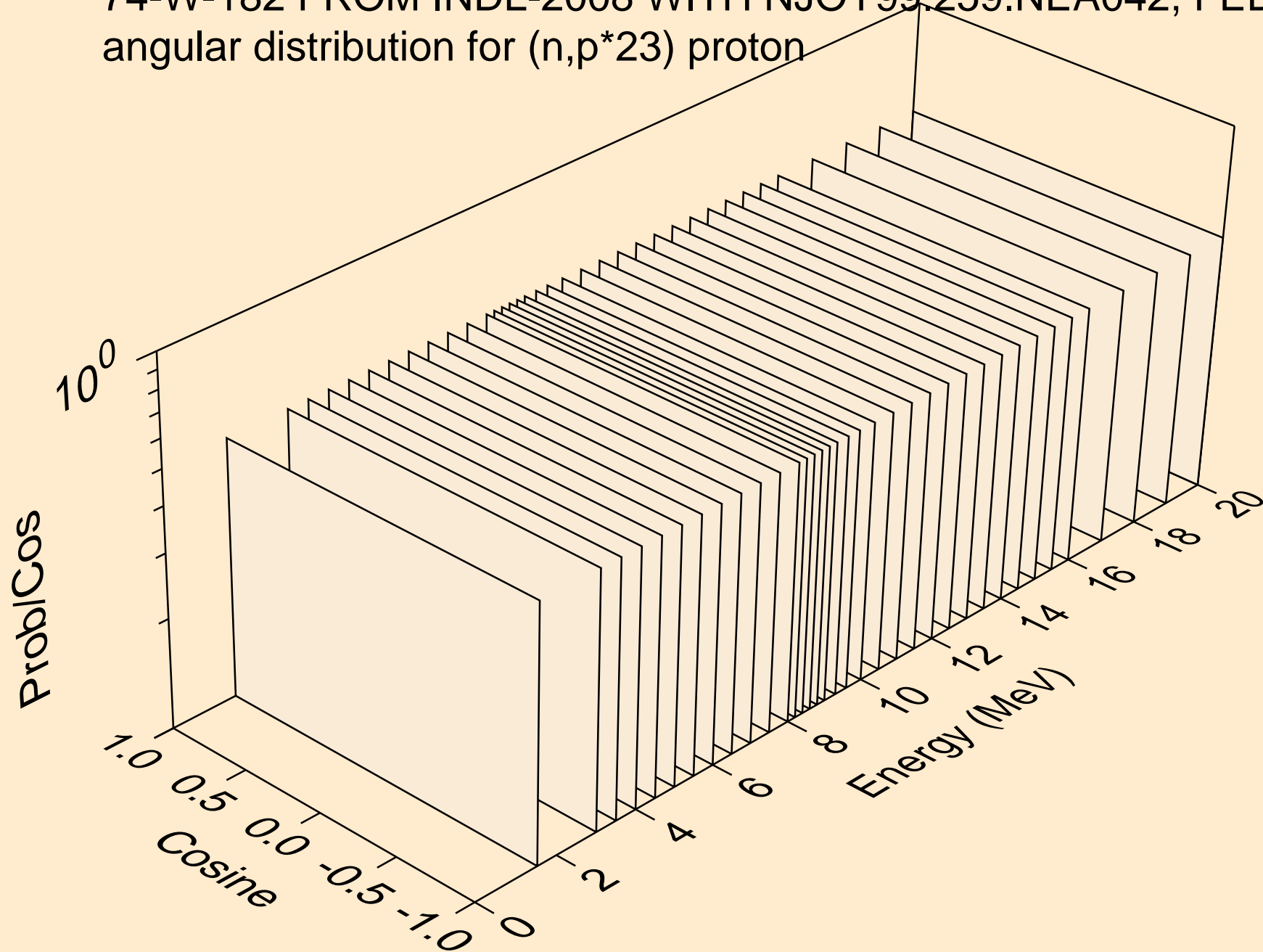

74-W-182 FROM INDL-2008 WITH NJOY99.259.NEA042, FEB. 200
angular distribution for (n,p*23) proton

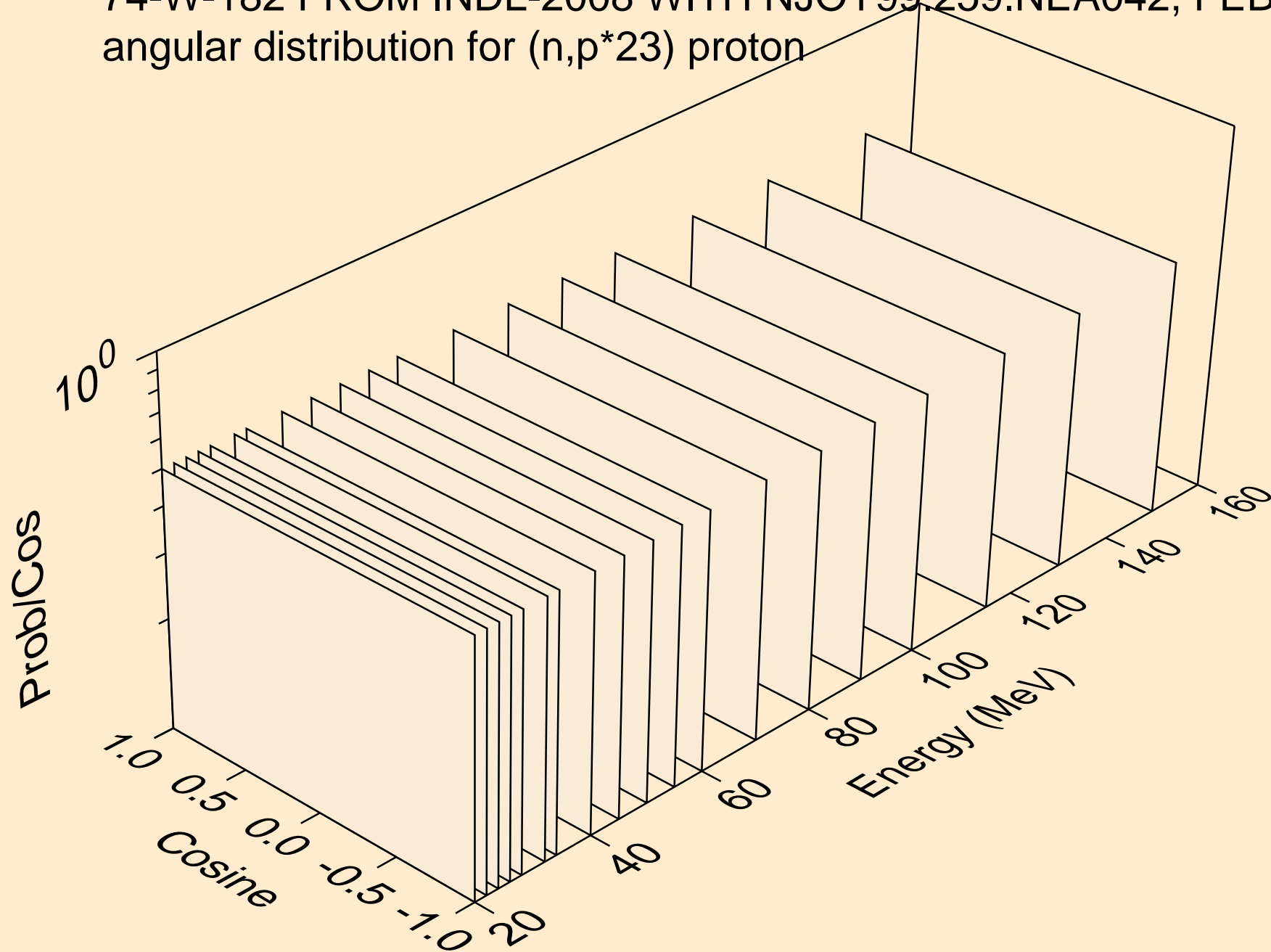

74-W-182 FROM INDL-2008 WITH NJOY99.259.NEA042, FEB. 200
angular distribution for (n,p*24) proton

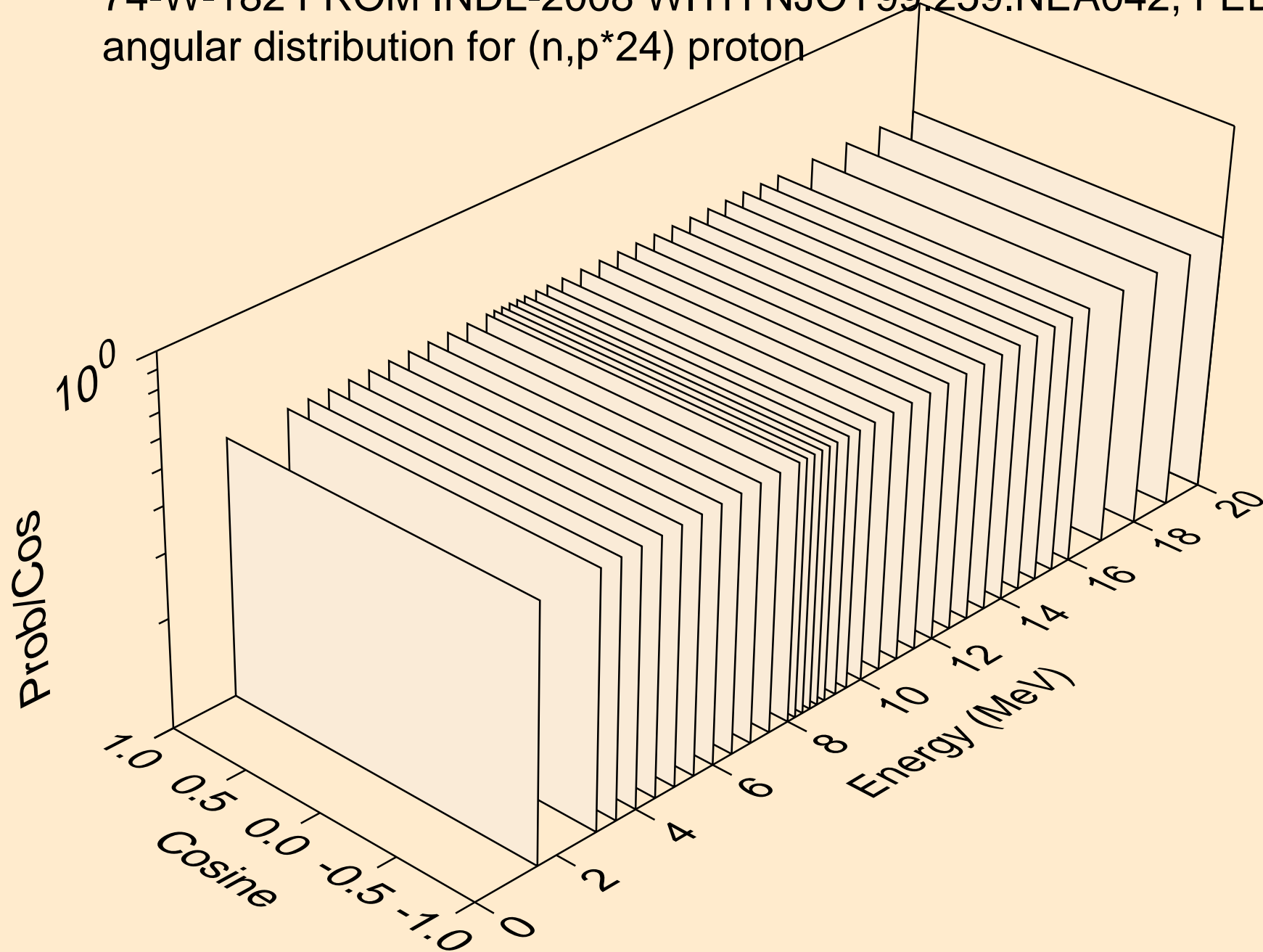

74-W-182 FROM INDL-2008 WITH NJOY99.259.NEA042, FEB. 200
angular distribution for (n,p*24) proton

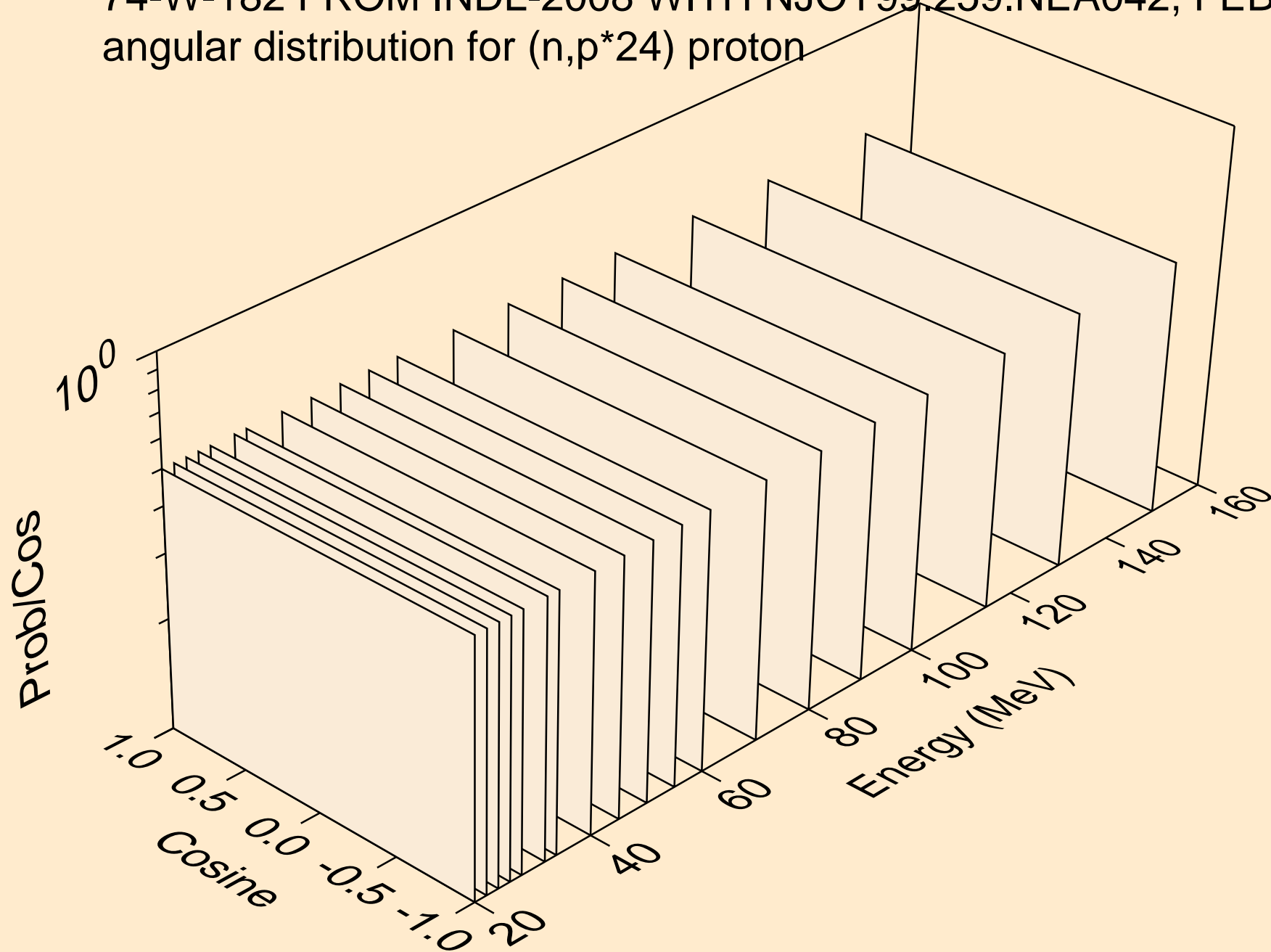

74-W-182 FROM INDL-2008 WITH NJOY99.259.NEA042, FEB. 200
angular distribution for (n,p*25) proton

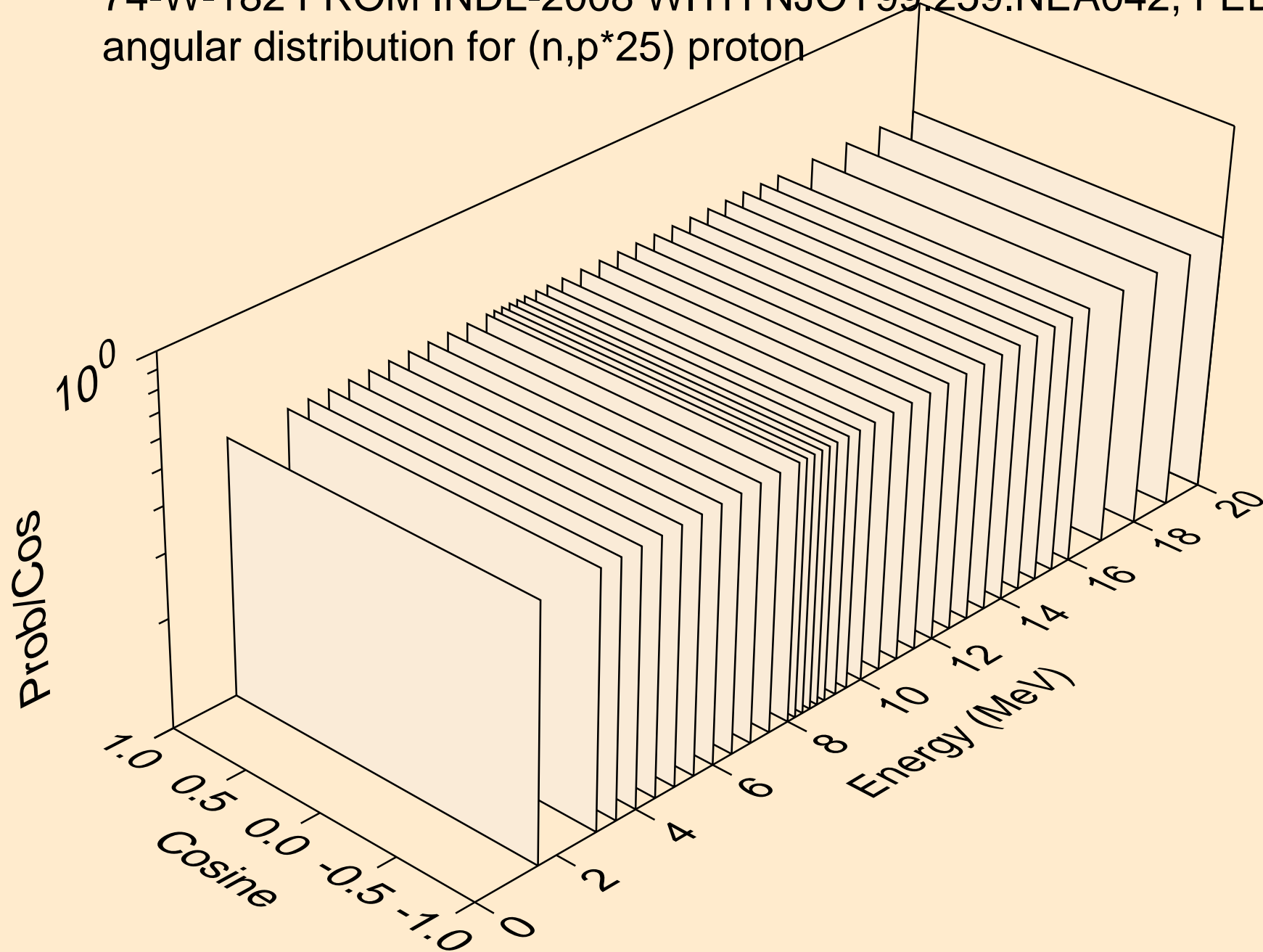

74-W-182 FROM INDL-2008 WITH NJOY99.259.NEA042, FEB. 200
angular distribution for (n,p*25) proton

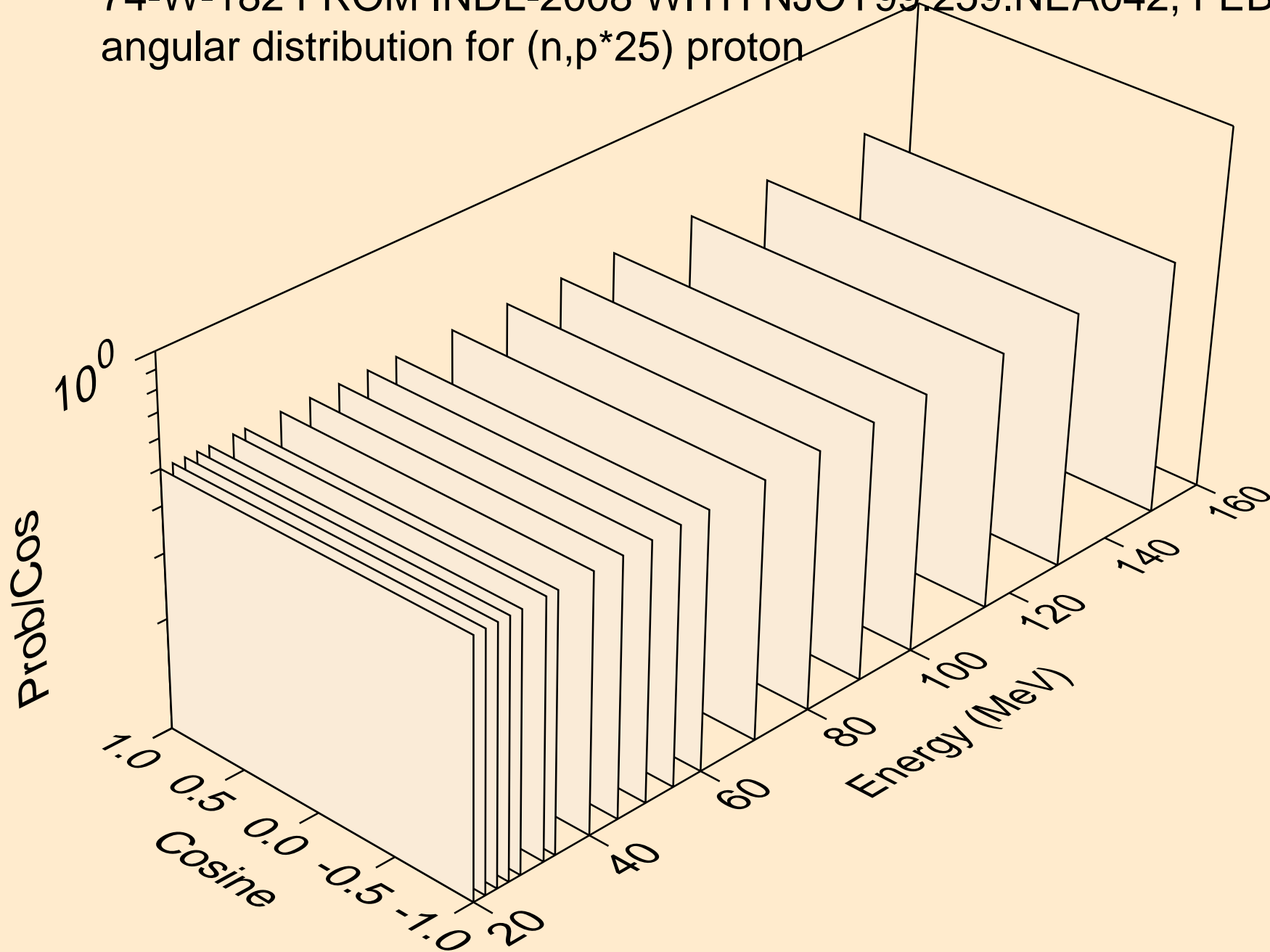

74-W-182 FROM INDL-2008 WITH NJOY99.259.NEA042, FEB. 200
angular distribution for (n,p*26) proton

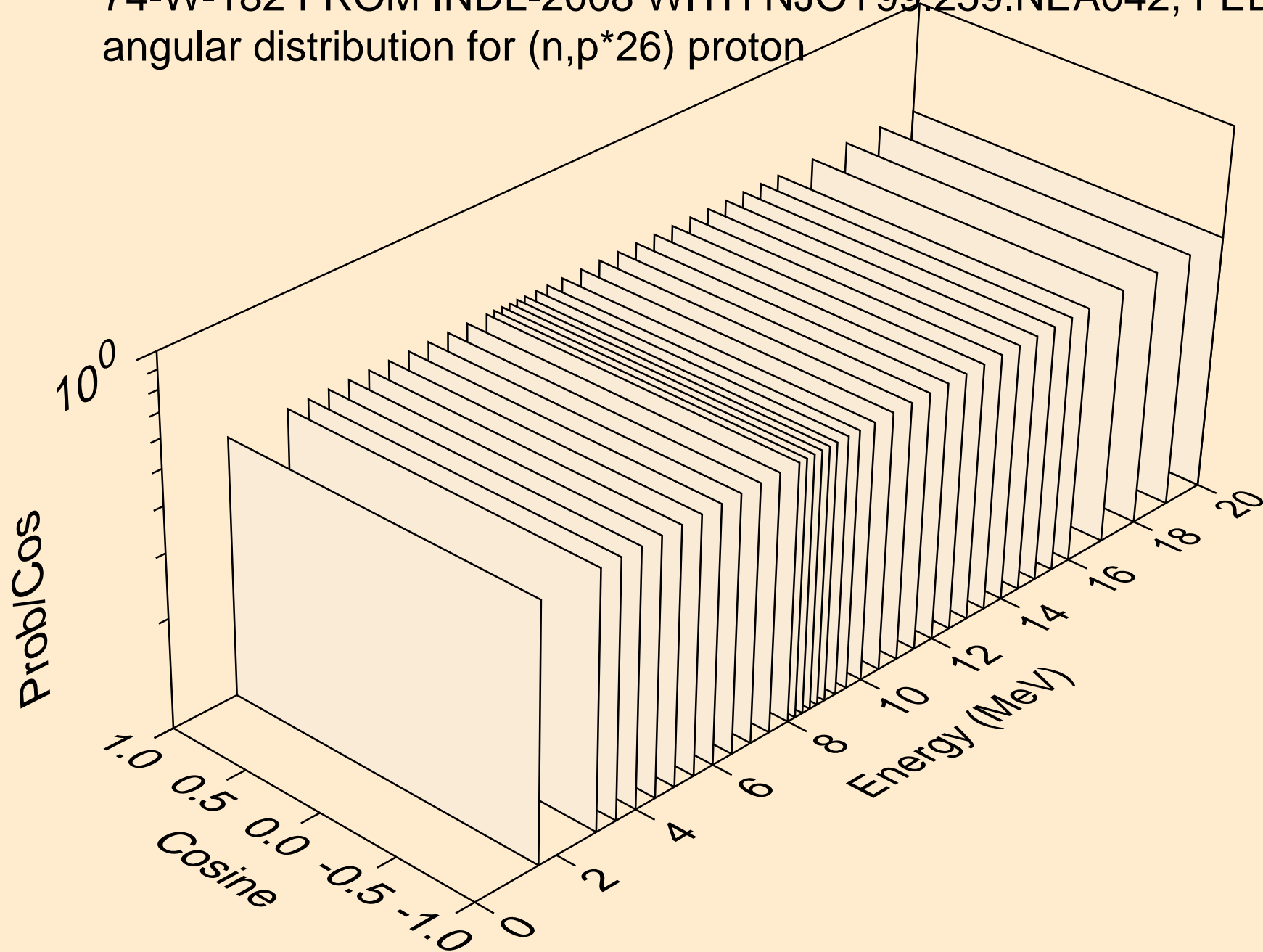

74-W-182 FROM INDL-2008 WITH NJOY99.259.NEA042, FEB. 200
angular distribution for (n,p*26) proton

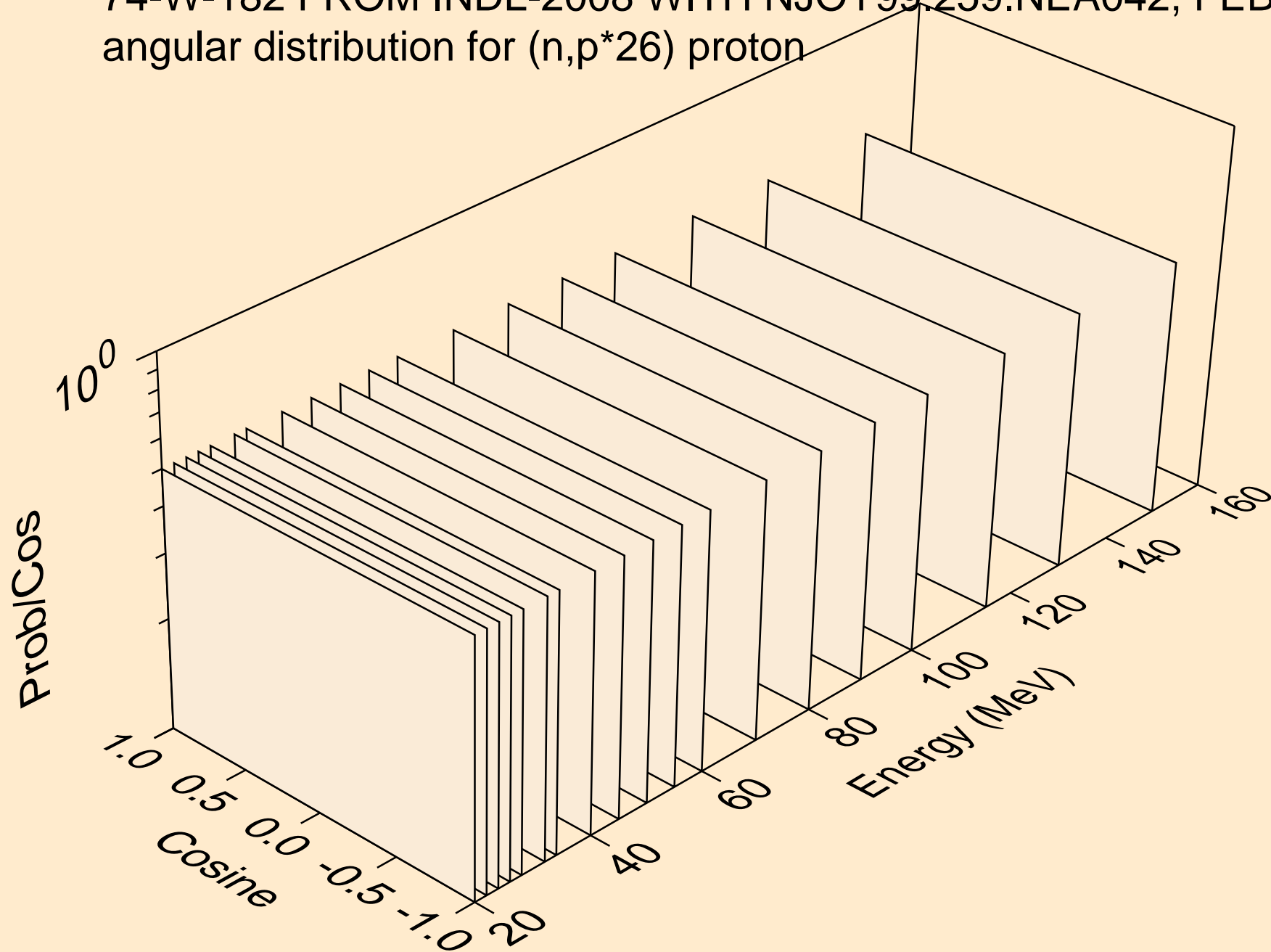

74-W-182 FROM INDL-2008 WITH NJOY99.259.NEA042, FEB. 200
angular distribution for (n,p*27) proton

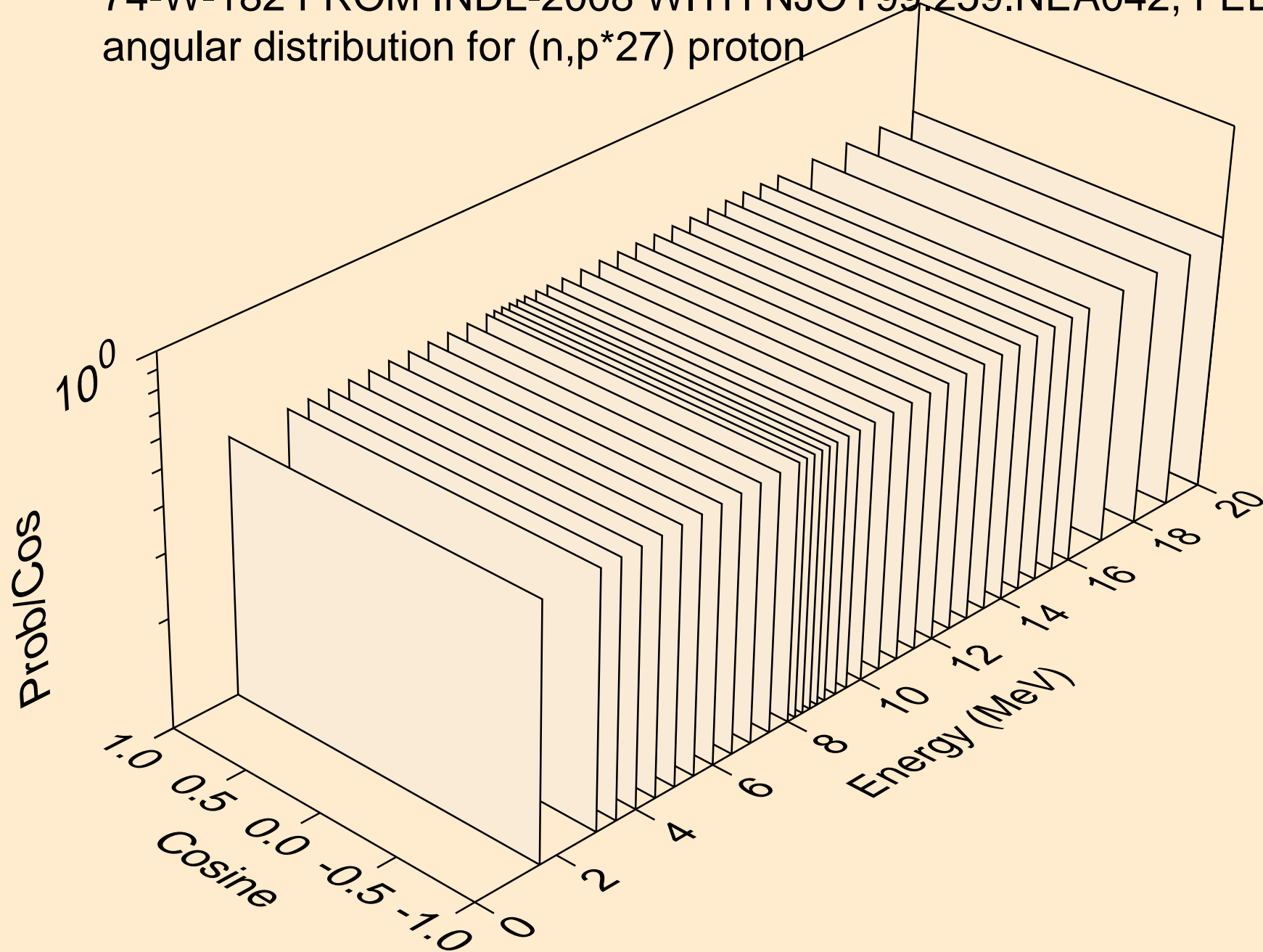

74-W-182 FROM INDL-2008 WITH NJOY99.259.NEA042, FEB. 200
angular distribution for (n,p*27) proton

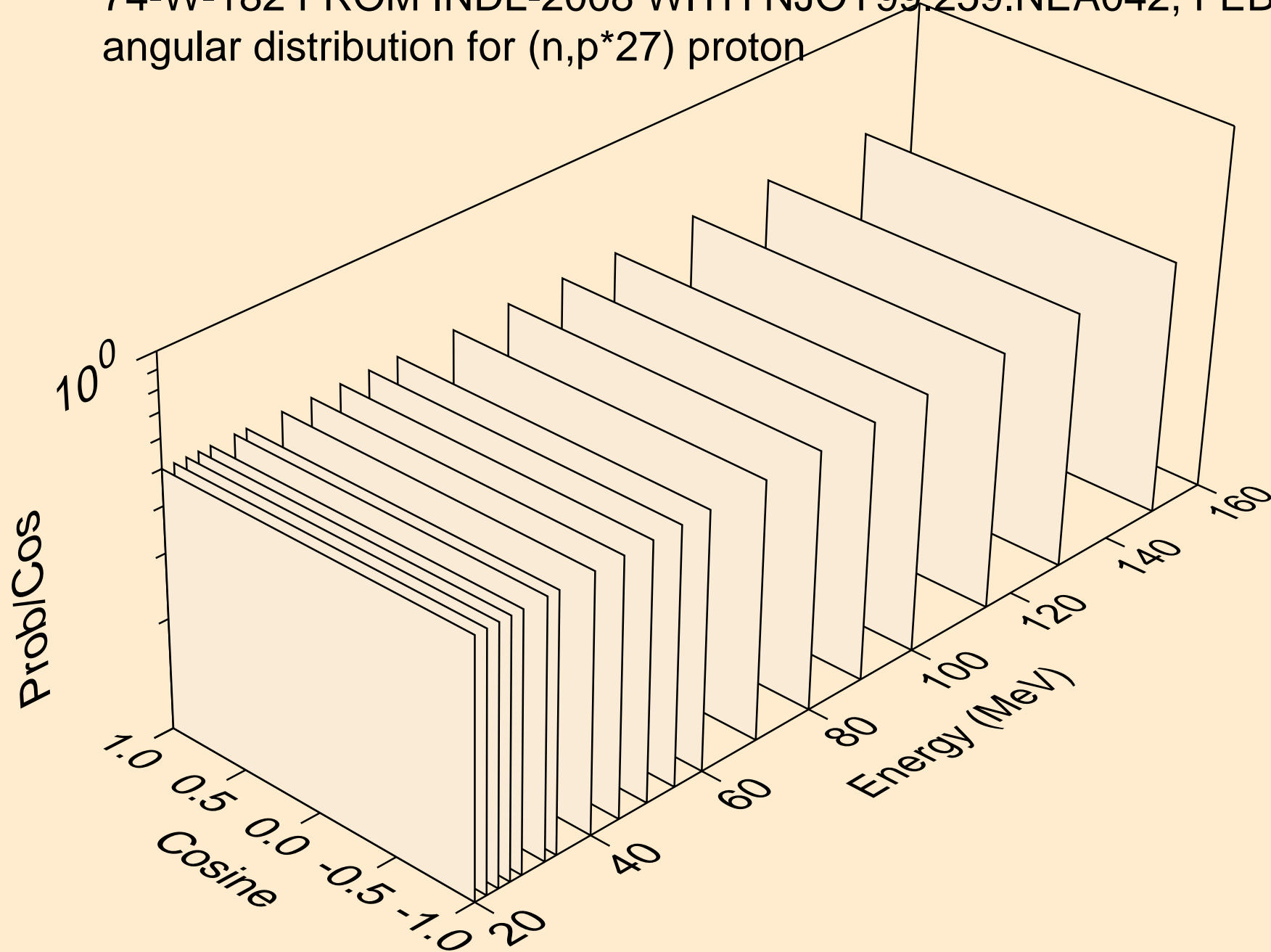

74-W-182 FROM INDL-2008 WITH NJOY99.259.NEA042, FEB. 200
angular distribution for (n,p*28) proton

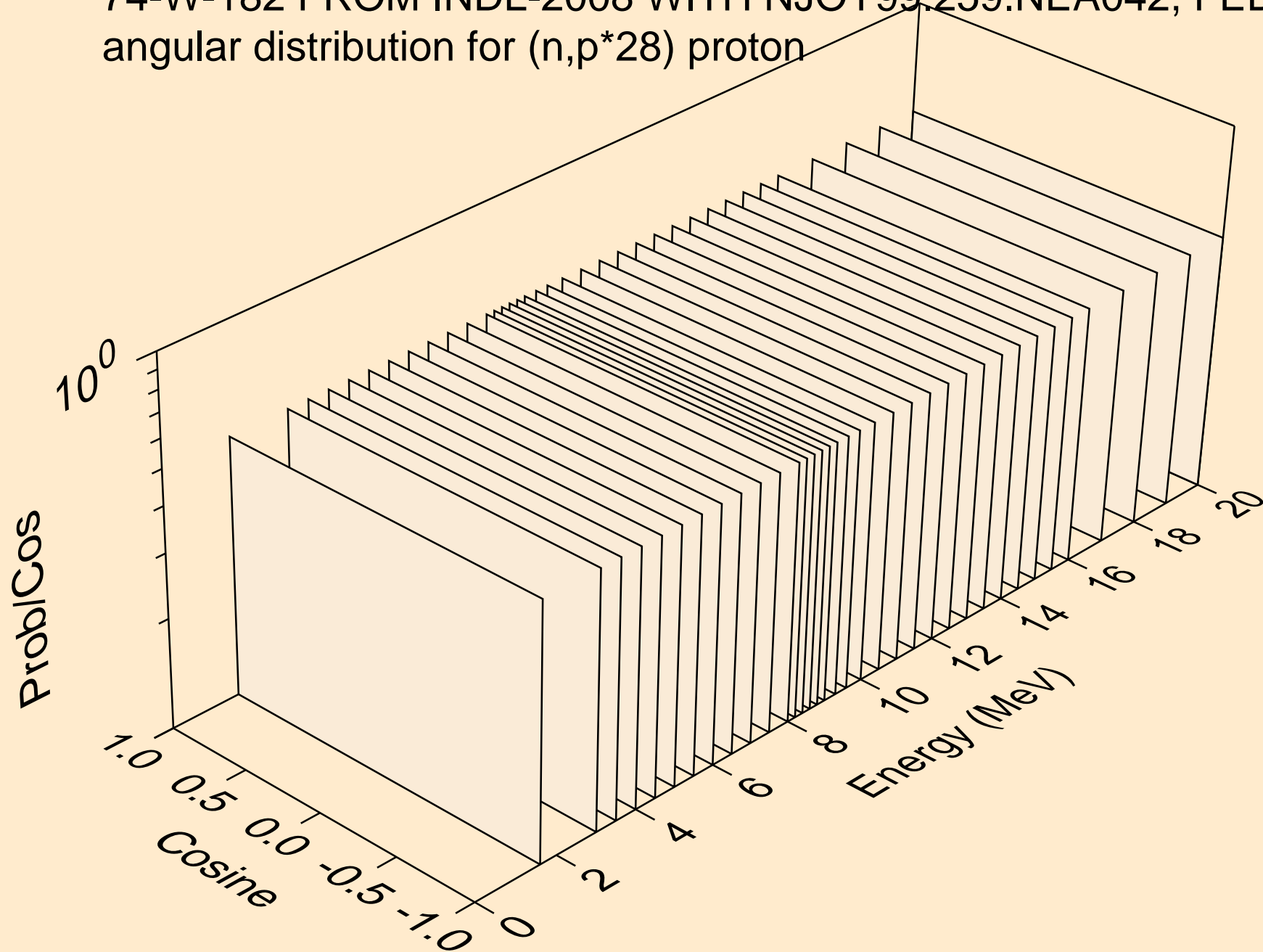

74-W-182 FROM INDL-2008 WITH NJOY99.259.NEA042, FEB. 200
angular distribution for (n,p*28) proton

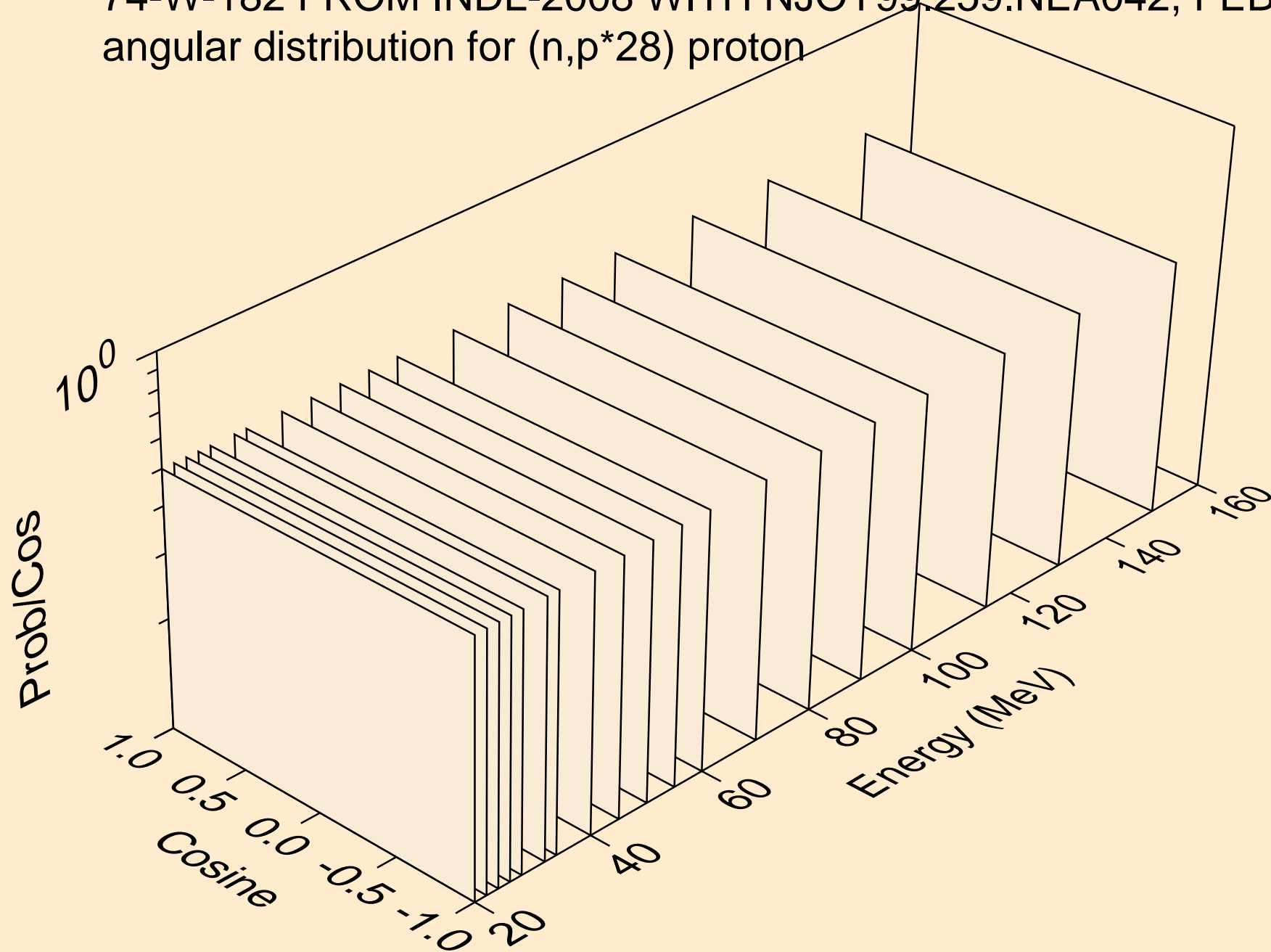

74-W-182 FROM INDL-2008 WITH NJOY99.259.NEA042, FEB. 200
angular distribution for (n,p*29) proton

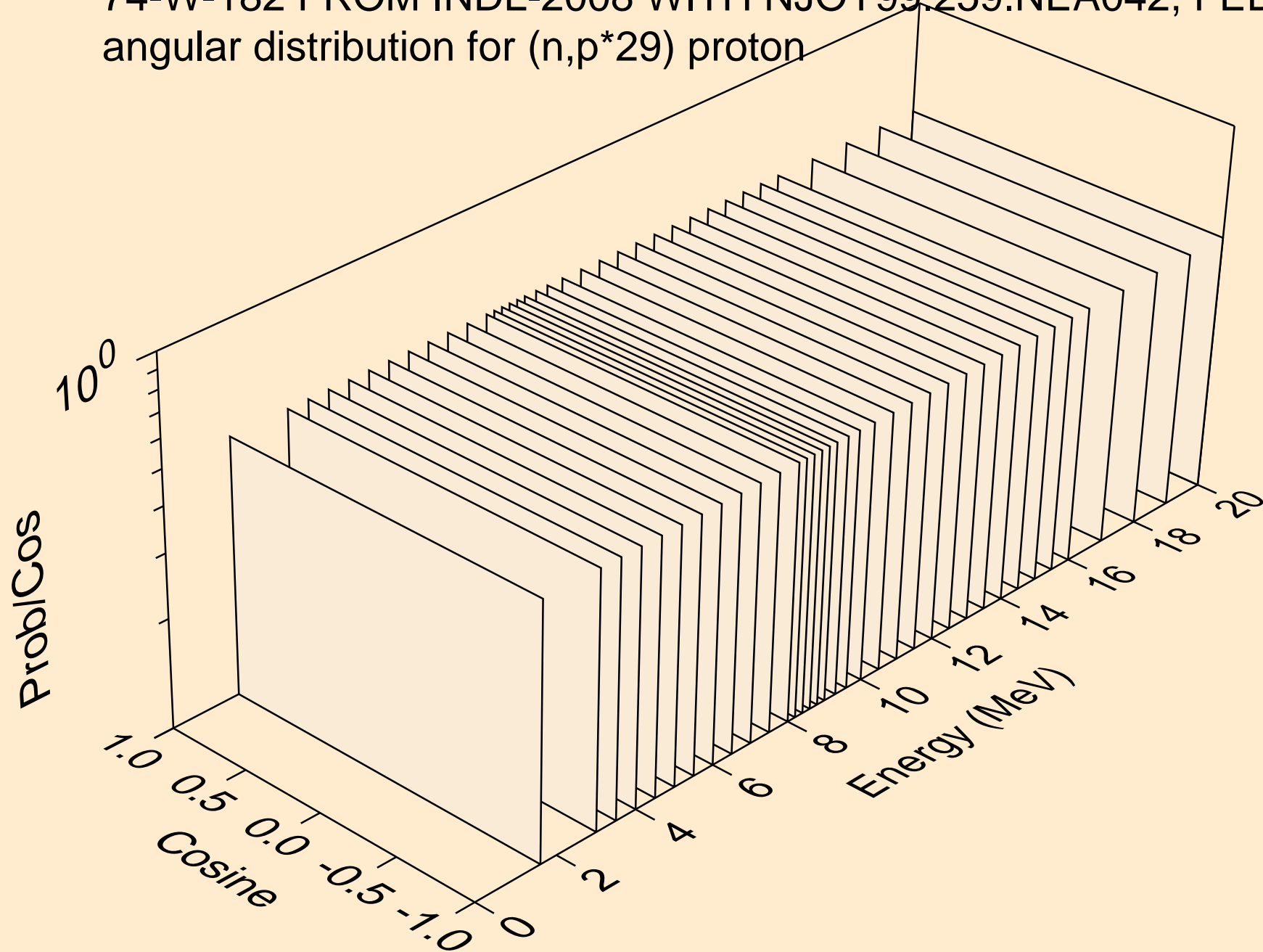

74-W-182 FROM INDL-2008 WITH NJOY99.259.NEA042, FEB. 200
angular distribution for (n,p*29) proton

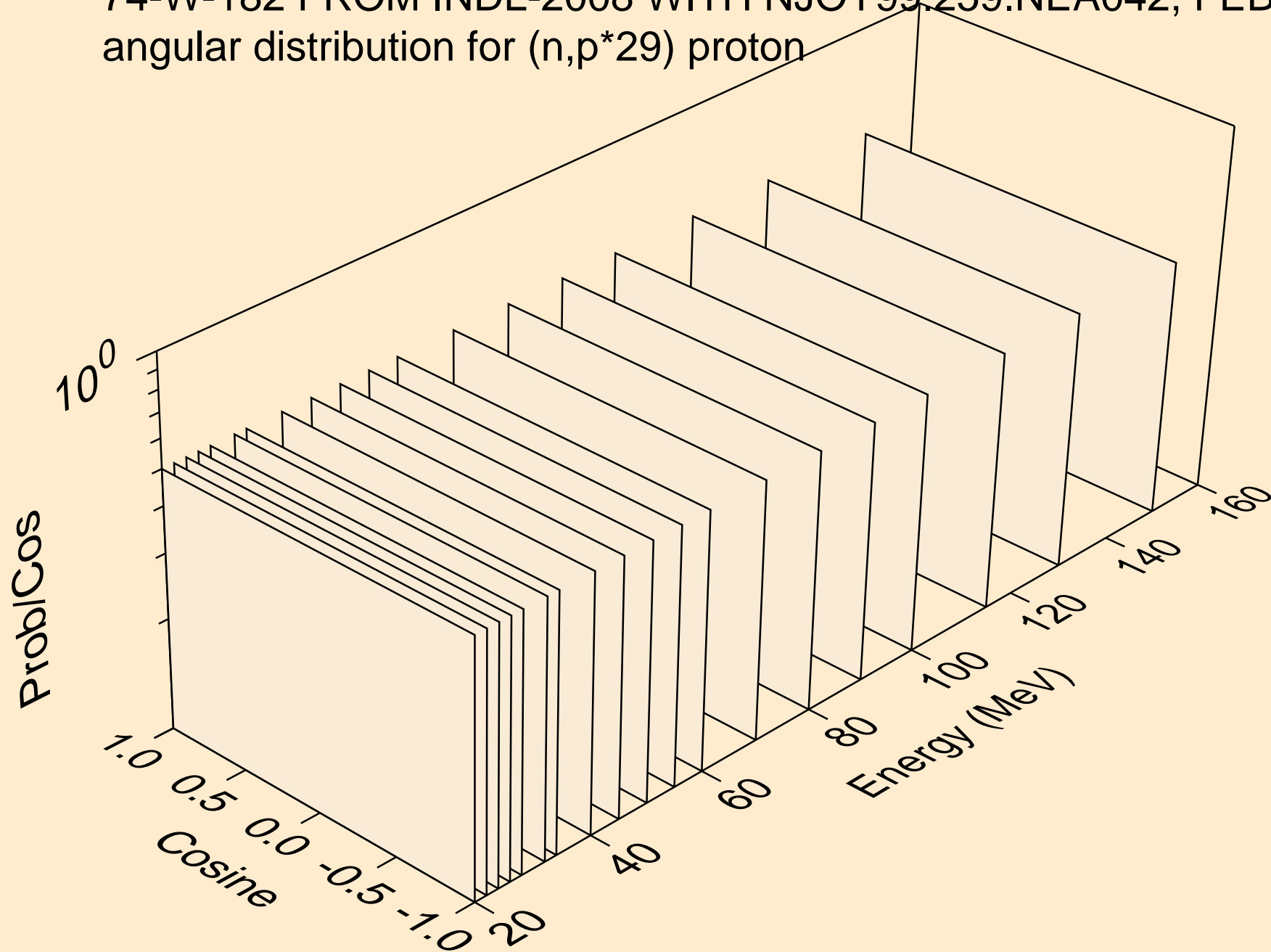

74-W-182 FROM INDL-2008 WITH NJOY99.259.NEA042, FEB. 200
protons from (n,p*c)

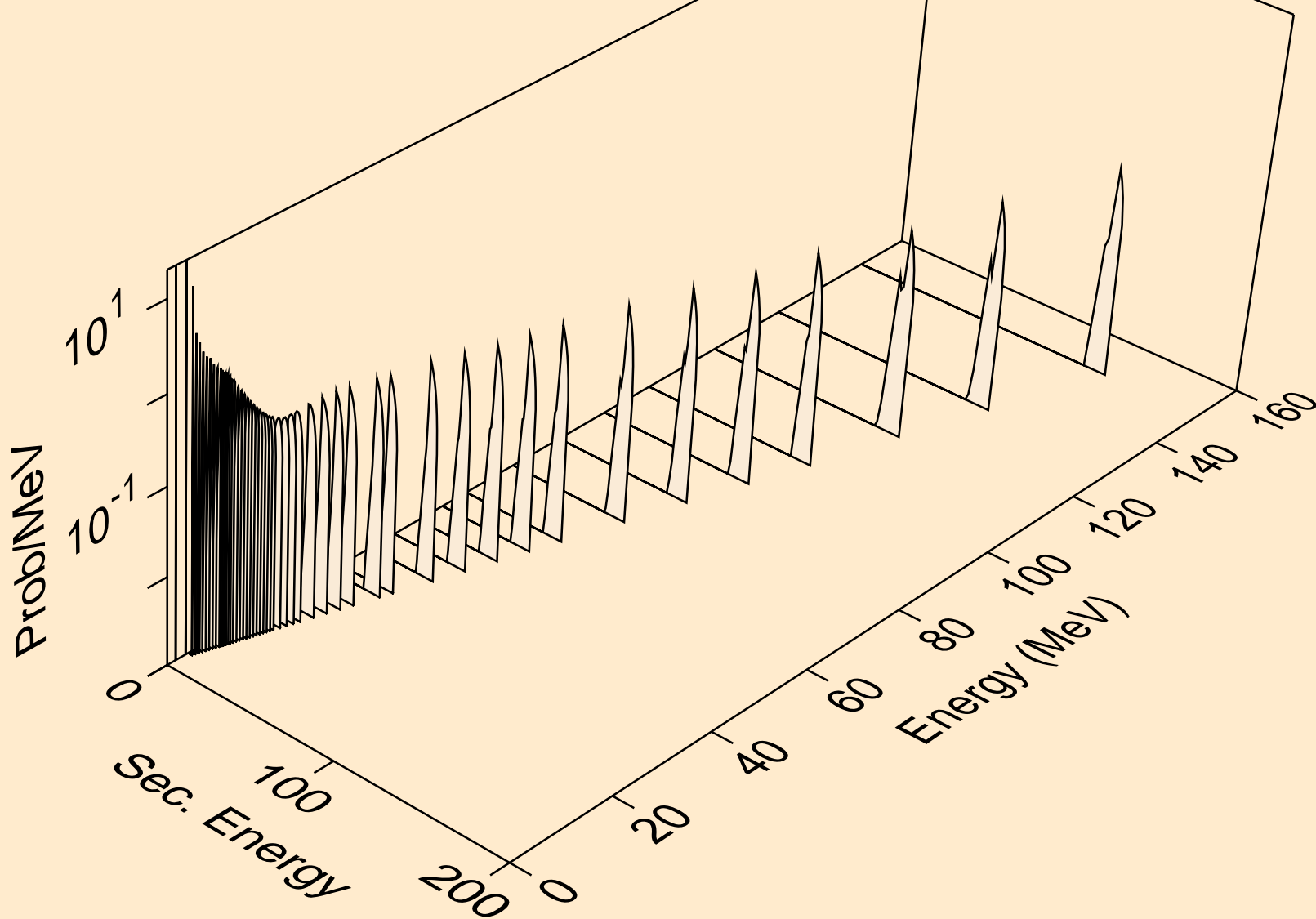

74-W-182 FROM INDL-2008 WITH NJOY99.259.NEA042, FEB. 200
alphas from (n,x)

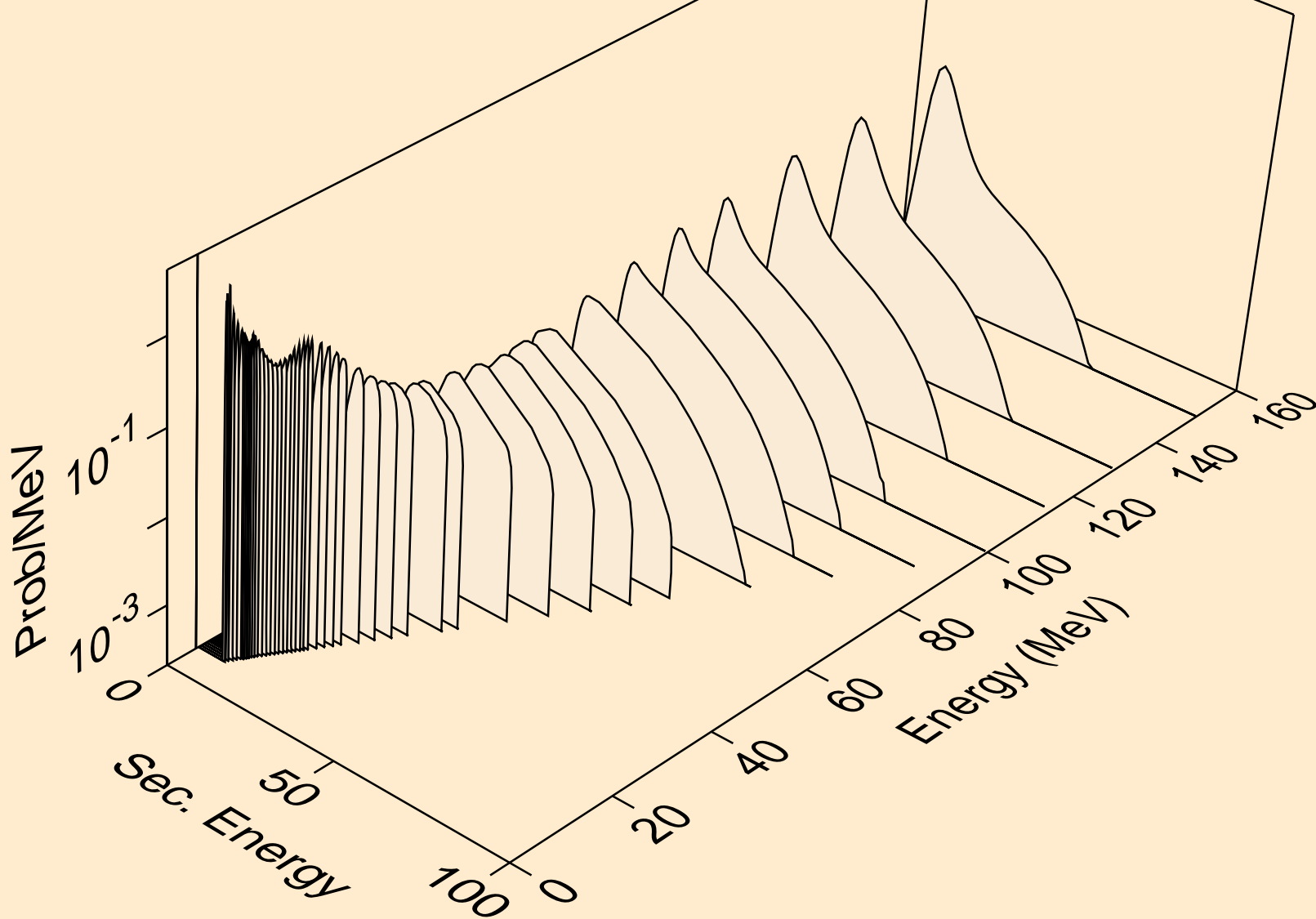

74-W-182 FROM INDL-2008 WITH NJOY99.259.NEA042, FEB. 200
angular distribution for (n,a*0) alpha

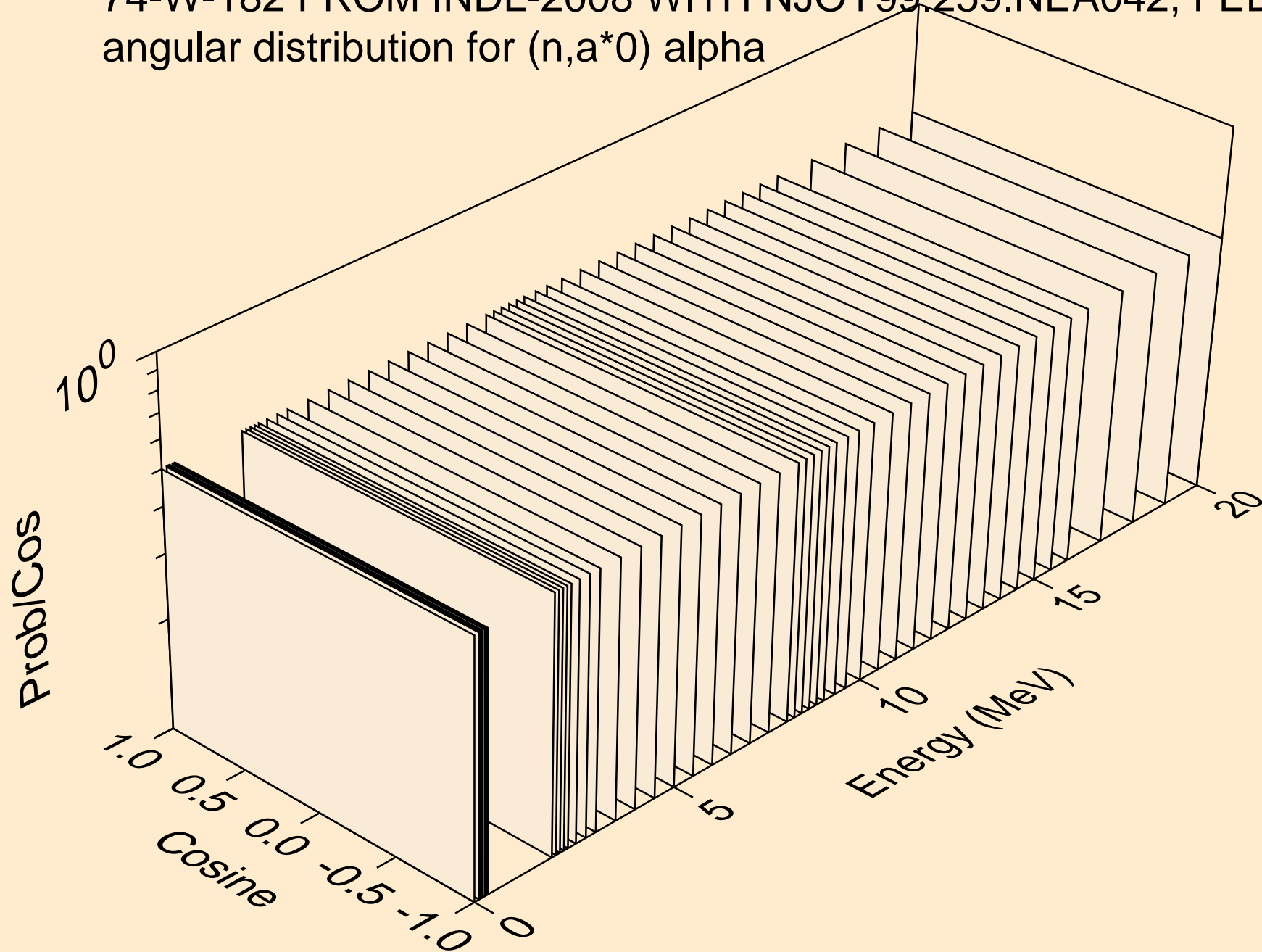

74-W-182 FROM INDL-2008 WITH NJOY99.259.NEA042, FEB. 200
angular distribution for (n,a*0) alpha

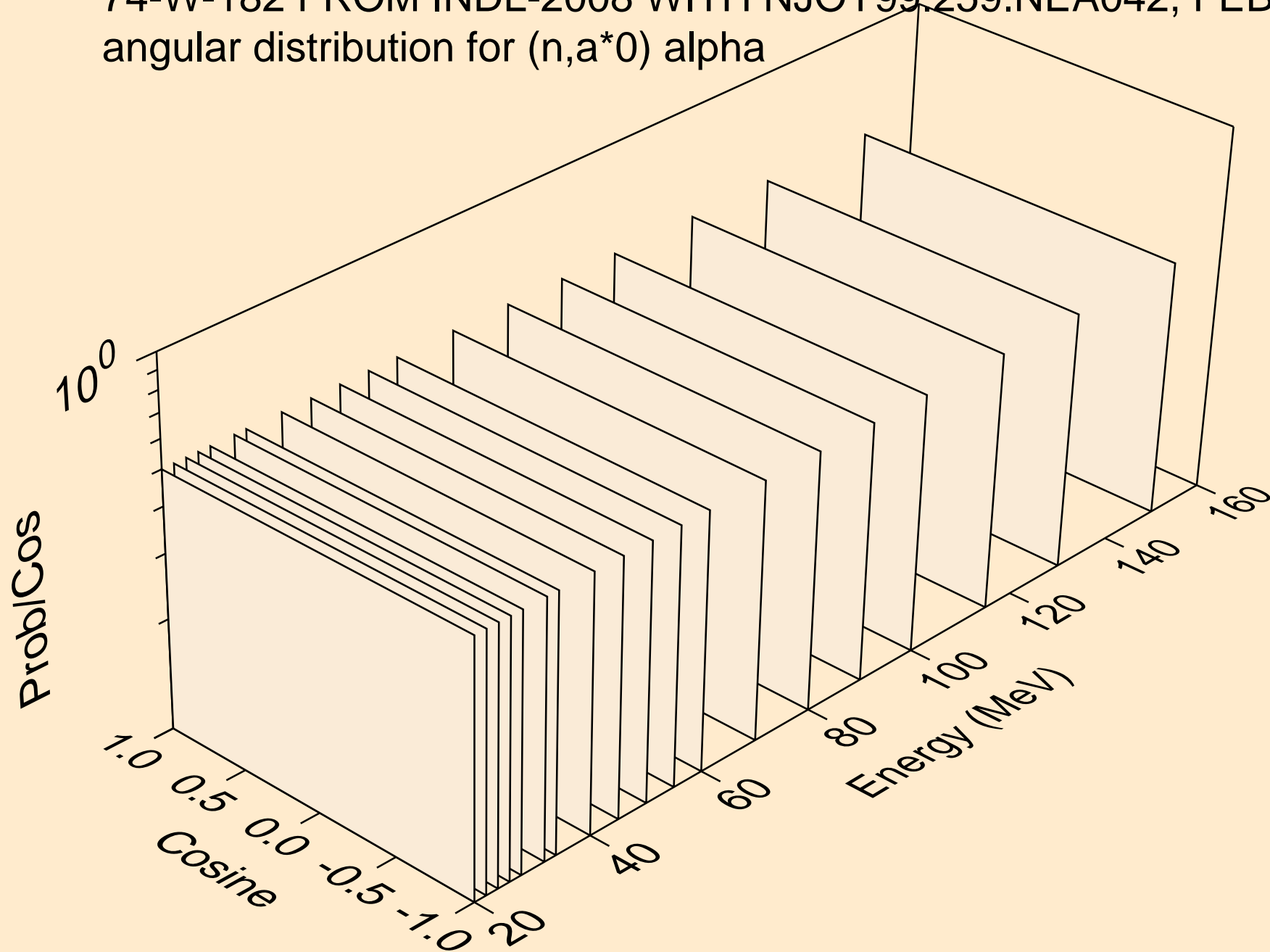

74-W-182 FROM INDL-2008 WITH NJOY99.259.NEA042, FEB. 200
angular distribution for (n,a*1) alpha

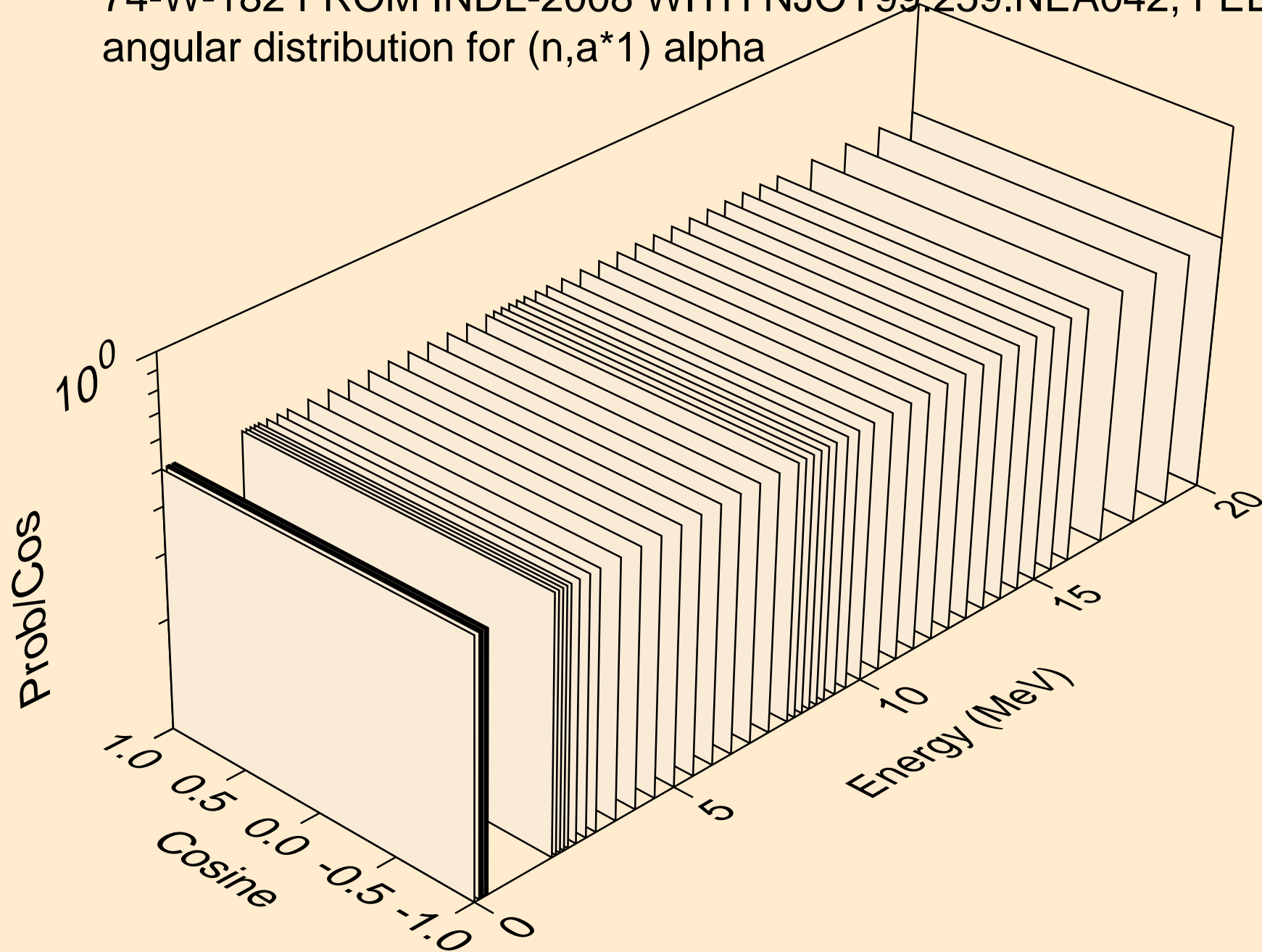

74-W-182 FROM INDL-2008 WITH NJOY99.259.NEA042, FEB. 200
angular distribution for (n,a*1) alpha

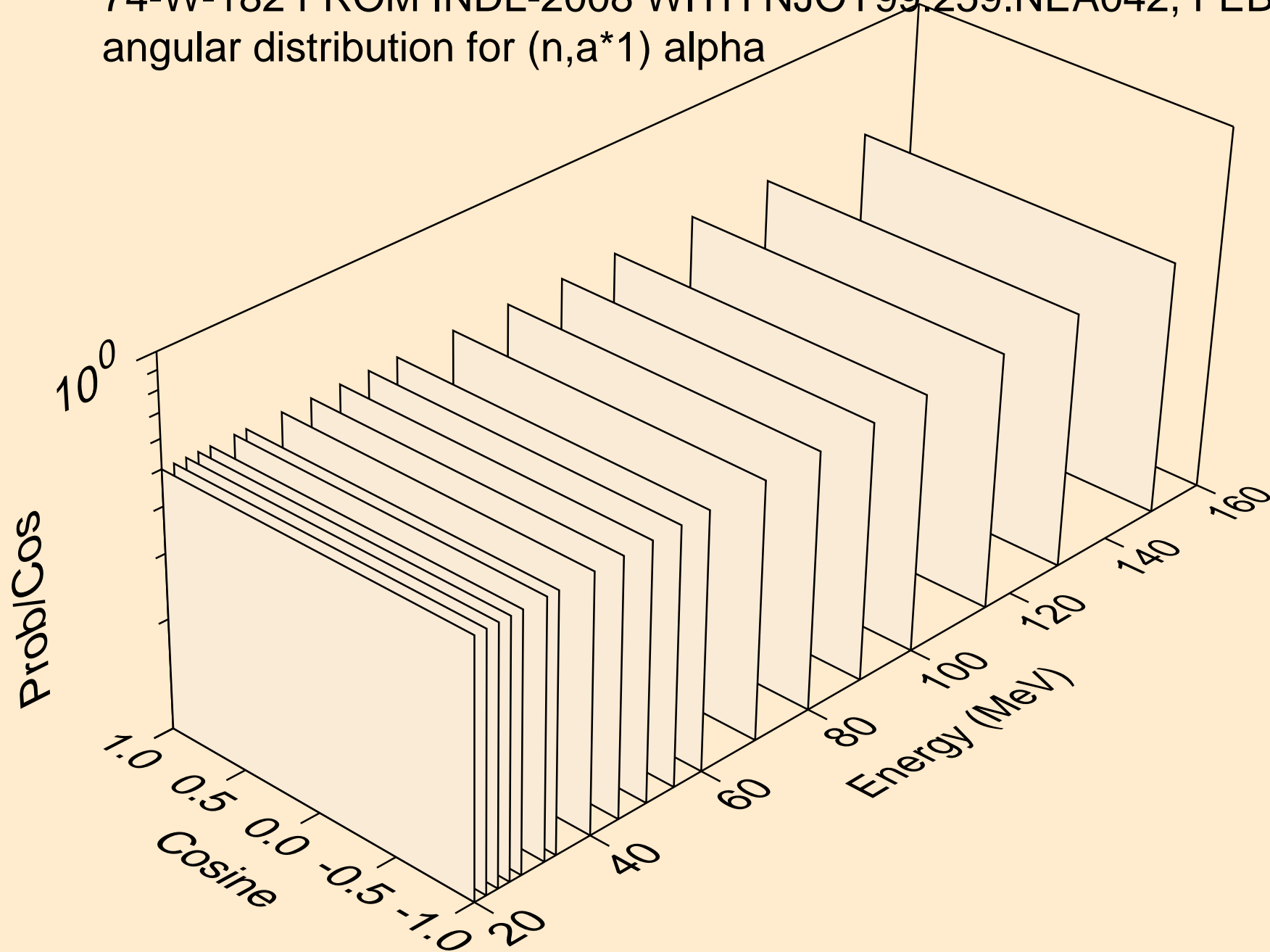

74-W-182 FROM INDL-2008 WITH NJOY99.259.NEA042, FEB. 200
angular distribution for (n,a*2) alpha

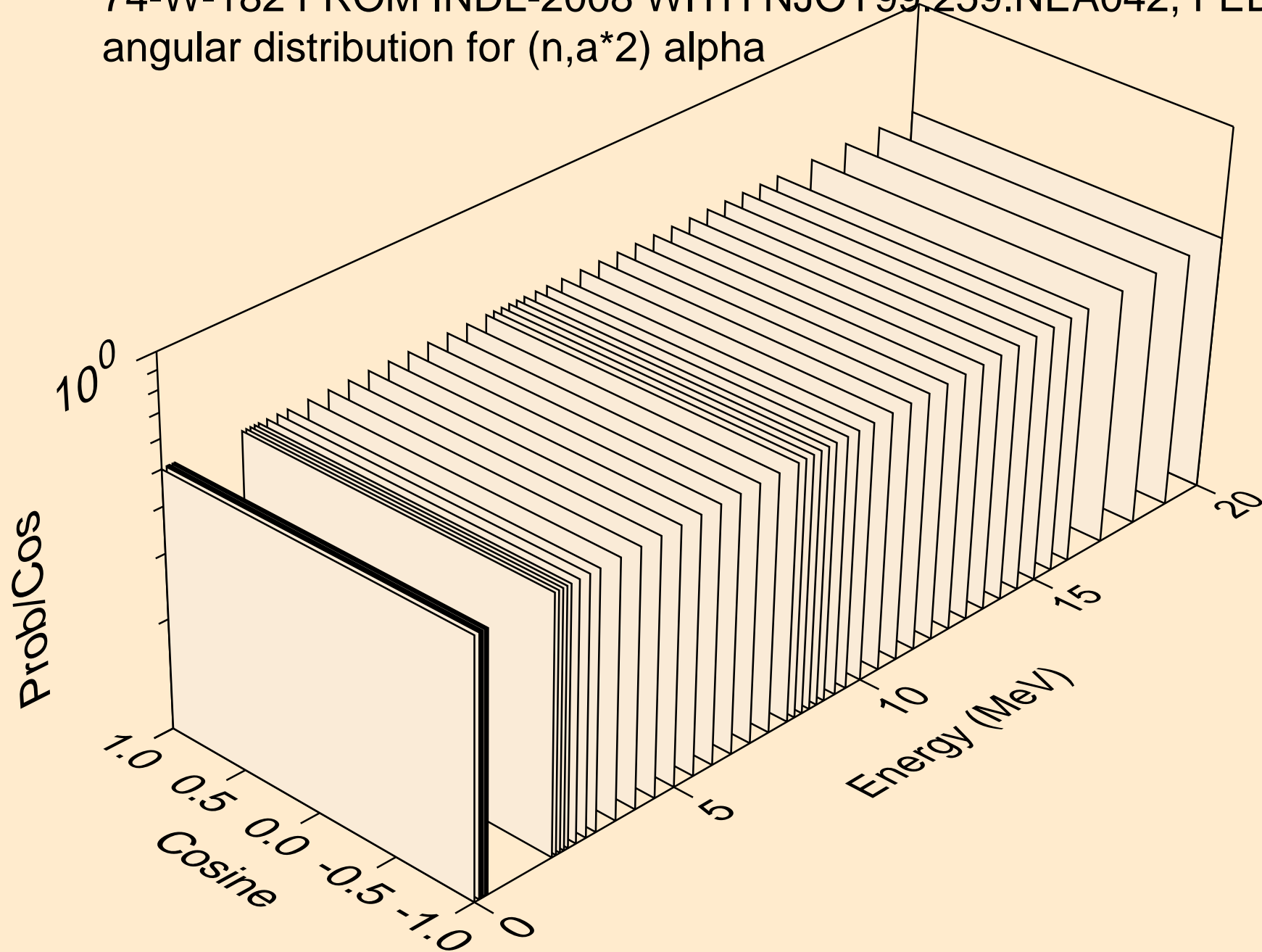

74-W-182 FROM INDL-2008 WITH NJOY99.259.NEA042, FEB. 200
angular distribution for (n,a*2) alpha

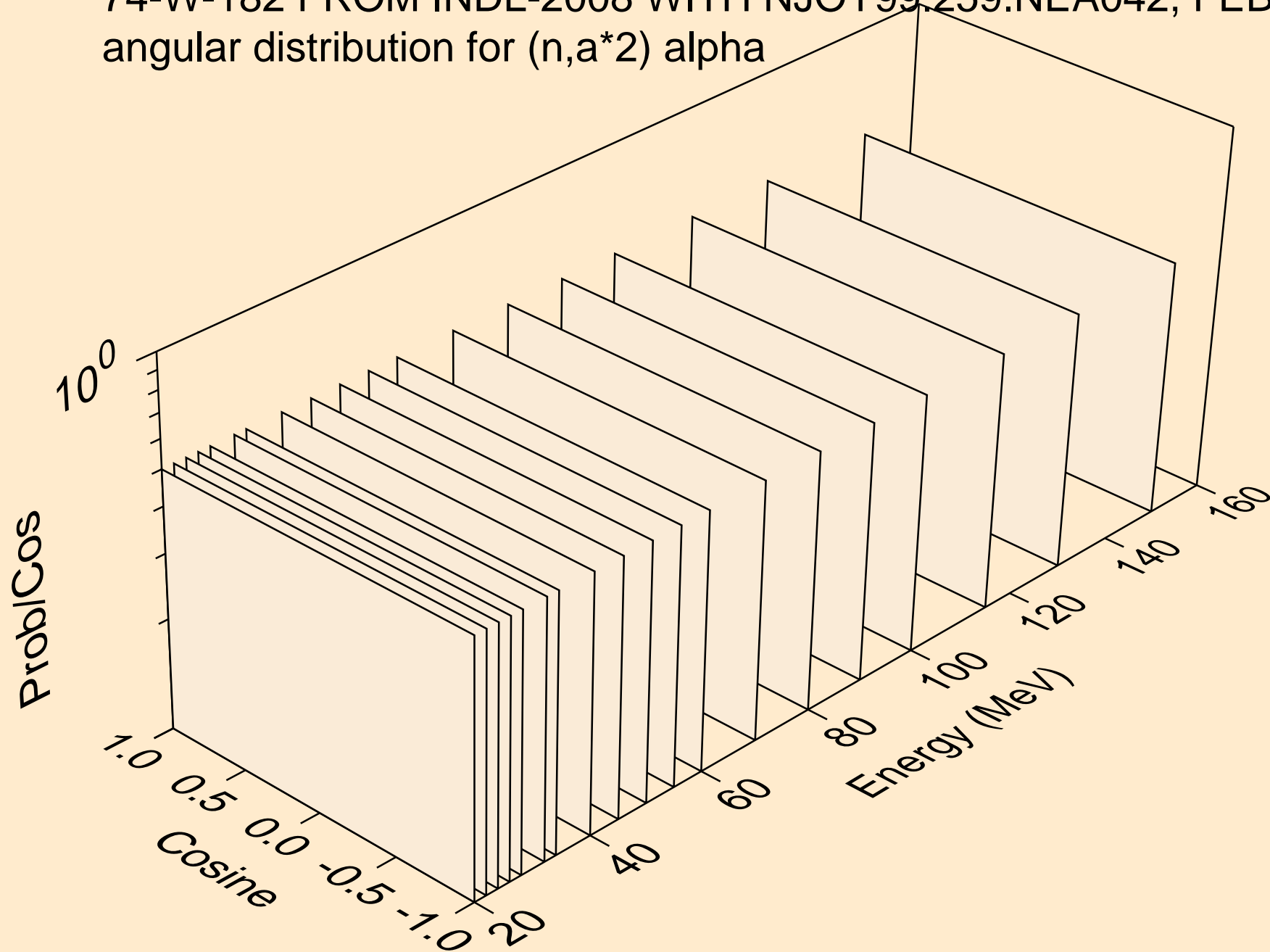

74-W-182 FROM INDL-2008 WITH NJOY99.259.NEA042, FEB. 200
angular distribution for (n,a*3) alpha

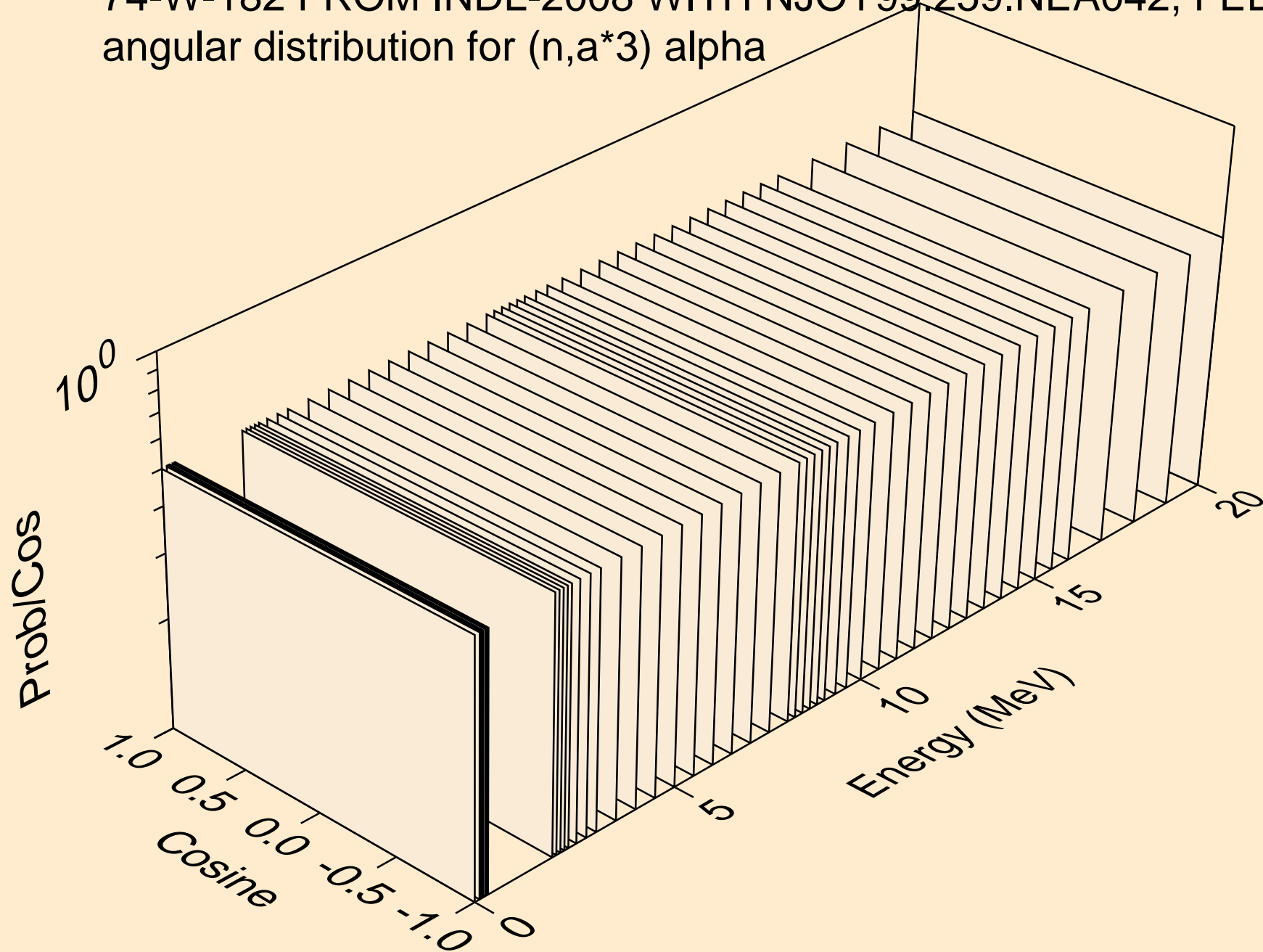

74-W-182 FROM INDL-2008 WITH NJOY99.259.NEA042, FEB. 200
angular distribution for (n,a*3) alpha

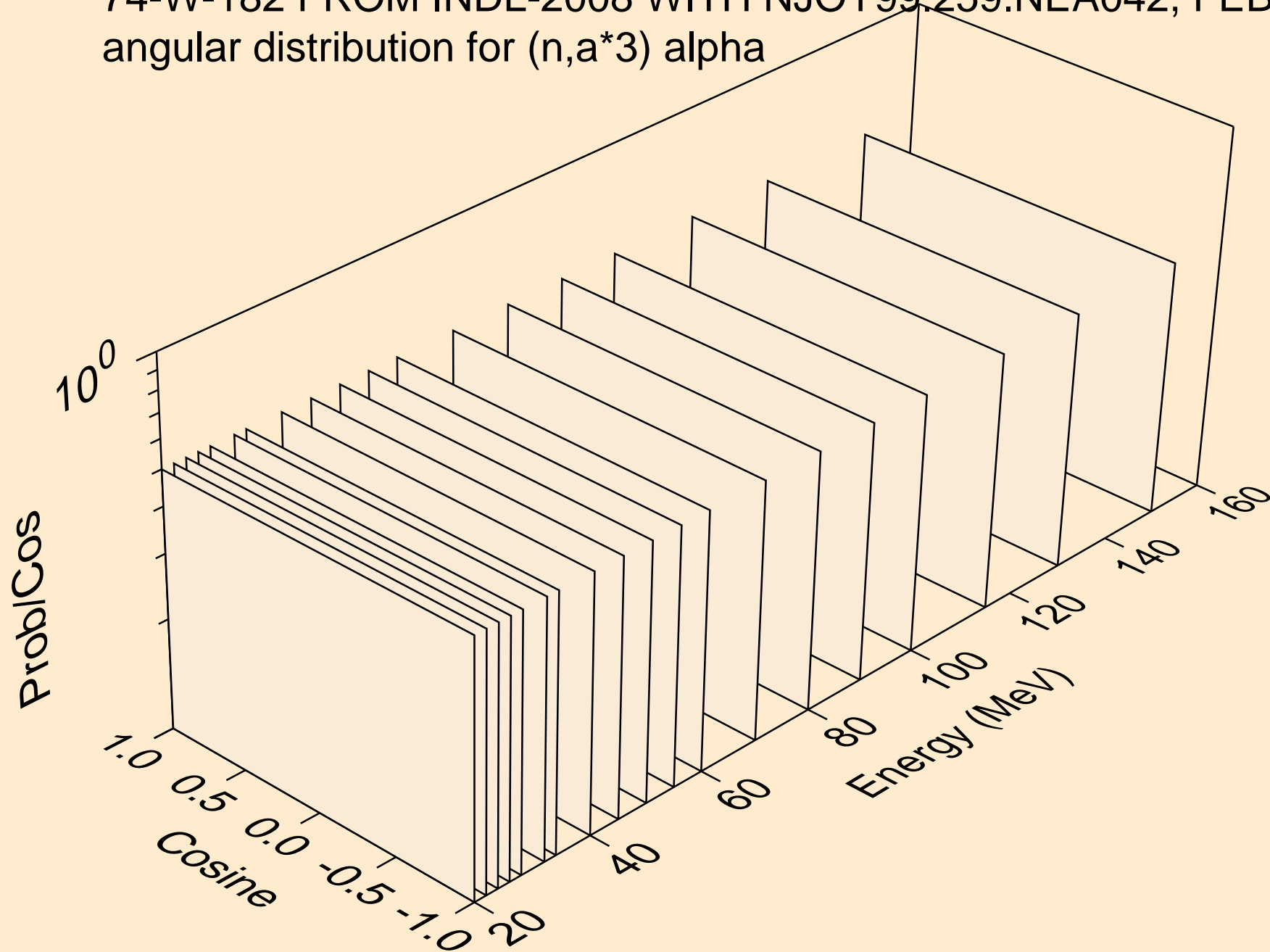

74-W-182 FROM INDL-2008 WITH NJOY99.259.NEA042, FEB. 200
angular distribution for (n,a*4) alpha

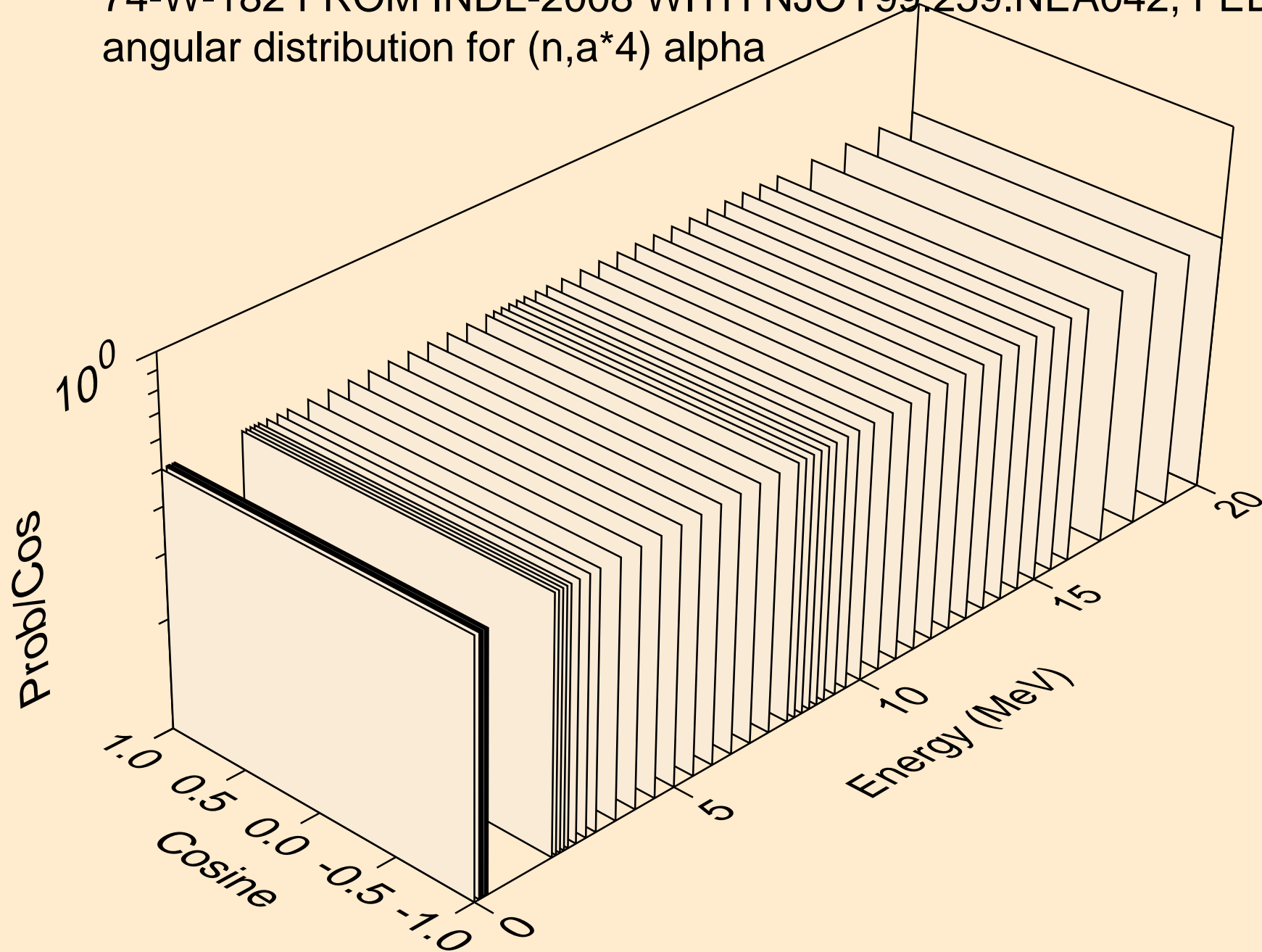

74-W-182 FROM INDL-2008 WITH NJOY99.259.NEA042, FEB. 200
angular distribution for (n,a*4) alpha

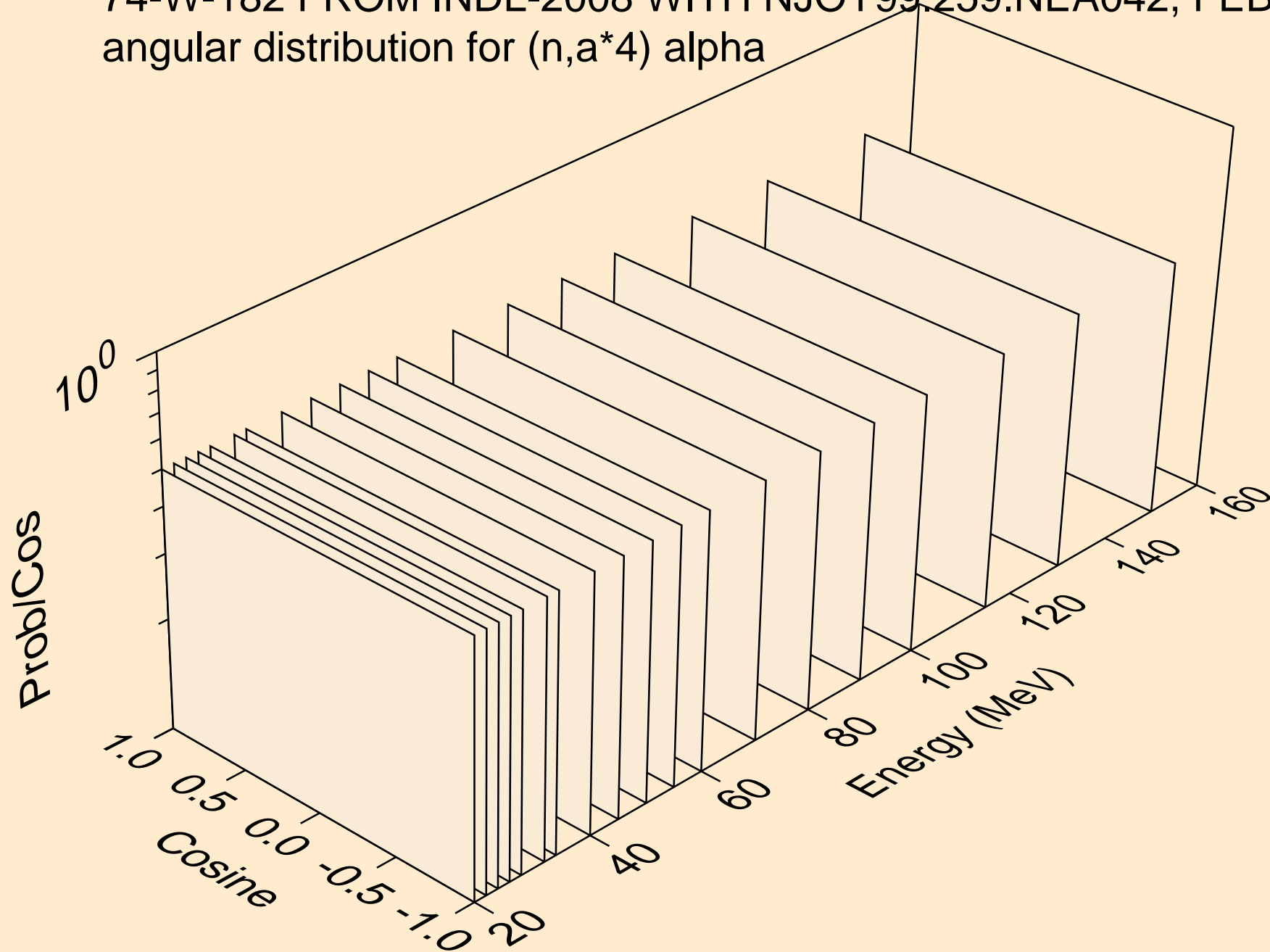

74-W-182 FROM INDL-2008 WITH NJOY99.259.NEA042, FEB. 200
angular distribution for (n,a*5) alpha

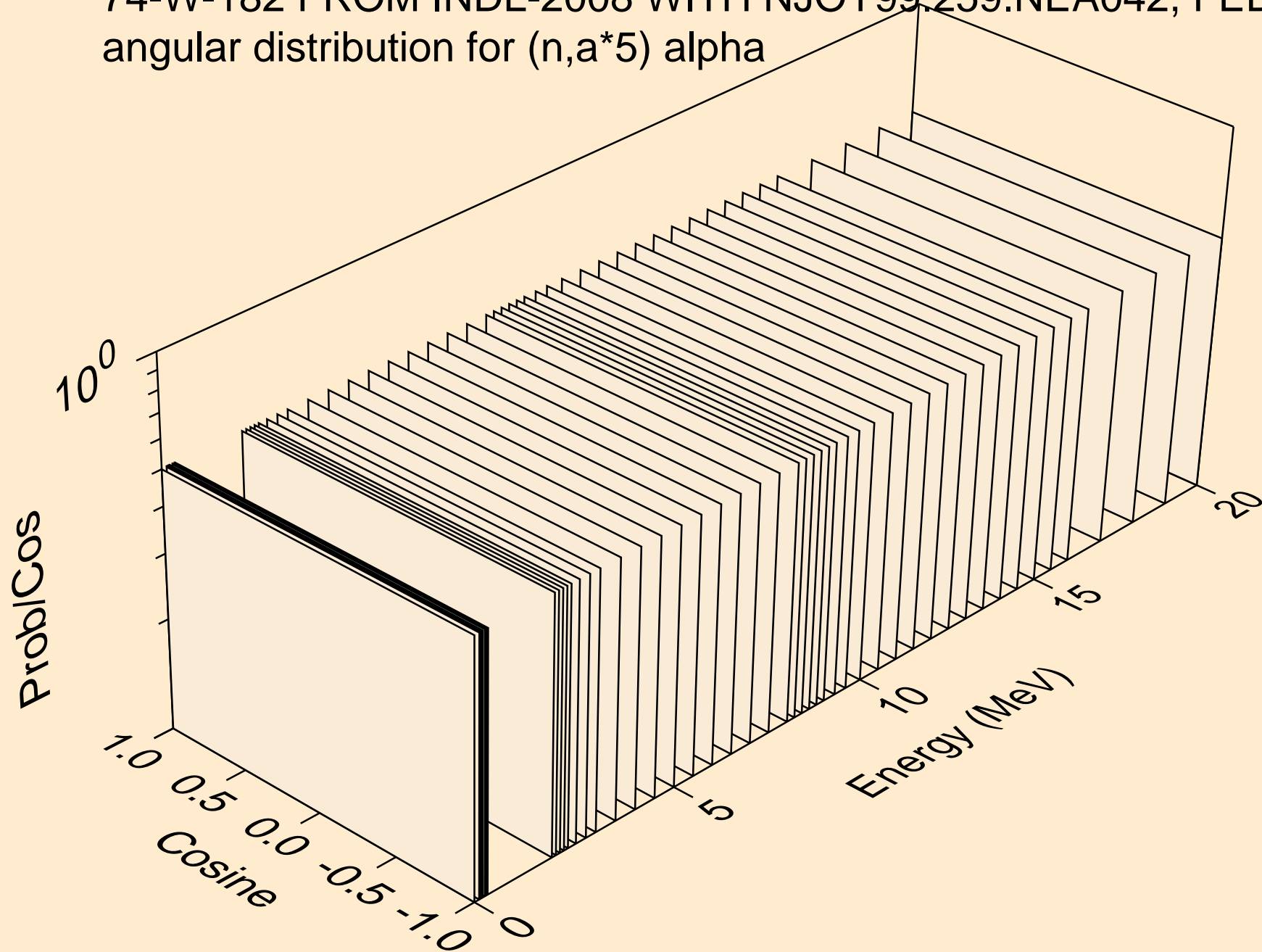

74-W-182 FROM INDL-2008 WITH NJOY99.259.NEA042, FEB. 200
angular distribution for (n,a*5) alpha

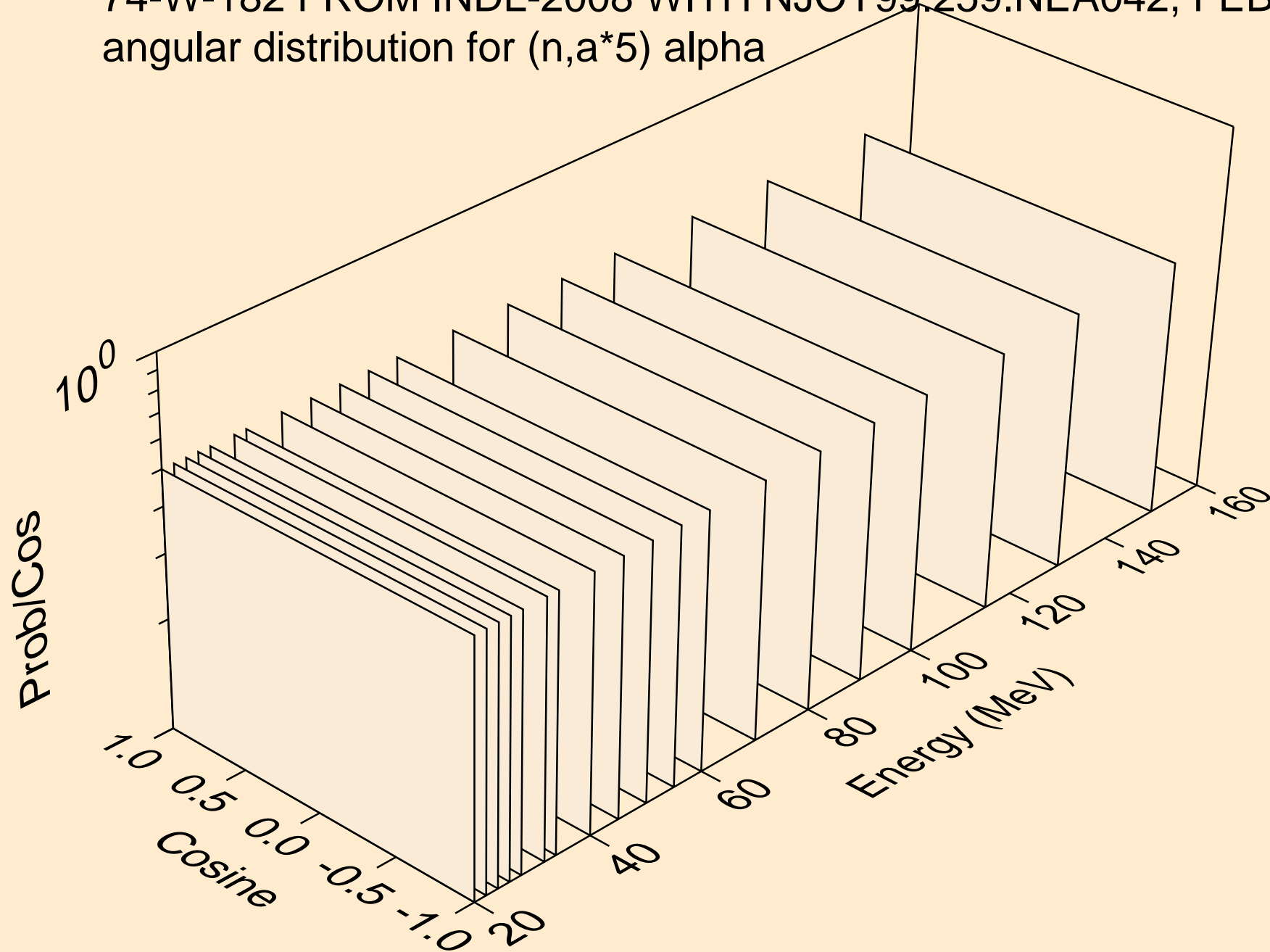

74-W-182 FROM INDL-2008 WITH NJOY99.259.NEA042, FEB. 200
angular distribution for (n,a*6) alpha

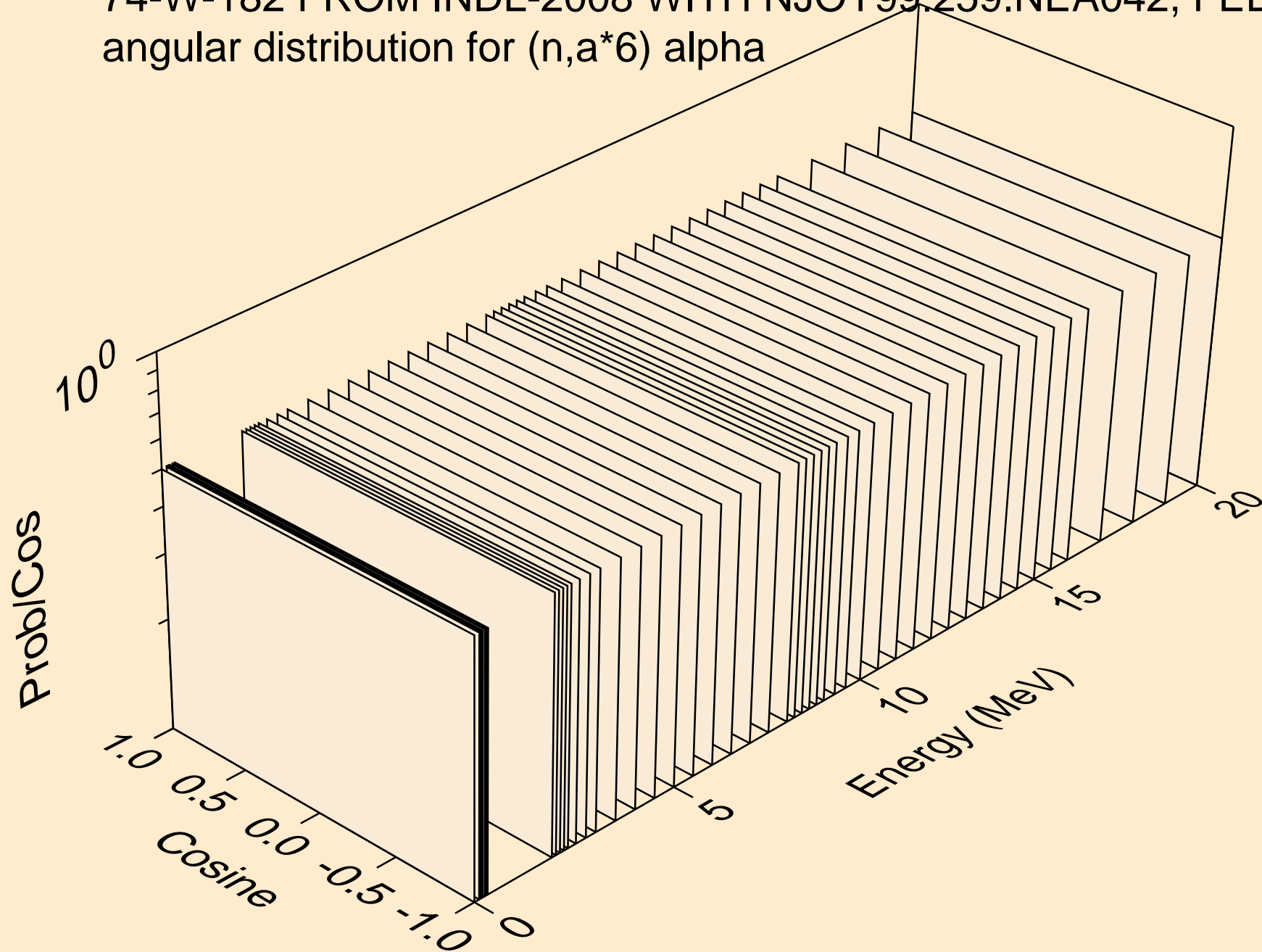

74-W-182 FROM INDL-2008 WITH NJOY99.259.NEA042, FEB. 200
angular distribution for (n,a*6) alpha

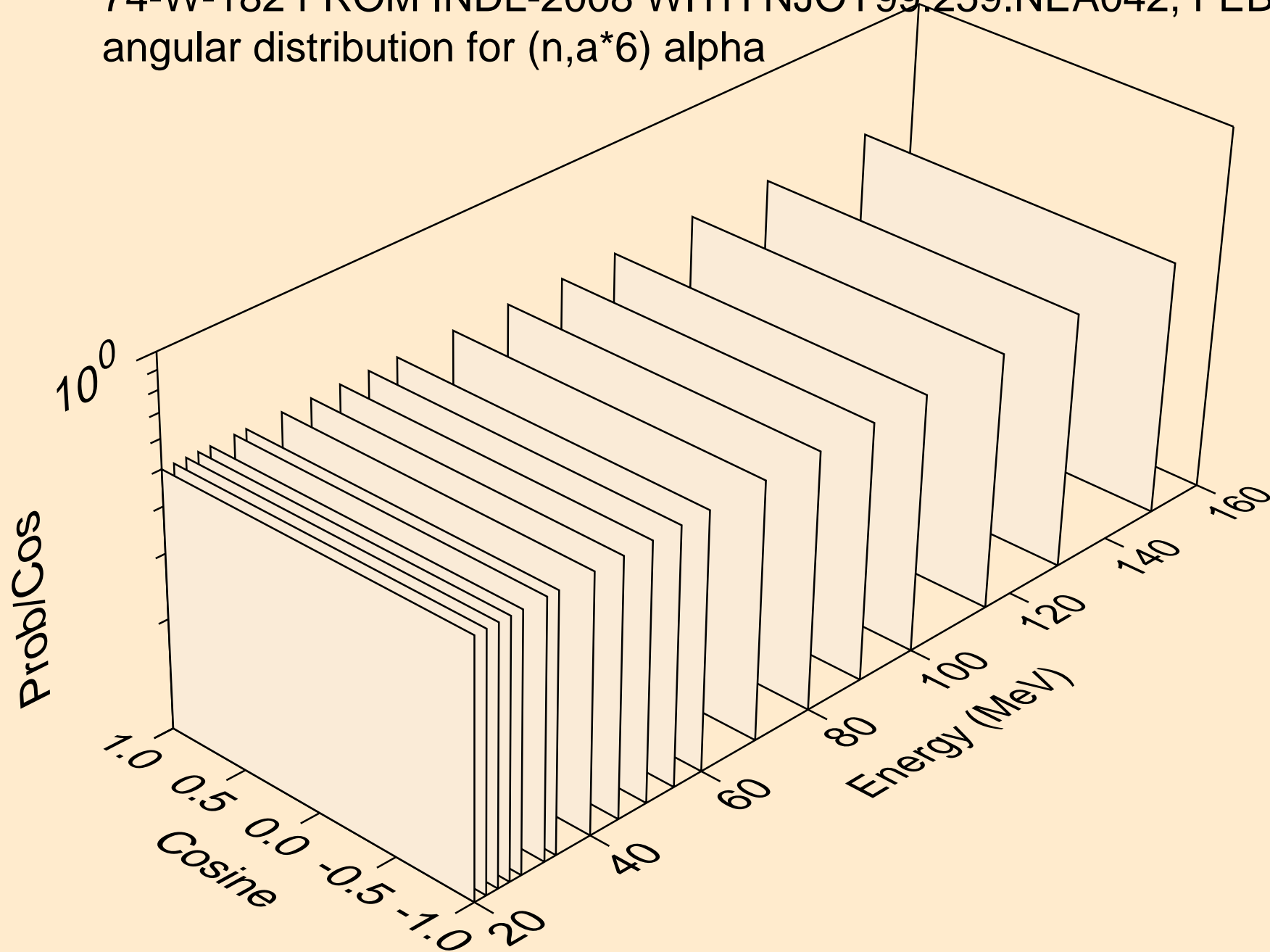

74-W-182 FROM INDL-2008 WITH NJOY99.259.NEA042, FEB. 200
alphas from (n,a*c)

