

74-W-183 FROM INDL-2008 WITH NJOY99.259.NEA042, FEB. 200
Principal cross sections

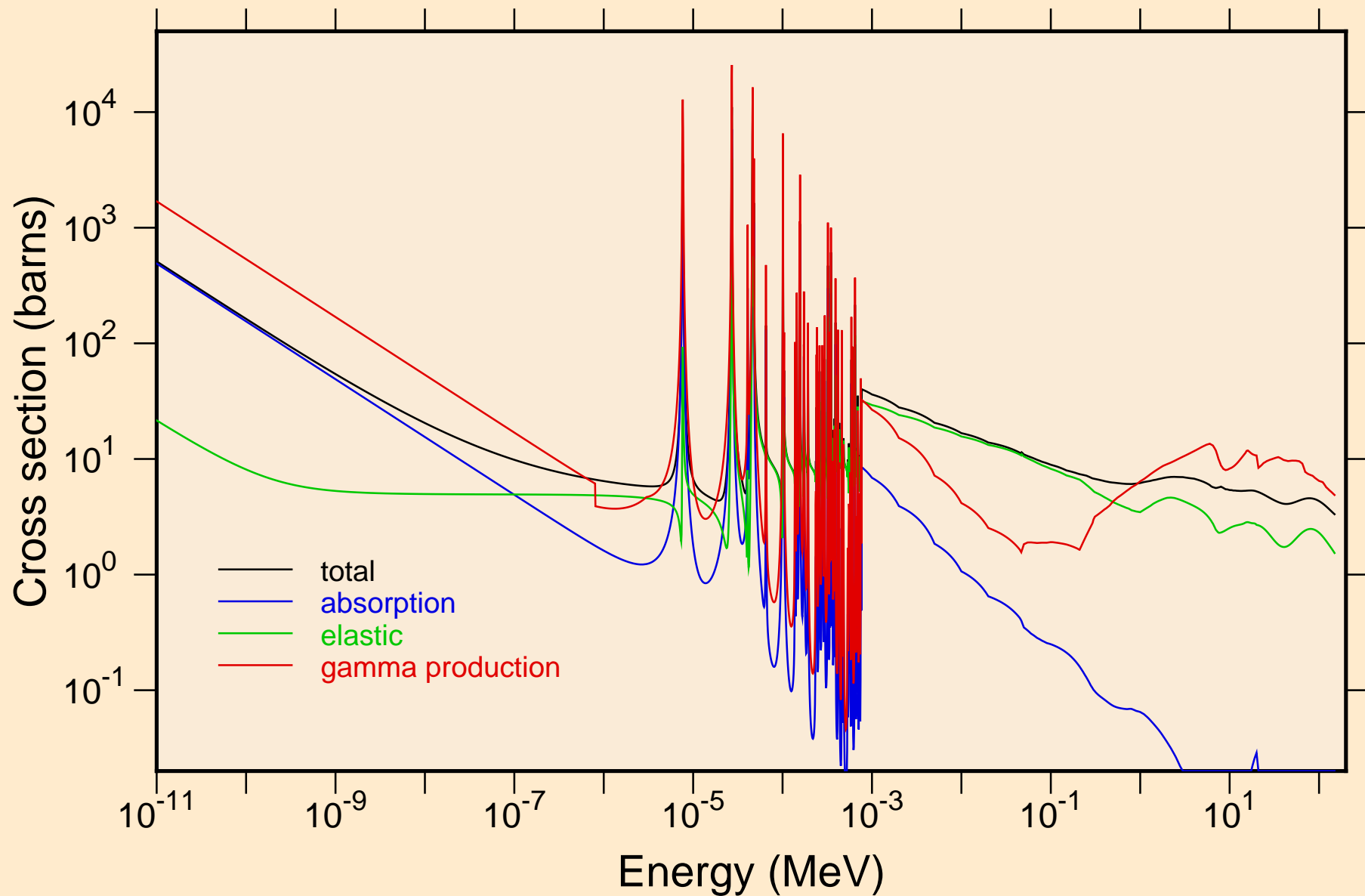

74-W-183 FROM INDL-2008 WITH NJOY99.259.NEA042, FEB. 200
resonance total cross section

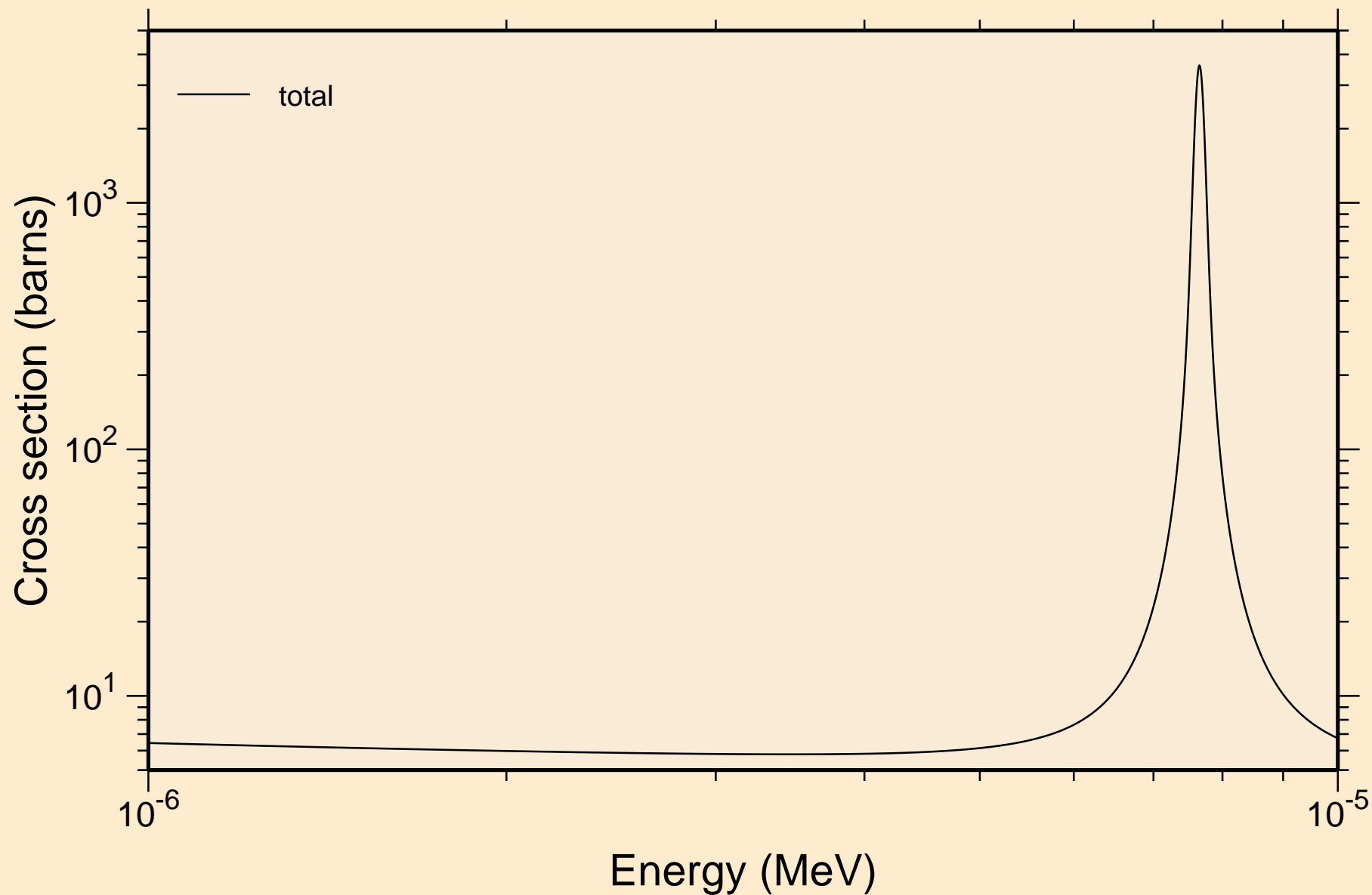

74-W-183 FROM INDL-2008 WITH NJOY99.259.NEA042, FEB. 200
resonance total cross section

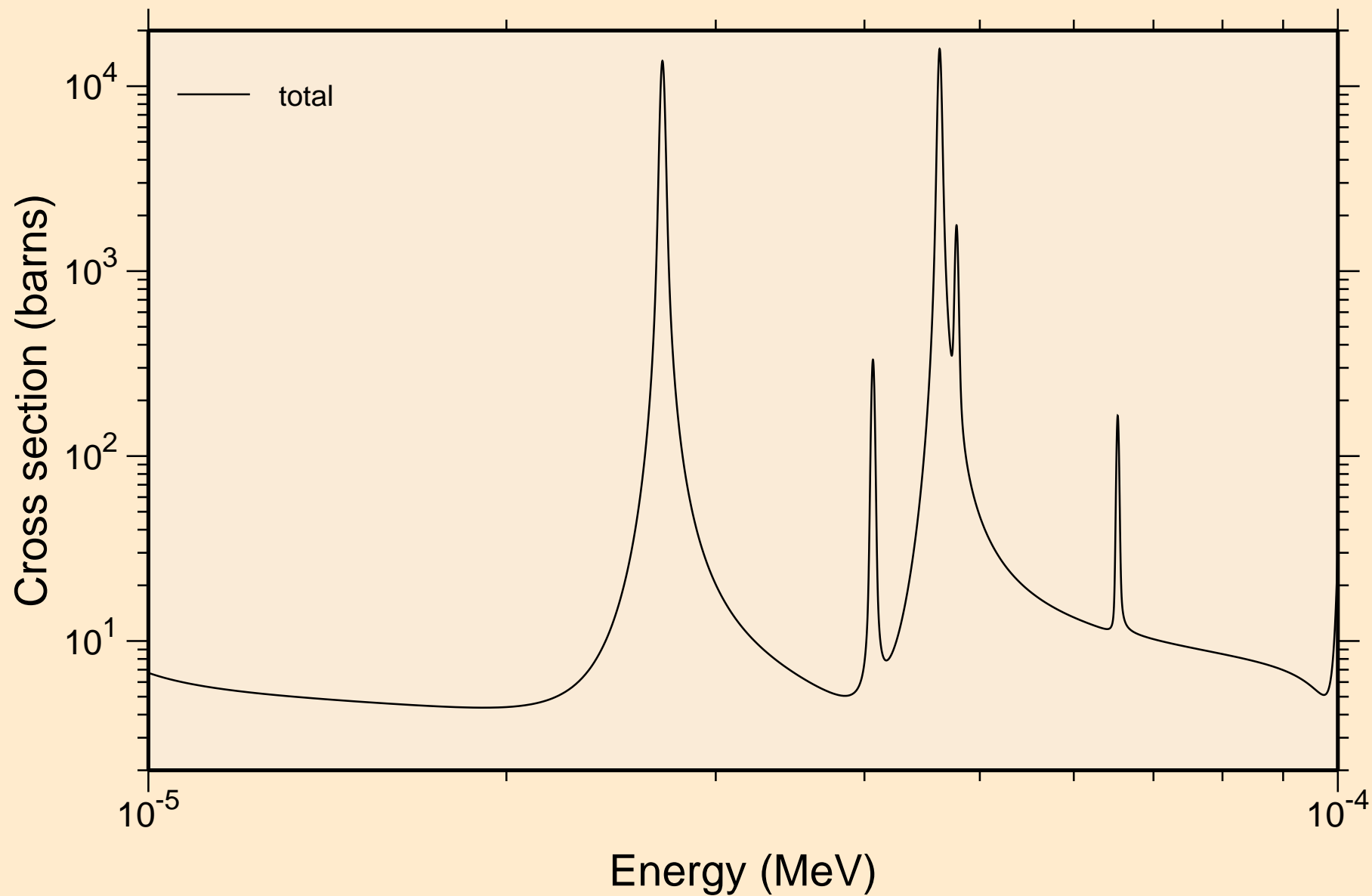

74-W-183 FROM INDL-2008 WITH NJOY99.259.NEA042, FEB. 200
resonance total cross section

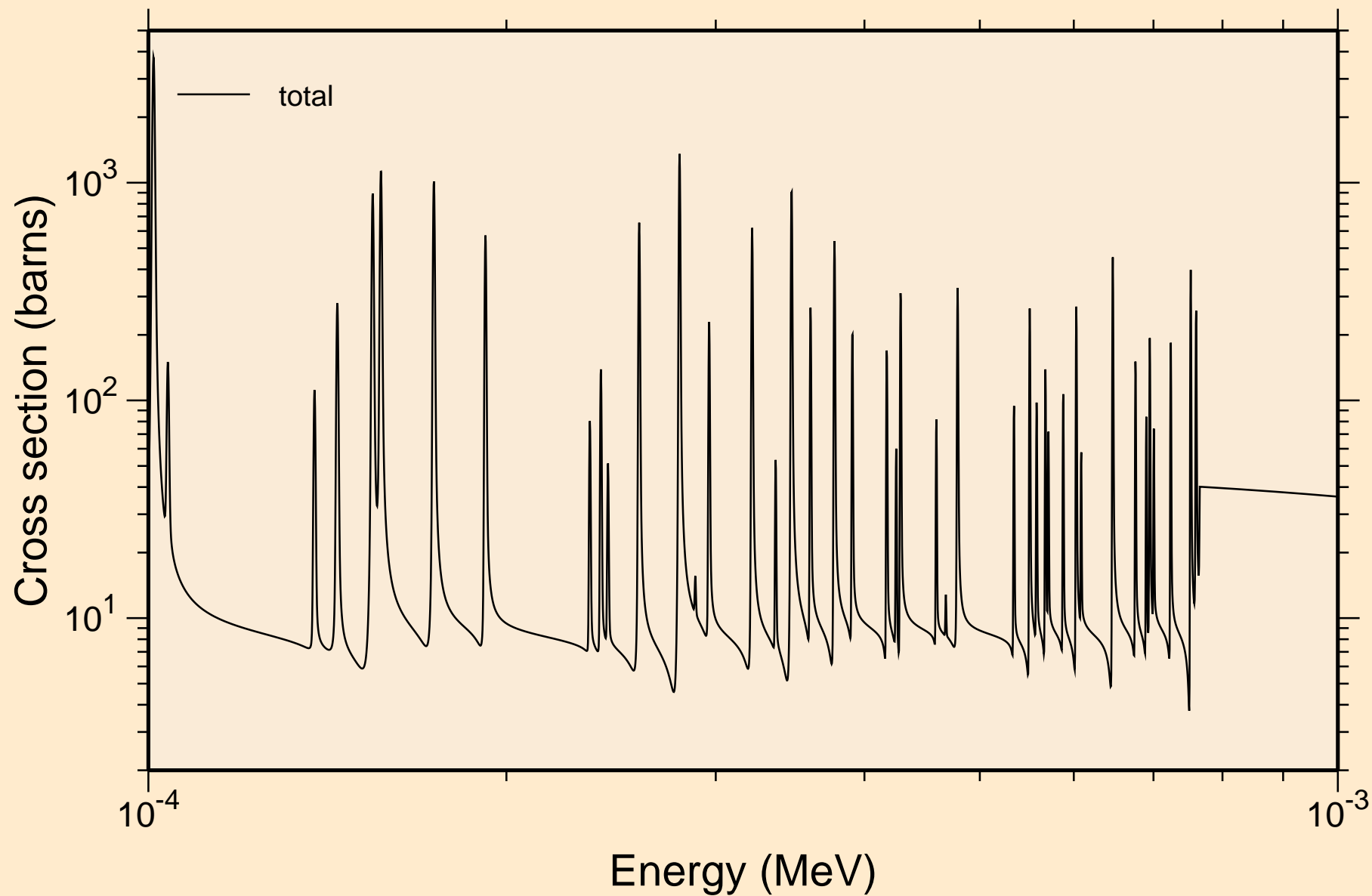

74-W-183 FROM INDL-2008 WITH NJOY99.259.NEA042, FEB. 200
resonance total cross section

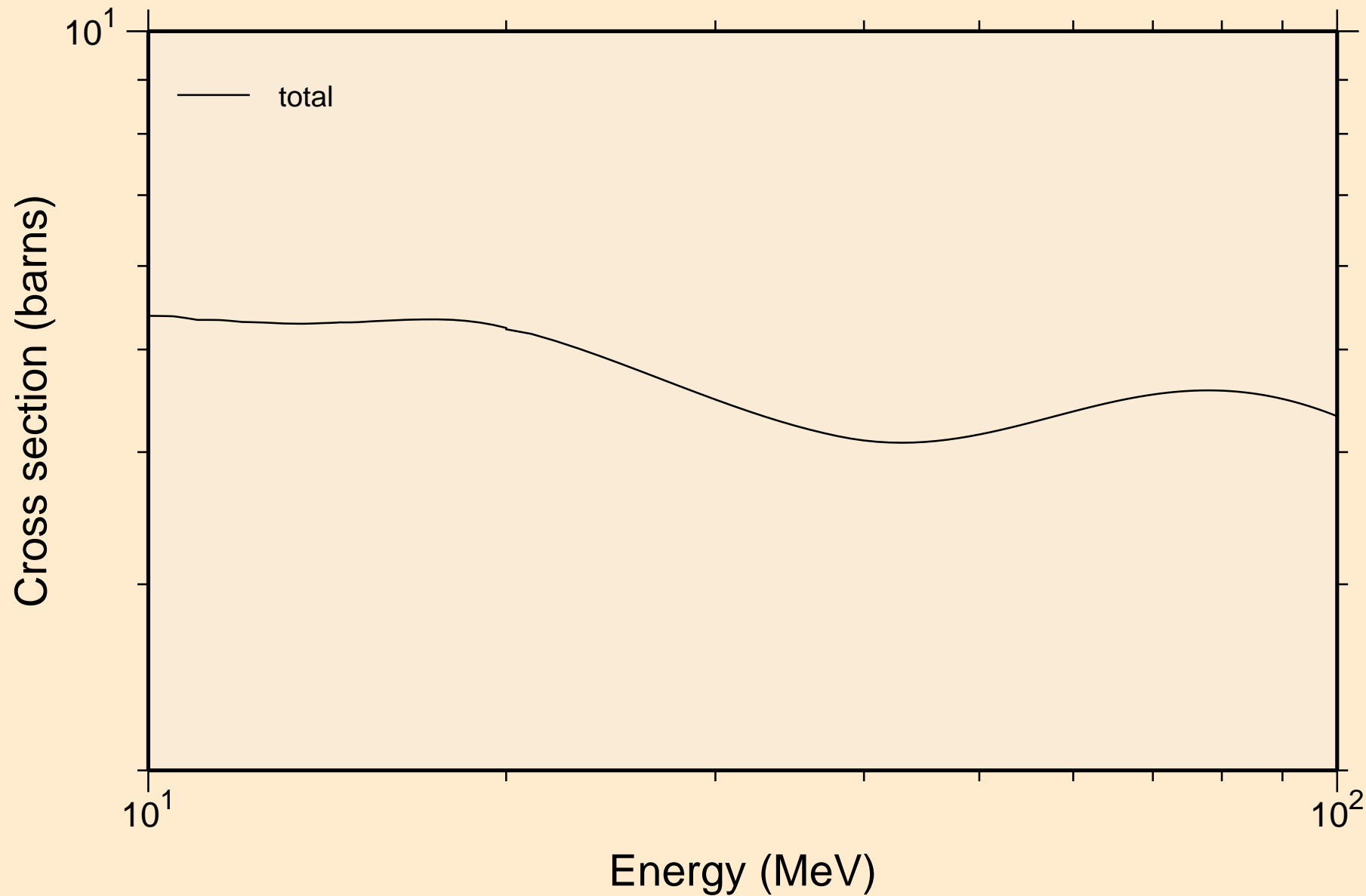

74-W-183 FROM INDL-2008 WITH NJOY99.259.NEA042, FEB. 200
resonance absorption cross sections

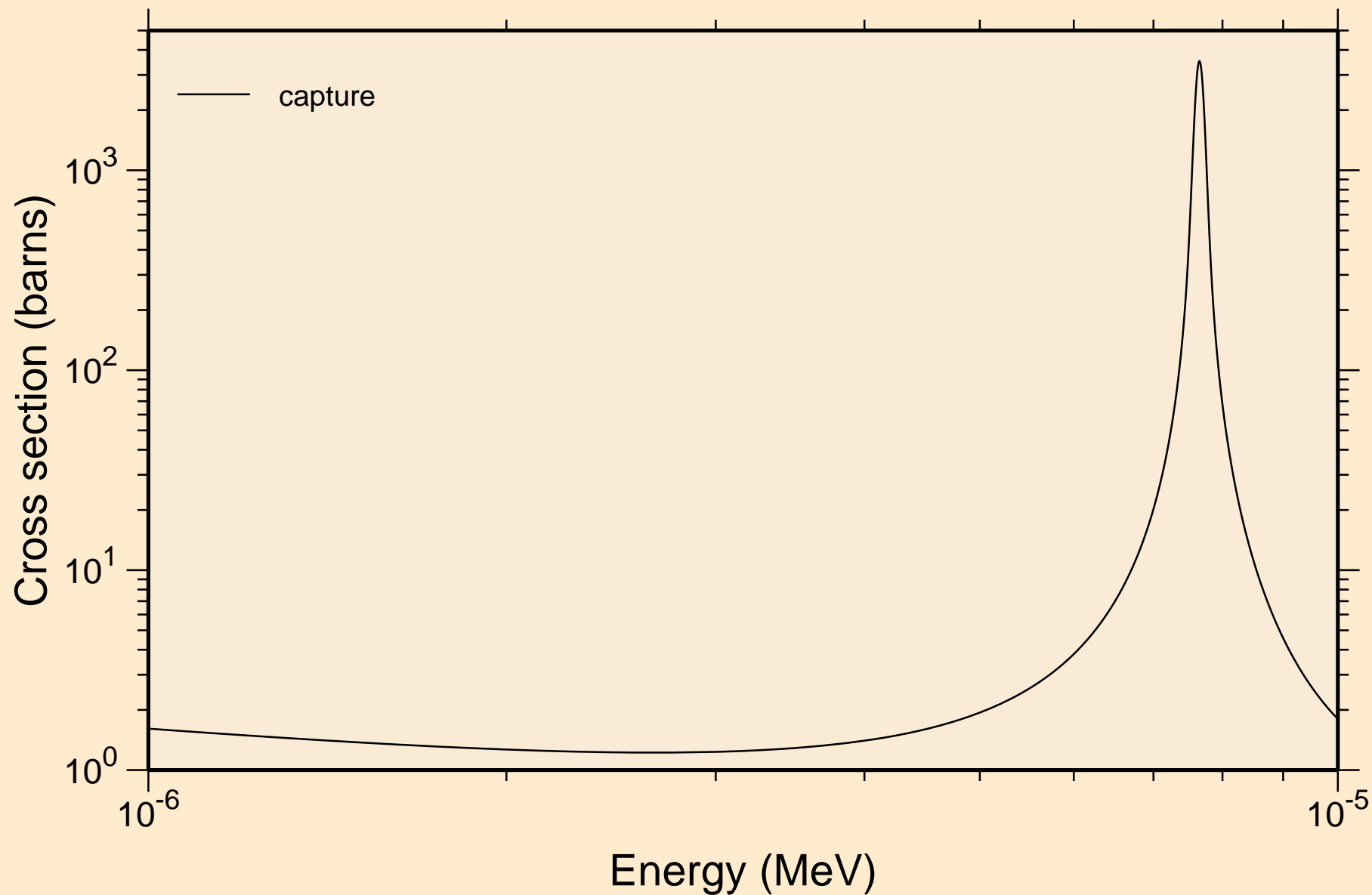

74-W-183 FROM INDL-2008 WITH NJOY99.259.NEA042, FEB. 200
resonance absorption cross sections

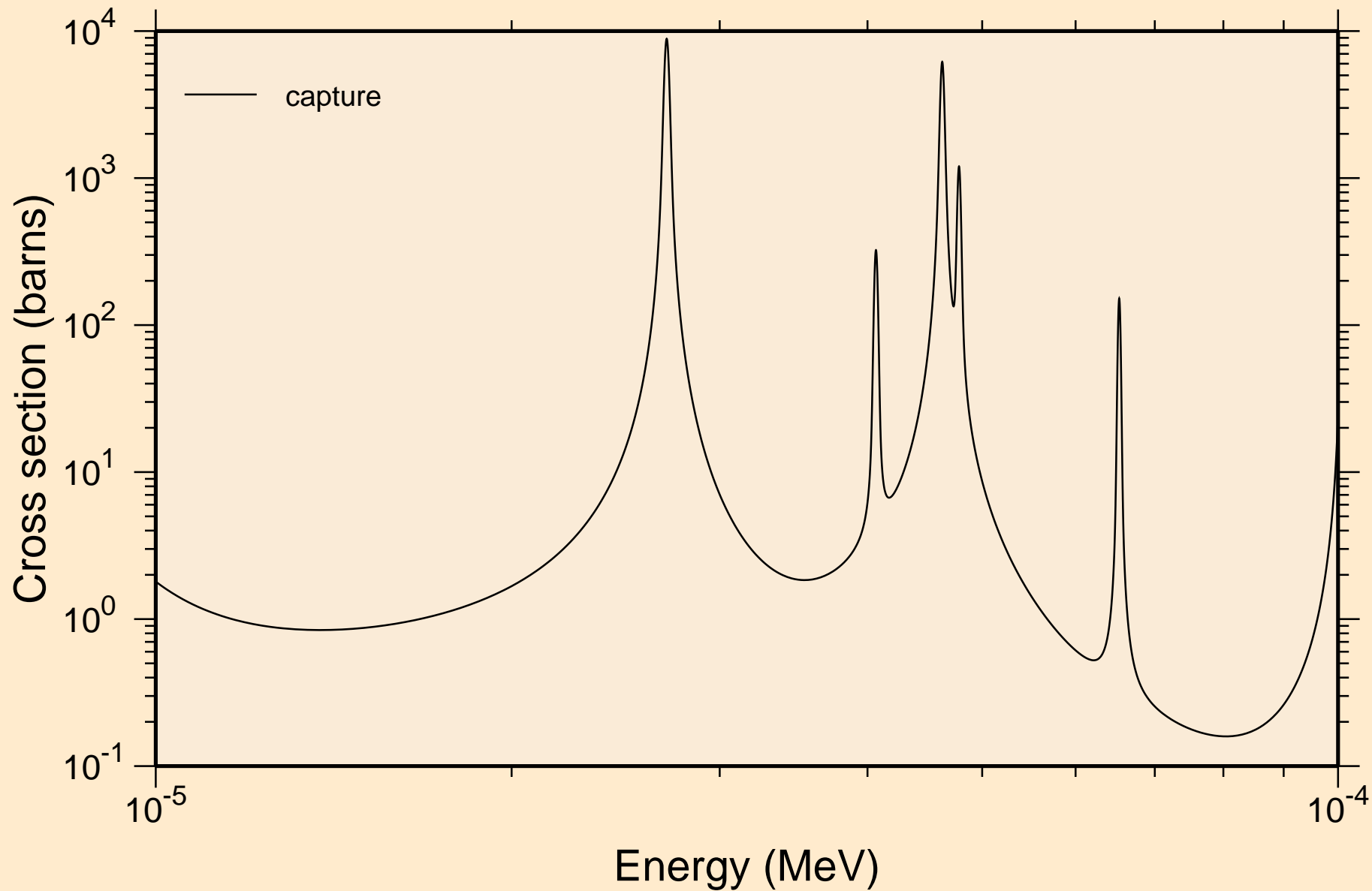

74-W-183 FROM INDL-2008 WITH NJOY99.259.NEA042, FEB. 200
resonance absorption cross sections

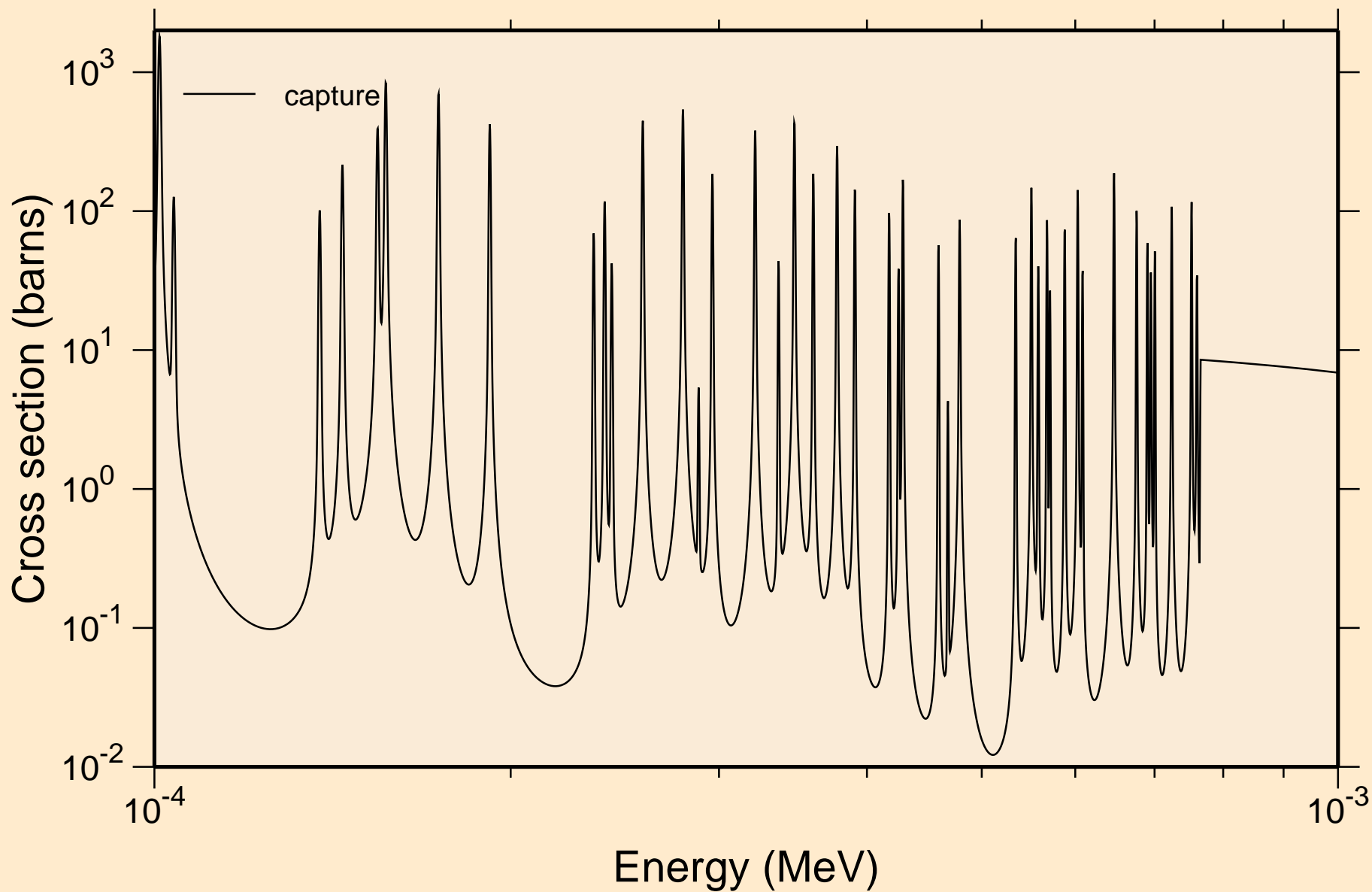

74-W-183 FROM INDL-2008 WITH NJOY99.259.NEA042, FEB. 200
resonance absorption cross sections

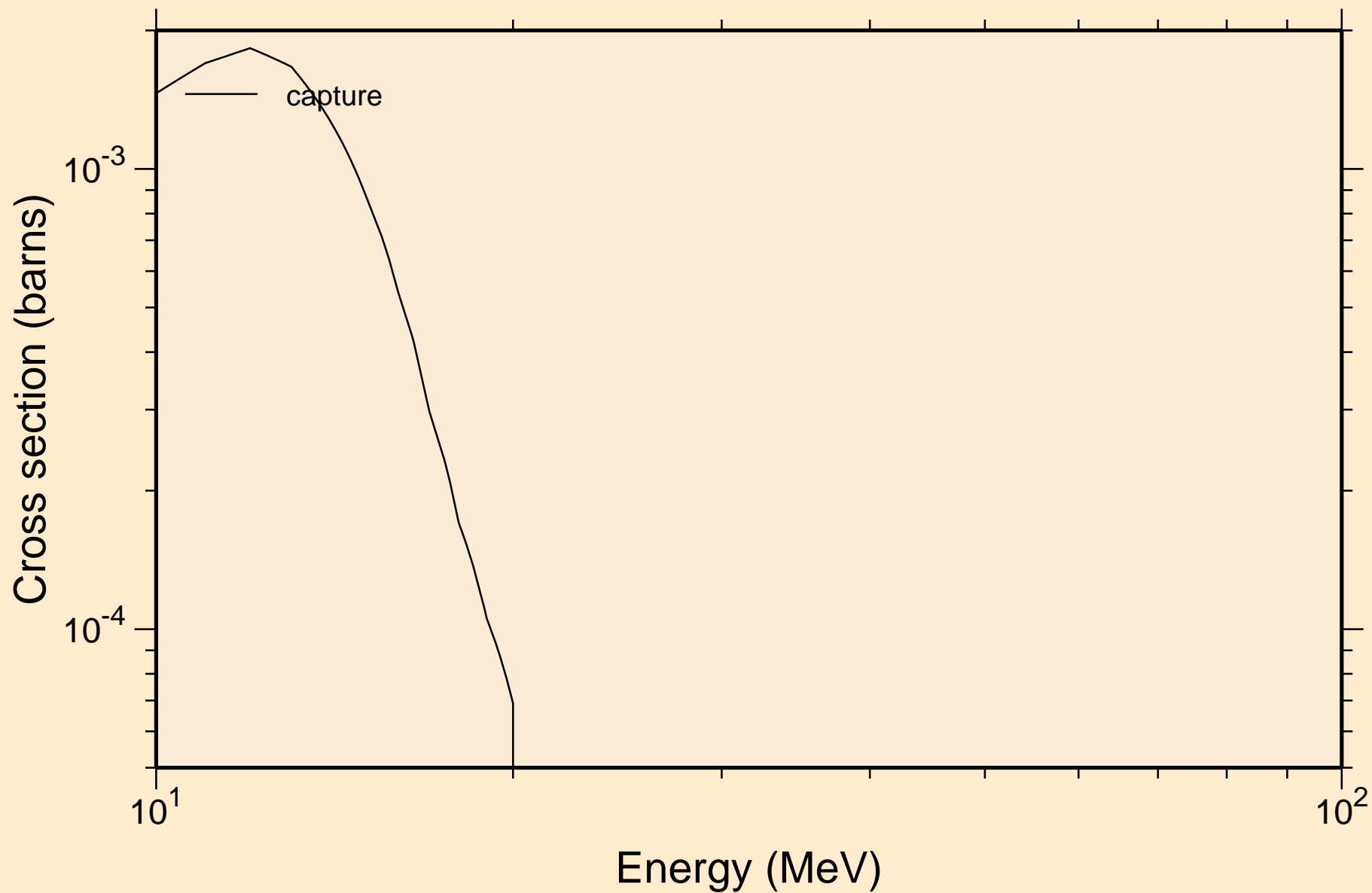

74-W-183 FROM INDL-2008 WITH NJOY99.259.NEA042, FEB. 200 Heating

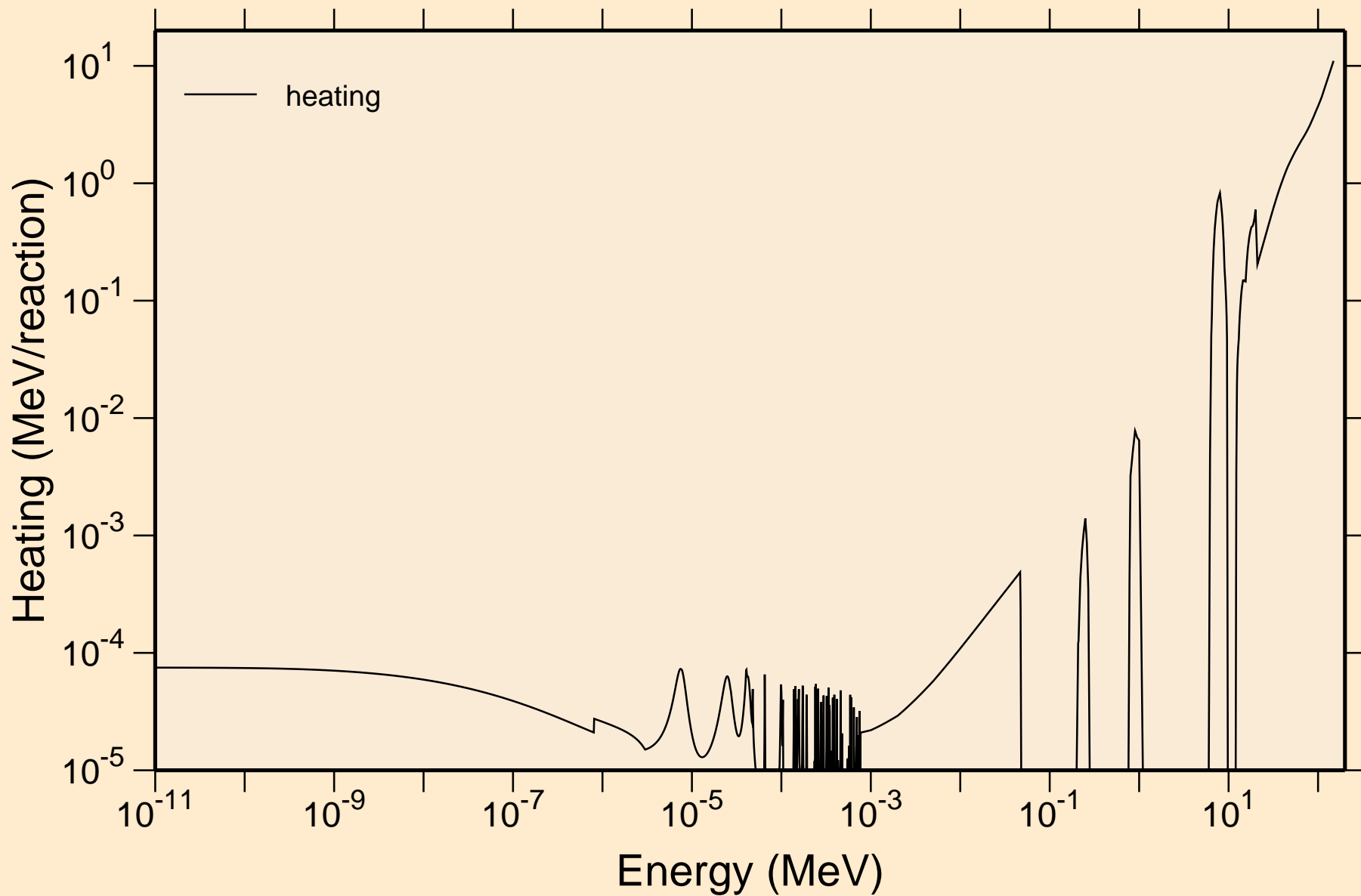

74-W-183 FROM INDL-2008 WITH NJOY99.259.NEA042, FEB. 200
Damage

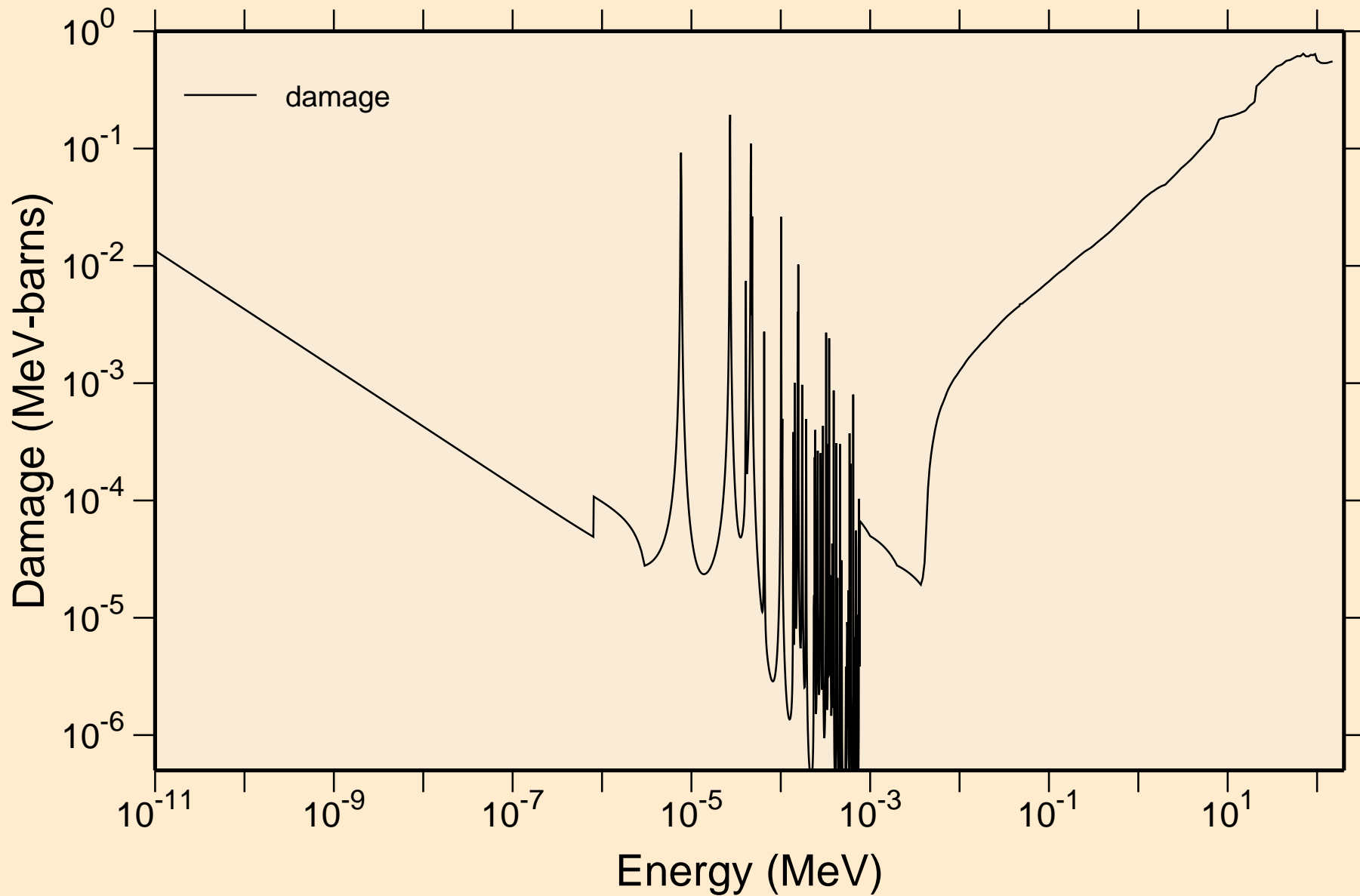

74-W-183 FROM INDL-2008 WITH NJOY99.259.NEA042, FEB. 200
Non-threshold reactions

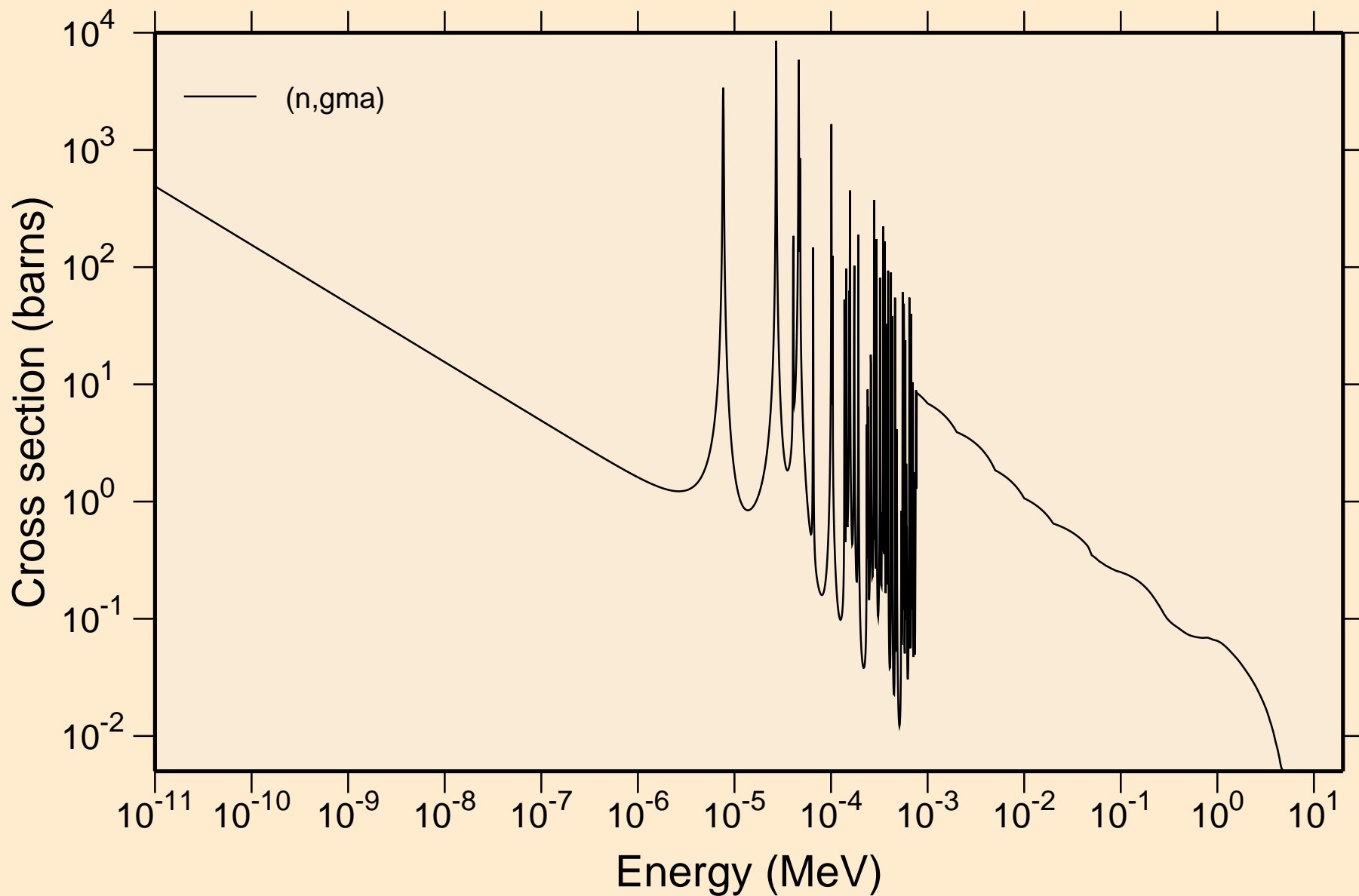

74-W-183 FROM INDL-2008 WITH NJOY99.259.NEA042, FEB. 200
Principal cross sections

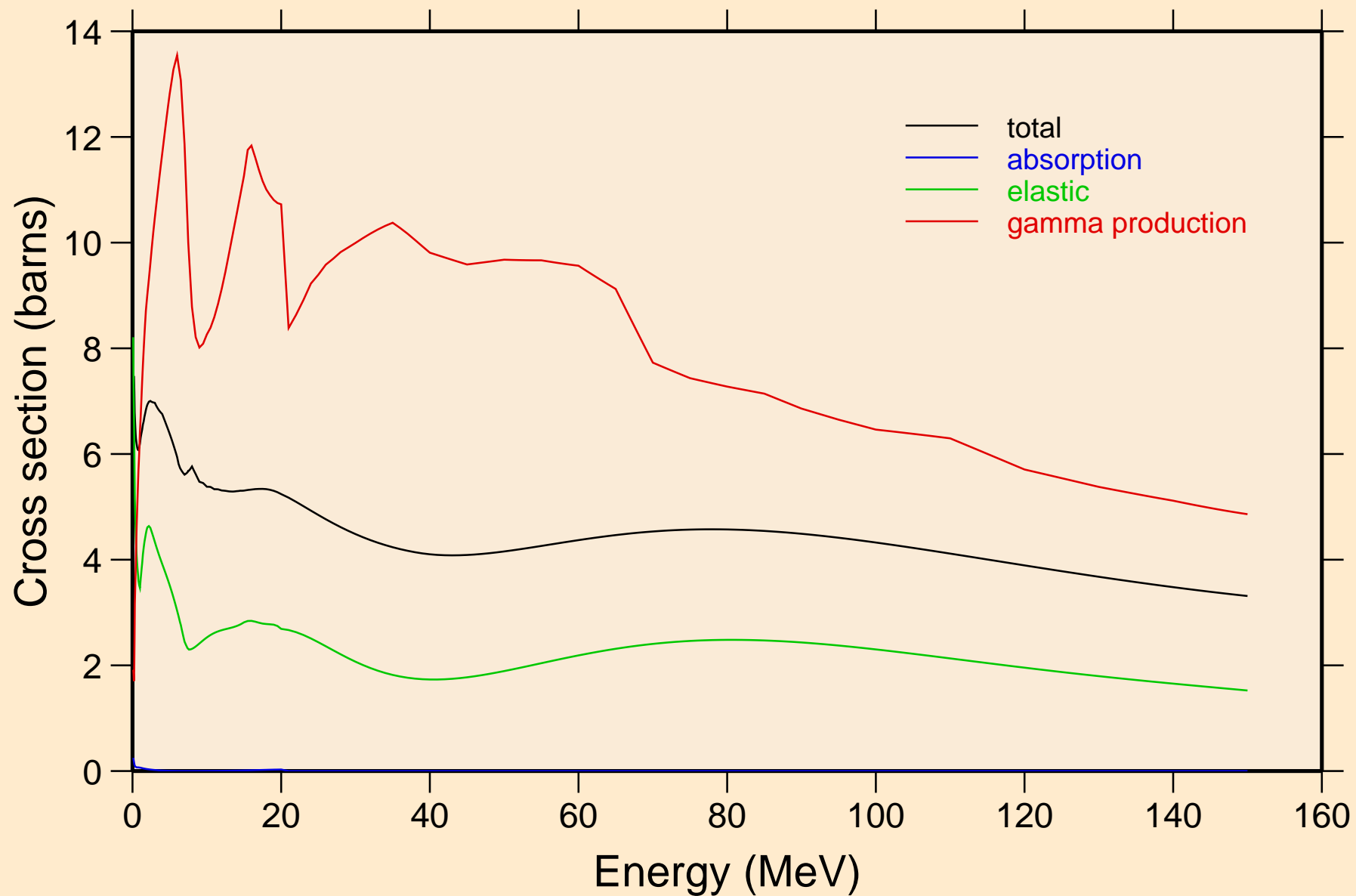

74-W-183 FROM INDL-2008 WITH NJOY99.259.NEA042, FEB. 200
Heating

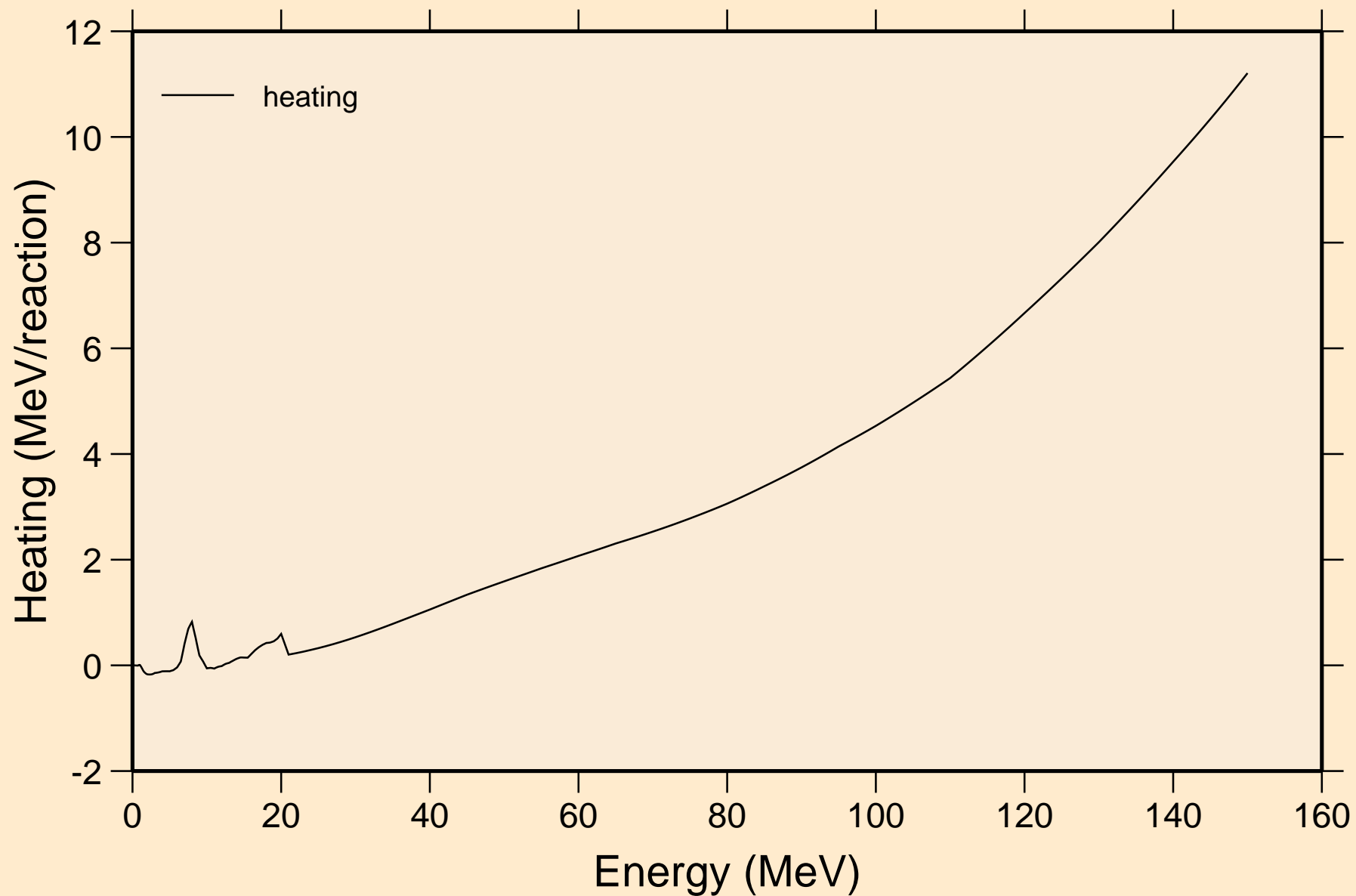

74-W-183 FROM INDL-2008 WITH NJOY99.259.NEA042, FEB. 200

Damage

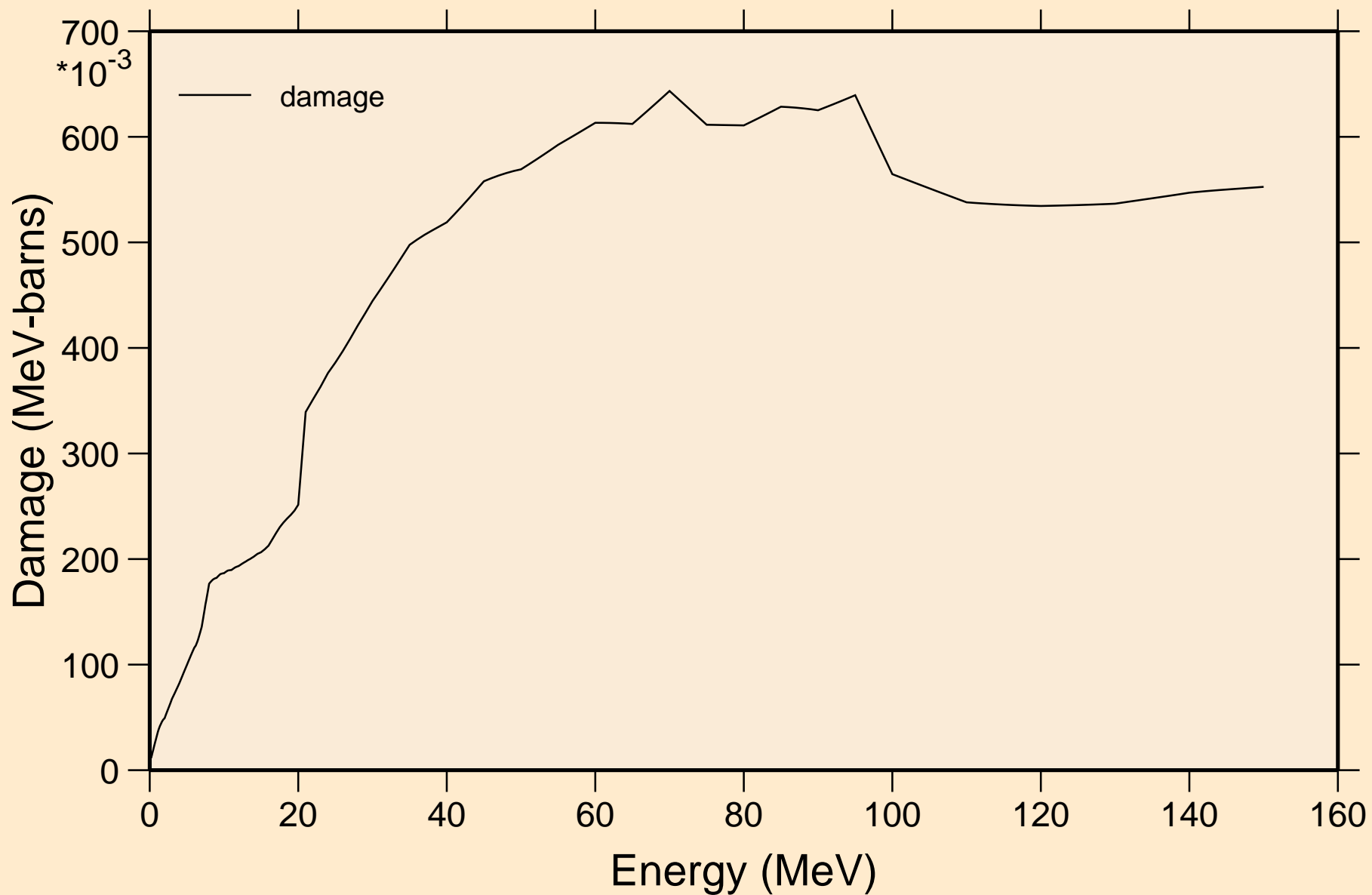

74-W-183 FROM INDL-2008 WITH NJOY99.259.NEA042, FEB. 200
Non-threshold reactions

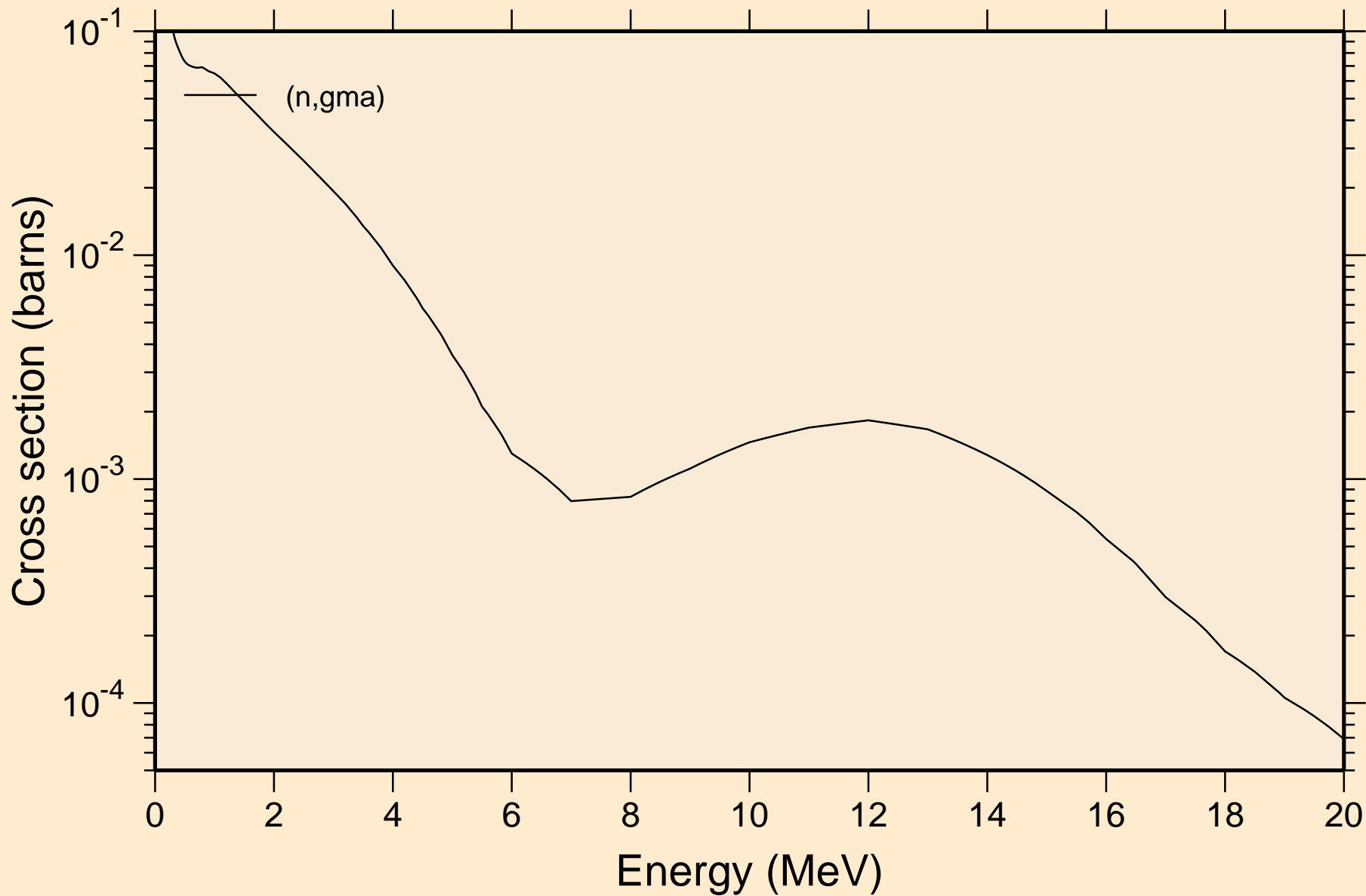

74-W-183 FROM INDL-2008 WITH NJOY99.259.NEA042, FEB. 200
Inelastic levels

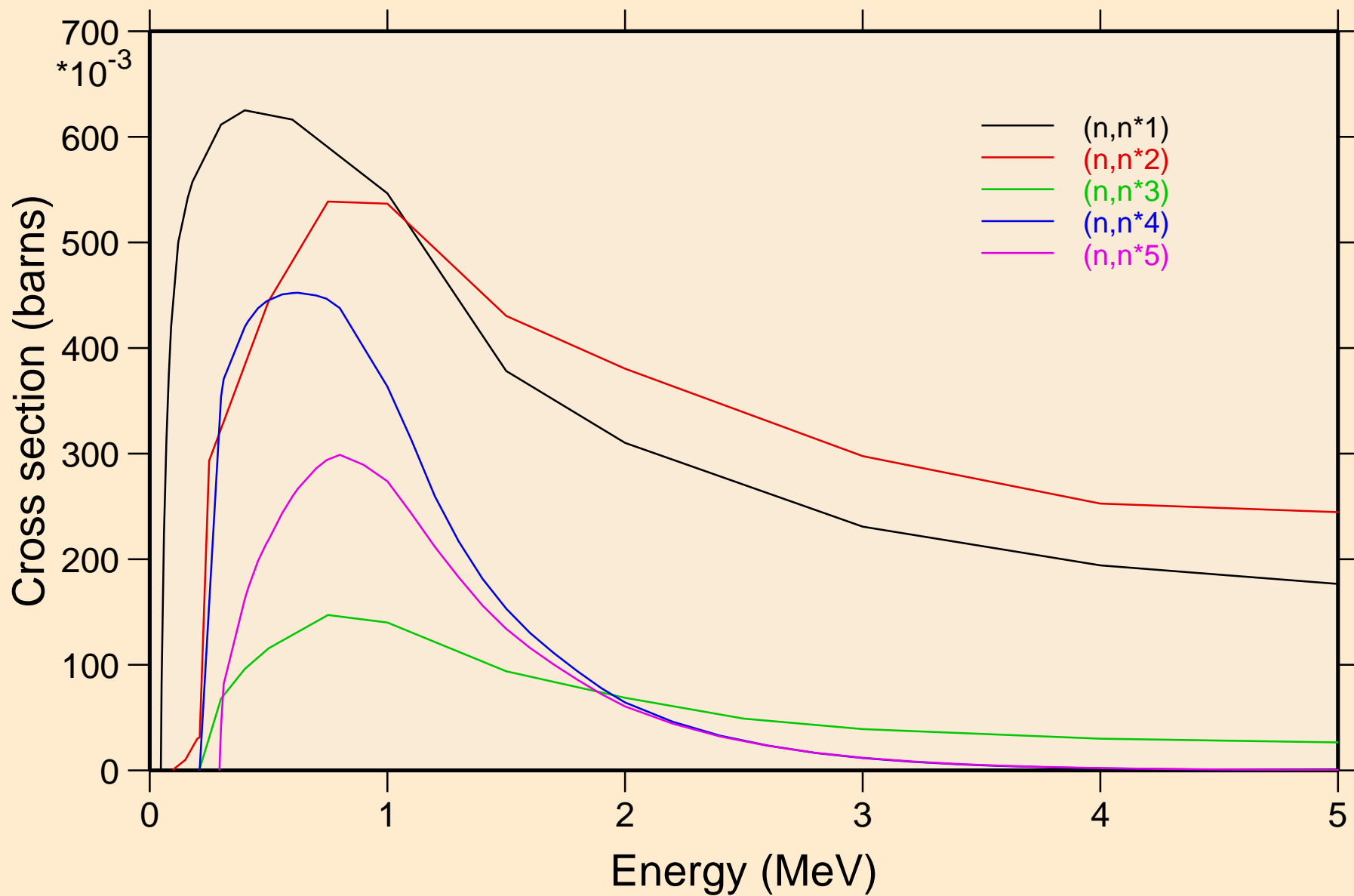

74-W-183 FROM INDL-2008 WITH NJOY99.259.NEA042, FEB. 200
Inelastic levels

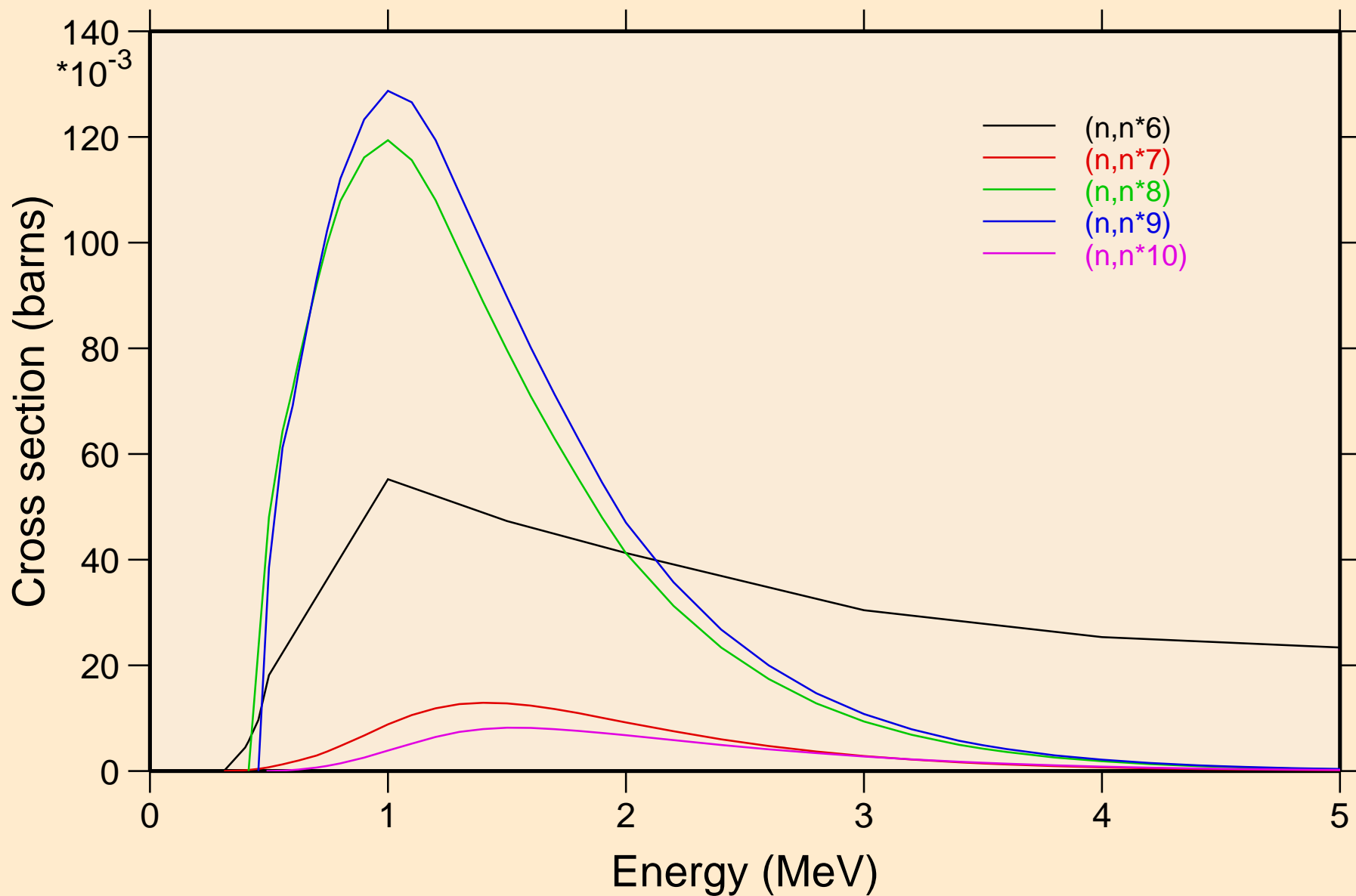

74-W-183 FROM INDL-2008 WITH NJOY99.259.NEA042, FEB. 200
Inelastic levels

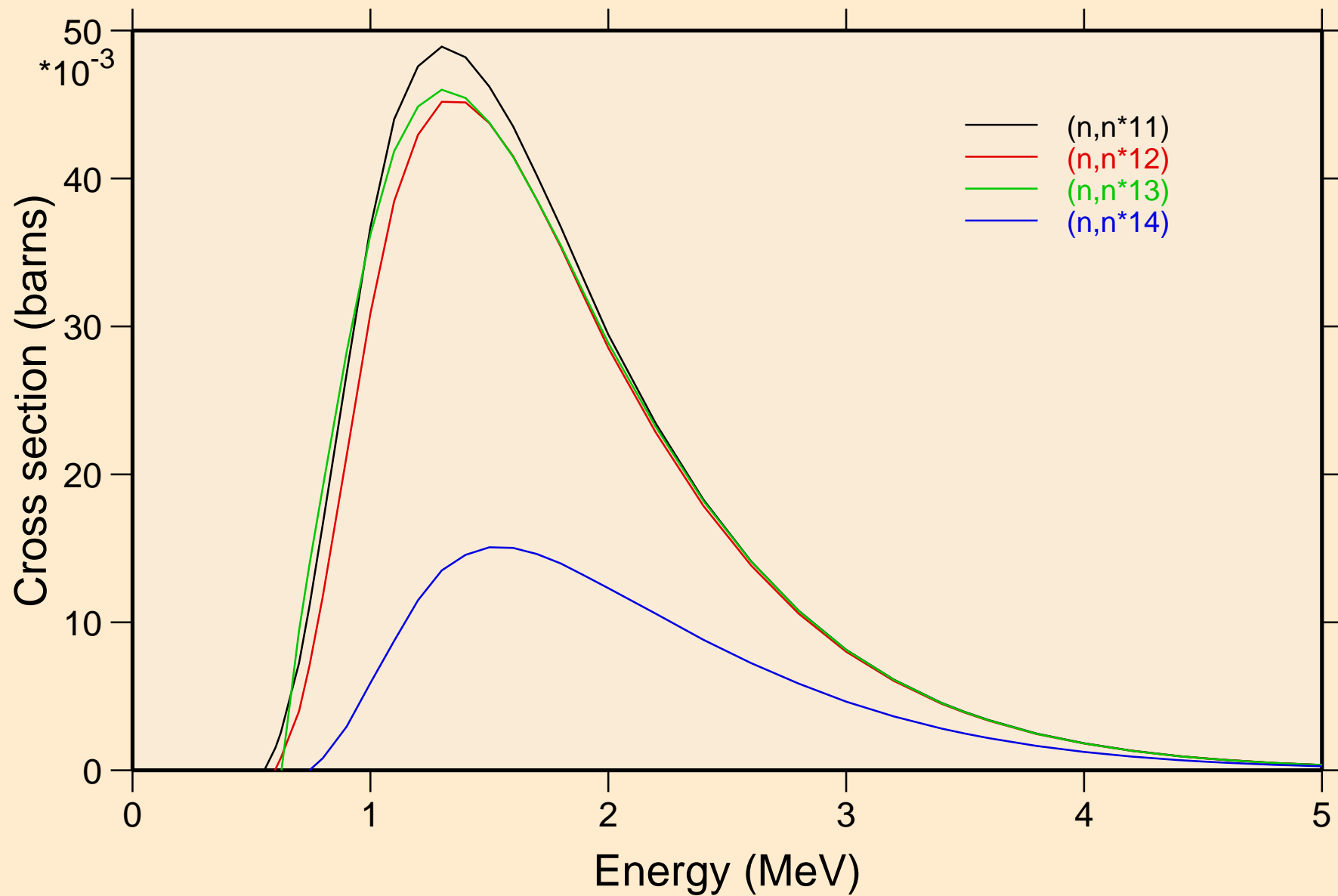

74-W-183 FROM INDL-2008 WITH NJOY99.259.NEA042, FEB. 200
Threshold reactions

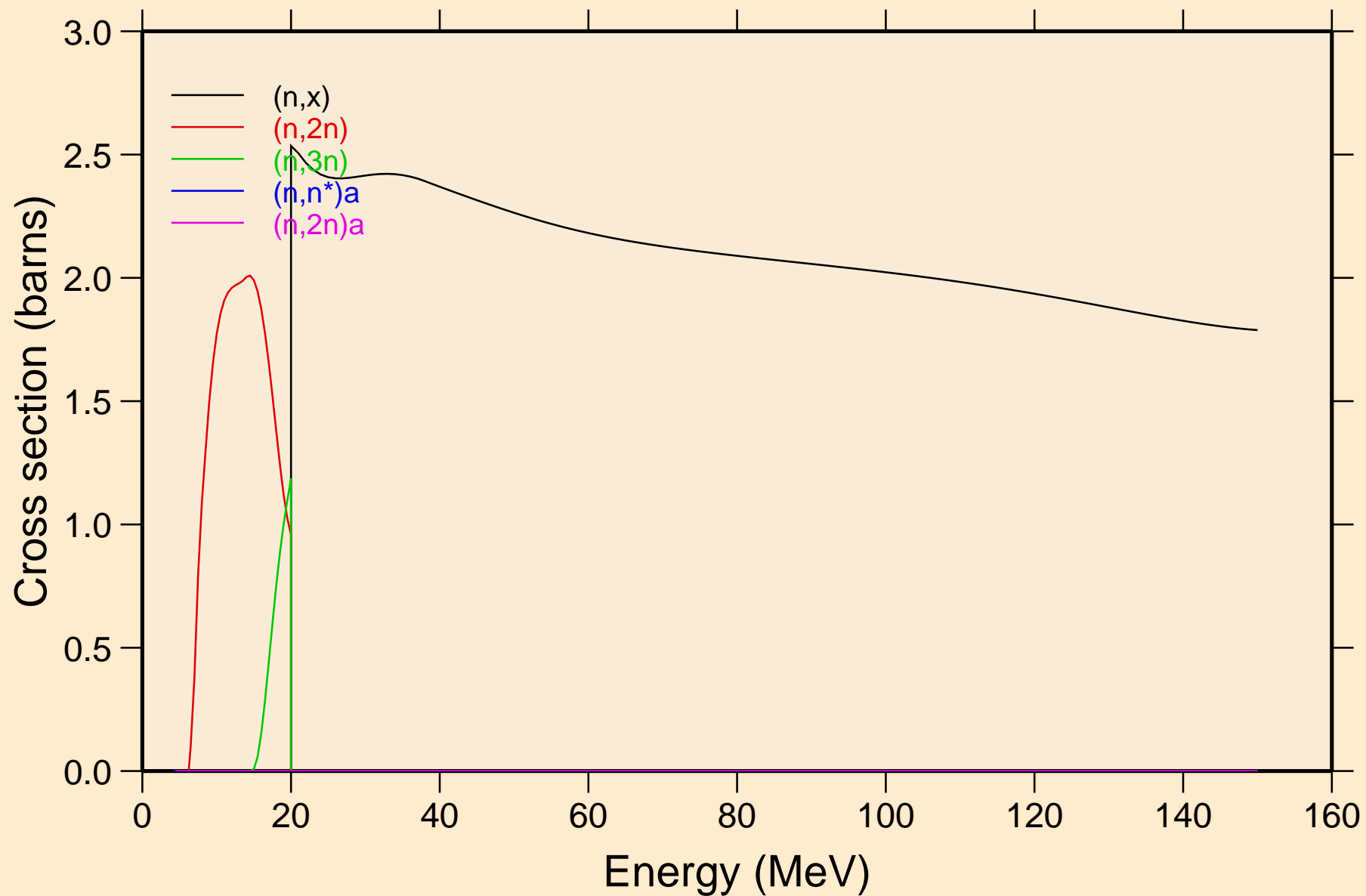

74-W-183 FROM INDL-2008 WITH NJOY99.259.NEA042, FEB. 200
Threshold reactions

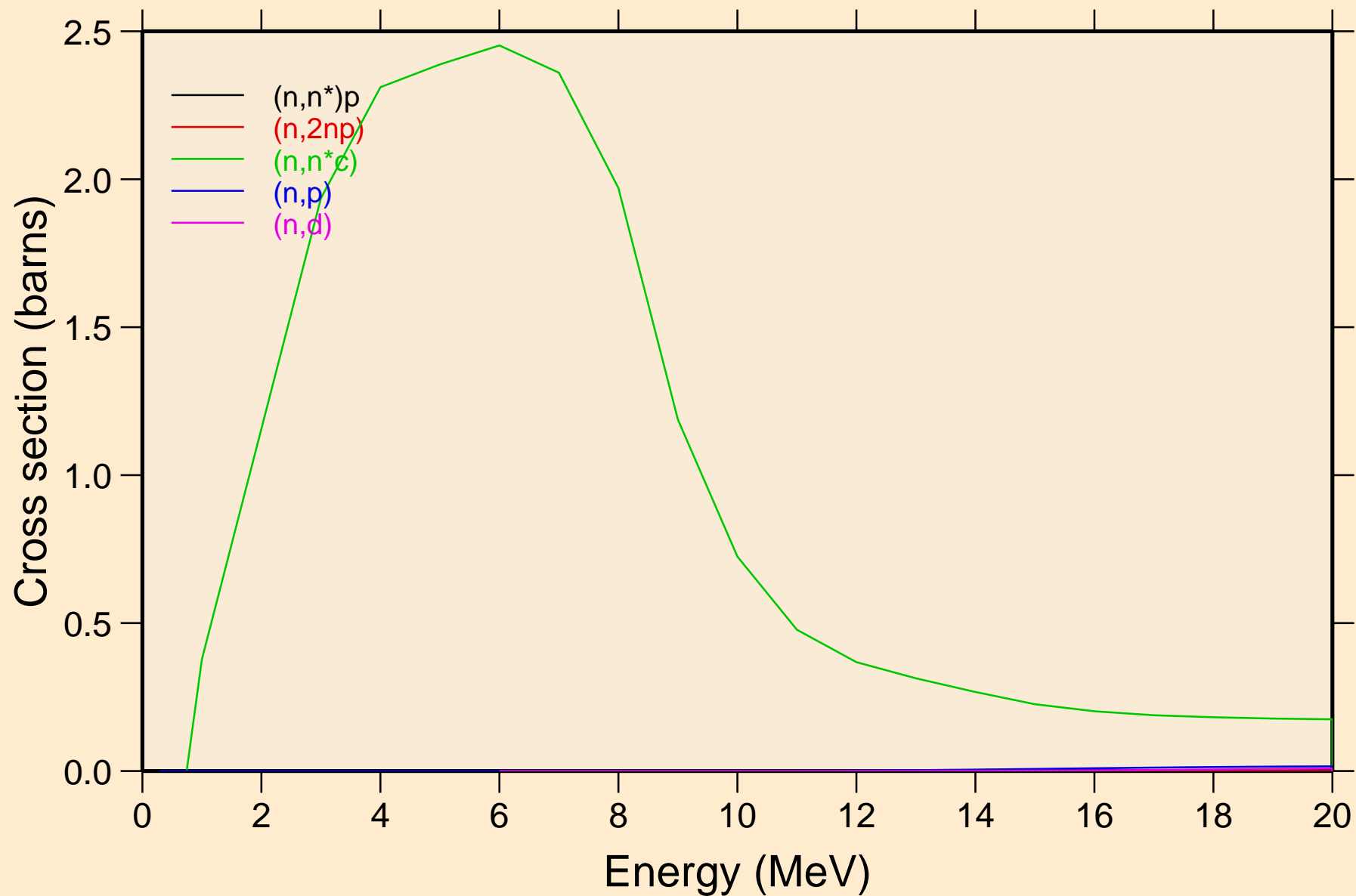

74-W-183 FROM INDL-2008 WITH NJOY99.259.NEA042, FEB. 200
Threshold reactions

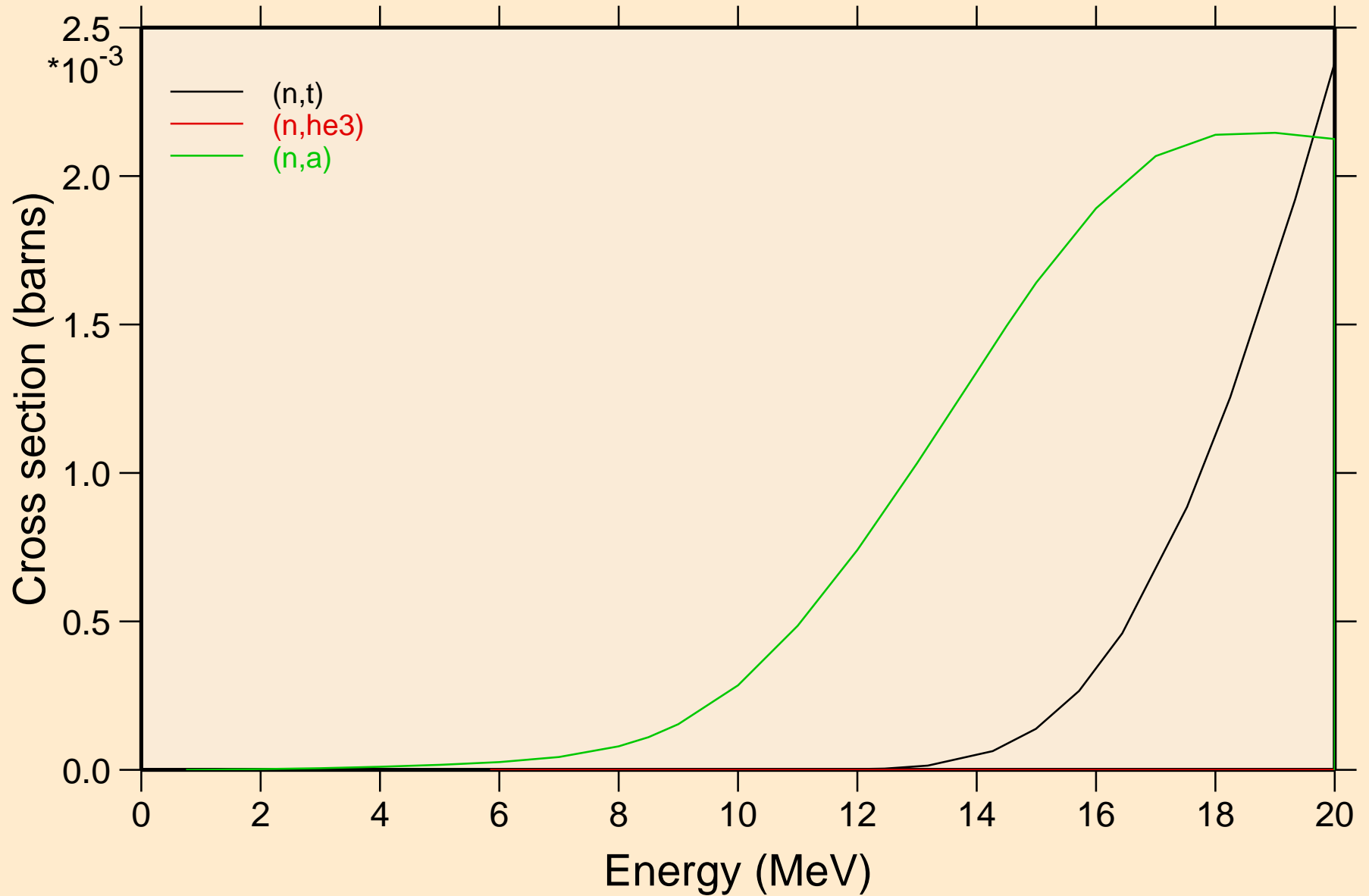

74-W-183 FROM INDL-2008 WITH NJOY99.259.NEA042, FEB. 200
Threshold reactions

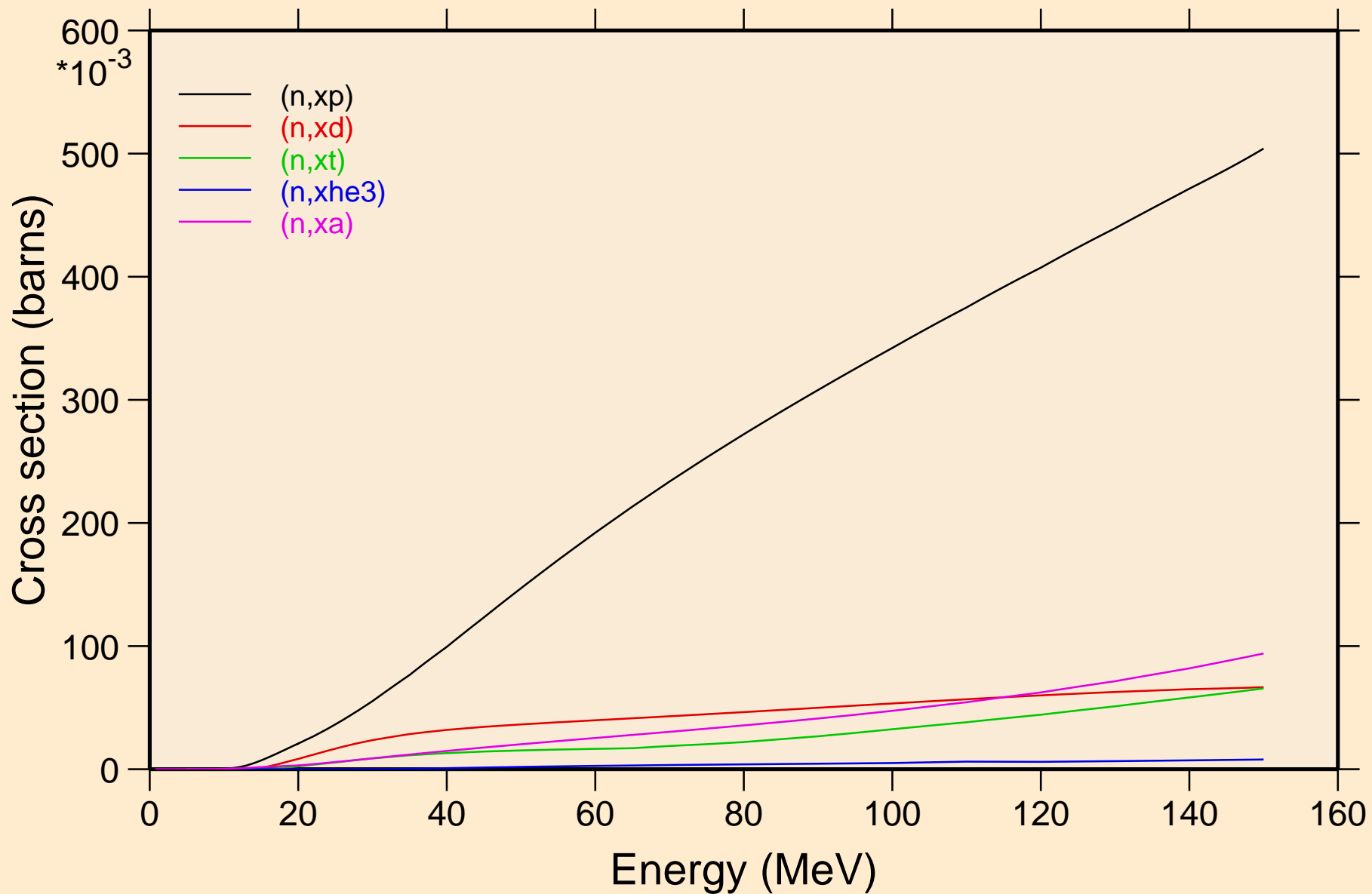

74-W-183 FROM INDL-2008 WITH NJOY99.259.NEA042, FEB. 200
angular distribution for elastic

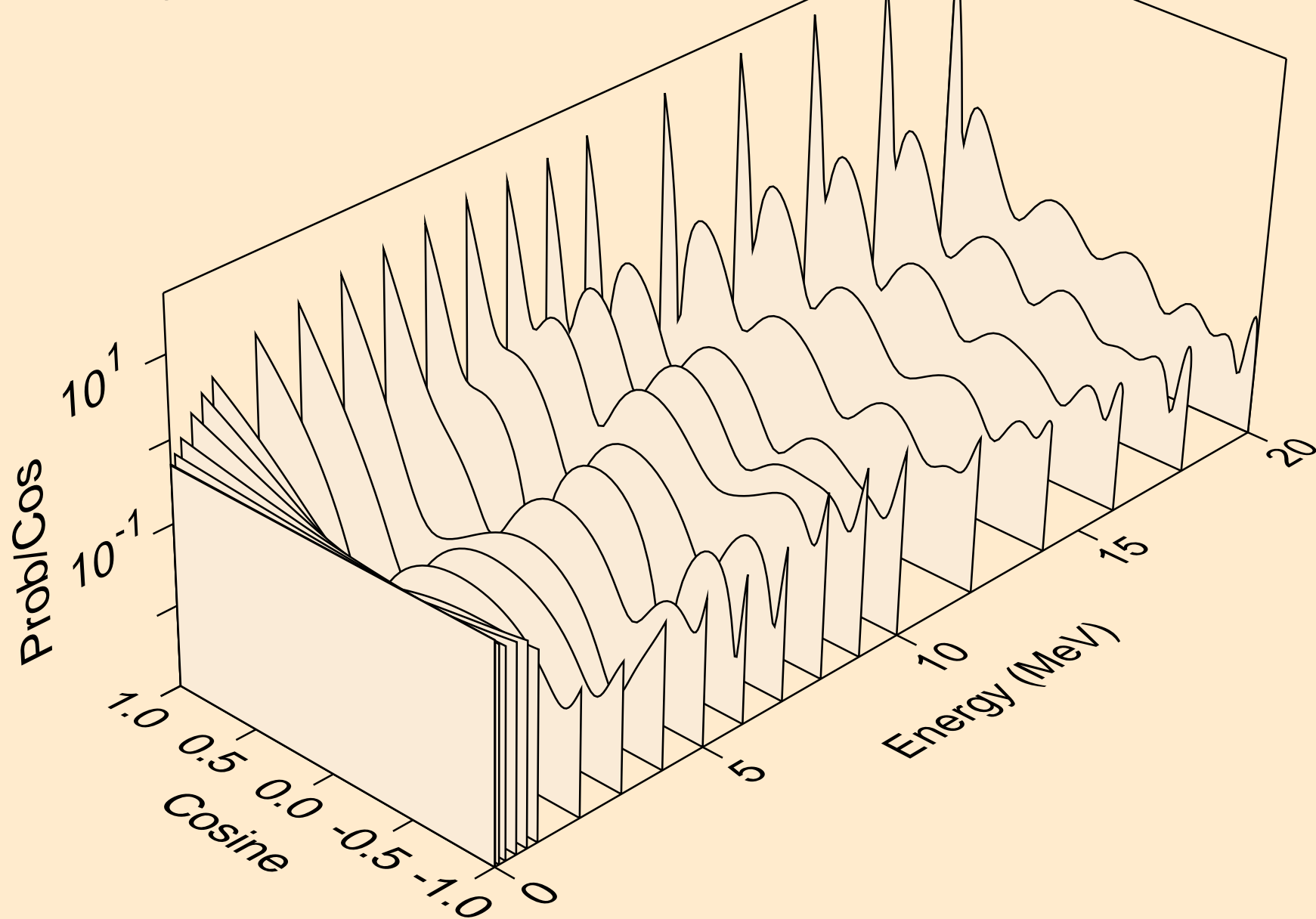

74-W-183 FROM INDL-2008 WITH NJOY99.259.NEA042, FEB. 200
angular distribution for elastic

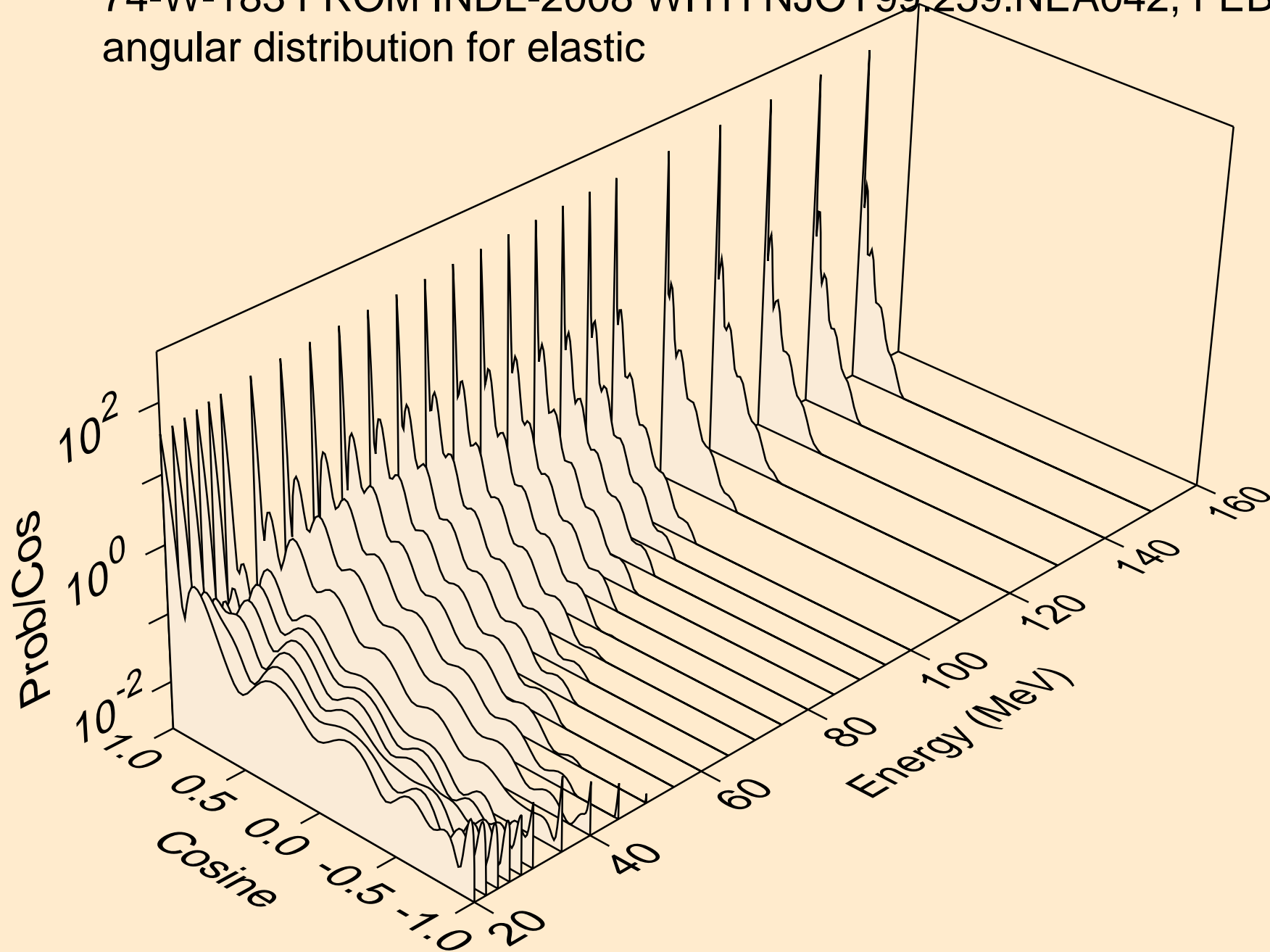

74-W-183 FROM INDL-2008 WITH NJOY99.259.NEA042, FEB. 200
angular distribution for (n,n*1)

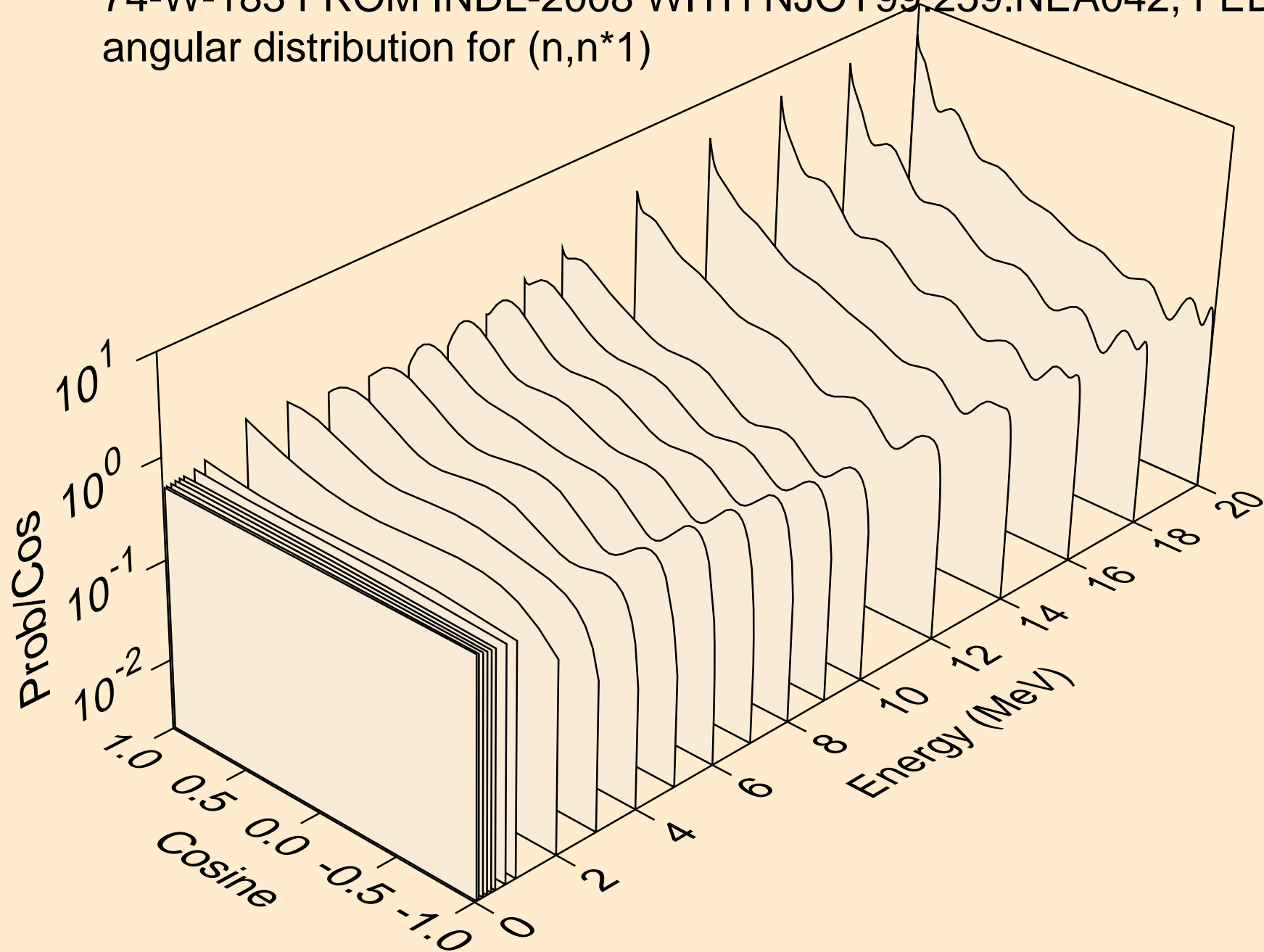

74-W-183 FROM INDL-2008 WITH NJOY99.259.NEA042, FEB. 200
angular distribution for (n,n*2)

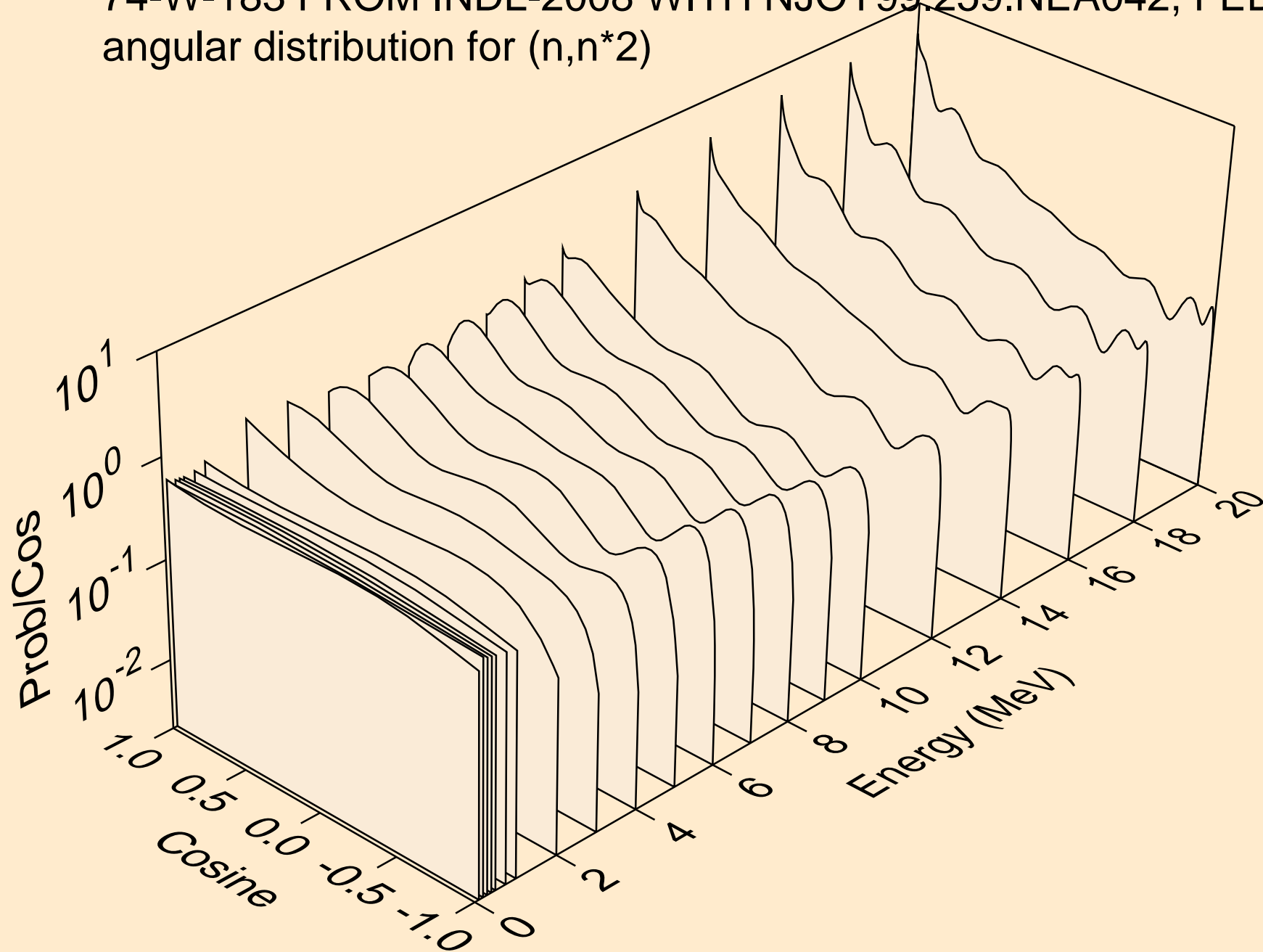

74-W-183 FROM INDL-2008 WITH NJOY99.259.NEA042, FEB. 200
angular distribution for (n,n*3)

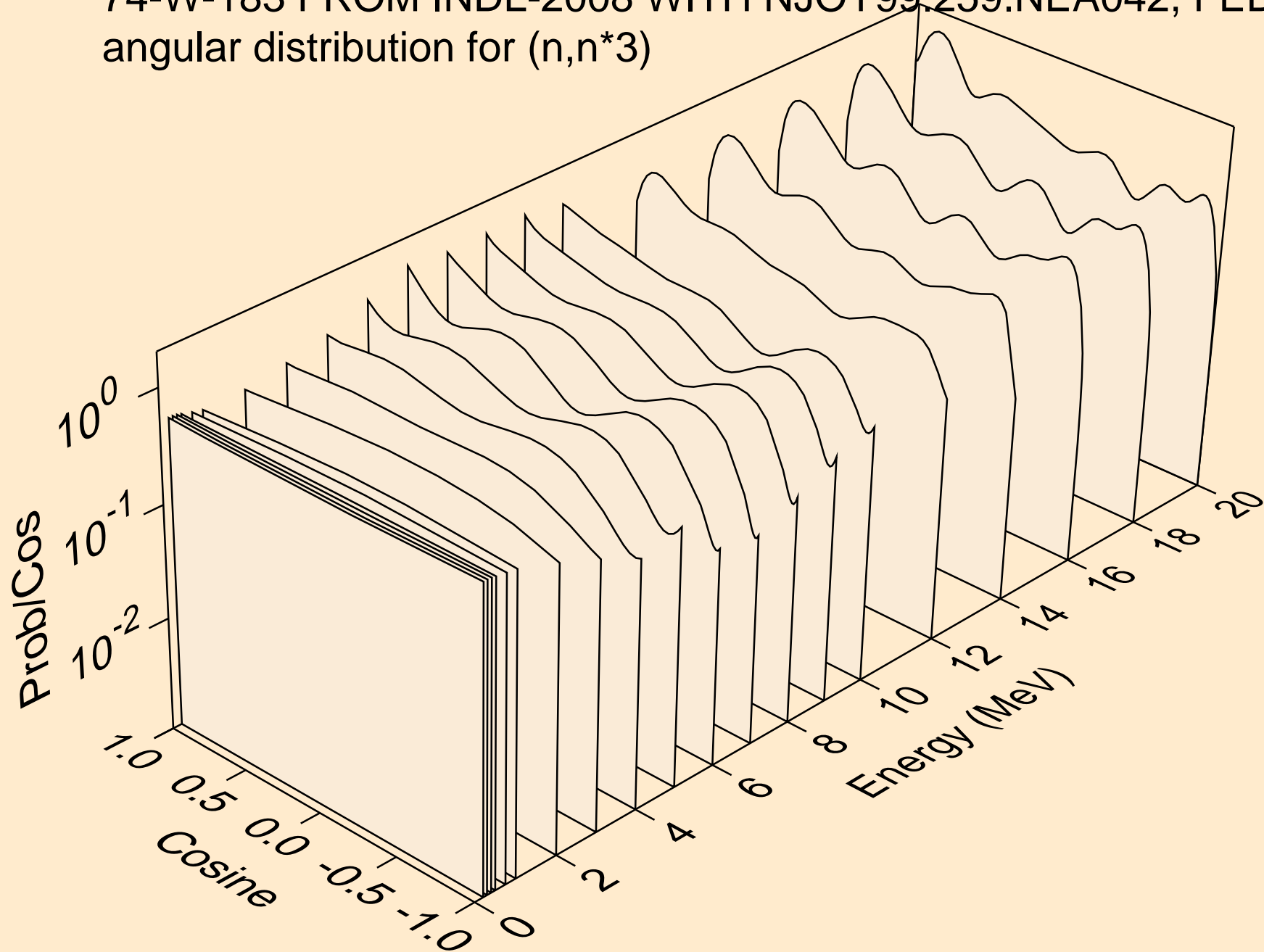

74-W-183 FROM INDL-2008 WITH NJOY99.259.NEA042, FEB. 200
angular distribution for (n,n*4)

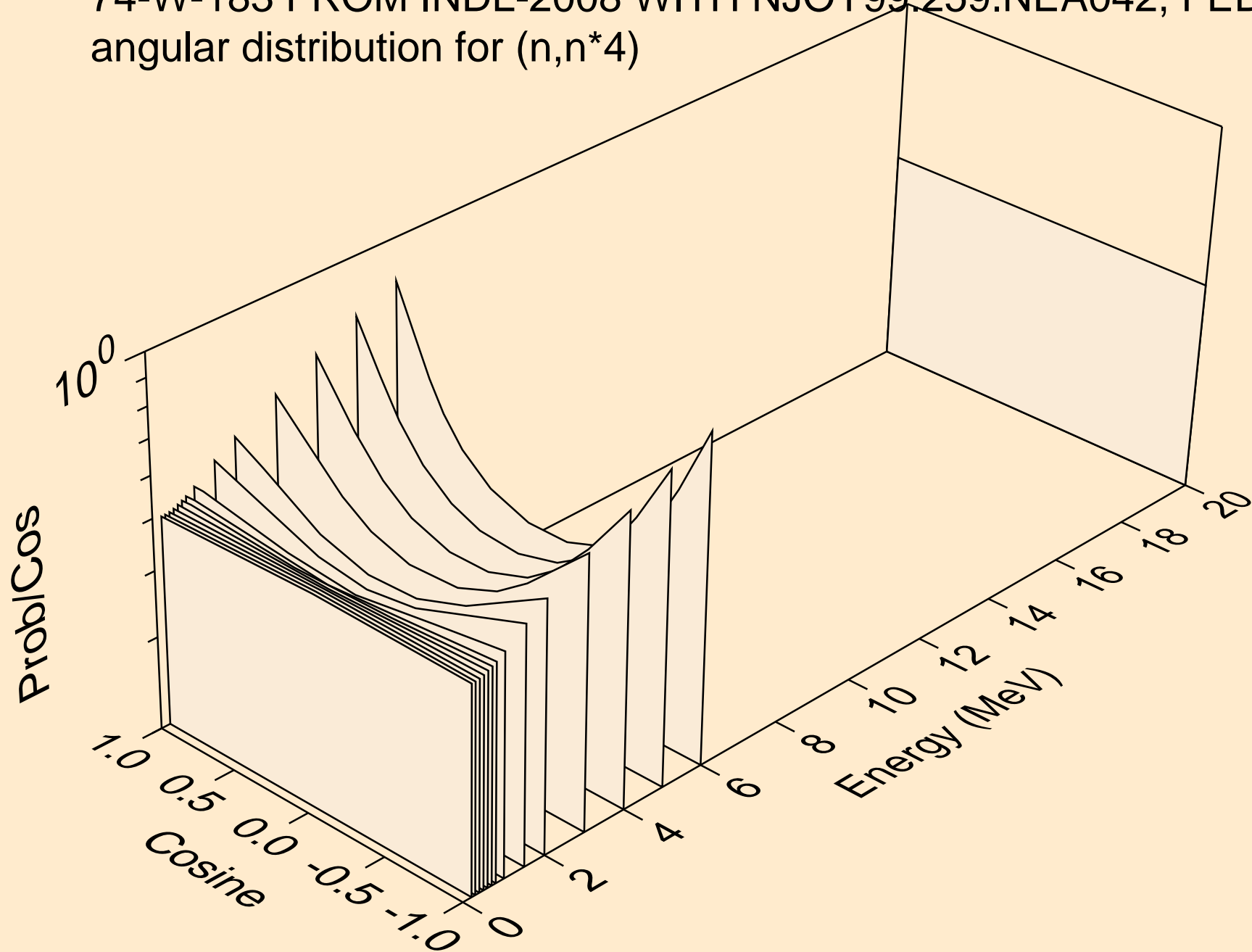

74-W-183 FROM INDL-2008 WITH NJOY99.259.NEA042, FEB. 200
angular distribution for (n,n*5)

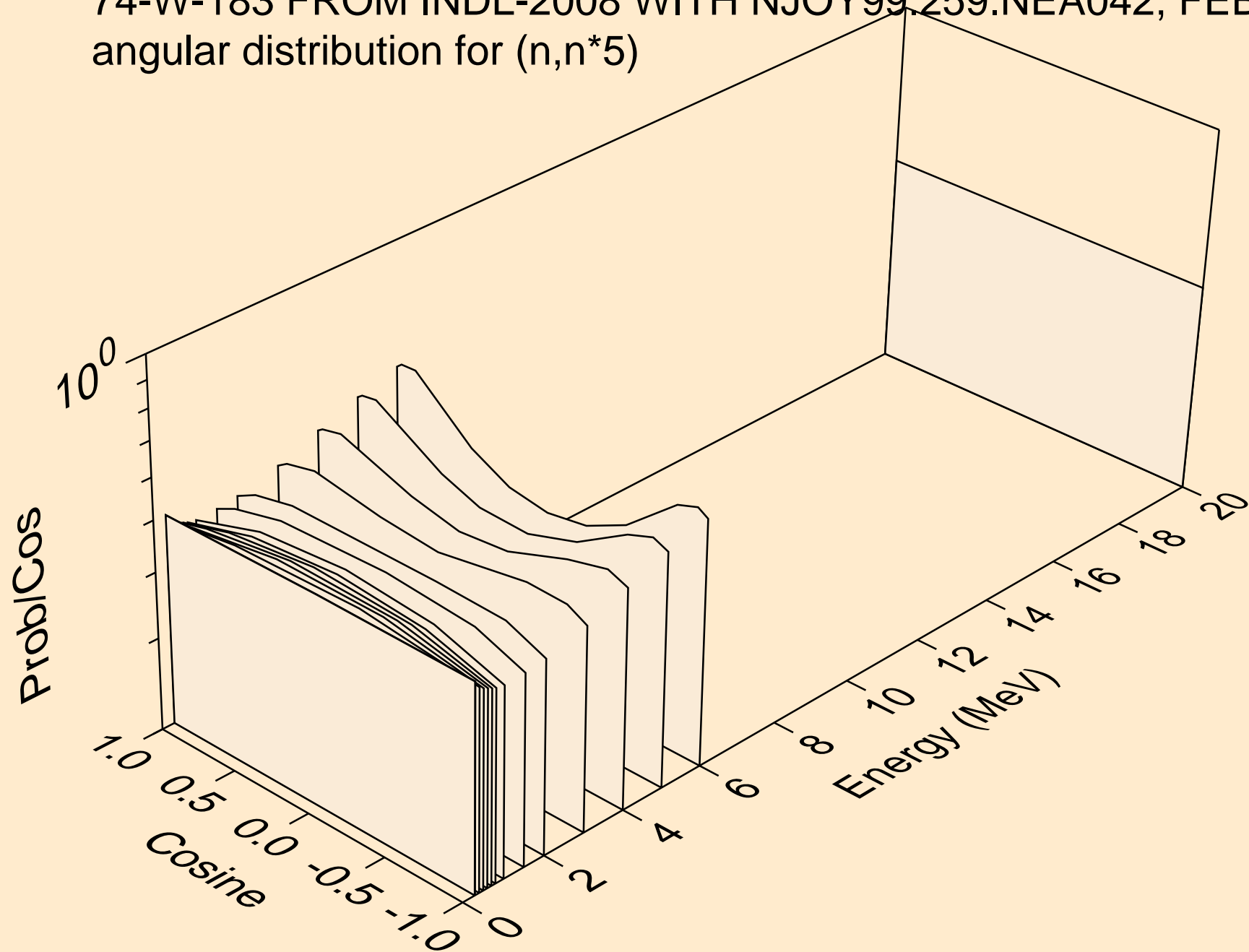

74-W-183 FROM INDL-2008 WITH NJOY99.259.NEA042, FEB. 200
angular distribution for (n,n*6)

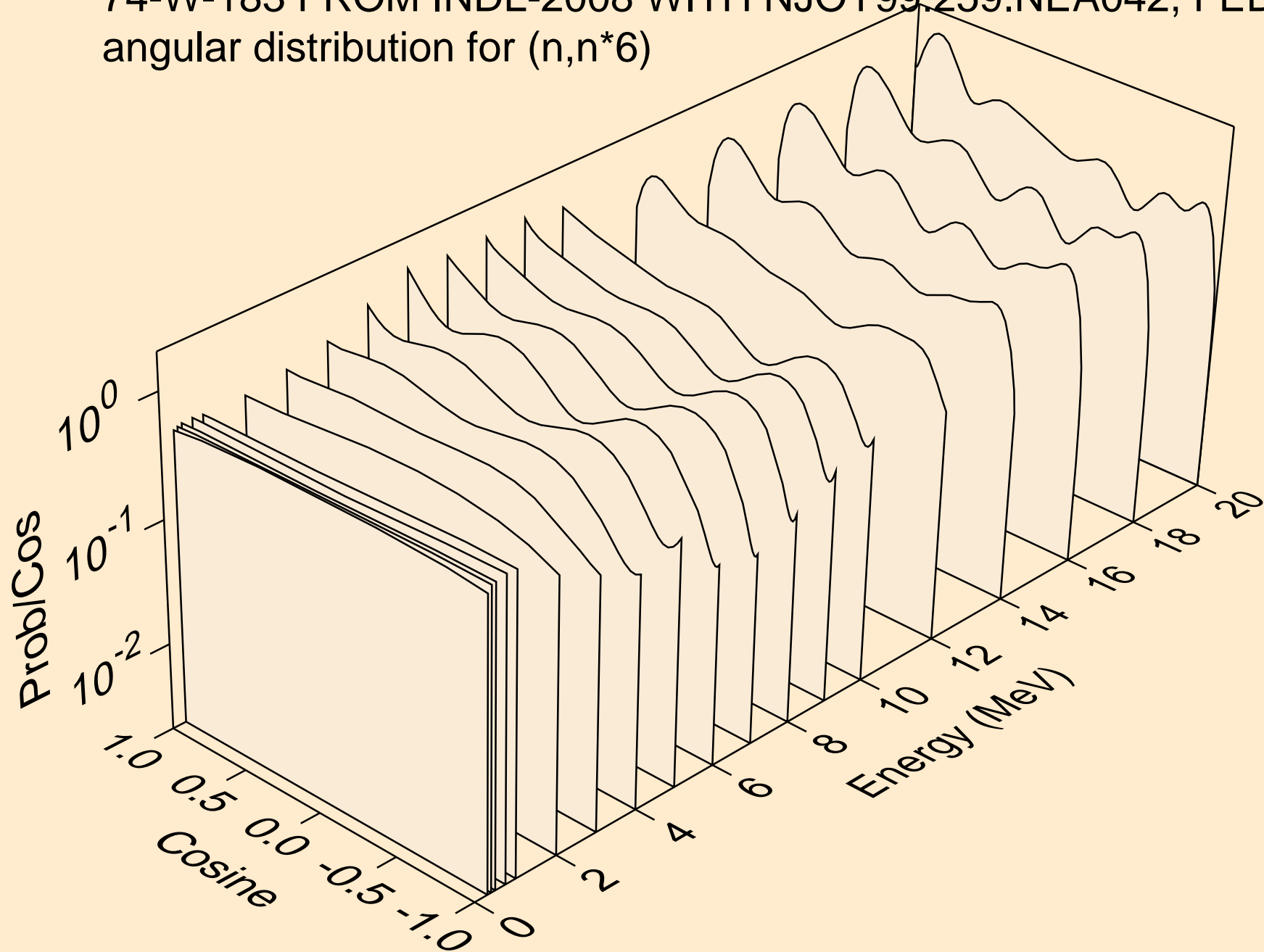

74-W-183 FROM INDL-2008 WITH NJOY99.259.NEA042, FEB. 200
angular distribution for (n,n*7)

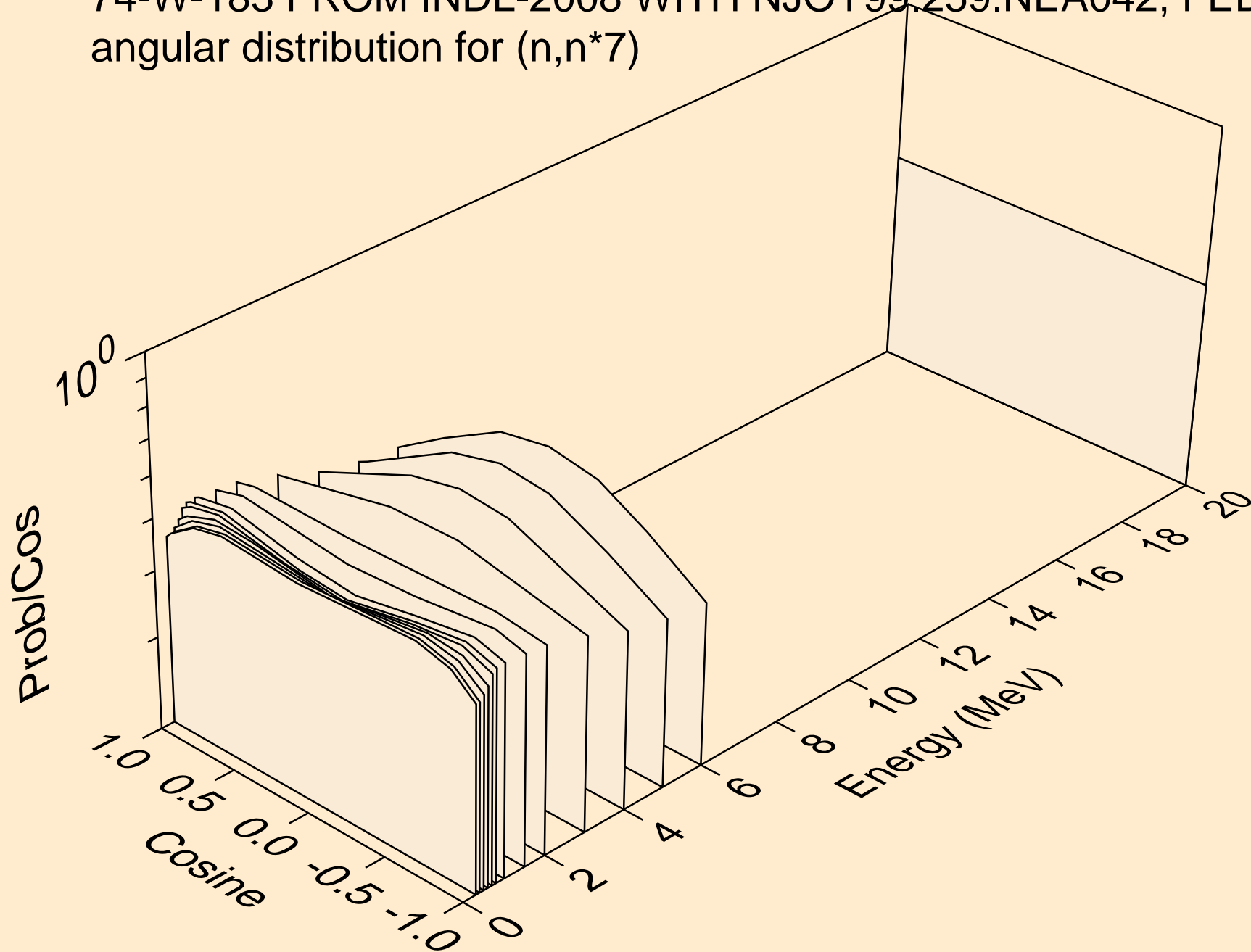

74-W-183 FROM INDL-2008 WITH NJOY99.259.NEA042, FEB. 200
angular distribution for (n,n*8)

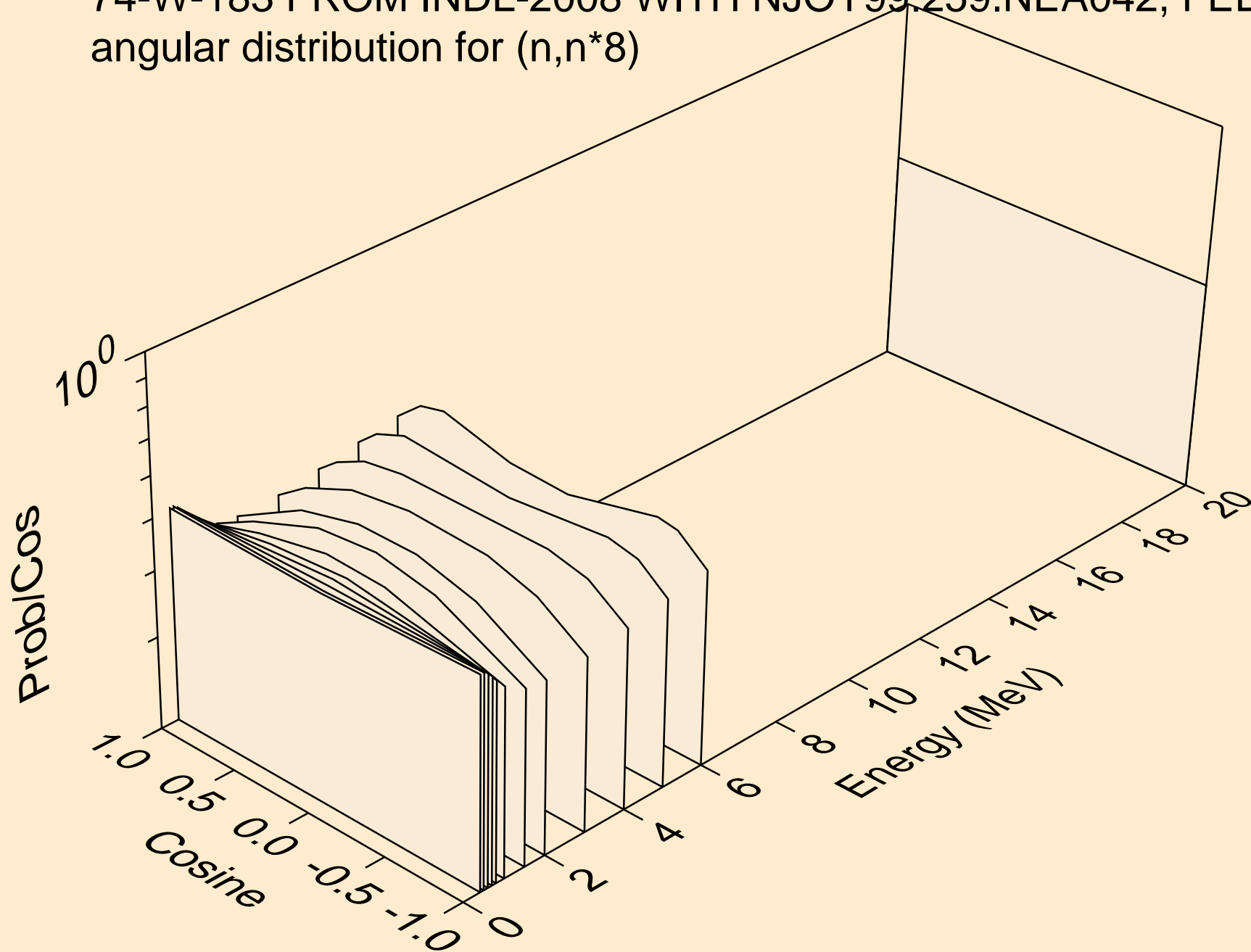

74-W-183 FROM INDL-2008 WITH NJOY99.259.NEA042, FEB. 200
angular distribution for (n,n*9)

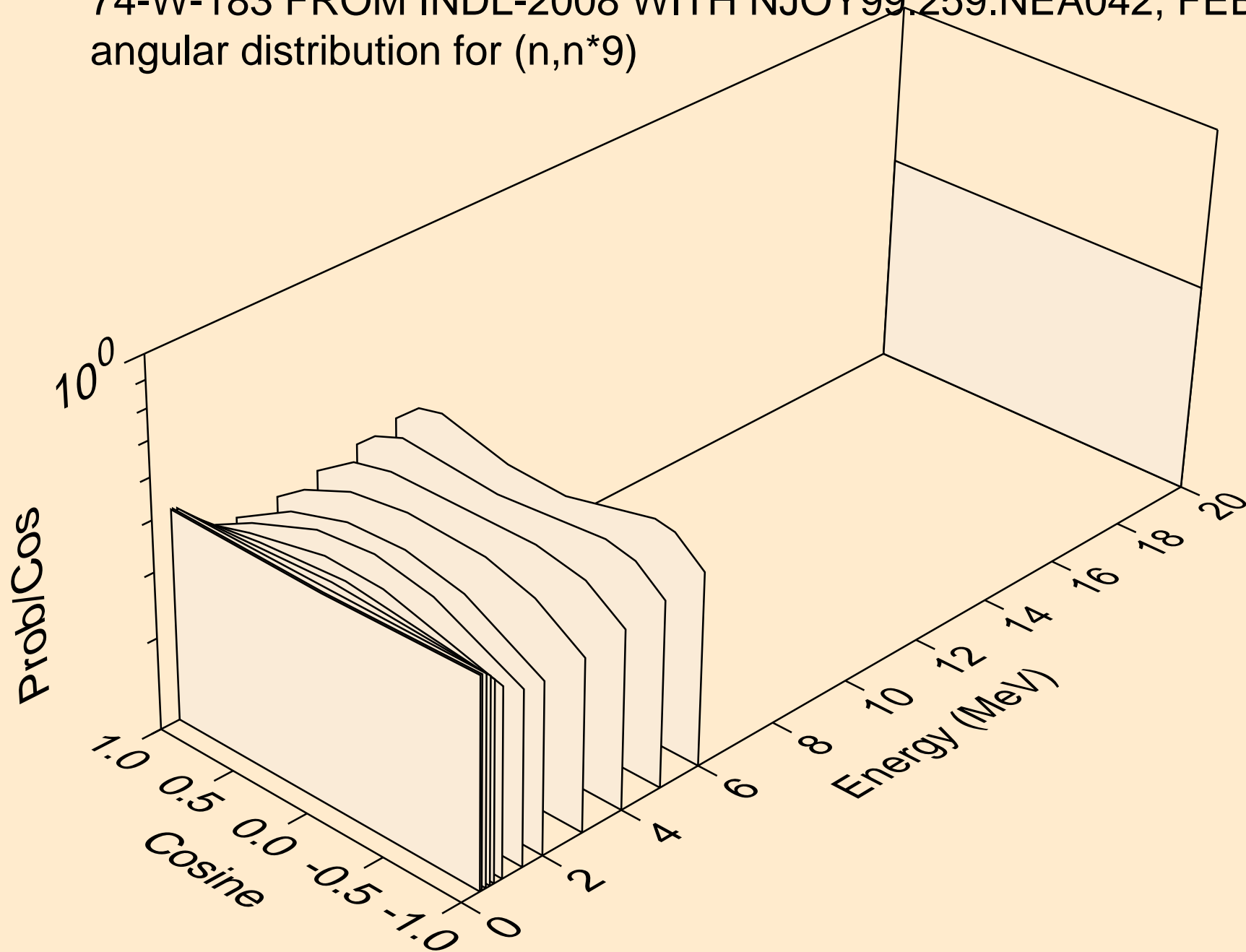

74-W-183 FROM INDL-2008 WITH NJOY99.259.NEA042, FEB. 200
angular distribution for (n,n*10)

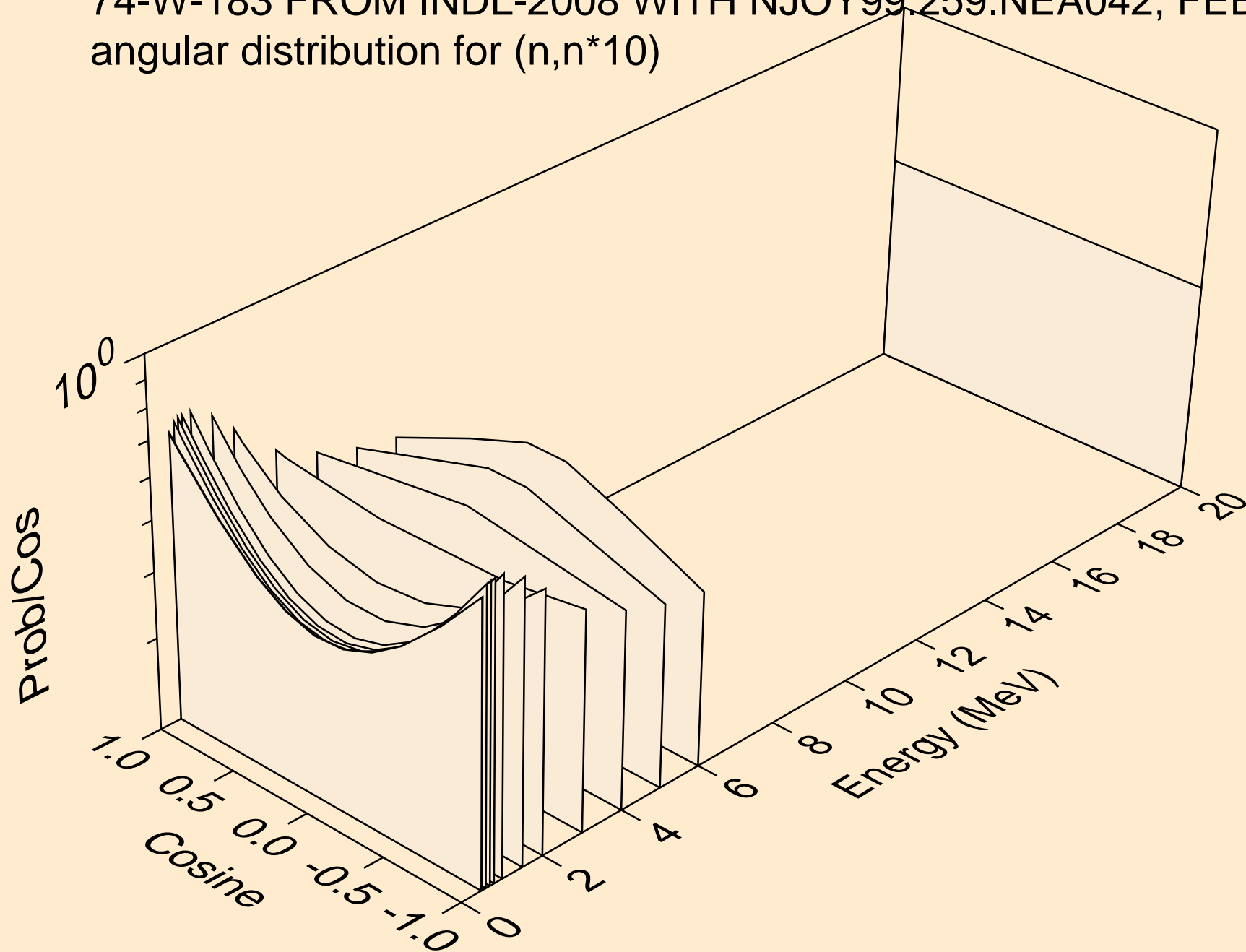

74-W-183 FROM INDL-2008 WITH NJOY99.259.NEA042, FEB. 200
angular distribution for (n,n*11)

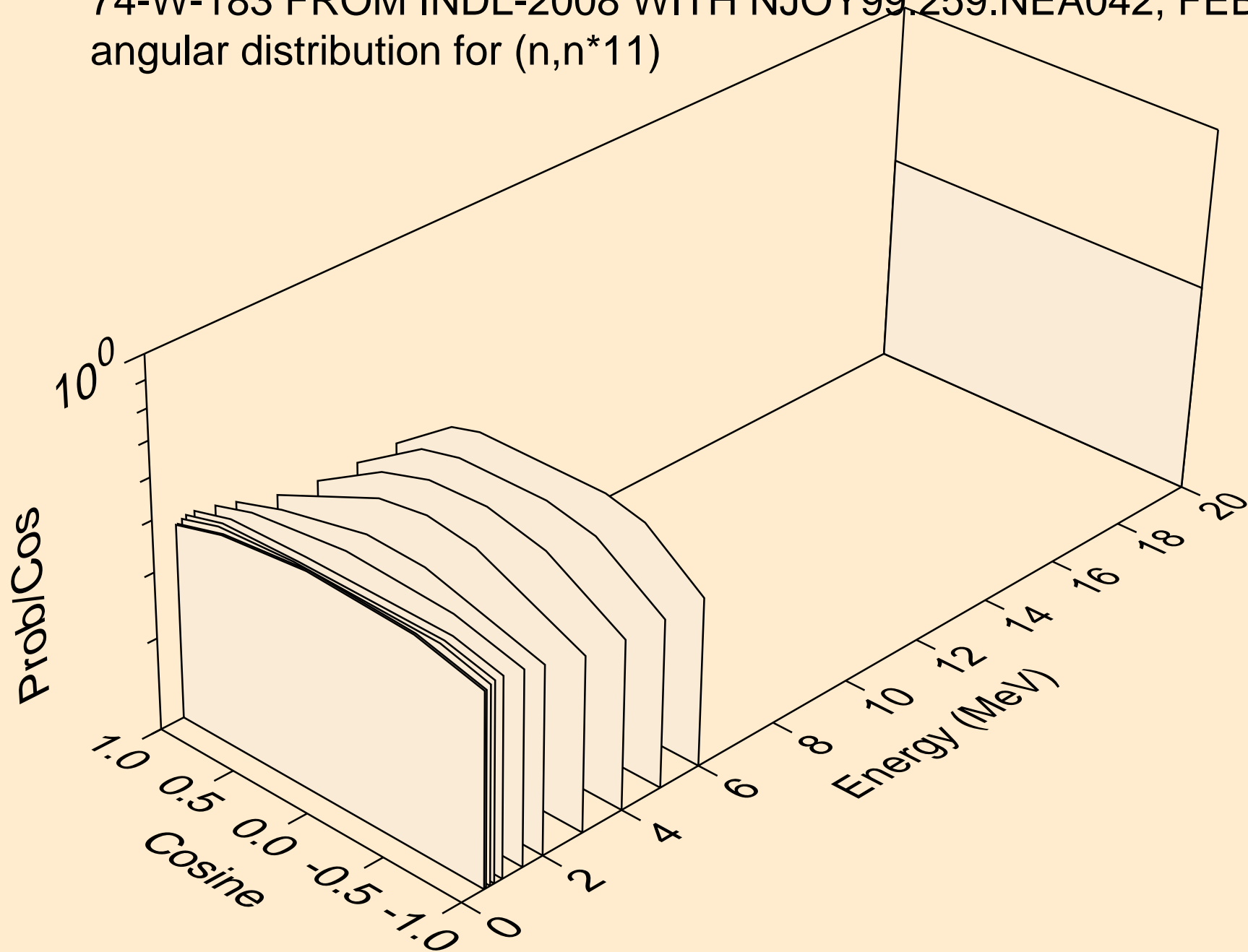

74-W-183 FROM INDL-2008 WITH NJOY99.259.NEA042, FEB. 200
angular distribution for (n,n*12)

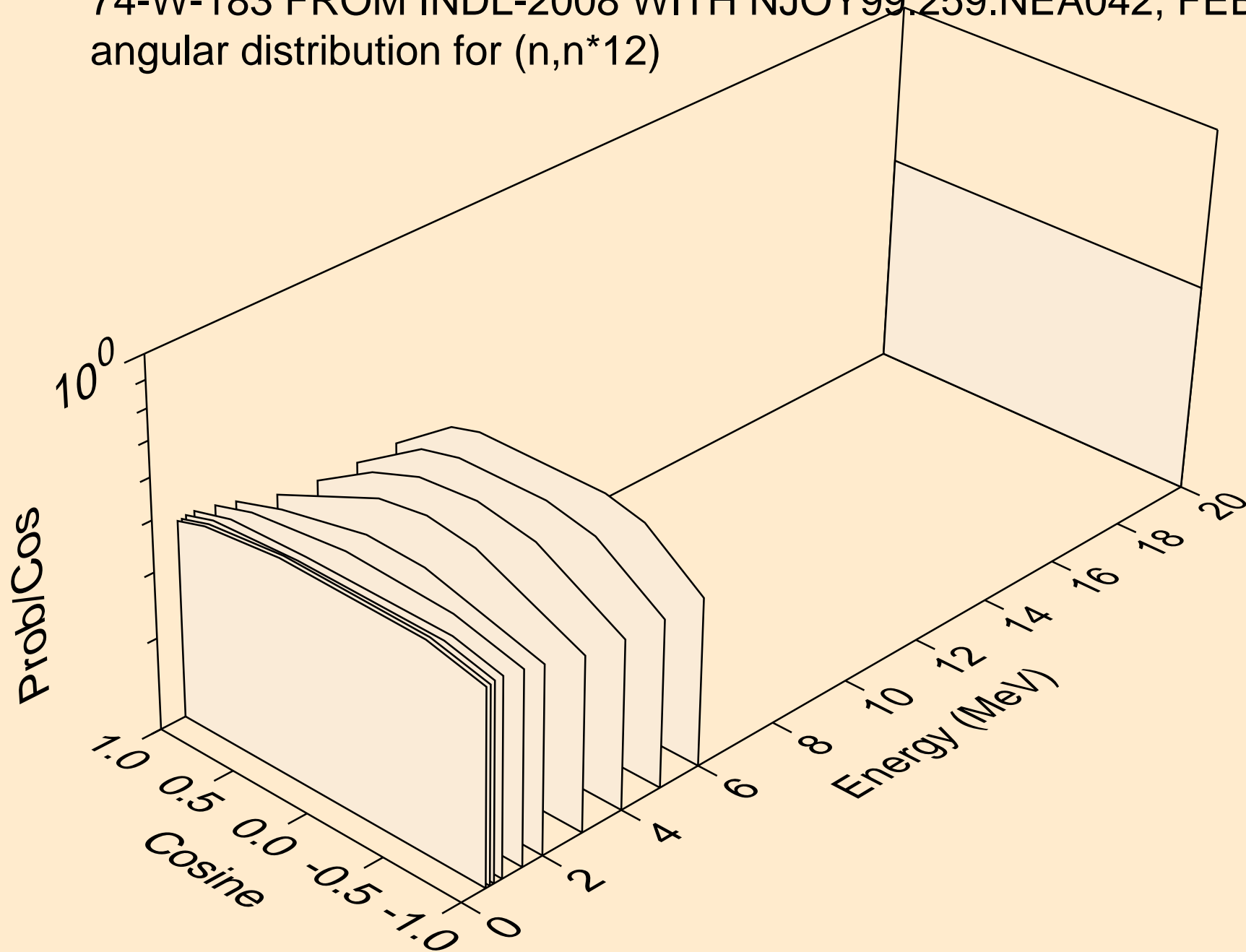

74-W-183 FROM INDL-2008 WITH NJOY99.259.NEA042, FEB. 200
angular distribution for (n,n*13)

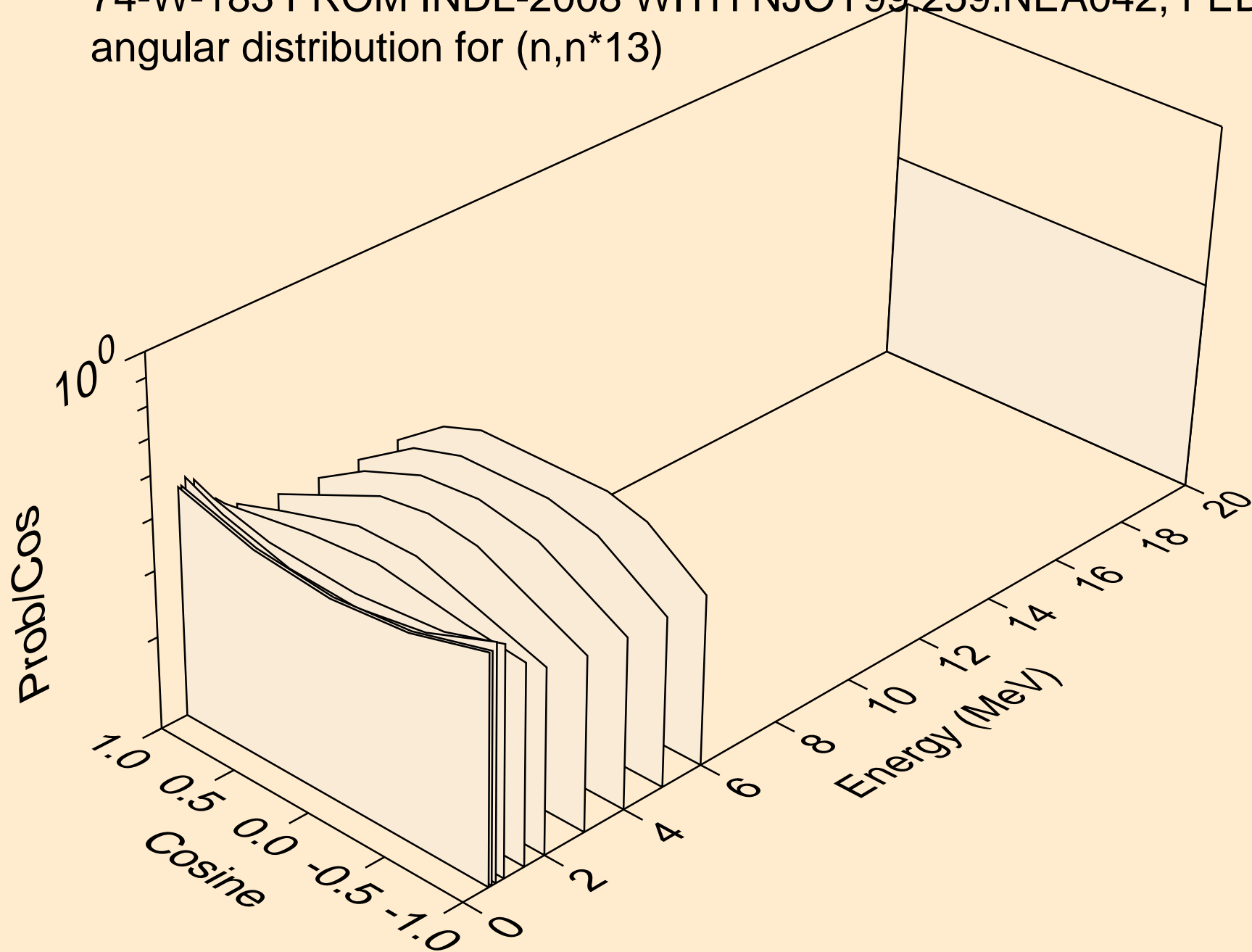

74-W-183 FROM INDL-2008 WITH NJOY99.259.NEA042, FEB. 200
angular distribution for (n,n*14)

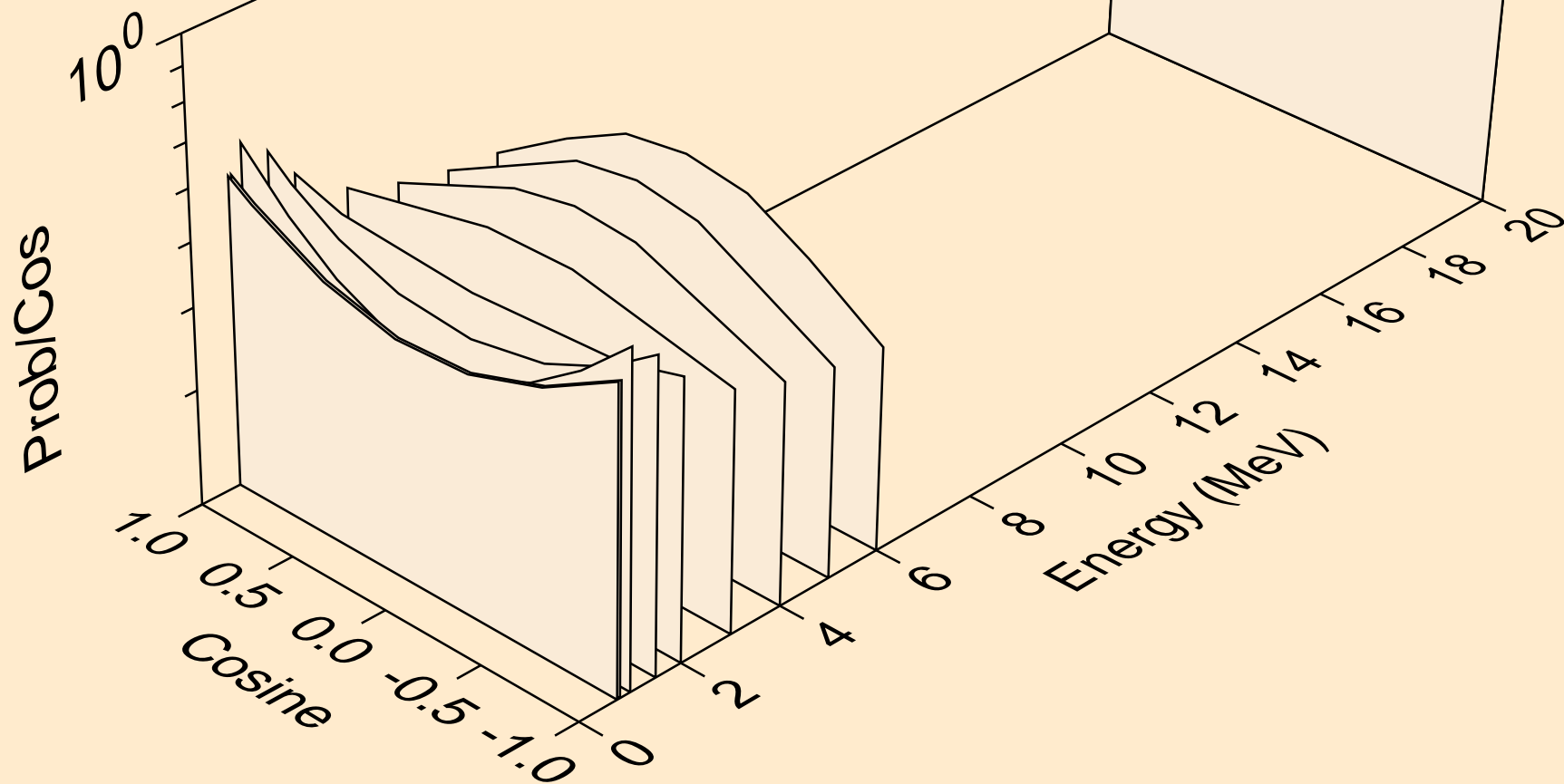

74-W-183 FROM INDL-2008 WITH NJOY99.259.NEA042, FEB. 200
Neutron emission for (n,x)

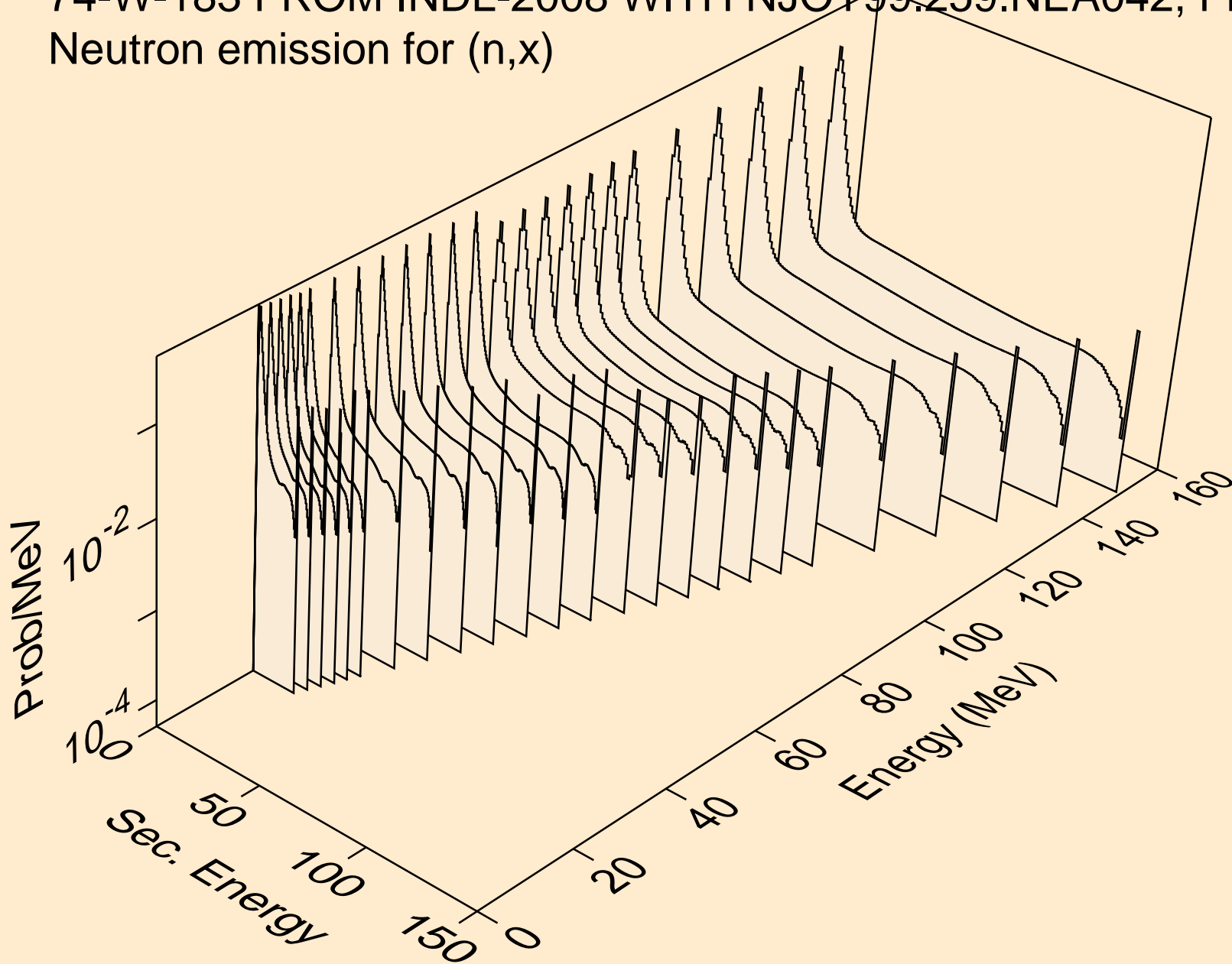

74-W-183 FROM INDL-2008 WITH NJOY99.259.NEA042, FEB. 200
Neutron emission for (n,2n)

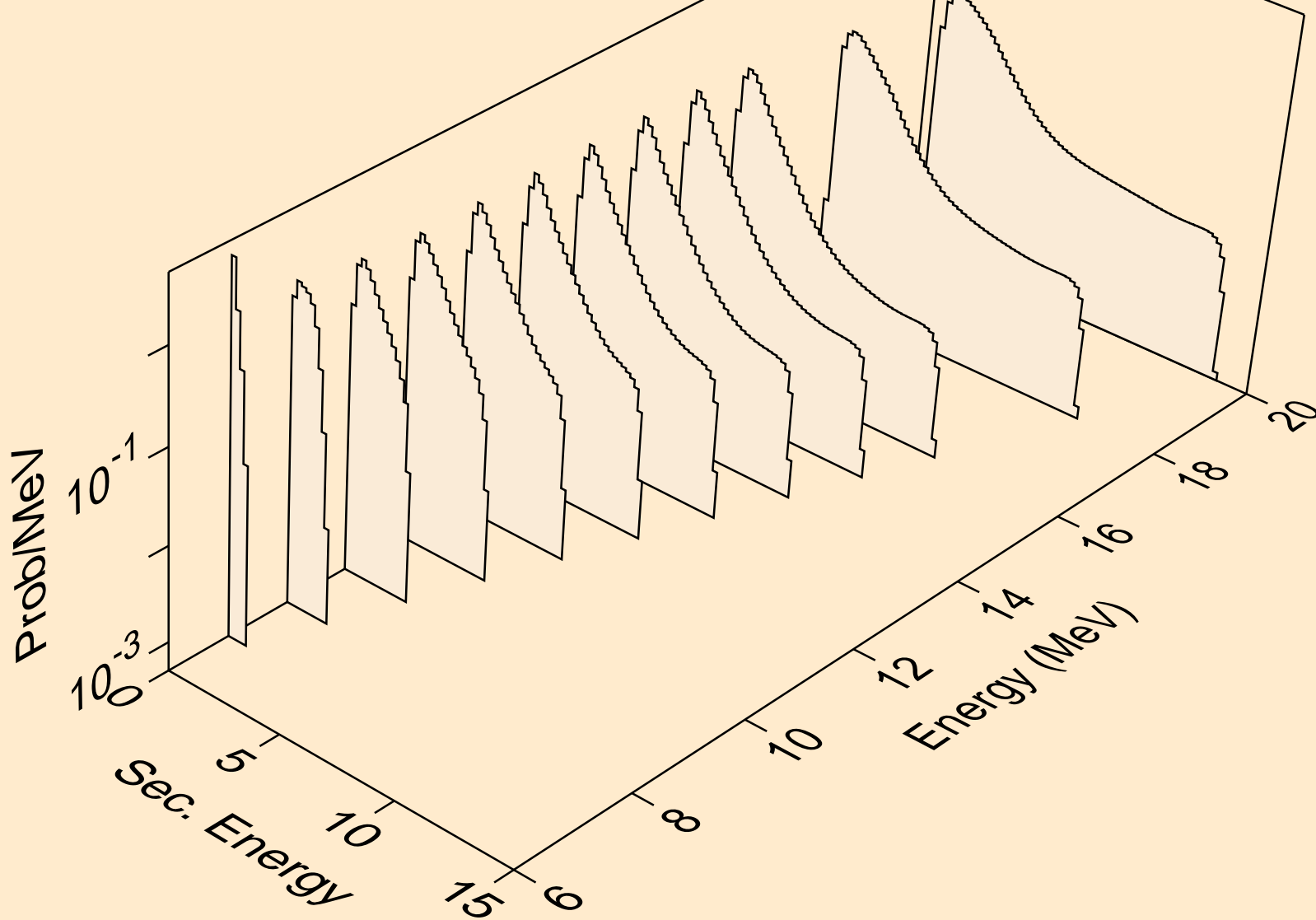

74-W-183 FROM INDL-2008 WITH NJOY99.259.NEA042, FEB. 200
Neutron emission for (n,3n)

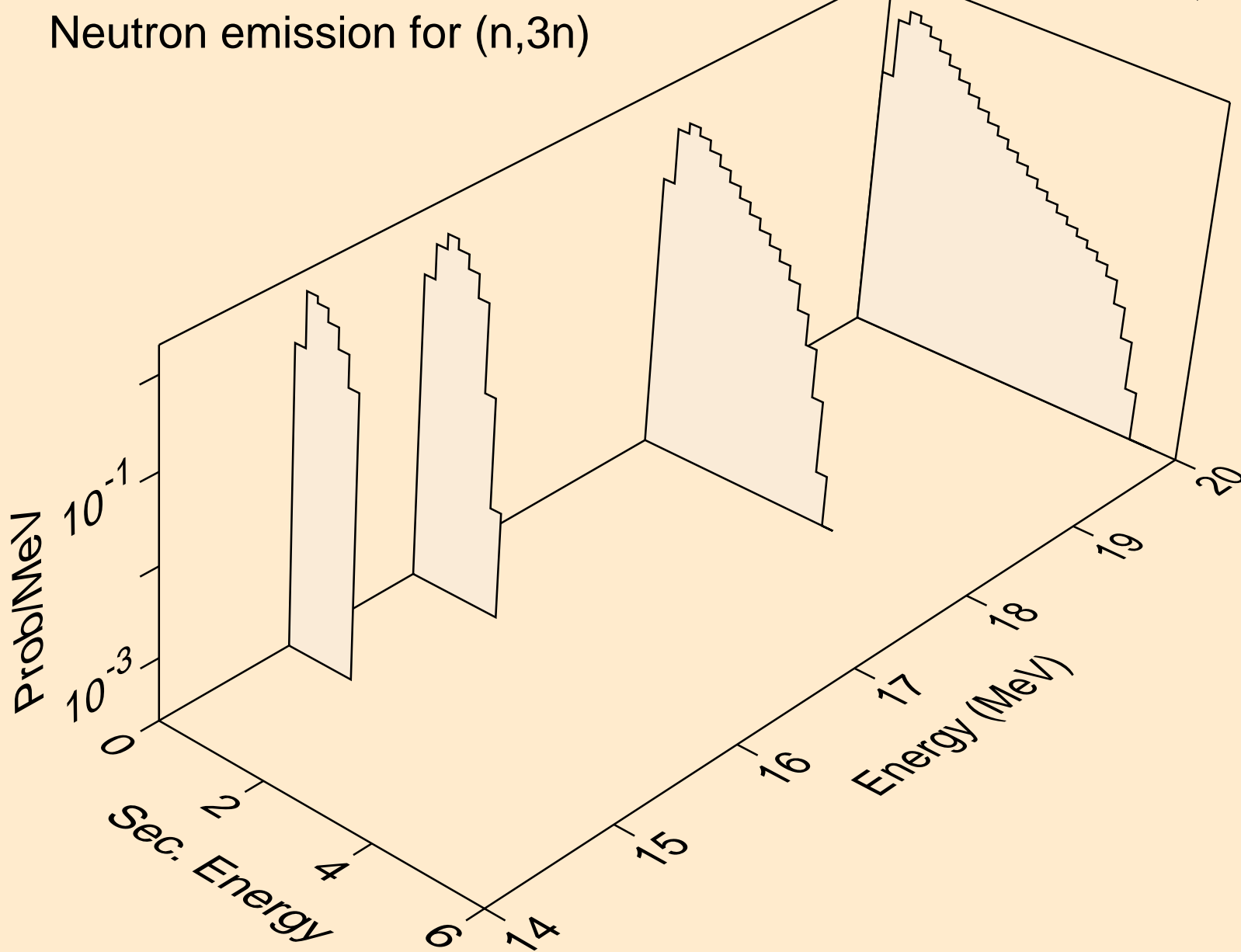

74-W-183 FROM INDL-2008 WITH NJOY99.259.NEA042, FEB. 200
Neutron emission for (n,n*)a

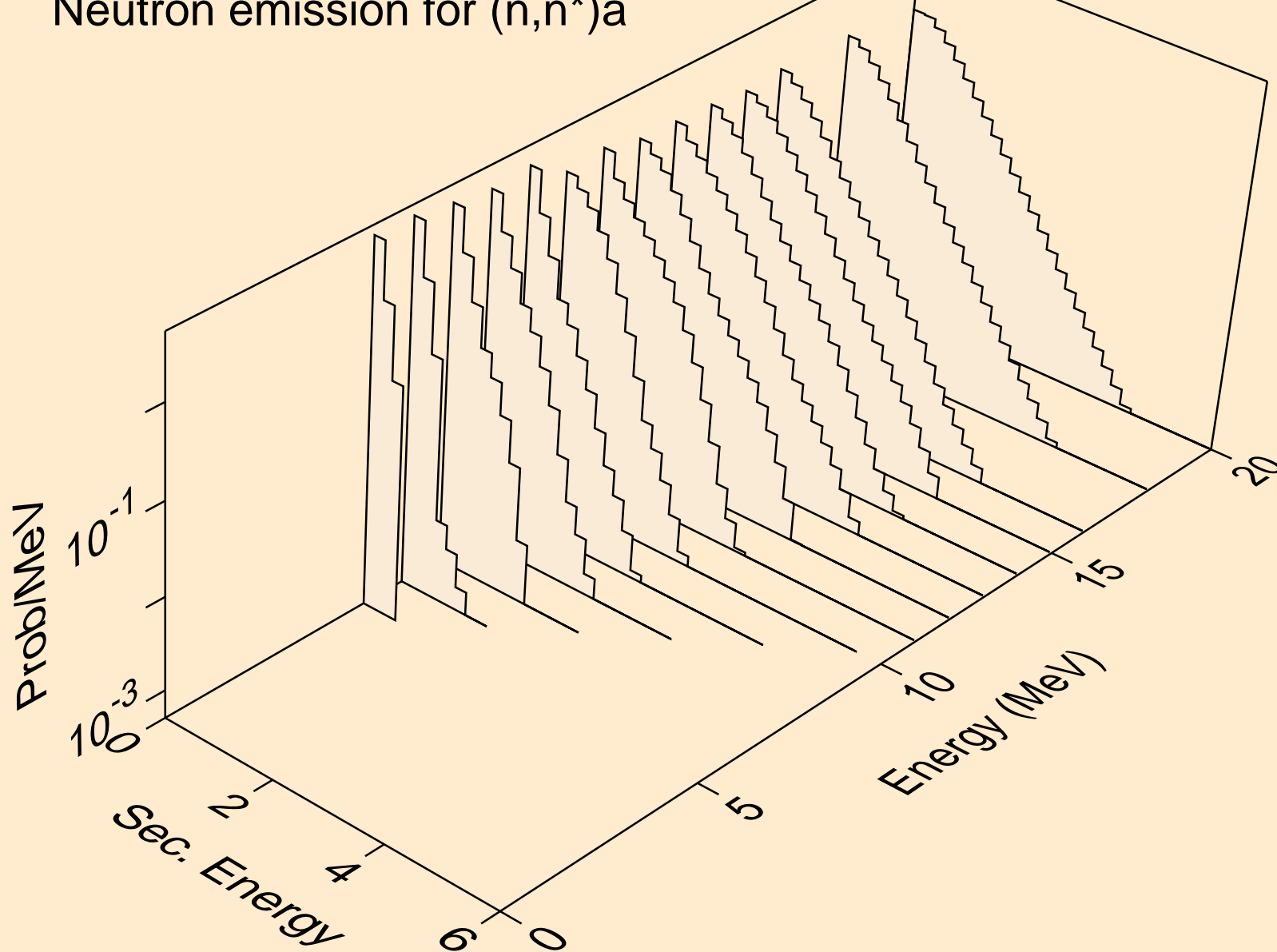

74-W-183 FROM INDL-2008 WITH NJOY99.259.NEA042, FEB. 200
Neutron emission for (n,2n)a

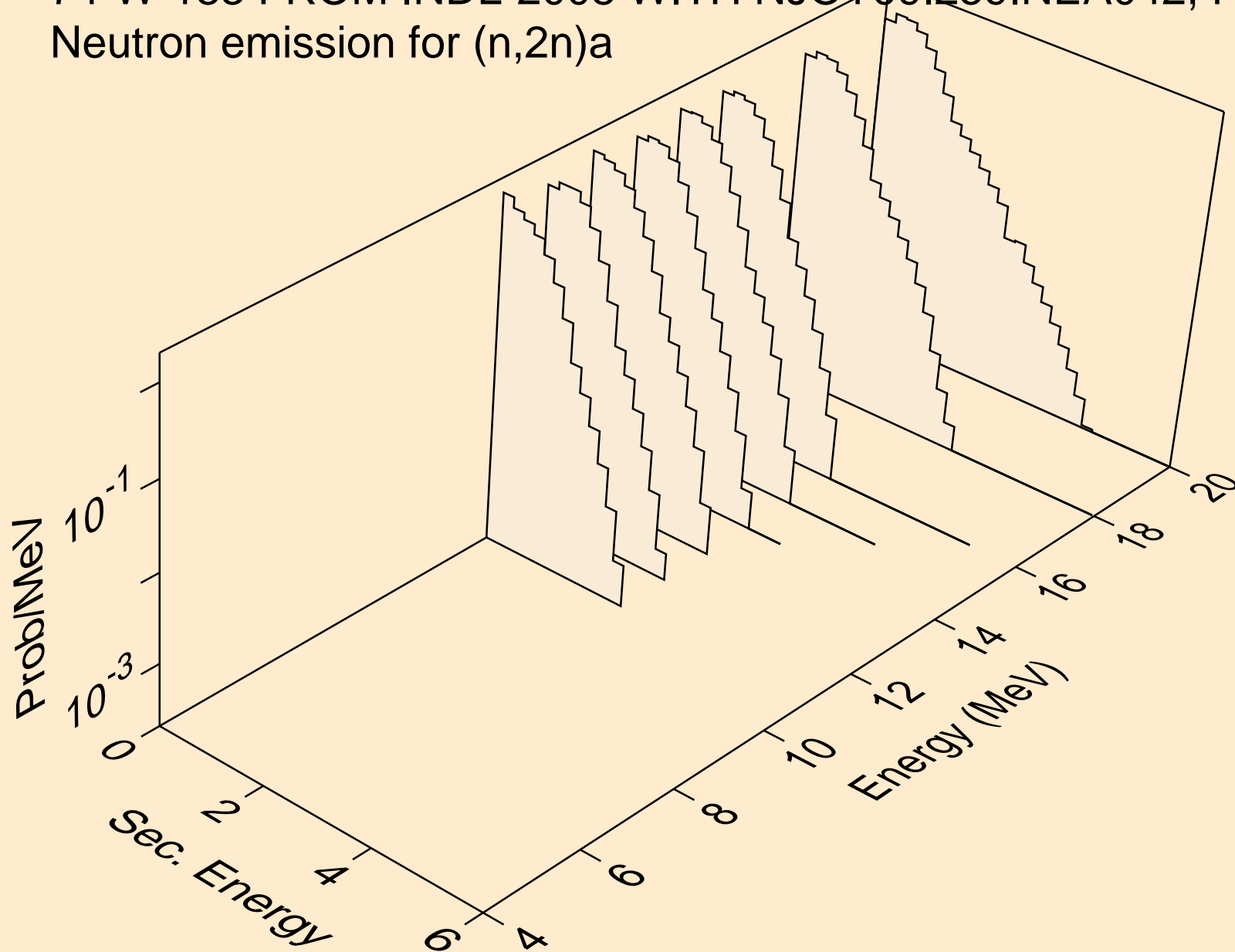

74-W-183 FROM INDL-2008 WITH NJOY99.259.NEA042, FEB. 200
Neutron emission for (n,n*)p

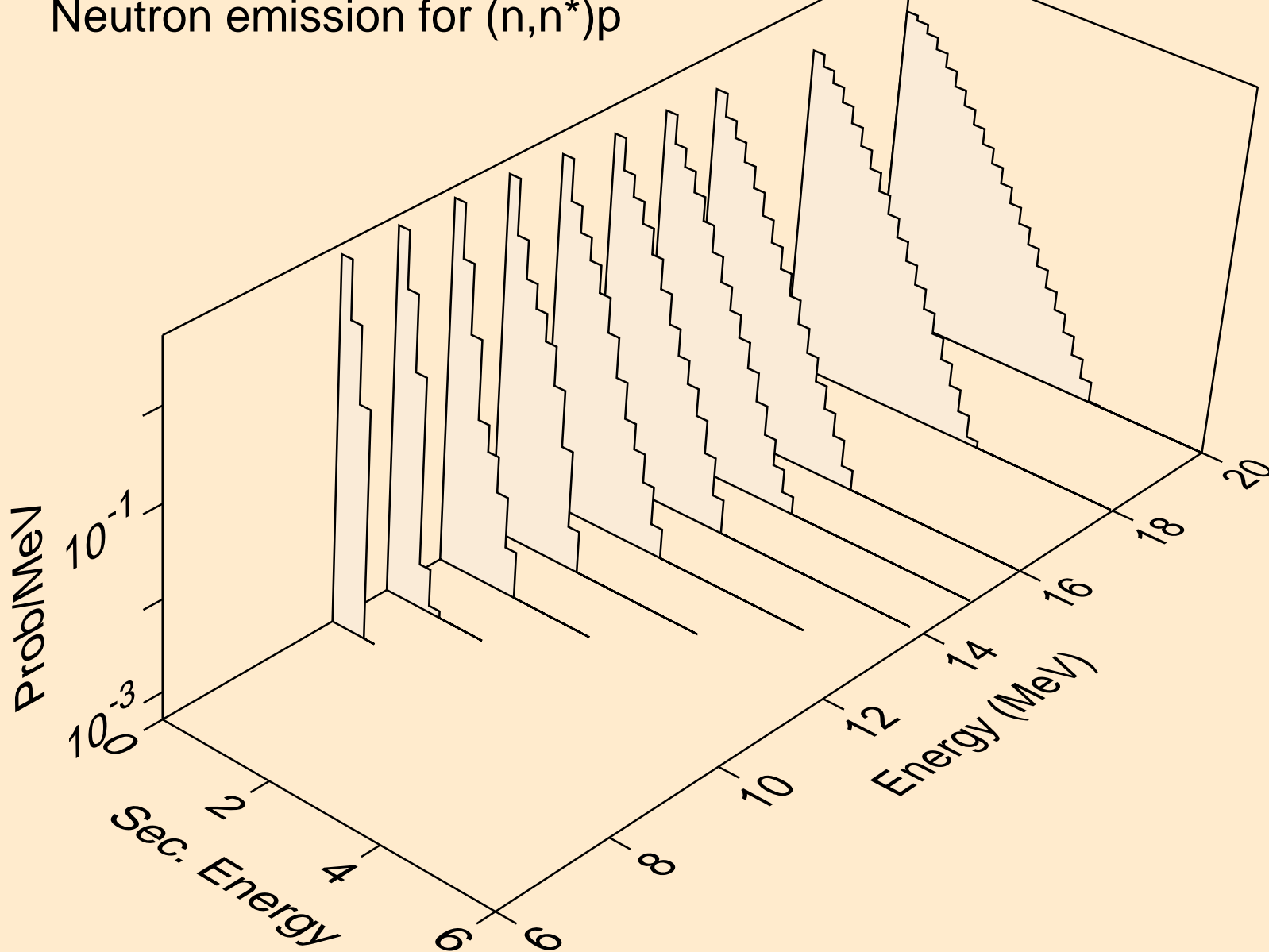

74-W-183 FROM INDL-2008 WITH NJOY99.259.NEA042, FEB. 200
Neutron emission for (n,2np)

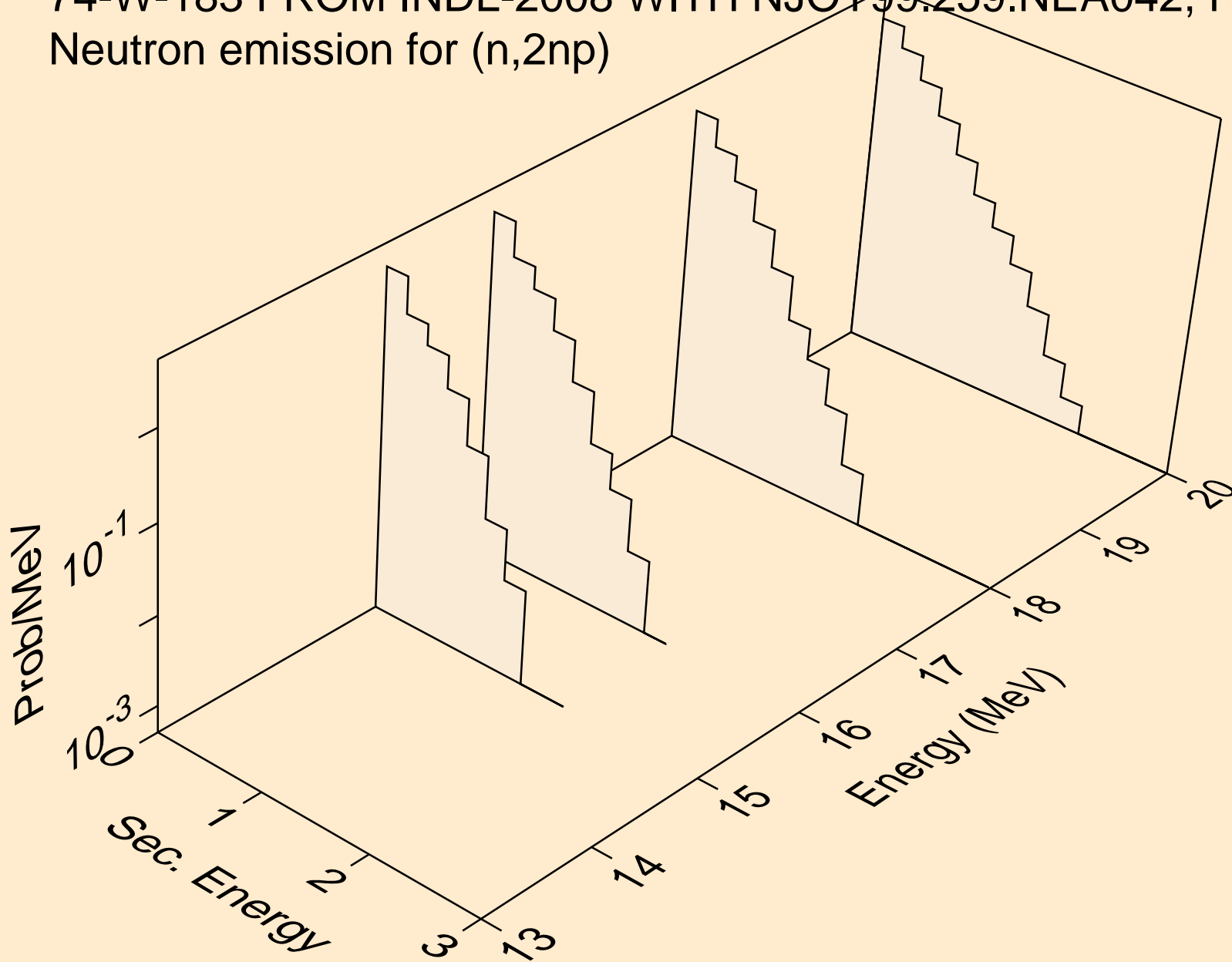

74-W-183 FROM INDL-2008 WITH NJOY99.259.NEA042, FEB. 200
Neutron emission for (n,n*c)

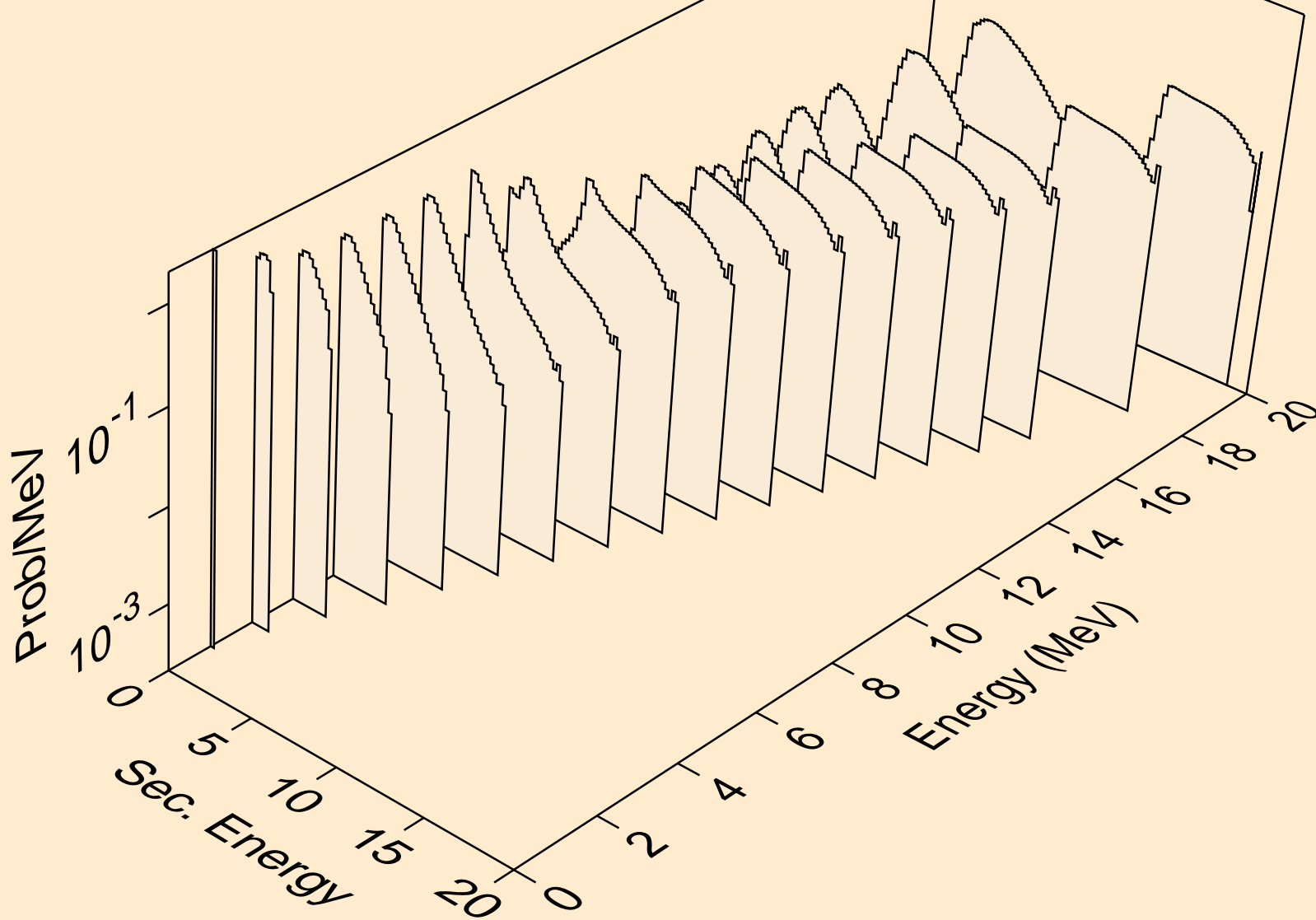

74-W-183 FROM INDL-2008 WITH NJOY99.259.NEA042, FEB. 200
Photon emission for (n,gma)

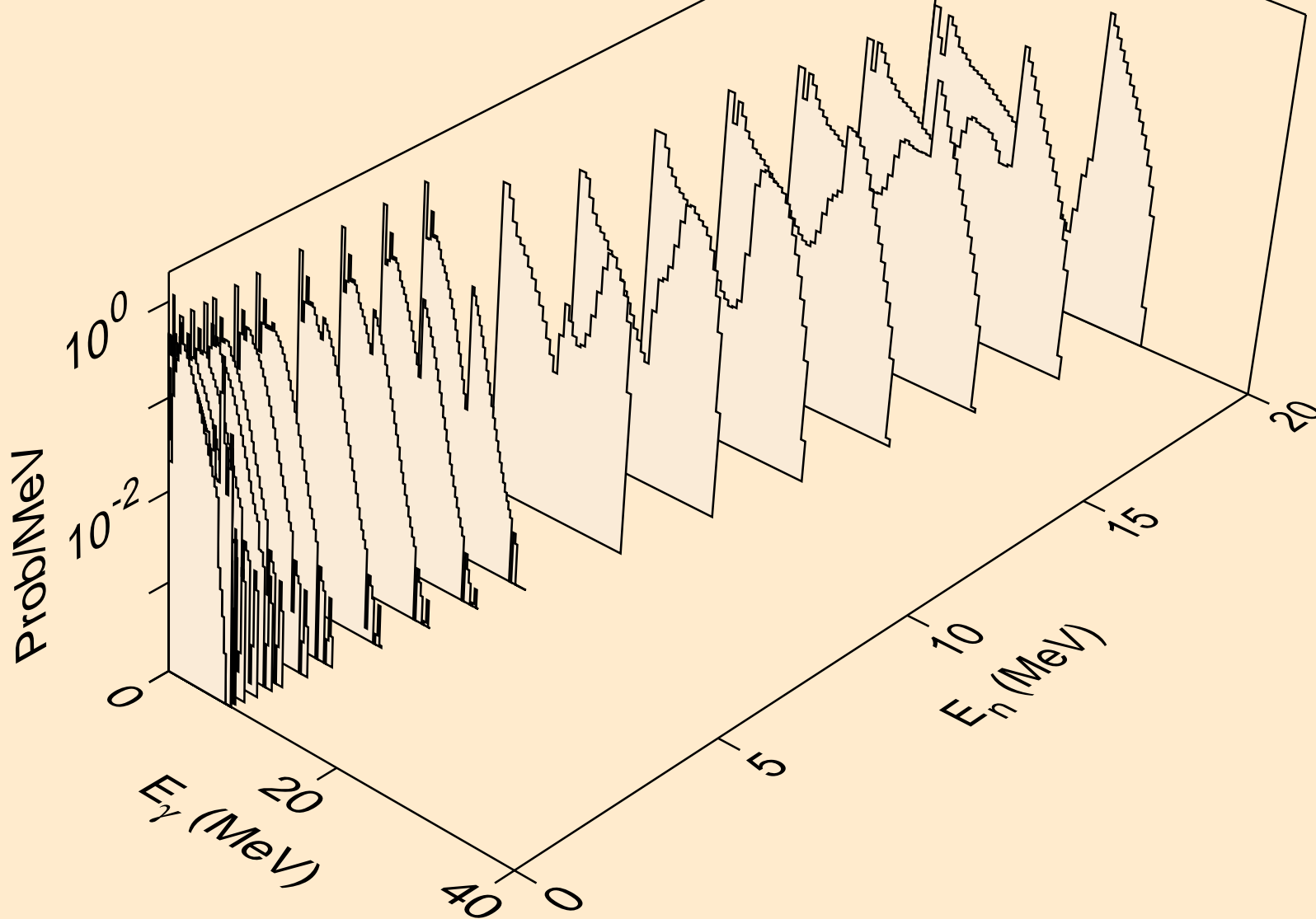

74-W-183 FROM INDL-2008 WITH NJOY99.259.NEA042, FEB. 200
Photon emission for inelastic

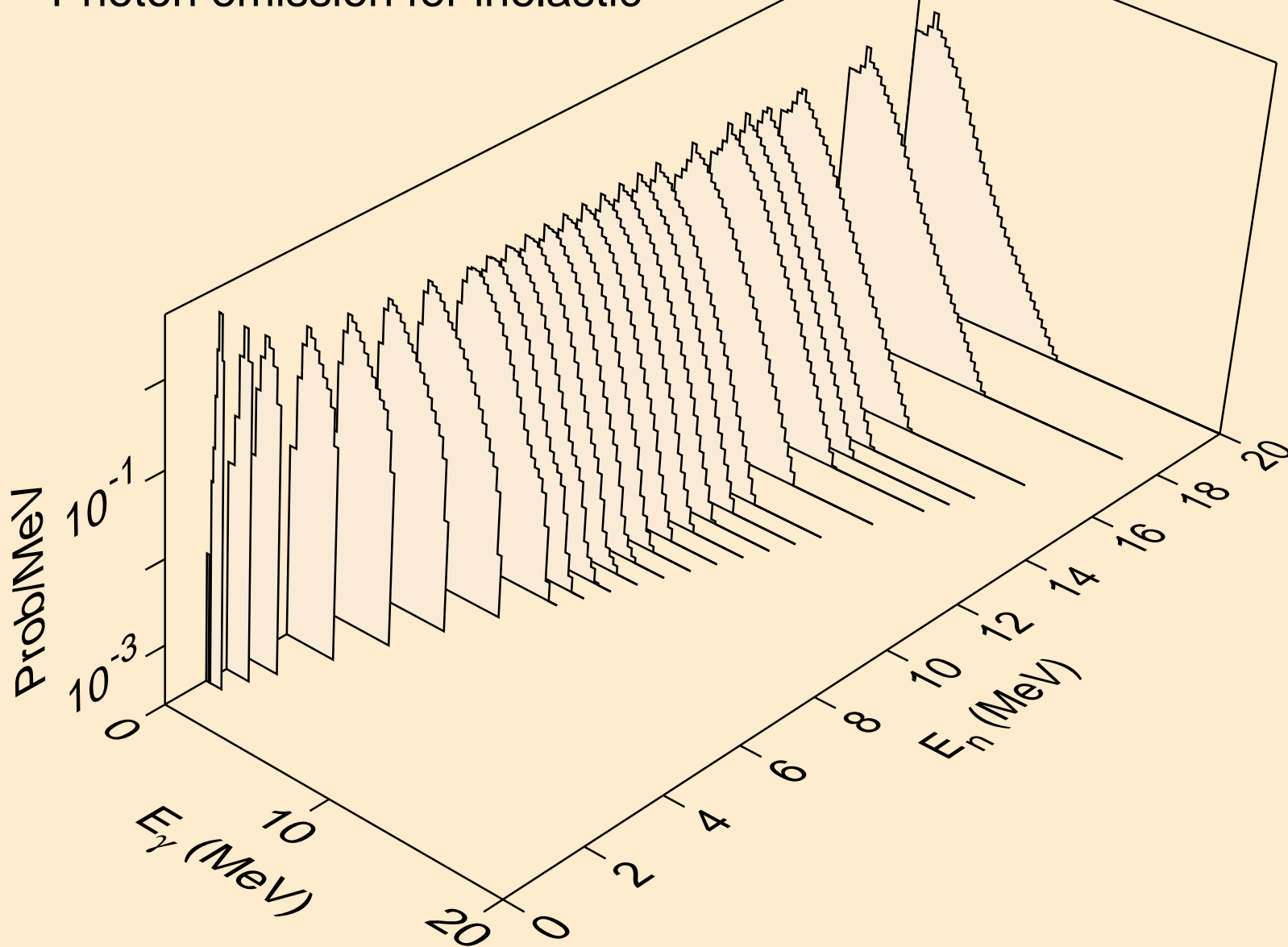

74-W-183 FROM INDL-2008 WITH NJOY99.259.NEA042, FEB. 200
Photon emission for (n,2n)

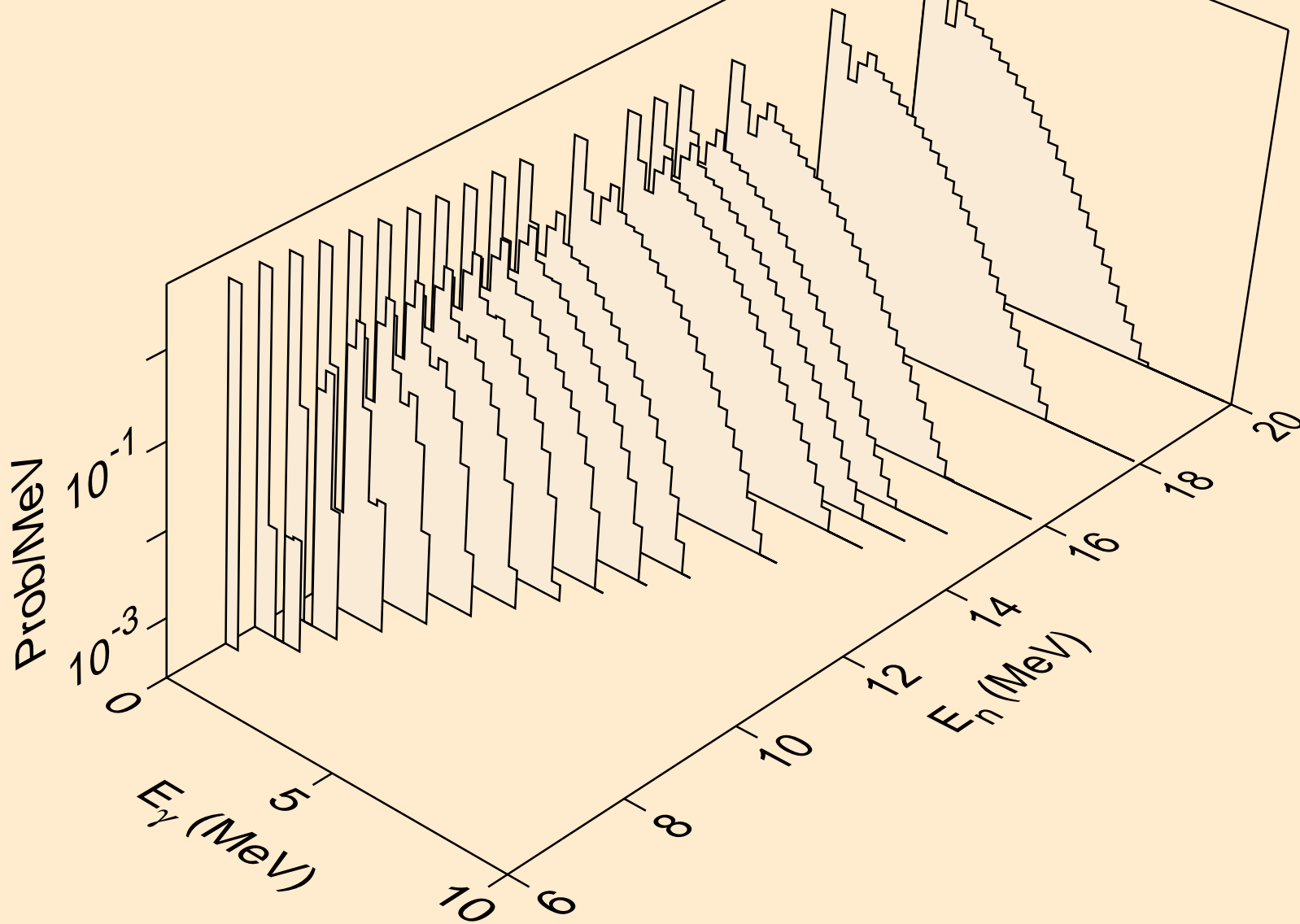

74-W-183 FROM INDL-2008 WITH NJOY99.259.NEA042, FEB. 200
Photon emission for (n,3n)

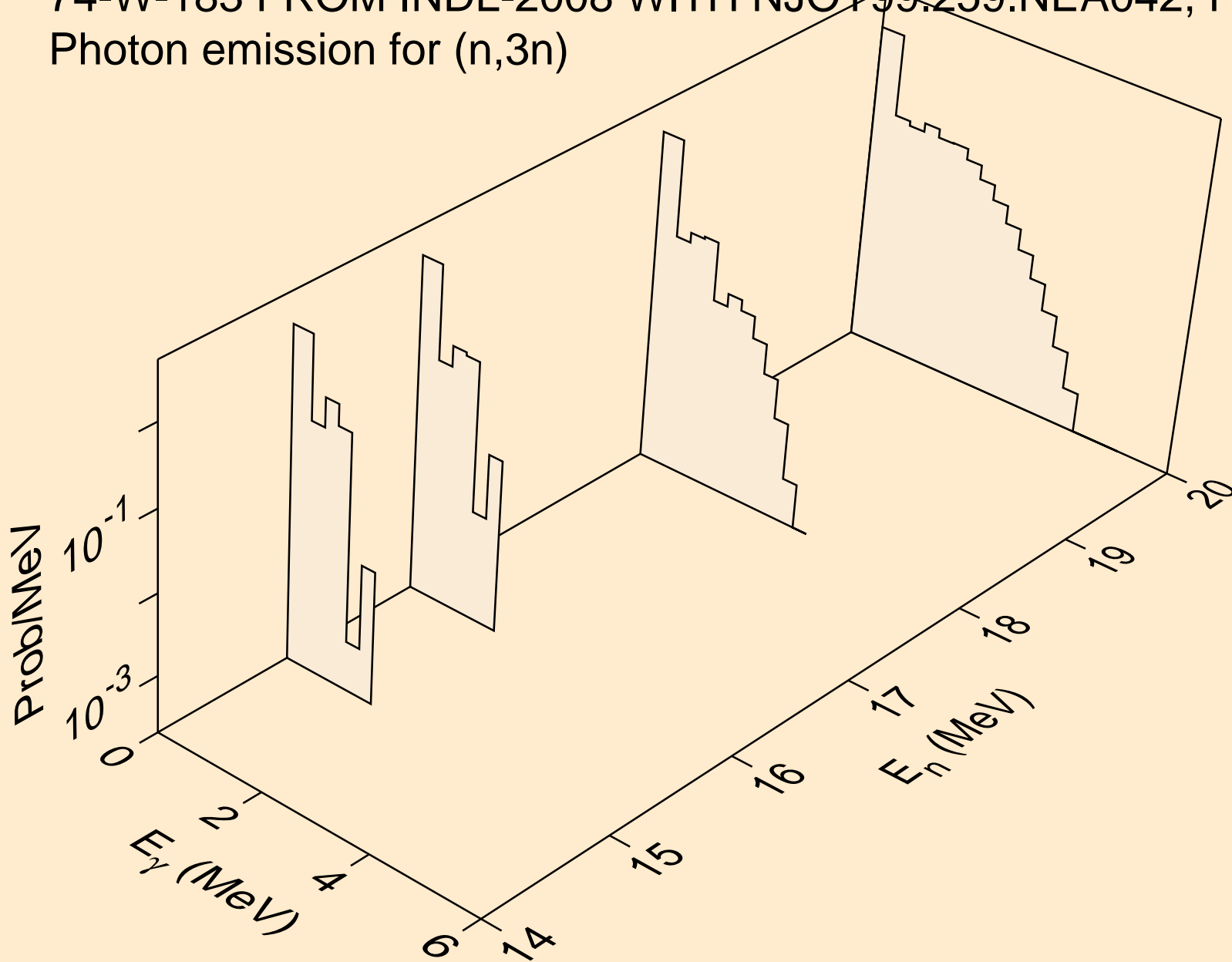

74-W-183 FROM INDL-2008 WITH NJOY99.259.NEA042, FEB. 200
Photon emission for (n,x)

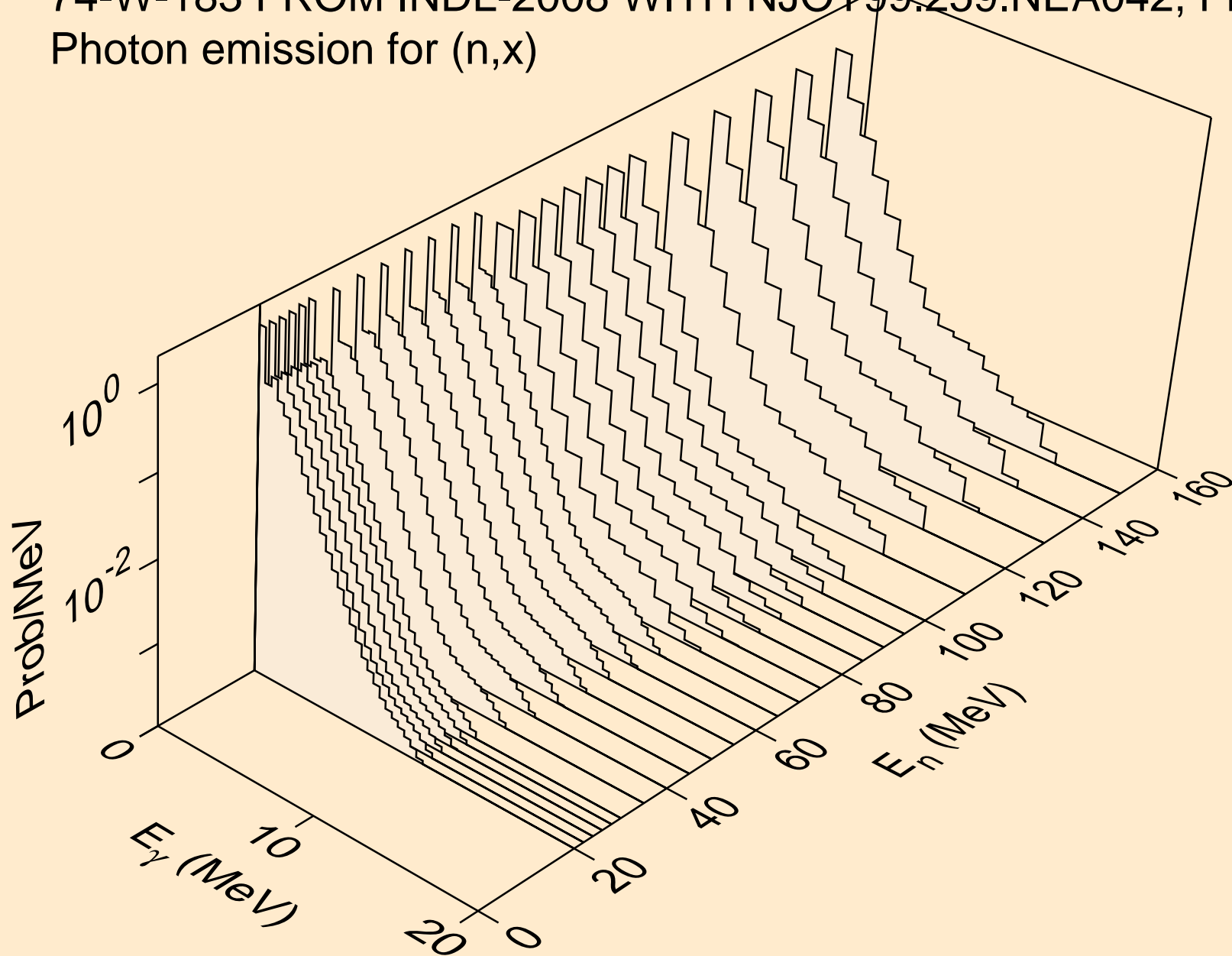

74-W-183 FROM INDL-2008 WITH NJOY99.259.NEA042, FEB. 200
thermal capture photon spectrum

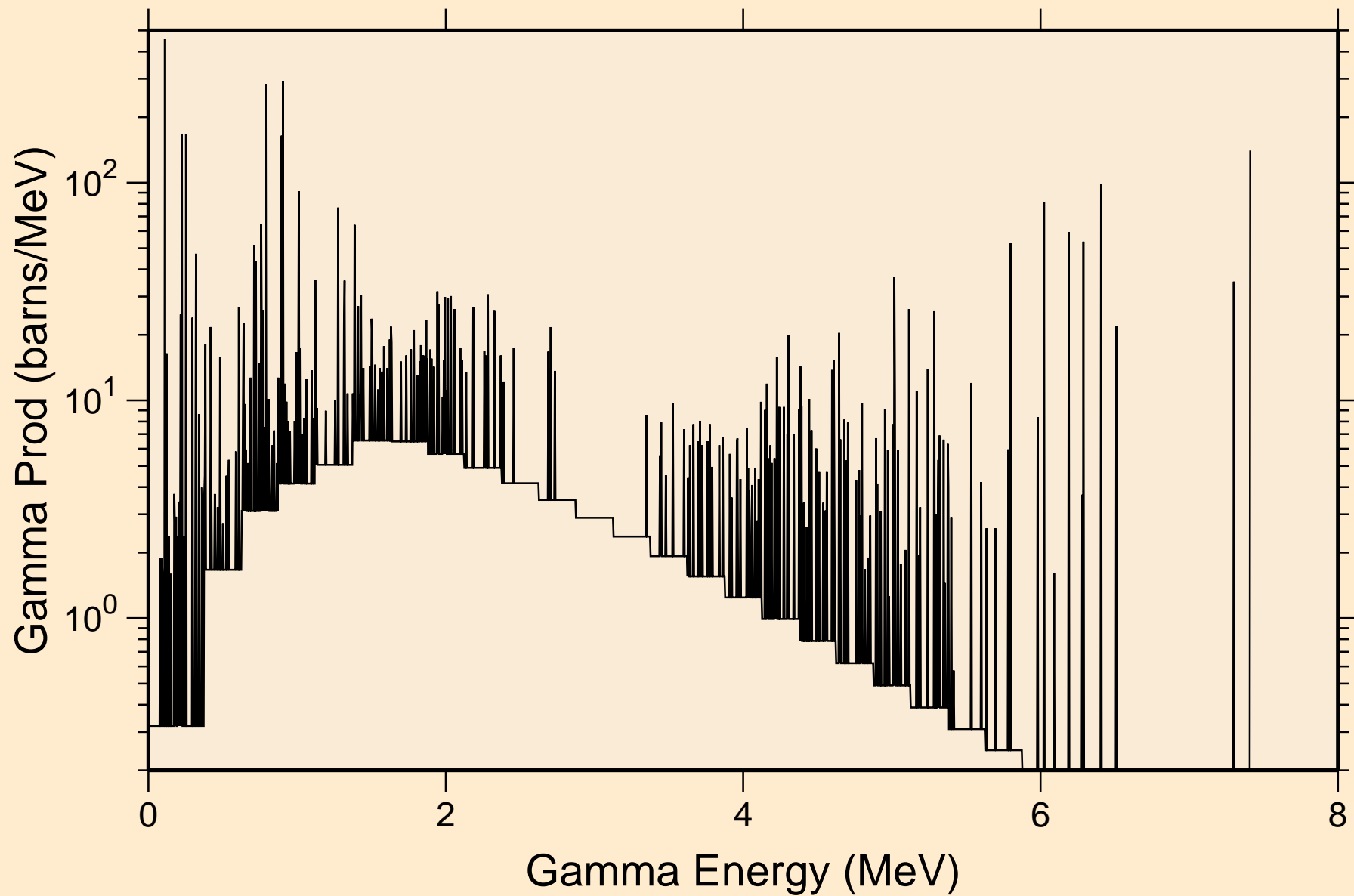

74-W-183 FROM INDL-2008 WITH NJOY99.259.NEA042, FEB. 200
14 MeV photon spectrum

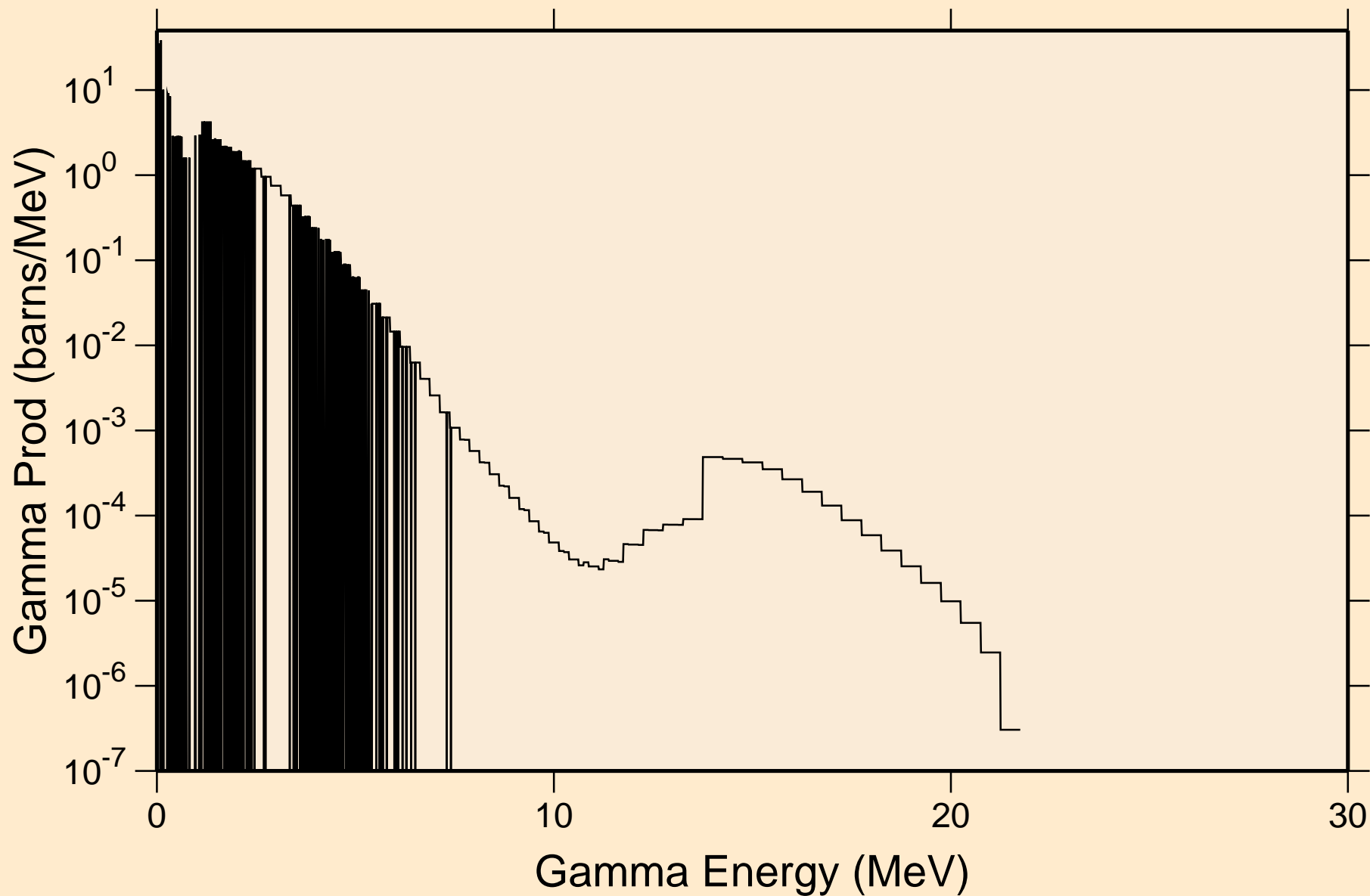

74-W-183 FROM INDL-2008 WITH NJOY99.259.NEA042, FEB. 200
Particle heating contributions

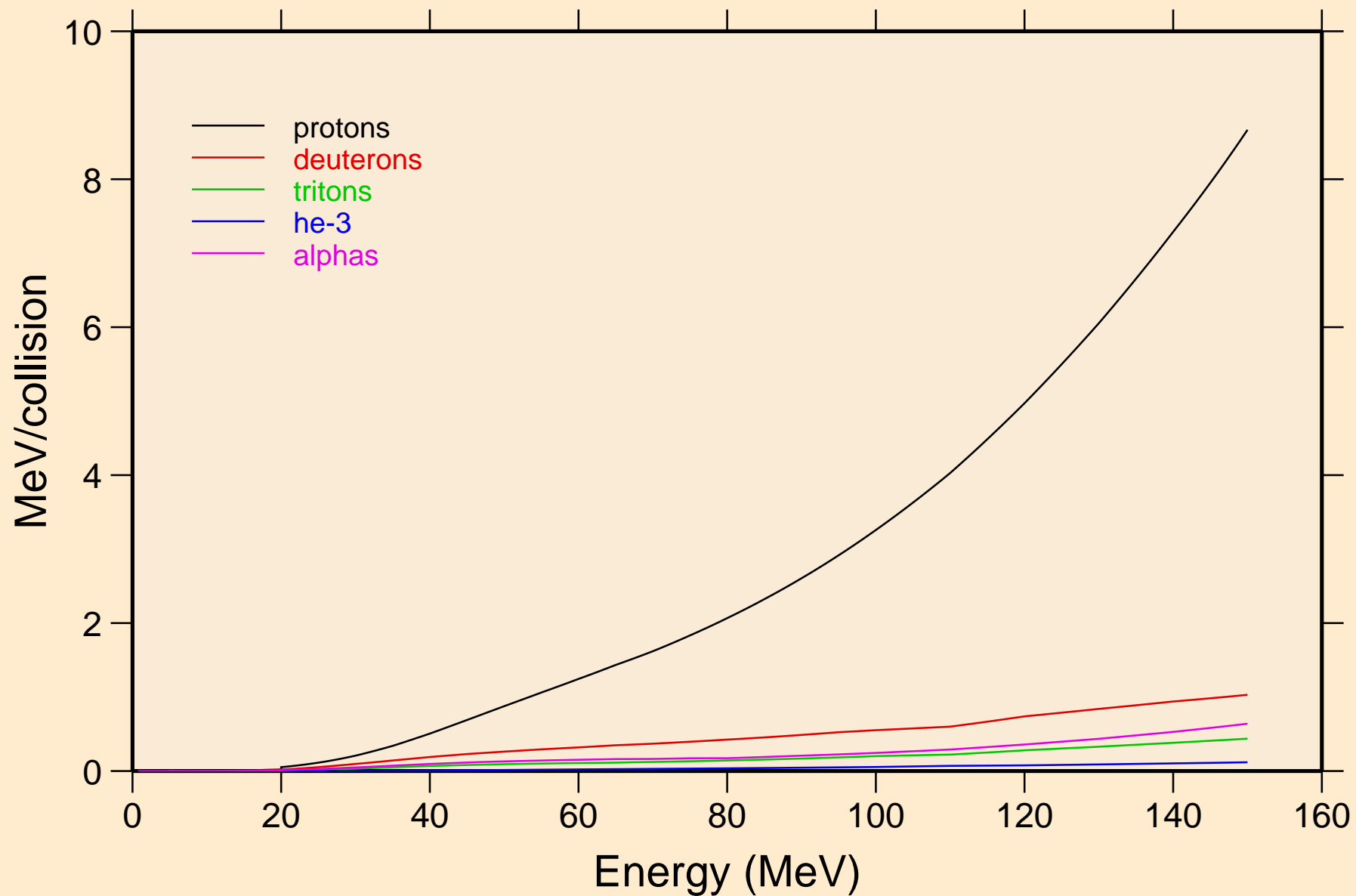

74-W-183 FROM INDL-2008 WITH NJOY99.259.NEA042, FEB. 200
Recoil Heating

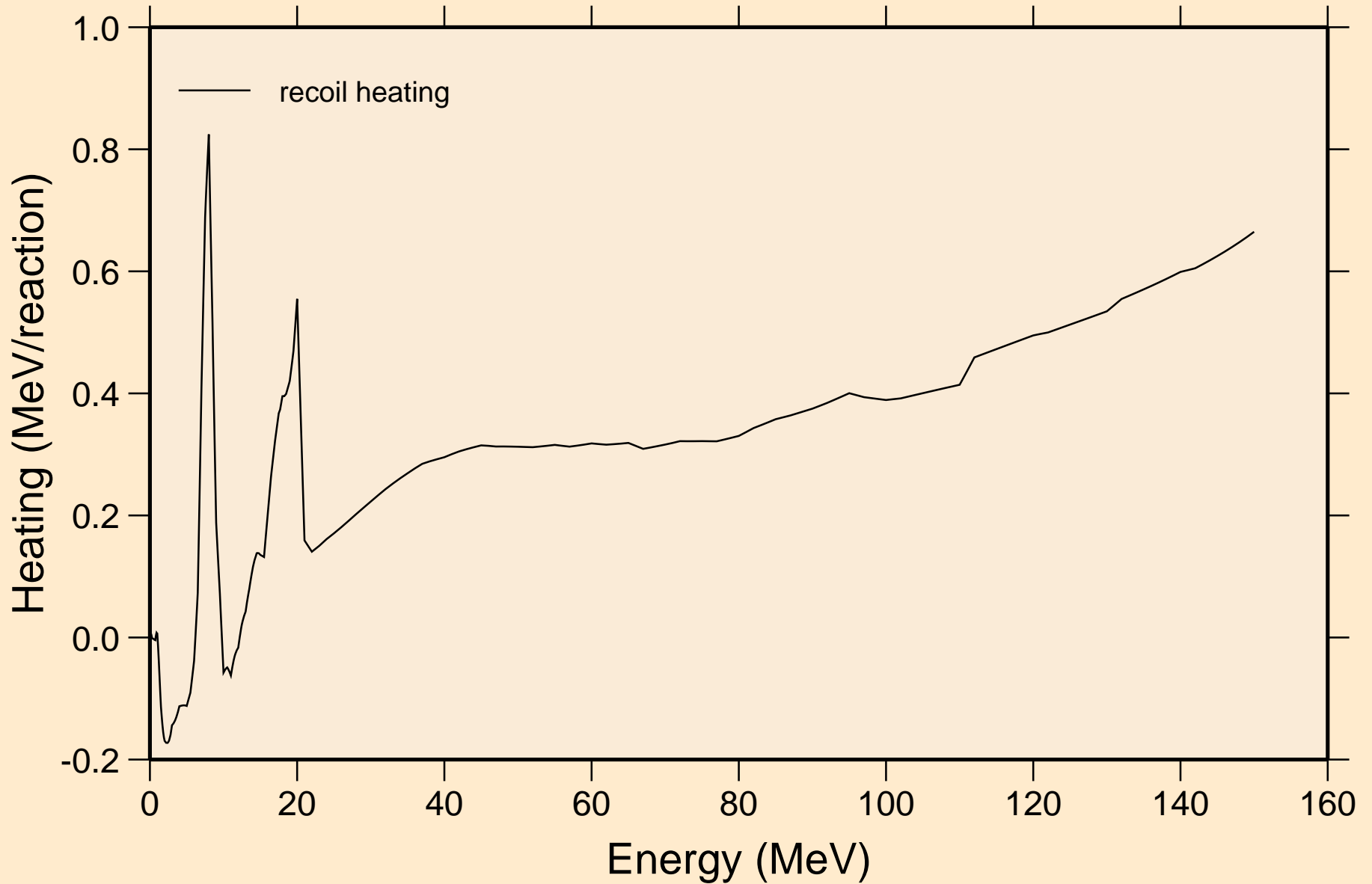

74-W-183 FROM INDL-2008 WITH NJOY99.259.NEA042, FEB. 200
Particle production cross sections

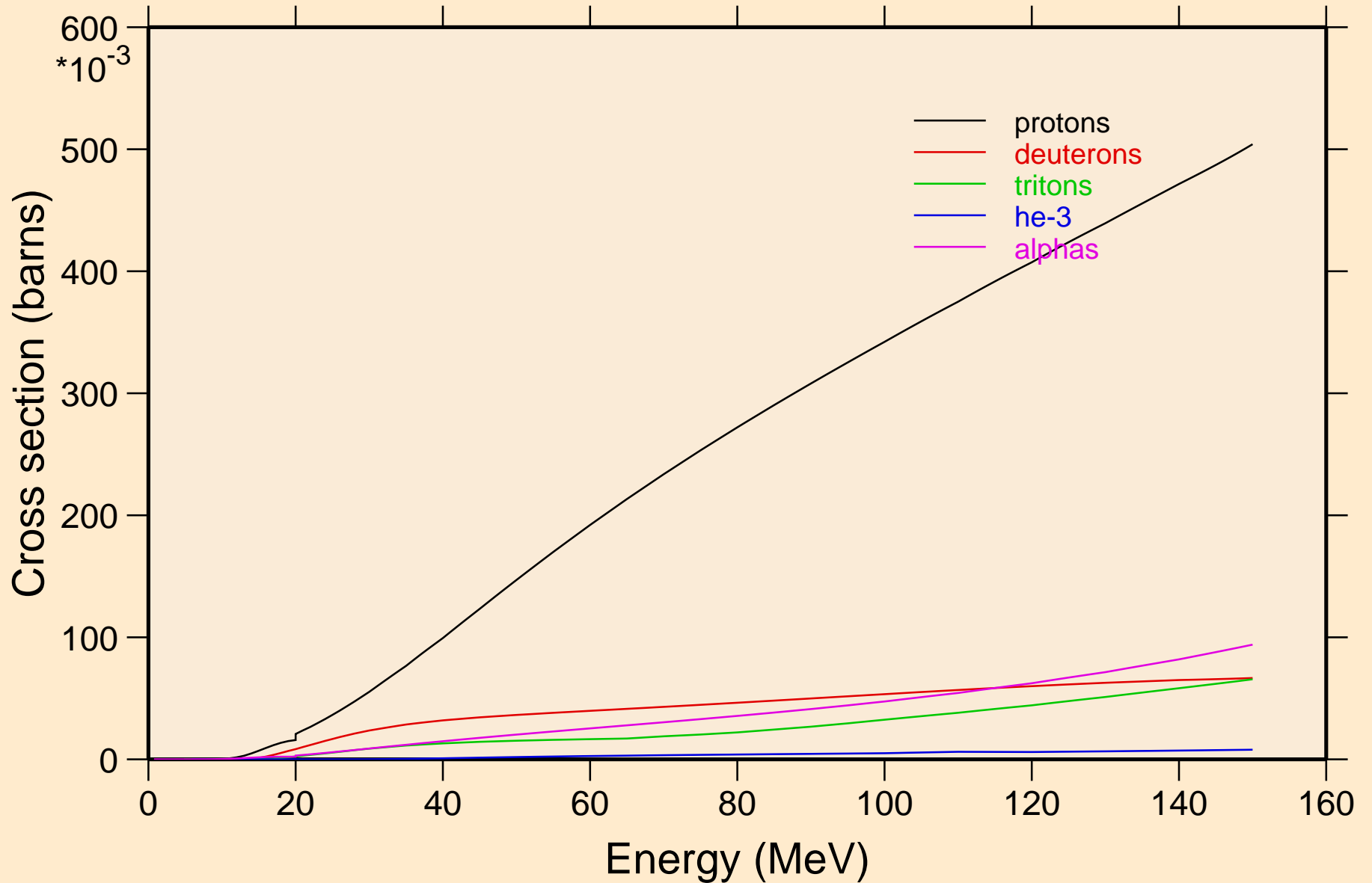

74-W-183 FROM INDL-2008 WITH NJOY99.259.NEA042, FEB. 200
protons from (n,x)

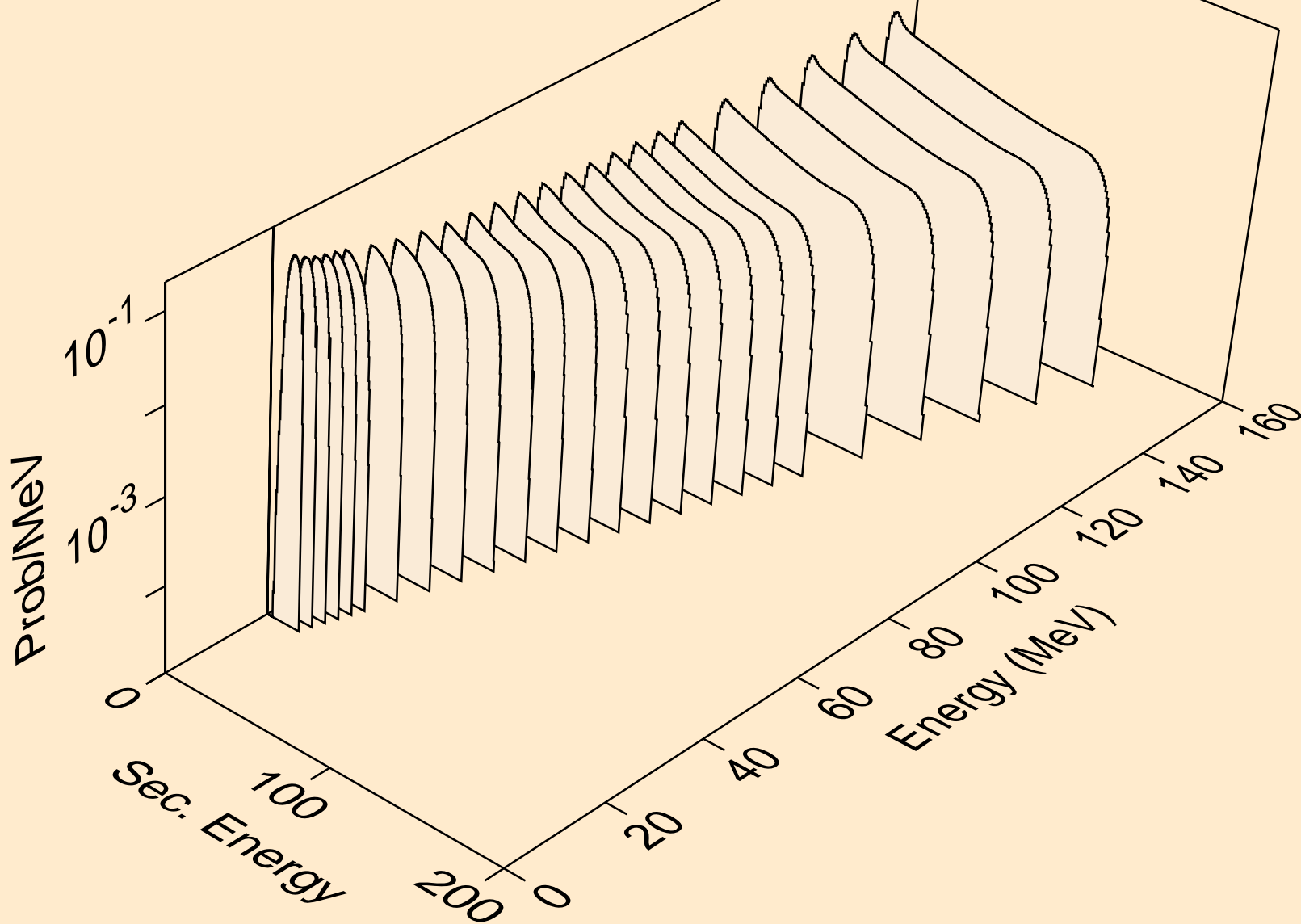

74-W-183 FROM INDL-2008 WITH NJOY99.259.NEA042, FEB. 200
protons from (n,p)

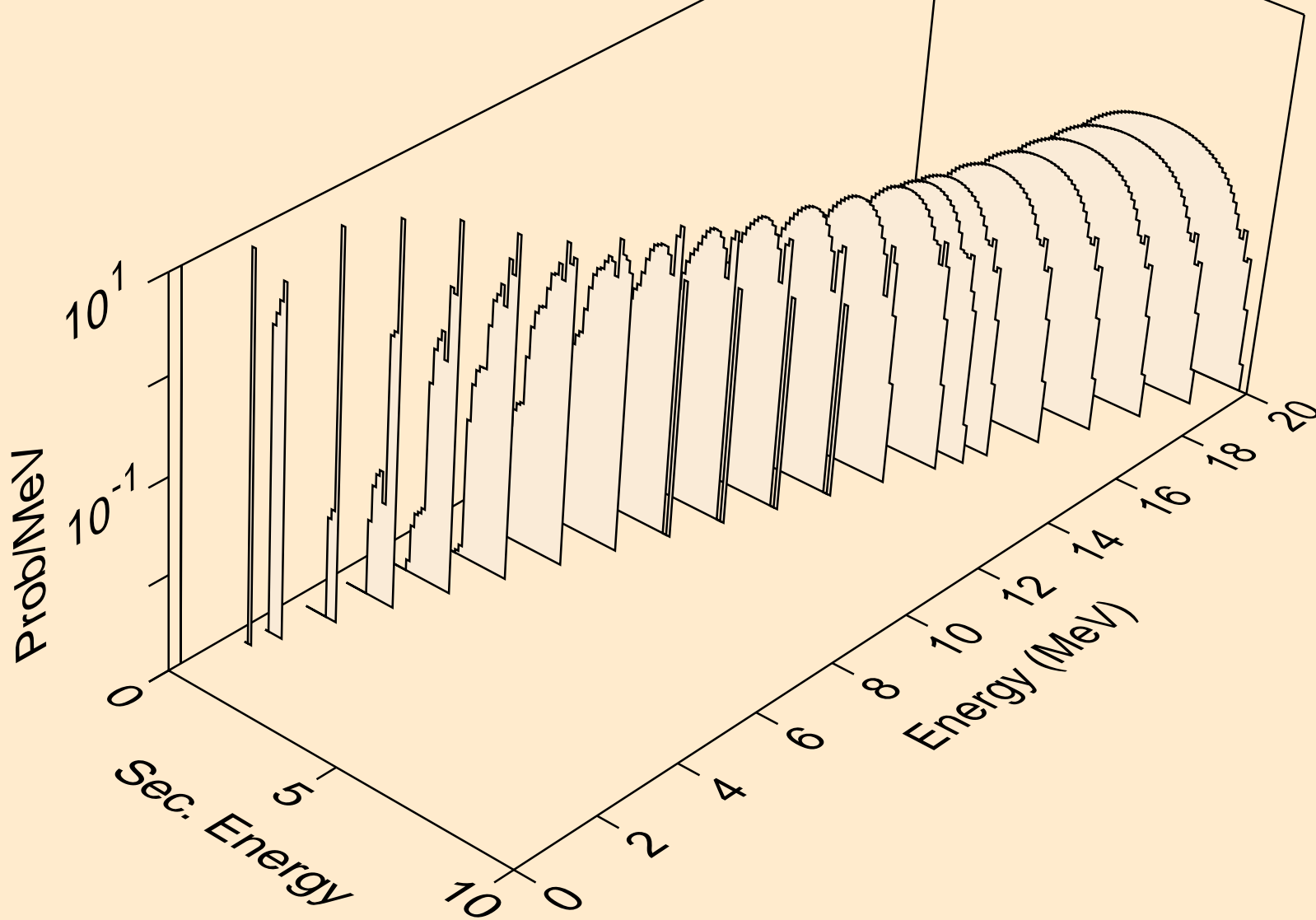

74-W-183 FROM INDL-2008 WITH NJOY99.259.NEA042, FEB. 200
deuterons from (n,x)

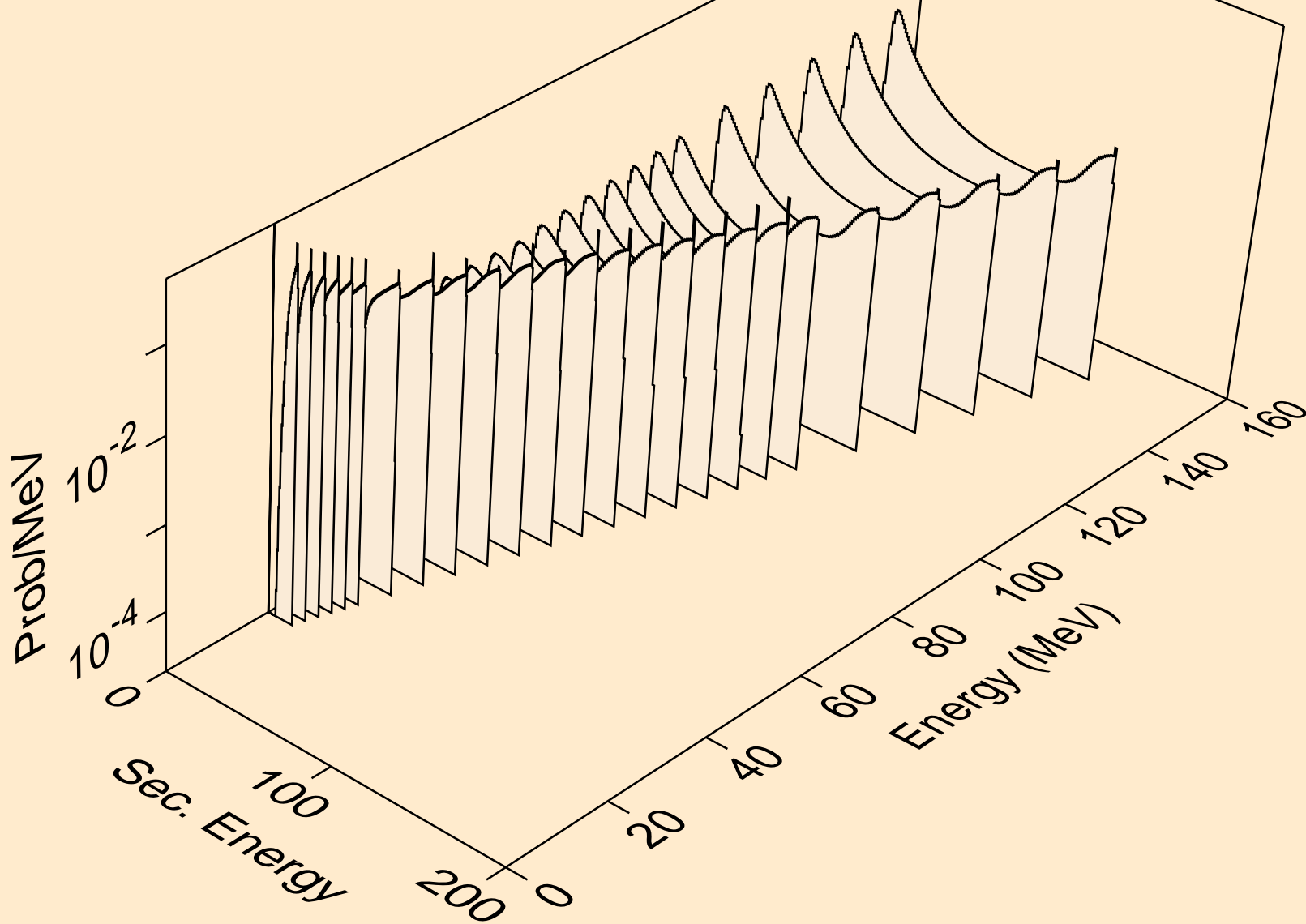

74-W-183 FROM INDL-2008 WITH NJOY99.259.NEA042, FEB. 200
deuterons from (n,d)

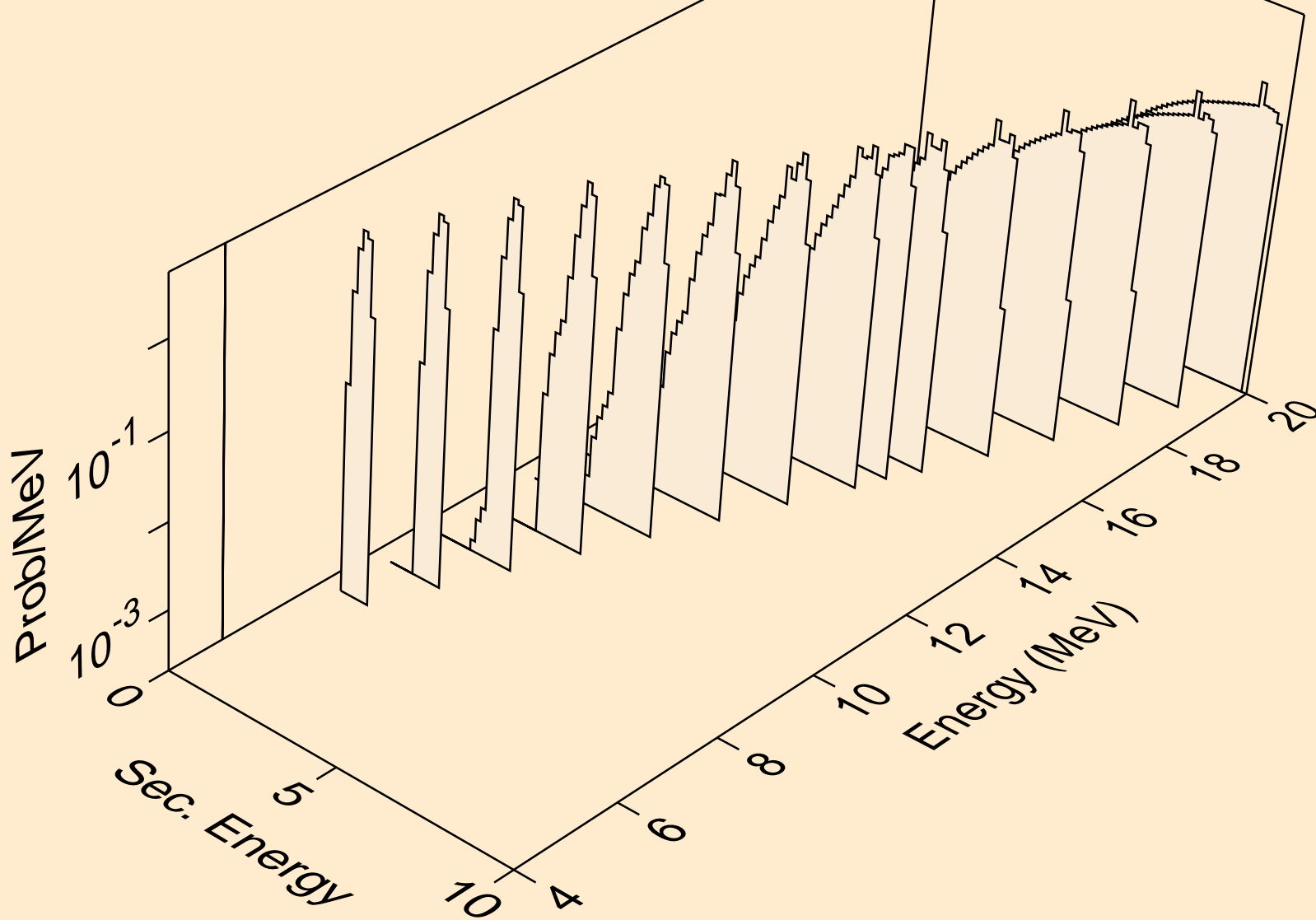

74-W-183 FROM INDL-2008 WITH NJOY99.259.NEA042, FEB. 200
tritons from (n,x)

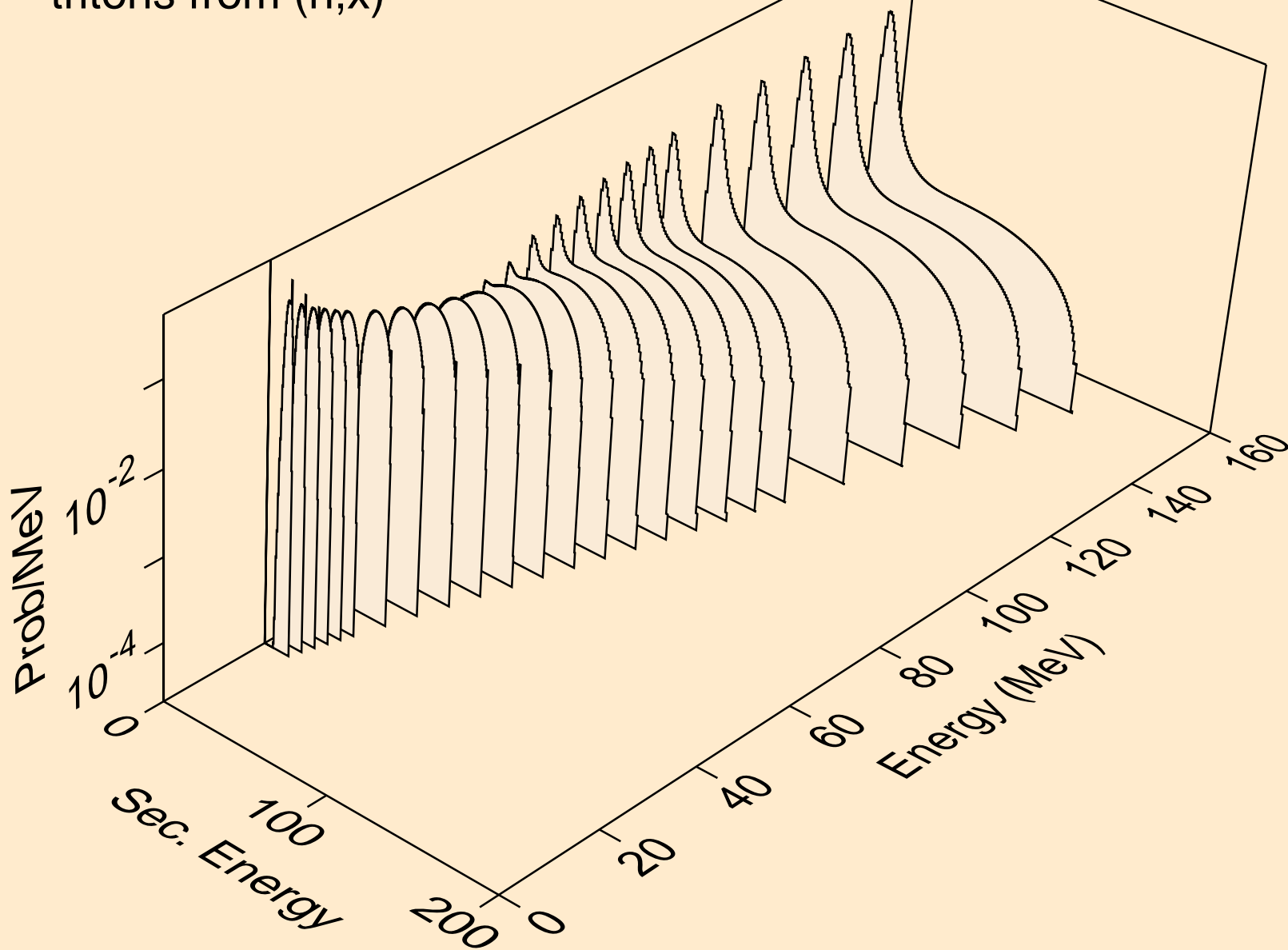

74-W-183 FROM INDL-2008 WITH NJOY99.259.NEA042, FEB. 200
tritons from (n,t)

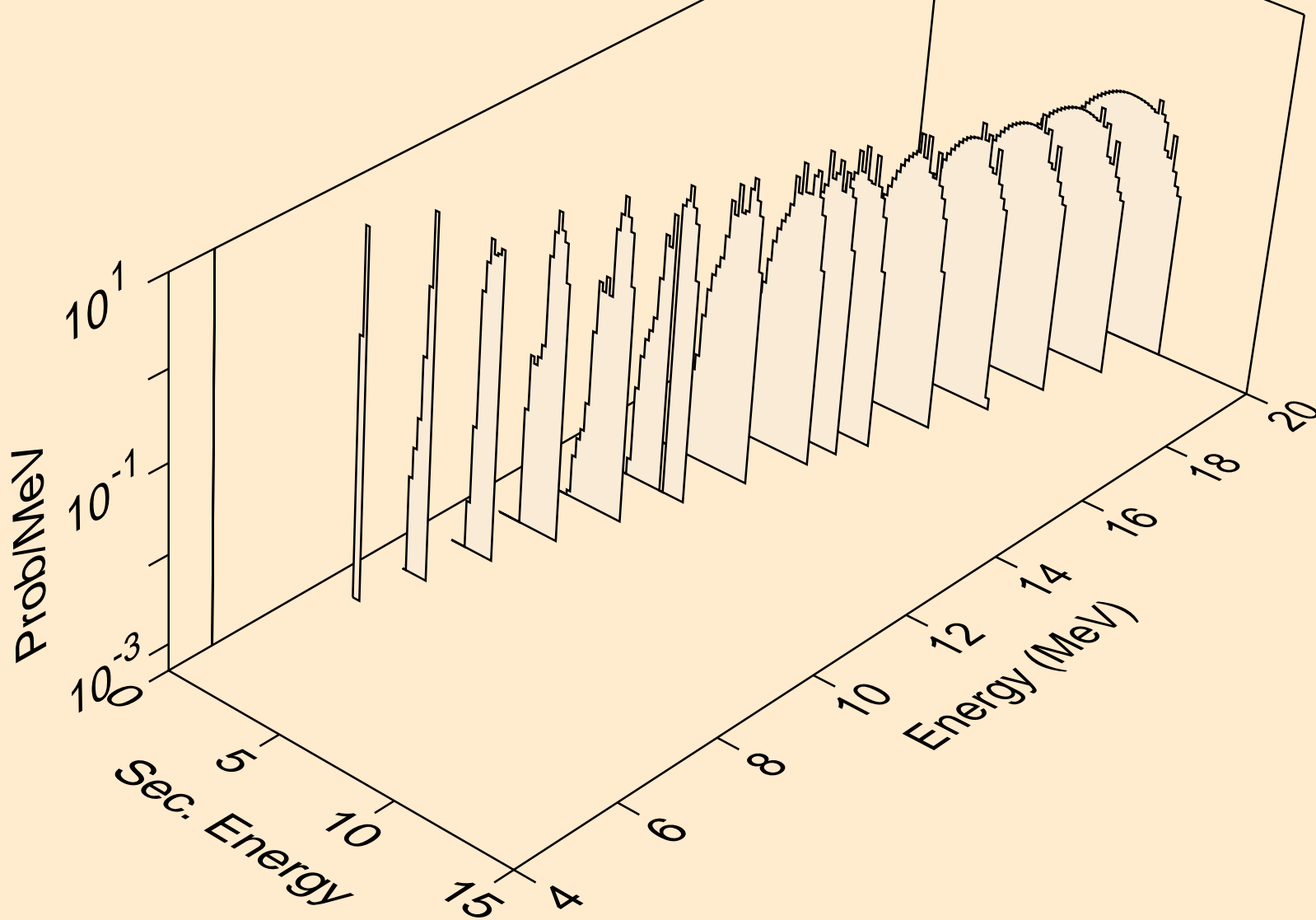

74-W-183 FROM INDL-2008 WITH NJOY99.259.NEA042, FEB. 200
he3s from (n,x)

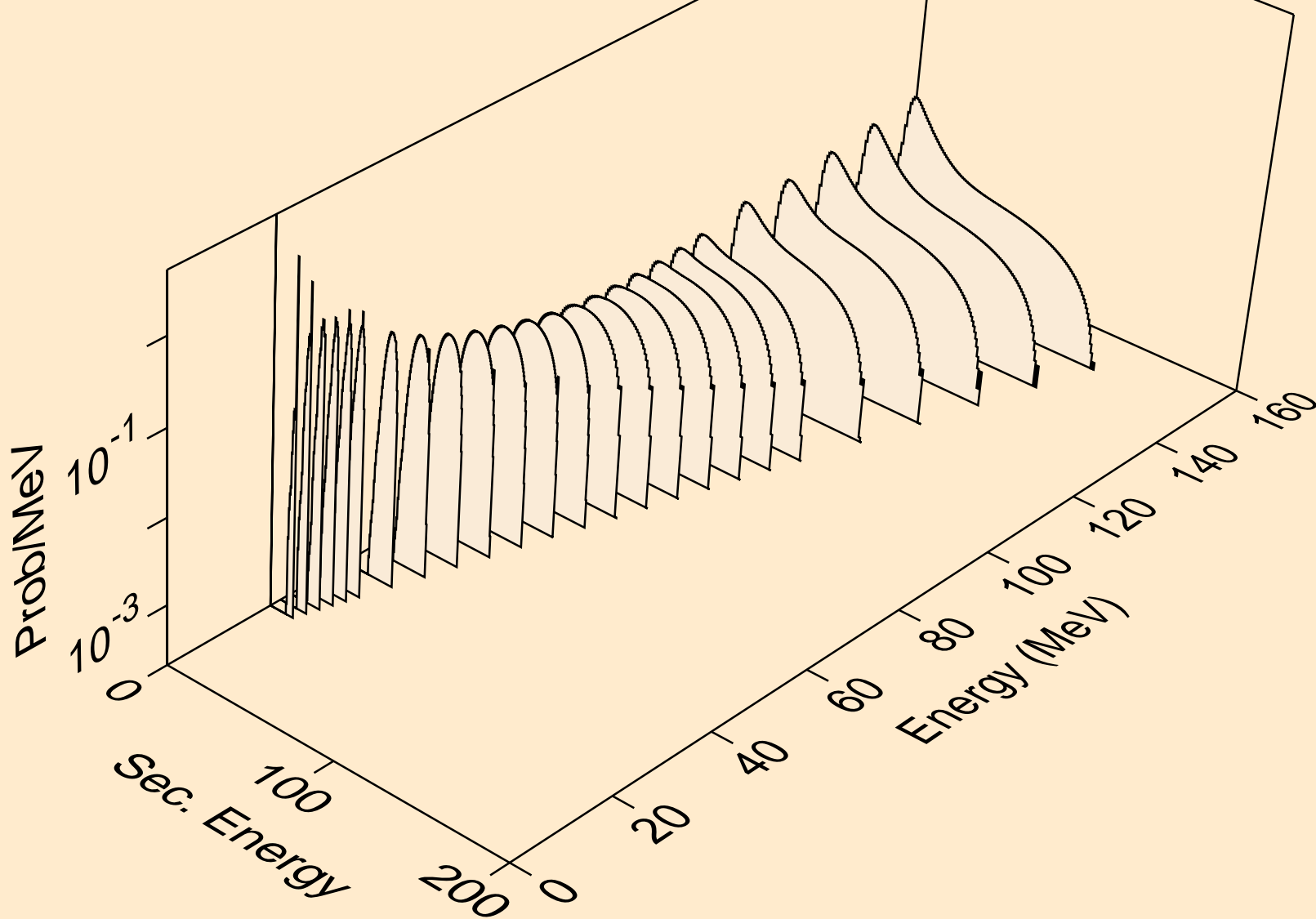

74-W-183 FROM INDL-2008 WITH NJOY99.259.NEA042, FEB. 200
he3s from (n,he3)

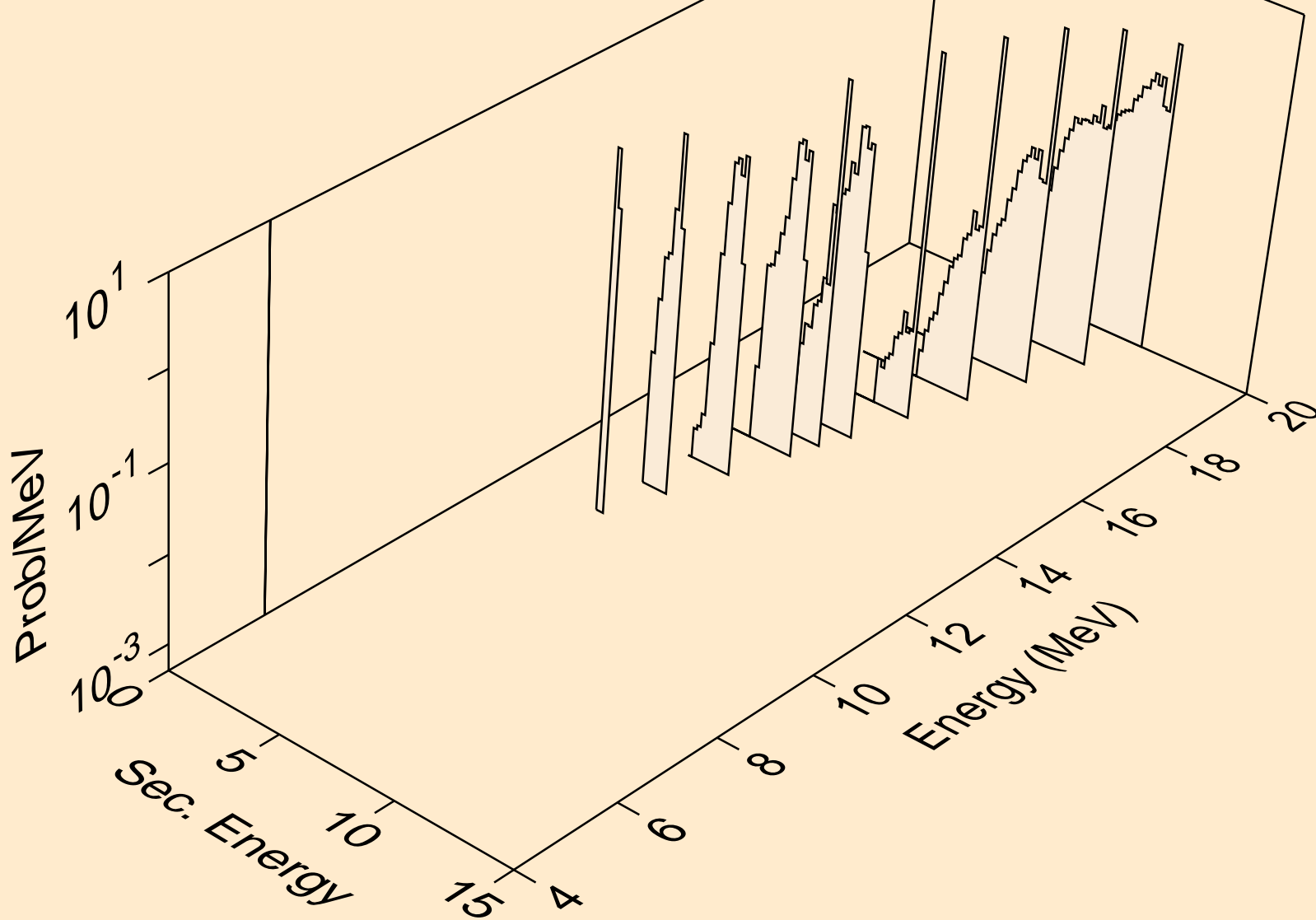

74-W-183 FROM INDL-2008 WITH NJOY99.259.NEA042, FEB. 200
alphas from (n,x)

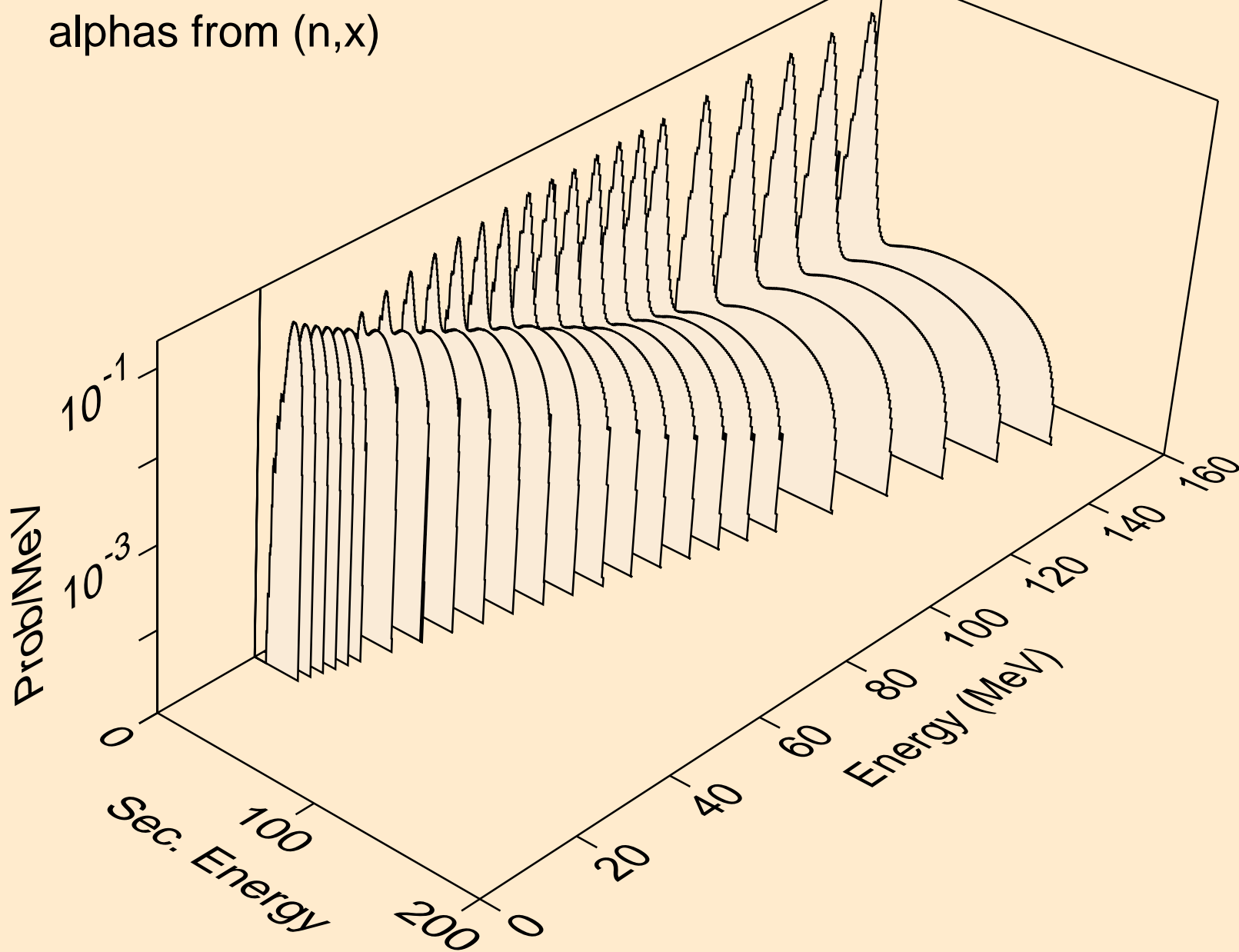

74-W-183 FROM INDL-2008 WITH NJOY99.259.NEA042, FEB. 200
alphas from (n,a)

